

Models and manufacturing numbers in this manual are shown on pages 4 and 5.

Service

Home Laundry Dryers

Service Manual for
Amana®

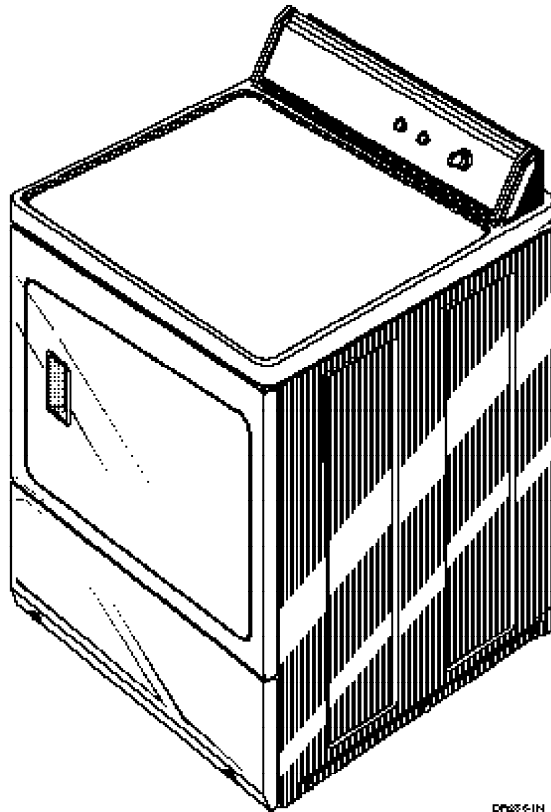

DF226-1IN

This manual is to be used by qualified appliance technicians only. Amana does not assume any responsibility for property damage or personal injury for improper service procedures done by an unqualified person.

Amana
Electric Appliances

RS3200001
Revision 3
(502992R3)
December 1996

a WARNING

Failure to install, maintain, and/or operate this product according to the manufacturer's instructions may result in conditions which can produce serious injury, death and/or property damage.

Do not repair or replace any part of the product or attempt any servicing unless specifically recommended or published in this Service Manual and that you understand and have the skills to carry out.

Whenever ground wires are removed during servicing, these ground wires must be reconnected to ensure that the product is properly grounded and to reduce the risk of fire, electric shock, serious injury, or death.

W006R1

a WARNING

Repairs that are made to your products by unqualified persons can result in hazards due to improper assembly or adjustments subjecting you, or the inexperienced person making such repairs, to the risk of serious injury, electrical shock, or death.

W007

a CAUTION

If you or an unqualified person perform service on your product, you must assume the responsibility for any personal injury or property damage which may result. The manufacturer will not be responsible for any injury or property damage arising from improper service and/or service procedures.

W008

NOTE: The WARNINGS and IMPORTANT INSTRUCTIONS appearing in this manual are not meant to cover all possible conditions and situations that may occur. It must be understood that common sense, caution and carefulness are factors which CANNOT be built into these products. These factors MUST BE supplied by the person(s) installing, maintaining or operating the product.

Always contact your dealer, distributor, service agent or the manufacturer about any problems or conditions you do not understand.

In order to locate an authorized service agency, contact the dealer from whom you purchased this product or:

Consumer Affairs Dept.	or	1-800-628-5782
2800 220 th Trail		CALL and ask for the
P.O. Box 8901		Consumer Affairs Department
Amana, Iowa 52204-0001		

Users of products outside of the United States and Canada should contact:

**INTERNATIONAL DIVISION
AMANA REFRIGERATION, INC.
2800 220th TRAIL
P.O. BOX 8901
AMANA, IOWA 52204-0001, USA
Telephone: (319) 622-5511
Facsimile: (319) 622-2180**

Recognize Safety Symbols, Words and Labels

a DANGER — **Immediate hazards which WILL result in serious injury or death.**

a WARNING — **Hazards or unsafe practices which COULD result in serious injury or death.**

a CAUTION — **Hazards or unsafe practices which COULD result in minor or moderate injury or product or property damage.**

W009

©Copyright 1996, Raytheon Appliances

All rights reserved. No part of the contents of this book may be reproduced or transmitted in any form or by any means without the written permission of the publisher.

Table of Contents

Nameplate Location	4
Model Identification	4

SECTION I — Grounding

1. Motor Mounting Bracket to Motor	6
2. Neutral at Terminal Block to Rear Bulkhead and from Rear Bulkhead to Control housing	7
3. Power Cord to Rear Bulkhead and from Rear Bulkhead to Control Housing. Wall Receptacle Polarity Check	7
4. From Rear Bulkhead to Timer Mounting Bracket to Dryer Cabinet Top. Timer Mounting Bracket to Graphic Panel	8
From Rear Bulkhead to Dryer Cabinet Top to Electronic Control to Graphic Panel.....	8

SECTION II — Service Procedures

5. Control Hood Assembly	9
6. Fluorescent Light Assembly	9
7. Control Hood End Caps	9
8. Graphics Panel	10
9. Timer	10
10. Temperature Switch	10
11. Signal Control	10
12. Printed Circuit Board	10
13. Electronic Control	10
14. Lint Filter	15
15. Inner and Outer Door Panels and Door Pull	16
16. Loading Door	16
17. Door Strike	19
18. Door Seal	19
19. Front Panel and Panel Seal	20
20. Door Switch	20
21. Strike Catch	20
22. Door Hinge	22
23. Hold-Down Clips and Guide Lugs	22
24. Burner System Components	23
25. Burner Housing and Heat Shroud	25
26. Limit Thermostat	25
27. Heating Element	25
28. Thermister or Thermostat and Heater	26
29. Front Air Duct	26

30. Motor and Exhaust Assembly	27
31. Cabinet Top	30
32. Cylinder Light	31
33. Cylinder Light Receptacle	31
34. Front Bulkhead Assembly	32
35. Moisture Sensor	33
36. Cylinder Belt	34
37. Cylinder Assembly	35
38. Rear Seal	36
39. Cylinder Rollers	38
40. Outlet Cover	38
41. Rear Bulkhead and Heater Box	39
42. Terminal Block or Power Cord	41
43. Terminal Block Terminals	43
44. Cabinet	43
45. Base	45

SECTION III — Adjustments

46. Leveling Legs	46
47. Burner Flame	47

SECTION IV — Test Procedures

48. Drive Motor	49
49. Burner System Operation	52
50. Electrical Circuit to Ignition System	53
51. Gas Valve Coils	54
52. Sensor	55
53. Igniter	55
54. Temperature Switch	55
55. Door Switch	56
56. Signal Control	56
57. Timer Contact Points	56
58. Cycling or Limit Thermostat	56
59. Thermostat Heater	58
60. Thermal Fuse	59
61. Heater Assembly	59

SECTION V — Service Helps

62. Motor Does Not Run	60
63. Unit Stops in Cycle; Quits after a Couple Loads; Has a Burning Smell; Cycles on Motor Thermal Protector	61
64. Motor Runs But Cylinder Does Not Turn	61
65. Motor Does Not Stop	62

66. Heating Assembly Does Not Heat or Burner Does Not Ignite	62
67. Igniter Does Not Glow	63
68. Burner Ignites and Goes Out Repeatedly	63
69. Igniter Glows But Burner Does Not Ignite	63
70. Heater Assembly or Burner Shuts Off Prematurely	64
71. Heater Assembly or Burner Repeatedly Cycles Off On Limit Thermostat	64
72. Heater Assembly or Burner Does Not Shut Off	65
73. Clothes Do Not Dry	65
74. Timer Does Not Advance in Automatic Cycle	66
75. Clothes Are Too Hot When Removed From Dryer	66

**SECTION VI — Internal Wiring of Dryer Motor
Switch** 67

**SECTION VII — Service Procedures Unique
to the Electronic Control
Model Dryers**

76. Electrical Service	68
77. Grounding Instructions	74
78. Failure Symptoms	75
79. Blown Fuse or Tripped Circuit Breaker	77
80. Control Will Not Wake Up (No LED's Light) After SELECT CYCLE Pad is Pressed	78
81. Control Wakes Up (When SELECT CYCLE Pad is Pressed (But Motor Does Not Start)	79

82. Heater Does Not Turn On or No Heat	80
83. Improper Drying Temperature or Dry Times	81
84. "oP" Appears in Time Display	83
85. "SH" Appears in Time Display	84
86. Dryer Goes Into Cool-Down in About Five Minutes and Load is Not Dry	85
87. Control Replacement	86
Electronic Control Board Replacement Report	87

**SECTION VIII — Service Procedures Unique to
the Electromechanical Dryers with Moisture
Sensor**

88. Dryer Operation	88
89. Automatic Cycles	88
90. No Heat	88
91. Time Dry	88
92. Control Replacement	89
93. Timer Contact Points	90
94. Temp/Dryness Control Resistance Chart	91
95. Timer Does Not Advance	92
96. Heater Does Not Turn On or No Heat	93
97. Heater Assembly or Burner Shuts Off Prematurely	94
98. Clothes are Too Hot When Removed From Dryer	95

SECTION IX — Wiring Diagrams 96

Nameplate Location

When calling or writing about your dryer, be sure to mention model, manufacturing, and serial numbers. Model, manufacturing and serial numbers are located on a nameplate. Nameplate is in one of the four corners of the door well. The door well is the shaded area shown.

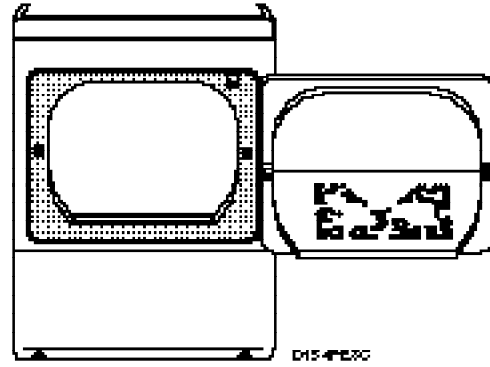

Model Identification

Information in this manual is applicable to these dryer models:

Model Number	Manufacturing Number	Timer Model	Electronic Model	Cylinder	Electric Heat	Gas Heat	Moisture Sensor
CE4317L2	PCE4317L2	X		P.	X		
CE4317W2	PCE4317W2	X		P.	X		
CE8317W2	PCE8317W2	X		P.	X		
CE8407W2	PCE8407W2	X		P.	X		
CE8517W2	PCE8517W2	X		S.S.	X		
CE9207W2	PCE9207W2		X	S.S.	X		X
CG8409W2	PCG8409W2	X		P.		X	
LE4207L2	PLE4207L2	X		P.	X		
LE4217*2	PLE4217*2	X		P.	X		
LE4207W2	PLE4207W2	X		P.	X		
LE4317L2	PLE4317L2	X		P.	X		
LE7101LB	PLE7101LB	X		P.	X		
LE7101WB	PLE7101WB	X		P.	X		
LE7111LB	PLE7111LB	X		P.	X		
LE7111LM	PLE7111LM	X		P.	X		
LE7111WB	PLE7111WB	X		P.	X		
LE7111WM	PLE7111WM	X		P.	X		
LE7121LM	PLE7121LM	X		P.	X		
LE7121WM	PLE7121WM	X		P.	X		
LE7153LB	PLE7153LB	X		S.S.	X		
LE7153LM	PLE7153LM	X		S.S.	X		
LE7153WB	PLE7153WB	X		S.S.	X		
LE7153WM	PLE7153WM	X		S.S.	X		
LE7163LM	PLE7163LM	X		S.S.	X		
LE7163WM	PLE7163WM	X		S.S.	X		
LE8107*2	PLE8107*2	X		U.P.	X		
LE8207*2	PLE8207*2	X		P.	X		
LE8207*3	PLE8207*3	X		P.	X		
LE8217*2	PLE8217*2	X		P.	X		
LE8317L2	PLE8317L2	X		P.	X		
LE8317W2	PLE8317W2	X		P.	X		

P. Painted
S.S. Stainless Steel
U.P. Unpainted

Model Number	Manufacturing Number	Timer Model	Electronic Model	Cylinder	Electric Heat	Gas Heat	Moisture Sensor
LE8407L2	PLE8407L2	X		P.	X		
LE8407W2	PLE8407W2	X		P.	X		
LE8457L2	PLE8457L2	X		P.	X		
LE8457W2	PLE8457W2	X		P.	X		
LE8517L2	PLE8517L2	X		S.S.	X		
LE8517W2	PLE8517W2	X		S.S.	X		
LE8607L2	PLE8607L2	X		S.S.	X		
LE8607W2	PLE8607W2	X		S.S.	X		
LE9207L2	PLE9207L2		X	S.S.	X		
LE9207W2	PLE9207W2		X	S.S.	X		
LG4209L2	PLG4209L2	X		P.		X	
LG4209W2	PLG4209W2	X		P.		X	
LG4219*2	PLG4219*2	X		P.		X	
LG4319L2	PLG4319L2	X		P.		X	
LG4319W2	PLG4319W2	X		P.		X	
LG8101LB	PLG8101LB	X		P.		X	
LG8101WB	PLG8101WB	X		P.		X	
LG8109*2	PLG8109*2	X		U.P.		X	
LG8111LB	PLG8111LB	X		P.		X	
LG8111LM	PLG8111LM	X		P.		X	
LG8111WB	PLG8111WB	X		P.		X	
LG8111WM	PLG8111WM	X		P.		X	
LG8121LM	PLG8121LM	X		P.		X	
LG8121WM	PLG8121WM	X		P.		X	
LG8153LB	PLG8153LB	X		S.S.		X	
LG8153LM	PLG8153LM	X		S.S.		X	
LG8153WB	PLG8153WB	X		S.S.		X	
LG8153WM	PLG8153WM	X		S.S.		X	
LG8163LM	PLG8163LM	X		S.S.		X	
LG8163WM	PLG8163WM	X		S.S.		X	
LG8209*2	PLG8209*2	X		P.		X	
LG8209*3	PLG8209*3	X		P.		X	
LG8219*2	PLG8219*2	X		P.		X	
LG8319L2	PLG8319L2	X		P.		X	
LG8319W2	PLG8319W2	X		P.		X	
LG8409L2	PLG8409L2	X		P.		X	
LG8409W2	PLG8409W2	X		P.		X	
LG8459L2	PLG8459L2	X		P.		X	
LG8459W2	PLG8459W2	X		P.		X	
LG8519L2	PLG8519L2	X		S.S.		X	
LG8519W2	PLG8519W2	X		S.S.		X	
LG8609L2	PLG8609L2	X		S.S.		X	X
LG8609W2	PLG8609W2	X		S.S.		X	X
LG9209L2	PLG9209L2		X	S.S.		X	X
LG9209W2	PLG9209W2		X	S.S.		X	X

P. Painted
S.S. Stainless Steel
U.P. Unpainted

SECTION I

Grounding

WARNING

To reduce the risk of electric shock, fire, explosion, serious injury or death:

- Disconnect electric power to the dryer before servicing.
- Close gas shut-off valve to gas dryer before servicing.
- Never start the dryer with any guards/panels removed.
- Whenever ground wires are removed during servicing, these ground wires must be reconnected to ensure that the dryer is properly grounded.

W001

1. MOTOR MOUNTING BRACKET TO MOTOR (Gas and Electric Models — *Figure 1*).

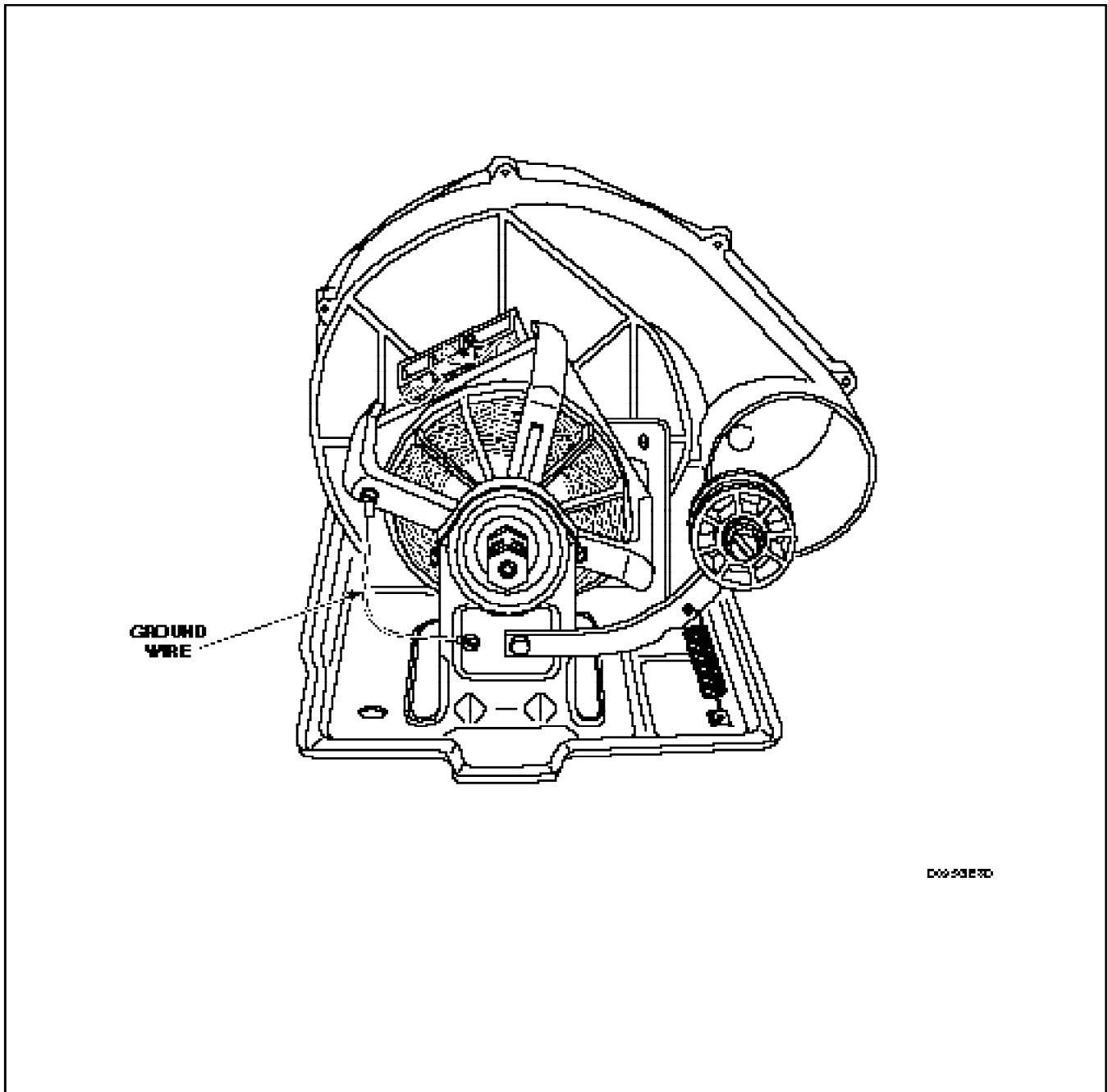

Figure 1

a **WARNING**

To reduce the risk of electric shock, fire, explosion, serious injury or death:

- Disconnect electric power to the dryer before servicing.
- Close gas shut-off valve to gas dryer before servicing.
- Never start the dryer with any guards/panels removed.
- Whenever ground wires are removed during servicing, these ground wires must be reconnected to ensure that the dryer is properly grounded.

W001

2. **NEUTRAL AT TERMINAL BLOCK TO REAR BULKHEAD AND FROM REAR BULKHEAD TO CONTROL HOUSING (Electric Models Only — Figure 2).**

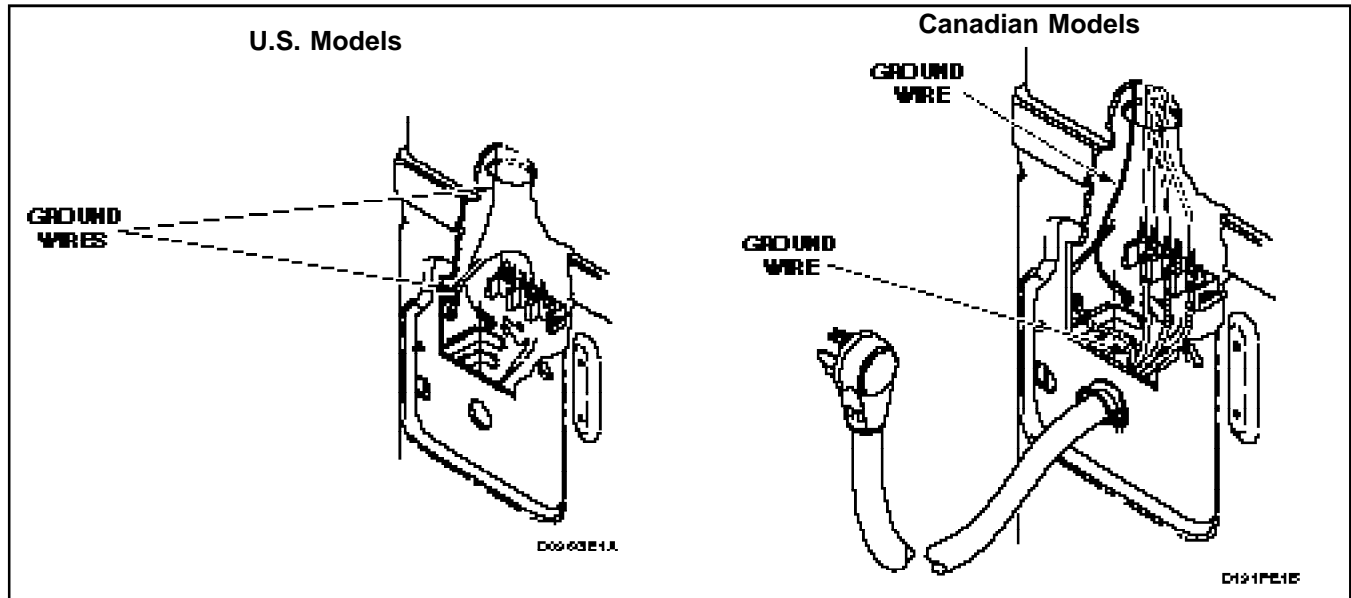

Figure 2

3. **POWER CORD TO REAR BULKHEAD AND FROM REAR BULKHEAD TO CONTROL HOUSING. WALL RECEPTACLE POLARITY CHECK (Gas Models Only — Figure 3).**

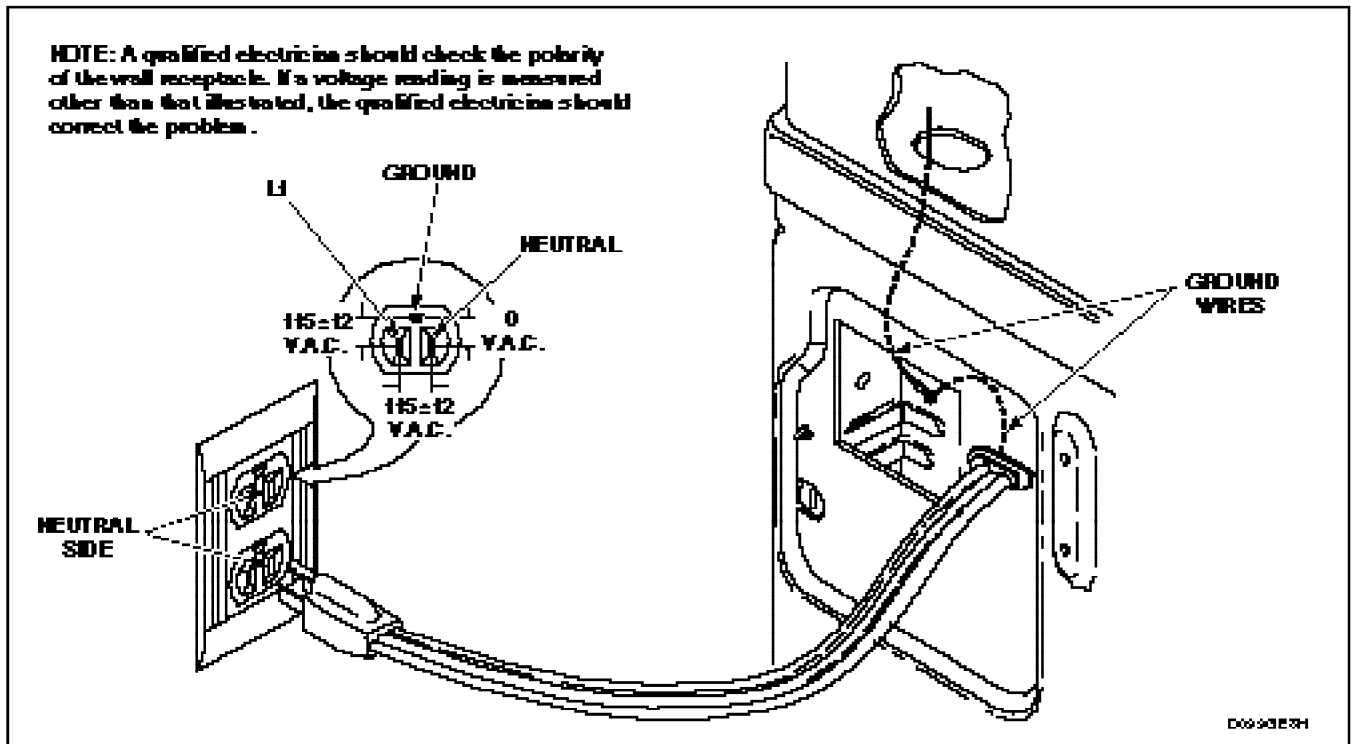

Figure 3

a WARNING

To reduce the risk of electric shock, fire, explosion, serious injury or death:

- Disconnect electric power to the dryer before servicing.
- Close gas shut-off valve to gas dryer before servicing.
- Never start the dryer with any guards/panels removed.
- Whenever ground wires are removed during servicing, these ground wires must be reconnected to ensure that the dryer is properly grounded.

W001

4. FROM REAR BULKHEAD TO TIMER MOUNTING BRACKET TO DRYER CABINET TOP. TIMER MOUNTING BRACKET TO GRAPHIC PANEL (Mechanical Timer Model Dryers — *Figure 4*).

FROM REAR BULKHEAD TO DRYER CABINET TOP TO ELECTRONIC CONTROL TO GRAPHICS PANEL (Electronic Control Model Dryers — *Figure 4*).

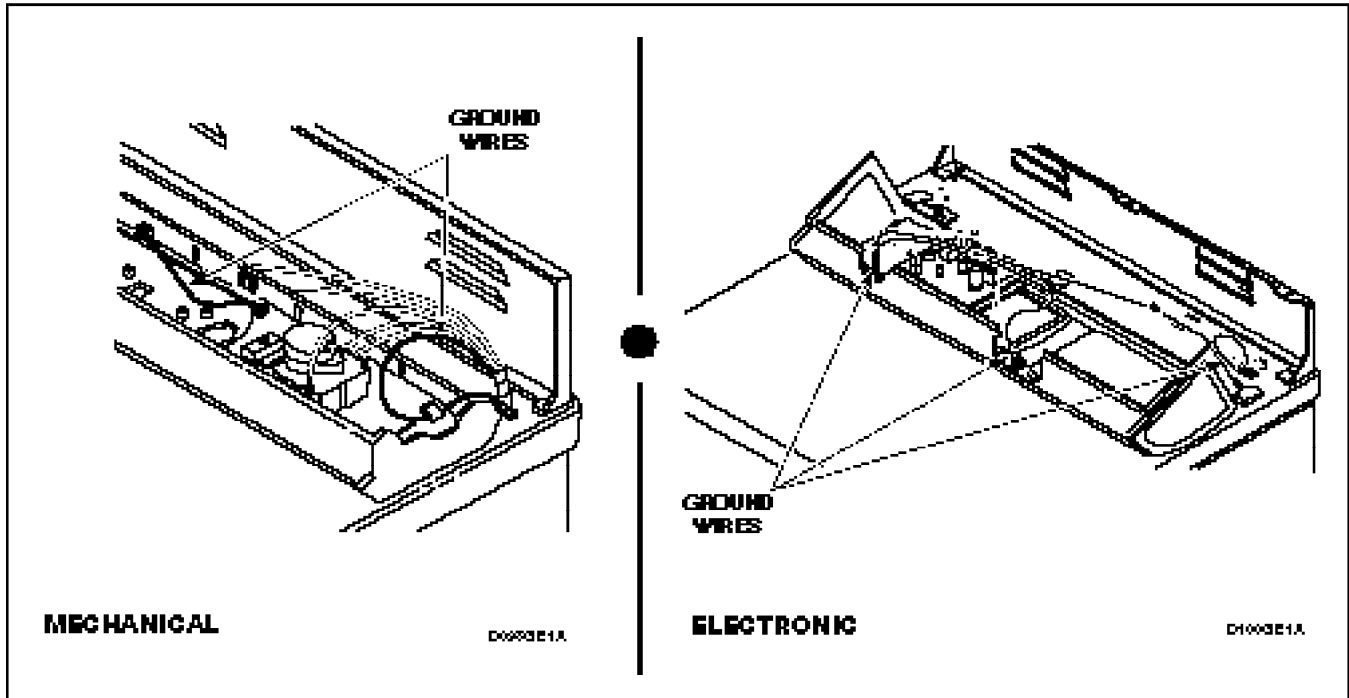

Figure 4

SECTION II

Service Procedures

a WARNING

To reduce the risk of electric shock, fire, explosion, serious injury or death:

- Disconnect electric power to the dryer before servicing.
- Close gas shut-off valve to gas dryer before servicing.
- Never start the dryer with any guards/panels removed.
- Whenever ground wires are removed during servicing, these ground wires must be reconnected to ensure that the dryer is properly grounded.

W001

IMPORTANT: When reference to direction (right or left) is made in this manual, it is from the operator's position facing the front of the dryer.

5. CONTROL HOOD ASSEMBLY

(Figures 5, 6, 7 and 8)

- Remove three screws holding control hood assembly to control hood rear panel.
- Rotate assembly forward to access inner wiring.
- Disconnect wiring from inner components and carefully remove components from control hood assembly.

NOTE: Refer to appropriate wiring diagram when rewiring component parts.

- Rotate control hood assembly forward and lift to free assembly from hold-down clips.

6. FLUORESCENT LIGHT ASSEMBLY (Models containing fluorescent light only)

(Figures 6 and 7)

- Remove three screws holding top cover to control mounting plate. Rotate top cover forward to release front edge of top cover from top edge of diffuser, *Figures 5, 6, 7 and 8*.
- Disconnect two wires from rocker switch (located in diffuser).
- Disconnect wires at disconnect blocks located in control mounting plate.
- Remove two screws holding fluorescent light to control mounting plate.
- Lift fluorescent light out of control mounting plate.

7. CONTROL HOOD END CAPS

(Figures 5, 6, 7 and 8)

- Remove three screws holding control hood assembly to control hood rear panel.
- Rotate assembly forward to access inner wiring.
- Disconnect wiring from inner components and carefully remove components from control hood assembly.

NOTE: Refer to appropriate wiring diagram when rewiring component parts.

- Remove two screws holding end cap to end of mounting plate.
- Carefully pry end cap from control mounting plate and control panel.

NOTE: To re-assemble reverse the steps.

a WARNING

To reduce the risk of electric shock, fire, explosion, serious injury or death:

- Disconnect electric power to the dryer before servicing.
- Close gas shut-off valve to gas dryer before servicing.
- Never start the dryer with any guards/panels removed.
- Whenever ground wires are removed during servicing, these ground wires must be reconnected to ensure that the dryer is properly grounded.

W001

8. GRAPHICS PANEL

(Figures 5, 6, 7 and 8)

- Remove three screws holding control hood assembly to control hood rear panel.
- Rotate assembly forward to access inner wiring.
- Disconnect wiring from inner components and carefully remove components from control hood assembly.

NOTE: Refer to appropriate wiring diagram when rewiring component parts.

- Remove three screws holding top cover to mounting plate. Rotate top cover forward to release front edge of top cover from top edge of diffuser, *Figure 5, 6, 7 and 8*.
- Carefully remove two control knobs and timer knob by pulling forward.
- Remove screws holding end caps to mounting plate and pry caps off mounting plate.
- With graphics panel facing forward, rotate control hood assembly forward to access tabs holding graphics panel.
- Bend graphics panel tabs until straight and pull panel away from control mounting plate.

NOTE: To re-assemble reverse the steps.

9. TIMER

(Figures 5, 6 and 8)

- Remove the three screws holding the control assembly to the control hood rear panel, *Figures 5, 6 and 8*.
- Rotate assembly forward to access inner wiring.
- Disconnect wiring from inner components and carefully remove components from control hood assembly.

NOTE: Refer to appropriate wiring diagram when rewiring component parts.

- Remove two screws holding timer to mounting plate.
- Remove knobs.

10. TEMPERATURE SWITCH

(Not included in electronic control models)

(Refer to *Figures 5, 6 and 8*)

- Remove three screws holding control hood assembly to control hood rear panel.
- Rotate assembly forward to access inner wiring.

- Disconnect wiring from inner components and carefully remove components from control hood assembly.

NOTE: Refer to appropriate wiring diagram when rewiring component parts.

- Remove nut holding temperature switch to control mounting plate.
- Remove two screws holding temperature switch bracket (if separate from temperature switch) to control mounting plate.
- Using a needle nose pliers, press in on locking tabs holding temperature switch to control mounting plate.
- With locking tabs pressed in, rotate temperature switch counterclockwise 1/4 turn and remove switch out rear of control mounting plate.

11. SIGNAL CONTROL

(Figures 5, 6 and 8)

- Remove three screws holding control hood assembly to control hood rear panel.
- Rotate assembly forward to access inner wiring.
- Disconnect wires to the signal control.

NOTE: Refer to appropriate wiring diagram when rewiring component parts.

- Remove signal control knob.
- Remove two screws holding the signal control to the control mounting plate.

12. PRINTED CIRCUIT BOARD

(Models with Moisture Sensor Only)

- Remove three screws holding control hood assembly to control hood rear panel.
- Rotate assembly forward to access inner wiring.
- Pull printed circuit board forward to slide off plastic support pegs.

13. ELECTRONIC CONTROL

(Figure 7)

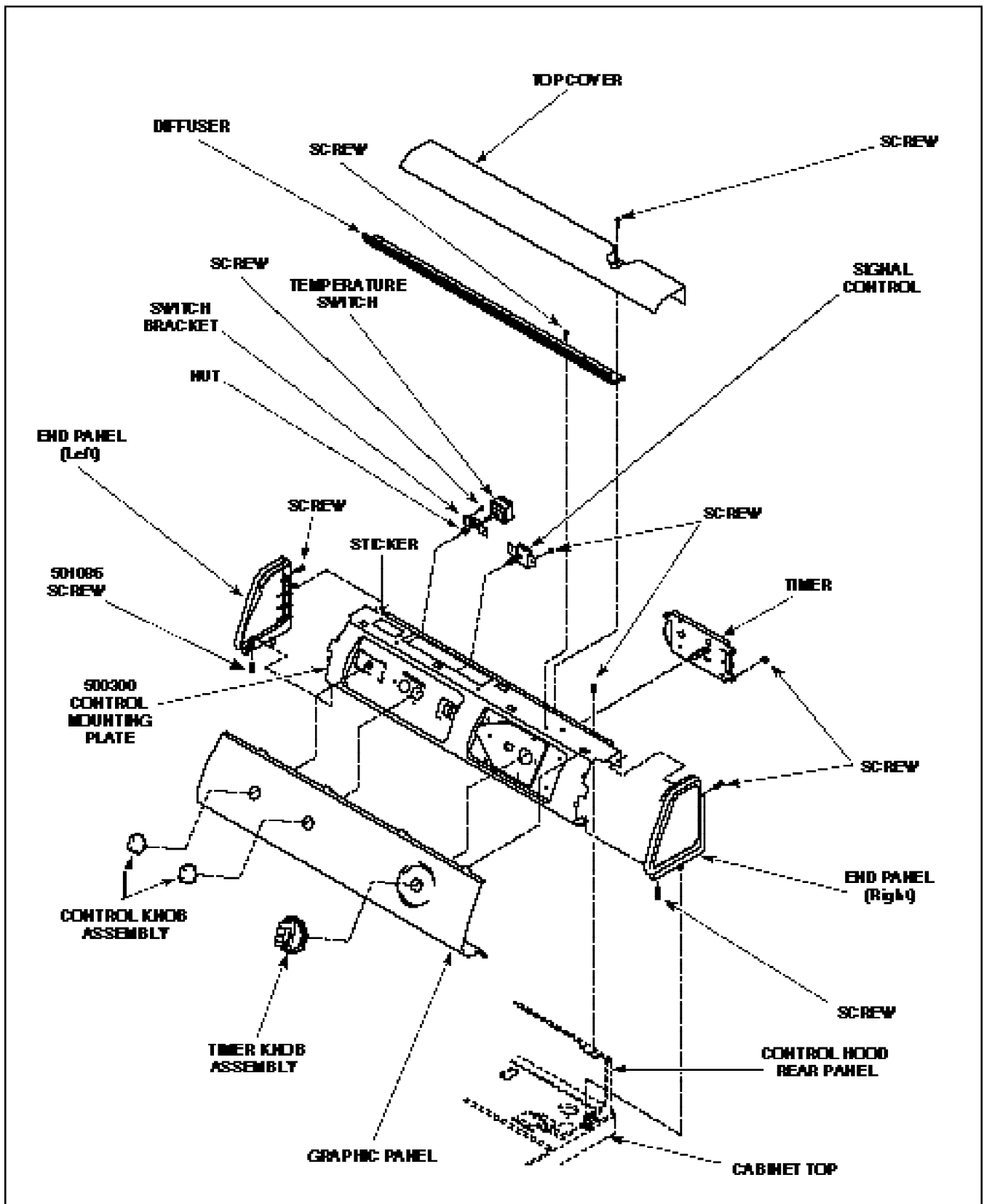

GRAPHIC PANEL, CONTROL HOOD AND CONTROLS
 (Models LE7111*M, LG8111*M, LE8317*2, LG8319*2, LE4317*2, LE8407*2, LE8567*2,
 LE8517*2, LG4319*2, LG8409*2, LG8459*2, LG8569*2, LG8519*2, CE4317*2,
 CE8407*2, CE8517*2, CG8409*2, LE7111*B, LG8111*B and LE8457*2)
 * Is for the color designator, "L" indicates ALMOND and "W" indicates WHITE color.

DISPERSO

Figure 5

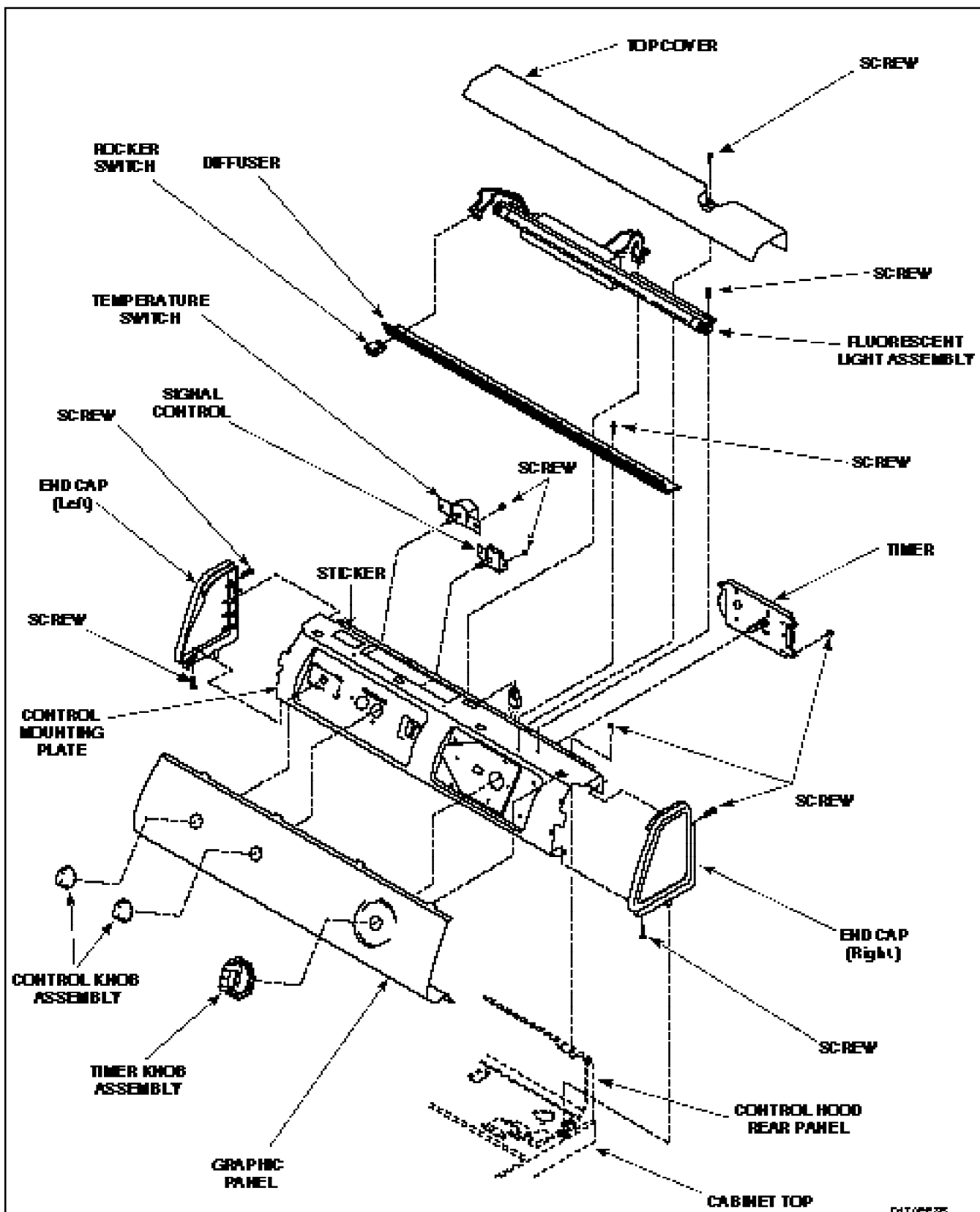

D17/0235

**GRAPHIC PANEL, CONTROL HOOD AND CONTROLS
(Models LE7163*M and LG8163*M)**

* Is for the color designator, "L" indicates ALMOND and "W" indicates WHITE color.

Figure 6

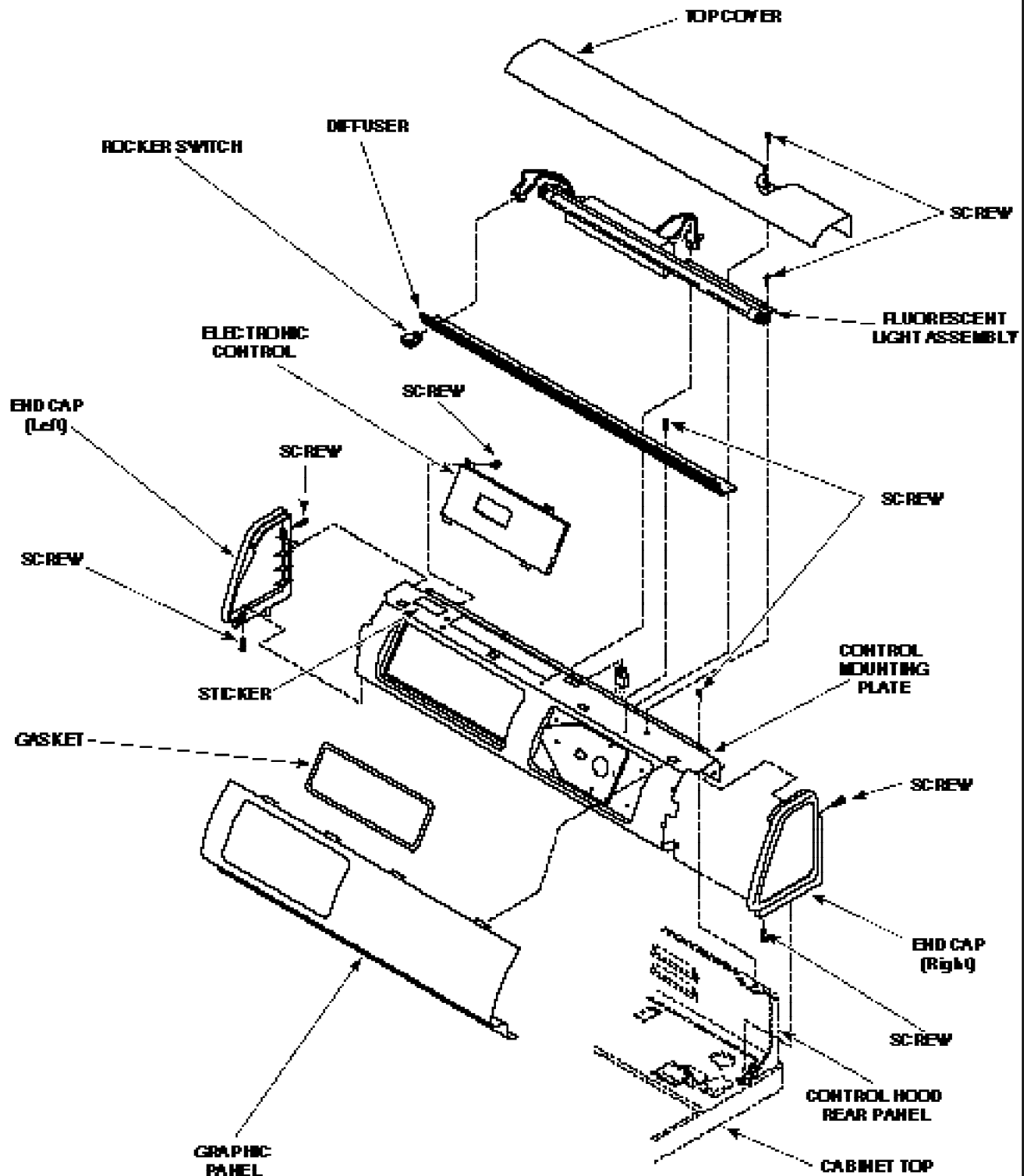

D161PE35

GRAPHIC PANEL, CONTROL HOOD AND CONTROLS
 (Models LE9207*2, LG9209*2 and CE9207*2)

* Is for the color designator, "L" indicates ALMOND and "W" indicates WHITE color.

Figure 7

a WARNING

To reduce the risk of electric shock, fire, explosion, serious injury or death:

- Disconnect electric power to the dryer before servicing.
- Close gas shut-off valve to gas dryer before servicing.
- Never start the dryer with any guards/panels removed.
- Whenever ground wires are removed during servicing, these ground wires must be reconnected to ensure that the dryer is properly grounded.

W001

14. LINT FILTER (Figure 9)

- Open loading door.
- Remove lint filter screws.
- Lift lint filter cover out of lint filter.
- Lift lint filter out of air duct.

a WARNING

When installing lint filter, be sure to install the filter with the word "FRONT" facing the front of the dryer. If filter is installed backwards, lint will accumulate in exhaust system, increasing the risk of fire and machine malfunction.

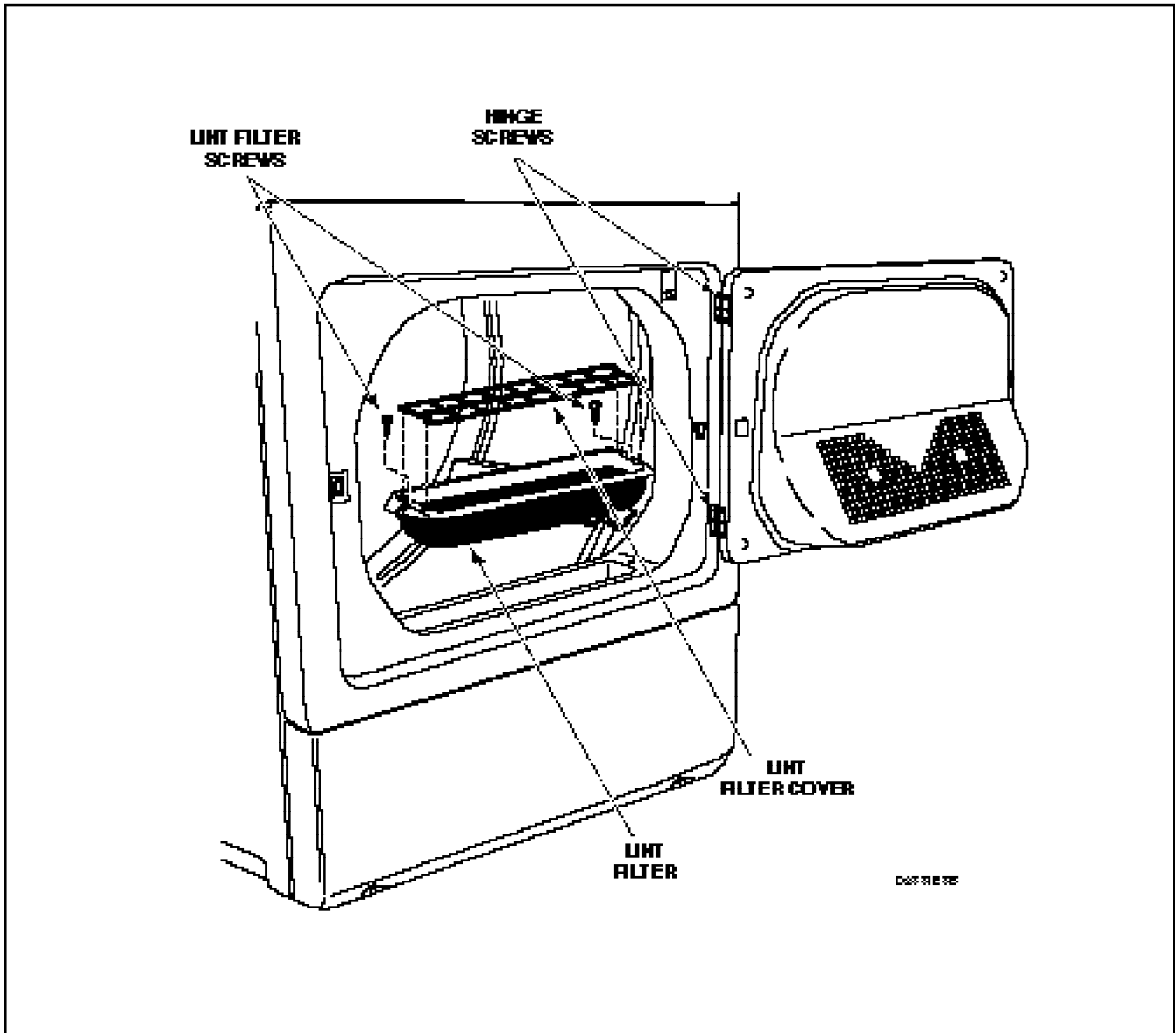

Figure 9

a **WARNING**

To reduce the risk of electric shock, fire, explosion, serious injury or death:

- Disconnect electric power to the dryer before servicing.
- Close gas shut-off valve to gas dryer before servicing.
- Never start the dryer with any guards/panels removed.
- Whenever ground wires are removed during servicing, these ground wires must be reconnected to ensure that the dryer is properly grounded.

W001

15. INNER AND OUTER DOOR PANELS AND DOOR PULL

- Remove four screws holding door assembly to hinges, *Figure 9*.
- Remove screw from door pull, *Figure 11*, and the remaining screws around the door perimeter and separate panels, *Figure 11*.

NOTE: All screws are interchangeable except for the screw in the recessed door pull.

IMPORTANT: Do not over-tighten screws when reinstalling door pull.

16. LOADING DOOR

- Open loading door.
- Remove screws holding loading door to hinges, *Figure 9*.

REVERSING DOOR PROCEDURE

The door on this dryer is completely reversible. To reverse door proceed as follows:

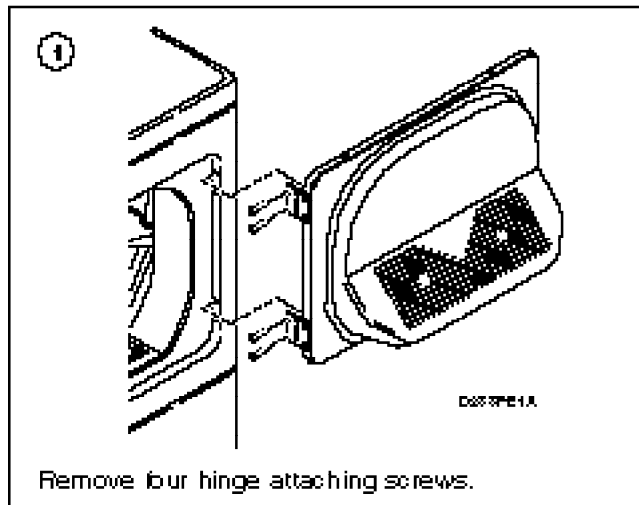

Figure 10

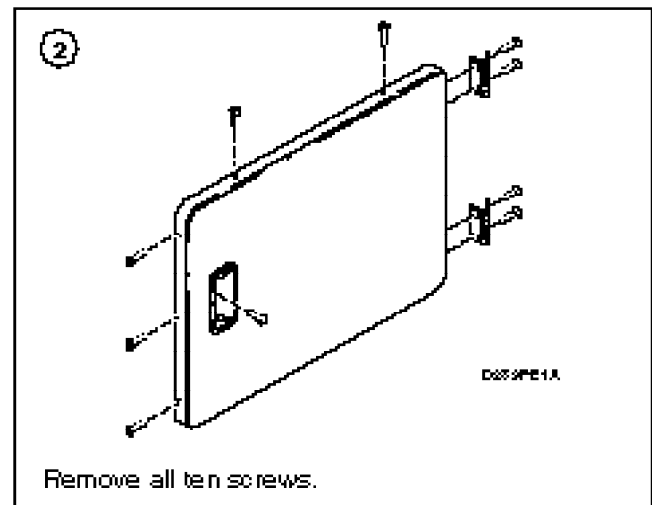

Figure 11

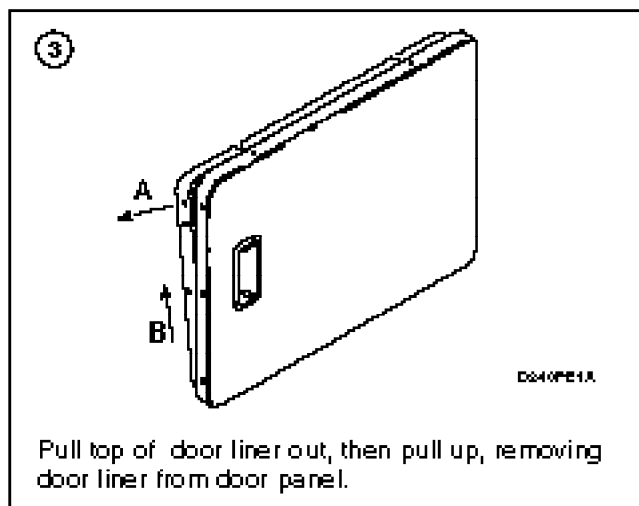

Figure 12

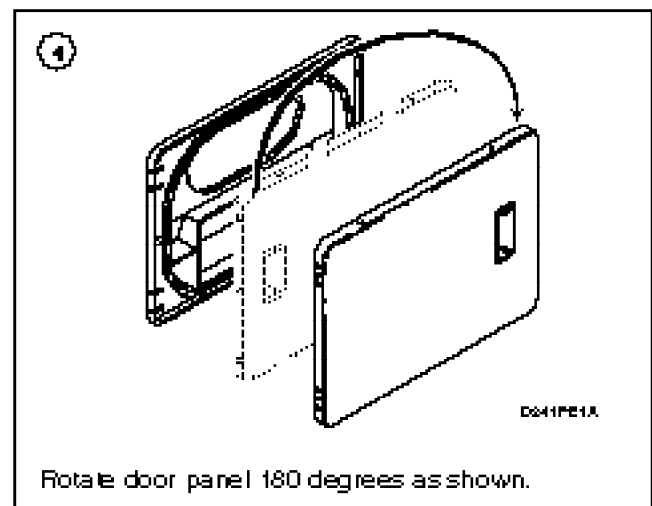

Figure 13

a WARNING

To reduce the risk of electric shock, fire, explosion, serious injury or death:

- Disconnect electric power to the dryer before servicing.
- Close gas shut-off valve to the gas dryer before servicing.
- Never start the dryer with any guards/panels removed.
- Whenever ground wires are removed during servicing, these ground wires must be reconnected to ensure that the dryer is properly grounded.

W001

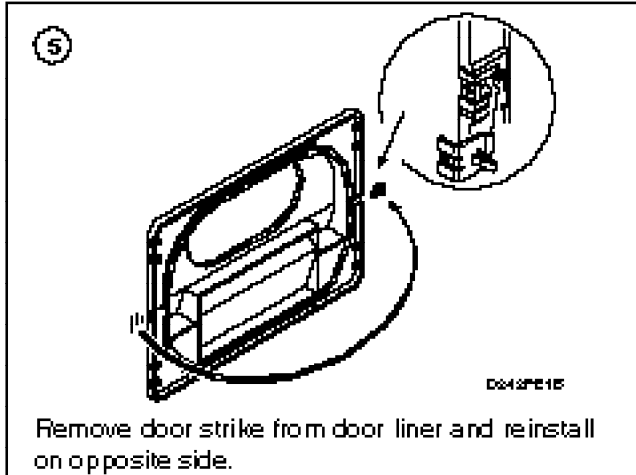

Figure 14

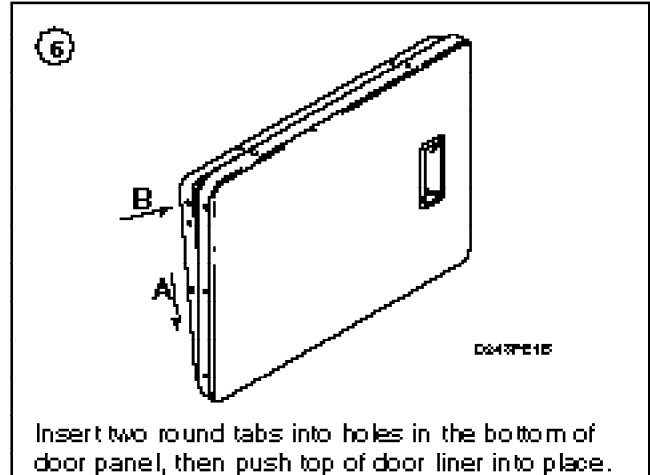

Figure 15

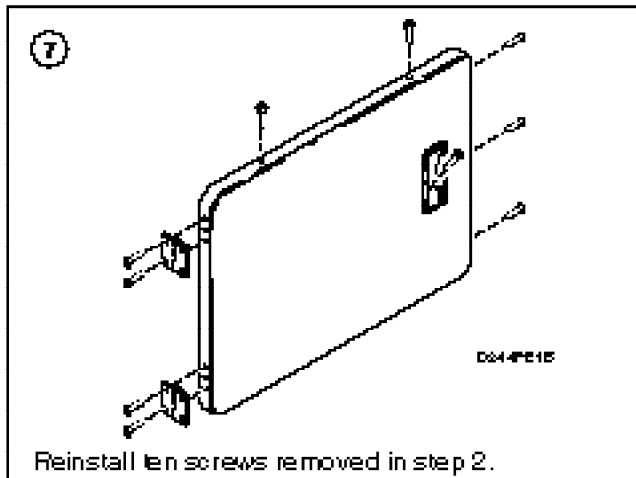

Figure 16

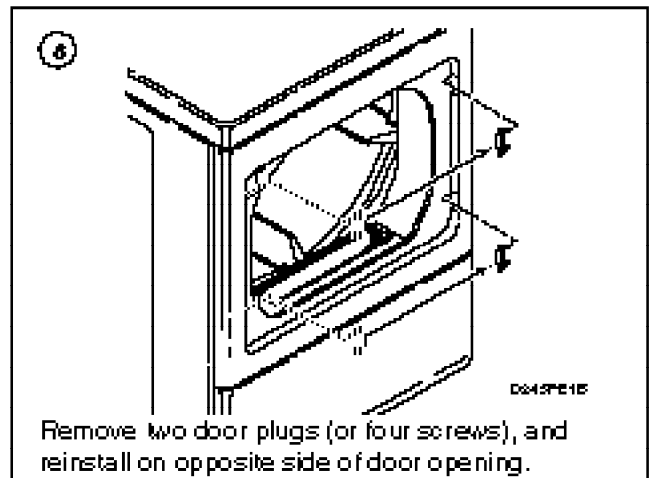

Figure 17

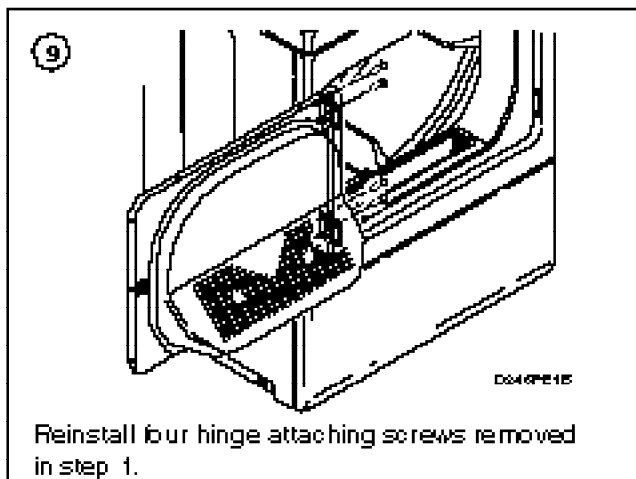
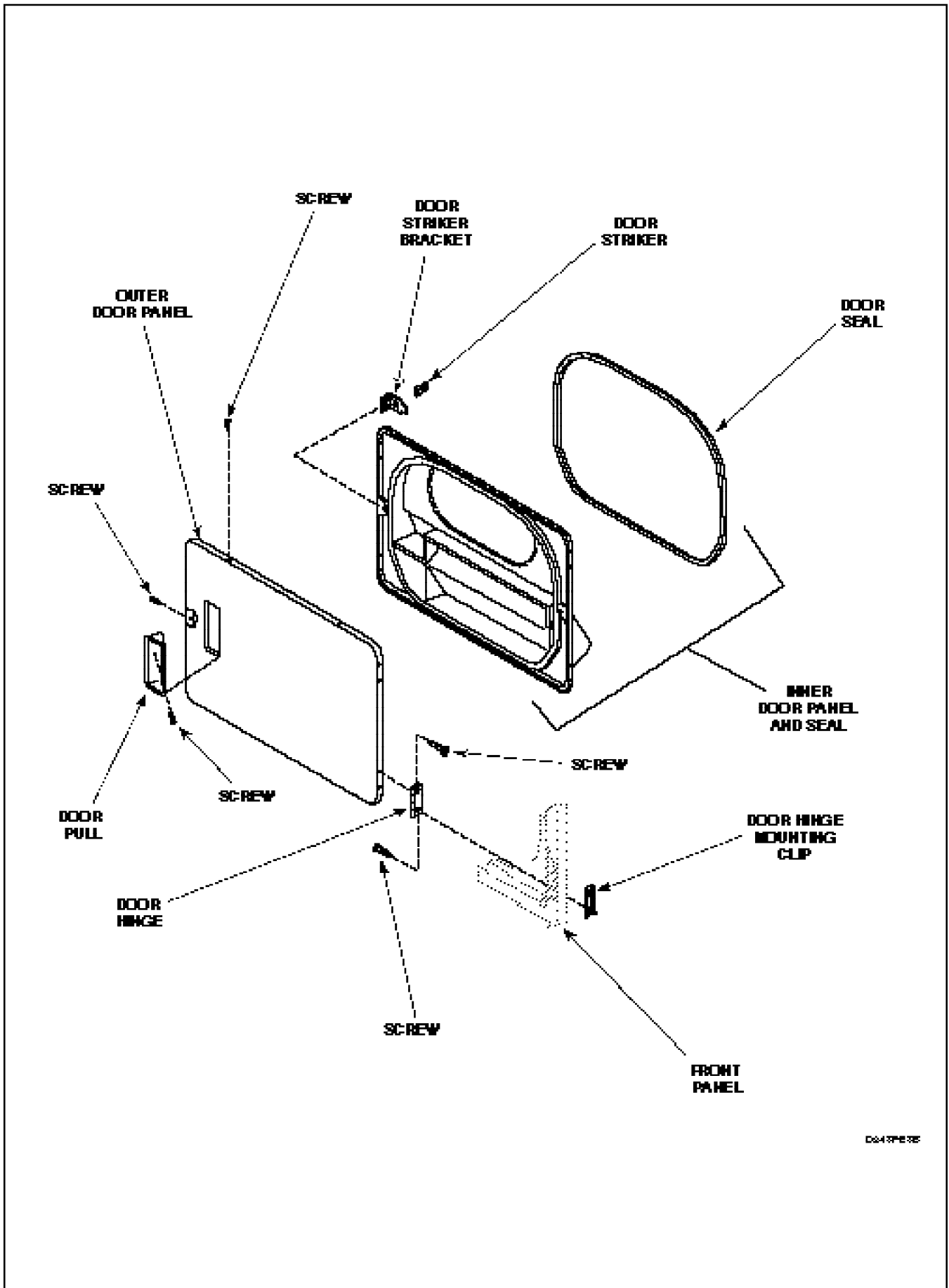

Figure 18



00439835

Figure 19

a **WARNING**

To reduce the risk of electric shock, fire, explosion, serious injury or death:

- Disconnect electric power to the dryer before servicing.
- Close gas shut-off valve to gas dryer before servicing.
- Never start the dryer with any guards/panels removed.
- Whenever ground wires are removed during servicing, these ground wires must be reconnected to ensure that the dryer is properly grounded.

W001

17. DOOR STRIKE

- Open loading door.
- Remove screw holding door strike and bracket to loading door, *Figure 19*, and remove strike and bracket.

NOTE: You may have to loosen the two screws on end of door to allow for striker and bracket removal.

18. DOOR SEAL

- Open loading door.
- Grasp either end of door seal at bottom of door and remove seal from tabs on inner door panel by gently pulling on the seal, *Figure 20*.

NOTE: When replacing seal, be sure seal is not stretched or distorted and the groove in the seal is installed on each tab on inner door panel, *Figure 20*, and the split in the seal is at the bottom of the door.

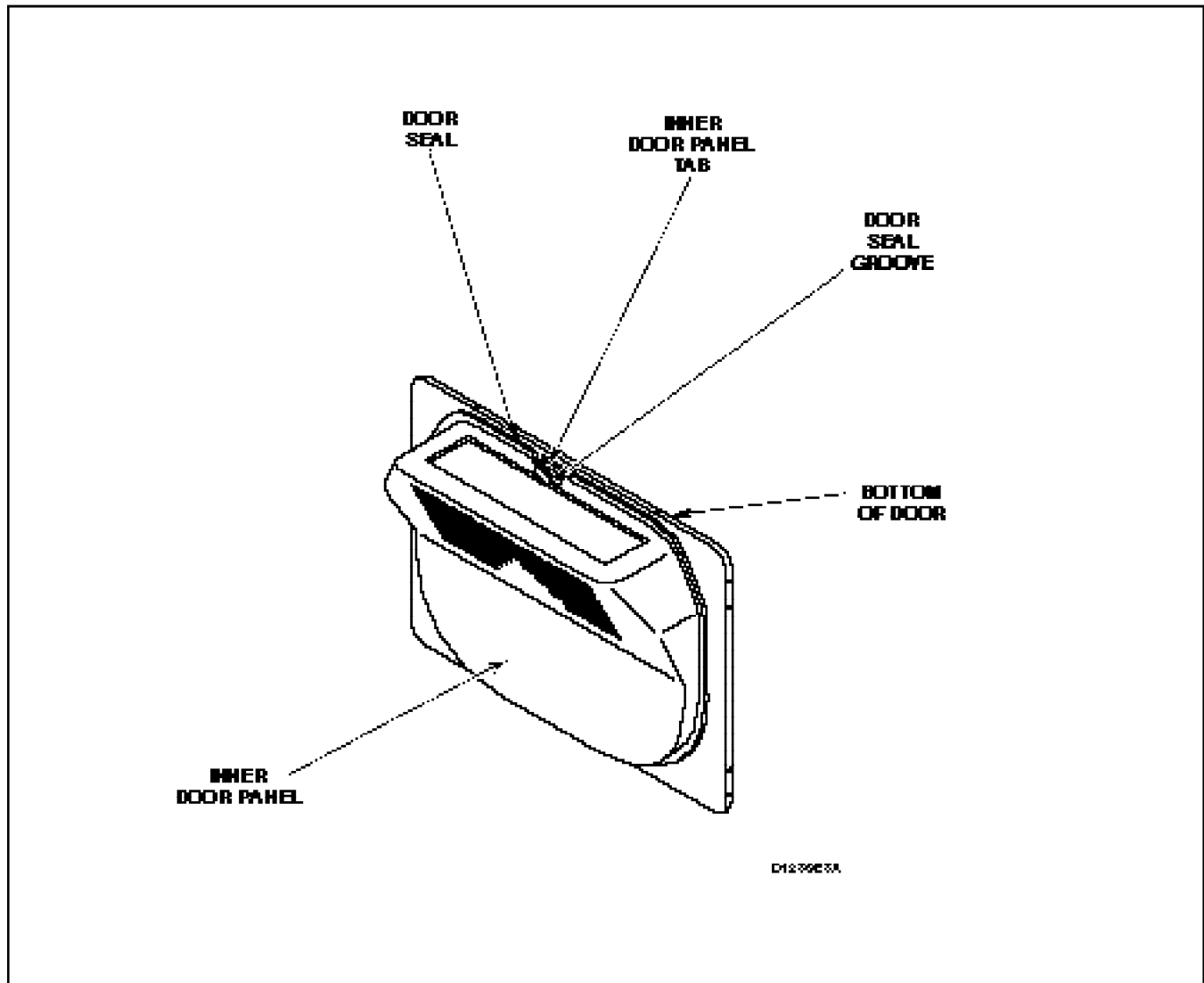

Figure 20

a WARNING

To reduce the risk of electric shock, fire, explosion, serious injury or death:

- Disconnect electric power to the dryer before servicing.
- Close gas shut-off valve to gas dryer before servicing.
- Never start the dryer with any guards/panels removed.
- Whenever ground wires are removed during servicing, these ground wires must be reconnected to ensure that the dryer is properly grounded.

W001

19. FRONT PANEL AND PANEL SEAL

- While supporting the lower access panel, remove two screws from bottom edge of lower access panel, *Figure 22*.
- Gently lower the access panel to disengage guide lugs from bottom edge of front panel.
- Remove two screws holding bottom tabs on front panel to dryer side panels, *Figure 22*. Swing bottom of front panel away from dryer far enough to disengage hold-down clips and guide lugs from cabinet top.
- Disconnect wires from door switch, *Figure 21*.

NOTE: Refer to appropriate wiring diagram when rewiring switch.

- Remove front panel seal from flange around inside of door opening, *Figure 22*.

NOTE: Be sure seal is properly positioned when installing on front panel.

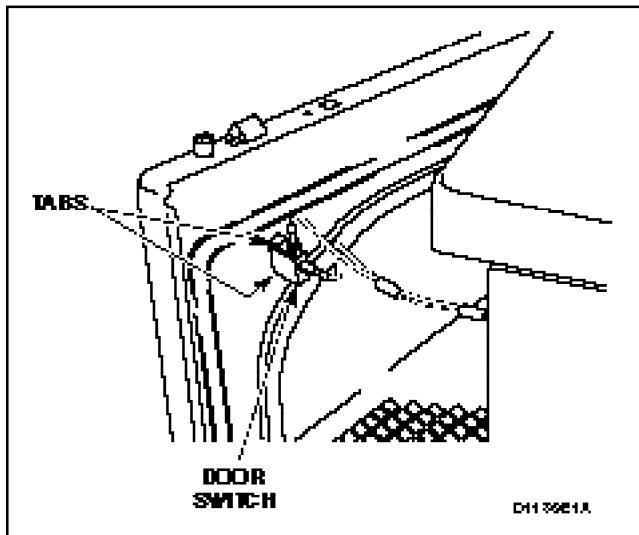

Figure 21

20. DOOR SWITCH

- While supporting the lower access panel, remove two screws from bottom edge of lower access panel, *Figure 22*.
- Gently lower the access panel to disengage guide lugs from bottom edge of front panel.
- Remove two screws holding tabs on front panel to dryer side panels, *Figure 22*. Swing bottom of front panel away from dryer far enough to disengage hold-down clips and guide lugs from cabinet top.
- Disconnect wires from door switch, *Figure 21*.

NOTE: Refer to appropriate wiring diagram when rewiring switch.

- Depress tabs on top and bottom of switch and push out of front panel, *Figure 21*.

21. STRIKE CATCH

- While supporting the lower access panel, remove two screws from bottom edge of lower access panel, *Figure 22*.
- Gently lower the access panel to disengage guide lugs from bottom edge of front panel.
- Remove two screws holding bottom tabs on front panel to dryer side panels, *Figure 22*. Swing bottom of front panel away from dryer far enough to disengage hold-down clips and guide lugs from cabinet top.
- Disconnect wires from door switch, *Figure 21*.

NOTE: Refer to appropriate wiring diagram when rewiring switch.

- Depress tabs on top and bottom of catch and push out of front panel, *Figure 21*.

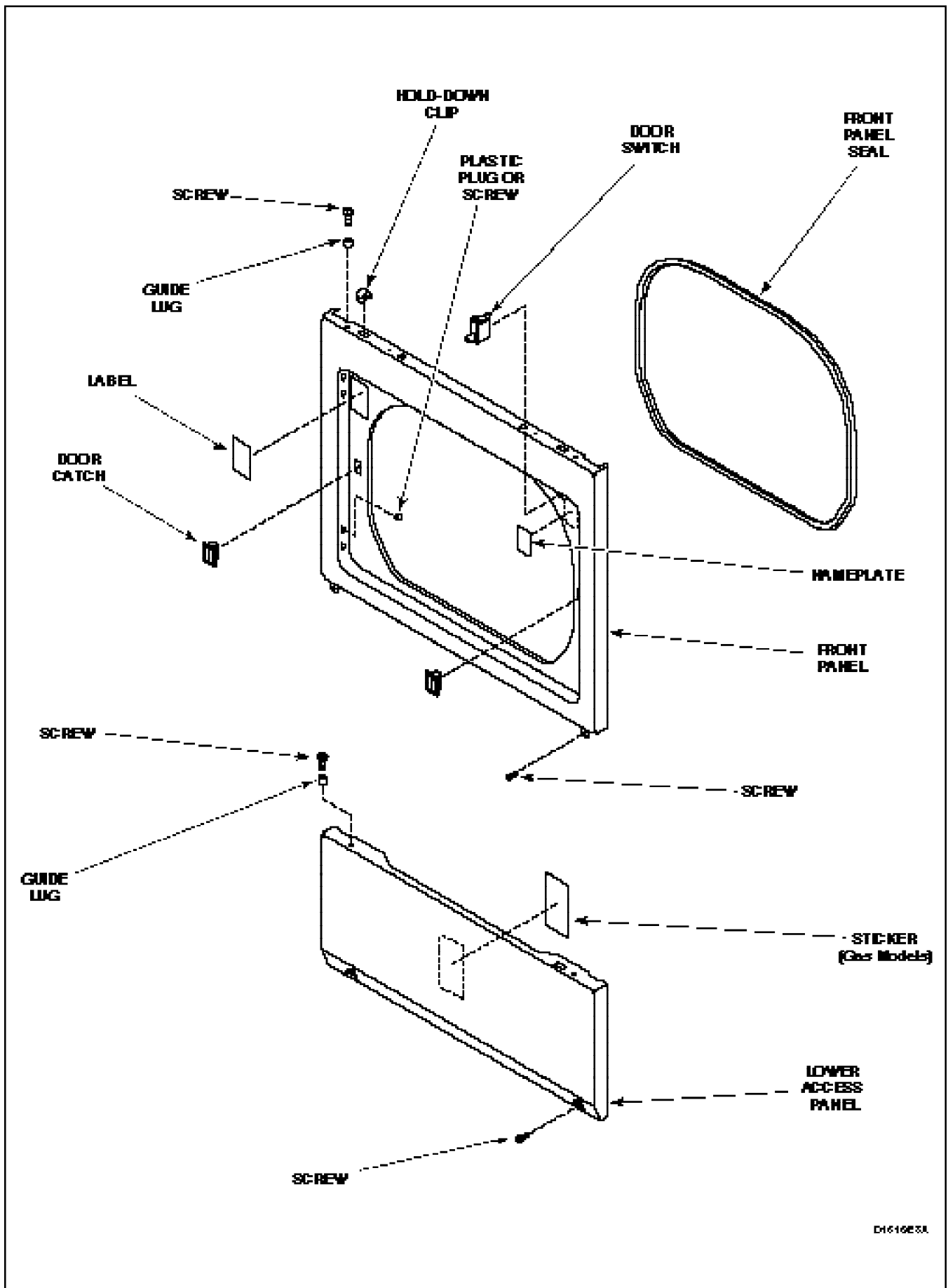

Figure 22

a **WARNING**

To reduce the risk of electric shock, fire, explosion, serious injury or death:

- Disconnect electric power to the dryer before servicing.
- Close gas shut-off valve to gas dryer before servicing.
- Never start the dryer with any guards/panels removed.
- Whenever ground wires are removed during servicing, these ground wires must be reconnected to ensure that the dryer is properly grounded.

W001

22. DOOR HINGE

- Open loading door and, while supporting door, remove four screws holding door assembly to hinges, *Figure 23*.
- Remove four screws holding hinges to front panel, *Figure 23*.

- Remove two screws holding bottom tabs on front panel to dryer side panels, *Figure 22*. Swing bottom edge of front panel away from dryer far enough to disengage hold-down clips and guide lugs from cabinet top.
- Disconnect wires from door switch, *Figure 21*.

23. HOLD-DOWN CLIPS AND GUIDE LUGS

- While supporting the lower access panel, remove two screws from bottom edge of lower access panel, *Figure 22*.
- Gently lower the access panel to disengage guide lugs from bottom edge of front panel.

NOTE: Refer to appropriate wiring diagram when rewiring switch.

- Compress hold-down clips and remove from slot in top flange of access panel or front panel.
- Remove four screws holding four guide lugs to access panel or front panel, *Figure 22*.

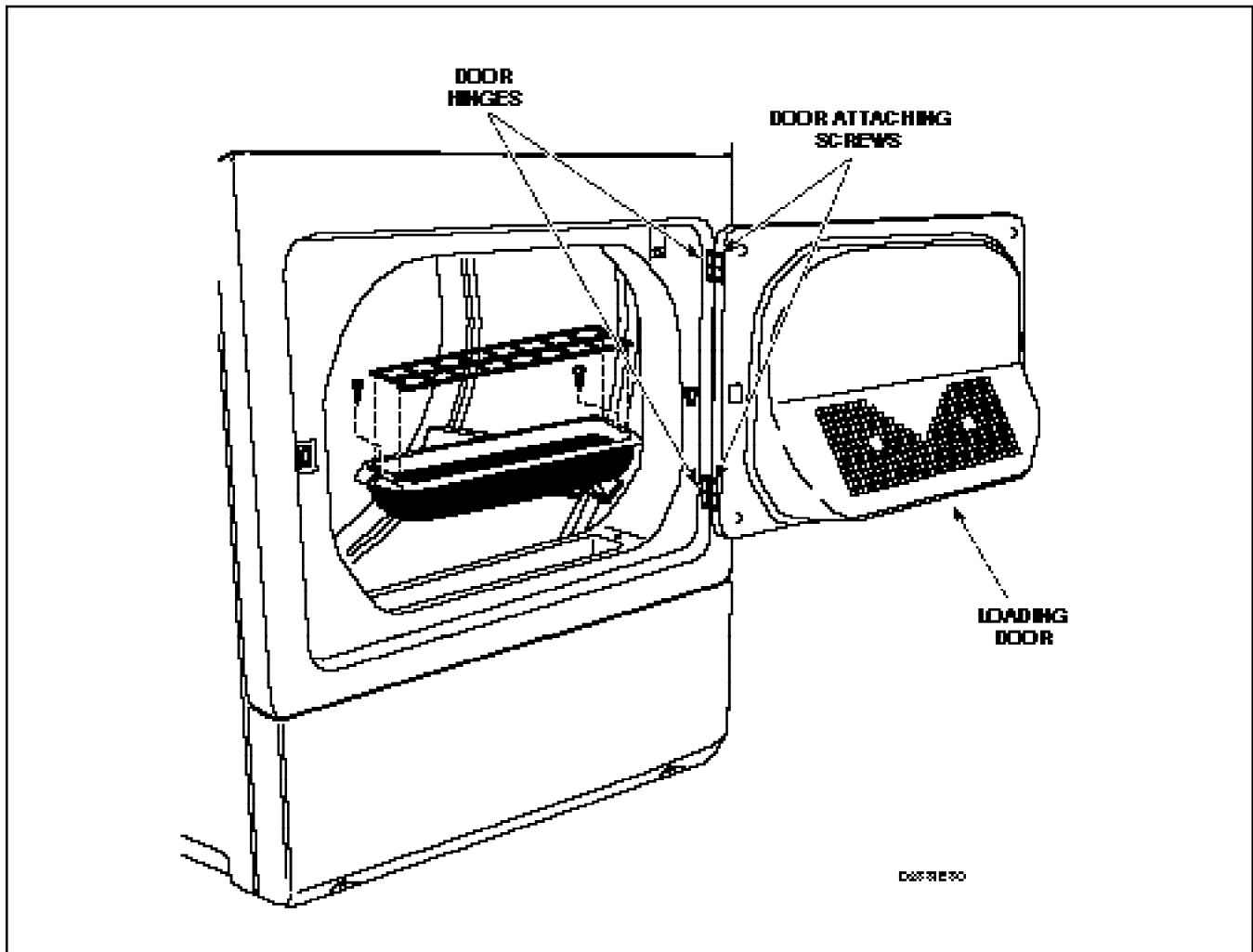

Figure 23

a WARNING

To reduce the risk of electric shock, fire, explosion, serious injury or death:

- Disconnect electric power to the dryer before servicing.
- Close gas shut-off valve to the dryer before servicing.
- Never start the dryer with any guards/panels removed.
- Whenever ground wires are removed during servicing, these ground wires must be reconnected to ensure that the dryer is properly grounded.

W001

24. BURNER SYSTEM COMPONENTS - Gas Models

a. Complete Gas Valve Assembly.

- (1) While supporting the lower access panel, remove two screws from bottom edge of lower access panel, *Figure 22*.
- (2) Gently lower the access panel to disengage guide lugs from bottom edge of front panel.
- (3) Close gas shut-off valve, disconnect igniter wires at disconnect blocks, sensor wires from flame sensor terminals, and wires from gas valve coils at the quick disconnect blocks, *Figure 24*.

- (4) Disconnect gas shut-off valve from gas valve at the union nut, *Figure 24*.
- (5) Remove three screws holding valve and mounting bracket to base, *Figure 24*.
- (6) Lift gas valve and mounting bracket from base, *Figure 24*.

NOTE: The holding and booster coil, and secondary coil can be replaced individually.

b. Burner Tube, Igniter and Bracket

NOTE: Burner tube and igniter can be removed without removing gas valve and bracket.

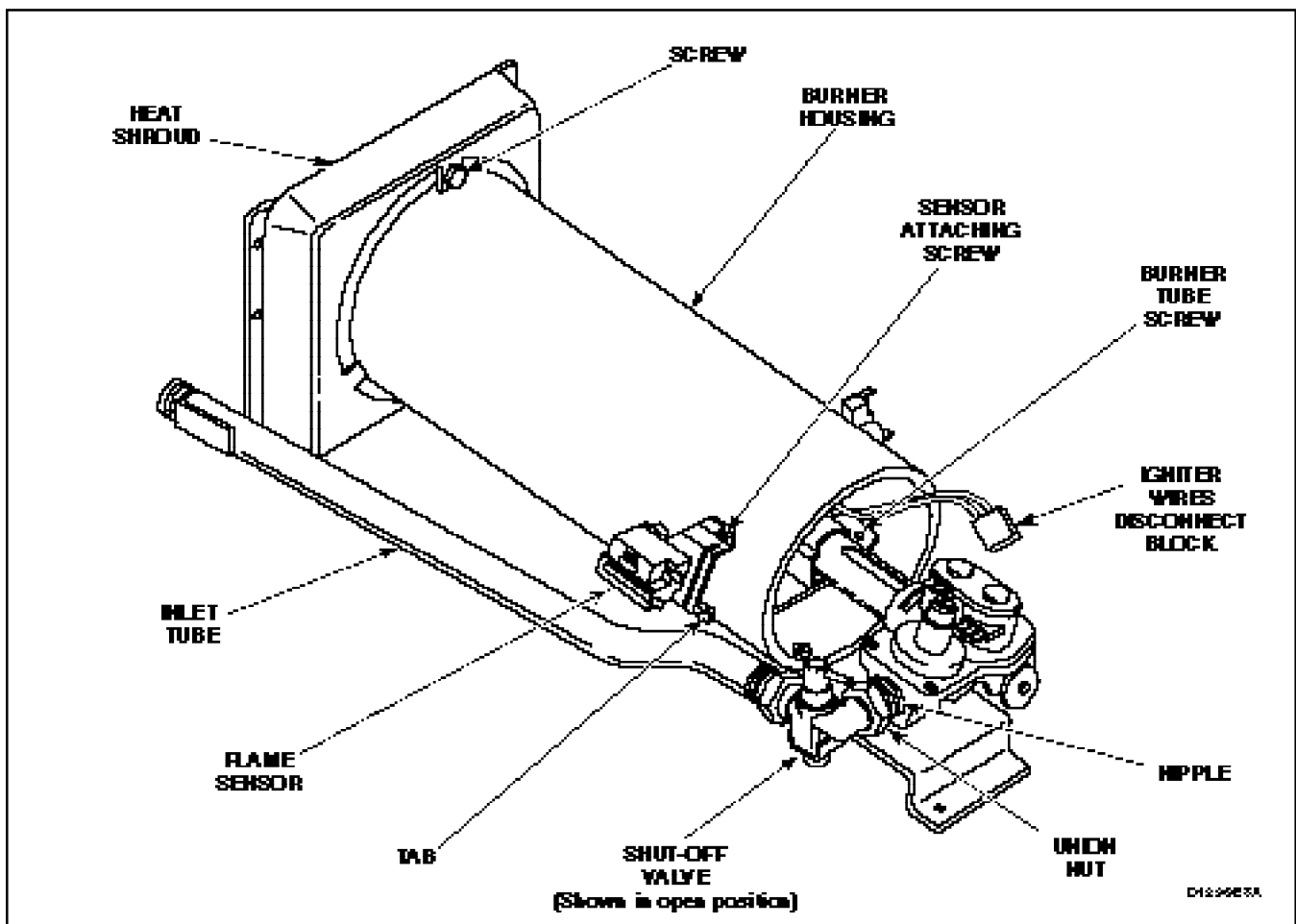

Figure 24

a **WARNING**

To reduce the risk of electric shock, fire, explosion, serious injury or death:

- Disconnect electric power to the dryer before servicing.
- Close gas shut-off valve to the gas dryer before servicing.
- Never start the dryer with any guards/panels removed.
- Whenever ground wires are removed during servicing, these ground wires must be reconnected to ensure that the dryer is properly grounded.

W001

- (1) Remove one screw from right side of burner housing holding burner tube in place, *Figure 26*.
- (2) Gently move burner tube toward rear of dryer to disengage tab from slot on left side of burner housing, *Figure 24*.
- (3) Carefully rotate burner tube and igniter counterclockwise so tab is at 8 o'clock position.
- (4) Move air shutter end of burner tube slightly to right and CAREFULLY remove burner tube and igniter assembly out through front of dryer.
- (5) Remove screw holding igniter and bracket to burner tube and remove igniter and bracket, *Figure 25*.

IMPORTANT: Use care while removing igniter to avoid damaging or breaking it. The igniter is very fragile.

IMPORTANT: Handle igniter by grasping the white ceramic portion of bracket only. DO NOT handle silicon carbide portion of igniter with hands or allow any oil, grease or other foreign material to contaminate it. Oil, grease and other impurities or hairline cracks will cause the igniter to burn out.

c. **Flame Sensor**, *Figure 24*.

- (1) While supporting the lower access panel, remove two screws from bottom edge of lower access panel, *Figure 22*.
- (2) Gently lower the access panel to disengage guide lugs from bottom edge of front panel.
- (3) Remove wires from sensor terminals, *Figure 24*.
- (4) Remove screw holding sensor to burner housing, *Figure 24*.

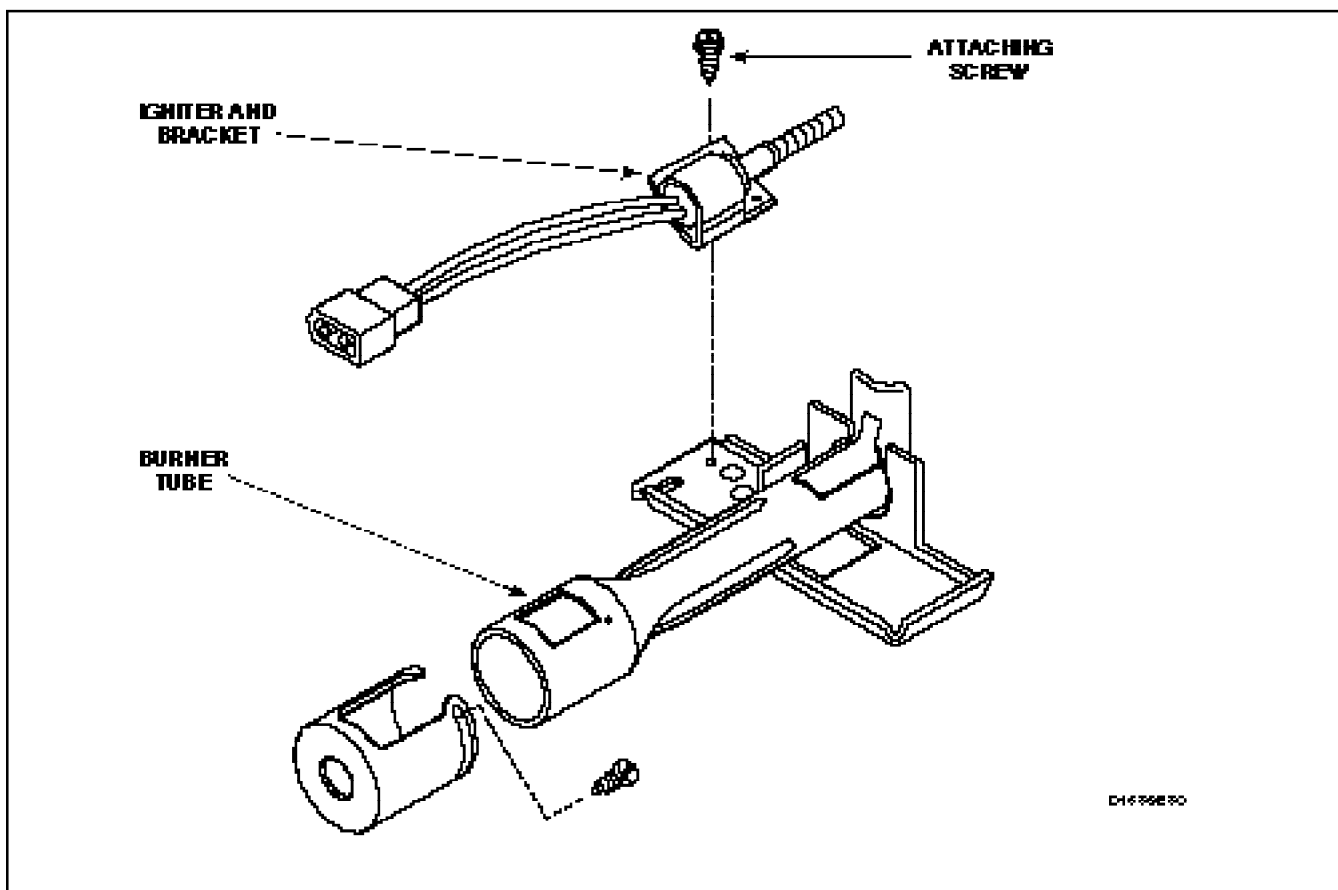

Figure 25

a **WARNING**

To reduce the risk of electric shock, fire, explosion, serious injury or death:

- Disconnect electric power to the dryer before servicing.
- Close gas shut-off valve to gas dryer before servicing.
- Never start the dryer with any guards/panels removed.
- Whenever ground wires are removed during servicing, these ground wires must be reconnected to ensure that the dryer is properly grounded.

W001

25. BURNER HOUSING AND HEAT SHROUD

- While supporting the lower access panel, remove two screws from bottom edge of lower access panel, *Figure 22*.
- Gently lower the access panel to disengage guide lugs from bottom edge of front panel.
- Disconnect igniter wires at disconnect blocks, sensor wires from flame sensor terminals, and wires from gas valve coils at the quick disconnect blocks, *Figure 24*.
- Remove screw from right side of burner housing, while holding burner tube in place, *Figure 26*.
- Gently move burner tube toward rear of dryer to disengage tab from slot on left side of burner housing, *Figure 24*.
- Carefully rotate burner tube and igniter counterclockwise so tab is at 8 o'clock position.
- Move air shutter end of burner tube slightly to right and CAREFULLY remove burner tube and igniter assembly out through front of dryer.

IMPORTANT: The igniter is very fragile. Be careful not to damage it during removal.

- Remove screw holding burner housing to heat shroud, *Figure 24*.
- Remove screw holding front of burner housing to dryer base and remove housing out through front of dryer, *Figure 26*.

- Remove two screws holding shroud to heater box and take shroud out through front of dryer.

26. LIMIT THERMOSTAT

- While supporting the lower access panel, remove two screws from bottom edge of lower access panel, *Figure 22*.
- Gently lower the access panel to disengage guide lugs from bottom edge of front panel.
- Disconnect wires and remove screws attaching limit thermostat to burner housing or element plate, *Figure 26*.

27. HEATING ELEMENT

- While supporting the lower access panel, remove two screws from bottom edge of lower access panel, *Figure 22*.
- Gently lower the access panel to disengage guide lugs from bottom edge of front panel.
- Remove two screws holding element and plate to heater box and pull element down and away from heater box, *Figure 26*.
- Disconnect wires from element and plate, *Figure 26*.
- Remove screws holding thermostat and thermal fuse to element and plate, *Figure 26*.

NOTE: When reassembling, be sure all wire connectors are tight on element terminals, thermal fuse and limit thermostat.

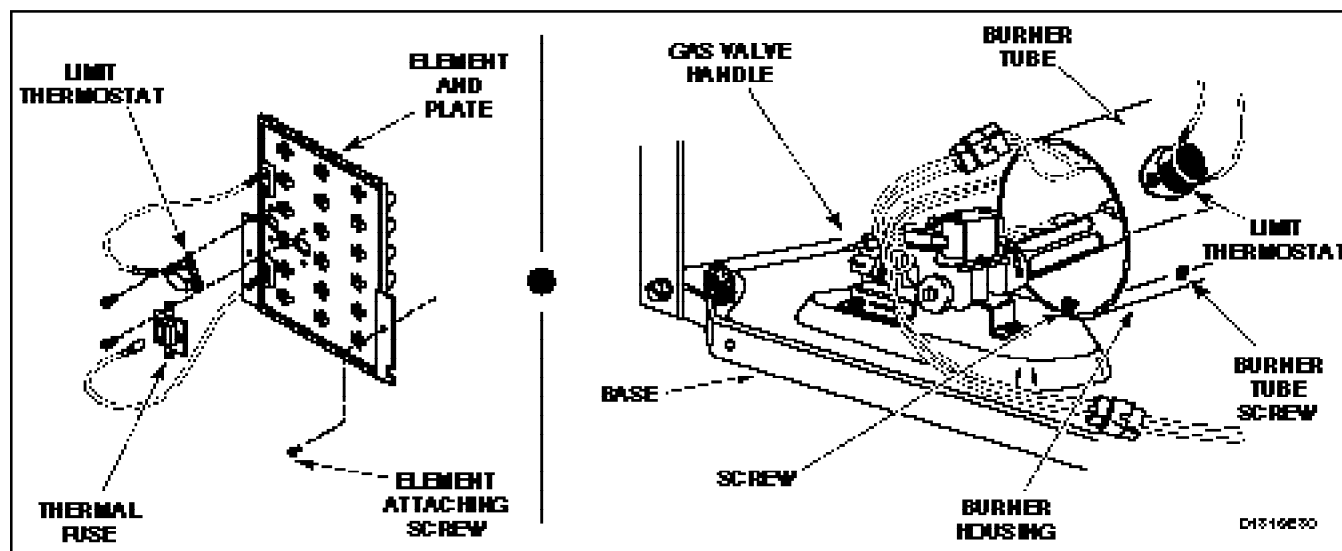

Figure 26

a **WARNING**

To reduce the risk of electric shock, fire, explosion, serious injury or death:

- Disconnect electric power to the dryer before servicing.
- Close gas shut-off valve to gas dryer before servicing.
- Never start the dryer with any guards/panels removed.
- Whenever ground wires are removed during servicing, these ground wires must be reconnected to ensure that the dryer is properly grounded.

W001

28. THERMISTOR OR THERMOSTAT AND HEATER

- While supporting the lower access panel, remove two screws from bottom edge of lower access panel, *Figure 22*.
- Gently lower the access panel to disengage guide lugs from bottom edge of front panel.
- Disconnect wires and remove thermostat attaching screws, *Figure 27*, and remove thermostat and heater.

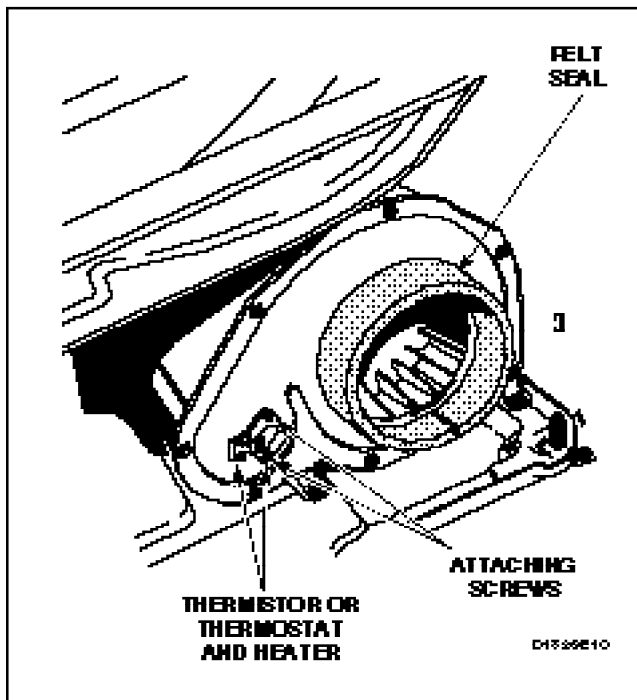

Figure 27

29. FRONT AIR DUCT

- While supporting the lower access panel, remove two screws from bottom edge of lower access panel, *Figure 22*.
- Gently lower the access panel to disengage guide lugs from bottom edge of front panel.
- Open loading door, remove lint filter screws and lift filter out of bulkhead, *Figure 9*.

IMPORTANT: When installing lint filter, be sure to install the filter with the word “FRONT” facing the front of the dryer. If filter is installed backwards, lint will accumulate in exhaust system, causing fire and machine malfunction.

- Remove two screws holding duct to front bulkhead and remove air duct, *Figure 28*.

a **WARNING**

To reduce the risk of serious injury or death by carbon monoxide and other gases in gas dryers, carefully read and follow all instructions given in this section.

W005

IMPORTANT: When reassembling, be sure felt seal on exhaust fan cover makes airtight seal on flange of duct, *Figure 27*. If the seal is installed improperly, the airflow through the exhaust system will be restricted which can adversely affect dryer performance.

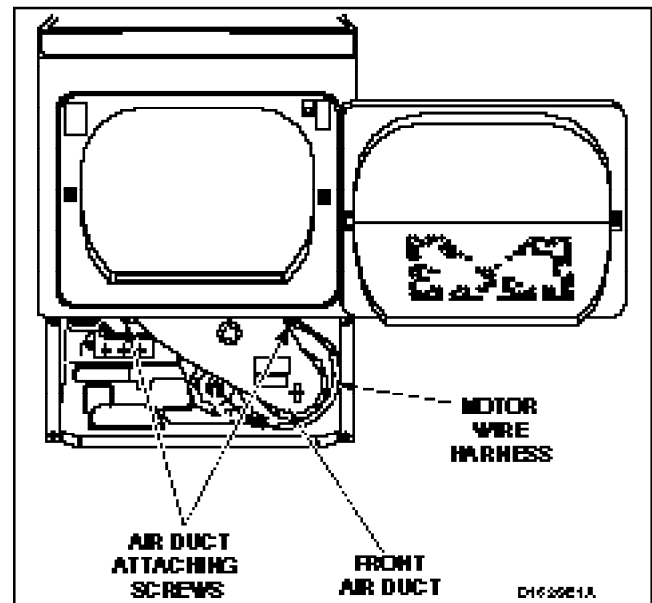

Figure 28

a WARNING

To reduce the risk of electric shock, fire, explosion, serious injury or death:

- Disconnect electric power to the dryer before servicing.
- Close gas shut-off valve to gas dryer before servicing.
- Never start the dryer with any guards/panels removed.
- Whenever ground wires are removed during servicing, these ground wires must be reconnected to ensure that the dryer is properly grounded.

W001

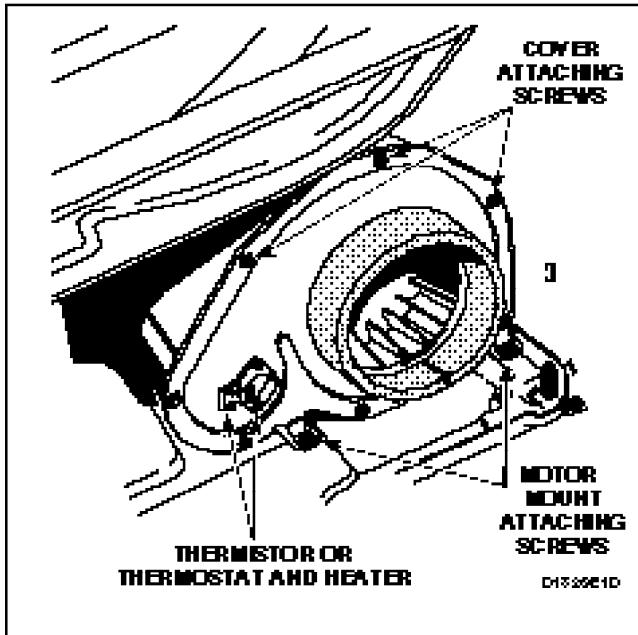

Figure 29

30. MOTOR AND EXHAUST ASSEMBLY

- While supporting the lower access panel, remove two screws from bottom edge of lower access panel, *Figure 22*.
- Gently lower the access panel to disengage guide lugs from bottom edge of front panel.
- Open loading door, remove lint filter screws and lift filter out of bulkhead, *Figure 9*.

a WARNING

When installing lint filter, be sure to install the filter with the word "FRONT" facing the front of the dryer. If filter is installed backwards, lint will accumulate in exhaust system, increasing the risk of fire and machine malfunction.

- Remove screws holding air duct to front bulkhead and remove air duct, *Figure 28*.

a WARNING

To reduce the risk of serious injury or death by carbon monoxide and other gases in gas dryers, carefully read and follow all instructions given in this section.

W005

IMPORTANT: When reassembling, be sure felt seal on exhaust fan cover makes airtight seal on flange of duct, *Figure 27*. If the seal is installed improperly, the airflow through the exhaust system will be restricted which can adversely affect dryer performance.

- Disconnect wires from thermostat/thermistor and heater, *Figure 26*.

NOTE: Refer to appropriate wiring diagram when rewiring thermostat and heater.

- Remove cylinder belt from idler and motor pulleys, *Figure 30*.
- Disengage motor wire harness terminal block from motor switch by pressing in on the movable locking tabs (located on each end of the terminal block) and pulling away from motor, *Figure 33*.
- Remove two screws holding motor mounting bracket to dryer base, *Figure 29*.

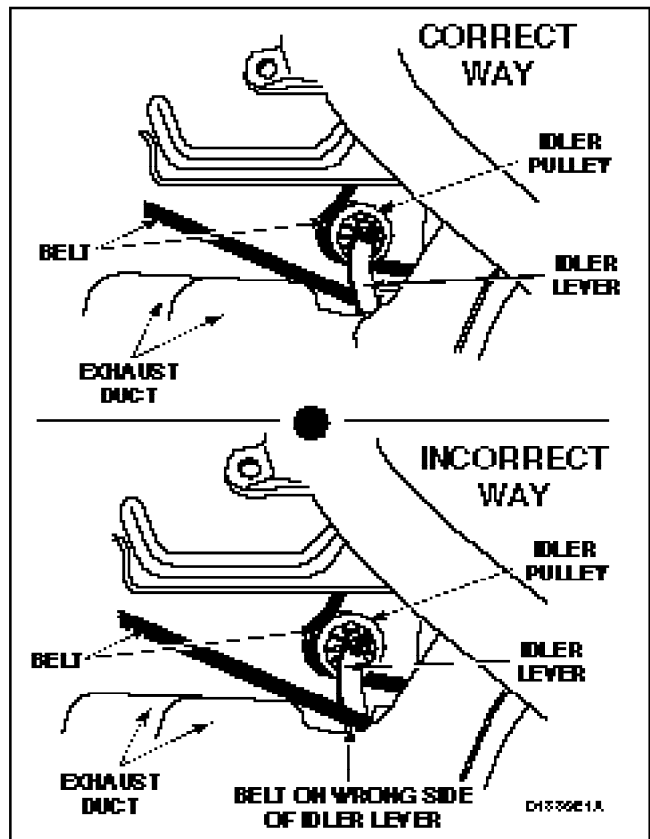

Figure 30

a WARNING

To reduce the risk of electric shock, fire, explosion, serious injury or death:

- Disconnect electric power to the dryer before servicing.
- Close gas shut-off valve to gas dryer before servicing.
- Never start the dryer with any guards/panels removed.
- Whenever ground wires are removed during servicing, these ground wires must be reconnected to ensure that the dryer is properly grounded.

W001

a WARNING

To reduce the risk of serious injury or death by carbon monoxide and other gases in gas dryers, carefully read and follow all instructions given in this section.

W005

IMPORTANT: When reassembling, be sure felt seal on exhaust fan cover makes airtight seal on flange of duct, *Figure 27*. If the seal is installed improperly, the airflow through the exhaust system will be restricted which can adversely affect dryer performance.

IMPORTANT: When reinstalling motor and exhaust assembly, be sure wire harness on right side is clipped to motor mounting bracket and is routed along dryer base (between motor mounting bracket and right side of cabinet), *Figure 28*. Tab on rear of motor mounting bracket must be slid into slot in dryer base. Be sure the belt has been installed on the correct side of the idler lever, *Figure 30*.

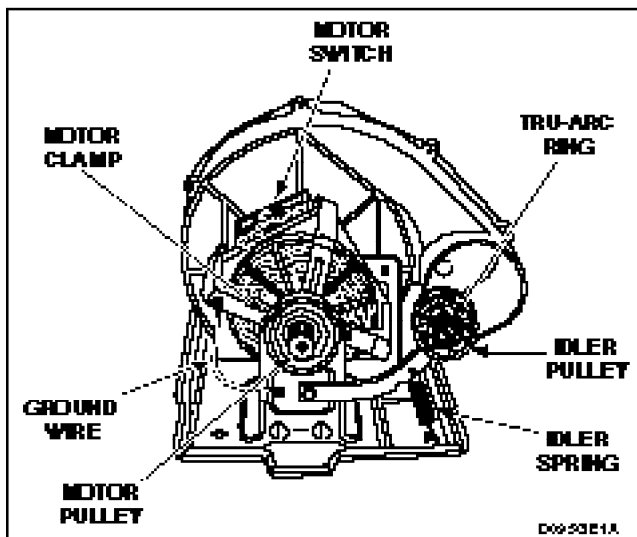

Figure 31

- i. Pull assembly forward and disengage the middle exhaust duct.
- j. Rotate the assembly 90° counterclockwise and slide out of machine.
- k. **Motor pulley and idler pulley assemblies.**

Refer to *Figure 31* for motor and idler pulley removal.

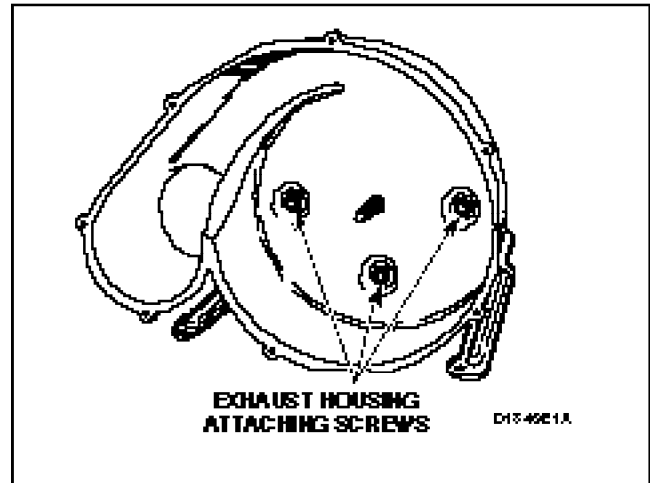

Figure 32

NOTE: Unthread motor pulley from motor shaft (left hand thread).

NOTE: When repairing or replacing the idler arm, it is important to make sure the idler arm moves freely. To ensure that the idler arm can move freely, proceed as follows:

- (1) Unhook idler spring.
- (2) Lift idler arm approximately 3 inches and release. If idler arm does not fall back to the base of the motor mount, then idler arm bolt is too tight.
- (3) Loosen idler arm bolt 1/4 turn.
- (4) Add grease between idler arm and motor mount.
- (5) If condition persists, replace idler arm and bolt.

l. Impeller and housing.

- (1) Remove screws holding cover to housing, *Figure 29*.
- (2) Hold motor pulley securely and unthread impeller from motor shaft (right hand thread). Use a 7/8 inch, 6 point socket to aid in the removal of the impeller.
- (3) Remove three screws holding the exhaust housing to the motor mounting bracket, *Figure 32*.

a WARNING

To reduce the risk of electric shock, fire, explosion, serious injury or death:

- Disconnect electric power to the dryer before servicing.
- Close gas shut-off valve to gas dryer before servicing.
- Never start the dryer with any guards/panels removed.
- Whenever ground wires are removed during servicing, these ground wires must be reconnected to ensure that the dryer is properly grounded.

W001

m. Motor.

- (1) Disengage motor wire harness terminal block from the motor by pressing in on the movable locking tabs (located on each side of the terminal block) and pulling away from motor, *Figure 33*.

IMPORTANT: To avoid an open circuit, DO NOT pull on the terminal block wires when removing blocks from motor as this could damage the wires or terminal crimping.

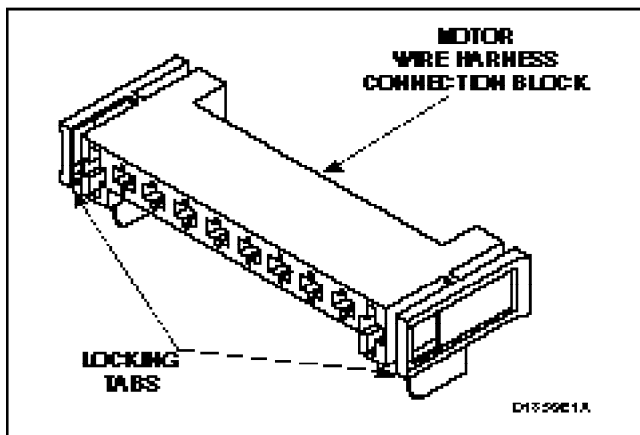

Figure 33

Before attaching wire harness terminal block to motor, be sure all the male terminals on motor are straight and are capable of accepting the terminals from the wire harness terminal block.

- (2) Disconnect ground wire from motor, *Figure 31*.
- (3) Pry two motor clamps off motor mounting bracket with screwdriver, *Figure 31*, then lift motor out of mounting bracket.

NOTE: When replacing motor, motor switch location should be at 10 o'clock position with the positioning tab on the motor engaged with the anti-rotating notch in the motor bracket.

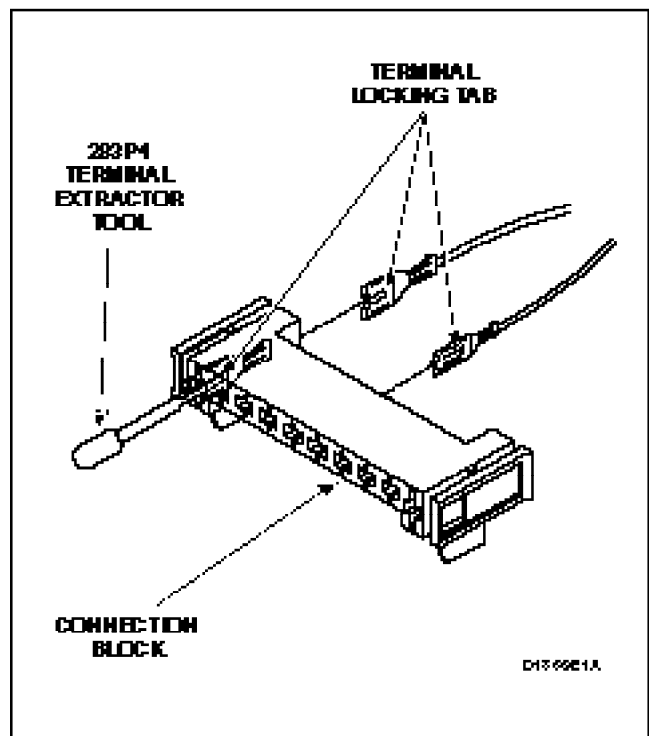

Figure 34

a **WARNING**

To reduce the risk of electric shock, fire, explosion, serious injury or death:

- Disconnect electric power to the dryer before servicing.
- Close gas shut-off valve to gas dryer before servicing.
- Never start the dryer with any guards/panels removed.
- Whenever ground wires are removed during servicing, these ground wires must be reconnected to ensure that the dryer is properly grounded.

W001

31. CABINET TOP

- While supporting the lower access panel, remove two screws from bottom edge of lower access panel, *Figure 22*.
- Gently lower the access panel to disengage guide lugs from bottom edge of front panel.
- Remove two screws holding bottom tabs on front panel to dryer side panels, *Figure 22*. Swing bottom of front panel away from dryer far enough to disengage hold-down clips and guide lugs from cabinet top.
- Disconnect wires from door switch, *Figure 21*.

- Remove two cabinet top hold-down screws, *Figure 35*.
- Lift cabinet top to a vertical position by hinging it on the rear top hinges, *Figure 35*.

NOTE: Cabinet top may be raised and hinged on the rear hold-down hinges or supported against wall behind dryer while servicing.

- Carefully withdraw wire harness through hole in cabinet top and lift the top off the top hinges, *Figure 35*.

NOTE: Refer to appropriate wiring diagram when rewiring switch.

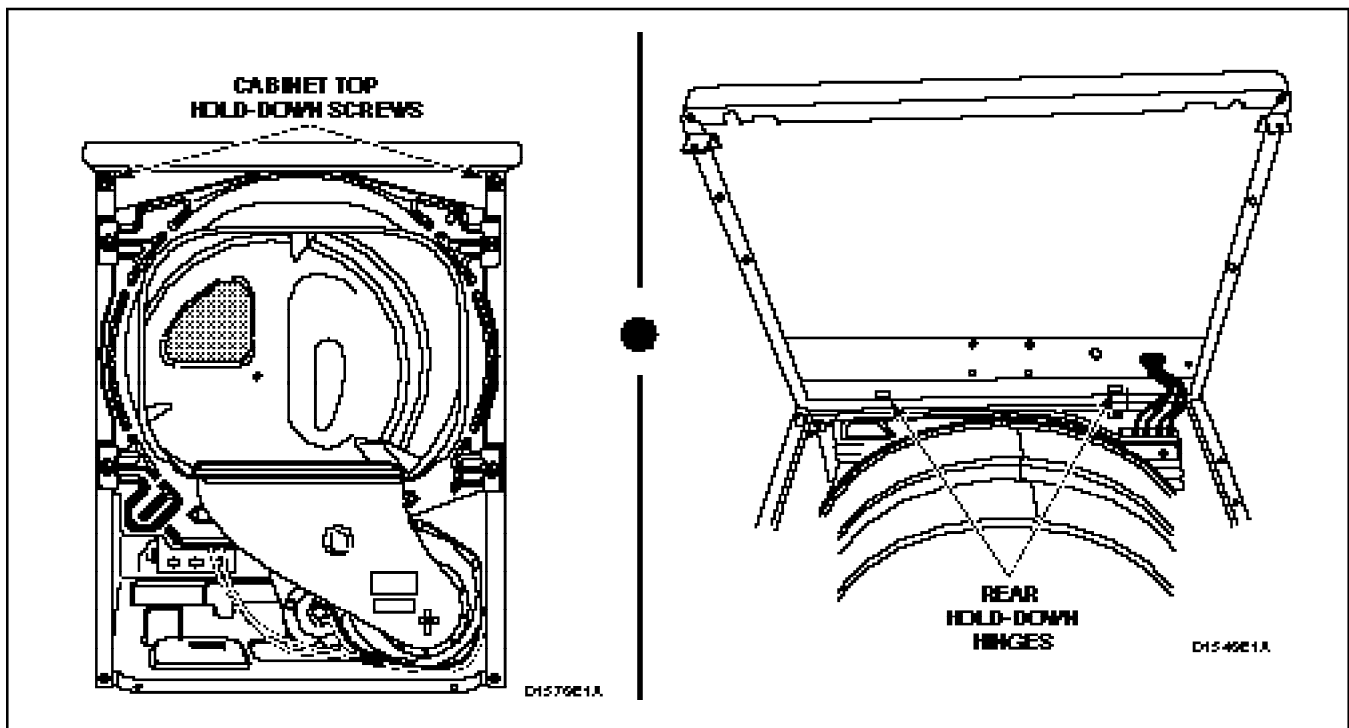

Figure 35

a **WARNING**

To reduce the risk of electric shock, fire, explosion, serious injury or death:

- Disconnect electric power to the dryer before servicing.
- Close gas shut-off valve to gas dryer before servicing.
- Never start the dryer with any guards/panels removed.
- Whenever ground wires are removed during servicing, these ground wires must be reconnected to ensure that the dryer is properly grounded.

W001

32. CYLINDER LIGHT (Figure 36)

- Open loading door and remove screws holding the lens to the front bulkhead.
- Turn the bulb counterclockwise and twist out of light receptacle.

- Disconnect wires from door switch, Figure 21.
- Open loading door and remove screws holding the lens to the front bulkhead, Figure 36.
- Disconnect wires from light receptacle terminals.

33. CYLINDER LIGHT RECEPTACLE (Figure 36)

- While supporting the lower access panel, remove two screws from bottom edge of lower access panel, Figure 22.
- Gently lower the access panel to disengage guide lugs from bottom edge of front panel.

NOTE: Refer to appropriate wiring diagram when rewiring switch.

- Remove two screws holding receptacle to front bulkhead, Figure 36.
- Lift light receptacle out of front bulkhead.

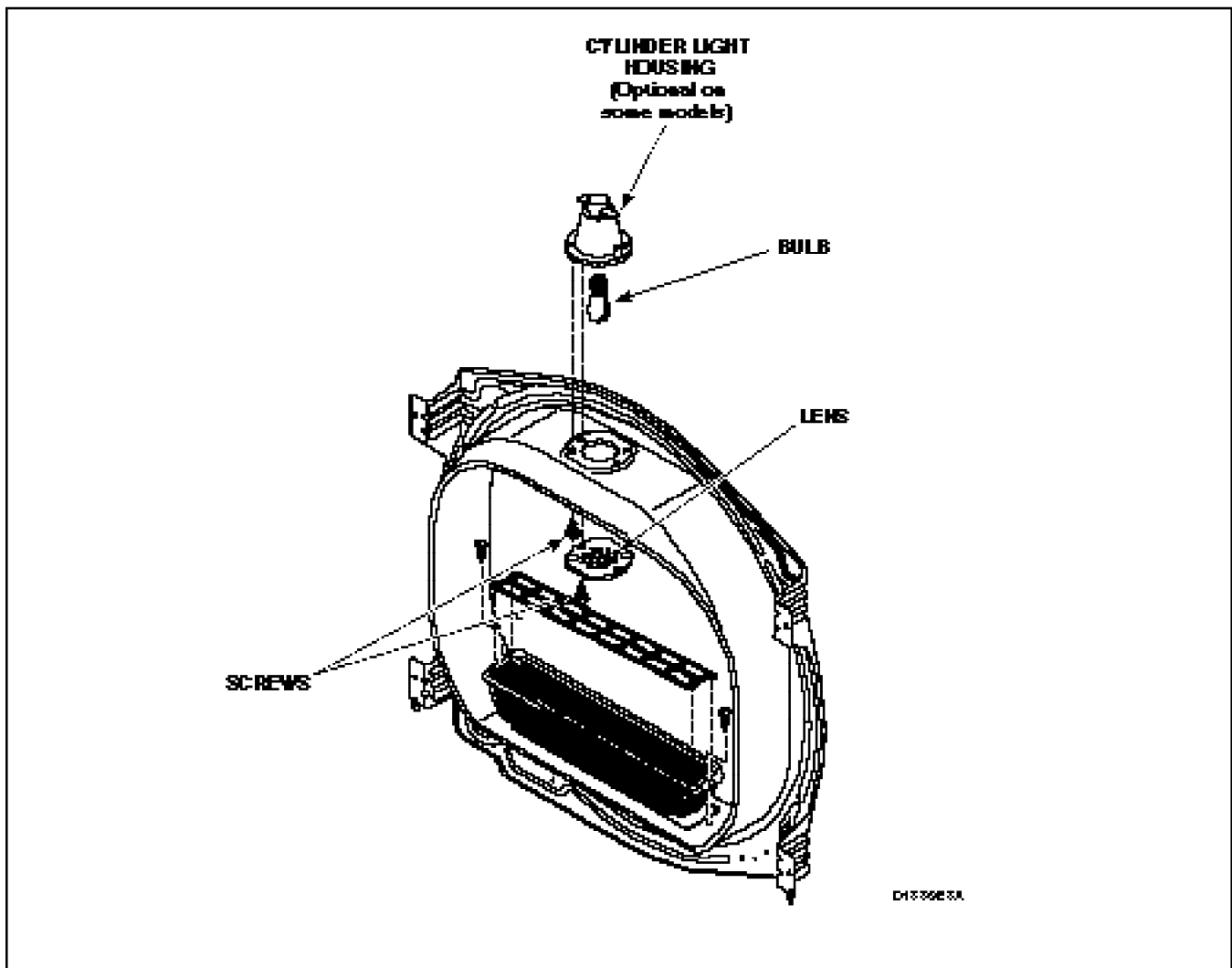

Figure 36

a **WARNING**

To reduce the risk of electric shock, fire, explosion, serious injury or death:

- Disconnect electric power to the dryer before servicing.
- Close gas shut-off valve to the dryer before servicing.
- Never start the dryer with any guards/panels removed.
- Whenever ground wires are removed during servicing, these ground wires must be reconnected to ensure that the dryer is properly grounded.

W001

34. FRONT BULKHEAD ASSEMBLY

- While supporting the lower access panel, remove two screws from bottom edge of lower access panel, *Figure 22*.
- Gently lower the access panel to disengage guide lugs from bottom edge of front panel.
- Remove two screws holding bottom tabs on front panel to dryer side panels, *Figure 22*. Swing bottom of front panel away from dryer far enough to disengage hold-down clips and guide lugs from cabinet top.
- Disconnect wires from door switch, *Figure 21*.

NOTE: Refer to appropriate wiring diagram when rewiring switch.

- Disconnect wires to cylinder light (if applicable).
- Disconnect wires from moisture sensor (if applicable).
- Disengage belt from motor and idler pulleys, *Figure 30*.
- Remove four screws holding bulkhead to front flange of cabinet and lift complete bulkhead assembly out of slots in cabinet, *Figure 37*.

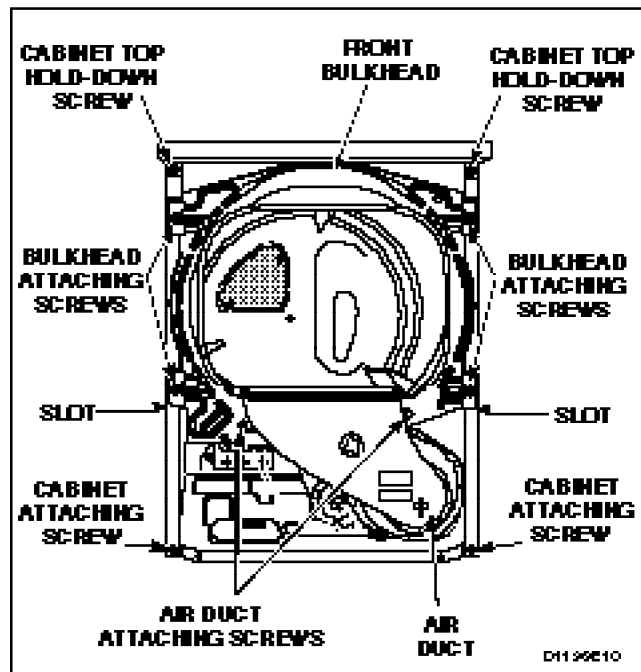

Figure 37

a **WARNING**

To reduce the risk of serious injury or death by carbon monoxide and other gases in gas dryers, carefully read and follow all instructions given in this section.

W005

IMPORTANT: When reassembling, be sure felt seal on exhaust fan cover makes airtight seal on flange of duct, *Figure 27*. If the seal is installed improperly, the airflow through the exhaust system will be restricted which can adversely affect dryer performance.

- Cylinder Glides and Glide Bracket** (Refer to *Figure 38*.)
 - Unsnap glide from each glide bracket.
 - Remove two screws holding glide bracket to front bulkhead.

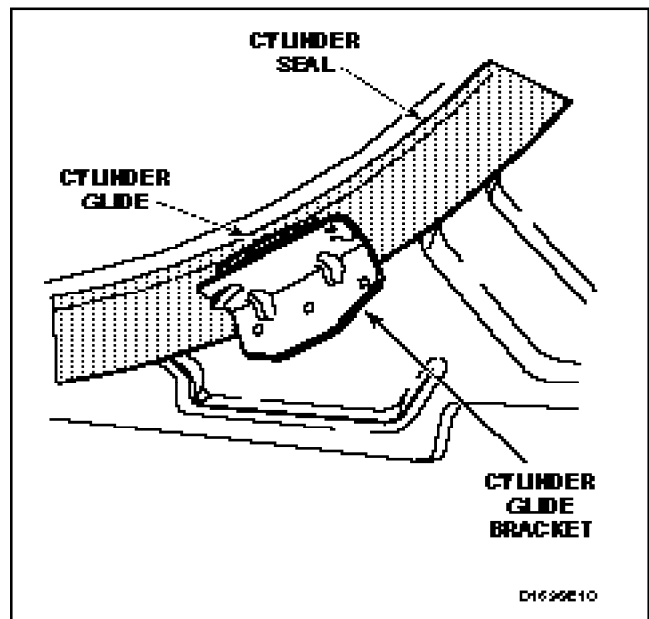

Figure 38

a **WARNING**

To reduce the risk of electric shock, fire, explosion, serious injury or death:

- Disconnect electric power to the dryer before servicing.
- Close gas shut-off valve to gas dryer before servicing.
- Never start the dryer with any guards/panels removed.
- Whenever ground wires are removed during servicing, these ground wires must be reconnected to ensure that the dryer is properly grounded.

W001

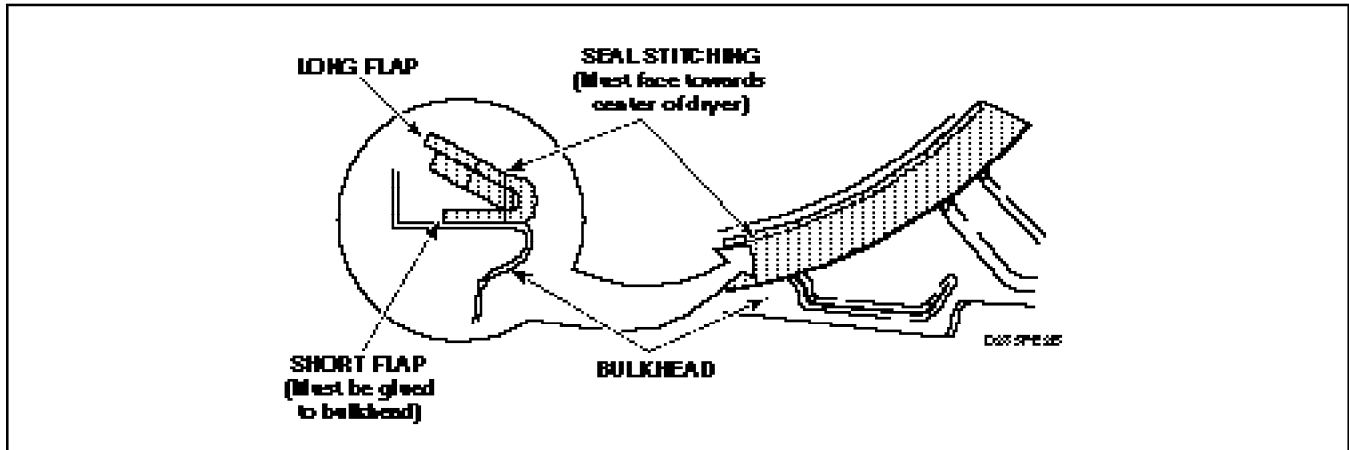

Figure 39

j. **Front Cylinder Seal** (Figure 39)

When installing the cylinder seal, it is important to remember these two important steps:

- (1) The stitching on the seal must face towards the dryer center, *Figure 39*.
- (2) The short flap, *Figure 39*, must be glued to the bulkhead and the long flap left loose.

IMPORTANT: The replacement seal can be adhered to the bulkhead using No. 22506P Sealant. This is accomplished by applying a bead of sealant around the entire flanged area where the felt seal contacts the bulkhead.

35. MOISTURE SENSOR

- a. While supporting the lower access panel, remove two screws from bottom edge of lower access panel, *Figure 22*.
- b. Gently lower the access panel to disengage guide lugs from bottom edge of front panel.
- c. Remove two screws holding bottom tabs on front panel to dryer side panels, *Figure 22*. Swing bottom of front panel away from dryer far enough to disengage hold-down clips and guide lugs from cabinet top.
- d. Disconnect wires from door switch, *Figure 21*.
- e. Open loading door, remove lint filter screws and lift lint filter out of bulkhead, *Figure 9*.

a **WARNING**

When installing lint filter, be sure to install the filter with the word "FRONT" facing the front of the dryer. If filter is installed backwards, lint will accumulate in exhaust system, causing fire and machine malfunction.

- f. Remove two screws holding duct to front bulkhead and remove air duct, *Figure 37*

a **WARNING**

To reduce the risk of serious injury or death by carbon monoxide and other gases in gas dryers, carefully read and follow all instructions given in this section.

W005

IMPORTANT: When reassembling, be sure felt seal on exhaust fan cover makes airtight seal on flange of duct, *Figure 27*. If the seal is installed improperly, the airflow through the exhaust system will be restricted which can adversely affect dryer performance.

- g. Disconnect two wires connected to the moisture sensor, *Figure 40*.
- h. Using a pliers, pinch in the locking tabs on the moisture sensor bar and push the sensor bars out of the mounting bracket.
- i. Remove the screw (located inside lower front bulkhead) holding moisture sensor mounting bracket to bulkhead, *Figure 40*.

NOTE: For test procedures, refer to SECTION VIII.

a WARNING

To reduce the risk of electric shock, fire, explosion, serious injury or death:

- Disconnect electric power to the dryer before servicing.
- Close gas shut-off valve to gas dryer before servicing.
- Never start the dryer with any guards/panels removed.
- Whenever ground wires are removed during servicing, these ground wires must be reconnected to ensure that the dryer is properly grounded.

W001

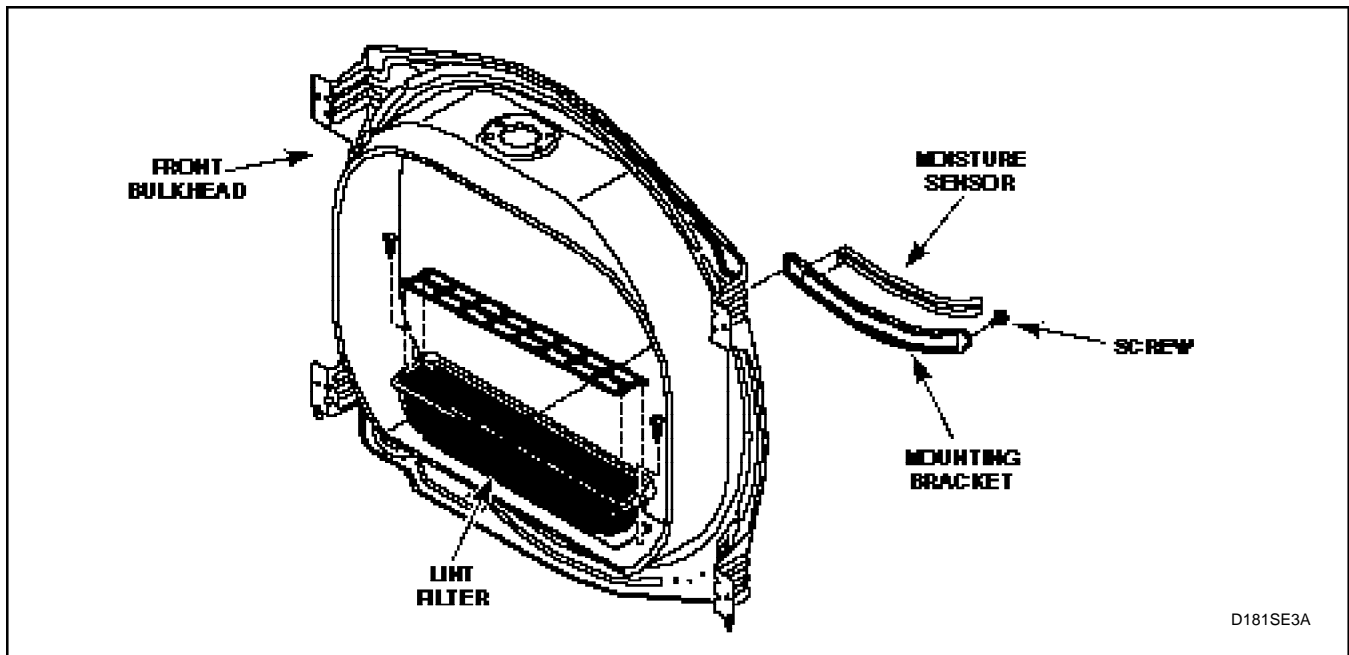

Figure 40

36. CYLINDER BELT

- While supporting the lower access panel, remove two screws from bottom edge of lower access panel, *Figure 22*.
- Gently lower the access panel to disengage guide lugs from bottom edge of front panel.
- Remove two screws holding bottom tabs on front panel to dryer side panels, *Figure 22*. Swing bottom of front panel away from dryer far enough to disengage hold-down clips and guide lugs from cabinet top.
- Disconnect wires from door switch, *Figure 21*.

NOTE: Refer to appropriate wiring diagram when rewiring switch.

- Disengage belt from motor and idler pulleys, *Figure 30*.
- Remove four screws holding bulkhead to front flange of cabinet. Then, lift complete bulkhead assembly out of slots in cabinet, *Figure 37*.

a WARNING

To reduce the risk of serious injury or death by carbon monoxide and other gases in gas dryers, carefully read and follow all instructions given in this section.

W005

IMPORTANT: When reassembling, be sure felt seal on exhaust fan cover makes airtight seal on flange of duct, *Figure 27*. If the seal is installed improperly, the airflow through the exhaust system will be restricted which can adversely affect dryer performance.

- While supporting cylinder, carefully remove belt off cylinder.

NOTE: When installing belt, be sure belt is properly installed on motor and idler pulleys, and is on the correct side of the idler lever, *Figure 30*. Belt must be positioned around cylinder between center and rear baffle screws with the ribbed surface against the cylinder. After installing belt, manually rotate cylinder counterclockwise to check that belt is properly aligned.

a **WARNING**

To reduce the risk of electric shock, fire, explosion, serious injury or death:

- Disconnect electric power to the dryer before servicing.
- Close gas shut-off valve to gas dryer before servicing.
- Never start the dryer with any guards/panels removed.
- Whenever ground wires are removed during servicing, these ground wires must be reconnected to ensure that the dryer is properly grounded.

W001

37. CYLINDER ASSEMBLY

- While supporting the lower access panel, remove two screws from bottom edge of lower access panel, *Figure 22*.
- Gently lower the access panel to disengage guide lugs from bottom edge of front panel.
- Remove two screws holding bottom tabs on front panel to dryer side panels, *Figure 22*. Swing bottom of front panel away from dryer far enough to disengage hold-down clips and guide lugs from cabinet top.
- Disconnect wires from door switch, *Figure 21*.

NOTE: Refer to appropriate wiring diagram when rewiring switch.

- Disengage belt from motor and idler pulleys, *Figure 30*.

NOTE: When reinstalling belt, be sure belt is properly installed on motor and idler pulleys, and is on the correct side of the idler lever, *Figure 30*. Belt must be positioned around cylinder between center and rear baffle screws with the ribbed surface against the cylinder. After installing belt, manually rotate cylinder counterclockwise to check that belt is properly aligned.

- Remove four screws holding bulkhead to front flange of cabinet. Then lift complete bulkhead assembly out of slots in cabinet, *Figure 37*.

a **WARNING**

To reduce the risk of serious injury or death by carbon monoxide and other gases in gas dryers, carefully read and follow all instructions given in this section.

W005

IMPORTANT: When reassembling, be sure felt seal on exhaust fan cover makes airtight seal on flange of duct, *Figure 27*. If the seal is installed improperly, the airflow through the exhaust system will be restricted which can adversely affect dryer performance.

- Loosen two cabinet top hold-down screws, *Figure 37*.
- Manually rotate cylinder until one of the baffles is at the 6 o'clock position and carefully remove cylinder out through front of dryer.
- Baffles - Remove screws holding baffles to cylinder, *Figure 41*

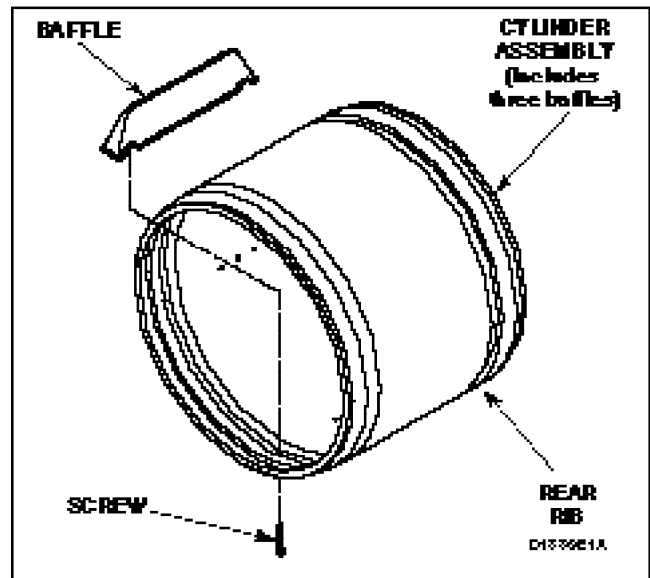

Figure 41

a **WARNING**

To reduce the risk of electric shock, fire, explosion, serious injury or death:

- Disconnect electric power to the dryer before servicing.
- Close gas shut-off valve to gas dryer before servicing.
- Never start the dryer with any guards/panels removed.
- Whenever ground wires are removed during servicing, these ground wires must be reconnected to ensure that the dryer is properly grounded.

W001

38. REAR SEAL

- a. While supporting the lower access panel, remove two screws from bottom edge of lower access panel, *Figure 22*.
- b. Gently lower the access panel to disengage guide lugs from bottom edge of front panel.
- c. Remove two screws holding bottom tabs on front panel to dryer side panels, *Figure 22*. Swing bottom of front panel away from dryer far enough to disengage hold-down clips and guide lugs from cabinet top.
- d. Disconnect wires from door switch, *Figure 21*.

NOTE: Refer to appropriate wiring diagram when rewiring switch.

- e. Remove two cabinet top hold-down screws, *Figure 35*.
- f. Lift cabinet top to a vertical position by hinging it on the rear hold-down hinges, *Figure 35*.

NOTE: Cabinet top may be raised and hinged on the rear hold-down hinges, or supported against a wall behind the dryer.

- g. Disengage belt from motor and idler pulleys, *Figure 31*.

NOTE: When reinstalling belt, be sure belt is properly installed on motor and idler pulleys and is on the correct side of the idler lever, *Figure 30*. Belt must be positioned between center and rear baffle screws with the ribbed surface against the cylinder. After installing belt, manually rotate cylinder counterclockwise to check that belt is properly aligned.

- h. Remove four screws holding bulkhead to front flange of cabinet. Then, lift complete bulkhead assembly out of slots in cabinet, *Figure 37*.

a **WARNING**

To reduce the risk of serious injury or death by carbon monoxide and other gases in gas dryers, carefully read and follow all instructions given in this section.

W005

IMPORTANT: When reassembling, be sure felt seal on exhaust fan cover makes airtight seal on flange of duct, *Figure 27*. If the seal is installed improperly, the airflow through the exhaust system will be restricted which can adversely affect dryer performance.

- i. Manually rotate cylinder until one of the baffles is at the 6 o'clock position and carefully remove cylinder out through front of dryer.
- j. Pull rear cylinder seal from flanged edge of bulkhead, *Figure 42*.

NOTE: When installing the cylinder seal, it is important to remember these two important steps:

- (1) The stitching on the seal must face towards the dryer center, *Figure 39*.
- (2) The short flap, *Figure 39*, must be glued to the bulkhead and the long flap left loose.

IMPORTANT: The seal can be adhered to the bulkhead using replacement sealant No. 22506P. This is accomplished by applying a bead of sealant around the entire flanged area where the felt seal contacts the bulkhead.

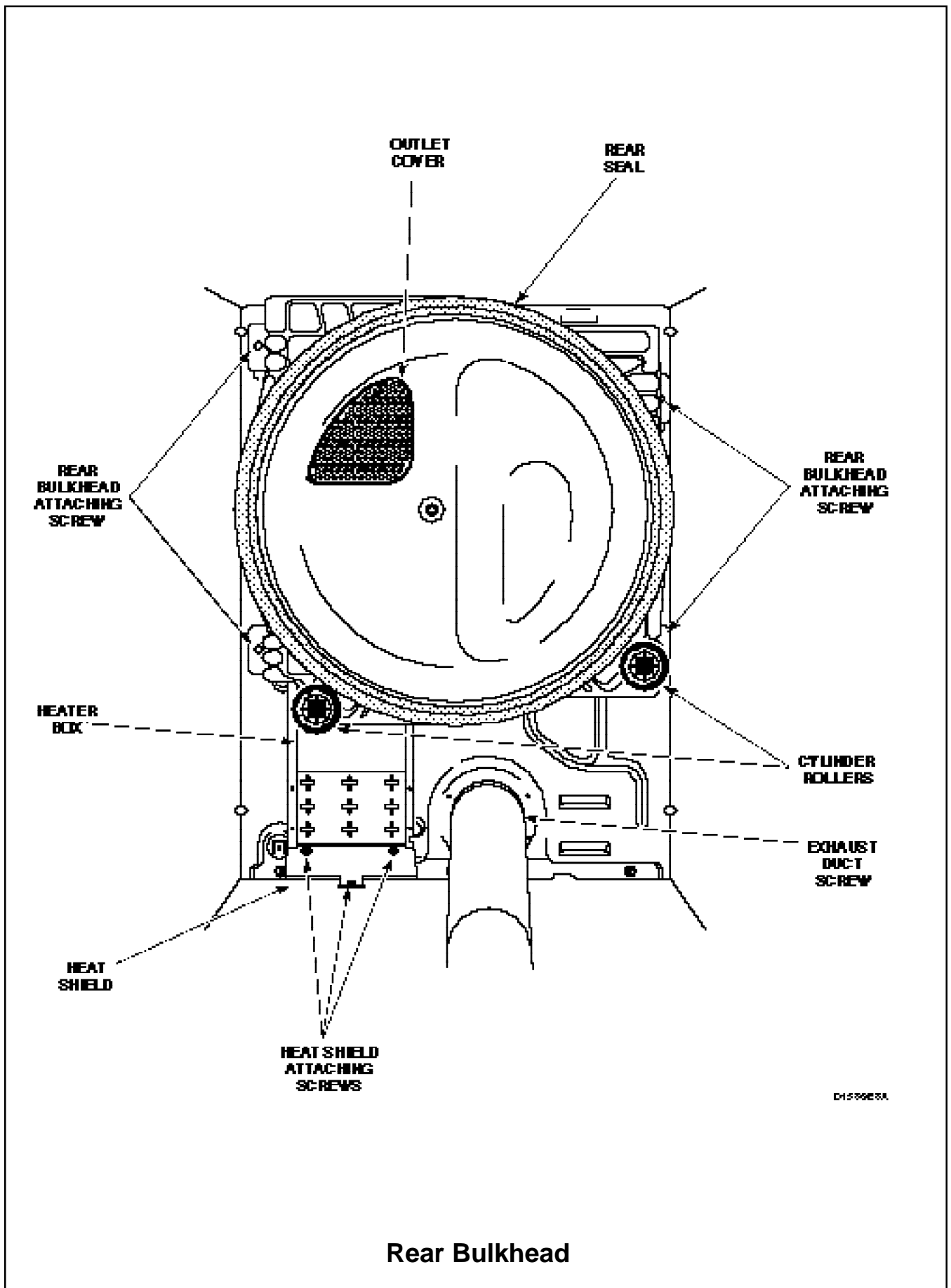

D153923A

Figure 42

a **WARNING**

To reduce the risk of electric shock, fire, explosion, serious injury or death:

- Disconnect electric power to the dryer before servicing.
- Close gas shut-off valve to the dryer before servicing.
- Never start the dryer with any guards/panels removed.
- Whenever ground wires are removed during servicing, these ground wires must be reconnected to ensure that the dryer is properly grounded.

W001

39. CYLINDER ROLLERS

- While supporting the lower access panel, remove two screws from bottom edge of lower access panel, *Figure 22*.
- Gently lower the access panel to disengage guide lugs from bottom edge of front panel.
- Remove two screws holding bottom tabs on front panel to dryer side panels, *Figure 22*. Swing bottom of front panel away from dryer far enough to disengage hold-down clips and guide lugs from cabinet top.
- Disconnect wires from door switch, *Figure 21*.

NOTE: Refer to appropriate wiring diagram when rewiring switch.

- Disengage belt from motor and idler pulleys, *Figure 30*.
- Remove four screws holding bulkhead to front flange of cabinet. Then lift complete bulkhead assembly out of slots in cabinet, *Figure 37*.

a **WARNING**

To reduce the risk of serious injury or death by carbon monoxide and other gases in gas dryers, carefully read and follow all instructions given in this section.

W005

IMPORTANT: When reassembling, be sure felt seal on exhaust fan cover makes airtight seal on flange of duct, *Figure 27*. If the seal is installed improperly, the airflow through the exhaust system will be restricted which can adversely affect dryer performance.

- Pull cylinder forward allowing rear of cylinder to drop down exposing rollers, *Figure 43*.
- Refer to *Figure 43* for removal of roller from bulkhead.

NOTE: When replacing the cylinder roller, it is important that cylinder roller is installed with the flanged surface of the roller bearing facing towards the front of the dryer.

46. OUTLET COVER

NOTE: Outlet Cover is not removable from the Heater Box Assembly that originally came with the dryer. It is only removable from the replacement Heater Box Assembly, Part No. 500179P.

- Open door and remove two screws holding outlet cover to rear bulkhead, *Figure 42*. (If present)

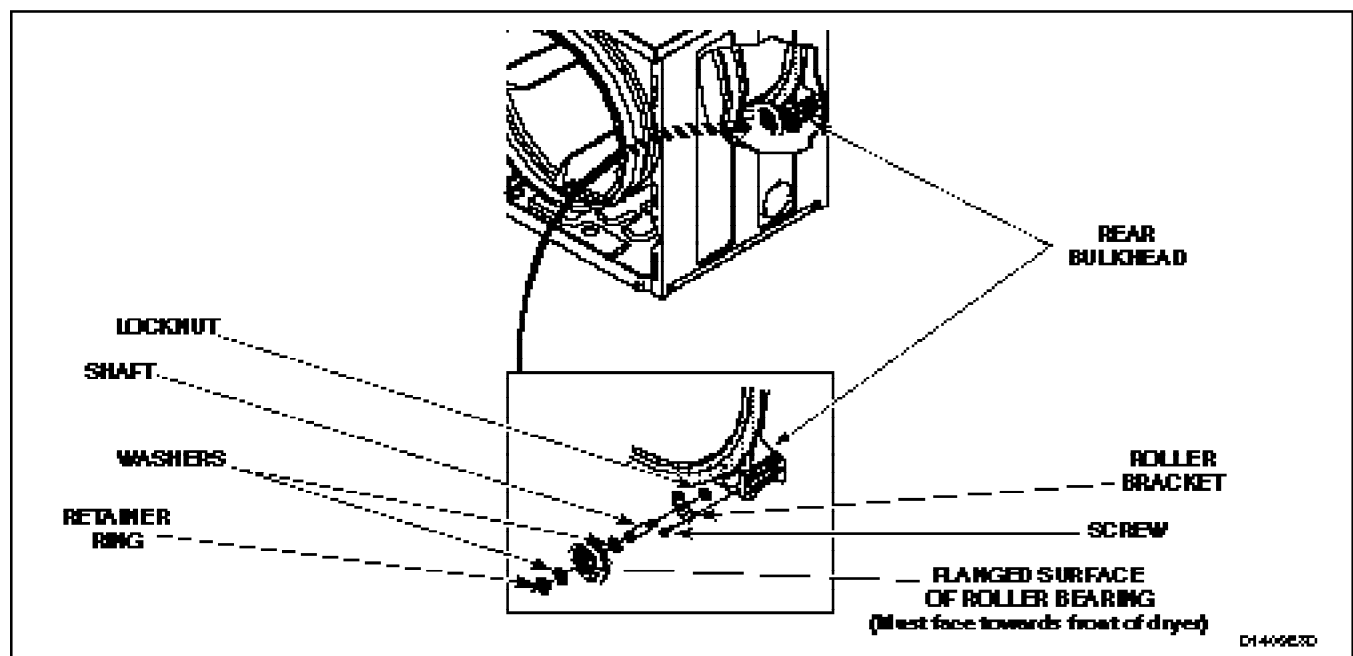

Figure 43

a WARNING

To reduce the risk of electric shock, fire, explosion, serious injury or death:

- Disconnect electric power to the dryer before servicing.
- Close gas shut-off valve to gas dryer before servicing.
- Never start the dryer with any guards/panels removed.
- Whenever ground wires are removed during servicing, these ground wires must be reconnected to ensure that the dryer is properly grounded.

W001

41. REAR BULKHEAD AND HEATER BOX

- While supporting the lower access panel, remove two screws from bottom edge of lower access panel, *Figure 22*.
- Gently lower the access panel to disengage guide lugs from bottom edge of front panel.
- Remove two screws from bottom tabs on front panel to dryer side panels, *Figure 22*. Swing bottom of front panel away from dryer far enough to disengage hold-down clips and guide lugs from cabinet top.
- Disconnect wires from door switch, *Figure 21*.

NOTE: Refer to appropriate wiring diagram when rewiring switch.

- Disengage belt from motor and idler pulleys, *Figure 30*.

NOTE: When reinstalling belt, be sure belt is properly installed on motor and idler pulleys and is on the correct side of the idler lever, *Figure 30*. Belt must be positioned around cylinder between center and rear baffle screws with the ribbed surface against the cylinder. After installing belt, manually rotate cylinder counterclockwise to check that belt is properly aligned.

- Remove four screws holding bulkhead to front flange of cabinet. Then lift complete bulkhead assembly out of slots in cabinet, *Figure 37*.

a WARNING

To reduce the risk of serious injury or death by carbon monoxide and other gases in gas dryers, carefully read and follow all instructions given in this section.

W005

IMPORTANT: When reassembling, be sure felt seal on exhaust fan cover makes airtight seal on flange of duct, *Figure 27*. If the seal is installed improperly, the airflow through the exhaust system will be restricted which can adversely affect dryer performance.

- Loosen two cabinet top hold-down screws, *Figure 35*.
- Manually rotate cylinder until one of the baffles is at the 6 o'clock position and carefully remove cylinder out through front of dryer.
- Gas Models:**
 - Disconnect igniter wires at disconnect blocks, sensor wires from flame sensor terminals, and wires from gas valve coils at the quick disconnect blocks, *Figure 24*.
 - Remove screw from right side of burner housing, while holding burner tube in place, *Figure 26*.
 - Gently move burner tube toward rear of dryer to disengage tab from slot on left side of burner housing, *Figure 24*.
 - Carefully rotate burner tube and igniter counterclockwise so tab is at 8 o'clock position.
 - Move air shutter end of burner tube slightly to right and CAREFULLY remove burner tube and igniter assembly out through front of dryer.

IMPORTANT: The igniter is very fragile. Be careful not to damage it during removal.

- Remove screw holding burner housing to heat shroud, *Figure 24*.
- Remove screw holding front of burner housing to dryer base and remove housing out through front of dryer, *Figure 26*.
- Remove four screws holding shroud to heater box, *Figure 24*, and remove shroud out through front of dryer.
- Electric Models:**
 - Remove two screws holding element and plate to heater box, then pull element down and away from heater box, *Figure 26*.
- Remove screw holding heat shield to dryer base, *Figure 42*.
- While supporting bulkhead, remove the four screws holding rear bulkhead to dryer cabinet, *Figure 42*, then lift complete assembly out of dryer.
- To remove heat shield from heater box, remove two screws holding heat shield to heater box, *Figure 42*.
- To remove heater box from rear bulkhead, refer to *Figure 44*.

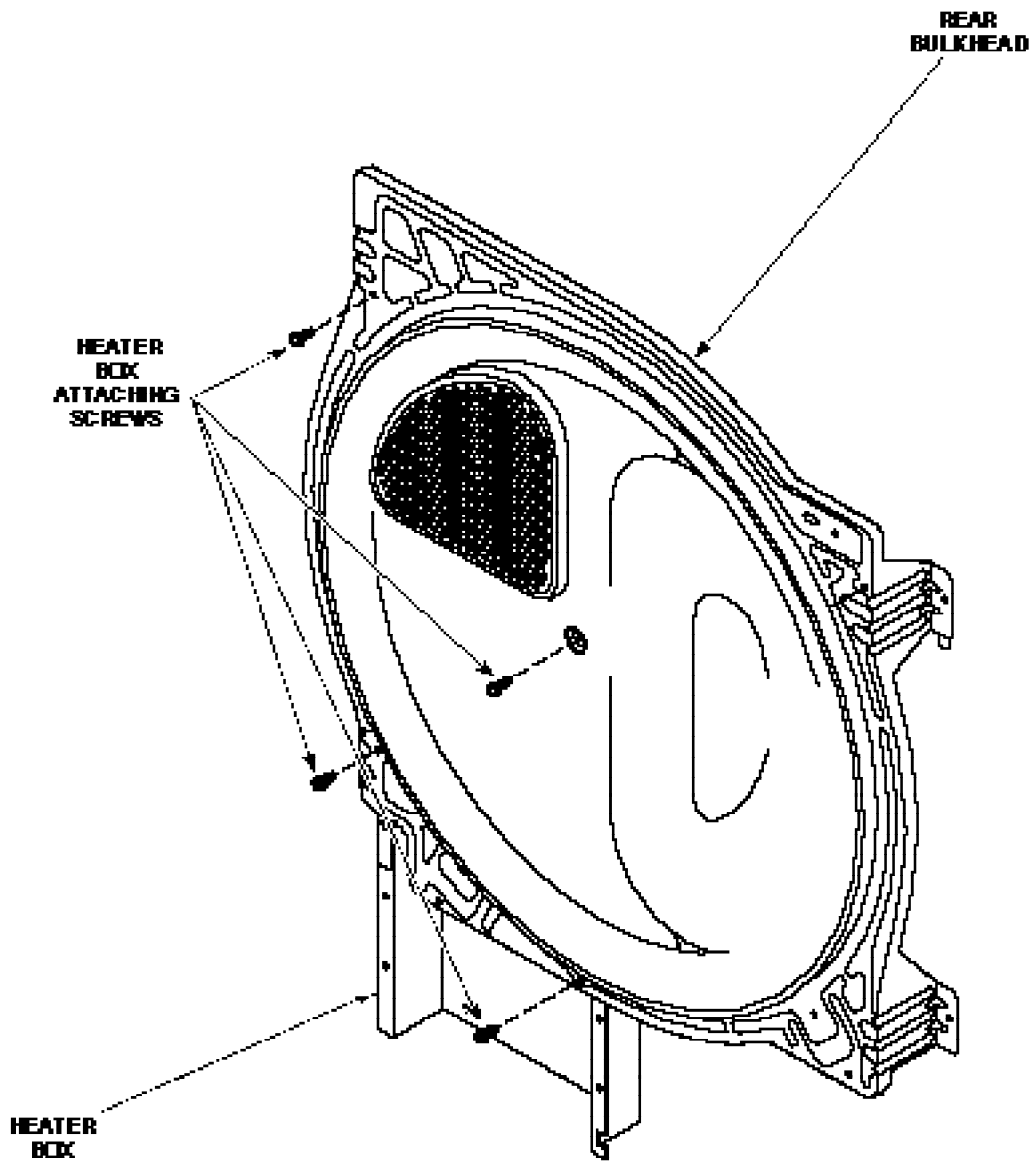

D1416235

Rear Bulkhead

Figure 44

a **WARNING**

To reduce the risk of electric shock, fire, explosion, serious injury or death:

- Disconnect electric power to the dryer before servicing.
- Close gas shut-off valve to gas dryer before servicing.
- Never start the dryer with any guards/panels removed.
- Whenever ground wires are removed during servicing, these ground wires must be reconnected to ensure that the dryer is properly grounded.

W001

42. TERMINAL BLOCK OR POWER CORD

a. **Terminal Block:**

- (1) While supporting the lower access panel, remove two screws from bottom edge of lower access panel, *Figure 22*.
- (2) Gently lower the access panel to disengage guide lugs from bottom edge of front panel.
- (3) Remove two screws holding bottom tabs on front panel to dryer side panels, *Figure 22*. Swing bottom of front panel away from dryer far enough to disengage hold-down clips and guide lugs from cabinet top.
- (4) Disconnect wires from door switch, *Figure 21*.

NOTE: Refer to appropriate wiring diagram when rewiring switch.

- (5) Remove two cabinet hold-down screws, *Figure 35*.

- (6) Lift cabinet top to a vertical position by hinging it on the rear hold-down brackets, *Figure 35*.

NOTE: When servicing, cabinet top may be raised and hinged on the rear hold-down brackets, or supported against wall behind the dryer.

- (7) Remove all wires from terminal block. (Refer to appropriate wiring diagram when rewiring terminal block).
- (8) Remove screw holding terminal block to rear bulkhead, *Figure 45*.

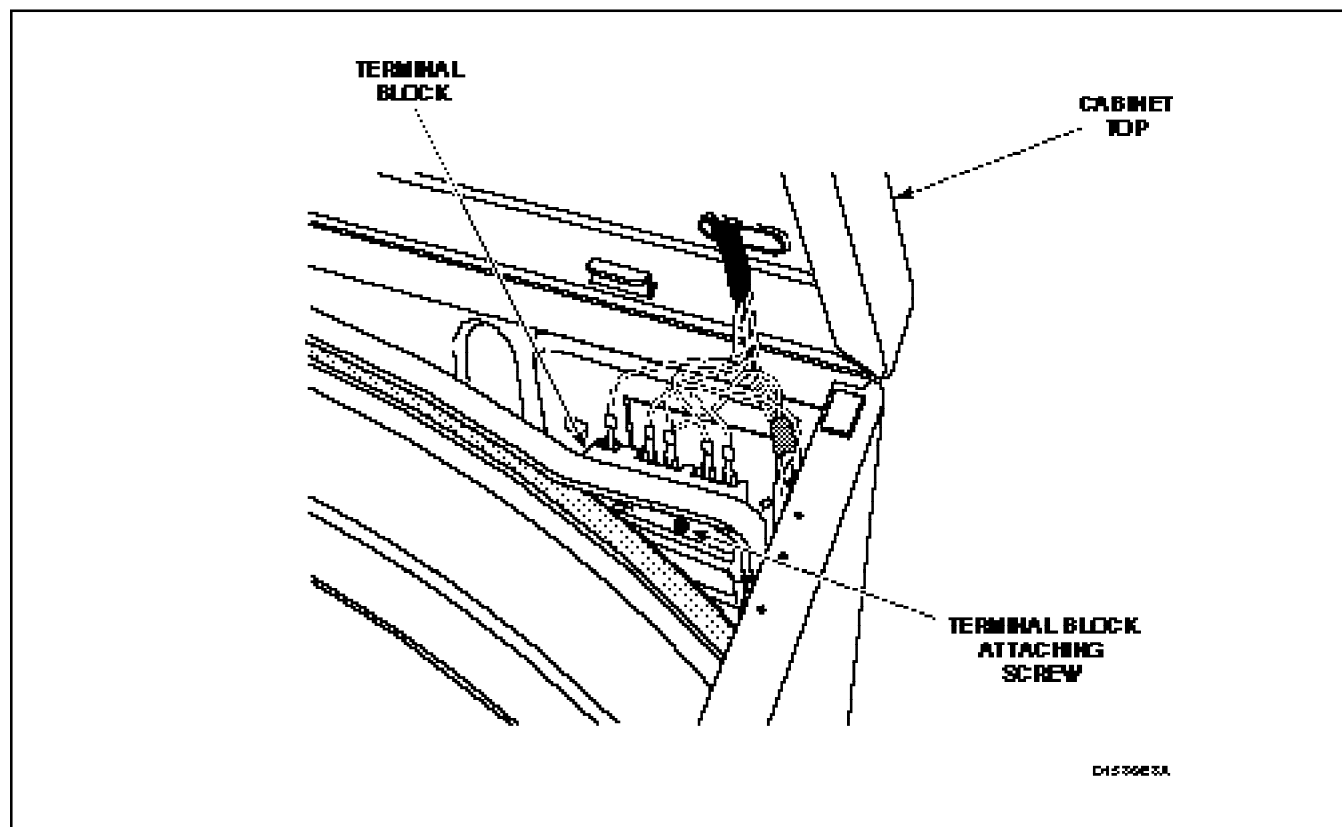

Figure 45

a **WARNING**

To reduce the risk of electric shock, fire, explosion, serious injury or death:

- Disconnect electric power to the dryer before servicing.
- Close gas shut-off valve to gas dryer before servicing.
- Never start the dryer with any guards/panels removed.
- Whenever ground wires are removed during servicing, these ground wires must be reconnected to ensure that the dryer is properly grounded.

W001

b. **Power Cord:**

- (1) Remove access plate on rear of cabinet.
- (2) Remove strain relief.
- (3) Remove screw holding power cord ground wire to rear bulkhead, *Figure 46*.

NOTE: Reinstall screw and ground wires into same hole in bulkhead when reinstalling power cord.

- (4) Disconnect mox plug and remove power cord from rear of dryer cabinet.

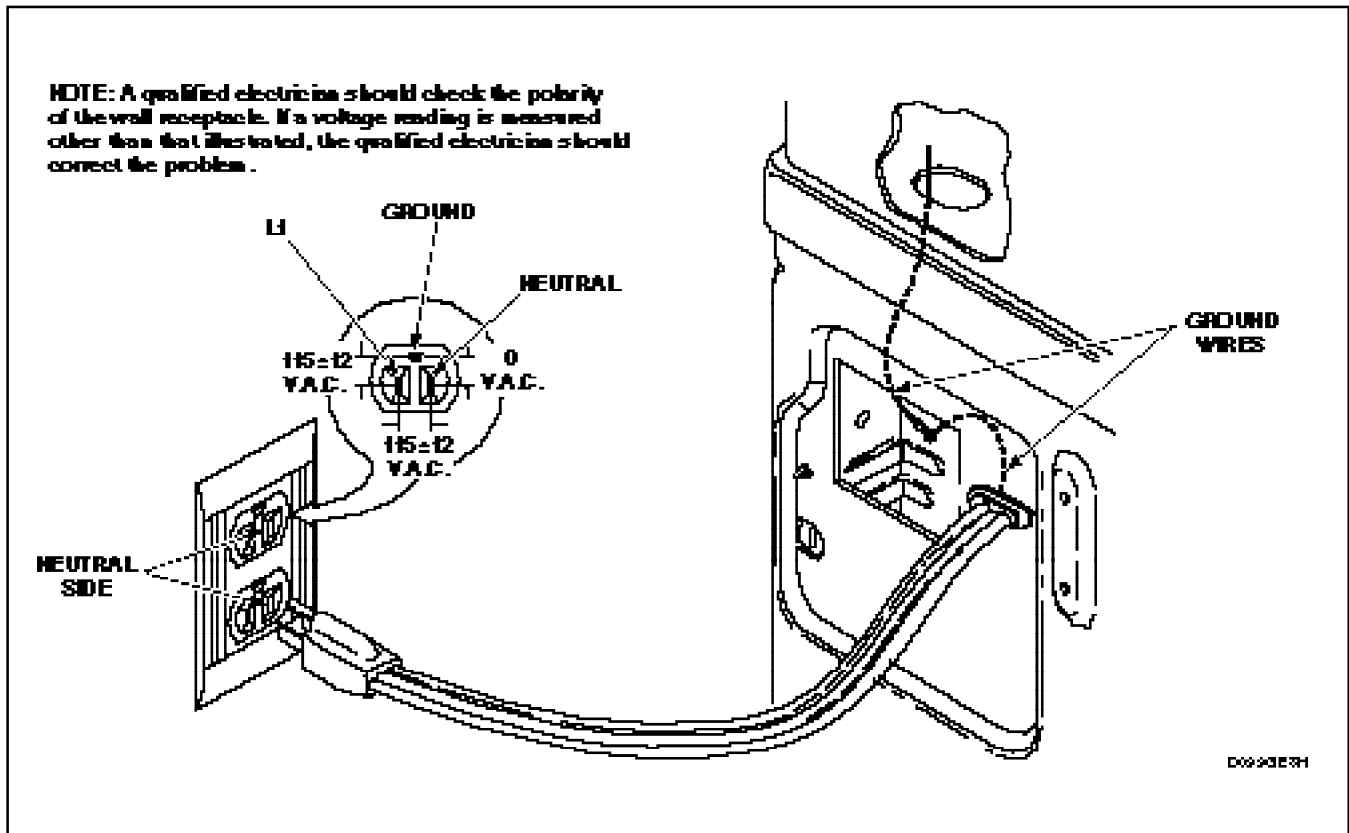

Figure 46

a WARNING

To reduce the risk of electric shock, fire, explosion, serious injury or death:

- Disconnect electric power to the dryer before servicing.
- Close gas shut-off valve to gas dryer before servicing.
- Never start the dryer with any guards/panels removed.
- Whenever ground wires are removed during servicing, these ground wires must be reconnected to ensure that the dryer is properly grounded.

W001

43. TERMINAL BLOCK TERMINALS

Remove terminals from the plastic connector block using No. 283P4 Terminal Extractor Tool as follows:

- a. Insert the tool into the plastic connector block on the back of the terminal being removed, *Figure 34*.
- b. Apply tool pressure to compress the terminal locking tab on terminal and force the terminal out back side of plastic connector block, *Figure 34*.

To install terminal in plastic connector block, insert terminal (with wire securely crimped in place) into back side of plastic connector block. Push terminal into plastic connector block until locking tab on terminal spreads and holds terminal in place.

44. CABINET

- a. Remove the three screws holding the control assembly to the control hood rear panel, *Figures 5, 6, 7 and 8*.
- b. Rotate the assembly forward to access inner wiring.
- c. Disconnect wiring from inner components and carefully remove components from control hood assembly.

NOTE: Refer to appropriate wiring diagram when rewiring component parts.

- d. Rotate control hood assembly forward and lift to free assembly from hold-down clips.
- e. Remove two screws from bottom edge of lower front access panel, *Figure 22*.
- f. Swing bottom of panel away from dryer to disengage hold-down clips and guide lugs from bottom edge of front panel.

- g. Remove two screws holding bottom tabs on front panel to dryer side panels, *Figure 22*. Swing bottom of front panel away from dryer far enough to disengage hold-down clips and guide lugs from cabinet top.
- h. Disconnect wires from door switch, *Figure 21*.

NOTE: Refer to appropriate wiring diagram when rewiring switch.

- i. Remove two cabinet top hold-down screws, *Figure 35*.
- j. Lift cabinet top to a vertical position by hinging it on the rear hold-down brackets, *Figure 35*.

NOTE: Cabinet top may be raised and hinged on the rear hold-down hinges or supported against wall behind dryer while servicing.

- k. Carefully withdraw wire harness through hole in cabinet top and lift the top off the hold-down hinges with timer case attached, *Figure 35*.
- l. Disengage belt from motor and idler pulleys, *Figure 30*.

NOTE: When reinstalling belt, be sure belt is properly installed on motor and idler pulleys and is on the correct side of the idler lever, *Figure 30*. Belt must be positioned around cylinder between center and rear baffle screws with the ribbed surface against the cylinder. After installing belt, manually rotate cylinder counterclockwise to check that belt is properly aligned.

- m. Remove four screws holding bulkhead to front flange of cabinet and lift complete bulkhead assembly out of slots in cabinet, *Figure 37*.
- n. Manually rotate cylinder until one of the baffles is at the 6 o'clock position and carefully remove cylinder out through front of dryer.

a WARNING

To reduce the risk of electric shock, fire, explosion, serious injury or death:

- Disconnect electric power to the dryer before servicing.
- Close gas shut-off valve to gas dryer before servicing.
- Never start the dryer with any guards/panels removed.
- Whenever ground wires are removed during servicing, these ground wires must be reconnected to ensure that the dryer is properly grounded.

W001

o. Gas Models:

- (1) Disconnect igniter wires at disconnect blocks, sensor wires from flame sensor terminals, and wires from gas valve coils at the quick disconnect blocks, *Figure 24*.
- (2) Remove screw from right side of burner housing holding burner tube in place, *Figure 26*.
- (3) Gently move burner tube toward rear of dryer to disengage tab from slot on left side of burner housing, *Figure 24*.
- (4) Carefully rotate burner tube and igniter counterclockwise so tab is at 8 o'clock position.
- (5) Move air shutter end of burner tube slightly to right and CAREFULLY remove burner tube and igniter assembly out through front of dryer.

IMPORTANT: The igniter is very fragile. Be careful not to damage it during removal.

- (6) Remove screw holding burner housing to heat shroud, *Figure 24*.
- (7) Remove screw holding front of burner housing to dryer base and remove housing out through front of dryer, *Figure 24*.
- (8) Remove four screws holding shroud to heater box, *Figure 24*, and remove shroud out through front of dryer.

p. Electric Models:

- Remove two screws holding element and plate to heater box, then pull element down and away from heater box, *Figure 26*.
- q. Remove screw holding heat shield to dryer base, *Figure 42*.
 - r. While supporting bulkhead, remove screws holding bulkhead to rear of dryer cabinet, and remove assembly out of dryer, *Figure 42*.
 - s. Remove screw holding exhaust duct to dryer cabinet and pull duct out of cabinet, *Figure 42*.
 - t. Remove two screws from each rear cabinet top hold-down bracket, *Figure 37*.
 - u. Remove screw holding access plate and remove plate.
 - v. Remove wire harness clips.
 - w. Remove guide lugs and screws.
 - x. Remove two screws from front edge at each side of cabinet, *Figure 37*. Then remove remaining screws from around bottom of cabinet and lift cabinet off base.

a WARNING

To reduce the risk of electric shock, fire, explosion, serious injury or death:

- Disconnect electric power to the dryer before servicing.
- Close gas shut-off valve to gas dryer before servicing.
- Never start the dryer with any guards/panels removed.
- Whenever ground wires are removed during servicing, these ground wires must be reconnected to ensure that the dryer is properly grounded.

W001

45. BASE

- a. While supporting the lower access panel, remove two screws from bottom edge of lower access panel, *Figure 22*.
- b. Gently lower the access panel to disengage guide lugs from bottom edge of front panel.
- c. Remove two screws holding bottom tabs on front panel to dryer side panels, *Figure 22*. Swing bottom of front panel away from dryer far enough to disengage hold-down clips and guide lugs from cabinet top.
- d. Disconnect wires from door switch, *Figure 21*.

NOTE: Refer to appropriate wiring diagram when rewiring switch.

e. Gas Models:

- (1) Disconnect igniter wires at disconnect blocks, sensor wires from flame sensor terminals, and wires from gas valve coils at the quick disconnect blocks, *Figure 24*.
- (2) Close main gas shut-off valve and gas shut-off valve inside of dryer, *Figure 24*.
- (3) Disconnect gas line to dryer.
- (4) Remove three screws holding gas valve bracket to base and remove valve with lead-in pipe attached, *Figure 24*.
- (5) Remove screw from right side of burner housing, holding burner tube in place, *Figure 26*.
- (6) Gently move burner tube toward rear of dryer to disengage tab from slot on left side of burner housing, *Figure 24*.
- (7) Carefully rotate burner tube and igniter counterclockwise so tab is at 8 o'clock position and CAREFULLY remove burner tube and igniter assembly out through front of dryer.

IMPORTANT: The igniter is very fragile. Be careful not to damage it during removal.

- (8) Remove screw holding front of burner housing to dryer base, *Figure 26*.
- (9) Remove four screws holding shroud to heater box, *Figure 24*, and remove shroud and burner housing out through front of dryer.

f. Electric Models:

- (1) Remove two screws holding element and plate to heater box, then pull element down and away from heater box, *Figure 26*.
 - (2) Disconnect wire harness from limit thermostat, thermal fuse and/or heating element, *Figure 26*.
- g. Remove screw holding heat shield to dryer base, *Figure 44*.

- h. Remove lint filter screws and lint filter, *Figure 9*.
- i. Remove screws holding air duct to front bulkhead and remove air duct, *Figure 28*.

a WARNING

To reduce the risk of serious injury or death by carbon monoxide and other gases in gas dryers, carefully read and follow all instructions given in this section.

W005

IMPORTANT: When reassembling, be sure felt seal on exhaust fan cover makes airtight seal on flange of duct, *Figure 27*. If the seal is installed improperly, the airflow through the exhaust system will be restricted which can adversely affect dryer performance.

- j. Disconnect wires from thermostat and heater, *Figure 29*.

NOTE: Refer to appropriate wiring diagram when rewiring thermostat and heater.

- k. Remove cylinder belt from idler and motor pulleys, *Figure 30*.
- l. Remove two screws holding motor mounting bracket to dryer base. Then pull complete assembly forward to disengage middle exhaust duct.
- m. Rotate the assembly counterclockwise 90° and slide out front of machine.
- n. Disconnect wires from motor switch and remove harness clip from motor bracket, *Figure 31*. Then, set motor and exhaust assembly off to the side.
- o. Remove screw holding bracket on exhaust duct to rear of cabinet and pull duct out of cabinet, *Figure 42*.

IMPORTANT: When reinstalling motor and exhaust assembly, be sure wire harness on right side is clipped to motor mounting bracket and is routed along dryer base (between motor mounting bracket and right side of cabinet), *Figure 28*. Tab on rear of motor mounting bracket must be slid into slot in dryer base. Be sure the belt has been installed on the correct side of the idler lever, *Figure 30*.

- p. Remove two screws from front edge at each side of cabinet, *Figure 37*. Then remove remaining screws from around bottom of cabinet and lift cabinet off base.
- q. Remove leveling legs from base and reinstall on new base, *Figure 47*.

SECTION III

Adjustments

46. LEVELING LEGS (Figure 47)

NOTE: Dryer should be installed on a solid and level floor.

- a. Place dryer in position, adjust the legs until dryer is level.

a WARNING

To reduce the risk of electrical shock, fire, explosion, serious injury or death, disconnect electric power to the dryer before servicing.

NOTE: Legs can be adjusted outside the dryer by using a 1-1/4 inch size wrench, or from inside the dryer (with lower front access panel removed) by using a 1/4 inch drive ratchet with extension.

- b. Keep dryer as close to the floor as possible. All four legs must rest firmly on the floor so weight of the dryer is evenly distributed. The dryer **MUST NOT** rock.

IMPORTANT: DO NOT move the dryer at any time unless the dryer is completely assembled. **DO NOT** slide the dryer across the floor once the leveling legs have been extended as the legs and base could become damaged.

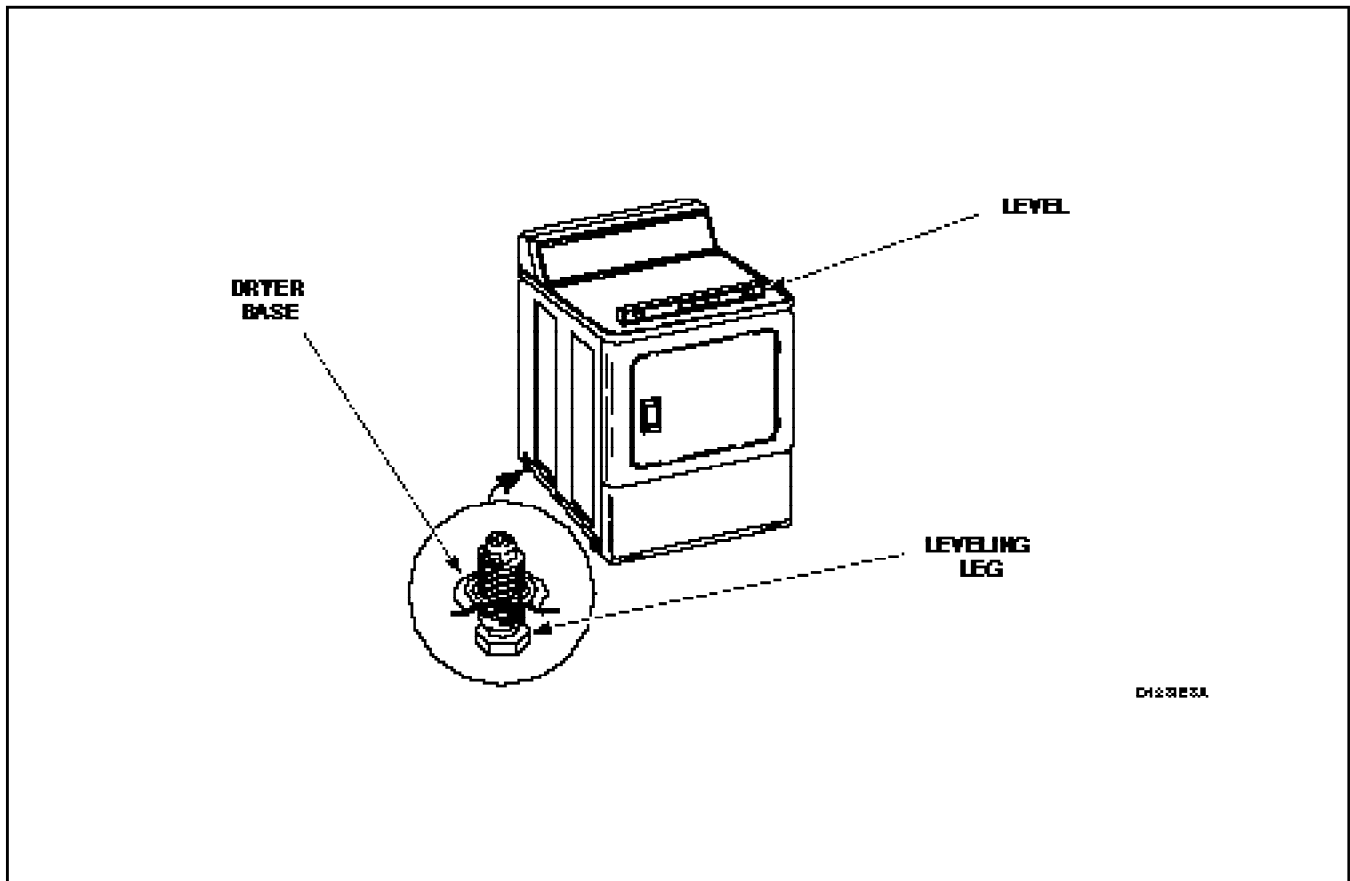

Figure 47

47. BURNER FLAME - Gas Models

- a. While supporting the lower access panel, remove two screws from bottom edge of lower access panel, *Figure 22*.
- b. Gently lower the access panel to disengage guide lugs from bottom edge of front panel.
- c. Set timer at "60" minutes.
- d. Close the loading door, start the dryer in a heat setting (refer to Operating Instructions supplied with the dryer); the dryer will start, the igniter will glow red and the main burner will ignite.
- e. Allow the dryer to operate for approximately five minutes, then loosen the air shutter lock screw, *Figure 48*.

- f. Turn the air shutter to the left to get a luminous yellow tipped flame, then turn it back slowly to the right to obtain a steady blue flame.
- g. After proper flame is obtained, tighten air shutter lock screw securely, *Figure 48*.
- h. Reinstall lower front access panel and screws.

a **WARNING**

To reduce the risk of fire or serious injury, the access door must be in place during normal operation.

After the dryer has operated for approximately three minutes, exhaust air or exhaust pipe should be warm.

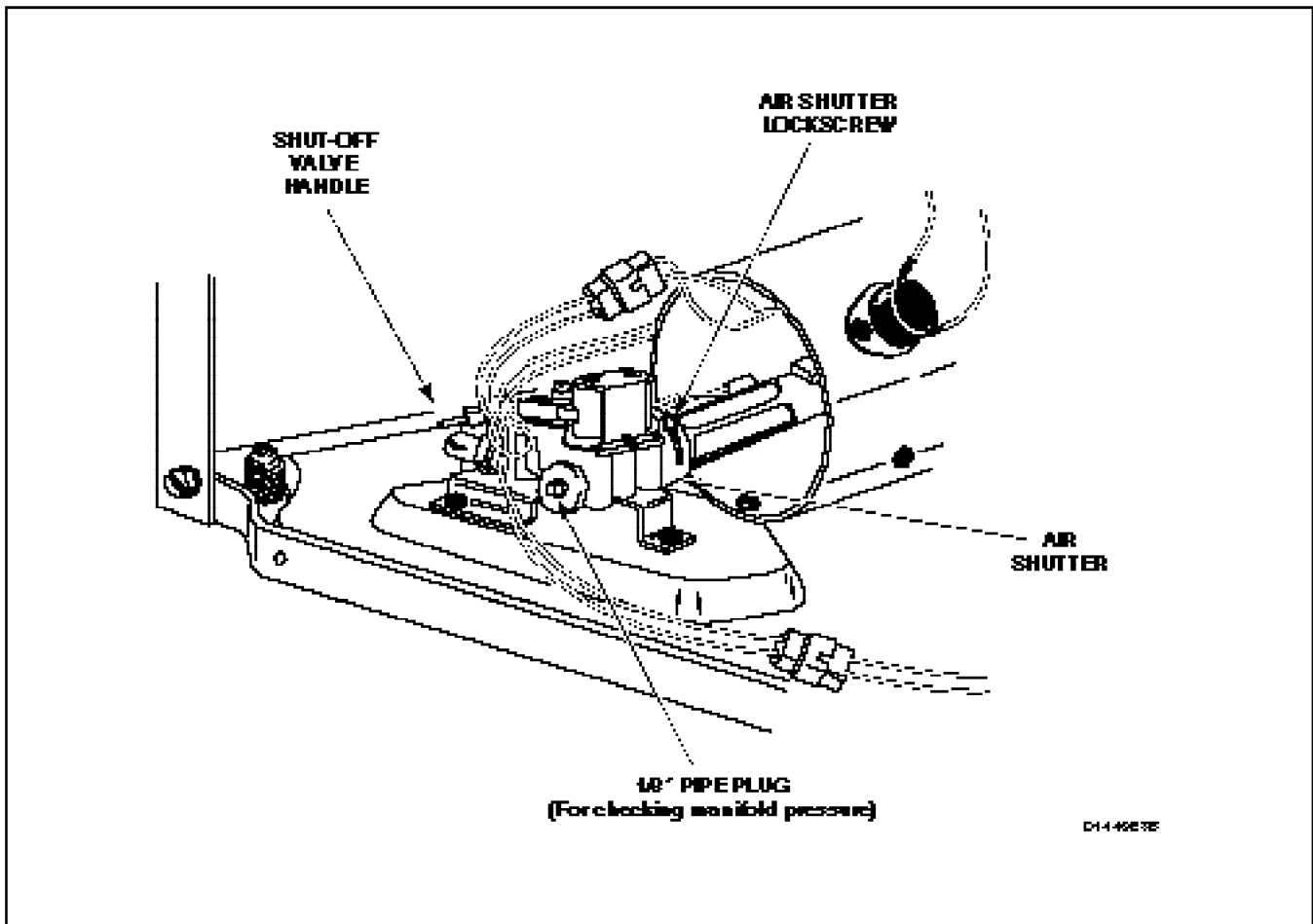

Figure 48

SECTION IV

Test Procedures

a WARNING

To reduce the risk of electric shock, fire, explosion, serious injury or death:

- Disconnect electric power to the dryer before servicing.
- Close gas shut-off valve to gas dryer before servicing.
- Never start the dryer with any guards/panels removed.
- Whenever ground wires are removed during servicing, these ground wires must be reconnected to ensure that the dryer is properly grounded.

W001

IMPORTANT: Electrical test procedures in this service manual are performed by using a Volt-Ohm meter. Tests can also be performed using a multi-meter or any other electrical testing equipment with which the service person is familiar.

48. DRIVE MOTOR (Figure 49)

- a. Remove motor and exhaust assembly, paragraph 30.
- b. Disconnect motor wire harness at motor disconnect block.

NOTE: Refer to appropriate wiring diagram when rewiring motor switch.

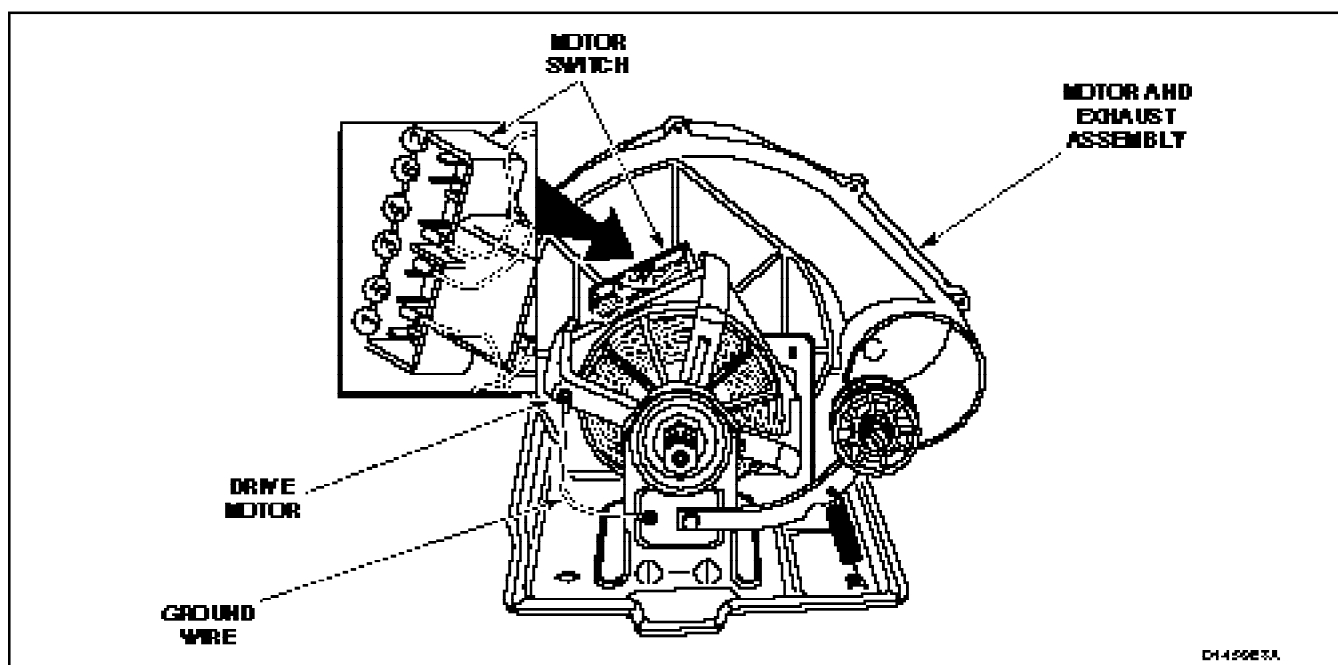

Figure 49

a WARNING

- To reduce the risk of electric shock, fire, explosion, serious injury or death:
- Disconnect electric power to the dryer before servicing.
 - Close gas shut-off valve to gas dryer before servicing.
 - Never start the dryer with any guards/panels removed.
 - Whenever ground wires are removed during servicing, these ground wires must be reconnected to ensure that the dryer is properly grounded.

W001

c. Motor Switch (Refer to SECTION VI.)

a WARNING

Disconnect electric power to dryer before performing any of the following steps or replacing inoperative motor switch.

Unplug the motor connector before starting this test.

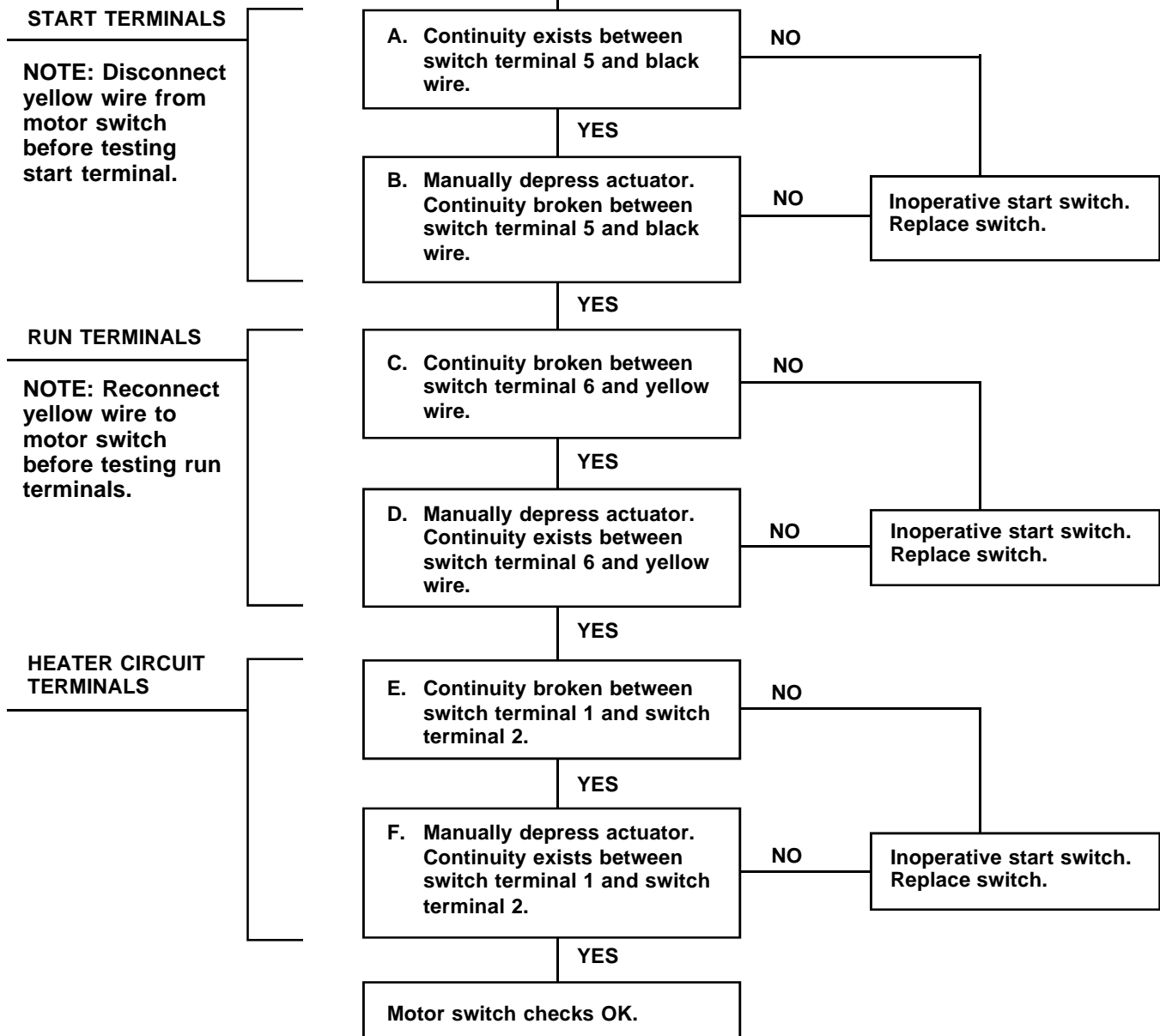

a WARNING

To reduce the risk of electric shock, fire, explosion, serious injury or death:

- Disconnect electric power to the dryer before servicing.
- Close gas shut-off valve to gas dryer before servicing.
- Never start the dryer with any guards/panels removed.
- Whenever ground wires are removed during servicing, these ground wires must be reconnected to ensure that the dryer is properly grounded.

W001

d. Motor Windings. (Refer to SECTION VI.)

a WARNING

Disconnect electric power to dryer before performing any of the following steps or replacing inoperative motor.

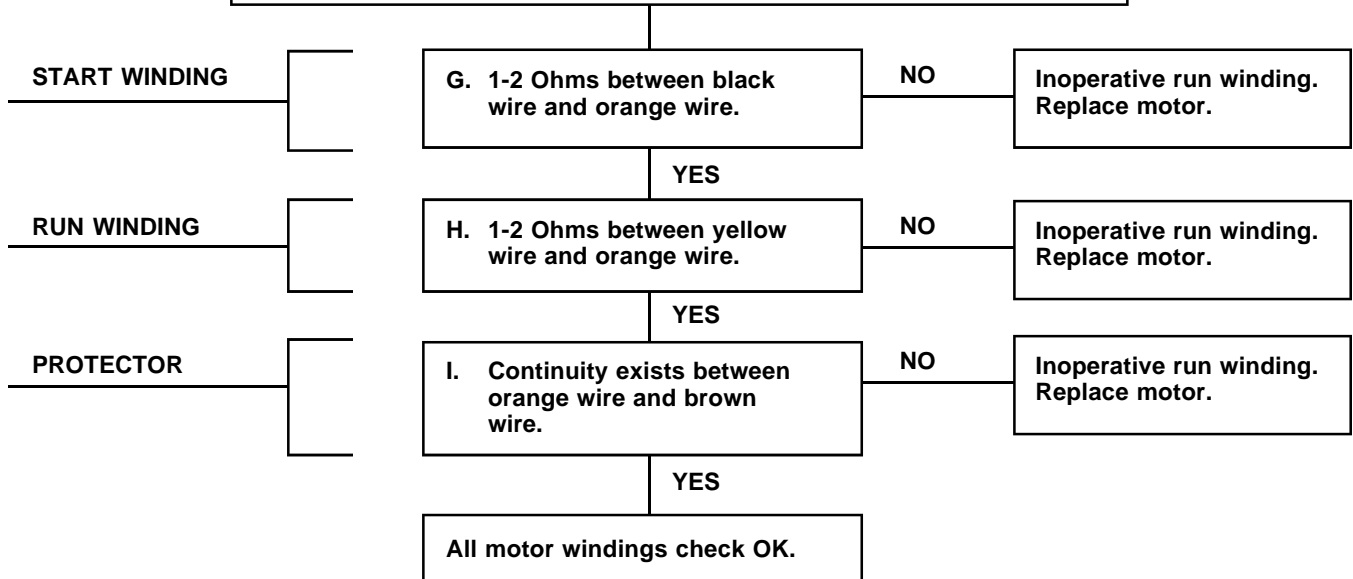

a WARNING

To reduce the risk of electric shock, fire, explosion, serious injury or death:

- Disconnect electric power to the dryer before servicing.
- Close gas shut-off valve to gas dryer before servicing.
- Never start the dryer with any guards/panels removed.
- Whenever ground wires are removed during servicing, these ground wires must be reconnected to ensure that the dryer is properly grounded.

W001

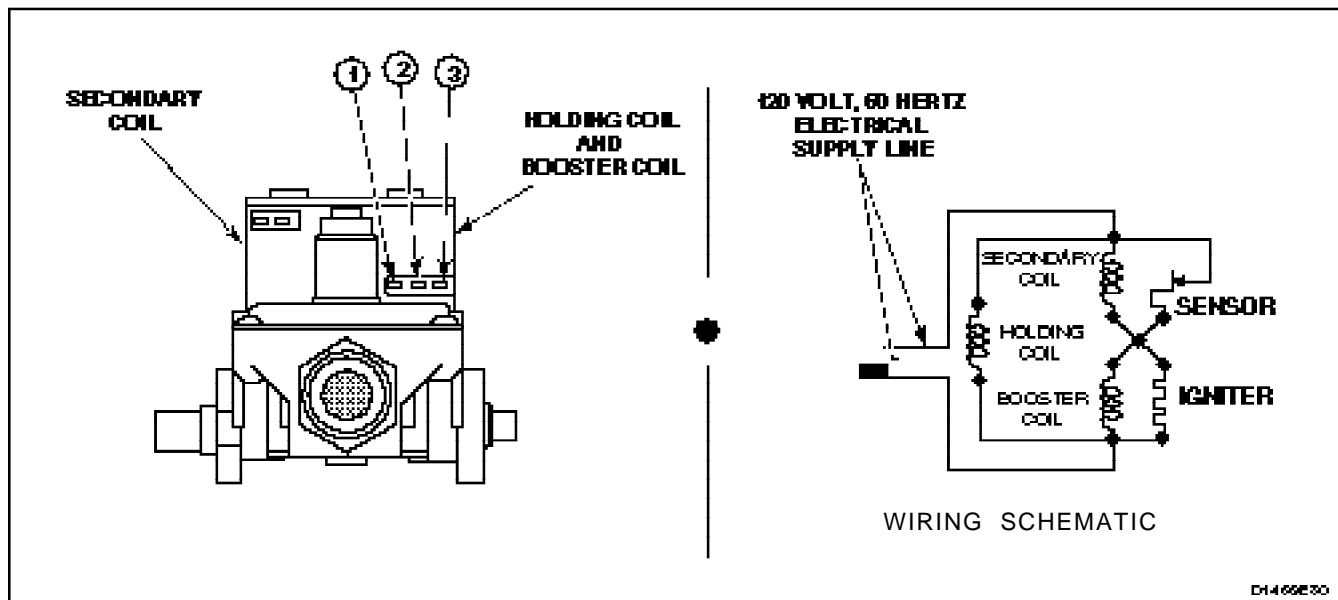

Figure 50

49. BURNER SYSTEM OPERATION (Figure 50)

Components

This burner has four basic components: A silicon carbide (glow bar) igniter, burner tube, flame sensor, and a two-stage gas valve consisting of a split-coil valve and a secondary coil valve. The split-coil valve is opened when the dryer thermostat calls for heat, while the secondary valve does not open until the igniter has attained ignition temperature.

Pre-Ignition Circuits

When the dryer thermostat calls for heat, circuits are completed through the holding coil, flame sensor, booster coil and igniter. Both coils must be energized to open split-coil valve. Once opened, the holding coil can hold the valve open without assistance from the booster coil. The current shunted around the secondary coil by the flame sensor, passes through the igniter causing it to get hot.

Burner Circuit

In approximately 30 seconds, the igniter attains ignition temperature and the flame sensor (located on burner housing beside the igniter)

contacts open. A circuit is then completed through the secondary valve coil, opening the valve and allowing gas to flow. Ignition is made and the heat from the burner flame causes the flame sensor contacts to open.

IGNITION SYSTEM FEATURES (Figure 50)

MOMENTARY POWER INTERRUPTION: Upon resumption of power, flame sensor contacts will still be open, permitting secondary valve to open. However, with the secondary coil in the circuit, the booster coil cannot draw enough current to open the split-coil valve. When flame sensor contacts do reclose, the secondary valve will close, and the burner system will be in the normal pre-ignition circuit.

FLAME FAILURE: In case of flame failure, the flame sensor contacts will reclose in about 45 seconds. This will close the secondary valve and the burner system will be in the normal pre-ignition circuit.

IGNITION FAILURE: If flame is not established as flame sensor contacts open, secondary valve will remain open until flame sensor contacts reclose. Flame sensor will continue to recycle the igniter and secondary valve (about once per minute) until ignition is made or dryer is turned off.

a **WARNING**

To reduce the risk of electric shock, fire, explosion, serious injury or death:

- Disconnect electric power to the dryer before servicing.
- Close gas shut-off valve to gas dryer before servicing.
- Never start the dryer with any guards/panels removed.
- Whenever ground wires are removed during servicing, these ground wires must be reconnected to ensure that the dryer is properly grounded.

W001

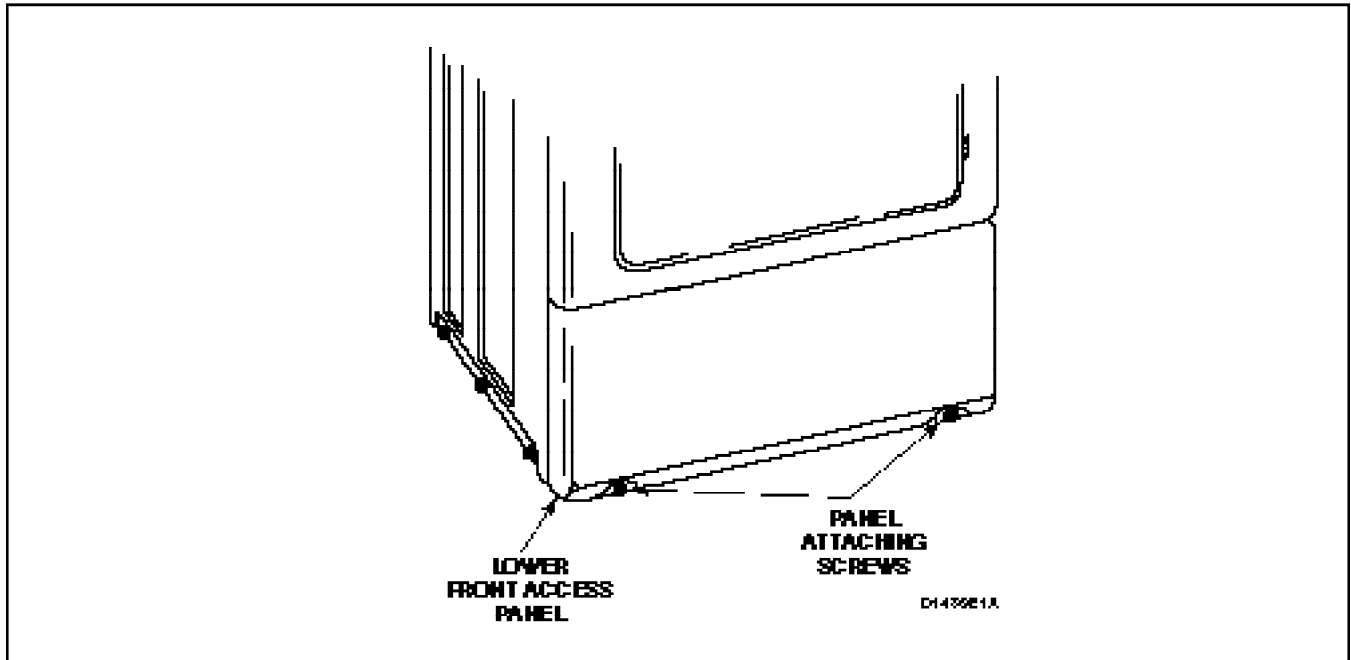

Figure 51

50. ELECTRICAL CIRCUIT TO IGNITION SYSTEM

- While supporting the lower access panel, remove two screws from bottom edge of lower access panel, *Figure 51*.
- Gently lower the access panel to disengage guide lugs from bottom edge of front panel.
- Close gas shut-off valve, *Figure 48*.
- Remove valve wire harness disconnect block from the holding and booster coil, *Figure 51*.
- Plug dryer power cord into wall receptacle, start the dryer in a heat setting (refer to the Operating Instructions supplied with dryer).
- Set test meter to read AC voltage and apply meter probes into terminals on the dryer harness that would correspond to terminals 1 and 2 on the coil, *Figure 45*. Meter should register line voltage in all Fabric settings, except FLUFF which should read "zero" VAC.
- If meter does not read line voltage in step "f", check motor switch, thermostats, fabric switch, or timer.

a WARNING

- To reduce the risk of electric shock, fire, explosion, serious injury or death:
- Disconnect electric power to the dryer before servicing.
 - Close gas shut-off valve to the dryer before servicing.
 - Never start the dryer with any guards/panels removed.
 - Whenever ground wires are removed during servicing, these ground wires must be reconnected to ensure that the dryer is properly grounded.

W001

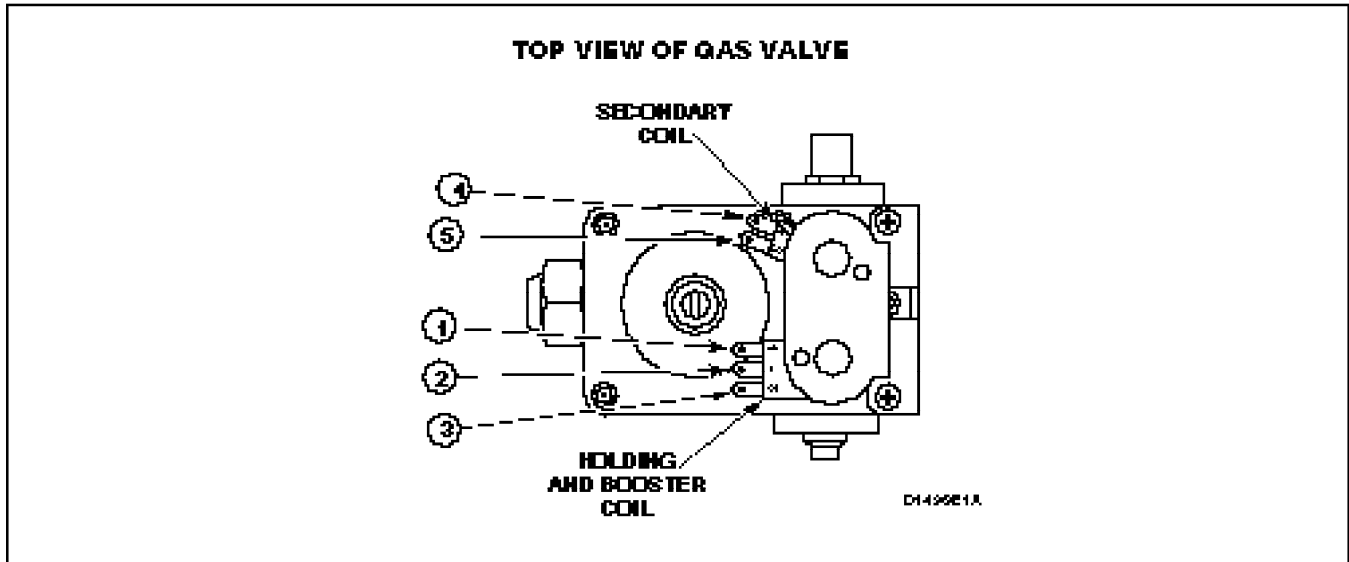

Figure 52

51. GAS VALVE COILS

a WARNING

To reduce the risk of fire, explosion and electric shock, close the valve in the gas supply line to the gas dryer and disconnect the electrical power unless gas or power supplies are required to perform test procedure.

- While supporting the lower access panel, remove two screws from bottom edge of lower access panel, *Figure 51*.
- Gently lower the access panel to disengage guide lugs from bottom edge of front panel.
- Close gas shut-off valve, *Figure 48*.
- Remove disconnect blocks from gas valve coils.

- Set test meter to read OHMS and put meter probes to terminals as in *Figure 52*, and the chart below.

COIL TOLERANCE READINGS

	60 Hertz
Holding Coil Terminals 1 & 2	1365 ± 25 Ohms
Booster Coil Terminals 1 & 3	560 ± 25 Ohms
Secondary Coil Terminals 4 & 5	1220 ± 50 Ohms

NOTE: If meter registers any other readings than those listed above, the respective coil(s) should be replaced.

a WARNING

- To reduce the risk of electric shock, fire, explosion, serious injury or death:
- Disconnect electric power to the dryer before servicing.
 - Close gas shut-off valve to the gas dryer before servicing.
 - Never start the dryer with any guards/panels removed.
 - Whenever ground wires are removed during servicing, these ground wires must be reconnected to ensure that the dryer is properly grounded.

W001

52. SENSOR

- While supporting the lower access panel, remove two screws from bottom edge of lower access panel, *Figure 51*.
- Gently lower the access panel to disengage guide lugs from bottom edge of front panel.
- Close gas shut-off valve, *Figure 48*.
- Remove wires from sensor terminals, *Figure 52*.
- Set test meter to read OHMS, put meter probes on sensor terminals. Meter should read "zero" Ohms. If meter registers an Ohm reading of any amount, replace sensor.

53. IGNITER

Gas dryers are manufactured with different igniters. These igniters are tested in the same way, but have different resistance readings.

- While supporting the lower access panel, remove two screws from bottom edge of lower access panel.
- Gently lower the access panel to disengage guide lugs from bottom edge of front panel.
- Disconnect igniter wires at disconnect block.
- Set test meter to read Ohms and put meter probes on terminals of igniter wires.
- Norton Igniter** — meter should read between 45-200 OHMS, *Figure 53*.
60868 Igniter — meter should read between 75-800 OHMS, *Figure 53*.

If meter does not read appropriate OHMS, then replace the igniter.

IMPORTANT: Always examine all wires, terminals and connectors to be sure wiring is proper before replacing any components.

NOTE: Test procedures of paragraph 51, 52 and 53 can be performed on workbench if gas valve, igniter, burner tube and burner housing have been removed from dryer.

54. TEMPERATURE SWITCH

- Remove three screws holding the control assembly to the control hood rear panel and cabinet top, *Figures 5 and 6*.
- Disconnect wires from temperature switch.
- Set the meter to read OHMS and apply the meter probes to the switch terminals.
 - Three Position Heat Switch** — Follow the appropriate wiring diagram for your model dryer. See SECTION VII of this manual.
 - Infinite Heat Switch** — Meter should read 10 Ohms (maximum) with the switch in the DELICATE setting. Turn switch full CLOCKWISE direction, meter should read 10,000 Ohms (minimum).

NOTE: Refer to proper wiring diagram when reconnecting wires.

	L1 - 1	L1 - 2	L1 - 3
Perm. Press and Regular	--	X	--
Delicate	X	X	--
Fluff	--	--	X

X indicates closed

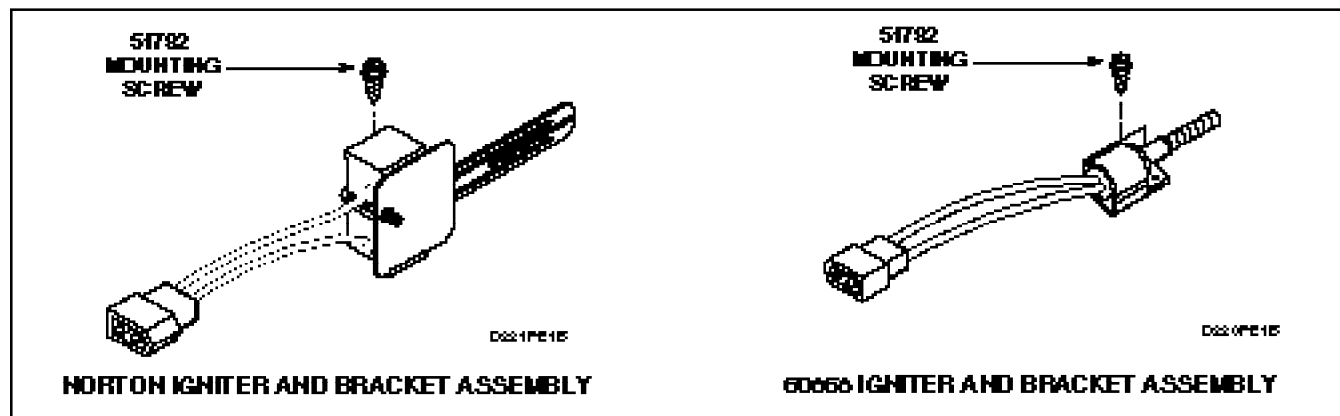

Figure 53

a WARNING

To reduce the risk of electric shock, fire, explosion, serious injury or death:

- Disconnect electric power to the dryer before servicing.
- Close gas shut-off valve to gas dryer before servicing.
- Never start the dryer with any guards/panels removed.
- Whenever ground wires are removed during servicing, these ground wires must be reconnected to ensure that the dryer is properly grounded.

W001

55. DOOR SWITCH

- a. While supporting the lower access panel, remove two screws from bottom edge of lower access panel, *Figure 22*.
- b. Gently lower the access panel to disengage guide lugs from bottom edge of front panel.
- c. Disconnect wires from door switch, *Figure 21*.

NOTE: Refer to appropriate wiring diagram when rewiring switch.

- d. Set meter to read Ohms and apply meter probes on switch terminals 1 and 3 with door closed. You should get "zero" reading.
- e. Apply probes to terminals 1 and 2 with door closed. The meter should read "no reading".
- f. Open door. Meter should read "zero".

56. SIGNAL CONTROL

- a. Remove the three screws holding the control assembly to the control hood rear panel, *Figures 5, 6 and 8*.
- b. Disconnect wires from signal control.
- c. Set meter to read Ohms and apply meter probes to terminals of signal control. Meter should read approximately 1,000 Ohms at all times.

57. TIMER ADVANCE and TIMER CONTACT POINTS (*Figure 54*)

This test will determine if the timer advances. If the timer advances then it does not need to be replaced.

Advance Test:

For models which produce an audible signal (a buzzing sound):

1. Select a cycle and activate dryer start switch.

2. Rotate timer knob to a position where the signal will activate, then release timer knob.
3. If timer is advancing, signal will end in less than 10 minutes.
4. If signal continues to sound for more than 10 minutes, replace timer.

For models which do not produce an audible signal:

1. Rotate timer knob to the 10 minute mark.
2. If timer is advancing, dryer will cycle into the cool down period and then to OFF position.

NOTE: If timer does not advance, see paragraph 9 for timer replacement.

To check timer contact points proceed as follows:

- a. Remove the three screws holding the control assembly to the control hood rear panel, *Figures 5, 6 and 8*.
- b. Disconnect wires from timer.

NOTE: Refer to appropriate wiring diagram when rewiring timer.

- c. Set test meter to read OHMS and apply meter probes to terminals, *Figure 54*.
- d. Starting with timer knob indicator in OFF position at top of timer, slowly turn timer knob clockwise until indicator is again pointing toward OFF position at top of timer. Meter should register "zero" reading when circuit being tested is completed by timer. Refer to *Figure 54* for Timer Cycle Chart showing when circuit is made.

Timer Motor Resistance Check

120V 60 Hz. motor resistance 2,460 - 3,100 Ohms.

a WARNING

To reduce the risk of electric shock, fire, explosion, serious injury or death:

- Disconnect electric power to the dryer before servicing.
- Close gas shut-off valve to gas dryer before servicing.
- Never start the dryer with any guards/panels removed.
- Whenever ground wires are removed during servicing, these ground wires must be reconnected to ensure that the dryer is properly grounded.

W001

CIRCUIT TO BE TESTED	TIMER No. 502963	TIMER No. 59420	TIMER No. 502967	TIMER No. 501881
Timer Motor	L2 and T	-	L2 and T	L2 and T
Signal Control	P/B - P/B	P and B	P/B - P/B	-
Motor	L 1 and M	L1 and M	L1 and M	L1 and M
Heat	L2 and H	L2 and H	L2 and H	L2 and H
Push-to-Start	M and S	M and S	M and S	M and S

Figure 54

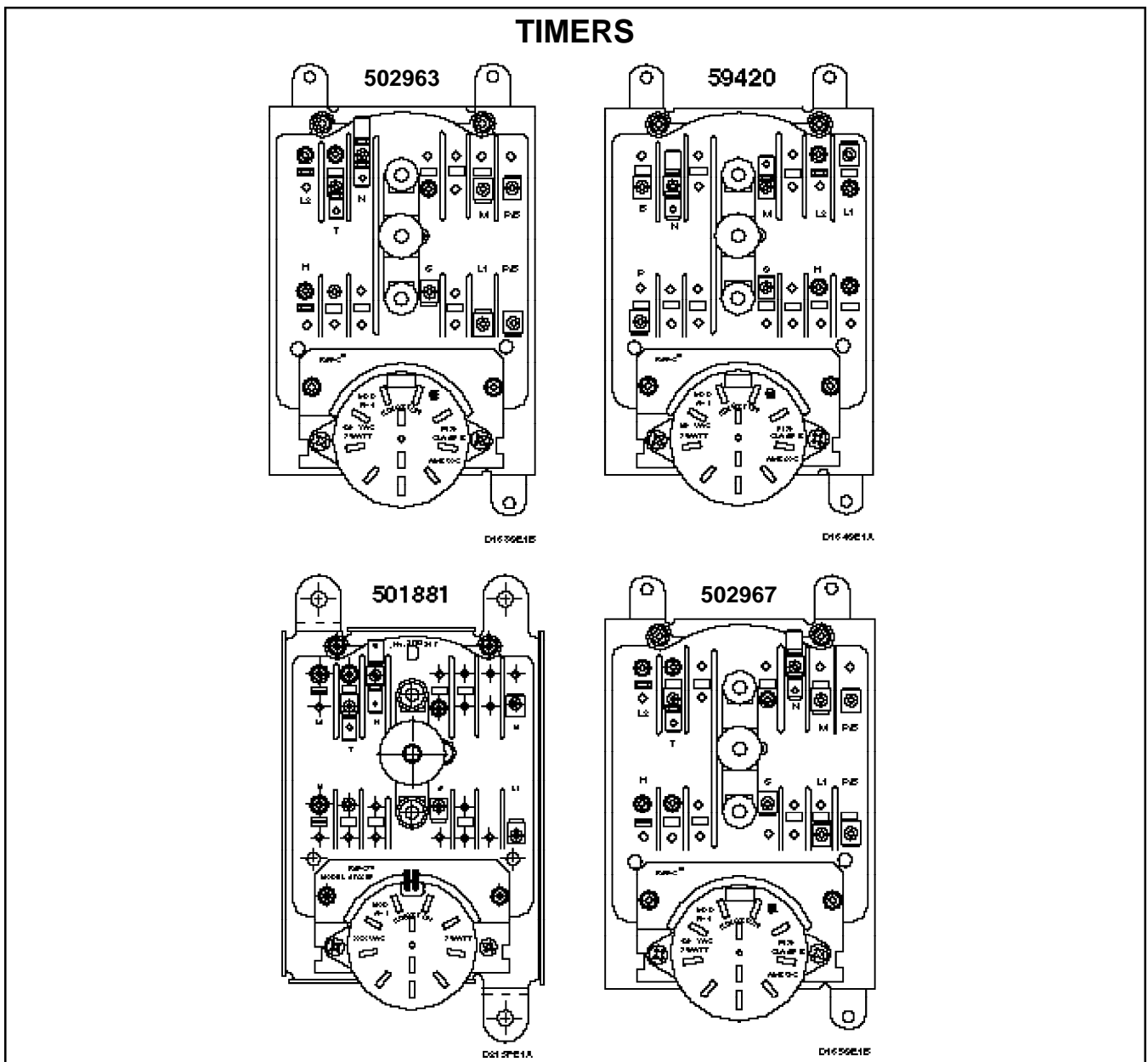

Figure 55

a WARNING

To reduce the risk of electric shock, fire, explosion, serious injury or death:

- Disconnect electric power to the dryer before servicing.
- Close gas shut-off valve to gas dryer before servicing.
- Never start the dryer with any guards/panels removed.
- Whenever ground wires are removed during servicing, these ground wires must be reconnected to ensure that the dryer is properly grounded.

W001

58. CYCLING OR LIMIT THERMOSTAT

- While supporting the lower access panel, remove two screws from bottom edge of lower access panel, *Figure 51*.
- Gently lower the access panel to disengage guide lugs from bottom edge of front panel.
- Disconnect wires from thermostat, *Figure 26* or *27*.

NOTE: Refer to appropriate wiring diagram when rewiring thermostat.

Cycling Thermostat (S.P.S.T.) or Limit Thermostat

- Set meter to read OHMS.
- Apply meter probes to the thermostat terminals.
- Meter should read "zero".

Cycling Thermostat (S.P.D.T.)

- Set meter to read OHMS.
- Apply meter probes to terminals 1 and 3. Meter should read "zero".
- Remove screws holding thermostat to exhaust fan cover.
- Heat thermostat with a small flame until a distinct "click" is heard, then immediately apply meter probes to terminals 1 and 2. Meter should read "zero".

59. THERMOSTAT HEATER

- While supporting the lower access panel, remove two screws from bottom edge of lower access panel, *Figure 51*.
- Gently lower the access panel to disengage guide lugs from bottom edge of front panel.
- Disconnect wires from thermostat/heater, *Figure 27*.

NOTE: Refer to appropriate wiring diagram when rewiring thermostat heater.

- Set meter to read OHMS. Apply meter probes to the thermostat heater terminals. Meter should read as follows: (Cold Ohms)

120 Volt 60 Hz. 2400 ± 240 Ohms.

a WARNING

To reduce the risk of electric shock, fire, explosion, serious injury or death:

- Disconnect electric power to the dryer before servicing.
- Close gas shut-off valve to gas dryer before servicing.
- Never start the dryer with any guards/panels removed.
- Whenever ground wires are removed during servicing, these ground wires must be reconnected to ensure that the dryer is properly grounded.

W001

60. THERMAL FUSE (Electric Models)

- While supporting the lower access panel, remove two screws from bottom edge of lower access panel, *Figure 51*.
- Gently lower the access panel to disengage guide lugs from bottom edge of front panel.
- Disconnect wires from thermal fuse, *Figure 26*.

NOTE: Refer to appropriate wiring diagram when rewiring thermal fuse.

- Set multimeter to read OHMS on the X1 scale. Apply meter probes to the thermal fuse terminals. Multimeter should read 0 OHMS. If the meter does not show any reading (infinite OHMS), then the fuse is open. If the fuse is open, then replace BOTH the thermal fuse and the limit thermostat.

61. HEATER ASSEMBLY (Electric Models)

- While supporting the lower access panel, remove two screws from bottom edge of lower access panel, *Figure 51*.

- Gently lower the access panel to disengage guide lugs from bottom edge of front panel.
- Disconnect wire from heater assembly, *Figure 26*.

NOTE: Refer to appropriate wiring diagram when rewiring heater assembly.

- Set meter to read OHMS. Apply meter probes to the heater assembly terminals. Meter should read as follows: (Cold Ohms)

Color	Voltage/Hz.	Resistance Reading
Red	240 V 60 Hz.	10.39 ± .31 Ohms cold
White	208 V 60 Hz.	8. 2 ± .5 Ohms Cold

SECTION V

Service Helps

a WARNING

- To reduce the risk of electric shock, fire, explosion, serious injury or death:
- Disconnect electric power to the dryer before servicing.
 - Close gas shut-off valve to gas dryer before servicing.
 - Never start the dryer with any guards/panels removed.
 - Whenever ground wires are removed during servicing, these ground wires must be reconnected to ensure that the dryer is properly grounded.

W001

IMPORTANT: Refer to appropriate Wiring Diagram for aid in testing dryer components.

62. MOTOR DOES NOT RUN

POSSIBLE CAUSE	TO CORRECT
Electrical power off, fuse blown, or power cord not plugged in.	Has the laundry room fuse(s) blown or become loosened, or are circuit breakers open? The dryer itself does not have an electrical fuse. Be sure to check both fuses on Electric models.
Loading door not closed or inoperative door switch.	Close door or test switch and replace if inoperative.
Timer improperly set.	Reset timer, or try another cycle.
Inoperative timer.	Test timer and replace if inoperative.
Motor starting functions inoperative. No Start; or Motor hums only.	Refer to MOTOR TEST SECTION to check start switch and start windings.
Motor is dead, won't run.	Refer to MOTOR TEST SECTION to check start switch and start windings.
Motor overload protector has cycled.	Wait two or three minutes for overload protector to reset. If protector cycles repeatedly, refer to <i>paragraph 63</i> .
Motor centrifugal switch sticky or plugged with lint.	Remove dust or lint and spray with "SLYDE", No. 131P4, to clean and lubricate.
Bind in motor bearing.	Remove belts and determine if motor shaft will spin. Replace motor if shaft is locked up.
Loose motor wire harness connection block.	Firmly press connection block onto motor switch.
Broken, loose, or incorrect wiring.	Refer to appropriate wiring diagram.
Power cord is miswired.	Refer to appropriate wiring diagram for the correct wiring.
Inoperative electronic control.	Refer to SECTION VII to check out the electronic control operation.

*Mechanical Timer Models only
 =Electronic Control Models only

a WARNING

- To reduce the risk of electric shock, fire, explosion, serious injury or death:
- Disconnect electric power to the dryer before servicing.
 - Close gas shut-off valve to the dryer before servicing.
 - Never start the dryer with any guards/panels removed.
 - Whenever ground wires are removed during servicing, these ground wires must be reconnected to ensure that the dryer is properly grounded.

W001

63. UNIT STOPS IN CYCLE; QUILTS AFTER A COUPLE LOADS; HAS A BURNING SMELL; CYCLES ON MOTOR THERMAL PROTECTOR.

POSSIBLE CAUSE	TO CORRECT
Incorrect Voltage.	See nameplate in door well for correct voltage. Refer to INSTALLATION INSTRUCTIONS (supplied with dryer) for electrical requirements.
Clothes load too large.	Remove part of load. A normal washer load is a normal dryer load. Maximum load: Dryer cylinder one half full of wet clothes.
Clothes cylinder is binding.	Check cylinder for binding and “out of round” condition. Also check front and rear bulkheads for warping. Check support rollers for binding. Check cylinder seals and glides for wear or damage. Check for clothes lodged between cylinder baffle and bulkhead.
Broken, loose or incorrect wiring.	Refer to appropriate wiring diagram.
Motor switch functions inoperative. Short in motor winding.	Refer to MOTOR TEST SECTION to check switch and windings.

64. MOTOR RUNS BUT CYLINDER DOES NOT TURN

POSSIBLE CAUSE	TO CORRECT
Motor drive pulley loose.	Tighten pulley.
Belt not installed on pulley.	Install belt, refer to Motor and Exhaust Assembly section.
Broken cylinder belt.	Replace belt.
Clothes cylinder is binding.	<ul style="list-style-type: none"> · Check cylinder for binding and “out of round” condition. · Check front and rear bulkheads for warping. · Check cylinder rollers for binding. · Check cylinder seals and glides for wear or damage.
Broken, weak or disconnected idler lever spring.	Replace or reconnect spring, refer to Motor and Exhaust Assembly section.
Belt routed on wrong side of idler lever.	Reroute belt , refer to Motor and Exhaust Assembly section.
Oil on cylinder.	Wipe oil from cylinder.
Belt is “inside out”.	Reinstall belt with ribbed surface against cylinder.
Idler arm is binding.	<ul style="list-style-type: none"> · Add grease between idler arm and motor mount. · Replace idler arm and bolt if needed.
Dryer is overloaded.	Load dryer half full of laundry.
Wrong motor.	Refer to Parts manual for proper motor part number.
Wrong belt used on dryer.	<ul style="list-style-type: none"> · Check belt part number against correct part number in the Parts manual. · Replace belt if needed.
Bent idler arm.	Replace idler arm.

*Mechanical Timer Models only
 =Electronic Control Models only

a WARNING

- To reduce the risk of electric shock, fire, explosion, serious injury or death:
- Disconnect electric power to the dryer before servicing.
 - Close gas shut-off valve to gas dryer before servicing.
 - Never start the dryer with any guards/panels removed.
 - Whenever ground wires are removed during servicing, these ground wires must be reconnected to ensure that the dryer is properly grounded.

W001

65. MOTOR DOES NOT STOP

POSSIBLE CAUSE	TO CORRECT
Incorrect wiring to motor switch.	Refer to appropriate wiring diagram.
Motor centrifugal switch sticky or plugged with lint.	Remove dust or lint and spray with "SLYDE", No. 131P4, to clean and lubricate.
Inoperative door switch.	Test switch and replace if inoperative.
*Inoperative timer — nonmetered models.	Test timer and replace if inoperative.
=Inoperative electronic control.	Refer to SECTION VII to check out the electronic control operation.
Inoperative moisture sensing control.	Refer to SECTION VIII to check out the moisture sensing control operation.

66. HEATING ASSEMBLY DOES NOT HEAT OR BURNER DOES NOT IGNITE.

POSSIBLE CAUSE	TO CORRECT
Improper or inadequate exhaust system.	See INSTALLATION INSTRUCTIONS (supplied with dryer) for exhaust requirements.
Use of plastic or thin foil exhaust duct.	Replace with solid or rigid flexible metal exhaust duct.
Blown house fuse or tripped circuit breaker.	Check fuses or circuit breakers. A 240 Volt dryer has two fuses — Make sure both fuses are good.
*Temperature selector switch set at FLUFF, or inoperative.	Reset switch, or test switch and replace if inoperative.
*Timer improperly set (Set in a cool-down period, or a no heat cycle).	Reset timer. Try another cycle.
Inoperative limit thermostat.	Test thermostat and replace if inoperative.
Electric Models: Inoperative heater assembly.	Test heater assembly. Replace heater assembly if cold Ohms do not read between 8 and 10.5 Ohms.
Gas Models: Insufficient gas supply.	Check gas shut-off valve in dryer and main gas line valve. Open partially closed gas shut-off valve, or correct low gas pressure.
Inoperative drive motor switch.	Test switch and replace if inoperative.
Gas Models: Inoperative gas valve coils.	Test coils and replace if inoperative, refer to <i>paragraph 51</i> .
Gas Models: Inoperative flame sensor.	Test flame sensor and replace if inoperative. Refer to <i>paragraph 52</i> .
Gas Models: Inoperative igniter.	Test igniter and replace if inoperative. Refer to <i>paragraph 53</i> .
Gas Models: Harness not properly connected to gas controls.	Check harness connections to gas valve coils, sensor and main harness. Reconnect as required.
Gas Models: Restricted gas flow in gas orifice.	Clean out gas orifice.
Electric Models: Inoperative thermal fuse.	Test thermal fuse and replace if inoperative.
*Inoperative cycling thermostat.	Test thermostat and replace if inoperative.
*Inoperative timer.	Test timer and replace if inoperative.
=Inoperative electronic control.	Refer to SECTION VII to check out the electronic control operation.

*Mechanical Timer Models only
 =Electronic Control Models only
 RS3200001 (502992R3)
 Rev. 3

(continued)

a WARNING

- To reduce the risk of electric shock, fire, explosion, serious injury or death:
- Disconnect electric power to the dryer before servicing.
 - Close gas shut-off valve to gas dryer before servicing.
 - Never start the dryer with any guards/panels removed.
 - Whenever ground wires are removed during servicing, these ground wires must be reconnected to ensure that the dryer is properly grounded.

W001

66. HEATING ASSEMBLY DOES NOT HEAT OR BURNER DOES NOT IGNITE. (cont.)

POSSIBLE CAUSE	TO CORRECT
=Read-out on electronic control indicates "SH".	Thermistor is shorted, replace thermistor.
=Read-out on electronic control indicates "OP".	Thermistor is open, replace thermistor.
Broken, loose, or incorrect wiring.	Refer to appropriate wiring diagram.
Inoperative moisture sensing control.	Refer to SECTION VIII to check out the moisture sensing control.

67. IGNITER DOES NOT GLOW (gas supply sufficient) — GAS MODELS

POSSIBLE CAUSE	TO CORRECT
*No power to power leads on valve.	Check timer, selector switch, thermostats, motor switch, and wiring.
Flame sensor failed with contacts open.	Replace flame sensor.
Igniter broken or open.	Replace igniter.
=Inoperative electronic control.	Refer to SECTION VII to check out the electronic control operation.
Inoperative moisture sensing control.	Refer to SECTION VIII to check out the moisture sensing control.

68. BURNER IGNITES AND GOES OUT REPEATEDLY — GAS MODELS

POSSIBLE CAUSE	TO CORRECT
Improper or inadequate exhaust system. Weather hood flapper restricted.	See INSTALLATION INSTRUCTIONS (supplied with dryer) for exhaust requirements.
Burner heat not holding flame sensor contacts open.	Replace flame sensor, or correct gas supply problem.
Insufficient gas supply.	Check gas supply and pressure. Is gas shut-off valve turned on?
Cracked igniter.	Replace igniter and bracket.
Inoperative or intermittent gas valve coils.	Check and replace appropriate coil. Refer to <i>paragraph 51</i> .

69. IGNITER GLOWS BUT BURNER DOES NOT IGNITE — GAS MODELS

POSSIBLE CAUSE	TO CORRECT
Flame sensor failed in closed position.	Replace flame sensor.
Open secondary coil or holding coil.	Replace gas valve (in-warranty), or replace coils (out-of-warranty). Refer to <i>paragraph 51</i> .
Insufficient gas supply.	Check gas supply and pressure. Is gas shut-off valve turned on?
Igniter and bracket installed improperly on burner tube assembly.	Loosen screw and properly position igniter and bracket on burner tube assembly.
Flame sensor installed improperly on burner housing.	Loosen screw and properly position the flame sensor on the burner housing.

*Mechanical Timer Models only
 =Electronic Control Models only

a WARNING

- To reduce the risk of electric shock, fire, explosion, serious injury or death:
- Disconnect electric power to the dryer before servicing.
 - Close gas shut-off valve to gas dryer before servicing.
 - Never start the dryer with any guards/panels removed.
 - Whenever ground wires are removed during servicing, these ground wires must be reconnected to ensure that the dryer is properly grounded.

W001

70. HEATER ASSEMBLY OR BURNER SHUTS OFF PREMATURELY

POSSIBLE CAUSE	TO CORRECT
Improper or inadequate exhaust system. Weather hood flapper restricted.	See INSTALLATION INSTRUCTIONS (supplied with dryer) for exhaust requirements.
Gas Models: Insufficient gas supply.	Check gas shut-off valve in dryer and main gas line valve. Open partially closed gas shut-off valve, or correct low pressure.
Gas Models: Dryer not properly equipped for type of gas used.	Refer to "Gas Burner Conversion Procedures" supplied in gas burner conversion kit.
Gas Models: Improperly adjusted burner flame.	Adjust flame, <i>paragraph 47</i> .
Cycling off on limit thermostat.	Momentarily connect a jumper wire across thermostat terminals. If heater element heats or burner ignites when jumper wire is connected, refer to <i>paragraph 69</i> .
Gas models: Flame sensor contact closing	Replace flame sensor or adjust burner flame, prematurely. Burner flame improperly adjusted <i>paragraph 47</i> .
*Inoperative cycling thermostat.	Test thermostat and replace if inoperative.
*Inoperative timer.	Test timer and replace if inoperative.
Broken, loose, or incorrect wiring.	Refer to appropriate wiring diagram.
=Inoperative electronic control.	Refer to SECTION VII to check out the electronic control operation.
Inoperative moisture sensing control.	Refer to SECTION VIII to check out the moisture sensing control.

71. HEATER ASSEMBLY OR BURNER REPEATEDLY CYCLES OFF ON LIMIT THERMOSTAT

POSSIBLE CAUSE	TO CORRECT
External exhaust system longer or providing greater restriction than recommended.	Refer to INSTALLATION INSTRUCTIONS (supplied with dryer) for exhaust system requirements.
Use of plastic or thin foil exhaust duct.	Replace with solid or rigid flexible metal exhaust duct.
Clogged lint filter.	Clean lint filter.
Lint in internal dryer ductwork.	Disassemble dryer ductwork and clean.
Lint or other obstruction in external exhaust system.	Disassemble and clean exhaust system.
Hinged damper on exhaust system weather hood not free to open.	Free hinged damper or replace weather hood.
*Limit thermostat cycling at too low a temperature.	Replace thermostat, <i>paragraph 26</i> .
Air leak around loading door. (Door not sealing due to damaged seal or inoperative door catch.)	Replace seal or catch.
=Inoperative thermistor.	Test thermistor and replace if inoperative.
Air leak at blower seal.	Check and replace seal if necessary.
Air leak at cylinder seal(s).	Check and replace seal(s) if necessary.

*Mechanical Timer Models only

=Electronic Control Models only

a WARNING

- To reduce the risk of electric shock, fire, explosion, serious injury or death:
- Disconnect electric power to the dryer before servicing.
 - Close gas shut-off valve to gas dryer before servicing.
 - Never start the dryer with any guards/panels removed.
 - Whenever ground wires are removed during servicing, these ground wires must be reconnected to ensure that the dryer is properly grounded.

W001

72. HEATER ASSEMBLY OR BURNER DOES NOT SHUT OFF

POSSIBLE CAUSE	TO CORRECT
Improper motor switch. (Timer must be in a heat setting.)	Test switch and replace if inoperative.
Motor does not stop.	Refer to <i>paragraph 65</i> .
Incorrect wiring.	Refer to appropriate wiring diagram.
Heater assembly shorted.	Remove heater assembly and check for short.

73. CLOTHES DO NOT DRY

POSSIBLE CAUSE	TO CORRECT
Heater assembly does not heat or burner does not ignite.	Refer to <i>paragraph 66</i> .
Too much water in articles being dried.	Remove excess water.
Clothes load too large.	Remove part of load. A normal washer load is normal dryer load. Maximum load: Dryer cylinder one half full of wet clothes.
Excessive lint on lint filter.	Clean lint filter.
Load too small.	Add one or two bath towels to load.
Automatic cycle.	Adjust to more dry setting.
Three position heat selector switch on timer set on FLUFF or inoperative.	Reset switch or timer, or test and replace the switch or timer if inoperative.
Improper or inadequate exhaust system.	See INSTALLATION INSTRUCTIONS (supplied with dryer) for exhaust requirements.
Heater assembly or burner shuts off prematurely.	Refer to <i>paragraph 70</i> .
Gas Models: Gas line pressure too high or too low.	If Natural Gas line pressure to dryer exceeds 8 inch water column pressure, or is lower than 4 inch water column, ask Gas Company to correct.
Inoperative moisture sensing control.	Refer to SECTION VIII to check out the moisture sensing control.
Improper belt installation (Low RPM) if belt connected on motor shaft.	Check for proper installation, <i>Figure 30</i> .

*Mechanical Timer Models only
 =Electronic Control Models only

a WARNING

- To reduce the risk of electric shock, fire, explosion, serious injury or death:
- Disconnect electric power to the dryer before servicing.
 - Close gas shut-off valve to gas dryer before servicing.
 - Never start the dryer with any guards/panels removed.
 - Whenever ground wires are removed during servicing, these ground wires must be reconnected to ensure that the dryer is properly grounded.

W001

74. TIMER DOES NOT ADVANCE IN AUTOMATIC CYCLE (Mechanical Timer Models Only)

POSSIBLE CAUSE	TO CORRECT
Inoperative high or low thermostat	Test thermostat and replace if inoperative.
Heater assembly does not heat or burner does not ignite.	Refer to <i>paragraph 66</i> .
Heater assembly or burner cycles off prematurely.	Refer to <i>paragraph 70</i> .
Improper or inadequate exhaust system.	Refer to INSTALLATION INSTRUCTIONS (supplied with dryer) for exhaust requirements.
*Drying large load.	Timer will not advance until the load is almost dry.
Broken, loose or incorrect wiring.	Refer to appropriate wiring diagram.
Timer motor is inoperative.	Select a drying cycle and activate start switch. Rotate timer knob until signal sounds. Release timer knob, signal should stop within ten minutes. If not, replace timer. Refer to <i>paragraph 57</i> .
Inoperative seals (air leaks).	Check and replace any inoperative seals in the following areas: <ol style="list-style-type: none"> 1. Seal between loading door and front panel. 2. Seal between front panel and front bulkhead. 3. Seal between blower cover and air duct. 4. Seal between cylinder and rear bulkhead.

75. CLOTHES ARE TOO HOT WHEN REMOVED FROM DRYER

POSSIBLE CAUSE	TO CORRECT
Improper or inadequate exhaust system.	Refer to INSTALLATION INSTRUCTIONS (supplied with dryer) for exhaust requirements.
Clothes are removed from dryer before cycle has completed.	Allow the dryer to complete the cycle through the cool-down to the OFF position.
Inoperative cycling thermostat. Inoperative thermostat heater on the DELICATE setting.	Test cycling thermostat or thermostat heater and replace if inoperative.
Inoperative timer (not allowing cool-down).	Test timer and replace if inoperative.
Inoperative moisture sensing control.	Refer to SECTION VIII to check out the moisture sensing control.
Inoperative seals (air leaks).	Check and replace any inoperative seals in the following areas: <ol style="list-style-type: none"> 1. Seal between loading door and front panel. 2. Seal between front panel and front bulkhead. 3. Seal between blower cover and air duct. 4. Seal between cylinder and rear bulkhead.

SECTION VI

Internal Wiring of Dryer Motor Switch

WARNING

- To reduce the risk of electric shock, fire, explosion, serious injury or death:
- Disconnect electric power to the dryer before servicing.
 - Close gas shut-off valve to gas dryer before servicing.
 - Never start the dryer with any guards/panels removed.
 - Whenever ground wires are removed during servicing, these ground wires must be reconnected to ensure that the dryer is properly grounded.

W001

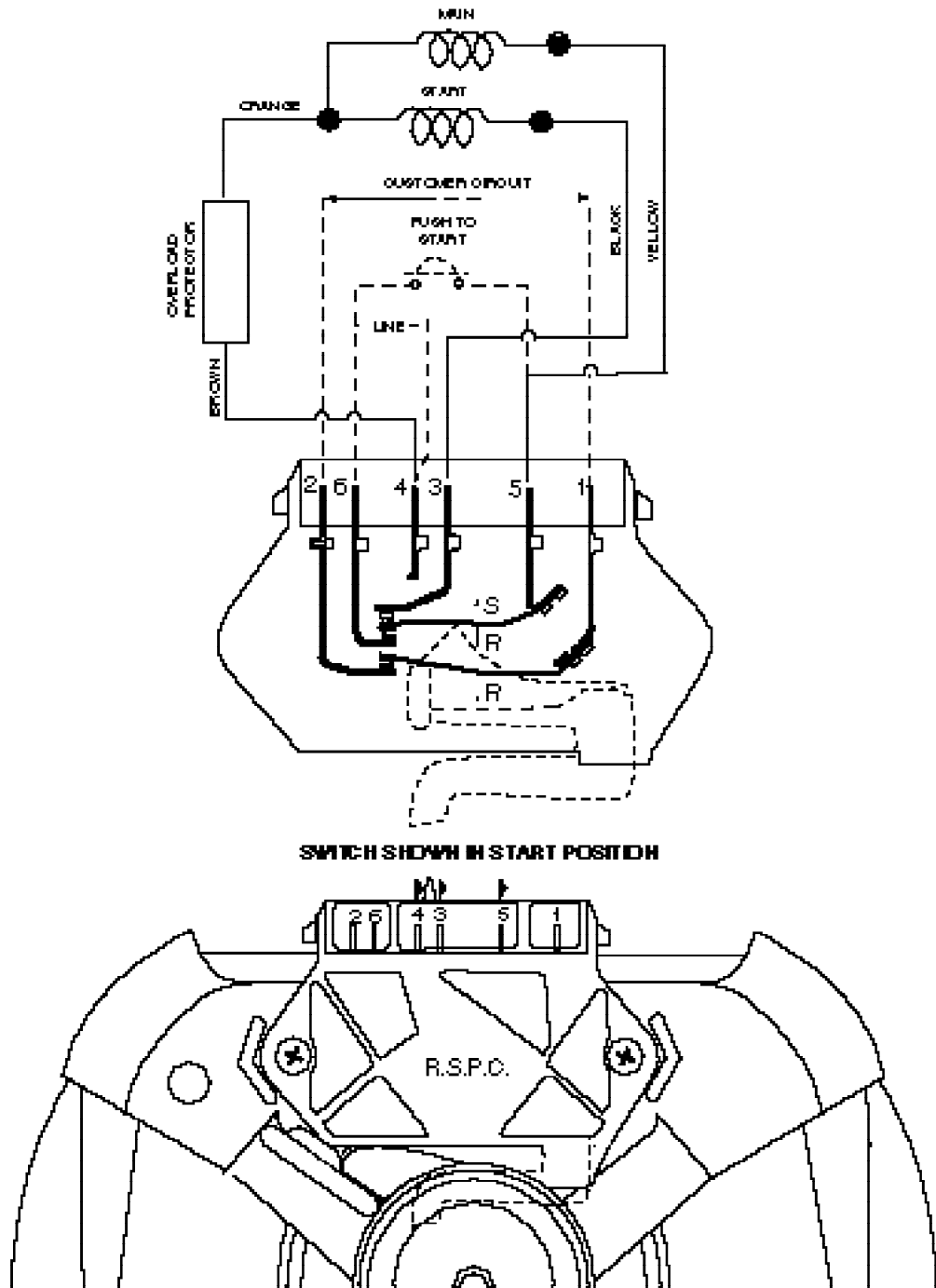

D166SE3A

SECTION VII

Service Procedures Unique to the Electronic Control Model Dryers

a WARNING

To reduce the risk of electric shock, fire, explosion, serious injury or death:

- Disconnect electric power to the dryer before servicing.
- Close gas shut-off valve to gas dryer before servicing.
- Never start the dryer with any guards/panels removed.
- Whenever ground wires are removed during servicing, these ground wires must be reconnected to ensure that the dryer is properly grounded.

W001

MODEL	Electronic Control Assembly PART NO.
LE9107, LE9207, LG9109, LG9209, CE9107, CE9207	500540
LE4807, LE4907, LG4809, LG4909	501273

Grounding and Wiring Instructions

- The dryer must be connected to a grounded metal, permanent wiring system; or an equipment-grounding conductor must be run with the circuit conductors and connected to the equipment-grounding terminal or lead on the dryer.
- The dryer has its own terminal block that must be connected to a separate branch, 60 Hertz single phase, AC (alternating current) circuit, fused at 30 Amperes (the circuit must be fused on both sides of the line). ELECTRICAL SERVICE FOR DRYER SHOULD BE OF MAXIMUM RATED VOLTAGE LISTED ON THE NAMEPLATE. DO NOT CONNECT DRYER TO 110, 115, OR 120 VOLT CIRCUIT. Heating elements are available for field installation in dryers which are to be connected to electrical service of different voltage than that listed on nameplate, such as 208.
- If branch circuit to dryer is 15 feet (4.50 m) or less in length, use U.L. (Underwriters Laboratories) listed No. 10 A.W.G. wire (copper wire only), or as required by local codes. If over 15 feet (4.50 m), use U.L. (Underwriters Laboratories) listed No. 8 A.W.G. wire (copper wire only), or as required by local codes. Allow sufficient slack in wiring so dryer can be moved from its normal location when necessary.
- The power cord (pigtail) connection between wall receptacle and dryer terminal block is NOT supplied with dryer. Type of pigtail and gauge of wire must conform to local codes and with instructions mentioned in previous paragraph.
- The method of wiring the dryer is optional and subject to local code requirements, *Figures 56 & 58*.

76. ELECTRICAL SERVICE

(Electric Dryer)
(120/240 Volt, 60 Hertz, 3-Wire Installation)
(120/208 Volt, 60 Hertz, 3-Wire Installation)

NOTE: The wiring diagram is located inside the control hood.

a WARNING

To reduce the risk of fire, electric shock or personal injury, all wiring and grounding MUST conform with the latest edition of the National Electrical Code, ANSI/NFPA No. 70, and such local regulations as might apply. IT IS THE CUSTOMER'S RESPONSIBILITY TO HAVE THE WIRING AND FUSES CHECKED BY A QUALIFIED ELECTRICIAN TO MAKE SURE YOUR HOME HAS ADEQUATE ELECTRICAL POWER TO OPERATE THE DRYER.

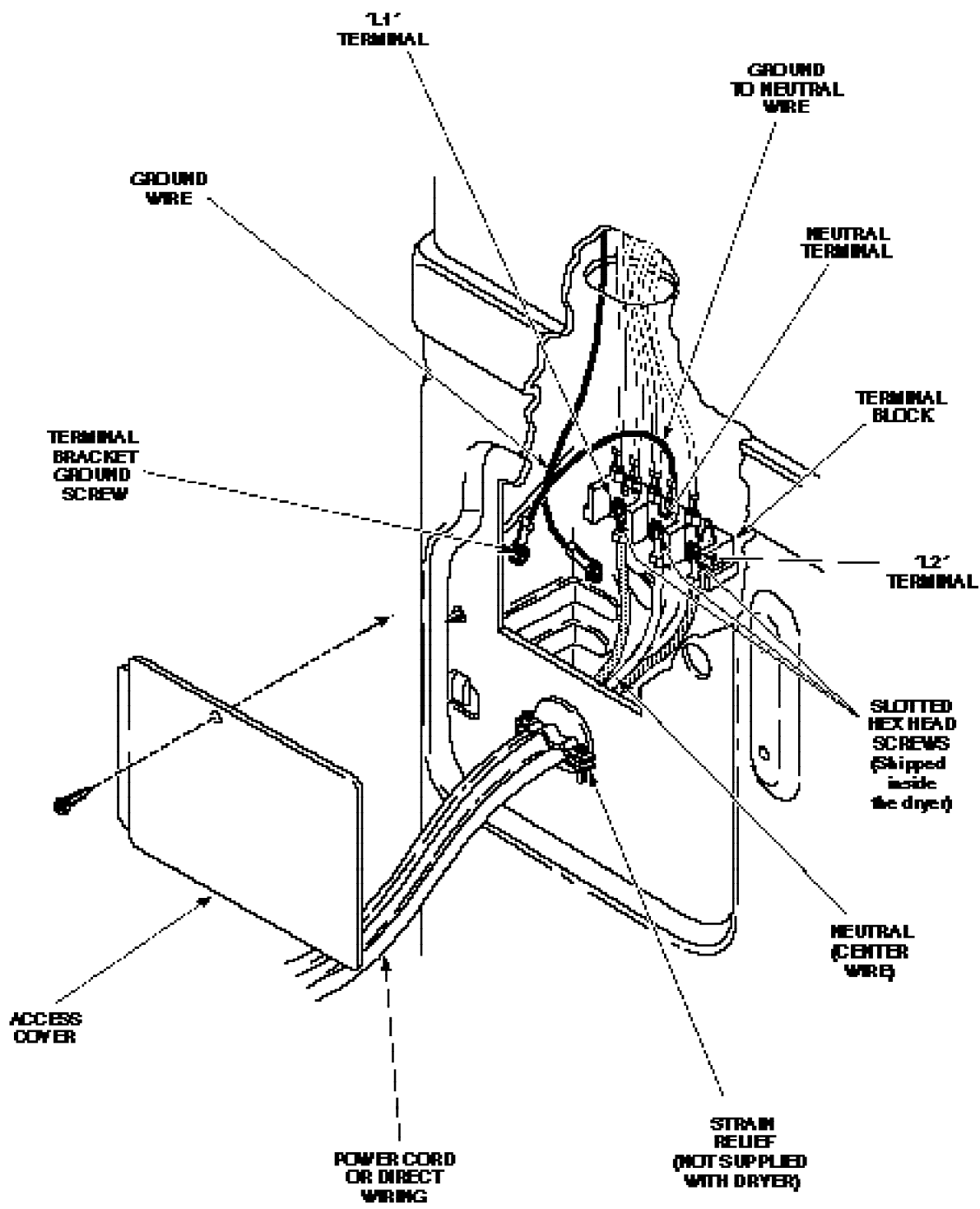

D15-4E3A

Three Wire Connection

Figure 56

a **WARNING**

To reduce the risk of electric shock, fire, explosion, serious injury or death:

- Disconnect electric power to the dryer before servicing.
- Close gas shut-off valve to gas dryer before servicing.
- Never start the dryer with any guards/panels removed.
- Whenever ground wires are removed during servicing, these ground wires must be reconnected to ensure that the dryer is properly grounded.

W001

Electrical Connection (Three-Wire)

IMPORTANT; This dryer is grounded to neutral conductor at the terminal block. If the dryer is installed in a mobile home, or if local codes do not permit grounding through the neutral, proceed as shown in *paragraph 77*.

- Remove screw and terminal block access cover from rear of dryer cabinet.
- Insert ends of wires through strain relief in rear of dryer cabinet. Connect the power cord, or direct wiring, to the appropriate terminal block terminals using the three-wire binding (10-32 x 3/8") screws from the accessories pack in the envelope shipped inside the dryer cylinder.

If the dryer had previously been connected with a four-wire power cord, remove the four-wire cord by reversing procedures under four-wire power cord.

IMPORTANT: Use only a U.L. listed No. 10 (copper wire only) three conductor power supply cord kit rated 240 Volts (minimum) 30 Amperes and labeled as suitable for use in a clothes dryer.

- Tighten these wire-binding screws firmly.

IMPORTANT: Failure to tighten these screws firmly may result in wire failure at the terminal block.

- Secure the strain relief to the power cord, or wires, where they enter the dryer cabinet.
- Reinstall access cover and screw.

Three Wire Plus Ground Wire Power Cord

IMPORTANT: Use only a U.L. listed No. 10 A.W.G. (copper wire only) four conductor power supply cord kit rated 240 Volts (minimum) 30 Amperes and labeled as suitable for use in a clothes dryer.

NOTE: The power cord is not supplied with the dryer when the dryer is shipped from the factory, therefore, disregard Steps 2 and 3 below when connecting a four-wire power cord to a NEW dryer.

If the dryer has a three-wire cord attached, then complete Steps a through k.

- Remove the screw holding the access plate to the rear of dryer cabinet.
- Remove three screws holding the three wires to terminal block terminals. Save these screws.
- Loosen the strain relief screw and pull the cord or wires out through the rear of the dryer.
- Remove the terminal bracket ground screw holding the ground wire to the terminal block mounting bracket. Save the screw.

NOTE: ON NEW DRYERS - This is the ground wire that goes from the neutral (center) terminal on the terminal block to the mounting bracket.

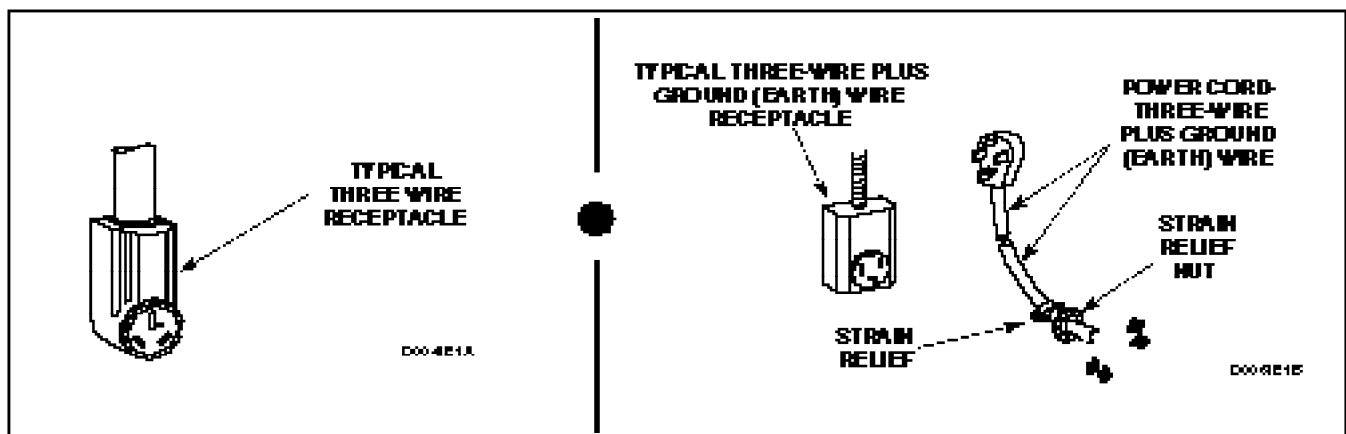

Figure 57

a WARNING

To reduce the risk of electric shock, fire, explosion, serious injury or death:

- Disconnect electric power to the dryer before servicing.
- Close gas shut-off valve to gas dryer before servicing.
- Never start the dryer with any guards/panels removed.
- Whenever ground wires are removed during servicing, these ground wires must be reconnected to ensure that the dryer is properly grounded.

W001

Install Three Wire Plus Ground Power Cord

- e. Route the end of the three wire plus ground (earth) power cord through the strain relief. DO NOT tighten the strain relief screws at this time.
- f. Insert the end of the power cord and strain relief through the hole in the rear of dryer cabinet, *Figure 58*. Install the strain relief nut from the inside of the cabinet and tighten firmly.
- g. Attach the ground wire (from the three wire plus ground [earth] power cord) to the terminal block mounting bracket using the hex head screw removed in Step d. Tighten the screw firmly.
- h. Using the three wire-binding (10-32x3/8") screws from the accessories envelope (located inside the cylinder, unless the screws were previously removed in Step b), attach the power cord wires to the terminal block terminals as follows:
 - (1) Red to Red
 - (2) Black to Black
 - (3) White to White (see NOTE below)

NOTE: When installing the white to white wire, loop the free eyelet end of the ground wire (from Step d) and place it together with the white wire. Attach both wires to the neutral (center) terminal on the terminal block, *Figure 58*.

IMPORTANT: Failure to tighten the screws firmly on the terminal block may result in terminal block failure.

- i. Tighten the two strain relief screws to secure the power cord.
- j. Recheck all screws to be sure they are tight.
- k. Reinstall the access plate and screw to the rear of the dryer cabinet.

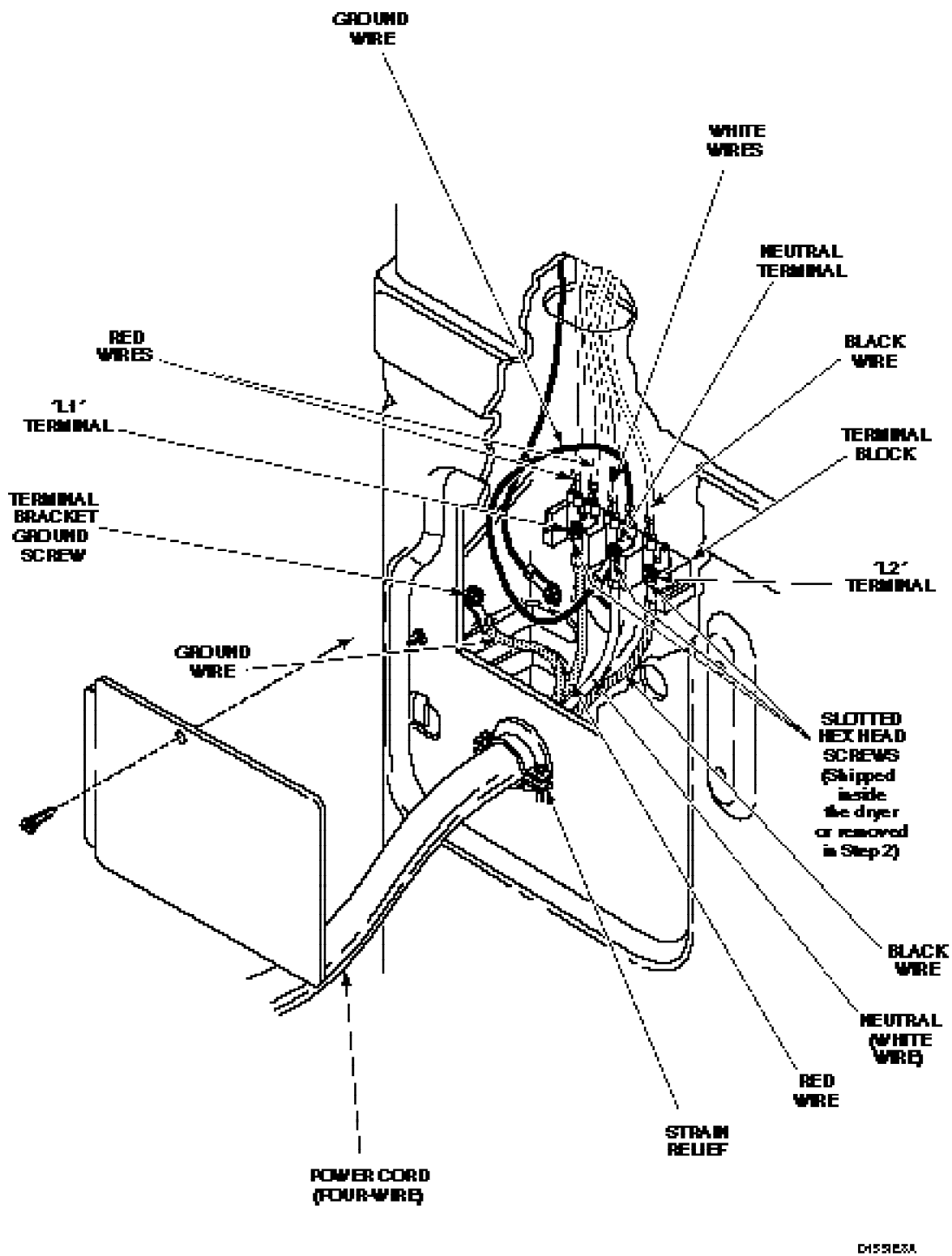

Four Wire Connection

Figure 58

a WARNING

To reduce the risk of electric shock, fire, explosion, serious injury or death:

- Disconnect electric power to the dryer before servicing.
- Close gas shut-off valve to gas dryer before servicing.
- Never start the dryer with any guards/panels removed.
- Whenever ground wires are removed during servicing, these ground wires must be reconnected to ensure that the dryer is properly grounded.

W001

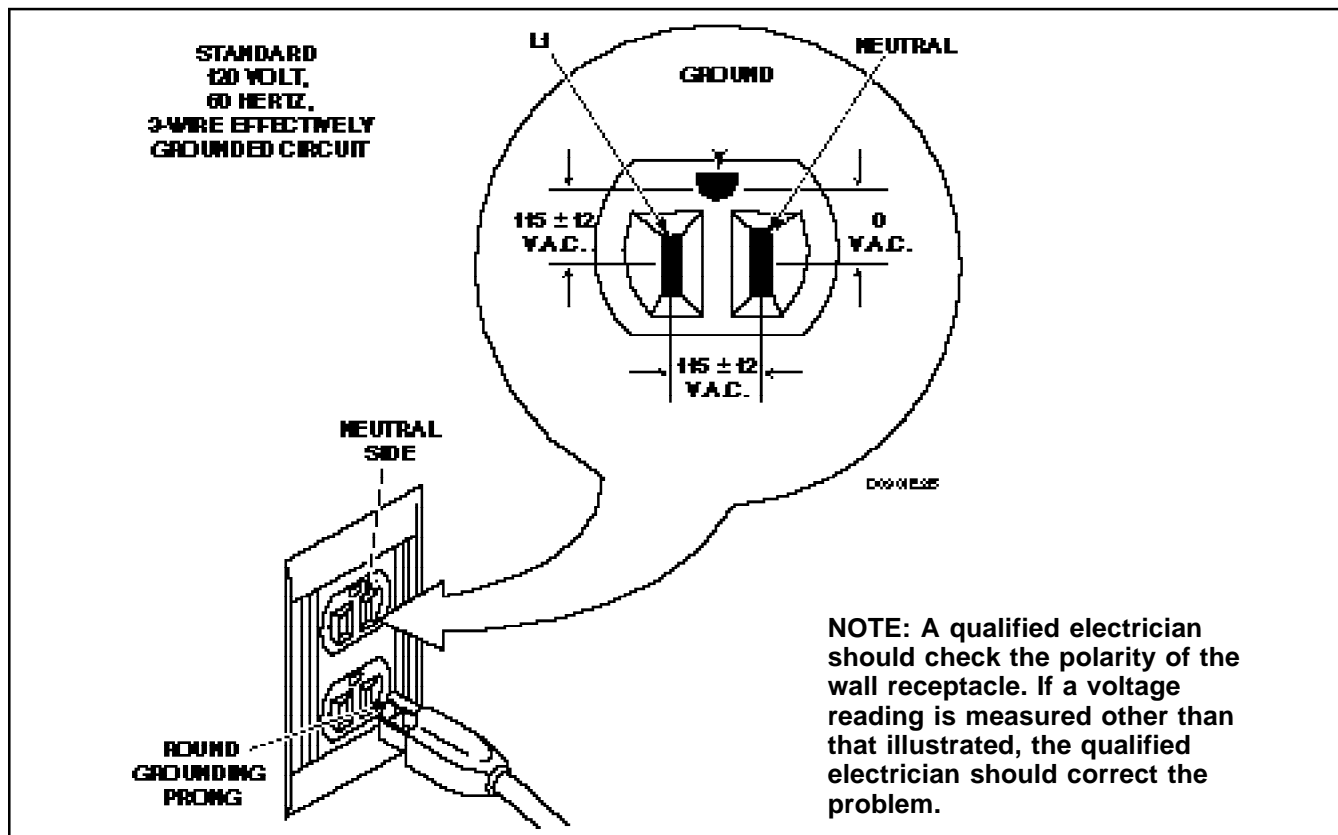

Figure 59

**Electrical Requirements
(Gas Dryers)**

(120 Volt, 60 Hertz, with 3-Prong Grounding Plug)

NOTE: The wiring diagram is located inside the control hood.

a WARNING

To reduce the risk of fire, electric shock or personal injury, all wiring and grounding **MUST** conform with the latest edition of the National Electrical Code, ANSI/NFPA No. 70, and such local regulations as might apply. **IT IS THE CUSTOMER'S RESPONSIBILITY TO HAVE THE WIRING AND FUSES CHECKED BY A QUALIFIED ELECTRICIAN TO MAKE SURE YOUR HOME HAS ADEQUATE ELECTRICAL POWER TO OPERATE THE DRYER.**

- The dryer is designed to be operated on a separate branch, polarized, three-wire, effectively grounded, 120 Volt, 60 Hertz, AC (alternating current), circuit protected by a 15 Ampere fuse, equivalent fuse-tron or circuit breaker.
- The three-prong grounding plug on the power cord should be plugged directly into a polarized three-slot effectively grounded receptacle rated 110/120 Volts AC (alternating current) 15 Amps. See *Figure 63* for determining correct polarity of the wall receptacle.
- **DO NOT OPERATE OTHER APPLIANCES ON THE SAME CIRCUIT. DO NOT OVERLOAD CIRCUITS!** See *Figure 60*.

a WARNING

To reduce the risk of an electric shock or fire, **DO NOT** use an extension cord or an adapter to connect the dryer to the electrical power source.

a WARNING

To reduce the risk of electric shock, fire, explosion, serious injury or death:

- Disconnect electric power to the dryer before servicing.
- Close gas shut-off valve to gas dryer before servicing.
- Never start the dryer with any guards/panels removed.
- Whenever ground wires are removed during servicing, these ground wires must be reconnected to ensure that the dryer is properly grounded.

W001

77. Grounding Instructions

- The dryer must be grounded. In the event of malfunction or breakdown, grounding will reduce the risk of electric shock by providing a path of least resistance for electric current. The dryer is equipped with a cord having an equipment-grounding conductor and a three-prong grounding plug. The plug must be plugged into an appropriate outlet that is properly installed and grounded in accordance with all local codes and ordinances.

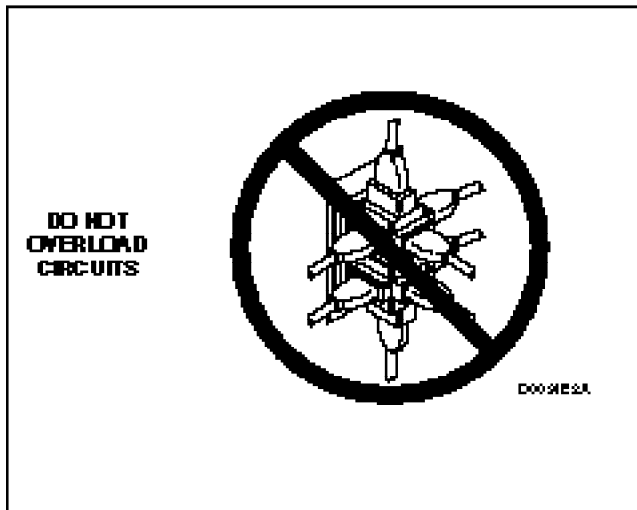

Figure 60

a WARNING

Improper connection of the equipment-grounding conductor can result in a risk of electric shock. Check with a qualified electrician or serviceman if you are in doubt as to whether the dryer is properly grounded.

- DO NOT modify the plug provided with the dryer - if it will not fit the outlet, have a proper outlet installed by a qualified electrician.
- If a positive ground cannot be established through the power cord and if local code permits its use, connect an external ground wire (18 gauge minimum, available at your local hardware store). Connect one end of the wire under the ground screw (located at the rear of the dryer) and the other end to a known effective electrical ground.
- If your home's electrical supply does not meet the above specifications and/or if you are not sure your home has an effective ground, have a qualified electrician or your local electrical utility company check it and correct any problems.

a WARNING

- To reduce the risk of electric shock, fire, explosion, serious injury or death:
- Disconnect electric power to the dryer before servicing.
 - Close gas shut-off valve to gas dryer before servicing.
 - Never start the dryer with any guards/panels removed.
 - Whenever ground wires are removed during servicing, these ground wires must be reconnected to ensure that the dryer is properly grounded.

W001

78. SYMPTOM: FAILURE SYMPTOMS

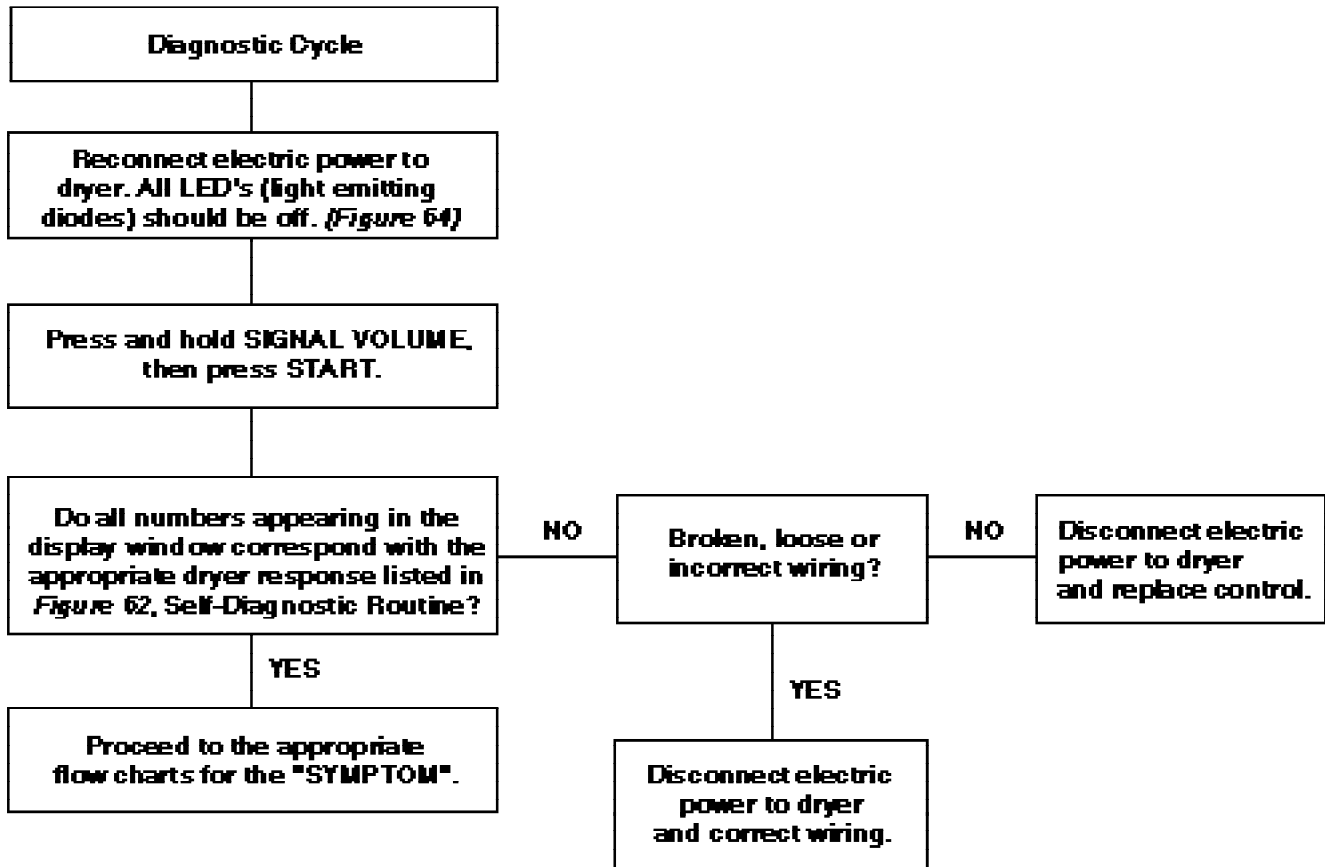

NOTE: The **DIAGNOSTIC** cycle follows the Diagnostic Routine located behind the control hood. All numbers should match with the correct dryer action, see *Figure 62*.

Troubleshooting

NOTE: Refer to *Figure 61*.
If the symptom or problem corresponds to one of the symptoms detailed on the following pages, proceed to that flow chart. (The diagnostic cycle check does not have to be made.)

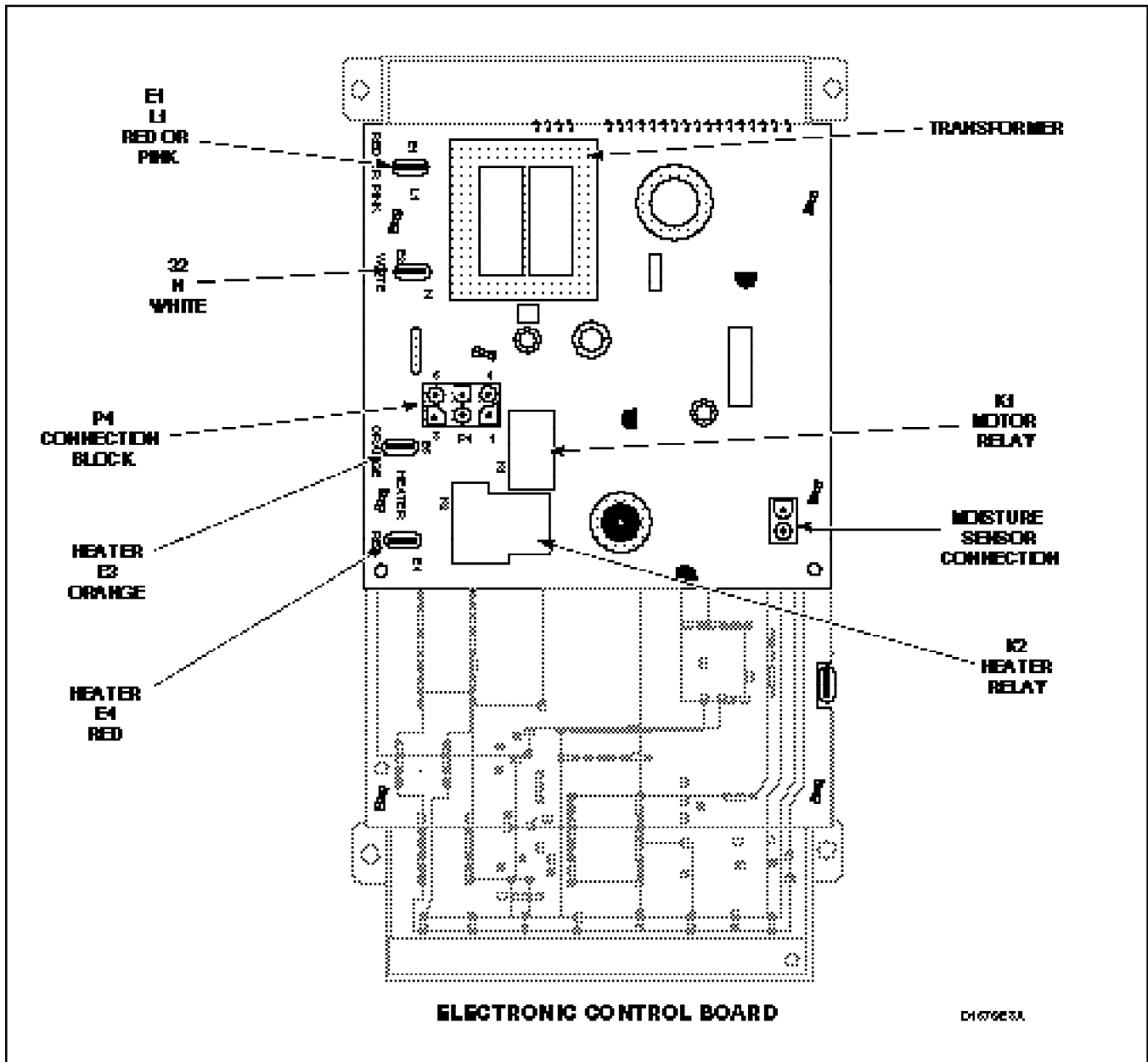

Figure 61

TIME DISPLAY	ILLUMINATED LED'S / VFD	MOTOR RELAY	HEATER RELAY	SIGNAL
11	ALL ON	ON	OFF	OFF
12	ALL OFF	ON	ON	OFF
33	ALL ON	ON	ON	OFF
44	ALL ON	ON	ON	OFF
55	ALL OFF	OFF	OFF	LOWEST
66	ALL ON	OFF	OFF	MEDIUM
77	ALL OFF	OFF	OFF	LOUDEST

NOTE:

1. This test routine will only light in the LED's (Figure 64) pertaining to the hardware model selected.
2. When the last step in the table is finished, the routine sequence will repeat.
3. Each output is on for two seconds.

DIAGNOSTIC ROUTINE

Figure 62

a WARNING

- To reduce the risk of electric shock, fire, explosion, serious injury or death:
- Disconnect electric power to the dryer before servicing.
 - Close gas shut-off valve to gas dryer before servicing.
 - Never start the dryer with any guards/panels removed.
 - Whenever ground wires are removed during servicing, these ground wires must be reconnected to ensure that the dryer is properly grounded.

W001

79. SYMPTOM: BLOWN FUSE OR TRIPPED CIRCUIT BREAKER.

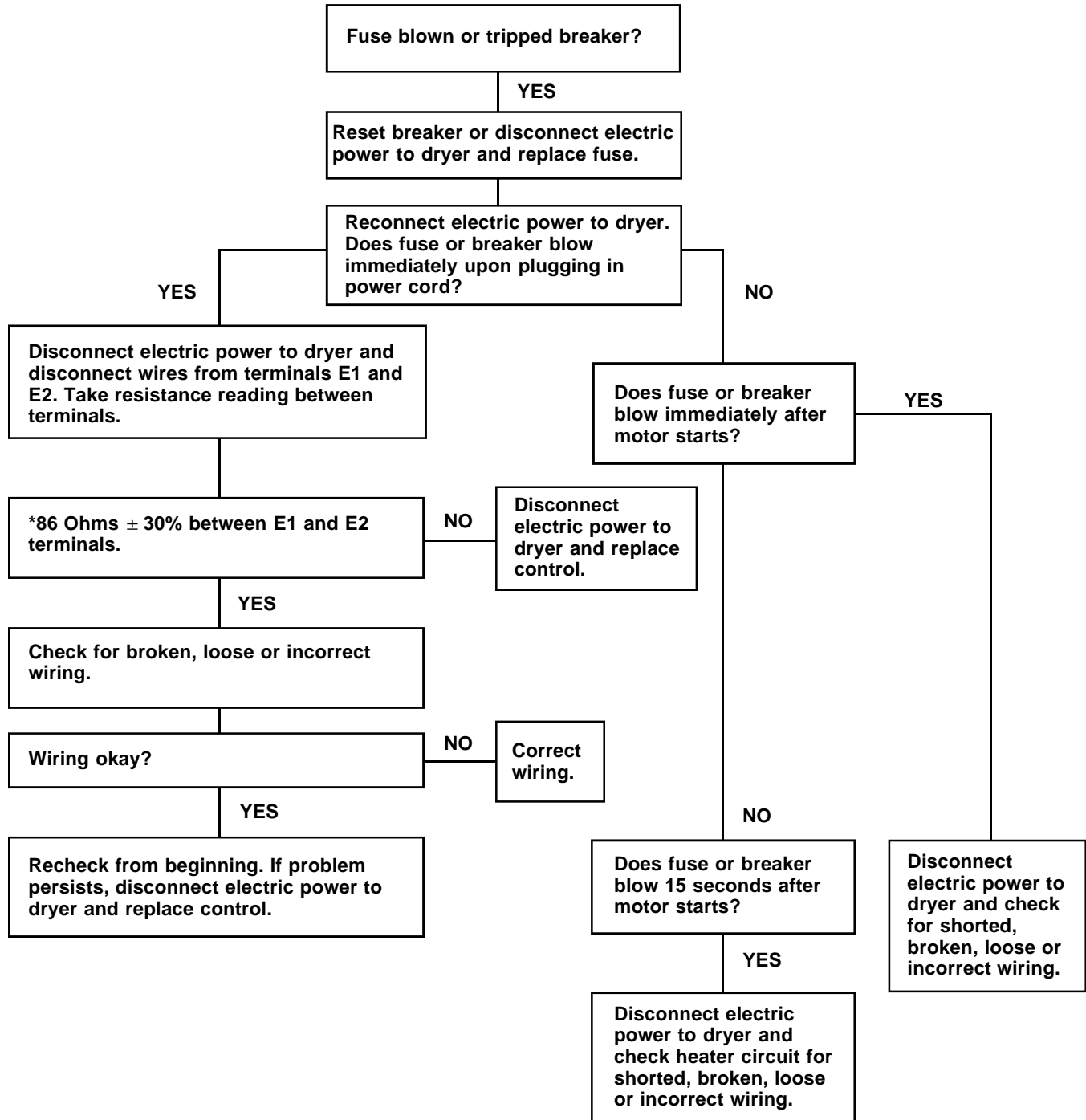

*This measurement should be made with a digital Multi-Meter set at 200 Ohm scale for best accuracy.

a WARNING

To reduce the risk of electric shock, fire, explosion, serious injury or death:

- Disconnect electric power to the dryer before servicing.
- Close gas shut-off valve to the dryer before servicing.
- Never start the dryer with any guards/panels removed.
- Whenever ground wires are removed during servicing, these ground wires must be reconnected to ensure that the dryer is properly grounded.

W001

80. SYMPTOM: CONTROL WILL NOT WAKE UP (No LED's Light) AFTER SELECT CYCLE PAD IS PRESSED.

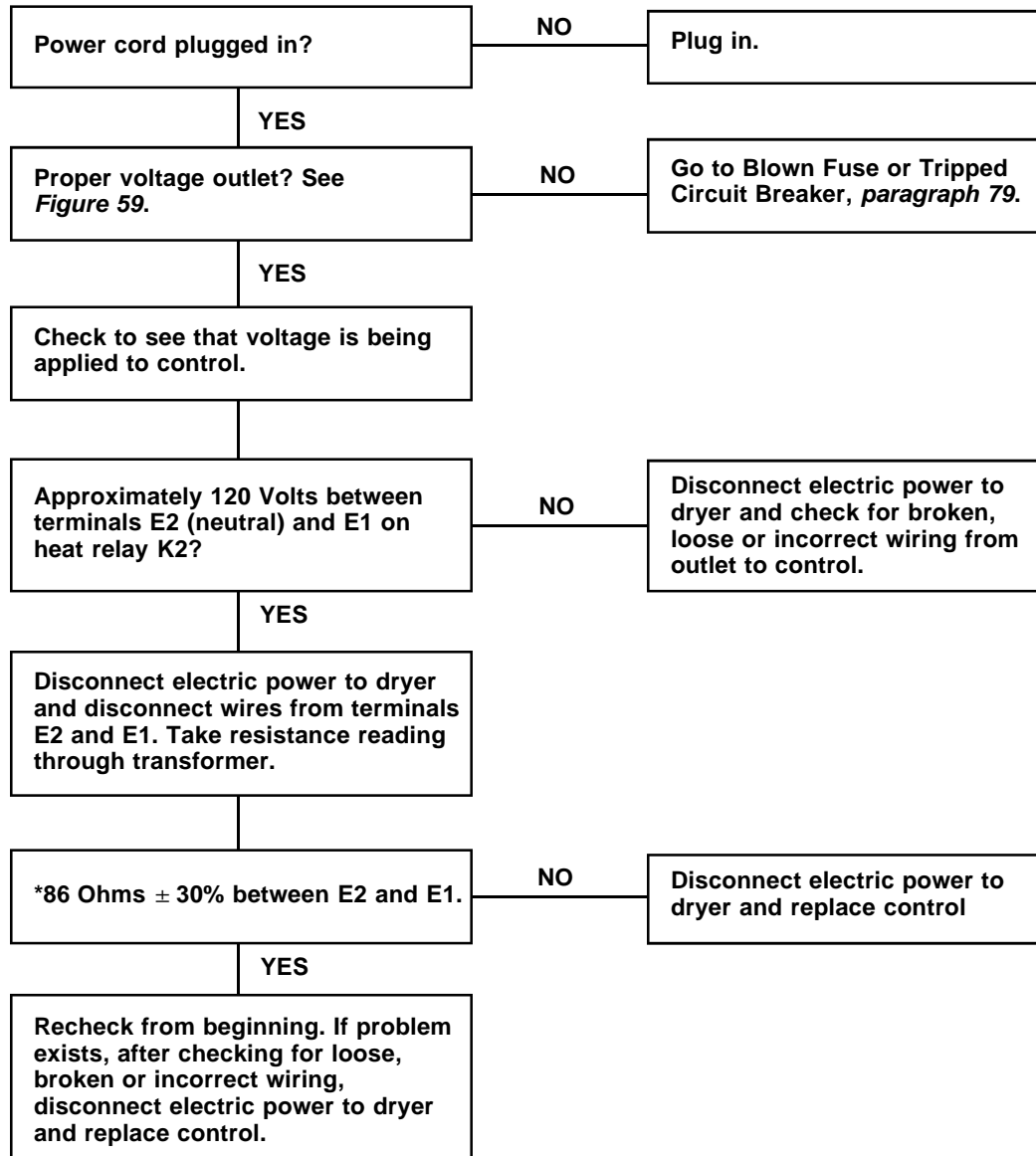

***This measurement should be made with a digital Multi-Meter set at 200 Ohm scale for best accuracy.**

a WARNING

To reduce the risk of electric shock, fire, explosion, serious injury or death:

- Disconnect electric power to the dryer before servicing.
- Close gas shut-off valve to gas dryer before servicing.
- Never start the dryer with any guards/panels removed.
- Whenever ground wires are removed during servicing, these ground wires must be reconnected to ensure that the dryer is properly grounded.

W001

81. SYMPTOM: CONTROL WAKES UP (When SELECT CYCLE Pad is Pressed) BUT MOTOR DOES NOT START PROPERLY. CONTROL MAY INDICATE DOOR OPEN ON DISPLAY WITH DOOR CLOSED. HOWEVER, THE FOLLOWING CHECKS STILL NEED TO BE MADE TO ISOLATE THE PROBLEM.

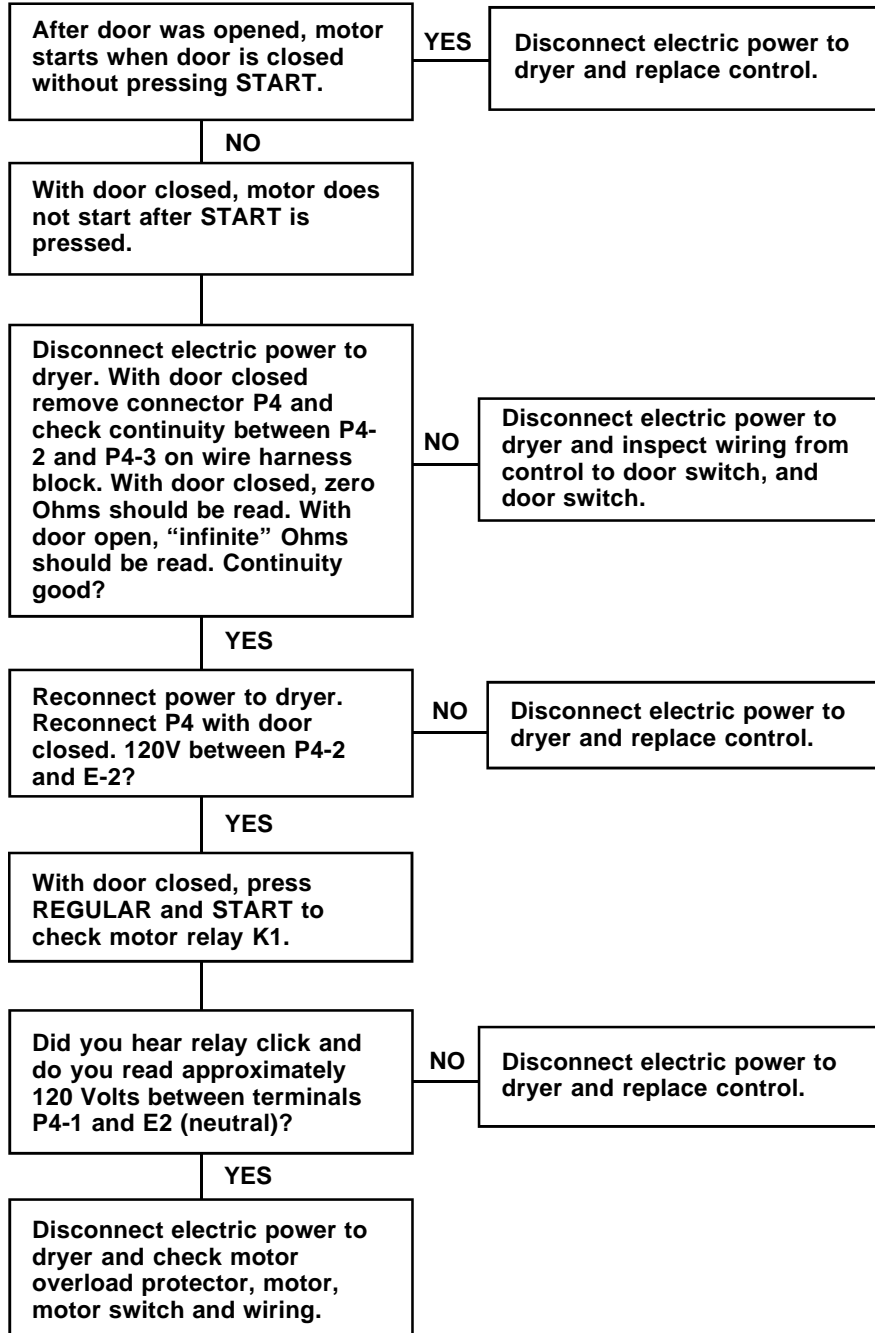

a WARNING

To reduce the risk of electric shock, fire, explosion, serious injury or death:

- Disconnect electric power to the dryer before servicing.
- Close gas shut-off valve to the dryer before servicing.
- Never start the dryer with any guards/panels removed.
- Whenever ground wires are removed during servicing, these ground wires must be reconnected to ensure that the dryer is properly grounded.

W001

82. SYMPTOM: HEATER DOES NOT TURN ON OR NO HEAT.

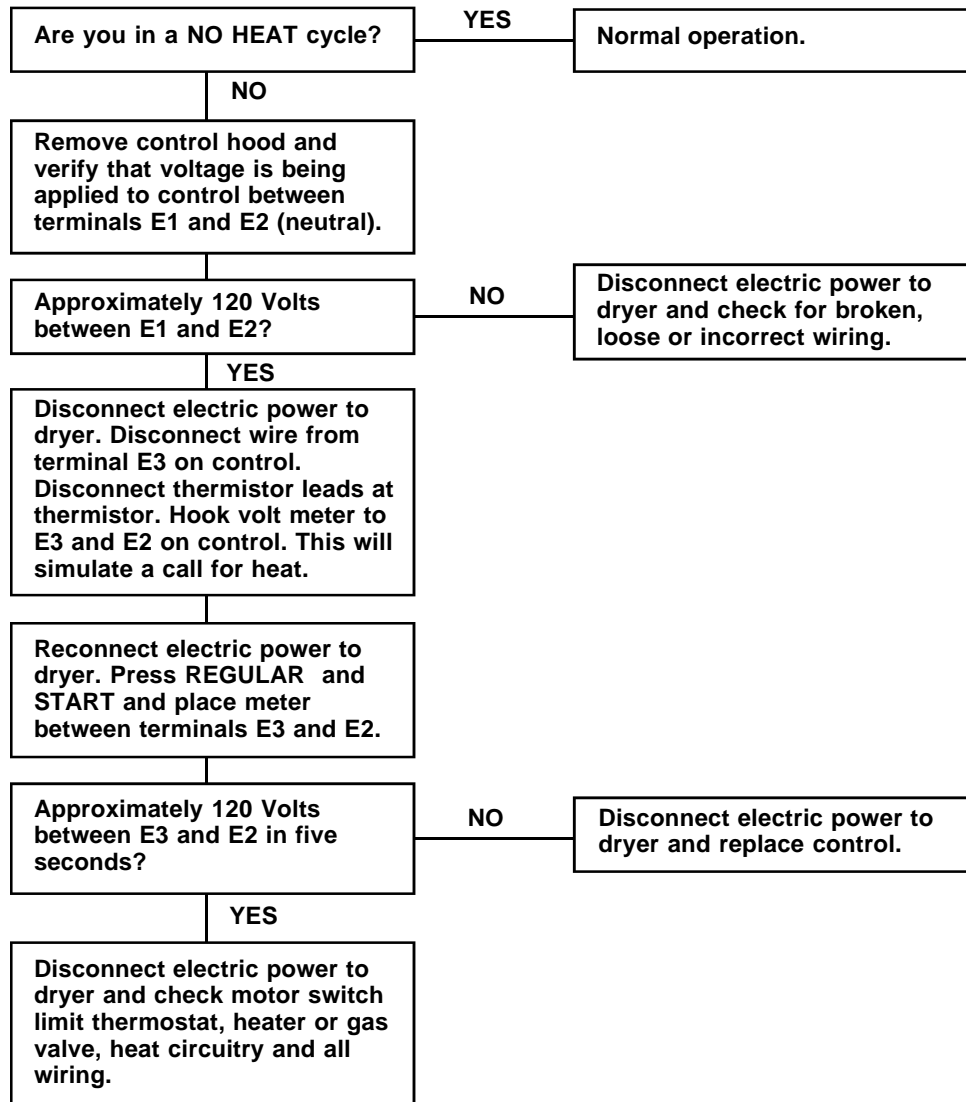

a WARNING

- To reduce the risk of electric shock, fire, explosion, serious injury or death:
- Disconnect electric power to the dryer before servicing.
 - Close gas shut-off valve to gas dryer before servicing.
 - Never start the dryer with any guards/panels removed.
 - Whenever ground wires are removed during servicing, these ground wires must be reconnected to ensure that the dryer is properly grounded.

W001

83. SYMPTOM: IMPROPER DRYING TEMPERATURE OR DRY TIMES.

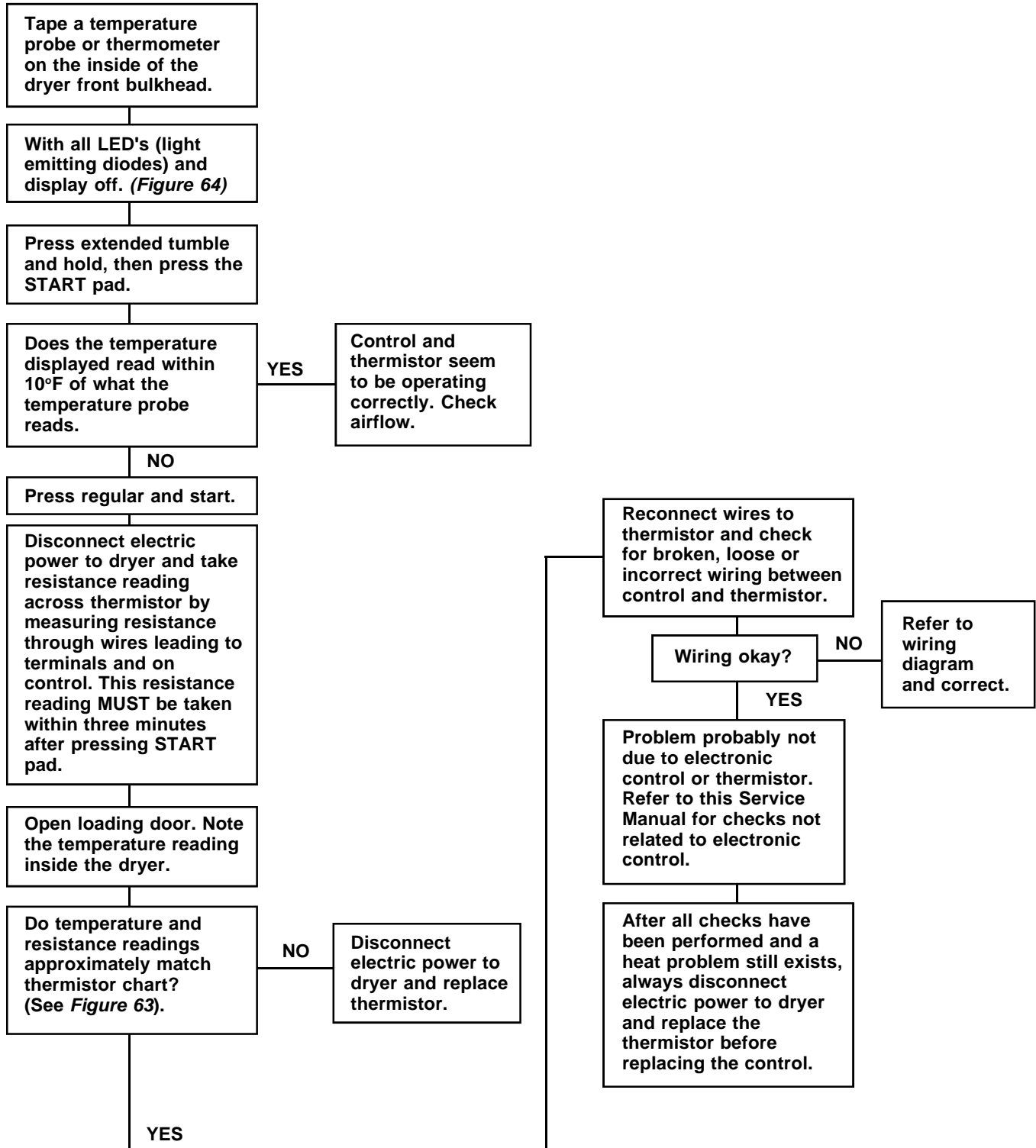

Thermistor Chart					
Temp. °F	Resistance Ohms	Temp. °F	Resistance Ohms	Temp. °F	Resistance Ohms
-20	826000	55	87200	125	16900
-15	697000	60	76600	130	15200
-10	590500	65	67350	135	13800
- 5	501500	70	59400	140	12400
0	427000	75	52500	145	11300
5	364800	77	50000	150	10200
10	312500	80	46500	155	9300
15	268400	85	41300	160	8400
20	231200	90	36700	165	7700
25	199600	95	32700	170	7000
30	172800	100	29100	175	6400
35	150000	105	26100	180	5900
40	130500	110	23300	185	5400
45	113800	115	20900	190	4900
50	99500	120	18800	195	4500

Figure 63

a WARNING

To reduce the risk of electric shock, fire, explosion, serious injury or death:

- Disconnect electric power to the dryer before servicing.
- Close gas shut-off valve to gas dryer before servicing.
- Never start the dryer with any guards/panels removed.
- Whenever ground wires are removed during servicing, these ground wires must be reconnected to ensure that the dryer is properly grounded.

W001

84. SYMPTOM: "oP" APPEARS IN TIME DISPLAY

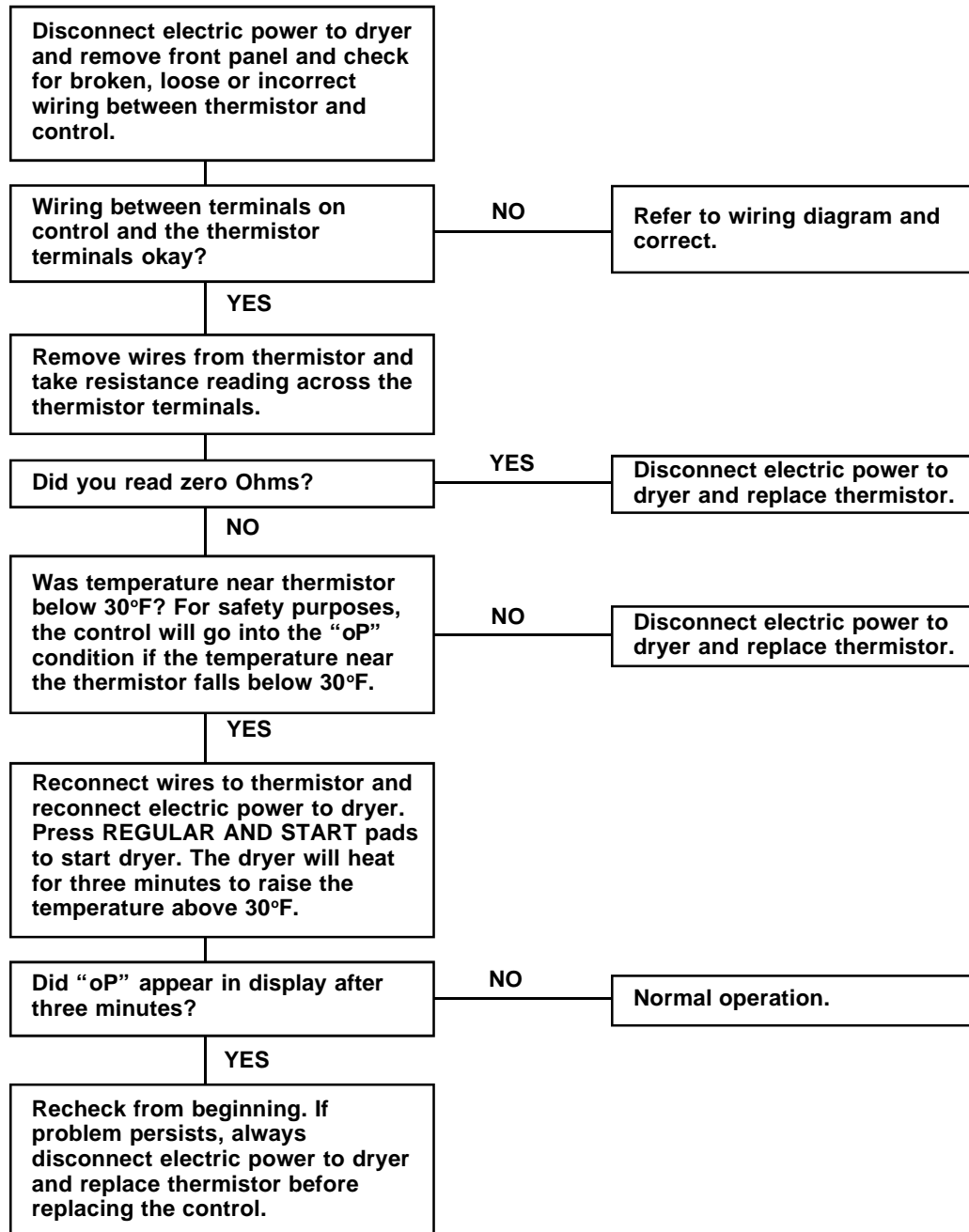

a WARNING

To reduce the risk of electric shock, fire, explosion, serious injury or death:

- Disconnect electric power to the dryer before servicing.
- Close gas shut-off valve to the dryer before servicing.
- Never start the dryer with any guards/panels removed.
- Whenever ground wires are removed during servicing, these ground wires must be reconnected to ensure that the dryer is properly grounded.

W001

85. SYMPTOM: "SH" APPEARS IN TIME DISPLAY

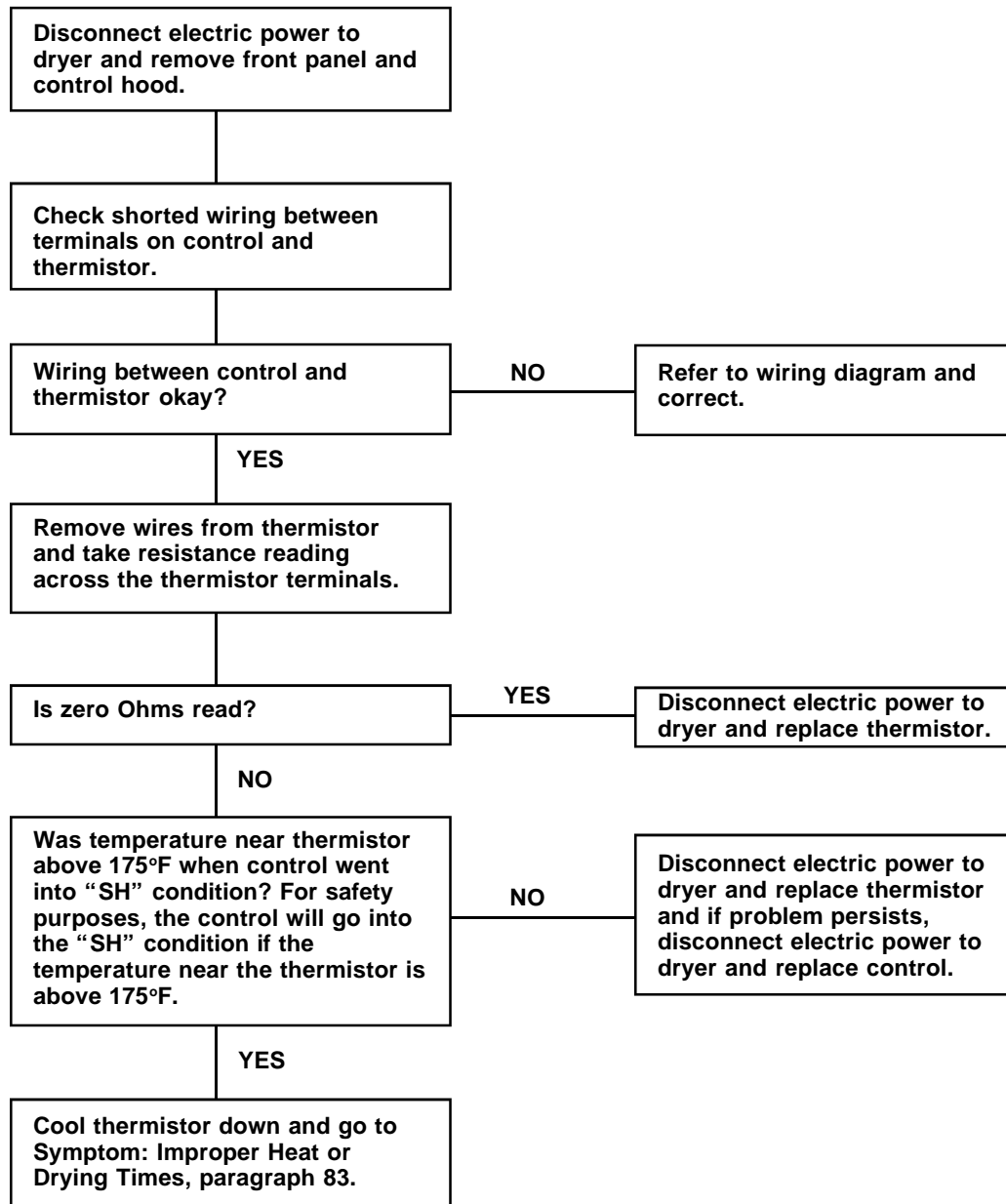

a WARNING

To reduce the risk of electric shock, fire, explosion, serious injury or death:

- Disconnect electric power to the dryer before servicing.
- Close gas shut-off valve to the dryer before servicing.
- Never start the dryer with any guards/panels removed.
- Whenever ground wires are removed during servicing, these ground wires must be reconnected to ensure that the dryer is properly grounded.

W001

86. SYMPTOM: DRYER GOES INTO COOL-DOWN IN ABOUT FIVE MINUTES AND LOAD IS NOT DRY.

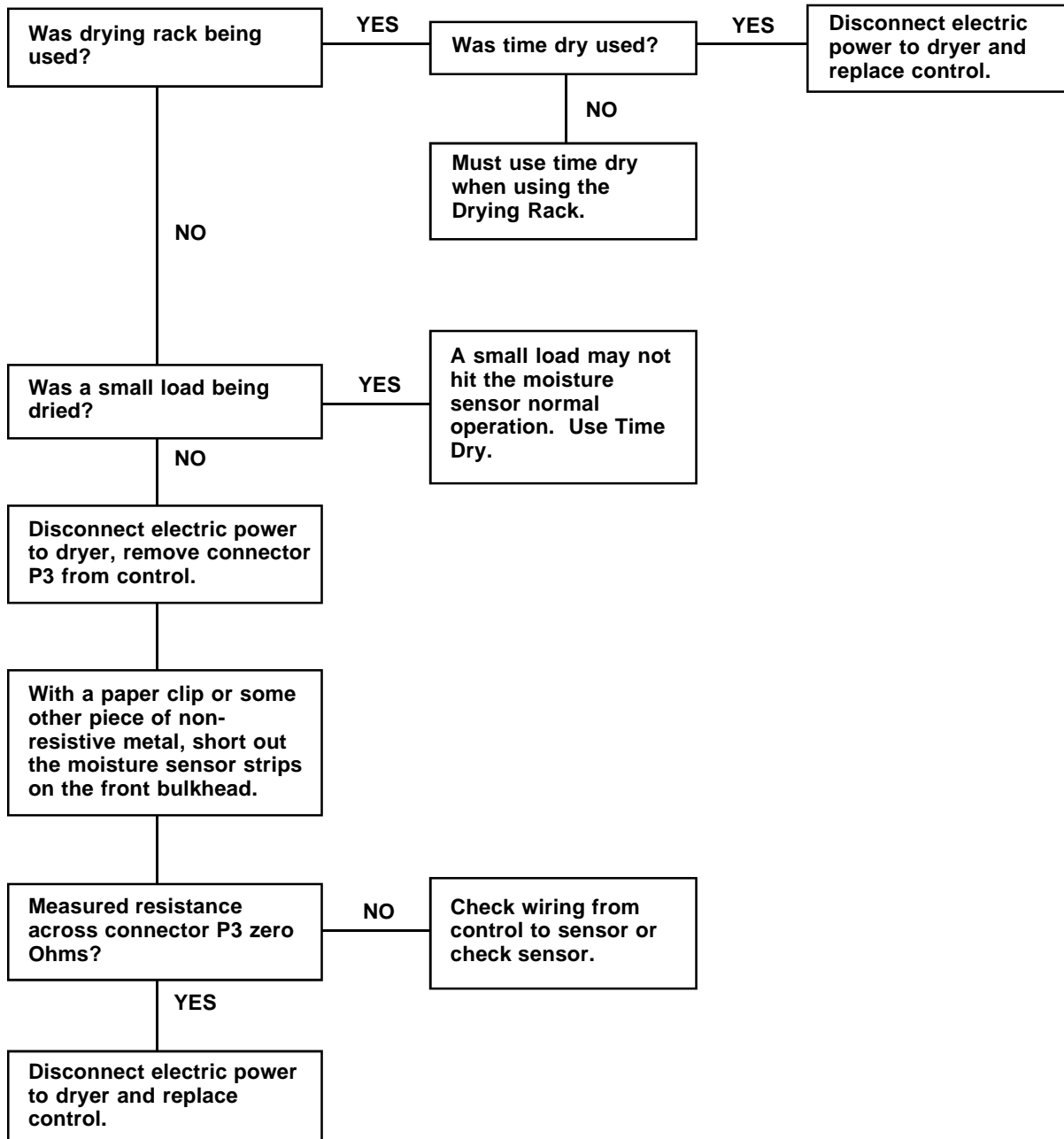

a WARNING

To reduce the risk of electric shock, fire, explosion, serious injury or death:

- Disconnect electric power to the dryer before servicing.
- Close gas shut-off valve to gas dryer before servicing.
- Never start the dryer with any guards/panels removed.
- Whenever ground wires are removed during servicing, these ground wires must be reconnected to ensure that the dryer is properly grounded.

W001

87. CONTROL REPLACEMENT (Figure 64)

When a problem with the electronic control is detected during the diagnostic cycle, or while making the electrical tests we have discussed, the control is replaced as a complete unit. Due to the sensitivity of the electronic control, careful handling is required. As a precautionary measure, we recommend the use of a grounded wrist strap when handling the electronic controls. The wrist strap, cord and alligator clip are designed to carry away any electrostatic charge from your body and to direct the charge to an available ground. By using this static protection device, potential electrostatic discharge problems associated with the handling of the electronic control will be minimized. Always handle the electronic control by the metal edges. If a wrist strap is not available, touch the dryer while it is plugged in before handling the control to dissipate any charge.

To replace the control, first unplug the dryer. Remove all of the wires connected to the control and take out the screws securing the control to the control hood. When removing wires from the control, hold down on the board near the appropriate terminal, and disconnect the wires using a pliers. Do not pull on wires.

The new control is supplied in a special anti-static wrapping, and protected by anti-static foam. While holding the metal edges, remove the control from the foam and the wrapping. Lift the inoperative control off the mounting bracket and place it on the anti-static wrapping. Before positioning the new control in the control hood, peel off the protective plastic coating from the front side of the control, then fasten the control down with the screws. Following the wiring diagram, reconnect the wires to the new control, then replace the control hood.

IMPORTANT: Take care when handling the original control. It must be carefully placed in the anti-static wrapping and the anti-static foam which was removed from the new control. A copy of the replacement report, shown on Page 87, must be completely filled out and returned with the control. Warranty credit will not be issued if the control is not wrapped properly.

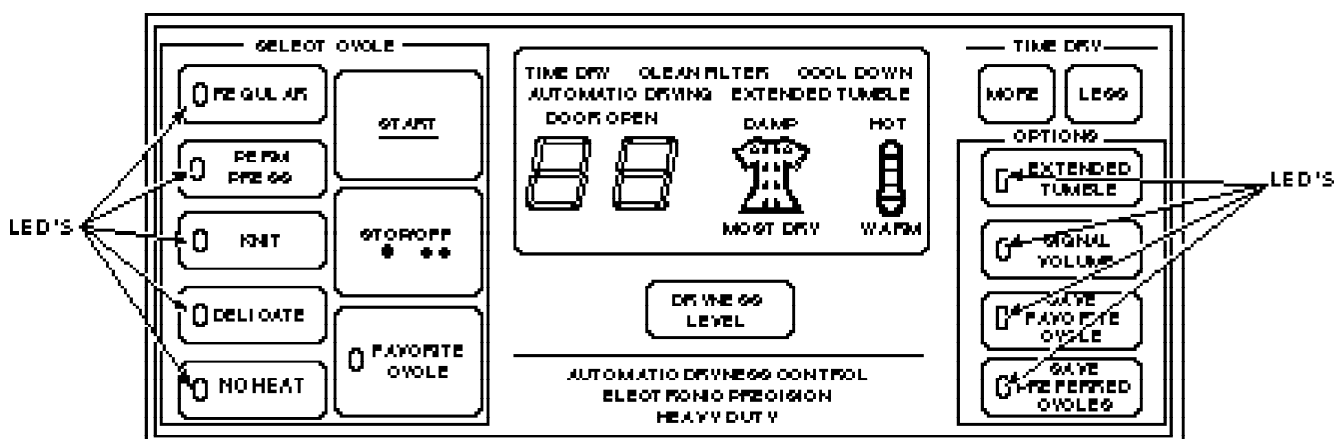

Figure 64

Electronic Control Board Replacement Report

Installation Date: _____

Date Failed: _____

Model No. _____

Serial No.: _____

Service Company Identification No.: _____

1. What was the customer's complaint?

2. Mark the cause of the complaint in the appropriate box below:

Washer Control Failure

Failure in Diagnostic Cycle

Transformer:

Resistance not in 60-100 Ohm range between E1 and E2?

Hot Water Relay K5:

120 Volts not found between P4-1 and E2 in hot fill?

Cold Water Relay K6:

120 Volts not found between P4-4 and E2 in cold fill?

Speed Relay K2:

120 Volts not found between E2 and P3-5 in low speed?

120 Volts not found between E2 and P3-4 in high speed?

Agitation Relay K3:

120 Volts not found between P3-3 and E2 in agitation?

120 Volts found between P3-3 and E2 in spin?

Spin Relay K3:

120 Volts not found between P3-1 and E2 during spin?

120 Volts found between P3-1 and E2 during agitation?

Ambient temperature is not what control shows in temperature diagnostics. (Allow washer to return to room temperature before running diagnostics.)

Dryer Control Failure

Failure in Diagnostic Cycle

Transformer:

Resistance not in 60-100 Ohm range between E1 and E2?

Motor Relay K1:

120 Volts not found between P4-1 and E2.?

Heat Relay K2:

With E3 disconnected, 120 Volts not found between E3 and E2?

Temperature Regulating Circuit:

"SH" appears in the display window when the exhaust temperature is less than 175°F?

"OP" appears in display window when the dryer has heated for three minutes.

Ambient temperature is not what control shows in temperature diagnostics. (Allow dryer to return to room temperature before running diagnostics.)

Dryer Moisture Sensor Control Failure

Timer Motor Relay K702:

120 Volts not found between "M" and "T"?

Heat Relay K701:

120 Volts not found between "E2" and "E3"?

Temperature Regulating Circuit:

Timer, thermistor, moisture sensor and Temp/dryness control are functioning and work correctly.

Both copies of this form must be completed and returned with the control board.

Warranty is void if control board is returned improperly packed or damaged.

SECTION VIII

Service Procedures Unique to the Electromechanical Dryers with Moisture Sensor

a WARNING

To reduce the risk of electric shock, fire, explosion, serious injury or death:

- Disconnect electric power to the dryer before servicing.
- Close gas shut-off valve to gas dryer before servicing.
- Never start the dryer with any guards/panels removed.
- Whenever ground wires are removed during servicing, these ground wires must be reconnected to ensure that the dryer is properly grounded.

W001

88. DRYER OPERATION

Select TIMER setting in cycle desired:
AUTOMATIC PERMANENT PRESS/KNITS,
AUTOMATIC REGULAR, AUTOMATIC
DELICATE, TIME DRY, or NO HEAT.

The AUTOMATIC cycles control the temperature and drying time. The TIME DRY cycle temperature is controlled by the TEMP/ DRYNESS control.

Push the TIMER knob to start dryer.

TO STOP DRYER AT ANY TIME: Open the dryer door.

89. AUTOMATIC CYCLES

The AUTOMATIC CYCLES will determine the time needed by use of a moisture sensor located below the lint screen (*Figure 41*) and a thermistor.

The TEMP/DRYNESS control should be set just to the right of MED/NORMAL.

90. NO HEAT

This cycle will tumble and circulate room temperature air through the load. Use for any items that should not be dried with heat.

Set TIMER for length of time desired.

91. TIME DRY

The TIME DRY cycle will operate the dryer for the number of minutes set by the user. In this cycle, the temperature is set by the TEMP/ DRYNESS control.

a WARNING

To reduce the risk of electric shock, fire, explosion, serious injury or death:

- Disconnect electric power to the dryer before servicing.
- Close gas shut-off valve to the gas dryer before servicing.
- Never start the dryer with any guards/panels removed.
- Whenever ground wires are removed during servicing, these ground wires must be reconnected to ensure that the dryer is properly grounded.

W001

92. CONTROL REPLACEMENT

See *paragraph 93* on handling of electronic parts, both new and those to be returned.

Disconnect electric power to dryer. Remove control hood per instructions in *paragraph 5-13*. Carefully remove connectors at P1, H3 and E1 through E3 on the control, *Figure 65*.

Working on one corner of the PC board at a time, depress the locking tab on the plastic stand-off with a needle nose pliers and lift that corner free.

The new control is supplied in an anti-static bag and protected by anti-static packaging. Carefully remove control from packaging and bag and snap into place on the stand-offs. Re-connect P1, H3, and E1 through E3, *Figure 64*.

Re-install control hood and supply power to the dryer. Verify operation per *paragraph 5-13*.

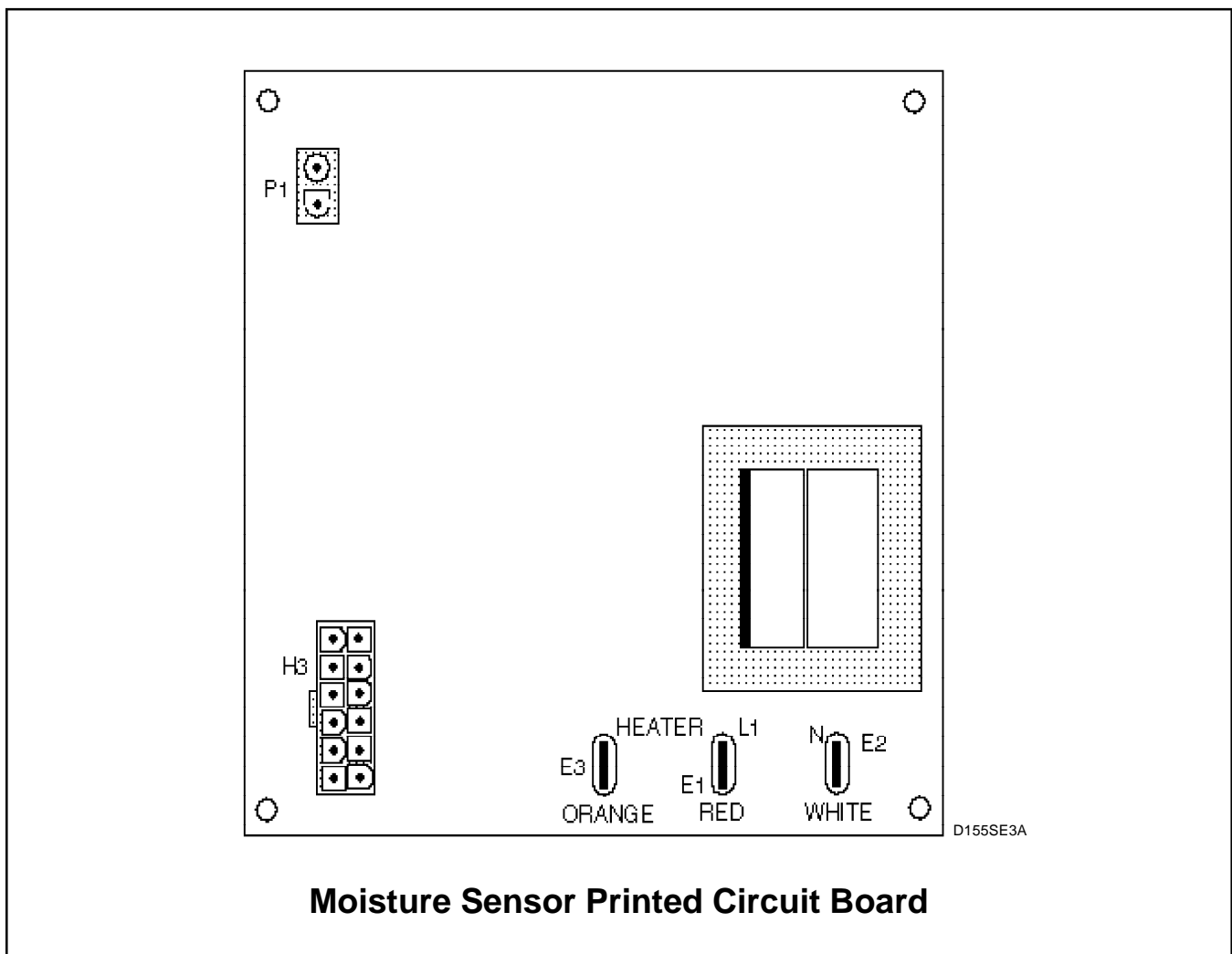

Moisture Sensor Printed Circuit Board

Figure 65

93. TIMER CONTACT POINTS.

CIRCUIT TO BE TESTED	CONTACTS
Timer Motor	L1 and M
Main Motor	L1 and M
Signal Control	S and BZ
Auto Regular	DC and C
Auto Perm Press	DC and B
Auto Delicate	DC & B & C
Cool-Down	DC & A
Time Dry	DC & A & B
Push-to-Start	M and S

Figure 66

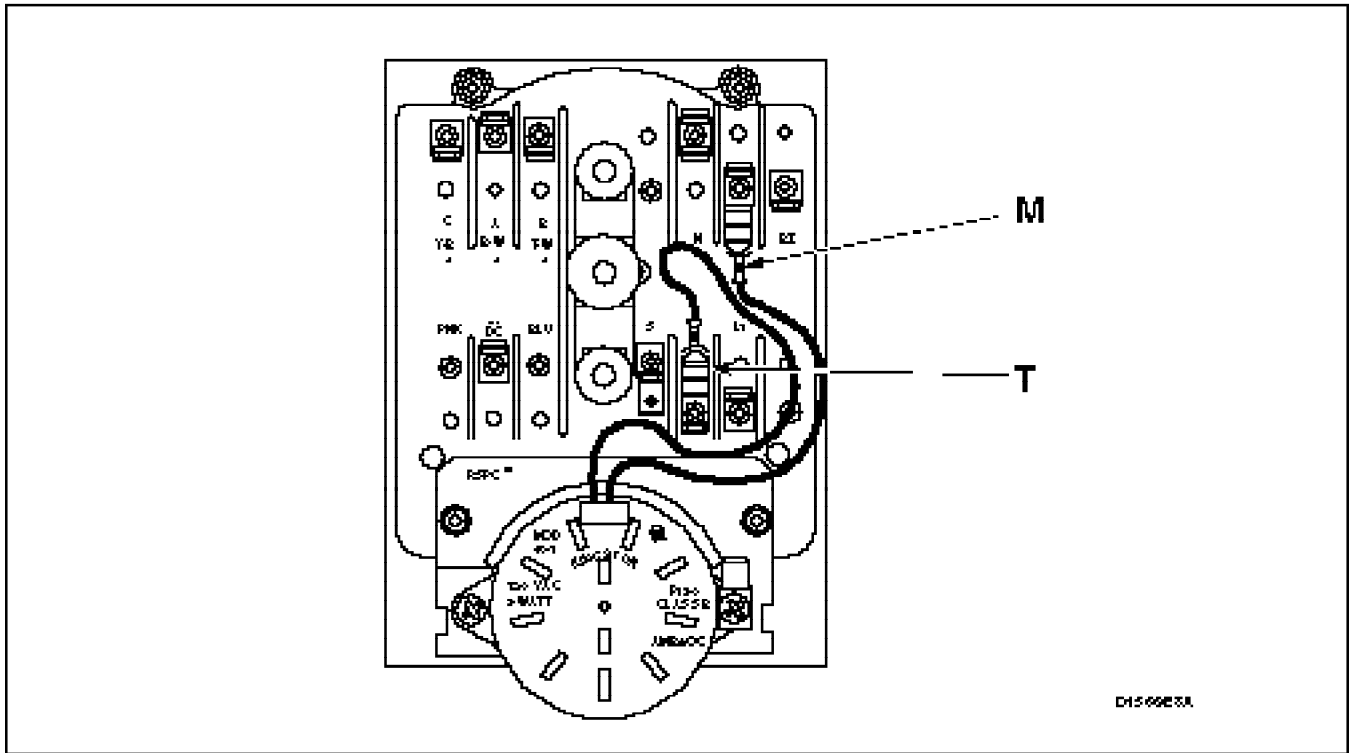

Figure 67

94. TEMP/DRYNESS CONTROL RESISTANCE CHART

POTENTIOMETER (OHMS)	AUTOMATIC SETTINGS	TIME DRY TEMP °F
0	DAMP	110
70	DAMP	112
140	DAMP	114
210	DAMP	116
280	DAMP	118
350	DAMP	120
420	DAMP	122
490	DAMP	124
560	NORMAL	126
800	NORMAL	128
940	NORMAL	130
1100	NORMAL	131
1260	NORMAL	132
1420	NORMAL	133
1580	NORMAL	134
1800	NORMAL	135
1900	EXTRA DRY	136
2165	EXTRA DRY	137
2390	EXTRA DRY	138
2615	EXTRA DRY	139
2840	EXTRA DRY	140
3065	EXTRA DRY	141
3290	EXTRA DRY	142
3500	EXTRA DRY	143
4000	MOST DRY	144
5000	MOST DRY	145
6000	MOST DRY	146
7000	MOST DRY	147
8000	MOST DRY	148
9000	MOST DRY	149
10000	MOST DRY	150

NOTE: Resistance measurements taken with potentiometer disconnected from harness.

Figure 68

a WARNING

To reduce the risk of electric shock, fire, explosion, serious injury or death:

- Disconnect electric power to the dryer before servicing.
- Close gas shut-off valve to gas dryer before servicing.
- Never start the dryer with any guards/panels removed.
- Whenever ground wires are removed during servicing, these ground wires must be reconnected to ensure that the dryer is properly grounded.

W001

95. SYMPTOM: TIMER DOES NOT ADVANCE.

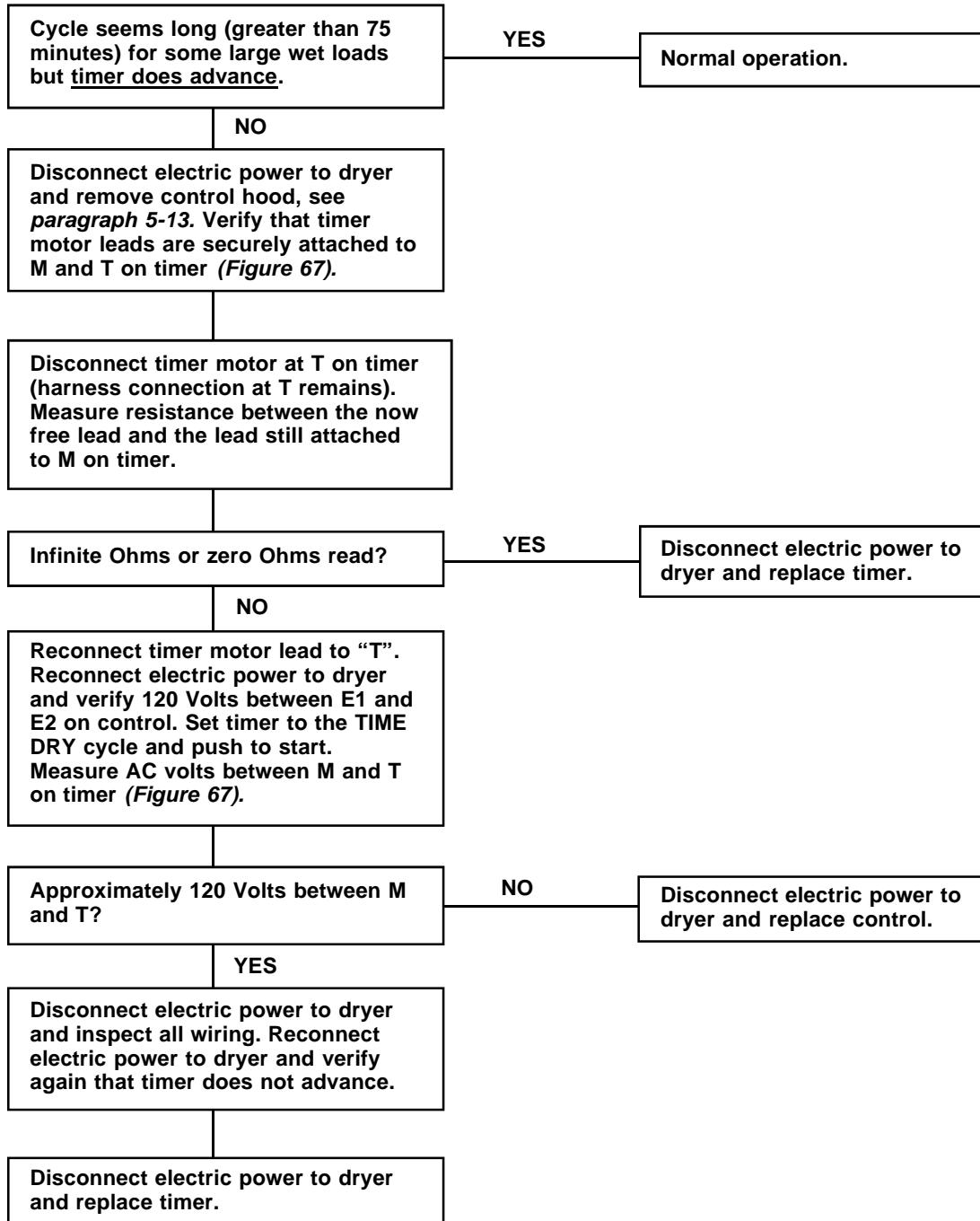

a WARNING

- To reduce the risk of electric shock, fire, explosion, serious injury or death:
- Disconnect electric power to the dryer before servicing.
 - Close gas shut-off valve to gas dryer before servicing.
 - Never start the dryer with any guards/panels removed.
 - Whenever ground wires are removed during servicing, these ground wires must be reconnected to ensure that the dryer is properly grounded.

W001

96. SYMPTOM: HEATER DOES NOT TURN ON OR NO HEAT.

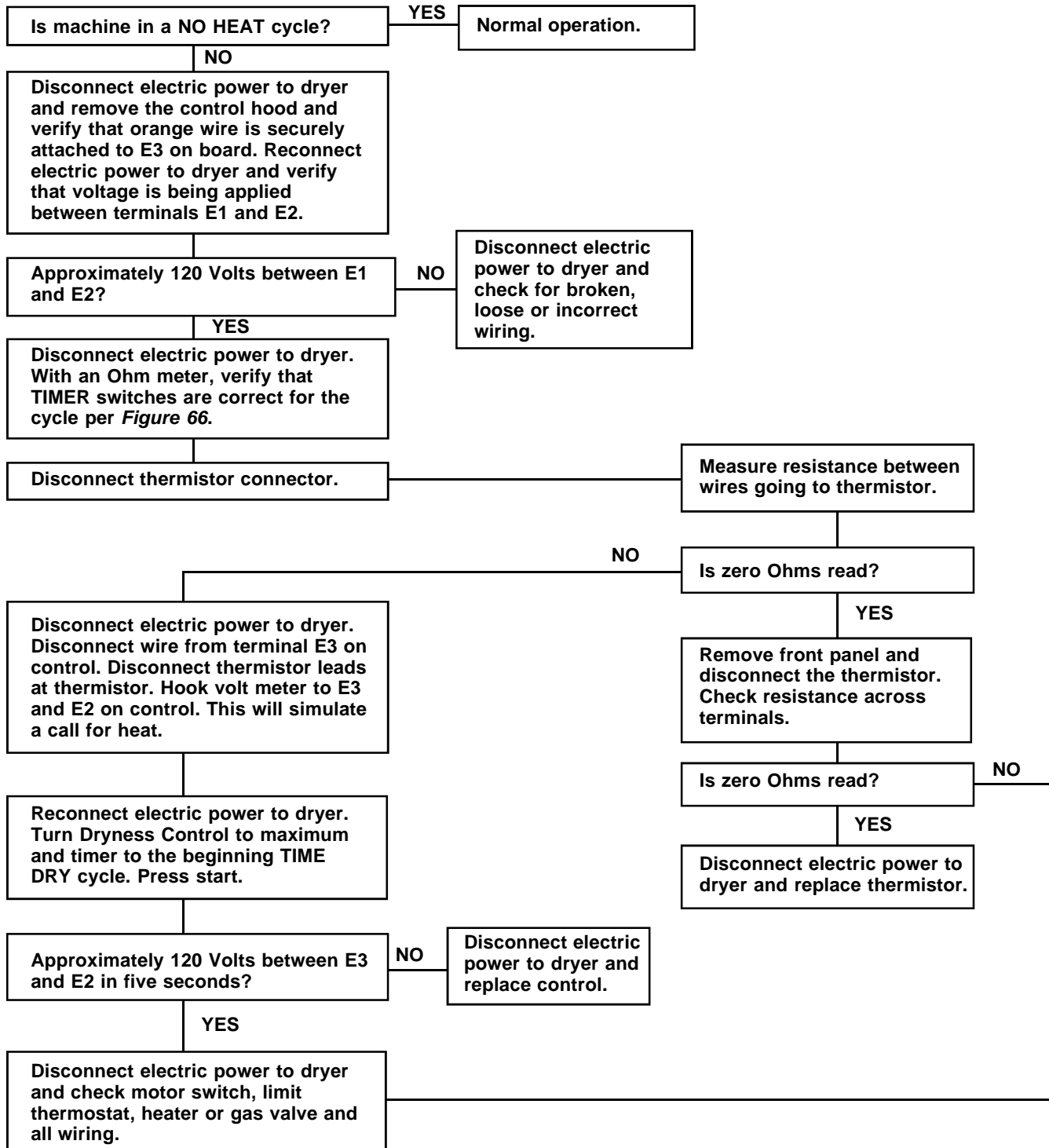

a WARNING

- To reduce the risk of electric shock, fire, explosion, serious injury or death:
- Disconnect electric power to the dryer before servicing.
 - Close gas shut-off valve to the dryer before servicing.
 - Never start the dryer with any guards/panels removed.
 - Whenever ground wires are removed during servicing, these ground wires must be reconnected to ensure that the dryer is properly grounded.

W001

97. SYMPTOM: HEATER ASSEMBLY OR BURNER SHUTS OFF PREMATURELY. (Load does not dry.)

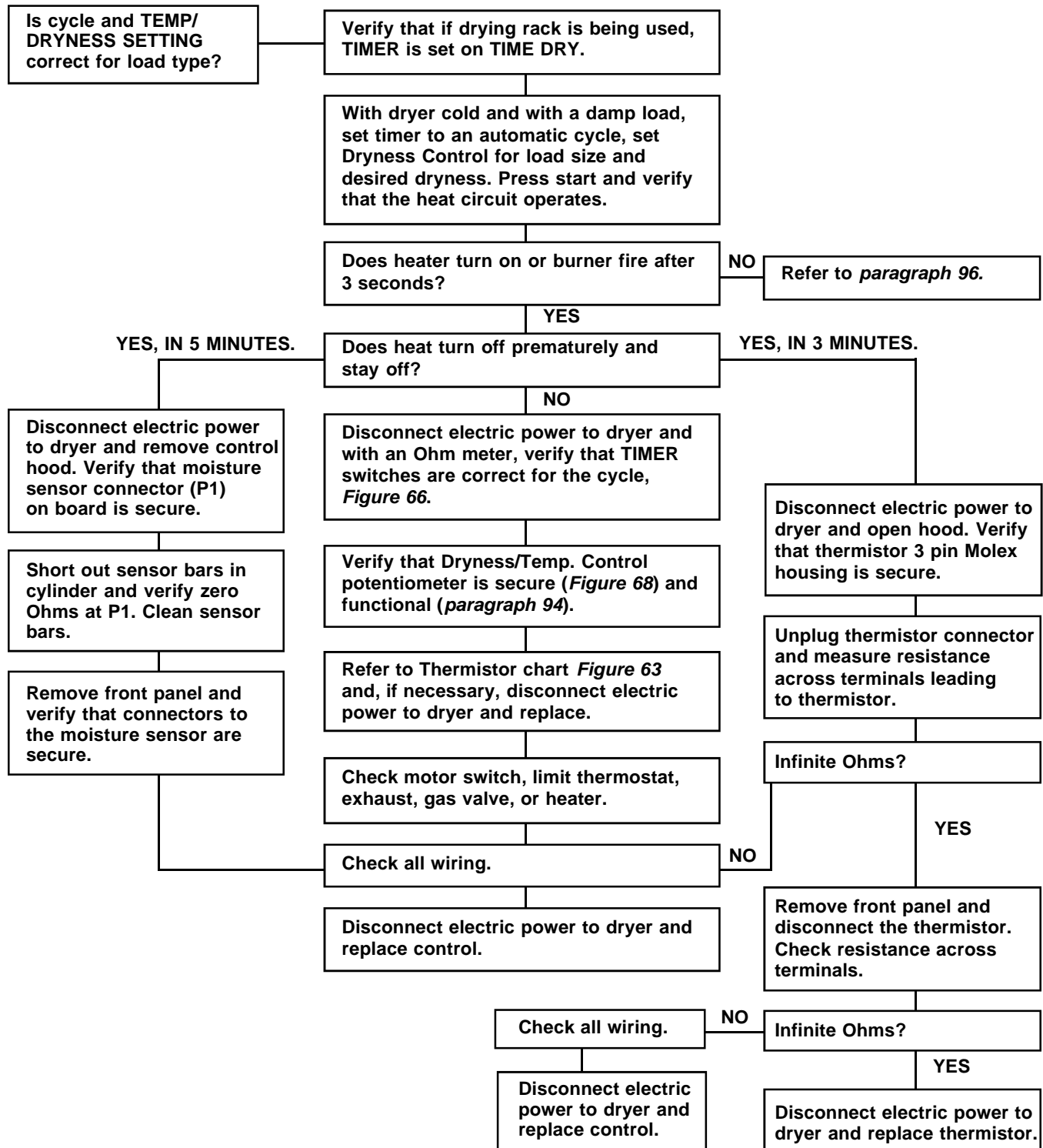

a WARNING

To reduce the risk of electric shock, fire, explosion, serious injury or death:

- Disconnect electric power to the dryer before servicing.
- Close gas shut-off valve to the dryer before servicing.
- Never start the dryer with any guards/panels removed.
- Whenever ground wires are removed during servicing, these ground wires must be reconnected to ensure that the dryer is properly grounded.

W001

98. SYMPTOM: CLOTHES ARE TOO HOT WHEN REMOVED FROM DRYER.

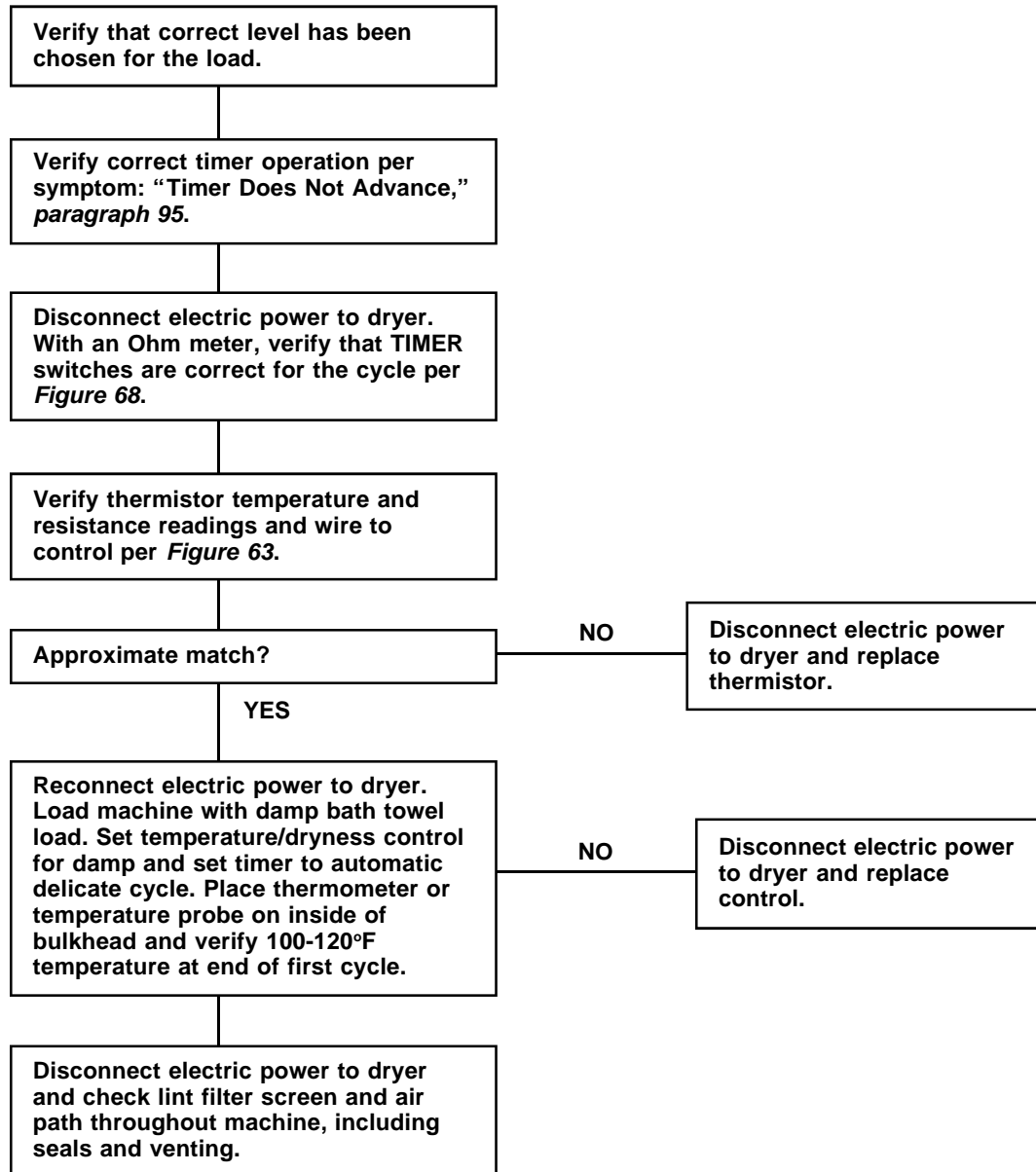

SECTION IX

Wiring Diagrams

No. 501414R1

Models LE7121*M, LE7153*B, LE7153*M, LE7163*M and LE8457*2

No. 500728

Models LE8407*2, LE8517*2 and LE8567*2

No. 500727r3

Model LE8607*2

No. 500737R2

Model LE9207*2

No. 501888r2

Models LG4209*2, LG8209*2, LG8209*3, LG8109*2 and LG8101*B

No. 500705R2

Models LG4319*2, LG8111*B, LG8111*M and LG8319*2

No. 501415R1

Models LG8121*M, LG8153*B, LG8153*M, LG8163*M and LG8459*2

No. 500746R1

Models CG8409*2, LG8409*2, LG8519*2 and LG8569*2

No. 500743R3

Model LG8609*2

No. 500740R2

Model LG9209*2

No. 500704R4

Models LE4317*2, LG7111*B, LE7111*M and LE8317*2

No. 501887R2

Models LE4207*2, LE8207*2, LE8207*3, LE8107*2, and LE7101*B

No. 502266R1

Model CE4317*2 and CE8317*2

No. 502138R1

Models CE8407*2 and CE8517*2

No. 500799R2

Model CE9207*2

No. 503147

Models LE4217*2 and LE8217*2

No. 503149

Model LG4219*2 and LG8219*2