

GE Consumer & Industrial

# Technical Service Guide

August 2008

## Profile Dryer

DPVH880EJ  
DPVH880GJ

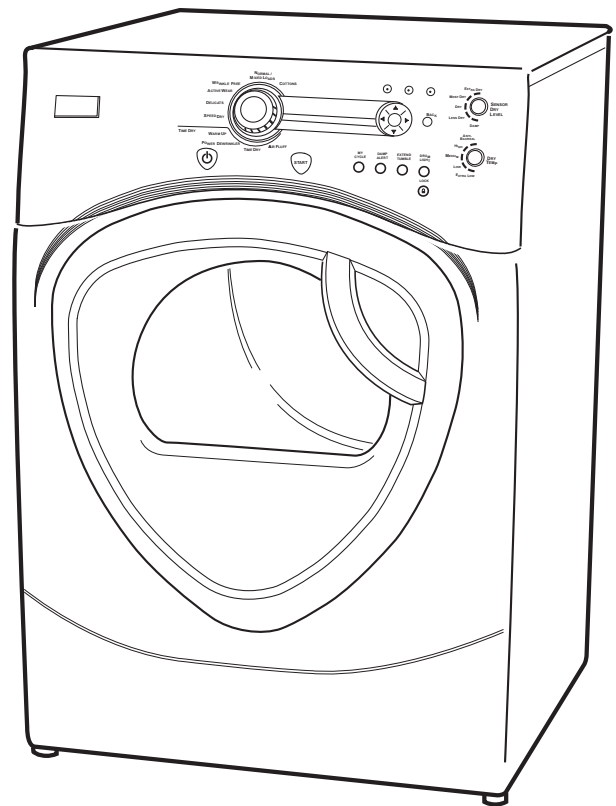

31-9167



GE Appliances  
General Electric Company  
Louisville, Kentucky 40225



## IMPORTANT SAFETY NOTICE

The information in this service guide is intended for use by individuals possessing adequate backgrounds of electrical, electronic, and mechanical experience. Any attempt to repair a major appliance may result in personal injury and property damage. The manufacturer or seller cannot be responsible for the interpretation of this information, nor can it assume any liability in connection with its use.

### WARNING

If the information in this manual is not followed exactly, fire or explosion may result causing property damage, personal injury or death. If you smell gas:

- Do not try to light any appliance.
- Do not touch any electrical switch; do not use any phone in the building.
- Immediately call the gas supplier from a neighbor's phone. Follow the gas supplier's instructions.
- If you cannot reach the gas supplier, call the fire department.

### WARNING

To avoid personal injury, disconnect power before servicing this product. If electrical power is required for diagnosis or test purposes, disconnect the power immediately after performing the necessary checks.

## RECONNECT ALL GROUNDING DEVICES

If grounding wires, screws, straps, clips, nuts, or washers used to complete a path to ground are removed for service, they must be returned to their original position and properly fastened.

*GE Consumer & Industrial*  
*Technical Service Guide*  
*Copyright © 2008*

All rights reserved. This service guide may not be reproduced in whole or in part in any form without written permission from the General Electric Company.

# Table of Contents

Air Duct Assembly .....	34
Airflow .....	27
Belt Switch.....	39
Blower Motor .....	40
Blower Wheel.....	42
Burner Assembly and LP Conversion .....	46
Component Locator Views.....	28
Control Board Assembly .....	54
Control Features.....	6
Control Panel.....	32
Cycle Options.....	10
Display Board .....	55
Door Switch .....	35
Drive Belt.....	36
Drum.....	37
Drum Motor .....	39
Drum Shaft and Bearing.....	38
Drum Slide Assembly.....	34
Dryer Components.....	32
Dryer Features .....	12
Dual Idler Assembly.....	38
Error Codes .....	60
Flame Detector .....	48
Front Panel.....	33
Fuses.....	36
Gas Valve.....	47
Gas Valve Coils.....	46
Heater Assembly.....	43
High Limit Thermostat.....	52
Ignitor .....	48
Ignitor Circuit Operation .....	49
Inlet Control Thermistor.....	51
Inlet Safety Thermostat.....	51
Introduction.....	5
Moisture Sensor .....	35
Nomenclature .....	4
Operation Overview.....	26
Outlet Control Backup Thermostat.....	53
Outlet Control Thermistor .....	52
Pedestal Installation (Washer and Dryer).....	20
Power Board.....	54
Power Board Connector Locator View.....	30
Rack Dry Calrod® Element .....	50
Rack Dry Thermostat.....	53
Reversing the Door Swing .....	14
Sales Demo Mode.....	11
Schematics and Wiring Diagrams .....	63
Service Test Mode.....	56
Stacking Instructions .....	23
Top Panel.....	33
Triac.....	43
Troubleshooting .....	56
Warranty .....	68

# Nomenclature

## Model Number

**D P V H 8 8 0 E J 0 W W**

### Brand

D = General Electric

### Feature Packages

P = Pedestal

### Capacity/Configuration

V = Very Big

### Backsplash Control/Platform

H = Horizontal

### Control Features

### Color

WW = White

MV = Vermillion (Red)

MG = Champagne

### Engineering Revision Alpha or Numeric

### Model Year

J = 2008

### Fuel/Voltage

E = 240V 60 Hz.

G = Gas 120V 60Hz.



The nomenclature tag is located on the front panel inside the door.

**Note:** The technical sheet is located inside the control panel.

## Serial Number

The first two characters of the serial number identify the month and year of manufacture.

Example: **AR123456S** = January, 2008

A - JAN	2008 - R
D - FEB	2007 - M
F - MAR	2006 - L
G - APR	2005 - H
H - MAY	2004 - G
L - JUN	2003 - F
M - JUL	2002 - D
R - AUG	2001 - A
S - SEP	2000 - Z
T - OCT	1999 - V
V - NOV	1998 - T
Z - DEC	1997 - S

The letter designating the year repeats every 12 years.

Example:

T - 1974

T - 1986

T - 1998

# Introduction

The new GE dryer has the following features:

- Large 7.5-cubic foot dryer drum - Reverses direction during cycle.
- Integrated Drying Rack for drying delicate items such as washable sweaters.
- Drum Lamp
- My Cycle selection saves a favorite cycle for future use.
- Built-in service test mode. Specific dryer components can be operated. Error codes are recorded and accessible on the control panel display.
- Dual Thermistors - Thermistors are more sensitive to temperature changes and can relay the information faster than thermostats. The dryer utilizes dual thermistors to monitor incoming air temperature as well as air temperature leaving the drum. The sensors work together with the variable heater and the blower to provide consistent, even heat.
- Moisture Sensor - The moisture sensor allows the control to monitor the fabric for moisture content and end the cycle at the desired moisture level.
- Flush Door Handle
- Reversible Door (Kit included.)
- UV Stabilizers - The control panel, control panel cover, and door outer panel have UV stabilizers to prevent yellowing when exposed to sunlight.
- The GE dryer can be installed on top of the GE Front Load Washer. (Stacking kit supplied with washer.)
- Pedestal available at additional cost. White (model number DPVH515EJ0WW), Red (model number DPVH515EJ0RR), and Gold (model number DPVH515EJ0GG)



**Note:** The electric dryer DPVH880EJ is not recommended for 208V installation.

# Control Features

**⚠ WARNING!** To reduce the risk of fire, electric shock, or injury to persons, read the IMPORTANT SAFETY INSTRUCTIONS before operating this appliance.

Throughout this manual, features and appearance may vary from your model.

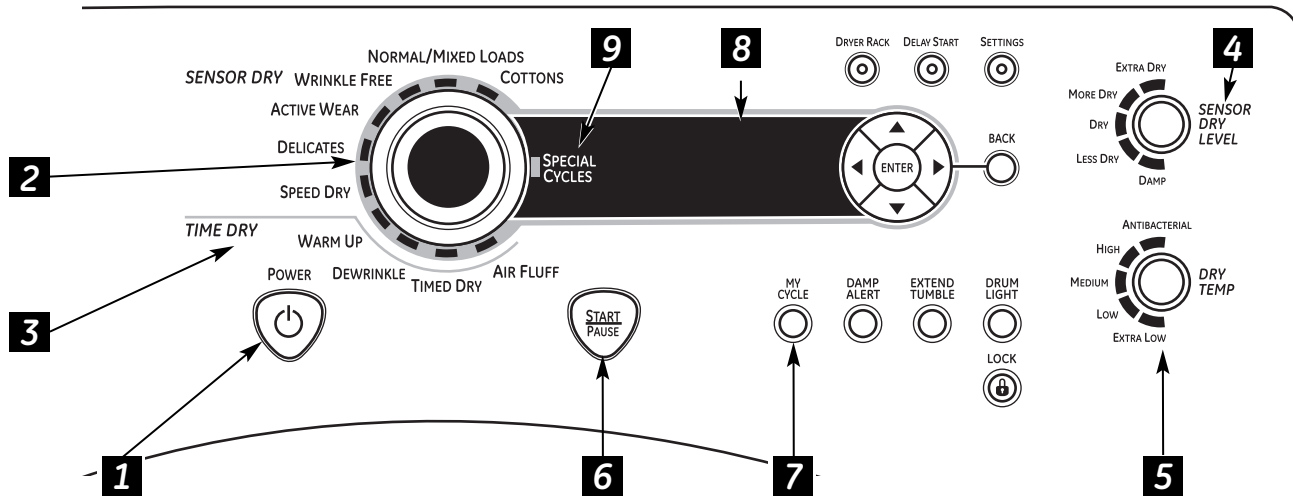

- 1 Power**  
Press to “wake up” the display. If the display is active, press to turn the dryer off.

**NOTE:** Pressing **POWER** does not disconnect the appliance from the power supply.

- 2 Dry Cycles**  
The dry cycle controls the cycle time for the drying process. The chart below will help you match the dry setting with the loads.

**Sensor Cycles**

<b>COTTONS</b>	For cottons and most linens.
<b>NORMAL/ MIXED LOAD</b>	For loads consisting of cottons and poly-blends.
<b>WRINKLE FREE</b>	For wrinkle-free/easy care and permanent press items.
<b>ACTIVE WEAR</b>	Clothing worn for active sports exercise and some casual wear. Fabrics include new technology finishes and stretch fibers such as Spandex.
<b>DELICATES</b>	For lingerie and special-care fabrics.
<b>SPEED DRY</b>	For small loads that are needed in a hurry, such as sports or school uniforms. Can also be used if the previous cycle left some items damp, such as collars or waistbands.

**Timed Dry Cycles**

<b>DEWRINKLE</b>	For removing wrinkles from items that are dry or slightly damp. This cycle is not recommended for delicate fabrics.
<b>WARM UP</b>	Provides 10 minutes of warming time to warm up clothes.
<b>AIR FLUFF</b>	Use this feature to tumble items without heat.

**My Cycle (on some models)**

<b>MY CYCLE</b>	Press to use, create or modify custom dry cycles.
-----------------	---

- 3 Timed Dry**  
Use to set your own dry time. **TIMED DRY** is also recommended for small loads.

**To use TIMED DRY:**

1. Turn dry cycle dial to **TIMED DRY**.
2. Select the drying time by pressing the + and – buttons. You can increase the time in 10-minute increments up to 2½ hours.
3. Select the **DRY TEMP**.
4. Close the door.
5. Press **START/PAUSE**.

- 4 Sensor Dry Level**  
The sensor continuously monitors the amount of moisture in the load. When the moisture in your clothes reaches your selected dry level, the dryer will stop.

<b>EXTRA DRY</b>	Use for heavy-duty fabrics or items that should be very dry, such as towels.
<b>MORE DRY</b>	Use for heavy or mixed type of fabrics.
<b>DRY</b>	Use for normal dryness level suitable for most loads. This is the preferred cycle for energy saving.
<b>LESS DRY</b>	Use for lighter fabric (ideal for ironing).
<b>DAMP</b>	For leaving items partially damp.

## 5 Dry Temp

You can change the temperature of your dry cycle.

**ANTI-BACTERIAL** This option may only be used with **COTTONS** or **MIXED LOAD** cycles. This option reduces certain types of bacteria by 99.9%, including: *Staphylococcus aureus*, *Pseudomonas aeruginosa* and *Klebsiella pneumoniae*\*. The anti-bacterial process occurs when high heat is used during a portion of this drying cycle.

**NOTE: Do not use this cycle on delicate fabrics.**

\* The Anti-Bacterial Cycle is Certified by NSF International (formerly National Sanitation Foundation) to NSF Protocol P154 Sanitization Performance of Residential Clothes Dryers.



NSF Protocol P154  
Sanitization Performance of  
Residential Clothes Dryers

<b>HIGH</b>	For regular to heavy cottons.
<b>MEDIUM</b>	For synthetics, blends and items labeled permanent press.
<b>LOW</b>	For delicates, synthetics and items labeled <i>Tumble Dry Low</i> .
<b>EXTRA LOW</b>	For lingerie and special-care fabrics.

## 6 START/PAUSE

Press to start a dry cycle. If the dryer is running, press it once and it will pause the dryer. Press it again to restart the dry cycle.

## 7

**MY CYCLE** *My Cycle* (on some models)

Set up your favorite combination of settings and save them here for one touch recall. These custom settings can be set while a cycle is in progress.

**To store a MY CYCLE combination of settings:**

1. Select your drying cycle.
2. Change **DRY TEMP** and **SENSOR DRY LEVEL** settings to fit your needs.
3. Select any drying **OPTIONS** you want.
4. Press and hold the **MY CYCLE** button for three seconds to store your selection. A beep will sound and the button will light up.

**To recall your stored MY CYCLE combination:**

Press the **MY CYCLE** button before drying a load. The light around the button will light up when **MY CYCLE** is selected.

**To change your stored MY CYCLE combination:**

Follow steps 1–4 in **"To store a MY CYCLE combination of settings"**.

## 8 Display

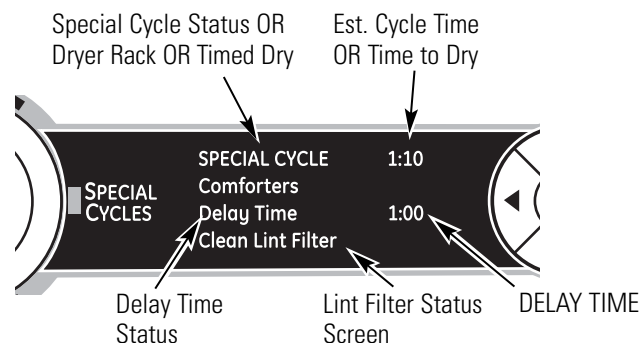

### **"CLEAN LINT FILTER" (message)**

This message stays on for 15 minutes after the cycle finishes. **This message is only a reminder.**



## 9 Specialty Cycles

1. Turn the **CYCLE** knob to **SPECIAL CYCLES**. A list of cycle options will appear in the display.
2. Using the cursor buttons, select a **CATEGORY**.
3. Using the cursor buttons, select a **CYCLE**.  
Press the **BACK** button to take you back to the **CATEGORIES**.
4. Press **ENTER** to select.
5. Press the **START/PAUSE** button.

**SPECIALTY CYCLES** include:

### **Garments**

- Jeans
- Khakis
- Coats
- Hosiery/Bras (use mesh bag)

### **Bed and Bath**

- Towels
- Sheets
- Blankets (Cotton)
- Down Pillows/Comforters

### **Other Specialty**

- Throw Rugs
- Pet Bedding
- Performance Garments
- Fleece
- Dryel
- Fragile Cotton
- Dryer Rack

---

## Washer Communicated Cycles

To turn on communication, press the **SETTINGS** button on the washer control panel. When “**DRYER LINK**” appears in the display, press **ENTER**. Using the arrow keys, select **ON**; then press **ENTER**.

When the washer cycle is completed, the washer will communicate with the dryer when any button on the control panel is touched or the door is opened.

The washer will display, “**TRANSFERRING CYCLE INFORMATION TO THE DRYER**” and the dryer will display, “**RECEIVING CYCLE INFORMATION TO THE DRYER**”.

The dryer will only communicate with the washer if the dryer is not running a cycle.

If the washer starts a new cycle before the dryer has a chance to communicate with it, the information will be lost.

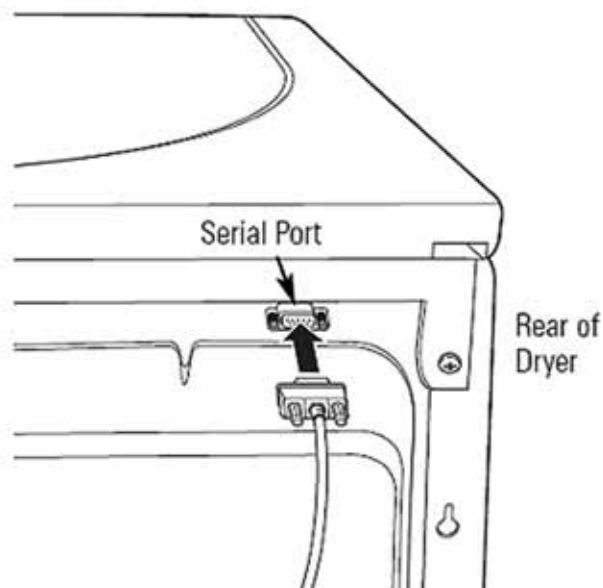

## Cycle Options

Note: Not all features are available on all dryer models.

### EXTEND TUMBLE



#### Extend Tumble

Minimizes wrinkles by adding approximately 60 minutes of no-heat tumbling after clothes are dry. The beeper will sound every 2 minutes to remind you to remove the clothes. The **ESTIMATED TIME REMAINING** display will show **00**.

The light around the button will light up when **EXTEND TUMBLE** is on.

### DAMP ALERT



#### Damp Alert

This option causes the dryer to beep when clothes have dried to a damp level. Remove items that you wish to hang dry. The **DAMP ALERT** will only beep when this option is selected.

Removing clothes and hanging them when they are damp can reduce the need to iron some items.

The light around the button will light up when **DAMP ALERT** is on.

### DRUM LIGHT



#### Drum Light

Press this button to turn on the light in the dryer.

Press the button again to turn the light off.

This only controls the light when the door is shut. When the door is opened, the light comes on automatically.

The light around the button will light up when **DRUM LIGHT** is on.

### DELAY START



#### Delay Start

Use to delay the start of your dryer.

1. Choose your dry cycle and any options.
2. Press **DELAY START**. You can change the delay time in 1/2 hour increments, using the + or - arrow pads.
3. Press the **START/PAUSE** button to start the countdown.

The countdown time will be shown in the **ESTIMATED TIME REMAINING** display.

#### NOTES:

- If the door is opened while the dryer is in **DELAY**, the countdown time will not restart unless the door is closed and **START/PAUSE** button has been pressed again.
- You can delay the start of a dry cycle up to 24 hours.

The light around the button will light up when **DELAY START** is on.

### LOCK



#### Lock

You can lock the controls to prevent any selections from being made. Or you can lock the controls after you have started a cycle.

*Children cannot accidentally start the dryer by touching pads with this option selected.*

To lock the dryer, press the **LOCK** button. To unlock the dryer, press and hold the **LOCK** button for 3 seconds.

The light around the **LOCK** button will light up when the controls are locked.

Even though the controls are locked, the **POWER** button is still active in case you have to turn the unit off.

Press to lock control.  
Hold 3 seconds to unlock.

## SETTINGS



### Settings

Under the **SETTINGS** option, you can adjust the volume or the brightness of the display.

#### VOLUME

- End of Cycle (signal) volume can be set from **HIGH, MED, LOW** or **OFF**.
- Control Sounds volume can be set from **HIGH, MED, LOW** or **OFF**.

**DISPLAY BRIGHTNESS** can be set from **HIGH, MED** or **LOW**.

After you have made your selection, press enter.

## Sales Demo Mode

This mode allows the user to view a dryer cycle. When in the sales mode, it will not operate through normal cycles, but will simulate those cycles electronically on the display.

TO ENTER DEMO MODE:

1. Unplug dryer. Reconnect power.
2. Within 30 seconds of plugging unit in, open door and press **START/PAUSE** 4 times within 3 seconds.
3. **DEMO MODE ENTRY** will appear on display.



Once in Demo mode, if there are no key presses, the display will begin to scroll "DEMO MODE - TRY ME".



TO EXIT DEMO MODE:

1. Unplug dryer. Reconnect power.
2. Within 30 seconds of plugging unit in, open door and press **START/PAUSE** 4 times within 3 seconds.
3. **DEMO MODE EXIT** will appear on display.



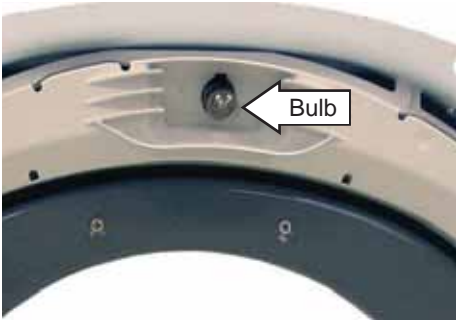

### Drum Lamp

Before replacing the light bulb, be sure to unplug the dryer power cord or disconnect the dryer at the household distribution panel by removing the fuse or switching off the circuit breaker. The bulb is a 120 VAC, 10-watt, threaded base bulb. Reach above dryer opening from inside the drum. Remove the bulb and replace with the same size bulb (Part # WE4M305).

### Built-in Rack Dry System™ with Tumble Care Baffles™

A handy drying rack may be used for drying items, such as tennis shoes. Place items flat on the drying rack and block such items as wool sweaters and delicate fabrics. Dry with low heat.

#### To install the Built-in Rack Dry System™ with Tumble Care Baffles™

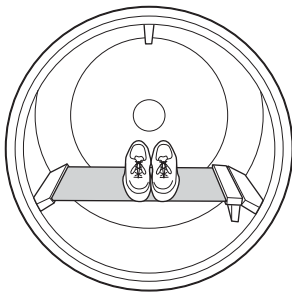

1. Make sure the drum of the dryer is oriented so the rack drying system is on the left side of the dryer.
2. Pull the drying rack screen out from the left side and engage the handle "post" in the opposite baffle slots.
3. Place the garment on the rack and close the door.
4. Press the **DRYER RACK** button.
5. Select desired TIME.
6. Press the **START/PAUSE** button.

#### Note:

- On electric models, if the drum light is activated by selecting **DRUM LIGHT** on the control panel during the rack dry cycle, heater operation will stop.
- Do not use this drying rack when there are other clothes in the dryer.
- Make sure to detach the drying rack at the end of the cycle.

### Drying Rack (*Optional Accessory*)

A handy drying rack may be used for drying delicate items, such as washable sweaters. Place items flat on the drying rack and block such items as wool sweaters and delicate fabrics. Dry with low heat.

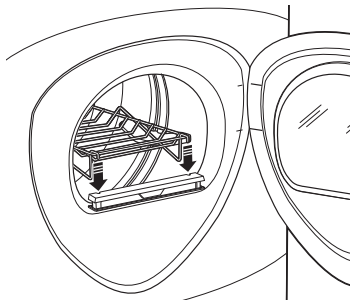

To install the drying rack, pull up the lint filter slightly. Insert the drying rack into the slots, then push the filter back down.

#### Note

- The drying rack must be used with the TIMED DRY or RACKDRY (on some models) cycle.
- Do not use this drying rack when there are other clothes in the dryer.

---

### To Use the Built-In Hook for Hanging Garments

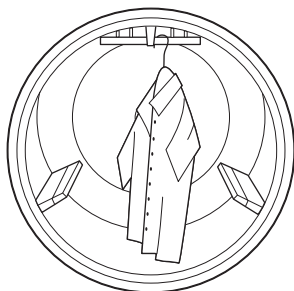

1. Make sure the drum of the dryer is oriented so the rack drying system is on the top center of the dryer.
2. Using your finger, pull the hook out of the baffle.
3. Hang the garment on a hanger, hang the hanger on the hook, and close the door.
4. Press the **DRYING RACK** button.
5. Select the desired **TIME**.
6. Press the **START/PAUSE** button.

# Reversing the Door Swing

## Important Notes:

- Read the instructions all the way through before starting.
- Handle parts carefully to avoid scratching paint.
- Provide a non-scratching work surface for the doors.
- Set screws down by their related parts to avoid using them in the wrong places.
- All screws must be hand-tightened.
- Normal completion time to reverse the door swing is 30–60 minutes.

**Important:** Once you begin, do not move the cabinet until door-swing reversal is completed.

These instructions are for changing the hinges from the right side to the left side—if you ever want to switch them back to the right side, follow these same instructions and reverse all references to the left and right.

## Tools Needed

Phillips-head Screwdriver



Putty Knife or Thin-Blade Screwdriver



## Kit Contents

Chrome Door Cap



Chrome Door Hinge Cap



Inner Door Cap



Door Parts

Hinge Cap



Outer Handle

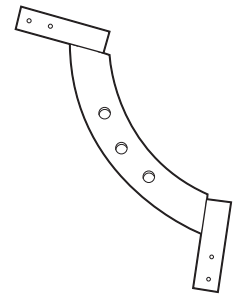

Chrome Door Cover

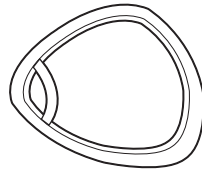

Inner Door Cap

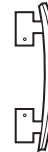

2 #8 x 0.75" Small Tapping Screws



4 #8 x 0.50" Machine Screws



Hinge Assembly

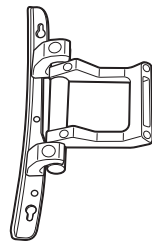

7 #10 x 1.125" Large Tapping Screws

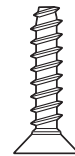

Chrome Door Cap



Inner Handle

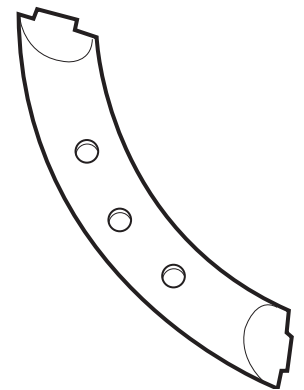

9 #8 x 0.625" Small Tapping Screws



2 Handle Caps



2 #10 x 0.750" Large Tapping Screws



**To reverse the door swing:**

1. Unplug the dryer from its electrical outlet.

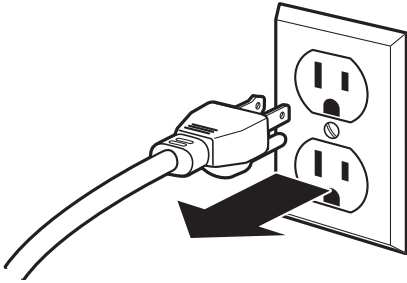

2. Remove the side hinge cap by opening the dryer door and removing the screw from behind the hinge. Then, using your hand, pop the hinge cap off the dryer.

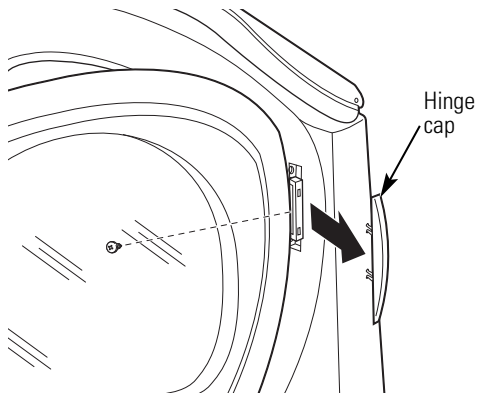

3. Hold the door and remove the 2 hinge (#10 x 0.75-in.) tapping screws. Pull the door away from the dryer front panel.

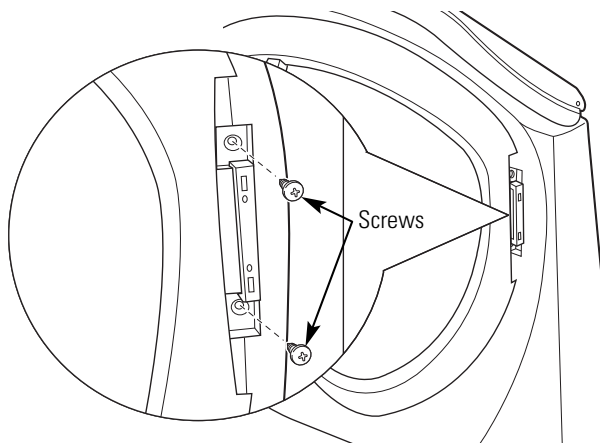

4. Lay the door down on a soft, protected, flat surface so the inner part faces upward (door resting on the handle side).
5. Remove the 7 (#10 x 1.125-in.) tapping screws located around the perimeter of the door.

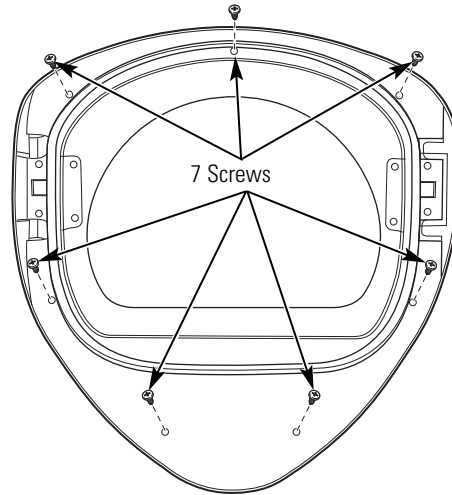

6. Turn the door assembly over and separate the chrome cover from the inner door. Put the inner door aside on a soft, protected, flat surface.



7. Lay the chrome cover down on a soft, protected, flat surface so the inner part faces upward (resting on the handle side).
8. Disassemble the door cap from the chrome cover on the handle side by removing 2 (#8 x 0.625-in.) tapping screws.

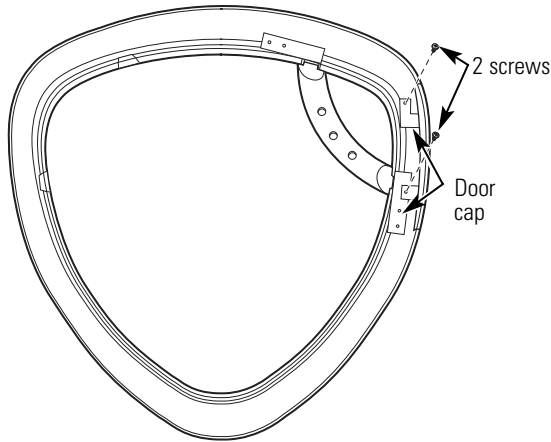

10. Pop the 2 handle caps out toward you and reassemble on the opposite side of the chrome cover, where you removed the outer handle.

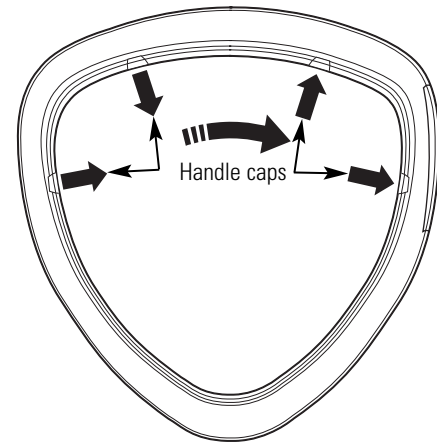

9. Disassemble the inner handle from the outer handle by removing 3 (#8 x 0.625-in.) tapping screws. Disassemble the outer handle from the chrome cover by removing 4 (#8 x 0.625-in.) tapping screws.

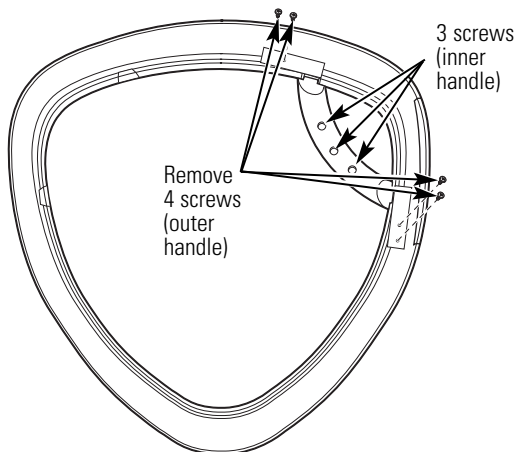

11. Assemble the outer handle onto the opposite side of the chrome cover, using 4 (#8 x 0.625-in.) tapping screws. Reassemble the inner handle to the outer handle, using 3 (#8 x 0.625-in.) tapping screws.

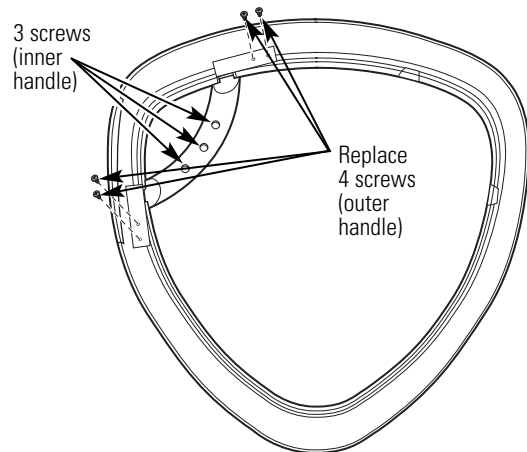

- Assemble the new right-side door cap (from reversibility kit), using 2 (#8 x 0.625-in.) tapping screws.

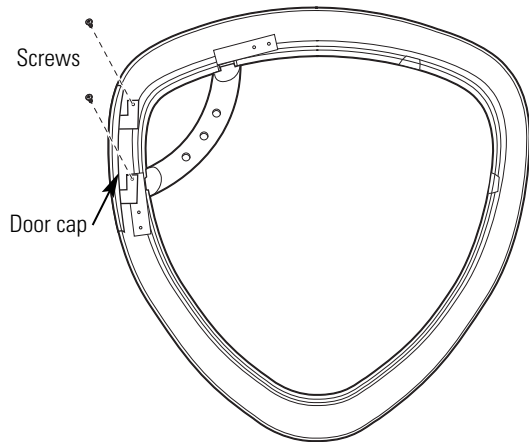

- Put the chrome cover aside on a soft, protected, flat surface.

- Lay the inner door down on a soft, protected, flat surface so the inner part faces up.

- Remove the 2 plug buttons on the opposite side of the hinge, using a putty knife or thin-blade screwdriver.

- Disassemble the inner door cap from the inner door by removing 2 (#8 x 0.75-in.) tapping screws.

- Disassemble the hinge from the inner door by removing 4 (#8-32 x 0.50-in.) machine screws.

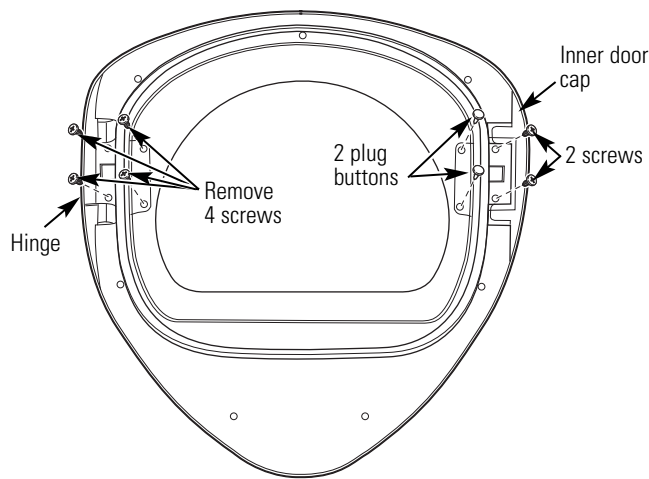

- Assemble the hinge to the opposite side of the inner door, using 4 (#8-32 x 0.50-in.) machine screws.

- Assemble the new inner door cap (from reversibility kit) on the opposite side of the hinge, using 2 (#8 x 0.75-in.) tapping screws.

- Install the 2 plug buttons on the opposite side of the hinge in the 2 remaining holes.

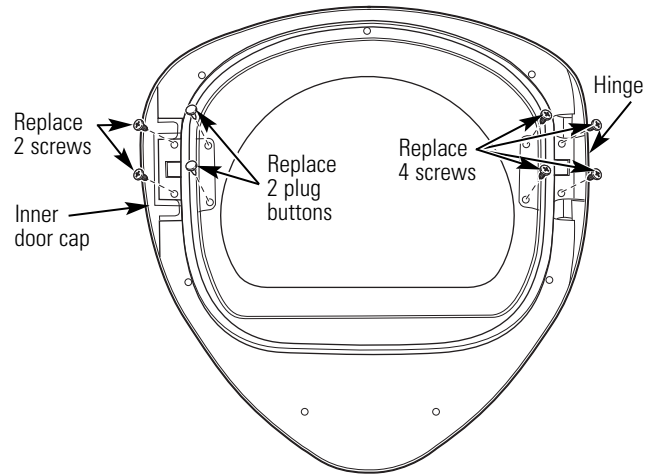

- Turn the inner door over and place on a soft, protected, flat surface so that the inner part is facing down.

22. Assemble the chrome cover to the inner door by placing them together. Flip the door assembly over and assemble, using 7 (#10 x 1.125-in.) tapping screws.

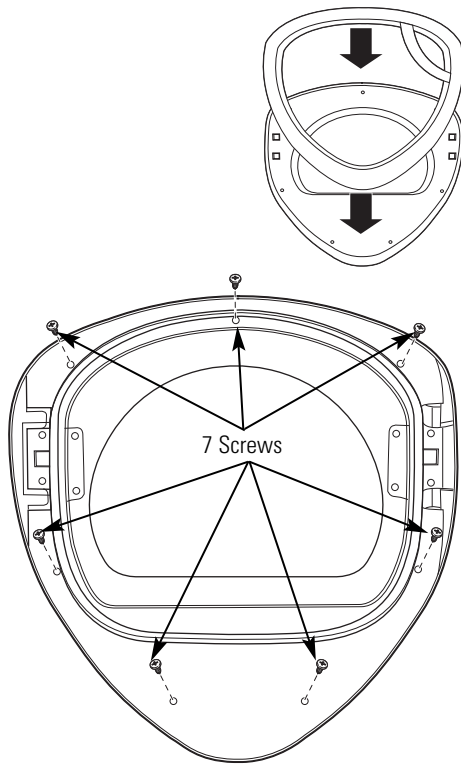

23. Remove the 2 plug buttons on the dryer front panel, using a putty knife or other flat tool, and reinstall on the opposite side. Switch the strike bracket and its cover by removing 2 (#8 x 0.625-in.) tapping screws for each and reinstalling on opposite sides.

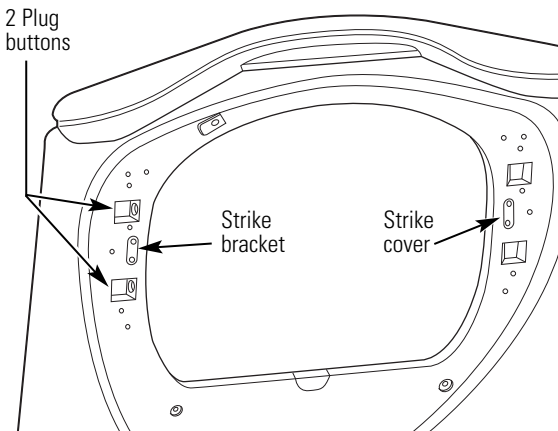

24. Place the door back on the dryer front panel, making sure the latch is engaged and the hinge is sitting in the two openings in the dryer front. Assemble the door to the front cabinet, using 2 (#10 x 0.75-in.) tapping screws.

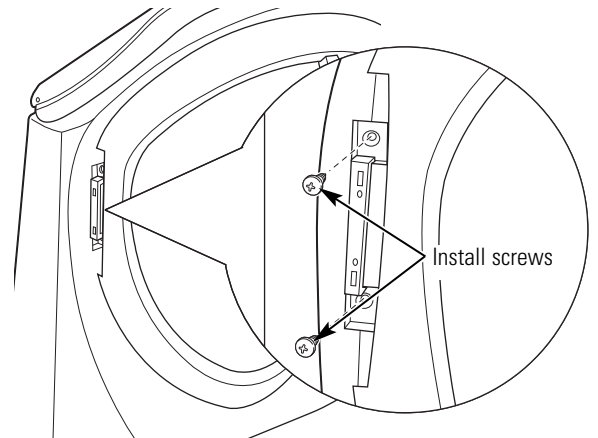

25. Install the new left-hand hinge cap (from the reversibility kit) onto the hinge, by opening the dryer door and screwing the hinge cap into place.

**Note:** Save the remaining caps and covers in case you want to reverse the hinge again.

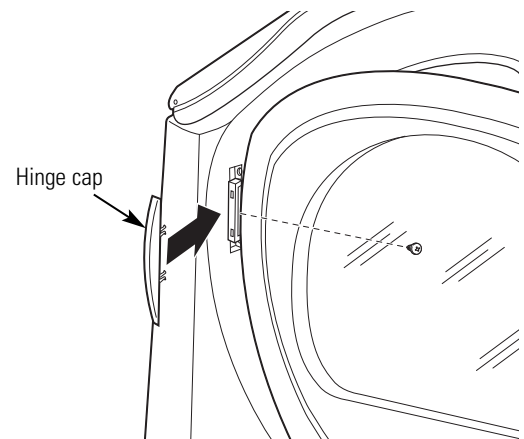

26. Plug the dryer into its electrical outlet.

# Pedestal Installation (Washer and Dryer)

Optional 12-inch-high storage drawer pedestals with dividers are available to provide convenience and extra storage space for detergent, dryer sheets, and other cleaning supplies. The pedestal installation kit includes 4 support pads, 4 mounting screws, and a drawer divider.



## WARNING!

Due to the size and weight of these products, and to reduce the risk of personal injury or damage to the product, two people are required for proper installation.

### Kit Contents

4 Support Pads



4 Mounting Screws



Drawer Divider

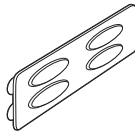

### Tools Needed

Phillips-head Screwdriver



9/16" Open End Wrench  
or Adjustable Wrench



8 mm Socket Wrench

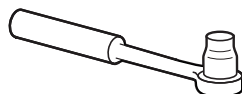

Spirit Level



### Installation Preparation

- Remove the packaging.
- The drawer divider is taped at the top of the shipping carton. Remove the divider and set aside for final installation.
- Flatten the product carton to use as a pad to lay the washer or dryer down on its side. Continue using the carton to protect the finished floor in front of the installation location.

### To install the pedestal:

1. Carefully lay the washer or dryer on its side to access the leveling legs on the bottom of the appliance.

**Caution:** Do not lay the washer or dryer on its back!

**Note:** Use an open-end wrench to remove the washer or dryer leveling legs.

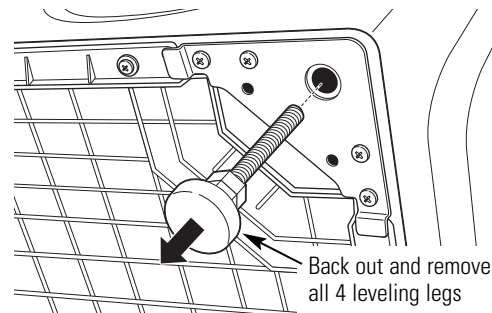

3. Pull the drawer out as far as it will go.
4. Remove screws from drawer slides. Slide drawer out of the base and set aside.

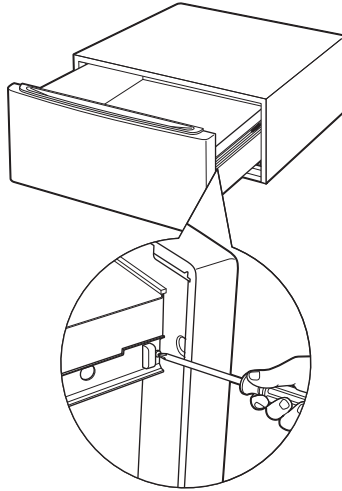

**Note:** The support pads should be installed on the dryer only. **DO NOT INSTALL THESE PADS ON THE WASHER PEDESTAL.**

5. Locate the 4 support pads from the parts package. Each pad has 2 protrusions that fit into the holes on top of the pedestal. Press the rubber pads into each set of corner holes on the top of the pedestal as shown.

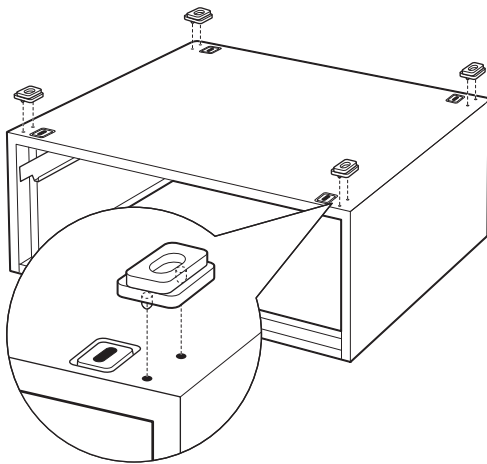

6. Place the pedestal against the bottom of the washer or dryer. Check to be sure the drawer front is at the front of the washer or dryer.
7. Align the holes in the pedestal with the holes in the bottom of the washer or dryer. Use a Phillips screwdriver to install the 4 bolts through the pedestal and into the washer or dryer—do not tighten.

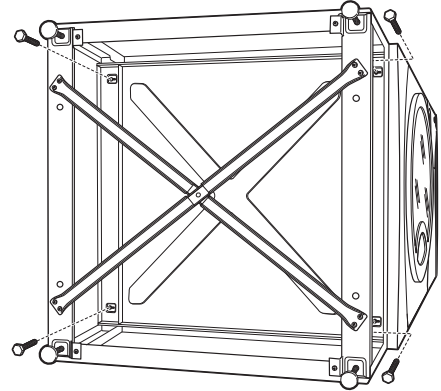

8. Slide the pedestal toward the washer or dryer, until it is aligned front to back. Use an 8-mm socket wrench to securely tighten the bolts.

9. Stand the washer or dryer upright. Move it close to its final location.
10. Make sure that the washer or dryer is level by placing a spirit level on top. Check side to side and front to back.
11. Use an open ended or adjustable wrench to adjust the legs in and out. Tighten the locknuts against the bottom of the pedestal.

**Note:** To minimize vibration, the locking nuts must be tight.

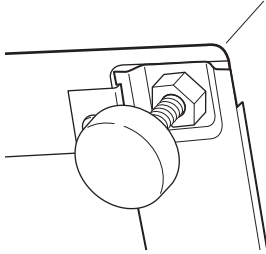

14. Reinstall the original screws into each drawer slide. Tighten both screws.
15. Open the drawer fully. Slide drawer divider into slots in the center of the drawer. The drawer should slide smoothly when you push it closed.
16. Remove the 4 shipping screws on the back side of the washer.

**Note:** Refer to the dryer Installation instructions (Pub# 49-90341) to complete the installation.

12. Check to be sure the slides are closed.
13. Slide the drawer into the opening. Align the drawer supports to the slides on each side.

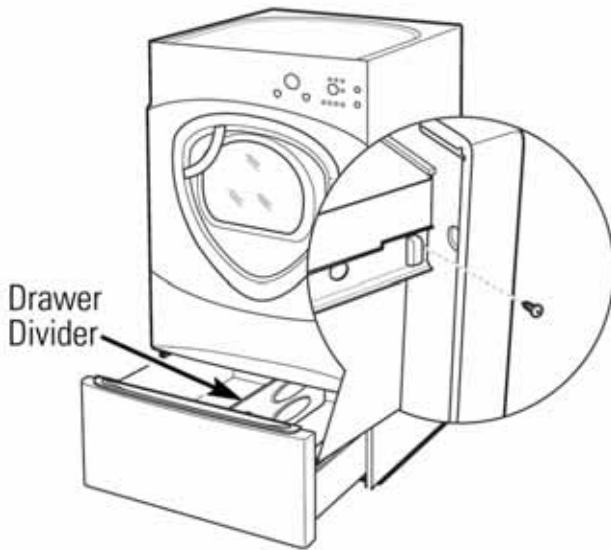

# Stacking Instructions

The GE dryer is designed to allow placement (stacking) on top of certain GE front load washers. Washer models that currently qualify are:

- WBVH6240
- WCVH6260
- WHDVH626

The parts and instructions necessary to convert the separate units to a stack unit are included with the washer installation parts.

## Note

- The stacking parts and instructions are NOT included with the GE dryers but can be ordered separately. (Part # WE25X10018)
- Reverse the dryer door swing (if desired) BEFORE stacking. The washer door swing is NOT reversible.

## WARNING!

- Make sure the dryer is unplugged.
- More than 2 people are recommended to safely lift the dryer into position.
- Avoid damage to the existing utility services.
- DO NOT place the washer on top of the dryer.
- Stacking of a gas dryer is NOT permitted in a mobile home or a manufactured home.

## Location Requirements

When installed in a location other than an alcove or closet, the minimal clearances to combustible surfaces and for air opening are: 0 inches on both sides, and 1 inch at the rear.

**Note:** If your dryer is approved for installation in an alcove or a closet, it will be stated on a label on the back.

When installed in an alcove or closet:

- Minimum clearance between dryer cabinet and adjacent walls or other surfaces is 0 inches either side, and 3 inches front and rear.

- Minimum vertical space from floor to overhead cabinets, ceiling, etc. is 43 inches without pedestal, 55 inches with pedestal, and 84 inches stacked. Closet doors must be louvered or otherwise ventilated and must contain a minimum of 120 square inches of open area, equally distributed.
- The dryer MUST be vented to the outdoors. (Refer to dryer installation instructions for details.)

## Kit Contents

Right Bracket

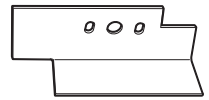

Left Bracket

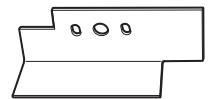

4 Rubber Pads



4 #12 x 1" Screws



4 #8 x 1/2" Screws



## Tools Needed

Phillips Screwdriver

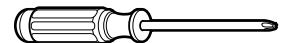

Open End Wrench



Pliers

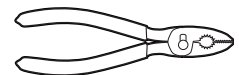

Gloves



Level



## To stack the dryer:

**Caution:** Do not lay dryer on its back. Use the packing material or a protective surface when laying dryer on its side.

1. Carefully lay the dryer on its side.

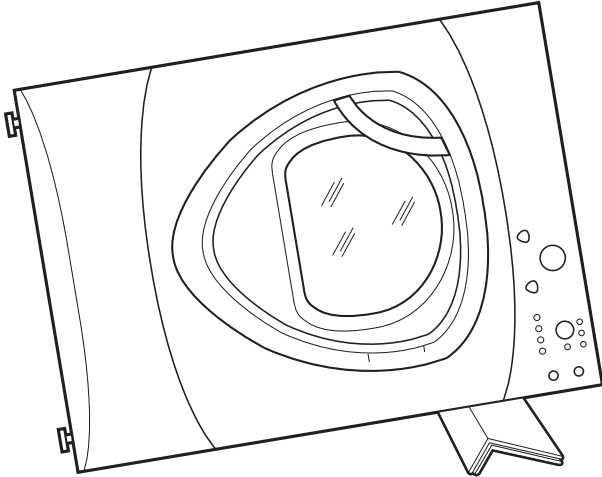

2. Use an open-end wrench or pliers to remove the 4 dryer leveling legs from the leg brackets.

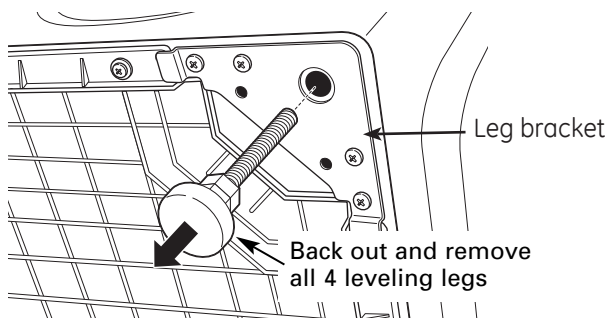

3. Remove the adhesive backing and firmly place the 4 rubber pads over the leg brackets.

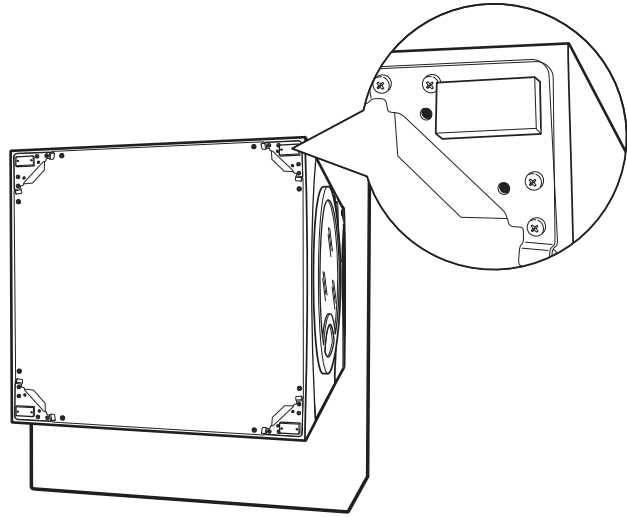

4. Align the holes in the left bracket with the holes in the bottom left corner of the dryer. Attach the bracket using 2 (#12 x 1-in.) Phillips-head screws.

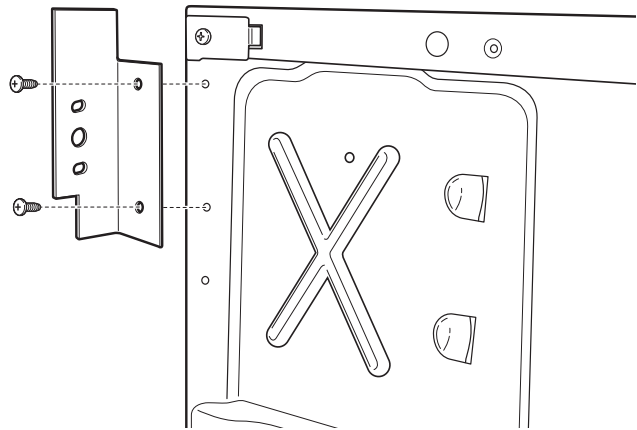

5. Align the holes in the right bracket with the holes in the bottom right corner of the dryer. Attach the bracket using 2 (#12 x 1-in.) Phillips-head screws.



6. Set the dryer upright using packing material or a protective surface that ensures the brackets do not damage the floor.
7. Place and level the washer in the approximate location. (Refer to washer installation instructions for details.)

**Caution:** Protect the washer control panel with cardboard or other protection to prevent damage caused by contact with the dryer brackets.

8. Lift the dryer high enough to clear the washer control panel and place the dryer on top of the washer.
9. Align the holes in the brackets with the holes in the back of the washer. Attach the brackets to the washer using 4 (#8 x 1/2-in.) Phillips-head screws.

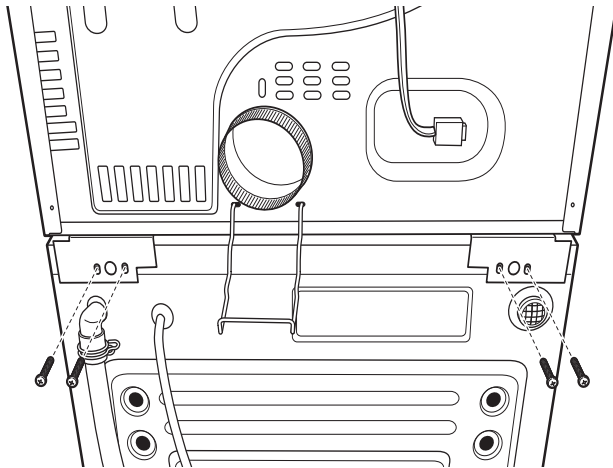

## **WARNING!**

Do not push on the dryer after it is stacked on the washer. Pushing on the dryer may result in pinched fingers.

**Caution:** Use felt pads or other sliding device to assist moving and to protect flooring.

**Note:** Ensure that the washer and the dryer are in compliance with their respective installation instructions.

10. Carefully slide or walk the stacked washer and dryer into place.

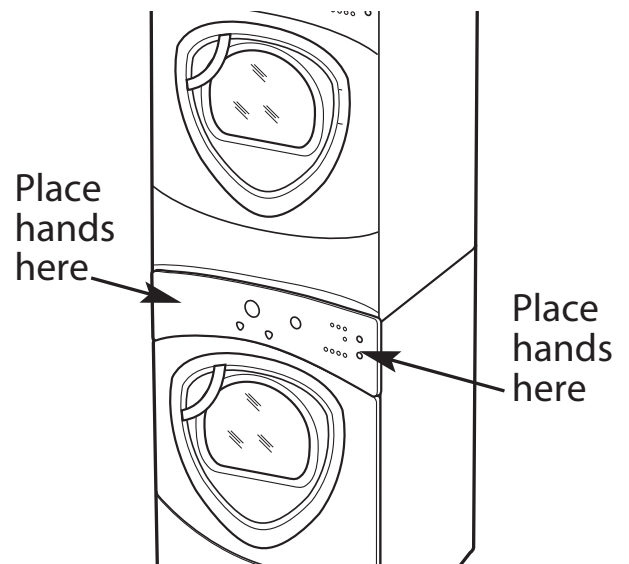

# Operation Overview

Air enters the dryer cabinet, passing through the heating coils (electric models) or the diffuser (gas models) and into the drum. The hot air heats the wet clothes, gradually removing their moisture in the form of water vapor. The moist air is vented through the dryer exhaust. Overall heater temperature is regulated by means of two temperature sensors, an inlet sensor, located near the heating coils or diffuser, and an outlet sensor, located at the blower. A safety thermostat, located on the heater pan or diffuser, and an outlet backup thermostat, located near the blower, cycle the heating coils (burner on gas models) if temperatures are excessive. A high limit thermostat, also located on the heater pan or diffuser, provides additional safety. If the thermostat reaches a temperature beyond its maximum temperature rating, power will be interrupted to the heating coils (burner on gas models) and the main control board, thereby terminating dryer operation. A rack dry thermostat, located at the blower, cycles the heating coils (burner on gas models) if temperatures are excessive when using the Rack Dry System™.

Dryer Air Flow System

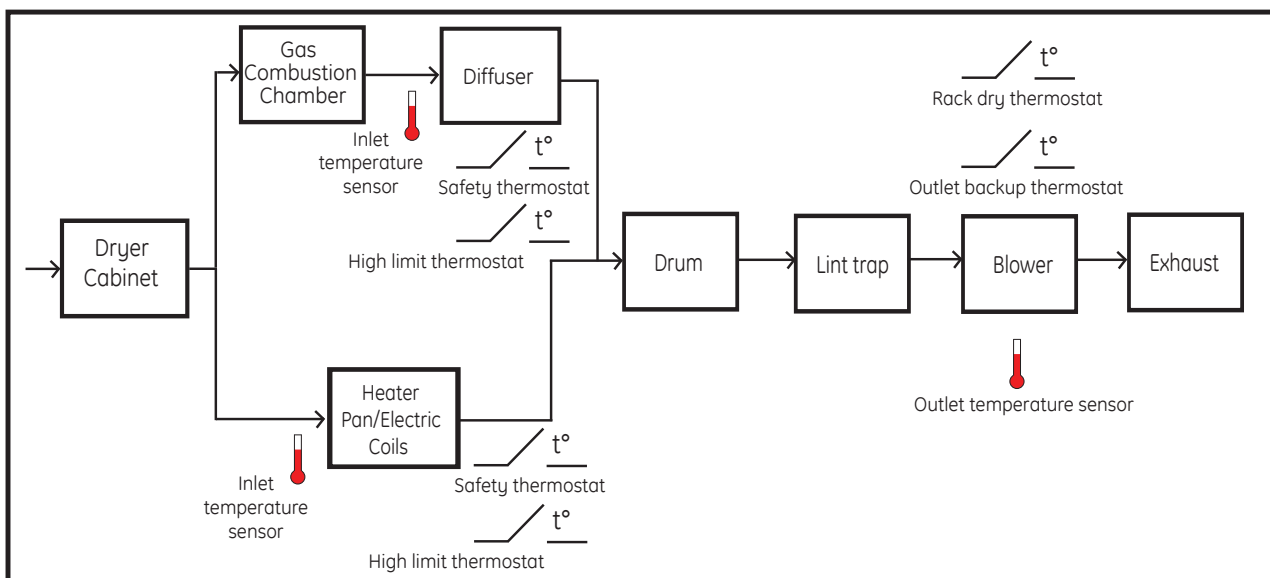

The typical dryer cycle progresses as follows:

1. A cycle is selected and the **START** button is pressed.
2. The motor(s) are activated. The drum motor rotates the drum at a speed of 47-51 RPM (revolutions per minute) for 1 minute clockwise and 9 minutes counterclockwise. The drum motor comes to a complete stop between direction changes. (Drum does not rotate in rack dry cycle.)
3. The heater coils (burner for gas models) are activated. The coils (burner) cycle on and off to achieve the desired temperature throughout the heating portion of the cycle.
4. If sensor drying is selected, the heater coils (burner for gas models) are activated. The coils (burner) cycle on and off until the load has achieved the desired dryness level.
5. If timed drying is selected, the heater coils (burner for gas models) are activated and cycle on and off for the selected time at the selected temperature.
6. The heater coils (burner for gas models) discontinue operation after the dryness level or elapsed time has been achieved.
7. The motor(s) continue operating until the clothes temperature drops below specified temperature (cool down).
9. The display turns off.

# Airflow

## Gas Dryer

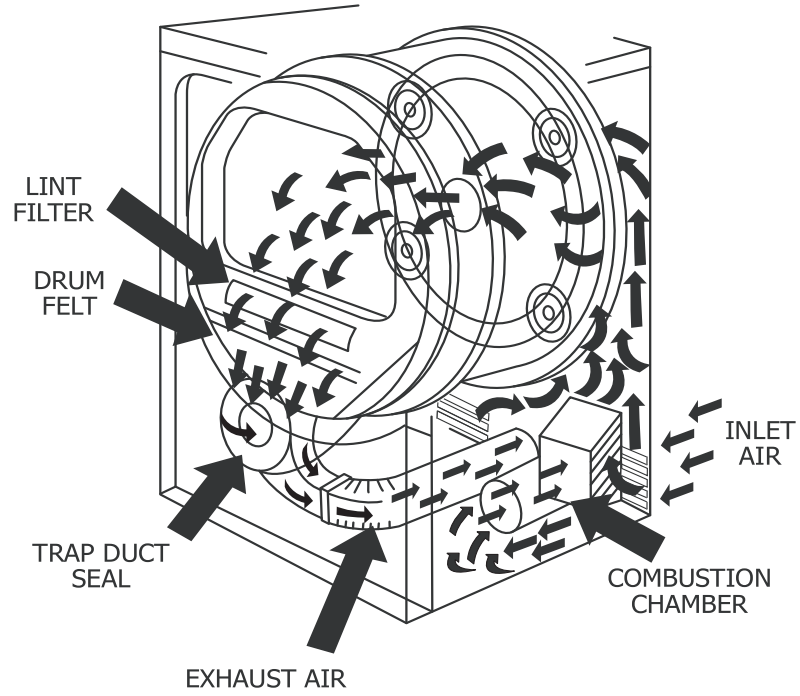

## Electric Dryer

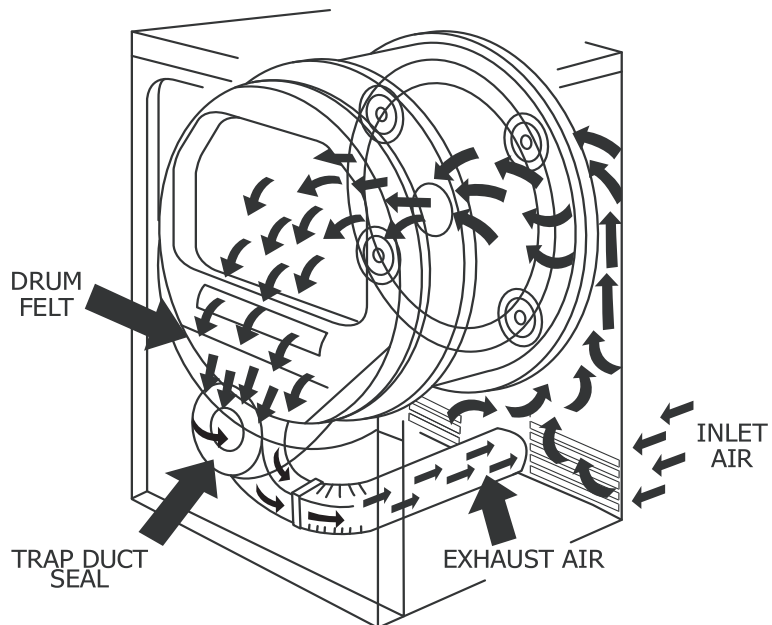

# Component Locator Views

## Electric Model

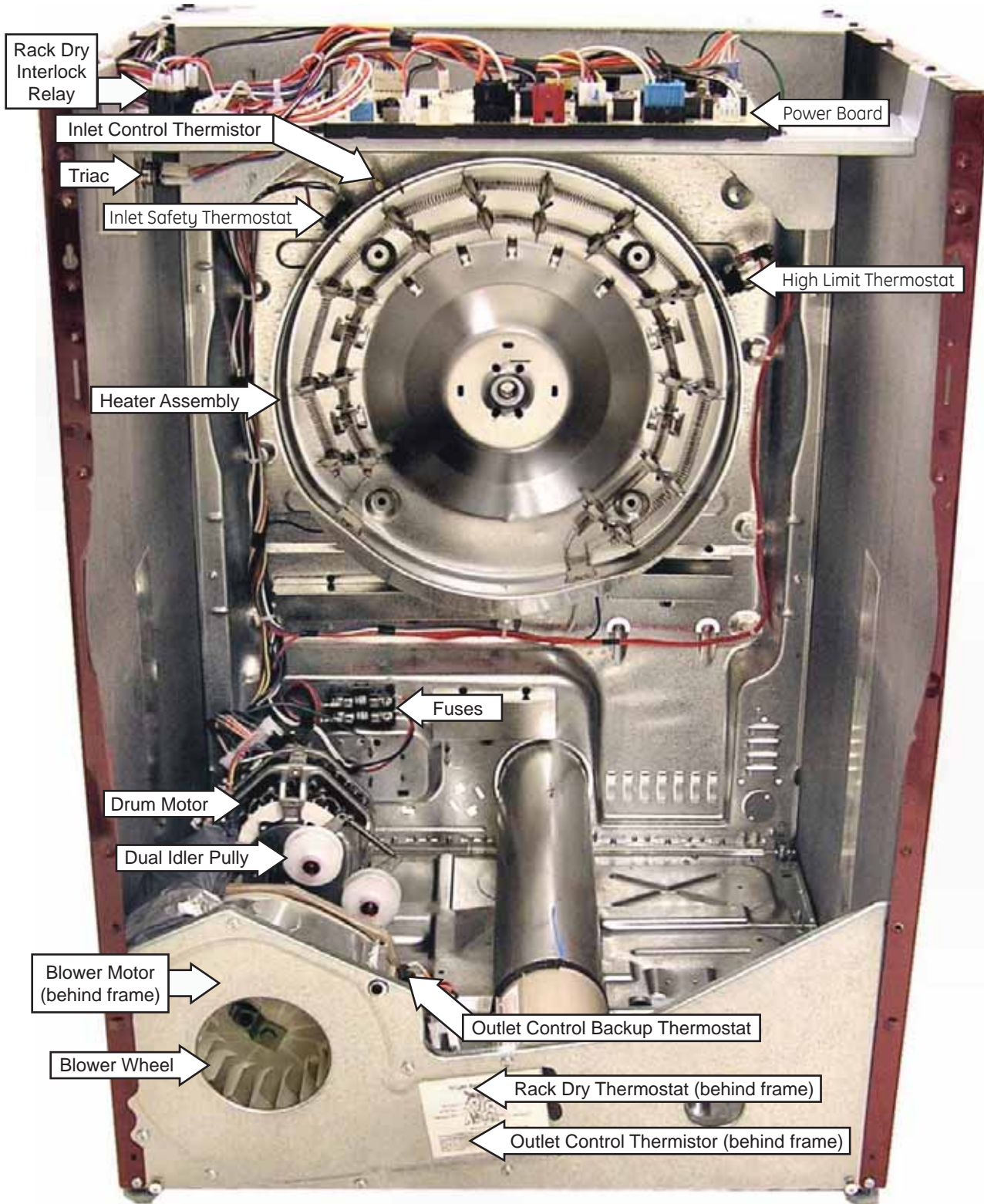

# Gas Model

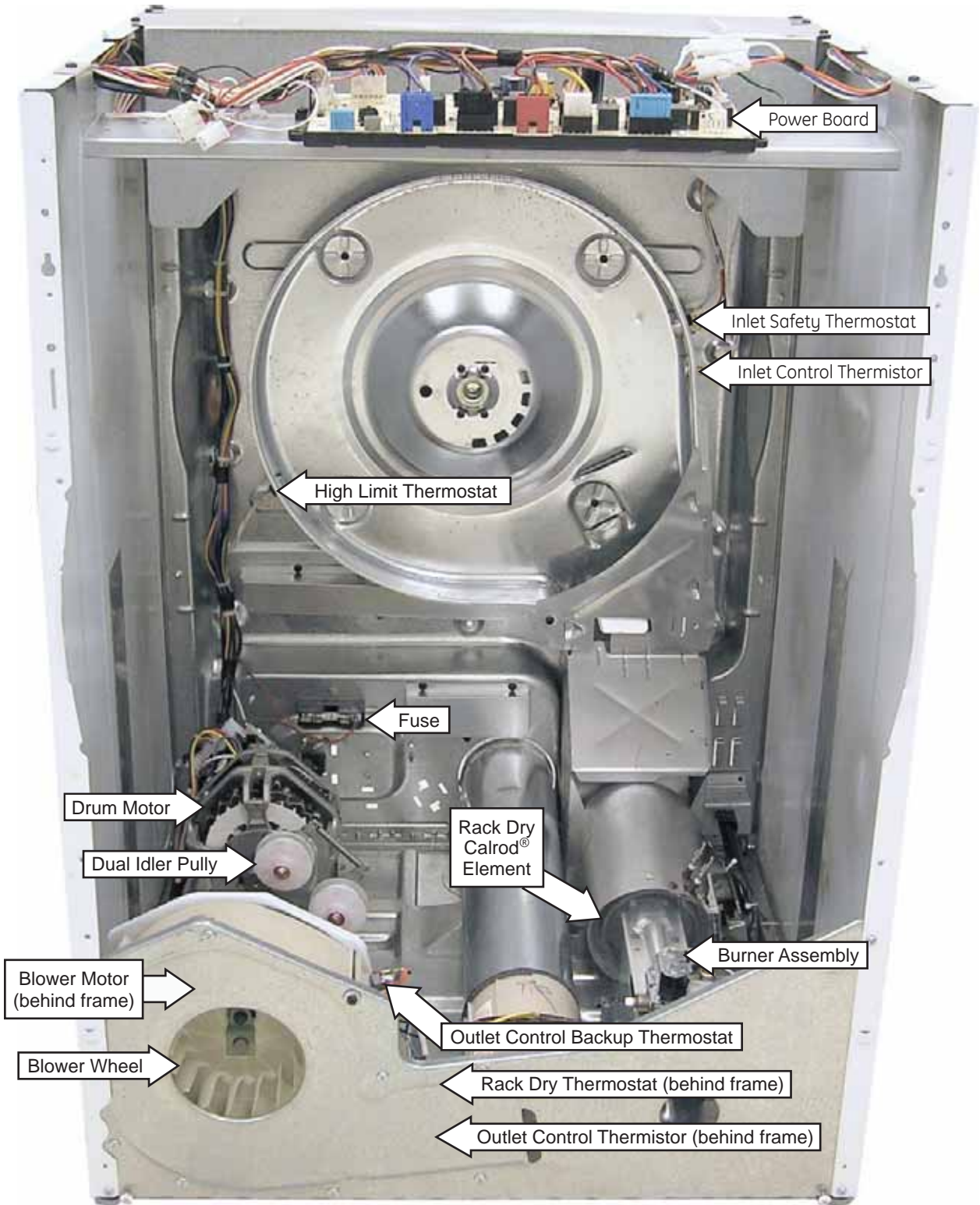

# Power Board Connector Locator View

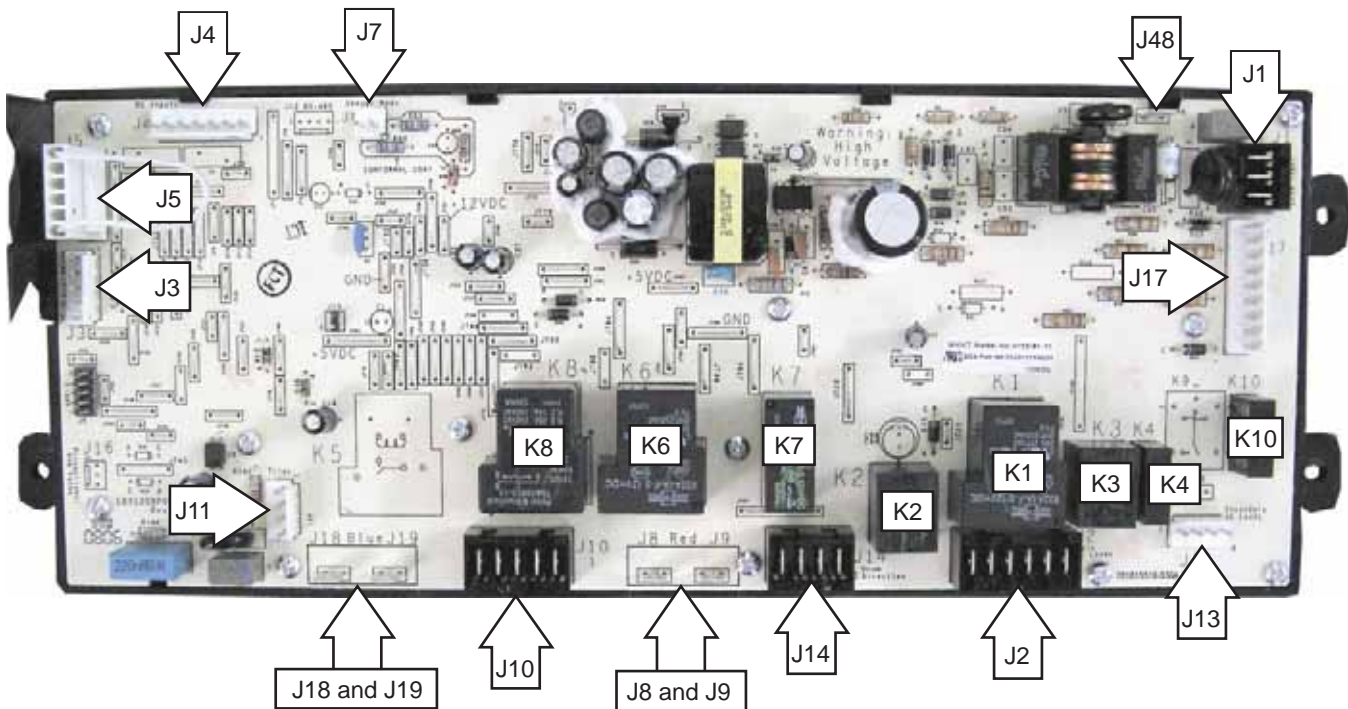

- J1 - L1 and Neutral Supply to Power Board
- J2 - Drum Motor
- J3 - Washer/Dryer Communication Cable
- J4 - 5 VDC, Hall Effect Input, Logic Ground, Outlet Control Thermistor, Inlet Control Thermistor
- J5 - Model Selector
- J7 - Sensor Rods
- J8 and J9 - Rack Dry Circuit Selection
- J10 - Rack Dry Mode Selection
- J11 - Triac
- J13 - Drum Lamp, Half Power (Gas)
- J14 - Drum Direction
- J17 - AC Inputs from Drum Motor and Power Board
- J18 and J19 - Tumble Hold-Up (Gas)
- J48 - Ground

- K1 - Drum Motor Relay
- K2 - Blower Motor Relay
- K3 - Gas Ignitor Shut-Off and 2nd Stage Relay
- K4 - Half-Power 1st Stage Relay (Gas)
- K5 - Rack Dry Interlock Relay (Electric)\*
- K6 - Rack Dry Selection Relay
- K7 - Drum Motor Reversing Relay
- K8 - Rack Dry Circuit Mode Relay
- K10 - Lamp Relay

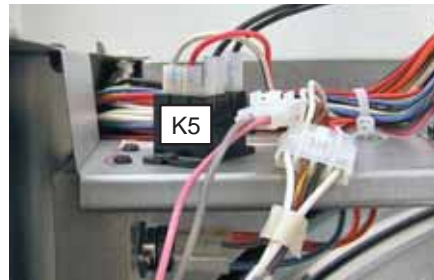

\*K5 relay is located on power board bracket.  
(See *Component Locator Views*.)

# Control Board Assembly (Electric and Gas Models)

Rear View

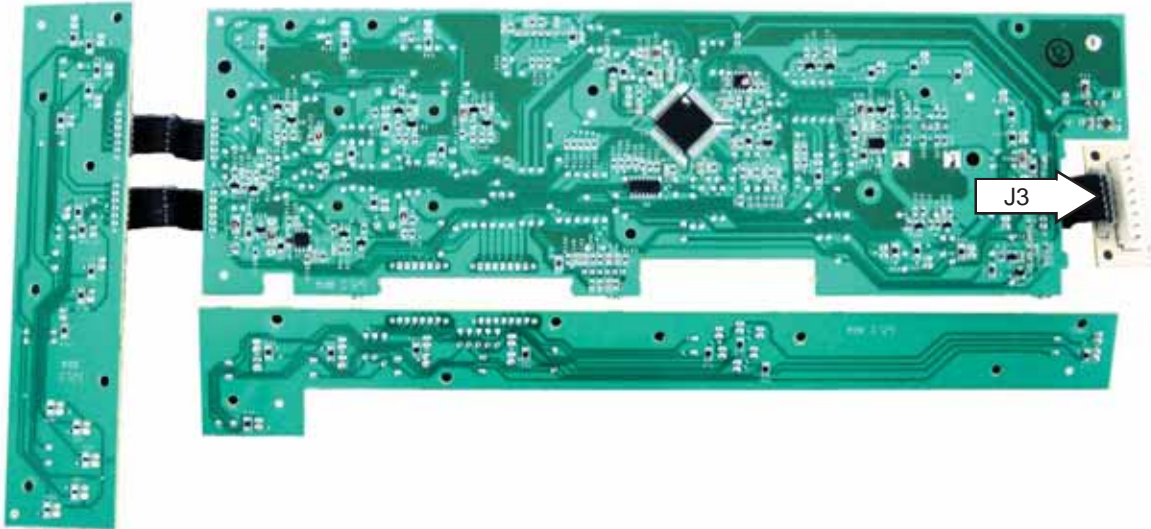

Front View

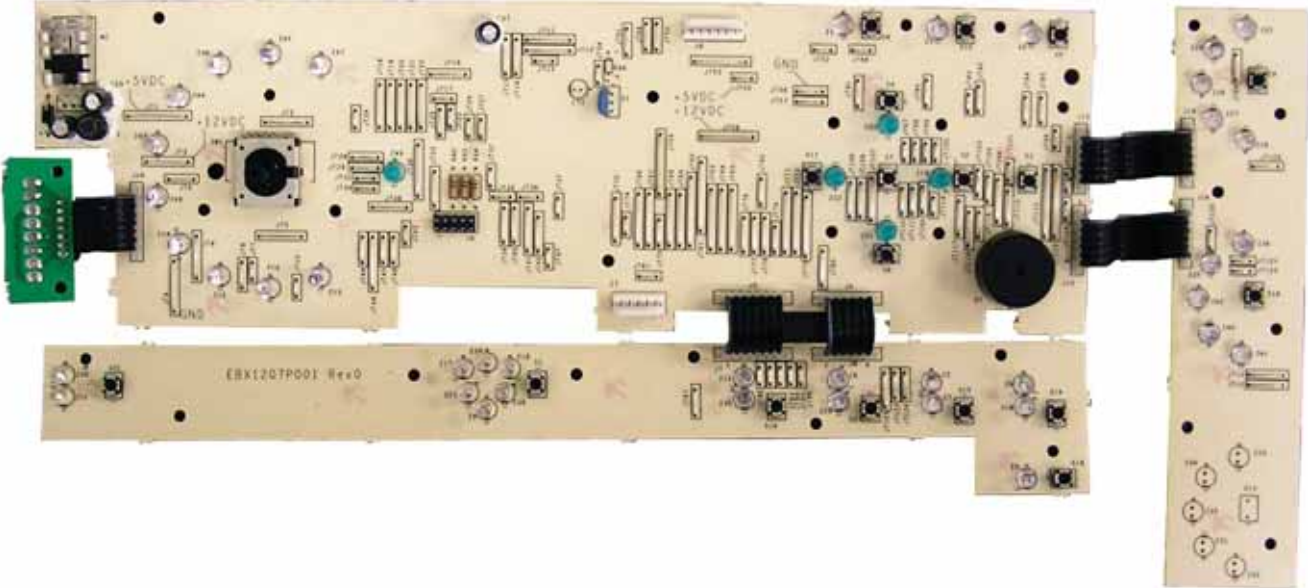

# Dryer Components

**WARNING:** Sharp edges may be exposed when servicing the dryer. Use caution to avoid injury. Wear Kevlar gloves or equivalent protection.

**Note:** Combined Phillips-head/square-drive recess screws are utilized throughout this appliance. Either Phillips or square-drive screwdrivers can be used to extract or install these screws.

## Control Panel

Removal of the control panel provides access to the control board assembly. The control panel is held in place with 1 screw behind the control knob and 4 key slots inside the control panel that engage 4 grommets (2 on each side) attached to the shield.

To remove the control panel:

**Note:** In the following step, the knob is held in place by 4 plastic clips and may require some effort to remove.

1. Remove the rotary knob by pulling straight out.



2. Remove the Phillips-head screw located inside the control knob recess.



3. Raise the control panel vertically to disengage the 4 key slots from the 4 grommets.



4. Remove the wire harness from the user interface board.

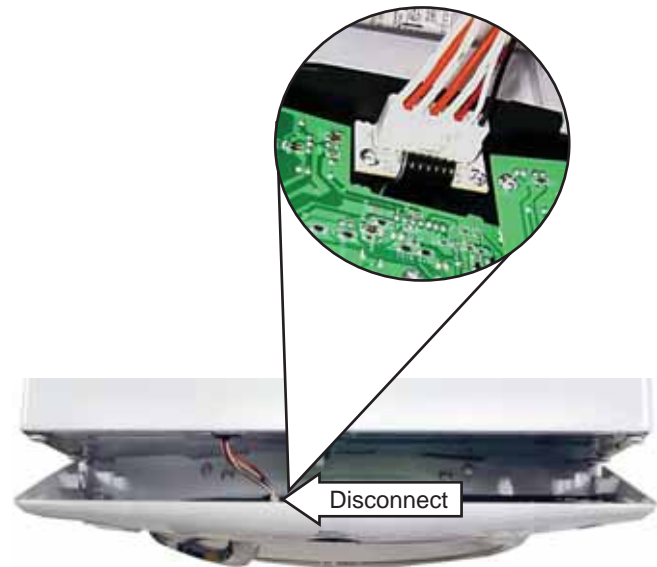



## Top Panel

Removal of the top panel provides access to the power board. The top panel is held in place with 3 Phillips-head screws in front and 2 tabs in back. The control panel must be removed to access the 3 Phillips-head screws. (See *Control Panel*.) After removing the 3 screws, the front of the top panel can be raised approximately 3 inches, then pulled forward to clear the rear tabs.



## Front Panel

Removal of the front panel provides access to the drum and drive belt. The front panel is held in place by 6 screws.

To remove the front panel:

1. Remove the control panel. (See *Control Panel*.)
2. Remove the top panel. (See *Top Panel*.)
3. Disconnect the door switch wire harness and the sensor rod wire harness to the power board.

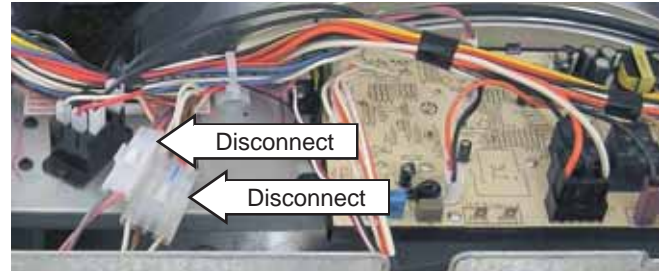

**Note:** In the following step, it may be necessary to raise the front of the dryer to gain access to the screws.

4. Loosen, but do not remove, the 2 Phillips-head screws that attach the bottom of the front panel to the frame.



5. Remove 2 Phillips-head screws from the shield and 2 Phillips-head screws from the top of the front panel.



6. Grasp the front panel on both sides, tilt it out, then lift the front panel vertically and remove.

## Air Duct Assembly

The air duct assembly houses the lint filter, drum seal, and the 2 sensor rods. It is located on the back side of the front panel.

**Note:** The sensor rods are part of the air duct assembly. To replace the sensor rods, the air duct assembly must be replaced.

To remove the air duct assembly:

1. Remove the control, top, and front panels. (See *Control Panel, Top Panel, and Front Panel.*)
2. Remove the 2 Phillips-head screws that attach the air duct assembly to the front panel.



3. Unhook the plastic tabs on each side of the air duct assembly and remove the air duct assembly.



**Note:** The drum seal can be replaced by extracting the seal from the channel located in the air duct assembly.



## Drum Slide Assembly

The drum slide assembly is located on the back side of the front panel and utilizes 4 drum slides. Two white outer slides are used as guides, and 2 dark color center (top) slides are used to support the weight of the drum. When replacing the slides, the dark-colored support slides must be used to replace the top support slides. Guide slides may also be replaced with support slides.

**Caution:** Do not replace the center (top) support slides with the white guide slides. Damage to the dryer will result.



To remove the drum slide assembly:

1. Remove the control, top, and front panels. (See *Control Panel, Top Panel, and Front Panel.*)
2. Remove the air duct assembly. (See *Air Duct Assembly.*)
3. Grasp the top of the drum slide assembly and pull down and inward to release from the 2 tabs located at the top of the front panel.



4. Remove the single Phillips-head screw and the drum light receptacle from the drum slide assembly.

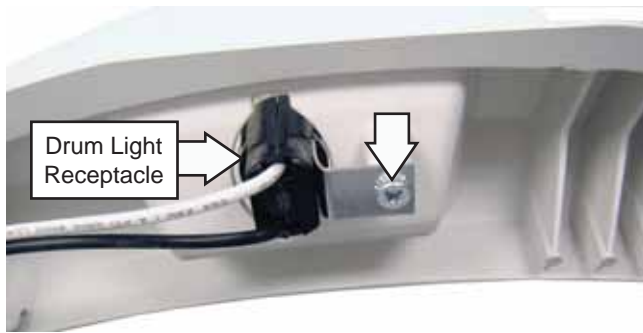

**Caution:** Upon reassembly, ensure that the door switch, drum light, and sensor wiring are retained and routed properly to avoid contact with the drum.

### Door Switch

The door switch is fastened to the front panel by 2 locking tabs (1 on each side). When using non-rack dry cycles, when the dryer door is closed, the switch will complete the drum motor circuit, allowing dryer operation. When the door is open, the switch will open the drum motor circuit, interrupting dryer operation. Opening the dryer door will also cause the door switch to close the drum light circuit, allowing the drum light to be energized.

When using the rack dry cycle, the drum motor circuit is not energized. The energized blower motor circuit is not affected by opening or closing the door. However, when using the rack dry cycle, opening the door or selecting **DRUM LIGHT** on the control panel will energize the rack dry interlock relay and open the heat circuit.

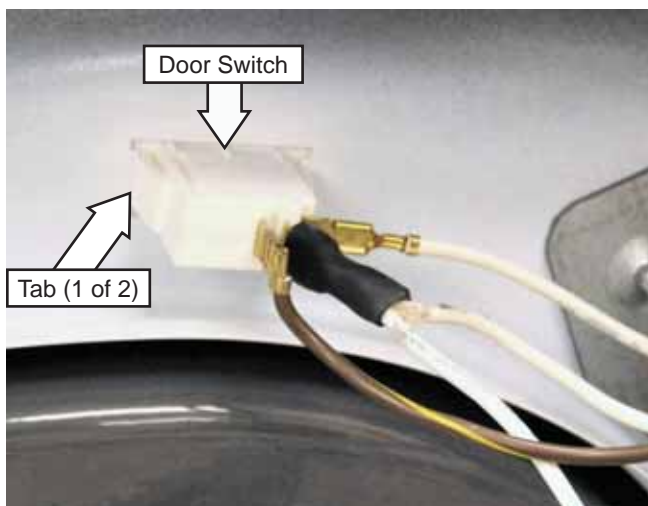

### Moisture Sensor

The moisture-sensing circuit consists of 2 sensor rods. They are mounted beneath the lint filter on the drum side of the air duct.

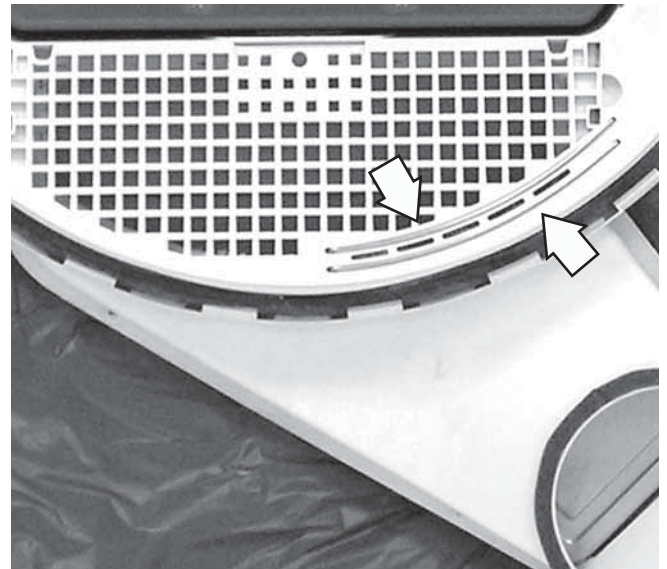

**Note:** The 2 sensor rods in the air duct assembly are not replaceable. To replace the sensor rods, replace the air duct assembly. (See *Air Duct Assembly*.)

- The sensor rods are connected to the main control board. The rods are spaced approximately ½-in. apart, which creates an open circuit to the control.
- The control board utilizes a low-voltage capacitor that charges to approximately 5 VDC when the circuit is open and discharges to less than 1 VDC when the circuit is shorted.
- When wet clothes tumble across the two rods, the clothes create a very low resistance between the rods, which discharges the capacitor.
- As the clothes become dry, their resistance value increases and the charge across the capacitor builds to approximately 5 VDC.
- Proper leveling of the dryer is vital for accurate sensor drying. If the front of the dryer is raised too high, clothes will tumble toward the rear of the drum, preventing contact with the sensor rods. This could produce a false dryness reading.

## Fuses

**WARNING:** Sharp edges may be exposed when servicing the dryer. Use caution to avoid injury and wear Kevlar gloves and sleeves or equivalent protection.

Certain models utilize fuses to protect components from damage. All fuses are located inside the dryer cabinet. (See *Component Locator Views*.) It is necessary to remove the drum to access the fuses. (See *Drum*.)

The gas models utilize a single 15-amp fuse installed in series with L1. The electric models employ two 30-amp fuses, 1 in series with L1 and 1 in series with L2. (See *Schematics and Wiring Diagrams*.)

Excessive current draw in any dryer circuit will open the fuse. An open fuse on the gas model will result in a totally inoperative dryer.

On the electric model, an open fuse on the L1 (red wire) will result in a totally inoperative dryer. An open fuse on the L2 (black wire) will allow the control panel to function, including the service test mode, but the dryer will not operate. Identify and correct the problem when replacing an open fuse.



**Note:** Open fuses will not be indicated by an error code.

## Drive Belt

**WARNING:** Sharp edges may be exposed when servicing the dryer. Use caution to avoid injury and wear Kevlar gloves and sleeves or equivalent protection.

The drive belt (Part #WE12M30) is a 5-rib belt and extends from under the drum motor pulley, over the top of the 2 idler pulleys, and around the perimeter of the dryer drum. Belt tension is maintained by a spring loaded dual idler pulley system and driven by a pulley attached to the drum motor shaft.

To remove the drive belt:

1. Remove the control, top, and front panels. (See *Control Panel, Top Panel, and Front Panel*.)
2. Reach under the left side of the drum. Grasp and rotate the drum counter-clockwise and run the belt off the front of the left pulley.

**Note:** The following call-out is illustrated with the drum removed to better demonstrate how to remove the drive belt.

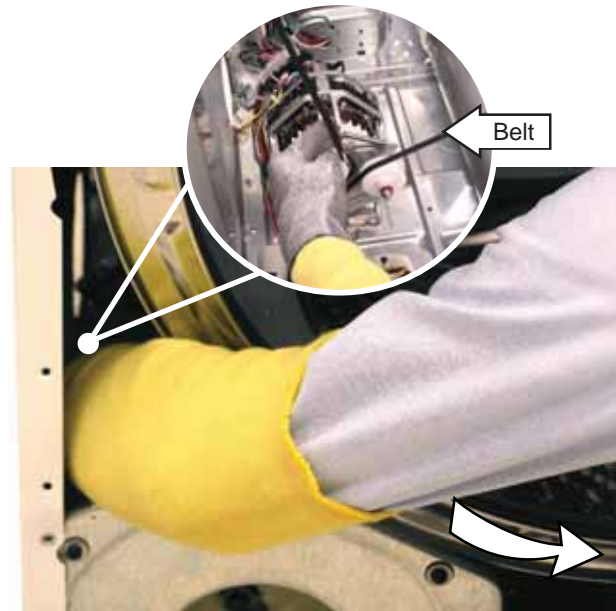

3. Lift the front of the drum up and guide the belt past the front of the cabinet base.



## To replace the drive belt:

1. Lift the front of the drum up, then place the belt in position around the circumference of the drum.
2. Push the left idler arm to the left approximately 1 inch.
3. Route the belt on the right side of the left idler pulley and under the motor pulley.

**Note:** The belt should be oriented so that the belt grooves contact the drum motor pulley.

4. Slowly release the left idler arm and push the right idler arm to the right.
5. Place the belt on the left side of the right idler pulley.
6. Slowly release the right idler arm until the belt is taut.

### Belt Installed on Pulleys

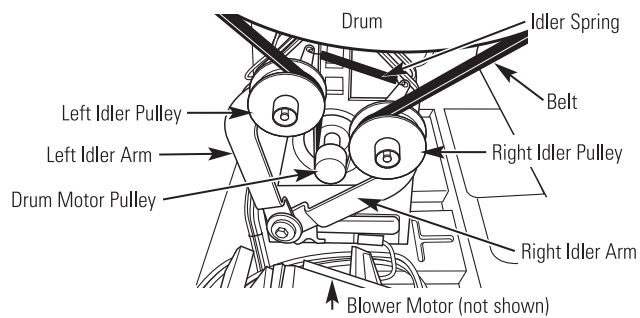

### Note

- Before installing the front panel, slowly rotate drum in both directions to ensure belt is aligned and not twisted.
- A belt instruction label is attached to the front of the cabinet base.

## Drum

The drum is made of 304 stainless steel and has three replaceable baffles.

### To remove the drum:

1. Remove the drive belt. (See *Drive Belt*.)
2. Remove either of the 2 Phillips-head screws that attach the front of the cabinet to the frame, then gently spread the sides apart to provide clearance for the drum.



3. Grasp the drum firmly at the 11 o'clock and 1 o'clock positions. Brace the bottom of the drum against your leg and maneuver the drum out of the cabinet.



## Drum Shaft and Bearing

The drum shaft is attached to the rear of the drum with three T-20 Torx screws. The bearing can be removed by pulling it off the shaft. The drum shaft and bearing fit into the bearing retainer in the center of the heater assembly (electric models) or diffuser assembly (gas models).

To access the drum shaft and bearing, it is necessary to remove the drum. (See *Drum*.)

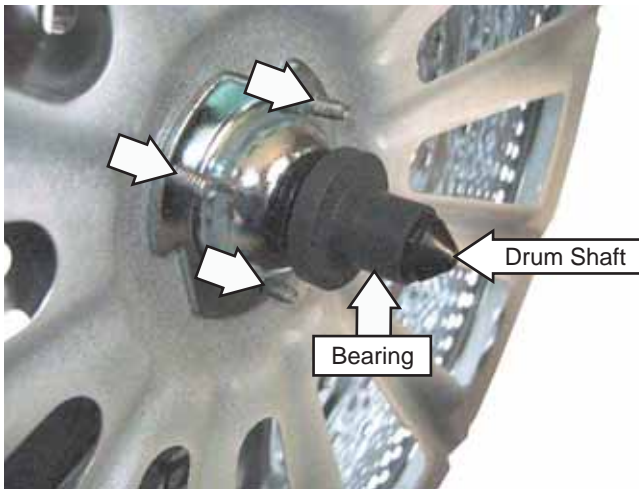

## Dual Idler Assembly

**WARNING:** Sharp edges may be exposed when servicing the dryer. Use caution to avoid injury. Wear Kevlar gloves or equivalent protection.

The dual idler assembly maintains proper tension on the drive belt to minimize belt slippage. The dual idler assembly consists of two idler pulleys that rotate on two idler arms. The pulleys are retained on the idler arms using cap nuts. The assembly is attached to the front of the motor baseplate with a 7/16-in. shoulder bolt.

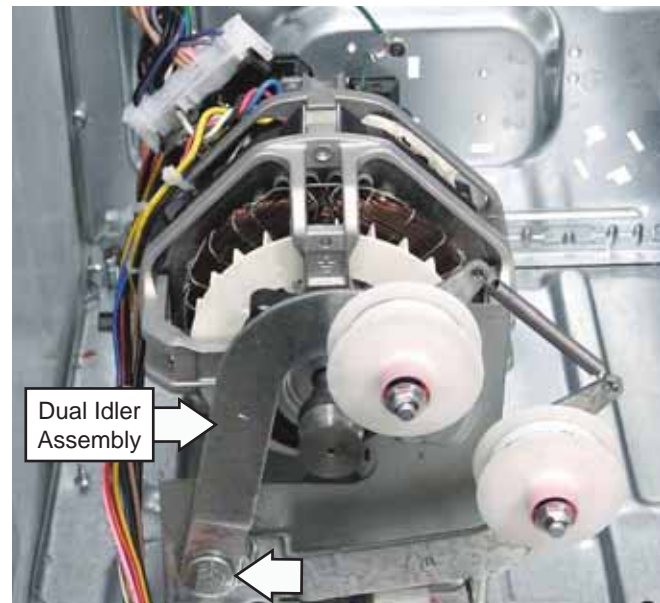

## Belt Switch

The belt switch is attached to the front of the drum motor baseplate with a Phillips-head screw. The switch is activated by the movement of the dual idler assembly. If the drive belt breaks or comes off of the idler pulleys, the belt switch opens power to the drum motor, interrupting dryer operation. The drum must be removed to access the belt switch and wiring. (See *Drum*.)

**Note:** The drum lamp will operate with an open belt switch.

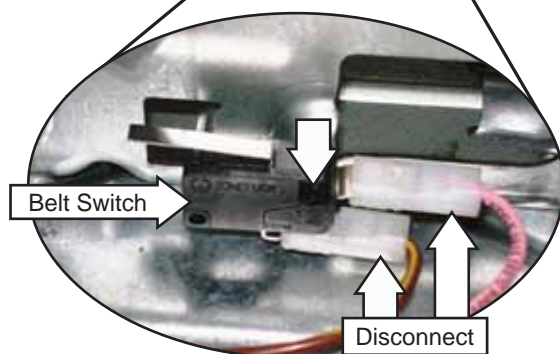
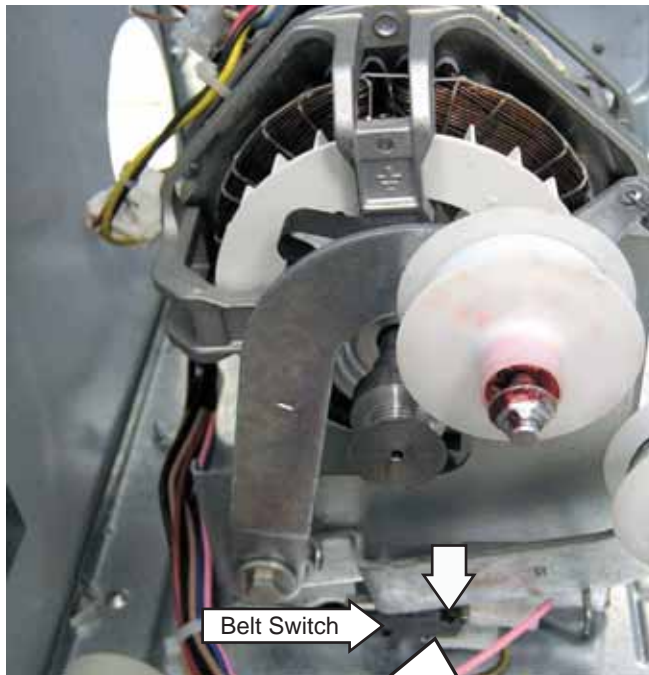

## Drum Motor

The drum motor is a single-speed, 120-VAC, 1/4-hp, 5.2-amp rated motor with an automatic reset overload protector. The overload protector is an internal component of the motor and cannot be replaced separately. The motor contains a centrifugal switch that serves two purposes:

- Disengages the motor start winding at M6.
- Closes the circuit contacts for the heat source. (Heat source contacts are M1 and M2.)

The switch is an internal component of the motor and cannot be replaced separately.

**To remove the drum motor:**

1. Remove the drum. (See *Drum*.)
2. Disconnect the motor wiring harness from the back of the motor.

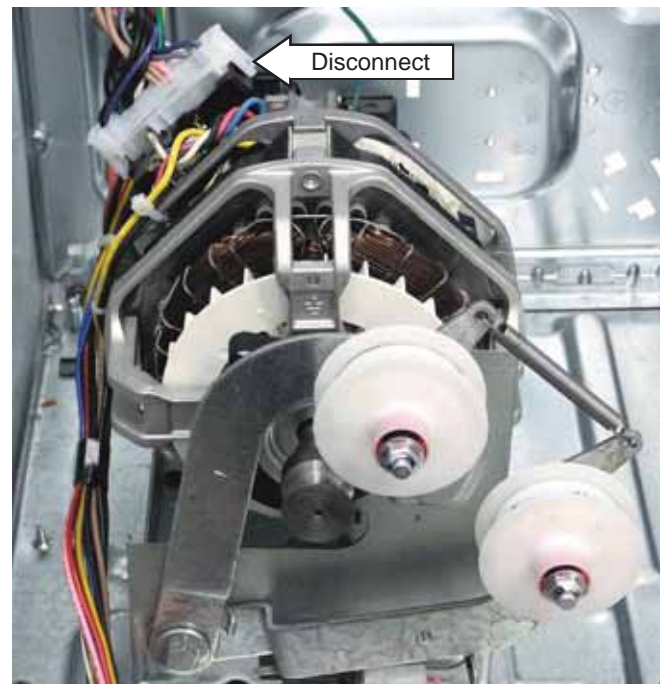

3. Compress then remove the front and rear motor straps from the motor baseplate.

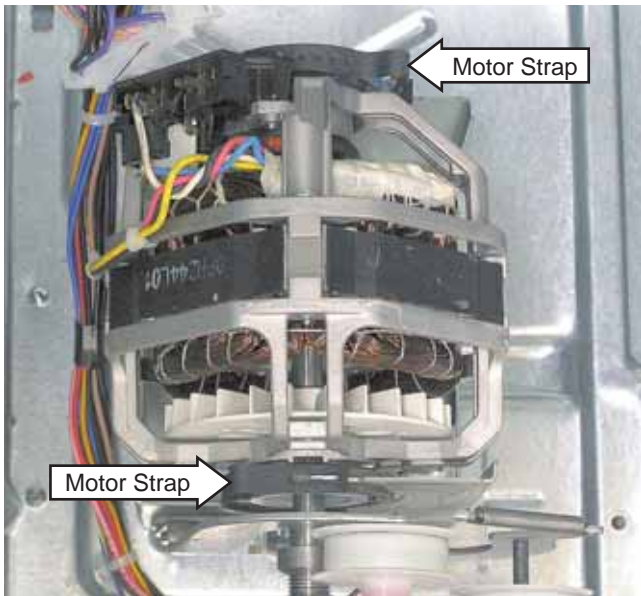

4. Move the dual idler pulley assembly to the left, then remove the drum motor from the motor bracket.
5. Place the drum motor (pulley side up) on the dryer base plate, then disconnect the wire harness.

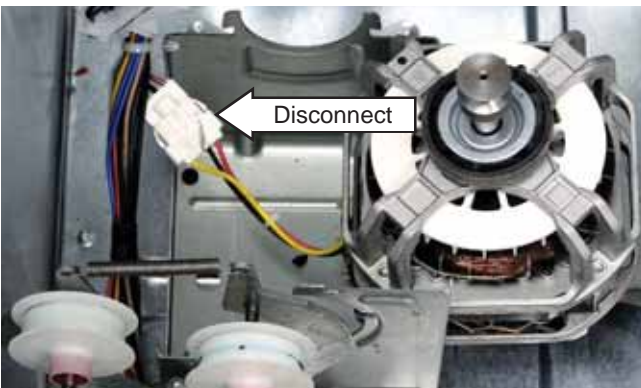

**Note:** When installing the drum motor, ensure the tab on the motor coupling is engaged in the slot on the motor bracket before installing the front and rear motor straps.



## Blower Motor

The blower motor is a 120-VAC, 1/8-hp, 1.6-amp rated motor. The tachometer at the back of the motor provides speed input to the main board.

Motor resistance values:

Start winding = approximately 5  $\Omega$

Run winding = approximately 4  $\Omega$

The blower motor is attached to a plate that is held in place by 5 Phillips head screws and two tabs that engage 2 slots in the dryer floor. The blower wheel is held to the motor shaft by a blower wheel clamp.

**To remove the blower motor:**

1. Remove the drum. (See *Drum*.)
2. Loosen the 3/8-in. hex-head screw that secures the blower wheel clamp to the motor shaft.
3. Remove the 2 Phillips-head screws that attach the motor plate to the frame.

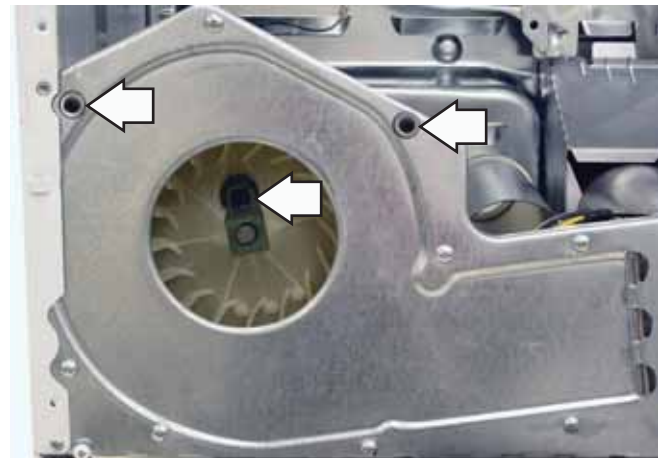

4. Remove the Phillips-head screw that attaches the outlet control backup thermostat to the blower housing.

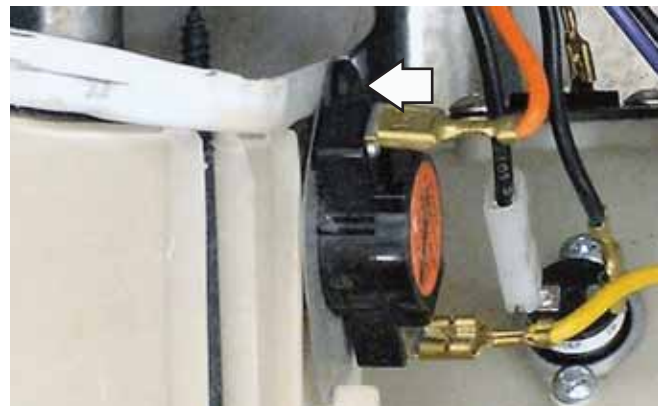

(Continued Next Page)



5. Remove the 3 Phillips-head screws that attach the motor plate to the dryer floor.

**Note:** When installing the 3 Phillips-head screws, ensure the ground wire is attached with the right-side vertical screw.

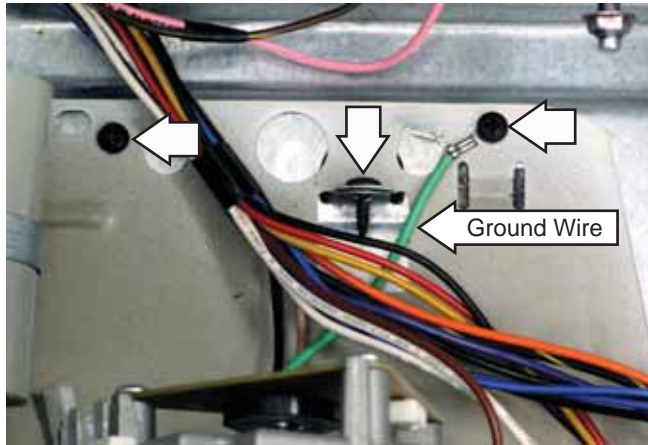

6. Grasp the blower wheel and slide the motor and motor plate toward the rear, releasing the tabs on the front of the motor plate from slots in the dryer floor.



7. Tilt the assembly toward the rear then remove the 3 Phillips-head screws that attach the motor to the motor plate.

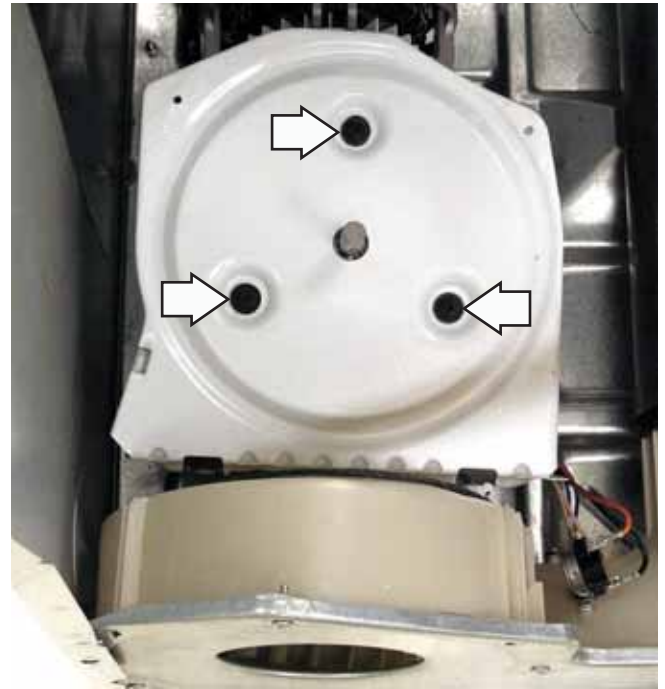

8. Disconnect the 2 wire harnesses from the blower motor and the 2 wires from the drum motor capacitor.

#### **Note**

1. When installing the blower motor to the motor plate, install the motor with the motor harness terminals at the 10 o'clock position.
2. When installing the blower motor and plate to the dryer, first orient the flat part of the motor shaft, blower wheel hub, and clamp in the downward position. Slide the motor shaft into the blower wheel. Tighten the blower wheel clamp before positioning and installing the Phillips-head screws that attach the motor plate to the frame and floor of the dryer.

## Blower Wheel

The blower wheel is held to the blower motor shaft with a clamp. To remove the blower wheel, it is not necessary to remove the blower motor from the blower housing. The blower wheel can be removed by removing the blower housing from the frame. The blower housing is attached to the frame with 9 Phillips-head screws and 3 tabs.

To remove the blower wheel:

1. Remove the drum. (See *Drum*.)
2. Remove the Phillips-head screw located inside the outlet of the exhaust pipe. Separate the exhaust pipe from the blower housing.

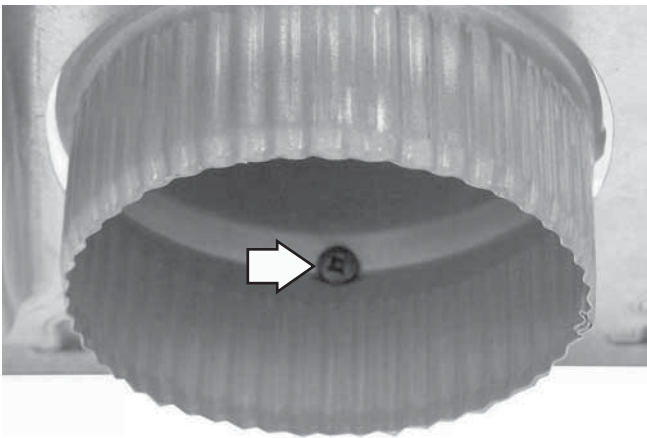

3. Remove the 3 Phillips-head screws that attach the motor plate to the dryer floor.

**Note:** When installing the 3 Phillips-head screws, ensure the ground wire is attached with the right-side vertical screw.

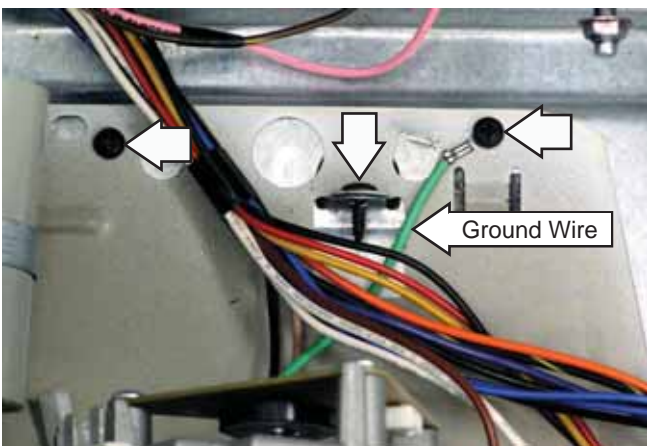

4. Remove the 9 Phillips-head screws that attach the motor plate and the blower housing to the frame.
5. Slide the blower housing and blower motor assembly to the right, then slide it toward the rear of the dryer.

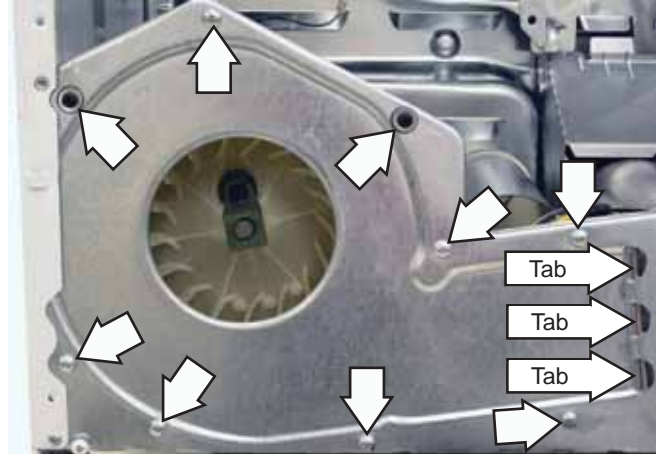

6. Tilt the front of the assembly up and loosen the 3/8-in. hex-head screw that secures the blower wheel clamp to the motor shaft.



7. Pull the blower wheel off the motor shaft.

## Heater Assembly

**WARNING:** Sharp edges may be exposed when servicing the dryer. Use caution to avoid injury. Wear Kevlar gloves or equivalent protection.

The heater assembly is located behind the drum. It consists of 2 open coils fastened to a single housing. The inner coil is controlled by a relay on the power board. The outer coil is controlled by a triac attached underneath the power board support. When energized, each coil draws approximately 12.5 amps at 240 VAC. Each coil has an approximate resistance value of 19.2  $\Omega$ .

To access the heater assembly, it is necessary to remove the drum. (See *Drum*.) Lead wires can then be removed from the coils, inlet safety thermostat, inlet control thermistor, and high limit thermostat. (See *Component Locator Views*.) The heater assembly is attached to the cabinet with 4 Phillips-head screws.

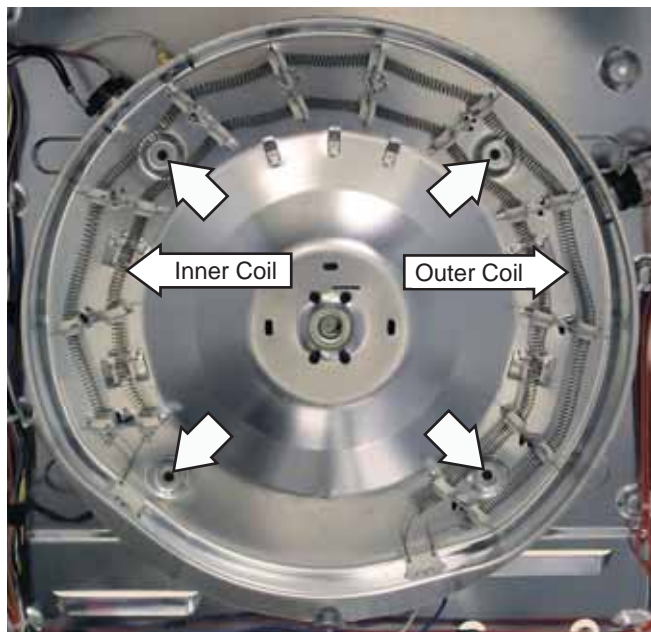

## Triac

The triac is mounted beneath the power board support located under the top panel.

**Note:** The replacement triac comes with heatsink.

To remove the triac:

1. Remove the control and top panels. (See *Control Panel* and *Top Panel*.)
2. Mark and remove the three wires from the triac.
3. Remove the 2 Phillips-head screws that attach the triac heatsink to the power board support.

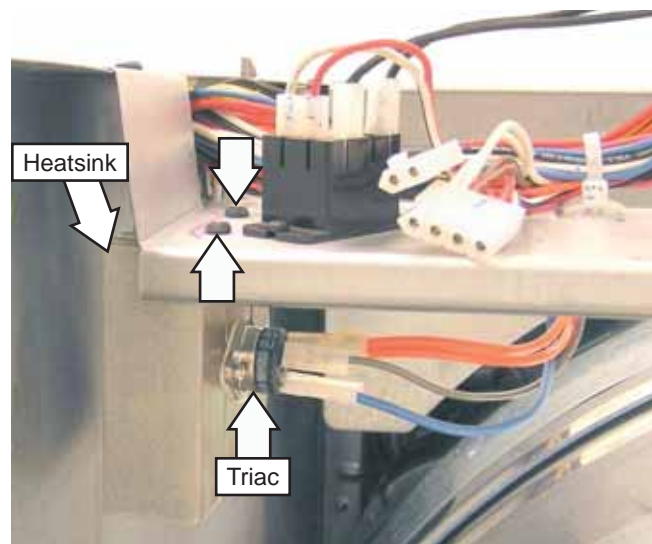

MT1 - Orange wires

MT2 - Blue wire

Gate - Grey wire

## Electric Dryer Element Operation - Normal Heat Cycle

- To measure electric heater amperage, locate and read current on the orange wire connecting the high limit thermostat terminal 3 to MT1 on the triac.
- To measure triac gate voltage (VDC), read between J4 Pin 3 (logic ground) and board location JT27.

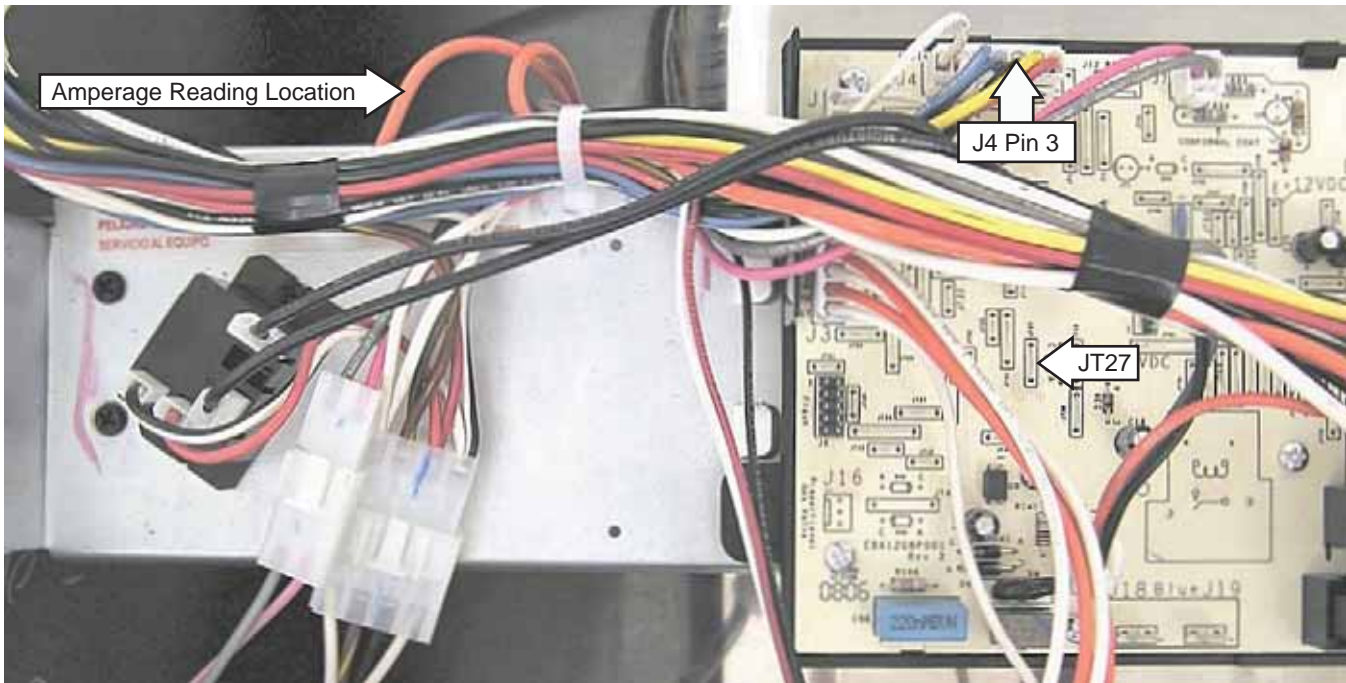

- The K8 relay closes J10 Pin 1 to J10 Pin 5. This energizes the inner coil. At the same time the triac is gated with 4.8 VDC. MT1 to MT2 close, turning on the outer coil. At this time both coils are energized and the heat system is drawing approximately 24 amps.
- As the drum temperature begins to rise, the triac gate voltage begins to pulsate between 4.8 and 0 VDC. The current draw of the outer coil begins to drop. The heat system is now drawing somewhere between 16 and 20 amps.

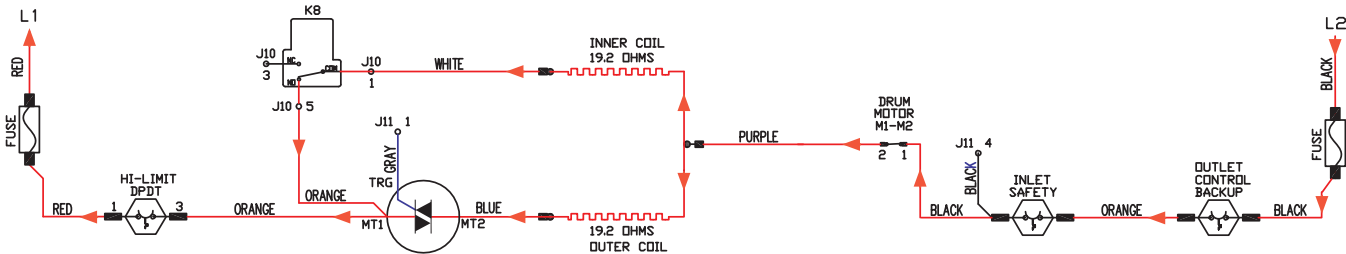

- Triac gate voltage finally drops to 0 VDC. The outer coil is off. The inner coil is still operating. The system is now drawing approximately 12 amps.

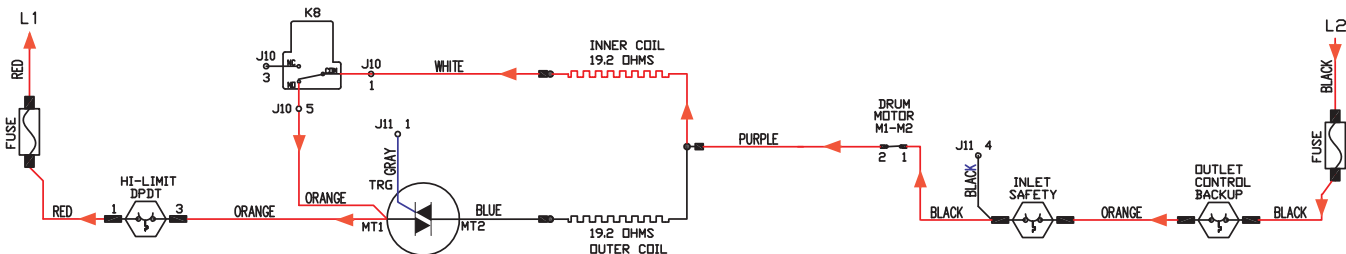

(Continued Next Page)

- As the drum heats up further, relay K8 opens J10 Pin 1 to J10 Pin 5 and cycles off the inner coil. The heat system is now drawing 0 amps.

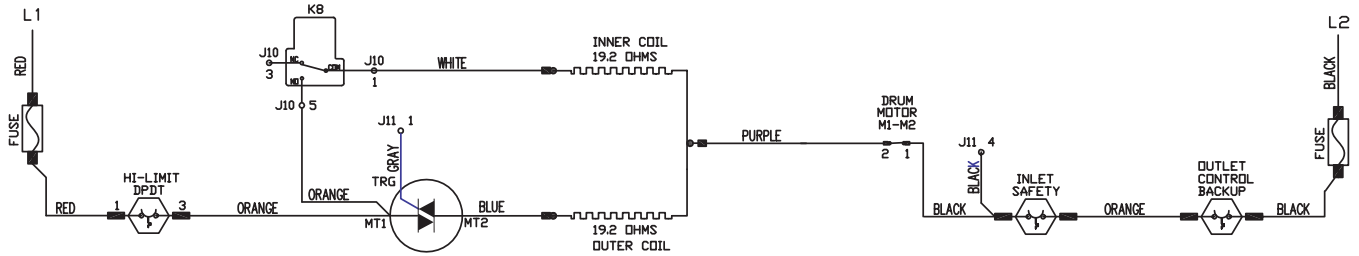

- The drum temperature begins to drop and at that time the triac gate voltage, again, begins to pulsate 0 to 4.8 VDC.
- The outer coil is energized and draws approximately 7 amps. This outer coil current begins to climb slowly towards 11 amps.

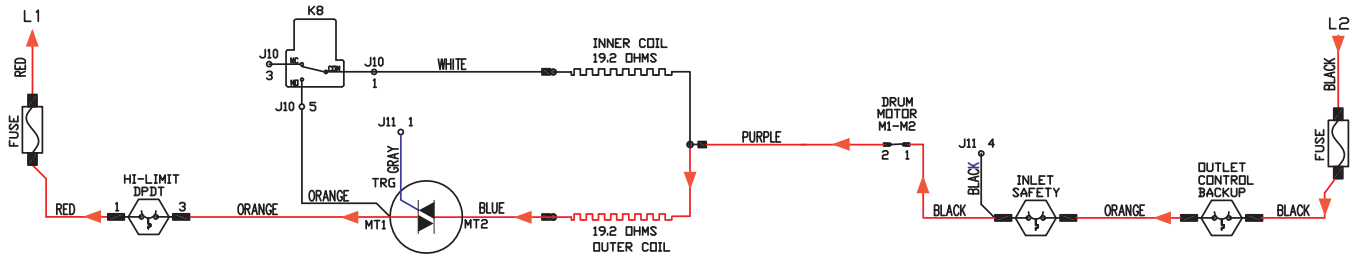

- At this point, relay K8 again closes J10 Pin 1 to J10 Pin 5, turns on the inner coil, and the triac gate voltage drops to 0 VDC and the outer coil turns off. The inner coil again draws approximately 12 amps.

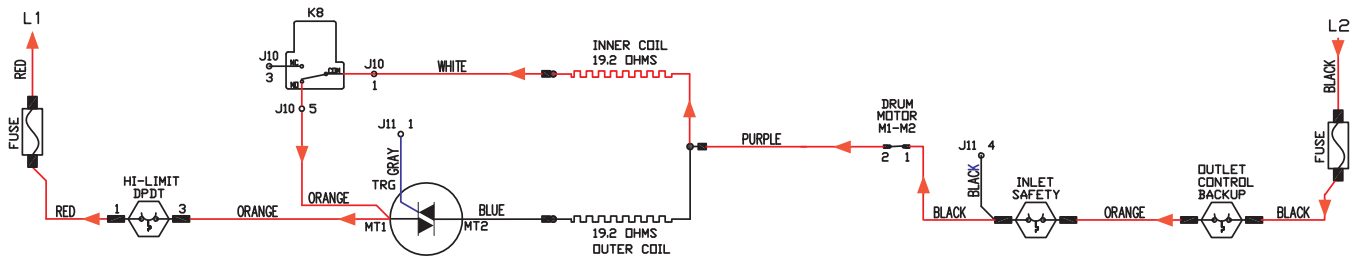

- This cycling pattern continues throughout the drying period.

## Burner Assembly and LP Conversion

The burner assembly consists of the gas valve coils, gas valve, burner, and inlet pipe.

To convert the dryer from natural gas to LP gas, the burner assembly must be replaced. The burner cannot be converted to LP gas. Refer to conversion kit #14-A048.

## Gas Valve Coils

The burner assembly has a gas valve that utilizes 4 coils. A double coil (safety and booster coils combined) and a single main coil are located on top of the gas valve in front of the combustion chamber opening. A half-power coil is located on the front of the gas valve. All coils can be replaced separately.

Gas valve coil assembly resistance values:

- Safety coil terminals - 1400  $\Omega$
- Booster coil terminals - 580  $\Omega$
- Main coil terminals - 1300  $\Omega$

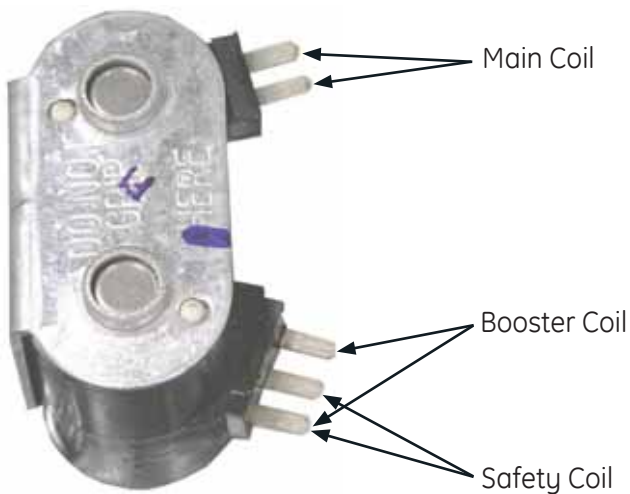

The half-power coil has an approximate resistance of 1K  $\Omega$ .

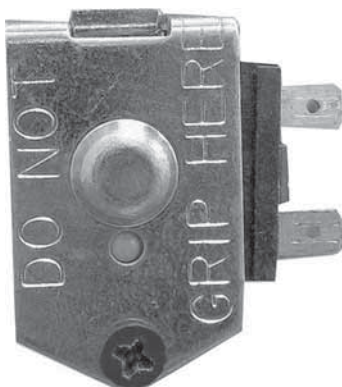

To remove the double and main coils:

1. Remove the drum. (See *Drum*.)
2. Disconnect the wire harness from both coils.

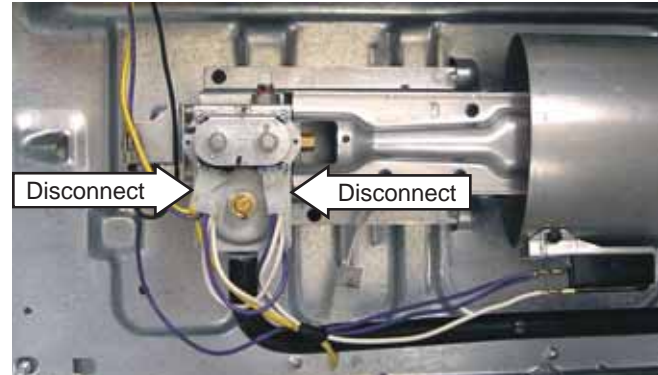

3. Note the position of the locator pins inserted in the coil bracket.
4. Remove the 2 Phillips-head screws that attach the coil bracket to the valve body.

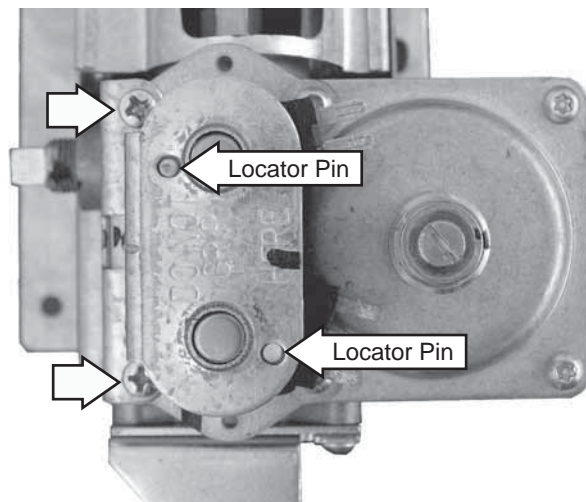

5. Lift the bracket vertically. Lift coils to remove.

**Note:** Upon reassembly, ensure the locator pins are inserted into the holes provided in the coil bracket.

### To remove the half-power coil:

1. Remove the drum. (See *Drum*.)
2. Disconnect the 2 wires from the half-power coil.
3. Note the position of the locator pin inserted in the coil bracket.
4. Remove the Phillips-head screw and the coil bracket that holds the coil to the valve body.

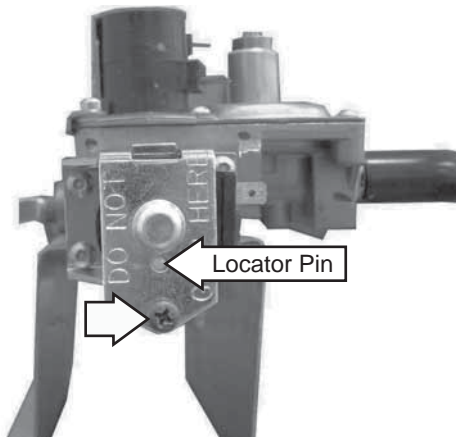

**Note:** Upon reassembly, ensure the locator pin is inserted into the hole provided in the coil bracket.

### Gas Valve

The burner assembly utilizes a 2 stage gas valve that ensures better heat control:

- First stage – low flame – low heat
- Second stage – normal flame – high heat
- Control board regulates valve operation for proper heat levels

The gas valve is attached to a bracket located in the bottom, right, front corner of the dryer cabinet.

### To remove the gas valve:

1. Shut the gas off to the unit.
2. Disconnect gas supply line from the burner inlet pipe.
3. Remove the drum. (See *Drum*.)
4. Disconnect the coil wire harness from each coil and the 2 wires from the half-power coil.
5. Disconnect the ignitor wire harness and the 2 wires from the flame detector.

6. Remove the 2 Phillips-head screws that attach the gas valve bracket to the dryer floor.
7. Pull the bracket toward the front of the dryer to disengage tabs from dryer floor.

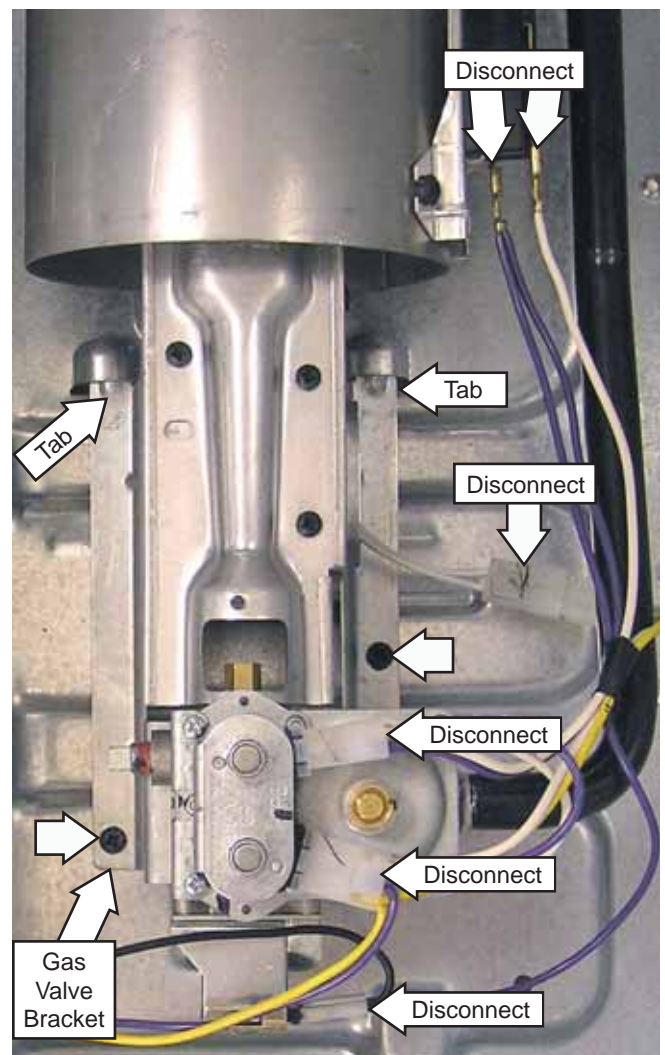

8. Remove the coils from the gas valve. (See *Gas Valve Coils*.)
9. Turn the bracket over. Remove the 3 Phillips-head screws that attach the gas valve to the gas valve bracket.

**Caution:** The ignitor is very fragile. To prevent breaking the ignitor, care must be taken when installing the gas valve.

**Note:** Upon reassembly, ensure the gas valve bracket is inserted under the 2 tabs located in the dryer floor.

## Ignitor

**WARNING:** Sharp edges may be exposed when servicing the dryer. Use caution to avoid injury. Wear Kevlar gloves or equivalent protection.

The ignitor is located at the end of the burner assembly in the combustion chamber opening and has a maximum rating of 4 amps. The ignitor has an approximate resistance value of 300 to 500  $\Omega$ .

The ignitor is attached to the gas valve bracket with a Phillips-head screw. To access the ignitor, it is necessary to remove the burner assembly. (See *Gas Valve*, steps 1 through 7.)

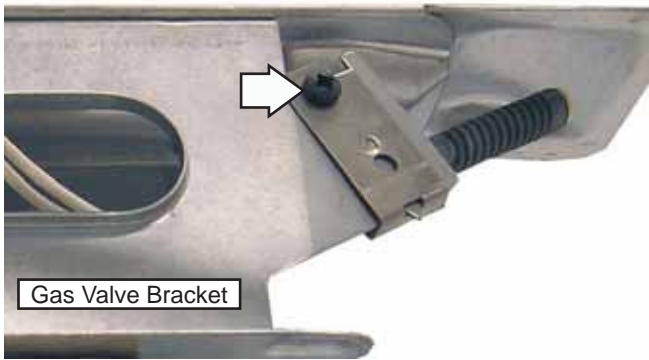

**Caution:** The ignitor is very fragile. To prevent breaking the ignitor, care must be taken when installing the burner assembly.

## Flame Detector

The flame detector is attached to the right side of the combustion chamber.

To remove the flame detector:

1. Remove the drum. (See *Drum*.)
2. Disconnect the 2 wires from the flame detector.
3. Remove the Phillips-head screw that holds the flame detector to the combustion chamber.



4. Remove the flame detector from the tab at the bottom.

**Note:** Upon reassembly, ensure the tab at the bottom of the flame detector is inserted into the slot located on the combustion chamber.



## Ignitor Circuit Operation

The glo-bar ignitor circuit is made up of the following components: a gas valve with safety and main valves, ignitor, and a flame detector. The safety valve is actuated by a double coil that comprises a safety coil (resistance approximately 1400 ohms) and a booster coil (resistance approximately 580 ohms). Both coils are needed to open the safety valve. Once energized, the safety coil alone will hold the valve open. The main valve has a single coil (resistance approximately 1300 ohms).

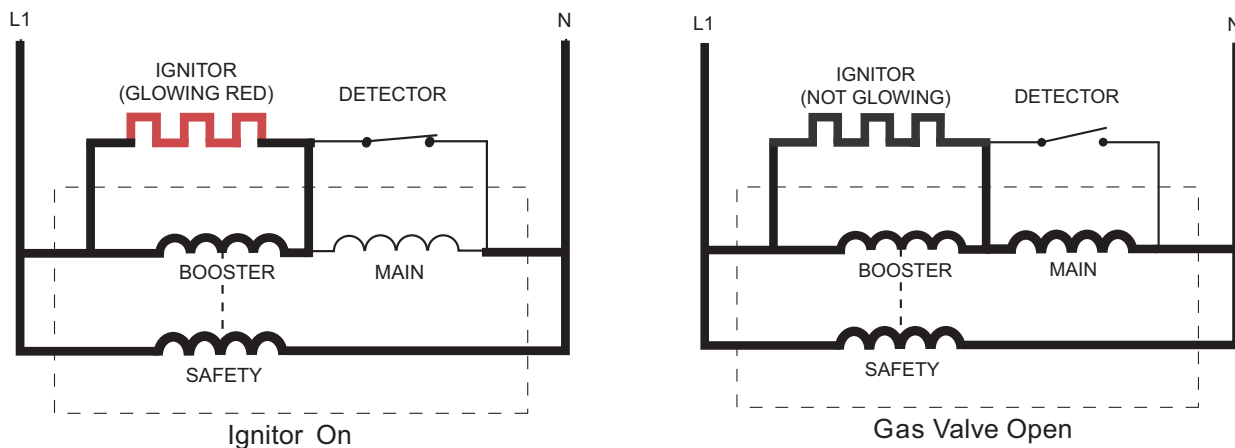

The flame detector (< 1 ohm) is mounted on the combustion chamber. It is normally in the closed position (N.C.). The flame detector is opened by the radiant heat produced by the glo-bar and once open, the flame detector will be held open by the radiant heat produced by the gas flame.

When the control system calls for heat, the following circuits are energized:

1. N- through detector, ignitor, outlet control backup, inlet safety thermostats to L1
2. N- through detector, booster coil, outlet control backup, inlet safety thermostats to L1
3. N- through safety coil and outlet control backup, inlet safety thermostats to L1

When the glo-bar is heating, the booster and safety coils are both energized and will open the safety valve. The main valve is closed as its coil is bypassed by the N.C. flame detector. When the glo-bar reaches ignition temperature, in approximately 60 seconds or less, the flame detector is heated and opens, which places the main coil in series with the glo-bar. The main valve opens, allowing gas to flow into the combustion chamber and ignite. The main coil, now in series with the glo-bar, causes the glo-bar to cool down. However, the flame detector is held open by the radiant heat from the gas flame. The booster coil is now also in series with the main coil and is essentially inoperative. Should a momentary power failure occur, the gas valve will shut off and an attempt to restart will not occur until the flame detector cools and resets, in approximately 30 seconds.

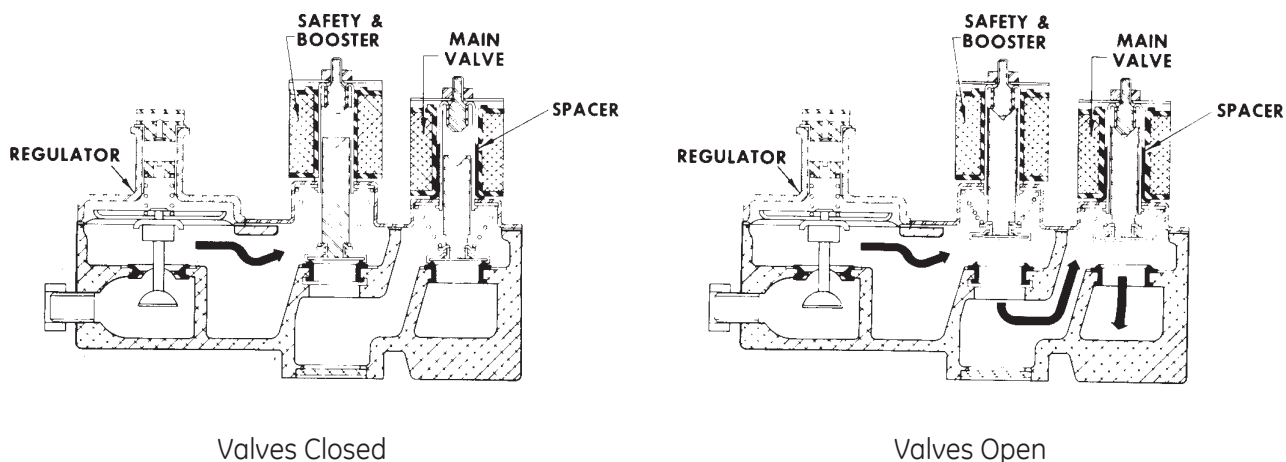

## Rack Dry Calrod® Element

The rack dry Calrod® element is attached to the inside of the combustion chamber. The element is rated at 700 watts and has an approximate resistance value of 20  $\Omega$ .

### Note

- The Calrod can be removed without shutting off the gas supply or removing the gas valve.
- Due to possible damage to the ignitor during Calrod replacement, always install the new ignitor supplied with the replacement Calrod.

### To remove the rack dry Calrod element:

1. Remove the drum. (See *Drum*.)
2. Disconnect the 2 wires from the Calrod.
3. Disconnect the 2 wires from the flame detector.
4. Remove the 3 Phillips-head screws that attach the burner to the top of the gas valve bracket.
5. Loosen the Phillips-head screw holding the Calrod to the combustion chamber.

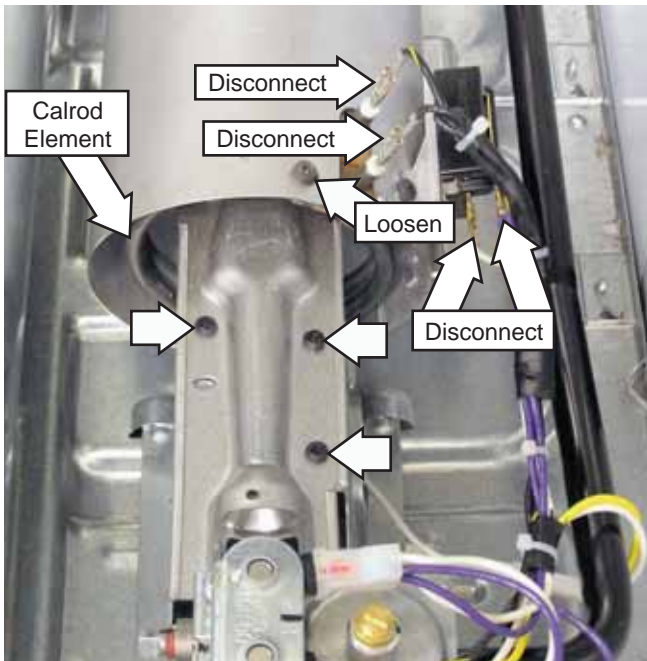

6. Position the Calrod to access the 2 Phillips head screws holding the combustion chamber to the dryer floor, then remove both screws.

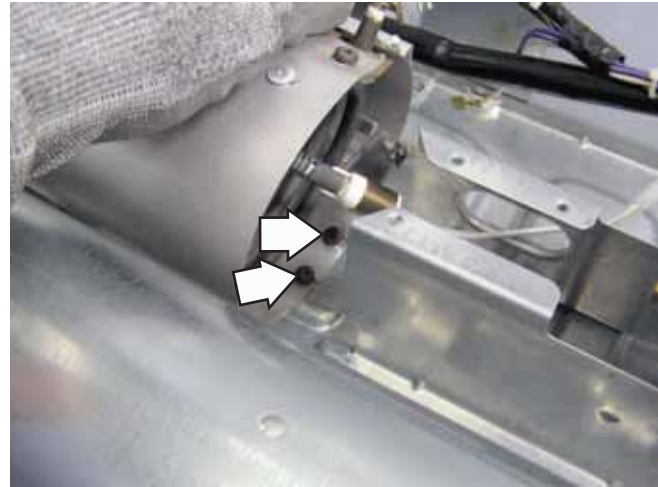

7. Pull the combustion chamber forward until it comes out of the transition duct, then lift it out with the Calrod attached.



8. Remove the Phillips-head screw holding the Calrod to the combustion chamber.

### Calrod Removed



## Inlet Safety Thermostat

On electric models, the inlet safety thermostat is located on the top left area of the heater housing, to the left of the inlet control thermistor. On gas models, the inlet safety thermostat is located on the right side of the diffuser, above the inlet control thermistor. The thermostat monitors incoming air temperature.

If the thermostat reaches a temperature beyond its maximum temperature rating, it will trip and disable power to the heating elements (electric models) or burner assembly (gas models).

On electric dryers, the inlet safety thermostat opens at 210°F (99°C) and will automatically reset at 180°F (82°C). On gas dryers, the inlet safety thermostat opens at 300°F (149°C) and will automatically reset at 260°F (127°C).

### To remove the inlet safety thermostat:

1. Remove the drum. (See *Drum*.)
2. Disconnect the 2 wires from the inlet safety thermostat.
3. Remove the Phillips-head screw that attaches the inlet safety thermostat to the heater assembly or diffuser.
4. Lift and slide the thermostat from the heater assembly or diffuser.

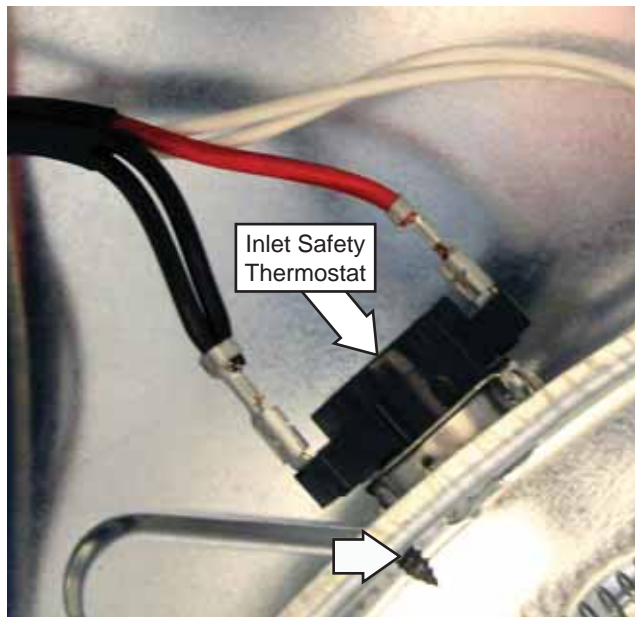

Electric Model Shown

## Inlet Control Thermistor

On electric models, the inlet control thermistor is located on the top left area of the heater housing, to the right of the inlet safety thermostat. On gas models, the inlet control thermistor is located on the right side of the diffuser, below the inlet safety thermostat. The thermistor monitors incoming air temperature and relays the information to the power board.

The thermistor has a negative coefficient. As the temperature increases, the thermistor's resistance decreases.

Inlet control thermistor approximate resistance values:

- 120 K  $\Omega$  at 69°F (20°C)
- 100 K  $\Omega$  at 77°F (25°C)
- 80 K  $\Omega$  at 86°F (30°C)
- 29 K  $\Omega$  at 130°F (54°C)
- 19 K  $\Omega$  at 145°F (63°C)

Operation of the inlet control thermistor can be checked by using the Inlet Thermistor test in service test mode. (See *Service Test Mode*.)

Specific failures associated with the inlet control thermistor can initiate error codes E2 and E4. (See *Service Test Mode*.)

### To remove the inlet control thermistor:

1. Remove the drum. (See *Drum*.)
2. Disconnect the 2 wires from the inlet control thermistor.
3. Remove the Phillips-head screw that attaches the inlet control thermistor to the heater assembly or diffuser.
4. Lift and slide the thermistor from the heater assembly or diffuser.

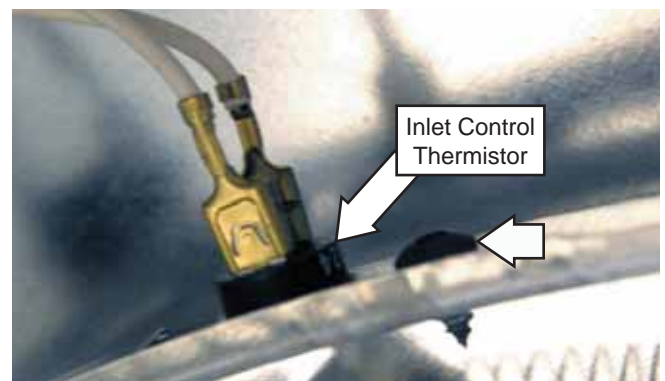

Electric Model Shown

## High Limit Thermostat

On electric models, the high limit thermostat is located on the top right area of the heater housing. On gas models, the high limit thermostat is located on the lower left side of the diffuser. The high limit thermostat monitors incoming air temperature.

If the thermostat reaches a temperature beyond its maximum temperature rating, it will trip and disable power to the elements or burner assembly.

For the electric models, the high limit thermostat opens at 315°F (157°C) and will automatically reset at 250°F (121°C).

For the gas model, the open temperature is 180°F (82°C) and the close temperature is 165°F (74°C).

To remove the inlet high limit thermostat:

1. Remove the drum. (See *Drum*.)
2. On electric models, mark and disconnect the 2 orange wires and the two red wires from the high limit thermostat. On gas models, disconnect the 2 wires from the high limit thermostat.
3. Remove the 2 Phillips-head screws that attach the high limit thermostat to the heater assembly or diffuser.
4. Slide the thermostat from the heater assembly or diffuser.

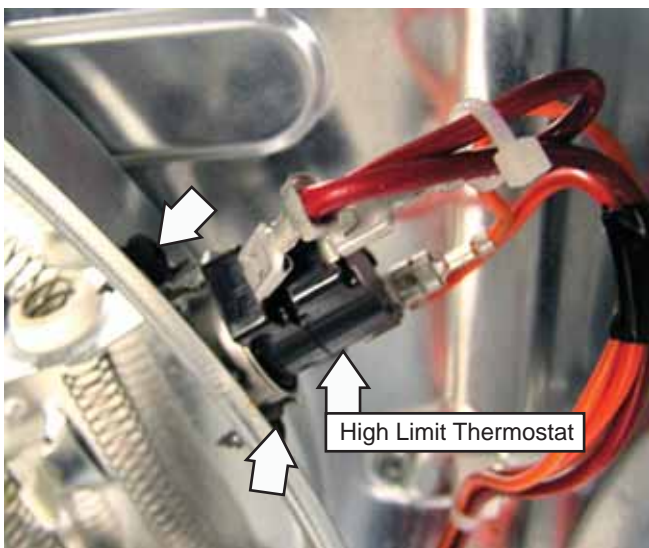

Electric Model Shown

## Outlet Control Thermistor

The outlet control thermistor is located on the lower rear area of the blower housing. It is below the outlet control backup thermostat and the rack dry thermostat. The outlet control thermistor measures outgoing air temperature and provides temperature change information to the power board. The outlet control thermistor has the same resistance values as the inlet control thermistor. (See *Inlet Control Thermistor*.)

Operation of the outlet control thermistor can be checked by using the Outlet Thermistor test in service test mode. (See *Service Test Mode*.)

Specific failures associated with the outlet control thermistor can initiate error codes E3 and E5. (See *Service Test Mode*.)

To remove the outlet control thermistor:

1. Remove the drum. (See *Drum*.)
2. Disconnect the 2 wires from the outlet control thermistor.
3. Remove the 2 Phillips-head screws that attach the outlet control thermistor to the blower housing.

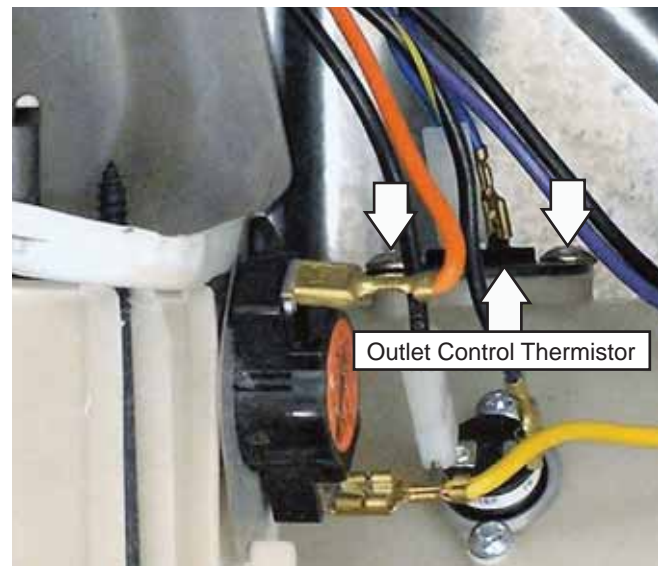

Electric Model Shown

## Outlet Control Backup Thermostat

The outlet control backup thermostat is located on the upper, rear area of the blower housing. It is above the outlet control thermistor and the rack dry thermostat. The outlet control backup thermostat monitors the outgoing air temperature.

If the thermostat reaches a temperature beyond its maximum temperature rating, it will trip and disable power to the heating elements or burner assembly.

The outlet control backup thermostat opens at 165°F (74°C) and will automatically reset at 155°F (68°C).

### To remove the outlet control backup thermostat:

1. Remove the drum. (See *Drum*.)
2. Disconnect the 2 wires from the outlet control backup thermostat.
3. Remove the Phillips-head screw that attaches the outlet control backup thermostat to the blower housing.

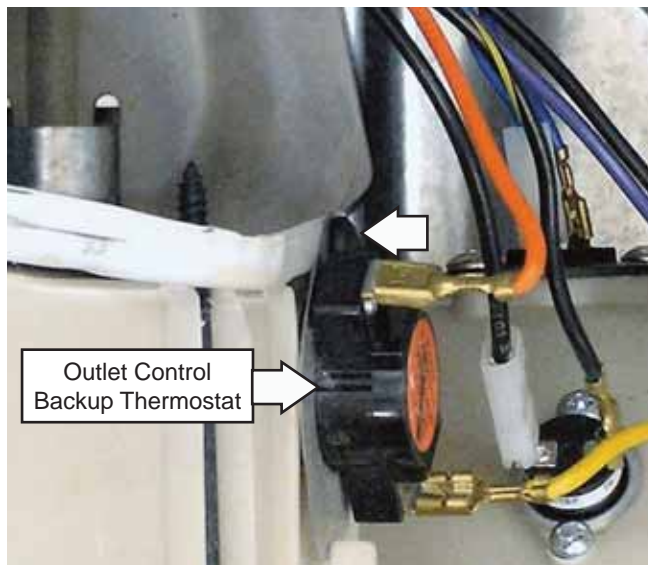

Electric Model Shown

## Rack Dry Thermostat

The rack dry thermostat is located on the upper rear area of the blower housing. It is above the outlet control thermistor. The rack dry thermostat monitors the outgoing air temperature.

If the thermostat reaches a temperature beyond its maximum temperature rating, it will trip and disable power to the heating elements or rack dry Calrod element.

The rack dry thermostat opens at 130°F (54°C) and will automatically reset at 115°F (46°C).

**Note:** On electric models, if the drum light is activated by selecting *DRUM LIGHT* on the control panel during the rack dry cycle, the rack dry interlock relay will open and heater operation will stop.

### To remove the rack dry thermostat:

1. Remove the drum. (See *Drum*.)
2. Disconnect the 2 wires from the rack dry thermostat.
3. Remove the 2 Phillips-head screws that attach the rack dry thermostat to the blower housing.

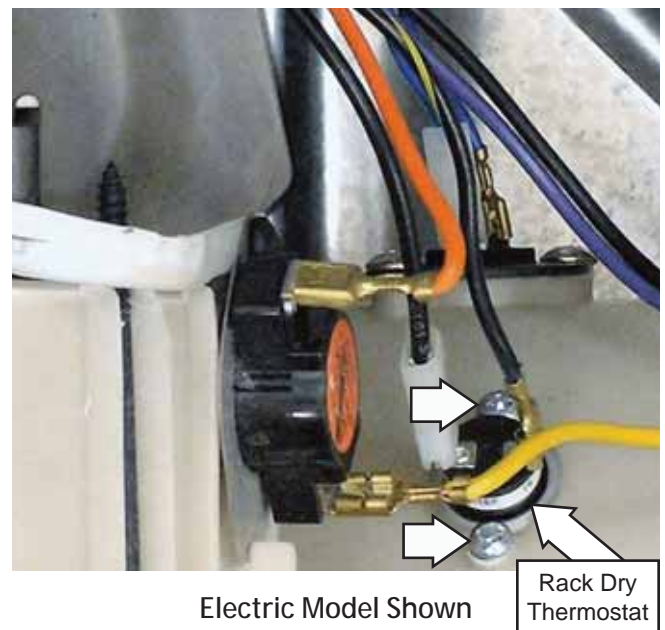

Electric Model Shown

Rack Dry  
Thermostat

## Power Board

The power board is mounted in a plastic housing that is attached to a bracket located under the top panel.

To remove the power board:

1. Remove the control and top panels. (See *Control Panel* and *Top Panel*.)
2. Mark and disconnect the wire harnesses and the ground wire from the dryer to the power board assembly.



3. Remove the 2 Phillips-head screws that attach the power board to the power board support.

**Note:** If replacing the power board, transfer the model selector harness to the replacement power board in the same location as on the original.



## Control Board Assembly

The control board assembly is mounted in a plastic housing that is attached to the inside of the control panel. It consists of 3 circuit boards connected by ribbons. The boards and the plastic housing are replaced as an assembly.

Operation of the control board assembly can be checked by using the service test mode. (See *Service Test Mode*.)

Error codes that are specific to the control board can initiate error codes E1 and E18. (See *Service Test Mode*.)

To remove the control board assembly:

**Caution:** To avoid marring the control panel, place the panel face down on a protective surface.

1. Remove the control and top panels. (See *Control Panel* and *Top Panel*.)
2. Remove the 5 Phillips-head screws that attach the control board plastic housing to the control panel. Remove the housing.

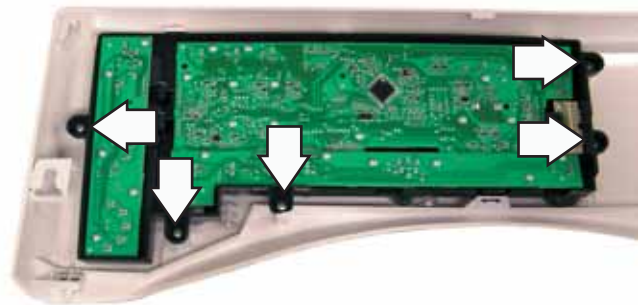

3. Remove the 26 Phillips-head screws that attach the control board assembly to the plastic housing.
4. Remove the wire harness from connection J1.

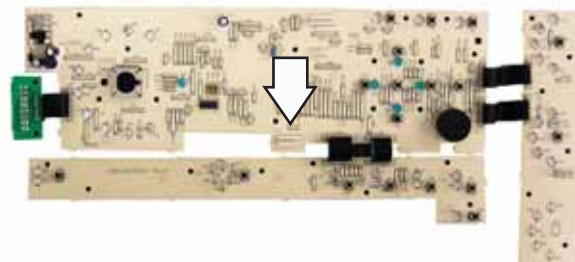

## Display Board

The display board is mounted on the underside of the plastic housing that holds the control board assembly. The display board snaps onto the plastic housing via 2 plastic tabs.

### To remove the display board:

**Caution:** To avoid marring the control panel, place the panel face down on a protective surface.

1. Remove the control and top panels. (See *Control Panel* and *Top Panel*.)
2. Remove the 5 Phillips-head screws that attach the control board plastic housing to the control panel. Remove the housing.

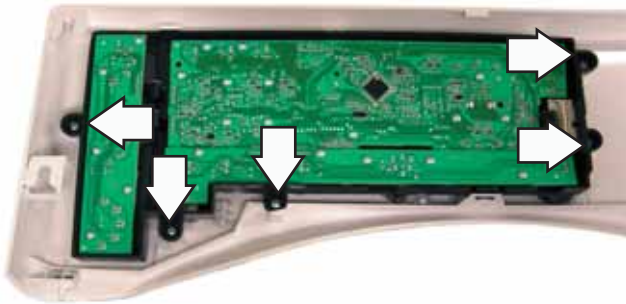

3. Turn the plastic housing over to expose the display board.



4. Remove the wire harness.
5. Release the display board from the 2 plastic tabs that attach the display board to the plastic housing.

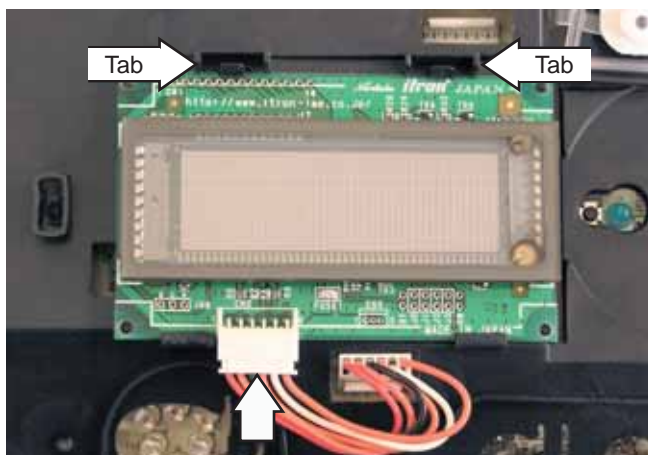

# Troubleshooting

## Service Test Mode

The dryer control has a service test mode that can be utilized by the service technician in order to test critical components and to access error codes. This test mode will help the service technician to quickly identify failed or improperly operating dryer components.

To enter the test mode:	To exit the test mode:
<p>With the power connected but the power button off:</p> <ol style="list-style-type: none"><li>1. Press the <i>MY CYCLE</i> button.</li><li>2. Press the <i>DELAY START</i> button.</li><li>3. Press the <i>MY CYCLE</i> button.</li><li>4. Press the <i>DELAY START</i> button.</li></ol> <p>Upon entering the service mode, the control shall be in test selection mode and display the list of tests on the vacuum fluorescent display (VFD). Scroll through the list of tests by using the up or down cursor arrows. Selection shall be represented by bold text.</p> <p>Once the desired test is highlighted, press <i>ENTER</i> to begin the test.</p> <p>During a test, press <i>POWER</i> to terminate it and go back to test selection mode.</p>	<p>Press the <i>POWER</i> button 3 times during the test selection mode.</p> <p><b>Note:</b> A dryer left in the test mode will exit the test mode after a period of 30 minutes.</p>



The following tables shows the diagnostic tests and the button sequence that is required to perform them:

Service Test Mode		Sequence	
t01	Configure UI	<i>ENTER</i>	Displays "configure UI"
		<i>POWER</i>	Returns to service mode screen
t02	Error Codes	<i>ENTER</i>	Displays error codes
		<i>START/PAUSE</i>	Clear highlighted error code from machine
		<i>POWER</i>	Returns to service mode screen
t03	Version Info	<i>ENTER</i>	Displays the current version of software
		<i>POWER</i>	Returns to service mode screen
t04	EEPROM Check	<i>ENTER</i>	Check EEPROM
		<i>POWER</i>	Returns to service mode screen
t05	UI Test	<i>ENTER</i>	LEDs light up
		<i>POWER</i>	Returns to service mode screen
t06	Key Continuity	<i>ENTER</i>	To begin testing
		<b>Any button but <i>POWER</i></b>	Hear beep as button is pressed
		<i>POWER</i>	Returns to service mode screen
t07	Outlet Thermistor	<i>ENTER</i>	Displays outlet thermistor temperature
		<i>START/PAUSE</i>	Drum tumbles and changes direction every 30 seconds
		<i>POWER</i>	Returns to service mode screen
t08	Inlet Thermistor	<i>ENTER</i>	Displays inlet thermistor temperature
		<i>START/PAUSE</i>	Drum tumbles and changes direction every 30 seconds
		<i>POWER</i>	Returns to service mode screen
t09	Moisture Sensor	<i>ENTER</i>	Displays moisture sensors reading
		<i>POWER</i>	Returns to service mode screen
t10	Blower/Exhaust*	<i>ENTER</i>	Blower turns on and UI displays rpm
		<i>POWER</i>	Returns to service mode screen
t11	Dryer Rack*	<i>ENTER</i>	Displays dryer rack temperature
		<i>POWER</i>	Returns to service mode screen

\* For the last two tests the blower fan is active.

Test Mode	Press	Displays	Exit
Configure UI	Enter	This test is currently not used.	Press <b>POWER</b> button to return to test mode menu.
Error Codes	Enter	<ul style="list-style-type: none"> <li>The control shall display the list of errors in the fault log upon entry into the error codes test. If more errors exist than can fit on the display, the technician can scroll through the list by using the up and down cursor arrows. If there are no errors in the fault log, <b>No Errors</b> shall be displayed on the VFD.</li> <li>The control shall clear the displayed error from the fault log if the <b>START/PAUSE</b> key is pressed while the error code is highlighted. After clearing the displayed error from the fault log, the next error in the fault log shall be highlighted with inverse text.</li> <li>After clearing all errors from the fault log, the control shall display <b>No Errors</b> on the VFD.</li> </ul>	Press <b>POWER</b> button to return to test mode menu.
Software Version	Enter	Displays the software version number and the non-volatile memory version number for both the user interface and main control boards.	Press <b>POWER</b> button to return to test mode menu.
Non-volatile memory	Enter	<ul style="list-style-type: none"> <li>The control shall compute the 16-bit CRC of the non-volatile memory for the user interface control and compare it with the pre-computed 16-bit CRC that is stored in the non-volatile memory.</li> <li>The control shall sound the Key Press beep and display <b>UI Memory Check OK</b> on the VFD after successful 16-bit comparison.</li> <li>The control shall display <b>UI Memory Error</b> on the VFD and sound the Invalid Key Press beep if the 16-bit CRC fails.</li> <li>Pressing the <b>Start/Pause</b> button shall initiate the CRC check for the power board. The control shall compute the 16-bit CRC of the non-volatile memory for the power board control and compare it with the pre-computed 16-bit CRC that is stored in the non-volatile memory.</li> <li>The control shall sound the key press beep and display <b>PB Memory Check OK</b> on the VFD after successful 16-bit CRC comparison.</li> <li>The control shall display <b>PB Memory Error</b> on the VFD and sound the invalid key press beep if the 16-bit CRC fails.</li> </ul>	Press <b>POWER</b> button to return to test mode menu.
User Interface	Enter	<p>The user interface control turns on all LEDs around the dial, the <b>POWER</b> and <b>START/PAUSE</b> button LEDs, and all segments on the VFD for a duration of 5 seconds.</p> <p>The control then turns on all remaining LEDs until the user exits this test.</p>	Press <b>POWER</b> button to return to test mode menu.

(Continued Next Page)

Test Mode	Press	Displays	Exit
Key Continuity	Enter	The control will sound the beep as long as a key is pressed.	Press <b>POWER</b> button to return to test mode menu.
Outlet Thermistor	Enter	<ul style="list-style-type: none"> <li>The control shall display the Outlet Thermistor temperature in degrees Fahrenheit on the VFD during the test.</li> <li>Pressing the <b>START/PAUSE</b> button shall turn on the drum motor and blower motor, and turn on the inner coil for electric dryer and the low flow gas valve for gas dryer.</li> <li>The control shall turn off the motor and inner coil heater/gas valve before exiting this test.</li> </ul>	Press <b>POWER</b> button to return to test mode menu.
Inlet Thermistor	Enter	<ul style="list-style-type: none"> <li>The control shall display the inlet thermistor temperature in degrees Fahrenheit on the VFD throughout the duration of the test.</li> <li>Pressing the <b>START/PAUSE</b> button shall start the drum motor and turn on the inner and outer coils for electric dryer and low flow and high flow gas valves for gas dryer.</li> <li>For every 30 seconds of run time, the control shall reverse the direction of the drum.</li> <li>Throughout the duration of the test, the VFD shall display the state of the centrifugal switch (as monitored by the micro input pin). It shall indicate whether the control thinks the switch is open or closed.</li> <li>The control shall turn off the drum motor and turn off the inner and outer coil heater/gas valve before exiting this test.</li> </ul>	Press <b>POWER</b> button to return to test mode menu.
Moisture Sensor	Enter	The control shall display the voltage read from the moisture sensor in volts on the VFD.	Press <b>POWER</b> button to return to test mode menu.
Blower/ Exhaust	Enter	<ul style="list-style-type: none"> <li>The control shall turn on the blower motor and display speed of the blower in RPM on the VFD.*</li> <li>Based on blower RPM, the control displays <b>Open Exhaust</b> (less than 2900 RPM), <b>Dirty Exhaust</b> (between 2900 and 3100 RPM), or <b>Blocked Exhaust</b> (greater than 3100 RPM), to indicate exhaust condition.</li> </ul>	Press <b>POWER</b> button to return to test mode menu.
Dryer Rack	Enter	Control enables the dryer rack cycle and displays the inlet thermistor temperature in degrees Fahrenheit on the VFD during the test.	Press <b>POWER</b> button to return to test mode menu.

\* The maximum dryer airflow is 150 CFM (cubic feet per minute). The service mode does not provide information about CFM. The only information that is provided is the condition of the exhaust system represented by blower motor RPM. Blower motor RPM will increase as the dryer exhaust system becomes partially restricted or restricted.

## Error Codes

Error Code	Component, System, or Test	Description and Corrective Action
E1	Interface EEPROM	Reading or writing improperly. Replace UI board.
E101	Power EEPROM	Reading or writing improperly. Replace power board.
E2	Inlet Short	Inlet thermistor shorted; check and replace if necessary.
E4	Inlet Open	Inlet thermistor open; check and replace if necessary.
E3	Outlet Short	Outlet thermistor shorted; check and replace if necessary.
E5	Outlet Open	Outlet thermistor open; check and replace if necessary.
E61	Check Electrical Connection	Input voltage too high; please check power connections.
E81	Power Model	No model select connector detected; check model selector on power board.
E10	Blower Motor	Blower motor is not rotating properly. Please check.
E11	Blocked Airflow	Check ventilation system.
E12	Drum Motor	Motor is not rotating properly or centrifugal switch is bad. Please check.
E16	LIN Comm Fail	There is a problem with the communication between the machine control and the UI control.
E17	VFD Communication Error	There is a problem with the serial communication interface between the UI and the VFD.
E18	Stuck Button	Stuck keys. Please check.

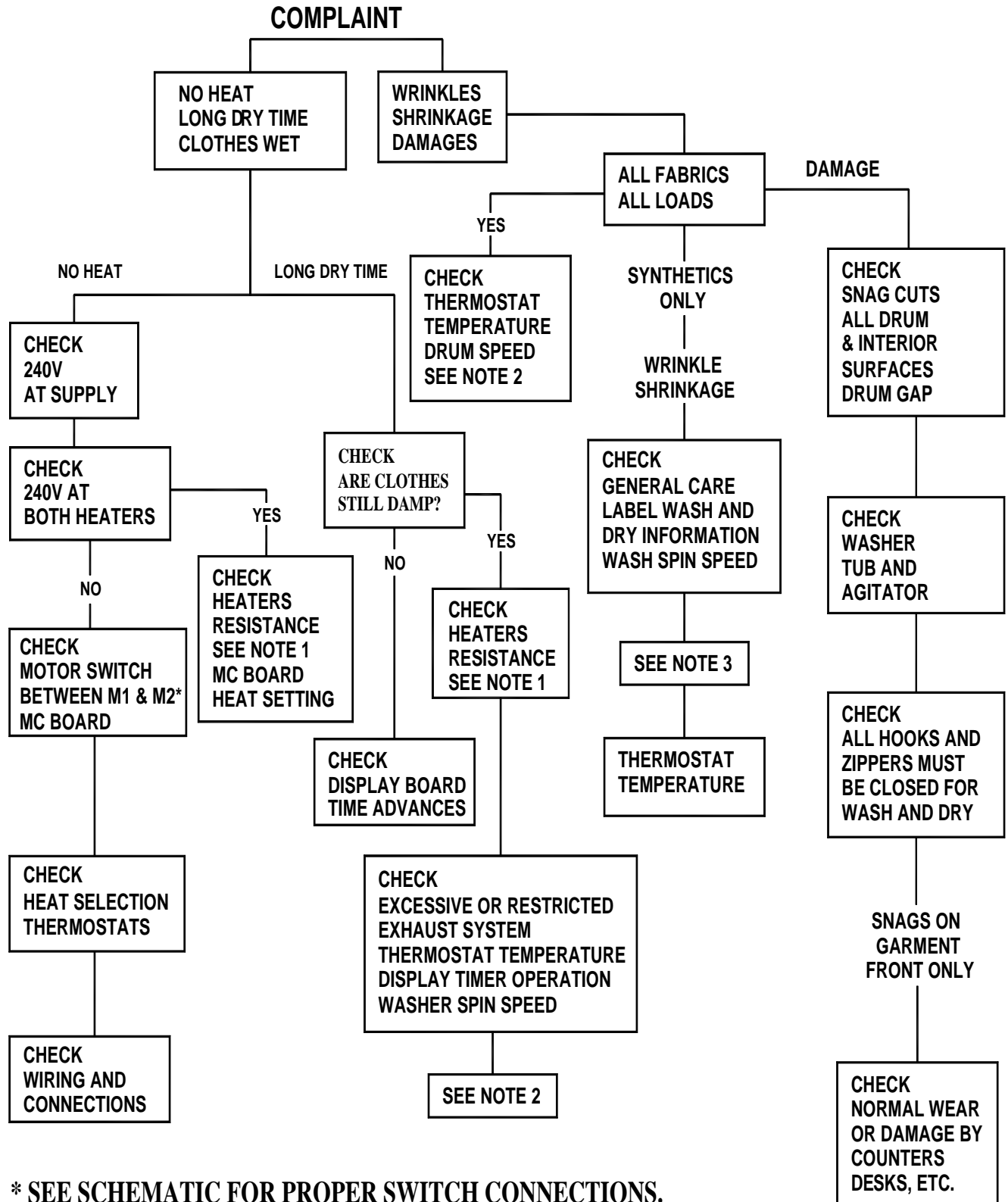

**COMPLAINT**

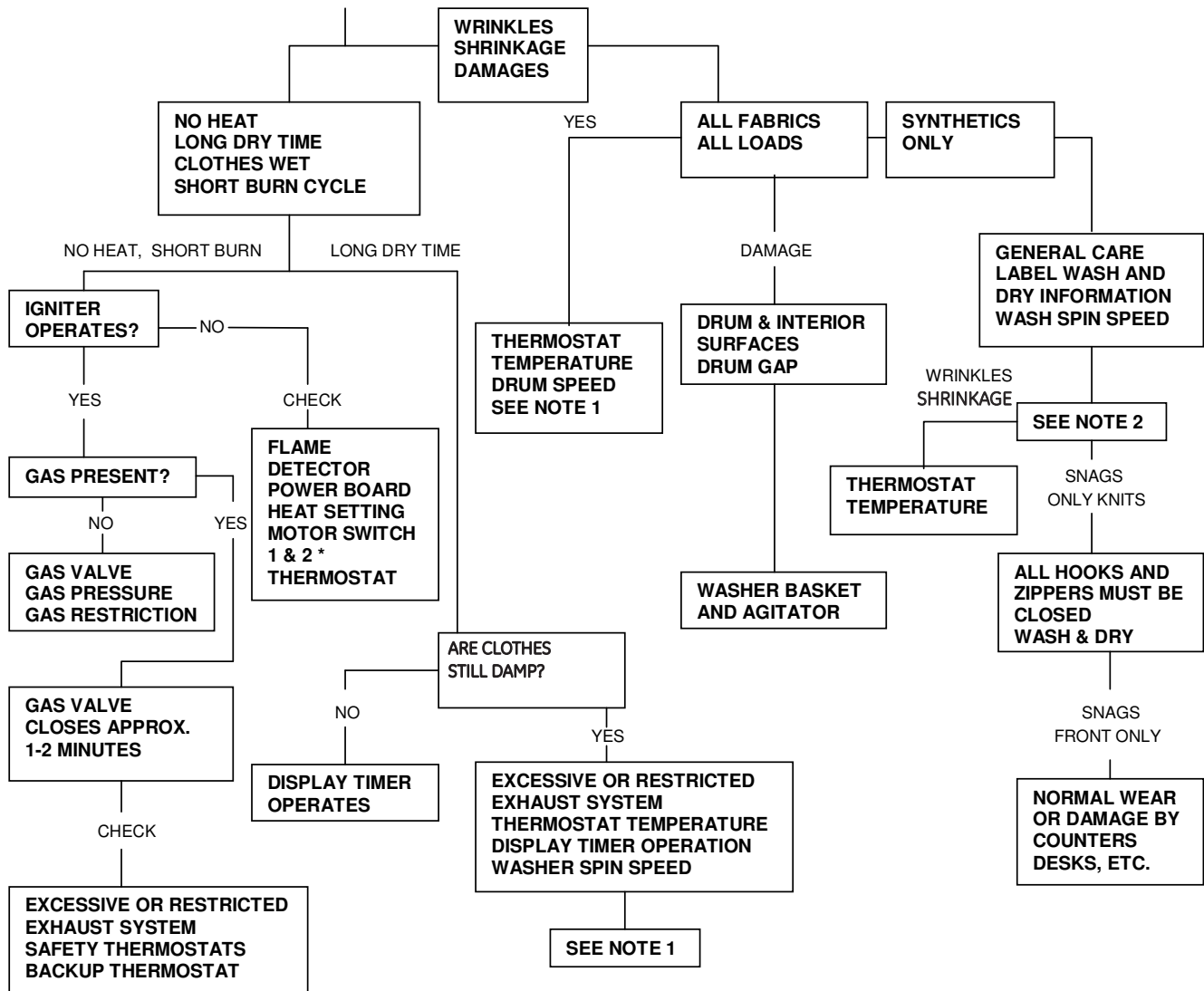

# Schematics and Wiring Diagrams

## Electric Model

**WARNING:** Disconnect electrical power before servicing.

**Caution:** Label all wires prior to disconnection. Wiring errors can cause improper and dangerous operation. Verify operation after servicing.

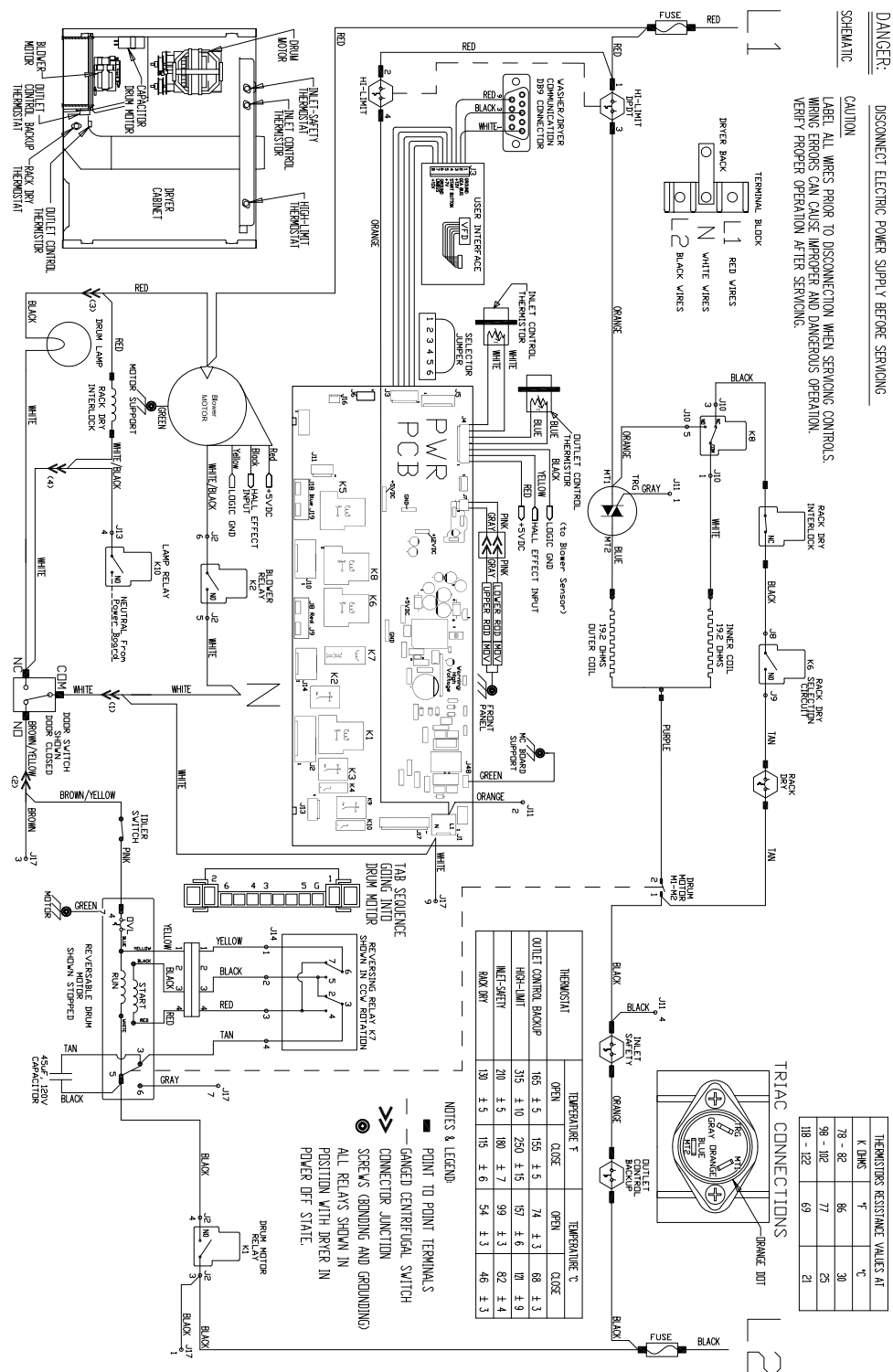

(Continued Next Page)

# Gas Model

**WARNING:** Disconnect electrical power before servicing.

**Caution:** Label all wires prior to disconnection. Wiring errors can cause improper and dangerous operation. Verify operation after servicing.

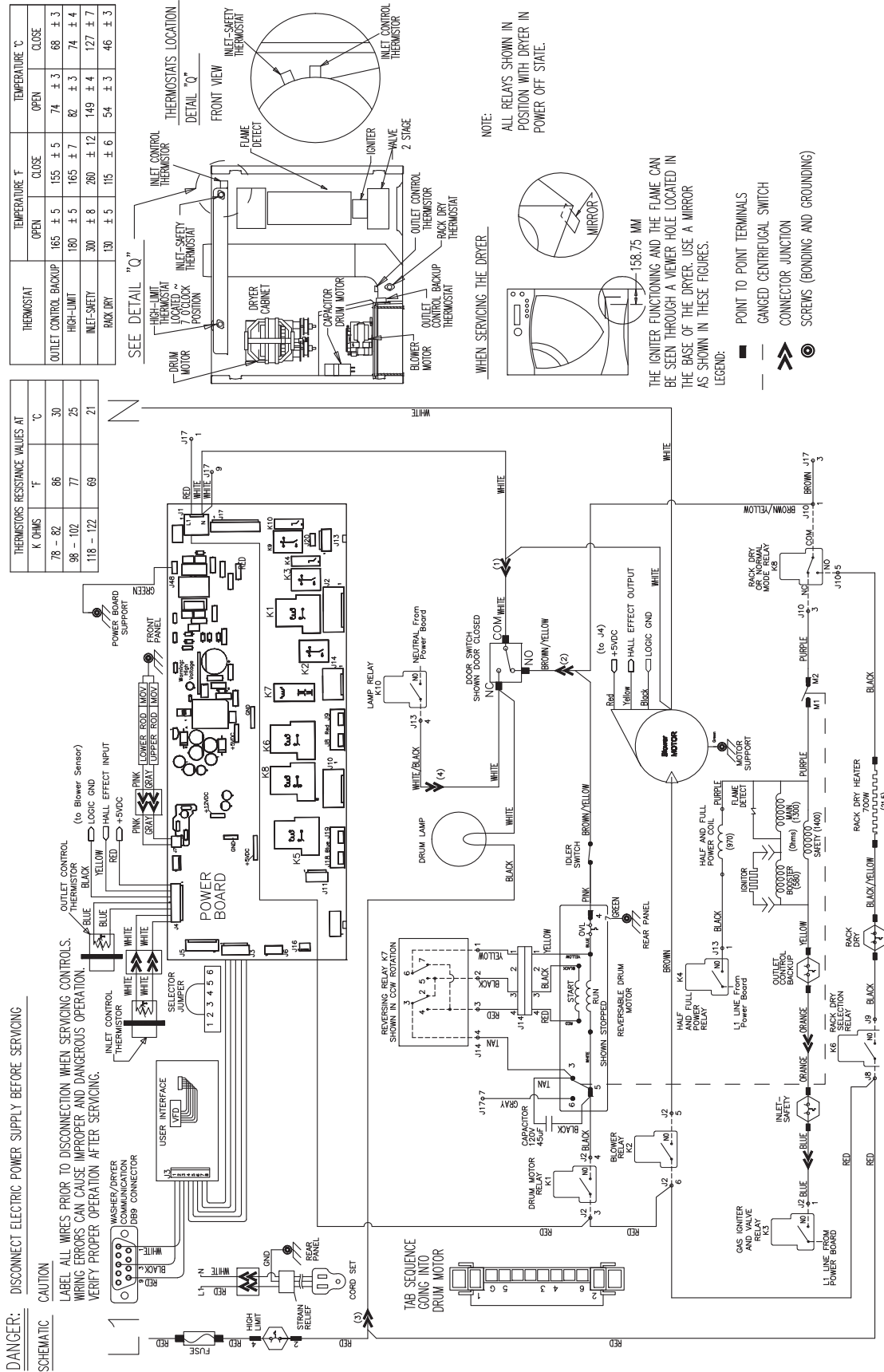



**WARNING:** Disconnect electrical power before servicing.

**Caution:** Label all wires prior to disconnection. Wiring errors can cause improper and dangerous operation. Verify operation after servicing.

### Rack Dry Circuit - Electric Models

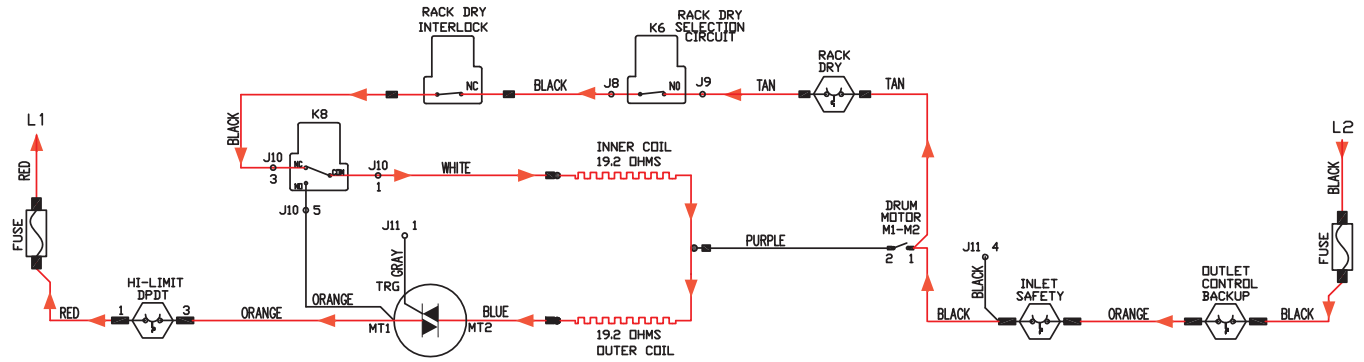

### Rack Dry Circuit - Gas Models

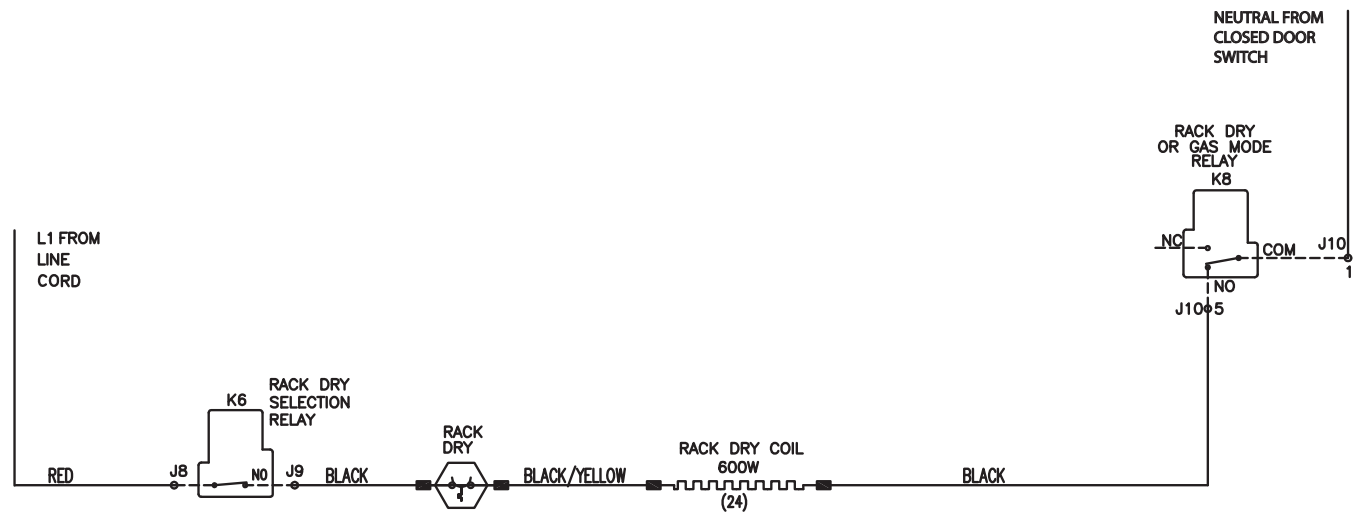

## Drum Motor Circuit - Electric Models

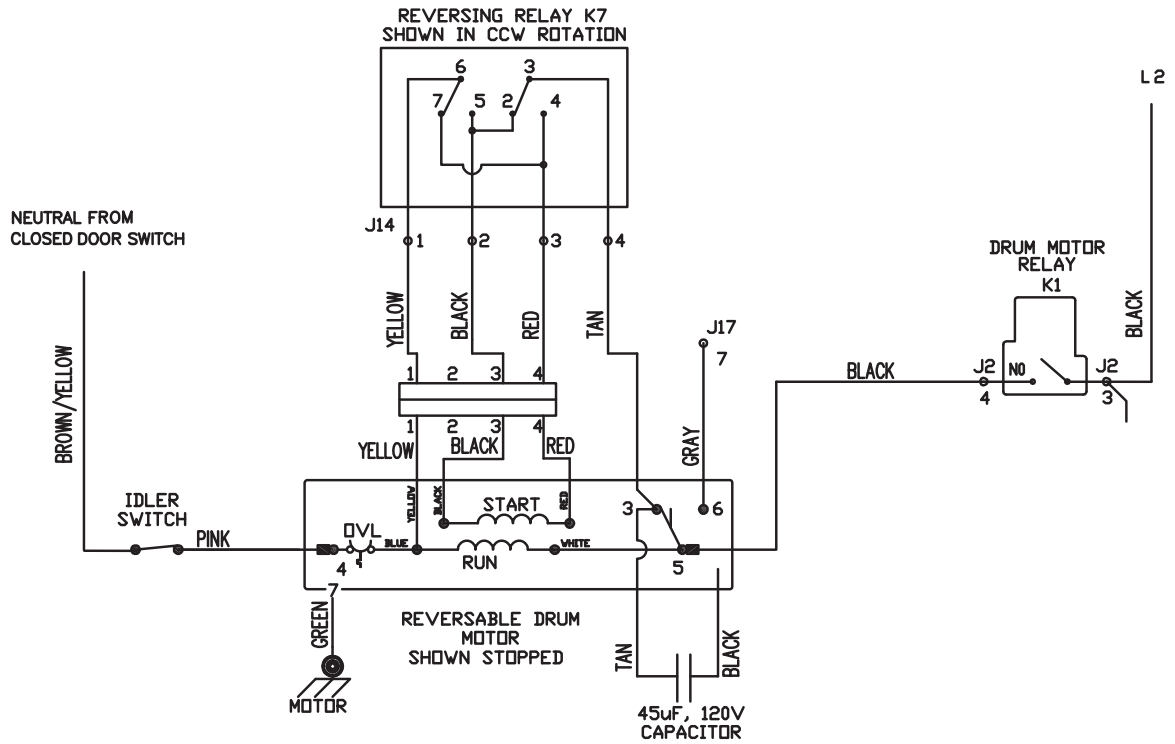

## Drum Motor Circuit - Gas Models

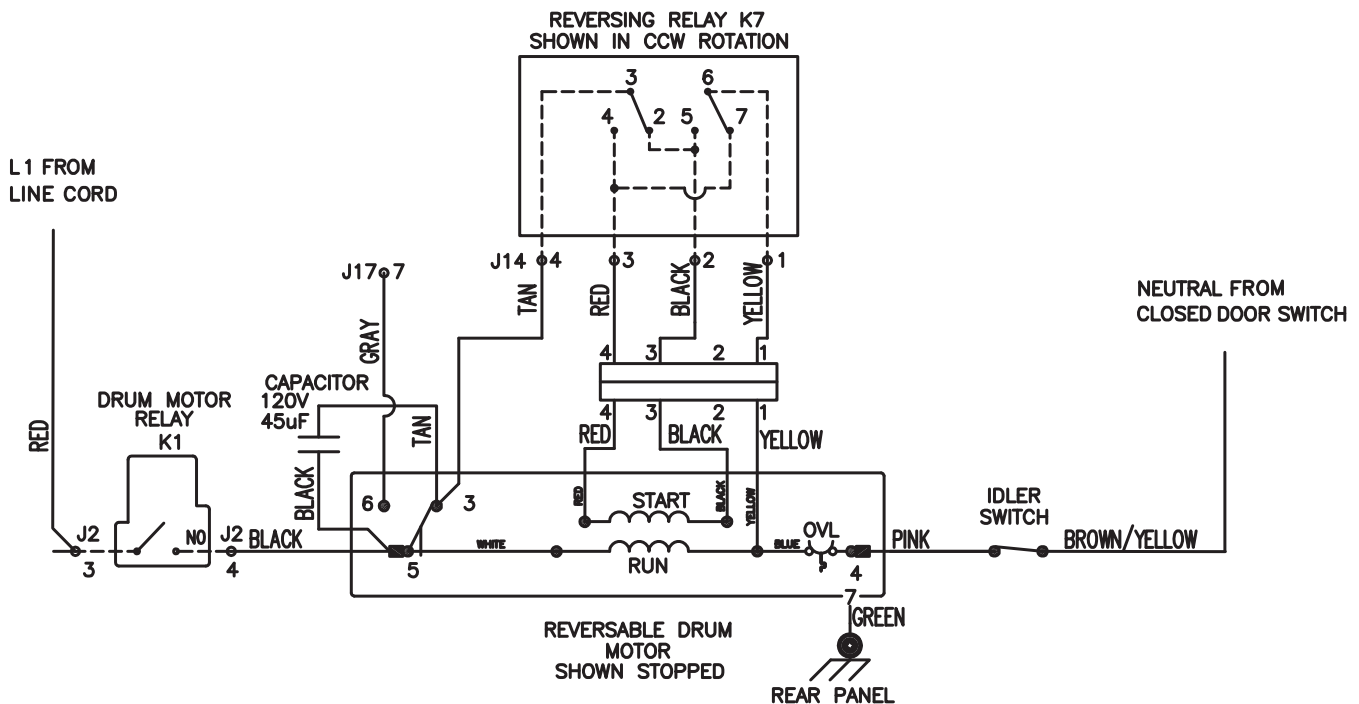

## Blower Motor Circuit - Electric Models

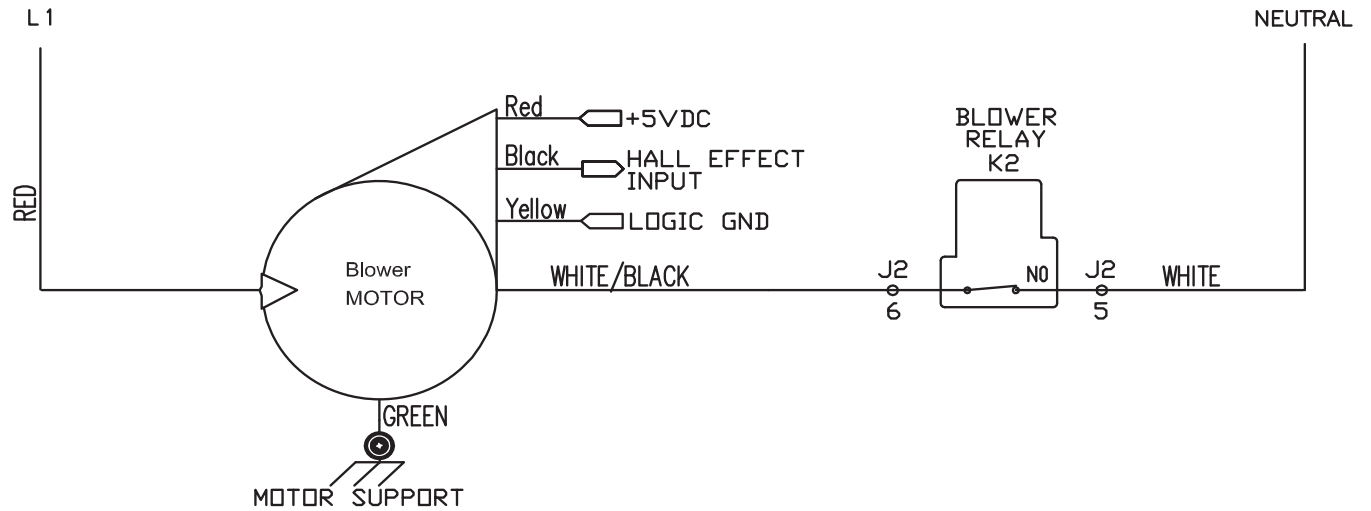

## Blower Motor Circuit - Gas Models

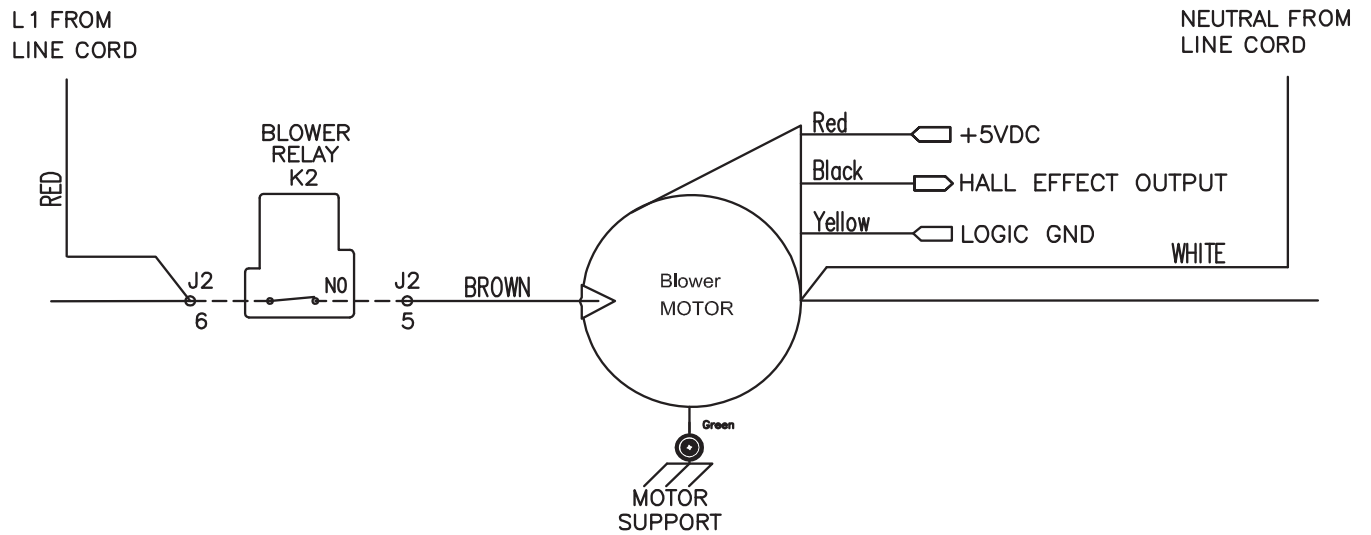

## Gas Valve Circuit

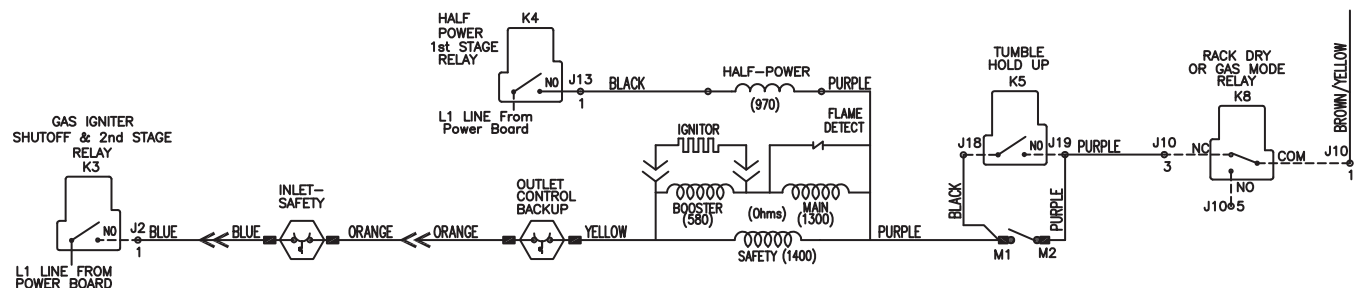

# Warranty

## GE Dryer Warranty. *(For customers in the United States)*



All warranty service provided by our Factory Service Centers, or an authorized Customer Care® technician. To schedule service, on-line, visit us at [ge.com](http://ge.com), or call 800.GE.CARES (800.432.2737).

Please have serial number and model number available when calling for service.

Staple your receipt here.  
Proof of the original purchase date is needed to obtain service under the warranty.

For The Period Of:	We Will Replace:
<b>One Year</b> <i>From the date of the original purchase</i>	<b>Any part</b> of the dryer which fails due to a defect in materials or workmanship. During this <b>limited one-year warranty</b> , GE will also provide, <b>free of charge</b> , all labor and related service costs to replace the defective part.
<b>Second Year</b> <i>From the date of the original purchase</i>	<b>Any part</b> of the dryer which fails due to a defect in materials or workmanship. During this <b>additional one-year limited warranty</b> , you will be responsible for any labor or related service costs.
<b>Second through Fifth Year</b> <i>From the date of the original purchase</i>	<b>The extra-large or super-capacity dryer drum and main electronic control board</b> if any of these parts should fail due to a defect in materials or workmanship. During this <b>additional three-year limited warranty</b> , you will be responsible for any labor or related service costs.

### What Is Not Covered (in the United States):

- Service trips to your home to teach you how to use the product.
- Improper installation, delivery or maintenance.
- Failure of the product if it is abused, misused or used for other than the intended purpose or used commercially.
- Replacement of the light bulb after its expected useful life.
- Replacement of house fuses or resetting of circuit breakers.
- Damage to the product caused by accident, fire, floods or acts of God.
- Incidental or consequential damage caused by possible defects with this appliance.
- Damage caused after delivery.
- Product not accessible to provide required service.

**EXCLUSION OF IMPLIED WARRANTIES—Your sole and exclusive remedy is product repair as provided in this Limited Warranty. Any implied warranties, including the implied warranties of merchantability or fitness for a particular purpose, are limited to one year or the shortest period allowed by law.**

This warranty is extended to the original purchaser and any succeeding owner for products purchased for home use within the USA. If the product is located in an area where service by a GE Authorized Servicer is not available, you may be responsible for a trip charge or you may be required to bring the product to an Authorized GE Service location for service. In Alaska, the warranty excludes the cost of shipping or service calls to your home.

Some states do not allow the exclusion or limitation of incidental or consequential damages. This warranty gives you specific legal rights, and you may also have other rights which vary from state to state. To know what your legal rights are, consult your local or state consumer affairs office or your state's Attorney General.

**Warrantor: General Electric Company, Louisville, KY 40225**