



*GE Appliances*

---

**Service  
Handbook**

**Automatic Washer  
and Dryer**

**1978 & Later**

## **IMPORTANT SAFETY NOTICE**

Major appliances are complex electromechanical devices. General Electric Company's Major Appliance Service Publications are intended for use by individuals possessing adequate backgrounds of electrical, electronic and mechanical experience. Any attempt to repair a major appliance may result in personal injury and property damage. General Electric Company cannot be responsible for the interpretation of its service publications, nor can it assume any liability in connection with their use.

## **SAFE SERVICING PRACTICES**

To preclude the possibility of resultant personal injury \* and/or property damage, \*\* it is important that safe servicing practices be observed. The following are examples, but without limitation, of such safe practices.

1. Before servicing, always disconnect the product from its electrical power source by removing the product's electrical plug from the wall receptacle, or by removing the fuse (or tripping the circuit breaker to OFF) in the branch circuit serving the product.

NOTE: If a specific diagnostic check requires electrical power be applied (e.g., a voltage or amperage measurement, etc.), reconnect electrical power only for the time required for such a check, and disconnect it immediately thereafter. During any such check, ensure no other conductive parts (panels, etc.) - or yourself - come in contact with any exposed current-carrying metal parts.

2. Never interfere with or bypass the proper operation of any feature, part or device engineered into the product.
3. If a replacement part is required, use the specified General Electric Company part, or an equivalent which will provide comparable performance.
4. Prior to reconnecting the electrical power source to the washer or dryer, be sure that:
  - a) all electrical connections within the product are correctly and securely connected,
  - b) all electrical harness leads are properly dressed and secured away from sharp edges, high-temperature components (e.g. resistors, heaters, etc.) and moving parts,
  - c) any uninsulated current-carrying metal parts are secure and adequately spaced from all non-current-carrying metal parts,

- d) all electrical grounds - both internal and external to the product are correctly and securely connected.
  - e) all water connections are properly tightened on washers.
  - f) all panels and covers are properly and securely reassembled.
5. Read the SAFETY PRACTICES section beginning on page G-1 in this Book for additional SAFE SERVICING PRACTICES.
6. Don't attempt a product repair if you have any doubts as to your ability to complete it in a safe and satisfactory manner.

\*PERSONAL INJURY, in the form of electrical shock, burns, cuts or abrasions, etc. can occur spontaneously to the individual while attempting to repair or service the product, or may occur at a later time to any individual in the household who may come in contact with the product - unless safe servicing practices are observed.

\*\*PROPERTY DAMAGE, resulting from fire, flood, etc., can occur immediately or at a later time as a result of attempting to repair or service the product - unless safe servicing practices are observed.

## **PREFACE**

This HANDBOOK contains information and service procedures to assist the Service Technician in correcting conditions that are not always obvious. Service procedures considered to be obvious are intentionally omitted.

Using the information in this HANDBOOK in conjunction with the Mini-Manuals which are included with most 1978 & later General Electric and Hotpoint Washer and Dryers will provide a comprehensive familiarity with these models.

All electrical data, schematics, cam charts, and switch functions are in the Mini-Manuals with the product. Refer to BACKSPLASH.

**WASHER PAGE E2**

**DRYER PAGE T2**

For location and information on access to the Mini-Manual.



# **AUTOMATIC WASHER TABLE OF CONTENTS**

<b>GENERAL</b>	<b>A</b>
<b>TIMERS &amp; CIRCUITS</b>	<b>B</b>
<b>WATER SYSTEMS</b>	<b>C</b>
<b>DRIVE SYSTEM</b>	<b>D</b>
<b>CABINET CONSTRUCTION &amp; SUSPENSION SYSTEM</b>	<b>E</b>
<b>OTHER COMPONENTS</b>	<b>F</b>
<b>SAFE INSTALLATION &amp; SERVICE PRACTICES</b>	<b>G</b>
<b>USE &amp; CARE, WASHABILITY</b>	<b>H</b>
<b>DIAGNOSIS</b>	<b>I</b>
<b>FIELD CORRECTIONS</b>	<b>J</b>
<b>PORTABLE AUTOMATIC WASHER</b>	<b>K</b>

This HANDBOOK covers both General Electric and Hotpoint Automatic Washers produced from 1978 thru 1986. All pertinent service information after August 1986 will be issued via SERVICE BULLETINS and will be released in the next issue of the HANDBOOK.

The GENERAL ELECTRIC Model numbers have the first suffix letter (model series) of P, V, or B. See page A3 for complete model number description. The serial number prefix letters are also described on page A3.

The HOTPOINT model numbers have the first suffix letter (model series) of P, T, W, A, or B. See page A3 for complete model number description. The serial number prefix letters are also described on page A3.

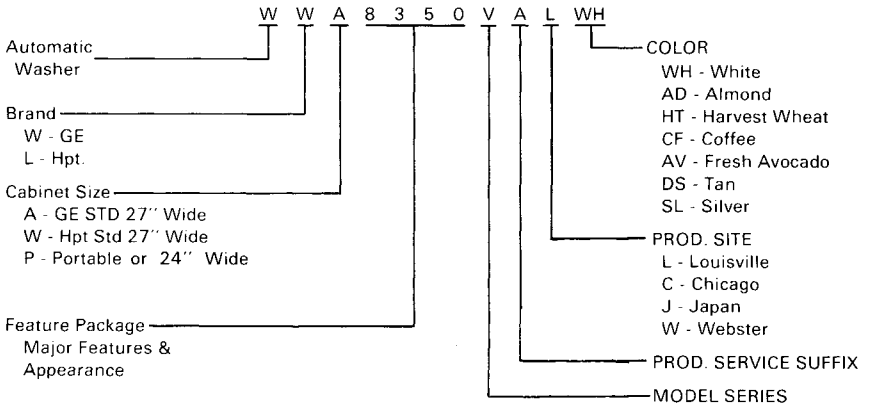
AUTOMATIC WASHERS - as they leave the factory, Automatic Washers are made to operate on 120V/160 Hz., 120V/50 Hz., or 220V/50 Hz., as indicated on the rating plate. To convert from one voltage and frequency (Hz) to another requires several parts changes. Refer to section on Conversions for list of parts, Section G.

CAPACITY - Automatic Washers are made in three different capacities -COMPACT, \*STANDARD, and \*LARGE. This description is used throughout this HANDBOOK.

\*Revised on "G" model General Electric brand to LARGE & EXTRA LARGE capacity.

**AUTOMATIC WASHER  
NAMEPLATE DATA**

MODEL NUMBER



**Serial Number Prefix Codes**

<u>1st Letter</u>	<u>2nd Letter</u>	<u>MONTH</u>	<u>YEAR</u>
JAN	A	1973	P
FEB	D	1974	T
MAR	F	1975	V
APR	G	1976	Z
MAY	H	1977	A
JUN	L	1978	D
JUL	M	1979	F
AUG	R	1980	G
SEP	S	1981	H
OCT	T	1982	L
NOV	V	1983	M
DEC	Z	1984	R
		1985	S
		1986	T
		1987	V
		1988	Z

Example:

AM123456G =  
Model Built in January 1983

Serial Number Prefix Codes





**INDEX**

	<b>PAGE</b>
Timer - Clam Shell	B - 2
Timer - Singer	B - 11
Timer - Spotscribber	B - 21

# TIMERS & CIRCUITS

## TIMER — CLAM SHELL

### Test Of Timer

1. Visually check the Cam Followers to see that they are all in place and move freely. Turn the face cam by hand to see that it is not binding.
2. Connect 120 volts to timer motor. Check that output gear turns, control not binding. Disconnect power.
3. The leaf switch contacts should be checked for signs of arcing or welding together. If any contacts are damaged, replace the individual switch.
4. To check the operation of the timer switches, check each switch separately as follows:
  - a. Set timer to Off position.

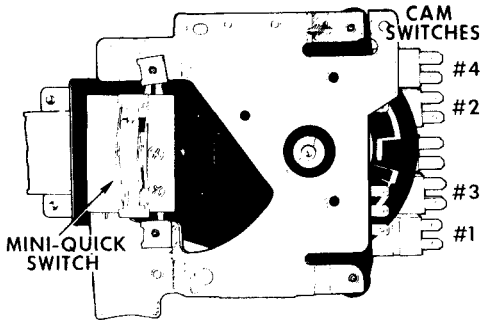
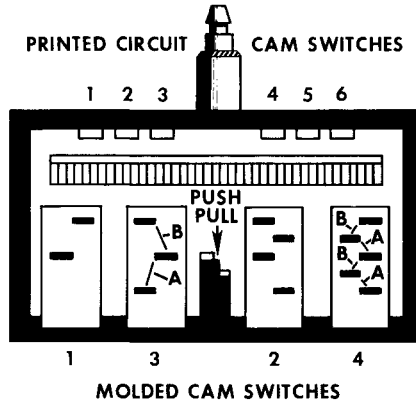


Figure 1 — Timer - Front View

- b. Disconnect all leads from switch to be checked.
- c. Connect a continuity tester (Ohmmeter or test lamp) across the pair of contacts to be checked and rotate the timer dial through the cycle or through the period where trouble is suspected.



**Figure 2 — Timer Terminal Identification**

NOTE: The letters shown between the switch leaves of molded cam switches No. 3 and No. 4 identify closed contacts which correspond to the modes of operation, as shown on both the cam charts and schematics. The No. 2 switch modes are not identified because of the several different functions performed by the No. 2 switch. Also, No. 2 switch is not used on every timer.

- d. Observe the indications of the continuity tester and compare with the cam chart for that pair of switch contacts.
- e. Connect continuity tester to other pair of contacts and repeat steps b, c and d above.

### Molded Cam Switch Replacement

Molded cam switches No. 1 and No. 3 can be replaced without completely disassembling timer. Hold timer with shaft down. Remove switch mounting screw and remove switch. Take care not to disturb cam followers. It will help if face cam is rotated so that cam followers are not compressing switch leaves. Reverse procedure for reassembly, No. 2 and No. 4 switches are more complex and cannot be easily removed without complete disassembly of timer.

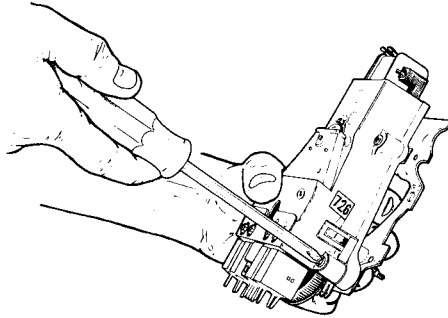
### Timer Disassembly

On Mini-Quick Timers (G.E.) remove the two Phillips screws holding the Mini-Quick switch. Remove the spring clip off the "D" shaft.

On Rapid Wash Timers (Hotpoint) pull the spring clip off the "D" shaped ratchet shaft.

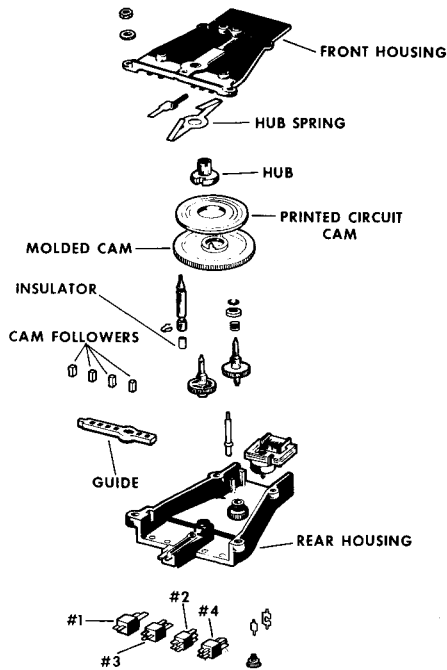
# TIMERS & CIRCUITS

Hold the timer tightly, as shown in Figure 3, so that the front housing is held against the force of the hub spring. Remove the four Phillips screws.



**Figure 3 — Timer Disassembly**

Set timer down on its back and slowly release thumb pressure. Lift off front housing. Now all parts except molded cam switches can be removed without use of tools, Figure 4.



**Figure 4 — Clam Shell Timer - Exploded View**

Cam Follower Location

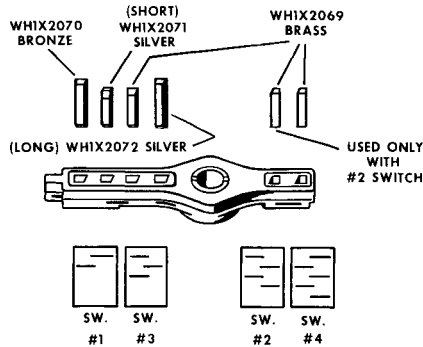


Figure 5 — Cam Followers and Switches

The short brass cam followers (WH1X2069) actuate switch No. 2, 4 and the 3-B mode of switch No. 3. The short silver cam follower (WH1X2071) and the long bronze cam follower (WH1X2070) actuate switch No. 1. The long silver cam follower (WH1X2072) actuates the 3-A mode of switch No. 3, see Figure 5.

For the WH1X2069 and WH1X2070 cam followers, the end that bears against the cam face is the flatter end. For the WH1X2071 and WH1X2072, the end that bears against the cam face is the more pointed end, Figure 6. NOTE: WH1X2070 is the same shape as WH1X2069, except it is longer. WH1X2072 is the same shape as WH1X2071, except it is longer.

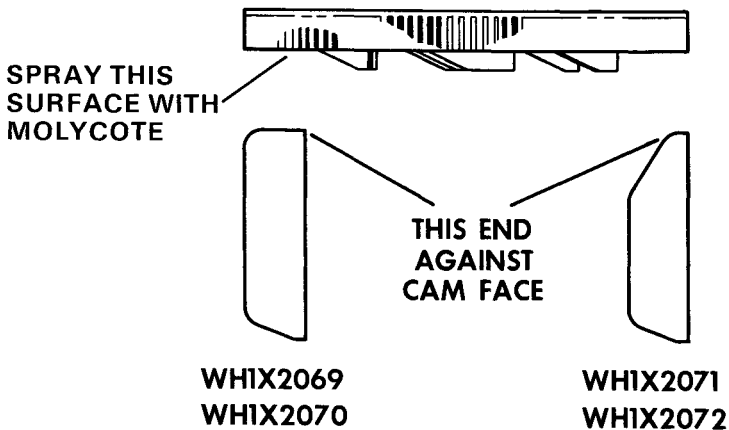
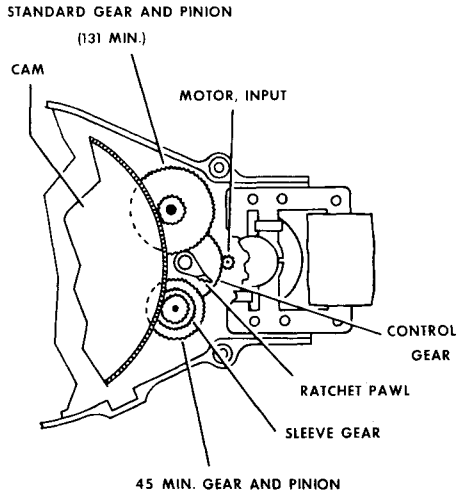


Figure 6 — Cam Followers

**Timer Reassembly**

Figure 7 shows correct position of gears and ratchet pawl in "Mini-Quick" and Rapid Wash Timers.



**Figure 7**

Use care when reinstalling front housing to insure that gear shafts are aligned with bearing holes. **DO NOT FORCE FRONT HOUSING ON.**

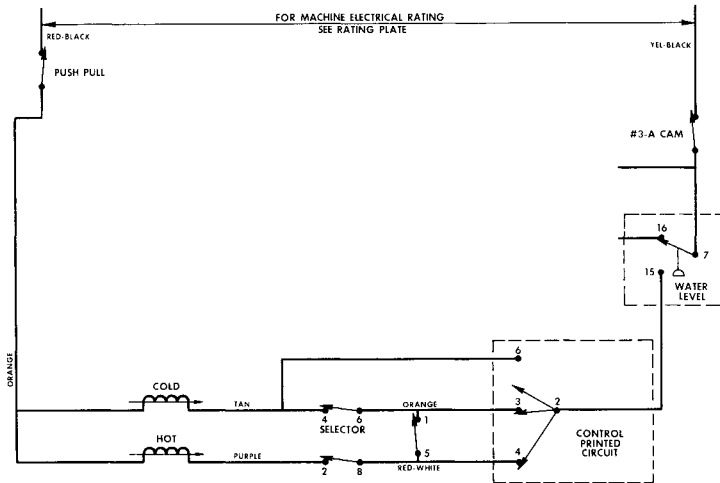
The printed circuit cam sits in a recess in the back of the face cam. It may be replaced without replacing the face cam, and it is keyed so that it will fit the face cam recess in only one position.

On Mini-Quick timers, the "V" notch on the bottom of the rocker button must embrace the end of the spring clip before tightening the two mounting screws.

For operation of Mini-Quick timer, see Section F.

## BASIC CIRCUITS — CLAM SHELL (GE)

### Fresh Water Fill



WASH/RINSE	TEMP. SELECT		
	1-5	2-8	4-6
COLD/COLD			■
WARM/COLD		■	■
HOT/COLD		■	■
WARM/WARM	■	■	■
HOT/WARM	■	■	■

CYCLE	P.C. CONTACTS		
	2-3	2-4	2-6
WASH FILL	■	■	■
RINSE FILL	■	■	■
SPRAY RINSE			■

The partial schematic shows that water LEVEL is controlled by the water level switch (WLS). The TIME when water enters the washer is determined by the control printed circuit cam switches. The TEMPERATURE is regulated by the temperature selector switches (in most cases).

It can be seen that the WLS must be in its reset mode (7-15 closed) before any water can enter the washer. All other circuits such as the timer motor, drive motor, speed solenoid, etc. are isolated during wash and rinse fill. During spray rinse the other circuits are activated by the B mode of the #3 cam switch (not shown).

Many models will not have the 1-5 selector switch contacts. They will not have any warm rinse fill or spray rinse. They will be strictly cold. Some models will not have any temperature selector switch. Water temperature is regulated by adjusting faucets. This means that separate adjustments may be necessary for wash and for rinse.

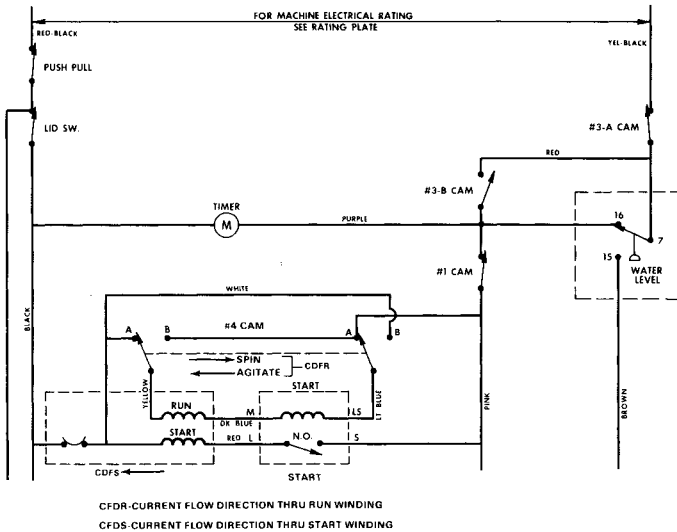
For specific details for a given model refer to the Mini-Manual in the Backsplash.



# TIMERS & CIRCUITS

## BASIC CIRCUITS

### Timer & Drive Motors



FUNCTION	TIMER CAM SWITCHES			
	1	3A	3B	4B
AGITATE				
SPIN				

The partial schematic shows that the timer motor and the drive motor are in parallel circuits. They are both energized thru the water level switch (WLS) or the B mode of the #3 cam switch. The #1 cam switch is the drive motor On-Off switch. It stops and starts the drive motor between the agitate and spin functions. The A and B modes of the #4 cam switch provide the drive motor reversing function.

### DRIVE MOTOR

The main winding and the start winding in the drive motor are in parallel circuits. The coil in the start relay is in series with the main motor winding. Before current is applied, the relay switch, which is in series with the start winding, is open. When current is first applied the run winding is stalled and draws a high current. That same high current is also present at the relay coil which creates a strong magnetic field within the relay. This magnetic field closes the relay switch and completes the circuit to the start winding. The start winding gives a kick to the motor rotor which causes it to start turning. The current in the run winding now drops, removing the magnetic field, and the relay switch opens. The motor continues to turn on the run winding only. The start winding has its current removed in only a few seconds because its thin wires cannot withstand much current for any long period of time.

## AGITATION

The washer will not start to agitate until the WLS has been tripped — contacts 7-16 closed. For agitation both parts of the #4 switch are closed in the A mode. In this condition it can be said that, at any given instant, the current in the run and start windings is flowing in the same direction. This would start the rotor turning in the clockwise direction — as viewed from the shaft end.

## SPIN

The B mode of the #3 switch closes just before the end of the agitation cycle to insure power to the drive motor when the water has been pumped out and the WLS resets (7-15).

For spin both parts of the #4 switch are closed in the B mode. In this condition it can be said that, at any given instant, the current in the run and start windings is flowing in opposite directions. This would start the rotor turning in the counterclockwise direction.

## #1 & #4 SWITCHES

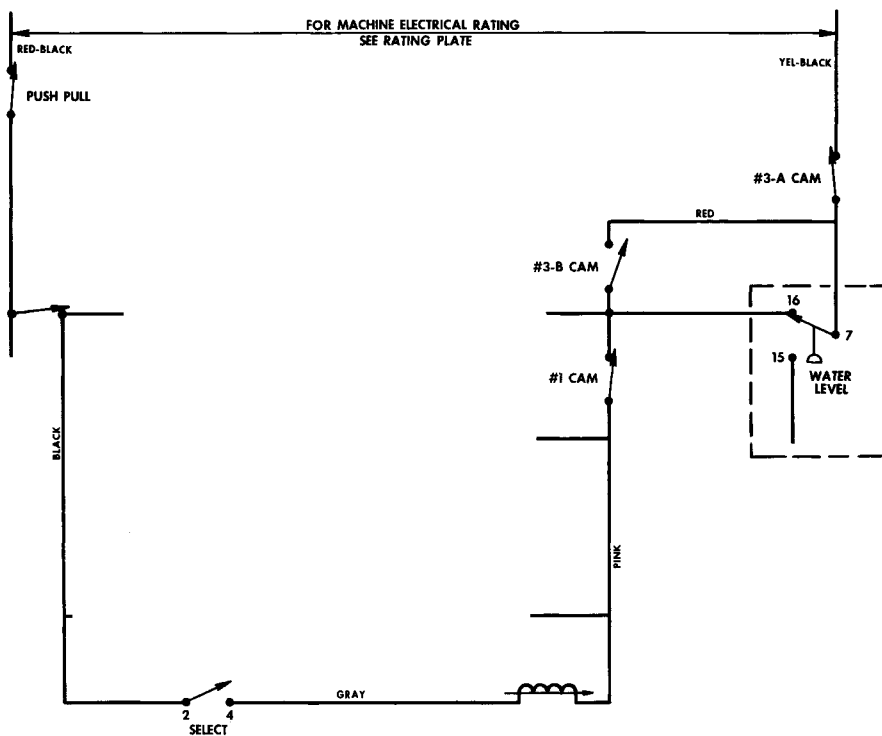
The #4 switch changes modes only during those times when the #1 Switch is open. This is necessary because the #4 switch uses a slow make and break of its contacts. If current were flowing thru the switch during the slow make and break process arcing and burning of the contacts would occur.

# TIMERS & CIRCUITS

## BASIC CIRCUITS

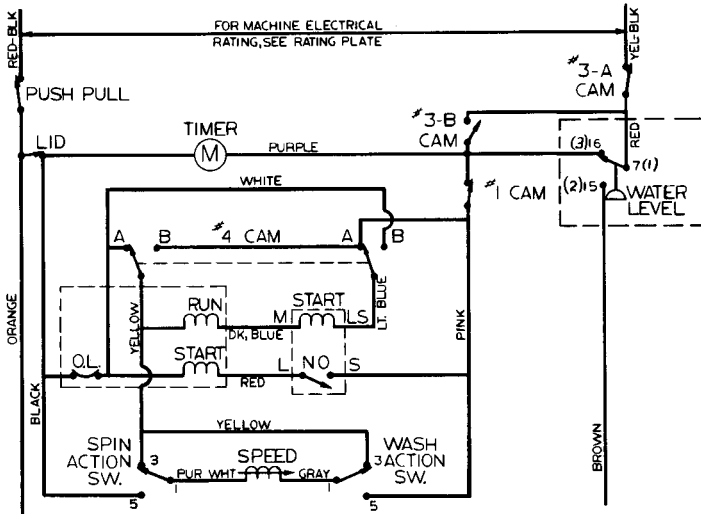
### Speed Shifters

Two agitation and spin speeds are provided by a two speed clutch and a speed shifter. The motor speed is constant. The clutch and shifter are the same for all 2-speed models.



ACTION SW.	
WASH	TERMS.
SPIN	2-4
NORMAL	
FAST	
GENTLE	
SLOW	

Speed shifter circuits come in several different forms. The simplest circuit is with the selector switch and shifter solenoid in series. These are in parallel with the drive motor. When selector switch contacts 2-4 are closed the washer provides gentle agitation and slow spin. This is called "locked speeds".



SPIN SPEED SW.	
SPEED	TERMS
	1-3   1-5
FAST	<input checked="" type="checkbox"/>   <input checked="" type="checkbox"/>
SLOW	<input type="checkbox"/>   <input checked="" type="checkbox"/>

WASH SPEED SW.	
SPEED	TERMS
	1-3   1-5
NORMAL	<input checked="" type="checkbox"/>   <input checked="" type="checkbox"/>
GENTLE	<input type="checkbox"/>   <input checked="" type="checkbox"/>

A more complicated circuit, as shown in the partial schematic, provides four combinations of agitation and spin speeds. These are controlled by the two speed selector switch settings and the mode of the #4 cam switch. That is, the wash speed selector switch setting is effective only when the #4 switch is in the A mode. The spin speed selector switch setting is effective only when the #4 switch is in the B mode.

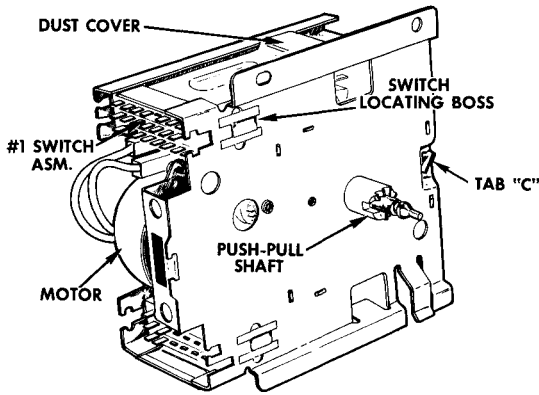
Some models will have three combinations controlled by one switch. For specific details for a given model refer to the Mini-Manual in the backspash.

## TIMER — SINGER

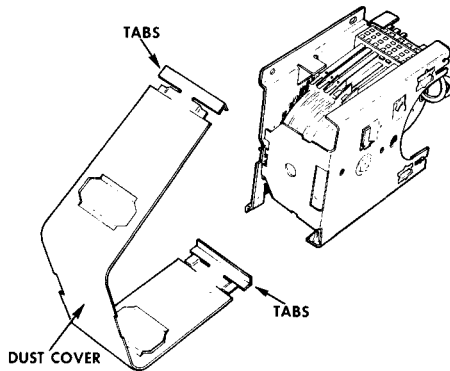
To remove timer from washer:

1. Open backspash (refer Section E).
2. Remove 2 screws.
3. Remove harness terminal block from switch bank.
4. Remove pin from behind knob.
5. Pull off knob and dial pointer disc.

# TIMERS & CIRCUITS



**Figure 8 — Front View**



**Figure 9 — Dust Cover Removed**

Figure 9 shows the dust cover removed and exposes the switch leaves and 1 piece cam. Before removing, however, note position of all tabs and offsets on the dust cover.

Most timers will have only 1 Switch Asm. - #1.

## **PARTS**

The timer motor controls the cam speed. It is the variations in timer motor speeds that allows us to have cams which will give us one or several cycles during one 360° revolution. Therefore, it is essential that timer motors be identified by model from the catalog pages. The replacement switch banks are more standardized and they will have the maximum number of leaves. All the leaves may not be needed or used on all models but they will not affect timer operation.

The timer motor and the switch assemblies can be replaced individually if they should fail. (Figure 10).

To replace the timer motor remove the 2 Phillips screws and the 2 single connector blocks. Reconnect the blocks on the new motor and reassemble motor with 2 Phillips screws.

To replace a Switch Asm. remove the dust cover, Figure 9. Straighten one of the tabs — "A" for #1 Switch Asm. or "B" for #2 Switch Asm. (Figure 10). Spread the 2 plates so that the switch locating bosses (Fig. 8) are free. Carefully remove the switch. Install the replacement switch asm. and squeeze the plates together. Make sure that the switch locating bosses are firmly seated in the appropriate cutouts in both plates. Bend the Tab ("A" or "B") to its original position.

Figure 12 shows the correct position of the switch leaves relative to the cam. If the leaves are cocked and not riding squarely in the cam tracks, lift the ends of the leaves with your finger tips and let them fall back into the correct position. The tip of the push-pull switch slider must be inside the plastic inverted U leaf guide.

To replace any other parts follow the instructions below:

## **Disassembly**

Straighten tabs A & B (Fig. 10) and Tab C (Fig. 9). Pull the plates apart and all the internal parts will be accessible.

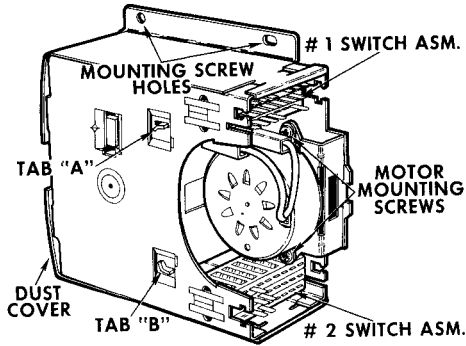
## **Reassembly**

- a. Slide the shaft thru the cam. Be sure that the detent pin is in place. Slip the hub of the cam thru the hole in the front plate and engage the gear teeth.
- b. Fit the push-pull switch slide into the back plate with the beveled end towards the middle.
- c. Fit Tab C into its slot. At the same time line up the rear cam hub with the hole in the rear plate. Line up Tabs A & B with their slots and snap together. Rebend Tab C first.
- d. While holding the plates together with one hand slide switch #2 into place so that its side bosses match the cutouts in both plates. When they are both properly seated rebend Tab B.
- e. Spread the plates apart so that you can slide Switch #1 into place. Be sure that its bosses are properly seated into both plates also. Press the plates together and rebend Tab A.
- f. Now Turn the timer so that you are looking into the contact end of the switch leaves. On the far right, the finger sticking up from the push-pull switch slider should be inside of the inverted U. All

# TIMERS & CIRCUITS

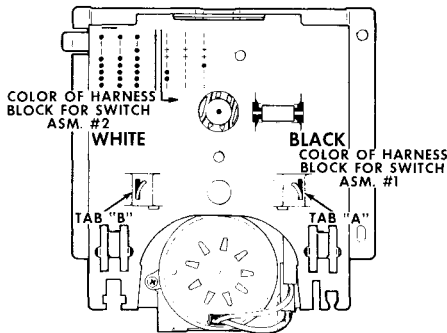
of the leaf guides should be setting square against the cam. If not, lift the ends of the switch leaves with your fingers just high enough to have them clear the cam rises and then let them fall freely into place. If the timer has a second switch bank do the same to its leaves.

- g. Reconnect motor leads.
- h. Rotate the cam 2 or 3 revolutions to insure that the cam followers are tracking properly.



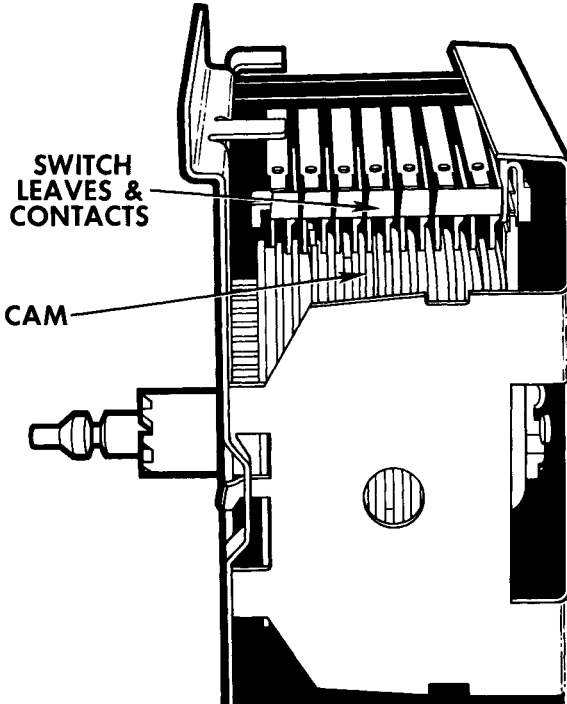
**Figure 10 — Rear View**

Figure 11 shows timer identification and harness block colors as related to the switch bank. The wiring label in the back-splash shows the switch leaf identification relative to the schematic.



**Figure 11 — Identification**

Figure 12 shows the correct position of the switch leaves relative to the cam. If the leaves are cocked and not riding squarely in the cam tracks, lift the ends of the leaves with your finger tips and let fall back into correct position.



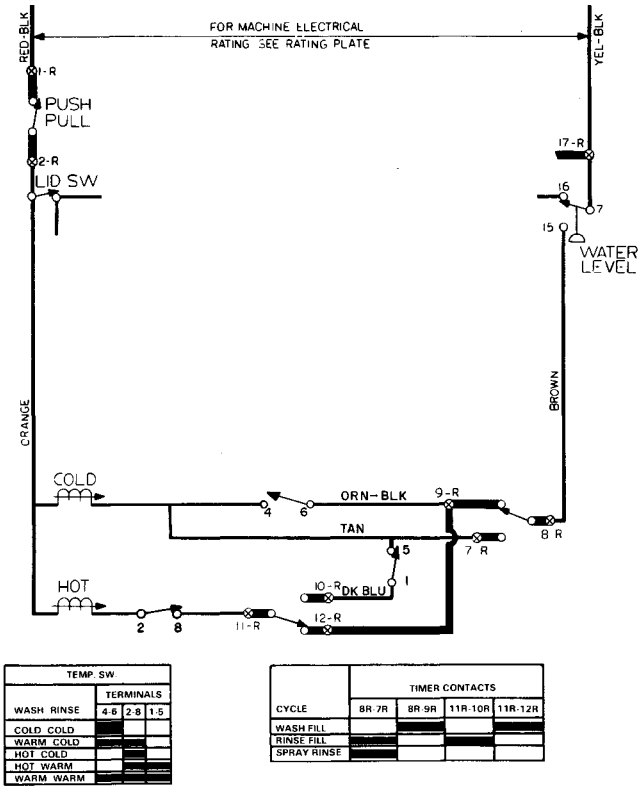
**Figure 12 — Correct Position of Switch Leaves**

Replace dust cover making sure tabs are in proper position (Figure 9).



# TIMERS & CIRCUITS

## BASIC CIRCUITS — SINGER TIMER FRESH WATER



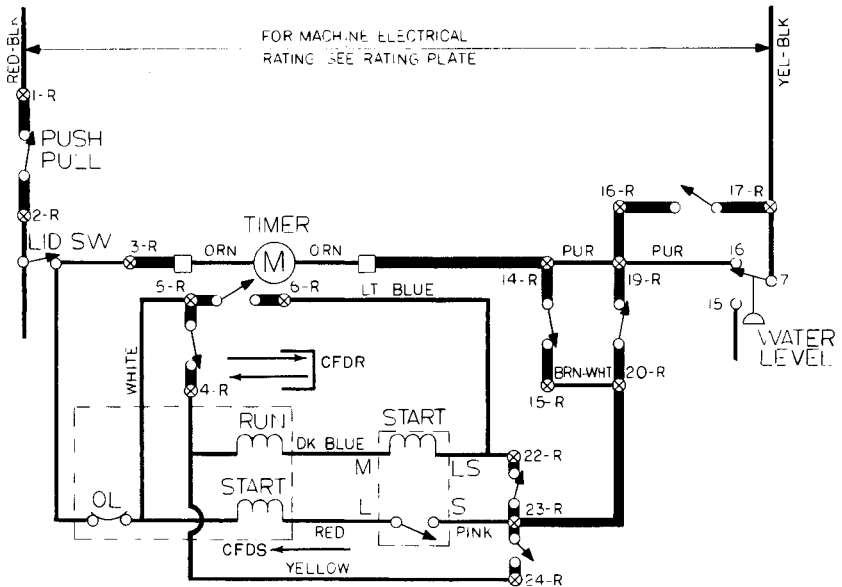
The partial schematic shows that water LEVEL is controlled by the water level switch (WLS). The TIME when the water enters the washer is determined by the timer switches. The TEMPERATURE is regulated by the temperature selector switches.

It can be seen that the WLS must be in its reset mode (7-15 closed) before any water can enter the washer. All other circuits such as the timer motor, drive motor, speed solenoid are isolated during wash and rinse fill. During spray rinse the other circuits are activated by the closing of the 16R-17R contacts (not shown).

Many models will not have the 1-5 selector switch contacts. They will not have any warm rinse fill or warm spray rinse. They will strictly be cold.

For specific details for a given model refer to the Mini-Manual in the backslash.

## BASIC CIRCUITS — SINGER TIMER TIMER & DRIVE MOTORS



CFDR-CURRENT FLOW DIRECTION THRU RUN WINDING  
CFDS-CURRENT FLOW DIRECTION THRU START WINDING

FUNCTION	TIMER SWITCHES							
	14R 15R	19R 20R	5R-4R	5R-6R	23R 22R	23R 24R	16R 17R	
AGITATE	■	■	■	■	■	■	■	
SPIN	■	■	■	■	■	■	■	

The partial schematic shows that the timer motor and the drive motor are in parallel circuits. They are both energized thru the water level switch (WLS) or timer contacts 16R-17R. Timer contacts 14R-15R and 19R-20R are the drive motor On-Off switches.

NOTE: It requires a fast make and break of switch contacts to reduce arcing, burning, and welding

To start the drive motor for either agitation or spin timer contacts 14R-15R have a fast make. Before they open with a slow break contacts 19R-20R close with a slow make. Because these switches are in parallel there is a continuous flow of current to the drive motor with no arcing of the contacts. At the end of the particular function contacts 19R-20R open with a fast break.

Timer contracts 4R-5R-6R and 22R-23R-24R are the drive motor reversing switches. These contacts make a break during times when 14R-15R and 19R-20R are open.

# TIMERS & CIRCUITS

## DRIVE MOTOR

The main winding and the start winding in the drive motor are in parallel circuits. The coil in the start relay is in series with the main motor winding. Before current is applied, the relay switch which is in series with the start winding, is open. When current is first applied the run winding is stalled and draws a high current. That same high current is also present at the relay coil which creates a strong magnetic field within the relay. This magnetic field closes the relay switch and completes the circuit to the start winding. The start winding gives a kick to the motor rotor which causes it to start turning. The current in the run winding now drops, removing the magnetic field, and the relay switch opens. The motor continues to turn on the run winding only. The start winding has its current removed in only a few seconds because its thin wires cannot withstand much current for any long period of time.

## AGITATION

The washer will not start to agitate until the WLS has been tripped—contacts 7-16 closed. For agitation timer contacts 5R-4R and 23R-22R are closed. In this condition it can be said that, at any given instant, the current in the run and start windings is flowing in the same direction. This would start the rotor turning in the clockwise direction — as viewed from the shaft end.

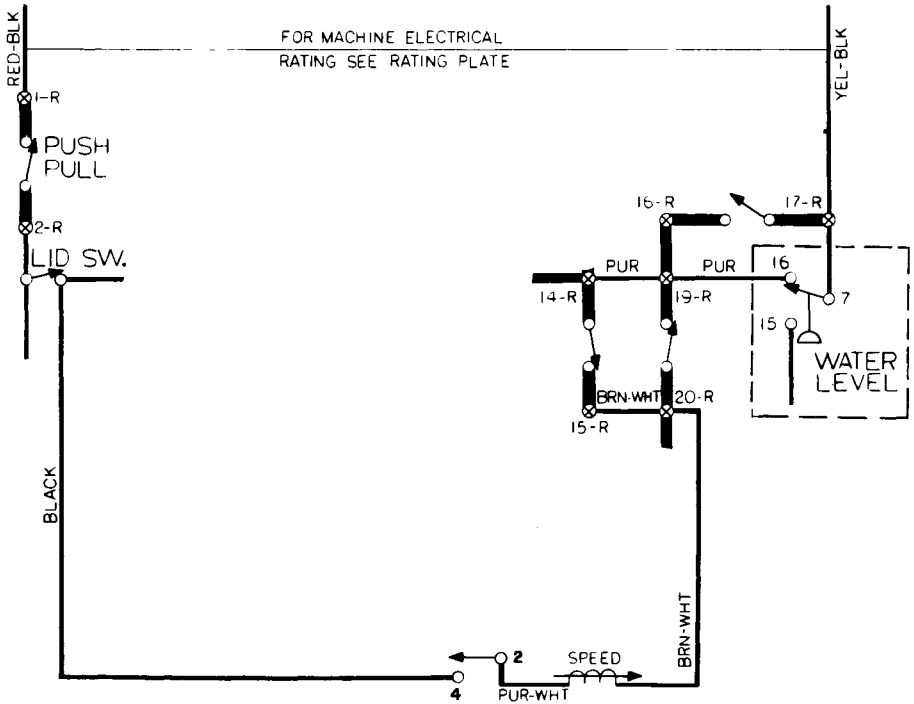
## SPIN

Timer switch contacts 16R-17R close just before the end of the agitation cycle to insure power to the drive motor when the water has been pumped out and the WLS resets (7-15).

For spin, timer contacts 5R-6R and 23R-24R are closed. In this condition it can be said that, at any given instant, the current in the run and start windings is flowing in opposite directions. This would start the rotor turning in the counterclockwise direction.

**BASIC CIRCUITS — SINGER TIMER  
SPEED SHIFTERS**

Two agitation and spin speeds are provided by a two-speed clutch and a speed shifter. The motor speed is constant. The clutch and shifter are the same for all 2-speed models.



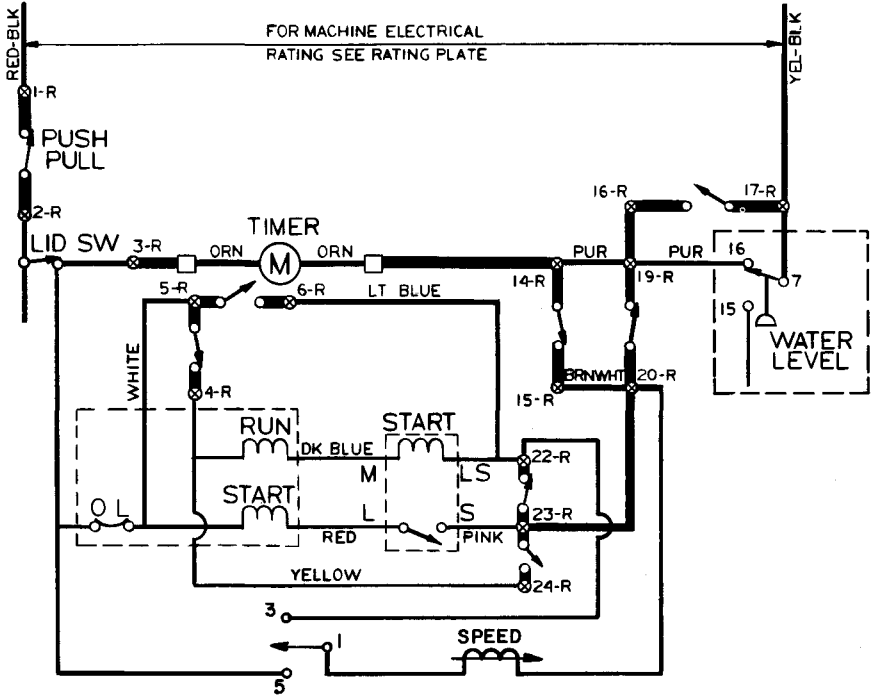
FOR MACHINE ELECTRICAL  
RATING SEE RATING PLATE

SECTION 50	
WATER LEVEL	15-16-7
WATER LEVEL	15-16-7
WATER LEVEL	15-16-7
WATER LEVEL	15-16-7
WATER LEVEL	15-16-7
WATER LEVEL	15-16-7
WATER LEVEL	15-16-7
WATER LEVEL	15-16-7
WATER LEVEL	15-16-7
WATER LEVEL	15-16-7

Speed shifter circuits come in several different forms. The simplest circuit is with the selector switch and shifter solenoid in series. These are in parallel with the drive motor. When selector switch contacts 2-4 are closed the washer provides gentle agitation and slow spin. This is called "locked speeds".

# TIMERS & CIRCUITS

## BASIC CIRCUITS — SINGER TIMER SPEED SHIFTERS



ACTION SW		
	TERMINALS	
	1-5	1-3
WASH/SPIN		
NORM/FAST		
NORM/SLOW		
GENT/SLOW		

FUNCTION	TIMER SWITCHES						
	14R-15R	19R-20R	5R-4R	5R-6R	23R-22R	23R-24R	16R-17R
AGITATE	■	■					
SPIN	■	■	■	■	■	■	■

A more complicated circuit, as shown in the partial schematic, provides three combinations of agitation and spin speeds. These are controlled by selector switch setting and the drive motor reversing switches in the timer. These switches are 4R-5R-6R and 22R-23R-24R. To get a gentle agitation in this example selector switch 1-5 must be closed. This also gives a slow spin so this part is the same as the "locked speeds". The motor reversing switches only affect the spin speed when selector switch 1-3 is closed.

Other models may have other combinations of speed selections. For specific details on a given model refer to the Mini-Manual in the backslash.





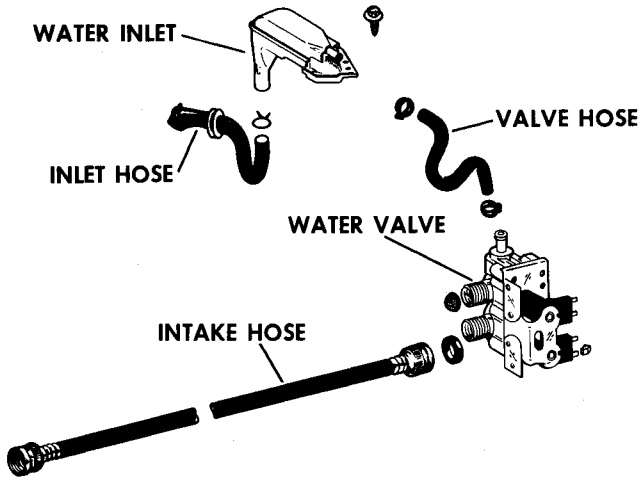
## INDEX

	PAGE
Drain Systems	C - 5
Fill System	C - 2
Hoses	C - 15
Overflow System	C - 3
Pressure Sensing Systems	C - 2
Pump - Non - Recirculating	C - 14
Pump - Recirculating	C - 13
Recirculation System	C - 4
Recirculation System - Spotscrubber	C - 4
Suds Save/Return Systems	C - 6
Suds Save/Return System A	C - 6
Suds Save/Return System B	C - 8
Tub and Basket	C - 15
Water Inlet Valve	C - 9
Water Level Switches (Pressure Switches)	C - 11
Water Retaining System	C - 4



# WATER SYSTEM

## FILL SYSTEM

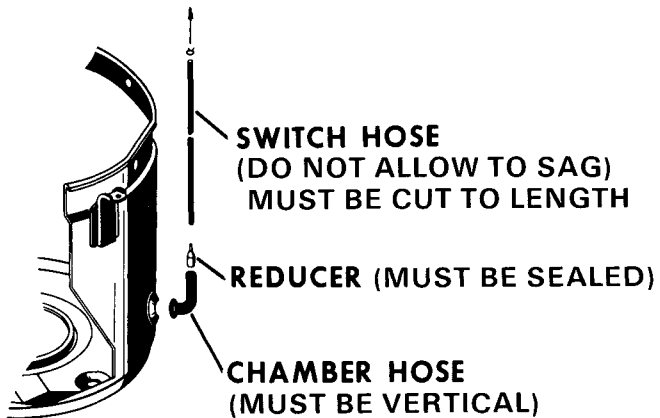


**Figure 1**

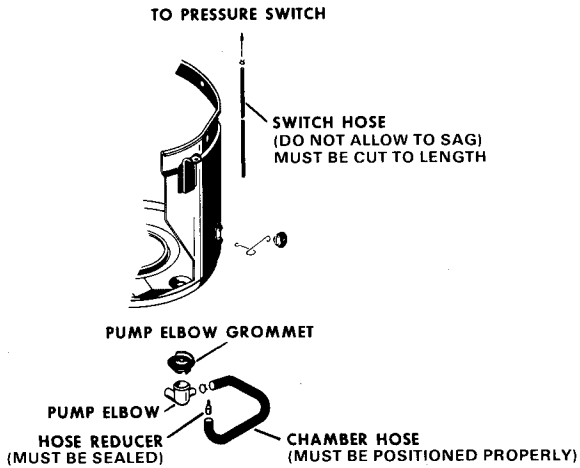
Water enters the water valve thru the intake hose. The valve is electrically energized to open either one or both intake ports. The water travels out the top of the valve, thru the valve hose, across the air gap in the water inlet, thru the inlet hose (nozzle) and into the tub and basket.

## PRESSURE SENSING SYSTEMS

### TO PRESSURE SWITCH



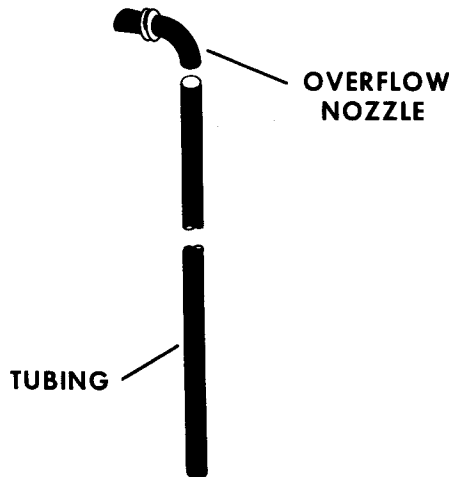
**Figure 2 — Side Pressure Take Off**



**Figure 3 — Bottom Pressure Take-Off**

As the incoming water rises in the tub, pressure is built up in the chamber hose. This pressure is transferred thru the reducer and switch hose to the water level switch. At the selected water level the diaphragm in the water level switch is deflected and the electrical energy is switched from the water valve to the motor and timer. The water level switches for the two systems cannot be interchanged.

**OVERFLOW SYSTEM**

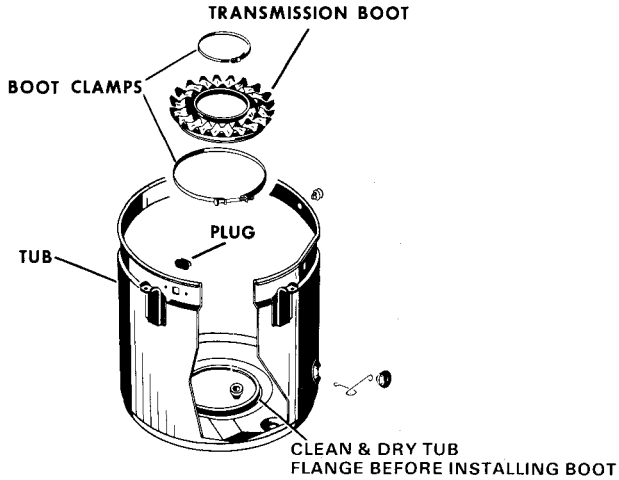


**Figure 4**

# WATER SYSTEM

If there should be a mechanical or electrical failure of the water valve and the incoming water fails to shut off, the overflow nozzle at the top of the tub will syphon the excess water down the tubing and out on to the floor. This will prevent flooding of the motor, clutch, and shifter.

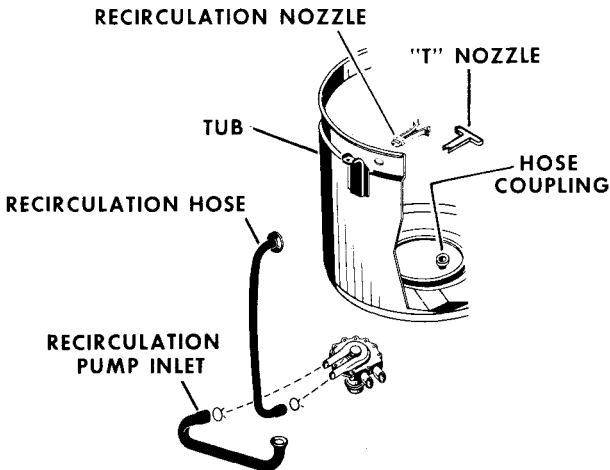
## WATER RETAINING SYSTEM



**Figure 5**

The tub, with its plugs, hoses, and other attachments is the prime water container. The transmission boot is the flexible member between the moving transmission and the fixed tub.

## RECIRCULATION SYSTEM (including Spotscrubber System)



**Figure 6**

During AGITATION the pump turns clockwise as viewed from the top. Recirculation water is taken off the bottom of the tub into the upper pump cavity and is pumped up thru the recirculation hose and nozzle.

## DRAIN SYSTEMS

### Side Pressure Take - Off

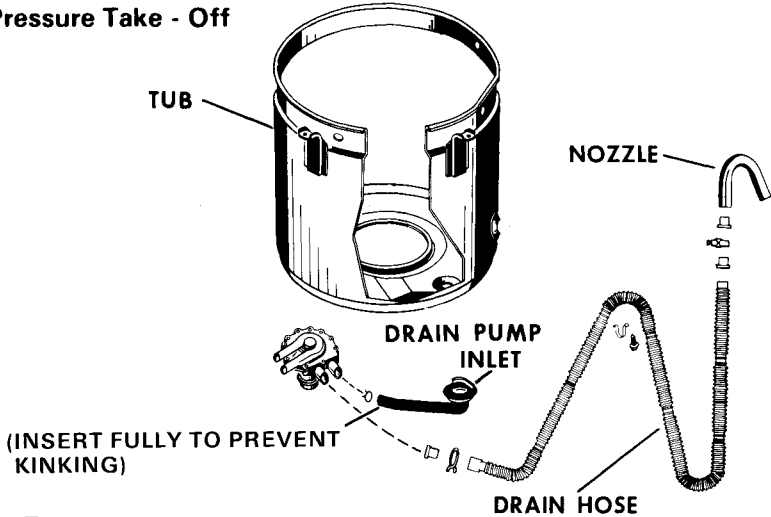


Figure 7

### Bottom Pressure Take-Off

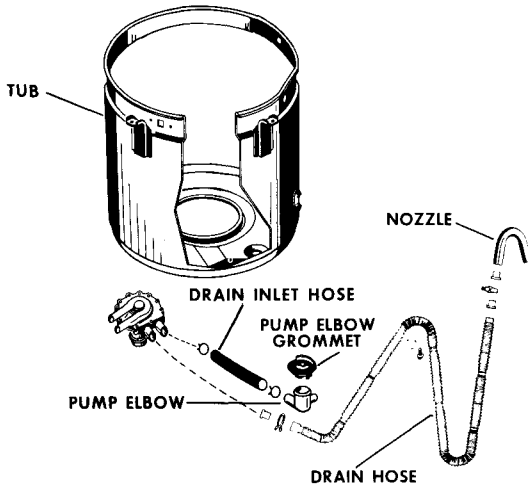
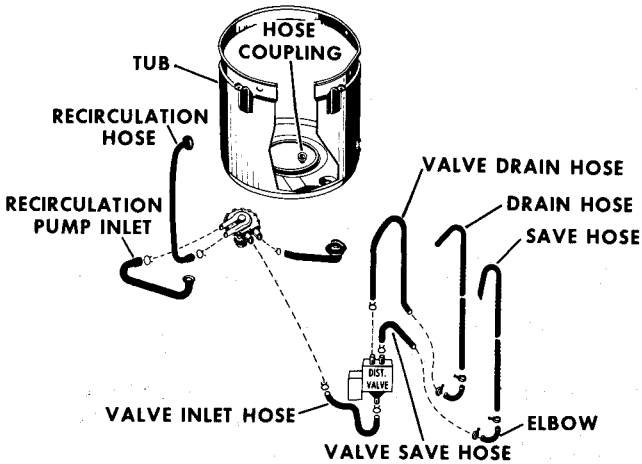


Figure 8

# WATER SYSTEM

Both systems are essentially the same. Water enters the lower cavity of the pump thru the drain inlet. The pump rotates counterclockwise as viewed from the top. Water leaves the pump thru the drain hose and nozzle.

## SUDS SAVE/RETURN SYSTEMS



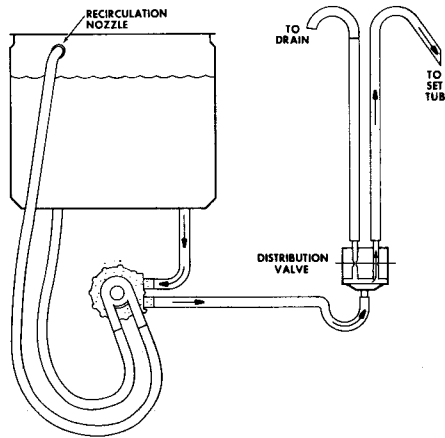
**Figure 9**

These systems allow the Wash water from the NORMAL cycle only to be saved in a set tub. This saved water can only be returned at the beginning of the NORMAL Wash cycle.

## SUDS SAVE/RETURN SYSTEM A

### Clam Shell Timer

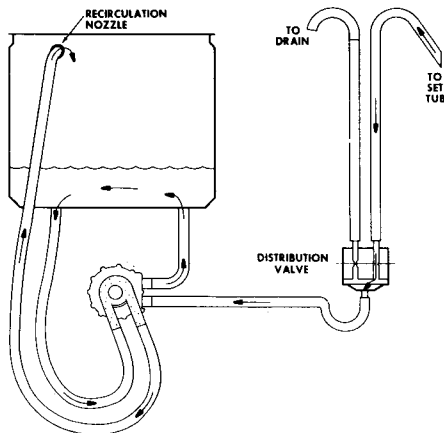
**SAVE:** With the customer control switch set on Save (3-A, D-2 closed) and Timer Switch No. 2 in the B mode at the beginning of WASH SPIN, the distribution valve solenoid is energized. The drain side of the valve is closed and the Save-Return side is open. The pump drives the used wash water into the single bottom port of the valve, out the top save port, and into the set tub, see Figure 10.



**Figure 10 — Water Flow During SAVE**

The valve solenoid remains energized for about 75-90 seconds into the Spin cycle and therefore, all of the Wash Water will not be saved. The remaining water goes down the drain after timer switch No. 2 changes to the A mode.

**RETURN:** With the customer control switch set on Return (D-1, 3-C closed) and timer switch No. 2 in the B mode at the beginning of the Wash, the distribution valve solenoid is energized. When the timer dial is turned to Wash and the knob is out, the pump and drive motor operate as in agitation. The pump pulls the saved water back through the Save-Return hose, through the valve, into the lower pump cavity, up into the bottom of the tub, out the tub into the pump upper cavity, and up through the recirculation hose and nozzle, see Figure 11.



**Figure 11 — Water Flow During RETURN**

## WATER SYSTEM

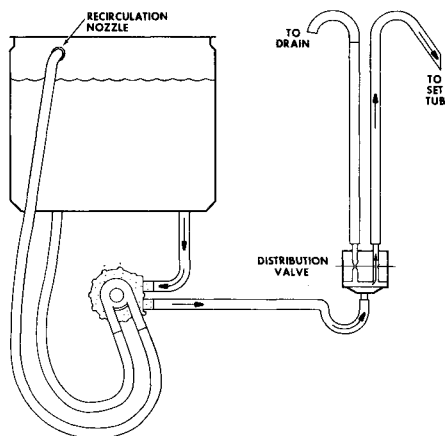
Normal operation calls for the user to turn the Save-Return switch to OFF (3-A closed) as soon as all of the saved water is returned. This will allow fresh make-up water to fill the washer to the desired level. The washer can then be loaded, detergent added, and when it is turned ON, the washer will complete the cycle in a normal manner.

If the Save-Return switch is not changed to OFF, agitation will continue for about 6 minutes into the Wash cycle when timer switch No. 2 will change to the A mode. The timer and drive motors will stop and make-up water will come in. This limits the time that the valve solenoid is energized and prevents burn outs.

### SUDS SAVE/RETURN SYSTEM B

#### Singer Timer

**SAVE:** With the customer control switch set on Save (3-A, D-2 closed) and Timer Switches 16L-17L and 19L-20L closed at the beginning of WASH SPIN, the distribution valve solenoid is energized. The drain side of the valve is closed and the Save-Return side is open. The pump drives the used wash water into the single bottom port of the valve, out the top save port, and into the set tub, see Figure 12.

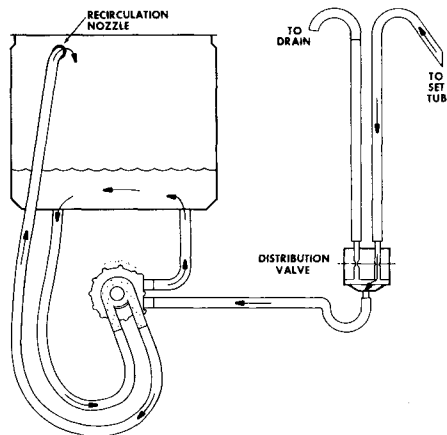


**Figure 12 — Water Flow During SAVE**

The valve solenoid remains energized for about 75 seconds into the Spin cycle and therefore, all of the Wash Water will not be saved. The remaining water goes down the drain after timer Switches 16L-17L and 19L-20L open.

**RETURN:** With the customer control switch set on Return (D-1, 3-C closed) and timer Switches 16L-17L and 19L-20L closed at the beginning of the Wash, the distribution valve solenoid is energized. When the timer dial is turned to Wash and the knob is out, the pump and drive motor operate as in

agitation. The pump pulls the saved water back through the Save-Return hose, through the valve, into the lower pump cavity, up into the bottom of the tub, out the tub into the pump upper cavity, and up through the recirculation hose and nozzle, see Figure 13.



**Figure 13 — Water Flow During RETURN**

Normal operation calls for the user to turn the Save-Return switch to OFF (3-A closed) as soon as all of the saved water is returned. This will allow fresh make-up water to fill the washer to the desired level. The washer can then be stopped, loaded, detergent added, and when it is turned ON, the washer will complete the cycle in a normal manner.

If the Save-Return switch is not changed to OFF, agitation will continue for about 5-1/2 minutes into the Wash cycle when timer switches 16L-17L and 19L-20L will open and 19L-21L closes. The timer and drive motors will stop and make-up water will come in. This limits the time that the valve solenoid is energized and prevents burn outs.

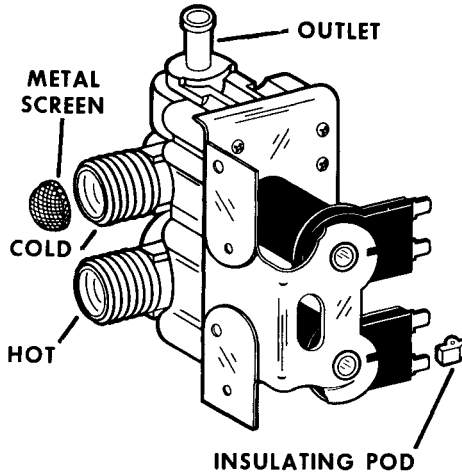
## WATER INLET VALVE

### Operation

1. This is a solenoid operated valve with an internal mixing chamber.
2. It is normal for this valve to have a one to two second delay in shutting the water off. DO NOT replace valve for this complaint only.
3. The top inlet is for COLD water and the bottom is for HOT water.
4. Both solenoids are actuated when a WARM selection is made. Approximately 60% COLD and 40% HOT water is combined in the internal mixing chamber to give a WARM temperature.



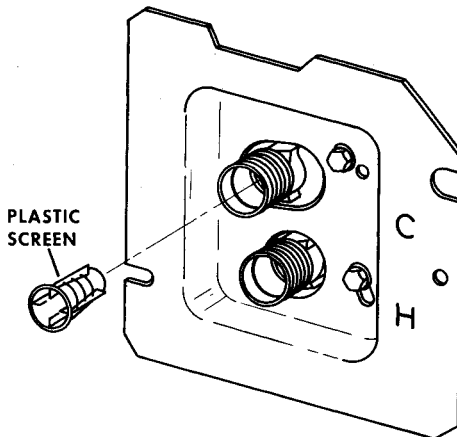
# WATER SYSTEM



**Figure 14**

The plastic valve body cannot withstand water temperatures over 180°F. Hot water temperature should be 140° to 150°F, as measured in wash basket full of hot water. This gives best washability results.

Figure 15 shows that the water inlet valve may be mounted tilted (15°) or nearly vertical. The tilted position is used on models with the plastic drain hose. All other models use the vertical position. The tilt reduces the possibility of cutting the plastic drain hose on the valve bracket.



**Figure 15**

For replacement purposes, the valve is stocked as a complete assembly only. However, the screens are replaceable.

Both plastic and metal screens have been used in production. The metal screens can replace the plastic but the plastic will not fit in place of the metal screens.

The plastic can be easily removed by gripping the internal vanes with pliers. The metal screens must be pried out and are usually deformed beyond use in the process.

## WATER LEVEL SWITCHES (PRESSURE SWITCHES)

### Location

Switch is located in the backsplash.

### Operation

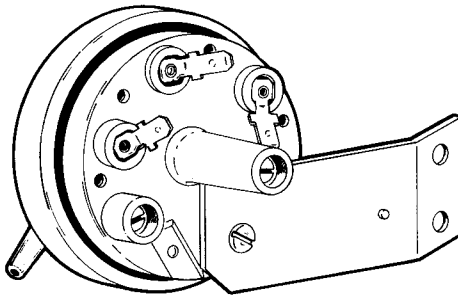
The water level switch is a SPDT switch, operated by a diaphragm which is connected through a sealed hose to an orifice in the bottom or side of the tub. As the tub fills, pressure within the hose and switch chamber exerts a force on the diaphragm. At the pressure point corresponding to the selected fill level, the deflecting diaphragm trips the switch, shutting off the water valve. At the trip point, it also completes the circuit to the timer and drive motors.

The pressure switch is preset at the factory to yield the proper fill level and should not be adjusted. Flooding or insufficient fill level complaints are usually caused by reasons other than poor calibration of the switch, i.e., restrictions in the chamber hose or hose reducer, cracked hose reducer, etc.

There are three basic types of water level switches in use.

- a. Fixed Level — Figure 16
- b. Toggle — Figure 17
- c. Rotary — Figure 18

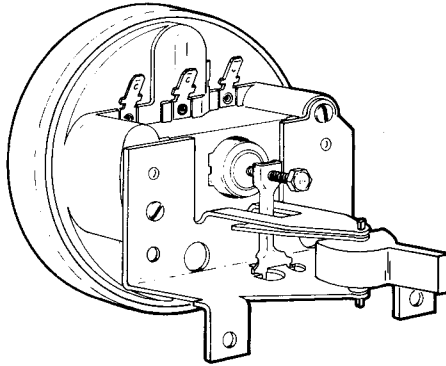
The rotary switches come in two variations — detented or infinitely variable.



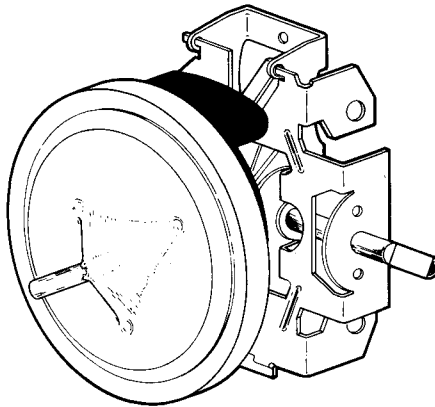
**Figure 16 — Fixed**

## WATER SYSTEM

**Note:** Harness terminals to pressure switch must not be allowed to touch when tension is placed on harness.



**Figure 17 — Toggle**



**Figure 18 — Rotary**

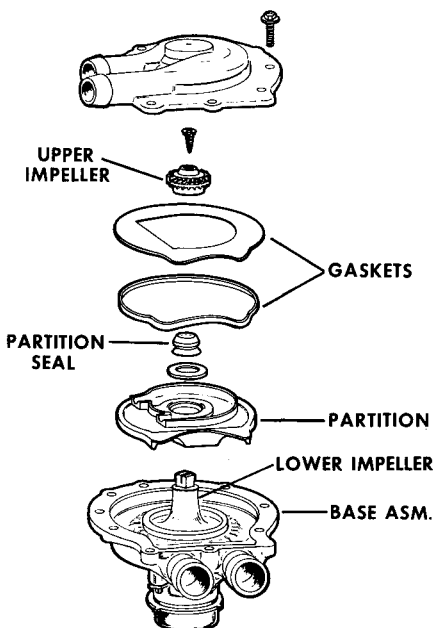
### Testing

Do not blow into pressure switch, with or without hose attached to check if switch is inoperative. Sudden increase in air pressure may trip switch, but not prove that it will trip at proper water level setting. It is recommended that switch be assembled and checked by running water into machine.

**PUMP — RECIRCULATING**

**Operation**

While pump replacement is by complete assembly only, the exploded view in Figure 19 is shown to help understand pump operation.



**Figure 19 — Recirculating Pump**

The pump is driven directly by the motor through the flexible coupling at motor speed.

During AGITATION, the pump turns clockwise. Recirculation water is taken off the bottom of the tub into the upper pump cavity and pumped up through the recirculation hose and nozzle.

During SPIN, the pump turns counterclockwise. Drain or save water is taken off the bottom of the tub into the lower cavity and out through the drain or save hose.

During SUDS RETURN, the pump turns clockwise. The saved water is drawn back into the lower cavity and up into the bottom of the tub. See Suds Save/Return Systems - Page C6 or C8.

# WATER SYSTEM

## Pump Flow Rate

The pump out rate at the pump outlet with no drain hose connected is:

60 HZ Models	17 GPM
50 HZ Models	14 GPM

However, for ease of checking in the home you can measure FULL FLOW PUMP DRAIN OUT TIME. This is the elapsed time between pump start and the beginning of the break up of the water flow at the drain nozzle — high level setting.

FULL FLOW PUMP DRAIN OUT TIME		
MODEL	NO LOAD	
	60 HZ	50 HZ
LARGE CAPACITY	110 Sec.	135 Sec.
STANDARD CAPACITY	95 Sec.	115 Sec.

If excessive drain out time exists:

1. Check entire drain hose for kinks.
2. Check for excessively long (over 10 ft.) or high (over 8 ft.) drain hose.
3. Check tub-to basket gap. See Page C - 15
4. On all models with a bottom pressure take-off check position of pump elbow grommet in bottom of outer tub. The wall should be downstream (left side) of drain opening. If incorrect, remove, rotate 1/2 turn, and reseal in tub using WH60X15 sealer.
5. Make sure pump is operating properly. Check with HOT water.
6. Check drain inlet hose for collapsing.

## PUMP — NON RECIRCULATING

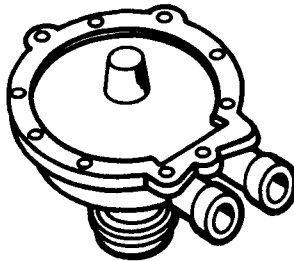


Figure 20

This pump is the same as the lower cavity of the recirculating pump and the same pump flow rate and service notes apply.

## HOSES

### 1. Hose-to-Tub Connection:

Some hoses are secured to the tub with an adhesive. To re-glue or to install a new hose:

- a. Clean off old adhesive.
- b. Insert hose into tub opening so that groove fits in opening.
- c. Lift flap inside tub and apply WH60X15 adhesive under and around flap.
- d. Wait about half an hour before putting water in tub.

### 2. Switch Hose, Chamber Hose:

- a. If the switch hose has been disconnected at either the WLS or the chamber hose when there was water in the tub, it must be cleared of all water before reconnecting. If the machine has not been emptied and the hose completely cleared, then overfilling may occur the next time the machine is used.
- b. After a cycle is completed, some water will remain in sump. If the water level switch is replaced, or if the machine is laid on its LEFT side (looking from front), water will be trapped in the chamber hose. This will cause overflow the first time water enters the machine.

When water level switch is replaced or machine laid on its LEFT side, fill machine to two or three inches of water in basket, then pump out. This will clear chamber hose of water.

## TUB AND BASKET

### Basket-To-Tub-Gap

See Suspension Cable - Pages E - 9, E - 10, E - 11

### Gasket Leaks

In some cases it may be necessary to shim up the tub brackets about 1/16" to get enough compression on the tub gasket for adequate sealing.

# WATER SYSTEM

## Basket & Hub Boot Removal

The hub boot has a finger which locks into a cut-out in the basket hub, see Figure 21. To remove boot, spread the locking finger and lift up on boot.

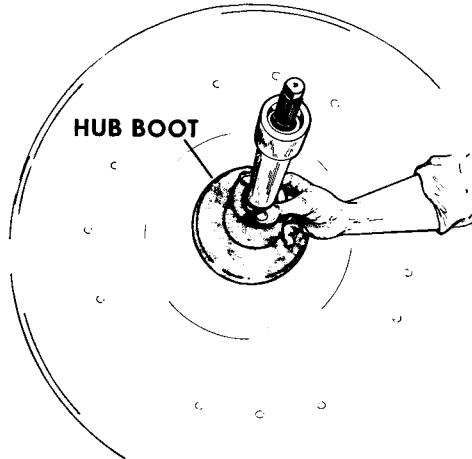


Figure 21 – Hub Boot

**NOTE:** It may be helpful to first remove as much of the lint and detergent deposits as possible. Then fill machine with enough **HOT** water to cover boot, which should soften boot material. Spin the water out and proceed as indicated above.

1. With hub boot removed, the three basket bolts may then be removed.
2. Remove recirculation nozzle. It is not necessary to remove rubber inlet nozzle.
3. Lift the basket straight up and out of the tub by holding on to the clothes retainer ring. Do not drag basket against tub.

## Transmission Boot

The basket must first be removed before removing the transmission boot. The boot is serviced from the top of the washer. Both of the boot clamps are accessible from inside the tub.

### NOTE:

To insure that the transmission boot is properly seated and that it will remain in place, properly sealed, **ALWAYS** wipe the inside of the boot and the tub flange clean and dry. Use liquid soap or detergent on the clamp screws for easier driving.

**INDEX**

	<b>PAGE</b>
Agitators	D - 14
Motor and Clutch - One Speed	D - 5
Motor and Clutch - Two Speed	D - 9
Motor and Relay	D - 2
Transmission	D - 19

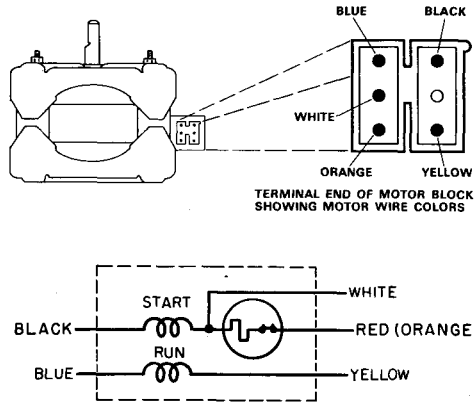


# DRIVE SYSTEM

## MOTOR AND RELAY

### Drive Motor

All washers are equipped with Form "T" drive motors



**Figure 1 — Colors Designate Wires Between Motor Receptacle and Motor Windings, Not Harness Wires.**

The direction of motor shaft rotation is determined by the reversing switch in the timer which sets the polarity of the motor run winding. The colors in the figure above designate wires between motor receptacle and motor windings, not harness wiring.

### Motor Specifications (Original Equipment)

#### **STANDARD CAPACITY** **1/3 H.P., 5KH42DT19S**

115V, 60 HZ, A.C.  
1725 RPM  
6.7 AMPS  
D.C. Resistance (Cold)  
Run Wind. — 1.78 Ohms  
Start Wind. — 3.62 Ohms  
Relay — 3ARR12KF41 or  
3ARR18J41M

#### **1/3 H.P., 5KH42ET15S**

220V, 50 HZ., A.C.  
1425 RPM  
3.3 AMPS  
D.C. Resistance (Cold)  
Run Wind. — 6.12 Ohms  
Start Wind. — 12.8 Ohms  
Relay — 3ARR12KF72

**1/3 H.P., 5KH42ET16S**

115V, 50 HZ., A.C.  
1425 RPM  
6.4 AMPS  
D.C. Resistance (Cold)  
Run Wind. 1.44 Ohms  
Start Wind 3.57 Ohms  
Relay — 3ARR12KF101

**1/2 H.P., 5KH42HT17S**

220V, 50 HZ., A.C.  
1425 RPM  
4.0 AMPS  
D.C. Resistance (Cold)  
Run Wind. 7.03 Ohms  
Start Wind. 13.5 Ohms  
Relay — 3ARR18J53L

**LARGE CAPACITY**  
**1/2 H.P., 5KH42GT2S**

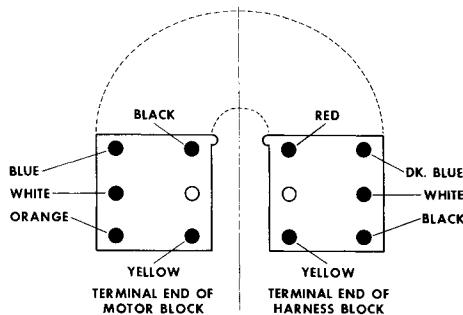
115V, 60 HZ., A.C.  
1725 RPM  
8.5 AMPS  
D.C. Resistance (Cold)  
Run Wind. — 1.26 Ohms  
Start Wind. — 3.05 Ohms  
Relay — 3ARR12KF285M  
or 3ARR18J37M

**STANDARD & LARGE CAPACITY**  
**UNRATED, 5KH42DT74S**

115V., 60 HZ, A.C.  
1725 RPM  
8.0 AMPS  
D.C. Resistance  
Run Wind. — 1.78 Ohms  
Start Wind. — 3.62 Ohms  
Relay — 3ARR12KF41 or  
3ARR18J41M

**1/2 H.P., 5KH42HT18S**

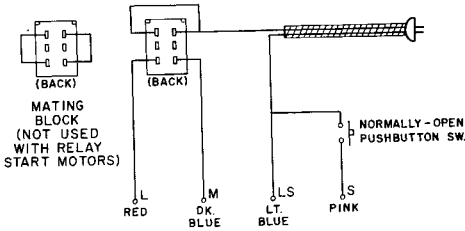
115V, 50 HZ., A.C.  
1425 RPM  
8.5 AMPS  
D.C. Resistance (Cold)  
Run Wind. 1.62 Ohms  
Start Wind. 3.21 Ohms  
Relay — 3ARR18J54L



**Figure 2 — Terminal Blocks At Motor**

# DRIVE SYSTEM

## Drive Motor & Relay Test



**Figure 3 - Motor Test Harness**

Use Motor Test Harness, WX5X184 (Fig. 3) and Harness Adapter, WH19X165. The Harness Adapter is available from your distributor and is required, in most cases, to match the test harness to the drive motor terminals.

### First - Test Motor Without Relay

1. Connect test harness block to connector block on motor.
2. Clip Lt. Blue and Dk. Blue alligator clips together.
3. Clip Pink and Red alligator clips together.
4. Plug test harness into wall receptacle.
5. Momentarily press push button.
6. If motor does not continue to run after releasing push button replace BOTH motor and relay.

### Second - Test Motor & Relay Together

1. Detach relay from cabinet rear, turn around, and reattach to cabinet.
2. Remove 4 wires from relay.
3. Attach test harness alligator clips to relay terminals.  
Dk. Blue to "M"                      Pink to "S"  
Red to "L"                              Lt. Blue to "LS"
4. Plug test harness into wall receptacle.
5. Momentarily press pushbutton.
6. If motor does not continue to run after pushbutton is released replace only relay.

**NOTE:** In order to prevent failure of replacement motors, always replace the motor start relay, also. Erratic operation of the relay could very well have been the cause of the original motor failure. The color of the label on the relay is NOT an accurate means of identification.

## MOTOR & CLUTCH – ONE SPEED

### Operation

When looking at the shaft end, the motor and clutch turn clockwise for agitation and counterclockwise for spin. The centrifugal force of the spinning primary shoes drives the drum, which drives the "V" belt. In agitation, the shoes "lock-in" almost immediately. In spin, the shoes can slip until enough force is built up to drive the transmission and wash basket.

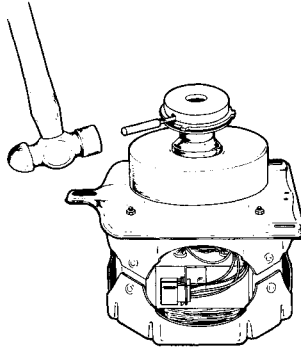
### Motor & Clutch Removal

1. Disconnect terminal block (s) at motor.
2. Remove lower flexible coupling clamp.
3. Remove three nuts securing motor mounting plate to suspension. (Use socket and ratchet.)
4. Lower the motor and clutch out the bottom of the washer by tilting the machine up at the rear.
5. Refer to Motor & Relay (Pg. D-2) for electrical function.

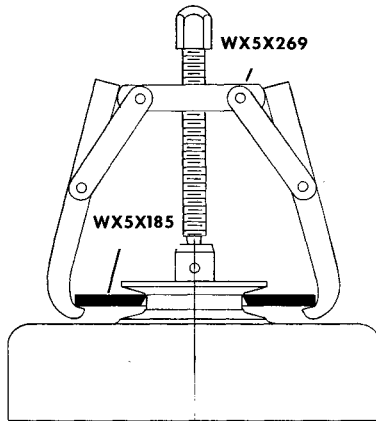
### Clutch Disassembly

1. Remove the clutch drive plate by using a WX5X147 drive pin tool to remove the roll pin holding the plate to the shaft extension, see Figure 4.
2. With the drive plate removed, the clutch may be disassembled. See Figure 6 for line-up of clutch parts.
3. For help in removing stubborn clutch drums, use horseshoe collar, WX5X185 as shown in Figure 5. Use of the collar prevents or reduces damage to the pulley portion of the drum.

# DRIVE SYSTEM



**Figure 4 – Roll Pin Removal**



**Figure 5**

Primary shoes should be replaced in pairs to insure proper clutch balance.

Bearing Replacement: WX5X166 Bearing Drive Tool is available for removing bearings and driving in replacement one in clutch drum.

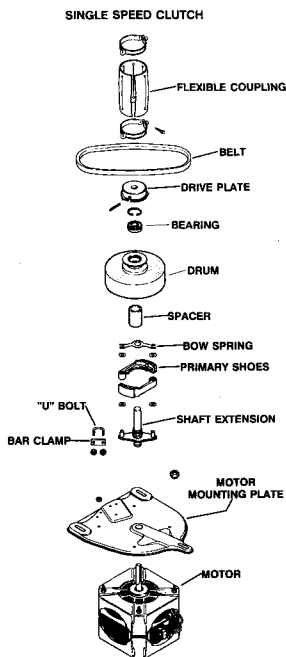


Figure 6

### Motor & Clutch Replacement

After clutch has been completely reassembled onto motor shaft —

1. Tilt washer forward and slide motor & clutch into place.
2. Lift motor & clutch up onto 3 studs in suspension and screw on 3 nuts by hand.
3. Fit belt into transmission and clutch drum pulley grooves.
4. Pull on motor with one hand and tighten outside mounting nut as shown in Fig. 7.
5. Tighten the other two nuts.
6. Reassemble flexible coupling and clamp.
7. SEE DRIVE BELT TENSION

### Flexible Coupling

One side is cord fabric, the other side smooth rubber. Assemble coupling with rubber side in.

# DRIVE SYSTEM

## Belt Replacement

1. Disassemble upper flexible coupling clamp.
2. Loosen the three nuts holding the motor mounting plate to the suspension. Use a socket & ratchet. Do NOT roll belt off or onto clutch drum pulley with a screwdriver. Loosen the three mounting bolts.
3. Remove old belt.
4. Fit new belt into transmission and clutch drum pulley grooves.
5. Pull on motor with one hand and tighten outside mounting nut as shown in Fig. 7.
6. Tighten the other two nuts.
7. Reassemble flexible coupling and clamp.

## Drive Belt Tension

The drive belt is correctly tightened when the belt can be deflected approximately 1/2", by pushing with the fingers.

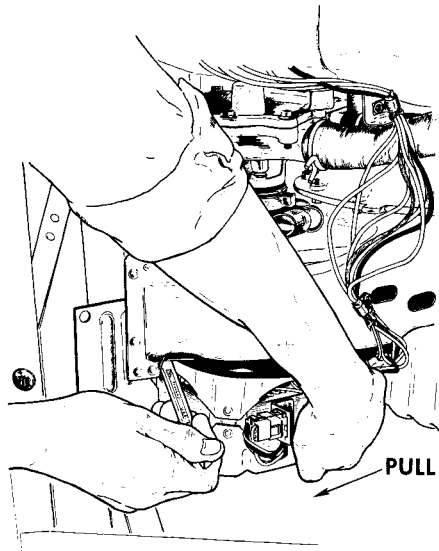


Figure 7 – Belt Tightening

## MOTOR & CLUTCH – TWO SPEED

### Operation

When looking at the shaft end, the motor and clutch turn clockwise for agitation and counterclockwise for spin. The centrifugal force of the primary shoes drives the inner drum, which drives the slip shoes, which drives the outer drum and belt. When the clutch shifter solenoid is energized, the lower carrier plate assembly is held stationary, preventing high speed locking action between the inner and outer drums. At approximately 420 RPM (basket speed), the slip shoes begin to pull away from the inner drum. The output of the clutch is then stabilized at this SLOW speed.

When the clutch shifter is not energized, the lower carrier plate is driven up to speed by the internal friction of the ball bearing between the carrier plate and the shaft extension. The inner and outer lock-in shoes on the carrier plate “lock-in” before the slip shoes pull completely away from the inner drum. The sequence of driving forces is from primary shoes to inner drum to inner lock-in shoes to carrier plate to outer lock-in shoes to outer drum to belt. The belt is driven at motor speed in the FAST or NORMAL mode.

### Motor & Clutch Removal

1. Disconnect terminal block (s) at motor.
2. Remove lower flexible coupling clamp.
3. Remove three nuts securing motor mounting plate to suspension. (Use socket and ratchet.)
4. Lower the motor and clutch out the bottom of the washer by tilting the machine up at the rear.
5. Refer to Motor & Relay (Pg. D-2) for electrical function.

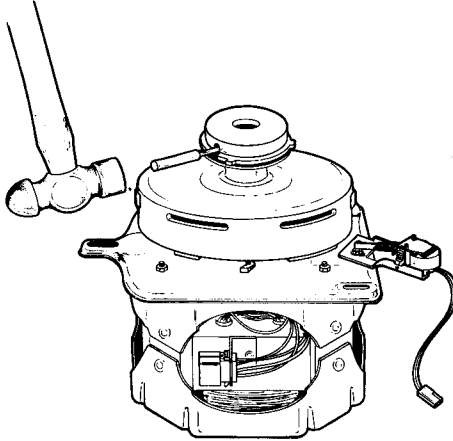
### Clutch Disassembly

1. Remove the clutch drive plate by using a WX5X147 drive pin tool to remove the roll pin holding the plate to the shaft extension, see Figure 8.
2. With the drive plate removed, the clutch may be disassembled. See Figure 10 for line up of clutch parts.
3. For help in removing stubborn clutch drums, use horseshoe collar, WX5X185, as shown in Figure 9. Use of the collar prevents or reduces damage to the pulley portion of the drum.

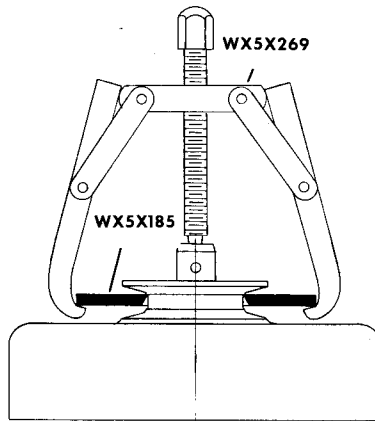


## DRIVE SYSTEM

4. For help in removing stubborn shaft extension from the motor shaft, hold the motor shaft under the shaft extension with a thin pair of vice grips and twist the shaft extension with a pair of channel lock pliers.



**Figure 8 – Roll Pin Removal**



**Figure 9**

Primary shoes should be replaced in pairs to insure proper clutch balance.

Bearing Replacement: WX5X166 Bearing Drive Tool is available for removing bearings and driving in replacement one in clutch drum.

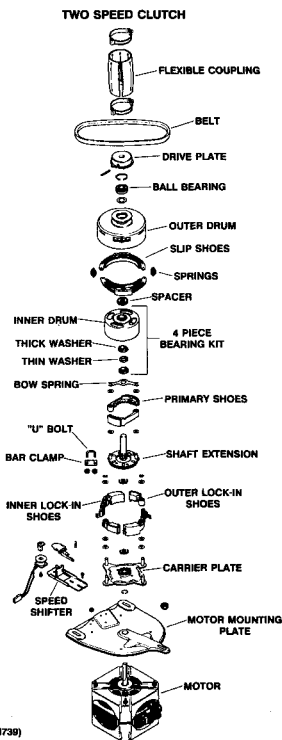


Figure 10

## Shifter Adjustment

(ART NO. WH739)

The speed shifter should be adjusted before reassembling the motor & Clutch back into the washer.

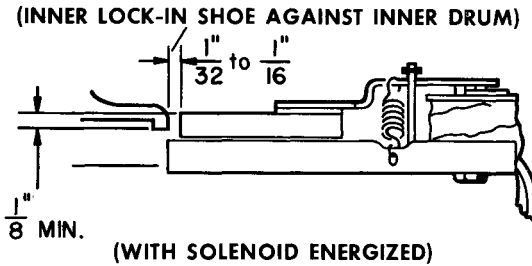
1. With inner Lock-In Shoe against inner drum (position when clutch is operating at fast speed), there should be  $1/32''$  to  $1/16''$  clearance between tab on shoe and end of catch assembly arm (with solenoid energized). This insures that the catch will not engage the shoe tab if the solenoid is energized after the clutch is up to speed. Adjust by moving solenoid mounting bracket in or out (loosen two mounting screws to adjust), Figure 11.
2. With solenoid not energized and inner lock-in shoe in relaxed position, shoe tab should pass over top of catch arm with ample clearance. There should be  $1/2'' + 1/32''$  spacing from bottom of shoe tab to solenoid mounting bracket, Figure 11.
3. With solenoid energized, there should be  $1/8''$  to  $7/32''$  interference between end of catch arm and shoe tab. Tab should engage catch arm at an angle of approximately  $15^\circ$  in direction of counterclockwise rotation. Adjust by rotating solenoid mounting bracket, Figure 12.

## DRIVE SYSTEM

In the raised position, the top of the shifter arm should overlap the bottom of the shoe finger by at least  $1/8''$ .

The shifter asm. can be raised by putting a washer around each of the mounting screws and between the shifter bracket and the motor support.

Do not bend the shifter arm.



## MOTOR & CLUTCH REPLACEMENT

After clutch has been completely reassembled onto motor shaft —

1. Tilt washer forward and slide motor & clutch into place.
2. Lift motor & clutch up onto 3 studs in suspension and screw on 3 nuts by hand.
3. Fit belt into transmission and clutch drum pulley grooves.
4. Pull on motor with one hand and tighten outside mounting nut as shown in Figure 13.
5. Tighten the other two nuts.
6. Reassemble flexible coupling and clamp.
7. SEE DRIVE BELT TENSION

## Flexible Coupling

One side is cord fabric, the other side smooth rubber. Assemble coupling with rubber side in.

## Belt Replacement

1. Disassemble upper flexible coupling clamp.
2. Loosen the three nuts holding the motor mounting plate to the suspension. Use a socket & ratchet. Do NOT roll belt off or onto clutch drum pulley with a screwdriver. Loosen the three mounting bolts.
3. Remove old belt.
4. Fit new belt into transmission and clutch drum pulley grooves.
5. Pull on motor with one hand and tighten outside mounting nut as shown in Fig. 13.
6. Tighten the other two nuts.
7. Reassemble flexible coupling and clamp.

## Drive Belt Tension

The drive belt is correctly tightened when the belt can be deflected approximately 1/2", by pushing with the fingers.

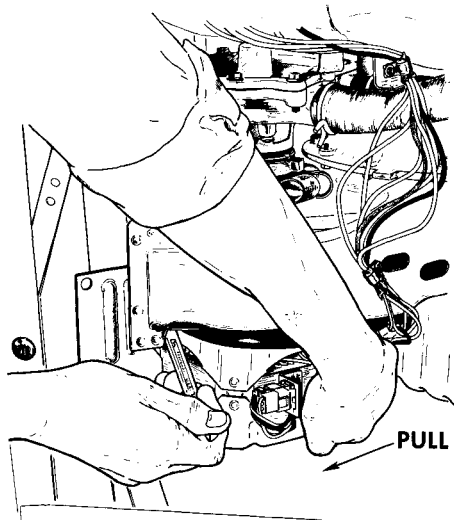


Figure 13

# DRIVE SYSTEM

## AGITATORS

### Agitator to Basket Clearances

1. The clearance should be as shown in Figure 14. A shim is installed at the factory inside the agitator support to achieve the proper gap. The agitator to basket clearance may be reduced by removing the shim washer.

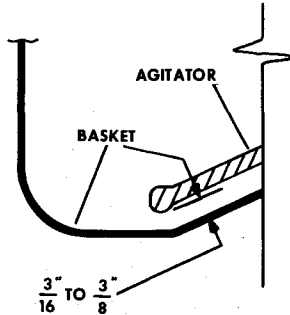


Figure 14 – Agitator to Basket Clearance

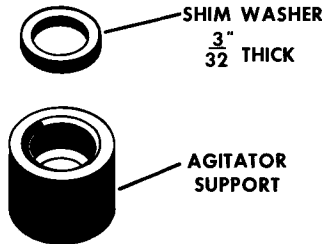


Figure 15 – Agitator Shim Washer

2. A worn agitator bottom and/or hub boot will affect basket to agitator clearance. Replace one or both parts when excessive side to side movement of the agitator exists.

### Agitator Coupling

1. To prevent corrosion build-up and freezing of the agitator coupling to the splined shaft of the transmission, the agitator should be removed periodically. At this time, clean the shaft splines and apply a good quality water pump or wheel bearing grease, sparingly.
2. If agitator coupling does become frozen to the shaft spline, the following procedure may be helpful:

### One Piece Types

On earlier models the vinyl filter mount must be removed from the top of the agitator. On the more recent models, without a separate filter mount, the plastic cap must be snapped off and the web in the center of the agitator must be cut out. This will expose the end of the agitator shaft and the agitator coupling. Pouring hot water or a few drops of penetrating oil on the shaft and coupling may help to loosen the agitator from the shaft. Tapping lightly on the end of the shaft while pulling up on the agitator could also help break it loose. If these steps fail then use the Agitator Puller Collar (WX5X349) with a wheel puller. This should at least pull off the agitator leaving the agitator coupling still frozen to the shaft. It will probably be easier to replace the coupling than to try to remove it from the Shaft.

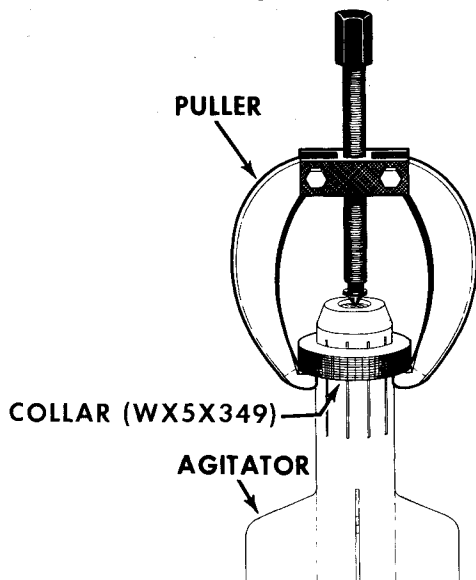


Figure 16

Sometimes it may be necessary to resort to a hacksaw or to a hammer and chisel to remove the agitator. This should be done only as a last resort because it destroys the agitator.

# DRIVE SYSTEM

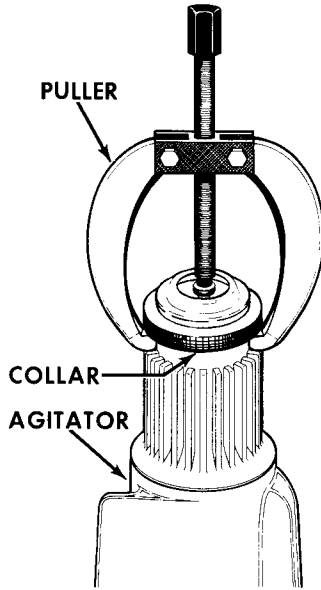


Figure 17

## Two Piece – Non Convertible Type

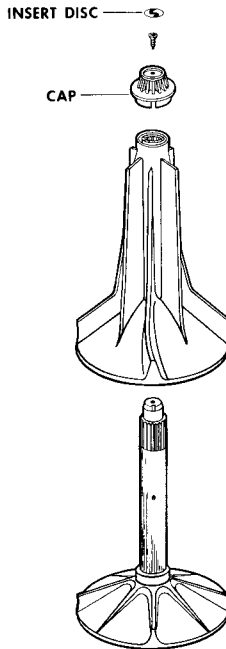


Figure 18

## Disassembly

Pry metal foil disc off top of agitator. Remove one screw. An adhesive activator must be used to install a new foil disc.

- a. Disassemble outer agitator. Thru the screw hole apply a slow steady stream of HOT water to the shaft and coupling. It may be necessary to also use a loosening oil at this point. Pull up steadily until the coupling and /or agitator comes off. At the same time, tap on the end of the agitator shaft with a hammer or mallet. Many times this extra vibration will make it easier to remove the agitator and/or coupling.

OR — Use Agitator Puller Collar, WX5X349, with a wheel puller as shown in Fig. 17.

## Two Piece — Convertible Type

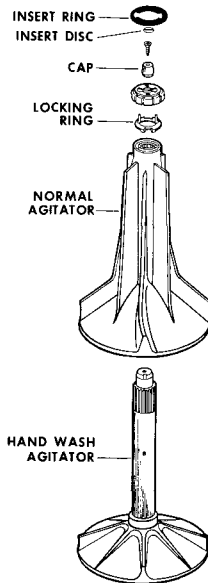


Figure 19

## Conversion to HAND WASH

Twist or rotate the locking tabs as indicated on top of the agitator. Lift off outer agitator.

## Disassembly of LOCKING MECHANISM —

Pry metal foil ring off top of locking mechanism. Remove two screws. An adhesive activator must be used to install a new foil ring.



## **DRIVE SYSTEM**

### **Disassembly of HAND WASH Agitator Cap —**

Pry metal foil disc off top of agitator. Remove one screw. An adhesive activator must be used to install a new foil disc.

Unlock and remove NORMAL agitator. REMOVE disc and screw from HANDWASH agitator. THRU the screw hole apply a slow steady steam of HOT water to the shaft and coupling.

It may be necessary to also use a loosening oil at this point. Pull up steadily until the coupling and/or agitator comes off. At the same time, tap on the end of the agitator shaft with a hammer or mallet. Many times this extra vibration will make it easier to remove the agitator and/or cooling.

OR — Use Agitator Puller Collar. WX5X349, with a wheel puller as shown in Fig. 17.

### **Coupling Removal (frozen to Transmission)**

b. To remove an agitator coupling which remains frozen to the transmission agitator shaft after the agitator has been removed, use puller WX5X269 along with puller collar Wx5X263. These tools are available from your distributor.

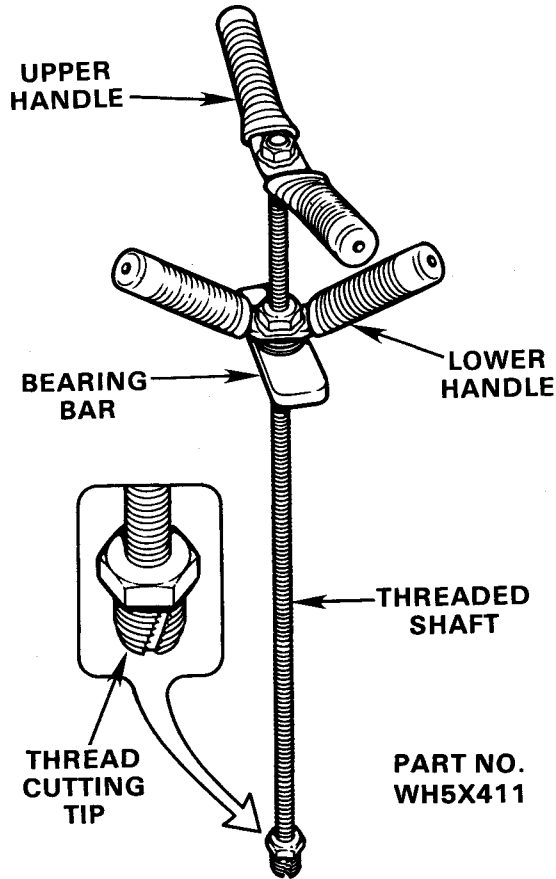
Procedure:

1. Cut the agitator support and remove it.
2. Insert the puller collar between the agitator coupling and agitator shaft seal, flat side down.
3. Attach the puller under the puller collar. Seat the puller screw on the end of the agitator shaft and apply torque.
4. Clean up the agitator shaft splines and apply good quality pump or wheel bearing grease, sparingly.

c. Agitator Coupling Replacement Tool:

### **WASHER AGITATOR COUPLING PULLER (FOR AGITATORS WITHOUT BOTTOM COVERS)**

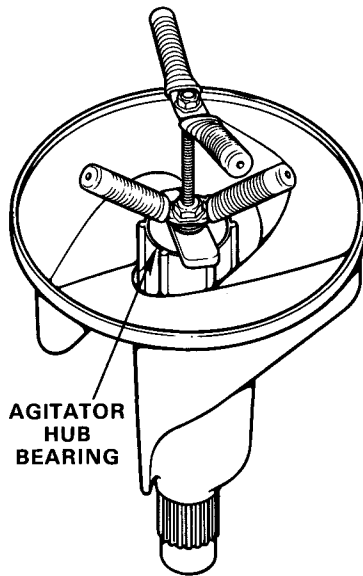
A special tool (WX5X411) is available to make it much easier to remove a worn agitator coupling from inside an agitator. The upper handle is fixed to the threaded shaft. The lower handle and bearing bar move up and down on the shaft as the lower handle is turned.



To remove an agitator coupling:

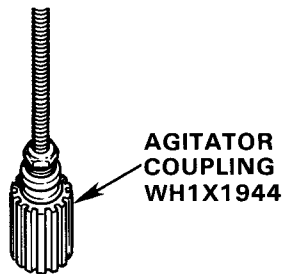
1. Turn the lower handle on the shaft until it is about 3 inches from the upper handle.
2. Turn the agitator upside down.
3. Place the thread cutting tap into the aluminum insert of the coupling.
4. Press down and turn the upper handle clockwise so the tap cuts its way into the coupling insert. Turn several times to insure a good bite.
5. Turn the lower handle clockwise until the bearing bar is resting on the agitator hub bearing.
6. Adjust the shaft and bar so that they are centered across the agitator hub bearing.
7. Continue turning the lower handle until the coupling is pulled free of the agitator.

# DRIVE SYSTEM



To replace an agitator coupling: (Option #1)

1. Place the new agitator coupling over the splined shaft on the transmission.
2. Use of an adhesive for lubrication on the rubber coupling splines will make it easier to press the agitator completely onto the coupling.
3. **DO NOT USE ANY TYPE OF OIL ON THE RUBBER SPLINES OF THE COUPLING.**
4. Place the agitator over the coupling and firmly press the agitator down.



A tool may be made up for installing a new agitator coupling (WH1X1944) into an agitator, as follows:

Parts Needed:

1. Agitator shaft (WH40X152), retaining ring (WH2X786), and spacer (WH2X581).

2. Place the retaining ring in agitator shaft groove. Weld retaining ring and spacer to the agitator shaft, Figure 20.



**Figure 20 – Coupling Replacement Tool**

**Installation of new Agitator Coupling (WH1X1944):**

1. Lubricate rubber surfaces with XYLOL solution.
2. Place coupling on assembly tool. Insert through bottom of agitator in position to be driven into place.
3. Place agitator on a solid surface, top down. Drive coupling into agitator until fully seated.

**NOTE:** Use only XYLOL, obtainable from a solvent supply house. Other lubricants will deteriorate the rubber part of the coupling.

**TRANSMISSION**

**A. Operation**

**AGITATION:** Latch slide engages brake band tab inside bearing frame, holding gearcase and thus washbasket steady. Pulley is turned CCW (looking from bottom). Torque is transmitted from pinion shaft, through geartrain to agitator shaft, then to agitator.

<b>SPEEDS:</b>	<b>NORMAL</b>	<b>SLOW (2 SPEED MODELS ONLY)</b>
Agitation	100 osc./min.	70 osc./min.
Spin	600 ± 10 RPM	420 ± 10 RPM

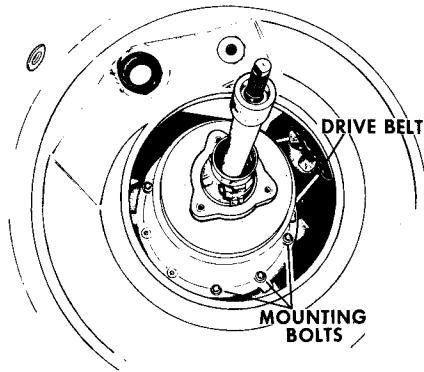
**SPIN:** Latch slide is disengaged from brake band by latch tube movement, when pulley is turned CW (looking from bottom). Gearcase and tubes assembly rotates as a unit, driven by clutch spring, which tightens on latch tube. Torque is transmitted from drive tube through basket hub to washbasket.

# DRIVE SYSTEM

## Transmission Removal

The cover, wash basket, and transmission boot must be removed before removing the transmission. See Basket & Hub Boot Removal Section, Page C - 16.

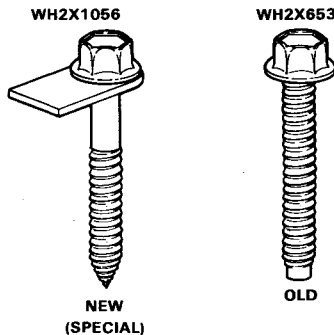
1. Remove the six bolts; use a 3/8" socket with at least a 6" extension, see Figure 21.
2. Disengage the belt and lift the transmission up and out of the machine.



**Figure 21 - Transmission Mounting**

## Transmission Installation

NOTE: Both a metal and a plastic gear case cover have been used in production and in rebuilding transmissions. The plastic gear case cover requires special mounting screws. This special screw **MUST** be used to reinstall any transmission, with a plastic gear case cover, to the suspension - 6 per. This special screw has also been used to install transmissions with metal gear case covers. **DO NOT** use the old screws to mount a transmission with a plastic gear case cover.



**Figure 22 - Transmission Mounting Screws**

To reinstall the transmission —

1. Position transmission with plastic covers on suspension with vertical rib opposite pump.
2. Screw in one of the two mounting bolts nearest the clutch. Do not tighten.
3. Position the drive belt on the clutch and transmission pulleys.
4. Pivot the transmission and install the five remaining mounting bolts.
5. After reinstalling the transmission in the washer, be sure that ...
  - a. Drive belt is put back on properly.
  - b. Transmission boot clamps are securely fastened to outer tub and transmission.

**NOTE:**

To insure that the transmission boot is properly seated and that it will remain in place, properly sealed, **ALWAYS** wipe the inside of the boot and the tub flange clean and dry. Use liquid soap or detergent on the clamp screws for easier driving.

- c. Hub boot is properly reinstalled.

Check machine through complete cycle (rotating timer by hand) after completing installation of transmission. Check for any leaks and for proper operation in spin and agitation.

### **AGITATOR SHAFT SEAL LEAK**

If the agitator shaft seal has leaked oil, check the inside of the agitator for grease or oil. Remove screws and bottom (if present) and thoroughly wipe out any grease or oil with rag or paper towel. Do not use a solvent to clean inside of agitator. Reassemble and replace agitator.



# CABINET CONSTRUCTION & SUSPENSION SYSTEM

## INDEX

	<b>PAGE</b>
Backsplash	E - 2
Cover	E - 3
Cover Shield & Hinges	E - 3
Field check for machine walking, strike, vibration	E - 11
Leveling System	E - 7
Lid Switch	E - 5
Suspension	E - 7
Suspension Cable	E - 9
Tub to Basket Gap	E - 10



# CABINET CONSTRUCTION & SUSPENSION SYSTEM

## BACKSPLASH DISASSEMBLY

Low Style (6 inch)

1. Remove 2 screws "A".
  2. Remove 2 screws "B".
  3. Roll top of escutcheon towards front of washer.
- Timer and Switches are now accessible.

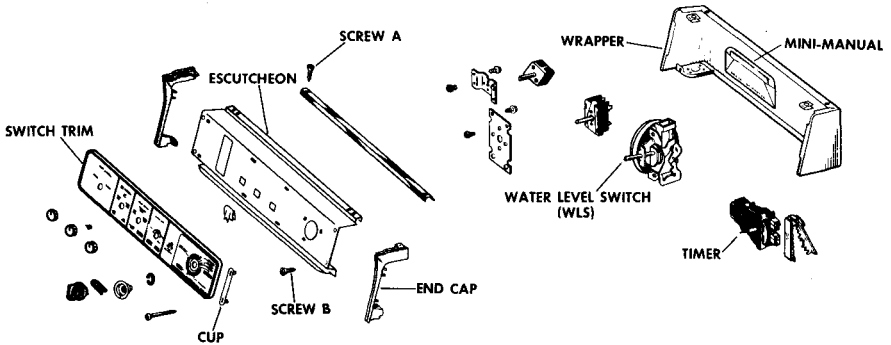


Figure 1—6 Inch Backsplash—Exploded View

High Style (7 inch)

1. Remove 2 screws "A".
  2. Lift rear of top trim and roll towards front of washer.
  3. Remove 2 screws "B".
  4. Remove 2 screws "C".
  5. Roll top of escutcheon towards front of washer.
- Timer and Switches are now accessible.

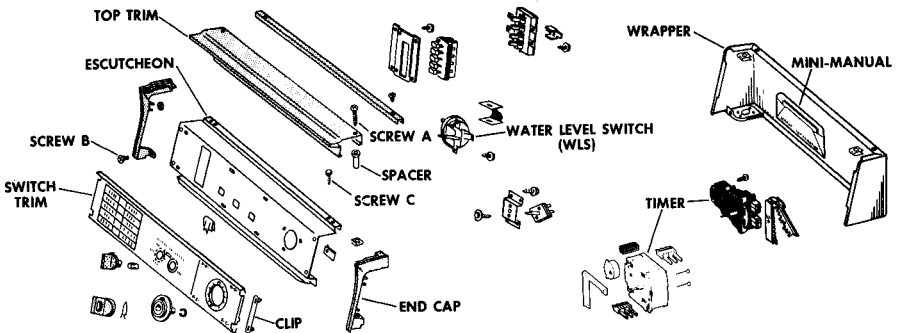


Figure 2—7 Inch Backsplash—Exploded View

## COVER ASSEMBLY

### Description

The washer cover is attached to the cabinet by two spring clips at the front and two at the rear.

### Cover Removal

1. Push in on spring clips securing the front of the cover, Figure 3, then raise the cover. Recommended tools for releasing the cover spring clips are a wooden or plastic wedge, or a one-inch putty knife.



**Figure 3—Cover Removal**

**CAUTION:** The cover may be chipped if a large-bladed screwdriver is used to release the cover spring clips.

### 2. BEFORE RAISING COVER:

**TM**  
On Dispensal models, the separator tabs must first be detached from the plastic cover shield. If this is not done before raising the cover, the molded pins on the diverter may be broken off.

### 3. REASSEMBLY

- a. Hook the rear cover flange over the two rear cover spring clips.
- b. Pull the cover forward over the front cover spring clips and press down until the clips snap in place.
- c. Be sure that wires and water level switch hose are not trapped between cover and apron.
- d. Reinsert separator tabs or recirculation nozzle through cover shield.

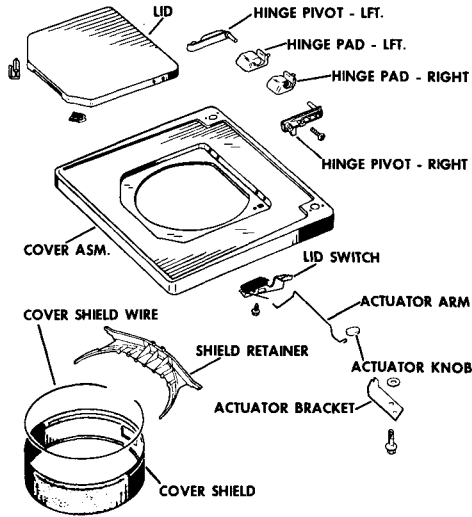
## COVER SHIELD & HINGES

### Description

The plastic cover shield is attached to the flange on the underside of the cover.

A rigid plastic shield retainer supports and correctly shapes the shield at the rear of the loading hole. Both the shield and retainer are fastened to the cover by a wire loop, Figure 4.

# CABINET CONSTRUCTION & SUSPENSION SYSTEM



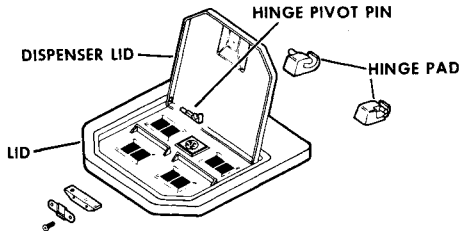
**Figure 4—Cover & Lid**

The hinge pads and pivots are plastic. With the all plastic hinge, it is necessary to raise the cover to change the lid. Both hinge pads must be removed. The right hinge pivot rotates the actuator arm, which actuates the lid switch.

## <sup>TM</sup> Dispensall Models

The Dispensall models do not have separate hinge pivots. They are built into the hinge pads. The lid switch trip finger is part of the plastic lid.

To remove Dispenser Lid slide Hinge Pivot Pin to the right.



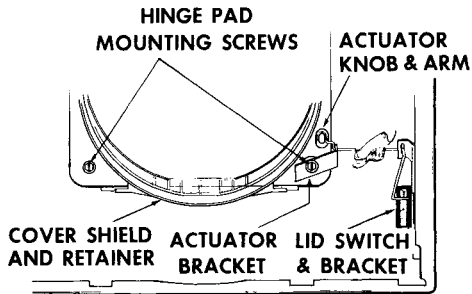
**Figure 5—Dispensall Lid Asm.**

## LID SWITCH

### Description

This lid switch and linkage assembly provides for a two-inch maximum lid opening to stop the machine. Measuring between the lower front edge of the lid and the flat surface of the lid well, the lid switch **MUST OPEN** with a maximum gap of 2.0 inches and **CLOSE** with a minimum gap of .800 inches.

Figure 6 shows the mounting and location of the cover shield, lid hinges, and the lid switch.



**Figure 6—Underside of Cover**

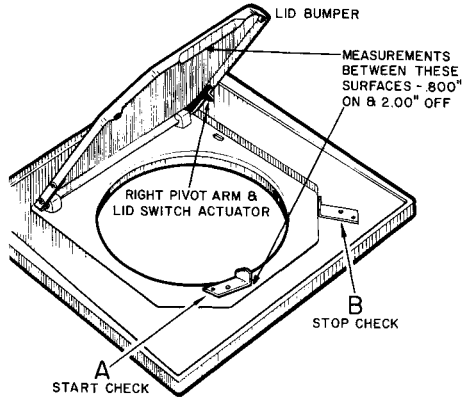
### Adjustment

Whenever any components are replaced which would affect the maximum and minimum settings given above, the following check must be made:

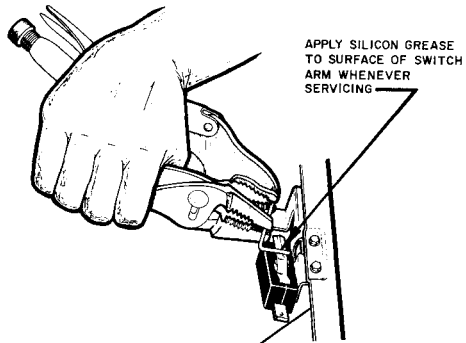
1. Using 1 - WH16X376 Actuator Bracket as a test gauge, will give the required values. Refer to Figure 7.
2. Place washer control in "on" position. Raise lid to stop machine.
3. Place bracket at position "A" and lower lid. Washer must start before bottom edge of lid contacts top of bracket.
4. Move bracket to position "B" and close lid. Slowly raise lid. Washer must stop before bracket can be slid inward under rubber lid bumper.

If the above limits cannot be met, adjust the switch actuator, as needed. Use vise grip pliers, as indicated in Figure 8, to prevent bending actuator brackets and make adjustment with common pliers, as shown. CAUTION: A 1/10" bend, as shown, will result in a 3/10" change at the lid when measured. Therefore, only a slight bend is required.

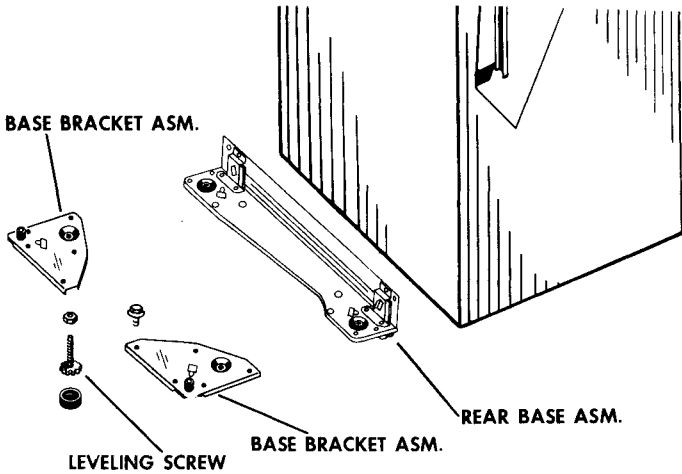
# CABINET CONSTRUCTION & SUSPENSION SYSTEM



**Figure 7—Measurements**



**Figure 8—Switch Actuator Adjustment**



**Figure 9 – Leveling**

## **LEVELING SYSTEM**

The rear base asm. provides self-leveling for the rear of the washer. The two front leveling legs are screw-in type.

## **SUSPENSION**

### **Description**

The suspension system consists of the transmission mounted on a steel channel frame. The motor and clutch assembly and the counterweight are also mounted on this frame, which in turn is hung on a plastic coated steel cable, which runs across three pulleys in the upper corners of the cabinet.

Figure 10 is an exploded view of the cabinet, suspension, dampening, systems.

# CABINET CONSTRUCTION & SUSPENSION SYSTEM

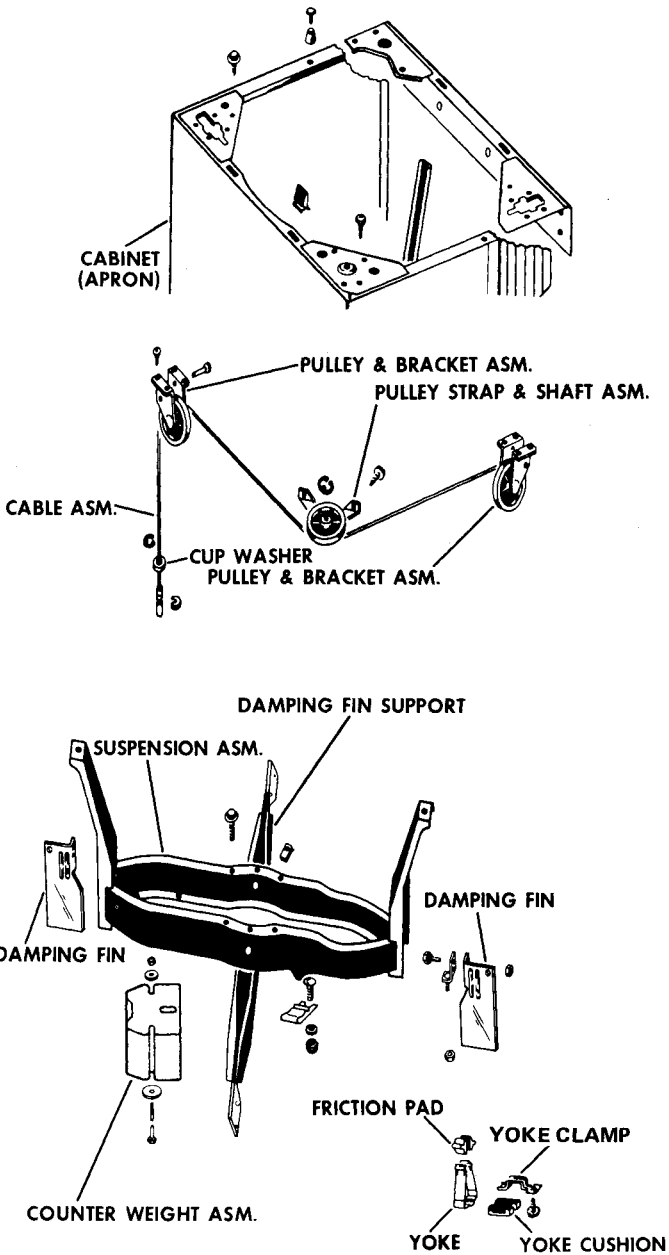


Figure 10—Suspension System

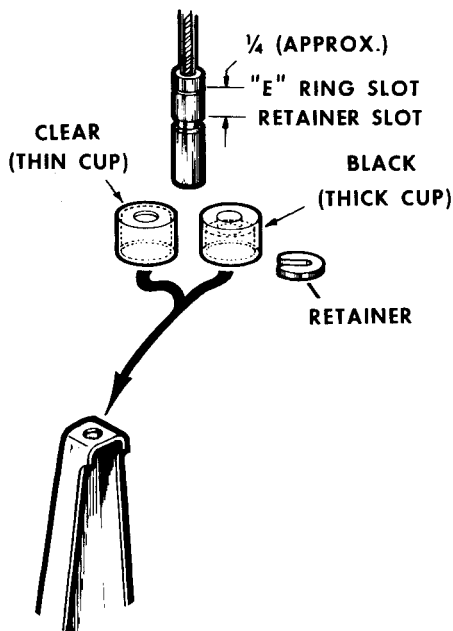
## **SUSPENSION CABLE**

### **Description**

The suspension cable and the two retainer cups are designed to allow for adjustment of the tub-to-basket-gap in the field. Too small a gap may cause excessive water retention and polka-dotting and increases the incidence of clothes over the side of the wash basket.

The principle of adjustment lies in the thickness of the retainer cups. Using one thick cup in place of one thin cup:

- a. Effectively shortens the cable by .160 inches.
- b. Increases the TUB-TO-BASKET-GAP by .080 inches.
- c. Decreases the BASKET-TO-COVER-SHIELD-GAP by .080 inches.



**Figure 11—Cable Adjustment**

The terminal cables are color coded as follows:

- Large Capacity - Red
- Standard Capacity - Natural (Silver)

Additional shortening may be obtained by using an automotive brake cable shortener. Place the cable shortener on the rear vertical leg of the cable. Be sure shortener does not come in contact with any other parts of the machine



## **CABINET CONSTRUCTION & SUSPENSION SYSTEM**

when basket is moved through its entire range of movement. Cable can be shortened until the basket clothes retainer comes within 1/4" of the plastic cover shield. This should be the best operating condition, refer to Tub-To-Basket-Gap in this tab section.

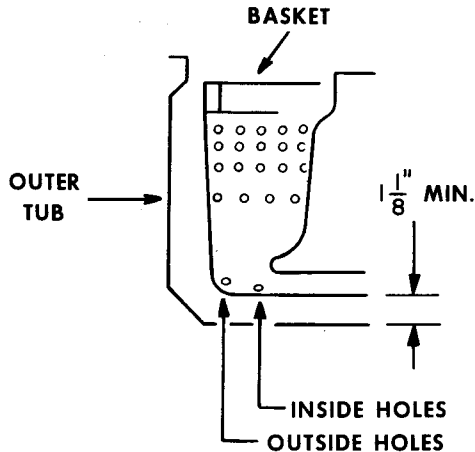
### **SUSPENSION CABLE REPLACEMENT**

1. Block up suspension assembly from the rear of the machine (only enough so that dampening fins do not come out of friction pads).
2. Reach in from rear of the machine and remove E ring from each end of cable. Remove cable.
3. Raise cover and remove plastic pin stops from each vertical pulley.
4. Start new cable down left front vertical pulley. Return to rear of machine and place cable through front suspension arm. Place cup washer and seat retainer on cable termination. (Apply grease in cup washer. This will prevent the seat retainer from falling out).
5. Remove guide screws from right front horizontal pulley, place cable around pulley and apply tension to cable, replace guide screws.
6. Continue with cable over and down rear vertical pulley and through the suspension arm, replace cup washer and seat retainer.
7. Remove blocks from under suspension (cable should be tight). Now replace E rings.
8. Rock suspension back and forth with agitator and observe pulleys for movement and proper assembly of cable in pulley grooves.

### **TUB-TO-BASKET-GAP**

The tub-to-basket gap is controlled by the suspension cable and should not be less than 1-1/8" as shown. Center the agitator in the cover opening and measure the gap with a nail, ice pick, or other small device by inserting it through the bottom holes of the basket. Take measurements at 3, 6, & 9 O'Clock when facing the washer and average the results.

## CABINET CONSTRUCTION & SUSPENSION SYSTEM



**Figure 12—Basket to Tub Measurement**

A major cause of improper tub-to-basket-gap are bent apron corner brackets. If the machine has been transported without the crate bottom and support packing, the top corner apron brackets which hold the suspension cable pulleys could be bent, if the machine had been dropped during handling. In this case, additional shortening may be obtained by using an automotive brake cable shortener. Place the cable shortener on the rear vertical leg of the cable. Be sure shortener does not come in contact with any other parts of the machine when basket is moved through its entire range of movement. Cable can be shortened until the basket clothes retainer comes within  $1/4''$  of the plastic cover shield. This should be the best operating condition.

### **AUTOMATIC WASHER FIELD CHECK FOR MACHINE WALKING, BASKET STRIKE, AND EXCESSIVE VIBRATION**

These three problems are related to each other because:

1. A customer complaint may not give a true indication of the real problem. A customer may say a machine is walking when the real problem is basket striking or he may say a machine has excessive vibration, when the problem is walking.
2. Some problems may cause either one, two or all three of the above complaints.
3. When a machine has basket striking or excessive vibration, the machine may walk. When a machine walks, it will appear to have excessive vibration.

Therefore, check a machine by the specifications listed under each area of the procedure regardless of the customer complaint.

# CABINET CONSTRUCTION & SUSPENSION SYSTEM

First, determine the Heavy Quadrant in the basket.

Open the cover assembly of the machine and tape the lid switch actuator arm down so that the machine will spin with the lid open. Replace the cover, remove the filter pan, and put the machine in spin. After the machine has reached terminal speed, place the point of a lead pencil lightly against the filter mount near the top of agitator. As the basket spins, only one point of the filter mount will touch the pencil due to inherent unbalance in the basket.

Turn the machine off. Note the mark on the filter mount. The "Heavy Quadrant" is located by drawing an imaginary line from the mark through the center of the agitator to the other side of the basket wall. Mark that point with a small piece of tape or other means so that its location is always known. Do not use the agitator as a reference point because the agitator moves with respect to the basket. After the "Heavy Quadrant" is found, remove the tape from the lid switch.

## **Equipment Needed:**

1. Assorted shot bags.
2. Small level
3. Tape
4. Pencil
5. Paper
6. 6" Scale

## **Procedure:**

1. Complaint of Machine Walking
  - A. Specification—The machine should not walk with the maximum unbalance (shot bag) that the basket will carry in spin without the basket striking the tub.
  - B. Determine if machine walks — By trial and error, find the heaviest shot bag that can be placed at the Heavy Quadrant (as determined above)— and still not have the basket strike. Now allow machine to spin at terminal speed for a few minutes to check for machine walking. If machine does walk, use Check Chart to determine cause and perform suitable remedy.
2. Complaint of Basket Striking
  - A. Specification—The basket should not strike the tub with less than 3-1/4 lbs. unbalance in the basket bottom at the "Heavy Quadrant".

## CABINET CONSTRUCTION & SUSPENSION SYSTEM

- B. Determine if the basket strikes — place a 3-1/4 lb. shot bag in the bottom of the basket at the “Heavy Quadrant”. Turn on machine and spin basket up to terminal speed (600 RPM). If basket does not strike, it is within specification. If basket does strike, use Check Chart to determine cause and perform suitable remedy.

Too much inherent unbalance in the basket can be determined and corrected by the following procedure:

1. Find the minimum weight shot bag, placed at the H.Q., that will cause basket to strike.
2. Find the minimum weight shot bag, placed opposite (180°) the H.Q., that will cause basket to strike.
3. If difference is greater than one (1) lb., then remove 3 basket bolts and rotate basket 120° and recheck for unbalance difference. It may be necessary to repeat this step because there are 3 possible basket positions.
4. If these steps do not make the basket meet these specifications, then replace the basket.

### 3. Complaint of Excessive Vibration

- A. Specification—The motion of the machine cabinet should not exceed 1/16” in any direction, at terminal spin speed, with a 2-1/2 lb. unbalance in the basket bottom at the “Heavy Quadrant”. The motion of the machine backsplash should not exceed 3/32” in any direction at terminal spin speed with a 2-1/2 lb. unbalance in the basket bottom at the “Heavy Quadrant”.
- B. Determine if the machine has excessive vibration. Place a 2-1/2 lb. unbalance in the basket bottom at the “Heavy Quadrant”. Tape a small piece of paper on top of the machine cover and also on top of the backsplash. When the machine reaches terminal spin speed, hold a pencil point light against the paper while slowly moving the pencil at right angles to the machine vibration motion. By measuring the band width of the pencil mark on the paper, a good indication of the vibration amplitude can be obtained. If the pencil is held tightly against the paper, the point will move with the machine and give an erroneous measurement.
- C. If any of the specifications in Item A are exceeded, use Check Chart to determine cause and perform suitable remedy.

# CABINET CONSTRUCTION & SUSPENSION SYSTEM

## CHECK CHART

COMPLAINT			POSSIBLE CAUSES
WALKING	BASKET STRIKE	EXCESSIVE VIBRATION	
X			Leveling Foot Pads Missing
X			Dirt Under Leveling Feet
X			Leveling Legs Missing
X			Jam Nuts Loose or Missing
X		X	Machine Not Level
X			Self Level Strap Sticking
X			Leveling Legs Extended Too Far
X			Leveling Legs Threads Stripped
X			Crn Bkt Weld Nut Bkn Lse Or Nut Stripped
X	X		Unbalanced Load
X			Basket Striking
X			Excessive Vibration
	X		Dampening Forces Too Low Friction Pads Missing Yoke Clamp Broken Or Loose Yoke Force Too Low
		X	Dampening Forces Too High Oil on Pads Yoke Force Too High
		X	Loose Base Hardware
		X	Tight Suspension Pulley
	X		Basket Out of Spec. (See Text)
		X	High Mechanism Boot Gradient
		X	Backsplash Mounting Screws Loose

**INDEX**

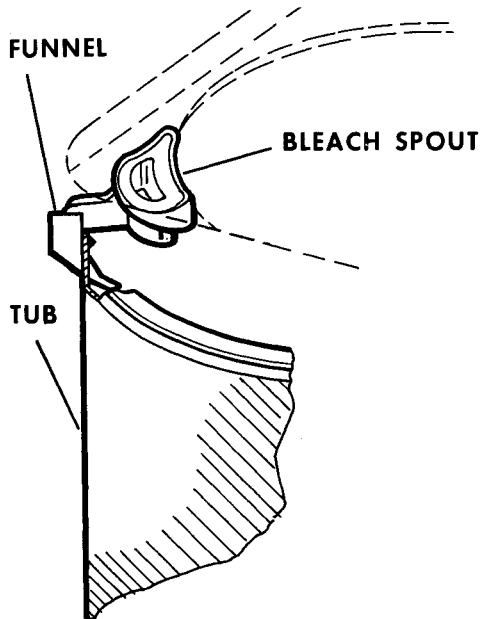
	<b>PAGE</b>
Bleach Dispenser	F - 2
Dispensall™ System	F - 6
Mini-Wash/Quick® - GE	F - 2
Rapid Wash System - Hotpoint	F - 4
Rinse Agent Dispenser	F - 5

## OTHER COMPONENTS

### BLEACH DISPENSER

#### Description

The spout for this one shot bleach dispenser is a snap fit into the washer cover. A bleach funnel is attached to the inside of the outer tub just below the spout. A correct measure of bleach is poured into the spout during or after the Wash fill period. It flows down the spout, into the funnel and is directed into the wash water between the tub and the basket, see Figure 1.

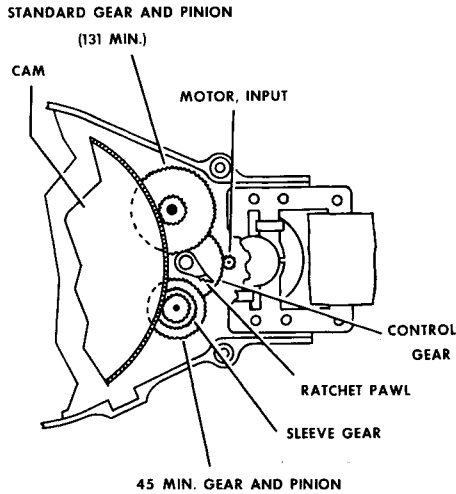


**Figure 1**

#### **MINI-WASH® SYSTEM-MINI-QUICK FEATURE — GE (CLAM SHELL TIMER)**

The Mini-Quick function is obtained by a very low water level and the use of the Mini-Basket™ tub and filter. Water enters the large wash basket and when the Mini-Wash level is reached, the water is brought up to the Mini-Basket by the recirculation pump. Temperature and speeds should be set per user instruction sheet.

The Mini-Quick function is obtained by using 2-gear and pinion assemblies in the timer. A 45 minute gear assembly is used, along with a 131 minute NORMAL gear and pinion, refer to Figure 2. Between these two gear assemblies is a ratchet pawl mounted on the control gear shaft.



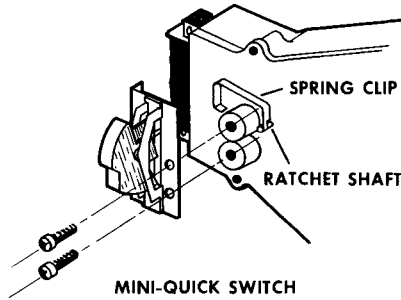
**Figure 2**

Both gear and pinion assemblies have a slip clutch mechanism which allows the cam-driving pinion to slip in one direction. When the ratchet pawl is in the Neutral (disengaged) position, the timer motor drives both assemblies. The 45 minute pinion rotates three times faster than the NORMAL pinion, so the NORMAL pinion is overridden and slips, and the cam is driven at three times NORMAL speed. This gives MINI-QUICK cycle.

For NORMAL operation, the pawl engages the sleeve gear which traps the 45 minute gear assembly clutch and prevents it from gripping the shaft. No torque is transferred to the 45 minute cam-driving pinion, so the cam is driven only by the NORMAL cam gear. The pawl is engaged and disengaged through a rocker button mounted on the timer, refer to Figure 3. In the MINI-QUICK setting, the pawl is rotated away from the sleeve gear which allows the 45 minute gear assembly to drive the cam at three times NORMAL speed.



# OTHER COMPONENTS



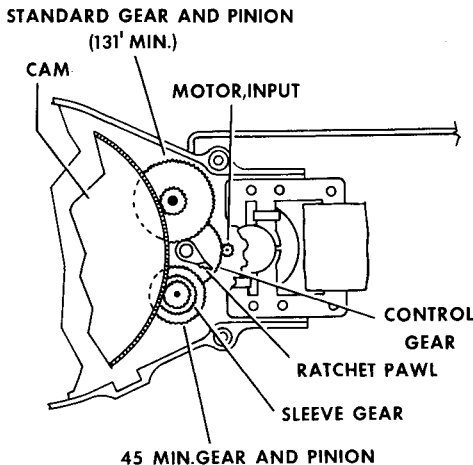
**Figure 3**

## Service Hints

1. Because of the larger diameter shaft required for MINI-QUICK, a plastic insert is provided in the front housing on NON-MINI-QUICK models. The insert must be removed from replacement front housings when used on MINI-QUICK timers.
2. The "V" notch on the bottom of the rocker button must embrace the end of the spring clip before tightening the two mounting screws.

## RAPID WASH SYSTEM — HOTPOINT (CLAM SHELL TIMER)

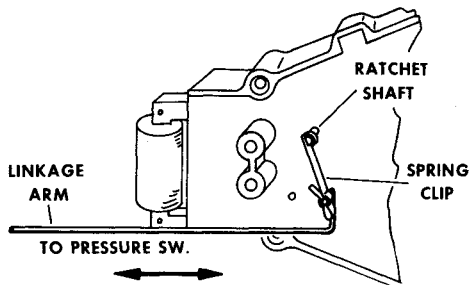
The RAPID WASH function is obtained by using 2-gear and pinion assemblies in the timer. A 45 minute gear assembly is used, along with a 131 minute NORMAL gear and pinion, refer to Figure 4. Between these two gear assemblies is a ratchet pawl mounted on the control gear shaft.



**Figure 4**

Both gear and pinion assemblies have a slip clutch mechanism which allows the cam-driving pinion to slip in one direction. When the ratchet pawl is in the Neutral (disengaged) position, the timer motor drives both assemblies. The 45 minute pinion rotates 3 times faster than the NORMAL pinion, so the NORMAL pinion is overridden and slips, and the cam is driven at 3 times NORMAL speed. This gives RAPID WASH.

For NORMAL operation, the pawl engages the sleeve gear which traps the 45 minute gear assembly clutch and prevents it from gripping the shaft. No torque is transferred to the 45 minute cam-driving pinion, so the cam is driven only by the NORMAL cam gear. The pawl is engaged and disengaged through a mechanical linkage to the Water Level Switch, refer to Figure 5. The linkage is spring-loaded at the WLS to insure positive engagement of the pawl and sleeve gear in all WLS positions except RAPID WASH. In the RAPID WASH setting, the pawl is rotated away from the sleeve gear which allows the 45 minute gear assembly to drive the cam at 3 times NORMAL speed.



**Figure 5**

### Service Hints

1. Take care when closing up the backsplash after servicing, to prevent the harness from dislodging the linkage arm.
2. Set WLS to RAPID WASH before closing the backsplash.
3. Because of the larger diameter shaft required for RAPID WASH, a plastic insert is provided in the front housing on NON-RAPID WASH models. The insert must be removed from replacement front housings when used on RAPID WASH timers.

### RINSE AGENT DISPENSER

#### Operation

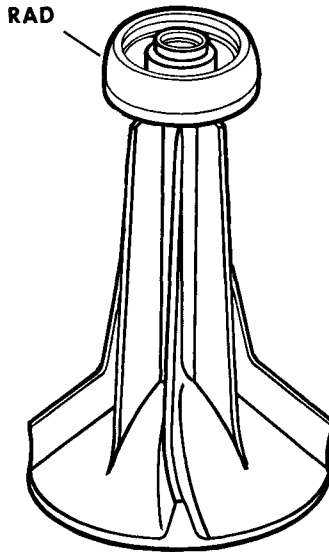
The diluted rinse agent/fabric softener is poured into the center cavity of the agitator mounted dispenser. Refer to User Instructions for correct amount and proper dilution.

## OTHER COMPONENTS

The solution remains in the center cavity during Wash agitation and is moved into outer cavity during Wash Spin. At the end of Spin, the solution flows down into the wash basket for the deep Rinse period. The dispenser can readily be removed from the agitator when not in use.

### Service

Agitator mounted RAD which has become clogged because of the interaction between the detergents and fabric softeners can be cleaned by immersing it in a solution of 50% rubbing alcohol and 50% warm water for 15 minutes. It may take more than one soaking for complete cleansing.

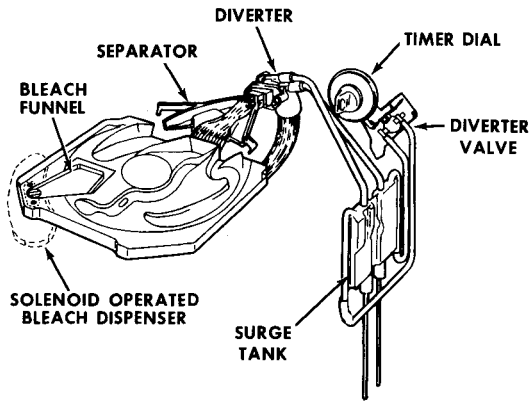


**Figure 6    TM**  
**DISPENSALL SYSTEM**

### Description

The Dispensall system is a lid mounted automatic system for dispensing powdered Soak or Pre-Wash detergent, powdered Wash detergent, liquid bleach, and liquid fabric softener each in the proper portion of the cycle. The bleach and fabric softener may be used full strength without the need to dilute. The Dispensall tank assembly, which is shipped in a separate carton on top of the machine, has three cavities for the washing additives. It also has two troughs through which recirculation water is routed to these cavities. The fourth cavity, RIGHT REAR, opens directly into the filter pan below.

Figure 7 is a see-thru view showing the location of the major components.



**Figure 7**

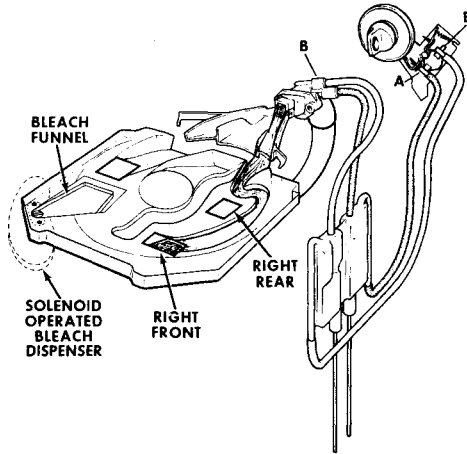
### Operation

The recirculation water flows through the diverter and into the tank assembly. This water flow through the diverter causes air to flow through the hoses, surge tank and diverter valve. This air controls the direction of the water. The diverter valve is controlled by a cam on the rear of the timer dial. The cam actuates the diverter valve to close either one or neither of the A and B hoses (Figure 8).

During PRE-WASH or SOAK agitation, neither hose is closed by the diverter valve and the water flows through the center of the separator, and directly into the filter, refer to Figure 7.

During WASH agitation, the "A" diverter valve hose is closed by the timer dial cam. Air still flows through the "B" system and cushions the water on the left side forcing the water to flow to the right into the RIGHT FRONT tank and down through the filter, refer to Figure 8.

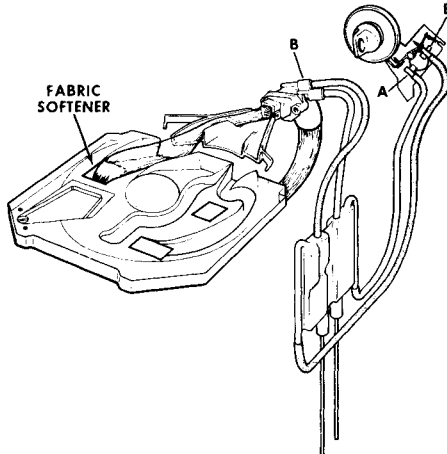
# OTHER COMPONENTS



**Figure 8**

**NOTE:** The instructions say to put the WASH ONLY detergent into the RIGHT REAR cavity. The detergent will fall directly into the filter pan. The water flows through the RIGHT FRONT cavity and through the filter, where it dissolves the detergent.

During RINSE agitation the "B" diverter valve hose is closed by the timer dial cam.



**Figure 9**

Air still flows through the "A" system and cushions the water on the right side, forcing the water to flow to the left into the FABRIC SOFTENER tank and down through the filter. The FABRIC SOFTENER cavity has a syphon tube which drains it at the end of its respective cycle, refer to Figure 9.

### Service

**Tank Assembly:** Be sure that the tank has been properly installed, per the enclosed instructions. The syphon tubes in the FABRIC SOFTENER cavity may become plugged with laundry products or lint. Remove the tank and flush with fresh water. If the syphon tube is defective or improperly positioned, replace the tank assembly.

**Separator:** The rear of the separator is attached to the diverter by snapping it over two plastic studs. The diverter front has two plastic ears that snap into two holes in the cover shield.

**CAUTION:** Whenever the washer cover is to be raised, the separator must first be disengaged from the cover shield to prevent breakage.

**Diverter:** The diverter is attached to the outer tub by two screws with nylon seal washers and a square rubber gasket. To remove the diverter, it will be necessary to remove the left rear, right rear and right front (all but the left front) tub mounting screws and raise the right rear portion of the tub about one inch to obtain sufficient clearance. After the diverter is removed from the tub, the recirculation hose clamp may be released and the recirculation and air hoses removed. Upon reassembly, be sure the rubber gasket is positioned properly and the mounting screw seal washers are in place.

**Surge Tanks:** The surge tanks are mounted to the cabinet corner bracket with a single screw. Upper air hoses should be positioned to eliminate kinking and the lower overflow hoses positioned away from moving parts, such as the flexible pump coupling.

**Diverter Valve:** The diverter valve and bracket assembly is mounted with two screws. One of these screws is a timer mounting screw. It will be necessary to first remove the timer and then the diverter valve assembly.

**CAUTION:** To prevent damage to the diverter valve actuator arm as the timer is removed, depress the actuator arm, extending its return spring. This will provide sufficient clearance between the arm and the timer dial.

**System Diagnosis:** Malfunctions in the Dispensall system may be grouped into two general categories: (1) improper air control and (2) diverter or tank contamination.

Improper air control may be caused by:

- a) Diverter valve malfunction (bent actuator arm or poor valve seal).

## OTHER COMPONENTS

b) Kinked air lines or air leaks.

To test the air control system, fill the washer and start agitation. Raise the washer cover and, with your hand, pinch the right hand air hose at the diverter. The water stream should deflect to the right. Pinch the left air hose at the diverter. The water stream should deflect left. If this action is observed, check all air lines, surge tanks and the diverter valve for kinks, loose connections or leaks.

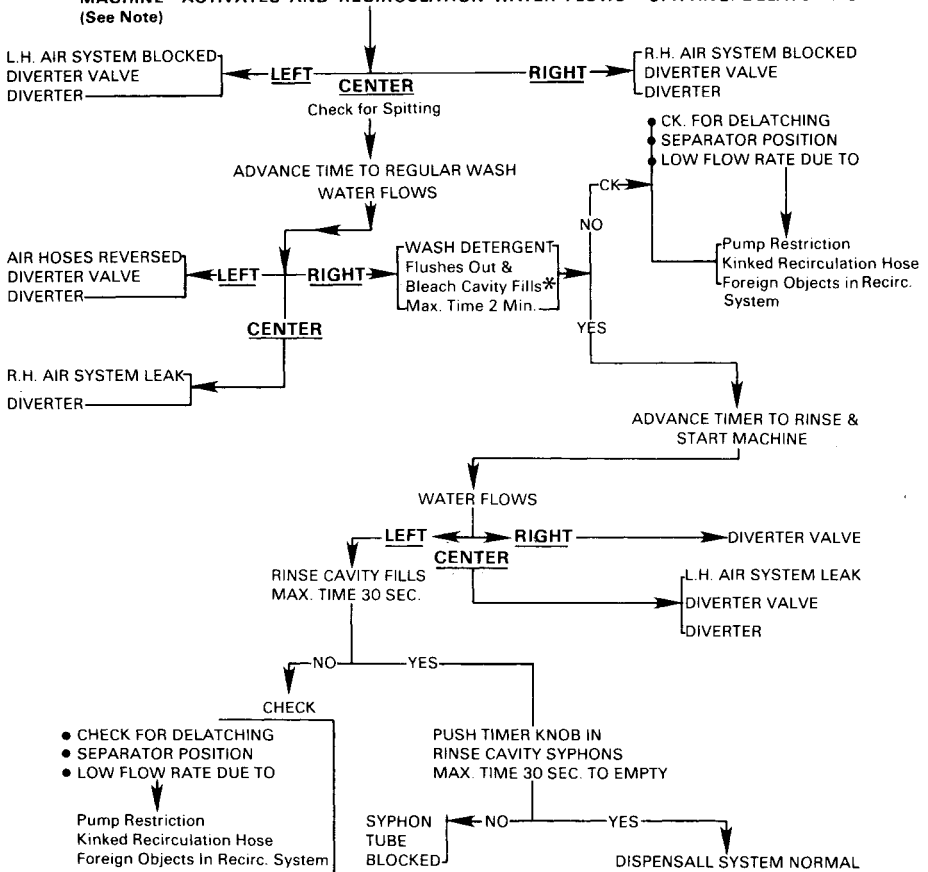
If the water stream deflects right and left but not far enough to enter the separator properly, you may suspect reduced recirculation rate as a result of pump obstructions, hose kinking or lint build-up within the pump itself.

**Diverter Contamination:** Lint accumulation or build-up of calcium carbonate in the diverter can result in improper or erratic operation. If pinching the air hoses at the diverter does not produce the desired results, check the diverter for lint or carbonate build-up. Cleaning should be done by fresh water flushing or cleaning with a small brush. **DO NOT** clean with a knife or screwdriver, as any scratches on the inside surface of the diverter will adversely affect its performance due to unwanted turbulence, and the resultant rough surface will tend to collect additional lint or build-up of calcium carbonate.

## DISPENSALL CHECKOUT PROCEDURE

1. SET MACHINE CONTROLS: Timer-SOAK, Water Level-HIGH, Wash/Rinse Temp.-WARM, Speed-NORM.
2. REMOVE DISPENSALL TANK AND CHECK THE FOLLOWING:  
Tank drained and free of lint.  
Separator secured to cover shield and diverter.  
Remove any lint from separator and diverter.
3. REINSTALL TANK - be sure tabs are properly seated.
4. CLOSE LID AND START MACHINE.
5. OPEN SMALL DISPENSALL LID AND OBSERVE RECIRCULATION WATER FLOW. (Follow the check chart below).

**MACHINE ACTIVATES AND RECIRCULATION WATER FLOWS— SPITTING/DELATCHING**  
(See Note)



### NOTE:

**SPITTING** - When the normal flow is CENTER (for SOAK Or EXTRA RINSE) SPITTING is small amounts of water being shifted either Left or Right. SPITTING during SOAK or EXTRA RINSE may be tolerated if water DOES NOT FLUSH DRY DETERGENT OUT. WATER MUST NOT ENTER RINSE AGENT CAVITY.

**DELATCHING** - When the normal flow is either LEFT or RIGHT, delatching is the intermittent shifting of flow back to the center position.

Spitting or delatching during the first few seconds of Recirculation Flow may be noted but should stabilize in the correct position.

Persistent spitting or delatching is caused by lint or foreign objects in the diverter or a defective diverter. These faults are also intermittent and affected by water temperature & water level — observe water flow for 2 to 3 minutes to identify these possible problems.





# SAFE INSTALLATION & SERVICE PRACTICES

## General

Set forth below are some general principles which should be followed by persons performing installation and/or service on the automatic washer. This listing is not all inclusive, and is only intended to serve as a general guide. It is no substitute for common sense and safe working habits, which should be exercised by everyone who is qualified to service appliances.

## SAFE INSTALLATION

### 1. Overfusing

Overfusing of an appliance is due to ignorance and/or carelessness and, in the case of an automatic washer, can create an extremely unsafe and unwarranted condition. Service technicians discovering situations where circuits are overfused should point out the potential fire hazard to the customer. The washer should be operated on a separate circuit fused with a 15 or 20 amp time-delay fuse or circuit breaker. No other electrical device should be operated on the circuit when the washer is running.

### 2. Grounding

All washers are manufactured and supplied with provisions for proper grounding. The installation instructions supplied with each washer maintain that:

- a. The line cord should be plugged into a properly grounded, three-prong receptacle having the proper electrical rating. See rating plate.
- b. Where a two-prong receptacle is encountered, it is the personal responsibility of the customer to have it replaced with a properly grounded three-prong outlet.

**DO NOT, UNDER ANY CIRCUMSTANCES, CUT OR REMOVE THE THIRD (GROUND) PRONG FROM THE POWER CORD PLUG.**

- c. In addition to making sure the washer is grounded through the power cord, an external ground wire (not supplied) may be firmly attached to the washer cabinet and a metal cold water pipe.

The customer should be advised of any installation condition which might prevent the washer from being properly grounded, i.e., house wiring not grounded, plastic water piping, etc.

Grounding should never be removed unless necessary for servicing, and must always be replaced before the service call is completed.

## **SAFE INSTALLATION & SERVICE PRACTICES**

### **3. Apron-Back Panel**

If removed during installation, the fibre-board apron back must always be replaced before the call is completed. The apron back not only serves to shield electrical connections and moving parts from the reach of children, but also reduces the accumulation of dirt and dust, which increases the friction and wear on moving parts.

### **4. Leveling**

The washer should be properly leveled to insure that it remains stationary during operation at all times. Mis-leveling may allow the washer to "walk" with unbalanced loads during spin, thus creating a potential safety hazard by putting strain on the power cord and intake hoses.

## **INSTALLATION REQUIREMENTS**

### **General**

- 1. LOCAL CODES** — The installation must be made in accordance with local codes and ordinance requirements. Provision of proper plumbing and electrical facilities is the responsibility of the owner.
- 2. WATER SUPPLY LINES** — Both hot and cold supply lines must be thoroughly flushed prior to installation. This is especially important with new construction. Each line should be opened full on and run for one full minute into drain.
- 3. LOCATION** — Washer must be installed on firm flooring to minimize vibration during spin cycles. Concrete flooring is best, but wood base flooring is sufficient, providing floor support meets minimum FHA standards. Washer should not be installed on rugs or thick carpets.

Do not install washer in location where temperature may be below freezing. Be sure to drain all water from washer before exposing to freezing temperatures, such as when moving.

### **Electrical**

Each washer is to be supplied by a separate circuit of proper voltage fused with a 15 or 20 Ampere time-delay fuse or circuit breaker, and terminated in a properly grounded three-prong wall receptacle (see Grounding). No other electrical device should be operated on the same circuit when the washer is operating.

# SAFE INSTALLATION & SERVICE PRACTICES

## Grounding

**IMPORTANT — PLEASE READ CAREFULLY!**

**FOR PERSONAL SAFETY, THIS APPLIANCE MUST BE PROPERLY GROUNDED**

The power cord on this appliance is equipped with a three-prong (grounding) plug which mates with a standard three-prong (grounding) wall receptacle.

Where a standard two-prong wall receptacle is encountered, it is the personal responsibility and obligation of the customer to have it replaced with a properly grounded three-prong wall receptacle.

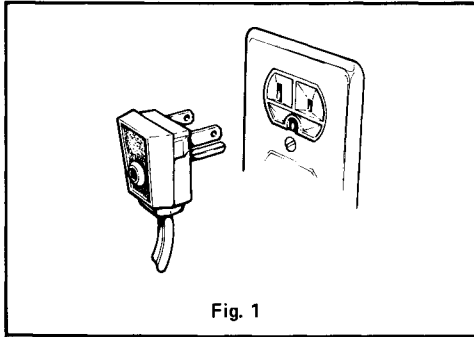


Fig. 1

**DO NOT, UNDER ANY CIRCUMSTANCES, CUT OR REMOVE THE THIRD (GROUND) PRONG FROM THE POWER CORD PLUG.**

# SAFE INSTALLATION & SERVICE PRACTICES

## Plumbing

1. **WATER PRESSURE** — Must be 10 p.s.i. minimum to 150 p.s.i. maximum static pressure measured at faucet.
2. **WATER TEMPERATURE** — Hot water heater should be set to deliver 140° to 150°F. water IN THE WASHER, when hot wash is selected. However, water temperature must not be over 180°F.
3. **SHUT-OFF VALVES** — Both hot and cold shut-off valves (faucets) should be supplied.

## Drain System

1. The washer drain hose should be positioned in a 1-1/2" minimum I.D. standpipe or a drain tub. The standpipe or top of drain tub should be a minimum of 30" to a maximum of 8 feet, above the base of the washer. If standpipe or drain tub is too low, and the washer is stopped in agitation, a syphoning action can be started which will cause the water to drain out of the machine prematurely.
2. The washer drain must not be solidly connected to the house plumbing. If drain is plumbed in solid without an air break, the following may occur:
  - a. Sewer water may be pumped into the washer during the agitation period.
  - b. A syphon may be set up which could prematurely empty the water from the water.

## Suds Save Machine

### Set Tub Requirements

1. 22 gallons minimum capacity.
2. Bottom 15" minimum above floor.
3. Top edge 33" minimum and 36" maximum above floor.

## INSTALLATION HINTS

### 1. Transporting

To prevent damage to the suspension system, the wooden crate bottom should remain attached to the bottom of the machine until the final installation site is reached.

### 2. Leveling

The washer should be leveled with the base as close to the floor as possible. The rear legs are self-leveling. Only the two front leveling feet require adjustment.

### 3. Inlet Hoses

The two inlet hoses furnished with the washer are four feet in length. A special 8 foot long Inlet Hose (WH41X82) is available.

On those models which have the intake ports of the water valve pointing straight back, a potential problem is that the machine cannot be pushed back flush against the wall. If it is too tight against the wall, the intake hoses will kink. Intake hose, WL29X76, with the 90° elbow at the coupling, should resolve this complaint.

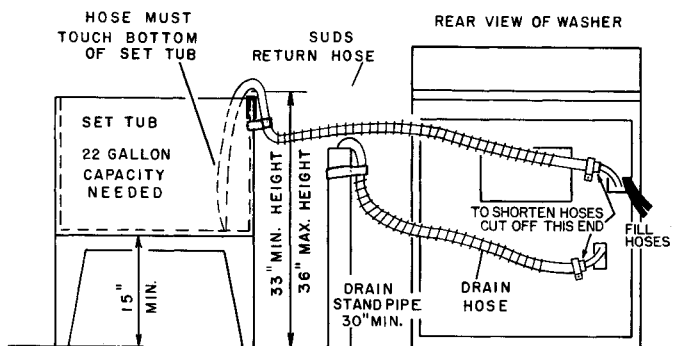
### 4. Drain Hoses

**NON-SUDS SAVE MACHINES** — The plastic drain hose extends approximately 30" beyond the back of the washer (not including nozzle). To lengthen drain hose, the following parts may be obtained:

Limit total length of hose (outside of machine) to 10 feet.

Drain hoses must be secured to standpipe or set tub.

Parts	or	Kit
Hose (80" Long)	WH41X184	WH49X177 With 43" Long Hose
Adaptor	WH41X156	
Clamp	WH1X2036	



**Figure 3 — Typical Suds Save Installation**

# SAFE INSTALLATION & SERVICE PRACTICES

## Suds Save Machines

- a. The suds save hose must be installed with a minimum of sag, Figure 3. Excessive sag may cause the hose to become air locked and prevent the return of saved water.
- b. If necessary, cut end of suds return hose to fit set tub, as shown. End of hose must be cut on diagonal.

c. CAUTION:

- Be sure drain hose is taped or secured to standpipe or other drain facility.
- Be sure suds return hose is secured to set tub.

TO LENGTHEN THE DRAIN HOSE, if needed, procure the following parts from your distributor. Attach WH41X96 3' hose or WH41X112 10' hose to washer drain hose using a WH1X1727 hose connector and two WH1X2026 clamps. LIMIT TOTAL LENGTH OF DRAIN HOSE TO 10 FEET.

## SAFE SERVICE

### Safety Devices

#### Product Safety Devices

Safety devices engineered into the product must never be removed, by-passed or altered in such a manner as to defeat or hinder the purpose for which they were intended. Examples of such devices used on the washer are —

#### 1. Lid Switch

The lid switch is provided to prevent the washer from spinning or agitating while the lid is raised. Servicing aids (shunts, blocks or any other type of by-pass device) must be removed before the service call is complete.

#### 2. Inlet Air Break

All washers are provided with an inlet air break, incorporated into the plastic water inlet (located between the water valve and the inlet nozzle). This air-break prevents the flow of wash water back into the supply system in the event of flooding. The inlet air break must never be removed or obstructed in such a manner as to defeat its intended purpose.

#### 3. Overflow tube

All washers are equipped with an overflow nozzle and tube, located in the left front corner near the top of the outer tub, and extending down to the left front lower corner. The purpose of the overflow is to allow flooding

## SAFE INSTALLATION & SERVICE PRACTICES

water to escape onto the floor instead of out through the top where it could seep into the control housing and create an unsafe condition. The overflow must never be plugged or altered in such a manner as to defeat its intended purpose.

### 4. Shields

In the interest of product safety, all shields around electrical components must be reinstalled. WH16X317 is standard shield material which can be cut to shape, using the old part as a pattern, when the old part is not reusable.

## SAFE SERVICE PRACTICES

### 1. Removing Power

All power should be removed from the washer, if electrical or other service is to be performed that will involve contact or near contact with electric wires. Sometimes it is necessary to make checks with the power on; in such instances, extreme caution should be used to prevent shock. Watch out for the customer's children!

### 2. Use of Proper Tools

Always use the correct tool for the job, and always use a tool that is in good condition. Worn wrenches and screwdrivers, faulty ratchets, rounded sockets, etc., are all causes of accidents. Be especially cautious when dismantling components in the motor-suspension area of the washer. Burrs and sharp edges on sheet-metal parts can cause severe cuts, if the technician is careless.

### 3. Hoses

Before returning the washer to service, be sure that all hoses are properly connected. There must be no undue stress on any hose. All hoses must be free of any kinks and must not be pinched between any of the machine or facilities components. Be especially careful of the pressure switch hose. Hose must be routed to insure clearance from moving parts in the machine, sharp edges, and normal customer traffic patterns.

## MACHINE SPECIFICATIONS

### Machine Rating

1/3 H.P. Models — 7.0 Amps @ 115 V.

1/2 H.P. Models — 8.5 Amps @ 115 V.

1/3 H.P. Models — 4.0 Amps @ 230 V.

Unrated Models — 8.0 Amps @ 115V.



# SAFE INSTALLATION & SERVICE PRACTICES

## Power Consumption

For an average machine with a 1/3 H.P. or unrated motor at 115V., 10.6 inches of water.

FUNCTION	NO CLOTHES* LOAD — WATTS	WITH CLOTHES* LOAD — WATTS
Agitation	450	480
Start Spin 2-Min.	800	800
Free Spin	400	420

Power consumption per cycle for an average machine with 10 minute wash time, is approximately 0.20 KWH.

For an average 1/2 H.P. machine at 115 V.,

FUNCTION	WITH 12 LB.* CLOTHES LOAD - WATTS
Agitation	600
Start Spin 2 - Min.	700
Free Spin	550

Power consumption per cycle for an average machine with 10 minute wash time, is approximately 0.25 KWH.

\* Add 40 watts each for Slow Speed Solenoid and Distribution Valve Solenoid, if energized.

## WATER FILL RATE (for a typical water valve)

WATER INPUT P.S.I.	GAL./MIN. ONE SIDE	GAL./MIN. BOTH SIDES
20	3.7	4.5
30	4.6	5.5
40	5.3	6.2
50	5.6	6.3
60	5.8	6.7
80	6.6	7.0
100	7.0	7.2
120	7.2	7.4
140	7.0	7.3
160	6.8	7.0

# SAFE INSTALLATION & SERVICE PRACTICES

## PUMP FLOW RATE — 60 HZ MODELS

Pump put rate — 17 gpm (at outlet of pump with no drain hose connected).

## AGITATION AND SPIN SPEEDS

<b>SPEEDS:</b>	<b>NORMAL</b>	<b>SLOW</b> <b>(2 SPEED MODELS ONLY)</b>
Agitation	100 osc./min.	70 osc./min.
Spin	600 ±10 RPM	420 ±10 RPM

---

## 60 TO 50 HERTZ CONVERSIONS

### See Notes A & B

Parts Required For Single Speed Models

### 120V To 120V

WH1X1904	Drive Belt
WH7X60	Primary Clutch Shoes (2)
WH5X181	Clutch Drum
WH12X313 (GE Timer)	Timer Rotor (See Note C)

### 1/3 HP MOTOR & UNRATED MOTOR CONVERSIONS

WH20X53	Motor (120V)
WH12X320	Motor Relay

### 1/2 HP MOTOR —

WH20X57	Motor (120V)
WH12X587	Motor Relay

---

### 120V To 220V

WH1X1904	Drive Belt
WH7X60	Primary Clutch Shoes (2)
WH5X181	Clutch Drum
WH12X313 (GE Timer)	Timer Rotor (See Note C)
WH13X63	Water Valve
WH12X312 (GE Timer)	Field & Coil Asm.

### 1/3 HP MOTOR & UNRATED MOTOR CONVERSIONS

WH20X54	Motor (220V)
WH12X277	Motor Relay

### 1/2 HP MOTOR —

WH20X58	Motor (220V)
WH12X588	Motor Relay

## SAFE INSTALLATION & SERVICE PRACTICES

Parts Required for TWO SPEED Models

### 120V To 120V

WH1X1904	Drive Belt
WH7X60	Primary Clutch Shoes (2)
WH7X63	Outer Lock-In Shoes (2)
WH5X182	Outer Clutch Drum
WH12X534	Speed Solenoid
WH12X313 (GE Timer)	Timer Rotor (See Note C)

### 1/3 HP MOTOR & UNRATED MOTOR CONVERSIONS

WH20X53	Motor (120V)
WH12X320	Motor Relay

### 1/2 HP MOTOR —

WH20X57	Motor (120V)
WH12X587	Motor Relay

---

### 120V To 220V

WH1X1904	Drive Belt
WH13X63	Water Valve
WH7X60	Primary Clutch Shoes (2)
WH7X63	Outer Lock-In Shoes (2)
WH5X182	Outer Clutch Drum
WH12X581	Speed Solenoid
WH12X313 (GE Timer)	Timer Rotor (See Note C)
WH12X312 (GE Timer)	Field & Coil Asm.

### 1/3 HP MOTOR & UNRATED MOTOR CONVERSIONS

WH20X54	Motor (220V)
WH12X277	Motor Relay

### 1/2 HP MOTOR —

WH20X58	Motor (220V)
WH12X588	Motor Relay

**Note A:** When ordering 50 Hertz Parts, always state on your order:  
"Required for conversion to 50 Hertz,       Volts."

**Note B:** For 220 Volt operation you may elect to convert to 120V only and then procure a step down transformer from local sources in foreign countries.

**Note C:** Optional part. If not used, timer will run at 5/6 speed and cycle times will be lengthened accordingly.

# SAFE INSTALLATION & SERVICE PRACTICES

## 50 TO 60 HERTZ CONVERSIONS

Before ordering parts, check owners for conversion parts kit which was available at time of purchase.

Parts Required for SINGLE SPEED Models —

### 120V To 120V

See Note D

WH5X174

WH1X2026

WH12X193 (GE Timer)

WH12X235

WH12X468

Clutch Shoes (2)

Clutch Drum

Motor Belt

Timer Rotor

Motor Relay - 1/3 HP

Motor Relay - 1/2 HP

### 220V To 120V

See Note D

WH5X174

WH1X2026

WH12X193 (GE Timer)

WH12X194 (GE Timer)

WH13X62

Clutch Shoes (2)

Clutch Drum

Motor Belt

Timer Rotor

Field and Coil Assembly

Complete Water Valve

### 1/3 HP — From 220V Only

WH20X64

WH12X235

Motor (120V)

Motor Relay

### 1/2 HP — From 220V Only

WH20X52

WH12X468

Motor (120V)

Motor Relay

Parts Required for TWO SPEED Models —

### 120V to 120V

See Note D

WH5X175

WH1X2026

WH12X193 (GE Timer)

WH12X235

WH12X468

Primary Clutch Shoes (2)

Outer Clutch Drum

Motor Belt

Timer Rotor

Motor Relay - 1/3 HP

Motor Relay - 1/2 HP

### 220V To 120V

See Note D

WH5X175

WH1X2026

WH12X193 (GE Timer)

WH13X62

WH12X194 (GE Timer)

Primary Clutch Shoes (2)

Outer Clutch Drum

Motor Belt

Timer Rotor

Complete Water Valve

Field & Coil Asm.

## SAFE INSTALLATION & SERVICE PRACTICES

### **1/3 HP- From 220V Only**

WH20X64

Motor (120V)

WH12X235

Motor Relay

### **1/2 HP- From 220V Only**

WH20X52

Motor (120V)

WH12X468

Motor Relay

**Note D: Remove extra weights plus clips and screws from both primary and outer lock-in shoes.**

## CUSTOMER – USER PRACTICES

### 1. PANELS

All panels and safety devices should be securely in place before operating washer in order to prevent electrical shock.

### 2. VOLATILE MATERIALS

- a. Do not add gasoline, degreasers, dry-cleaning solvents, or other combustible or explosive substances to the wash water. These substances may give off vapors that ignite or explode.
- b. Do not wash or dry articles that have been previously cleaned in, soaked in, or spotted with gasoline, degreasers, dry-cleaning solvents, or other combustible or explosive substances. These substances may give off vapors that could ignite or explode.

### 3. BLEACH/AMMONIA

Do not mix chlorine bleach with ammonia or acids such as vinegar an/or rust remover. Mixing can produce a toxic gas which may cause death.

## WASHABILITY

### How The Washer Cleans Clothes

Soil removal in an automatic washer is a combination of chemical and mechanical processes.

1. Chemical action – the detergent solution dissolves and loosens the soil in the fabric.
2. Mechanical action – soil is removed by flexing the clothes, and forcing the detergent solution through the fabric.

The functioning of the washer is aided by hot, soft, water, which increases the chemical action of the detergent used.

### Washing Recipe

1. The water must be hot and clean. The hot water temperature, measured in the basket, must be 140 - 150°F. Water that contains silt, iron, vegetation, etc.,

# USE & CARE WASHABILITY

WASHABILITY SYMPTOM – CORRECTION CHART

Symptom	Cause	Ways to Restore Sample	Long-Term Correction
Yellowing - in specific areas - such as middle of pillow case or body-resting area of sheet.	Poor body soil removal.	Responds well to 1 or 2 hot washes with proper amount of detergent and use of chlorine bleach.	Increase amount of detergent, use 150 F. wash water and increase the frequency of bleaching.
Yellowing - same shade over entire garment.	Clothes dried in dryer or combination after being washed in water treated by a mechanical water softener.	Responds well to chlorine.	Decrease amount of detergent used. Increase frequency of bleaching. NOTE: DO NOT decrease detergent to point where you get poor soil removal. Customer will have to add just this.
Yellowing - coloring more severe in areas of body soiling, but all areas are affected.	Hard water.	Strip with a non-precipitating water softener.	Increase amount of detergent used, and use a water softener such as Calgon, New Oakit, or Tex.
Yellowing - synthetics discolored due to oil pick-up.	Body oil and/or dye pick-up by nylon, dacron and other synthetics.	Pre-treat paste made of detergent customer is using, or a heavy duty liquid detergent, such as liquid All, Dynamo, Wisk, or Gain.	Pre-treat soiled areas with paste made of detergent and water. Use same detergent for pre-treating that is used for washing.
Yellowing.	Minerals - iron and manganese in water supply.	Responds well to dye remover, such as Rit or Tintex.	Water conditioning apparatus should be installed or use more non-precipitating water softener to remove the iron from the water. Drain hot water tank more frequently. Use no chlorine-type bleaches.
Yellowing.	Water supply colored by decayed vegetation.	Responds to bleaching.	Increase amount of detergent and bleach more often.

## USE & CARE WASHABILITY

will reduce the washing efficiency of the machine.

### Washing Products

1. The major detergent manufacturers base their package recommendations on 5-7 grain hardness water, average load size and average soiling conditions.
2. TABLETS OR LIQUID DETERGENTS — Follow the package instructions for 5-7 grain hardness water. Do not decrease the minimum recommended amount for softer water unless excessive sudsing results. Increase the recommended amount about 10% for each grain above 7. Add an extra 1/4 of the minimum package recommendation for large loads. Also, add an extra 1/4 for heavily soiled, oily loads.
3. UNBUILT SOAPS require the addition of a non-precipitating water softener when used in water over 4 grains hardness.

### Snags On Knit Synthetic Fabrics

Location of snags may give clue as to their source. External sources — tables, counter edges, etc. Machine sources — burrs and flash — agitator, retainer ring, dryer baffles, drum caps. Clothes load — buckles, open zippers.

### Oily Stains On Synthetic Fabrics

Many such stains on synthetic fabrics are blamed on leaking transmissions. This type of problem is more likely related to the increasing use of synthetics and to poor or marginal washing practices. Many of these stains consist of cooking oil or grease and are not visible when they first occur during eating or cooking. The oil acts as a binder and picks up dirt from the wash water and the clothes come out spotted and dirty.

Transmission oil will stain all fabrics in a random pattern. It cannot be washed out. The chart below gives identifying characteristics and removal procedures.

## OIL STAINS

### Food Oils Or Grease Characteristics

1. SYNTHETIC ONLY — NOT COTTONS
2. FRONT OF GARMENT ONLY
3. CAN BE WASHED OUT

### Removal

1. PRETREAT WITH LIQUID DETERGENT
2. IMPROVE WASHING SOLUTION — WATER TEMPERATURE, PHOSPHATE DETERGENT



# **USE & CARE WASHABILITY**

## **Removal**

### **1. PROFESSIONAL DRY CLEANERS**

After you have determined that the stains are from food oils or grease advise the customer —

1. Synthetics are chemically different from cottons.
2. Such stains often become visible only after washing.
3. Need hotter water and more good detergent (preferably phosphate) to remove stains.
4. Pretreating will make stain removal easier. (Wisk, Mr. Clean, Ajax, All Purpose ERA, Cold Water All).
5. Some stains (containing protein) will require a cold bleach soak per instructions on bleach bottle.

### **FABRIC SOFTENER STAINS — ANY FABRIC**

Fabric softener stains are on the increase especially since it is recommended that some softeners be used in the wash water instead of the rinse water. These types of stains can be found randomly located on both synthetics and cottons. They can be removed by pretreating with liquid detergent and following good washing practices.

A simple test kit is available for determining the presence of fabric softener. Equipment required to perform the test is.

1. A range or other source of heat capable of boiling water.
2. A small sauce pan — porcelain or stainless steel.
3. Bromophenol blue dye stock solution in a plastic dropping bottle, WH49X185.

#### **The Test Steps Are:**

1. Boil fifteen drops of dye stock in about eight ounces of water.
2. Place a portion of stained fabric in boiling solution for one minute.
3. Remove fabric, rinse thoroughly, and check for blue color at or around stain. The blue color is a positive identification of fabric softener.

There are no hidden hazards associated with this test. However, NYLON fabric absorbs the dye and will not give satisfactory test results. A very few non-liquid softeners do not respond to this test.

#### **Transmission Oil Characteristics**

1. SHOWS ON ALL FABRICS
2. RANDOM DISTRIBUTION
3. CANNOT BE WASHED OUT — REQUIRES SOLVENT

## LINT ON SYNTHETIC FABRICS

Lint is cotton fiber. The construction of synthetic fibers and fabrics (especially knits) makes them hold on to cotton lint very readily. Therefore, the most important step in reducing lint problems is to properly SORT the items before washing.

1. SEPARATE COTTONS FROM PERMANENT PRESS AND KNITS
2. SEPARATE LIGHT FROM DARK COLORS

OVERWASHING is another cause of lint. It actually wears out the clothes faster. Therefore, use only ONE MINUTE OF WASH TIME PER POUND OF DRY LAUNDRY – NORMAL SOIL. Any more time than this is wasteful and does not usually get the wash load any cleaner. Also, turnover of the wash load is not a major factor of washability.

BACK-OVERFLOW is generally caused by too high a ratio of water level to wash load. The excessively high level causes the wash water to be driven up the side of the outer tub during the early part of the spin cycle. When the water reaches the underside of the machine cover it can only turn inward and back down onto the wash load carrying lint with it. Therefore, advise the customer to avoid the possibility by:

1. Only using HIGH water level for 12 Lbs. or more of dry garments.
2. Reduce water level for smaller loads.

The above items are things that the user can do to reduce lint. Full flow drain out time should be checked to be sure the washer is mechanically correct. The chart below gives maximum time in which full flow drain out should cease with a high water level.

FULL FLOW DRAIN OUT TIME	
MODEL	NO LOAD
LARGE CAPACITY	110 SEC.
STANDARD CAPACITY	95 SEC.

If excessive drain out time exists:

1. Check entire drain hose for kinks.
2. Check tub-to-basket gap. See Page E - 10
3. Check for any obstruction in drain system. Look inside pump.
4. Make sure pump is operating properly. Check with HOT water.
5. Check for excessively long (over 10 ft.) or high (over 8 ft.) drain hose.

## **USE & CARE WASHABILITY**

6. Check to see if filter pan is properly seated. Some filters have been used with a protrusion on the inside which makes them sit up too high on the agitator and the recirculation water stream misses the pan.

### **CARBONATE – BUILT DETERGENTS**

Phosphate-Built detergents generally give better performance than carbonate-built detergents. Carbonate-Built Detergents can produce negative effects on cotton fabrics and on the washer itself. Calcium carbonate builds up on cotton fabrics making them harsh and abrasive. Fabric wear is accelerated. Hot water at about 130°F. is best for reducing build up. Oily soil removal is also best at this temperature. Another way to reduce calcium carbonate build up is:

1. Fill washer with water.
2. Let it agitate for about 3 – 4 minutes.
3. Then add wash load.

In this case, calcium carbonate is not eliminated and, therefore, it is available to build up in the washer and in the plumbing.

A vinegar-water solution can be used to restore stiff, harsh cotton fabrics.

1. Mix 1 – 2 cups of vinegar per gallon of hot tap water in a PLASTIC OR STAIN-LESS STEEL container.
2. Soak garments for about 15 minutes.

### **Precautions**

1. Vinegar is sour solution and may strip resin finish from permanent press garments.
2. Some dyes are adversely affected by sour.
3. Do not use vinegar in or near the washer or other porcelain surfaces.

Calcium carbonate build up in the washer is unsightly and may cause malfunctions. If the build up has progressed to this stage changing the parts is the only approved fix.

The addition of a phosphate water softener (where available) will help to significantly reduce build up in the garments and the washer. Advise the customer to use 1/2 cup water softener in the wash water 1 or 2 times a week.

### **Clogged Filter Pans**

The clogging of filter pans is caused by the calcium carbonate found in most low or non-phosphate detergents.

## USE & CARE WASHABILITY

Clogged filter pans can be cleaned by the customer by using a vinegar-water solution and a brush.

1. For quick cleaning soak the filter pan in a pre-heated 160°F. solution of 50% vinegar and 50% water for 15 minutes. Then brush each side of the pan while flushing with plenty of warm running water.

### **Caution: Do Not Use A Porcelain Container**

2. If the filter pan is heavily scaled or heating is not desirable then soak the pan overnight in a 50-50 solution of vinegar and warm water. Brush and flush.
3. To prevent recurring clogging advise the customer to soak the filter pan overnight in a solution of 2 cups of vinegar and 1 gallon of warm water. Brush and flush. This should be done weekly.

### **Caution Notes:**

When heating soak solution - do not exceed 180°F. Higher temperatures may warp the filter pan.

**DO NOT SOAK IN PORCELAIN CONTAINERS AND DO NOT USE VINEGAR IN OR ON THE WASHER.** Vinegar is a sour solution and will cause etching and subsequent removal of the porcelain from finished surfaces.



## **WASHER DIAGNOSIS**

### **MECHANICAL PROBLEMS**

The following items should be checked when diagnosing for almost all mechanical problems.

**FUSES** or circuit breaker

Push-Pull switch out

Faucets turned on

Machine cordset plugged into wall receptacle

# DIAGNOSIS

## WASHER DIAGNOSIS MECHANICAL PROBLEMS

### CHECK

Washer will not fill	Water supply, faucets on? Hose and/or Valve Inlet Screens Voltage across Valve Coils Water Level Switch Selector Switch #3 Switch (Clam Shell Timer) Printed Circuit Cam (Clam Shell Timer) Timer Switch Contacts (Singer)
Will Not Stop Filling	Water Level Switch Valve Stuck Open Reducer - Cracked Chamber Hose Not Vertical Chamber/Switch Hoses — Leak Obstruction in Chamber Hose Syphoning Out Drain Hose
Fills But Will Not Agitate	Water Level Switch #1 Switch (Clam Shell Timer) #4 Switch (Clam Shell Timer) Start Relay Motor Windings Motor Protector Lid Switch Drive Belt Transmission Timer Switch Contacts (Singer)
Agitates/Spin — Fast Only	Speed Shifter Adjustment Speed Shifter Solenoid Selector Switch Clutch Lower Carrier Plate
—Slow Only	Shifter Bent, Resting on Screw Head
No Spin	Motor Protector Start Relay Motor Windings Lid Switch Drive Belt

## DIAGNOSIS

	Timer Switches Clothes over Side L.G.S. Spring in Transmission Foreign Object thru Bottom Basket Hole
No Pump Out	Restriction In Drain System Pump Coupling Pump Impeller Kinked Drain Inlet Hose Height of Drain Outlet - Should Be less than 8'.
No Spray Rinse	Restriction in Drain System Restriction in Chamber Hose or valve hose. Printed Circuit (Clam Shell Timer) High/Long Drain Hose Water Level Switch Not Resetting Timer Switch Contacts (Singer)
Excessive Vibration/Noise	Level Damping System - Pads, fins, clamps Unbalanced load Basket Balance Ring Counterweight on Suspension Suspension Cable/Pulleys Floor Construction - Weak, Sloped Normal Brake Noise Normal Gear Noise Apron to Base Screws Loose Clutch Bearings Clutch Shoes - Wear Jam Nuts missing or loose
Leaks/Water on Floor	Overflow Nozzle & Tub Restriction in Drain System Machine Level Inlet Spray out Transmission/Tub Boot Inlet Hoses/Couplings Holes in Outer Tub Tub/Cover Gasket Leaks in Drain System Splashing out of Drain.



## **DIAGNOSIS**

Runs continuously  
Dry agitation & spin  
(Singer Timer models)

WLS contacts welded together  
Contacts 16R - 17R welded

Washer starts by itself  
(Singer Timer models)

Leaky Water Valve

Floods during extended soak  
(Singer Timer Models)

Push-Pull switch closed, lid up,  
level system leaks pressure,  
WLS resets.

## 1. Replacement Wire For Harness Repair

To replace or mend a portion of the harness, use WH19X163 No. 18-41 Flamenol wire, white with black stripe, furnished in a 50 foot roll. This special color marking will indicate to a serviceman that the harness has been repaired.

## 2. Low Water Level:

Water level switch will trip too soon (at too low a water level in the tub), if water is trapped in a sagging chamber hose. The chamber hose must be mounted vertically along the side of the tub.

## 3. High Water Level or Flooding

On bottom pressure take-off models the chamber hose from the plastic sump must not sag or lean away from the vertical. The hose must run upward from the sump and be held vertical by the wire hanger. Any sag or leaning can cause the chamber to hold water which can cause over filling and/or flooding.

## 4. Erratic Water Level:

May be caused by a crack in the plastic hose reducer, a pin hole in the hose, or a leaky connection somewhere in the water level sensing system.

## 5. Clamps — Plastic Drain Elbow:

The clamps used with the rubber Drain and Save hoses on SUDS SAVER washers have been incorrectly installed in some cases. These are the clamps which hold the rubber hoses onto the plastic (90° bend) elbow at the rear of the machine. The clamp screw should be installed so that it is in line with the short axis of the oval shaped elbow as shown below. If the clamp is installed with the screw in line with the long axis excessive pressure is put on the elbow and it may collapse when hot water runs through it.

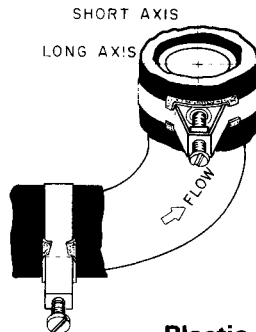


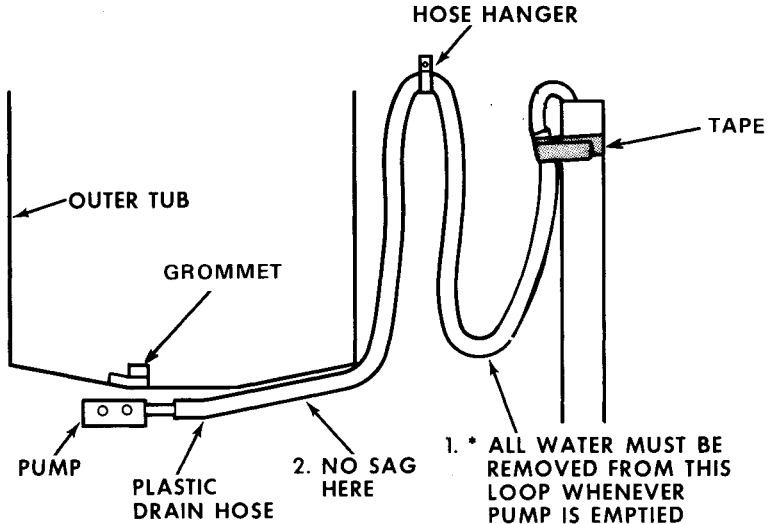
Figure 1

Plastic Elbow — Clamp Position

# FIELD CORRECTIONS

## 6. Wet Clothes/Poor Drain Out:

1. Sag in drain hose. As it leaves the pump the drain hose should not sag. It should be angled upward along the bottom of the tub as it goes up to its hanger near the water valve.



2. Grommet reversed. The drain inlet grommet in the bottom of the tub could be reversed putting the dam on the upstream of the water flow direction. Remove, rotate  $\frac{1}{2}$  turn and reseal in tub using WH60X15 sealer.
3. Drain Inlet Kinked — The drain inlet hose, between the tub bottom and the pump, could be kinked. If this hose has a thin wall and/or it is twisted, even slightly, it could collapse during spin and cut off the flow of water.
4. Motor Protector Trips. The motor protector could be tripping during spin and not completing the cycle.
5. Whenever you change the pump, remove hoses to clean it out, or just lay the washer over, empty the drain hose completely everytime. Failure to do so can result in an airlock causing the pump not to function in the drain direction.

NOTE: Also see Item 12.

## 7. Clogged Pump - Tub Full Of Water

To remove article of clothing from drain pump, when tub cannot be emptied because pump is clogged:

- a. Use hose pinch-off pliers (Robinair No. 12757) to clamp the drain hose from tub (or sump) to pump.
- b. Remove 3 pump mounting screws from tub brackets.
- c. Now, remove input and output drain hoses from pump ports.
- d. With needle-nose pliers, pull out obstruction.

This sequence is necessary in order not to disturb or break the bond between the tub and hoses.

The pump body is made of plastic, and while this material has excellent non-corrosion properties, care should be taken not to drop it on a hard surface.

## 8. Clutch Shim

The factory has been using a shim (washer) between the end of the drive motor shaft and the shaft extension on TWO-SPEED Motor and Clutch assemblies in order to raise the clutch assembly up away from the motor support. The shim is necessary because the motor shaft has a tolerance of .080 inches on its length; and when this tolerance is on the low side, the finger on the inner lock-in shoe can hit on the motor support.

Therefore, ALWAYS check for and replace the shim when servicing the 2-speed clutch. On clutches having no shim it may be necessary to add one, if the motor is being replaced. A 1/2" O.D. x .030" thick flat washer will do the job. You should always rotate the lower carrier plate manually to check for interference before leaving the machine, and be sure to check shifter operation for any adjustment that may be necessary.

## 9. Squeaking Friction Pads

Usually caused by dampness or oil on pads. To correct, clean friction pads and fins. Roughen surface of pads with fine sandpaper or replace friction pads. Do not use oil or any lubricant on friction pads.

## 10. Clogged Valve Screens

- a. Check and clean or replace screens. If local water supplies tend to clog screens, add screened washer (WL2X149) to faucet end of each supply hose for easier cleaning. The coned screens should be pointed toward faucets.

# FIELD CORRECTIONS

## b. Backflushing

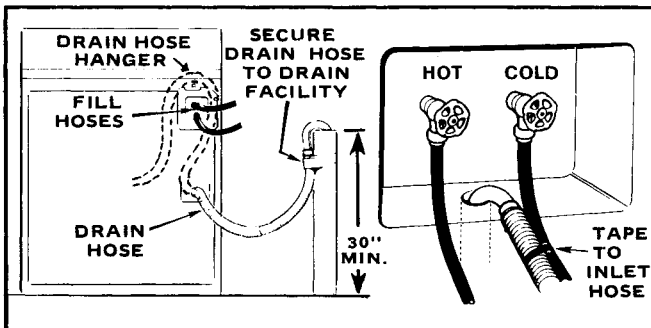
1. Determine which side of the valve is clogged and remove that intake hose from the faucet; water shut off, of course.
2. Put disconnected end of intake hose into washer basket or drain.
3. Set selector switch for WARM WASH. This energizes both valve coils.
4. Set timer dial for WASH and pull out knob.
5. Open faucet and run several gallons of water thru the valve and hose.
6. Reconnect hose and do other side if necessary.

This method should back flush the screen(s) with minimum of effort and time.

7. You may find it necessary to use a new hose washer at the faucet to eliminate leaks.

## 11. Drain Hose Jumps Out Of Drain Facility

The drain hose **MUST** be taped or otherwise securely fixed to the stand-pipe, intake hose, or set tub to prevent the nozzle from jumping or lifting out during spin. The pictures below will give you some idea on how this can be accomplished.



## 12. No Recirculation and/or Incomplete Pump Out

A problem of no recirculation and/or incomplete pump out of the washer tub can be caused by an air locked pump. If the intake and exhaust nozzles (ports) on the pump are pointed downward an air pocket can form inside either or both of the pump cavities which will result in the above mentioned problems.

To correct this problem loosen all three pump mounting screws. Place one or more flat washers (up to a 1/4" thickness) between the top of the pump and the pump mounting bracket (on the tub bottom) which is nearest the FRONT of the washer. This will point the pump nozzles level or upward and any air inside the pump can escape.

NOTE: Also see Item 6.



## INDEX

	<b>PAGE</b>
<b>OPERATING SPECIFICATIONS</b>	
<b>General Requirements &amp; Specifications</b>	K - 2
<b>COMPONENT SERVICING</b>	
Backsplash Asm.	K - 5
Basket - WWP1150V	K - 6
Belt & Motor	K - 12
Button Trap - WWP1150V	K - 12
Clutch Asm. - WWP1150V	K - 8
- WWP1150B	K - 9
Cover & Lid	K - 6
Off Balance/Lid Switch	K - 6
Pump - WWP1150V	K - 12
Pump & Trap - WWP1150B	K - 12
Spin Solenoid	K - 12
Timer	K - 5
Tub Cover & Basket - WWP1150B	K - 7
Tub Replacement	K - 11
Tub Seals - WWP1150V	K - 11
<b>ELECTRICAL</b>	
Cycle Description	K - 14
Schematic	K - 18
Timer, Cam Charts	K - 13

For 24" Washer See Manual 31-2105



**COMPACT AUTOMATIC WASHER**

**GENERAL REQUIREMENTS AND SPECIFICATIONS**

**General**

1. **LOCAL CODES** – The installation must conform with local code and ordinance requirements.
2. **LOCATION** – The washer is designed to operate on firm, level flooring. It should not be operated on excessively weak or sloping floor surfaces.

**Caution:**

Never operate or store the washer in locations where it could conceivably create a hazard, such as top of stairs or edge of unguarded landing.

**Electrical**

Washer is to be supplied by a 120 volt, 60 Hertz circuit and terminated in a properly grounded three-prong wall receptacle.

**Grounding**

**Important – Please Read Carefully !**

**For Personal Safety, This Appliance Must Be Properly Grounded.**

The power cord on this appliance is equipped with a three-prong (grounding) plug which mates with a standard three-prong (grounding) wall receptacle. Figure 1.

Where a standard two-prong wall receptacle is encountered, it is the personal responsibility and obligation of the customer to have it replaced with a properly grounded three-prong wall receptacle.

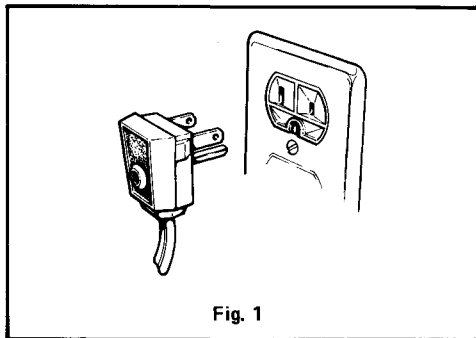


Fig. 1

**DO NOT, UNDER ANY CIRCUMSTANCES, CUT OR REMOVE THE THIRD (GROUND) PRONG FROM THE POWER CORD PLUG.**

**IF THERE IS ANY DOUBT AS TO WHETHER THE WALL RECEPTACLE IS PROPERLY GROUNDED, THE CUSTOMER SHOULD HAVE IT CHECKED BY A QUALIFIED ELECTRICIAN.**

### **Plumbing**

- 1. WATER PRESSURE** – Must be 10 p.s.i. minimum to 150 p.s.i. maximum static pressure measured at faucet.
- 2. WATER TEMPERATURE** – Hot water heater should be set to deliver 140<sup>o</sup> to 150<sup>o</sup> F. water IN THE WASHER, when hot wash is selected. However, water temperature must not be over 180<sup>o</sup> F.

# WWP

## WWP1150

### The WWP1150 HAS 3 SEPARATE CYCLES –

Regular – 28-1/2 min.

Gentle – 15 min.

Permanent Press & Poly Knit – 22-1/2 min.

All times are plus fill periods. Washing is accomplished by a pulsator which rotates continuously for 19 seconds in one direction, pauses, and then reverses for 19 seconds (Regular Cycle).

### OPERATING SPECIFICATIONS WITH 115 VAC. 5 LB CLOTHES LOAD

	Wash/Rinse	Drain	Spin
Current (Amps)			
Watts			
Pulsator RPM	710	–	–
Basket RPM	–	–	820
Main Motor RPM			
Pump Motor RPM			
Pump Out Rate			
Total Power Consumption Per Cycle			

### REVERSES EVERY 19 SECONDS

WATER USAGE (No Load)	High	Med.	Low
Per Fill	11.7	9.5	8.3
Complete Cycle	24.6	20.2	17.8

Wash water temperature selection on plumbed – in models is Hot, Warm, and Cold. All rinses are cold. For single hose installation using the unicouple, water temperature is controlled by adjusting the faucets.

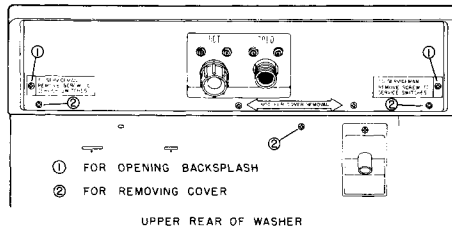
The WWP1150 is produced as a portable washer using a unicouple for fill and drain. It may be converted to a permanent installation using SALES KIT PIK – 1.

## BACKSPLASH ASSEMBLY

The backsplash assembly contains the following items:

1. Timer
2. Temperature Selector Switch
3. Water Level Switch
4. Lid/Off Balance Trip Switch
5. Water Valves
6. Valve to Inlet Hoses

To open the backsplash (BS) asm. the control panel (CP) must be removed. The 2 most outboard Phillips screws on the back of the BS must be removed. Pull the top of the CP out a little. Lift the CP so that its bottom tabs come out of the slots in the cover. Then roll the CP all the way out. This leaves it face down with all of the BS components exposed.



The timer, selector switch (SS), water level switch (WLS), lid switch (LS) are all mounted with Phillips screws from the inside. The water valves are also mounted with Phillips screws but from the outside.

**NOTE:** Metric sheet metal screws can be replaced by American screws but screws with metric machine threads must be replaced by same.

The lid switch is replaceable as an assembly or as an individual part. Two Phillips screws hold the assembly in place and a Phillips machine screw holds the switch to its mounting bracket. It will require a stubby Phillips screw driver to remove the switch while it is still in the backsplash.

### Timer

The timer is not serviceable and should be replaced if faulty. The dial pointer is key-

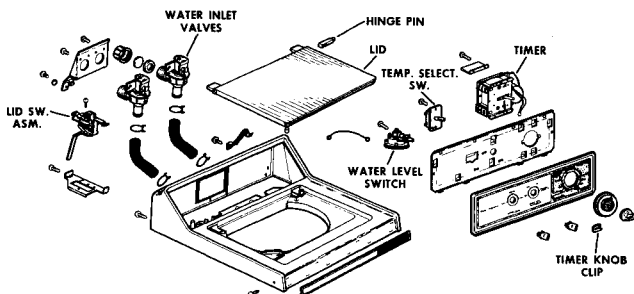
## WWP

ed to the timer shaft by a roll pin. The knob is held to the shaft by a plastic clip.

### Off Balance/Lid Switch

This switch will open and all functions will stop during spin, if the lid is opened or an off balance condition occurs.

The switch is reset by raising the lid. Switch adjustment is made by moving the switch up or down on its own mounting screw. The machine should cut off when the lid is opened a maximum of 2 inches.



### Cover & Lid

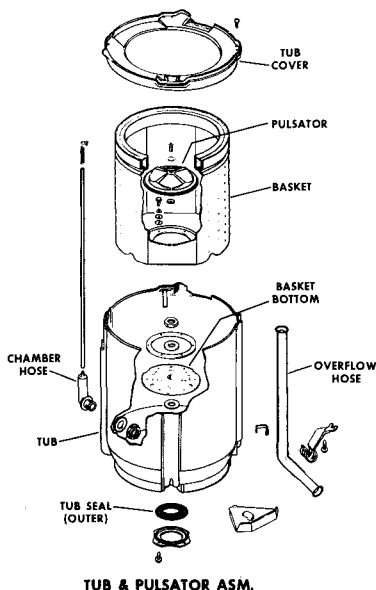
The lid is removable without having to remove any screws. Raise the lid and with a screwdriver depress the detent on the right hand hinge pin. Force the hinge pin to the left and when it becomes disengaged from the cover lift it out.

Five screws hold the cover in place — 1 on each side at the front, the 2 lowest out-board screws in the rear of the backsplash, and the screw just to the upper left of the drain nozzle. For complete removal of the cover it will be necessary to disconnect the WLS hose at the plastic air chamber on the rear of the tub. In addition one 6-way terminal block must be disconnected. Note that the bleach funnel and the water inlet are both an integral part of the cover. The front trim is held in place by bent tabs.

### Basket — WWP1150V

To remove the basket 4 screws and the plastic tub cover must be removed. Next the large Phillips screw in the center of the pulsator comes out. This screw turns independent of the pulsator. Remove the large nut on the pulsator shaft and lift out the basket assembly. This may require use of the basket puller.

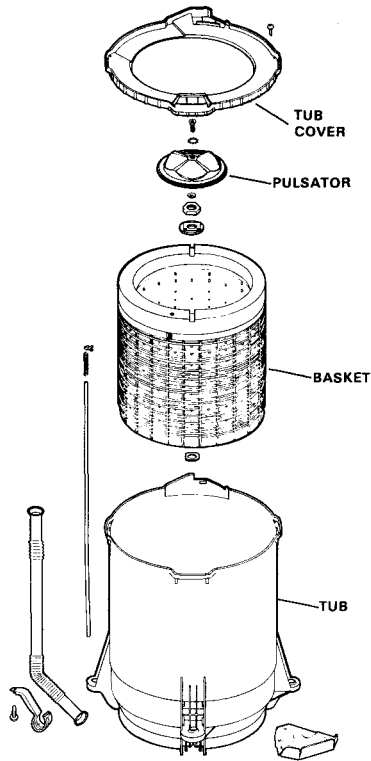
The basket can be re-assembled by reversing the disassembly procedure. Be sure to have a large washer above and below basket hub.



## TUB COVER & BASKET — WWP1150B

The tub cover is held in place by 3 Phillips screws and 3 tabs. Remove the 3 screws and snap the cover out of the tub. Next, remove the large Phillips screw out of the center of the pulsator. This screw turns independently of the pulsator. Remove the large nut on the shank of the gear drum and lift out the basket. Due to the light weight of the basket it may be necessary to shock the nut loose by striking the T bar or ratchet handle with a hammer. Basket removal may require the use of a puller

**B MODEL  
TUB & PULSATOR**

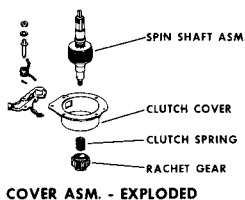
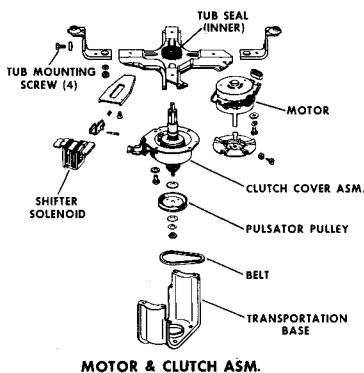


The basket can be reassembled by reversing the above procedure. Be sure to put the square flange washer below the basket and the double washer between the basket and the nut. Use EC-800 sealer on the surfaces of both the flange washer and the large nut. To insure proper tightening of the nut strike the T bar or ratchet handle with a hammer.

**Clutch Assembly — WWP1150V**

The clutch assembly is mounted on the tub support by Hex screws (13 MM). First remove cover and basket and then turn washer upside down. Remove transportation base — 4 Phillips screws. This base need not be replaced.

Remove nut (24 MM) and pulsator pulley. Lift off ratchet gear and clutch spring. Remove 4 Hex screws (13 MM) and clutch cover assembly. The spin shaft assembly can now be removed. It may be necessary to tap on the pulsator end of the spin shaft inside the tub to accomplish removal.



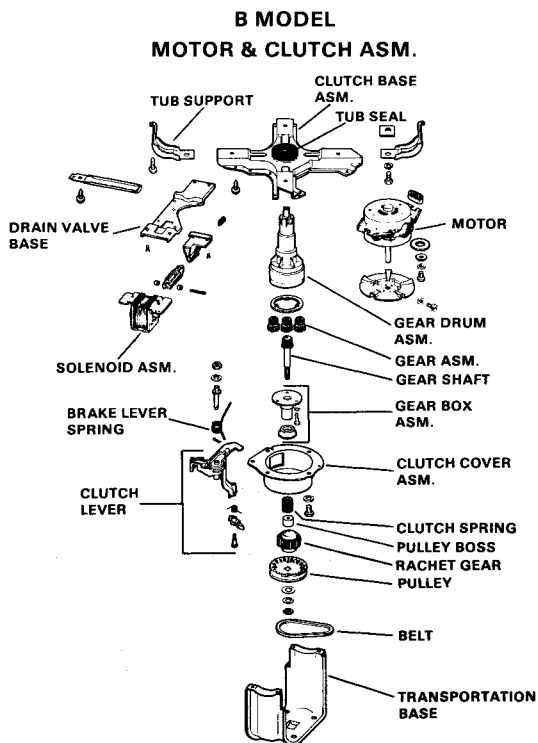
## CLUTCH ASSEMBLY — WWP1150B

The clutch assembly is the major difference between the WWA1150V and the WWA1150B. The new clutch has 3 intermediate gears which are all driven by the input gear shaft. These gears, in turn, all drive the pulsator shaft and pinion. The intermediate gears are made of plastic and it is possible they may have to be replaced at some time.

To replace or inspect the intermediate gears remove the machine cover, tub cover, pulsator, and basket. Turn the machine upside down.

Remove the 4 Phillips screws holding the transportation base. Discard both the base and screws. Remove the 2 Phillips screws holding the solenoid assembly to the clutch base asm. Next, remove the 4 Hex screws that hold the clutch cover to the clutch base. One screw is hidden under the clutch lever assembly. Rotate the ratchet to get at the screw. You can remove the pin and large ratchet spring if you wish. This will make it easier for subsequent parts to come off.





Remove the pulley nut and pulley. Lift off the ratchet gear, clutch spring, and pulley boss. Push the clutch out of its cover. Remove the 3 screws that hold the gear box to the gear drum. If the gear box and shaft do not come out easily reattach the pulley and nut temporarily. This will give you something to pull on to remove the gear box.

The 3 intermediate gears can now be removed. The remaining parts cannot be disassembled any further.

The replacement intermediate gears come as a set of three. An assembly tool is also included to insure that the gears are positioned exactly as shown. Otherwise, excessive gear wear will occur.

Place the 3 new gears on the pins on the assembly tool. Slide the 3 gears onto the 3 pins in the gear drum. Remove the assembly tool.

## Tub Seals — WWP1150V

There are two parts to the rubber seal between the shaft and the tub. These two parts mate together and are accessible by removing the center case assembly. Remove 4 Hex nuts (14 MM) for the inner part and 4 additional Phillips screws for the outer part.

## Tub Replacement

For tub replacement it is not necessary to dismantle most of the parts on the bottom of the tub.

From the top of the cabinet remove the 4 clips from the rods in the snubber assemblies.

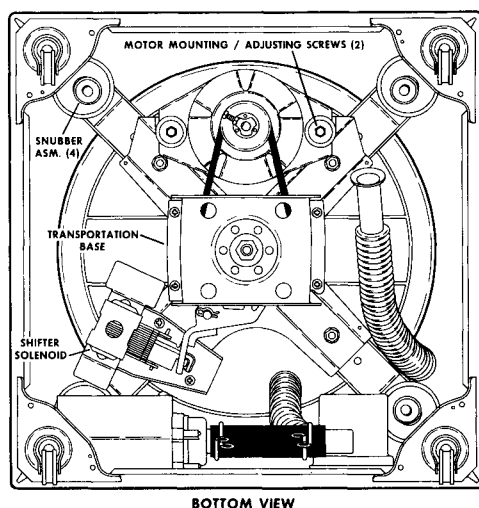
Disconnect the 2 terminal blocks from the motor and the spin solenoid.

Disconnect the pump hose from the tub bottom.

Lift the cabinet off the tub assembly after taking the snubber assemblies out. Note the color of the springs for proper replacement location.

Remove 4 screws on the side of the tub and lift off the entire drive system and brackets assembly.

Remove just a few more Phillips screws and the tub is stripped.



BOTTOM VIEW

# WWP

## Belt And Motor

The belt can be replaced or adjusted by simply loosening the 2 Hex screws (13 MM) on the side of the motor. To replace the motor remove these same 2 screws and disconnect the one 3-way terminal block from the harness at the rear of the machine.

## Spin Solenoid

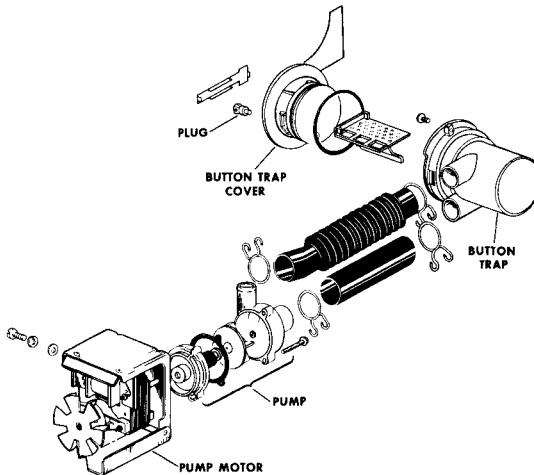
The spin solenoid can be replaced by removing 2 Phillips screws and the one 3-way terminal block connection at the rear of the washer. To remove the solenoid armature (plunger) straighten and remove the large cotter key. To remove the brake lever assembly first release the spring from its detent. Note position of spring for replacement. Remove clip from end of lever shaft and lift off lever assembly.

## Pump — WW1150V

To remove pump disconnect hose from button trap and remove 3 Phillips screws from rear of cabinet. The exploded view of the pump and button trap shoe detailed disassembly.

## Button Trap — WWP1150V

To remove the button trap first empty it by pulling out rubber plug. Unscrew button trap cover and remove 1 Phillips screw. Disconnect 2 hoses.

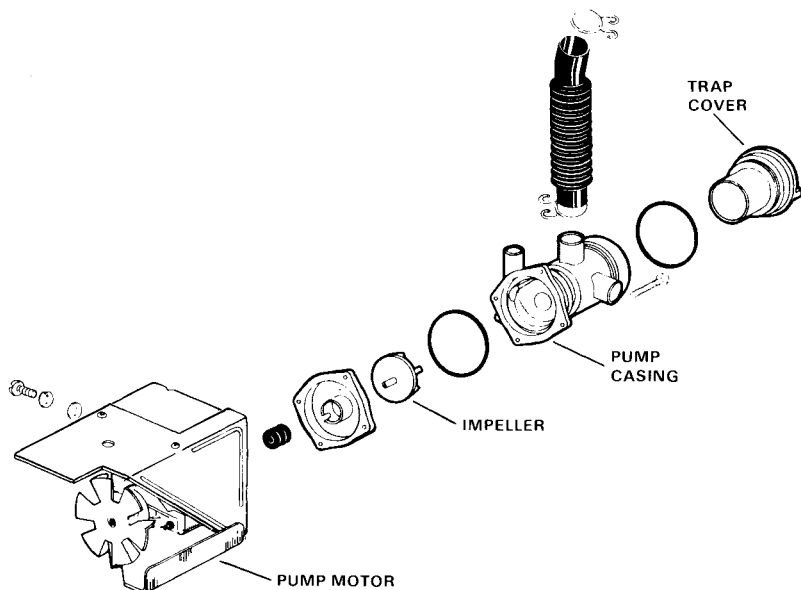


PUMP & BUTTON TRAP SYSTEM

## PUMP & TRAP

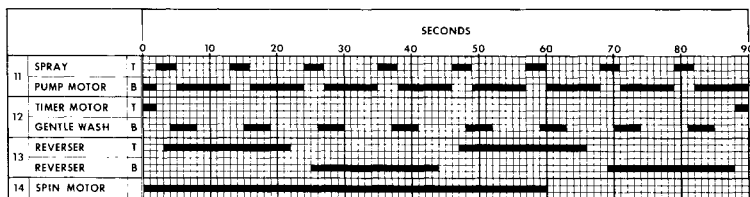
The major difference in the drain pump assembly is that it no longer has the customer accessible button trap. The button trap is much smaller and the round plate on the lower rear of the cabinet must be removed to get to it.

### B MODEL PUMP & TRAP



## Timer, Cam Chart, Schematics

The timer is a Japanese Singer model. It has 2 switch assemblies that ride on 2 peripheral cams. The first cam is driven by the motor and makes 1 continuous revolution in 90 seconds. At the end of each revolution the second cam is advanced by one 90 second increment. This means that all of the functions that are controlled by the second cam are divided into 90 seconds pluses.



FIRST CAM, CONTINUOUS DRIVE, 90 SECOND CYCLE

# WWP

There is nothing exotic in the REGULAR cycle. The only functional switch that is controlled by the first cam during this cycle is No. 13. This is the motor reverser switch and it changes motor direction every 19 seconds with a 3 second pause in between.

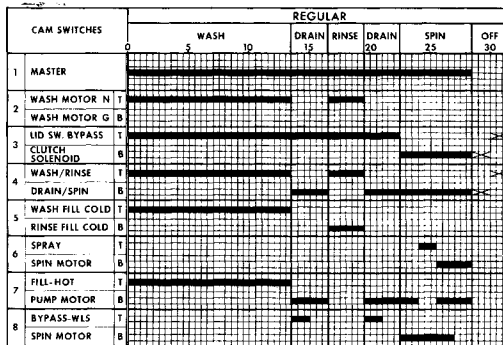
During GENTLE cycle Agitation this 19 second motor pulse is broken up by the No. 12 switch and we get 4 seconds of agitation alternated with 7 seconds of pause. During each Drain period there is a 90 second intermittant Spray. It is 3 seconds On and 8 seconds Off.

Note that the No. 6B, 8B & 14 switches are designed as Spin motor switches. The No. 6B and 14 switches are in series with each other. In turn they are in parallel to the No. 8B switch. Now, during GENTLE Spin the No. 8B switch provides current for the spin motor function for the first two 90 second increments. For the last increment the No. 6B & 14 provide current but the No. 14 switch is closed only for 60 seconds so that there is no Spin during the last 30 seconds even though power is still ON in the rest of the machine.

## Cycle Description

### REGULAR CYCLE

Wash Agitation .....	13.5	Minutes
Drain.....	3	
Rinse.....	3	
Drain.....	3	
Final Spin .....	6	
	<b>28.5</b>	<b>Minutes</b>



CAM CHART, SECOND CAM - REGULAR CYCLE  
TIME IN MINUTES

During agitation (Wash & Rinse) the pulsator rotates at 710 RPM for 19 seconds in one direction, stops for 3 seconds, then 19 seconds in the other direction.

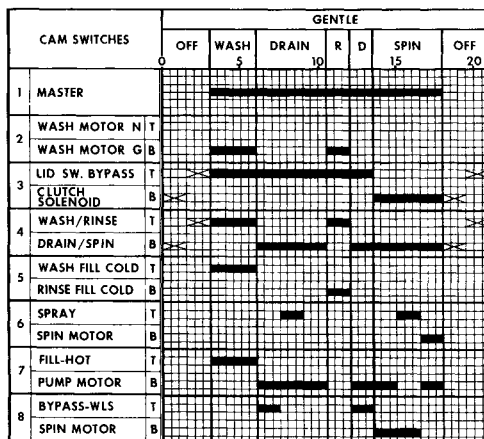
During the Drain periods only the drain pump and the timer operate so we have a down drain without any spin or spray.

During Rinse Fill the hot water solenoid is electrically isolated so that we only get a cold rinse.

During Final Spin we get a 90 second Spray Rinse which starts 1½ minutes after Spin begins. The pump does not run during this Spray Rinse. Spin continues for another 3 minutes and then the washer shuts Off.

**GENTLE CYCLE**

Wash Agitation ..... 3 Minutes  
 Drain ..... 4.5  
 Deep Rinse ..... 1.5  
 Drain ..... 1.5  
 Final Spray ..... 4.5  
 15.0 Minutes



**CAM CHART, SECOND CAM - GENTLE CYCLE  
 TIME IN MINUTES**

Wash and Rinse agitation during the GENTLE cycle consists of two 4 second rotations in one direction and then two 4 second rotations in the other direction. Each of the 4 second rotations is separated by a 7 second Off period. This is in place of the 19 second rotations period described in the REGULAR cycle.

During the first drain period the pump runs for the entire 4.5 minutes. 1.5 minutes after beginning of drain we get a 90 second period of intermittent Spray. This Spray is 3 seconds On and 8 seconds Off and comes on 8 times.

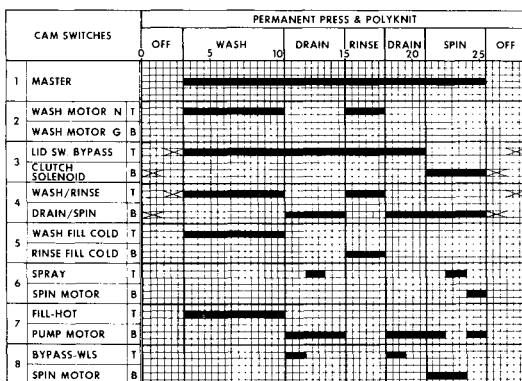
There is no Spray during the second Drain which is only 1.5 minutes long.

During Final Spin there is a 1.5 minute pump out, a 1.5 minute Spray without pump out, and lastly another 1.5 minute pump out.

There is a caution to be noted when using the GENTLE cycle. Because of the reduced times and the intermittent cycles just described the maximum recommended load is 2.5 lbs of dry fabrics. Note that this is so mentioned on the lid instructions.

PERMANENT PRESS & POLYKNIT CYCLE

Wash Agitation .....7.5 Minutes  
 Drain .....4.5  
 Rinse ..... 3  
 Drain ..... 3  
 Final Spin .....4.5  
 22.5 Minutes



CAM CHART, SECOND CAM - P P & P K CYCLE  
 TIME IN MINUTES

The PP & PK cycle is the same as the REGULAR cycle except for:

1. Overall time.
2. A 90 second Spray Rinse in the middle of the first Drain similar to the GENTLE cycle.

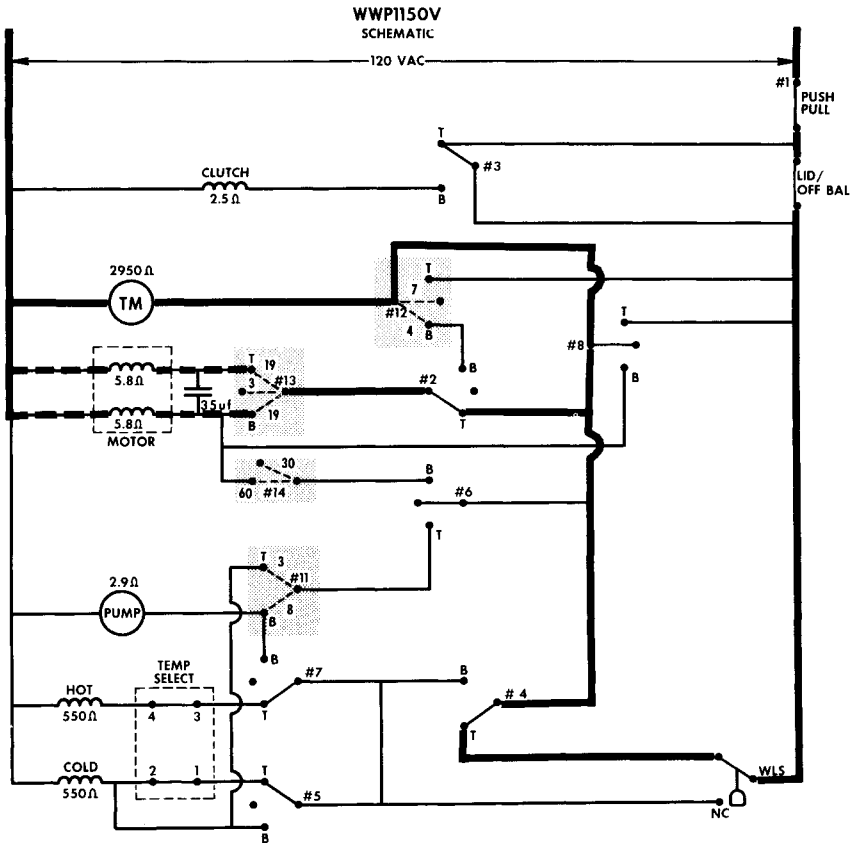


# WWP

## Schematic

Switches 11, 12, 13, & 14 are actuated by the first cam which runs continuously in 90 second cycles. These four switches are shown with a shaded background and their wipers are shown as broken lines. The number by each wiper position is the time in seconds that the switch is closed in that position.

The solid heavy line indicates the closed circuits during Wash and Rinse agitation in the REGULAR cycle. The broken heavy line thru the motor winding indicates the changing phase shift of the motor windings controlled by the No. 13 switch.



**REGULAR CYCLE - WASH / RINSE AGITATION**  
**WASH TEMPERATURE SELECTED WARM**

**AUTOMATIC DRYER  
TABLE OF CONTENTS**

**GENERAL**

<b>Subject</b>	<b>Section</b>
GENERAL	P
CYCLES & CONTROL SYSTEMS	Q
HEAT SYSTEMS & THERMOSTATS	R
DRUM DRIVE & AIR FLOW	S
CABINET CONSTRUCTION & ADJUSTMENTS	T
DIAGNOSIS	U
SAFETY PRACTICES	V
FIELD CORRECTIONS	W
PORTABLE AUTOMATIC DRYER (PAD)	X

## GENERAL

This HANDBOOK covers both General Electric and Hotpoint Automatic Clothes Dryers produced from 1978 thru 1986. All pertinent service information after August 1986 will be issued via SERVICE BULLETINS and will be re-released in the next issue of the HANDBOOK.

The GENERAL ELECTRIC model numbers have the first suffix letter (Model Series) of P, V, B, D or G. See Page P3 for complete model number description. The serial number prefix letter also described on Page P3.

The HOTPOINT model numbers have the first suffix letter (Model Series) of P, T, W, A, B, or D. See Page P3 for complete model number description. The serial number prefix letters are also described on Page P3.

**ELECTRIC DRYERS** — as they leave the factory all electric dryers except portable compacts, are made to operate on 240 volts. A few of the General electric models can be wired in the field for 120 volt operation. Models with TIMED cycles only and the ELECTRONIC CONTROL system models are also approved for use on 208 Volts without any changes.

**GAS DRYERS** — as they leave the factory all gas dryers are made to operate on NATURAL gas. A field conversion must be made for any other fuel. Consult the machine rating plate for the type gases approved for a particular dryer model. The parts catalog pages show the correct conversion kit numbers. All necessary parts and complete instructions are included in the kits.

**CAPACITY-DRYERS** in this HANDBOOK are made in four different capacities - SCD, LCD, LLCD and COMPACT. This description is used throughout this HANDBOOK.

**SCD - Standard Capacity Dryer**

**LCD - Large Capacity Dryer (1970 "L" thru 1982 "B" models)**

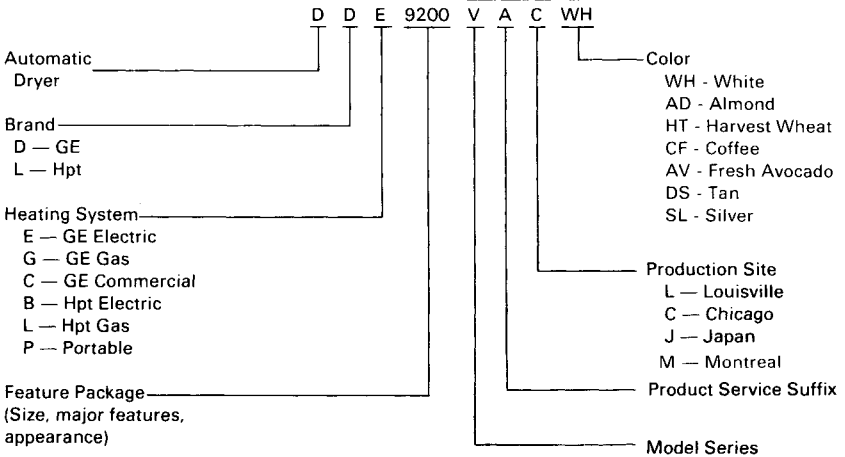
**LLCD - Large Capacity Dryer (1983 "D" model & later)**

For 24 Inch Dryer See 31-2105.

**AUTOMATIC DRYER  
NAMEPLATE DATA**

MODEL NUMBER

MODEL SUFFIX LETTERS



**Serial Number Prefix Codes**

1st Letter		2nd Letter	
<u>MONTH</u>		<u>YEAR</u>	
JAN	A	1973	P
FEB	D	1974	T
MAR	F	1975	V
APR	G	1976	Z
MAY	H	1977	A
JUN	L	1978	D
JUL	M	1979	F
AUG	R	1980	G
SEP	S	1981	H
OCT	T	1982	L
NOV	V	1983	M
DEC	Z	1984	R
		1985	S
		1986	T
		1987	V
		1988	Z



## CYCLES & CONTROL SYSTEMS

### INDEX

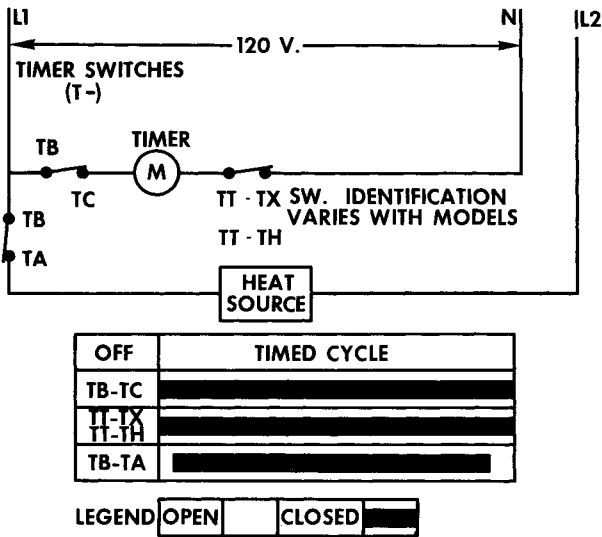
	PAGE
<b>CYCLES - ELECTRIC DRYERS</b>	
<b>AUTOMATIC TEMPERATURE CONTROL (ATC)</b>	
Basic Timer Operation	Q - 6
Fluff Cycle	Q - 7
(LCD), (LLCD)	Q - 9
(SCD),	Q - 7
<b>ELECTRONIC SENSOR CONTROL</b>	
Basic Timer Operation	Q - 11
(LCD), (LLCD)	
<b>TIMED CYCLE MODELS</b>	
Basic Timer Operation	Q - 2
Fluff Cycle	Q - 2
(SCD), (LLCD)	Q - 3
<b>CYCLES - GAS DRYERS</b>	
<b>AUTOMATIC TEMPERATURE CONTROL (ATC)</b>	
Basic Timer Operation	Q - 17
Fluff Cycle	Q - 19
<b>ELECTRONIC SENSOR CONTROL</b>	
Basic Timer Operation	Q - 23
<b>TIMED CYCLE MODELS</b>	
Basic Timer Operation	Q - 14
Fluff Cycle	Q - 14
(SCD), (LLCD)	Q - 15
<b>EXTRA CARE</b>	Q - 26
<b>PRESS GUARD</b>	Q - 27

# CYCLES & CONTROL SYSTEMS

## ELECTRIC DRYERS TIMED CYCLE MODELS

### Basic Timer Operation

When TIMED drying is selected, the drying time in minutes is set on the timer dial. The fabric type or temperature is set with the selector switch. Actuating the safety start switch starts the dryer and timer operation begins, as shown in the simplified circuit below.



**Figure 1 - Simplified Schematic**

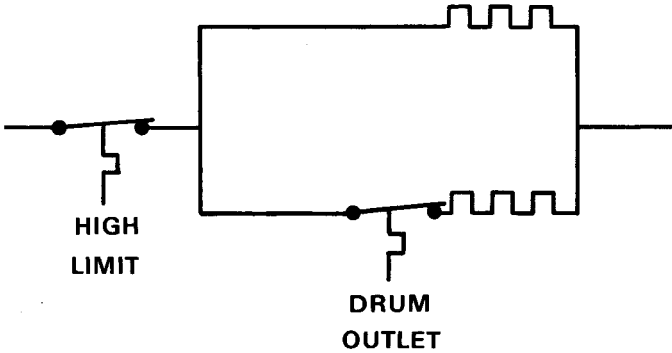
If the timer dial is not in an OFF zone, Switches TB-TC & TT-TX are closed. Drying temperature is controlled by the thermostat system.

### Fluff Cycle

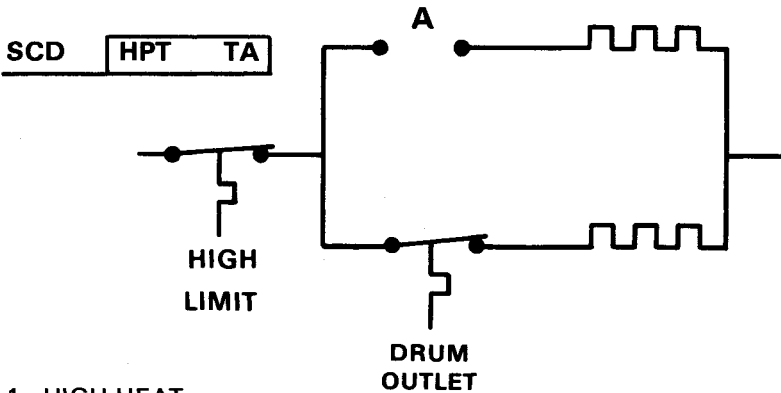
All selector switches to the heaters are open. The dryer tumbles without heat for the number of minutes selected on the timer. Timed cycle only.

(SCD), (LLCD)  
TIMED CYCLE MODEL

SCD GE - VA — NO SELECTOR



There are no selector switches in this circuit. Both heaters operate initially until the drum outlet thermostat opens. Then, only one heater remains on as the drum outlet will not usually reset. The timer runs continuously. There is no FLUFF cycle.



1. HIGH HEAT

Switch A is closed. Both heaters operate initially until the drum outlet thermostat opens. Then, only one heater remains on as the drum outlet will not usually reset. The timer runs continuously.

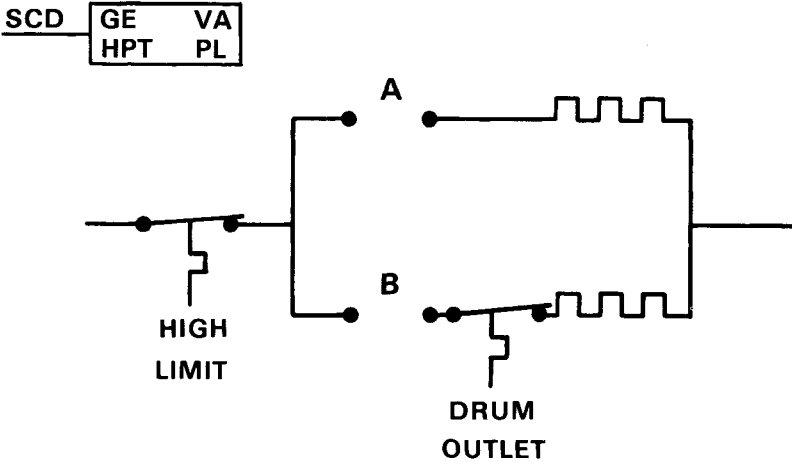
2. LOW HEAT

Switch A is open. Only one heater operates and is cycled by the drum outlet thermostat. The timer runs continuously.

3. There is no FLUFF cycle.



# CYCLES & CONTROL SYSTEMS

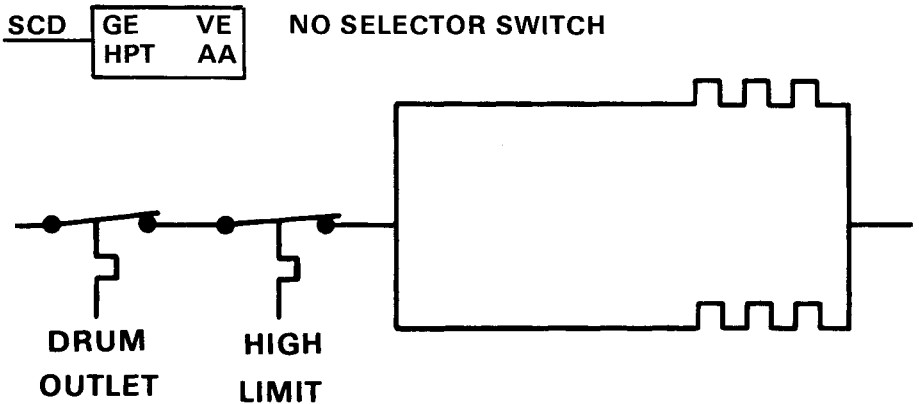


## 1. COTTONS, PERMANENT PRESS, POLYKNITS, NORMAL (High Heat)

Both selector switches A & B are closed. Both heaters operate initially until the drum outlet thermostat opens. Then, only one heater remains on as the drum outlet will not usually reset. The timer runs continuously.

## 2. DELICATE (Low Heat)

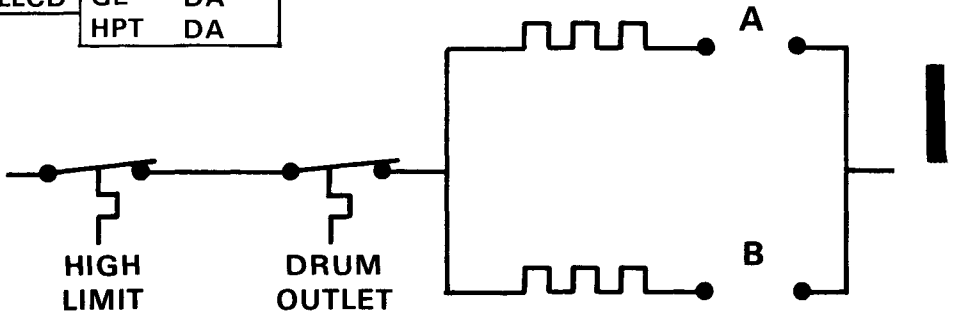
Only selector switch B is closed. Only one heater operates and is cycled by the drum outlet thermostat. The timer runs continuously.



Both heaters operate until the drum outlet thermostat opens. Both heaters are cycled by the drum outlet. There is no FLUFF cycle. The timer runs continuously.

# CYCLES & CONTROL SYSTEMS

SCD	GE	VE,BA
	HPT	AA,BA
LLCD	GE	DA
	HPT	DA



## 1. COTTONS, PERMANENT PRESS, POLYKNITS, NORMAL (High Heat)

Both selector switches A & B are closed. Both heaters operate and are cycled by the drum outlet thermostat. The timer runs continuously.

## 2. DELICATE (Low Heat)

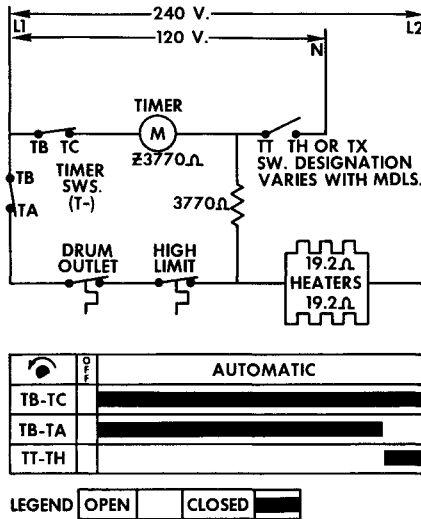
Only selector switch B is closed. Only one heater operates and is cycled by the drum outlet thermostat. The timer runs continuously.

# CYCLES & CONTROL SYSTEMS

## ELECTRIC DRYERS AUTOMATIC TEMPERATURE CONTROL (ATC) MODELS

### Basic Timer Operation

When automatic drying is selected, the timer dial is set in the automatic zone. The fabric type or temperature is set on the selector switch. Actuating the safety start switch starts the dryer.



**Figure 3 — Simplified Schematic**

(Refer to the simplified circuit above.)

240V is applied to the heaters and drying begins. The timer does not operate at this time because it is bypassed by the TB - TA timer switch and the thermostats which are all closed. The TT - TH timer switch is open when automatic drying is selected. When drying temperature is reached, the drum outlet thermostat opens. This removes the bypass circuit around the timer and a new series circuit is established. The new circuit is the timer, the 3770 ohm resistor and the heaters across 240V. The heaters being less than 10 ohms can be disregarded, leaving the timer and the resistor to divide the voltage. The impedance of each being approximately the same allows the timer to see 120 volts and timer operation begins.

# CYCLES & CONTROL SYSTEMS

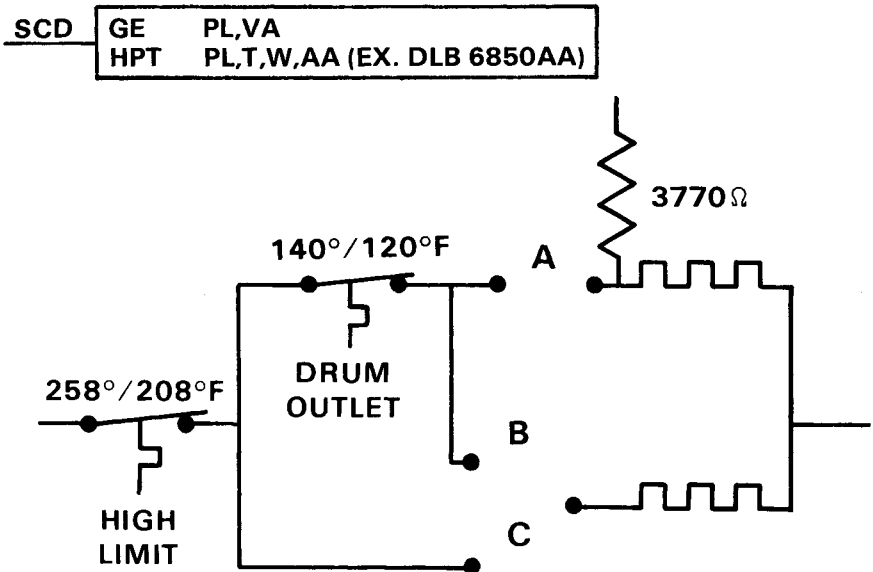
When the dryer cools down to the reset point of the drum outlet thermostat, the drum outlet will close, bypassing the timer and re-establishing the heater circuit. This alternate action of heat and timer operation continues until the end of the cycle when timer switch TB - TA opens, and TT - TH closes, preventing additional heat (cool down) and providing continuous timer operation into the OFF zone. The cool down period is 8 -10 minutes.

## Fluff Cycle - All Models

All selector switches to the heaters are open. The dryer tumbles without heat for the number of minutes selected on the timer. Timed cycle only.

(SCD)

## AUTOMATIC TEMPERATURE CONTROL (ATC) MODELS



### 1. COTTONS (Normal)

Selector switches A & B are closed. Both heaters operate and are cycled by the drum outlet thermostat. The timer runs only when the drum outlet is open and also during the cooldown period.

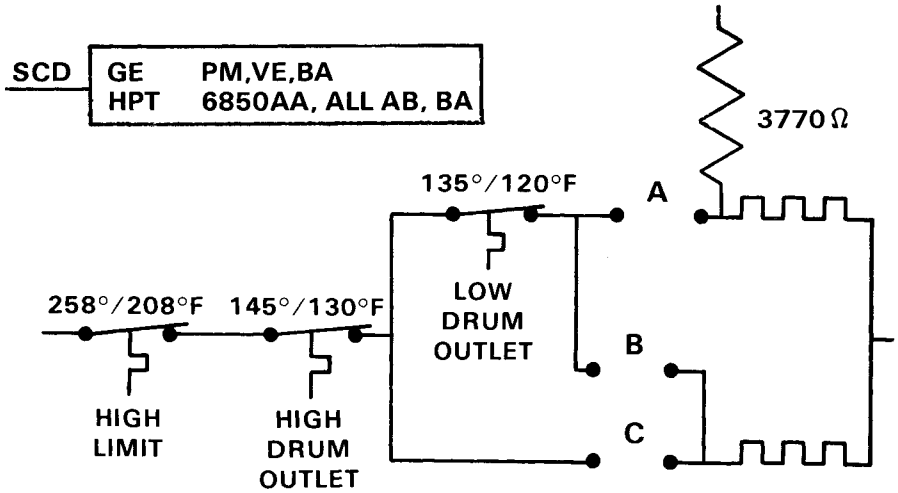
# CYCLES & CONTROL SYSTEMS

## 2. PERMANENT PRESS, POLYKNIT (Normal)

Selector switches A & C are closed. Both heaters operate initially until the drum outlet thermostat opens. Then, only one heater remains on as the drum outlet will not usually reset. The timer runs only when the drum outlet is open and also during the cooldown period.

## 3. DELICATE (Low Heat)

Only selector switch B is closed. Only one heater operates and is cycled by the drum outlet thermostat. The timer runs continuously because this cycle is used only with the TIMED setting.



## 1. COTTONS (High Heat)

All selector switches are closed. Both heaters operate and are cycled by the high drum outlet thermostat. The low drum outlet opens and stays open with no effect. The timer runs only when the high drum outlet is open and also during the cooldown period.

## 2. PERMANENT PRESS, (Medium Heat)

Selector switches A and B are closed. Both heaters operate and are cycled by the low drum outlet thermostat. The timer runs only when the low drum outlet is open and also during the cooldown period.

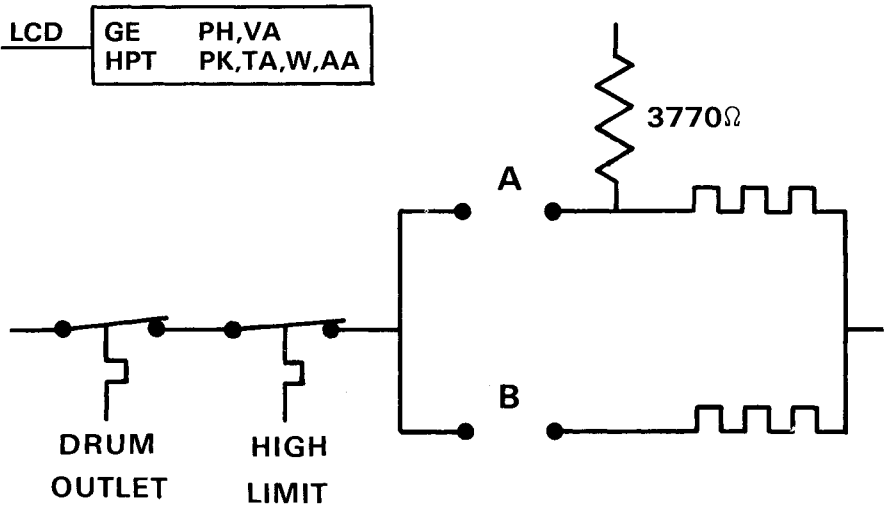
### 3. DELICATE & POLYSTER KNIT (Low Heat)

Selector switches A and C are closed. Both heaters operate initially until the low drum outlet thermostat opens. Then, the remaining heater is cycled by the high drum outlet. The timer runs only when the high drum outlet is open and also during the cooldown period.

(LCD), (LLCD)

## AUTOMATIC TEMPERATURE CONTROL (ATC) MODELS

Basic Timer Operation - See Page Q - 2



### 1. COTTONS, DENIMS, PERMANENT PRESS, POLYKNITS, NORMAL (High Heat)

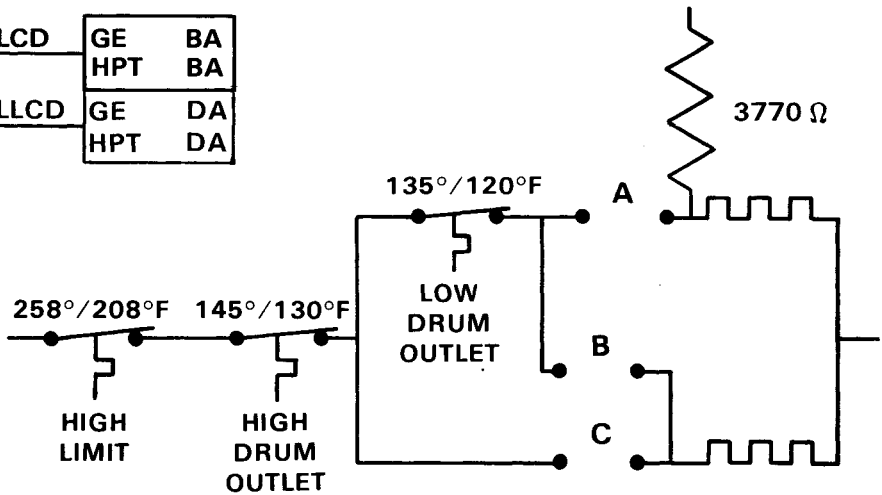
Selector switches A & B are closed. Both heaters operate and are cycled by the drum outlet thermostat. The timer runs only when the thermostat is open and also during the cooldown period.

### 2. DELICATE (Low Heat)

Only selector switch B is closed. Only one heater operates and is cycled by the drum outlet thermostat. The timer runs constantly because this cycle is used only with the TIMED setting.

# CYCLES & CONTROL SYSTEMS

LCD	GE	BA
	HPT	BA
LLCD	GE	DA
	HPT	DA



## 1. NORMAL (High Heat)

Selector switches A, B, & C are closed. Both heaters operate and are cycled by the high drum outlet thermostat. The low drum outlet opens and stays open with no effect. The timer runs only when the high drum outlet is open and during the cooldown period.

## 2. PERMANENT PRESS (Medium Heat)

Selector switches A & B are closed. Both heaters operate and are cycled by the low drum outlet thermostat. The timer runs only when the thermostat is open and also during the cooldown period.

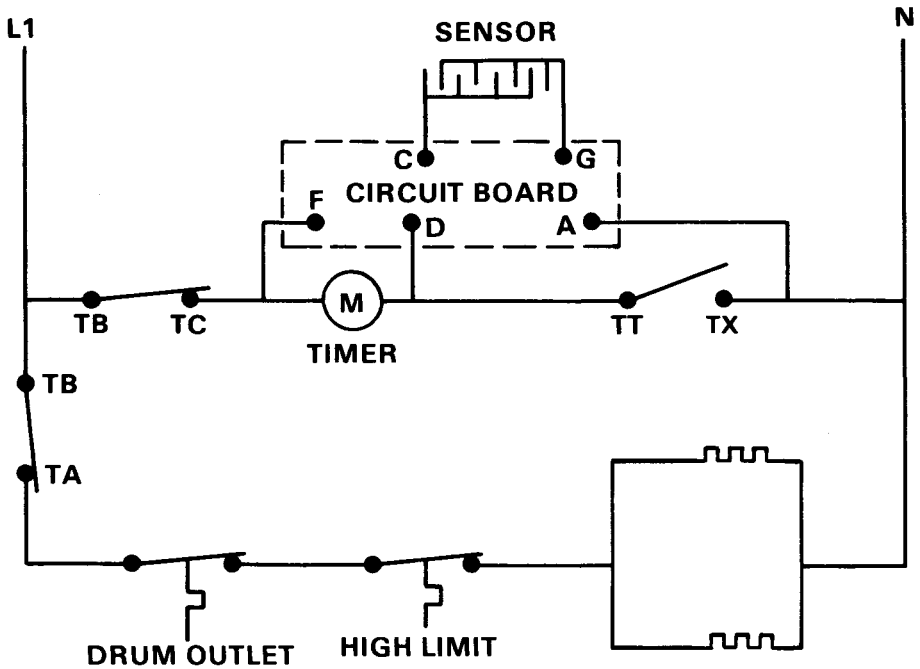
## 3. DELICATE, POLYKNITS (Low Heat)

Selector switches A & C are closed. Both heaters operate initially until the low drum outlet thermostat opens. The remaining heater is cycled by the high drum outlet. The timer runs only when the high drum outlet is open and also during the cooldown period.

## ELECTRIC DRYER - LCD, LLCD ELECTRONIC SENSOR CONTROL

### Basic Timer Operation

When the dial pointer is set for a SENSOR selection, timer operation is controlled by the sensor and circuit board. When the sensor starts to feel a dry load the circuit board supplies sufficient voltage to the timer motor to make it run. As the fabric load reaches the selected level of dryness, timer contacts TB - TA open and TT - TX close. This provides a cooldown period at the end of the cycle. As on the TIMED ONLY models the thermostats cycle the heater and have no effect on timer operation. See HEAT SYSTEMS & CONTROL for detailed explanation of operation.

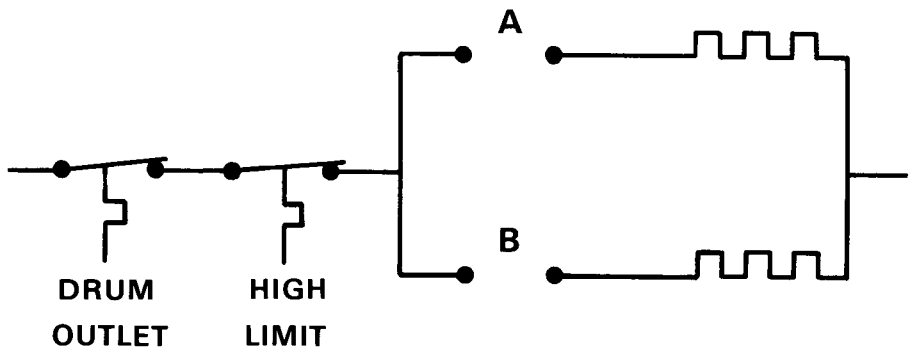


SIMPLIFIED SCHEMATIC



# CYCLES & CONTROL SYSTEMS

LCD    GE    VA

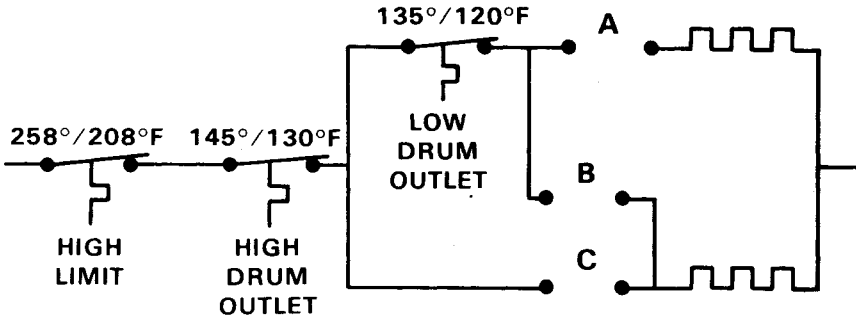
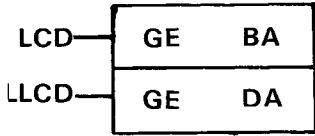


## 1. NORMAL, PERMANENT PRESS, POLYKNIT (High Heat)

Selector switches A & B are closed. Both heaters operate and are cycled by the drum outlet thermostat. The timer runs only when the sensor (in the drum) feels dry clothes and also during the cooldown period.

## 2. DELICATE (Low Heat)

Only selector switch B is closed. Only one heater operates and is cycled by the drum outlet thermostat. The timer runs continuously because this cycle is normally used only with the TIMED setting. However, the sensor cycle CAN be used with delicates by setting the timer dial to KNITS.



## 1. NORMAL (High Heat)

Selector switches A, B, & C are closed. Both heaters operate and are cycled by the high drum outlet thermostat. The low drum outlet opens and stays open with no effect. The timer runs only when the sensor (in the drum) feels dry clothes and also during the "cooldown" period.

## 2. PERMANENT PRESS (Medium Heat)

Selector switches A & B are closed. Both heaters operate and are cycled by the low drum outlet thermostat. The timer runs only when the sensor (in the drum) feels dry clothes and also during the "cooldown" period.

## 3. DELICATE, POLYKNITS (Low Heat)

Selector switches A & C are closed. Both heaters operate initially until the low drum outlet thermostat opens. The remaining heater is cycled by the high drum outlet. The timer runs only when the sensor (in the drum) feels dry clothes and also during the "cooldown" period.

# CYCLES & CONTROL SYSTEMS

## GAS DRYERS TIMED CYCLE MODELS

### Basic Timer Operation

When TIMED drying is selected, the drying time in minutes is set on the timer dial. The fabric type or temperature is set with the selector switch. Actuating the start switch starts the dryer and timer operation begins, as shown in the simplified circuit below.

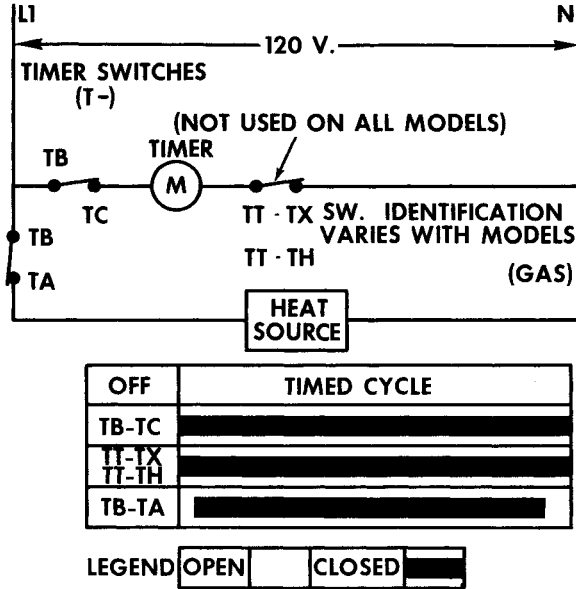


Figure 1 — Simplified Schematic

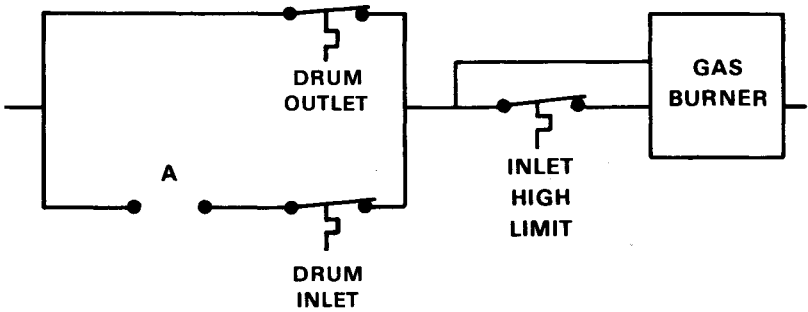
If the timer dial is not in an OFF zone, Switches TB - TC & TT - TX are closed. Drying temperature is controlled by the thermostat system.

### Fluff Cycle - All Models

All selector switches to the gas burner are open. The dryer tumbles without heat for the number of minutes selected on the timer. Timed cycle only.

SCD, LLCD  
TIMED CYCLE MODELS

SCD GE VA



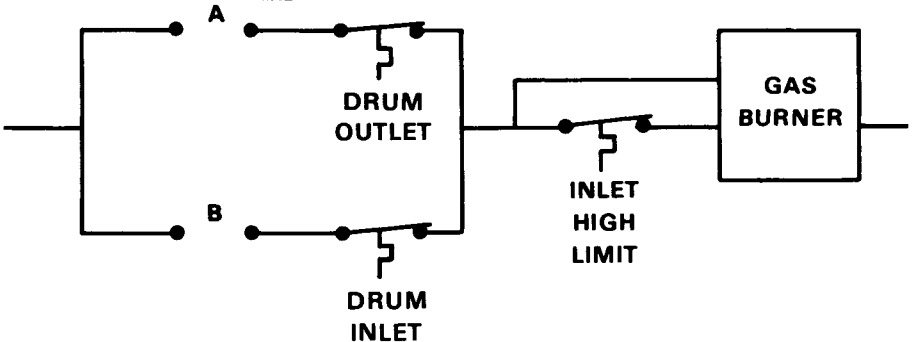
1. NORMAL (High Heat)

Selector switch A is closed. The drum inlet thermostat opens first and then the drum outlet. The gas burner is cycled by the drum inlet. The timer runs continuously.

2. DELICATE (Low Heat)

Selector switch A is open. The gas burner is cycled by the drum outlet thermostat. The timer runs continuously.

SCD GE VA  
HPT PH,AA



1. NORMAL (High Heat)

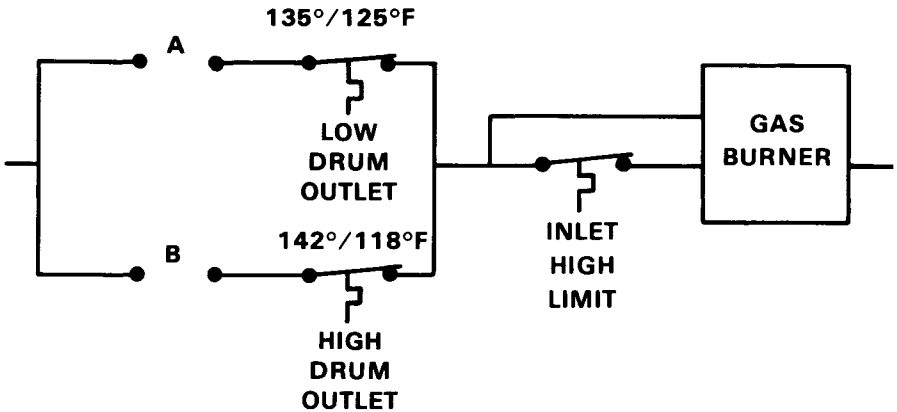
Both selector switches A & B are closed. The drum inlet thermostat opens first and then the drum outlet. The gas burner is cycled by the drum inlet. The timer runs continuously.

# CYCLES & CONTROL SYSTEMS

## 2. DELICATE (Low Heat)

Only selector switch A is closed. The gas burner is cycled by the drum outlet thermostat. The timer runs continuously.

SCD	GE	BA
	HPT	BA
LLCD	GE	DA
	HPT	DA



## 1. COTTONS, DURABLES, PERMANENT PRESS (Normal)

Both selector switches A & B are closed. The low drum outlet thermostat opens first and then the high drum outlet. The gas burner is cycled by the low drum outlet after the first high drum outlet trip. The timer runs continuously.

## 2. DELICATE & KNITS

Only selector switch A is closed. The gas burner is cycled by the low drum outlet thermostat (in the trap duct). The timer runs continuously.

**GAS DRYERS**

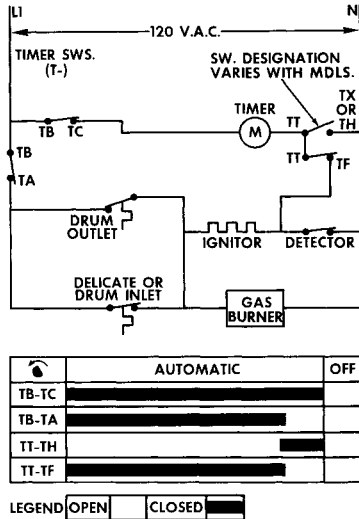
**AUTOMATIC TEMPERATURE CONTROL (ATC) MODELS**

**Basic Timer Operation**

GE - V Models & Earlier

HPT - A Models & Earlier

When automatic drying is selected, the timer dial is set in the automatic zone. The fabric type or temperature is set on the selector switch. Actuating the safety start switch starts the dryer.



**Figure 4 — Simplified Schematic**

120 Volts is applied to the Gas valve coils and drying begins. The drum inlet thermostat (Standard Capacity) or Delicate Thermostat (Large Capacity) located near the combustion chamber is the first to open. The gas valve REMAINS energized through the drum outlet thermostat, which has not yet reached its trip temperature. As the clothes load begins to dry, the drum outlet thermostat trips turning the gas burner OFF. No timer operation has occurred to this point. Turning the gas burner OFF removes the source of heat that has been holding the detector OPEN. In approximately 30 seconds, the detector cools and closes, providing a circuit through TT - TF to operate the timer motor. When the dryer cools down, as a result of moisture in the clothes load, the drum inlet or delicate thermostat will reset. The ignitor and gas burner are energized; the detector opens stopping timer operation and another heat cycle begins. This alternate heat cycle and timer run cycle continues until approximately 8 minutes before the OFF zone. As the OFF zone is approached, timer switch TT - TH will close providing constant timer operation, and timer switch TB - TA will open establishing the cool down period of approximately 8 minutes.

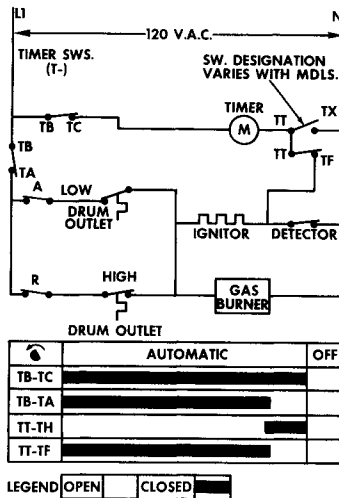
# CYCLES & CONTROL SYSTEMS

## BASIC TIMER OPERATION

### GE & HPT - B Models & Later

The drum inlet T'stat (SCD) and the blower T'stat (LCD) have been eliminated on the B models. A low drum outlet T'stat has been added to the SCD & LLCD trap duct. The LCD delicate T'stat has been replaced by a low drum outlet T'stat still located on the internal exhaust duct. These new T'stats are the same for the SCD, LLCD & LCD.

When automatic drying is selected, the timer dial is set in the automatic zone. The fabric type & temperature is set on the selector switch. Actuating the safety start switch starts the dryer.



**Figure 4A - Simplified Schematic**

120 volts is applied to the gas valve coils. The low drum outlet T'stat opens first. Depending on the setting of the selector switches the burner may or may not go off. If it does not go off then the temperature will be controlled by the high drum outlet T'stat thru the first burn. Again, depending on the selector switches either the Low or High drum outlet T'stat will control the temperature during the rest of the cycle.

As the clothes load begins to dry, the drum outlet thermostat trips turning the gas burner OFF. No timer operation has occurred to this point. Turning the gas burner OFF removes the source of heat that has been holding the detector OPEN. In approximately 30 seconds, the detector cools and closes, providing a circuit through TT - TF to operate the timer motor. When the dryer cools down, as a result of moisture in the clothes load, the drum outlet thermostat will reset. The ignitor and gas burner are energized; the detector

# CYCLES & CONTROL SYSTEMS

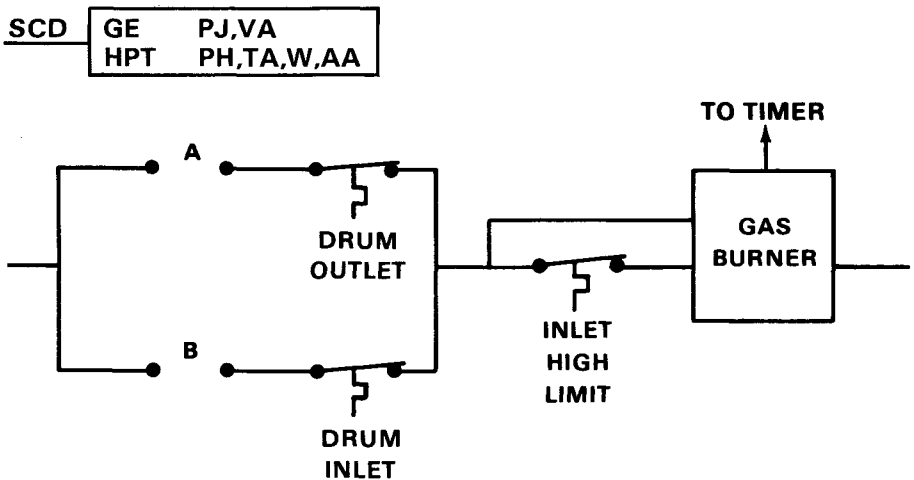
opens stopping timer operation and another heat cycle begins. This alternate heat cycle and timer run cycle continues until approximately 8 minutes before the OFF zone. As the OFF zone is approached, timer switch TT - TH will close providing constant timer operation, and timer switch TB - TA will open establishing the cooldown period of approximately 8 minutes.

## Fluff Cycle - All Models

All selector switches to the gas burner are open. The dryer tumbles without heat for the number of minutes selected on the timer. Timed cycle only.

## SCD

### AUTOMATIC TEMPERATURE CONTROL (ATC) MODELS



#### 1. NORMAL, PERMANENT PRESS, POLYKNITS (High Heat)

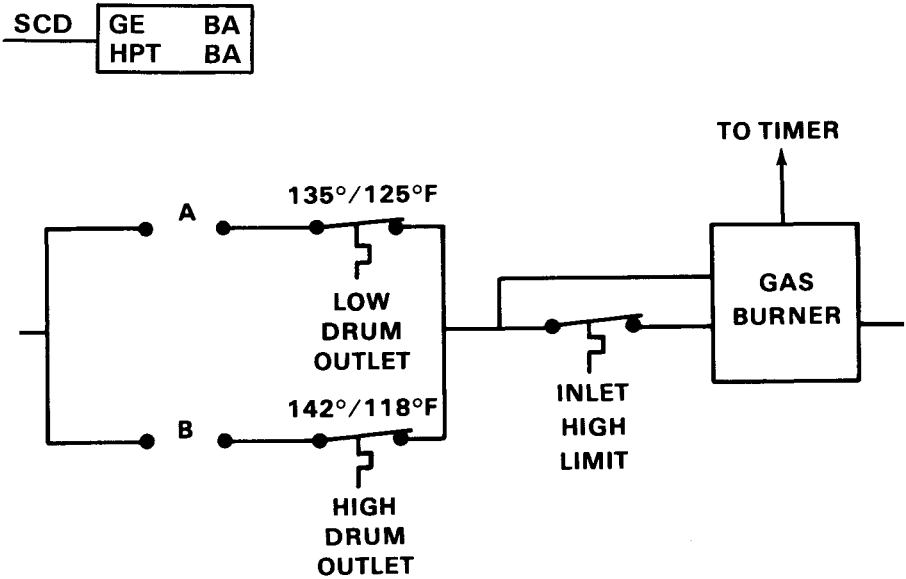
Both Selector switches A & B are closed. The drum inlet thermostats opens first and then the drum outlet. The gas burner is cycled by the drum inlet after the first drum outlet trip. The timer runs only when both thermostats are open and during the cooldown period.

#### 2. DELICATE (Low Heat)

Only selector switch A is closed. The gas burner is cycled by the drum outlet thermostat. The timer runs continuously because this cycle is used with the TIMED setting only.



# CYCLES & CONTROL SYSTEMS



## 1. COTTONS, DURABLES, NORMAL (High Heat)

Only selector switch B is closed. The gas burner is cycled by the high drum outlet thermostat. The timer runs only when the thermostat is open and during the cooldown period.

## 2. PERMANENT PRESS (Medium Heat)

Both selector switches A & B are closed. The low drum outlet thermostat opens first and then the high drum outlet. The gas burner is cycled by the low drum outlet after the first high drum outlet trip. The timer runs only when both thermostats are open and during the cooldown period.

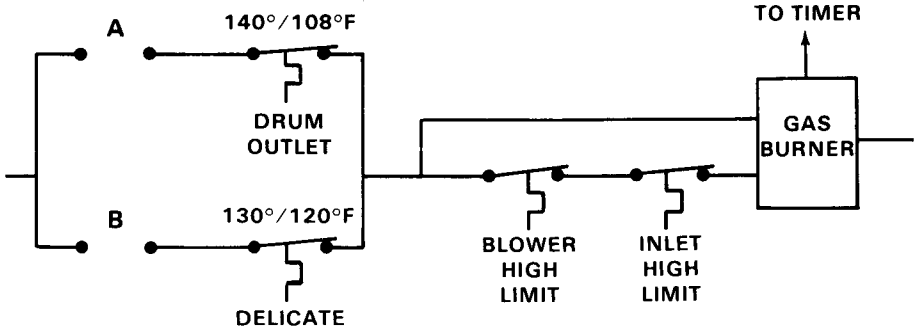
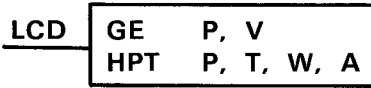
## 3. DELICATE (Low Heat)

Only selector switch A is closed. The gas burner is cycled by the low drum outlet thermostat. The timer runs only when the thermostat is open and during the cooldown period.

(LCD), (LLCD)

## AUTOMATIC TEMPERATURE CONTROL (ATC) MODELS

Basic Timer Operation - See Page Q - 16



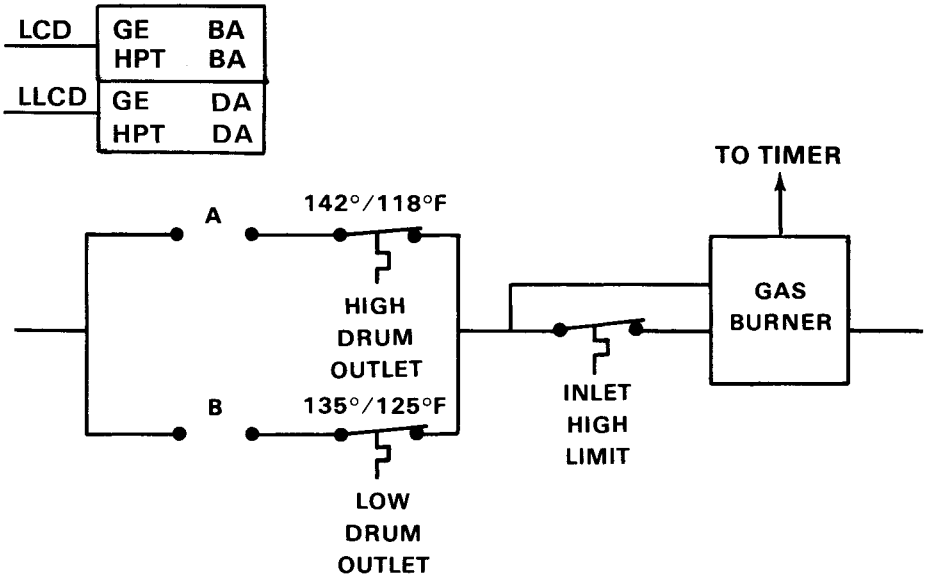
### 1. COTTONS, NORMAL, PERMANENT PRESS (High Heat)

Both selector switches A & B are closed. The delicate thermostat opens first and then the drum outlet. The gas burner is then cycled by the delicate thermostat. The timer runs only when both thermostats are open and during the cooldown period.

### 2. DELICATE (Low Heat)

Only selector switch B is closed. The gas burner is cycled by the delicate thermostat. The timer runs continuously because this cycle is used with the TIMED setting only.

# CYCLES & CONTROL SYSTEMS



## 1. COTTONS, NORMAL, DURABLES (High Heat)

Only selector switch A is closed. The gas burner is cycled by the high drum outlet thermostat. The timer runs only when the thermostat is open and during the cooldown period.

## 2. PERMANENT PRESS (Medium Heat)

Both selector switches A & B are closed. The low drum outlet thermostat opens first and then the high drum outlet. The gas burner is cycled by the low drum outlet after the first high drum outlet trip. The timer runs only when both thermostats are open and during the cool down period.

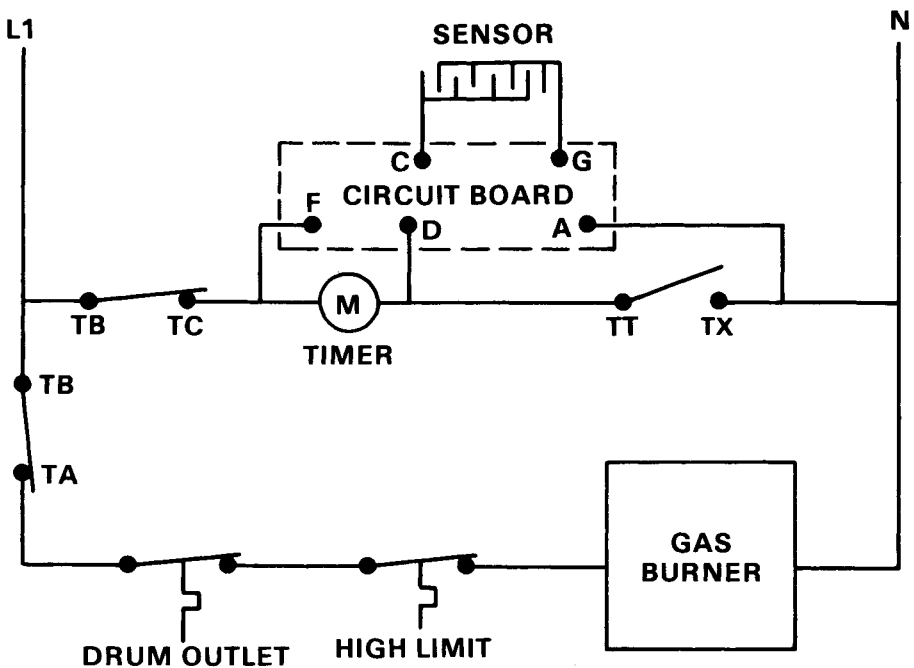
## 3. DELICATE (Low Heat)

Only selector switch B is closed. The gas burner is cycled by the low drum outlet thermostat. The timer runs only when the thermostat is open and during the cooldown period.

## GAS DRYER ELECTRONIC SENSOR CONTROL

### Basic Timer Operation

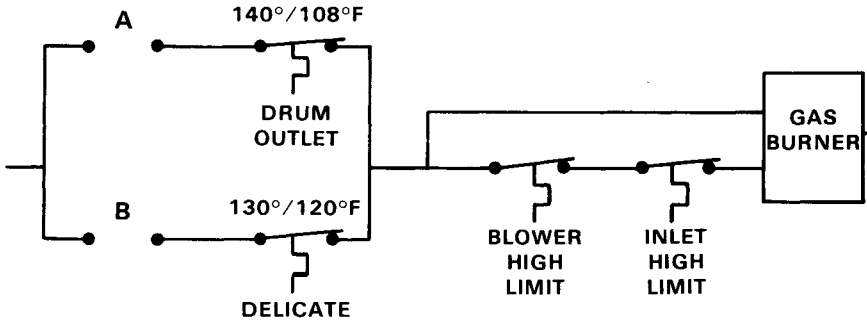
When the dial pointer is set for a sensor selection, timer operation is controlled by the sensor and circuit board. When the sensor starts to feel a dry load the circuit board supplies sufficient voltage to the timer motor to make it run. As the fabric load reaches the selected level of dryness, the timer has advanced to the point where timer contacts TB - TA open and TT - TX close. This provides a cooldown period at the end of the cycle. As on the TIMED ONLY models the thermostats cycle the gas burner and have no effect on timer operation. See HEAT SYSTEMS & CONTROL for detailed explanation of operation.



**SIMPLIFIED SCHEMATIC**

# CYCLES & CONTROL SYSTEMS

LCD GE VB



## 1. NORMAL, PERMANENT PRESS, POLYKNITS (High Heat)

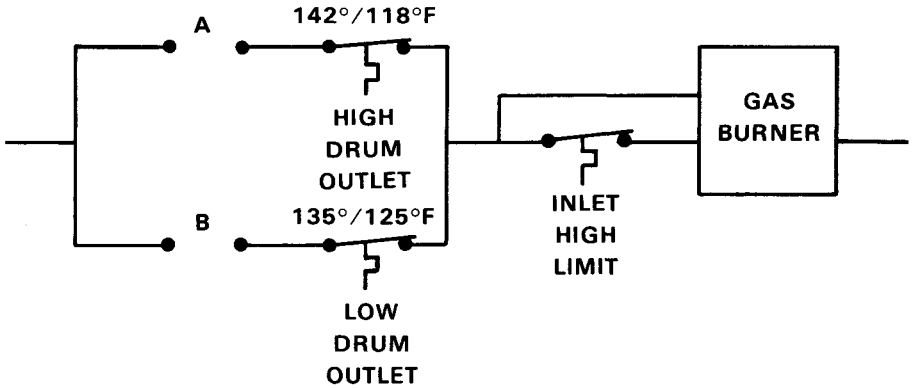
Both selector switches A & B are closed. The delicate thermostat opens first and then the drum outlet. The gas burner is then cycled by the delicate thermostat. The timer runs only when the sensor (in the drum) feels a dry load and also during the cooldown period.

## 2. DELICATE (Low Heat)

Only selector switch B is closed. The gas burner is cycled by the delicate thermostat. The timer runs continuously because this cycle is normally used with the TIMED setting only.\*

\*However, the SENSOR cycle can be used with delicates by setting the timer dial to KNITS

LCD	GE BA
LLCD	GE DA



## 1. NORMAL, COTTONS (High Heat)

Only selector switch A is closed. The gas burner is cycled by the high drum outlet thermostat. The timer runs only when the sensor (in the drum) feels a dry load and also during the cooldown period.

## 2. PERMANENT PRESS (Medium Heat)

Both selector switches A & B are closed. The low drum outlet thermostat opens first and then the high drum outlet. The gas burner is cycled by the low drum outlet after the first high drum outlet trip. The timer runs only when the sensor (in the drum) feels a dry load and also during the cooldown period.

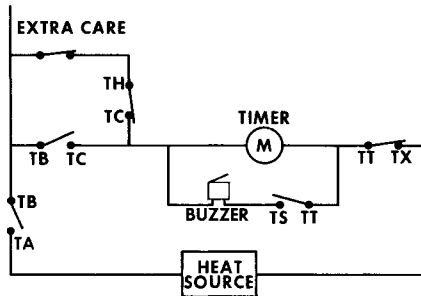
## 3. DELICATE (Low Heat)

Only selector switch B is closed. The gas burner is cycled by the low drum outlet thermostat. The timer runs only when the sensor (in the drum) feels a dry load and also during the cooldown period.

# CYCLES & CONTROL SYSTEMS

## EXTRA CARE

Extra Care, is available following some of the automatic cycles. If Extra Care is selected (Extra Care switch closed), the timer will advance for an additional 15 minutes. During this time, the clothes tumble without heat, and the mechanical end-of-cycle buzzer sounds periodically indicating the load should be removed. See the simplified cam chart and schematic below.



TIMER CAM CHART

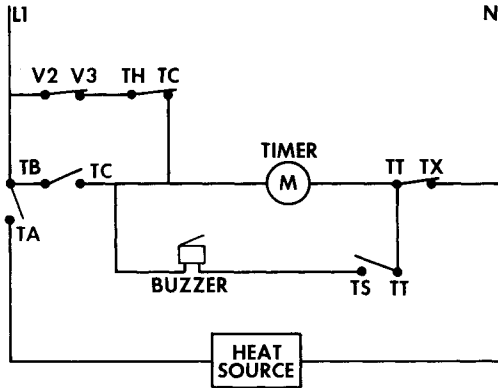
	OFF	AUTO. P.P. & COTTONS	EXTRA CARE	TIMED CYCLE	OFF	AUTO. POLY KNIT CYCLE	EXTRA CARE
TB-TA	■	■		■		■	
TB-TC	■	■		■		■	
TT-TX	■		■	■		■	■
TH-TC			■				■
TT-TS	■		■	■		■	■


**Figure 5 — Simplified Schematic**

The first indicated OFF zone is the end of the cycle, if Extra Care is selected. If Extra Care is NOT selected the dryer stops at the end of the automatic cycle selected.

PRESS-GUARD CYCLE — GAS/ELECTRIC MODELS

When the PRESS-GUARD cycle is selected, the press-guard is set ON and the timer dial is set in the AUTO SENSI-DRY zone. Operation of the dryer in the AUTO SENSI-DRY zone is explained under CYCLES-AUTOMATIC. Near the end of the AUTO SENSI-DRY cycle, timer switch TH - TC closes. Refer to the simplified schematic and cam chart below.



	AUTO SENSI-DRY	PRESS GUARD	On
TH-TC		████████████████████	
TT-TX	████████████████████	████████████████████	
TB-TC	████████████████████		
TB-TA	████████████████████		
TT-TS			

**Figure 6 — Simplified Schematic**

Timer switches TT - TX and TH - TC are closed as well as the PRESS-GUARD switch V2 - V3, resulting in constant timer operation into the PRESS-GUARD zone. At the same time, timer switch TB - TA opens eliminating any further heat. As the timer progresses through the PRESS-GUARD zone, the drum continues to tumble, no heat, and timer switch TT makes to TS once each five minutes, energizing the end of cycle buzzer indicating the load should be removed.





## HEAT SYSTEMS & CONTROLS

### INDEX

	PAGE
ELECTRONIC SENSOR	R - 20
GLO-BAR IGNITOR	R - 8
HEAT SYSTEM - ELECTRIC	R - 2
HEAT SYSTEM - GAS	R - 4
THERMOSTATS - ELECTRIC - SCD, LLCD	R - 15
- LCD	R - 17
- LLCD	R - 19
THERMOSTATS - GAS - SCD	R - 10
- LCD	R - 12
- LLCD	R - 10

# HEAT SYSTEMS & CONTROLS

## ELECTRIC HEAT SYSTEM

Heat in electric dryers is produced by two identical coil heaters. These heaters are parallel connected and on some models are controlled by one or more selector switches allowing a selection of HIGH HEAT (two heaters), LOW HEAT (one heater), or FLUFF (both heaters switched out of the circuit).

Refer to the simplified circuit below, Figure 1.

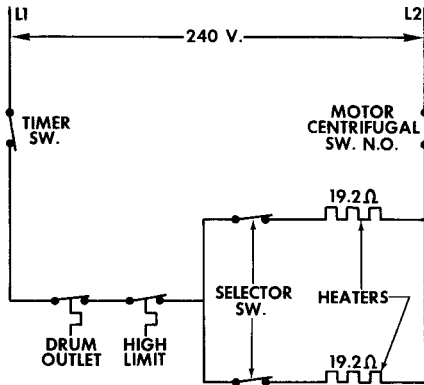


Figure 1

The heater circuit is wired with the timer switch on one side of the line and the motor centrifugal switch on the alternate side of the line. The number of heaters energized is determined by the selector switch. The ON/OFF heater cycling is normally controlled by the drum outlet thermostat. The high limit thermostat will cycle the heaters in the event of inadequate air flow.

Refer to Mini-Manual for the complete schematic for your specific model. Mini-Manual is inside backslash.

HEATER REPLACEMENT — For cabinet disassembly, see CABINET CONSTRUCTION, Section T.

### SCD, LCD

1. Cut both ends of the defective coil at the terminals, Figure 2.
2. Cut the end(s) of the good coil at the common terminal(s), only.

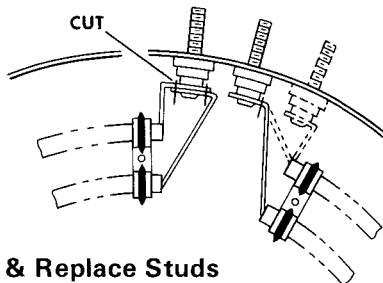
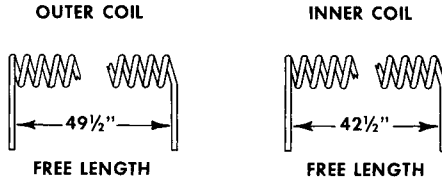


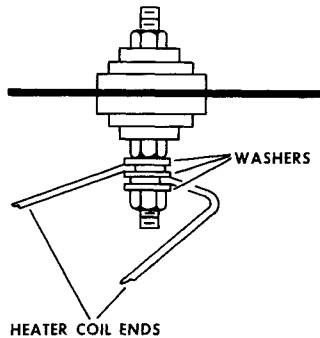
Figure 2 - Cut Coils & Replace Studs

3. Remove the two terminals from which the heater coils were cut and replace with the two new terminals from heater kit.
4. Stretch the replacement coil to the proper free length, Figure 3.



**Figure 3 - Stretch Replacement Coils.**

5. Remove the defective heater coil from the heater assembly and thread the replacement coil through the insulators, taking care to ensure that the coils are evenly spaced to prevent hot spots.
6. Make hooks on the ends of the coils and place the hooked ends on the proper terminal so that each hooked end is sandwiched between two washers, Figure 4.



**Figure 4 - Install Studs and Connect**

## **TO REPLACE BOTH HEATER COILS**

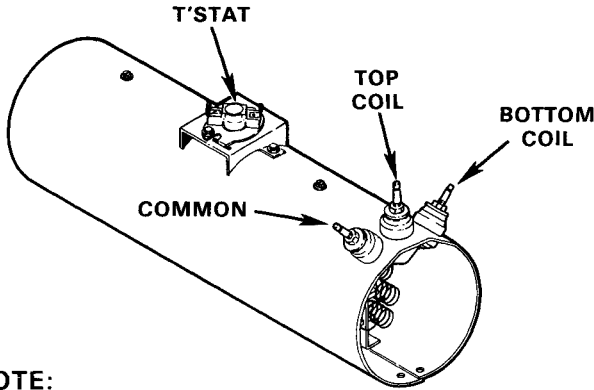
Two identical heater kits are needed when both coils are to be replaced. Follow previous instructions for each coil and discard the extra terminal assembly(s).

# HEAT SYSTEMS & CONTROLS

## LLCD

The coils and the cylindrical heater housing are replaced as a unit. First, raise the cover and remove the cabinet front and drum. Disconnect the wires from the 3 heater studs and the safety (Hi-limit) thermostat. Remove the 2 screws holding the housing to the dryer base. Pull the housing towards the front and up.

The thermostat and its mounting bracket are not part of the replacement heater. Remove the single screw holding the bracket to the housing and lift off the T'stat and bracket assembly.



## SERVICE NOTE:

Premature heater failure may be caused by improper air flow resulting from incomplete cabinet sealing or an inadequate exhaust system. See Drum Drive & Air Flow Section S.

## GAS VALVE – HEAT SYSTEM

### MAIN COMPONENTS

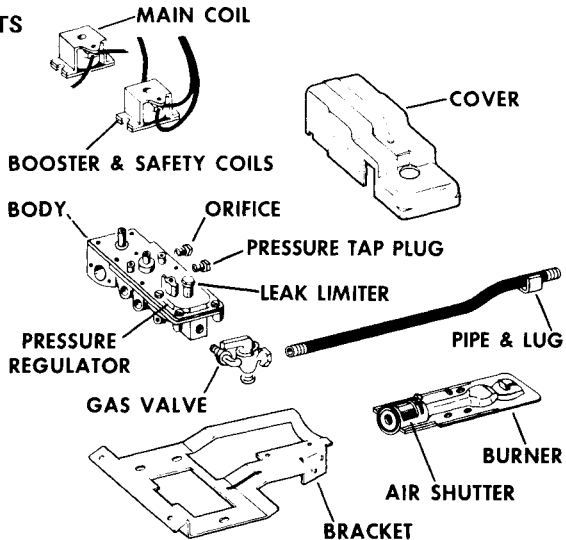
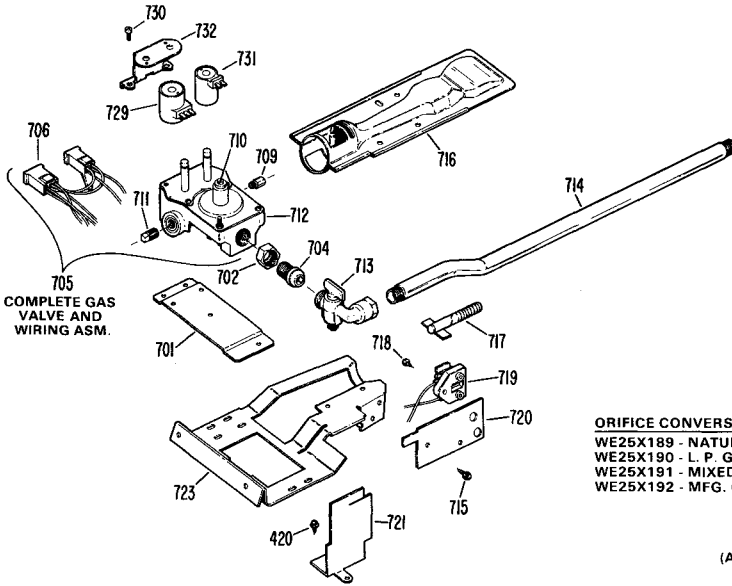


Figure 5

# HEAT SYSTEMS & CONTROLS

## GAS VALVE & BURNER ASSEMBLY



(ART NO. WE7302)

REF. NO.	PART NUMBER	PART DESCRIPTION
702	WE13X0166	Bkt. Gas Valve
702	WE02X0319	Nut Gas Valve
704	WE02X0320	Nipple Gas Valve
705	WE14X0171	Valve & Harness Asm.
706	No Part No.	Not Stocked
709	WE01X0968	Orifice (69-2043)
710	WE01X1076	Leak Limiter
711	1/8-27NPT	Pipe Plug (Not Stocked)
712	No Part No.	Not Stocked
713	WE01X1078	Valve Shutoff
714	WE01X1077	Pipe & Lug Asm.
715	WD02X5063	SCR 8-18 PH HX 13/32 S
716	WE01X1068	Burner Asm.
717	WE04X0444	Ignitor
718	WZ04X0220	SCR 6-20 AB HXW 1/2 S
719	WE01X1075	Spring & Lead Asm.
720	WE13X0116	Bkt. Igniter
721	WE13X0118	Bkt. Spacer
723	WE13X0117	Bkt. Valve
729	WE04X0692	Dual Coil
730	WE02X0333	Screw
731	WE04X0693	Main Coil
732	WE13X0169	Bkt. (Coil)

# HEAT SYSTEMS & CONTROLS

## GAS FLOW (Typical Valve)

Gas flows from the supply line through the shut-off valve and enters the left side of the valve body assembly. The gas pressure is reduced to 3.5 inches W.C. (water column), as it flows through the pressure regulator. The flow continues up to the safety valve, but cannot pass through until the safety solenoid is energized, Figure 6.

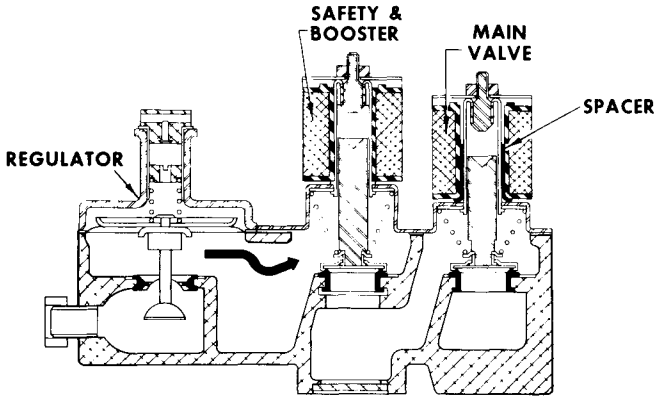


Figure 6

When the safety valve solenoid is energized, the plunger is raised and allows gas to glow up to the main valve, Figure 7

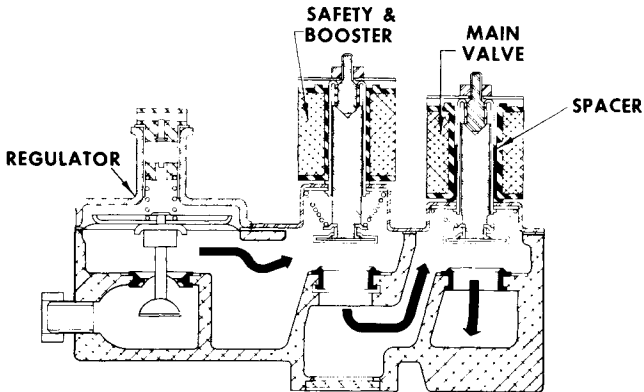


Figure 7

After the main valve solenoid is energized, its plunger is raised and gas flows through the main valve and out the right side of the valve body, Figure 8. It then passes through the main burner orifice, through the burner, and is ignited by the Glo-bar. For glo-bar operation, See Glo-Bar Ignitor Page R-7.

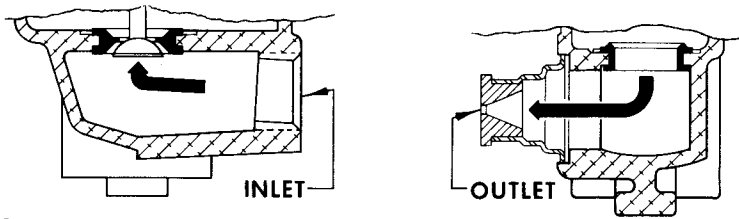


Figure 8

## LEAK LIMITER

The leak limiter is screwed into the top of the pressure regulator. It lets atmospheric pressure into the regulator. If the diaphragm in the regulator should rupture, the leak limiter restricts the escaping gas to a maximum of one cubic foot per hour.

## ADJUSTMENTS

1. Pressure regulator test:
  - a. Shut off gas valve.
  - b. Remove pressure tap plug with 7/16" wrench and screw in manometer (WX5X132).
  - c. Turn on gas valve.
  - d. Set control to 20 minutes or longer and start dryer.
  - e. Read W.C. (water column) pressure with main burner on. 3.4 - 3.6 inches is satisfactory. If pressure is out of range, remove leak limiter and recheck.
    1. If pressure is within range, install new leak limiter.
    2. If pressure is still not within specification, the pressure regulator should be adjusted to 3.5 inches with main burner on. Adjustment screw is located under the leak limiter.
    3. If pressure still cannot be adjusted to specification, replace valve body.
  - f. Be sure to reinstall pressure tap plug and test connections with bubble solution.
2. Main burner orifice size (Drill No.) is stamped on hex part of orifice.



# HEAT SYSTEMS & CONTROLS

## FOR MODELS WITH AIR SHUTTER –

3. To adjust the main burner flame:

- a. Start main burner.
- b. Loosen air shutter lock screw.
- c. Close air shutter; then open slowly until the yellow tips just disappear.
- d. Flame should not “lift” or blow away from burner.
- e. Tighten air shutter lock screw.

**NOTE:** In many cases, the yellow tips will not disappear completely. Open the air shutter until the yellow tips are smallest; do not open shutter any further.

To replace the main valve solenoid, safety solenoid or booster valve solenoid –

- a. Disconnect solenoid leads from group of wires.
- b. Remove only one coil at a time because they are not interchangeable.
- c. When replacing the coils, be sure the rubber O ring is seated on the plunger guide under the metal base plate, Figure 9.

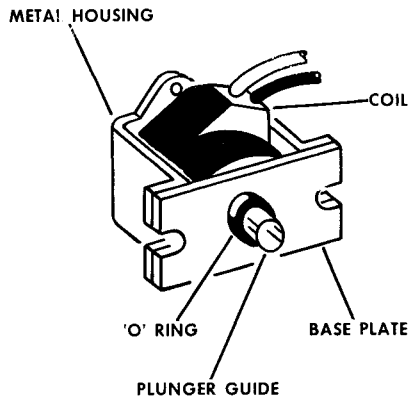


Figure 9

## BURNER ASM. REMOVAL

1. Unplug cordset from receptacle.
2. Remove front access plate.
3. Turn off the gas.
4. Disconnect the union.
5. Disconnect 2 wires from detector.
6. Disconnect block at coils.
7. Remove 2 mounting screws - Bracket to cabinet front.
8. Lift out valve.

## ALL GAS – GLO-BAR IGNITOR

### GLO-BAR IGNITOR CIRCUIT OPERATION

The system is made up of the following components: a gas valve with safety and main valves, glo-bar ignitor, and a detector. The safety valve is actuated by a double coil (the safety and booster coil). Both coils are needed to open the safety valve. Once energized, the safety coil alone will hold the valve open. The main valve has a single coil.

The flame detector is mounted on the combustion chamber. It is normally closed and will open –

1. By radiated heat from the glo-bar.
2. Will remain open by radiated heat from the gas flame.

### CIRCUIT OPERATION

When the dryer control system calls for heat, three circuits are energized, Figure 10.

1. N – through detector, ignitor, and thermostat to L1.
2. N – through detector, booster coil and thermostat to L1.
3. N – through safety coil and thermostats to L1.

# HEAT SYSTEMS & CONTROLS

The glo-bar is heating and the booster and safety coils both being energized have opened the safety valve. The main valve is closed, as its coil is bypassed by the N.C. flame detector. When the glo-bar reaches ignition temperature, approximately 60 seconds or less, the flame detector is heated and opens. This places the main coil in series with the glo-bar. The main valve opens and combustion occurs. The main coil now in series with the glo-bar causes the glo-bar to cool down. However, the flame detector is held open by radiant heat from the gas flame. The booster coil is now also in series with the main coil and is essentially inoperative. Should a momentary power failure occur, the gas valve will shut off and an attempt to restart will not occur until the flame detector cools and resets, approximately 30 seconds.

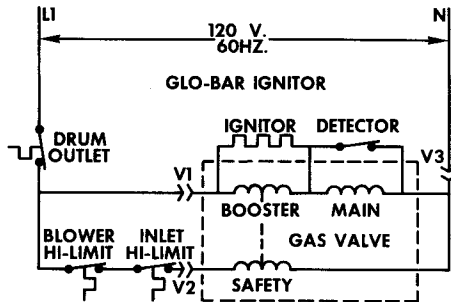


Figure 10

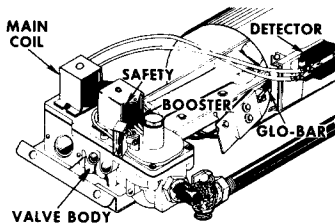


Figure 11

For gas valve test, see Gas Valve - Adjustments, Page R - 6.

## GLO-BAR Replacement

1. Remove complete valve from dryer.
2. Spread clip holding Glo-Bar ignitor. (Try Truarc Pliers)
3. Carefully replace ignitor.
4. Replace valve in dryer.

NOTE: It may be necessary to remove the ignitor clip from the valve assembly first.

## THERMOSTATS - SCD, LLCD

For proper thermostat operation, normal air flow must be maintained. Check—

- Exhaust system, type hood, duct length and number of elbows.
- Drum and blower seals, felt, etc.
- Cabinet sealing, trap duct permagum.
- Door Latch Pin

Consult AIR FLOW, Section S, for specific data.

### THERMOSTAT LOCATION

NOTE: Not all T'stats shown are used on all models. Check schematic on Mini-Manual for actual usage.

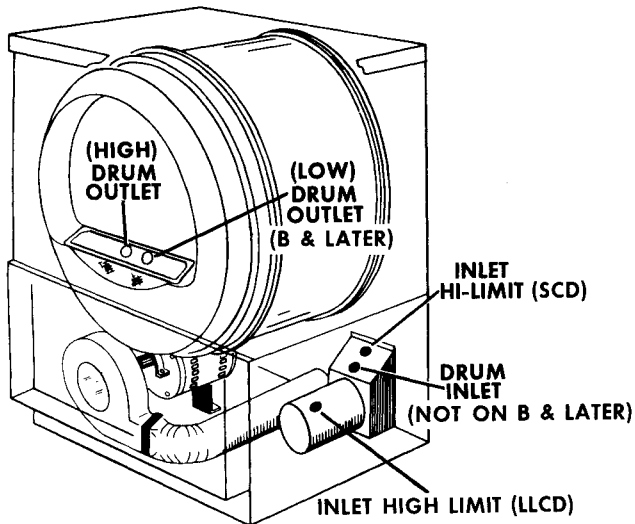


Figure 12

### THERMOSTAT FUNCTIONS

The drum outlet thermostats are the normal cycling, or "ON" "OFF" gas valve control.

The inlet hi-limit thermostat will cycle the gas valve in the event of over-temperature or improper or restricted air flow.

# HEAT SYSTEMS & CONTROLS

## THERMOSTAT TEST

### INLET HIGH LIMIT THERMOSTAT TEST

1. Operate dryer from a cold start, no load, timer and heat selector switch set for High Heat.
2. With door open, depress door switch and start dryer.
3. Measure the time, in seconds, from burner ignition until burner cycles off.
4. SCD - Time to cycle the burner off should be no more than 90 seconds.
5. LLCD - Time to cycle the burner off should be no more than 35 seconds.

### DRUM OUTLET CONTROL THERMOSTATS TEST (HI & LO)

1. Disconnect duct from rear of dryer such that air flow is unrestricted.
2. Place Tester WX5X138 Temperature Probe in the bottom center of Lint Trap.
3. Operate dryer from a Cold Start, Door closed, no load, with timer and heater selector switch set for Low Heat.
4. The temperature reading for the second heat cycle should not exceed 225°F. The temperature reading when the heat first cycles back on should be no less than 80°F.

NOTE: The temperature ranges shown in step 4 & 5 are broad enough to include all drum outlet T'stats-both HI & LO.

5. LLCD - The temperature reading for the second heat cycle should not exceed 185°F. The temperature reading when the heat first cycles back on should be no less than 110°F.

### DRUM INLET CONTROL THERMOSTAT TEST (SCD ONLY)

1. Disconnect exhaust duct and block off or tape over 75% of the dryer exhaust opening to simulate a clothes load.

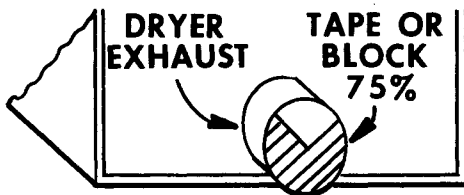


Figure 13

## HEAT SYSTEMS & CONTROLS

2. Unplug dryer from electric supply. Remove and tape one lead from the drum outlet control thermostat.
3. Place tester WX5X138 Temperature Probe in the bottom center of Lint Trap.
4. Operate dryer from Cold Start, door closed, no load, timer & heat selector switch set for High Heat.
5. The temperature reading for the second heat cycle should not exceed 225<sup>o</sup> F. The temperature reading when the heat first cycles back on should be no less than 90<sup>o</sup> F.
6. Unplug Dryer from electrical supply. Untape & reconnect lead going to drum outlet control T'stat.
7. Remove tape from exhaust when test is completed.

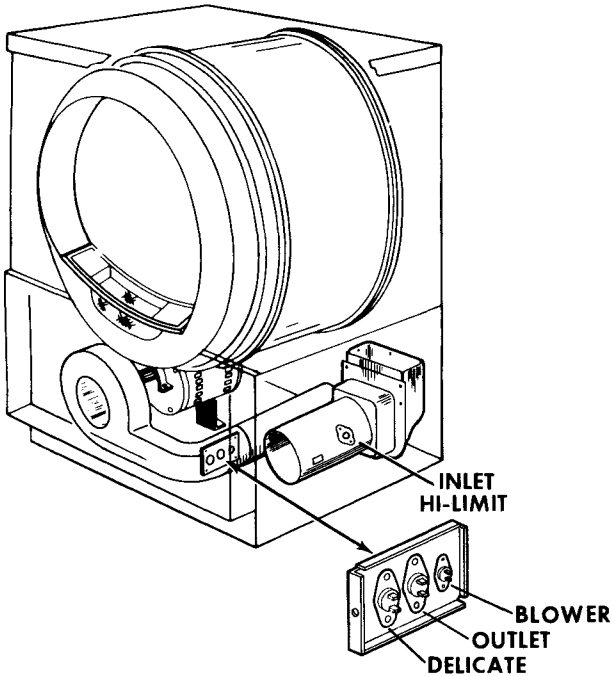
### THERMOSTATS LCD – GAS

For proper thermostat operation, normal air flow must be maintained. Check—

- Exhaust system, type hood, duct length, and number of elbows.
- Drum and blower seals, felt, etc.
- Cabinet sealing trap duct permagum.
- Door Latch Pin

Consult AIR FLOW, Section S, for specific data.

NOTE: Not all T'stats shown are used on all models. Check schematic on Mini-Manual for actual usage.



**Figure 14**

## THERMOSTAT FUNCTIONS

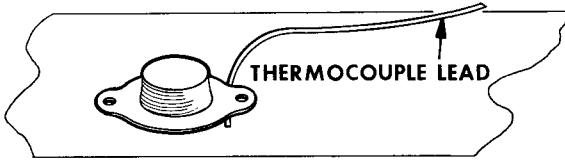
The drum outlet thermostat is the normal cycling, or "ON" - "OFF" gas valve control for high heat operation. The Delicate thermostat is the low heat control. The Inlet Hi-Limit and Blower housing thermostats will cycle the gas valve in the event of over-temperature or improper or restricted air flow.

## THERMOSTAT TEST

To test thermostats, you will need a voltmeter, test lamp or other voltage indicator and a temperature tester, WX5X138 equivalent.

## TEST SET-UP

1. Disconnect the temperature tester thermocouple lead from its alligator clip, if one is attached.
2. Mount the Thermocouple lead between one thermostat mounting ear and plate. See Figure 15.

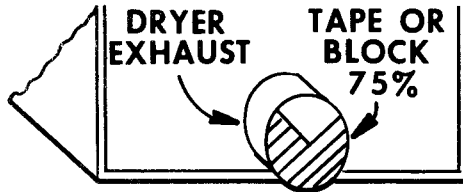


**Figure 15**

3. Connect the voltmeter across the thermostat terminals.

**NOTE:** In systems where the thermostats are connected in parallel, the thermostat NOT under test must be electrically isolated. Remove and tape one lead. See SCHEMATIC on Mini-Manual for specific model.

4. Disconnect exhaust duct and block off or tape over 75% of the dryer exhaust opening to simulate a clothes load, Figure 16.



**Figure 16**

## TESTING

1. Operate dryer, high heat, and observe voltmeter. A voltage reading indicates the thermostat HAS OPENED. No voltage reading indicates the thermostat is CLOSED.
2. Record the temperature at the third thermostat trip and compare with the chart below. Reading may vary  $\pm 10\%$ .
3. Remove tape from exhaust when test is completed.

FUNCTION	TEMP. DEGREES F. $\pm 10\%$	
	OPEN	CLOSE
(H I) DRUM OUTLET		
P THRU V	140°	108°
B	142°	118°
DELICATE (LO-DRUM)		
P THRU V	130°	120°
B	135°	125°
HI-LIMIT	335°	295°
BLOWER (NOT ON B)	150°	120°



# HEAT SYSTEMS & CONTROLS

## THERMOSTATS — SCD ELECTRIC

For proper thermostat operation, normal air flow must be maintained. Check —

- Exhaust system, type hood, duct length and number of elbows.
- Drum and blower seals, felt, etc.
- Cabinet sealing, trap duct permagum.
- Door Latch Pin

Consult AIR FLOW, Section S, for specific data.

### THERMOSTAT LOCATION

NOTE: Not all T'stats shown are used on all models. Check schematic on Mini-Manual for actual usage.

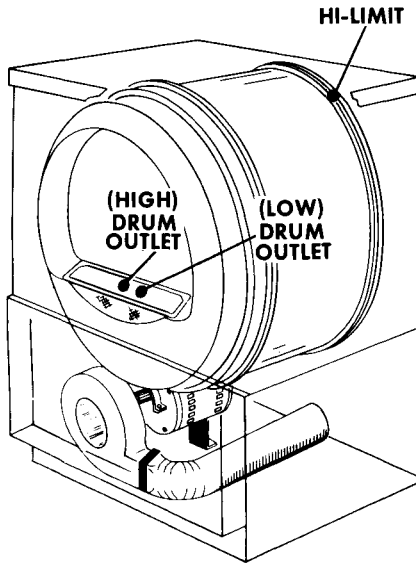


Figure 17

### HI-LIMIT THERMOSTAT TEST

The following test is performed on a cold dryer operating on a 240V supply.

1. No clothes load, timer and heat selector set for HIGH heat.
2. With the door open, depress door switch and start dryer.
3. Observe heaters at drum rear. Heaters should glow.
4. Measure the time, in seconds, from dryer start until you hear the safety ther-click off or observe the heaters begin to lose their bright red color.

ROOM TEMP. (° F)	TIME IN SECONDS TO TRIP
100	51-80
90	53-83
80	55-86
70	56-91
60	59-97
50	64-106

## DRUM OUTLET THERMOSTAT TEST

1. Disconnect exhaust system. Install WX5X138 oven tester in lint trap and operate closed dryer from a cold start. **NO CLOTHES LOAD.**

Late "P" thru "V" (GE)

"P" thru "A" (HPT)      (140°/120° F)

Late "V" (GE)

Late "A" (HPT)

All "B"

Hi-Drum Outlet (145°/130°)

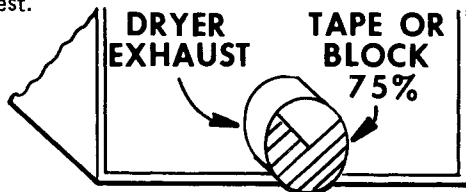
All conditions are the same as above.

Lo-Drum Outlet (130°/120°)

Conditions same as above except set Selector Switch for Permanent Press.

ROOM TEMP. (° F)	TRIP MAX.	RESET
60 °	160°-199°	83 °
70 °	164°-207°	86 °
80 °	171°-213°	93 °
90 °	178°-215°	98 °

2. If dryer is operated on 120V, 2 wire, block off 75% of the exhaust outlet for outlet thermostat test.



**Figure 18**

3. REMOVE TAPE FROM EXHAUST DUCT UPON COMPLETION OF TEST.

# HEAT SYSTEMS & CONTROLS

## THERMOSTATS LCD – ELECTRIC

For proper thermostat operation, normal air flow must be maintained. Check –

- Exhaust System - type hood, duct length, and number of elbows.
- Drum and Blower Seals-felt, etc.
- Cabinet Sealing - permagum.
- Door Latch Pin

Consult, AIR FLOW, Section S, for specific data.

NOTE: Not all T'stats shown are used on all models. Check schematic on Mini-Manual for actual usage.

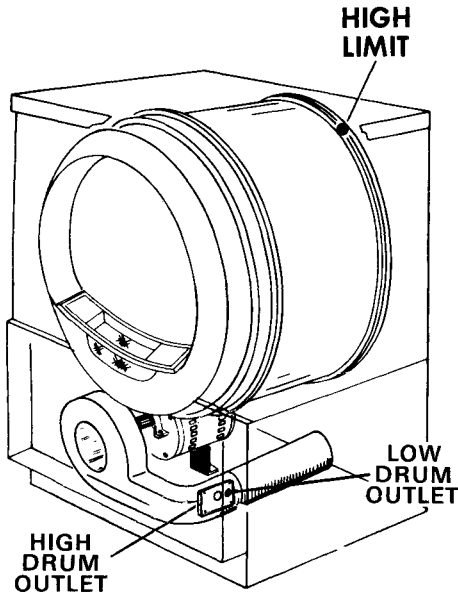


Figure 19

### HI-LIMIT THERMOSTAT – TEST

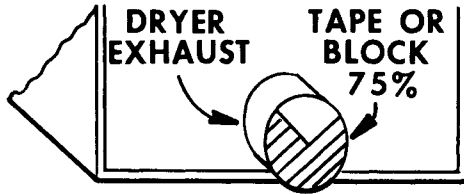
HI-LIMIT THERMOSTAT CHECK FOR DRYER INSTALLED ON 240V ONLY.

1. No clothes load, timer and heat selector set for HIGH heat.
2. With the door open, depress door switch and start dryer.
3. Observe heaters at drum rear. Heaters should glow.
4. Measure the time, in seconds, from dryer start until you hear the safety thermostat click off or observe the heaters begin to lose their bright red color.

ROOM TEMP. (° F)	TIME IN SECONDS TO TRIP
100	51-80
90	53-83
80	55-86
70	56-91
60	59-97
50	64-106

### DRUM OUTLET THERMOSTATS TEST (HI & LO-DELICATE)

1. Disconnect duct at rear of machine.
2. Block off or tape over 3/4 of exhaust outlet, Figure 20



**Figure 20**

3. Place temperature tester WX5X138 in the **BOTTOM CENTER** of lint trap.
4. Operate closed dryer from a cold start, **NO LOAD**, and compare readings to table below.
5. **REMOVE TAPE** from exhaust duct upon completion of test.

AMBIENT TEMP.	VOLTAGE	MAX. TEMP.
60°-90°	220V	225 °F.
60°-90°	225V	240 °F.
60°-90°	250V	260 °F.

# HEAT SYSTEMS & CONTROLS

## THERMOSTATS — LLCD ELECTRIC

For proper thermostat operation, normal air flow must be maintained. Check —

- Exhaust system, type hood, duct length and number of elbows.
- Drum and blower seals, felt, etc.
- Cabinet sealing, trap duct permagum.
- Door Latch Pin

Consult AIR FLOW, Section S, for specific data.

## THERMOSTAT LOCATION

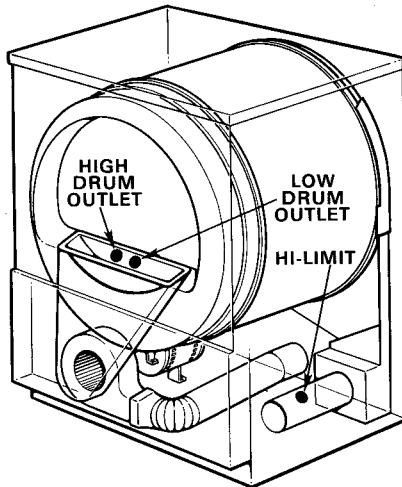


Figure 20A

## DRUM OUTLET THERMOSTATS TEST

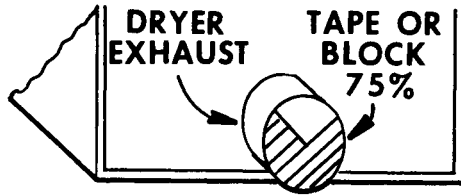
Disconnect exhaust system. Install WX5X138 oven tester in lint trap. Operate dryer from cold start. NO CLOTHES LOAD. Make separate tests for high and medium settings.

ROOM TEMP. (F°)	TRIP MAX.		RESET MIN.	
	MED*	HIGH**	MED	HIGH
60	170°	179°	110°	120°
70	172°	181°	110°	120°
80	175°	185°	110°	120°
90	175°	185°	110°	120°

\* Both heaters on. Controlled by low drum outlet T'stat

\*\* Both heaters on. Controlled by high drum outlet T'stat

If dryer is operated on 120V, 2 wire, block off 75% of the exhaust outlet for outlet thermostat test.



**Figure 20B**

## HI-LIMIT THERMOSTAT TEST

The following test is performed on a cold dryer operating on a 240V supply.

1. No clothes load, timer and heat selector set for HIGH heat.
2. With the door open, depress door switch and start dryer.
3. Measure the time, in seconds, from dryer start until you hear the safety thermostat click off.

ROOM TEMP. (°F)	TIME IN SECONDS TO TRIP - HI LIMIT
100	17-24
90	17-25
80	19-26
70	19-27
60	21-28
50	22-29

## ELECTRONIC SENSOR CONTROL — LCD, LLCD

### Operation

The electronic sensor control circuit senses clothes moisture and delays timer motor operation until a predetermined dryness is obtained.

# HEAT SYSTEMS & CONTROLS

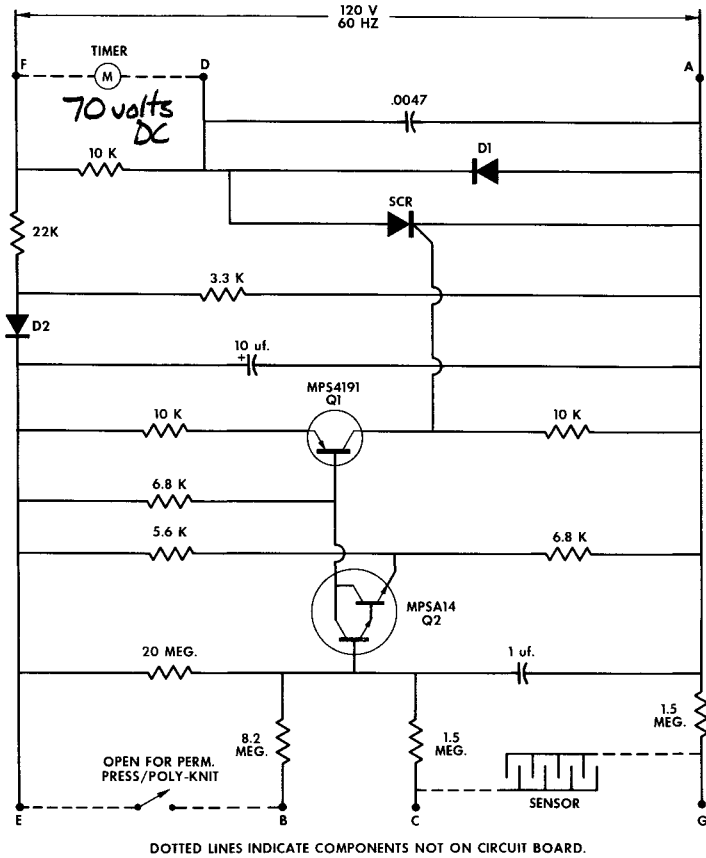


Figure 21

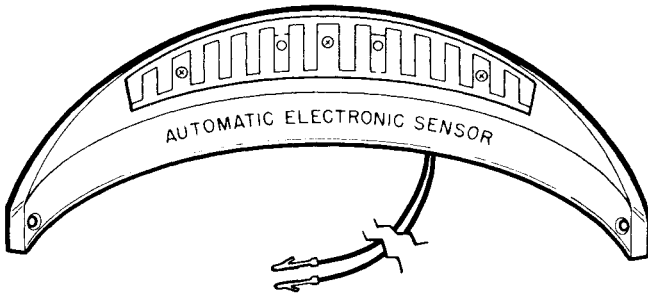
## Electronic Sensor Circuit Schematic

**WET LOAD:** With wet clothes contacting the sensor, the 1 uf capacitor cannot remain charged. Q2, Q1 and the SCR are not conducting and the timer motor is off or stalled.

**DRY LOAD:** With dry clothes contacting the sensor, its discharge action is reduced. The 1 uf capacitor is allowed to charge which turns on Q2, Q1 and the SCR. The SCR supplies the missing half wave of the A.C. wave to the timer motor and timer run-off begins. The 8.2 meg resistor and the 1 uf capacitor determine the turn-on point in the permanent press selection.

## CIRCUIT TEST PROCEDURE

1. Set your voltmeter on 150VAC or higher and connect across the timer motor. Push the permanent press button. Set the timer pointer to permanent press.
2. Conditions - No. load, ambient temperature 50° F to 105° F.
3. Open door, depress door switch by hand, and rotate start switch. Dryer should now be running.



**Figure 22 Sensor**

4. Short the sensor tracks to stop the timer motor. Meter should now read 75 volts or less. Remove short from sensor board and start counting seconds until voltmeter reads full line voltage and timer motor starts.

The tables below give the max./min. times for the motor to start after removing the short from the sensor.

905C513 G-8 Timer	Boards Temp Selector	Time to Energize Timer (Seconds)
Auto Cycle	NORM/HIGH	Max. 25
Permanent Press/ Poly Knit	Permanent Press/ Poly Knit	Min. 20 Max. 60

Times in excess of the maximum shown indicate a fault in the electronic system. A continuity check of the sensor leads and sensor tracks for both opens and shorts is necessary before assuming the fault is in the electronic circuit board.



# HEAT SYSTEMS & CONTROLS

## SENSOR CHECK

1. Turn dryer off and remove the wire leads from terminal C and G on the circuit board.
2. Connect an ohmmeter between the sensor wires from C and G. Resistance reading should be in excess of 1000 meg ohms.
3. Short across the sensor tracks. The resistance reading should drop to 10 ohms or less.
4. Connect ohmmeter between individual sensor wires and the dryer cabinet. Resistance reading should be 1000 meg ohms or more.
5. Check for cracks in sensor tracks by connecting ohmmeter from sensor wires to their respective tracks. Test at several points along tracks.
6. Check connection of wires to sensor.

## DRUM DRIVE & AIR FLOW

### INDEX

	PAGE
Air Flow & Seals - Gas	S - 4
Electric	S - 5
Drive System - SCD, LLCD	S - 16
- LCD	S - 19
Drum Support - Front Slides	S - 21
- Bearing Sleeve	S - 24
- Drum Removal	S - 22
Exhausting	S - 7
Motor	S - 2
Test Harness	S - 3

# DRIVE DRUM & AIR FLOW

## MOTORS

Two types of drive motors are currently in use — a FORM T and a FORM V. They are interchangeable and have the same ratings and connections. The number 3 terminal on the external centrifugal switch (FORM T) is connected internally and has no external wiring harness connection.

### Motor Rating

1/4 HP, 120V, 60 Hertz, 1725 RPM, 5.4 Amps @ full load. Rotation is clockwise as viewed from the terminal end. Permanently lubricated bearings and has an automatic reset overload protector.

### Form T Type

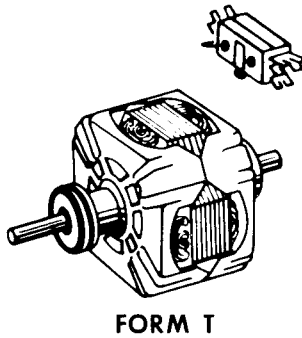


Figure 1

External Centrifugal Switch: Form "T" Motor

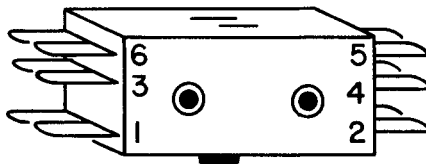


Figure 2

Form V Type

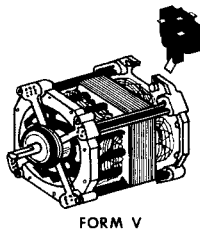


Figure 3 External Centrifugal Switch: Form "V" Motor

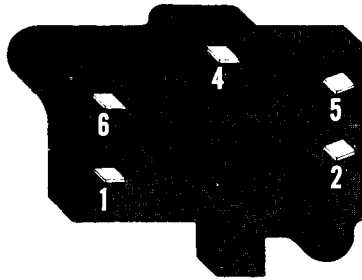


Figure 4

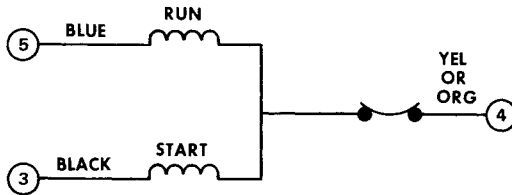
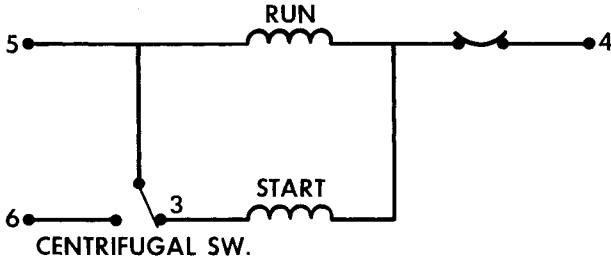


Figure 5.1 — Colors Designate wires between Motor & Centrifugal Switch - Not Harness Wires.

**Test Harness**

To check the motor use Test Harness WX5X184.

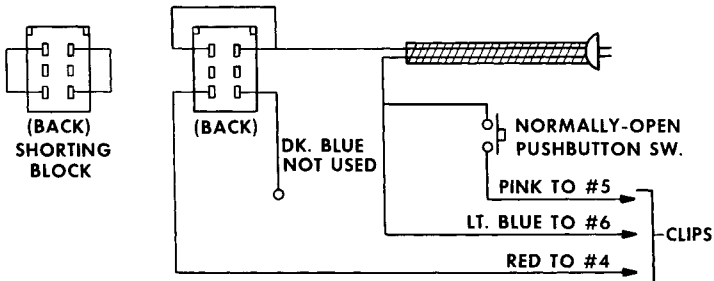


Figure 6 — Test Harness WX5X184 Schematic

## **DRUM DRIVE & AIR FLOW**

1. Attach shorting block to test harness block.
2. Remove all 5 wires from motor terminals.
3. Attach test harness clips to motor terminals

Pink to #5

Lt. Blue to #6

Red to #4

The dark blue is not used and must be insulated.

4. Plug test harness into a 120 VAC wall receptacle and momentarily depress test harness push button.
5. If motor runs it is okay. If not, replace motor. (NOTE: Centrifugal switch is bad if motor runs only when pushbutton is depressed).
6. Disconnect and insulate wires from terminals 1 and 2. Check for continuity between terminals No. 1 and No. 2 with ohmmeter while motor is running. Terminals 1 - 2 should be closed when motor is running but open when motor stops.

## **AIR FLOW AND SEALS**

There are three air flow systems in use — Gas, Electric and Electric-High Air Flow. The two electrics are the same except for the blower wheel diameter and the exhausting specifications.

### **Air Flow & Seals - Gas (Figure 7) SCD, LCD, LLCD**

Proper air flow through the dryer is essential for normal operation of the temperature control and safety systems. Air is PULLED into the cabinet lower front. A portion of this air is heated by the gas burner in the combustion chamber and is pulled up the rear duct into the diffuser. The remainder of this air enters the diffuser directly through vents and is mixed with the heated air. This hot mixed air is PULLED into the drum rear, across the clothes load, through the lint trap and down the trap duct into the blower. From the blower, the air is PUSHED out the exhaust system.

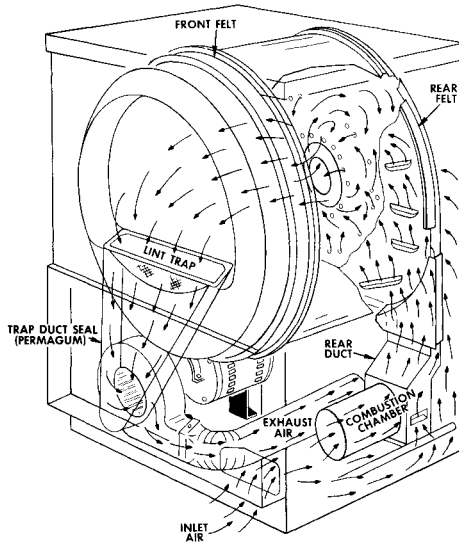


Figure 7

**Air Flow & Seals - Electric (Figure 8) SCD, LCD**

Proper air flow through the dryer is essential for normal operation of the temperature control and safety systems. Air is PULLED into the cabinet lower front, and drawn up across the heaters located behind the drum in the heater housing. This hot air is PULLED into the drum rear, across the clothes load, through the lint trap and down the trap duct into the blower. From the blower the air is PUSHED out the exhaust system.

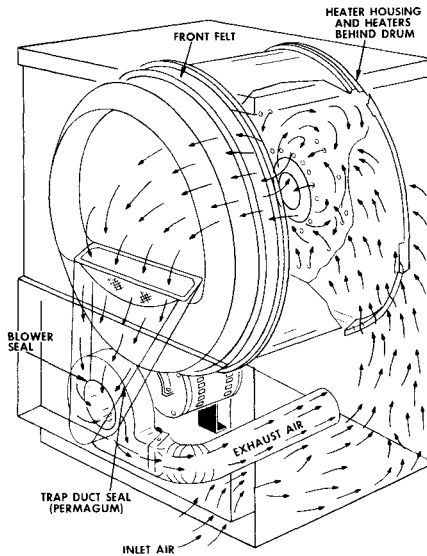
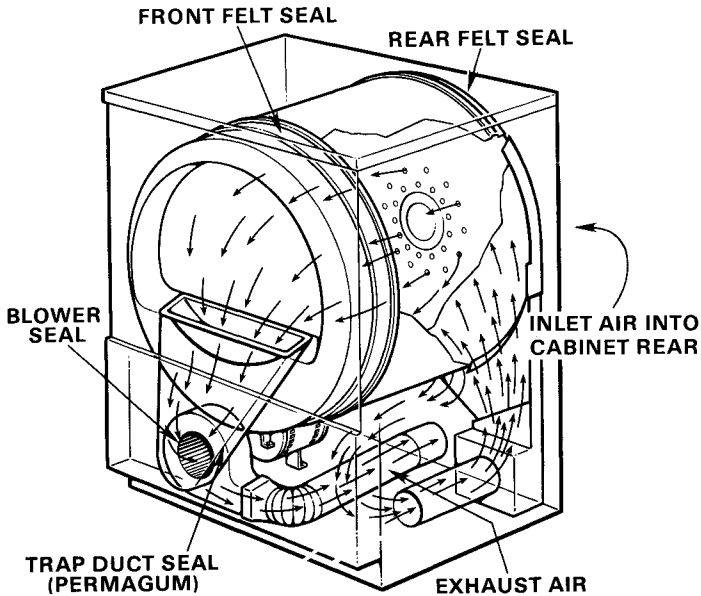


Figure 8

# DRIVE DRUM & AIR FLOW

## Air Flow & Seals - Electric (Figure 8A) LLCD



**Figure 8A**

Proper air flow thru the dryer is essential for normal operation of temperature control and safety systems. Most of the air is **PULLED** into the cabinet rear, towards the lower front of the cabinet, and thru the heater housing located at the bottom right. This hot air is **PULLED** into the drum rear, across the clothes load, thru the lint trap and down the trap duct into the blower. From the blower air is **PUSHED** out of the exhaust system.

## Leaks

Any air leaks between the air inlet and the blower such as rear duct, diffuser, rear or front drum felt, trap duct to cabinet front sealing or around door gasket will result in improper temperatures. The air being pulled down the trap duct across the drum outlet thermostat will be cooler than normal, giving this thermostat a false indication (delayed or no-trip). Leaks before the blower on electric dryers will also reduce the volume of air across the heaters causing hot spots and possible premature failure. Leaks before the blower on gas dryers will reduce the volume of air through the combustion chamber causing cycling of the inlet hi-limit thermostat.

## Trap Duct Sealing

To inspect the trap duct for proper sealing, it will be necessary to remove the dryer front. While viewing the front assembly from the drum side, shine a light down the lint trap and examine the trap duct on all sides where it meets the dryer front for voids in sealing. A strong light is a must for detection of leaks in this area. Leaks may be sealed with permagum.

## EXHAUSTING — GAS & ELECTRIC

### Caution: For Personal Safety

Do not terminate exhaust in a chimney, under an enclosed house floor (crawl space) or into an attic, since the accumulated lint could create a fire hazard or moisture could cause damage. Never terminate the exhaust into a common duct or plenum with a kitchen exhaust since the combination of lint and grease could create a fire hazard.

### Exhaust To Outside

The total length of exhaust ducting and number of turns must be kept to an absolute minimum in order to reduce the potential for lint accumulation and to minimize the resistance to air flow.

An improperly installed exhaust system may cause complaints ranging from "long drying time" to "never stops". On gas dryers it may cause rapid burner cycling and improper drying results. On electric dryers it may cause heater failures.

### Sealing of Joints

All joints should be tight to avoid leaks. The male end of each section of duct must point away from the dryer. Do not assemble the ductwork with screws or other fasteners that extend into the duct, as they will serve as a collection point for lint. Duct joints can be made air and moisture tight by wrapping the overlapped joints with duct tape.



# DRIVE DRUM & AIR FLOW

## Insulation

Ductwork which runs through an unheated area or which is situated adjacent to an air conditioning duct should be insulated to reduce condensation and lint accumulation.

- All exhaust systems must be terminated in such a manner as to prevent back drafts from the outside as well as to prevent the entry of birds or other wildlife.
- The termination should present minimal resistance to the exhaust flow and should require little or no maintenance to prevent clogging. Never install screen over exhaust duct.
- The preferred termination is a dampered wall cap having a 4" wide opening, (see table below). It must be installed with the opening pointed down, and must be spaced a minimum of 12" above ground level or any other obstruction.
- If other terminations are used, such as roof vents or louvered plenums, they must be equivalent to a 4" dampered wall cap with regard to resistance to air flow, prevention of back drafts and maintenance required to prevent clogging.

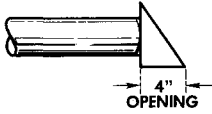
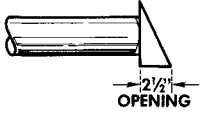
## EXHAUST DUCT LENGTH CALCULATIONS ELECTRIC MODELS (EXCEPT 5300, 1550)

### RIGID

Parts are available from your local service organization:

WX8X63	4" X 1' Duct
WX8X64	4" X 2' Duct
WX8X51	4" Elbow
WX8X59	4" Aluminum hood, Long Tail

## DRUM DRIVE & AIR FLOW

Number of 90° Turns Separated by at least 4 Ft. of Straight Run	Cat. No. WX8X59 (Preferred)	
		
0	45 feet	30 feet
1	35 feet	20 feet
2	25 feet	10 feet

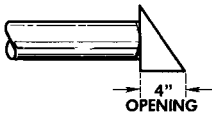
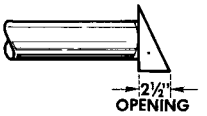
Maximum allowable length of 4" diameter rigid duct, providing the exhaust system meets the conditions stated in the following text.

**MORE THAN TWO 90° TURNS IS NOT RECOMMENDED.**

### FLEXIBLE

USE METALLIC FLEXIBLE DUCT ONLY. The following kit or parts are available from your local service organization. Duct need not be cut. Kit WX8X66 - 7' aluminum duct and 4" hood, short tail OR Individual Parts

	WX8X65	7' aluminum duct
and	WX8X58	4" clamps (2)
	WX8X59	4" aluminum hood, long tail

Number of 90° Turns Separated by at least 4 Ft. of Straight Run	Cat. No. WX8X59 (Preferred)	
		
0	30 feet	15 feet
1	25 feet	10 feet
2	10 feet	—

Maximum allowable length of 4" diameter metallic flexible duct, providing the exhaust system meets the conditions stated in the following text.

# DRIVE DRUM & AIR FLOW

## SEPARATION OF TURNS

- All turns in the exhaust system should be separated by at least 4 ft. of straight duct, including the distance between the last turn and the dampered wall cap. In the event two turns must be closer than 4 ft., deduct 10 ft. from the maximum lengths shown in the tables for each such occurrence.

## URNS OTHER THAN 90°

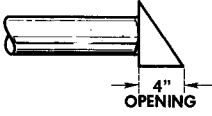
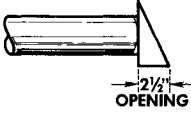
- One turn of 45° or less may be ignored.
- Two such turns should be treated as one 90°.
- Each turn over 45° should be treated as one 90°.

## GAS MODELS

### RIGID

Parts are available from your local service organization:

WX8X63	4" X 1' Duct
WX8X64	4" X 2' Duct
WX8X51	4" Elbow
WX8X59	4" Aluminum Hood, Long Tail

Number of 90° Turns Separated by at least 4 Ft. of Straight Run	Cat. No. WX8X59 (Preferred)	
		
0	35 feet	30 feet
1	25 feet	20 feet
2	15 feet	10 feet

Maximum allowable length of 4" diameter rigid duct, providing the exhaust system meets the conditions stated in the following text.

**MORE THAN TWO 90° TURNS IS NOT RECOMMENDED.**

# DRIVE DRUM & AIR FLOW

## FLEXIBLE

USE METALLIC FLEXIBLE DUCT ONLY. The following kit or parts are available from your local service organization. Duct need not be cut. Kit WX8X66 - 7' aluminum duct and 4" hood, short tail OR Individual Parts

and            WX8X65      7' Aluminum duct  
                   WX8X58      4" clamps (2)  
                   WX8X59      4" aluminum hood, long tail

Number of 90° Turns Separated by at least 4 Ft. of Straight Run	Cat. No. WX8X59 (Preferred)	
0	30 feet	15 feet
1	20 feet	10 feet
2	10 feet	—

Maximum allowable length of 4" diameter metallic flexible duct, providing the exhaust system meets the conditions stated in the following text.

### SEPARATION OF TURNS

- All turns in the exhaust system should be separated by at least 4 ft. of straight duct, including the distance between the last turn and the dampened wall cap. In the event two turns must be closer than 4 ft., deduct 10 ft. from the maximum lengths shown in the tables for each such occurrence.

### TURNS OTHER THAN 90°

- One turn of 45° or less may be ignored.
- Two such turns should be treated as one 90°.
- Each turn over 45° should be treated as one 90°.

If other terminations are used, such as roof vents or louvered plenums, they must be equivalent to a 4" dampened wall cap with regard to resistance to air flow, prevention of back drafts and maintenance required to prevent clogging.


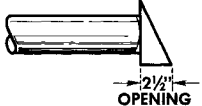
# DRIVE DRUM & AIR FLOW

## ELECTRIC-HIGH AIR FLOW ONLY (DDE5300, DLB1550)

### RIGID

Parts are available from your local service organization:

- WX8X63      4" X 1' Duct
- WX8X64      4" X 2' Duct
- WX8X51      4" Elbow
- WX8X59      4" Aluminum hood, Long Tail

Number of 90° Turns Separated by at least 4 Ft. of Straight Run	Cat. No. WX8X59 (Preferred)	
		
0	90 feet	65 feet
1	70 feet	45 feet
2	60 feet	35 feet
3	50 feet	25 feet
4	40 feet	—

Maximum allowable length of 4" diameter rigid duct, providing the exhaust system meets the conditions stated in the following text.

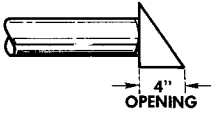
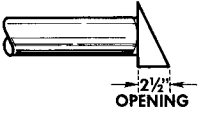
**MORE THAN FOUR 90° TURNS IS NOT RECOMMENDED**

### FLEXIBLE

USE METALLIC FLEXIBLE DUCT ONLY. The following kit or parts are available from your local service organization. Duct need not be cut. Kit WX8X66 - 7' aluminum duct and 4" hood, short tail OR Individual Parts

- WX8X65      7' aluminum duct
- and          WX8X58      4" clamps (2)
- WX8X59      4" aluminum hood, long tail

## DRIVE DRUM & AIR FLOW

Number of 90° Turns Separated by at least 4 Ft. of Straight Run	Cat. No. WX8X59 (Preferred)	
		
0	60 feet	40 feet
1	45 feet	25 feet
2	40 feet	20 feet
3	30 feet	—
4	20 feet	—

Maximum allowable length of 4" diameter metallic flexible duct, providing the exhaust system meets the conditions stated in the following text.

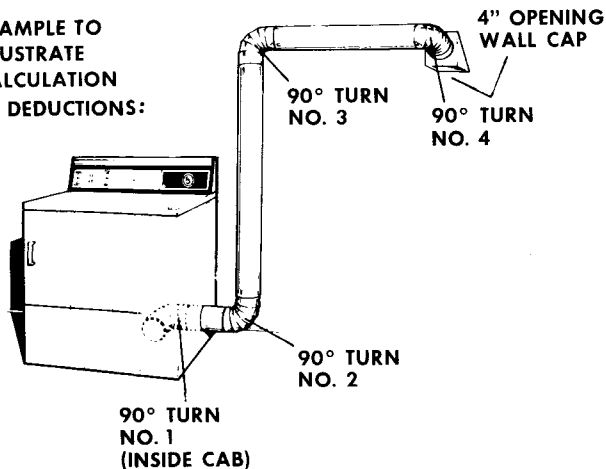
### SEPARATION OF TURNS

- All turns in the exhaust system should be separated by at least 4 ft. of straight duct, including the distance between the last turn and the dampered wall cap. In the event two turns must be closer than 4 ft., deduct 10 ft. from the maximum lengths shown in the tables for each such occurrence.

### TURNS OTHER THAN 90°

- One turn of 45° or less may be ignored.
- Two such turns should be treated as one 90°.
- Each turn over 45° should be treated as one 90°.

**EXAMPLE TO ILLUSTRATE CALCULATION OF DEDUCTIONS:**



# DRIVE DRUM & AIR FLOW

## Maximum Length Calculation

Max. Length of rigid duct for installation with 4 turns from table.

Deduction for turns No. 1 and No. 2 than 4 ft.

Deduction for turn No. 3

Deduction for turn No. 4 and wall cap closer than 4 ft.

Maximum length of rigid duct for this installation

## Exhaust to Inside

### SCD, - ELECTRIC

Fasten deflector, WE14X56, over exhaust port as shown in Figure 10.

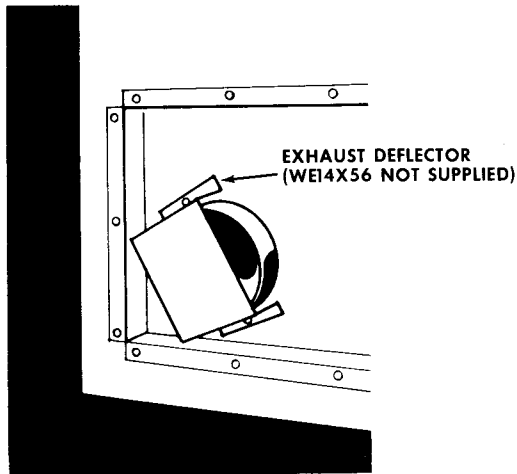


Figure 10

### LLCD - ELECTRIC & GAS

Attach 90° Elbow, WE25X28, to exhaust port - open end pointed 45° to left (viewed from rear) as shown in Figure (10A).

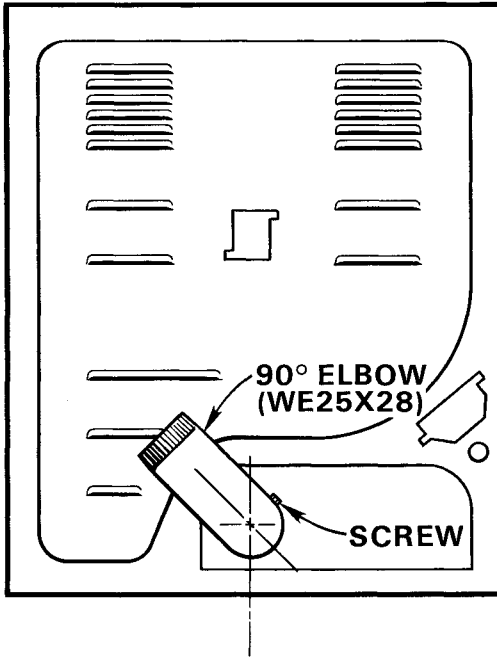


Figure 10A

**SCD - GAS, LCD - ELECTRIC & GAS**

Attach 90° Elbow, WE25X28, to exhaust port - open end pointed straight up.

Listed below are a number of important points to consider when installing a dryer exhaust system:

**DO**

DO exhaust to the outside whenever possible.

DO use short runs and as few turns as possible.

DO use 4" diameter rigid (aluminum or galvanized) ductwork whenever possible.



## DRUM DRIVE & AIR FLOW

DO use a 4" dampered wall cap whenever possible.

DO provide access for periodic inspection and cleaning of the duct system, especially at the turns.

DO use duct tape to seal all joints.

DO insulate the ductwork when passing through cold areas or contacting cold surfaces.

Do use rigid elbows for turns.

### DO NOT

DO NOT exceed the maximum allowable duct length.

DO NOT use screws to assemble the ductwork.

DO NOT terminate the exhaust in a chimney, attic or under an enclosed floor.

DO NOT connect the dryer exhaust to a common duct or plenum with kitchen or bathroom exhausts.

DO NOT use non-metallic flexible duct.

### DRIVE SYSTEM — SCD, LLCD

These models use 2 different belt tension systems. The earlier system uses a shackle and a spring loaded idler arm (Figs. 11 & 12).

Models with the suffix letters shown in the chart below began using the later system which uses a torsion bar idler spring (Fig. 12A).

DRYER MODEL SUFFIXES			
ELECTRIC		GAS	
DDC	BB	DDC	BC
	AE		AE
	VE		VE
DDE	BB	DDG	BC
	VJ		VK
	DB		DB
DLB	BB	DLL	BC
	DB		DB

## EARLY SYSTEM

The drum is rotated counterclockwise, as viewed from the front, at a speed of 47 - 50 RPM. Belt tension is maintained by a spring loaded idler pulley and driven by a pulley attached to the rear motor shaft, Figure 11.

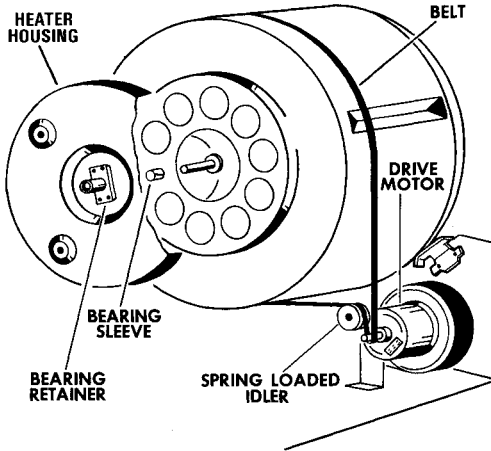


Figure 11

### Belt Alignment

Proper alignment of the drive belt must be maintained to eliminate:

1. "Belt Off" - Riding off the rear of the motor pulley.
2. "Broken Belt" or "Fast Tumble Speed" resulting from the belt riding forward on the motor pulley, turning the drum faster, and ultimately being damaged by the motor pulley set screw.

If a damaged belt is found, inspect the motor pulley grooves for smoothness and remove any belt threads that may have been wound around the pulley. After the new belt is installed, check the belt alignment as follows:

### Belt Alignment Check

Remove the rear cabinet access panel. Rotate the drum by hand clockwise and then counterclockwise several revolutions. Observe the tracking or position of the belt on the idler pulley. If the belt tracks near either the front or rear edge of the idler pulley, bend the idler arm as shown to center the belt on the idler pulley, Figure 12.

# DRIVE DRUM & AIR FLOW

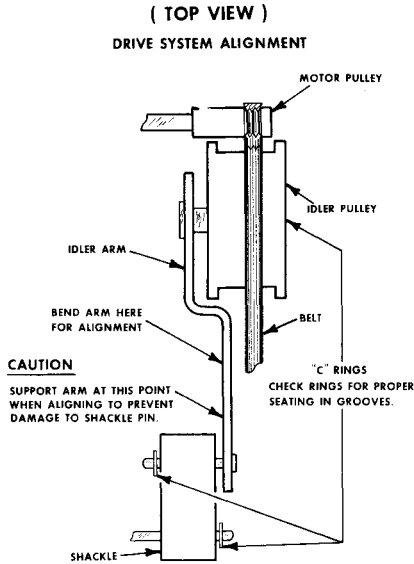
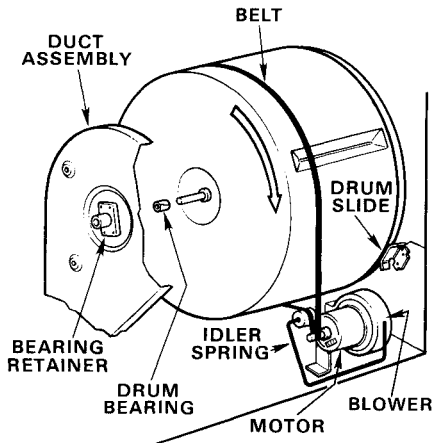


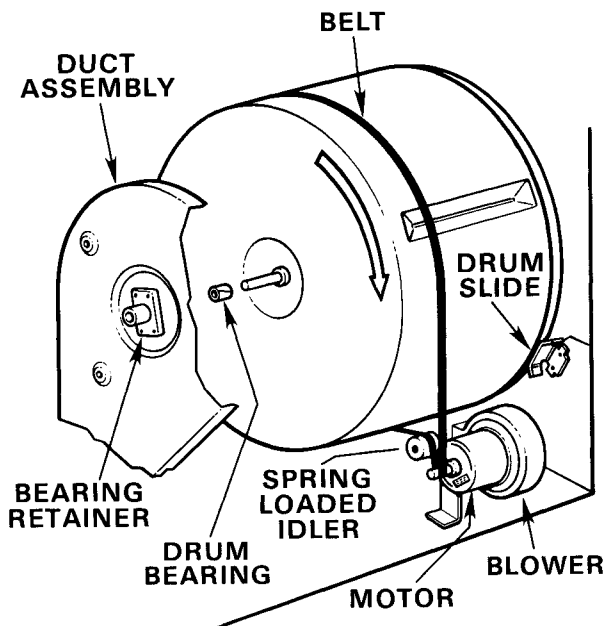
Figure 12

NOTE: The belt ridges and motor pulley grooves must match.

## LATER SYSTEM-TORSION BAR

The drum is rotated counterclockwise, as viewed from the front, at a speed of 47-50 RPM. Belt tension is maintained by a torsion bar which is fastened to the dryer base by an idler spring bracket and screws. One end of the bar holds the pulley and the other end rests against the blower housing. Looking from the rear of the dryer the drum belt is twisting the idler spring in a counterclockwise direction.





**FIGURE 12A**

There is no adjustment for belt misalignment. If the belt does not track properly on the idler pulley replace both the idler spring (torsion bar) and the bracket which holds it to the dryer base.

### **Motor/Blower Removal — All Models**

Remove drum, remove blower housing screws on cabinet front. Release rear motor mounting clip and remove motor/blower assembly for service.

### **Lubrication**

Should it become necessary to lubricate drum or drum slides use WE25X94 oil. DO NOT SUBSTITUTE.

To lubricate idler pulley bearings use WE25X46 grease only.

### **DRIVE SYSTEM — LCD**

The drum is rotated counterclockwise at 44 - 46 R.P.M. Belt tension is maintained by a spring loaded idler pulley and driven by a pulley attached to the rear motor shaft.

## DRIVE DRUM & AIR FLOW

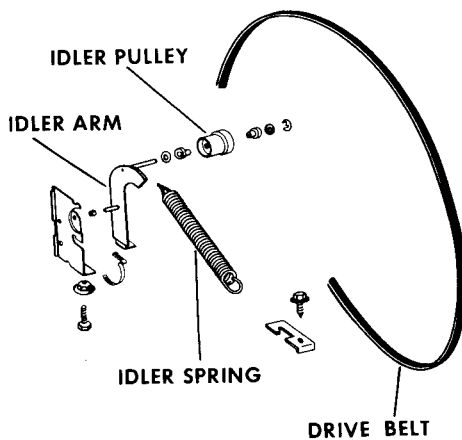


Figure 13

### BELT REPLACEMENT — REMOVE POWER

From the front - remove the cabinet front and rotate to the side. Do not disconnect harness. Tilt front of drum up just enough to slip the new belt between the drum and the two slides. Locate the belt about the center of the drum. Then, either -

From the rear - remove the rear panel. Reach in with the left hand and pull the idler pulley arm to the left. With the right hand fit the belt over the motor pulley and idler. Release the idler arm slowly to take up the slack in the belt - see Figure 14.

or

From the front - raise the drum up and to the right with the right hand. Reach in between the drum and cabinet with the left hand, and, with a little practice, you can -

1. Push the idler arm over to the right.
2. Fix the belt over the idler pulley and under motor pulley.
3. Slowly release the tension on the idler arm.

Make sure that belt is properly seated in the motor pulley grooves and that it is riding on the smaller diameter of the idler pulley. As a final check rotate drum 1 full turn counterclockwise and then 1 full turn clockwise.

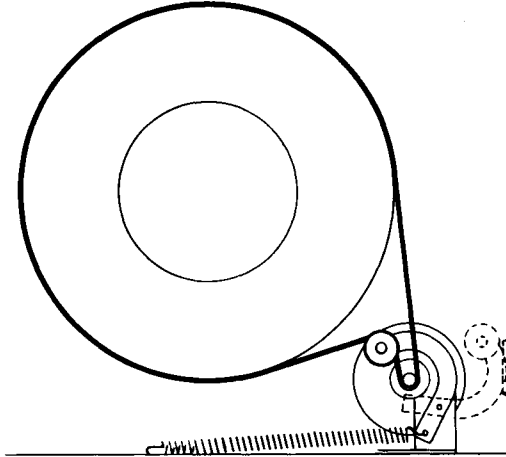


Figure 14

**CAUTION:** Idler arm is under tension. When released, it will move to position indicated by the broken lines in Figure 14.

### Motor/Blower Removal — All Models

Remove drum. Remove blower housing screws on cabinet front. Release rear motor mounting clip and remove motor/blower assembly for service.

### Lubrication

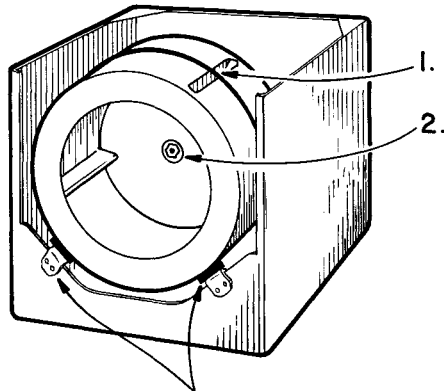
Should it become necessary to lubricate drum or drum slides use WE25X94 oil. DO NOT SUBSTITUTE.

To Lubricate idler pulley bearings use WE25X46 grease only.

### DRUM SUPPORT — FRONT SLIDES — ALL

The drum is supported at the front by two Teflon slides. They may be replaced by removing the dryer front. Do not remove the drum. Lubricate slides with WE25X94 oil only. Do not apply oil to belt area or inside drum. For Cabinet Cover and Front disassembly instructions - see CABINET CONSTRUCTION, SECTION T.

# DRUM DRIVE & AIR FLOW



**NEW SLIDES MUST BE  
LUBRICATED - USE  
WE25X94 OIL ONLY.**

**Figure 15**

## **Drum Removal**

Drums without a plug button.

### **METHOD #1**

1. Carefully remove "E" ring and washers from rear of drum shaft which is located under the small cover plate at the rear center of the cabinet.
2. Remove drum and deflector assembly. The shaft will be removed with the drum.

## **Drum Replacement**

1. With Teflon washer, steel washer, and bearing sleeve on drum shaft, slide shaft and bearing carefully into bearing retainer on heater housing.
2. Replace spacer washers and "E" ring.
3. Reposition belt around drum and onto motor and idler pulleys.

### **METHOD #2 (GE V Models & Earlier, HPT A Models & Earlier)**

Raise cover and remove cabinet front. Release belt from idler pulley.

1. Remove one drum mounting screw and drive it into the small tooling hole (Figure 16.) This secures the heat deflector to the drum and acts as a parts holding screw.
2. Remove the two remaining drum mounting screws. Remove the drum.

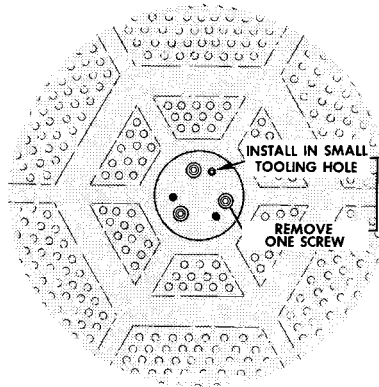


Figure 16

**Drum Replacement**

1. Rotate drum support bracket with one notch at the 12 o'clock position Figure 17.

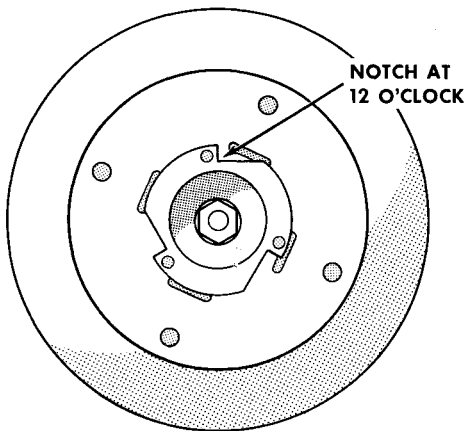


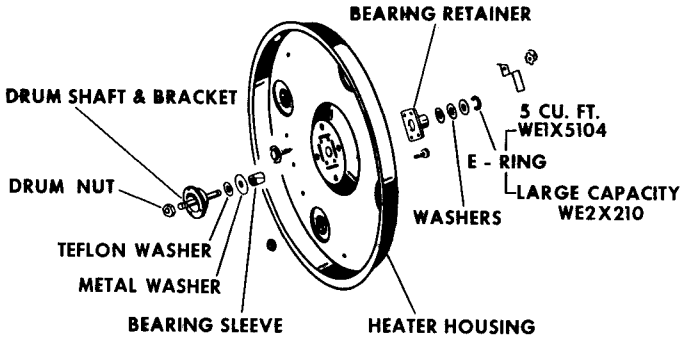
Figure 17

2. Position the drum in the dryer with the parts holding screw resting in the top notch. This supports the weight of the drum allowing you to align the two bottom holes and install the other two drum mounting screw.
3. Remove the parts holding screw and install in the remaining mounting hole.



# DRUM DRIVE & AIR FLOW

## Bearing Sleeve - Replacement



**Figure 18**

Remove drum from cabinet by METHOD #1.

It is highly recommended that a new drum shaft and a new bearing retainer be used with a new bearing.

However, if only the bearing is to be replaced remove old bearing from the shaft or from inside the bearing retainer. Slip new bearing onto shaft and reassemble drum into cabinet.

If a Drum Bearing and Shaft Kit is being used:

1. Remove old drum shaft, bearing retainer, bearing ground strap, and washers.
2. Fasten new bearing retainer to heater housing with 4 screws provided.
3. Fasten new drum shaft and deflector to drum with 3 screws provided.
4. Put Teflon washer and then large metal washer on drum shaft. Put bearing sleeve on the drum shaft.
5. Install drum. Make sure bearing sleeve is not pushed out back end of bearing retainer.
6. Put 2 to 4 small metal washers (depending on space to E-ring groove) on drum shaft. Then install E-ring.
7. Install ground strap over end of screw so that metal clip on ground strap touches end of drum shaft. Secure ground strap with special fastener provided.

# CABINET CONSTRUCTION

## CABINET CONSTRUCTION INDEX

	<b>PAGE</b>
Backsplash	T - 2
Cabinet Disassembly - SCD, LLCD	T - 3
- LCD	T - 4
Door Adjustment - SCD, LLCD	T - 5
- LCD	T - 6
Drum Gap Adjustment	T - 6

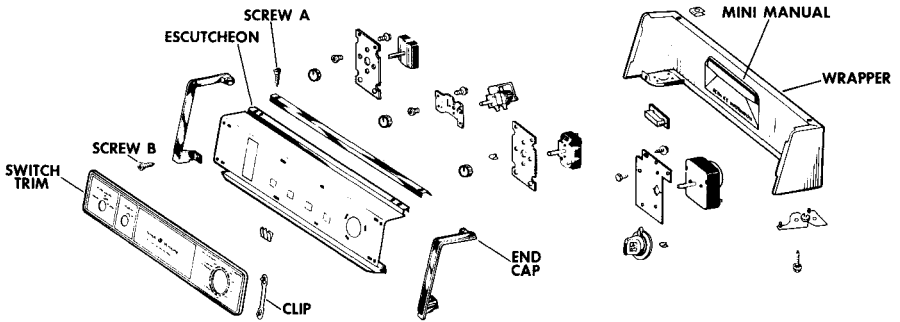
# CABINET CONSTRUCTION

## BACKSPLASH DISASSEMBLY

Low Style (6 inch) Ref Fig. 1

1. Remove 2 screws "A"
2. Remove 2 screws "B"
3. Roll top of escutcheon towards front of dryer.

Timer and Switches are now accessible.

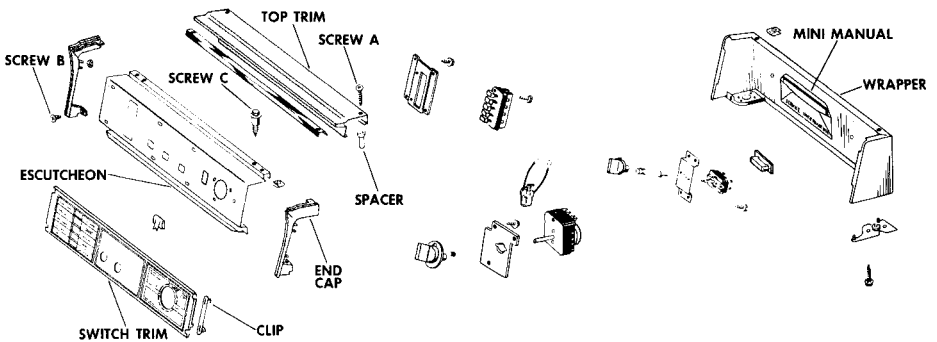


**Figure 1 6 inch Backsplash - Exploded View**

High Style (7 inch) Ref. Fig. 2

1. Remove 2 screws "A"
2. Lift rear of top trim and roll towards front of dryer.
3. Remove 2 screws "B".
4. Remove 2 screws "C".
5. Roll top of escutcheon towards front of dryer.

Timer and Switches are now accessible.



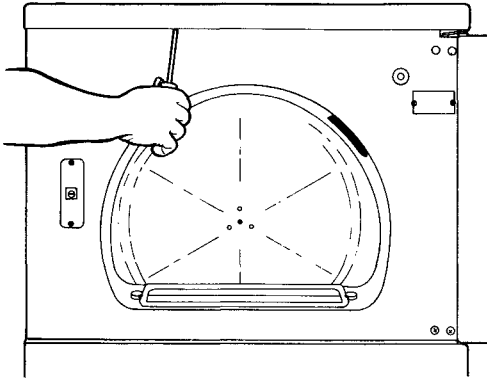
**Figure 2 7 inch Backsplash - Exploded View**

## CABINET DISASSEMBLY — SCD, LLCD

---

### Cover Removal

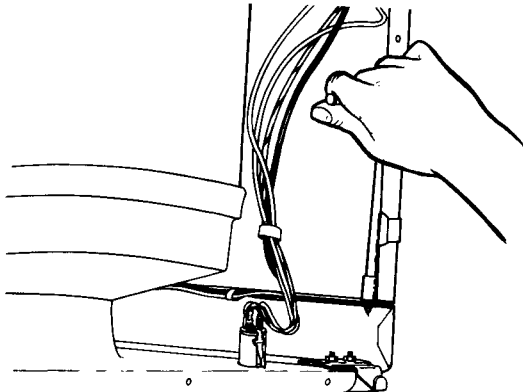
1. Remove the screws securing the front to the underside of the cover, Figure 3.



**Figure 3 — Raise Cover**

### Front Removal

1. Raise cover.
2. Loosen the two screws located in the tabs of the cabinet front at each side in the kickplate area.
3. Then remove the screws holding the front to the cabinet, Figure 4.
4. Release wire harness clip at right front corner.
5. Lift up front assembly and set to one side.



**Figure 4 — Front Removal**

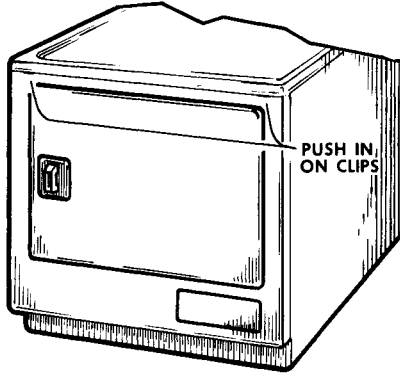
# CABINET CONSTRUCTION

## DOOR ADJUSTMENT — LCD

---

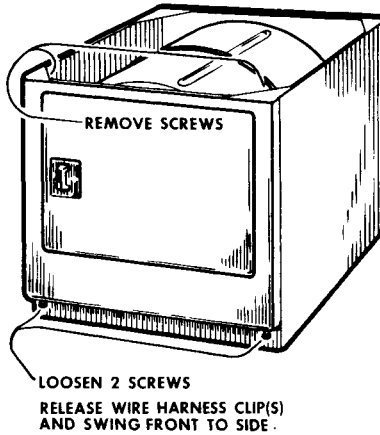
### To Remove Cover

With putty knife or similar thin tool, push in on spring clips and lift 2". Slide cover to rear to release rear of cover.

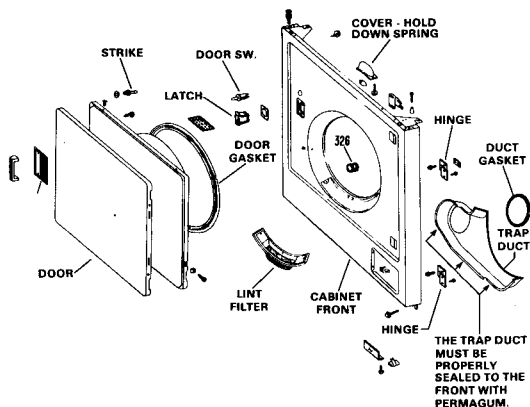


**Figure 5**

### To Remove Front



**Figure 6**

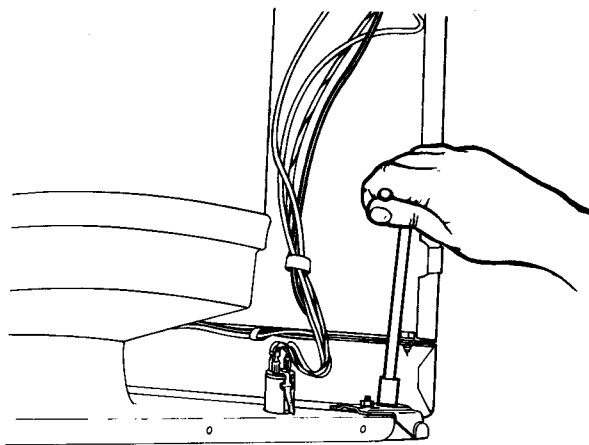


**Figure 7**

**NOTE:** Before reassembling front to cabinet, check condition and positioning of drum felt, duct gasket, and wire harness to drum clearance.

## DOOR ADJUSTMENT — SCD, LLCD

The cabinet door is adjustable at the upper hinge only. To adjust door, remove dryer top. Loosen two hex nuts, Figure 8. Align the door with the cabinet front and retighten the nuts.



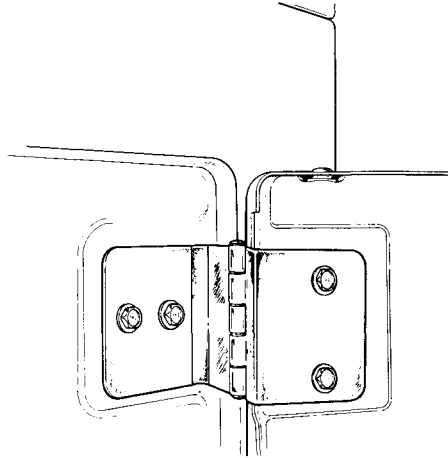
**Figure 8 — Door Hinge Adjustment**

# CABINET CONSTRUCTION

## DOOR ADJUSTMENT — LCD

The screw holes in the door side of the hinges are slotted horizontally. The screw holes in the cabinet side of the hinges are round.

To center the door loosen the two screws in the door side of the top hinge. Adjust the door and retighten the screws. It may be necessary to also loosen and retighten the two screws in the bottom hinge.



**Figure 9**

## DRUM GAP ADJUST

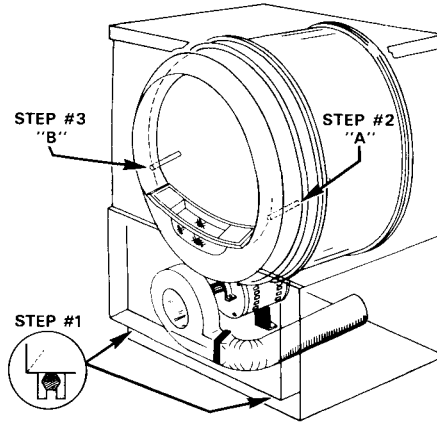
All Dryers — Clothes may be damaged due to improper drum gap.

Damage caused by improper drum gap usually appears as cuts on collar corners, cuffs or garment edges. The damage usually occurs at the 3 o'clock position on the drum, between the drum front and cabinet front loading ring when the gap is too small. To check for correct drum gap, (See Figure 10).

1. Be sure dryer front panel is seated down and secure on lower mounting screws and side panel index tabs are positioned in front panel slots.
2. Insert a spacer at Point "A". 1/10 inch diameter dowel rod or similar gauge between drum and front loading ring lip. Rotate drum one complete turn. If the drum rubs the spacer, remove the front panel and adjust the right drum slide down by bending. Reinstall front and check for proper clearance.
3. As in step 2 check for clearance at point "B" by rotating drum one complete turn.

If additional adjustment is necessary be sure to re-check point "A" for the desired clearance as adjustments will interact.

4. If the proper clearance cannot be obtained on each side determine if the difficulty is being caused by —
- Drum out of round.
  - Front panel loading ring mis-formed.



**Figure 10**





**DRYER DIAGNOSIS****CHECK**

Dryer will not start	Electric - Both fuses or circuit breakers. Gas - Fuse or circuit breaker. Wall Receptacle Voltage Cordset Terminal Block Door Switch Start Switch Motor Centrifugal Switch Timer Contacts TB - TC Motor Winding M3 - M4 Wiring
Motor Starts But Will Not Keep Running When Start Switch Is Released.	Motor Centrifugal Switch, M3-M6 Run Winding for Continuity, M4-M5 Wiring
Motor Runs But No Heat	Motor Centrifugal Switch, M1 - M2 Timer Contacts TB - TA Thermostats Selector Switch Contacts Wiring <u>ELECTRIC Only -</u> Heater Coils Fuses or Circuit Breakers Wall Receptacle Cordset Terminal Block  <u>GAS Only -</u> Gas Supply GloBar Ignitor Detector Gas Valve Coils
Dryer will not turn off - with or without heat.	Auto Cycle Air Leaks Timer Motor Timer Contacts TB - TC Thermostats Ambient Temperature too low Resistor

# DIAGNOSIS

Timed Cycle  
Timer Motor  
Timer Contacts TB - TC

Dryer Stops During Cycle

Drum Drive Belt  
Lint in Motor  
Door Switch  
Timer Contacts TB - TC  
Fuses or Circuit Breakers  
Motor Run Winding

Clothes Too Hot-Fabric Damage

Exhaust System for Restrictions  
Air Leaks Around Rear Duct,  
Diffuser, Drum Felts, Trap  
Duct to Cabinet Front.  
Thermostats  
Temperature Setting by Customer.  
Door Latch & Strike.

## SAFETY

SAFETY is of no less importance than performance, in the design and manufacture of Dryers.

Therefore, SAFETY, at such time as service is required, should also be a prime consideration of the service technician.

The following information is grouped as INSTALLATION, SERVICE, USE. It should serve as a guideline to insure that the SAFETY features designed into the product at the time of manufacture are maintained throughout the life of the appliance.

This information is not all inclusive; however, it is intended to serve as a general guideline by which we may remain alert to areas influencing the continued SAFE operation of Dryers.

## INSTALLATION

### **Power Supply:**

- Correct Wire Size
- Correct Fuse or Circuit Breaker Rating
- Correct Supply Voltage
- Proper Grounding — To METAL Cold Water Pipe or other established ground
- 240V Models — Pigtail Connections Secure (was a strain relief used)
- 120V Models: NEVER Remove the Third (ground) Prong from the Power Cord.
- Replace All Access Plates

### **Electrical - Gas Dryer**

Each Gas Dryer is to be supplied by a separate circuit of proper voltage fused with a 15 or 20 Ampere time-delay fuse or circuit breaker, and terminated in a properly grounded three-prong wall receptacle (see Grounding). No other electrical device should be operated on the same circuit when the washer is operating.

## SAFE INSTALLATION & SERVICE

### EXTENSION CORD CAUTIONS

Because of potential safety hazards under certain conditions we strongly recommend against the use of an extension cord. However, if you still elect to use an extension cord, it is absolutely necessary that it be a UL listed 3-wire grounding type appliance extension cord and that the current carrying rating of the cord in amperes be equivalent to or greater than the branch circuit rating. Such extension cords are obtainable through your local service organization.

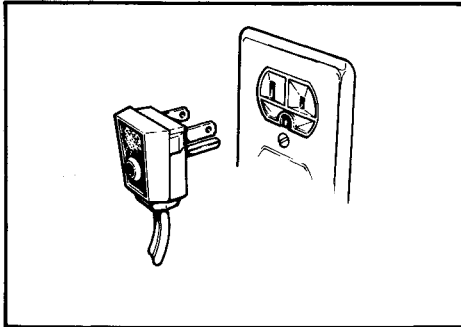
### Grounding

**IMPORTANT — PLEASE READ CAREFULLY!**

**FOR PERSONAL SAFETY, THIS APPLIANCE MUST BE PROPERLY GROUNDED**

The power cord on this appliance is equipped with a three-prong (grounding) plug which mates with a standard three-prong (grounding) wall receptacle.

Where a standard two-prong wall receptacle is encountered, it is the personal responsibility and obligation of the customer to have it replaced with a properly grounded three-prong wall receptacle.



**Figure 1**

**DO NOT, UNDER ANY CIRCUMSTANCES, CUT OR REMOVE THE THIRD (GROUND) PRONG FROM THE POWER CORD PLUG.**

## SAFE INSTALLATION & SERVICE

### Exhausting: (Refer Section S) Check:

- Exhaust duct size and length.
- Number of elbows and wall cap operation.
- For airleaks or fasteners protruding into air stream.

**NEVER** exhaust into a chimney or confined area, such as an attic or crawl space.

### Leveling

- The dryer should be leveled to prevent movement or vibration and legs securely locked in position.

# SAFE INSTALLATION & SERVICE

## Gas Connections:

- All connections secure and tested with soap solution — NO OPEN FLAME TESTING.
- Orifice sized for type gas being used — natural, L.P., etc.
- Supply line size and accessible shutoff valve.

**ALWAYS** consult the specific installation instruction for the model being installed.

## SERVICE

Some of the devices used on dryers to insure SAFE operation are:

- Start Switch
- Motor Heat Switch
- Gas valve Detector
- Door Switch
- Hi-Limit Thermostats
- Grounding Provisions

**NEVER** defeat or bypass these or any other component as a temporary repair

- Always disconnect power before servicing.

**TEST JUMPERS** — Should it be necessary to utilize jumpers for diagnosis, be certain these are removed upon completion of the repair.

**CONNECTIONS** — During diagnosis and service, all connections removed, such as spade connectors, should be checked upon reinstalling for a secure connection.

**WIRING** — Wiring harness should be dressed to original positions to eliminate contacting moving parts or areas of high temperature.

## After The Repair

- Electrical supply and ground wiring should be securely attached.
- **GAS DRYER**, gas supply line should be checked for leaks with soap solution.
- Dryer exhaust duct reconnected and checked for leaks. Relevel if necessary, replace all access plates and perform a final operational check.

## USE

The dryer should not be used with access panels removed.

Items which should not be put in the dryer are:

- Rubber backed rugs, foam rubber pillows or clothing containing rubber or plastic materials.

## SAFE INSTALLATION & SERVICE

- Items with plastic linings and any materials which contain chemicals such as wax, polish, or have been treated with flammable agents.

Gas dryers or 120V electric dryers should never have additional loads connected to their circuits while in operation, such as irons, television sets, etc.

The lint screen should be cleaned after each load and NEVER operate the dryer without the lint screen in place.

Exhaust duct system should be inspected and cleaned as needed.





**INDEX**

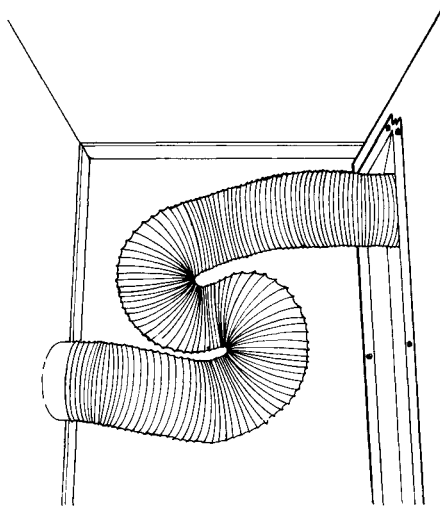
	<b>PAGE</b>
LLCD "D" Gas Model Performance	W - 5
No Ignition - Gas Models	W - 4
Overheating	W - 2
Dryer Rattling Complaints	W - 6
Chattering Gas Valve	W - 7

# FIELD CORRECTIONS

## DRYER OVERHEATING

Exhaust duct installations having either excessive total length or too many elbows or turns will reduce air flow and cause overheating. Consult the machine installation instructions for the recommended data for your particular model. Provide the customer with specific recommendations for correcting the installation and advise that if not corrected overheating can be expected to continue.

Reduced air flow in Electric & Gas dryers can cause higher than normal operating temperatures. This causes the hi-limit T'stats to trip and results in long drying time. The primary cause of reduced air flow is improperly installed exhaust ducting.



**Figure 1**

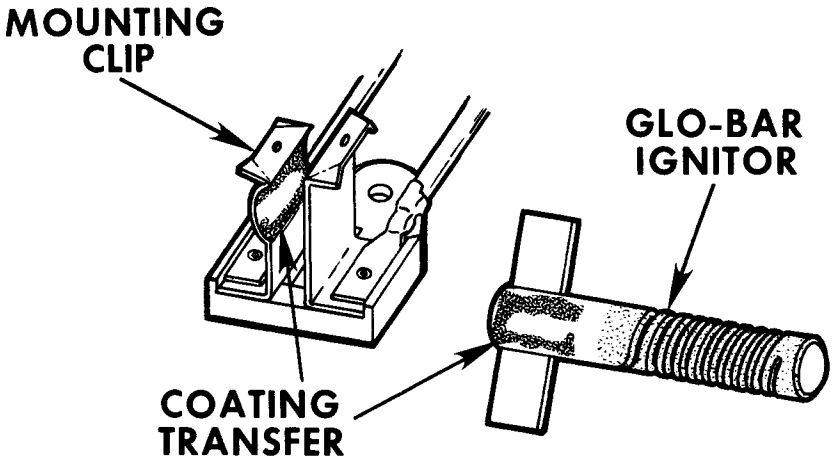
This installation is NOT acceptable. Excess turns and flex duct which is not stretched will reduce air flow causing excessive temperatures.

## No Ignition

The malfunction of a Glo-Bar ignitor, even though it is not broken, can be caused by a high resistance connection between the ignitor and its mounting clip. Some of the causes for this high resistance could be:

1. Transfer of the whitish, silver coating from one part to the other.
2. Foreign matter between the ignitor and clip.
3. A weak or loose clip.

If you find an ignitor or clip that displays coating transfer as shown below, change both parts.



Some of the following customer complaints may be received on gas dryers that have been converted from Natural Gas to LP Gas.

- Noise in the burner similar to a blow torch sputter or pop when the torch is turned off.
- Flame coming out of the rear of the burner.
- Flame goes out.
- No Dry

LP conversion kit, WE25X173, should resolve the problem. The gas port has been modified and an air shutter has been added. If the dryer already has an air shutter discard the extra one. WE25X173 is an automatic supersedure for the previous LP conversion kit.

## FIELD CORRECTIONS

### LARGE CAPACITY DRYER (LLCD) DRY PERFORMANCE COMPLAINTS

Only For Models Listed Below:

**DDG9280 DAL, DBL**  
**DDG8280 DAL, DBL**  
**DDG8188 VHL, VJL**  
**DDG8180 DAL, DBL**  
**DLL2880 DAL, DBL, DCL**

Under certain conditions of restricted air flow due to poor venting, load size, etc., the models listed above tend to cycle on the safety thermostat rather than the control thermostats. This condition results in long dry complaints and in general can not be repaired to the customer's satisfaction.

A LLCD Burner & Bracket Kit (WE25X187) is now available to make the above dryers **less** sensitive to restricted air flow and in most cases will prevent the dryer from "short cycling" on the safety thermostat. The kit includes a new burner assembly and thermostat bracket with several accessory parts. The safety thermostat (WE4X592) does **not** change and is **not** included with the kit. Also, the cover plate (WE20X655) attached to the front overhang is removed and discarded to allow greater air flow from the front of the dryer.

**THIS KIT HAS SPECIFICALLY BEEN DESIGNED  
FOR THE MODELS LISTED ABOVE AND MUST  
NOT BE USED ON ANY OTHER MODELS.**

## DRYER RATTLING NOISE COMPLAINTS (ALL LOUISVILLE PRODUCED DRYERS)

Investigations have determined that many of the rattling, thumping and bumping noise complaints were caused by the multiple piece idler pulley and bearing assembly used on all Louisville produced Gas and Electric Dryers. To reduce these complaints, a new one-piece idler pulley and bearing assembly was designed and is now in production.

To assist in resolving these complaints, the WE12X81 idler pulley replacement kit was established. The kit contains the required parts and an instruction sheet for converting to the one-piece design. The kit will adapt to either the torsion spring or the shackle and spring arm designs.

### KIT CONTENTS:

- 1 - Idler Pulley
- 1 - Spacer
- 1 - Instruction
- 1 - Push-On Nut

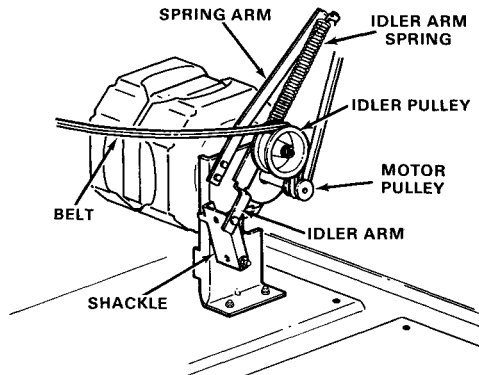
### INSTALLATION PROCEDURE:

#### Type "A" and "B" Idler Systems

- 1 - Disconnect electrical power to dryer.
- 2 - Disengage drive belt by pulling idler puller down and to the left.

#### Type "A" Idler System

- 1A - Remove "E" ring retaining clip; retain clip.
- 2A - Remove and discard washer, idler pulley and bearing assembly.
- 3A - Install kit spacer on idler arm shaft.
- 4A - Install kit idler pulley on idler arm shaft.
- 5A - Re-install "E" ring retaining clip.



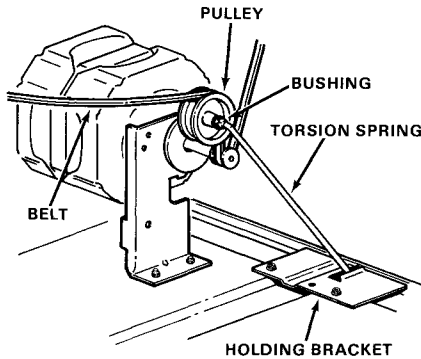
TYPE A IDLER SYSTEM

# FIELD CORRECTIONS

## INSTALLATION PROCEDURE:

### Type "B" Idler System

- 1B - Remove "Push-On" retaining nut.
- 2B - Remove and discard pulley, bearing assembly and bushing (if present).
- 3B - Install kit idler pulley on Torsion spring.
- 4B - Install "Push-On" nut: Nut should be positioned 1/4" from end of torsion spring.



**TYPE B IDLER SYSTEM**

**NOTE:** Kit spacer not required on Type "B" System.

### Type "A" and "B" Systems Cont'd.

- 3 - Re-install drive belt.
- 4 - Rotate dryer drum to check for proper belt alignment on idler and drive motor pulleys.
- 5 - Re-connect electrical power and check dryer operation.

## CHATTERING GAS VALVE (STANDARD AND LARGE CAPACITY GAS DRYERS)

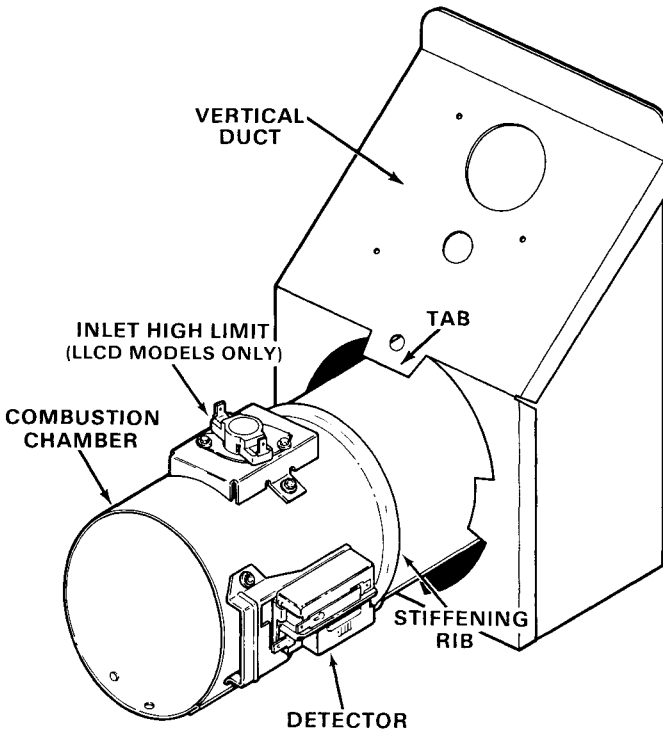
Long drying time complaints accompanied with rattling or abnormal noises may be due to vibrations of the combustion chamber causing the gas burner valve to chatter. The vibrations are induced by the motor and blower into the structural system including the combustion chamber and result in the flame detector contacts opening and closing rapidly. This in turn causes the main valve to chatter.

To correct this problem, replace the combustion chamber. Replacement parts have a stiffening rib formed into them to prevent this problem. The two part numbers involved are:

WE14X112 - (SCD) Standard Capacity Models

WE14X158 - (LLCD) Large Capacity Models

When replacing the combustion chamber, be sure the tab at the opening of the vertical transition duct is in firm contact with the combustion chamber. This tab positions and prevents vibration of the outlet end of the combustion chamber.







# PORTABLE AUTOMATIC DRYER

## PORTABLE AUTOMATIC DRYER

### INDEX

<b>CABINET DISASSEMBLY</b>	<b>PAGE</b>
Cabinet Interior	X - 6
Cabinet Top & Front Removal	X - 5
Cabinet Trim Removal	X - 3
Drum Bearing	X - 7
Drum Felt	X - 7
Drum Removal	X - 6
Drum Slides	X - 7
Heater Replacement	X - 8
High Limit Thermostat Replacement	X - 9
Lower Trim Panel Removal	X - 5
Switch Trim Panel	X - 3
<b>ELECTRICAL SYSEM</b>	
Drive Motor	X - 9
High Limit Thermostat Test	X - 9
<b>GENERAL INFORMATION</b>	
Electrical Requirements	X - 2
Installation	X - 2
Operating Specifications	X - 2
<b>SCHEMATIC</b>	
DDP1200PDC	X - 12
For 24" Dryer See Manual 31-2105	

# PORTABLE AUTOMATIC DRYER

## GENERAL INFORMATION

### Electrical Requirements

When the dryer is operating on 120V AC., 60 HZ. fuse with a 15 or 20 amp time delay fuse or circuit breaker, no other appliance should be in operation on the same circuit.

### Installation

- A. The dryer may be installed as unpacked on the four rubber feet already attached.
- B. The dryer may be installed with a caster kit. The caster kit and instructions are packed with each dryer.
- C. The dryer may be installed with a wall hang kit, (not supplied). The wall hang kit must be secured to walls utilizing 2 x 4 stud construction. Complete instructions are included in the kit. Order through sales department.

### Air Flow

Air flow is 45 C.F.M. The air intake is located on the rear of the dryer and exhaust is out the front. No provision for outside exhaust is provided. A lint screen is located on the dryer front, just below the door, and should be cleaned before each load.

### Heat

Heat is provided by a single heater coil, 1100 watts, 9.8 ohms cold.

### Motor

The drive motor is 1/12 H.P., 1725 R.P.M.'s. It has permanently lubricated bearings and an external centrifugal start switch. Motor rotation is clockwise, viewed from front.

### Drum

The drum speed is 56 R.P.M.'s and turns in a clockwise direction.

### Cycles

The dryer incorporates straight timed cycles. Three cycles are provided -Regular, Permanent Press, and Fluff. Approximately 12 minutes of cool down is provided at the end of each cycle.

## Performance

Typical drying times for standard cotton and permanent press fabrics are shown below:

LOAD SIZE	TYPE	TIME/MIN.
3 Lbs.	Cotton	84
5 Lbs.	Cotton	126
3 Lbs.	P.P.	58
5 Lbs.	P.P.	80

Times indicated on the control dial are "heat-on" periods. The total cycle time is the dial setting plus the 12 minute cool down period.

## Switch Trim and Control Panel

Removal of the switch trim and control panel allows service of the timer, safety start switch, and door switch. Pull control knob to off and remove two Phillips screws. Remove switch trim by pulling right hand side forward.

## Control Panel Removal

To remove control panel, remove two screws, Figure 1. The door switch may also be serviced through this opening.

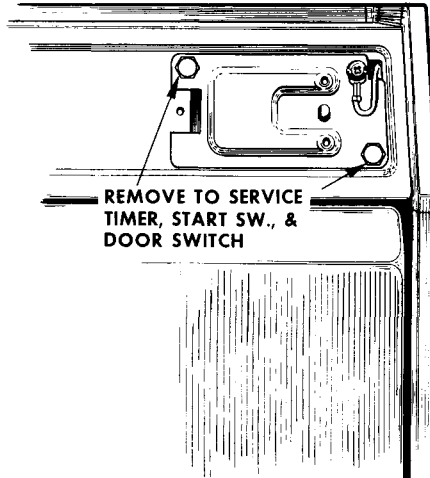
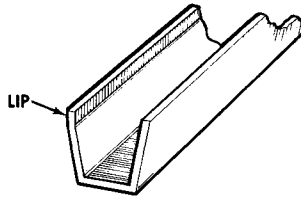


Figure 1 — Control Removal

## Trim Removal

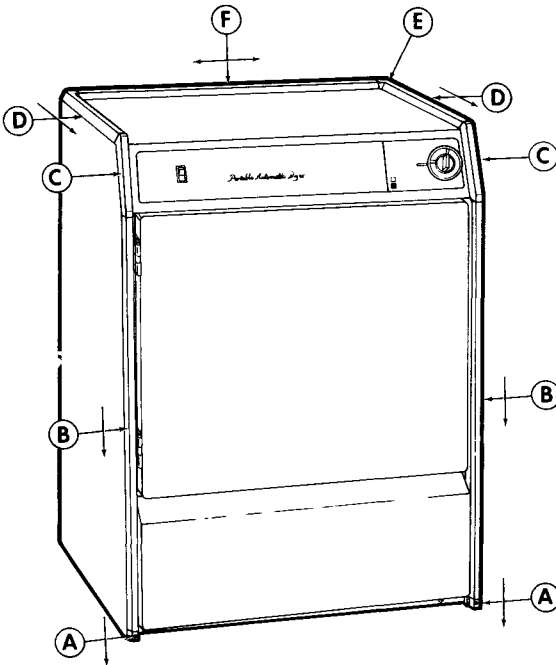
**NOTE:** Straight trim pieces have a lip which must be on the outside edge when reassembled, for proper fit to the cabinet sides, Figure 2.

# PORTABLE AUTOMATIC DRYER



**Figure 2**

To remove front and top trim, follow Steps 1 through 7 in Figure 3.

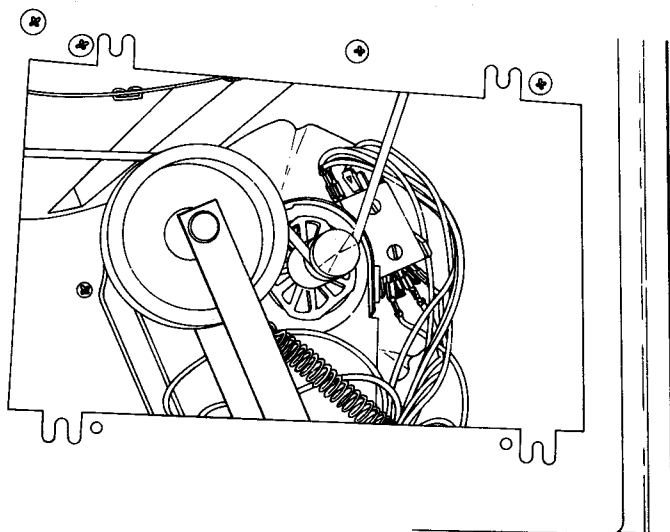


**Figure 3 — Trim Removal**

1. Remove Phillips screw and trim retainer. (A)
2. Slide trim strip (B) down and remove.
3. Remove Phillips screw and pull trim (C) away from panel.
4. Slide trim (D) forward to remove.
5. Remove Phillips screw and corner piece. (E)
6. Perform the above steps on opposite side.
7. Slide trim (F) to right or left to remove.

## Lower Trim Panel Removal

Removal of this panel gives access to a service panel, exposing the belt idler system, motor pulley and centrifugal switch. Remove two Phillips screws at the panel bottom, two inches in from each side. Open the dryer door and lift up on panel to release. **CAUTION:** When lifting or installing this panel, be careful the panel does not damage the paint immediately above the upper edge. Removing three screws from service panel gives access to the items shown in Figure 4.



**Figure 4 — Service Panel Removed**

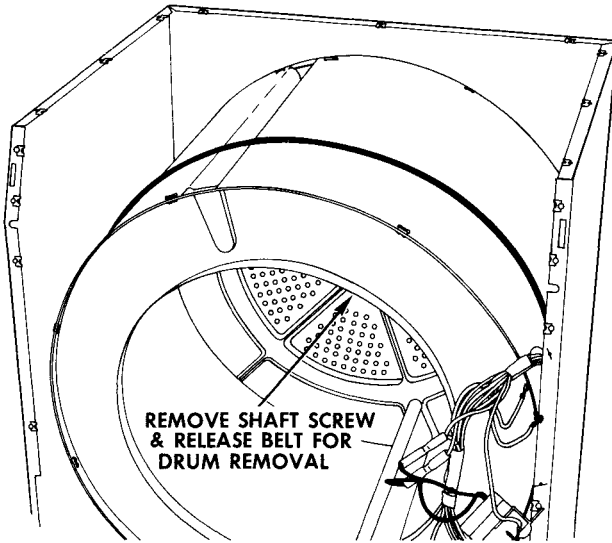
## Cabinet Top and Front Removal

Remove all Phillips screws exposed by removing trim strips. Remove switch trim. Release control panel and slip through hole to inside of front panel. The top and front panel may be removed exposing drum, Figure 5.

# PORTABLE AUTOMATIC DRYER

## Drum Removal

Release belt from idler pulley. Remove drum shaft screw, Figure 5, and remove drum.

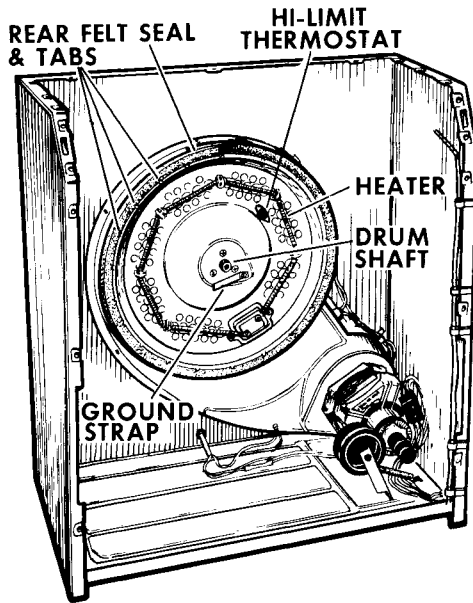


**Figure 5 — Drum Removal**

## Cabinet Interior

Removal of the drum exposes the heater assembly and motor blower assembly.

To replace the drum shaft, the complete duct assembly must be detached from the cabinet.



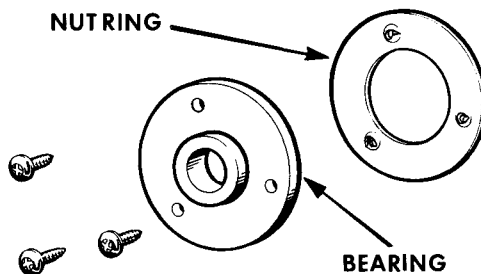
**Figure 6 — Cabinet Interior**

### **Drum Felt**

Both front and rear drum felt seals are secured with a wrap-around wire. When replacing felt, be sure wire is secured away from drum and behind felt retaining tabs, and that felt overlaps as shown.

### **Drum Bearing**

The drum bearing is secured to the drum by three Phillips screws and a nut ring. No lubrication is recommended on this bearing.



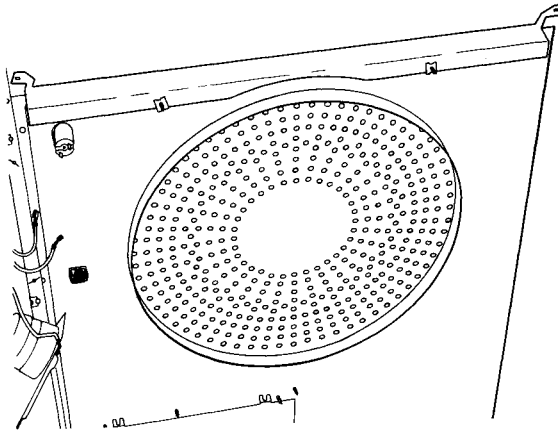
**Figure 7 — Drum Bearing**

### **Drum Slides**

Six teflon drum slides snap into the cabinet front. These slides do not require lubrication.



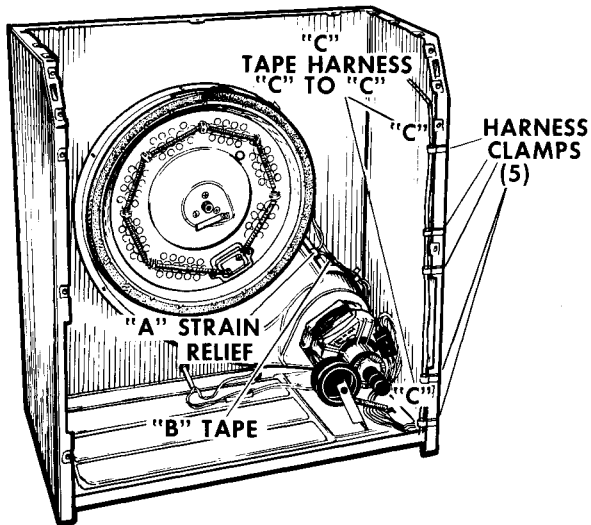
# PORTABLE AUTOMATIC DRYER



**Figure 8 — Drum Slides**

## Heater Replacement

To replace the heater, remove trim, cabinet front, top, and drum. Remove two nuts and flat washers from heater terminal block, Figure 9.



**Figure 9 — Heater Replacement**

Remove defective heater from insulators. Pre-stretch new heater to 27 inches. Thread new heater through insulators carefully, without additional stretching. Place heater ends on terminal block studs. Install flat washers and nuts and tighten securely.

## Service Notes

Heater wire strain relief (A) must be positioned so wires come out toward cabinet rear. Single thermostat lead (B) must be taped as shown. Wire harness must be taped as indicated and clamped, 5 clamps.

## High Limit Thermostat

To replace the high limit thermostat, remove three screws and access plate from cabinet rear.

## Electrical System

The dryer electrical system is shown on Page X-12. The heater operates continuously until timer contacts TB, — TA open for cool down. The cool down period in both Normal and Permanent Press is 12 minutes  $\pm$  2 minutes. The Fluff cycle is accomplished by using the cool down period of the Permanent Press cycle on the control dial. The high limit thermostat will cycle the heater if higher than normal temperatures occur.

## High Limit Test

The temperature limits of the Hi-Limit are - OPEN 165°F.  $\pm$  5°; CLOSE 135°F.  $\pm$  9°.

TO TEST, PROCEED AS FOLLOWS: UNPLUG DRYER.

1. Remove kick panel and service panel.
2. Jumper terminal 1 to terminal 2 on motor switch.
3. Plug dryer into 115 V outlet.
4. Open dryer door and advance the timer to 50 minute mark on dial.

The heater is now ON and should turn OFF in 1 minute to 1 minute 45 seconds. This may be observed by viewing the heater coil through the drum.

**CAUTION: WHEN THE TEST IS COMPLETED, REMOVE THE JUMPER ON THE MOTOR SWITCH.**

## Drive Motor

The drive motor is 1/12 H.P., 1725 R.P.M.'s. To test, remove the kick panel and service panel and proceed as follows:

# PORTABLE AUTOMATIC DRYER

## External Centrifugal Switch: Form "T" Motor

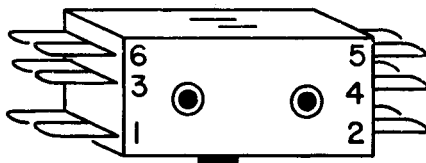


Figure 10

### Motor Testing

#### USE WX5X184 MOTOR TEST HARNESS:

1. Plug shorting connector block into test harness block.
2. Disconnect power to dryer; disconnect harness leads to motor.
3. Fasten three alligator clips to motor terminals as shown below:

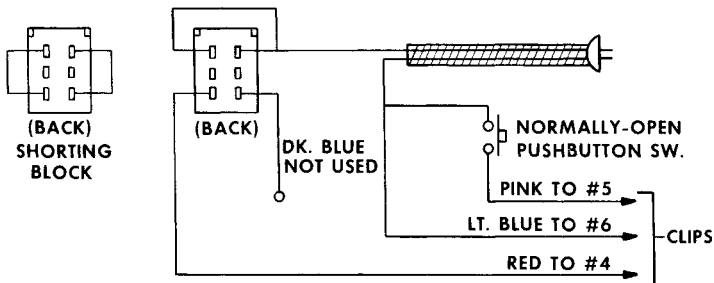


Figure 11

4. Plug in test cordset; momentarily depress pushbutton.
5. If motor runs it is okay. If not, replace motor. (NOTE: Centrifugal switch is bad if motor runs only when pushbutton is depressed.)
6. Check for continuity between terminals No. 1 and No. 2 with ohmmeter or test light while motor is running. Terminals 1-2 should be closed when motor is running, but open when motor stops.

External Centrifugal Switch: Form "V" Motor

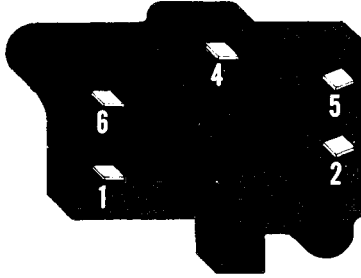
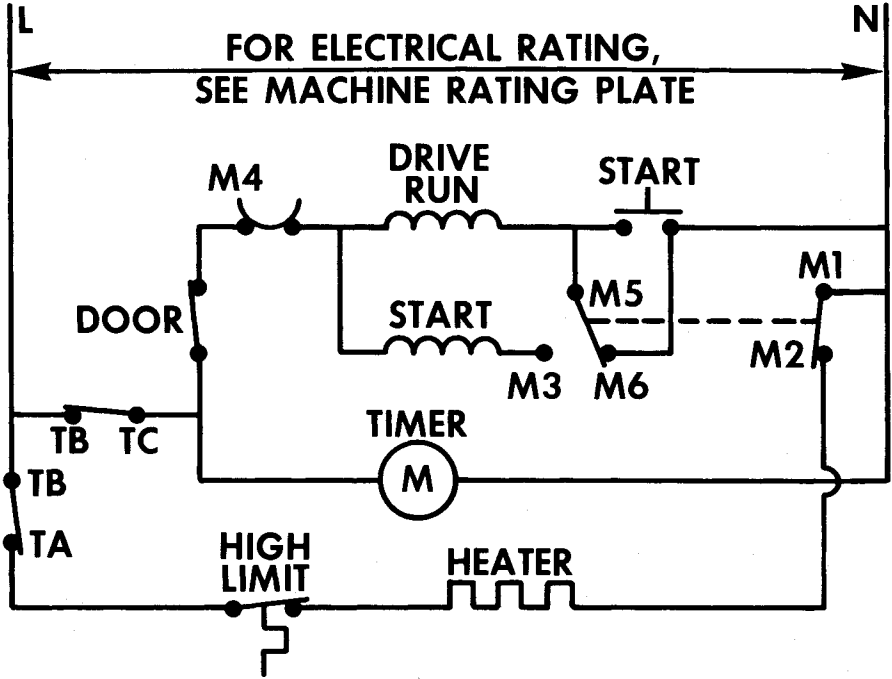


Figure 12

PORTABLE AUTOMATIC DRYER



TERMINAL LEGEND M- = DRIVE MOTOR  
T- = TIMER

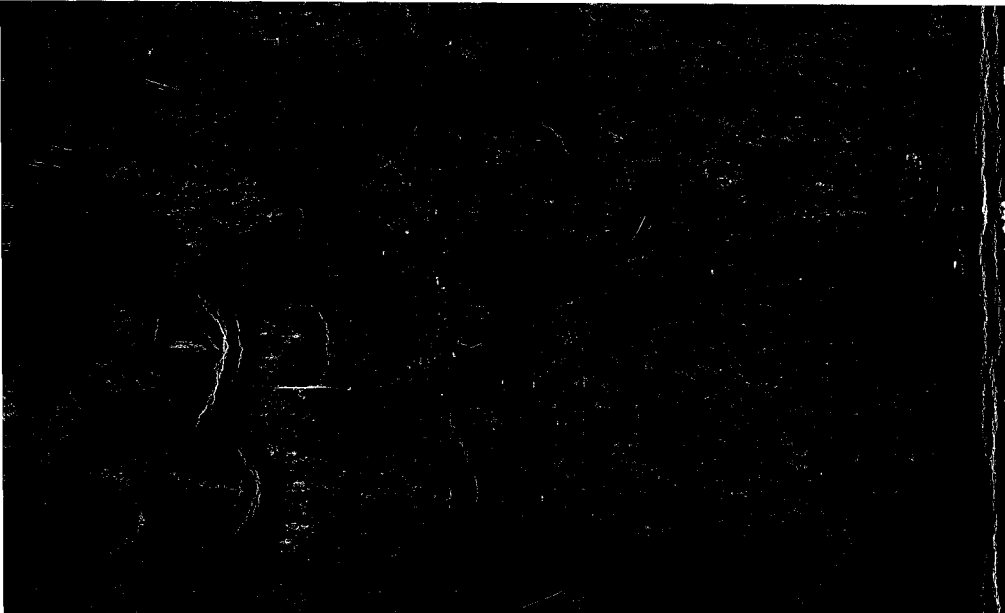
TIMER CAM CHART

	OFF	P. P.		OFF	NORMAL
		FLUFF	OFF		
TB-TA		■			■
TB-TC		■			■

LEGEND OPEN  CLOSED

TIMER SET FOR 'NORMAL' CYCLE.  
MACHINE: RUNNING

47X068



**GE Appliances**

---

General Electric Company  
Appliance Park  
Louisville, Kentucky 40225

Pub. No. 31-2100-6