



LG

Website: <http://www.LGservice.com> [For U.S.A]
www.lg.ca [For Canada]

ELECTRIC & GAS DRYER SERVICE MANUAL

CAUTION

READ THIS MANUAL CAREFULLY TO DIAGNOSE
TROUBLES CORRECTLY BEFORE OFFERING SERVICE.

**MODEL : DLE5977W/DLG5988W
DLE5977B/DLG5988B
DLE3777W/DLG3788W
DLE5977WM/DLG5988WM
DLE5977SM/DLG5988SM**



Apr. 2004 PRINTED IN KOREA

P/No.:3828EL3005A

IMPORTANT SAFETY NOTICE

The information in this service guide is intended for use by individuals possessing adequate backgrounds of electrical, electronic, and mechanical experience. Any attempt to repair a major appliance may result in personal injury and property damage. The manufacturer or seller cannot be responsible for the interpretation of this information, nor can it assume any liability in connection with its use.

WARNING !

To avoid personal injury, disconnect power before servicing this product. If electrical power is required for diagnosis or test purposes, disconnect the power immediately after performing the necessary checks.

RECONNECT ALL GROUNDING DEVICES

If grounding wires, screws, straps, clips, nuts, or washers used to complete a path to ground are removed for service, they must be returned to their original position and properly fastened.

WHAT TO DO IF YOU SMELL GAS:

- *Do not try to light a match, or cigarette, or turn on any gas or electrical appliance.*
- *Do not touch any electrical switches. Do not use any phone in your building.*
- *Clear the room, building or area of all occupants.*
- *Immediately call your gas supplier from a neighbor's phone. Follow the gas supplier's instructions carefully.*
- *If you cannot reach your gas supplier, call the fire department.*

IMPORTANT

Electrostatic Discharge (ESD)
Sensitive Electronics

ESD problems are present everywhere. ESD may damage or weaken the electronic control assembly. The new control assembly may appear to work well after repair is finished, but failure may occur at a later date due to ESD stress.

- Use an anti-static wrist strap. Connect wrist strap to green ground connection point or unpainted metal in the appliance.

- OR -

Touch your finger repeatedly to a green ground connection point or unpainted metal in the appliance.

- Before removing the part from its package, touch the anti-static bag to a green ground connection point or unpainted metal in the appliance.
- Avoid touching electronic parts or terminal contacts; handle electronic control assembly by edges only.
- When repackaging failed electronic control assembly in anti-static bag, observe above instructions.

CONTENTS

| | |
|--|----|
| 1. SPECIFICATIONS | 4 |
| 2. FEATURES AND BENEFITS | 6 |
| 3. INSTALLATION INSTRUCTIONS | 6 |
| 4. DRYER CYCLE PROCESS | 13 |
| 5. COMPONENT TESTING INFORMATION | 14 |
| 6. MOTOR DIAGRAM AND SCHEMATIC..... | 17 |
| 7. CONTROL LAY - OUT | 18 |
| 8. WIRING DIAGRAM | 19 |
| 9. DIAGNOSTIC TEST | 20 |
| 9-1. TEST 1 120VAC ELECTRICAL SUPPLY..... | 21 |
| 9-2. TEST 2 THERMISTOR TEST --- MEASURE WITH POWER OFF | 22 |
| 9-3. TEST 3 MOTOR TEST | 23 |
| 9-4. TEST 4 MOISTURE SENSOR | 24 |
| 9-5. TEST 5 DOOR SWITCH TEST | 25 |
| 9-6. TEST 6 HEATER SWITCH TEST - ELECTRIC TYPE..... | 26 |
| 9-7. TEST 7 GAS VALVE TEST - GAS TYPE | 27 |
| 10. CHANGE GAS SETTING (NATURAL GAS, PROPANE GAS) | 28 |
| 11. DISASSEMBLY INSTRUCTIONS | 30 |
| 12. EXPLODED VIEW | 37 |
| 12-1. CONTROL PANEL & PLATE ASSEMBLY | 37 |
| 12-2. CABINET & DOOR ASSEMBLY..... | 38 |
| 12-3-1. DRUM & MOTOR ASSEMBLY : ELECTRIC TYPE | 39 |
| 12-3-2. DRUM & MOTOR ASSEMBLY : GAS TYPE | 40 |
| 13. REPLACEMENT PARTS LIST..... | 41 |

1

SPECIFICATIONS

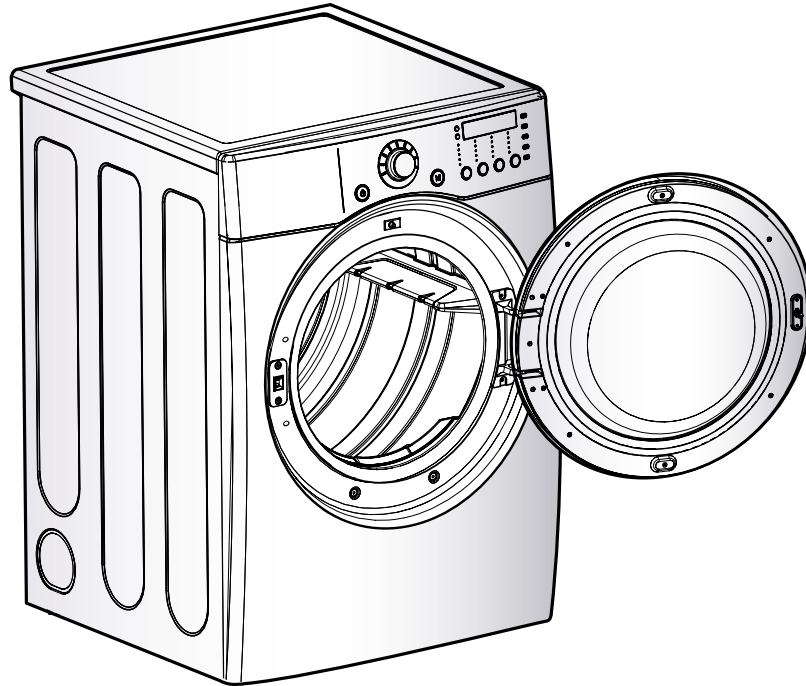

- Name : Electric and Gas Dryer
- Power supply : Please refer to the rating label regarding detailed information.
- Size : 68.6X98.3X76.1 (cm)
- Dryer capacity : IEC 7.3cu.ft.
- Weight : 126 (lbs)

Specifications are subject to change by manufacturer.

■ ACCESSORIES

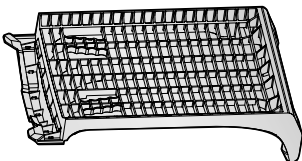

Dryer rack (1 each)

See page 6 for how to use.



Stacking kit (1 each)
Purchased Separately

See page 7 for how to use.

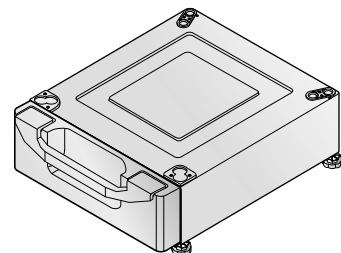

Pedestal (1 each)
Purchased Separately

See page 8 for how to use.

| ITEM | | DLE5977WM DLE5988WM DLE5977W DLG5988W | DLE5977B DLG5988B | DLE5977S DLG5988S DLE5977SM DLG5988SM | DLE3777W DLG3788W | REMARK |
|-----------------------------|-------------|--|----------------------|--|-------------------------|--------|
| Material & Finishes | Color | Blue White | Black | Titanium | Blue White | |
| | Top Plate | Porcelain | | | Painted | |
| | Door Trim | Chromate + STS Deco | | | Blue White | |
| POWER SUPPLY | | 120V / 240V 60Hz (26A) | | | | |
| ELECTRICITY CONSUMPTION | MOTOR | 250W (4.5A) | | | AC 120V | |
| | HEATER | 5400W (22.5A) | | | AC 240V (ELECTRIC TYPE) | |
| | LAMP | 15 W (125mA) | | | AC 120V | |
| | GAS VALVE | 13 W (110mA) x 2 | | | AC 120V(GAS TYPE) | |
| CONTROL TYPE | | Electronic | | | | |
| DRUM CAPACITY | | 7.3 cu.ft. | | | | |
| Weight (lbs) : Net / Gross | | 124 / 144 | | | | |
| No. of Programs | | 9 | | 7 | | |
| No. of Dry Options | | 5 | | 5 | | |
| No. of Temperature Controls | | 5 | | 5 | | |
| No. of Dry Levels | | 5 | | 5 | | |
| Sound levels | | High / Low / Off | | | | |
| Sensor | Moisture | Avaible | | | Electrode sensor | |
| | Temperature | Avaible | | | Termistor | |
| Reversible Door | | Avaible | | | | |
| Drum | | Stainless Steel | | | | |
| Dryer Rack | | Avaible | | | | |
| Child Lock | | Avaible | | | | |
| Interior Light | | Avaible | | | | |
| Product (WxHxD) | | 27" x 42 ³ / ₄ x 28 ¹ / ₃ | | | | |
| Packing (WxHxD) | | 29 ¹ / ₂ " x 44 ³ / ₄ x 30 ³ / ₄ | | | | |
| | | | | | | |

2

FEATURES AND BENEFITS

DLE5977W/DLG5988W/DLE5977B/DLG5988B/DLE5977WM/DLG5988WM/DLE5977SM/DLG5988SM

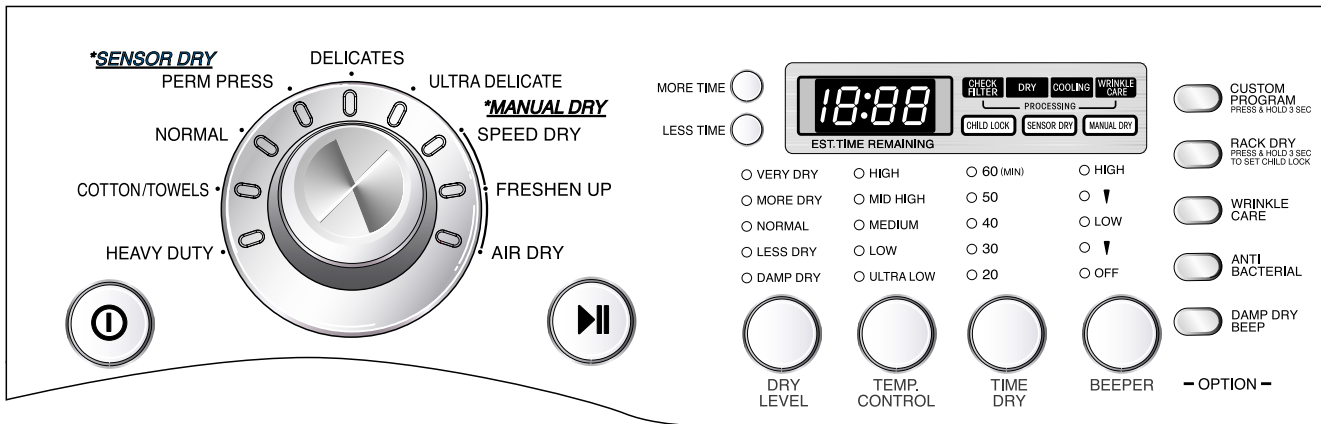

DLE3777W/DLG3788W



3

INSTALLATION INSTRUCTIONS

Dryer Rack Installation Instructions

1 **Open the door.**
Hold the dryer rack with both hands.

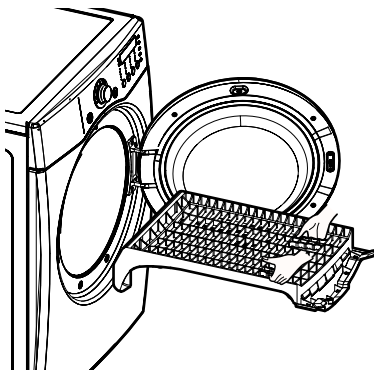

2 Put the dryer rack into the drum

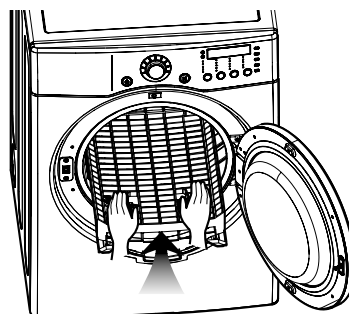

3 Make sure that dryer is evenly placed right onto the drum inside and door rim.

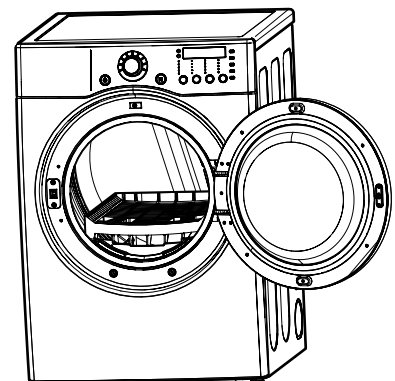

Stacking Kit Installation Instructions

To ensure safe and secure installation, please observe the instructions below.

WARNING

Do not attempt installation with one person.

Incorrect installation procedure can cause serious accidents and physical injuries.

The weight of the dryer and the height of installation makes the stacking procedure too risky for one person. This procedure should be performed by 2 or more experienced service personnel.

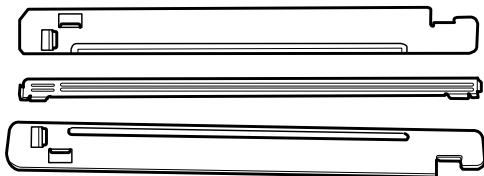

Stacking kit

1 Place washer firmly on a stable, even and solid floor as product installation instructions describes in owner's manual.

2 Peel protective paper off the tape from the stacking kit side bracket.

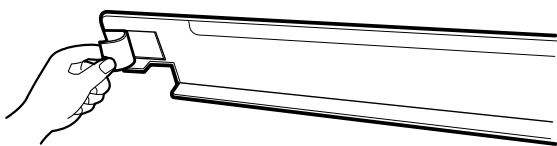

3 Fit the stacking kit side bracket firmly to the side of top plate by attaching the double-faced tape to top plate as picture shows.

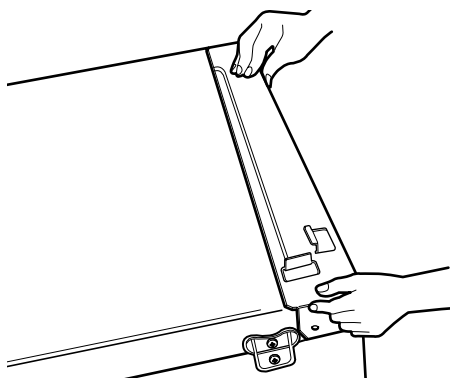

4 Secure stacking kit side bracket to the washer with a screw on the back of bracket. Repeat Steps 2, 3, 4 for the other side.

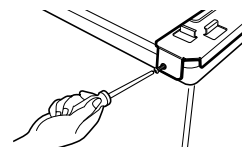

5 Place the dryer on top of the washer by fitting legs as shown in the picture. Avoid finger injuries - be careful not to pinch fingers between the washer and dryer. Slide washer slowly backwards to the stopper of kit.

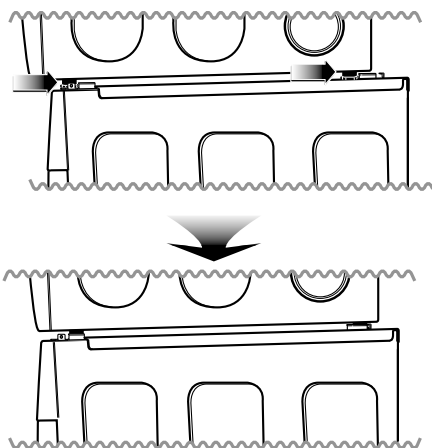

6 Insert the front stacking kit. Push the front stacking kit back to the stoppers of side stacking kit.

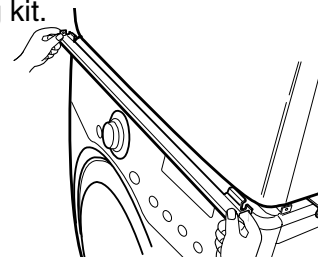

7 Screw both sides of the front kit.

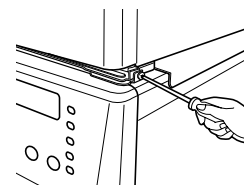

- Do not use stacking kit with a gas dryer in potentially unstable conditions like a mobile home.

Pedestal Installation Instructions

※ For washer, dryer, and combo LG 27

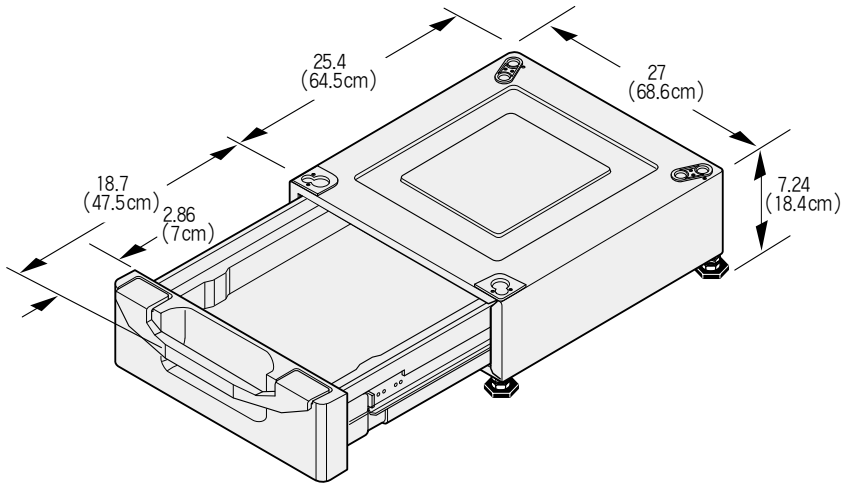

1 Remove pedestal, installation hardware, and instructions from the shipping carton.

2 Position dryer on top of the pedestal.

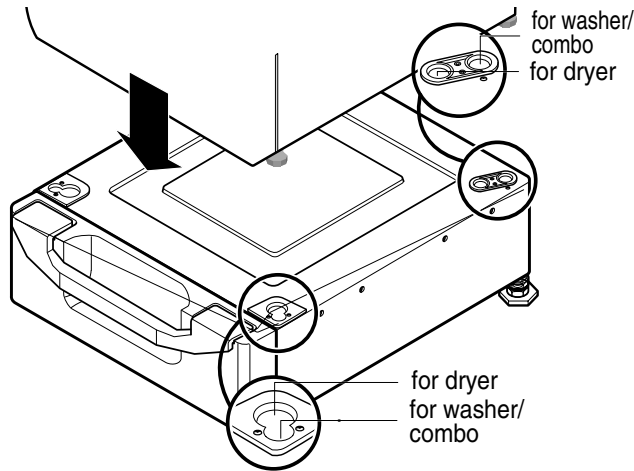

3 Remove the paper from the bracket.

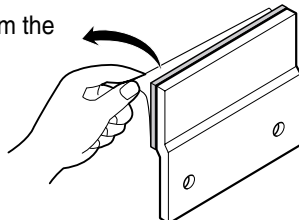

4 Attach the double-faced tape of the bracket to the dryer as shown so the bent parts of the brackets align with the edge and can be attached to the pedestal with screws.

NOTE : Attach the lower side first.

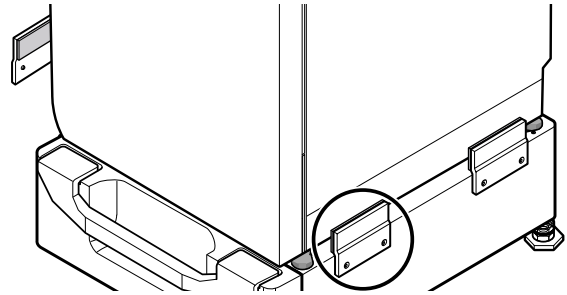

5 Be sure to press the adhesive parts of the brackets firmly to the appliance.

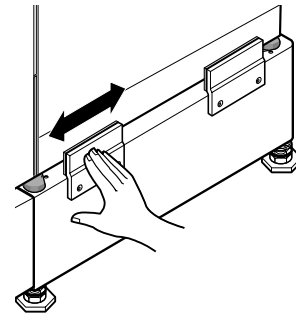

6 Install the eight (8) screws (supplied) to attach the brackets to the pedestal.

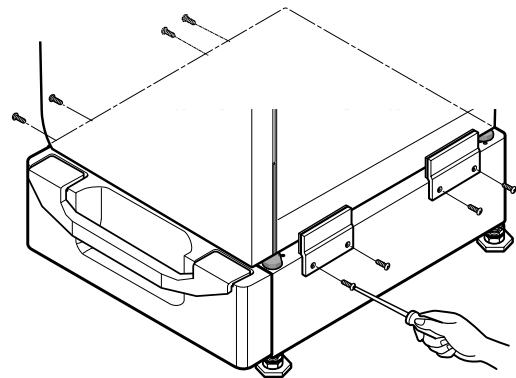

7 Move the dryer to the desired place.

NOTE : The appliance and pedestal assembly must be placed on a solid and level floor for proper operation. Adjust the legs of the appliance and pedestal by turning with a wrench. Then, adjust the lock unit toward the pedestal while holding the pedestal leg using a wrench.

Review the following options to determine the appropriate electrical connection for your home:

| | |
|---|--|
|  | <p>4-wire receptacle (NEMA type 14-30R)</p> |
|---|--|

Use the instructions at this section if your home has a 4-wire receptacle (NEMA type 14-30R) and you will be using a UL listed, 120/240 volt minimum, 30 amp, dryer power supply cord.

| | |
|---|--|
|  | <p>3-wire receptacle (NEMA type 10-30R)</p> |
|---|--|

Use the instructions at this section if your home has a 3-wire receptacle (NEMA type 10-30R) and you will be using a UL listed, 120/240 volt minimum, 30 amp, dryer power supply cord.

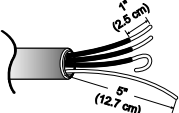
| | |
|---|-----------------------------|
|  | <p>4-wire direct</p> |
|---|-----------------------------|

If this type is available at your home, you will be connecting to a fused disconnect or circuit breaker box

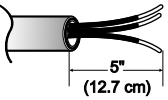
| | |
|---|-----------------------------|
|  | <p>3-wire direct</p> |
|---|-----------------------------|

If this type is available at your home, you will be connecting to a fused disconnect or circuit breaker box

4-wire connection : Direct wire

Important : use 4-wire connection in the places such as mobile homes and areas where 3-wire connections is not available.

Prepare minimum 5ft(1.52m) of length in order for dryer to be replaced.

First, peel 5 inch (12.7cm) of covering material from end. Make a 5 inch of ground wire bared. After cutting 1 1/2 inch (3.8cm) from 3 other wires, peel insulation back 1inch (2.5cm). Make ends of 3 wires a hook shape.

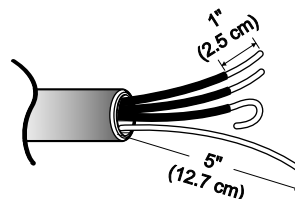

Then, put the hooked shape end of the wire under the screw of the terminal block(hooked end facing rightward) and pinch the hook together and screw tightly.

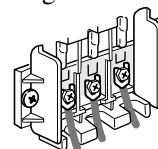

1. Connect neutral wire(white) of power cord to center terminal block screw.
2. Connect red and black wire to the left and right terminal block screws.
3. Connect ground wire(green) of power cord to external ground screw and move neutral ground wire of appliance and connect it to center screw.
4. Make sure that the strain relief screw is tightened. and be sure that all terminal block nuts are on tight and power cord is in right position.

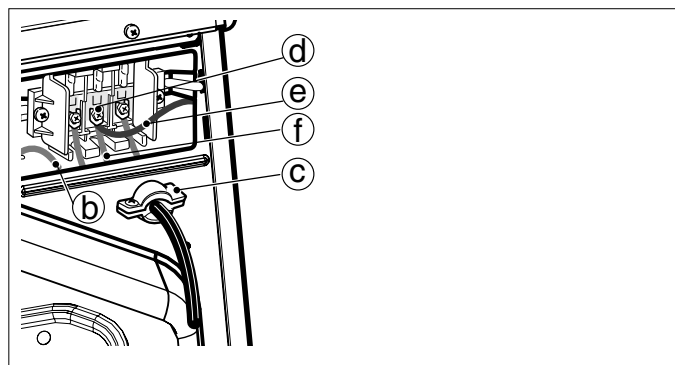

3-wire connection : Direct wire

Important : use 3-wire connection in the places such as mobile homes and areas where 3-wire connections is not available.

Prepare minimum 5ft(1.52m) of length in order for dryer to be replaced.

First, peel 3 1/2 inch (8.9cm) of covering material from end and bare 1 inch from the ends.

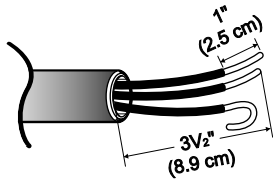

Then, put the hooked shape end of the wire under the screw of the terminal block(hooked end facing rightward) and pinch the hook together and screw tightly.

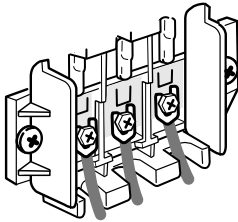

1. Connect neutral wire(white) of power cord to center terminal block screw.
2. Connect red and black wire to the left and right terminal block screws.
3. Make sure that the strain relief screw is tightened and be sure that all terminal block nuts are on tight and power cord is in right position.

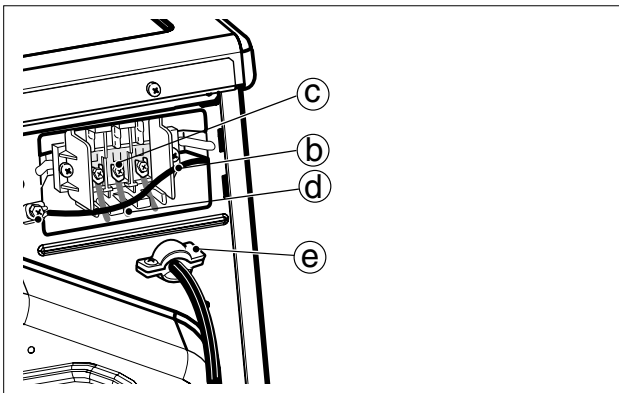

Option 1: 4-wire connection with a Power supply cord.

- If your local codes or ordinances do not allow the use of a 3 wire connection, or you are installing your dryer in a mobile home, you must use a 4-wire connection.

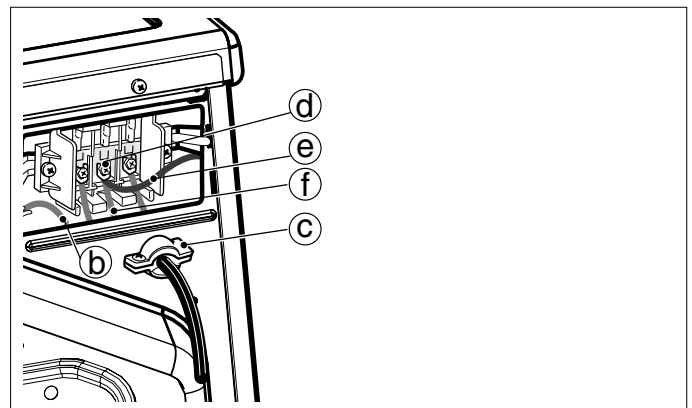
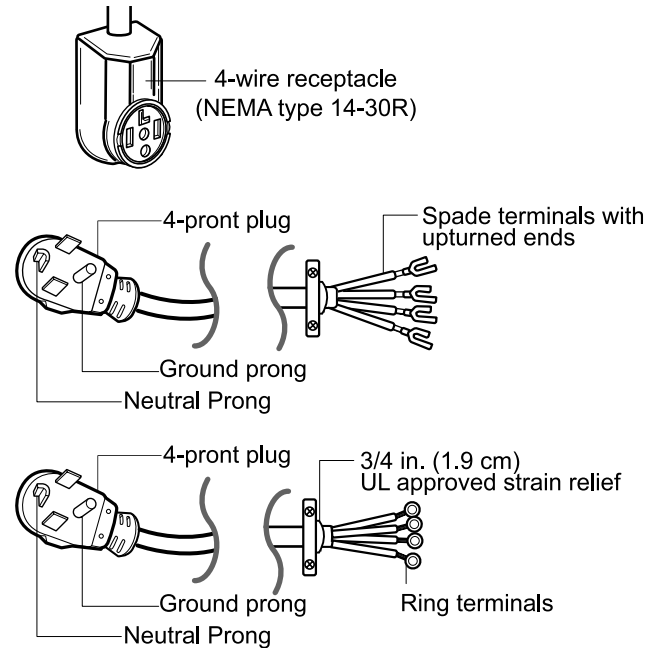

1. Connect neutral wire(white) of power cord to center terminal block screw.
2. Connect red and black wire to the left and right terminal block screws.
3. Connect ground wire(green) of power cord to external ground screw and move neutral ground wire of appliance and connect it to center screw.
4. Make sure that the strain relief screw is tightened. and be sure that all terminal block nuts are on tight and power cord is in right position.

Option 2: 3-Wire Connection with a Power Supply Cord

If your local codes or ordinances permit the connection of a frame-grounding conductor to the neutral wire, use these instructions. If your local codes or ordinances do not allow the connection of a frame-grounding conductor to the neutral wire, use the instructions under **Section 3: Optional 3-wire connection.**

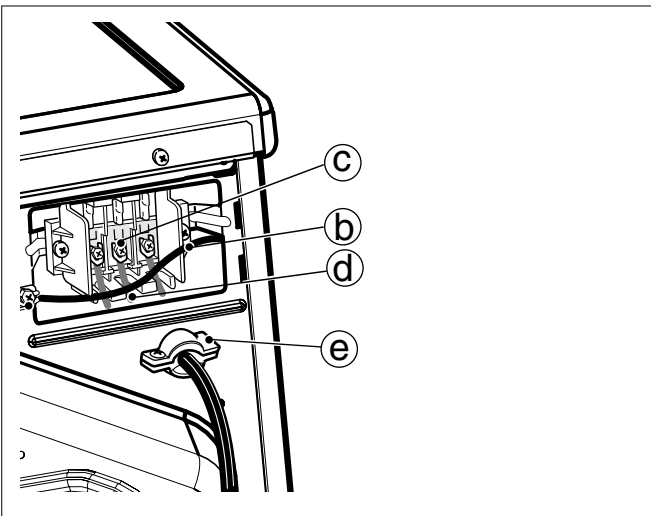
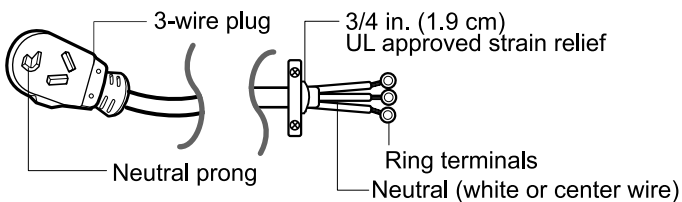
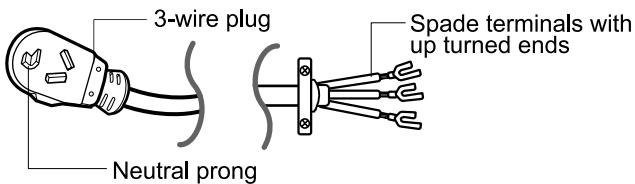
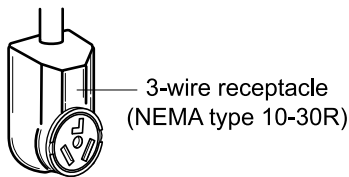

Option 3: Optional 3-wire connection.

- If your local codes or ordinances do not allow the connection of a frame-grounding conductor to the neutral wire, use the instructions under this section.

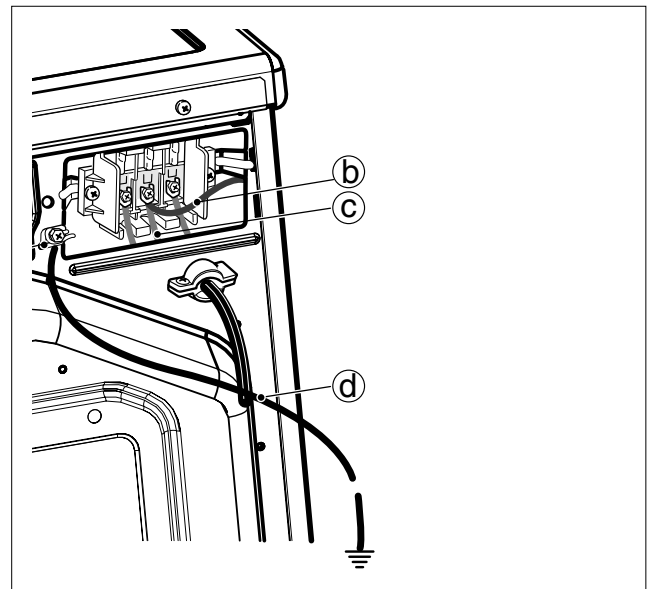
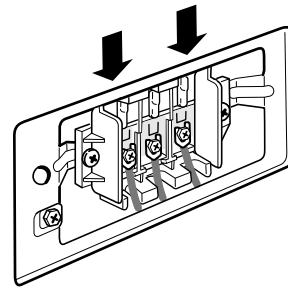

1. Connect neutral wire(white) of power cord to center terminal block screw.
2. Connect ground wire of appliance and neutral wire of power cord to center terminal block screw.
3. Connect red and black wire to the left and right terminal block screws.
4. Make sure that the strain relief screw is tightened, and be sure that all terminal block nuts are on tight and power cord is in right position.
5. Connect a independent ground wire from external ground connector to proper ground.

3-2. Connect Gas Supply Pipe (Gas Dryer ONLY)

For further assistance, refer to section on **Gas Requirements**.

1. Make certain your dryer is equipped for use with the type of gas in your laundry room. Dryer is equipped at the factory for Natural Gas with a 3/8" N.P.T. gas connection.
2. Remove the shipping cap from the gas connection at the rear of the dryer. Make sure you do not damage the pipe thread when removing the cap.
3. Connect to gas supply pipe using a new flexible stainless steel connector.
4. Tighten all connections securely. Turn on gas and check all pipe connections (internal & external) for gas leaks with a non-corrosive leak detection fluid.
5. For L.P. (Liquefied Petroleum) gas connection, refer to section on Gas Requirements.

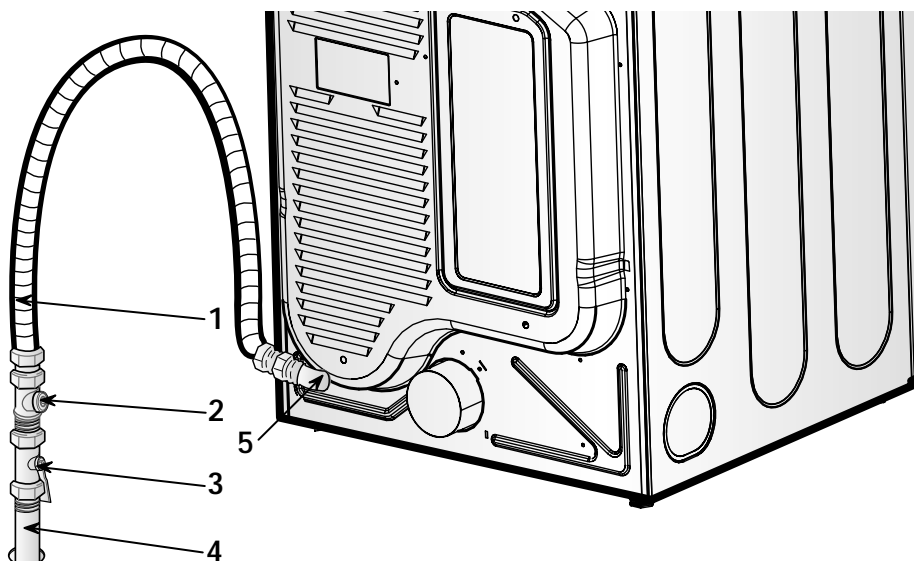

- 1 New Stainless Steel Flexible Connector - Use only if allowed by local codes (Use Design A.G.A. Certified Connector)
- 2 1/8" N.P.T. Pipe Plug (for checking inlet gas pressure)
- 3 Equipment Shut-Off Valve-Installed within 6' (1.8 m) of dryer
- 4 Black Iron Pipe
Shorter than 20' (6.1 m) - Use 3/8" pipe
Longer than 20' (6.1 m) - Use 1/2" pipe
- 5 3/8" N.P.T. Gas Connection

4

DRYER CYCLE PROCESS

| Cycle | | Default | | | Conditions of operation and termination | | | | |
|----------------------|----------------|--------------|-----------|--------------|---|--------------|--------------|------------------------------------|----------------|
| | | Temp-erature | Dry Level | Display time | Drying | | Cooling | | Wrinkle care |
| | | | | | Electro-sensor | Temp-Control | Default time | Temp-Control** | |
| Sensor Dry * | HEAVY DUTY | HIGH | (Normal) | 54min | Saturation | 68±4°C | (5min) | 47±5°C | 3Hr |
| | COTTON/TOWELS | MID HIGH | (Normal) | 55min | Saturation | 66±4°C | (5min) | 47±5°C | |
| | NORMAL | MEDIUM | (Normal) | 41min | Saturation | 60±4°C | (5min) | 47±5°C | |
| | PERM PRESS | LOW | (Normal) | 36min | Saturation | 52±3°C | (5min) | 47±5°C | |
| | DELICATES | LOW | (Normal) | 32min | Saturation | 52±3°C | (5min) | 38±5°C | |
| | ULTRA DELICATE | ULTRA LOW | (Normal) | 34min | Saturation | 45±3°C | (5min) | 38±5°C | |
| Manual Dry ** | SPEED DRY | (HIGH) | - | 25min | Saturation | (70±5°C) | (5min) | (47±5°C) | 3Hr |
| | FRESHEN UP | (MID HIGH) | - | 20min | Saturation | (66±5°C) | (5min) | (47±5°C) | |
| | AIR DRY | - | - | 30min | Saturation | No heater | N/A | N/A | |
| Load | | Motor | | | | | | | Off Time: 6min |
| | | | | | Heater | | | | |
| | | | | | | | | Temperature Control for each cycle | |

* Sensor dry : “Dry Level” is set by users.

** Manual dry : “Temperature control” is set by users.

Default settings can be adjusted by users.

5

COMPONENT TESTING INFORMATION

CAUTION When checking the Component, be sure to turn the power off, and do voltage discharge sufficiently.

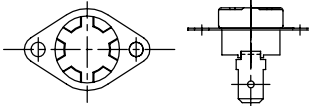
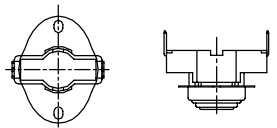
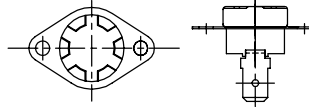
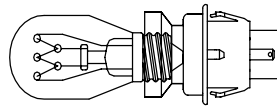
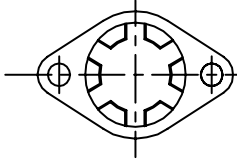
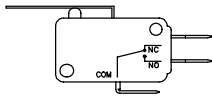
| Component | Test Procedure | Check result | Remark |
|---|--|--|---|
| 1. Thermal cut off  • Check Top Marking : N130 | Measure resistance of terminal to terminal ① Open at $266 \pm 12^{\circ}\text{F}$ ($130 \pm 7^{\circ}\text{C}$) ② Auto reset -31°F (-35°C) Same shape as Outlet Thermostat. | If thermal fuse is open must be replaced ① Resistance value $\approx \infty$ ② Continuity ($250^{\circ}\text{F} \downarrow$) $< 1\Omega$ | <ul style="list-style-type: none"> • Heater case-Safety • Electric type |
| 2. Hi limit Thermostat (Auto reset)  | Measure resistance of terminal to terminal ① Open at $257 \pm 9^{\circ}\text{F}$ ($125 \pm 5^{\circ}\text{C}$) ② Close at $221 \pm 9^{\circ}\text{F}$ ($105 \pm 5^{\circ}\text{C}$) | ① Resistance value $\approx \infty$ ② Resistance value $< 5\Omega$ | <ul style="list-style-type: none"> • Heater case - Hi limit • Electric type |
| 3. Outlet Thermostat (Auto reset)  • Check Top Marking : N85 | Measure resistance of terminal to terminal ① Open at $185 \pm 9^{\circ}\text{F}$ ($85 \pm 5^{\circ}\text{C}$) ② Close at $149 \pm 9^{\circ}\text{F}$ ($65 \pm 5^{\circ}\text{C}$) Same shape as Thermal cut off. | ① Resistance value $\approx \infty$ ② Resistance value $< 5\Omega$ | <ul style="list-style-type: none"> • Blow housing - Safety • Electric type |
| 4. Lamp holder  | Measure resistance of terminal to terminal | Resistance value : $80\Omega \sim 100\Omega$ | |
| 5. Door switch  | Measure resistance of the following terminal 1) Door switch knob : open ① Terminal : "COM" - "NC" (1-3) ② Terminal : "COM" - "NO" (1-2) 2) Door switch push : push ① Terminal : "COM" - "NC" (1-3) ② Terminal : "COM" - "NO" (1-2) | ① Resistance value $< 1\Omega$ ② Resistance value $\approx \infty$ ① Resistance value $\approx \infty$ ② Resistance value $< 1\Omega$ | The state that Knob is pressed is opposite to Open condition. |
| 6. Idler switch  | Measure resistance of the following terminal : "COM - NC" | 1. lever open ① Resistance value $< 1\Omega$ 2. Lever push (close) ② Resistance value $\approx \infty$ | |

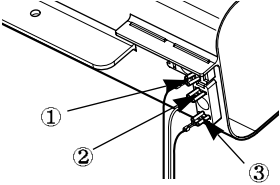
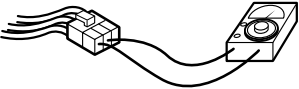
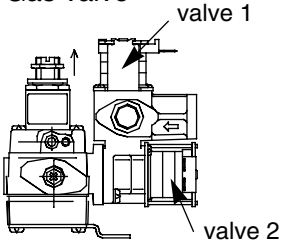
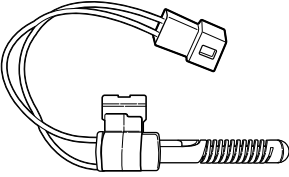
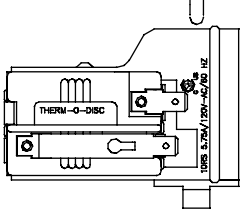
| Component | Test Procedure | Check result | Remark |
|---|--|--|---|
| 7. Heater  | Measure resistance of the following terminal ① Terminal : 1 (COM) - 2 ② Terminal : 1 (COM) - 3 ③ Terminal : 2 - 3 | ① Resistance value : 10Ω ② Resistance value : 10Ω ③ Resistance value : 20Ω | <ul style="list-style-type: none"> • Electric type |
| 8. Thermistor  | Measure resistance of terminal to terminal Temperature condition : 58°F ~ (10~40°C) 58°F ~ 104F (10~40°C) | Resistance value : 10Ω | <ul style="list-style-type: none"> • Heater case - Hi limit • Electric type |
| 9. Motor | | | <ul style="list-style-type: none"> • See Page 13 |
| 10. Gas valve  | Measure resistance of the following terminal ① Valve 1 terminal ② Valve 2 terminal | ① Resistance value : > 1.5kg ~ ② Resistance value : > 1.5~2.5kg | <ul style="list-style-type: none"> • Gas type |
| 11. Igniter  | Measure resistance of terminal to terminal | Resistance value : 100~800Ω | <ul style="list-style-type: none"> • Gas type |
| 12. Frame Detect  | Measure resistance of terminal to terminal ① Open at 370°F ((Maximum) ② Close at 320°F | ① Resistance value ≒ ∞ ② Resistance value < 1Ω | <ul style="list-style-type: none"> • Gas type |

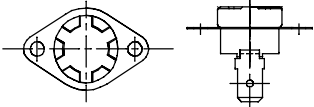
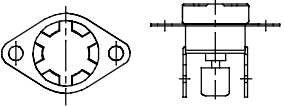
| Component | Test Procedure | Check result | Remark |
|---|---|---|--|
| <p>13. Outlet Thermostat (Auto reset)</p>  <p>• Check Top Marking : N95</p> | <p>Measure resistance of terminal to terminal</p> <p>① Open at $203 \pm 7^{\circ}\text{F}$ ($95 \pm 5^{\circ}\text{C}$) ② Close at $158 \pm 9^{\circ}\text{F}$ ($70 \pm 5^{\circ}\text{C}$)</p> | <p>① Resistance value $\neq \infty$ ② Continuity $< 1\Omega$</p> | <ul style="list-style-type: none"> • Gas type • Gas funnel |
| <p>13. Outlet Thermostat (Manual reset)</p>  <p>• Check Top Marking : N100</p> | <p>Measure resistance of terminal to terminal</p> <p>① Open at $212 \pm 12^{\circ}\text{F}$ ($100 \pm 7^{\circ}\text{C}$) ② Manual reset</p> | <p>If thermal fuse is open must be replaced</p> <p>① Resistance value $\neq \infty$ ② Continuity $< 1\Omega$</p> | <ul style="list-style-type: none"> • Gas type • Gas funnel |

6

MOTOR DIAGRAM AND SCHEMATIC

NOTE When checking Component, be sure to turn Power off, then do voltage discharge sufficiently.

■ Contact On / Off by Centrifugal Switch

| Terminal No | | ① | ② | ③ | ④ | ⑤ | ⑥ | Remark |
|-------------|------------|---|---|---|---|---|---|--------------------------|
| Mode | Resistance | | | | | | | |
| Motor STOP | 2 ~ 3Ω | | | | ● | ● | | Motor |
| | ≒ ∞ | ● | ● | | | | | Heater (Electric Models) |
| | ≒ ∞ | | | ● | | | ● | Gas Valve (Gas Models) |
| Motor RUN | 3 ~ 5Ω | | | | ● | ● | | Motor |
| | < 1Ω | ● | ● | | | | | Heater (Electric Models) |
| | < 1Ω | | | ● | | | ● | Gas Valve (Gas Models) |

..... Open
 ——— Close

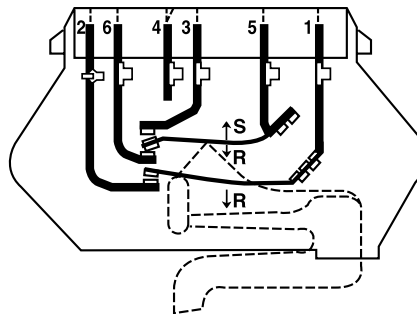

SWITCH SHOWN IN START POSITION

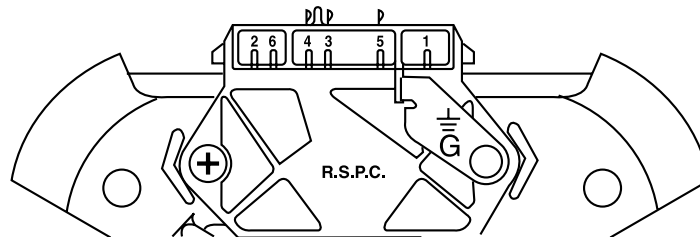

■ STOP MODE
 (When Motor does not operate)

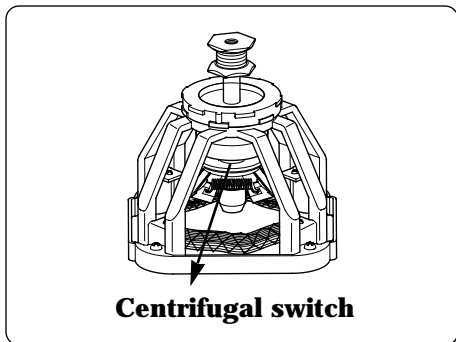

■ RUN MODE
 (Motor operates)

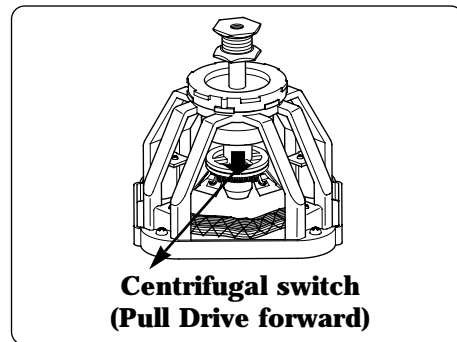

PWB ASSEMBLY DISPLAY LAY-OUT

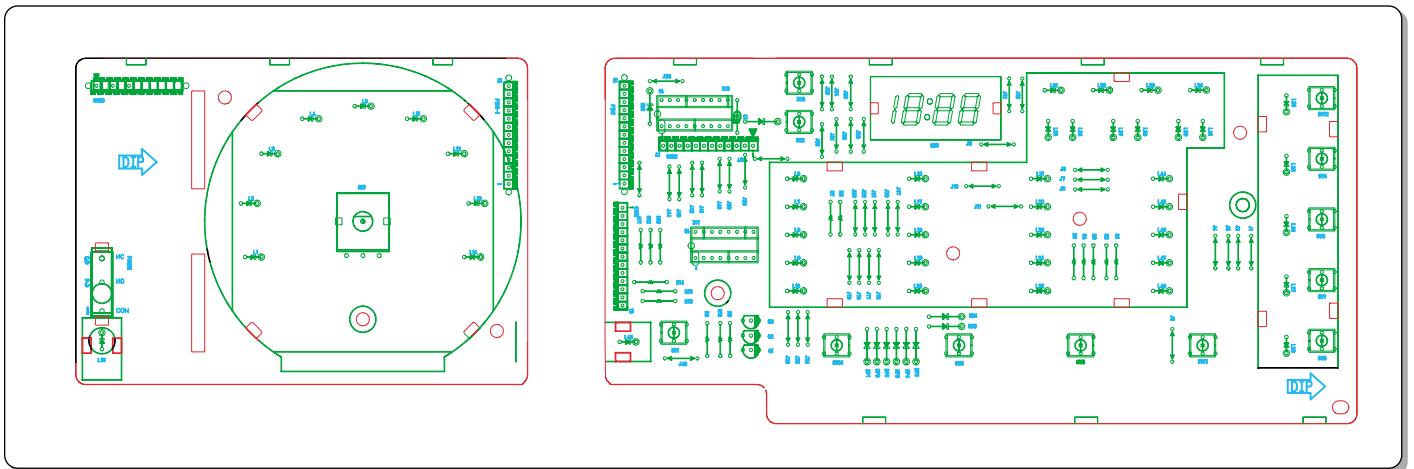

※ MODEL DISPLAY AS DIAGNOSTIC TEST

| MODEL | OPTION PART | | | | | | LED DISPLAY | P/No |
|--------------------------|-------------|------|------|------|------|------|-------------|-------------|
| | OP 1 | OP 2 | OP 3 | OP 4 | OP 5 | OP 6 | | |
| DLE5977WM/SM, DLE5977W/B | X | X | X | O | X | X | 18:FO | 6871EC1115A |
| DLG5988WM/SM, DLG5988W/B | X | X | O | O | X | X | 19:FO | 6871EC1115B |
| DLE3777W | X | X | X | X | X | X | 18:F1 | 6871EC1115C |
| DLG3788W | X | X | O | X | X | X | 19:F1 | 6871EC1115D |

PWB ASSEMBLY LAY-OUT

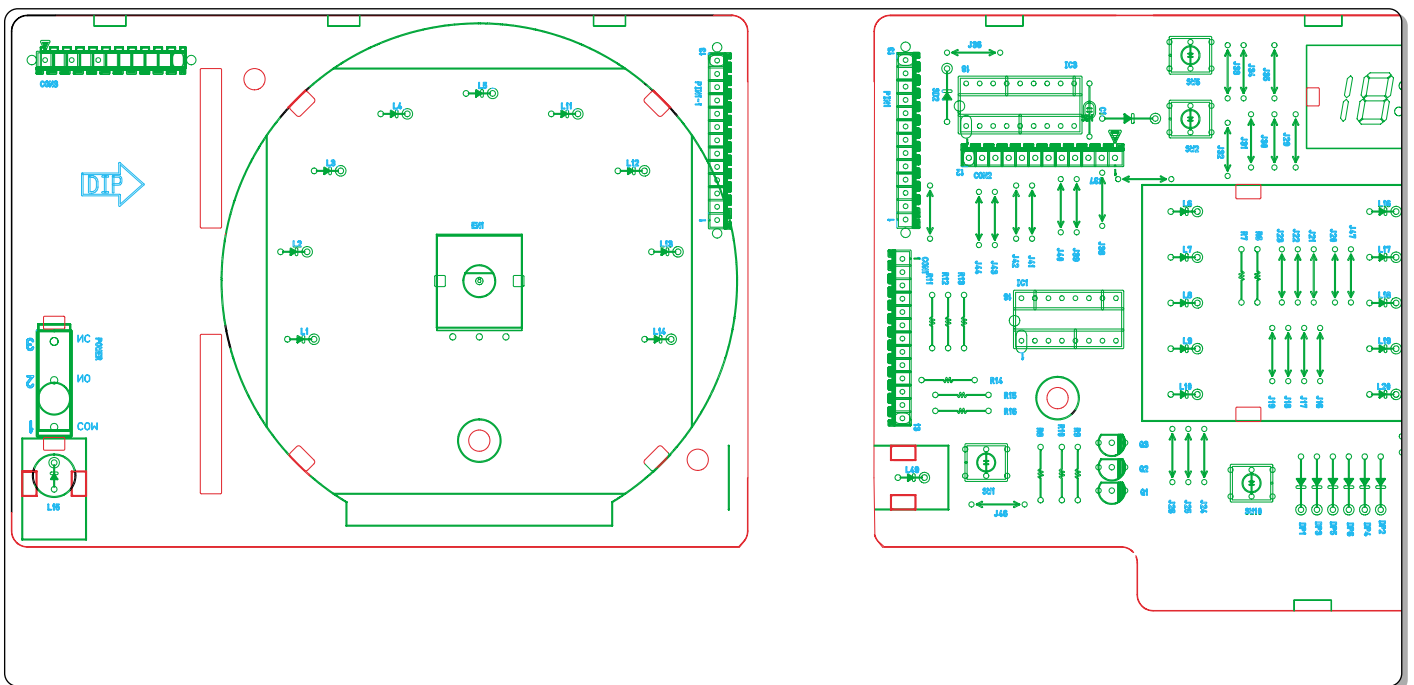

ELECTRIC DRYER WIRING DIAGRAM

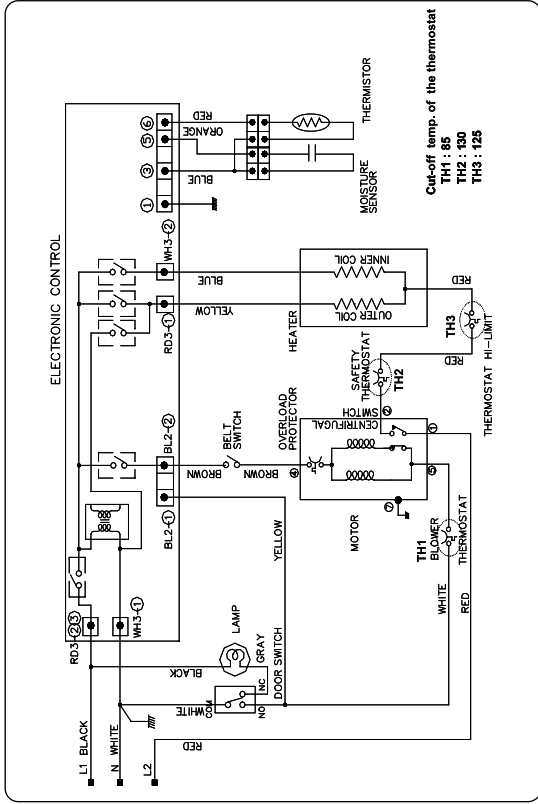

RLM ELECTRIC DRYER WIRING DIAGRAM

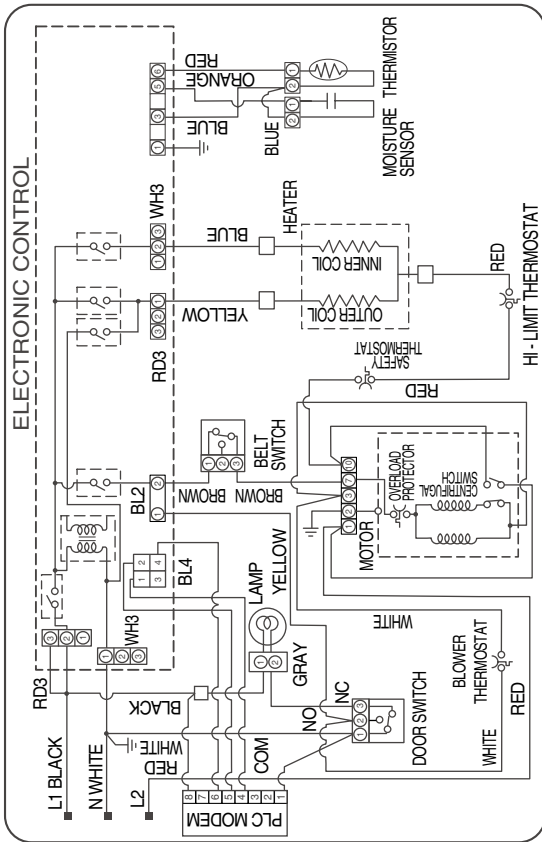

GAS DRYER WIRING DIAGRAM

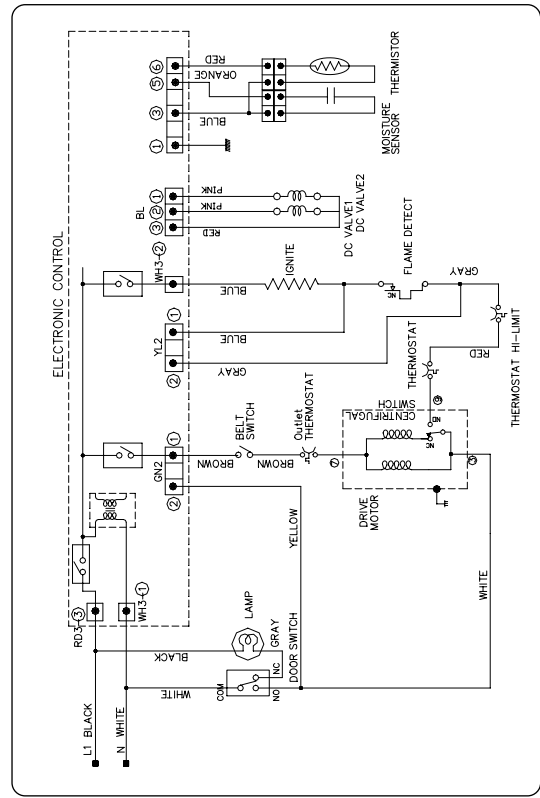

RLM GAS DRYER WIRING DIAGRAM

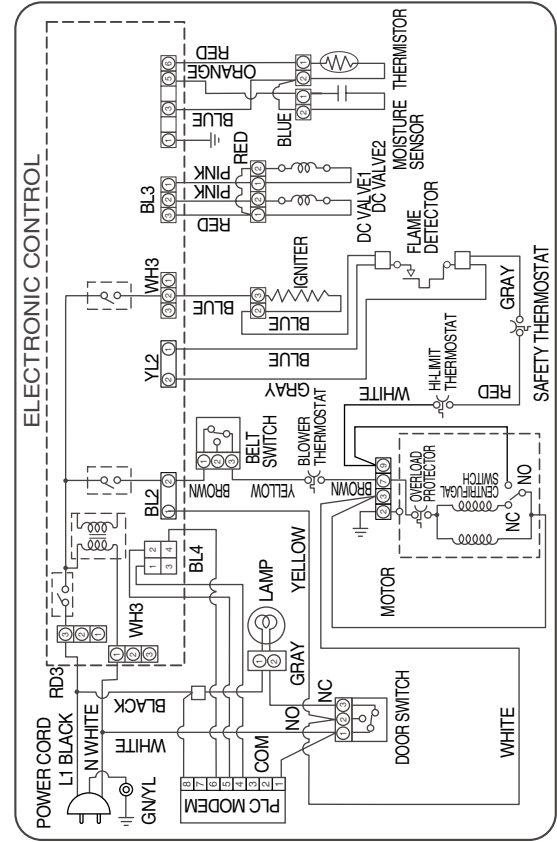

1. This TEST should be used for Factory test /Service test. Do not use this DIAGNOSTIC TEST other than specified.
2. Activating the Heater manually with the Door open may trip the Thermostat attached to the Heater, therefore do not activate it manually. (Do not press the door switch to operate the heater while the door is open)

■ ACTIVATING THE DIAGNOSTIC TEST MODE

1. Unit must be in Standby (unit plugged in, display off)
2. Press "POWER" while pressing "MORE TIME", and "LESS TIME" simultaneously.

| Pressing the "START/PAUSE" button | CHECKING ACTION | DISPLAY | CHECKING POINT | REMARK |
|---|---|---|--|----------------------------------|
| None | Electric control & Temperature sensor | | Won't power up Defective LED | See test 1 Display : See page |
| | | | Thermistor open | See test 2 |
| | | | Thermistor close | |
| Once | Motor | 70 ~ 239 Measured Moisture Value. | Motor runs | See test 3 |
| | | | Displays Moisture Sensor Operation: If moisture sensor is contacted with damp cloth. The display number is below 180, in normal condition. | See test 4 |
| Twice | <ul style="list-style-type: none"> ■ ELECTRIC TYPE Motor + Heater 1 (2700W) ■ GAS TYPE Motor + Valve | Current Temp. | <ul style="list-style-type: none"> ■ ELECTRIC TYPE : Heater runs ■ GAS TYPE : GAS Valve runs (Display the Temperature of Inside drum.) | Gas valve See test 7 |
| 3 times | <ul style="list-style-type: none"> ■ ELECTRIC TYPE Motor + Heater 1 +Heater 2 (5400W) ■ GAS TYPE Motor Type | Current Temp. (5 ~ 70) | | |
| 4 times | Control Off | | Auto Off | |
| During check, If the door is open. | Motor & Heater Off + Lamp On + Buzzer beeps seven times | | Door switch | See test 6 |
| | | | Lamp | |
| During check, If the door is closed. | Motor on & Heater Off + Lamp Off | 70 ~ 239 | <ul style="list-style-type: none"> • Press Start button 1 time and then open the door. Proceed again with the step 1 (by pressing start 1 time), step 2 (by pressing start 2 times), step 3 (by pressing start 3 times) and step 4 (by pressing start 4 times) in sequence. • Press Start 2 times and then open the door. Proceed again from the step 1 all the way to the step 4. • Press Start 3 times and then open the door. Proceed with the step 1 and skip the step 2 and press step 3 twice and finish with step 4 by making sure the all the electric devices shut off in the end. | |

■ Test 1 120VAC Electrical supply

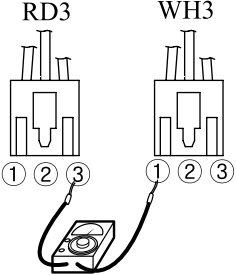
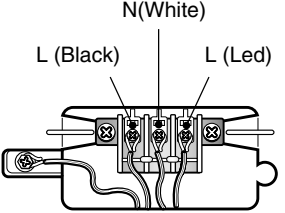
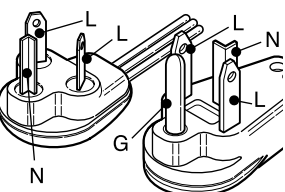
| | | |
|---|---|---|
| <p>Caution</p> | <p>When measuring power, be sure to wear insulated gloves, to and avoid an electric shock.</p> | |
| <p>Trouble Symptom</p> | <p>No power was applied to Controller. (LED, Display off)</p> | |
| <p>Measurement Condition</p> | <p>With Dryer Power On; Connector linked to Controller.</p> | |
|  | <p>Check the outlet, is the voltage 110V ~ 125V AC?</p> | <p>NO</p> <ul style="list-style-type: none"> • Check the fuse or circuit breaker. |
| <p>YES</p> | | |
|  | <p>Check if the voltage measured between Connector “RD3-③” (Black) linked to the Controller and “WH3-①”(White) is 110V ~ 125V?</p> | <p>NO</p> <ul style="list-style-type: none"> • Check if Power Cord is properly connected. |
| <p>YES</p> | | |
|  | <p>① Check if the Controller wire is disconnected. ② Check if Terminal Block and Power Cord are connected (Check Plug). - Does Power Cord N(Natural) line match to Terminal Center N(Natural) line?</p> | <p>NO</p> <ul style="list-style-type: none"> • Reconnect the controller. |
| <p>YES</p> | | |
|  | <p>Replace controller.</p> | |

■ Test 2 Thermistor Test --- Measure with Power Off

| | |
|------------------------------|---|
| Caution | Before measuring resistance, be sure to turn Power off, and do voltage discharge. (When discharging, contact the metal plug of Power cord with the Ground.) |
| Trouble Symptom | <ol style="list-style-type: none"> ① During Diagnostic Test, tE1 and tE2 Error occur. ② During operation, Heater would not turn off, or remains on. ③ Difference between actual and sensed temperature is significant. |
| Measurement Condition | After turning Power off, measure the resistance. |

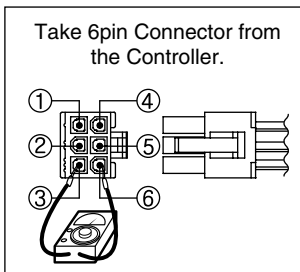

Check if resistance is in the range of Table 1 when measuring 6pin connector Pin ③ (Blue wire) and Pin ⑥ (Red wire) connected to Controller.

YES

- Check if Control and 6Pin connector is properly connected.
- Replace Controller.

NO

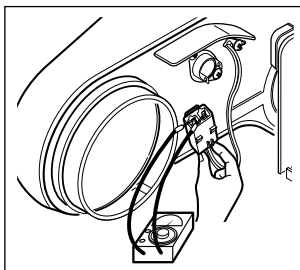

Check if resistance is in the range of Table 1 when measuring resistance between terminals after separating Harness From Thermistor assembly Connector.

NO

- Replace Thermistor.

YES

Check Harness-linking connector.

■ Table 1. Resistance for Thermistor Temperature.

| Air TEMP.[°F (°C)] | RES. [kΩ] | Air TEMP.[°F (°C)] | RES. [kΩ] | Air TEMP.[°F (°C)] | RES. [kΩ] |
|--------------------|-----------|--------------------|-----------|--------------------|-----------|
| 50°F (10°C) | 18.0 | 90°F (32°C) | 7.7 | 130°F (54°C) | 2.9 |
| 60°F (16°C) | 14.2 | 100°F (38°C) | 6.2 | 140°F (60°C) | 3.0 |
| 70°F (21°C) | 11.7 | 110°F (43°C) | 5.2 | 150°F (66°C) | 2.5 |
| 80°F (27°C) | 9.3 | 120°F (49°C) | 4.3 | 160°F (71°C) | 2.2 |

■ Test 3 Motor test

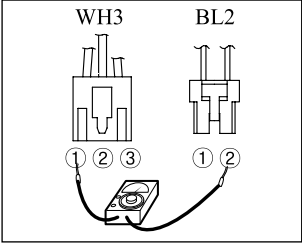
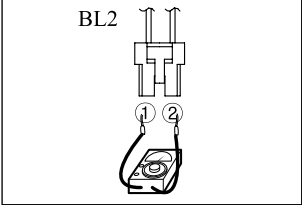
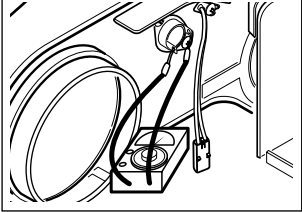
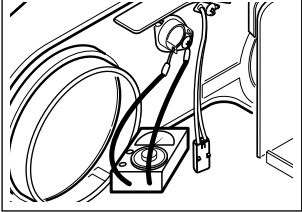
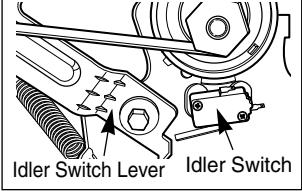
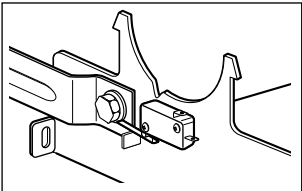
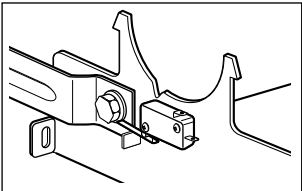
| | | |
|---|---|--|
| <p>Caution</p> | <p>Before measuring resistance, be sure to turn Power off, and do voltage discharge. (When discharging, contact the metal plug of Power cord with earth line.)</p> | |
| <p>Trouble Symptom</p> | <p>Drum will not rotate; No fan will function; No Heater will work.</p> | |
| <p>Measurement Condition</p> | <p>Turn the Dryer's Power Off, then measure resistance.</p> | |
|  | <p>Is resistance below 3Ω between Connector "WH3-①" (White wire) and "BL2-②" (Brown wire)? ※ Measure while door is closed.</p> <p>YES</p> | <ul style="list-style-type: none"> • Replace Control. (Relay check) • Check Controller connector. |
|  | <p>Is resistance below 3Ω between Connector "WH3-①" (White wire) and "BL2-①" (Yellow wire)? ※ Measure while door is closed.</p> <p>NO</p> | <ul style="list-style-type: none"> • Check if Door flame presses door switch knob. • Check Door Switch. • Check Harness connection. |
|  | <p>Is resistance below 3Ω between Connector "BL2-①" (Yellow wire) and "BL2-②" (Brown wire)?</p> <p>YES</p> | <ul style="list-style-type: none"> • Replace Control. (Relay check) • Check Controller connector. |
|  | <p>Is resistance below 1Ω between terminals of Outlet Thermostat attached to blower housing?</p> <p>NO</p> | <ul style="list-style-type: none"> • Replace Outlet • Thermostat. (Refer to 'Component') |
|  | <p>Does Idle Switch attached to Motor Bracket operate Level by drum belt? (Not operating Lever is normal.)</p> <p>YES</p> | <ul style="list-style-type: none"> • Check Idler Assembly. • Drum Belt cuts off • Drum Belt takes off from • Motor Pulley. |
|  | <p>Is resistance below 1Ω between Idler Switch terminals?</p> <p>NO</p> | <ul style="list-style-type: none"> • Replace Idler Switch. |
|  | <p>YES</p> <ul style="list-style-type: none"> • Check Motor. (Refer to 'Motor Diagram & Check') • Check if Control Connector is contacted. | |

■ Test 4 Moisture sensor

| | |
|------------------------------|---|
| Caution | Before measuring resistance, be sure to turn Power off, and do voltage discharge. (When discharging, contact the metal plug of Power cord with earth line.) |
| Trouble Symptom | Degree of dryness does not match with Dry Level. |
| Measurement Condition | Turn the Dryer's Power Off, then measure resistance. |

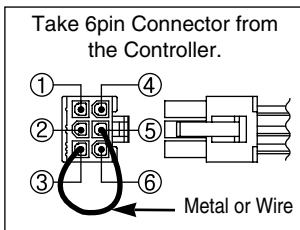

Short with metal to 6pin connector's Pin ③ (BLUE wire) and Pin ⑤ (ORANGE wire) to Controller.

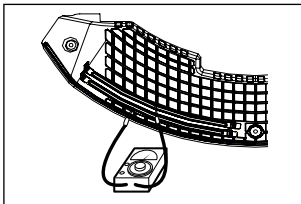

When measuring resistance in Electric load, is resistance below 1Ω ?

NO

- Check Electro Load and
- Harness Connector.
- Check Harness-linking connector.

YES

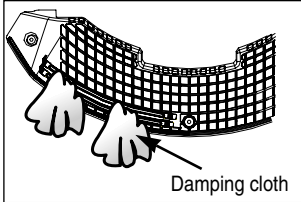

When contacting cloth to Electro load:
 1. Is the measurement within the range of Table 2 during Diagnostic Test?
 2. Is the measurement within the range of Table 2 when measuring the voltage in 6pin connector's Pin ③ (BLUE wire) and Pin ⑤ (ORANGE wire)?

NO

- Replace Control and Check.

YES

Normal Condition

■ Table 2. IMC Ratio and Display Value / Voltage (IMC : Initial Moisture Content)

| IMC | Display Value | Voltage(DC) (between 6Pin terminal ③,⑤) | Remark |
|---------------------|---------------|---|--|
| 70% ~ 40% | 50 ~ 130 | 2.5V | Weight after removing from Washing Machine |
| 40% ~ 20% | 100 ~ 20 | 2.0V ~ 4.0V | Damp Dry |
| 10% ~ Dried clothes | 205 ~ 240 | Over 4.0V | Completely-dried clothes |

■ Test 5 Door switch test

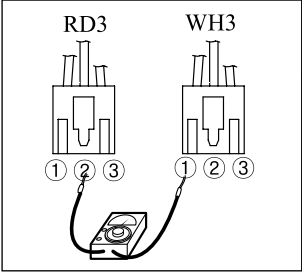
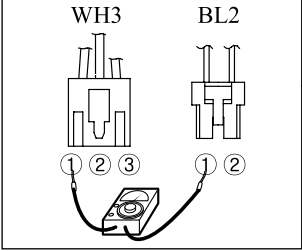
| | |
|--|---|
| Caution | Before measuring resistance, be sure to turn Power off, and do voltage discharge. (When discharging, contact the metal plug of Power cord with earth line.) |
| Trouble Symptom | Door Opening is not sensed.(During operation, when opening Door, Drum motor and Heater run continuously; Door Close is not sensed. (Drum motor will not operate. Display will flash at 0.5 second intervals.) |
| Measurement Condition | After turning Dryer Power Off, measure resistance. |
| <div style="display: flex; flex-direction: column; align-items: flex-start;"> <div style="display: flex; width: 100%; margin-bottom: 20px;"> <div style="width: 20%; text-align: center;">  </div> <div style="width: 60%; padding-left: 10px;"> <p>Measure while Door is closed. Check if resistance is below 250Ω between “WH3-①” (White wire) and “RD3-②”(Black wire) Connector WH3, RD3 after taking WH3, RD3 out from Controller.</p> </div> <div style="width: 15%; text-align: right; padding-right: 10px;"> <p>YES →</p> </div> <div style="width: 10%; text-align: center; margin: 0 10px;"> <p>NO ↓</p> </div> <div style="width: 60%; padding-left: 10px;"> <p>Measure while Door is open. Check if resistance is 300~60Ω between “WH3-①” (White wire) and “RD3-②” (Black wire) Connector WH3, RD3 after taking WH3, RD3 out from Controller.</p> </div> <div style="width: 15%; text-align: right; padding-right: 10px;"> <p>NO →</p> </div> <div style="width: 10%; text-align: center; margin: 0 10px;"> <p>YES ↓</p> </div> <div style="display: flex; width: 100%; margin-bottom: 20px;"> <div style="width: 20%; text-align: center;">  </div> <div style="width: 60%; padding-left: 10px;"> <p>Measure while Door is open. Check if resistance is below 1Ω between “BL2-①” (Yellow wire) and “WH3-①” (White wire) after taking Connector WH3, BL2 out from Controller.</p> </div> <div style="width: 15%; text-align: right; padding-right: 10px;"> <p>YES →</p> </div> <div style="width: 10%; text-align: center; margin: 0 10px;"> <p>NO ↓</p> </div> <div style="width: 60%; padding-left: 10px;"> <p>Measure while Door is closed. Check if resistance is below 1Ω between “BL2-①” (Yellow wire) and “WH3-①” (White wire) after taking Connector WH3, BL2 out from Controller.</p> </div> <div style="width: 15%; text-align: right; padding-right: 10px;"> <p>NO →</p> </div> <div style="width: 10%; text-align: center; margin: 0 10px;"> <p>YES ↓</p> </div> <div style="width: 60%; padding-left: 10px; border: 1px solid black; text-align: center;"> <p>Check Controller. Check Harness-linking connector.</p> </div> </div> <div style="display: flex; justify-content: space-between; margin-top: 20px;"> <div style="width: 45%; border: 1px solid black; padding: 5px;"> <ul style="list-style-type: none"> • Door switch Check (Refer to Component testing.) </div> <div style="width: 45%; border: 1px solid black; padding: 5px;"> <ul style="list-style-type: none"> • Check Lamp. (When opening Lamp, replace then measure again.) • Door switch Check(Refer to Component testing.) </div> </div> <div style="display: flex; justify-content: space-between; margin-top: 20px;"> <div style="width: 45%; border: 1px solid black; padding: 5px;"> <ul style="list-style-type: none"> • Door switch Check (Refer to Component testing.) </div> <div style="width: 45%; border: 1px solid black; padding: 5px;"> <ul style="list-style-type: none"> • Door switch Check (Refer to Component testing.) </div> </div> </div> </div> | |

■ Test 6 Heater switch test - Electric Type

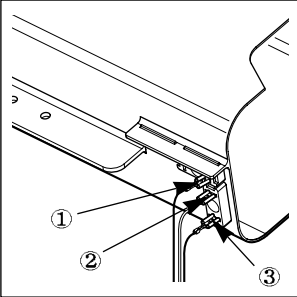
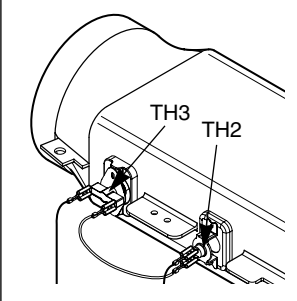
| | | |
|--|---|---|
| Caution | Before measuring resistance, be sure to turn Power off, and do voltage discharge. (When discharging, contact the metal plug of Power cord with earth line.) | |
| Trouble Symptom | While operating, Heating will not work. Drying time takes longer. | |
| Measurement Condition | After turning Power off, measure the resistance. | |
|  | <ol style="list-style-type: none"> 1. Is resistance between Heater terminal ① and ② below 18 ~ 22Ω? 2. Is resistance between Heater terminal ① and ③ below 18 ~ 22Ω? 3. Is resistance between Heater terminal ② and ③ below 9 ~ 11Ω? | <p>NO</p> <ul style="list-style-type: none"> • Replace Heater. |
| YES | | |
|  | <p>Check if the value of measured resistance is below 1Ω between terminal TH2 (Safety Thermostat).</p> | <p>NO</p> <ul style="list-style-type: none"> • Replace TH2 (Safety Thermostat). |
| YES | | |
| <p>Check if the value of measured resistance is below 1Ω between terminal TH3 (HI-Limit Thermostat).</p> | | <p>NO</p> <ul style="list-style-type: none"> • Replace TH3 (HI-Limit Thermostat). |
| YES | | |
| <p>Check Motor. Check if the value of measured resistance is below 1Ω between terminal ① and ⑩ at RUN condition.</p> | | <p>NO</p> <ul style="list-style-type: none"> • Check Motor and replace it. |
| YES | | |
| <p>Check Controller. Check Harness-linking Connector.</p> | | |

■ Test 7 GAS Valve test - Gas Type

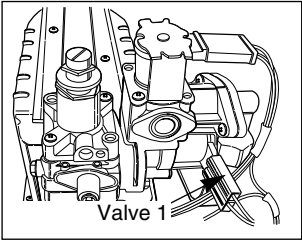
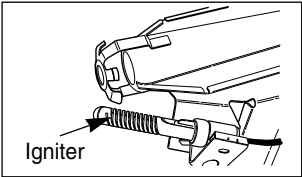
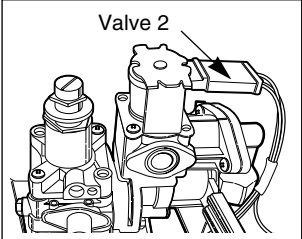
| | |
|--|--|
| Caution | When measuring power, be sure to wear insulated gloves, to avoid electric shock. |
| Trouble Symptom | While operating, Heating will not work. Drying time takes longer. |
| Measurement Condition | With dryer power on |
| <div style="display: flex; justify-content: space-between; align-items: flex-start;"> <div style="width: 25%;">  <p>Valve 1</p> </div> <div style="width: 70%;"> <p>Power On & Start (Normal Cycle)</p> <p style="text-align: center;">NO</p> <p>When measuring Valve 1 voltage, More than AC 90V?</p> <p style="text-align: right;">NO</p> <ul style="list-style-type: none"> • Check thermostat • Hi limit Safety <p style="text-align: center;">YES</p> <p>Igniter operates? (after 1 min, Igniter becomes reddish)</p> <p style="text-align: right;">NO</p> <ul style="list-style-type: none"> • Check Igniter & Frame detect <p style="text-align: center;">YES</p> <p>When measuring Valve 2 voltage, Value is more than AC 90V? (10 sec after Igniter off)</p> <p style="text-align: right;">YES</p> <ul style="list-style-type: none"> • Check Gas connection or Gas supply <p style="text-align: center;">NO</p> <p>When measuring terminal resistance on "Valve 1", "Valve 2", Value is more than 1.5 ~ 2.5kΩ? (Measure after Off)</p> <p style="text-align: right;">YES</p> <ul style="list-style-type: none"> • Change Valve <p style="text-align: center;">NO</p> <ul style="list-style-type: none"> • Harness check • Controller change </div> </div> <div style="width: 25%; margin-top: 20px;">  <p>Igniter</p> </div> <div style="width: 25%; margin-top: 20px;">  <p>Valve 2</p> </div> | |

Warning

After Natural Gas Setting, applying Propane Gas Orifice or wrong use of Natural Gas Orifice will result in fire. Conversion must be made by a qualified technician.

Initially, Natural Gas mode is set. Propane Gas Orifice is on sale as a Service Part to authorized servicers only.

STEP 1 : VALVE SETTING

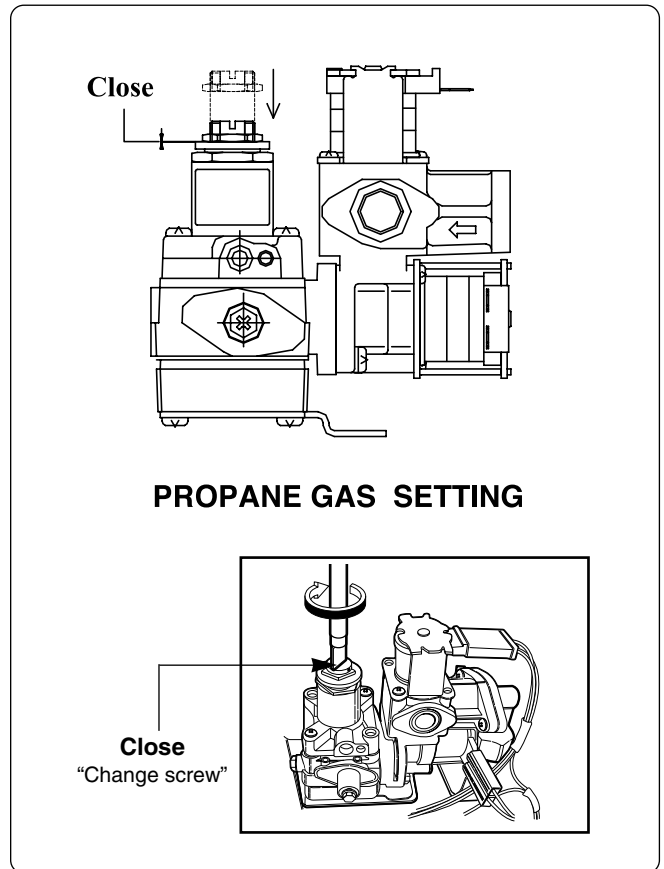
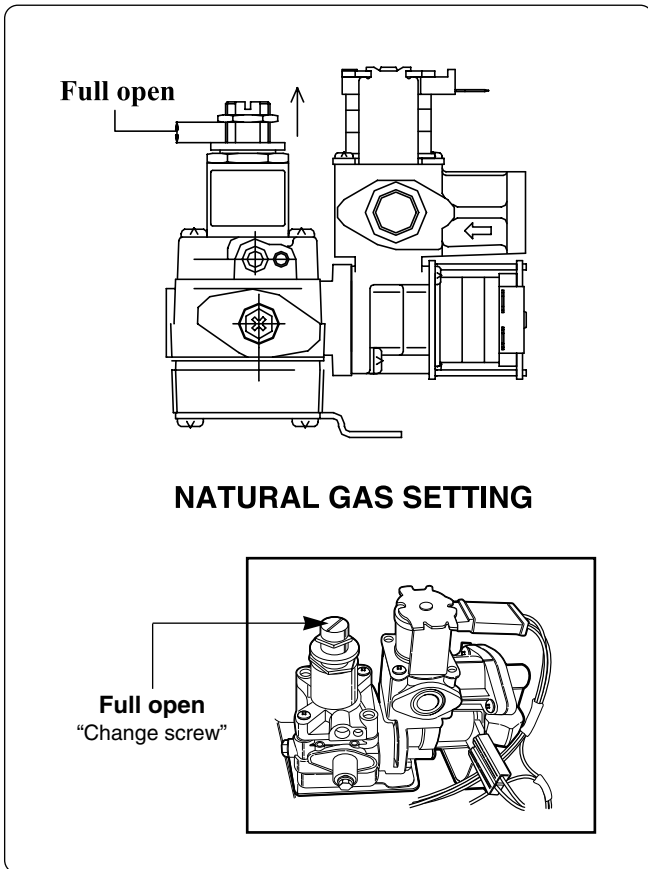

STEP 2 : ORIFICE CHANGE

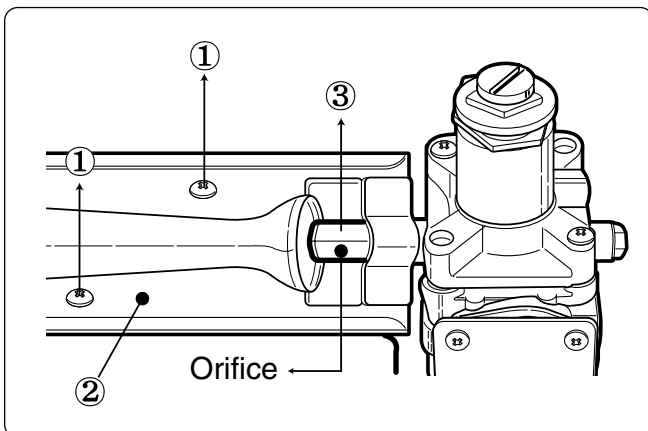

- ① Remove 2 screws.
- ② Disassemble the pipe assembly.
- ③ Replace Natural Gas orifice with Propane Gas orifice.

| Gas type | Orifice P/No | Marking | Shape |
|-------------|--------------|---------|-------|
| Natural Gas | 4948EL4001B | NCU | |
| Propane Gas | 4948EL4002B | PCU | |

※ **Kit contents** : Orifice (Dia. = 1.613mm, for Propane Gas)
 : Replace Label
 : Instruction sheet

■ GAS VALVE FLOW

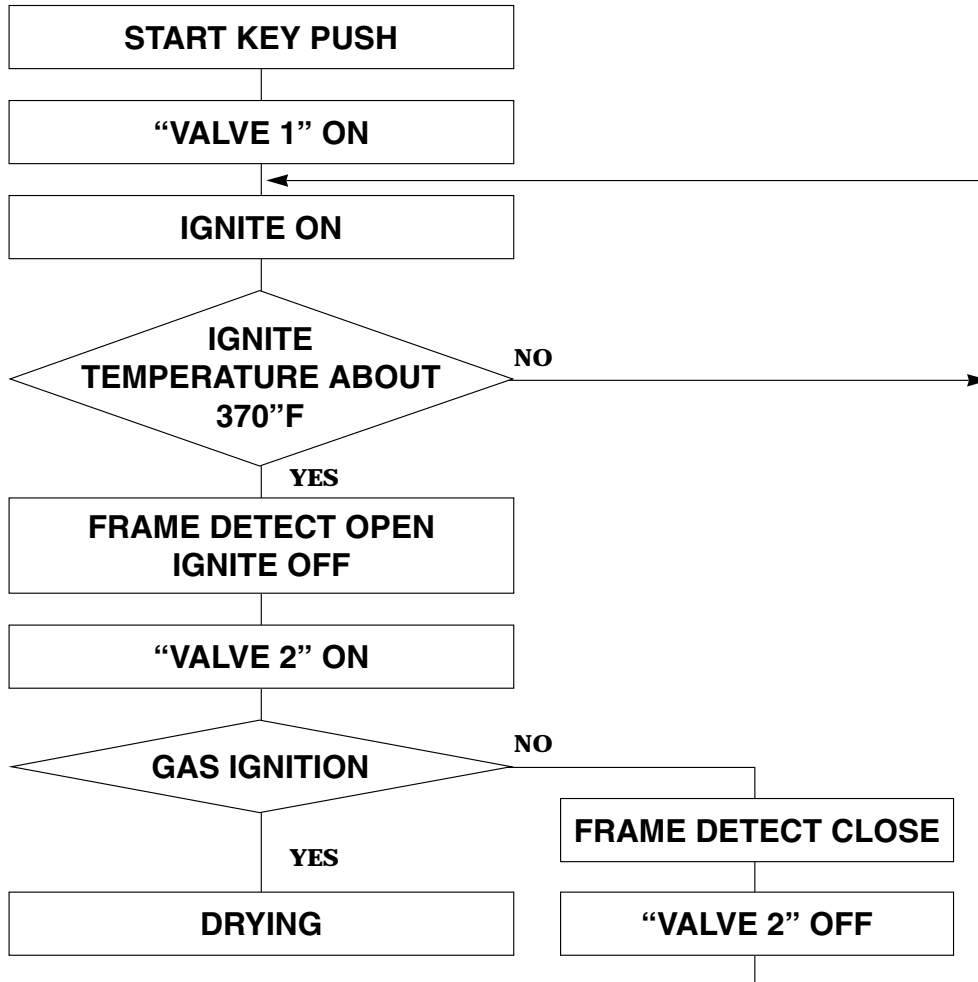

GAS IGNITION

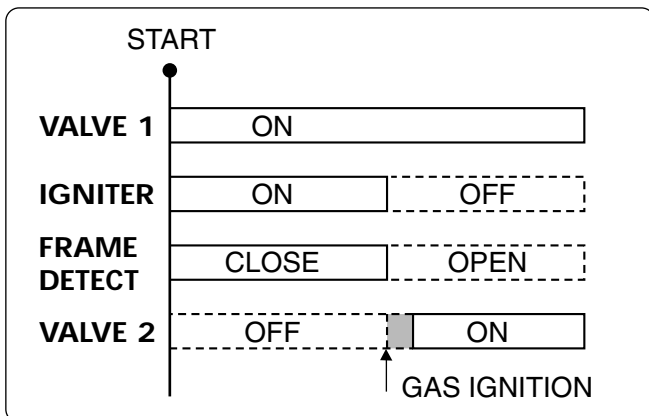

GAS VALVE STRUCTURE

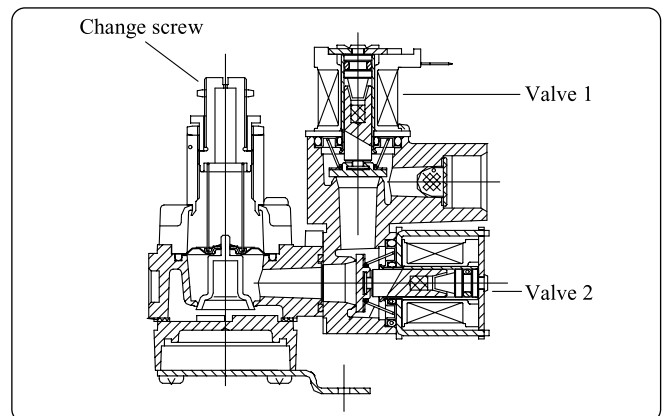

11

DISASSEMBLY INSTRUCTIONS

* Disassemble and repair the unit only after pulling out power plug from the outlet.

TOP PLATE

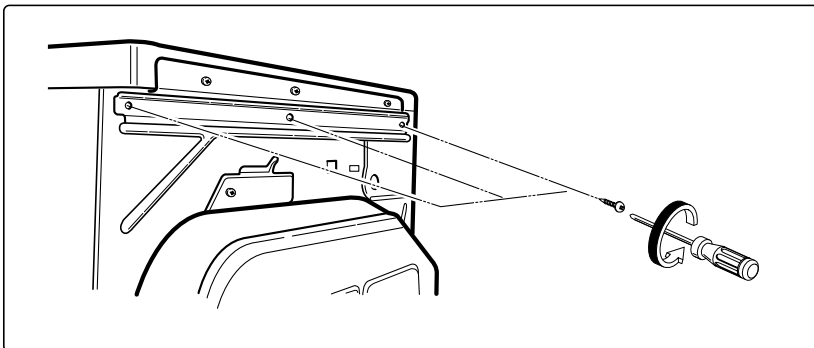

1. Remove 3 screws on the upper plate.

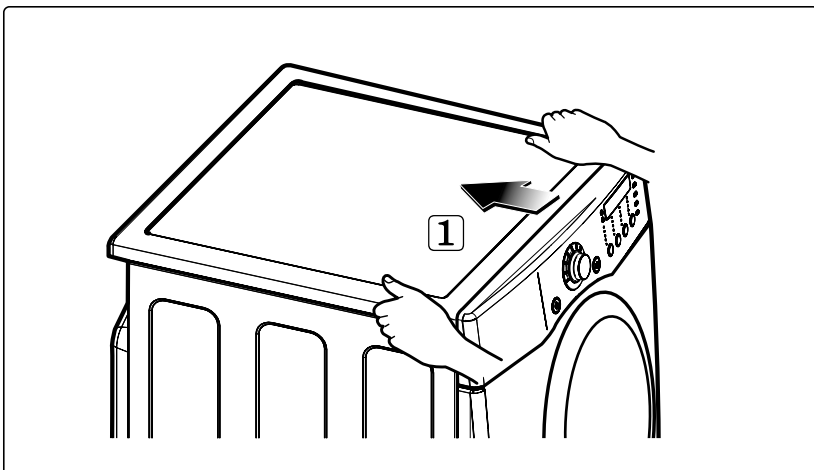

2. Push the top plate back ward.

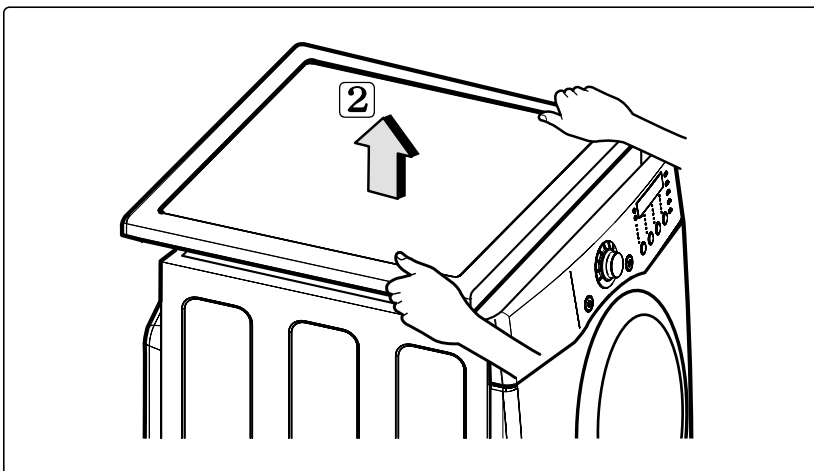

3. Lift the top plate

CONTROL PANEL ASSEMBLY

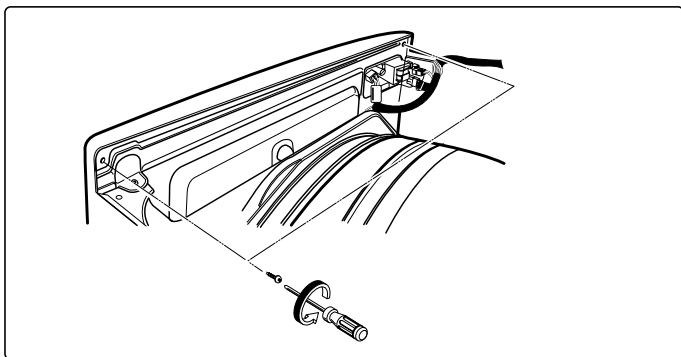

1. Remove 2 screws on the control panel frame.

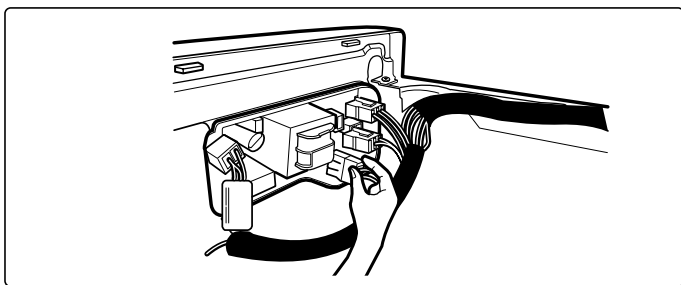

2. Disconnect the connectors.

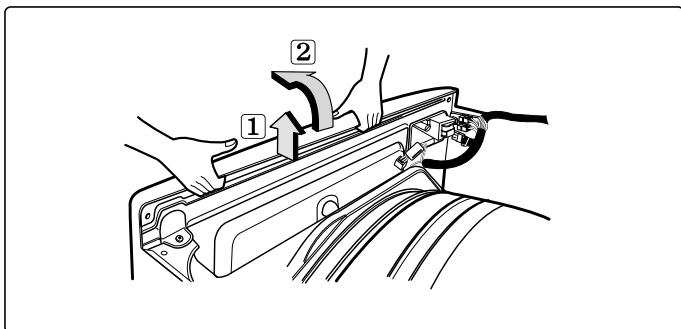

3. Pull the control panel assembly upward and then forward.

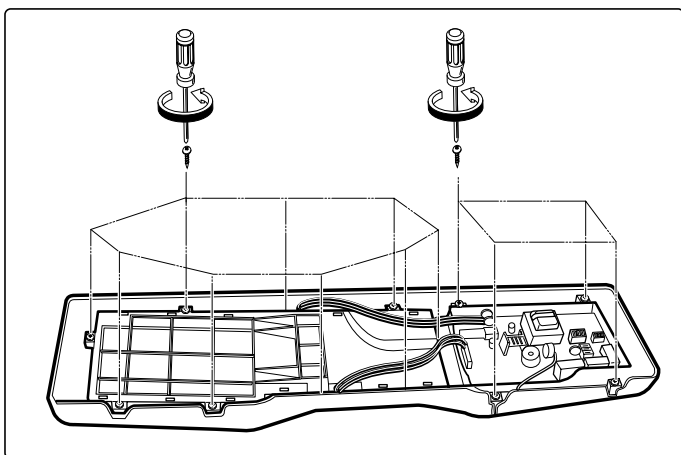

4. Remove 9 screws on the PWB(PCB) assembly, display.
5. Remove 4 screws on the PWB(PCB) assembly, main.
6. Disassemble the control panel assembly.

COVER CABINET

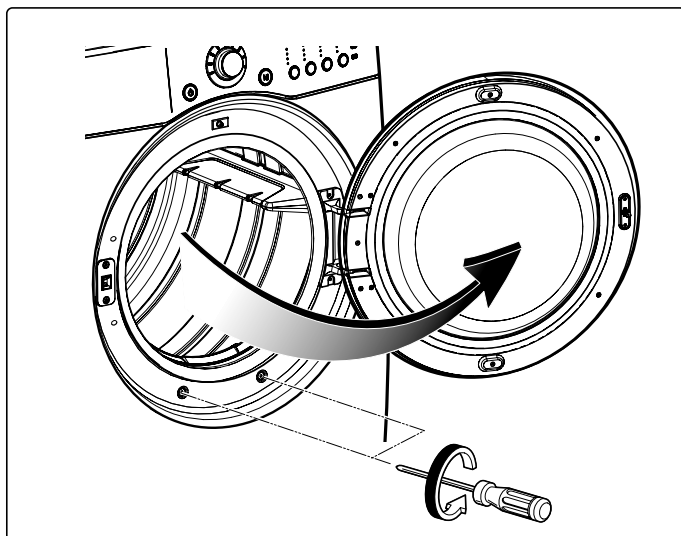

1. Disassemble the top plate.
2. Disassemble the control panel assembly.
3. Disassemble the door assembly.
4. Remove 2 screws.

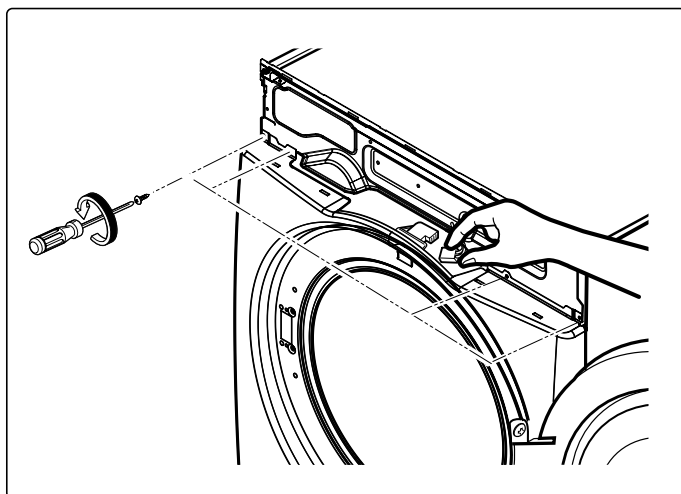

5. Remove 4 screws from the top of cabinet cover.
6. Disconnect the harness of door switch.

TUB DRUM [FRONT]

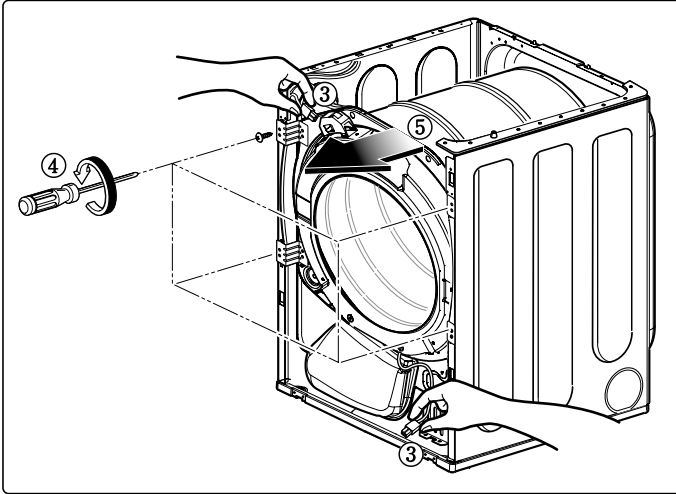

1. Disassemble the top plate.
2. Remove Cover Cabinet.
3. Disconnect the door lamp and electrode sensor connector.
4. Remove 4 screws.
5. Disassemble the Tub Drum [Front].

DRUM ASSEMBLY

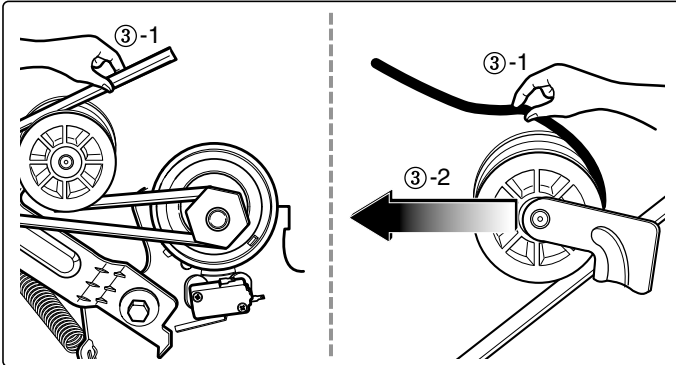

1. Disassemble the top plate.
2. Remove the Cabinet Cover and Tub drum [front].
3. Loosen belt from motor and idler pulleys.
4. Carefully remove Drum out.

CHANGING THE DRUM LAMP

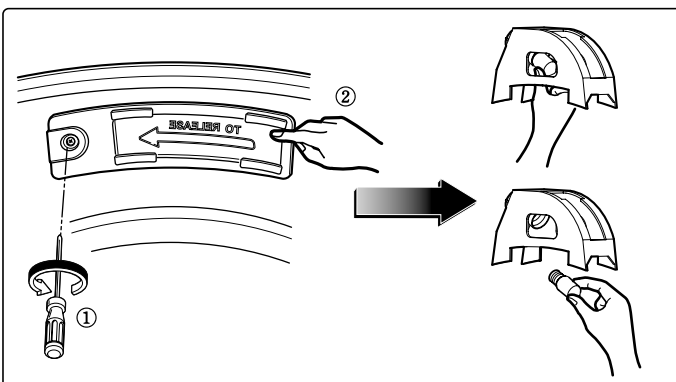

1. Disassemble the door.
2. Remove a screw by holding the drum lamp shield in place.
3. Slide the shield up and remove.
4. Remove the bulb and replace with a 15 watt, 120 volt candelabra-base bulb.
5. Replace the lamp shield and screw.

DRYER EXHAUST CHANGE

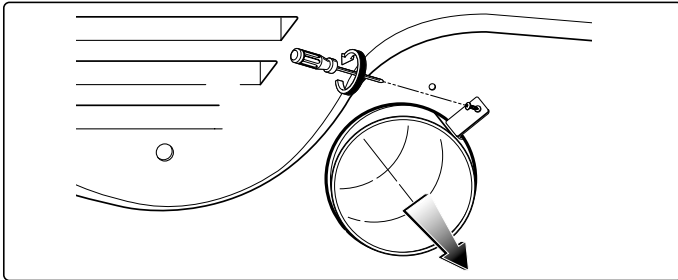

1. Remove a screw and exhaust duct.

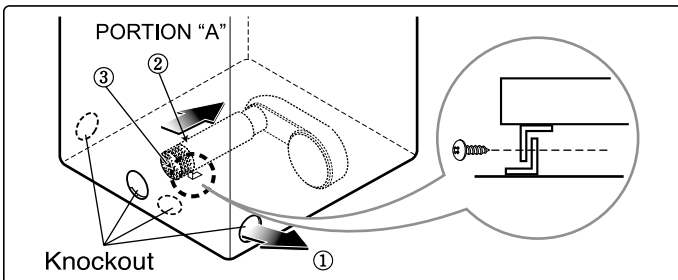

2-1. Detach and remove a knockout at the bottom, left or right side as desired. (Right Side Vent not available on Gas dryer)
①, ②, ③ the order of work.

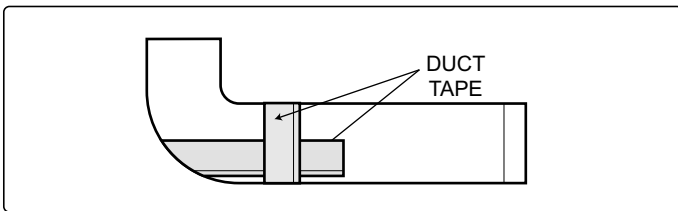

2-2. Reconnect the another duct[11 in(28cm)] to the blower housing, and attach the duct to the base. (Duct is a SVC part)

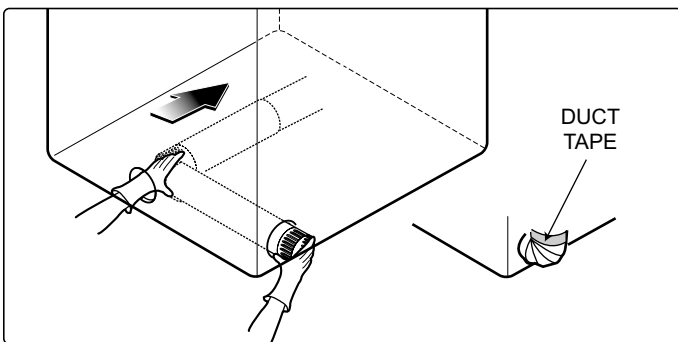

3-1. Pre-assemble 4" elbow with 4" duct.
Wrap duct tape around joint.

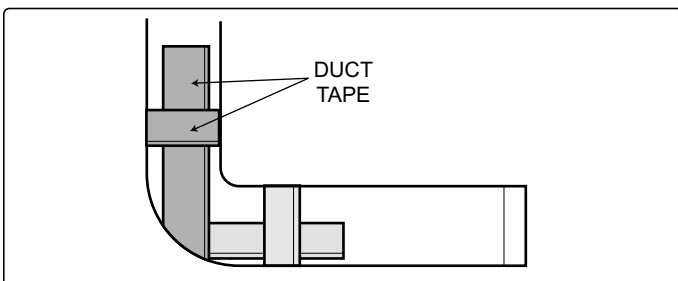

3-2. Insert elbow duct assembly first through the side opening and connect the elbow to the internal duct.

FILTER ASSEMBLY

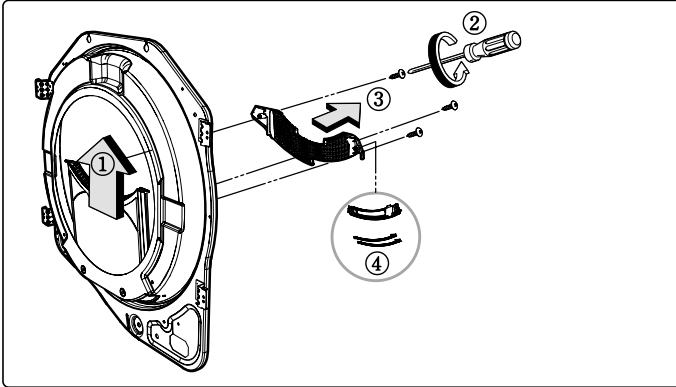

1. Remove the filter.
2. Remove 3 screws.
3. Remove Cover Grille.
4. Disconnect electrode sensor.

BLOWER HOUSING

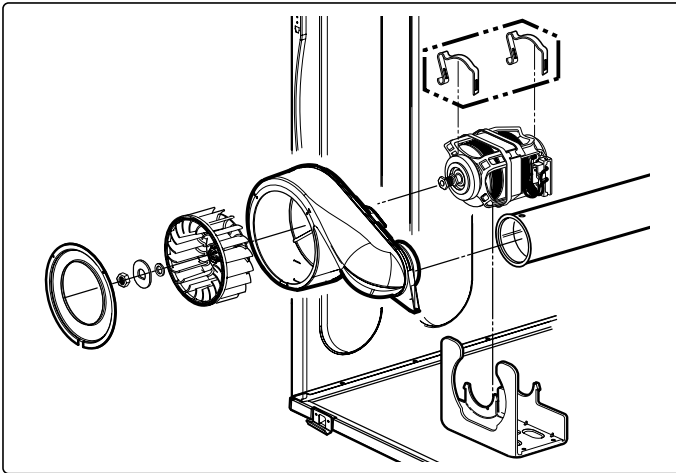

1. Disassembly the top plate.
2. Remove the Cabinet Cover and Tub Drum [Front].
3. Remove the Drum assembly.
4. Remove 2 screws and cover(Air guide).
5. Remove the bolt and washer.
6. Remove the fan.
7. Disconnect the motor clamp and motor.

BACK COVER

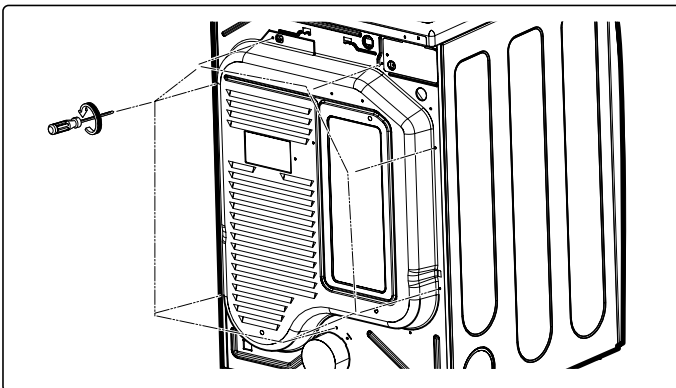

1. Disassemble the top plate.
2. Remove the Cabinet Cover and Tub Drum [Front].
3. Remove the Drum assembly.
4. Remove 7 screws.
5. Remove the Tub Drum [Rear] towards the front.

AIR DUCT

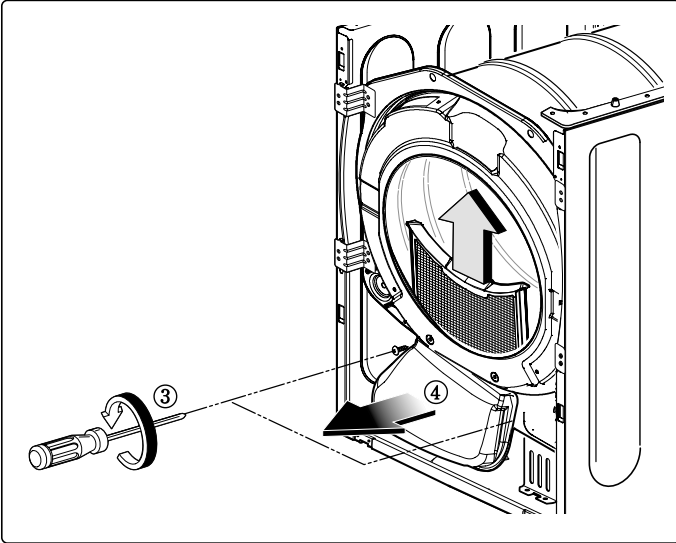

1. Disassemble the top plate.
2. Remove the Cover Cabinet.
3. Remove filter and 2 screws.
4. Remove the air duct.

ROLLERS

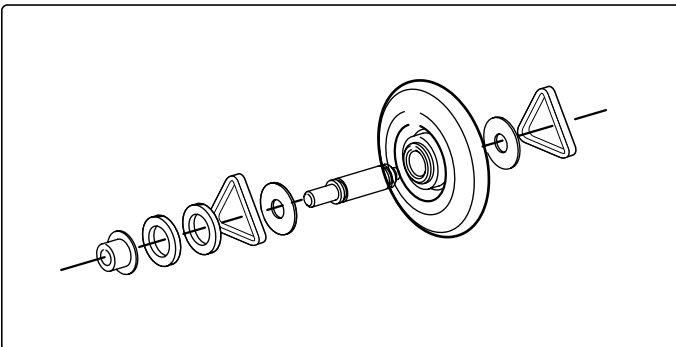

1. Disassemble the top plate.
2. Remove the Cover Cabinet and Tub Drum [Front].
3. Remove the Drum assembly and Tub Drum [Rear].
4. Disconnect Air duct from the Tub Drum [Front].
5. Remove the roller from the Tub Drum [Front] and Tub Drum [Rear].

12

EXPLODED VIEW

12-1. Control Panel & Plate Assembly

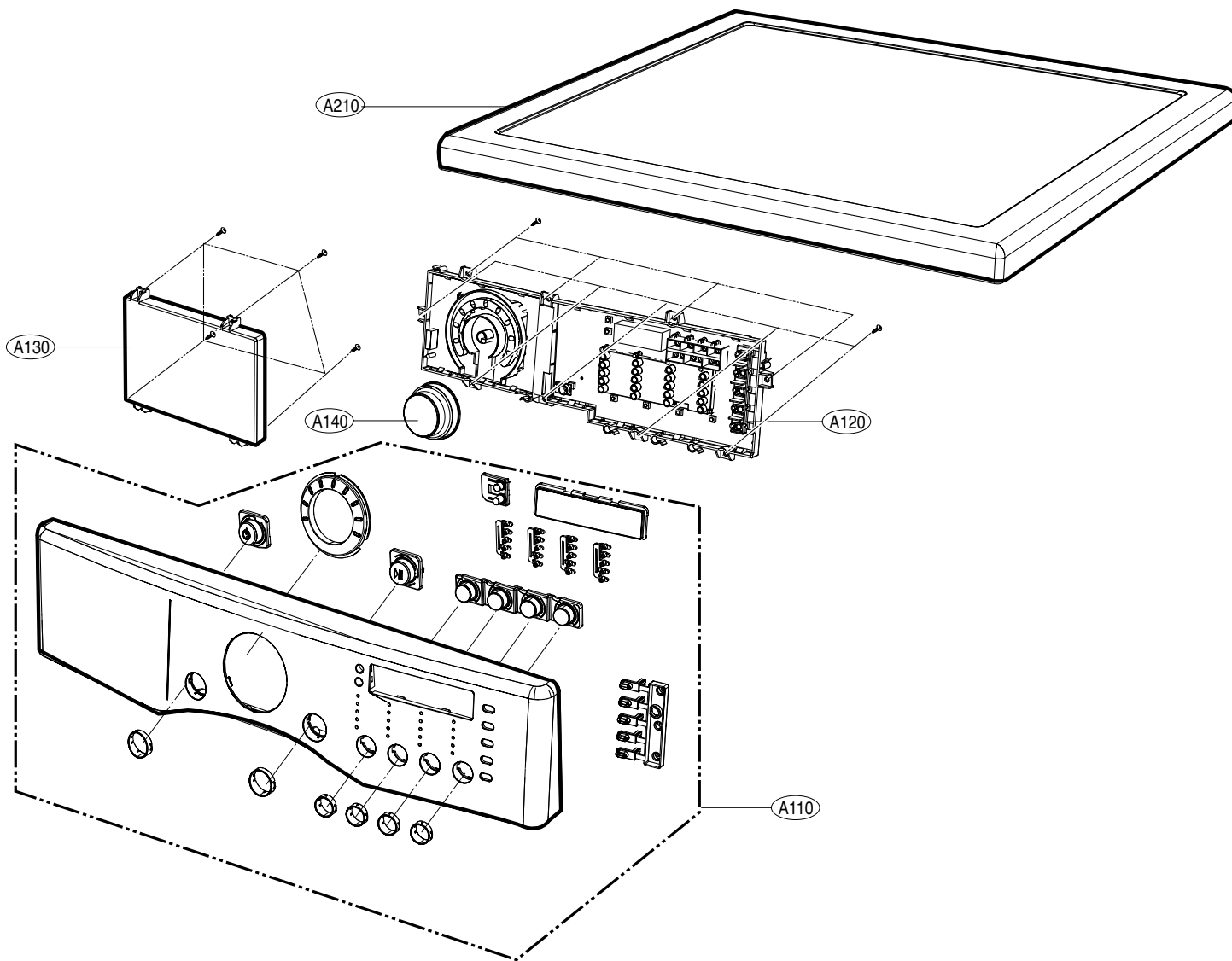

12-2. Cabinet & Door Assembly

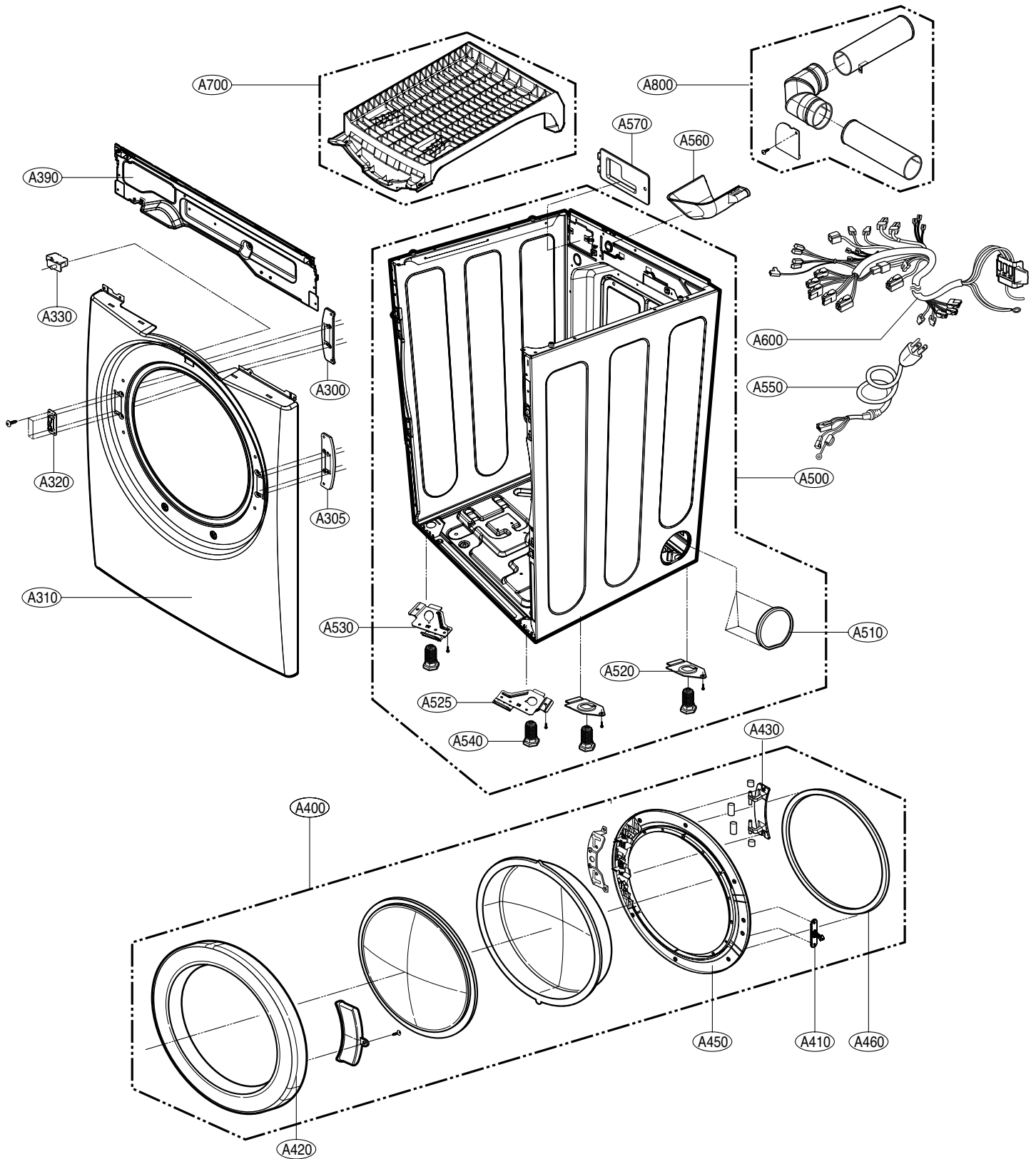

12-3-1. Drum & Motor Assembly : Electric Type

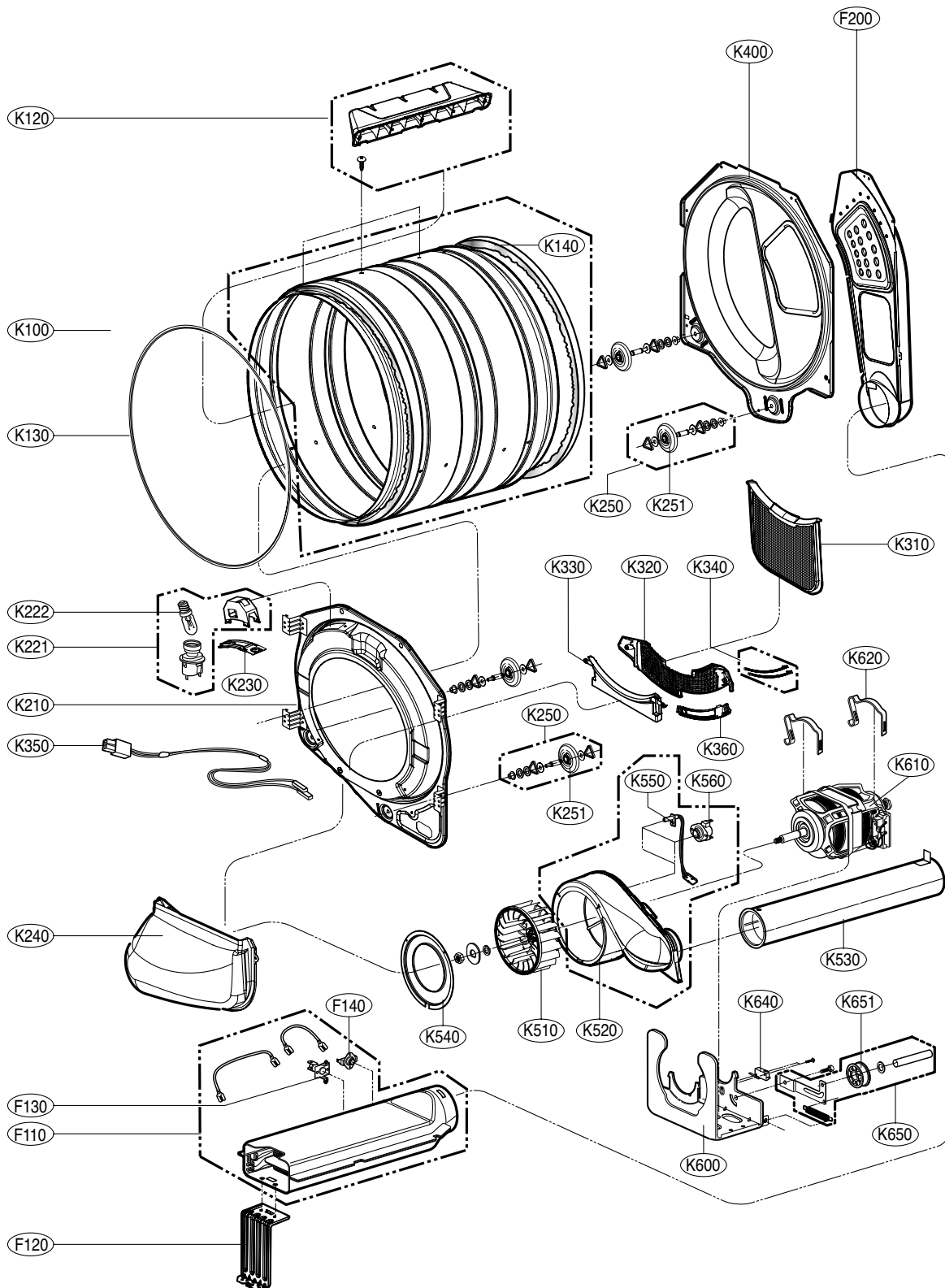

12-3-2. Drum & Motor Assembly : Gas type

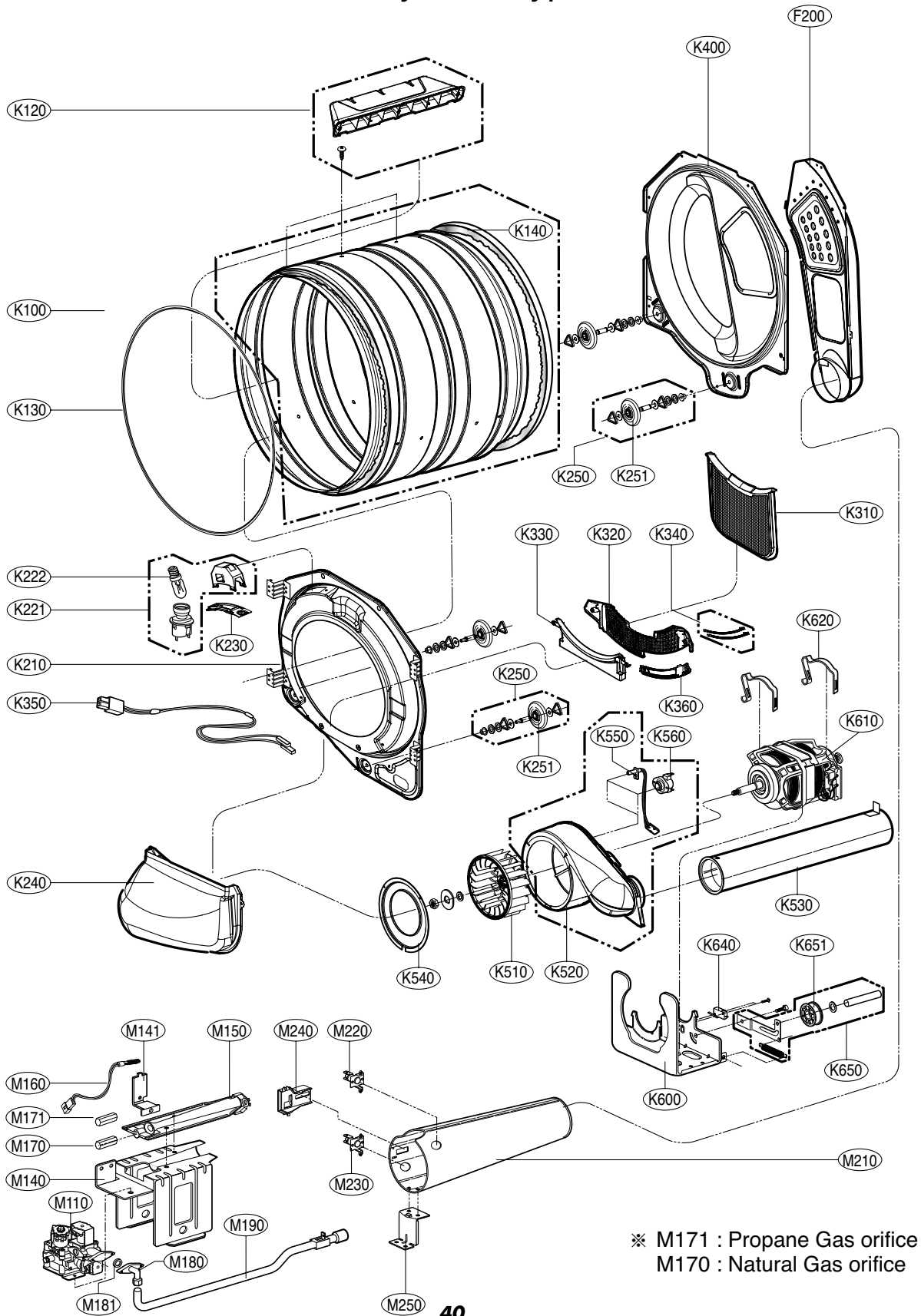

※ M171 : Propane Gas orifice
M170 : Natural Gas orifice