

MAYTAG

**Maytag
1999
Sloped-Front**

**Dryer
Service Manual**

16023110

SAFETY PRECAUTIONS

This manual, as well as the information contained in it, is to be used only by a Maytag Authorized Service Technician familiar with and knowledgeable of proper safety and servicing procedures and possessing high quality testing equipment associated with microwaves, gas, and electrical appliance repair.

All individuals who attempt repairs by improper means or adjustment subject themselves and others to the risk of serious or fatal injury.

USE ONLY GENUINE MAYTAG APPROVED FACTORY REPLACEMENT COMPONENTS.

INTRODUCTION

Each model will be covered separately in a section pertaining only to its control system and internal components. Because the basic structure for all dryers is the same, they will be generally covered without regard to model.

Models covered in this manual:

MDG9800	MDE3000	MDG3000
MDE9800	MDE4000	MDG4000
MDE6800	MDE5000	MDG5500
MDG6800	MDE5500	MDG6000
MDE7000	MDE6000	MDG6200
MDE7600	MDE6200	MDG7057
MDG7600	MDE7057	MDG7500
MDE8600	MDE7500	MDG8000
MDG8600	MDE8000	
	MDE8500	

Model Number Breakdown:

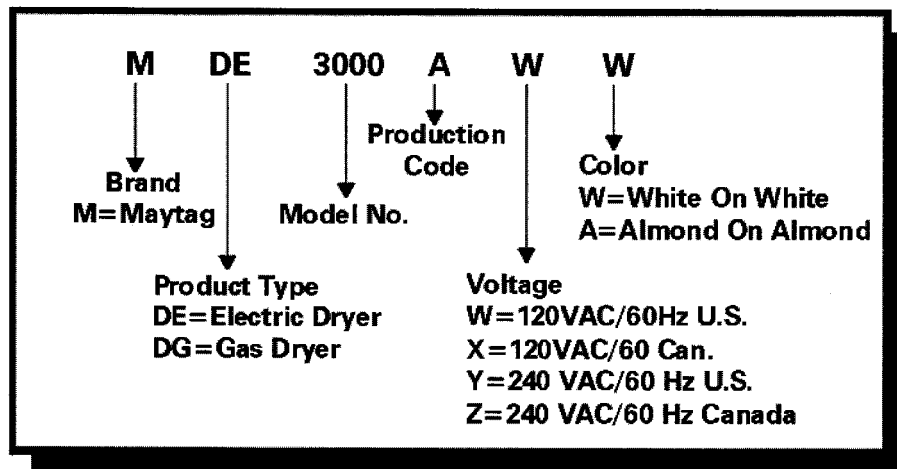

For additional information on issues encompassed in this manual, including safety issues, contact:

Maytag Appliances Sales Company
240 Edwards Street, S.E.
Cleveland, TN 37311

Phone: 423-472-3333
Fax: 423-478-6722

NOTES

CONTENTS

SECTION 1 - GENERAL INFORMATION	1-1
PRE-INSTALLATION CONSIDERATIONS	1-1
Check Points For Proper Installation	1-1
Location Considerations.....	1-1
Alcove or Closet Installation	1-1
Manufactured Home Installation.....	1-2
INSTALLATION	1-2
Ducting	1-2
Gas Requirements.....	1-3
Electrical Requirements.....	1-4
GROUNDING POLARITY CHECKS	1-4
SPECIFICATIONS	1-5
General Component Exploded View	1-6
CONTROL FACIA (MDE/DG5500, MDE/DG7500)	1-7
PRODUCT SPECIFICATIONS	1-7
SECTION 2 - ELECTRICAL COMPONENTS & TESTING	2-1
TEST EQUIPMENT	2-1
Analog Test Meter	2-1
Clamp-On Ammeter	2-1
Digital Test Meter	2-1
AC Voltage Sensor	2-1
Air Test Meter	2-1
Water Column Manometer.....	2-1
Manometer	2-2
ELECTRICAL TESTS	2-3
Voltage Checks	2-3
Door Switch.....	2-3
Timer & Console Switches.....	2-4
Drive Motor Check	2-4
Motor Test Cord.....	2-5
Centrifugal Start Switch	2-5
ELECTRICAL TESTS LCD/LED DRYERS	2-6
Input/Output Voltages	2-7
Membrane Pad Checks	2-8
SECTION 3 - TROUBLESHOOTING GUIDE	3-1
FUNDAMENTAL CHECKS	3-1
Will Not Run	3-1
Will Not Dry	3-1
Will Not Shut-Off	3-2
Noisy and/or Vibration	3-2
DIRECT IGNITION SYSTEM	3-2

SECTION 4 - CONSOLE ASSEMBLY	4-1
REMOVAL	4-1
VERTICAL SWITCHES	4-2
HORIZONTAL SWITCHES	4-2
TIMER REMOVAL	4-2
CONSOLE W/MEMBRANE PAD (MDE/DG5500, and 7500)	4-3
SECTION 5 - CABINET ASSEMBLY COMPONENTS	5-1
DOOR ASSEMBLY & HINGES	5-1
FRONT PANEL	5-1
TOP COVER	5-2
SECTION 6 - TUMBLER & BULKHEADS	6-1
SHROUD & TUMBLER FRONT ASSEMBLY	6-1
LINT FILTER	6-2
BEARING & PADS	6-2
TUMBLER FRONT SEAL	6-3
TUMBLER & BELT	6-3
BAFFLES	6-4
TUMBLER BACK ASSEMBLY	6-5
TUMBLER BACK SEAL	6-5
ROLLER & BEARING ASSEMBLY	6-6
SECTION 7 - BLOWER & MOTOR DRIVE SYSTEM	7-1
CYCLING THERMOSTATS	7-1
HI-LIMIT THERMOSTAT	7-1
THERMAL FUSES	7-1
BLOWER ASSEMBLY	7-2
Seal for Blower	7-2
Cover for Blower	7-2
Blower Wheel	7-3
Exhaust Duct Pipe	7-3
DRIVE MOTOR & IDLER ASSEMBLY	7-3
Motor Switch	7-3
Blower & Motor Assembly	7-4
Idler Arm Assembly	7-4
SECTION 8 - HEATING COMPONENTS	8-1
GAS VALVE ASSEMBLY	8-1
Igniter	8-1
Radiant Sensor	8-1
Gas Valve	8-1
Function of Gas Valve System	8-2
Gas Conversions	8-3
Safety Features	8-3
Air Shutter Adjustment	8-4
Gas Valve Removal	8-5
Inlet Duct	8-5
HEATING ELEMENT & RELATED COMPONENTS	8-6

SECTION 9 - DRYER CONTROLS OVERVIEW	9-1
DRYER CONTROLS OVERVIEW	9-1
BASIC CONTROL BOARD PHILOSOPHY FOR BOTH DRYERS	9-1
BASIC MACHINE OPERATION	9-2
LED DRYER CONTROL SELECTIONS	9-3
DRYER TEMPERATURE CONTROL	9-5
SPECIAL FEATURES	9-6
SERVICE/DIAGNOSTIC MODE	9-6
LED DRYER	9-7
LCD DRYER	9-9
SYSTEM CHECK	9-10
DIAGNOSTIC/HELP CODES	9-10
CONTROL CONFIGURATION MDE/MDG6800, MDG5500	9-12
SERVICE MODE MDE/MDG6800, MDG5500	9-12
MEMBRANE PAD CHECK MDE/MDG6800, MDG5500	9-12
SYSTEM CHECK MODE MDE/MDG6800, MDG5500	9-12
DIAGNOSTIC CODES MDE/MDG6800, MDG5500	9-13
MEMBRANE PAD CONTINUITY CHECKS MDE/MDG6800, MDG5500	9-14
SERVICE MODE MDE/MDG7500, MDE/MDG9800	9-15
USER INTERFACE MDE/MDG7500, MDE/MDG9800	9-16
MEMBRANE PAD CHECK MDE/MDG7500, MDE/MDG9800	9-16
SYSTEM CHECK MDE/MDG7500, MDE/MDG9800	9-16
DIAGNOSTIC/HELP CODES MDE/MDG7500, MDE/MDG9800	9-16
MEMBRANE PAD CONTINUITY CHECKS MDE/MDG7500, MDE/MDG9800	9-17
SECTION 10 - ELECTRICAL SCHEMATICS	10-1
MDE3000	10-1
MDG3000	10-2
MDE4000AZ, MDE8000AZ	10-3
MDE5000AZ	10-4
MDG7057	10-5
MDG6000, MDG7000	10-6
MDE6000AZ, MDE7000AZ	10-7
MDE4000AY, MDE8000AY	10-8
MDE6000AU/AY, MDE7000AY	10-9
MDE7057AY	10-10
MDG4000AW/AX/BW, MDG8000AW/BW	10-11
MDE5500	10-12
MDE5500 (Canada)	10-13
MDG5500	10-14
MDE7500	10-15
MDE7500 (Canada)	10-16
MDG7500	10-17
MDG6200	10-18
MDE7600	10-19
MDG7600	10-20
MDE7600 (Canada)	10-21
MDE8600	10-22
MDE8600 (Canada)	10-23
MDG8600	10-24
MDE6200	10-25

MDE6200 (Canada)	10-26
MDE6800	10-27
MDG6800	10-28
MDE9800	10-29
MDG9800	10-30

SECTION 1 - GENERAL INFORMATION

PRE-INSTALLATION CONSIDERATIONS

NOTE: *Proper installation is the responsibility of the purchaser.*

Checkpoints for proper installation

- **Gas Dryers** - Properly grounded electrical outlet is required. Use a 15 amp fuse or comparable circuit breaker for electrical service for gas dryers. **DO NOT USE AN EXTENSION CORD** unless the cord has met all requirements for proper grounding, polarizing (3 wire) and at least 14 gauge wire.

1/2" gas supply line is recommended and must be reduced to connect to the 3/8" gas line of the dryer.

The National Fuel Gas Code requires an acceptable, approved manual shut off valve to be installed within six feet of the dryer.

- **Electric Dryers** - Properly grounded electrical outlet is required. Use a 30 amp fuse or comparable circuit breaker for electrical service for an electric dryer.

Location Considerations

The dryer should be located to permit 18" in front for removal of the front panel for access, and sufficient room behind the dryer for the exhaust system.

The dryer is factory-ready for rear exhaust. Exhausting out the bottom or left side requires accessory vent kit, **part number 12001453**.

It is important to make sure the room has adequate makeup air. The area where the dryer is located must not obstruct the flow of combustion or ventilating air.

On gas dryers, adequate clearance as noted on the data plate must be maintained to ensure adequate air for combustion and proper operation of the dryer.

THE DRYER MUST NOT BE INSTALLED OR STORED IN AN AREA WHERE IT WILL BE EXPOSED TO WATER AND/OR WEATHER. THE DRYER IS TO BE KEPT CLEAR AND FREE FROM COMBUSTIBLE MATERIALS, GASOLINE AND OTHER FLAMMABLE VAPORS AND LIQUIDS. A DRYER PRODUCES COMBUSTIBLE LINT. THE AREA AROUND THE DRYER SHOULD BE KEPT FREE OF LINT.

Alcove or Closet Installation



Warning - Always shut off electrical power to the dryer before beginning any service repair procedures.

An appliance installed in a closet shall not have another fuel-burning appliance installed in the same closet.

Each opening area in the door must have a minimum of 36 square inches. These openings must not be obstructed. (Louvered door with equivalent air opening is acceptable.)

Manufactured Home Installation

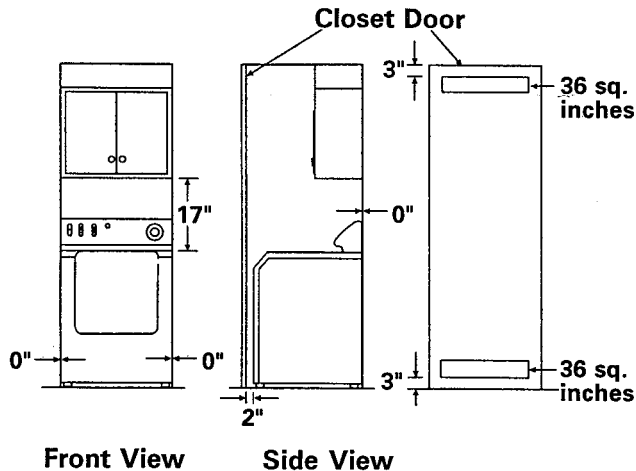

Figure 1-1

The installation of the dryer in manufactured homes must conform to the Manufactured Home Construction and Safety Standard Title 24 CFR, Part 32-80 (formerly the Federal Standard for Mobile Home Construction and Safety, Title 24, HUD (Part 280), 1975) for the United States, or C.S.A. Standards Z240 (for Canada).

All manufactured home installations must be exhausted to the outside with the exhaust duct termination securely fastened to the manufactured home structure, using materials that will not support combustion. The exhaust duct may not terminate beneath the manufactured home. (See DUCTING)

INSTALLATION

Ducting

DO NOT EXHAUST DRYER INTO ANY WALL, CEILING, CRAWL SPACE OR CONCEALED SPACE OF A BUILDING, VENT CONNECTION, GAS VENT OR CHIMNEY. THIS COULD CREATE A FIRE HAZARD FROM LINT EXPELLED BY THE DRYER. FOR THE SAME REASON, WE RECOMMEND ONLY METAL EXHAUST DUCT TO MINIMIZE RESTRICTED AIR FLOW AND RELIABLY ENSURE THE CONTAINMENT OF EXHAUST AIR, HEAT AND LINT. NEVER INSTALL A SCREEN OR

OTHER COMBUSTIBLE DUCTWORK. AT LEAST ONCE A YEAR, INSPECT AND CLEAN INTERIOR OF DUCTWORK. FREQUENTLY CHECK AND CLEAN VENT HOOD TO ENSURE PROPER OPERATION.

A clothes dryer produces combustible lint. The area around the clothes dryer should be kept free of lint. It is recommended that the dryer be exhausted to the outside using 4" rigid or flexible metal ducting.

Plastic flexible duct can kink, sag, be punctured, reduce airflow, extend drying times, and affect dryer operation.

If flexible metal duct must be used, use the type with a stiff sheet metal wall. Do not use flexible duct with a thin foil wall. Serious blockage can result if flexible metal duct is bent too sharply. Never install any type of flexible duct in walls, ceilings, or other concealed spaces.

Once location of the exhaust outlet is determined, a 4 1/4" hole should be cut into the outside wall to accept the exhaust hood to the outside. Never use an exhaust hood with a magnetic damper.

To permit sufficient air circulation under the exhaust hood, there should be no less than a 12" clearance between the bottom of the exhaust hood and ground. When possible, the exhaust hood should not exhaust directly into a window well. **DO NOT** terminate exhaust under a house or a porch.

If exhaust ductwork must run through an unheated area, the duct should be insulated and sloped slightly down towards the exhaust hood to reduce condensation and lint buildup.

EXHAUST CHECK LIST:

- Exhaust system meets all local codes and exhaust requirements.
- Plastic flexible duct is not used.
- Completely inspected and cleaned all lint accumulation from the interior of the duct run.

NOTE: Whenever hooking up a new dryer to an existing duct system, always inspect the ductwork for any lint accumulations or restrictions.

Failure to do so will hinder the performance of the new dryer.

- Duct is not kinked or crushed.
- The exhaust hood damper opens and closes freely.

Keep the length of the ductwork as short as possible. The longer the duct, the more friction and resistance to air flow. Also, the smoother the inside surface of the duct, the less friction and the greater the air flow. Friction loss can be measured with a manometer (**Figure 1-2**) and should never exceed .90" of water column. This can be measured, with a manometer, at the point where the exhaust duct connects to the dryer. Select Air Fluff, then check to insure the dryer tumbler is empty and the lint filter is clean.

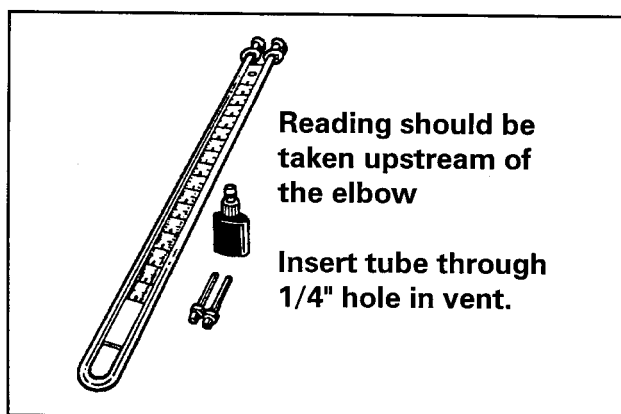

Figure 1-2

A 4" round duct has an area of approximately 12.57 square inches. The area of the duct should never be reduced below this figure.

All exhaust duct joints should be taped to prevent lint and moisture laden air from being expelled into the building.

EXHAUST HOOD TYPE		
Number of 90° Turns		
	4"	2 1/2"
Maximum length of 4-inch diameter rigid metal duct.		
0	65 ft.	59 ft.
1	54 ft.	48 ft.
2	44 ft.	38 ft.
3	36 ft.	30 ft.
4	28 ft.	22 ft.
Maximum length of 4-inch diameter flexible stiff walled metal duct.		
0	36 ft.	28 ft.
1	32 ft.	24 ft.
2	28 ft.	20 ft.
3	25 ft.	17 ft.
4	23 ft.	15 ft.

Figure 1-3

Gas Requirements

THE INSTALLATION MUST CONFORM WITH LOCAL CODES, OR IN THE ABSENCE OF LOCAL CODES, WITH THE NATIONAL FUEL GAS CODE ANSI/Z223.1 LATEST REVISION (FOR THE UNITED STATES), OR WITH THE CAN/CGA-B149 INSTALLATION CODES (FOR CANADA).

A 1/2" gas supply line is recommended and must be reduced to connect to the 3/8" gas line on the dryer. The National Fuel Gas Code requires an approved manual shut off valve be installed within six feet of the dryer. And that a 1/8" N.P.T. (National Pipe Thread) plugged tapping, be installed immediately upstream of the gas supply connection to the dryer, for test gauge connections.

The dryer must be disconnected from the gas supply piping system during any pressure testing of the gas supply lines.

DO NOT reuse old flexible metal gas line.

Flexible gas line must be design certified by American Gas Association (CGA in Canada).

NOTE: Any pipe joint compound used must be resistant to the action of any liquefied petroleum gas.

The dryer uses an automatic ignition system to ignite the burner. There is no constant burning pilot.

Electrical Requirements

GAS DRYER: The dryer is supplied with a power cord, which must be plugged into a grounded 120 volt approved electrical service protected by a dedicated 15 amp fuse or circuit breaker.

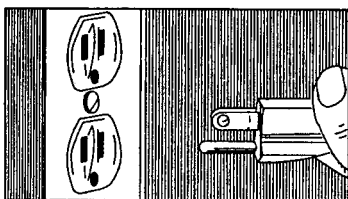

GROUNDING POLARITY CHECKS

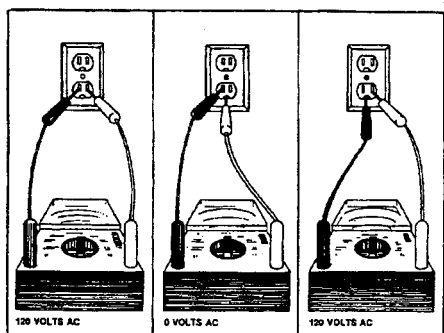

WARNING: For your safety and to protect the test equipment, be sure that the wall outlet is properly polarized and grounded.

ELECTRIC DRYER: U.S. electric model dryers are not supplied with a power cord. Check the data plate of the dryer to determine correct voltage requirements for the dryer.

IMPORTANT: *The dryer frame is grounded to the neutral conductor at the terminal block. If the dryer is installed in a manufactured home, or if local codes do not permit grounding through the neutral, refer to Four Wire System Connections on page 1-5.*

NOTE: *A U.L. listed strain relief must be used with all electrical cable or power cords inserted through the hole provided in the cabinet near the terminal block.*

Three-Wire System Connections

The neutral (white or center wire on the power cord) conductor must always be connected to the center (silver colored) post of the terminal block.

The other two leads of the electrical cable or power cord should be connected to the remaining two posts on the terminal block. Check all terminal nuts for proper tightness.

Four-Wire System Connections

The ground strap should be removed from the terminal block bracket and folded back over the center (silver colored) post of the terminal block. The neutral (white or center wire on the power cord) is connected to the center (silver colored) post of the terminal block.

The green ground wire is attached to the terminal block mounting bracket by the ground strap screw removed earlier.

The other two leads of the electrical cable or power cord should be connected to the remaining two post on the terminal block.

Check all terminal nuts for proper tightness.

WARNING: *If the dryer is being converted from a four-wire system connection to a three-wire system connection, the ground strap folded over the center terminal post must be reconnected to the terminal mounting bracket ground screw. This will ensure the dryer frame is grounded to the conductor of the terminal block.*

SPECIFICATIONS

AIR FLOW	220 cubic feet per minute
CAPACITY	6.0 cubic feet
ELECTRICAL	GAS DRYER-120 Volts, 60 Hz; Requires 15 amp circuit breaker or fused electrical supply, ELECTRIC DRYER-240 Volts, 60 Hz; Requires 30 amp circuit breaker or fused electrical supply. Power cord must be connected to a properly grounded outlet.
MOTOR	1/4 H.P. rated; 120 Volt AC; 60 Hz; Thermoprotected against overload; auto-reset.
HEAT SOURCE	<ul style="list-style-type: none">•ELECTRIC: 240 Volt AC 3-wire; 5300 Watts; 30 Amp fuse/circuit breaker.•GAS: Single port burner; 22,000 BTU/HR; Electric ignition; Automatic shut-off.
TUMBLER SPEED	50 RPM
DIMENSIONS	27"W (68.6CM) x 27.5"D (72.4CM) x 43.25"H (109.9CM)
WEIGHT (Approx.)	Crated - 144lbs. (65 kg); Uncrated - 126lbs. (57kg)

General Component Exploded View

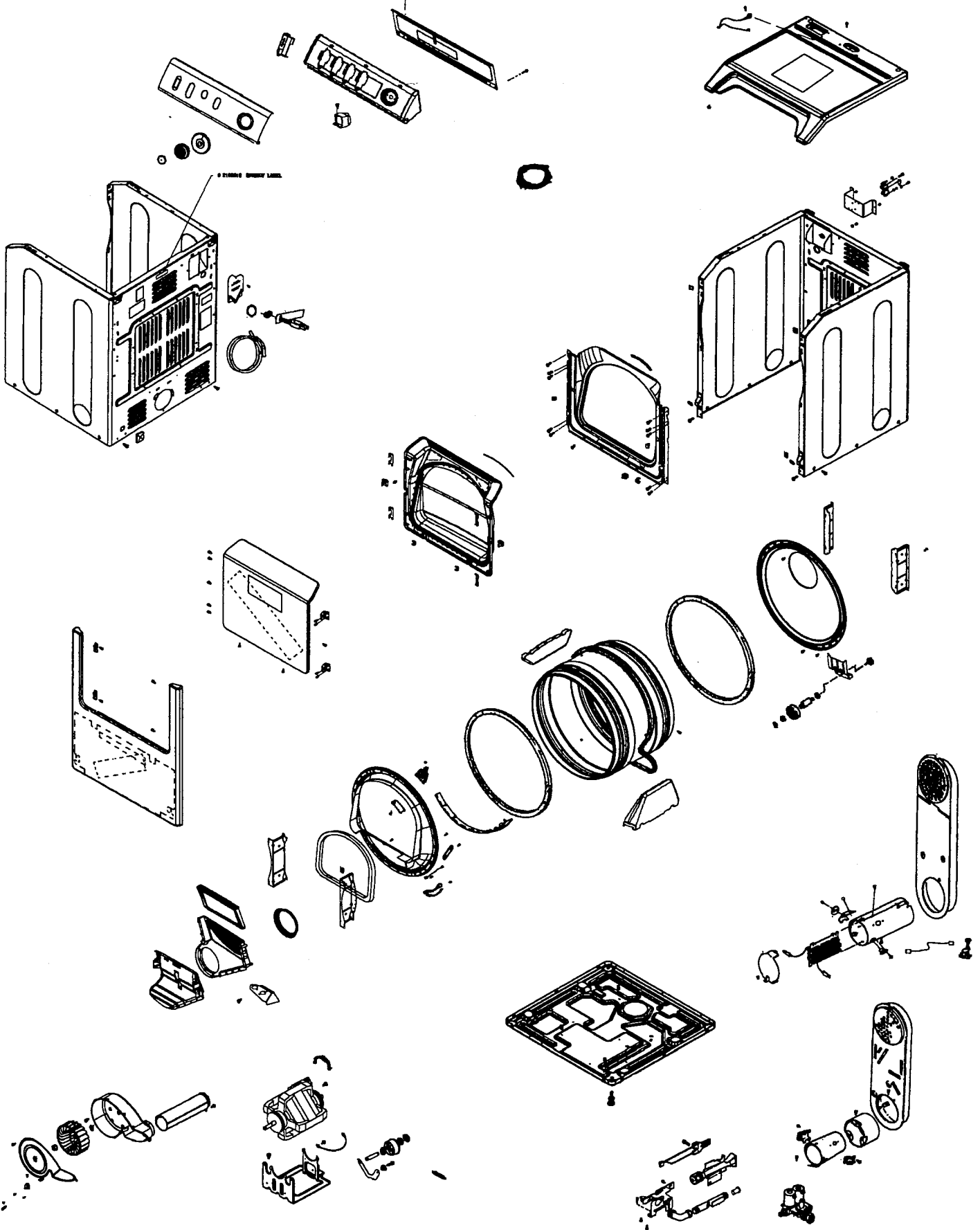

16023110

MDE/DG5500 Facia (LED Screen)

MDE/DG7500 Facia (LCD Screen)

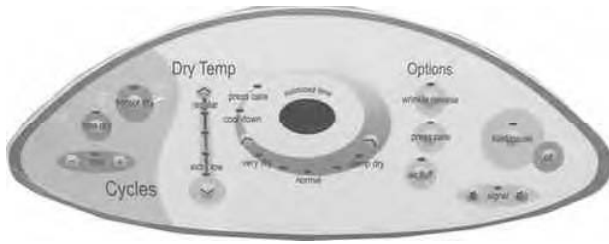

SECTION 2 - ELECTRICAL COMPONENTS & TESTING

TEST EQUIPMENT

The equipment required to service Maytag products depends largely upon the condition you encounter. Locating a malfunction will often require the use of electrical testing equipment such as:

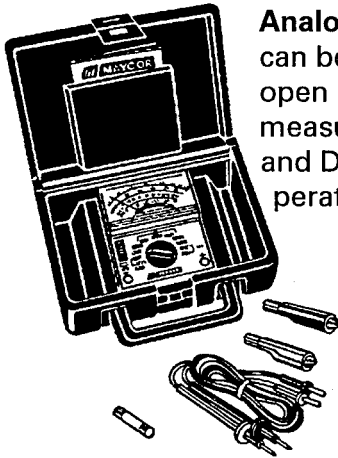

Analog Test Meter

can be used to check for open or closed circuits, measure resistance, AC and DC volts, and temperature.

Digital Test Meter

can be used to check for open or closed circuits, measure resistance, AC and DC volts, and temperature.

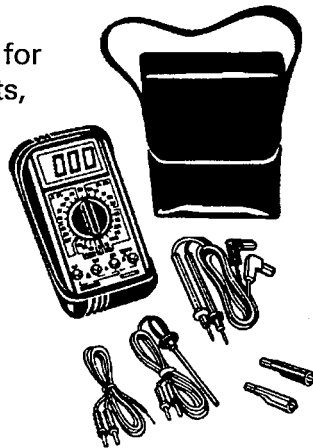

Air Test Meter

can be used to check back pressure in the exhaust duct. Vent restriction can cause back pressure and disrupt normal operations of the dryer.

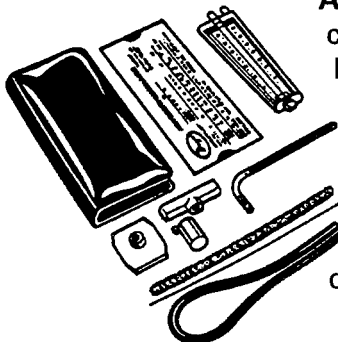

DESCRIPTION	PART NUMBER
Analog Test Meter	20000005
Digital Test Meter	20001001
Clamp-on Ammeter	20000002
AC Voltage Sensor	20000081
Air Test Meter	20000029
Water Column Manometer	038205

Clamp-On Ammeter

can be used to detect shorts. Overloads on the circuit breaker or fuse can be traced to either the dryer or circuit breaker by checking the dryer current draw.

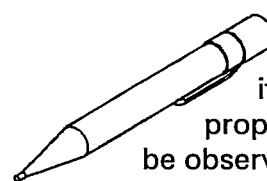

AC Voltage Sensor

can be used to alert you if AC voltage is present so proper safety precautions can be observed. The tip of the sensor will glow bright red, if voltage is between 110-600 volts AC.

Water Column Manometer

can be used to check gas pressure being supplied to the dryer and at the outlet tap pressure on the gas valve.

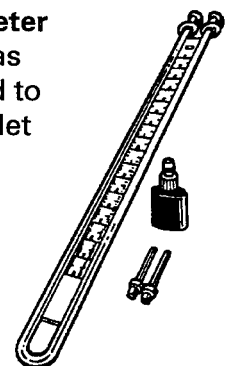

Manometers

An insufficient gas flow can cause problems. Therefore, checking the gas pressure at the time service calls are performed may prevent a call back.

Gas pressure can be checked with and an instrument called a "manometer". This device can tell you if there is a "low" LP tank, restricted gas flow, bad gas valve, a malfunctioning pressure regulator, too many gas appliances operating off of a small supply line, or improperly converted appliance from Natural to LP gas.

Other types of manometers exist, the type of manometer we will discuss in this manual is a "U" shaped tube in which weight is added. Both ends are open so the water can equalize and seek its own level, which of course will be the same in both arms of the "U" shaped tube.

A flexible rubber hose is connected to the lower open end of the manometer and to the gas source. Gas pressure is exerted on only one of the water columns, pushing it down. The water level then would rise in the other column. A measurement of the differential in water levels is then taken as the measure of gas pressure.

The water column (W.C.) for a Maytag dryer is 3.5" W.C. for Natural gas and 11" W.C. for LP gas.

How to Use:

1. Remove front panel.
2. Shut off the gas to the dryer.
3. Install a 5/16" tapered fitting at the gas valve pressure tap. Use thread seal tape or compound on fitting. (*See Figure 2-1*)
4. Fill the manometer tube with water until each side equalizes at "0" water column.

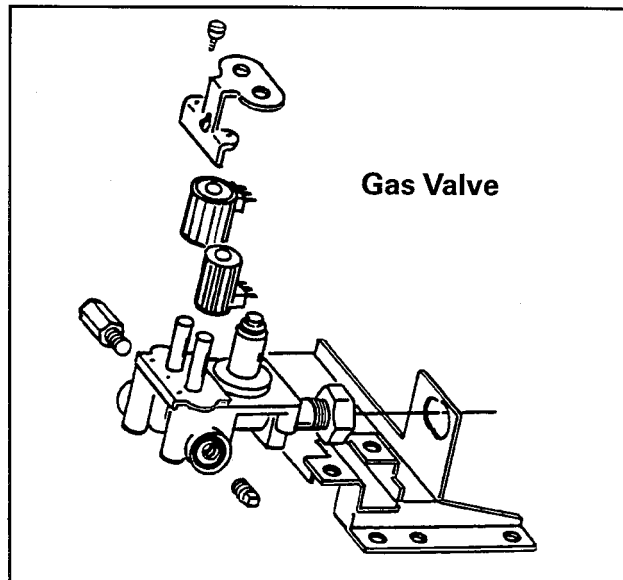

Figure 2-1

5. Push the end of the manometer hose onto the 5/16" fitting, located on the gas valve.
6. Connect hose to one end of the manometer.
7. Turn on the gas and run the dryer in a heat cycle. Read the manometer with the burner ON. (Check for gas leaks)
8. The amount of water column present is equal to the total amount of deflection shown in the manometer, when the gas is turned on.

NOTE: Once test is completed, make sure the tapered fitting is removed from the gas valve and the plug is repositioned into the gas valve and resealed with pipe seal. Check for gas leaks again. This should be done with a soap or bubble solution. NEVER USE OPEN FLAME TO CHECK FOR GAS LEAKS.

IF HIGH WATER COLUMN PRESSURE IS DETECTED; the gas flame can damage the flame spreader on the burner. (This can be caused by the wrong orifice, improper air mixture or high gas pressure. If pressure is as high as suspected, contact the local gas utilities company to check the outside regulator.)

ELECTRICAL TESTS



Warning - Always shut off electrical power to the dryer before beginning any service repair procedures.

Voltage Checks

For the most part these checks will consist of taking readings at the wall receptacle in order to determine the availability of voltage to the product. Voltage checks on individual components of a product are NOT recommended due to the possibility of electrical shock. Component part testing is accomplished through continuity checks with an Appliance Test Meter.

NOTE: Use of the meter on voltage higher than the indicated range may cause permanent damage to the meter. To prevent damage, first select the highest range and then lower the range for readings which fall within the lower scale.

Set up meter for use as follows:

1. Turn selector knob to desired meter function and appropriate range.
2. Plug black lead into socket marked (-) negative.
3. Plug red lead into socket marked (+) positive.
4. Place test leads into receptacle in order to determine voltage available.

Voltage Check with Voltmeter

Voltage readings may be taken by using the leads supplied with the meter. The meter is preset to read on the 0-300 VAC scale but can be dropped down to 0-150 VAC range by depressing the red button on the side of the meter.

Using Voltmeter as a Continuity Tester

While we normally think of continuity testing as only an ohmmeter function, a voltmeter can also be used, particularly when testing switch contacts. The primary difference is that power is applied to the circuit under test and appropriate caution **MUST** be exercised.

The voltmeter is connected across the component terminals with the wires still in place and with power disconnected. The meter is set for the 300 volt range and power is reconnected. A voltage reading indicates a voltage drop across the component. There should be no voltage drop across closed switch contacts or fuses.

The voltmeter connected across thermostat terminal, as an example, will show no reading when the thermostat is calling for heat and will show line voltage when the thermostat cycles if the timer is in heat cycle.

This type of continuity testing is an excellent method of locating questionable switch contacts. Any voltage drop across closed switch contacts indicates poor electrical contact. The resulting internal heating can shorten component life.

Door Switch

The door switch is in series with both the motor and the inner tumbler light. When the door is closed, the switch completes a neutral circuit to the motor and opens the circuit to the tumbler light. With the door open, the light circuit is completed and the neutral circuit to the motor is discontinued, thus shutting the motor down.

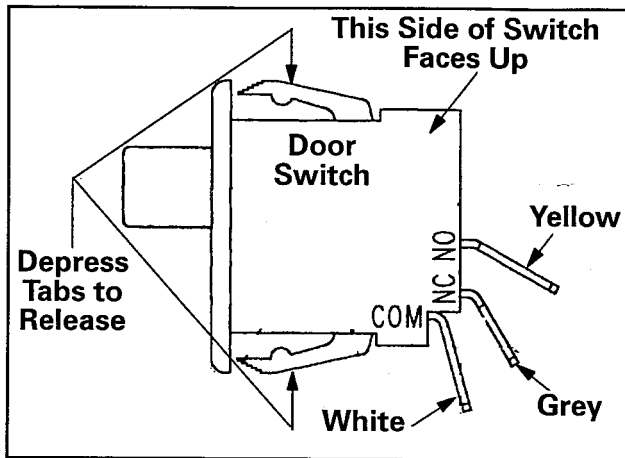

Figure 2-2

To test the door switch, use an ohm meter and check for continuity from the COM terminal to the NO and the NC terminals. "NO" means normally OPEN and with the door switch button not depressed there should not be any continuity until the button is pushed in. By having the switch button out, such as having the door OPEN, the dryer cannot be started.

The "NC" means there should be continuity across the terminals without depressing the button. This occurs when the door is opened, turning the tumbler light ON. When the door is closed, the switch will turn OFF the tumbler light.

Timer & Console Switches

The timer is a series of switches driven by an electric motor. The timer motor rotates a pinion gear which in turn rotates internal cams. As the cams rotate, they lift and drop various switch contacts which ride on the cam. The internal switches control power flow to the motor and the heating element. A timing chart is illustrated on the electrical schematic, found in the control console of the dryer.

Using the timer chart at the top of the electrical schematic, you can identify the timer terminals on the back of the timer, which are involved in various parts of the dryer cycle. With the power OFF and placing the termi-

nals of the ohm meter across the terminals, you can check for continuity across the internal timer contacts.

Drive Motor Check

The motor features a leadless motor connection, comprised of a quick connector wire harness which connects directly to the motor. The connector has two locking tabs securing the connector to the motor switch. Press on both locking tabs to release the connector from the motor switch. (See Figure 2-3)

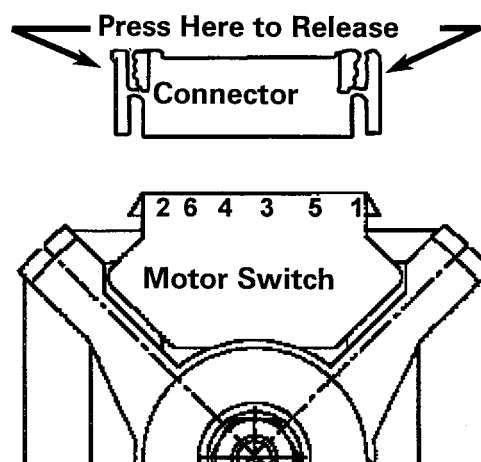

Figure 2-3

With the wire harness connector removed from the motor, and by pressing inward on the brown actuator disc in the motor, the start and run winding can be checked for proper ohms. Placing the leads from an ohm meter on the proper terminals as listed in the following chart. (See Figure 2-4)

Using an ohm meter, you can also check the wiring harness for continuity from the timer to the motor.

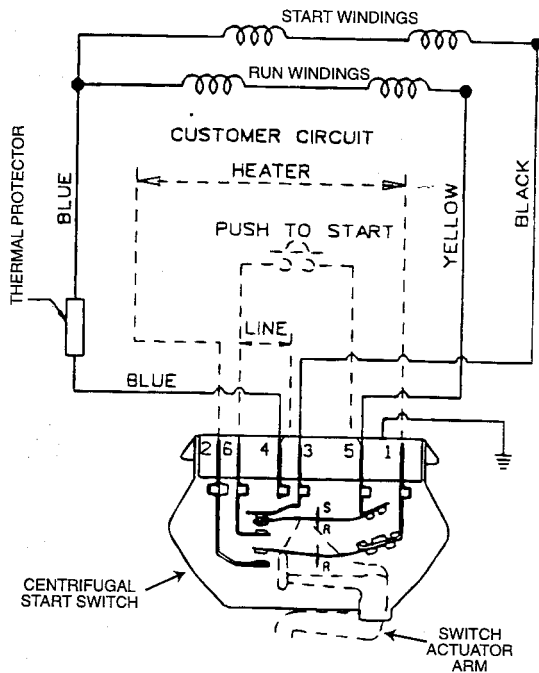

Figure 2-4

Winding	Terminal	Terminal	Ohms
Start	3	4	3.00
Run	5	4	2.25

Motor Test Cord

A motor test cord may be used to electrically check operation of the various electrical components without removing them from the unit. Testing in this manner merely determines whether or not the part will function independently of other electrical components. In order to make an accurate test, proper connection of the motor test cord is important.

Drive Motor Test

The motor may be checked in the dryer or removed and checked on the bench.

Two test leads are required to check operation of the dryer drive motor. To check the motor for operation, hook up the test cord to terminals 4 and 5. (See Figure 2-4)

Centrifugal Switch

Checking heater/gas valve-motor:

1. Disconnect the wire harness from the motor.
2. Place ohm meter leads to terminals 1 and 2. (See Figure 2-4)
3. With your thumbs, depress the BROWN disc located behind the motor switch on the motor shaft. (See Figure 2-5) The BROWN disc actuates the lever of the motor switch when the motor is at rest. At optimum motor speed, the disc moves away from the switch lever. When the disc is pressed inward toward the windings, the actuator arm of the centrifugal switch will be relaxed. This in turn, will allow the contacts to close, completing the heater circuit. If no continuity is found when the disc is depressed, change the centrifugal switch.

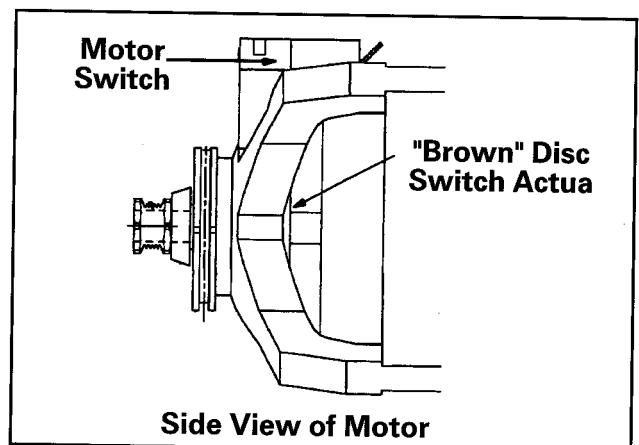
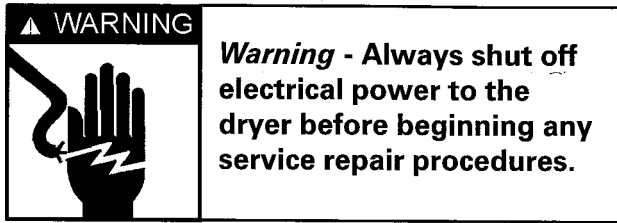

Figure 2-5

ELECTRICAL TESTS LCD/LED Dryers



Grounded Components

When performing service diagnostics, replacements and repairs, always check to determine whether all ground wires linking panel and components are reattached if removed.

Machine Control

The machine control microprocessor board is located in the control console, mounted to the plastic console. The board receives input from the membrane pad/touch screen, door switch, thermistor and sensor bars. The control board controls the motor, gas valve/heater via relays on the board. On the LCD electric dryer only, there is an additional external relay.

Both incoming and exiting voltage is monitored through the machine control board and the surrounding circuitry. The following tables list the voltages for the various terminals on the microprocessor board.

(Figure 2-6)

If proper voltage is not present, check switches and wiring for possible loose connections or open circuits by disconnecting the power supply and performing continuity checks of individual circuits.

The machine control board outputs can be verified by placing the dryer into the Service Mode and performing a System Check Mode Test. **(See Section 9; Service Mode; System Check Mode Test.)**

LCD Dryer

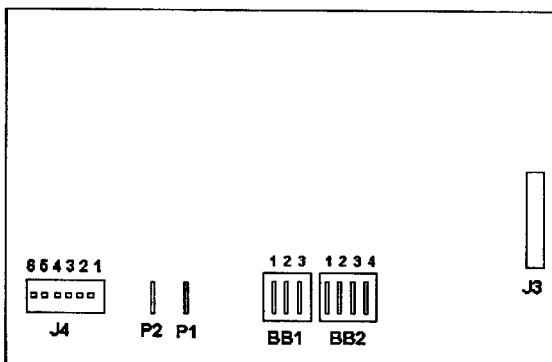

LED Dryer

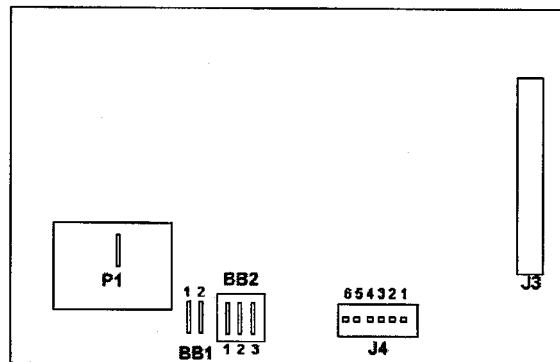
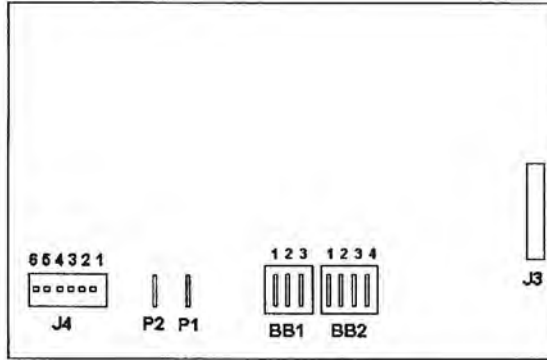

Figure 2-6

INPUT/OUTPUT VOLTAGES

LCD Dryer



Description	Connector Pin Number	Connector Pin Number	Voltage	Comments
Heater Relay - Internal (Output)	P1	P2	24 VDC	
L1 Board (Input)	BB1(1)	BB2(3)	120VAC	Door must be closed.
Motor (Input)	BB1(2)	BB2(3)	120VAC	Door must be closed.
24 VDC (Input)	BB1(3)	BB1(2)	24VDC	(Electric Dryer Only)
Neutral (Input)	BB2(2)	BB1(1)	120VAC	
Heater Relay - External	BB2(1)	BB2(3)	120VAC	Door must be closed. (Electric Dryer Only)
Door Sense	BB2(3)	BB1(2)	120VAC	Door must be closed.
24 VDC (Input)	BB2(4)	BB1(2)	24VDC	
Thermistor	J4(1)	J4(2)	5VDC	NTC 70°F=10K ohms 150°F=1754 ohms
Sensor Bar	J4(3)	J4(4)	24VDC	

LED Dryer

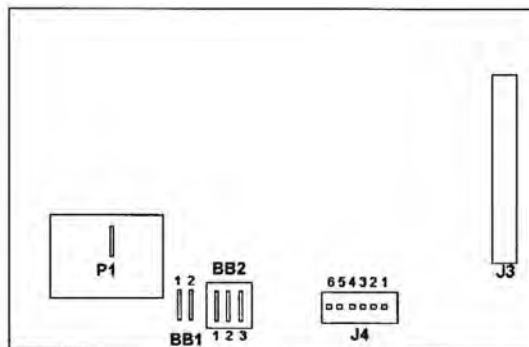

Description	Connector Pin Number	Connector Pin Number	Voltage	Comments
Heater Relay - Internal (Output)	P1	BB1(1)	120VAC	
L1 Board (Input)	BB1(1)	BB2(3)	120VAC	Door must be closed.
Motor (Input)	BB1(2)	BB2(3)	120VAC	Door must be closed.
Neutral (Input)	BB2(2)	BB1(1)	120VAC	
L1 Board (Input)	BB2(1)	BB2(3)	120VAC	Door must be closed.
Door Sense	BB2(3)	BB1(1)	120VAC	Door must be closed.
Thermistor	J4(1)	J4(2)	5VDC	NTC 70°F=10K ohms 150°F=1754 ohms
Sensor Bar	J4(3)	J4(4)	24VDC	

Membrane Pad Checks

On the MDE/DG5500 dryer you can perform the Membrane Pad Check with the control console. (See Section 9: Accessing Service Mode; Membrane Pad Check)

LCD Dryer

Membrane Pad	Pin Number	Pin Number
<i>home</i>	J7(3)	J7(5)
<i>favorites</i>	J7(4)	J7(5)
<i>back</i>	J7(3)	J7(6)
<i>start/pause</i>	J7(3)	J7(7)
<i>off</i>	J7(4)	J7(7)
<i>help</i>	J7(4)	J7(6)

On both dryers, you can check the membrane pads, by pulling the J7 connector from the machine control board and locating the corresponding switch pin numbers in the ribbon harness.

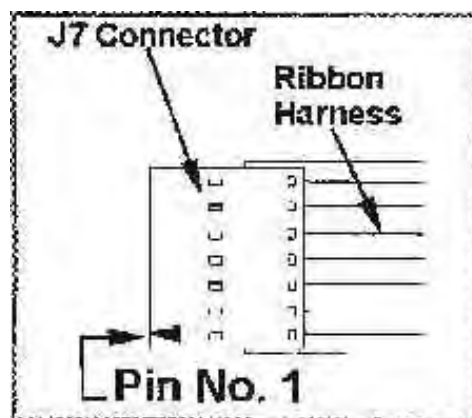

LED Dryer

Membrane Pad	Pin Number	Pin Number
<i>sensor dry</i>	J7(12)	J7(13)
<i>time dry</i>	J7(11)	J7(13)
<i>time (+)</i>	J7(10)	J7(13)
<i>time (-)</i>	J7(9)	J7(13)
<i>Dry Temp (^)</i>	J7(11)	J7(14)
<i>Dry Temp (v)</i>	J7(10)	J7(14)
<i>Dryness(<)</i>	J7(12)	J7(14)
<i>Dryness(>)</i>	J7(9)	J7(14)
<i>wrinkle release</i>	J7(11)	J7(15)
<i>press care</i>	J7(9)	J7(15)
<i>air fluff</i>	J7(10)	J7(15)
<i>start/pause</i>	J7(11)	J7(16)
<i>signal (-)</i>	J7(12)	J7(15)
<i>off</i>	J7(9)	J7(16)
<i>signal (+)</i>	J7(12)	J7(16)

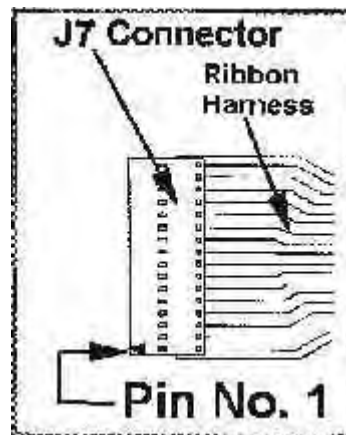

SECTION 3 - TROUBLESHOOTING GUIDE

FUNDAMENTAL CHECKS

Will Not Run

If dryer will not start or run, check the following:

- All wires are hooked up to their corresponding terminals.
- Dryer is plugged in.
- Blown fuse or circuit breaker.
- Door switch functional...door closed.
- Push-to-start switch functional.
- Timer functional...set in a cycle.
- Drive motor functional.
- Blown thermal fuse.

If drive motor runs, but the tumbler will not turn, check the following:

- Belt off or broken/damaged.
- Idler tension spring too weak or stretched.
- Idler pulley jammed or stuck.

If dryer runs a few minutes and then stops - motor overload protector opens, check the following:

- Lint buildup around drive motor.
- Low voltage present.
- Blower impeller blocked in blower housing.
- Drive motor - start switch contacts stuck closed.

If dryer blows fuses or trips circuit breaker, check the following:

Electric Models

- The amperage readings are at 240 volts. One line will be 24 amps and other line will be 21 amps. The neutral line will be at 3 amps. If the above amperages are present, then the house wiring, fuse box or circuit breaker should be suspected.
- Shorted heating element to housing.

- Incorrect wiring or a wire shorting to ground.
- Drive motor winding shorting to ground.

Gas Models

- During ignition the dryer will draw 7 amps. With the burner ON, the dryer will draw 3 amps. If the dryer is drawing amperages above this, then the house wiring, fuse box or circuit breaker are suspected to be at fault.
- Igniter harness loose and shorted to base.
- Incorrect wiring or wire shorted to ground.
- Drive motor winding shorting to ground.

Will Not Dry

If dryer will not heat (motor runs), check the following:

- Open heating element.
- Hi-Limit thermostat trips too soon or is open.
- Regulating thermostat trips too soon or is open.
- Temperature selector switch miswired or contacts open.
- Timer functional.
- Cycle selector switch miswired or contacts open.
- Drive motor centrifugal start switch not allowing voltage to gas valve or heating element.

If improper drying/clothes wrinkled/ rough texture/taking too long to dry, check the following:

- Lint filter is not clean.
- Restriction in exhaust.
- Outside exhaust hood damper door stuck closed.
- Exhaust too long, too many elbows, flex ductwork installed.

- Poor makeup air available for the dryer.
- Incorrect tumbler speed. Tumbler belt slipping.
- Blower impeller bound; check for foreign material in blower area.
- Customer overloading dryer.
- Check clothing labels for fabric content and cycle selected.
- Gas valve coil opens - weak point in coil opens when stressed under heated conditions.
- Clothes too wet due to insufficient spin out by washer.

Will Not Shut-Off

On time dry settings check the following:

- Timer motor receiving proper voltage.
- Check timer motor connections.
- Timer functional.

On Intelli-Dry settings, check the following:

Note: *The Intelli-Dry dryer incorporates a new "simplified" electronic control system using a PTC (Positive Temperature Control) thermistor. A PTC is a thermistor that will change resistance at predictable temperatures and induce variable current flows.*

Function of dryer's electronic control unit with a:

Wet Load- Wet clothes making contact across sensor bars allows current path to ground. This allows current to pass across the PTC thermistor on the electronic control unit. Current passage through the thermistor heats up the thermistor and raises the resistance of the thermistor, in turn creates a voltage drop through the thermistor. This then leaves less than the required voltage available for the timer motor. The timer motor stops and cannot run.

Dry Load - Since dry clothes do not conduct electricity, current path to ground is inhibited and voltage across the thermistor is dropped. In turn, the thermistor cools and the resistance drops, reducing the amount

of voltage drop across the thermistor, resulting in more voltage drop across the timer motor. Timer will now run.

Troubleshooting the electronic control circuit:

- Check for miswiring of the molex connector at the electronic control board.
- If the dryer does not shut off, then the problem is in the electronic control unit. Disconnect the sensor wire from the sensor bar. If the dryer runs for about 20 minutes, then shuts down or the timer advances, then the electronic control unit is good and the problem lies in the sensor bar.
- Check sensor for continuity. If found, replace sensor bar or clean with alcohol. Some fabric softener sheets will coat the sensor bars.

Noisy and/Or Vibration

- *Thumping.* Check for loose tumbler baffle, rear tumbler roller(s) worn or misaligned, out-of-round tumbler or high weld seam on tumbler.
- *Ticking.* Check for loose wire harness or object caught in blower wheel area.
- *Scraping.* Check for front or rear bulkhead felt seal out of position or worn tumbler front Rulon™ bearings.
- *Popping or squealing sound.* Check for a sticky or frayed belt.

DIRECT IGNITION SYSTEM

Testing and observation of the gas controls system can be performed with the front panel removed and the door assembly mounted and secured to the front shroud.

When the dryer is operated on a heat setting, the igniter should be energized and burner shall fire within 45 seconds at 120 VAC. Check for the existence of the flame. De-energize the gas control and reenergize. The flame should reappear within one minute.

The failure of a component in this system will usually be indicated by one of three symptoms:

1. **The igniter does not glow.** If the igniter does not heat up, remove power and using an ohmmeter, check the following:
 - Open flame sensor
 - Open igniter
 - Shorted booster coil
 - Open wiring

2. **Igniter glows - No gas ignition.** If the igniter heats up but the main burner flame is not ignited, remove power and using an ohmmeter, check the following:
 - Open secondary coil
 - Open holding coil
 - Open wire harness

3. **The gas is ignited but the flame goes out.** If a normal ignition takes place and after a short while the flame goes out, check for the following:
 - Radiant sensor contacts opening prematurely.
 - Weak gas valve coil may open when stressed by higher temperatures.

SECTION 4 - CONSOLE ASSEMBLY

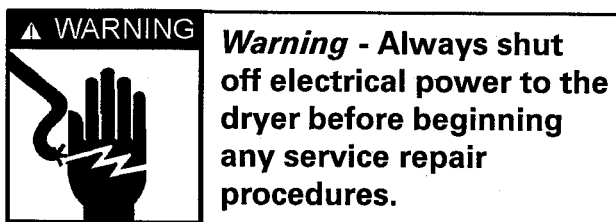

REMOVAL

1. Disconnect power to the machine.
2. Remove the three screws securing the console rear cover plate across the rear top edge of the console. (See Figure 4-1)

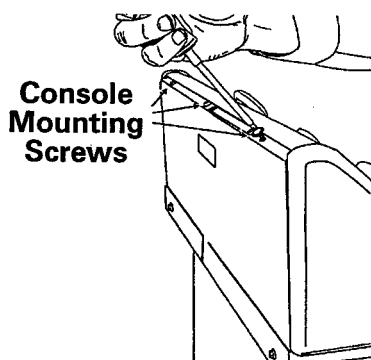

Figure 4-1

3. Lay a dropcloth across the top cover of the dryer.
4. Grasp the top of the console and gently rock the top of the console forward. (See Figure 4-2)

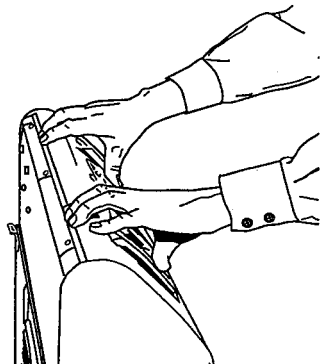

Figure 4-2

5. Roll the top of the console forward. (See Figure 4-3)

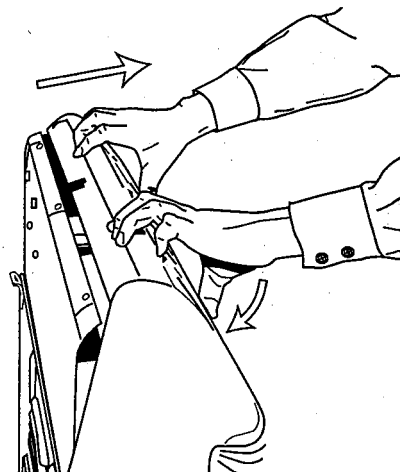

Figure 4-3

6. Carefully lift and roll the console forward onto the top cover. You now have access to the console components and wiring. (See Figure 4-4)

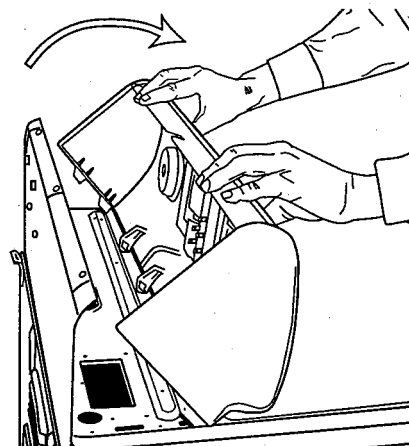

Figure 4-4

7. **To Reinstall:** Roll the console back into an upright position, engaging the locking feet into the slots in the top cover. Replace the three screws to attach console back to console rear panel.

VERTICAL SWITCHES (Push Button)

1. **To remove** - Depress the tab at the top of the switch with a screwdriver to disengage the tab from the console, then pivot the switch away from the console to remove. (See Figure 4-5)
2. **To replace** - Align the rib on the bottom of the switch with the slot in the console, then pivot the switch up into the console until the tab engages the console securely. Check to be sure the locating tabs on either side of the switch's lower alignment rib are in position to properly center and lock the switch into the lower part of the console switch opening.

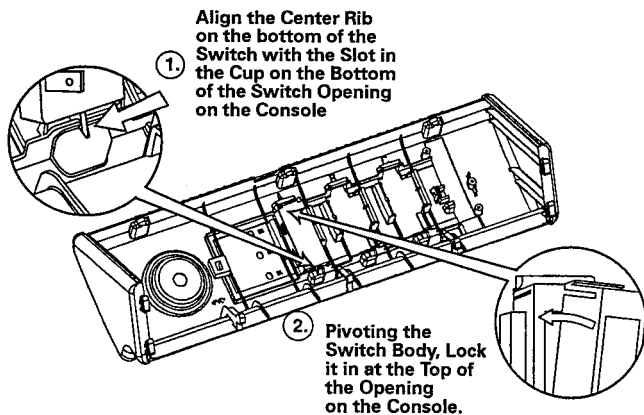

Figure 4-5

HORIZONTAL SWITCHES (Push-to-Start)

1. **To remove** - Depress the locking tab on the switch to disengage the switch from the locking tab on the console. Pivot the switch from the console. (See Figure 4-6)
2. **To replace** - Position one side into the console and pivot the other tab into the console and apply enough pressure to engage the tab into the console.

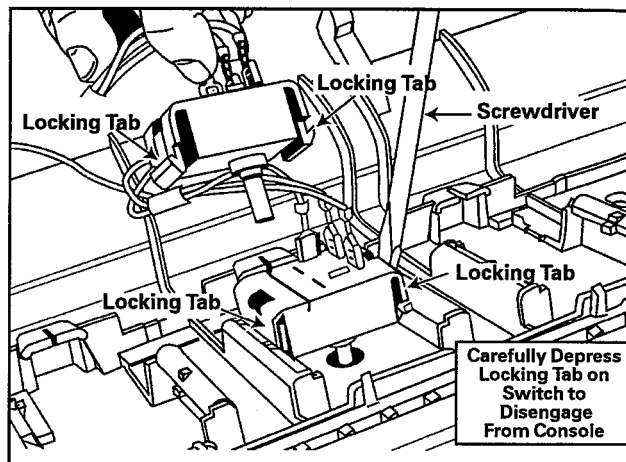

Figure 4-6

TIMER REMOVAL

1. Disconnect power to the machine.
2. Carefully lift the timer knob and dial off the timer shaft by pulling the knob away from the face of the control console. (See Figure 4-7)

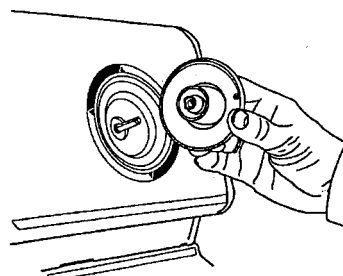

Figure 4-7

3. Remove the two timer mounting screws (now exposed on the control console) when the timer dial skirt is removed.
4. Disengage the console assembly from the top cover and roll forward. (See Console Assembly)

MODELS: MDE/DG5500, 7500

CONSOLE WITH MEMBRANE PAD



The replacement console assembly consists of the console, medallion and membrane pad.

CONSOLE REMOVAL

1. Disconnect power to the unit.
2. Remove the four screws securing the console to the rear cover plate.

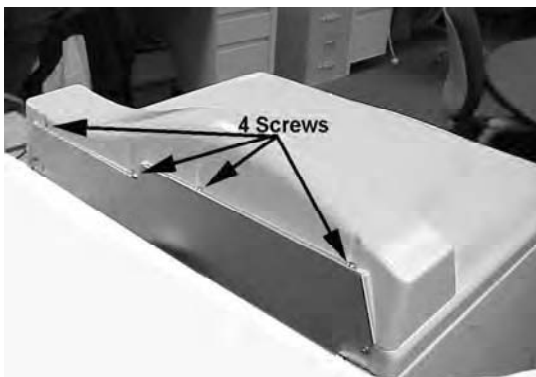

Figure 4-8

3. Lay a drop cloth across the top cover of the washer.
4. Grasp the top of the console and gently rock the top of the console forward away from the rear console back. Note the hooked tabs on bottom of the console, which engage the slots in the top cover.



Figure 4-9

5. For reinstallation, reverse the aforementioned steps.



Figure 4-10

MICROPROCESSOR BOARD REMOVAL

1. Disconnect power to the dryer.
2. Remove the console assembly.
3. Carefully remove the membrane pad harness and other wires from the microprocessor board.



Figure 4-11

SECTION 5 - CABINET ASSEMBLY COMPONENTS

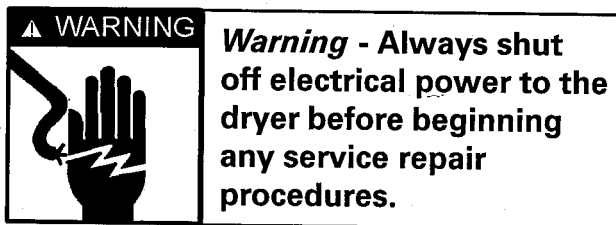

DOOR ASSEMBLY & HINGES

The door assembly is reversible.

Removal

1. Open the door and remove the center screw of each hinge secured to the inner flange of the front panel in the door opening. (See Figure 5-1)

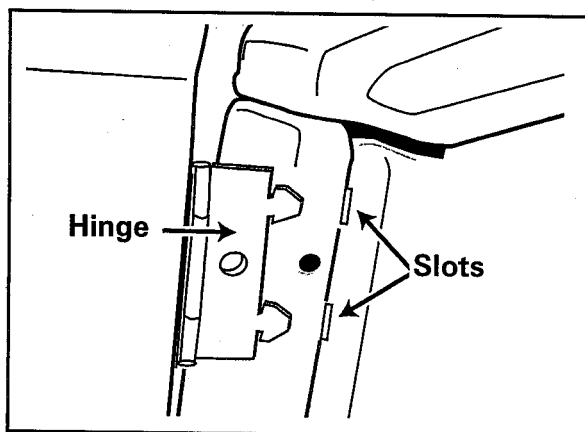

Figure 5-1

2. Grasp the door with both hands and lift the door in the hinge area and draw the door assembly away from the machine. This will disengage the hinges from the slots in the front shroud.

Reversal

1. Remove the door assembly from the dryer, then remove the plastic hinge hole covers on the opposite side of the door opening.

2. Remove the hinges from the door itself and relocate them to the other side of the door.
3. Remount the door into the slots on the opposite side of the door opening in the front shroud and secure with one screw into each hinge.
4. Mount the plastic hinge hole covers onto the side the hinges were previously on, to cover the slots in the front shroud.

Door Disassembly

1. Remove ten screws located across the bottom and along either side of the door panel. The top edge of the outer panel is folded over the inner door plug.

FRONT PANEL

Removal

1. Open the door and remove the four screws along the inside lip of the door opening. (See Figure 5-2) Two are located vertically on either side of the door opening. These screws secure the front panel to the front shroud assembly.

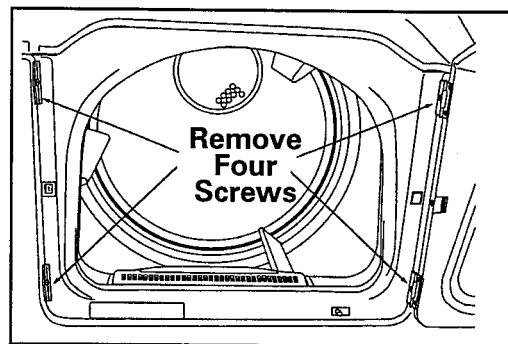

Figure 5-2

- The front panel is held to the cabinet by means of clips secured to the front shroud. Small slots in the front panel engage the clips and hold the front panel in place. (See Figure 5-3) To remove the front panel, grasp the goal posts of the front panel 3/4 of the way down and pull front panel away from the dryer.

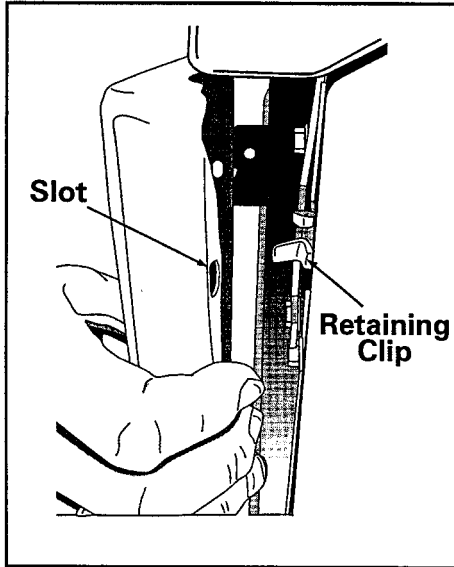

Figure 5-3

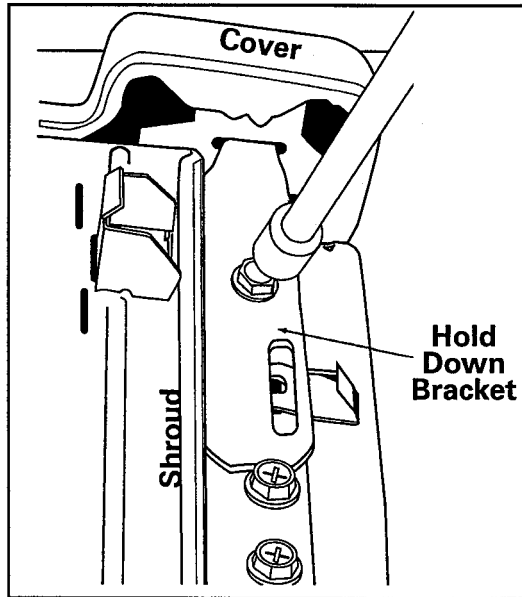

Figure 5-4

- Tilt the top of the front panel away from the machine and lift the panel off two clips retaining the front panel to the base frame. Set the front panel away from the machine.

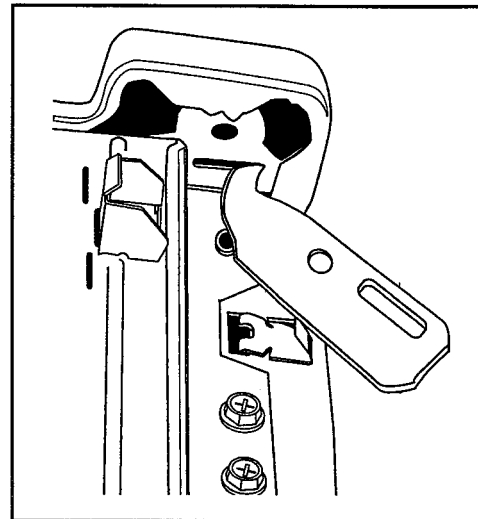

Figure 5-5

TOP COVER

Removal:

- Remove the front panel. (See Front Panel Removal)
- Locate and remove two 5/16" hex head screws securing the two hold down brackets for the top cover. (See Figure 5-4)
- To remove the hold down brackets, swing the bracket to the outside and unhook the bracket from the slot in the top cover lip. (See Figure 5-5)
- If the door is still positioned on the front shroud, open the door prior to lifting the front of the top cover and tilt the top cover toward the rear of the machine.

SECTION 6 - TUMBLER & BULKHEADS

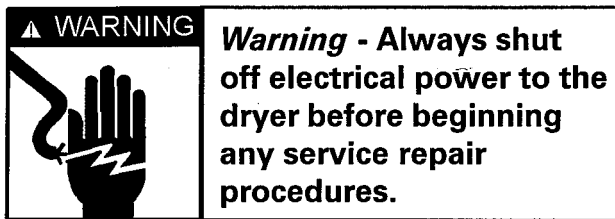

SHROUD & TUMBLER FRONT ASSEMBLY

The shroud and tumbler front assembly holds the front of the tumbler in the correct position and provides support for the teflon bearing surfaces for the front of the tumbler to ride on. The air outlet duct with lint filter is located in the assembly and channels the air from the tumbler into the blower assembly.

Removal

1. Disconnect power to the machine.
2. Remove front panel and door assembly.
3. Remove wires from door switch, sensor bar and lamp holder, then unsnap the lamp holder wire harness from the front shroud wire retaining clip.
4. Remove four outer perimeter screws holding shroud and tumbler front assembly to the cabinet.

NOTE: *Remove the lowest outside screw at each corner and then the top screw on each side. Leave the four inner screws in place. (See Figure 6-1)*

5. Pull shroud and tumbler front assembly out and away from tumbler, while partially lifting the top cover.

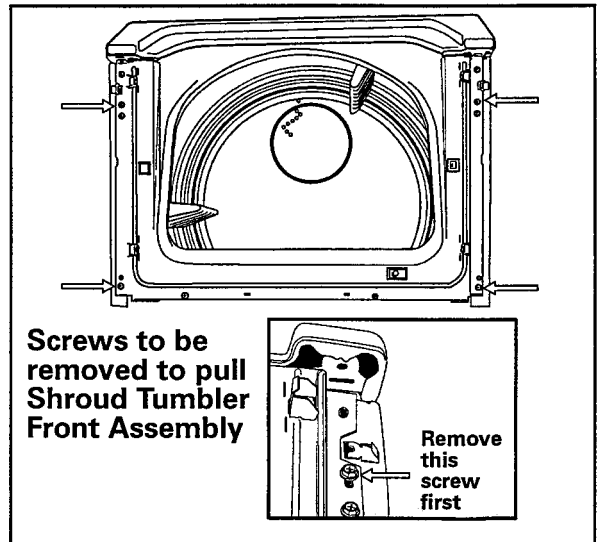

Figure 6-1

Reinstall

1. Reverse the previous steps.

NOTE: *When reinstalling the shroud and tumbler front assembly, lift the front inner edge of the tumbler to allow the front of the tumbler to rest on the teflon (Rulon™) bearings on the shroud and tumbler front assembly. Also, check the front felt seal, to ensure the felt seal is outside the lip of the tumbler.*

Disassembly of the Outlet Duct, Shroud and Tumbler Front

1. Remove the shroud and tumbler front assembly from the dryer.
2. Remove the four 1/4" hex head screws securing the outlet duct to the front shroud support.

NOTE: *Two screws are hidden under the felt seal. (See Figure 6-2)*

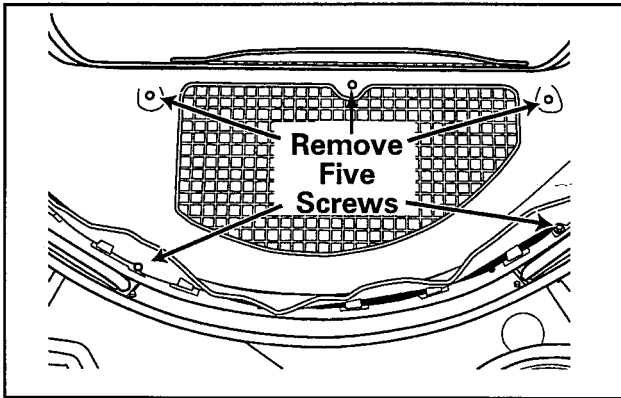

Figure 6-2

3. Remove two screws along the bottom of the front shroud. (See Figure 6-3)

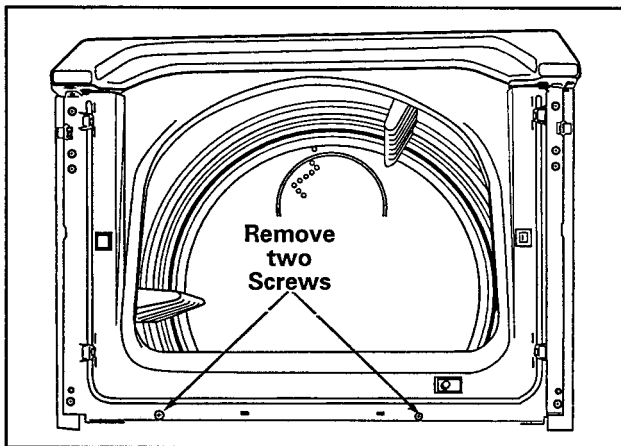

Figure 6-3

4. When reattaching the outlet duct assembly to the tumbler front, install the center screw (found above the grid area) first, followed by the four outside screws in any order. (See Figure 6-4)

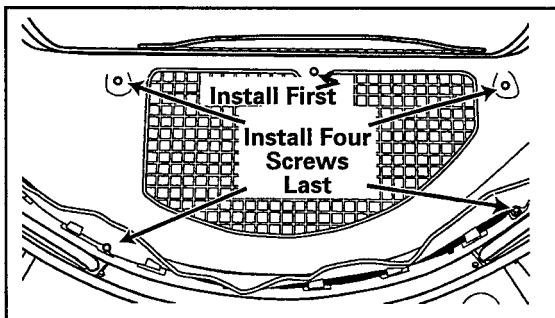

Figure 6-4

LINT FILTER

The lint filter is one piece and can be removed for cleaning. (See Figure 6-5)

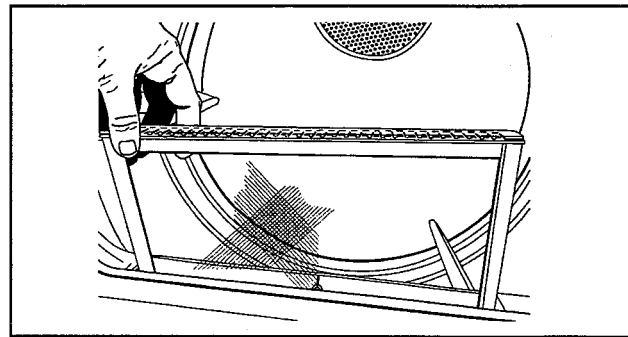

Figure 6-5

BEARING & PADS

At the bottom inside of the shroud and tumbler front assembly there are two teflon (Rulon™) bearings which rest on cork pads. These bearings provide a surface for the front of the tumbler to ride on.

Removal & Replacement:

1. Disconnect power to the machine.
2. Remove the front panel and shroud/tumbler front assembly.
3. Drill out the old rivets and rivet new bearings in place. In positioning the bearing and cork pad, the face of the bearing should ride against the tumbler. This allows the bearing to stick out beyond the metal of the tumbler front. (See Figure 6-6)

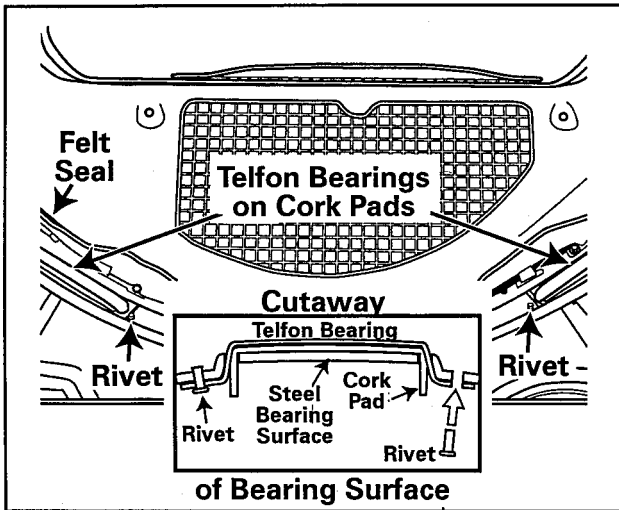

Figure 6-6

TUMBLER FRONT SEAL

The seal fits around the back circumference of the shroud/tumbler front assembly. It is a natural felt seal which is doubled over in order to spring load the seal against the tumbler. The surface which comes in contact with the revolving tumbler is coated with a layer of teflon to provide a slick durable wear surface.

Removal

1. Disconnect power to the machine.
2. Remove the front panel and shroud/tumbler front assembly.
3. Remove the old felt seal by prying the locking tabs up with a flat blade screwdriver. (See Figure 6-7)

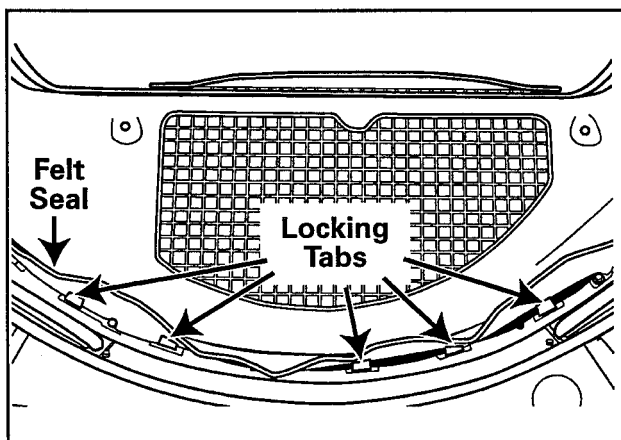

Figure 6-7

NOTE: Pay close attention to the location of the seal overlap. This will be important as you reinstall the new seal.

Reinstall

The seal will be mounted to the shroud in a clockwise rotation. Start at the 3:00 position and place under the locking tabs. The seal will overlap 1 1/4". The coated side (which is the lighter of the two colors) goes against the tumbler. The felt seal is then looped in a "U" shape so that the lighter colored side is against the tumbler front as it is slid in place under the tabs.

Bend tabs back over the felt seal with a flat blade screwdriver.

TUMBLER & BELT

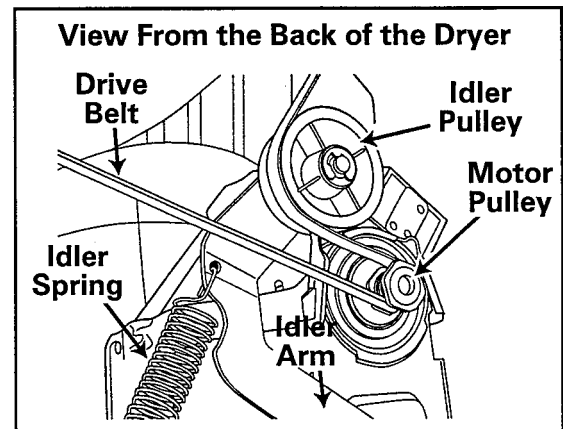

Figure 6-8

The tumbler is a cylinder with no attached front or back. Tumbler speed is 52 R.P.M. Installation can be made without regard to which way it came out of a dryer.

To Remove Tumbler and Drive Belt

1. Disconnect power to the machine.
2. Remove front panel and door.
3. Remove shroud/tumbler front assembly.

- Sit or kneel near the front of dryer. Insert left hand along side of tumbler at the 8 o'clock position. Insert right arm under tumbler (as close to blower as possible).
- Grasp the idler pulley in left hand, pull idler upward and to the left.

Note: *There is a built-in stop to prevent overstressing of the idler arm spring.* Slip belt off the motor pulley. (See Figure 6-9)

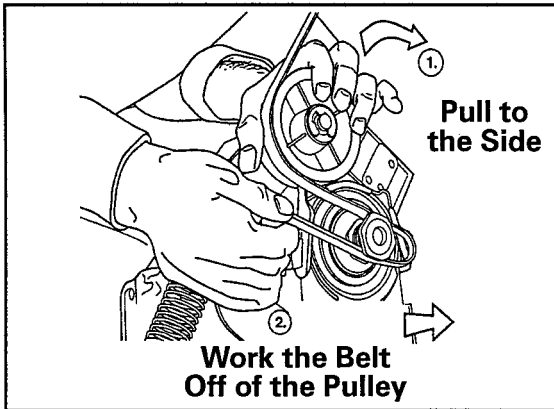

Figure 6-9

- Slip the belt off the back of the tumbler.
- Pull tumbler out of cabinet while lifting top cover.

Installing Drive Belt

- Disconnect power to the machine.
- Place belt onto the outside of the tumbler and position the belt 1 1/2" in front of rear baffle mounting screws with ribbed side against tumbler. (See Figure 6-10)

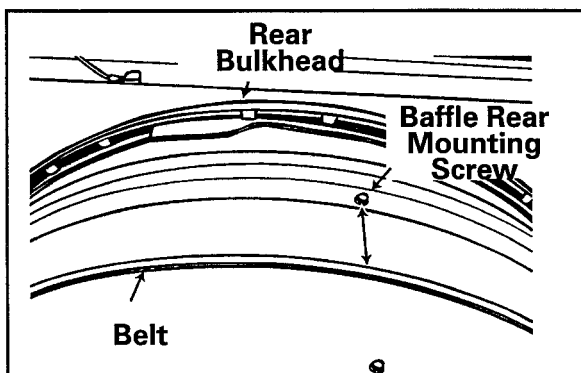

Figure 6-10

- Position tumbler into the rear felt seal, resting the tumbler onto the rear rollers. Lower the front of the tumbler onto the blower housing.
- Sit or kneel near the front of dryer. Insert left hand along side of tumbler at 8 o'clock. Insert right arm under tumbler (as close to blower as possible).
- Locate the belt and create a small loop with your right hand, ensuring the belt is free of twist.
- Position the open end of the loop (ribbed side down) onto the motor pulley with your right hand.
- To clear the drive belt, grasp the idler pulley in left hand, pull idler upward and to the left.

NOTE: *There is a built-in stop to prevent overstressing of the idler arm spring.*

- Relax your left hand and allow the idler pulley to rest down onto the belt.
- Grasp baffles with both hands and rotate tumbler 1 or 2 turns clockwise to allow the belt to align itself.

BAFFLES

There are three tumbler clothes baffles used to aid in tumbling the clothes. Two of the baffles are 1" higher than the other. Location makes no difference.

Removal

- Disconnect power to the machine.
- Remove door and front panel.
- Lift the top cover.
- Rotate the tumbler until the baffle screws of the baffle to be removed appear at the top of the tumbler.

- Remove two screws holding the baffle to the tumbler.

TUMBLER BACK ASSEMBLY

The inner wall of the tumbler back or rear bulkhead is coated with an epoxy powder coat which is a very smooth surface, resistant to scratches and abrasion.

The tumbler back assembly acts as a support for two roller assemblies which support the tumbler and weight of the load.

Removal

- Disconnect power to the machine.
- Remove front panel and door.
- Remove shroud/tumbler front assembly.
- Remove tumbler and belt.
- Remove burner and igniter on gas models. (Be careful, the igniter is fragile).
- Remove heat enclosure.
- From back of dryer, remove four screws holding tumbler back assembly and remove assembly. (See Figure 6-11)

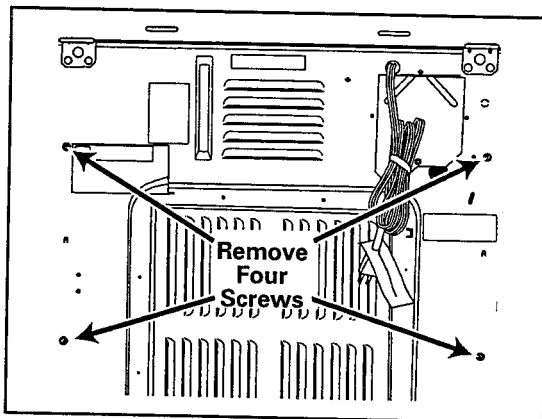

Figure 6-11

TUMBLER BACK SEAL

The felt seal fits around the front circumference of the tumbler back. It is a natural felt seal which is doubled over in order to spring load the seal against the tumbler. The surface which comes in contact with the revolving tumbler is coated with a layer of teflon to provide a slick, durable wear surface.

Removal

- Disconnect power to the machine.
- For ease in servicing, we recommend removal of the tumbler back assembly from the dryer. This will ensure the felt seal is secured properly.
- Remove the old felt seal by prying the locking tabs out with a flat blade screwdriver. Pay close attention to the location of the seal overlap. This will be important as you reinstall the new seal.

Reinstall

The seal will be mounted to the shroud in a clockwise rotation. Start at the 11:00 position and place under the locking tabs. The seal will overlap 1 1/4". The coated side (which is the lighter of the two colors) goes against the tumbler. The seal is then looped in a "U" shape so lighter colored side is against the tumbler back as it is slid in place under the tabs. Bend tabs back over seal with a flat bladed screwdriver. (See Figure 6-12)

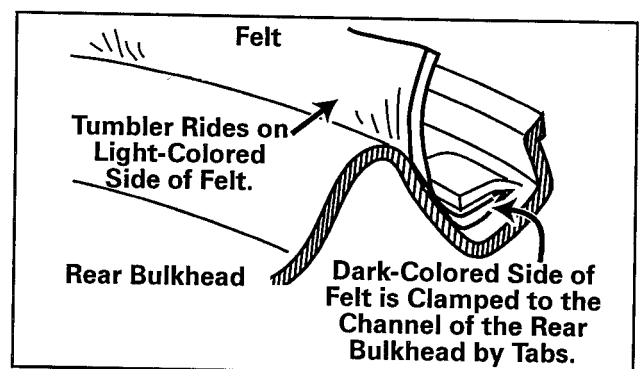

Figure 6-12

ROLLER AND BEARING ASSEMBLY

The tumbler roller consists of a rubber tire bonded to a plastic hub. There are two roller and bearing assemblies attached to the tumbler rear. If the rollers are riding up on the tumbler radius, check for bent rear roller brackets. If a bracket is bent, replace the tumbler back assembly. Rear rollers are self lubricated sintered bearings (lubricate using Maytag SBL oil, P/N 055975).

Removal

1. Disconnect power to the machine.
2. Remove front panel and door.
3. Remove shroud/tumbler front assembly.
4. Remove tumbler.
5. Remove retaining ring from groove in shaft.
6. Remove fiber washer.
7. Remove roller.
8. Remove roller shaft by removing nut on back.

NOTE: *There is a spacer washer behind the roller. When replacing parts be certain of the order of the replacement. (See Figure 6-13)*

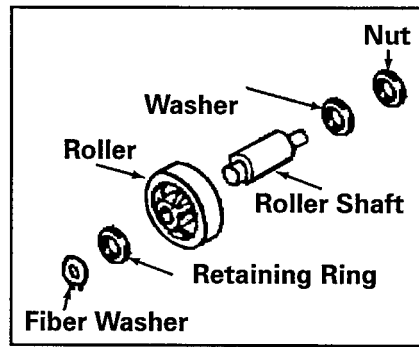

Figure 6-13

SECTION 7 - BLOWER & MOTOR DRIVE SYSTEM

WARNING



Warning - Always shut off electrical power to the dryer before beginning any service repair procedures.

CYCLING THERMOSTATS

The cycling temperature thermostat is located on the blower housing cover. This thermostat cycles at approximately 150° F. (See Figure 7-1)

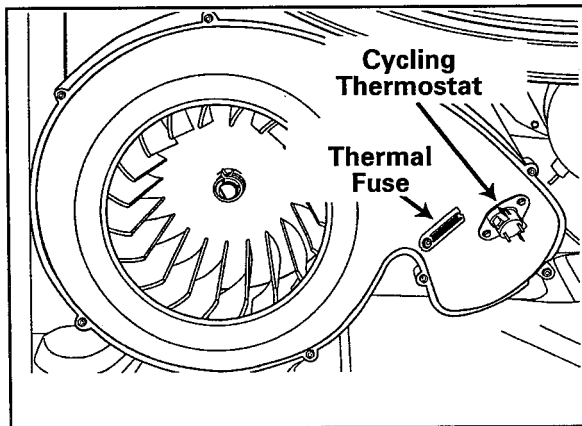

Figure 7-1

Removal

1. Disconnect power to the machine.
2. Remove front panel and close the door.
3. Remove the screws securing the thermostat to the cover.
4. Remove wires from thermostat.
5. Remove thermostat and replace with new part.

HI-LIMIT THERMOSTAT

The Hi-limit thermostat in the dryer is located on the heater enclosure. The thermostat is located close to the heating source and in the event of an over heating condition, will shut off heat quickly. If a dryer is found to be cycling on the hi-limit, check for an air flow restriction. (Gas hi-limit thermostats are rated at 220°F and the electric dryer hi-limit is rated at 200°F)

Removal

1. Disconnect power to the machine.
2. Remove front panel.
3. Remove wires from the thermostat.
4. Loosen the rear mounting screw and remove the front screw. The mounting tabs of the thermostat are open slotted for easy replacement.
5. Slide thermostat out and replace.

THERMAL FUSES

The function of the thermal fuse is to stop the dryer in an overheating condition. The electric dryer has two thermal fuses; one mounted on the blower cover is rated at approximately 180°F (84°C) and the other thermostat, mounted on the left side of the heater enclosure is rated at approximately 240°F (117°C). The gas dryer has one thermal fuse rated at approximately 180° F (84°C) and mounts to the blower cover. The thermal fuses for both dryer types are placed in series with the drive motor. If any of the fuses should open, the drive motor will stop and the circuit through the centrifugal switch for the gas valve/heating will also open, breaking the heat circuit. The fuses will not reset and must be replaced after the overheating problem is corrected. Check for welded contacts in either the cycling or hi-limit thermostats.

Removal

1. Disconnect power to the machine.
2. Remove front panel.
3. Disconnect the wires from the fuse.
4. Remove the screw, attaching the fuse to the blower cover.
5. For the fuse mounted on the heater enclosure. **(Electric dryer only)**
 - Remove the screw that secures the fuse bracket to the heater enclosure.
 - Remove wires and the two screws that attached the fuse to the bracket.

Checking the thermal fuse

1. Disconnect power to the machine.
2. Remove front panel.
3. Remove wires from the thermal fuse.
4. Check for continuity. Attach meter across the terminals of the fuse. If there is no continuity, replace fuse.

BLOWER ASSEMBLY

Seal for Blower

This rubber seal is secured to the outlet duct opening. The seal is fitted around the outer circumference lip of the outlet duct with the flange of the seal facing the blower cover. When installing the shroud/tumbler front assembly, be sure the seal is in place. **(See Figure 7-2)**

Cover for Blower

Removal:

1. Disconnect power to the machine.

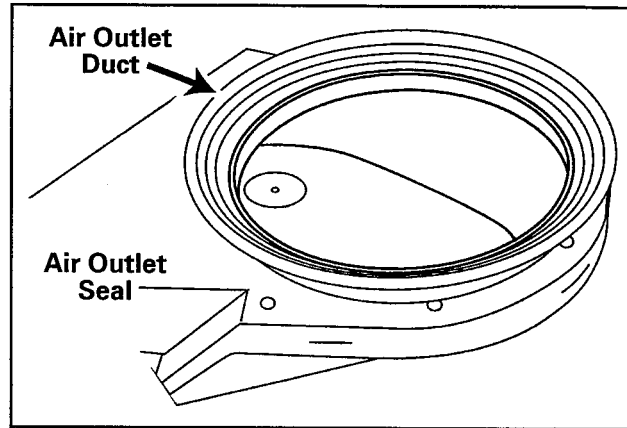

Figure 7-2

2. Remove eight screws holding cover to blower housing. **(See Figure 7-3)**

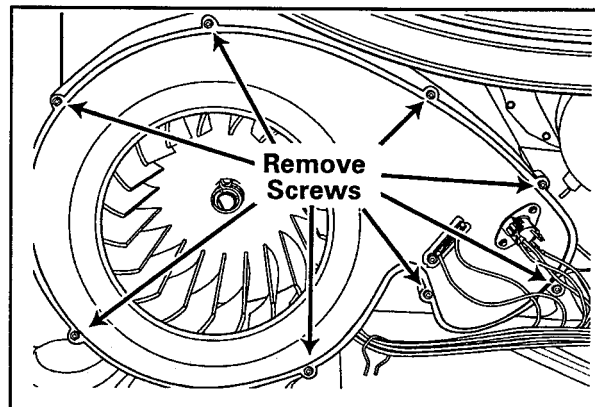

Figure 7-3

3. Remove one screw holding cover to base.
4. It is not necessary to remove wires from thermostats to gain access to blower wheel. Lay the blower cover aside.

Installing Blower Cover

1. Disconnect power to the machine.
2. Set the blower cover in place.
3. Install the first screw closest to the exhaust duct (right most screw). **(See Figure 7-4)**
4. Continue to assemble, moving to the next screw in a clockwise motion around the blower.

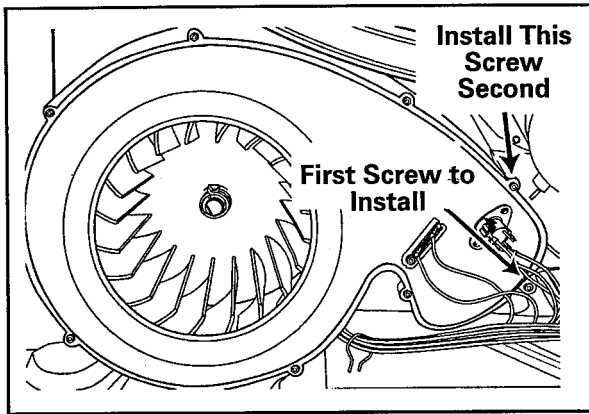

Figure 7-4

5. Install the screw for the blower cover tab to the base frame last.

Blower Wheel

The blower wheel is attached directly to the motor shaft behind the blower cover. Whenever replacing a blower wheel, always replace the clamp. (See Figure 7-5)

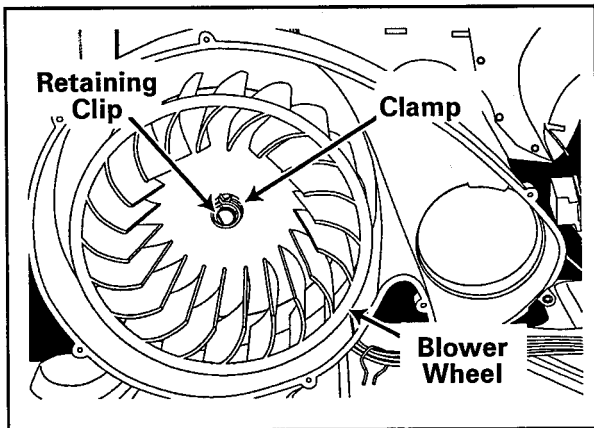

Figure 7-5

Removal

1. Disconnect power to the machine.
2. Remove front panel and close door.
3. Remove shroud/tumbler front assembly.
4. Remove blower cover.
5. Remove clip retaining ring.

6. Compress and remove clamp around hub of impeller.
7. Work blower wheel back and forth while pulling off shaft. It may require considerable effort to remove the blower wheel.

Exhaust Duct Pipe

One end of the exhaust duct pipe is held to the back of the cabinet by one screw. It fits over the blower housing on the opposite end. (See Figure 7-6)

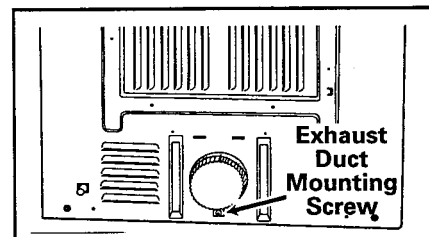

Figure 7-6

DRIVE MOTOR & IDLER ASSEMBLY

Motor Switch

A switching device in the motor is used to change the path of electricity from both start and run windings to run windings only. It also completes the circuit to the heat source when motor reaches proper speed. The external motor switch is secured to the motor with two screws.

1. Disconnect power to the machine.
2. Remove front panel and door.
3. Remove shroud/tumbler front assembly.
4. Remove belts.
5. Remove tumbler.

6. Remove wire harness from motor switch by depressing tabs on either side of the harness connector and lift the connector from the switch.
7. Remove two screws holding switch to drive motor.
8. Disengage the thermal protector switch from the motor switch body. This can be done by either inserting a small flat blade screwdriver into the slot near the switch terminals or breaking the switch body. The thermal protector switch is not replaceable and is part of the motor assembly.

Blower & Motor Assembly

The entire blower and drive motor assembly can be removed for servicing.

Removal of Assembly

1. **Disconnect power to the machine.**
2. Remove front panel and door.
3. Remove shroud/tumbler front assembly.
4. Remove the belt.
5. Disengage the idler pulley spring from the base.
6. Remove tumbler.
7. Remove the screw in front of the blower assembly that secures the assembly to the base frame.
8. Remove wire harness from drive motor and thermostats on blower cover.
9. Remove three screws securing motor to base frame. An extension is required to reach the screws. Screws are located directly behind the blower housing and the motor. *(See Figure 7-7)*

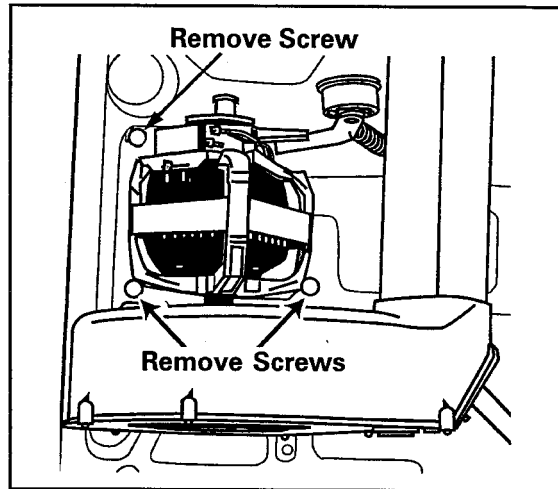

Figure 7-7

10. Carefully lift the front half of the blower assembly and slide the assembly forward to disengage the motor base rear tab from the slot in the base frame.

Assembly Breakdown

1. Remove blower cover screws.
2. Remove blower wheel.
3. Remove clip retaining ring clip from motor shaft, positioned behind the blower impeller.
4. Remove the motor support clips which retain the motor to the motor base. Use a nut driver large enough to accept the hook end of the clip. With a downward push of the driver onto the clip, tilt the driver handle toward the motor to unhook the clip from the support.
5. Remove motor from motor base.

Idler Arm Assembly

The motor turns clockwise as viewed from the front. The sleeve for the idler arm acts as a spacer so that the idler can float and aid in alignment of the belt. The idler arm spring maintains proper belt tension keeping it in alignment with the drive pulley.

Removal

1. Disconnect power to the machine.
2. Remove front panel and door.
3. Remove shroud/tumbler front assembly.
4. Remove belt and tumbler.
5. Unhook idler spring from the base frame and remove screw securing the assembly to motor support bracket.
(See Figure 7-8)

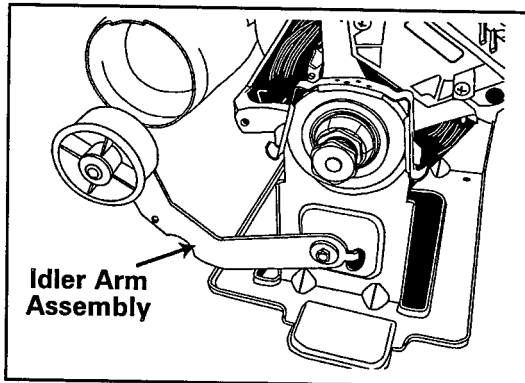

Figure 7-8

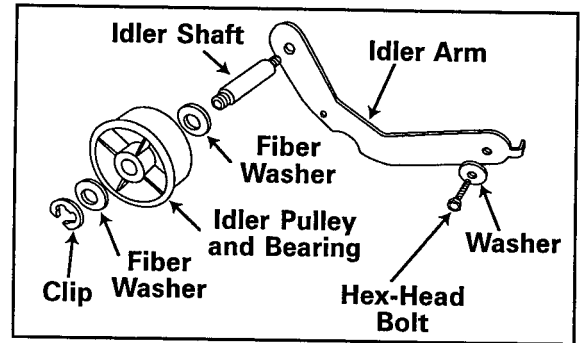

Figure 7-9

Disassembly

1. Remove retaining clip from groove in shaft.
2. Remove fiber washer.
3. Remove idler pulley and bearing.
4. Remove second fiber washer.

NOTE: *There is a fiber washer between the pulley and the idler arm. When replacing parts be certain the order of replacement is correct. (See Figure 7-9)*

IMPORTANT: *The position of the flange of the idler pulley is important. The flange should be positioned on the side opposite the idler arm.*

SECTION 8 - HEATING COMPONENTS

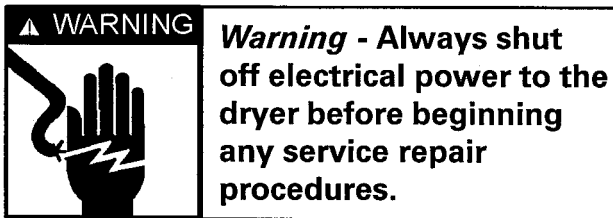

GAS VALVE ASSEMBLY

The gas controls utilize a hot surface ignition system. The three major components of the gas ignition system are: Igniter, Radiant Sensor and Gas Valve. (See Figure 8-1)

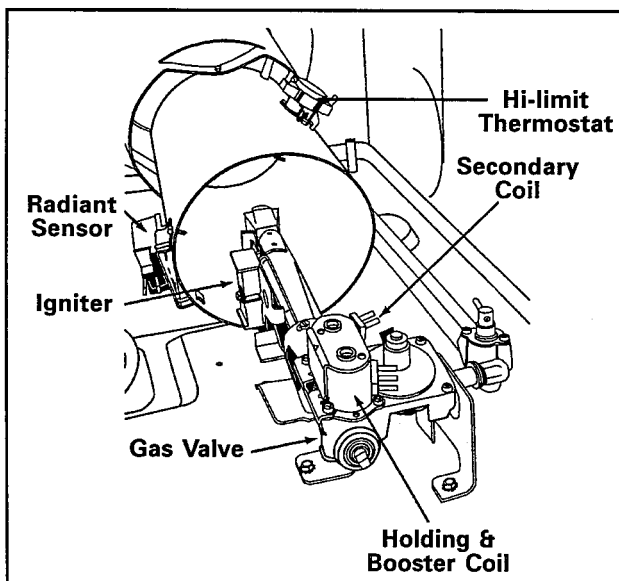

Figure 8-1

Igniter - When the controls call for heat, line voltage is applied to the igniter. This causes the igniter to heat up. It can reach a temperature of approximately 2200° F in about 30 seconds. Gas contacting the igniter at this temperature will ignite immediately.

Radiant Sensor - The radiant sensor operates much like a regular thermostat. It is mounted to the side of the combustion cone over an opening which exposes the sensor to the heat of the igniter and burner flame.

In its normal condition, the contacts in the radiant sensor are closed and the circuit is completed to the igniter. The heat from the glow of the igniter causes the radiant sensor contacts to open. This in turn, opens the current flow to the igniter and allows current to the secondary coil in the gas valve.

Gas Valve - The gas valve is actually two gas valves, one in series with the other. This is a safety feature providing added protection against gas released in the event of a failure of one of the valves to seat properly. (See Figure 8-2)

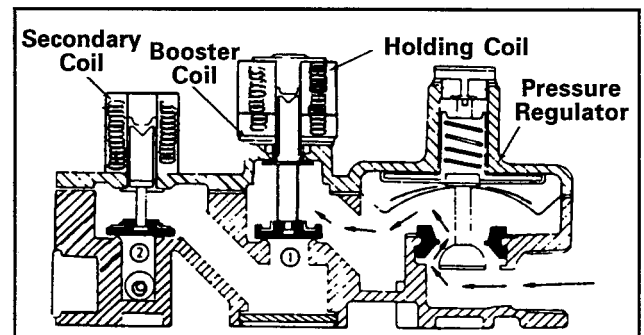

Figure 8-2

The first valve is opened by a solenoid which has two separate coils built into one solenoid. This solenoid uses what is termed a split coil. The coils are referred to as the **Holding Coil** and the **Booster Coil**.

Both coils are needed to lift the armature and open the valve. The holding coil is strong enough to keep the valve open once the armature has been lifted.

The second of the two valves is operated by the traditional one coil solenoid. This is called a **Secondary Coil**.

Phase 2: Radiant Sensor Contact Open:
The igniter is now hot and valve one (1) is open. The heat from the igniter causes the radiant sensor switch contacts to open.

With the radiant sensor contacts open, the secondary coil is no longer bypassed. The secondary coil is now in series with the parallel circuit combination of the booster coil and the igniter. (See Figure 8-5)

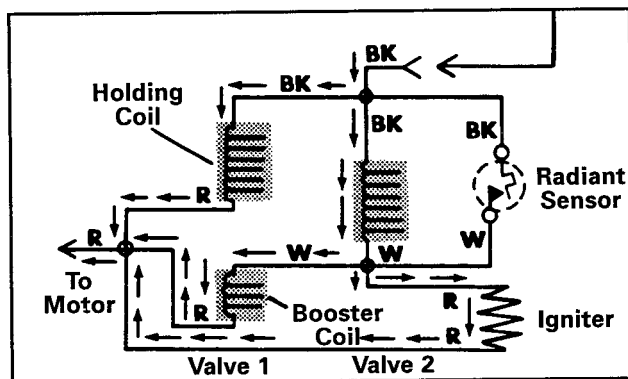

Figure 8-5

Because of the relatively low resistance of the hot igniter, most of the line voltage is dropped across the secondary coil. The remaining voltage is dropped across the booster coil and igniter. (See Figure 8-6)

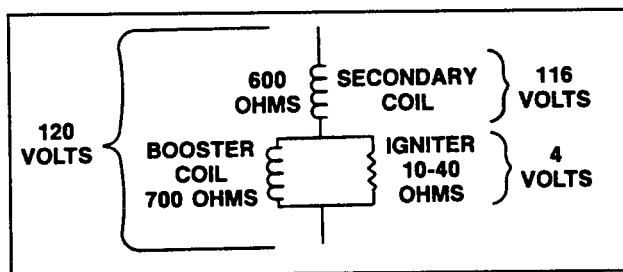

Figure 8-6

The secondary coil now opens the second valve releasing gas across the still extremely hot igniter. The gas ignites immediately and the burner flame is established.

NOTE: *Since the igniter will cool, the tip is positioned in the burner flame which keeps it hot and resistance low.*

The ignition cycle is now completed and the drying cycle begins.

Gas Conversions

The gas valve is set for use with natural gas when shipped from the factory. Because of differences in operating pressure and heat content of gases, the valve must be converted to use fuels other than natural gas.

Conversion kits are available to convert from natural to L.P. and back to natural. Check parts catalog for correct part number.

Safety Features

The design of the system provides for fail-safe operation in the event of power interruption, ignition failure, or flame failure as described below.

Power Interruptions

If the power to the burner assembly is cut off, either by opening the dryer door or by a power line failure, both valves in the gas valve assembly will close. Gas flow will cease.

When power is restored to the valve, the radiant sensor will start the process again. However, if the radiant sensor has not cooled and the contacts are still open, the secondary coil will receive full voltage and OPEN with no gas flowing through the secondary valve.

Since the secondary coil is in series with the booster coil, the reduced current flow through the booster coil is insufficient to create a strong enough magnetic field to help open the first coil valve. When the radiant sensor cools and closes its contacts, the sensor will shut the secondary coil again, providing a full current flow to the igniter and the booster coil, and system will go through a normal ignition sequence.

Ignition Failures

When the radiant sensor reacts to the heat from the igniter and the contacts open, the secondary coil energizes, opening the secondary valve. This allows gas to flow to the burner.

If no gas is present or the gas flow is not ignited, the radiant sensor will cool and the contacts will close, causing the secondary valve to close, thus allowing the igniter to reheat. The system will continue to cycle in this manner until normal ignition occurs or the dryer is turned OFF.

Flame Failure

If the burner flame should go out for any reason, the radiant sensor contacts will close in about 45 seconds and the gas system will go through a normal ignition sequence.

Air Shutter Adjustment

The air shutter has been stamped "LP" and "N" (for Natural): Loosen the screw holding the shutter, rotate the shutter until the end of the slot (labeled for the gas to be used) contacts the screw. Tighten the screw to lock the shutter in place. (See *Figure 8-7*)

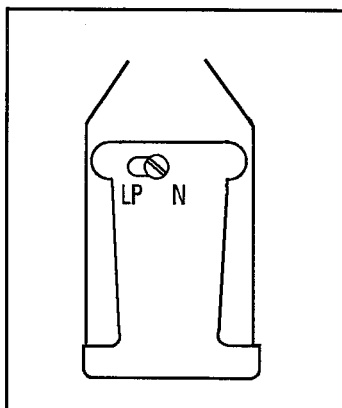

Figure 8-7

Gas Chart

Gas Type	Natural	L.P.
BTU Per Cu. Ft.	1075	2500
Pressure Inches	3.5	11
Specific Gravity	0.65	1.53
Drill Size	42	54

Coil Replacement

To replace the coils on this valve, disconnect electrical power supply. Remove the front panel, unplug the wire harness from the gas valve coils. Once the coils have been unplugged, remove the two screws that secure the coil holding bracket.

Remove the bracket and lift the coils off. (See *Figure 8-8*) Replace coils, bracket and wire harness.

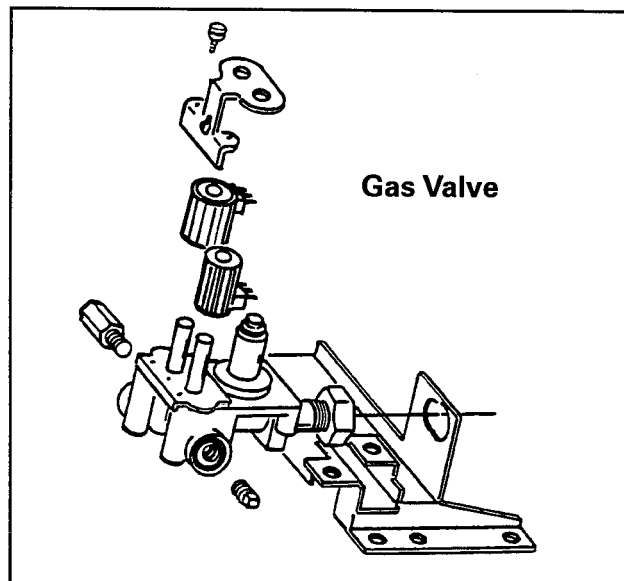

Figure 8-8

NOTE: When repositioning the coils onto the valve, align the coil positioning tabs and matching holes in the coil holding bracket for each coil.

Igniter

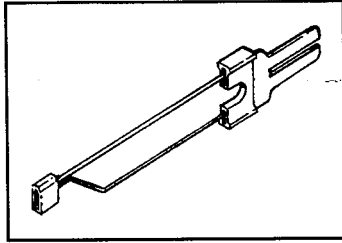

Figure 8-9

The igniter is used to ignite the gas as it comes from the gas valve. It is located on the left side of the burner (as viewed from the front of the dryer). The igniter is very fragile and must be handled carefully. Should you find a broken igniter, replace it. Operate dryer and see if igniter stays ON. If igniter stays ON longer than 40 seconds, replace radiant sensor.

1. **Disconnect power to the machine.**
2. Remove front panel and close the door.
3. Unplug igniter from gas valve.
4. Remove screw holding igniter to burner.

Gas Valve Removal

1. **Disconnect power to the machine.**
2. Remove front panel and close the door.
3. Shut off gas supply and disconnect supply line to valve.
4. Disconnect wire harness at valve coils.
5. Disconnect wires from radiant sensor.
6. Remove two screws holding valve and burner assembly to base.
7. Loosen brass nut attaching angle connector to gas valve.
8. Slide valve bracket out of slot in base and remove valve and burner assembly.

9. Remove two screws holding gas valve to bracket on underside.

Orifice Removal

Remove the burner assembly. The orifice can be removed with a 3/8" wrench.

Combustion Cone Removal

1. **Disconnect power to the machine.**
2. Remove front panel and close the door.
3. Remove burner and igniter. Be careful, igniter is fragile.
4. Remove wires from high limit thermostat.
5. Remove screw in front of cone holding it to base.
6. Remove screw at back of combustion cone holding cone tab to inlet duct.
7. Pull combustion cone out of dryer.

Inlet Duct

This duct serves to channel heated air into dryer tumbler. (See *Figure 8-10*)

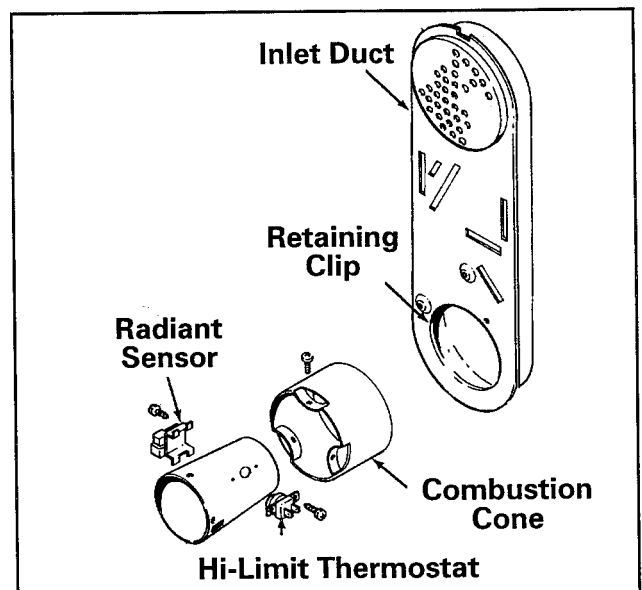

Figure 8-10

1. Disconnect power to the machine.
2. Remove front panel and the door.
3. Removal shroud/tumbler front assembly, tumbler and belt.
4. Remove screws securing heat cone to base and to inlet duct.
5. Remove tumbler back assembly.

NOTE: *Four screws are accessible from behind dryer.*

6. Remove three screws securing inlet duct to the tumbler back assembly. The two lower screws are under the felt seal of the tumbler back assembly.

NOTE: *For proper inlet duct to tumbler back assembly alignment when reinstalling, align inlet duct to large hole in the tumbler back assembly and fasten top screw first.*

HEATING ELEMENT & RELATED COMPONENTS

Heating Element

The heater on electric dryers is equipped with a heating element to provide approximately 5300 watts when operated on 240 volts. (See **Figure 8-11**) The element is divided into six segments on each side of a support plate. This design exposes the element to more airflow and results in a lower maximum coil temperature.

A terminal insulator is used on each end of the element which attaches to spade connectors. These spade connectors are "crimped" to the wire and held in the insulator by small barbs on each side of the terminal. The

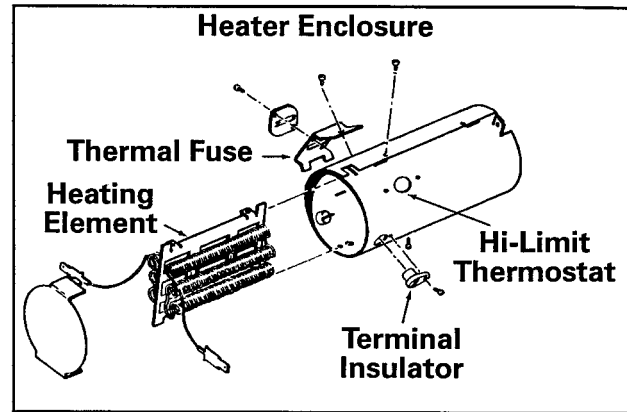

Figure 8-11

barbs must be bent parallel with each terminal before element package can be removed from the enclosure. Three screws hold the element package to the enclosure.

Heater Enclosure

1. Disconnect power to the machine.
2. Remove front panel and door.
3. Remove screw holding heater enclosure shield to base. Remove shield from dryer.
4. Remove screw in back of enclosure holding tab to inlet duct.
5. Remove wires from the thermal fuse and heater terminal on left side of enclosure. Remove purple wire from high-limit thermostat.
6. Pull heater assembly out of dryer.

SECTION 9. DRYER CONTROLS OVERVIEW

DRYER CONTROLS OVERVIEW

Models MDE/DG5500, and MDE/DG7500 are similar to the MDE/DG4000 dryer, with the exception being they have membrane switch and/or a touch screen versus console switches and a timer.

The key features of the LED Neptune Dryer:

- Membrane switch with LED display.
- Another dry cycle can be selected at any time during the dry cycle and the control will determine the completion of the cycle time.
- Control displays the estimated time remaining in the cycle for automatic sense dry cycles.
- The control stores codes to aid the service person in diagnostics.

The key features of the LCD Neptune Dryer:

- Membrane switch with LCD display and an analog touch screen.
- Another dry cycle can be selected at any time during the dry cycle and the control will determine the completion of the cycle time.
- The control will display the estimated time remaining in the cycle for automatic sense dry cycles. The control will display the true time remaining in the cycle for time dry cycles.
- The control stores codes to aid the service person in diagnostics.
- End of cycle signal adjustable.
- Dryel Cycle

BASIC CONTROL BOARD PHILOSOPHY FOR BOTH DRYERS

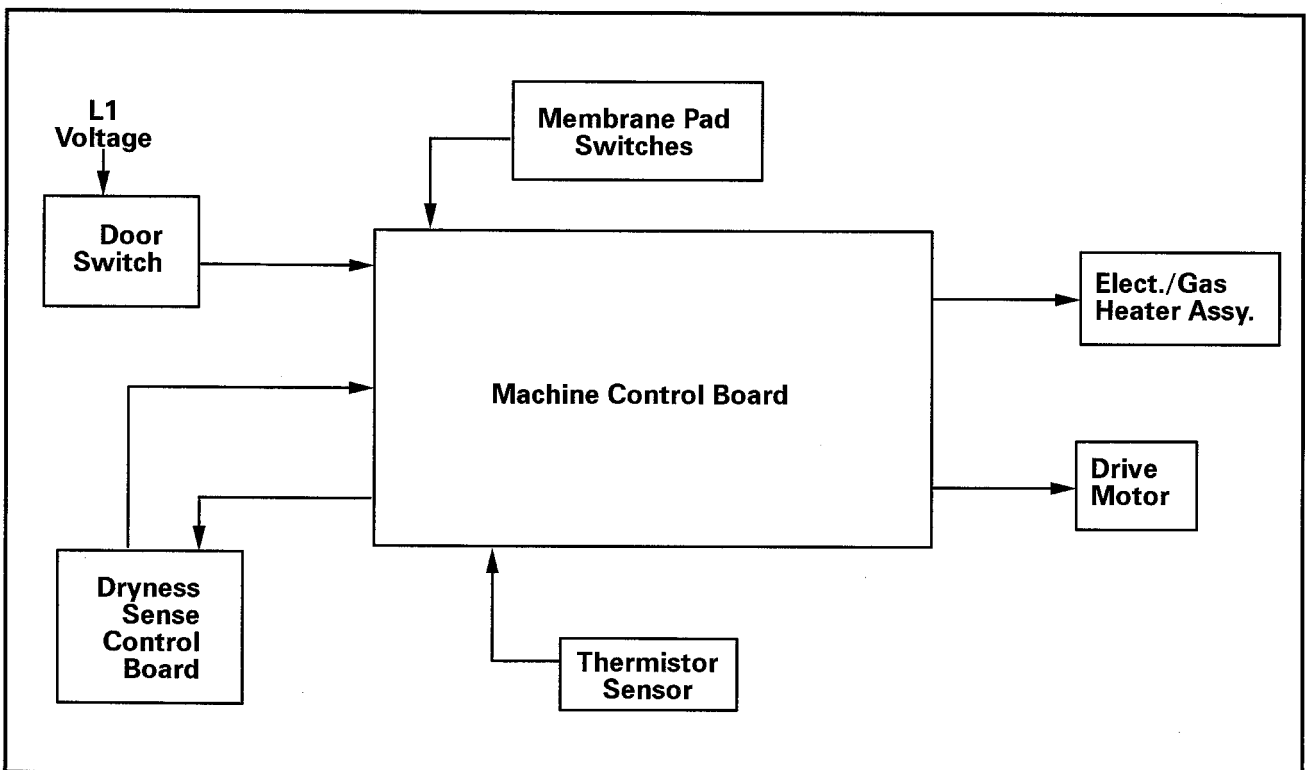

The machine control board monitors several inputs and outputs to operate the dryer. For example, the dryer monitors the ambient air in the laundry room to determine what the normal heat up time cycle is to determine if the dryer is operating properly and also counts the number of dry cycles performed.

Input	Purpose
Line Current	Power down detection
User Interface - switches	Keyboard
Dryness Sense	Impedance from Sensor Bar
Door switch input	Sense status of the door switch
Motor Transistor Sense	Sense conditions of 2 motor transistors on machine control board.
Thermistor	Temperature of the air stream
LCD Display	Displays the various interface screens.

Output	Purpose
Motor Relay	Energize relay to run dryer motor
Heater/Gas Relay	Energize relay to supply heat to dryer.
Dryness Sense Circuit #1	Enable Dryness Sense Circuit
Dryness Sense Circuit #2	Set Circuit Impedance for Damp & Less Dry Detection Levels.
Dryness Sense Circuit #3	Set Circuit Impedance for Normal, More and Very Dry Detection Levels.
Two digit, seven segment LED display	Show the estimate count down of the cycle.
LCD Display	Displays the various interface screens.

BASIC MACHINE OPERATION

The **MDE/DG5500 (LED)** dryer incorporates a membrane switch with multiple keypads, embedded LEDs and a 2 digit display readout display.

The **MDE/DG7500 (LCD)** dryer incorporates a transparent touch screen keypad located over the display with graphics to indicate key functions.

The control board function of both dryers, regulates dryer temperature, controls the dryer motor and logs diagnostic events. The control board receives feedback from temperature sensors, dryness sensors and status sensors within the dryer.

LED DRYER CONTROL SELECTIONS

The user can select the setting of several features while in the User Interface Active Mode or the Main Dry Cycle. The user sets the features by pressing a key on the keypad and the machine goes into the set mode. If the machine is in the main dry cycle, additional criteria may be applied prior to changing the feature. The modes to set a feature are:

- Select Cycle Type:
 - Sensor Dry
 - Time Dry
 - Wrinkle Release
 - Air Fluff
- Set Temperature
- Set Signal Mode
- Set Dryness Mode
- Set Options Mode

Sensor Dry

Provides a drying cycle that uses the sensor bars and a dryness control to control the length of the cycle. The cool down period is thermistor controlled to test the airstream for a temperature that is deemed acceptable for wrinkle reduction.

Time Dry

Provides a user selectable time period of heated drying followed by 5 minutes of cool down. The 5 minute cool down is included in the displayed time period on the control panel.

Time (+)(-)

Each keystroke will increment/decrement one minute up to 99 minutes. When changing the time for a "Time Dry" cycle, the "cool down" LED illuminates at the 5 minute point. Once the unit is in "Press Care" the time can not be adjusted. Opening the door or pausing the cycle, in Press Care will cancel the cycle.

Temp (^)(v)

Each actuation of the pad will increment/decrement one temperature level. These pads will NOT allow a continuous loop. The "up" pad takes the temperature to top. The "down" pad takes the temperature to the bottom. Wrinkle Release cycles always default to the highest temperature, but can be modified.

Dryness (^)(v)

Each actuation will increment/decrement one dryness level. Changing the dryness, does not allow a continuous loop. The (>) pad move to the damp dry setting. The (<) pad moves to the very dry setting.

Wrinkle Release

This key provides a cycle that will aid in removing wrinkles that have been set in the clothing. This is essentially a "timed" cycle that provides 8 minutes of heat followed by a 10 minute cool down. (Previously called Permanent Press).

Wrinkle Prevent Option

This provides an extended care portion for many cycles. The cycle is defined as: 95 minutes broken down as follows -- 20 minutes of continuous tumbling followed by intermittent tumbling (10 seconds of every 5 minute time period). Any time prior to initiation of the "press care" portion of the cycle (when the pad is active), the pad will function as an on/off toggle. Press Care is an available option for sensor dry, time dry and wrinkle release cycles. Signal: A signal is given: 1. At the end of the regular cycle 2. At the end of the 20 minute continuous tumble 3. At the end of each intermittent tumbling period.

Note: If the door is opened during the "press care" the cycle is cancelled. If the user leaves the unit "paused," follow the normal time-out procedure.

Air Fluff

When "Air Fluff" is selected: Sensor Dry and time dry LEDs are "off". Twenty (20) minutes appears in the display and the "time +/-" pads are active (time +/- LED is "on").

Note: *Wrinkle Prevent is NOT available as an option with this temperature setting. This is essentially a no heat timed dry cycle of x minutes.*

Start/Pause

This is the only pad capable of starting the dryer. If the "start" pad is pushed from the "sleep" mode, the dryer will immediately start using the settings from the previous run. If the pad is pushed while the drying is operating, the dryer will shut down and the control will "pause" (flashing the "start/pause" LED). This will suspend the cycle for four hours. If the cycle is paused (LED flashing), another actuation of the "start/pause" pad will restart the cycle at the point of interruption. If the cycle is paused by opening the door, the "start/pause" LED will flash. The control will power down to the "sleep" mode if the cycle is not re-initiated within four hours of the point the door was opened or after the machine has been placed into the idle mode. If the machine is idle for 10 minutes, the timer will time out.

Signal

Each actuation will increment/decrement one volume level. Full advancement will not provide a continuous loop. The (-) pad stops at "off" and the (+) pad stops at the highest volume level. The full advancement rate is 1 volume level per 0.5 seconds. An audible feedback is provided (at the appropriate volume) for each volume level. There is no audible feedback and the LED turns off at the "off" level. Pads that are Not applicable will be inoperative and provide no feedback.

Off

The "off" pad always functions to end the machine operation and put the control in the "sleep" mode.

SIGNAL MODES

The volume level of the end of cycle signal is adjustable. The sound ranges from "off" to "3" in increments of 1. The user will be able to select the plus (+) to increase the volume level. The user will be able to select the minus (-) to decrease the volume level. When the user first presses either of these keys, the current signal level will be demonstrated.

Subsequent presses of either the plus or minus button within 5 seconds of the previous key press will increase or decrease one level. The new signal level will sound.

This signal is used in the following manner:

- **End of Cycle:**
 - Sounds three long beeps at end of cycle.
- **Remind Chime:**
 - a) Press Care option – after 20 minute continuous tumble portion of press care, the signal is given, and then every 5 minutes after the intermittent tumble.
 - b) If the door has not been opened after the dry cycle, the signal is given every 5 minutes for 2 hours. (LCD dryer only)
- **Cool Down Signal:**
 - Sounds 3 short beeps upon entering the Cool Down cycle.
 - a) Time Dry cycle
 - b) Sensor Dry cycle
 - c) Wrinkle Release cycle
- **Dryel cycle (LCD models only)** – at the beginning of cool down and every minute until the end of the cycle.

DRYER TEMPERATURE CONTROL

There are two (2) thermostats in the dryer in addition to the thermistor. The thermistor is the control element used to cycle the heat for a normal cycle. There is also a 160°F cycling thermostat that is used for backup only on the blower housing.

In the event that the dryer control senses the temperatures (in the 160°F range) and cycles the heater or gas relay, it is likely that the control is cycling on the 160°F cycling thermostat. This would indicate that the thermistor control is not working.

The dryer also has a high limit thermostat that opens at 220°F on the gas models and at 220°F on the electric models.

The normal heater control function will perform the following tasks: check the temperature in dryer air stream (thermistor input) and control the heater depending on the temperature value read or the cycle requirements. The dryer will use the predetermined temperatures listed in the table below, to know when the heater is to be cycled on and off. These predetermined temperatures are selected by the consumer and may be cycle specific.

The values below are supplied only as an example of average resistance values seen by a number of thermistor controls tested.

LED Dryer

Note, when in the Service Mode and the dryer is running, the control will indicate the temperature reading found in the blower housing via the thermistor. The reading will be displayed in Celsius due to the 2-digit display.

LCD Dryer

When in the Service Mode and the dryer is running, the control will indicate the temperature reading found in the blower housing via the thermistor. The reading will be displayed in Fahrenheit.

Smart Cool Down Function

As the customer uses the dryer, the control board will "learn" about the type of ducting and the customer's habits to develop a more accurate cool down time for that dryer. To accomplish this, the thermistor is read at the end of each cycle to determine time to reach 100°F.

Ten cycle cool down times will be used to obtain an average of the time it takes the dryer to dry those cycles to the 100°F. This average time plus 1 standard deviation will then be used as a cool down time for all cycles.

The ten cycle average will be continually recalculated to adapt to changes in the ducting and the user's habits. Those locations where the ambient temperature is higher than normal, the above specified cool down temperature may not be attainable.

Dryer Sensor

The dryer provides a drying cycle that uses the sensor bars and a dryness sensor control board to control the length of the cycle. This selection provides an estimated time remaining in the cycle that is updated as the clothes reach the damp dry level and again at the normal dry levels.

Note: If there are no impedance or sensor readings in the first 3 minutes, the dry cycle will be terminated immediately.

Name	Temperature °F/°C	Cycles Off °F	Cycles On °F	Resistance (Ohms)
Regular	150/66	-15	15°F below heat	1860
Medium (factory default)	143/62	-15	15° below heat	2350
Delicate	135/57	-15	15° below heat	2700
Ultra Low	125/52	-10	10° below heat	3200
Air Fluff	Ambient			

SPECIAL FEATURES

The LCD and LED dryers come with several new features not available with the earlier versions of the Neptune dryers. By pressing a combination of keys, the dryer can be placed into an Advertising Mode or into a Service Mode for the service technician.

ADVERTISING MODE

This mode will continuously display the LEDs on the keyboard or illuminate the touch screen.

LED Dryer

Pressing the **damp dry** and **sensor dry** keys for 5 seconds will start the washer in the Advertising mode. No functions will be run except illuminating the LEDs.

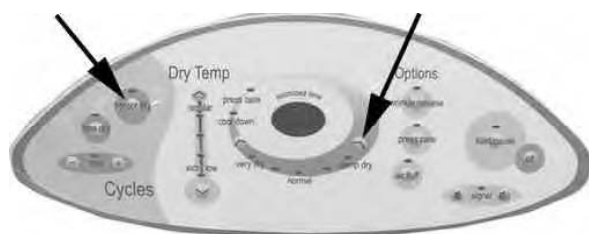

All the LEDs will light within 1.5 seconds in the following order and repeat: start/pause, signal, wrinkle prevent, wrinkle release, air fluff, damp dry, less dry, normal dry, more dry, very dry, cool down, wrinkle prevent indicator, temperatures (regular, medium, low, extra low), sensor dry, time dry, time(+), time(-), 7 segment display.

Enter and exit the advertising mode by using the same 2 key sequence or unplug the power cord.

LCD Dryer

This mode will continuously display the touch screen on the keyboard.

Pressing the **favorites** and **back** keys for 5 seconds will start the dryer in the Advertising mode. No functions will be run except illumination of the touch screen panel.



While in advertising mode, the display will cycle through eleven screens. If the touch screen or any key (except off) is pressed, the advertising sequence will be interrupted and the control will go to the Interactive State.

When this occurs, the user is able to navigate through the control as normal (including setting favorites, setting preferences, etc.), but the machine will not be allowed to run a cycle. The only methods of exiting the advertising mode is to remove power from the machine or to press and hold both the **help** key and the **favorites** key for 5 seconds. The off key will not be active in the service mode.

After 5 minutes of inactivity in the advertising mode, the control will time out and return to advertising mode and the advertising sequence will begin again. When the control times out in this manner, any settings or changes that the user had made while in the advertising mode will not be remembered.

SERVICE /DIAGNOSTIC MODE

This mode provides service personnel the ability to verify the operation of the dryer.

The service mode can be implemented in the middle of any dry cycle. While in the service mode, the servicer can start special service tests such as a system check mode, membrane pad check, display software revision number and display diagnostic/help code listings. (See Service Mode Table) The diagnostic/help code information displayed provides information about the machine.

To aid the service technician, special software was incorporated into the control boards of the MDE/DG5500 & MDE/DG7500 dryers. The software is used to monitor several functions of the dryer during operation and identify any abnormalities as they arise. These abnormalities can be monitored in the Service Mode and the board will list previously identified failures as either a Help or a Diagnostic code.

The Diagnostic codes are identified when the severity level of the abnormality detected is higher and service may be required.

Both code lists are stored in separate permanent memories with a maximum of nine codes per list.

NOTE: *Due to the various differences in the two dryer control systems, the following pages will focus first on the LED dryer then the LCD dryer.*

Press Keys	Special Test/ Function
wrinkle release	Diagnostic Codes
dryer temp(^)	Sequences up the help/diagnostic code list
dryer temp(v)	Sequences down the help/diagnostic code list
time (-)	Displays Software Revision Number
very dry(<)	View current cycle temperature (C°)
start/pause	Start or pause cycle running but remain in Diagnostic mode

LED DRYER

Accessing Service/Diagnostic Mode:

Pressing down the **damp dry** and **time (-)** keys for 5 seconds places the machine in the diagnostic mode.

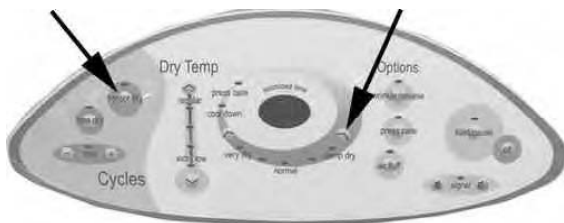

SPECIAL TESTS

The following table lists the various tests available while in the Service Mode, which can be accessed by pressing the following keys:

Diagnostic Codes:

When a problem with the dry system is detected a diagnostic code is assigned and logged into the control board memory. An assigned diagnostic code indicates the dryer may need to be serviced. The control board will not log multiple same codes per cycle, however, it will log as many diagnostics as possible for the machine to continue running.

See the diagnostic code table for specific actions or references to where the proper action is defined. (See page 15)

Accessing Diagnostic Codes

After the machine is in the diagnostic mode, a 'd' will display and let the technician know they are in the diagnostic mode. Pressing the **wrinkle release** key will access the diagnostic codes. The diagnostic codes can be viewed by using the temperature (^) & (v) keys.

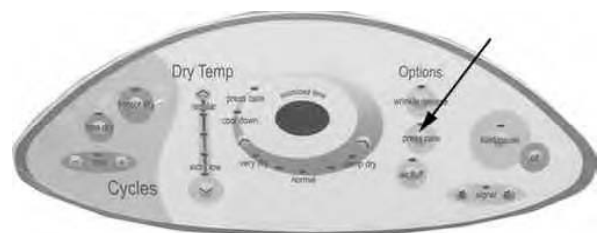

The down arrow key will sequence down the list one each time it is pushed with no wrap. The first time the down arrow key is pushed the display will sequence to the next code logged. The last code being displayed being the oldest code. The up arrow will sequence up the list one code each time it is pushed until it reaches the top code. If there are no diagnostic codes available, '00' will be displayed for the diagnostic code.

There will be no multiple occurrences of either a diagnostic code or help code generated in the same cycle reported on the list. But if the same code occurs in repeated cycles, it will be registered.

To **clear the diagnostic code list** press **wrinkle prevent** and **very dry (>)** for 5 seconds while viewing the list.

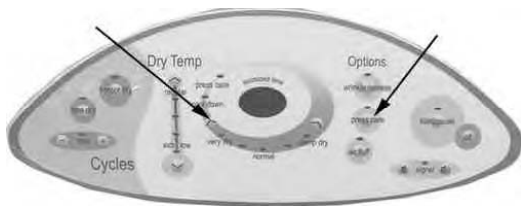

System Check Mode

While in diagnostic mode, pressing the **damp dry** and **signal (+)** keys for 2 seconds, will put the dryer into the system check mode. "SC" will display.

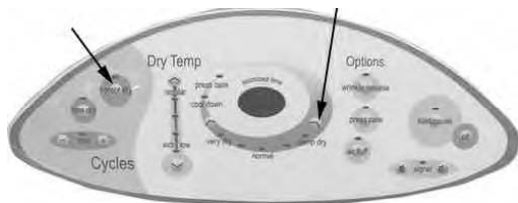

This mode will allow the various inputs and outputs to be controlled and viewed by the technician by pressing individual keys. If no activity is seen for 5 minutes after a key is depressed, the control will reset back to the normal mode. If no further activity is seen after an additional 5 minutes the washer will turn off. The following table lists the various functions based upon on keys being depressed.

Key Pressed:	Function Performed
sensor dry	Enable sensor dry circuit. (sense dry LED) When short circuit is detected across the sensor bars the normal dry LED will turn on.
start/pause	Cycles the motor relay on/off. When the motor is running the start/pause LED is on.
dry temp(^)	If motor is running, cycles the heater/gas valve on/off. When the heater is regular temp LED is on.
very dry(<)	View current cycle temperature (C°)

Membrane Pad Check

While in system check mode, pressing the **damp dry** and **sensor dry** keys for 5 seconds, will start a membrane pad switch test.

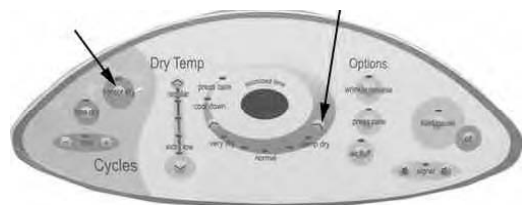

The membrane check involves turning all the embedded LED on the membrane pad on. All the LED's can be toggled off by pressing the key associated with the LED. To exit the test at any point, press the damp dry (>) & sensor dry keys again for 5 seconds or press the off key to exit diagnostic mode.

LCD DRYER

Accessing Service Mode

Press and hold the **back** and **help** keys for 5 seconds to start the Service Mode.



Pressing the Service Mode keys again, will take the machine out of the Service Mode.

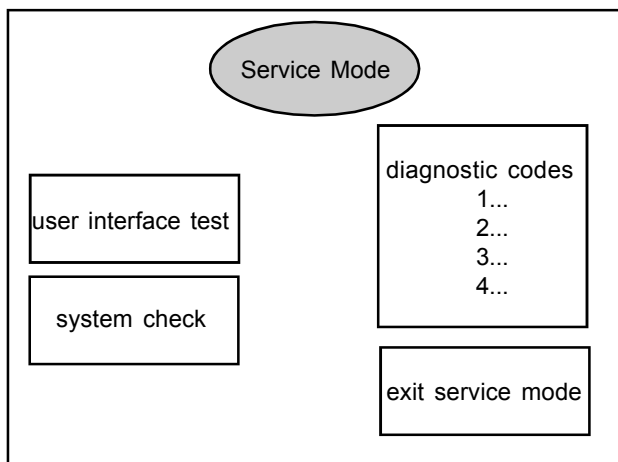

The Service Mode screen lists four different touch panels; user interface test (membrane switch test), system check, diagnostic codes and exit service mode. Pressing any of the touch screens will activate a different screen dedicated to that function.

The diagnostic codes listed are the last four codes assigned by the dryer.

After 5 minutes of inactivity in Service Mode, the dryer will exit Service Mode and return to the state just prior to Service Mode. If a service test is being run, the control will remain in Service Mode until 5 minutes of inactivity has occurred at the end of this cycle.

User Interface Test:

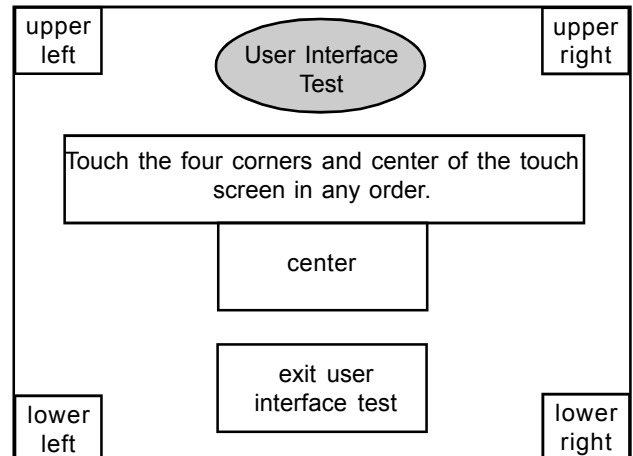

This will check the touch screen. The service technician is prompted to "Touch the four corners and center of the touch screen in any order." When each area is pressed, the display will reverse image. If all areas are sensed, the control will display "Touch screen test passed." If any area(s) is not sensed within 5 seconds, the technician will be prompted to "Touch the area(s) not highlighted." If the area can still not be sensed within 5 seconds, the control will display "Touch screen test failed." In either case scenario, the screen will step to the next screen to check the membrane switches.

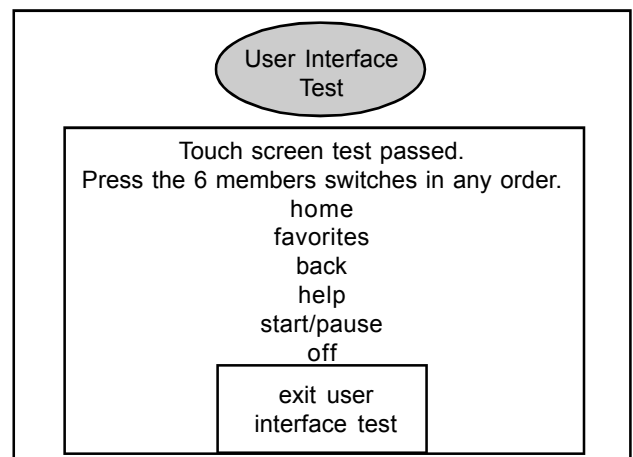

This test checks the membrane switches on the console pad.

The screen displays the status of the touch screen test that was just performed. The

technician is then prompted to "Press the 6 membrane switches in any order." When each key is pressed, it will display in reverse image and remain that way. If all keys are sensed, the control will display "Membrane switch test passed." If any key (s) is not sensed within 5 seconds, the technician will be prompted to "Touch the key(s) that are not highlighted." If key(s) again are not sensed within 5 seconds, the control will display which key(s) failed.

The last step of the user interface test is to display the entire screen in reverse image for 2 seconds and then resume normal display mode. This is done as soon as the membrane switch test is complete. This is a visual test only.

SYSTEM CHECK

System checks can be run when the dryer is running a dry cycle or not. If the dryer is **not** in a dry cycle, the following screen will display and allow the technician to toggle various components On/Off.

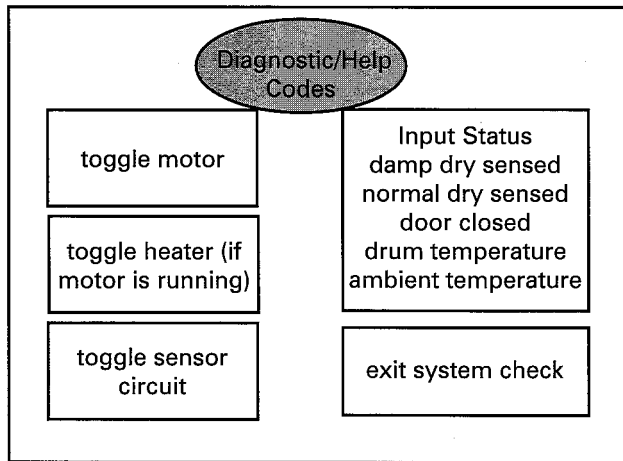

At the same time, the screen will display the current status of the component inputs to the control board.

If the dryer is already running a cycle and the system check is activated, then the screen will display the status of all the outputs and inputs to the control board.

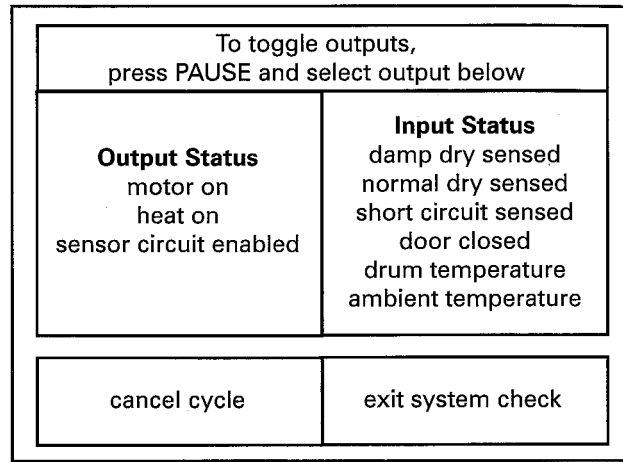

Cancel cycle: This will stop the current cycle.

Exit system check: This will exit the system check screen and revert back to the previous screen shown on the display panel.

DIAGNOSTIC/HELP CODES

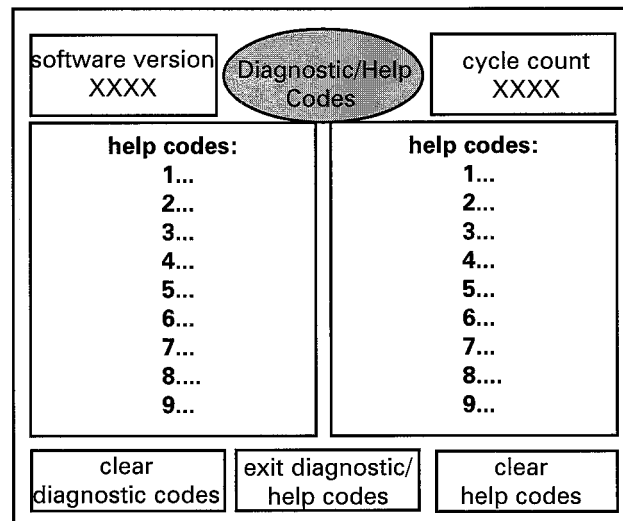

Diagnostic codes: Display all diagnostic codes and how many cycles ago the codes occurred.

Help codes: Display all help codes and how many cycles ago the codes occurred.

Cycle count: Display the cycle count.

Exit diagnostic/help codes: Clear diagnostic codes: Clear the entire list of diagnostic codes.
Software version: Display current software version

For a listing of available diagnostic codes see below:

DIAGNOSTIC CODE TABLE

Code	Description	Trigger	Action To BeTaken
01	Thermistor Short Sensed	If temperature > 200 degrees for 2 minutes.	<u>Check for:</u> - Clogged lint screen. - Restricted vent system. - Failed thermistor.
02	Thermistor Open Sensed	If the temperature is low and we are calling for increase in temperature and we see that there is no increase in the temperature occurring in 3 minutes.	<u>Check for:</u> - Low ambient temperature in room (Below 50°F/10°C). - Outside vent damper is stuck open in Winter time. - Loose or open wire terminals.
03	Door Circuit Failure	Low for more than 1 second.	<u>Check for:</u> - Loose or open wire terminals in Door Sense circuit.
04	Possible motor transistor error	If either motor transistor is seen open or shorted during startup:	<u>Check for:</u> - Loose connections in motor circuit. - Run System Check Mode and check the motor relay function. -- If relay functions, disregard the diagnostic code. -- If relay does not function, replace machine control board.
08	Stuck Key	A key is sensed to be pressed more than 75 seconds, the key shall be assumed to be stuck and will blink to indicate the location of the stuck key.	<u>Check for:</u> - Run membrane pad check and replace console w/membrane pad if necessary.

DRYER CONTROLS MDE/MDG6800, MDG5500

Control Configuration

This Trouble Shooting guide illustrates how the software works with the 13 and 15 key membrane switches. The section on Accessing Diagnostic Codes includes instruction for use with older control boards.

13 Key Membrane



15 Key Membrane

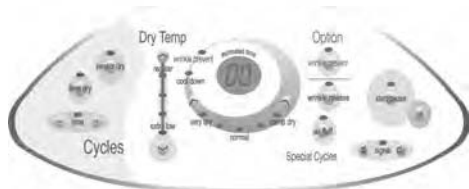

Service Mode

This mode provides Service Personnel the ability to verify the operation of the dryer.

The Service Mode can be implemented in the middle of any dry cycle. While in the Service Mode, the Technician can start special diagnostic tests such as a System Check Mode, Membrane Pad Check, Display Software version number and display diagnostic/help code listings.

Enter Service Mode:

Press **Air Fluff** and **Time (^)** - 13 Key Membrane.
or

Air Fluff and **Time (+)** - 15 Key Membrane.
keys for 3 seconds, or until a beep is heard. The machine will now be in Service Mode and "d" will be displayed.

Exit Service Mode

Press the **OFF** key to exit Service Mode or repeat the **Air Fluff** and **Time (+)** sequence.

Diagnostic Tests

The following table lists the various tests available while in the Service Mode, which can be accessed by pressing the following keys:

Key Press	Special Test/Function
Wrinkle release Then press Temperature (^) - 13 Key or Dry Temp (^) - 15 Key	Display list of diagnostic codes. To sequence thru the diagnostic and help codes.
Time (v) - 13 Key or Time (-) - 15 Key	Display revision number
Sensor Dry Level (^) - 13 Key or Very Dry (<) - 15 Key	View current cycle temperature in Celsius

Key Press	Special Test/Function
Start/Pause	Start or pause cycle running but remain in diagnostic mode.

System Check Mode

While in Service Mode, pressing the

Air Fluff and **Signal (+)** - 13 Key Membrane
or

Air Fluff and **Signal (+)** - 15 Key Membrane
keys for 3 seconds, will put the dryer into the System Check mode and "SC" will display. The following table lists the various functions based on the keys being pressed.

System Check Mode Table

Key Pressed:	Function Performed
Sensor Dry	Enable sensor dry circuit (sense dry LED) when short circuit is detected across the sensor bars the normal dry LED will turn on.
Start/Pause	Cycles the motor relay on/off. When the motor is running the start/pause LED is on.
Temperature (^) - 13 Key or Dry Temp (^) - 15 Key	If motor is running, cycles the heater/gas valve on/off. When the heater is regular temp LED is on.
Sensor Dry Level (^) - 13 Key or Very Dry (<) - 15 Key	View current cycle temperature in Celsius.

Membrane Pad Check

The membrane check turns all the embedded LED's on. All the LED's can then be toggled off by pressing the key associated with the LED.

While in **System Check Mode**, pressing the

Air Fluff and **Sensor Dry** - 13 Key
or
Air Fluff and **Sensor Dry** - 15 Key

keys for 2 seconds, will start a Membrane Pad Switch Test. To exit the test at any point, press the same keys again for 2 seconds or press the **OFF** key to exit Service Mode.

MDE/MDG6800, MDG5500

Diagnostic Codes

The Diagnostic Codes are identified when the severity level of the abnormality detected is higher and service may be required.

When a problem with the dryer is detected a Diagnostic Code is assigned, and can be displayed. The Control Board will not log multiple same codes per cycle; however, it will log as many Diagnostics as possible for the machine to continue running.

Accessing Diagnostic Codes with 13 Key Membrane

Press **Air Fluff** and **Time (^)** to enter Service Mode. Press the **Wrinkle Release** key to access the Diagnostic Codes. Scroll through the Diagnostic Codes by pressing the **Temperature (^)** key. The first time the key is pressed the newest code will be displayed. Each additional key press shows the next code. Once all the codes have been displayed a "d" is displayed and the process repeats. If there are no Diagnostic Codes available, "00" will be displayed for the Diagnostic Code.

Accessing Diagnostic Codes with 15 Key Membrane

Press **Air Fluff** and **Time (+)** to enter Service Mode. Press the **Wrinkle Release** key to access the Diagnostic Codes. Scroll through the Diagnostic Codes by pressing the **Temperature (^)**. The first time the key is pressed the newest code will be displayed. Each additional key press shows the next code. Once all the codes have been displayed a "d" is displayed and the process repeats. If there are no Diagnostic Codes available, "00" will be displayed for the Diagnostic Code.

There will be no multiple occurrences of either a diagnostic code or help code generated in the same cycle reported on the list. But if the same code occurs in repeated cycles, it will be registered.

Clearing Diagnostic Codes

To clear the diagnostic code list press

Air Fluff and **Wrinkle Release** - 13 Key
or

Air Fluff and **Wrinkle Release** - 15 Key
for 3 seconds while in diagnostic mode.

Diagnostic Codes

Code	Description	Trigger	Action Taken
1	Dryer Thermistor Short Sensed	The thermistor resistance is very low, with a temperature > 175 degrees.	<u>Check for:</u> - Clogged lint screen. - Restricted vent system. Failed thermistor.

Code	Description	Trigger	Action Taken
2	Thermistor Open Sensed	The thermistor resistance is very high	<u>Check for:</u> - Low ambient temperature in room (Below 50oF/10oC). - Outside vent damper is stuck open in wintertime. Loose or open wire terminals
3	Door Circuit Failure	Invalid state for more than 256 milliseconds	<u>Check for:</u> - Loose or open wire terminals in Door Sense circuit.
4	Possible motor transistor error	If either motor transistor is seen open or shorted during startup	<u>Check for:</u> - Loose connections in motor circuit. - Run System Check Mode and check the motor relay function. - If relay functions, disregard the diagnostic code. If relay does not function, replace machine control board.
5	Not Used		
6	Non Volatile Memory	Problem Detected with integrity of parameters stored in EEPROM memory.	Disregard
8	Stuck Key	A key is sensed to be pressed more than 75 seconds, the key shall be assumed to be stuck.	Run membrane pad check and replace console w/membrane pad if necessary.

MDE/MDG6800, MDG5500

Membrane Pad Continuity Checks

Note: Unplug connector and touch probe of meter to the appropriate pin numbers. Meter will show infinity on open keys and continuity on closed keys.

Membrane Pad	Pin Number	Pin Number
Sensor dry	J7(12)	J7(13)
Time dry	J7(11)	J7(13)
Time(^) 13 Key Time(+) 15 Key	J7(10)	J7(13)
Time(v) 13 Key Time(-) 15 Key	J7(9)	J7(13)
Temperature (^) 13 Key Dry Temp(^) 15 Key	J7(11)	J7(14)
Dry Temp (v) 15 Key	J7(10)	J7(14)
Sensor Dry Level 13 Key Very Dry (<) 15 Key	J7(12)	J7(14)
Damp Dry (>) 15 Key	J7(19)	J7(14)
Wrinkle Release	J7(11)	J7(15)
Wrinkle Prevent	J7(9)	J7(15)
Air Fluff	J7(10)	J7(15)
Start/Pause	J7(11)	J7(16)
Signal(v) 13 Key Signal(-) 15 Key	J7(12)	J7(15)
Off	J7(9)	J7(16)
Signal(^) 13 Key Signal(+) 15 Key	J7(12)	J7(16)

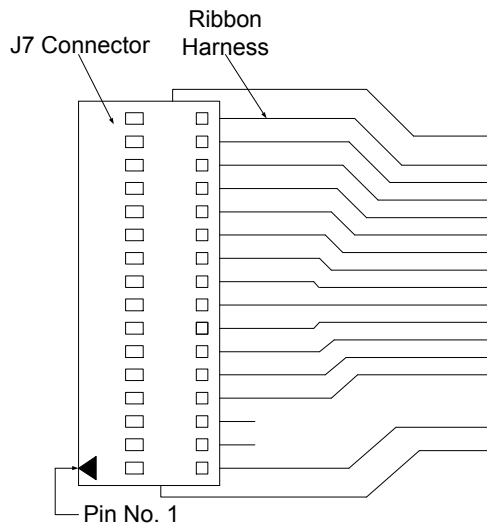
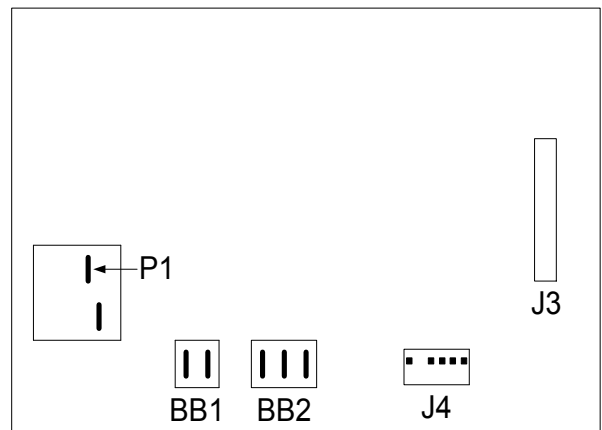

Description	Connector Pin Num	Connector Pin Num	Voltage	Comments
Heater Relay Internal Output	P1	BB1(1)	120VAC	
LI Board (input)	BB1(1)	BB2(3)	120VAC	Door must be closed.
Motor (input)	BB1(2)	BB2(3)	120VAC	Door must be closed
Neutral (input)	BB2(2)	BB1(1)	120VAC	
Door Sense	BB2(3)	BB1(1)	120VAC	Door must be open
Thermistor	J4(1)	J4(2)	5VDC	NTC 70 F = 10K ohms 150 F = 1754 ohms
Sensor Bar	J4(3)	J4(4)	24VDC	

MDE/MDG7500, MDE/MDG9800

Service Mode

This mode provides Service Personnel the ability to verify the operation of the dryer.

The Service Mode can be implemented in the middle of any dry cycle. While in the Service Mode, the Technician can start special diagnostic tests such as a System Check Mode, Membrane Pad Check, Display Software version number and display diagnostic/help code listings.

Removing A Favorite Cycle

If the consumer wants a favorite cycle removed, see below:

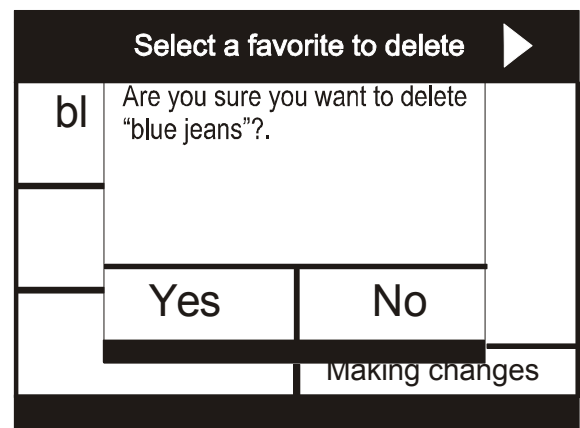
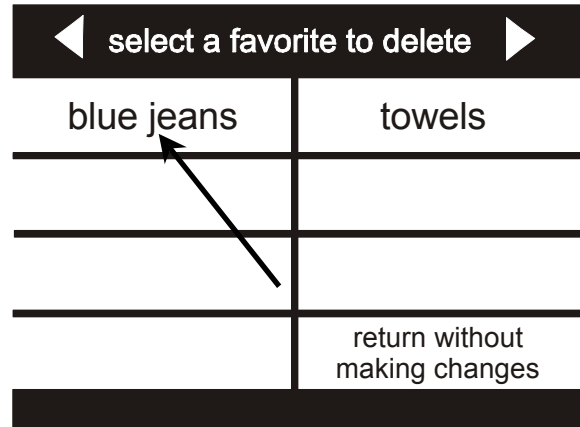
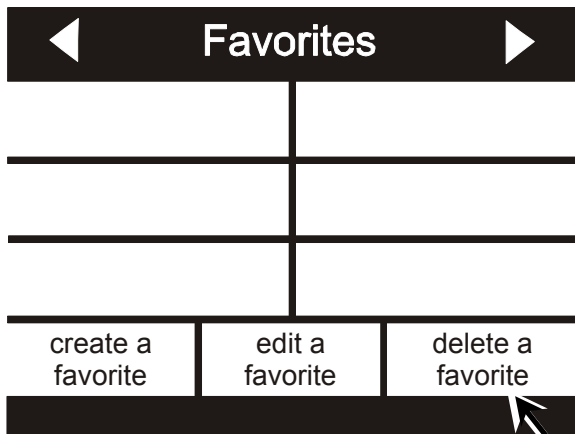
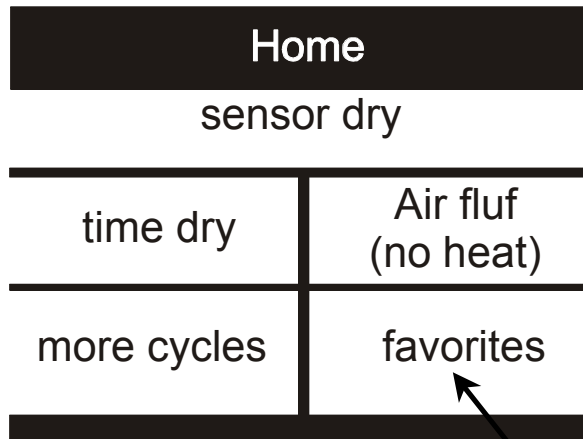

Enter Service Mode:

Press **Help** and **Back** Keys for 3 seconds or until a beep is heard.

Exit Service Mode

Press the **OFF** key or Exit Service Mode on the display exit Service Mode. After 5 minutes of inactivity in Service Mode, the machine will exit Service Mode and return to the state just prior to where the user first entered Service Mode.

MDE/MDG7500, MDE/MDG9800

User Interface

Enter User Interface and follow the directions on screen. This test will check the Membrane Pads and Touch Screen. The Membrane Pad and Touch Screen Test must be completed in approximately 10 seconds or a failure will be shown on the display.

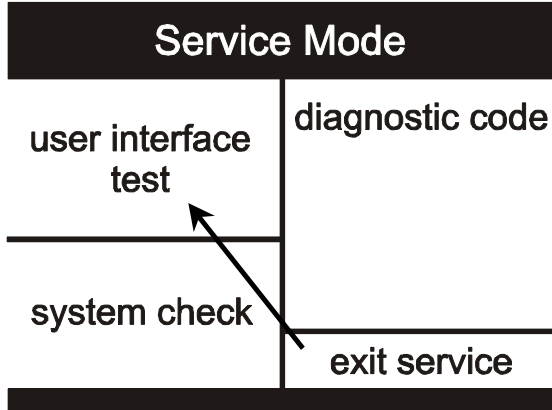

Membrane Pad Test

After passing the Touch Screen Test a Membrane Test will be performed.

This will check the Membrane Switch and display the status of the Touch Screen Test that was just performed. The user will be prompted to press the following 5 membrane switches in any order" (i.e. **home**, **favorites**, **back**, **help** and **start/pause**). The sixth key (i.e. **off**) should not be pressed. Pressing the **off** key will shut down the machine. If all keys are pressed, "Membrane switch test passed" will be displayed. If any key(s) are not pressed within 5 seconds, the user will be prompted to "Touch the key(s) that are not highlighted". If key(s) again are not pressed within 5 seconds, the display will show which key(s) failed.

System Check Cycle Not Running

System checks can be performed whether the dryer is in a dry cycle or not. If the dryer **is not** in a dry cycle, the display screen will allow the technician to toggle various components On/Off. The screen will also display the current status of the component inputs to the control board.

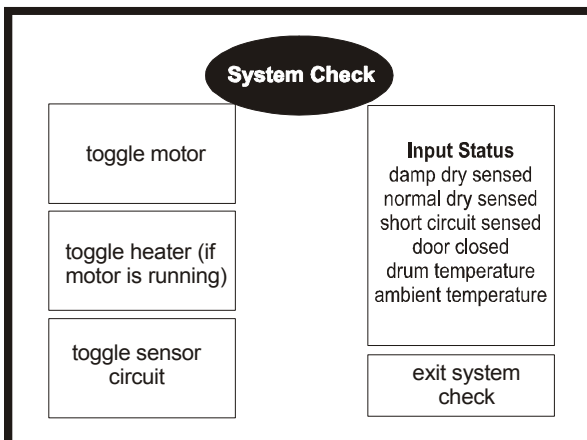

System Check Cycle Running

If the dryer is already running a cycle and the system check is activated, then the screen will display the status of all the outputs and inputs to the control board.

cancel cycle: This will stop the current cycle.

exit system check: This will exit the system check screen and revert back to the previous screen shown on the display panel.

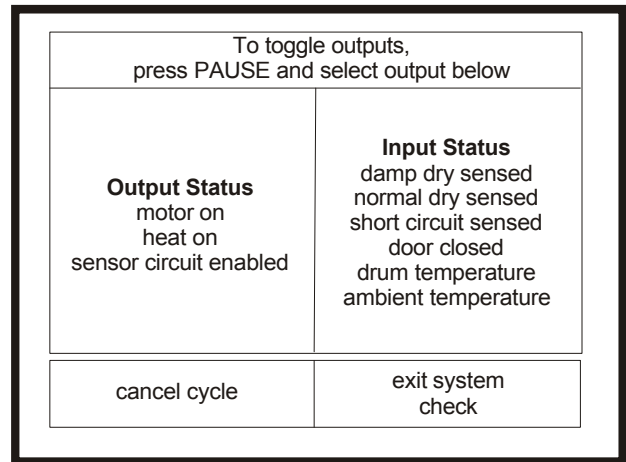

Diagnostic/Help Codes

Displays all the diagnostic codes and how many cycles ago the codes occurred.

Displays all the help codes and how many cycles ago the codes occurred.

Displays the current software version.

Displays the cycle count.

Enter Service Mode by Pressing **Help** and **Back** Keys for 3 seconds or until a beep is heard.

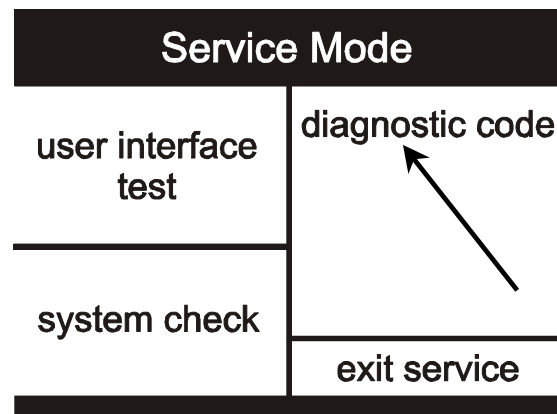

MDE/MDG7500, MDE/MDG9800

software version xxxx	Diagnostic/Help Codes	cycle count xxxx
diagnostic codes 1... 2... 3... 4... 5... 6... 7... 8... 9...	help codes 1... 2... 3... 4... 5... 6... 7... 8... 9...	
clear diagnostic codes	exit diagnostic/ help codes	clear help codes

Code	Description	Trigger	Action Taken
8	Stuck Key	A key is sensed to be pressed more than 75 seconds, the key shall be assumed to be stuck.	Run membrane pad check and replace console w/membrane pad if necessary.

Membrane Pad Continuity Checks

Note: Unplug connector and touch probe of meter to the appropriate pin numbers. Meter will show infinity on open keys and continuity on closed keys.

Membrane Pad	Pin Number	Pin Number
Home	J7(3)	J7(5)
Favorites	J7(4)	J7(5)
Back	J7(3)	J7(6)
Start/Pause	J7(4)	J7(7)
Off	J7(3)	J7(7)
Help	J7(4)	J7(6)

Diagnostic Codes

Code	Description	Trigger	Action Taken
1	Dryer Thermistor Short Sensed	The thermistor resistance is very low, with a temperature > 175 degrees.	Check for: <ul style="list-style-type: none"> - Clogged lint screen. - Restricted vent system. Failed thermistor.
2	Thermistor Open Sensed	The thermistor resistance is very high	Check for: <ul style="list-style-type: none"> - Low ambient temperature in room (Below 50oF/10oC). - Outside vent damper is stuck open in wintertime. Loose or open wire terminals
3	Door Circuit Failure	Invalid state for more than 256 milliseconds	Check for: <ul style="list-style-type: none"> - Loose or open wire terminals in Door Sense circuit.
4	Possible motor transistor error	If either motor transistor is seen open or shorted during startup	Check for: <ul style="list-style-type: none"> - Loose connections in motor circuit. - Run System Check Mode and check the motor relay function. - If relay functions, disregard the diagnostic code. If relay does not function, replace machine control board.
5	Not Used		
6	Non Volatile Memory	Problem Detected with integrity of parameters stored in EEPROM memory.	Disregard

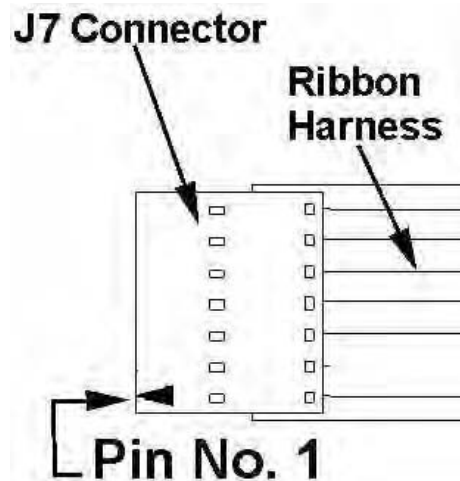

MDE/MDG7500, MDE/MDG9800

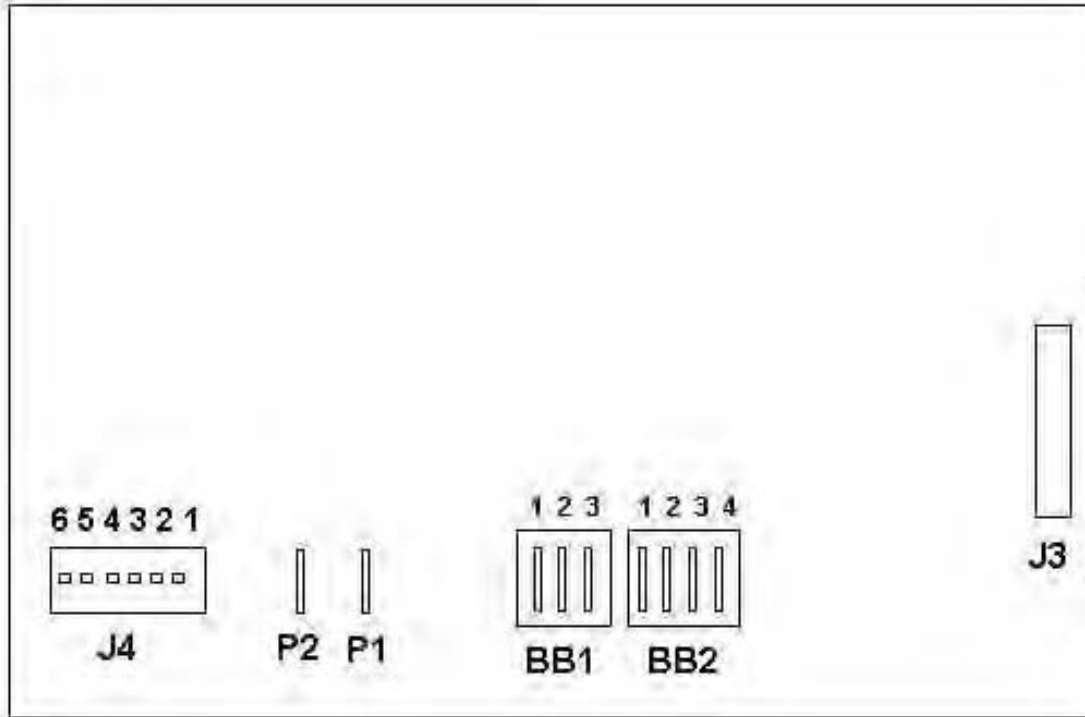

Description	Connector Pin Num	Connector Pin Num	Voltage	Comments
Heater Relay Internal Output	P1	BB1(1)	120VAC	
LI Board (input)	BB1(1)	BB2(3)	120VAC	Door must be closed.
Motor (input)	BB1(2)	BB2(3)	120VAC	Door must be closed
Neutral (input)	BB2(2)	BB1(1)	120VAC	
Door Sense	BB2(3)	BB1(1)	120VAC	Door must be open
Thermistor	J4(1)	J4(2)	5VDC	NTC 70 F = 10K ohms 150 F = 1754 ohms
Sensor Bar	J4(3)	J4(4)	24VDC	

SECTION 10 - WIRING DIAGRAMS

MDE3000

CIRCUIT	FUNCTION	REG. FABRICS		TIME DRY		PERMANENT PRESS	
		OFF	ON	OFF	ON	OFF	ON
①	GY-PK CHIME						
	YL-GY DRIVE MOTOR						
②	YL-OR ELECTRONIC CONTROL						
③	BK-BU HEATER						
④	BK-PU PRESS CARE						

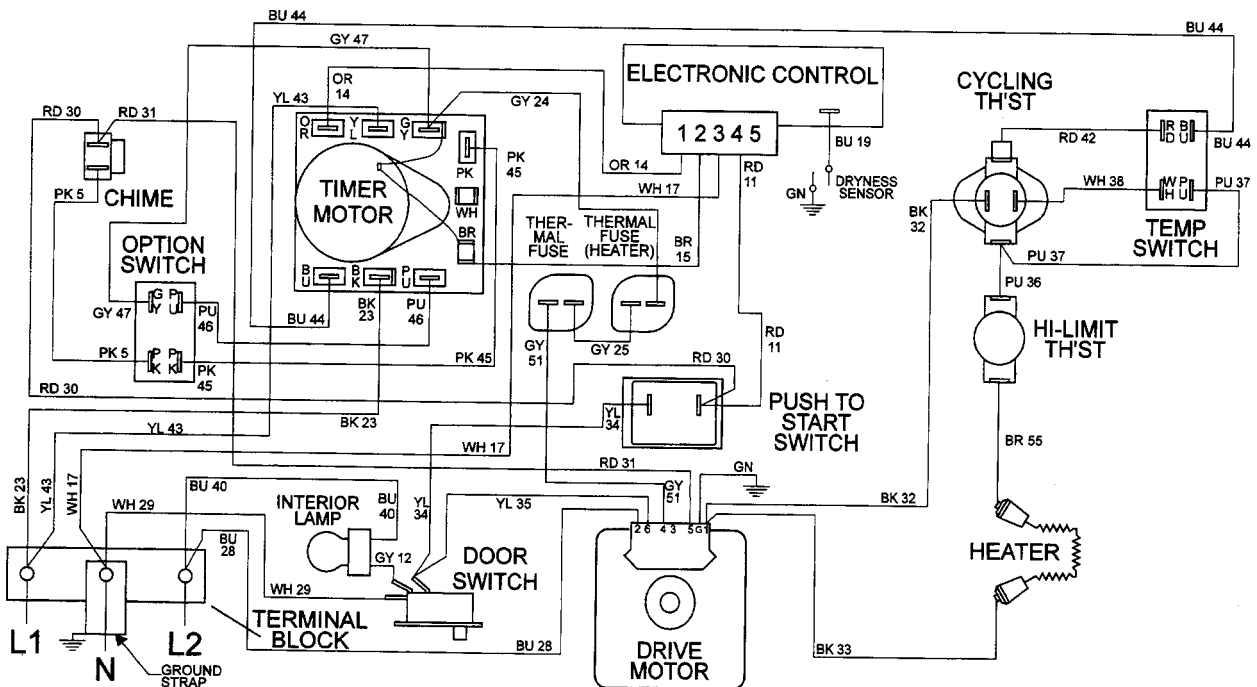
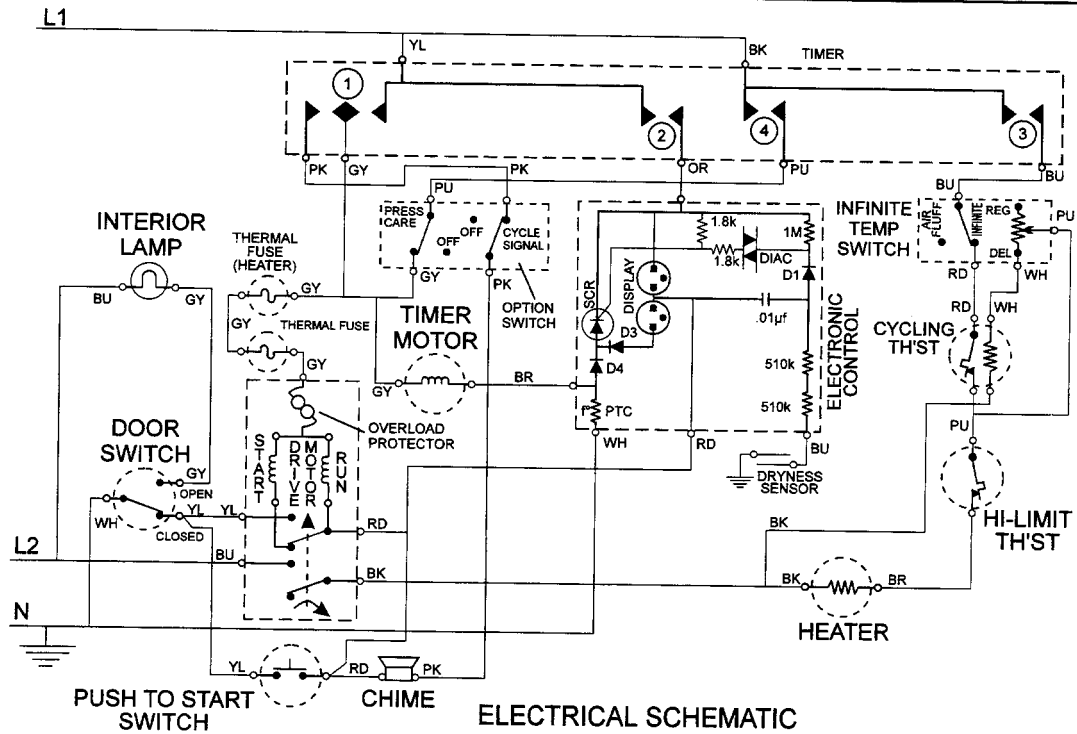

16023110

MDG3000

CIRCUIT	FUNCTION	REG. FABRICS		TIME DRY		PERMANENT PRESS	
		OFF	ON	OFF	ON	OFF	ON
①	GY-PK CHIME YL-GY DRIVE MOTOR	■	■	■	■	■	■
②	YL-OR ELECTRONIC CONTROL	■	■	■	■	■	■
③	BK-BU HEATER	■	■	■	■	■	■
④	BK-PU PRESS CARE	■	■	■	■	■	■

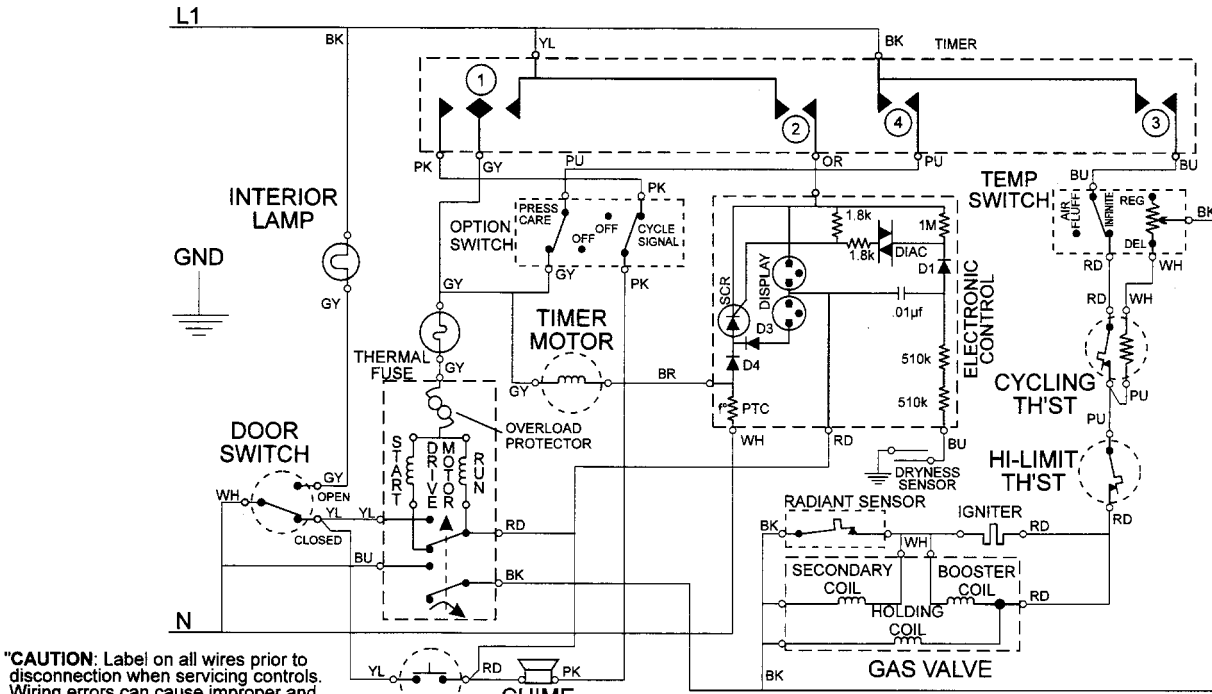

"CAUTION: Label on all wires prior to disconnection when servicing controls. Wiring errors can cause improper and dangerous operation."

"Verify proper operation after servicing."

PUSH TO START SWITCH ELECTRICAL SCHEMATIC

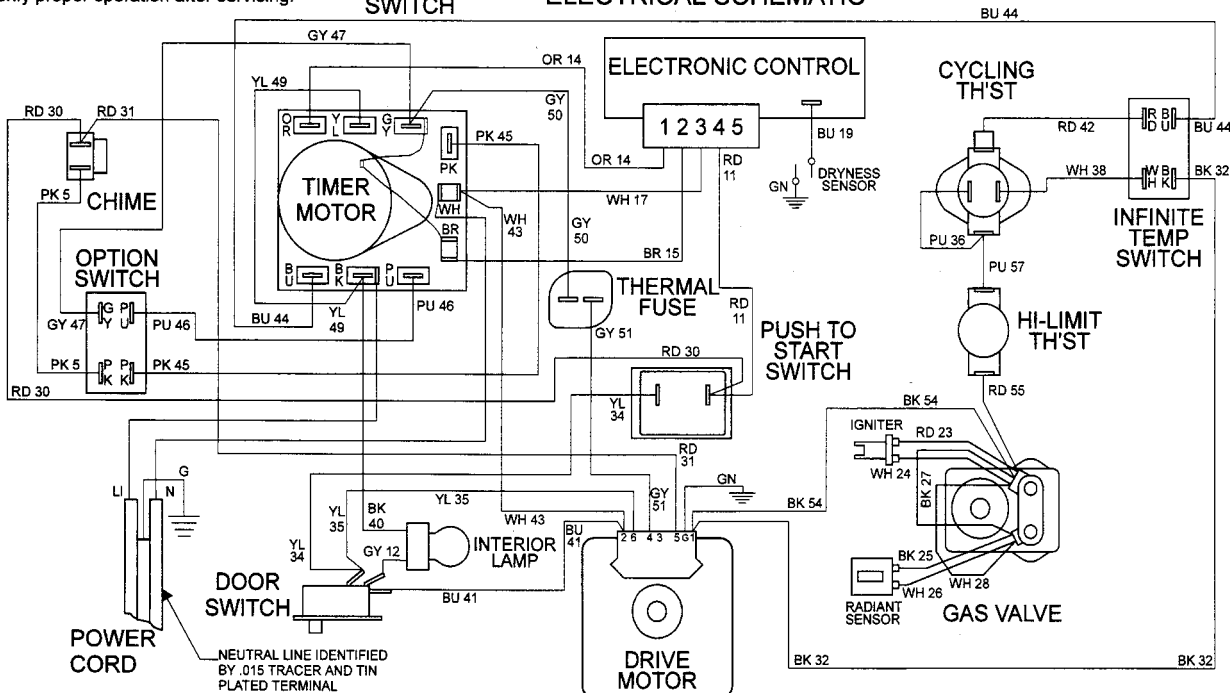

MDE4000AZ, MDE8000AZ

CIRCUIT	FUNCTION	60	120	180	240	300		
①	GY-PK CHIME GY-YL DRIVE MOTOR	[Timing diagram showing pulse activity]						
②	YL-OR ELECTRONIC CONTROL	[Timing diagram showing pulse activity]						
③	BK-RD HEATER	[Timing diagram showing pulse activity]						
④	BK-PU PRESS CARE	[Timing diagram showing pulse activity]						
		OFF	REG. FABRICS	OFF	TIME DRY	OFF	PERMANENT PRESS	PRESS CARE

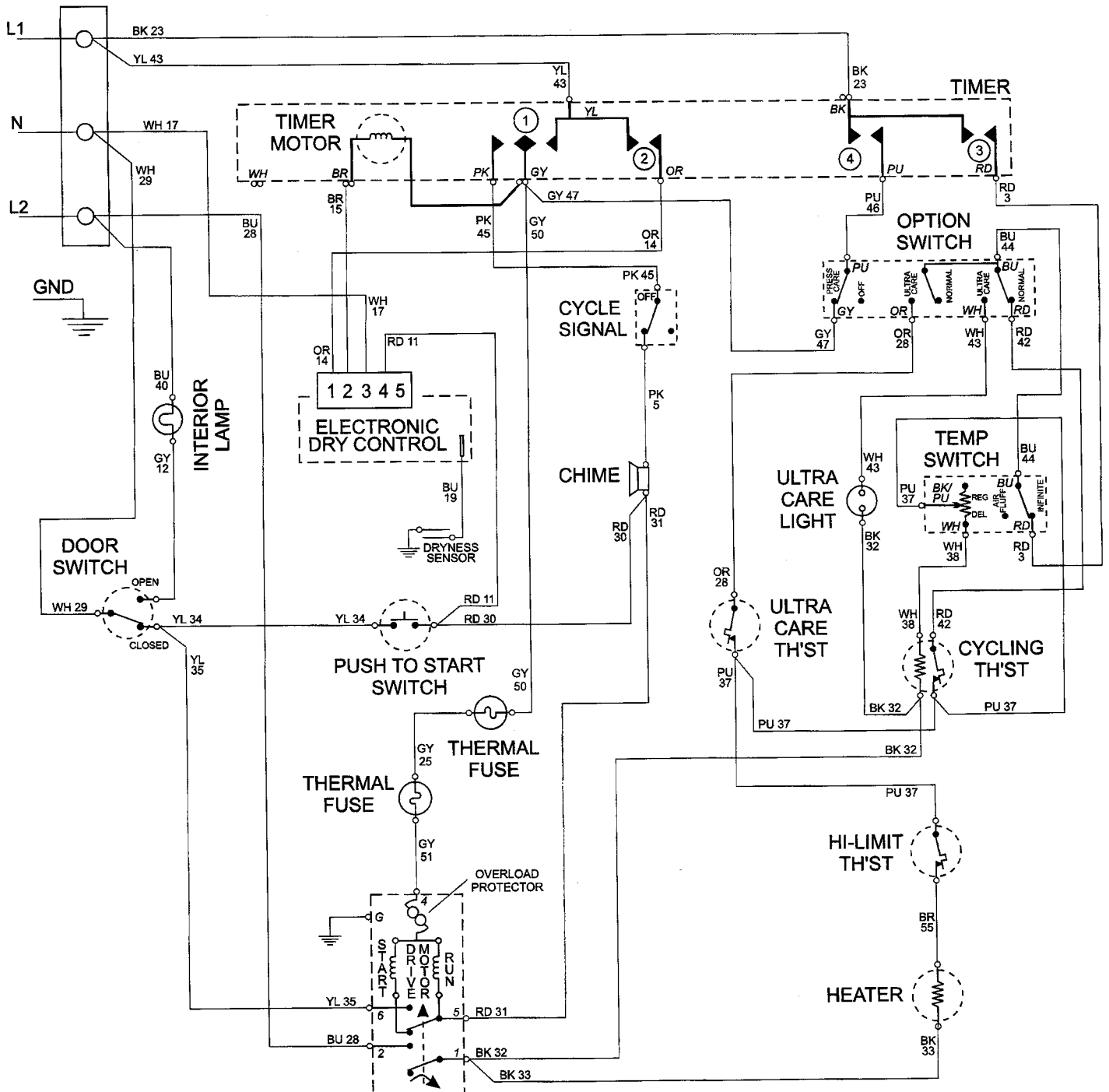

6 3711670-1298

16023110

MDE500AZ

CIRCUIT	FUNCTION	OFF	REG. FABRICS	OFF	TIME DRY	OFF	PERMANENT PRESS
①	BK-GY DRIVE MOTOR BK-BU HEATER						
②	BK-OR TIMER MOTOR						

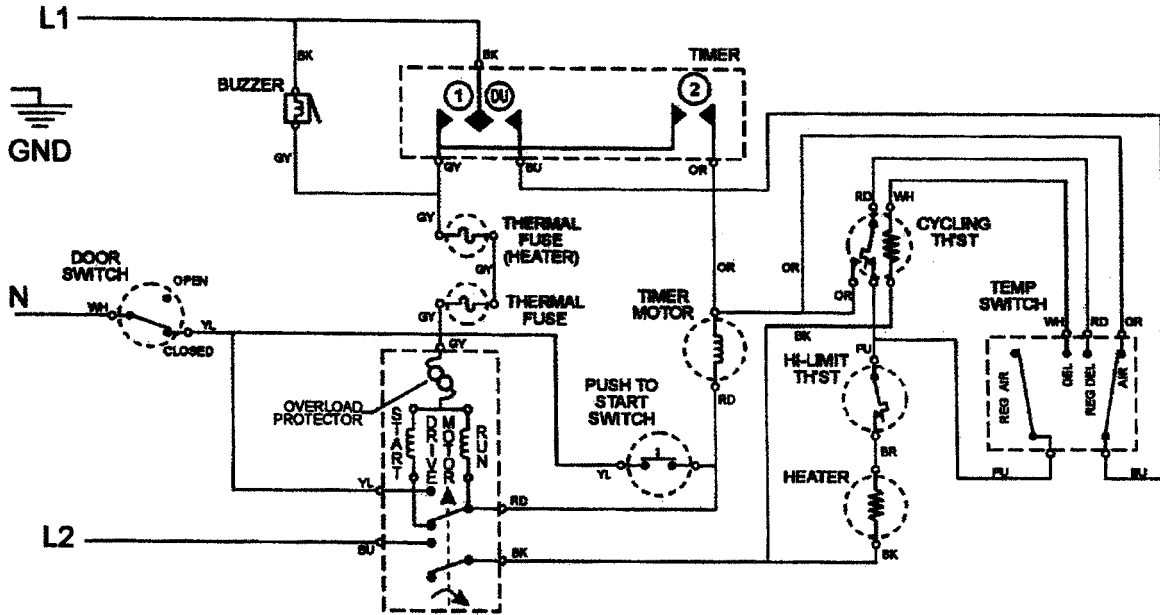

ELECTRICAL SCHEMATIC

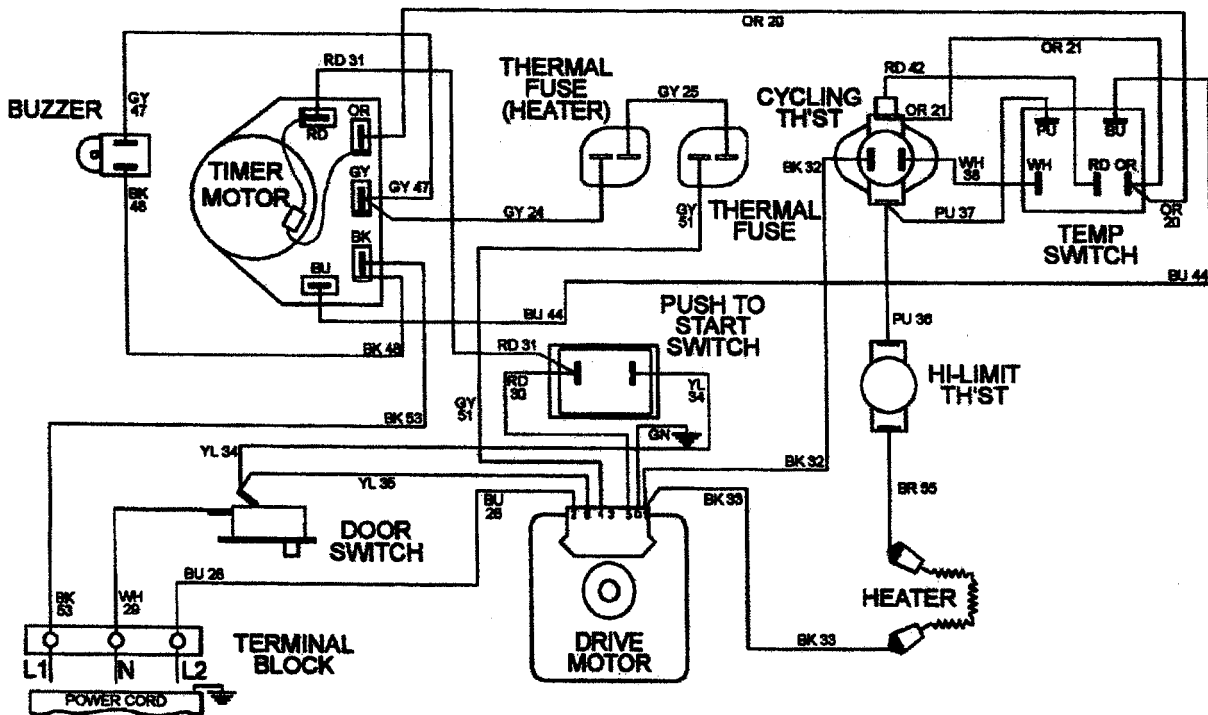

ELECTRICAL WIRING DIAGRAM

MDG6000, MDG7000

CIRCUIT	FUNCTION	REG. FABRICS		TIME DRY		PERMANENT PRESS	
		OFF	ON	OFF	ON	OFF	ON
①	YL-GY DRIVE MOTOR	■	■	■	■	■	■
②	YL-OR TIMER MOTOR	■	■	■	■	■	■
③	BK-BU HEATER	■	■	■	■	■	■
④	BELL ACTUATOR *	■	■	■	■	■	■

* RING ONCE EVERY 75 SECONDS

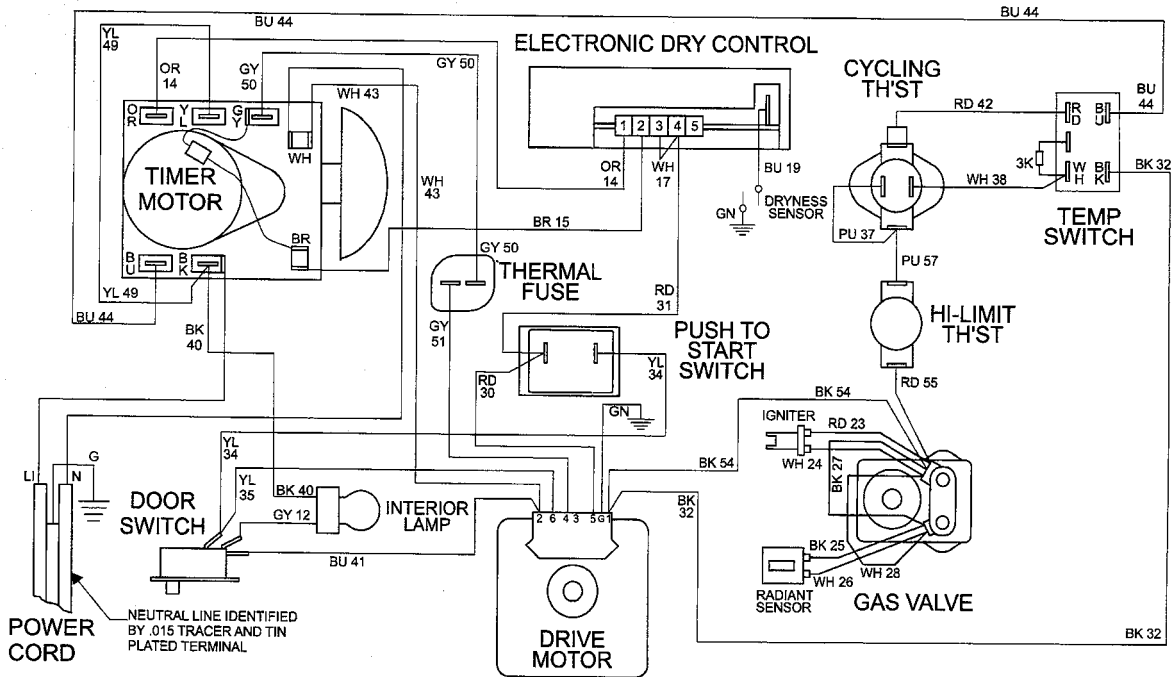
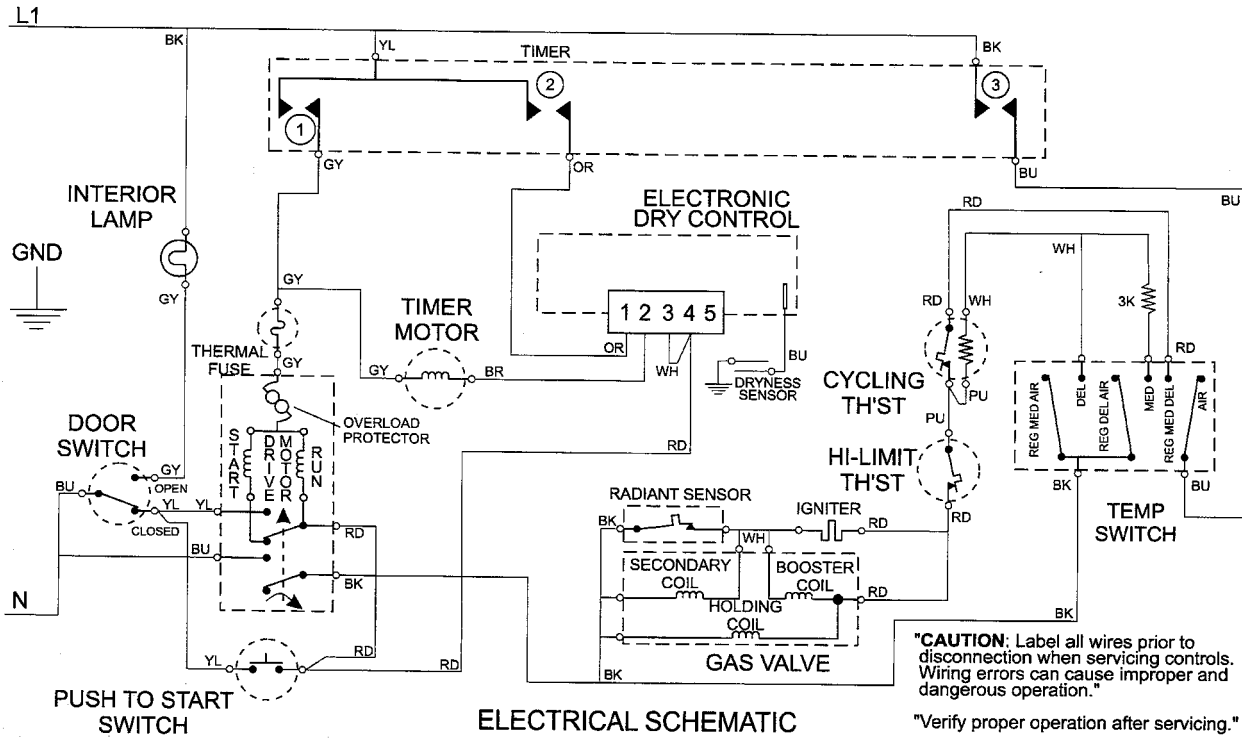

6 3702340-0398

ELECTRICAL WIRING DIAGRAM

MDE6000AZ, MDE7000AZ

CIRCUIT	FUNCTION	OFF	REG. FABRICS	OFF	TIME DRY	OFF	PERMANENT PRESS
①	YL-GY DRIVE MOTOR						PRESS CARE
②	YL-OR TIMER MOTOR						
③	BK-BU HEATER						
④	BELL ACTUATOR*						

* RING ONCE EVERY 75 SECONDS

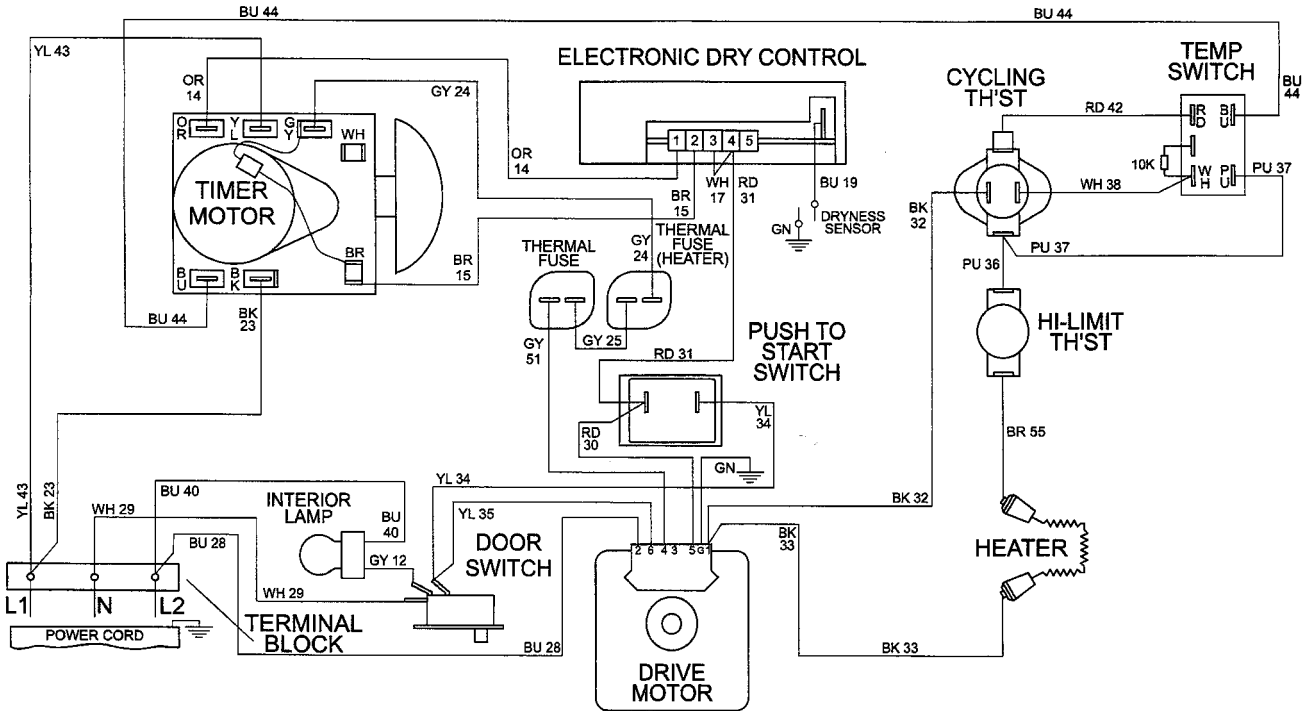
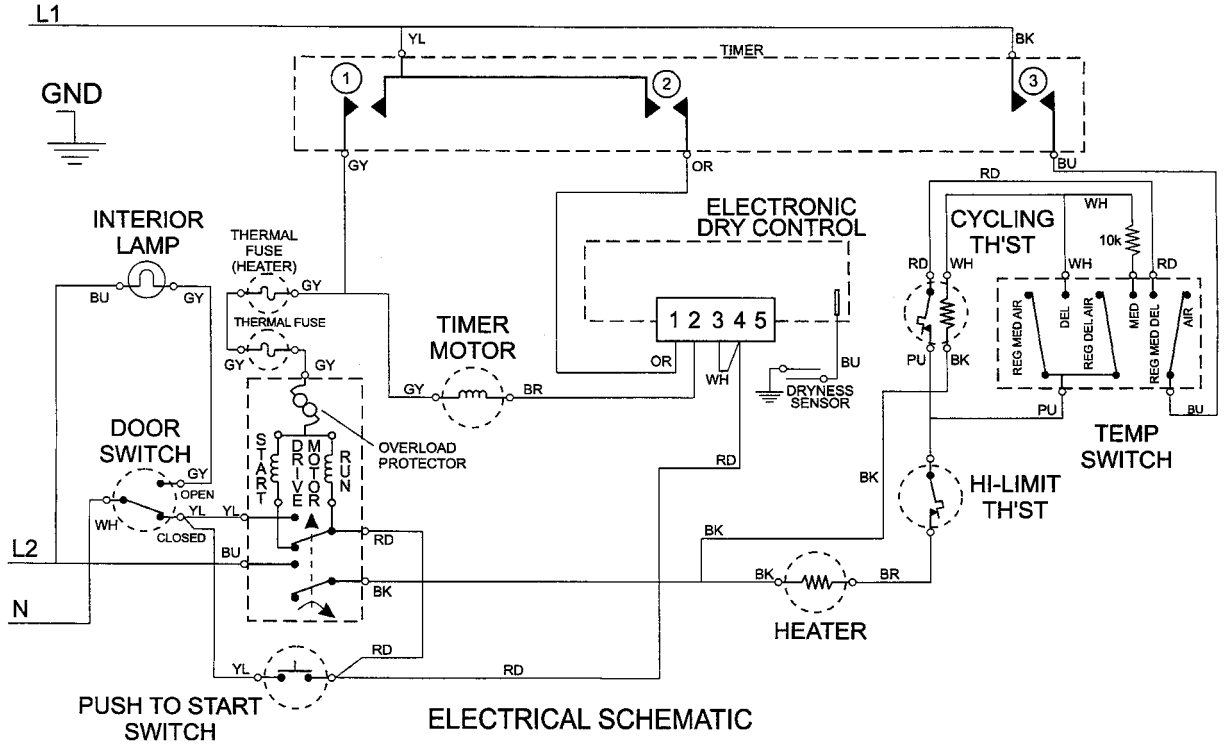

6 3702420-0398

ELECTRICAL WIRING DIAGRAM

MDE6000AU/AY, MDE7000AY

CIRCUIT	FUNCTION	OFF	REG. FABRICS	OFF	TIME DRY	OFF	PERMANENT PRESS
①	YL-GY DRIVE MOTOR						PRESS CARE
②	YL-OR TIMER MOTOR						
③	BK-BU HEATER						
④	BELL ACTUATOR *						

* RING ONCE EVERY 75 SECONDS

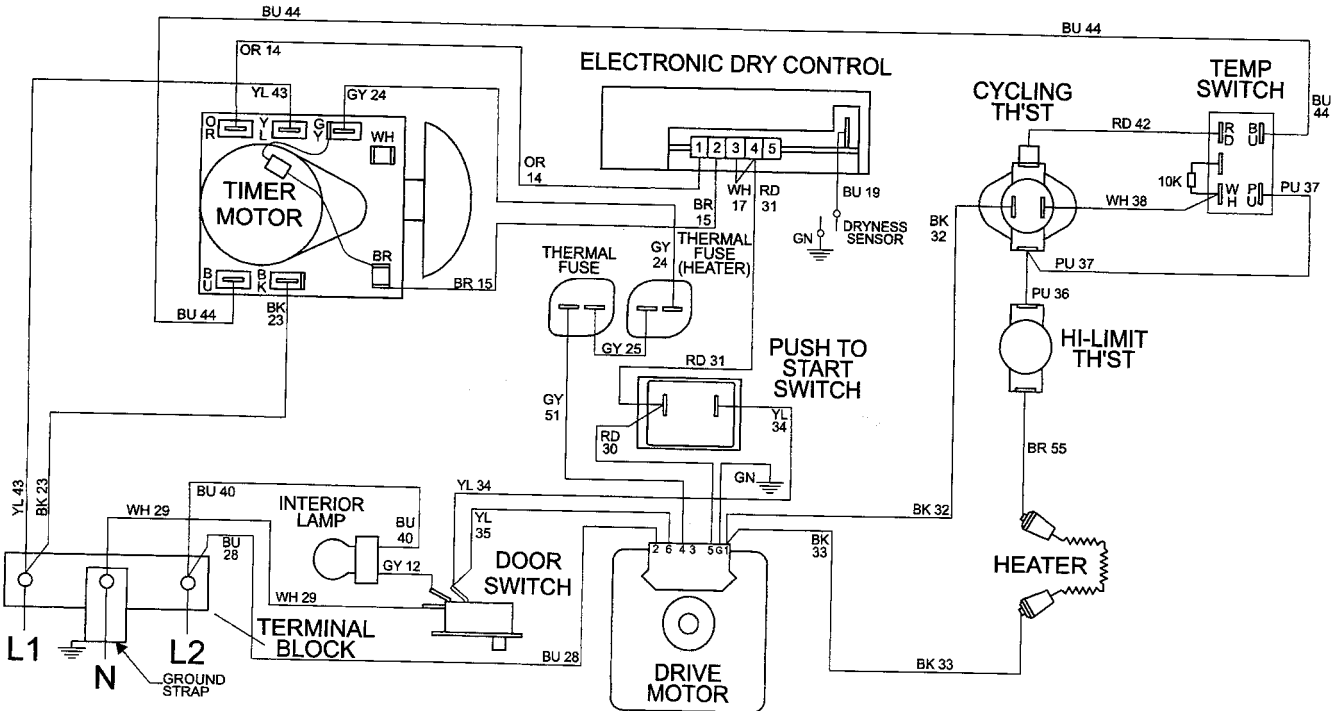
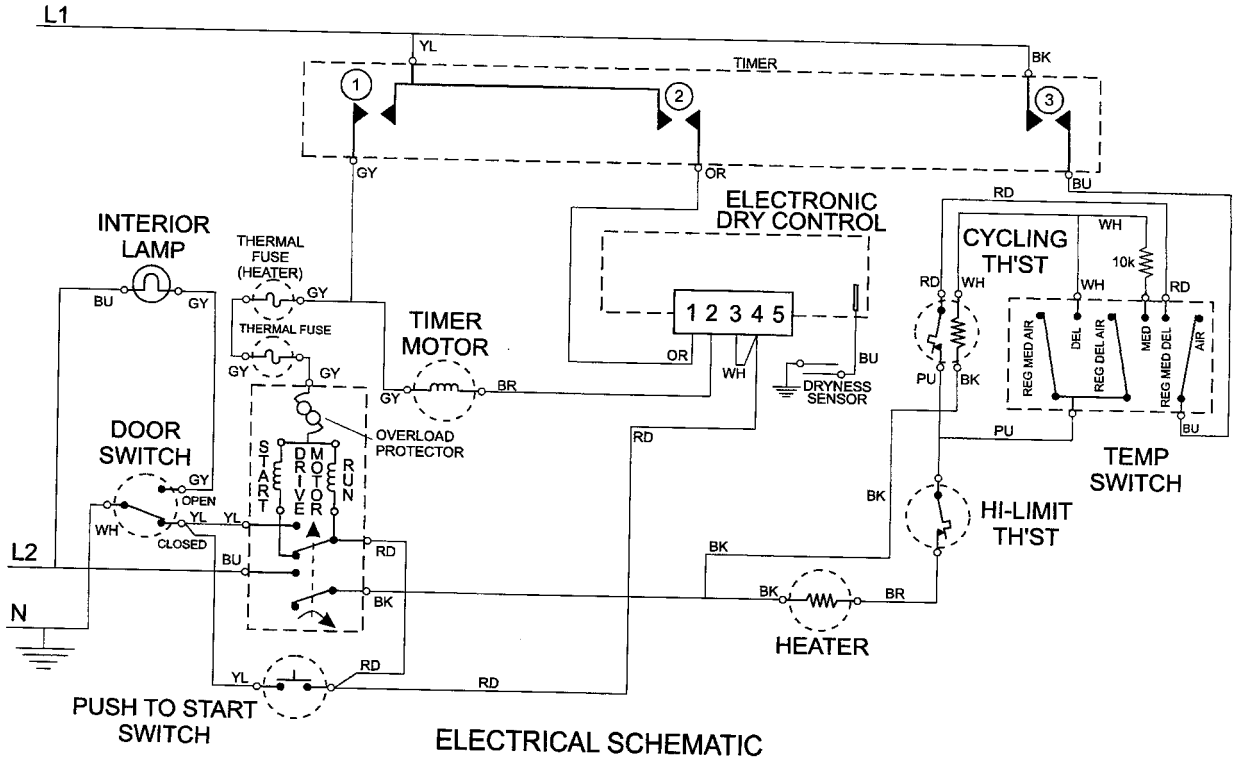

6 3702330-0398

ELECTRICAL WIRING DIAGRAM

16023110

MDE7057AY

CIRCUIT	FUNCTION	OFF	REG. FABRICS	OFF	TIME DRY	OFF	PERMANENT PRESS	OFF
①	YL-GY DRIVE MOTOR		■		■		■	
②	YL-OR TIMER MOTOR		■		■		■	
③	BK-BU HEATER		■		■		■	
④	PK-BK BUZZER/HEATER		■		■		■	

**ON* 5 SECONDS EVERY 5 MINUTES

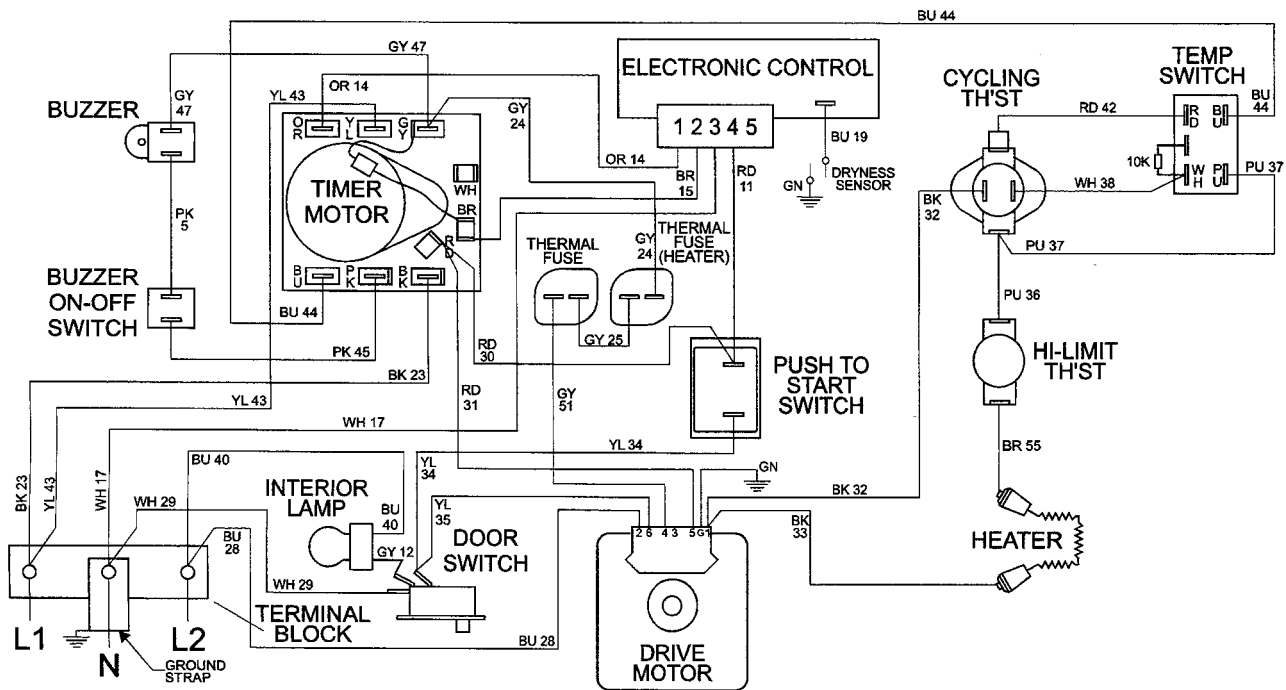
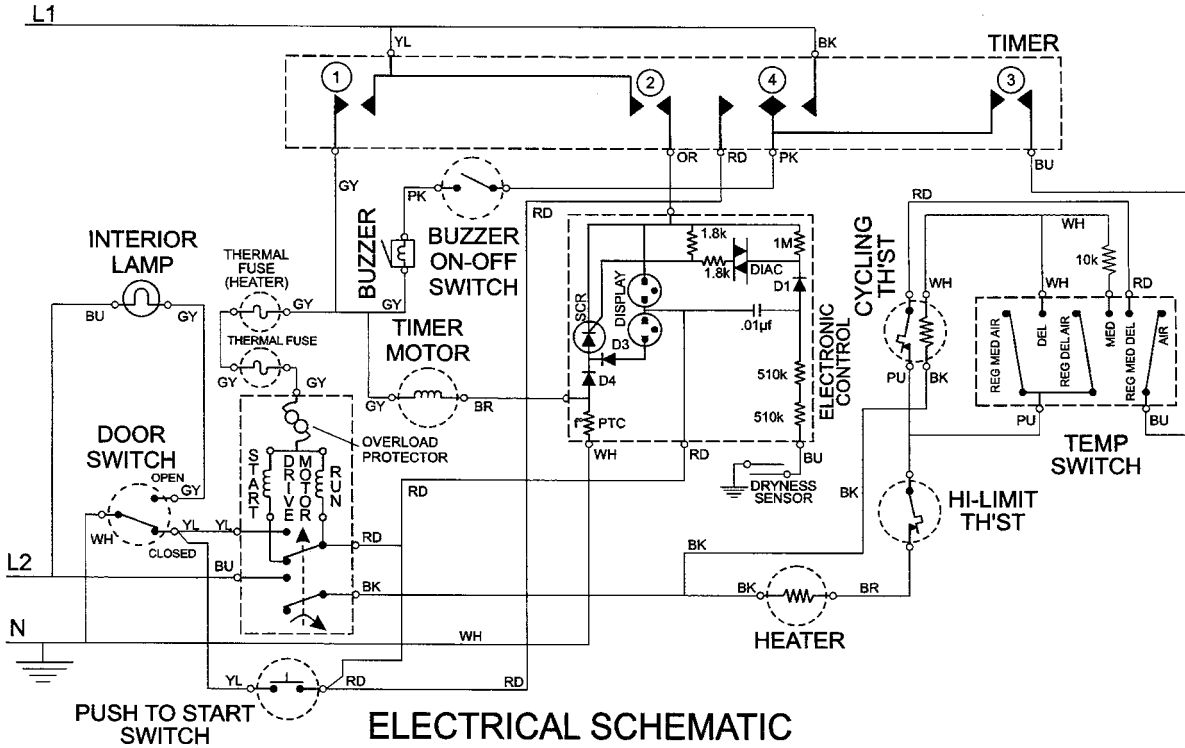

63710900-0998

ELECTRICAL WIRING DIAGRAM

16023110

MDG4000AW/AX/BW, MDG8000AW/BW

CIRCUIT	FUNCTION	60	120	180	240	300	
①	GY-PK CHIME GY-YL DRIVE MOTOR	[Wiring diagram showing active periods for Chime and Drive Motor]					
②	YL-OR ELECTRONIC CONTROL	[Wiring diagram showing active periods for Electronic Control]					
③	BK-RD HEATER	[Wiring diagram showing active periods for Heater]					
④	BK-PU PRESS CARE	[Wiring diagram showing active periods for Press Care]					
		REG. FABRICS	TIME DRY	PERMANENT PRESS	PRESS CARE		

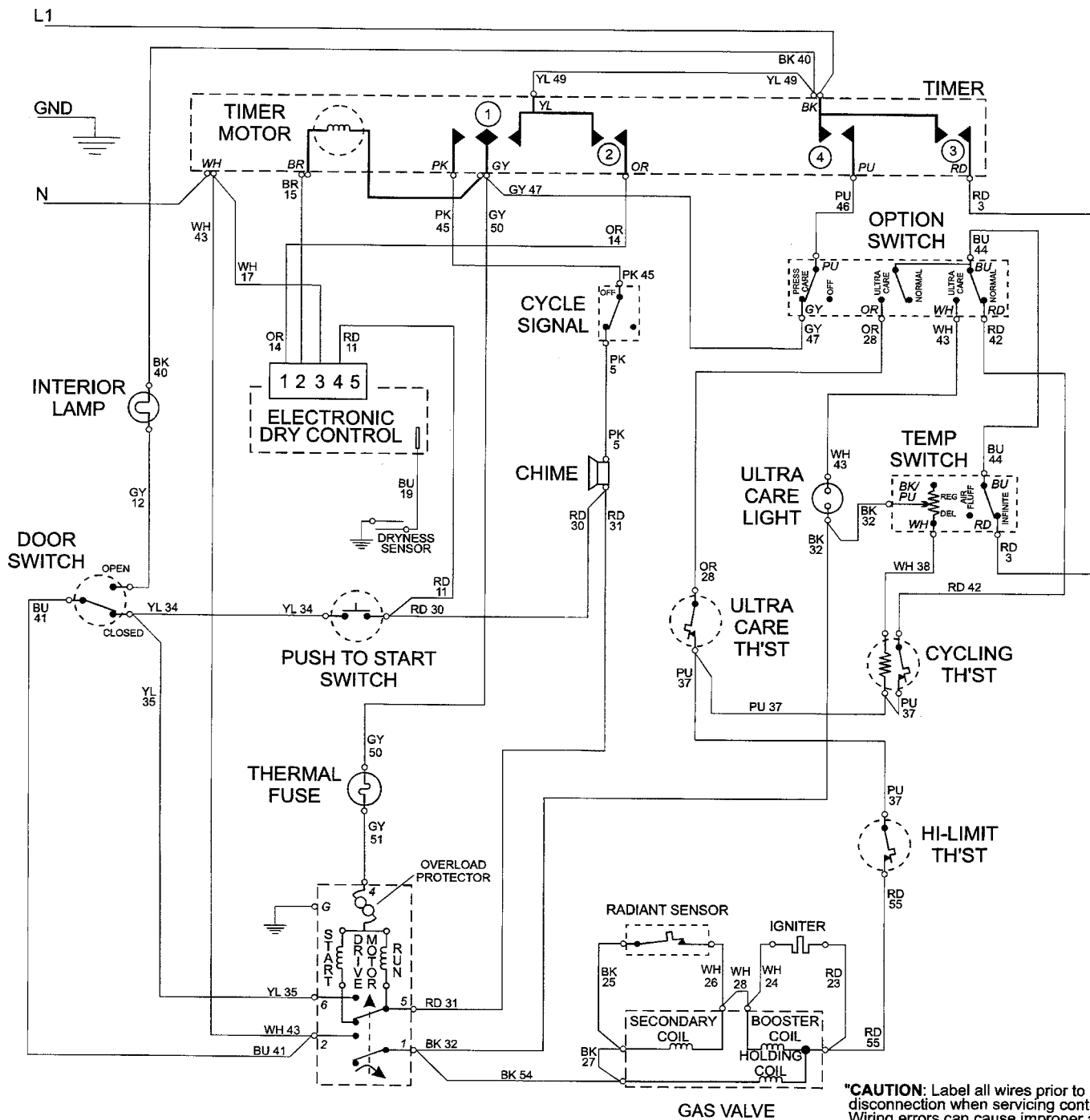

6 3711660-1298

CAUTION: Label all wires prior to disconnection when servicing controls. Wiring errors can cause improper and dangerous operation.

"Verify proper operation after servicing."

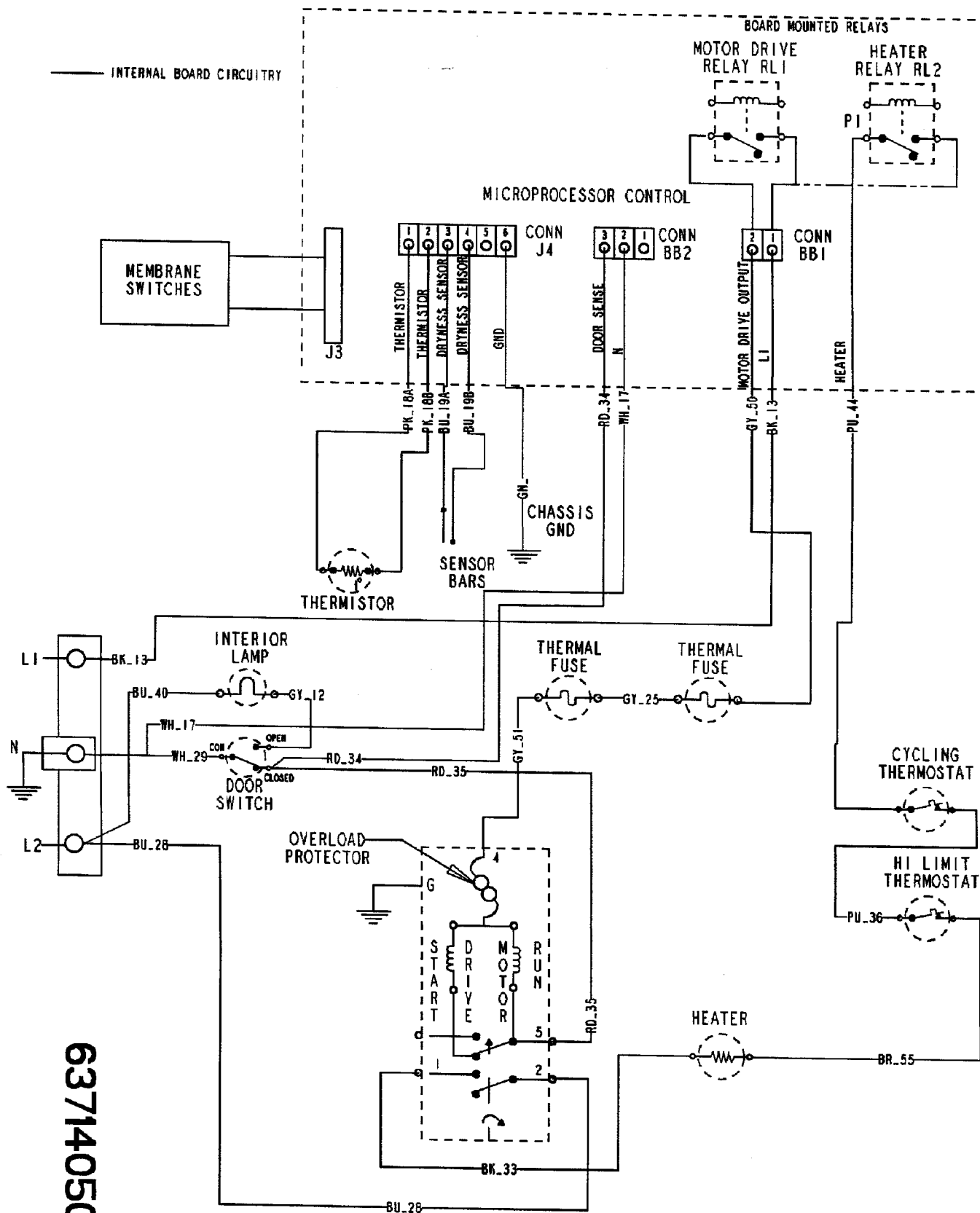

63714050

MDE5500 (Canada)

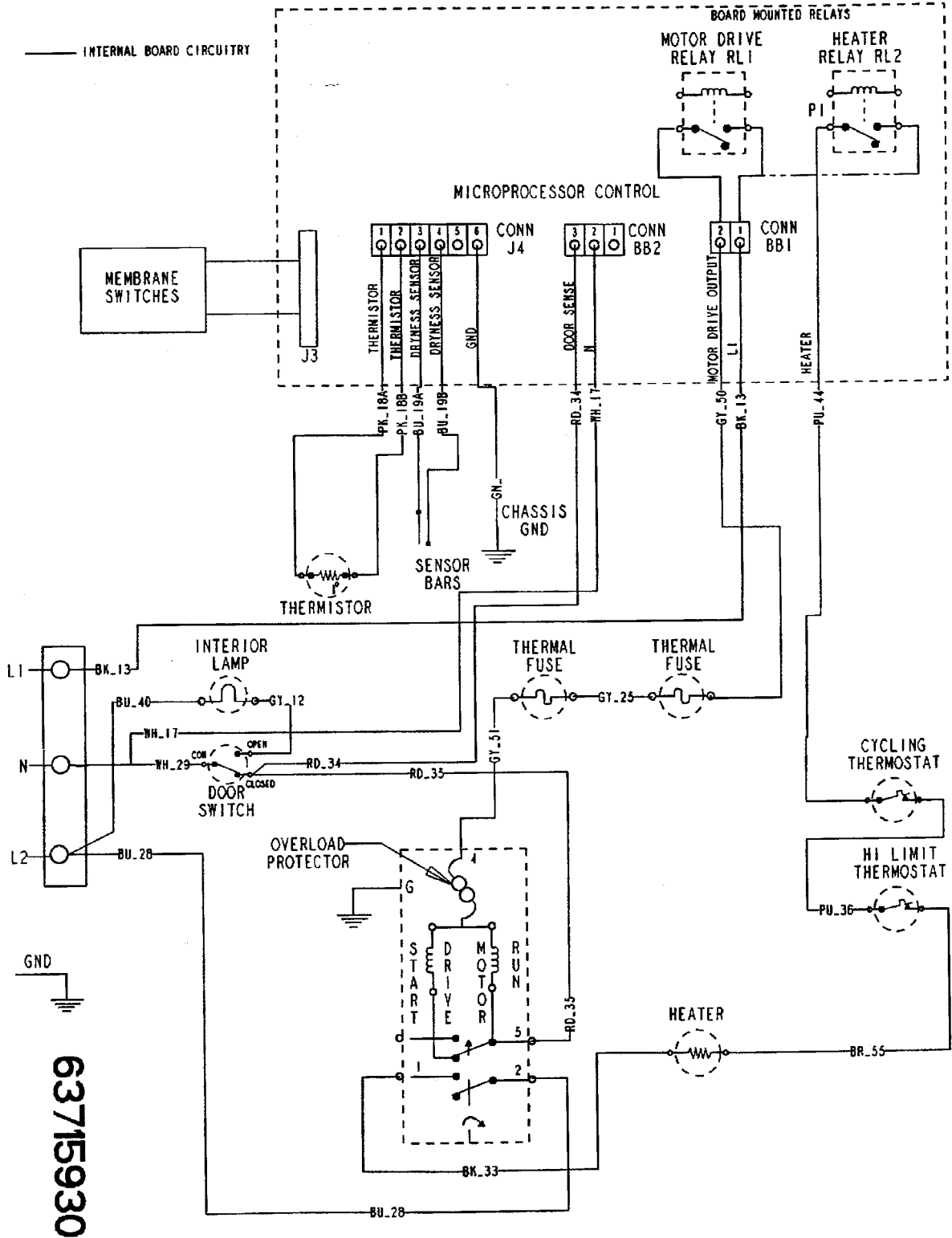

63715930

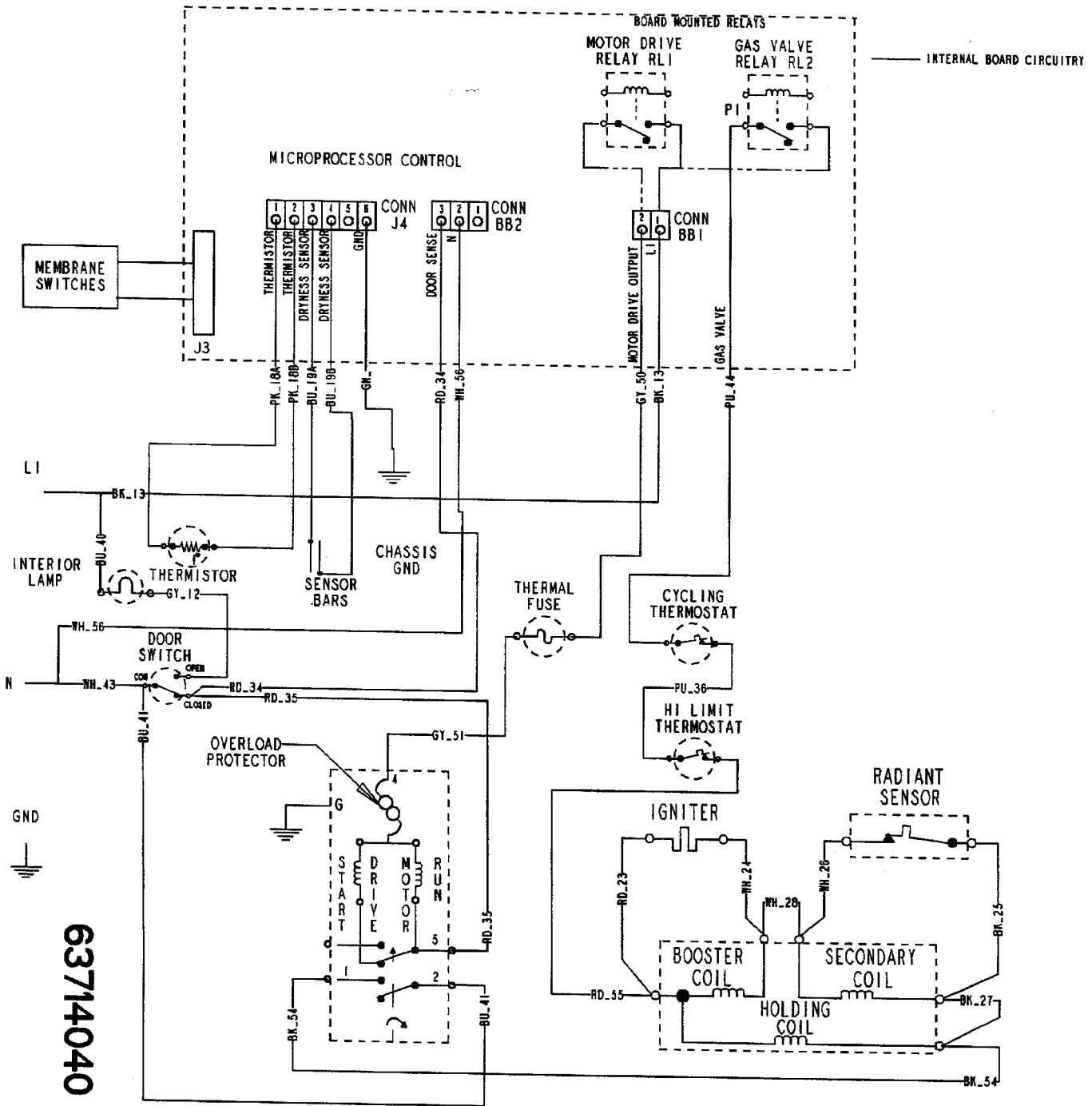

63714040

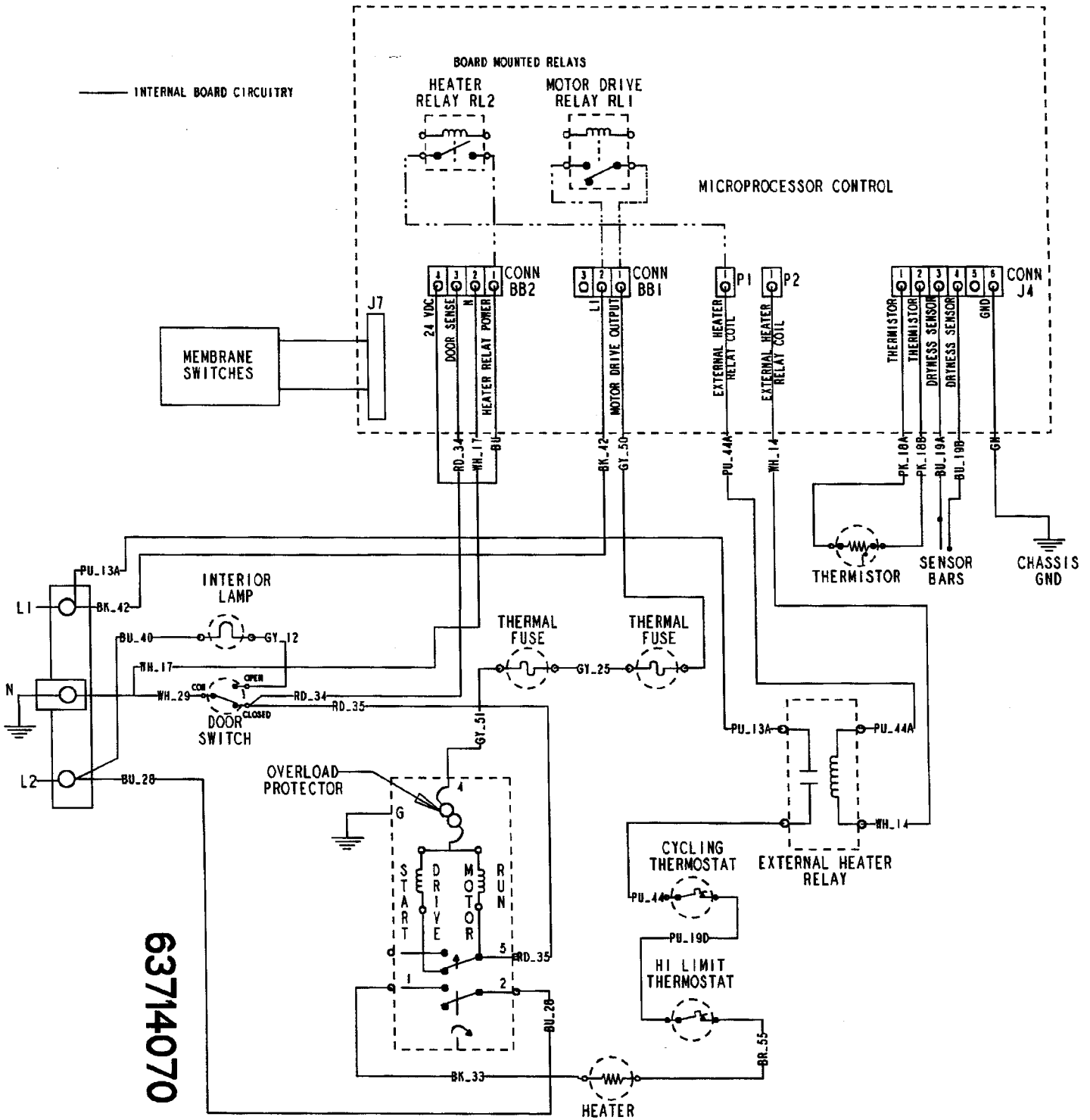

63714070

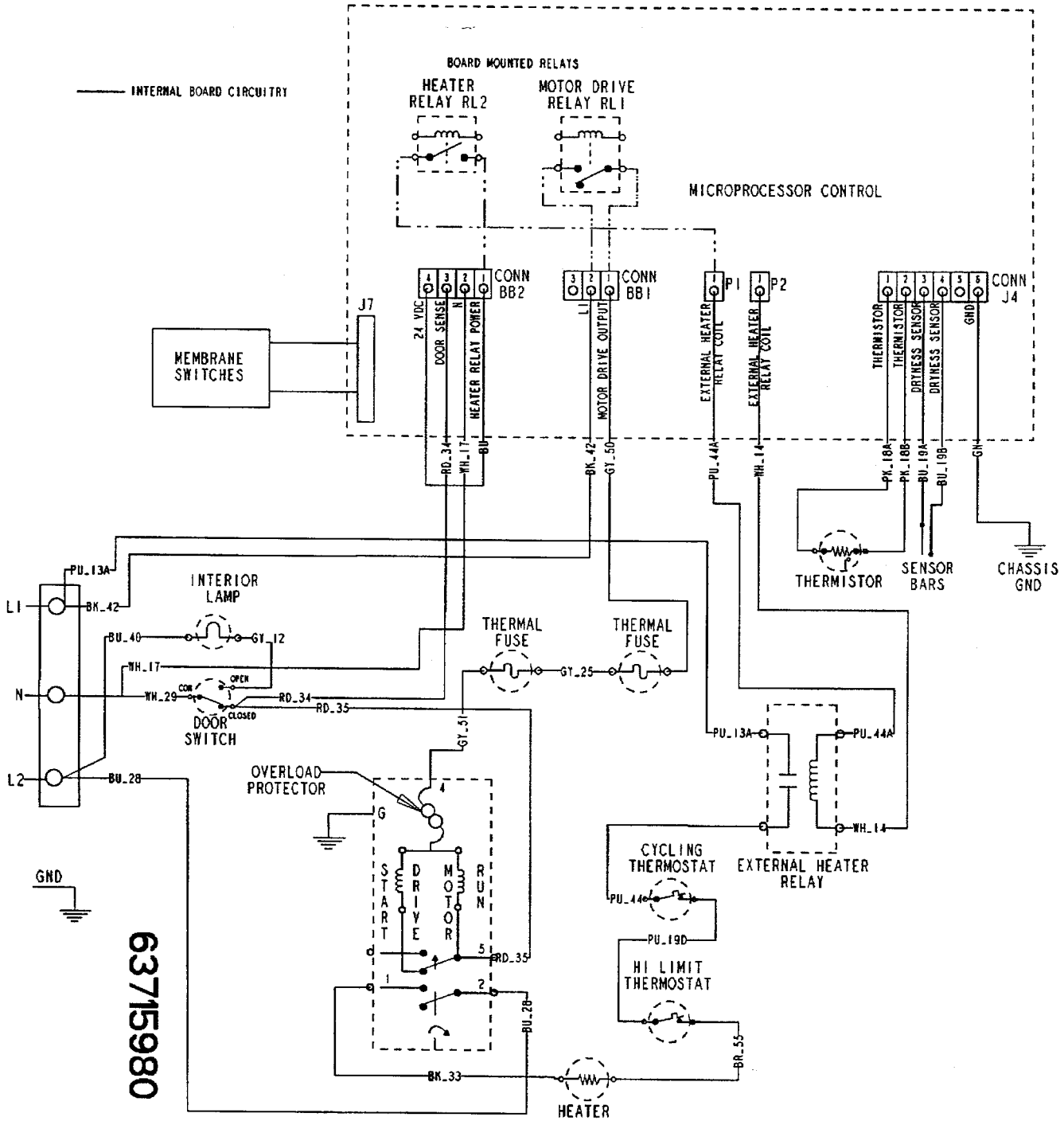

MDE7600AYW MDE7600AYQ MDE7600AUW

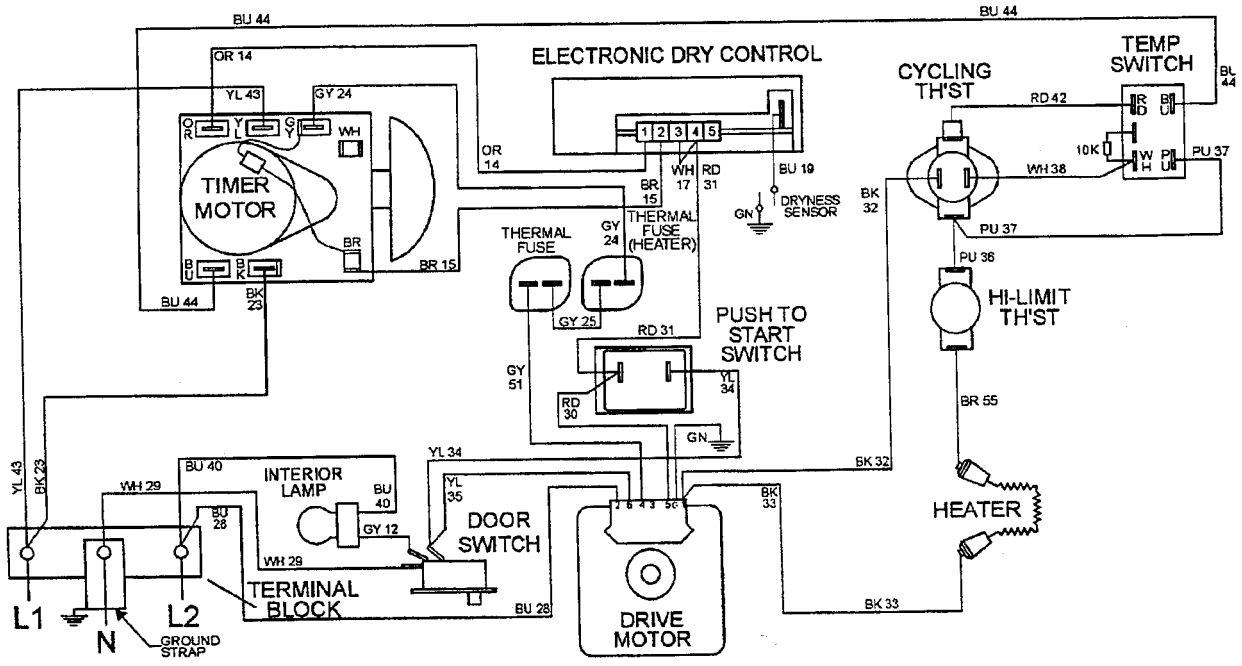
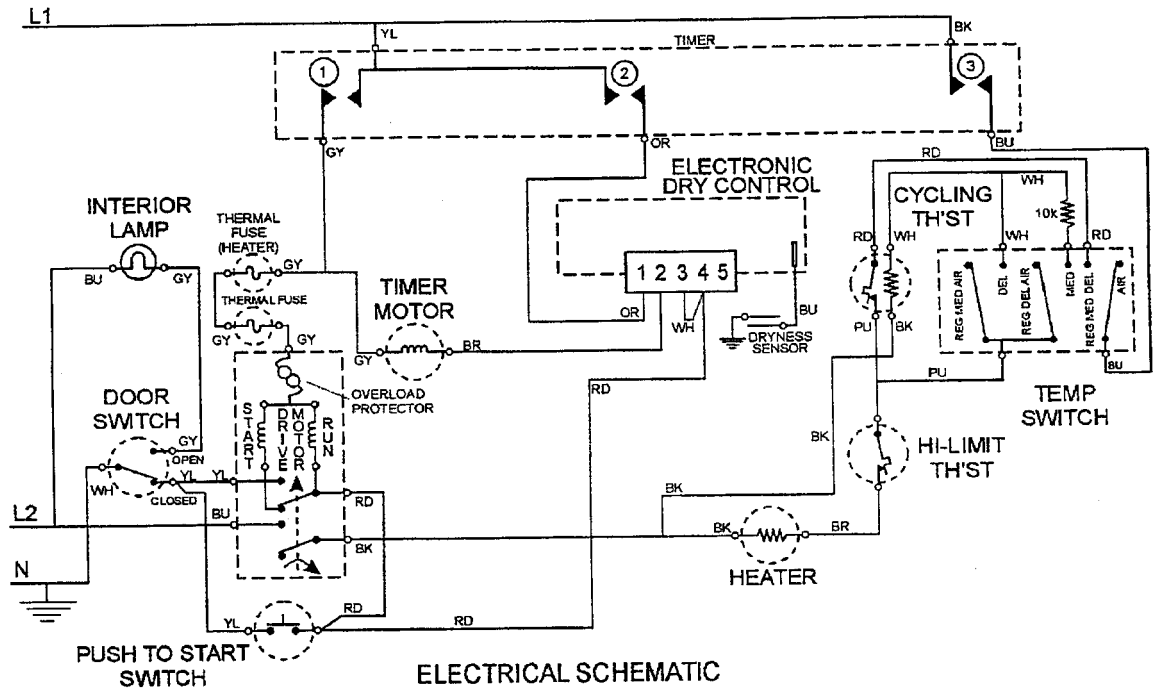

6 3702330-0398

ELECTRICAL WIRING DIAGRAM

MDE7600AZW MDE7600AZQ (Canada)

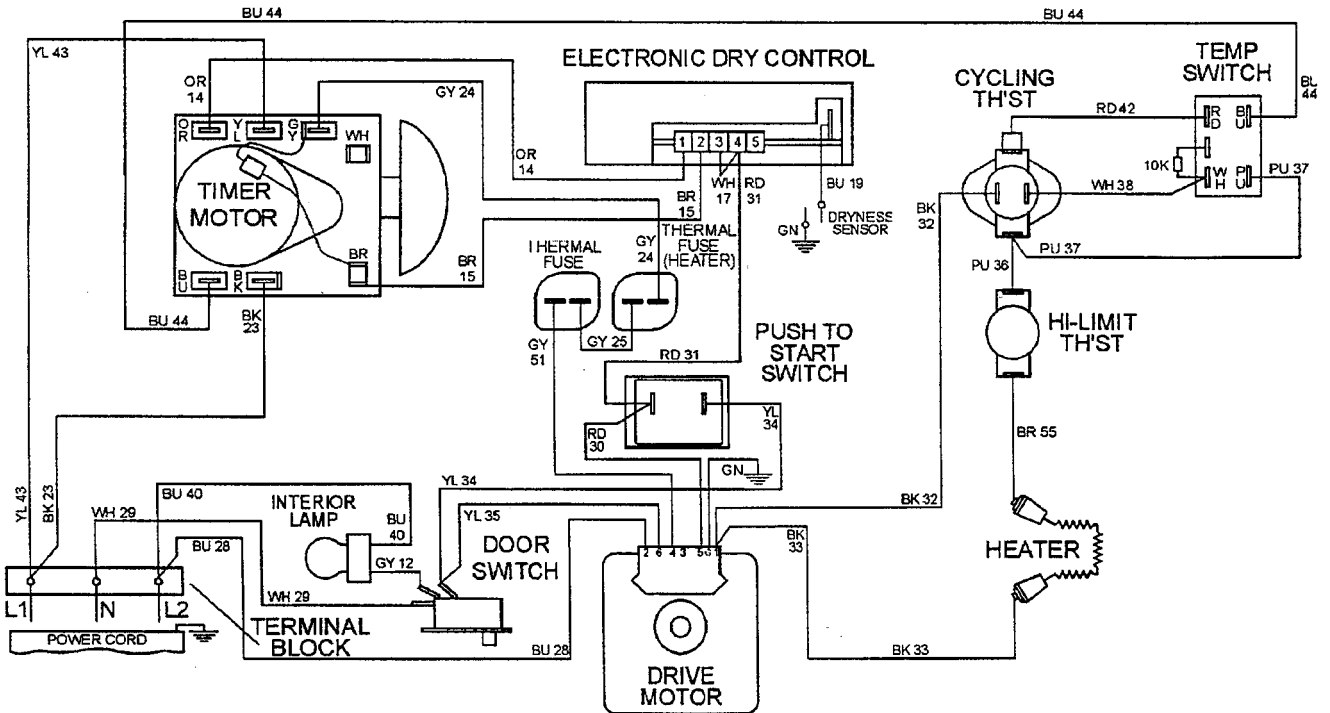
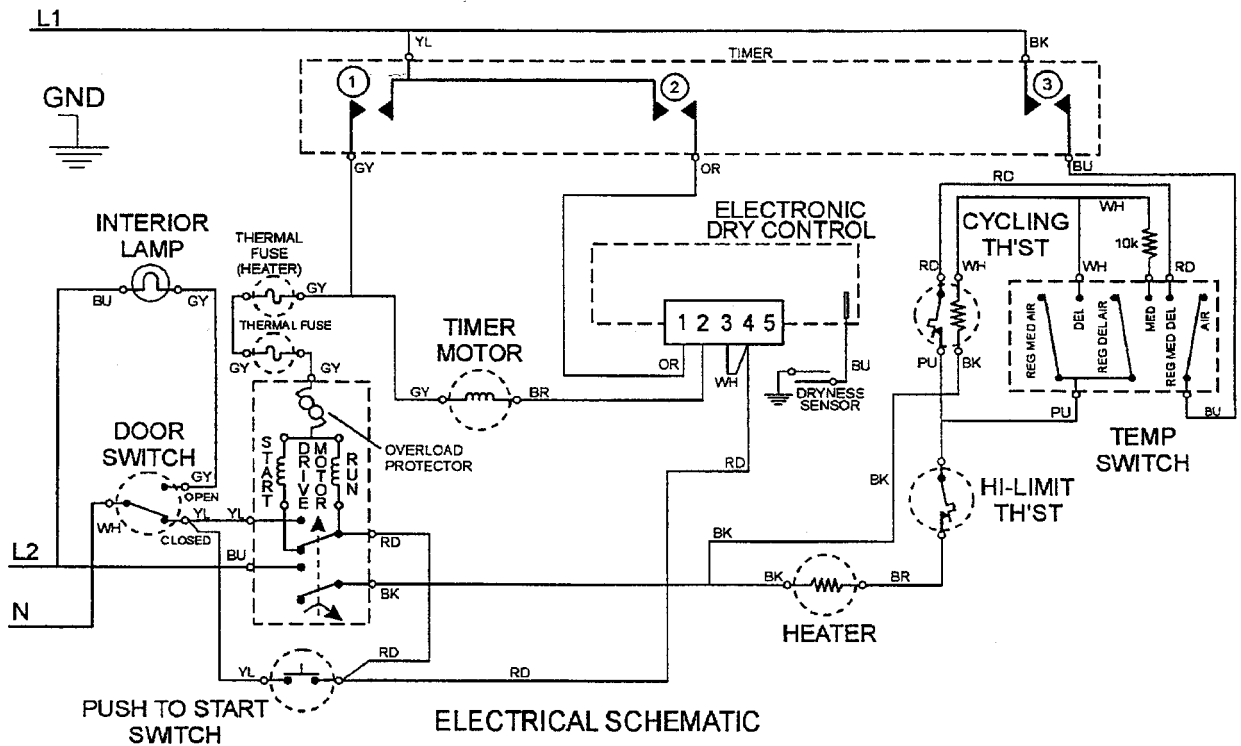

6 3702420-0398

MDE8600AYW MDE8600AYQ

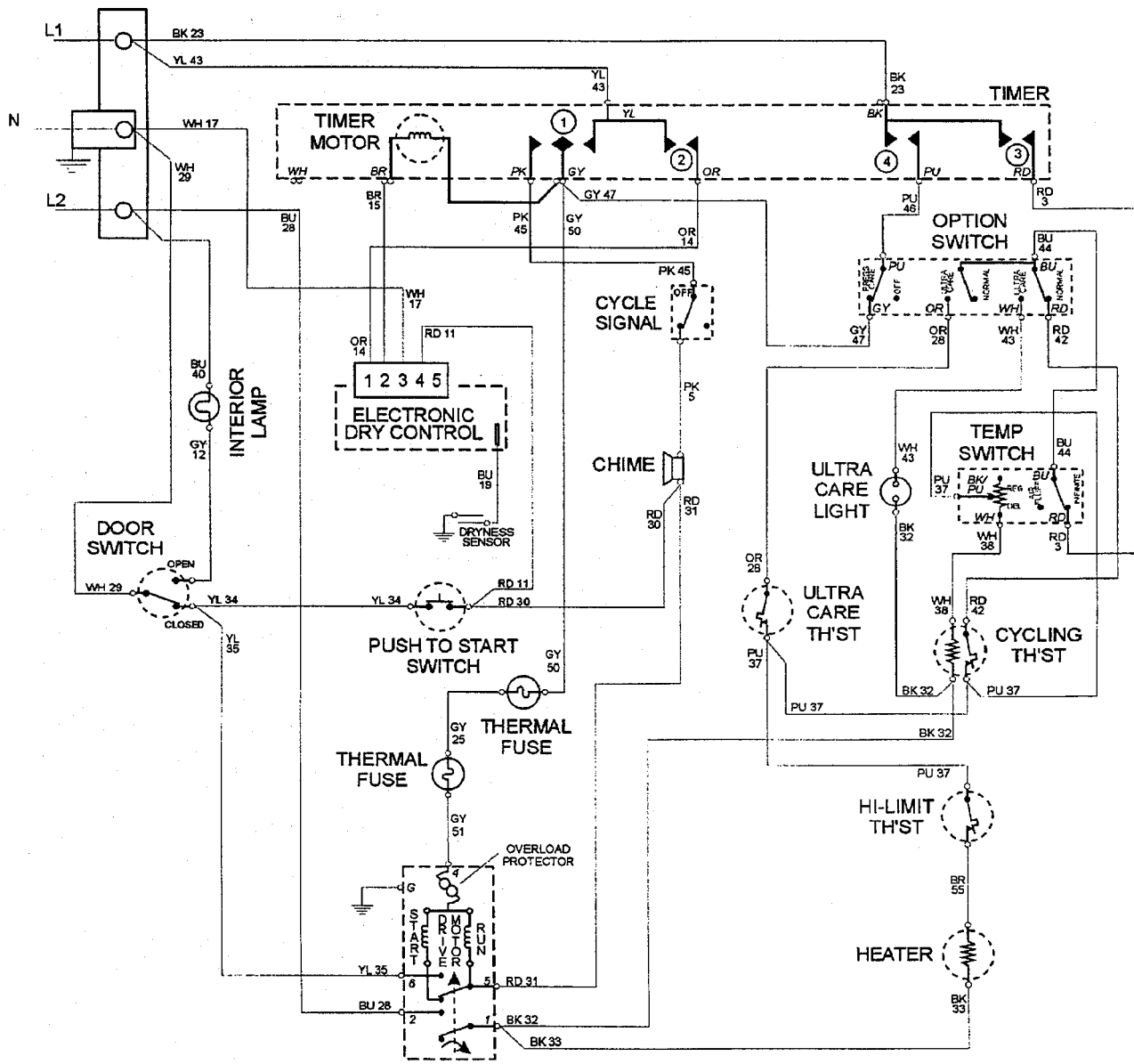

6 3711650-1298

MDE8600AZW (Canada)

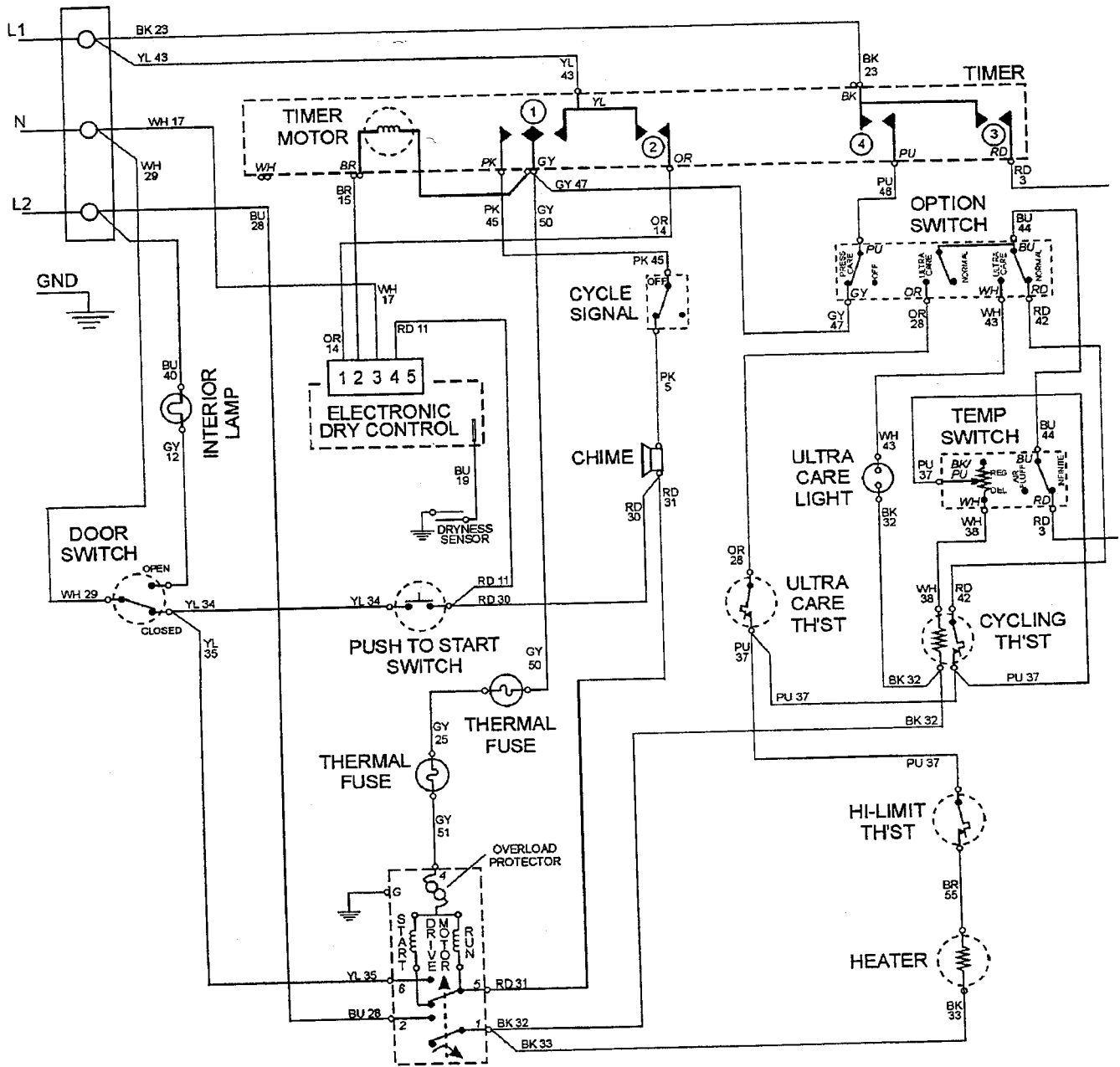

MDG8600AWW MDG8600AWQ

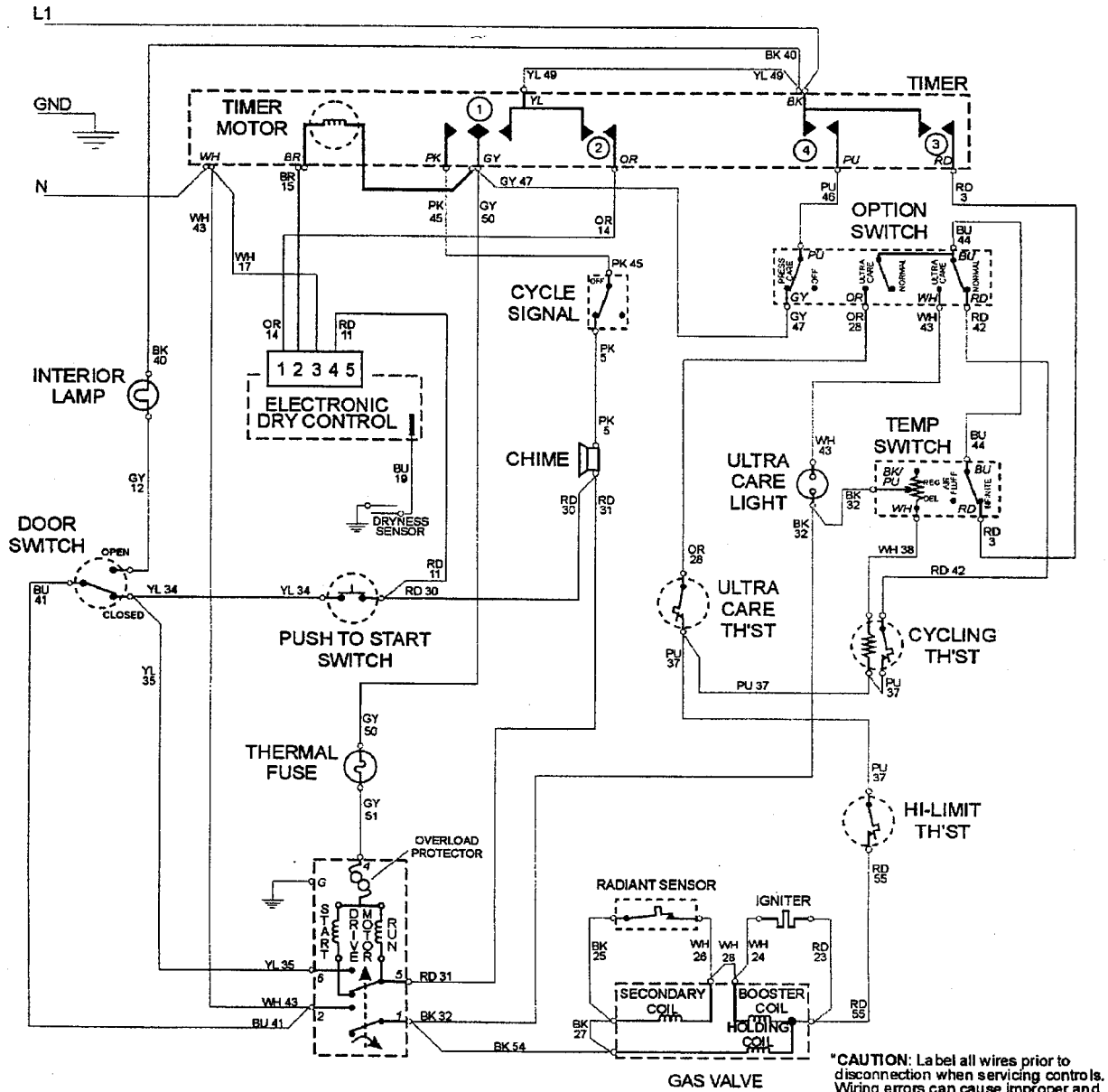

"CAUTION: Label all wires prior to disconnection when servicing controls. Wiring errors can cause improper and dangerous operation."

"Verify proper operation after servicing."

6 3711660-1298

MDE6200AYW MDE6200AYQ

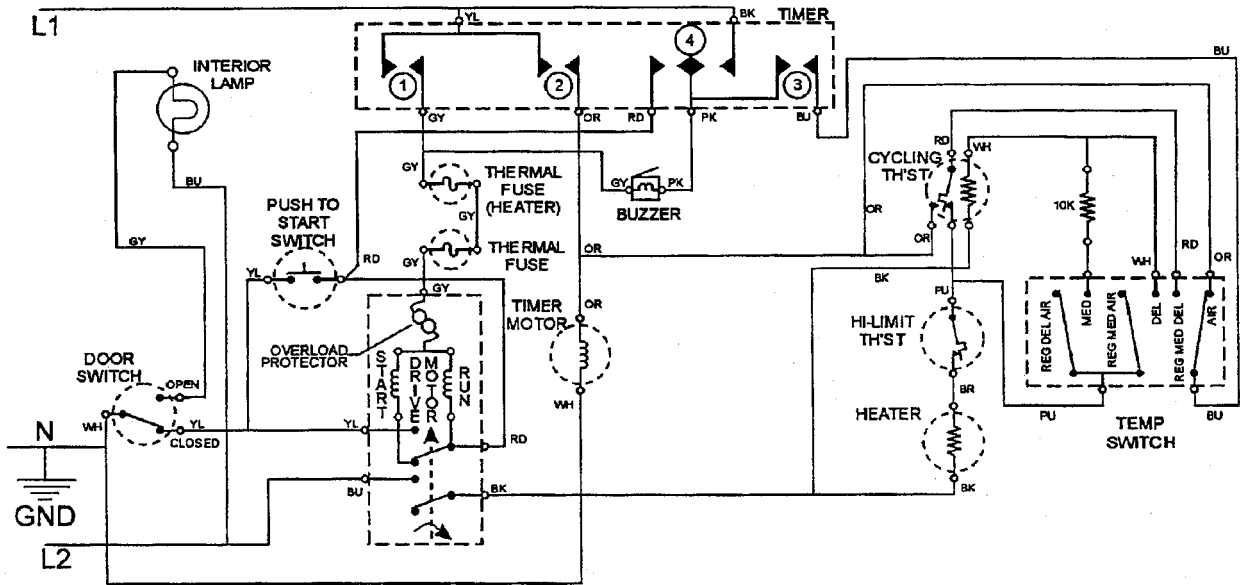

ELECTRICAL SCHEMATIC

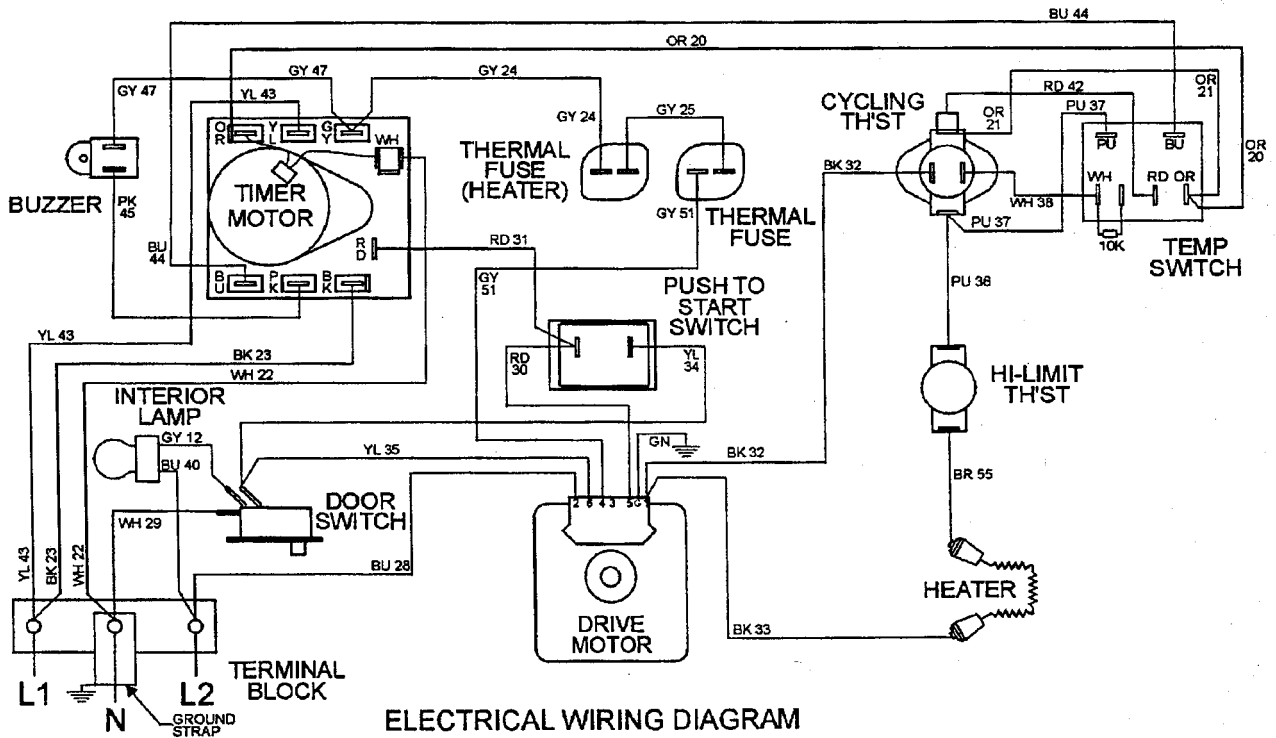

ELECTRICAL WIRING DIAGRAM

63715890

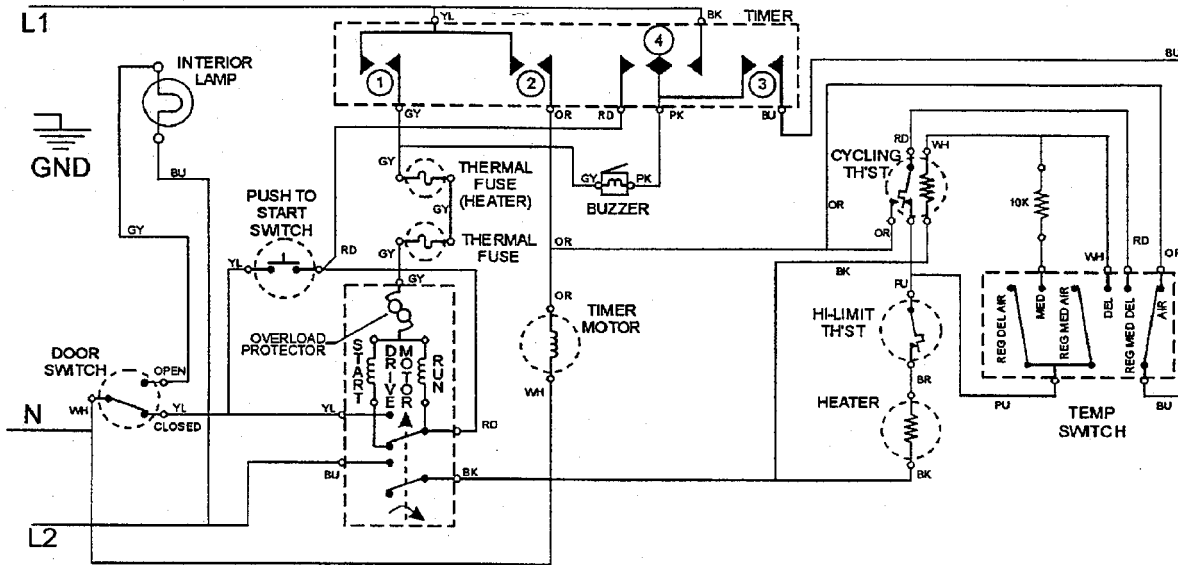

ELECTRICAL SCHEMATIC

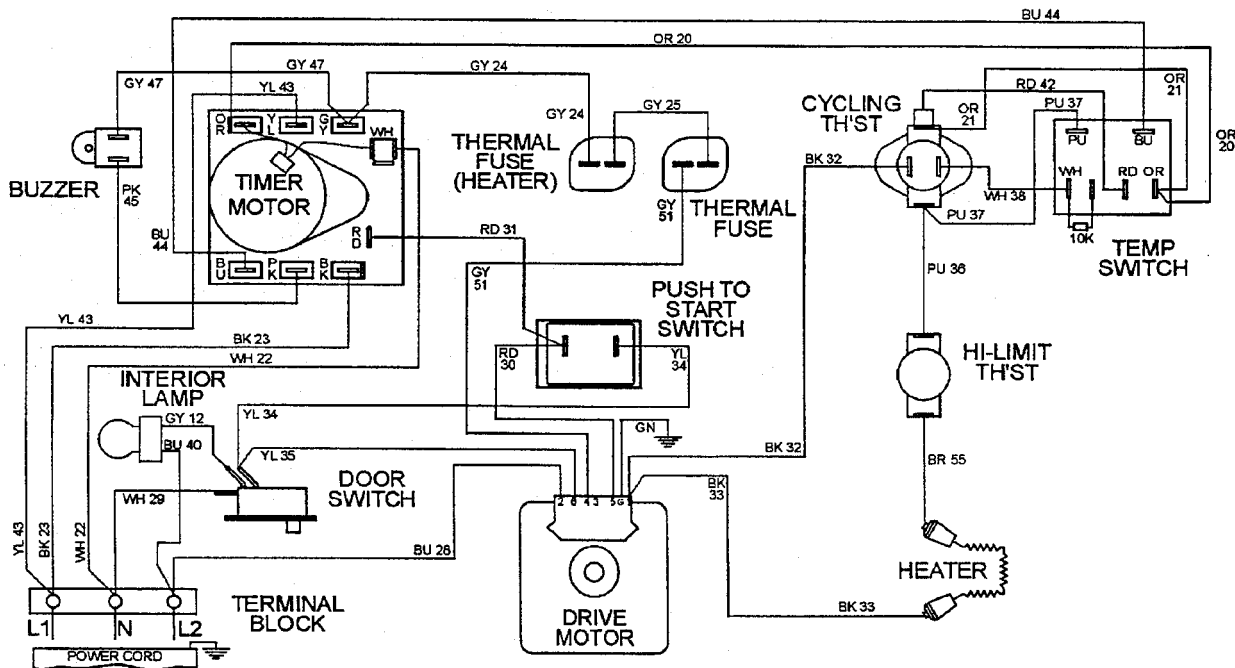

ELECTRICAL WIRING DIAGRAM

63715920

MDE6800

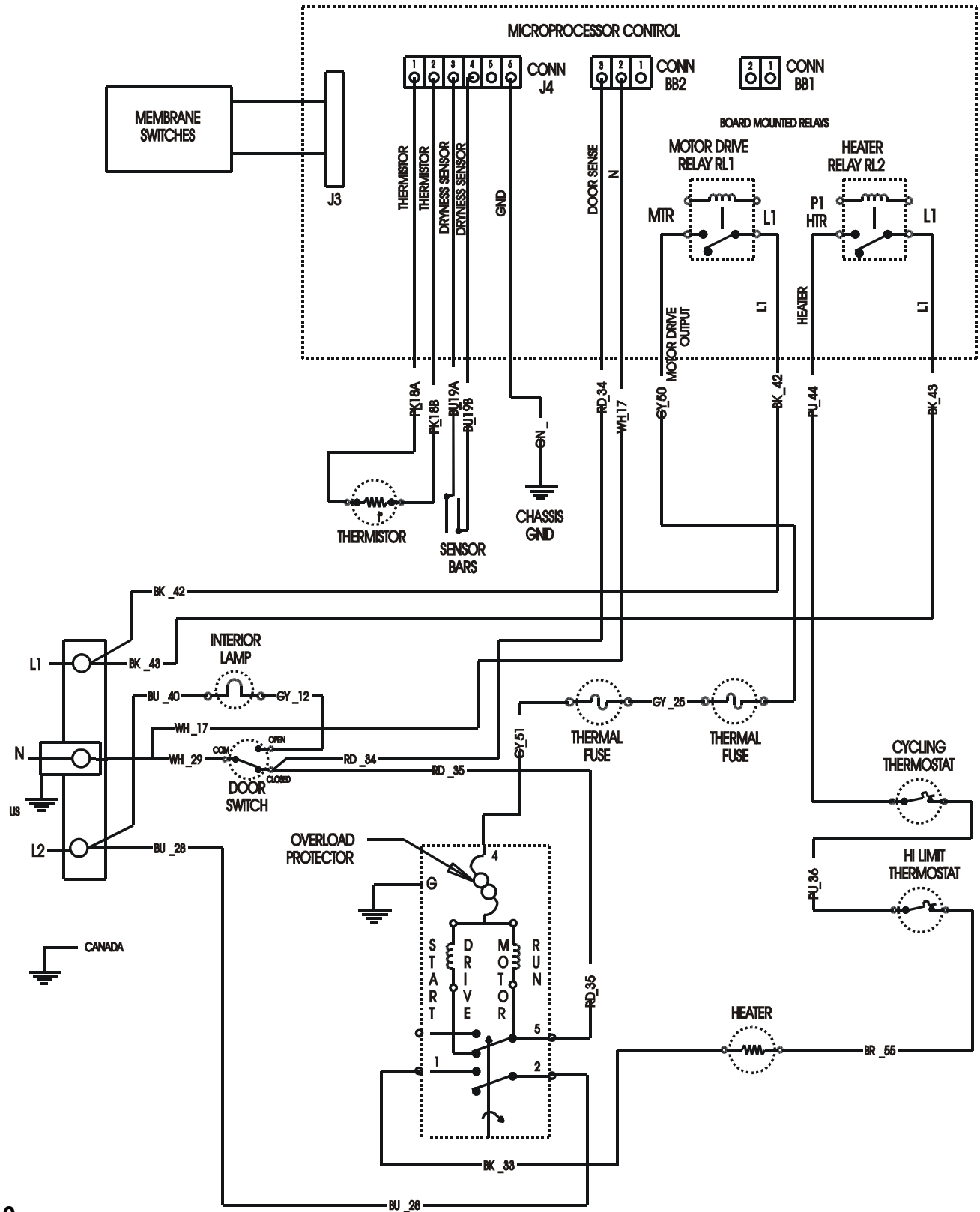

16023110

MDG6800

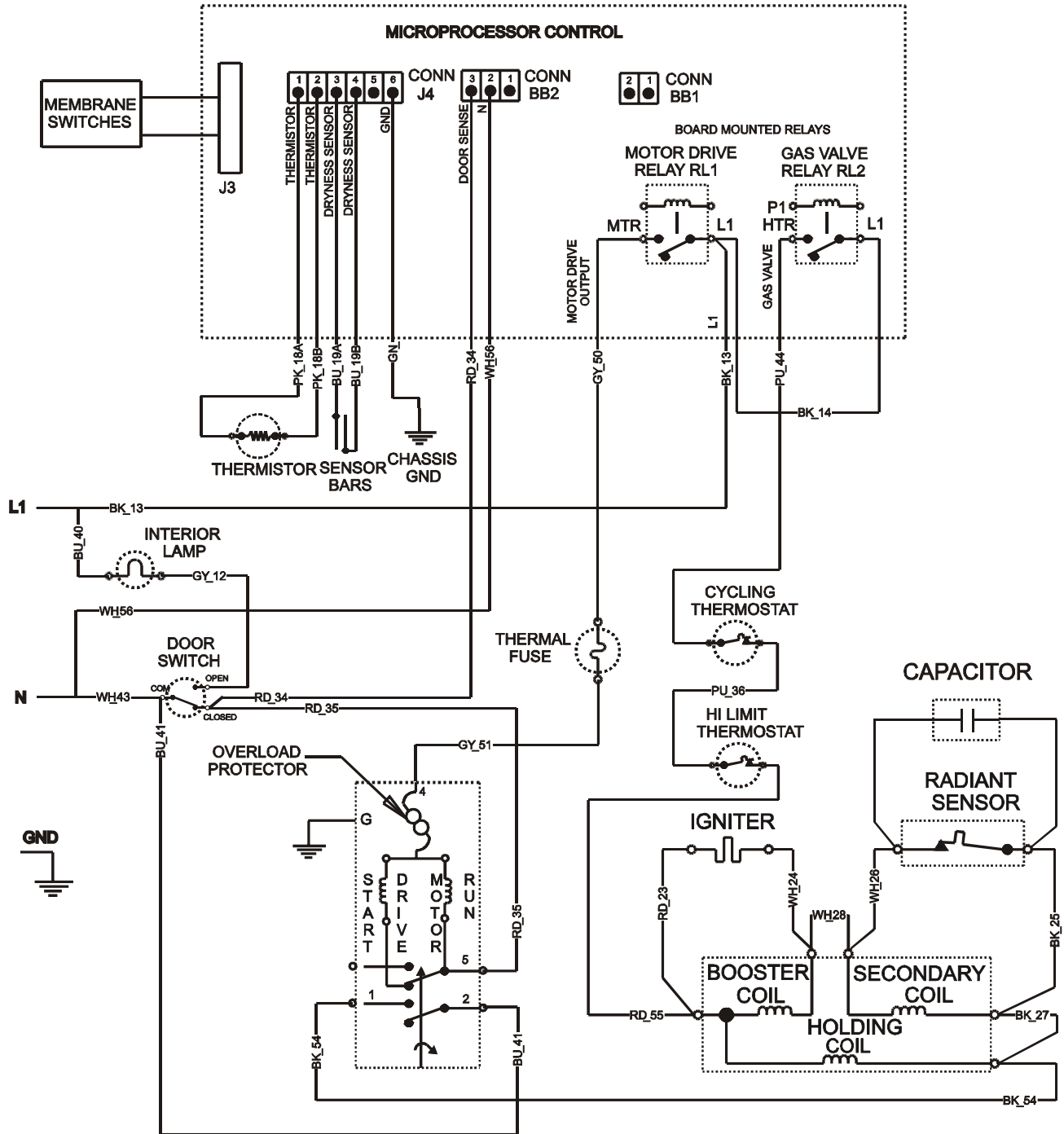

MDE9800

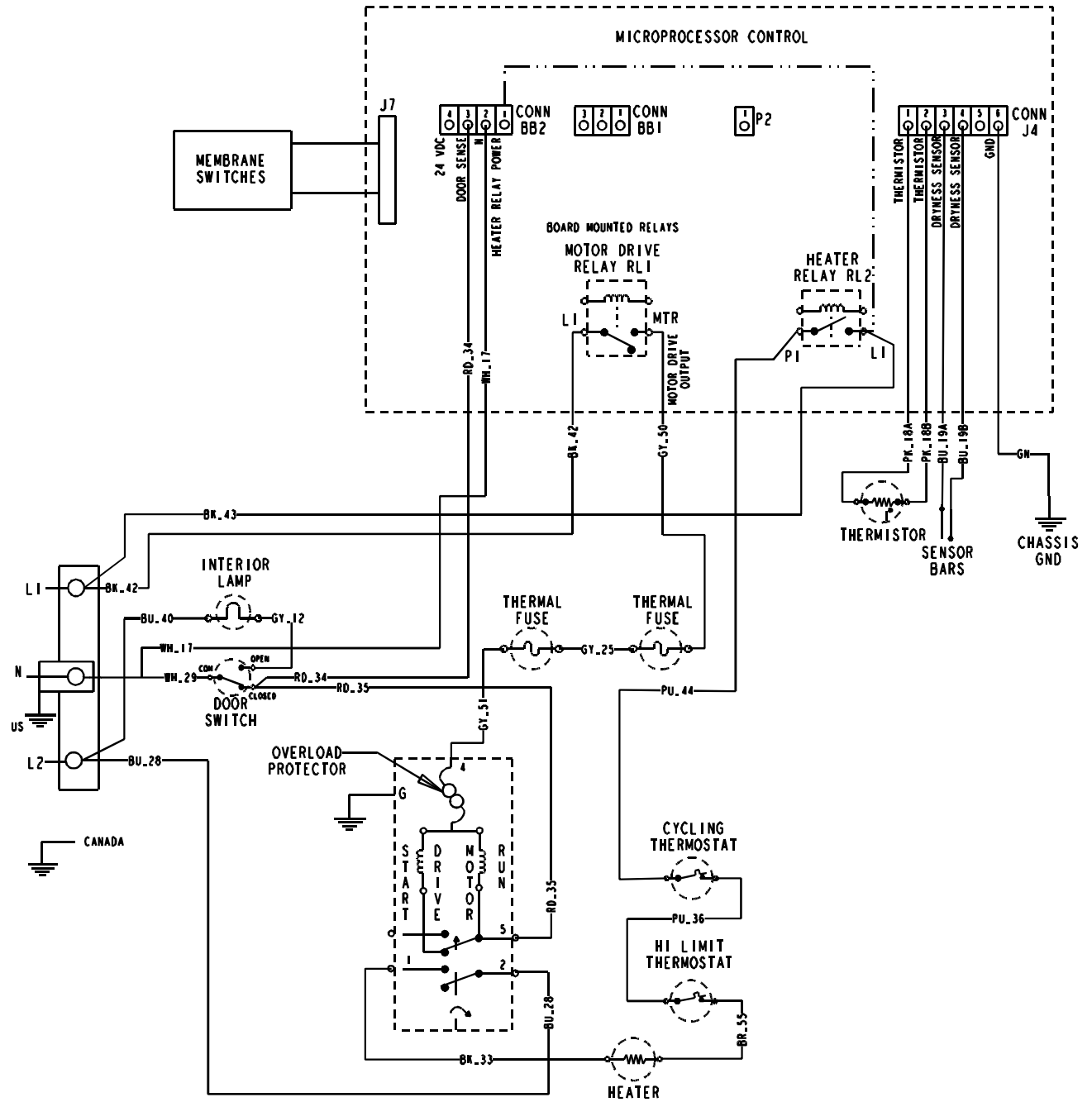

MDG9800

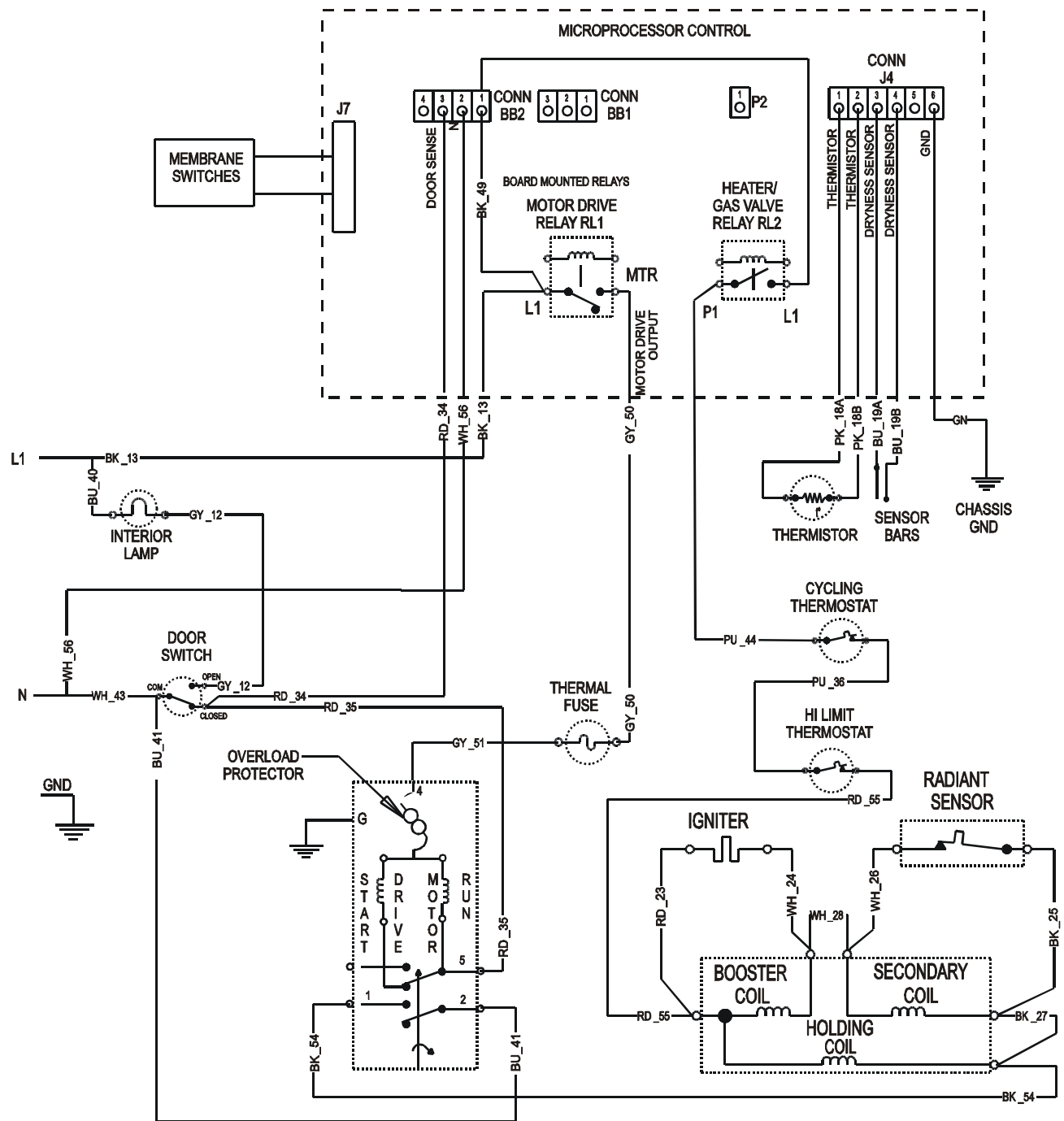

MAYTAG

Maytag Appliances Sales Company

Customer Service
240 Edwards St.
Cleveland, TN 37311