





Fast Track Troubleshooting

Models: DV203***
DV206* DV209*****
DV218* DV219*****
DV306* DV316*****
DV317* DV326*****
DV328* DV337*****
DV338* DV3C6*****

IMPORTANT SAFETY NOTICE – “For Technicians Only” This service data sheet is intended for use by persons having electrical, electronic, and mechanical experience and knowledge at a level generally considered acceptable in the appliance repair trade. Any attempt to repair a major appliance may result in personal injury and property damage. The manufacturer or seller cannot be responsible, nor assume any liability for injury or damage of any kind arising from the use of this data sheet.

Publication # tsDV203 Creation Date 1/22/2010

Samsung 'Dryer' Diagnostic Code Quick Guide

Display	Description	Trigger	Action Taken
	Dryer Thermistor Short Sensed	The Thermistor resistance is very low.	Check for: Clogged lint screen, Restricted vent system, Thermistor resistance.
	Dryer Thermistor Open Sensed	The Thermistor resistance is very high.	Check for: Clogged lint screen, Restricted vent system, Thermistor resistance.
do	Door Open	Running the dryer with door open	Check for: Loose or open wire terminals in Door Sense circuit.
FE	Power source frequency Error	Invalid power source Frequency	Check for: Non Utility power supply
dF	Door Circuit Failure	Invalid state for more than 256 milliseconds	Check for: Loose or open wire terminals in Door Sense circuit.
hE or HE	Heater Error	Invalid heating Temp in running the dryer	Check for: Restricted vent system, Thermistor resistance.
bE	Button Error	PCB key closed for 75 sec.	Check Display PCB for stuck button

TOUCH UP PAINT, BLUE ONYX	DH81-11980A
TOUCH UP PAINT, IMPERIAL SILVER	DH81-11981A
TOUCH UP PAINT, NEAT WHITE	DH81-11982A
TOUCH UP PAINT, STRATUS GRAY	DH81-11983A
TOUCH UP PAINT, TANGO RED	DH81-11984A

Electrical Dryers 240 VAC, 60 Hz, 30 Amps, 3-wire or 4-wire installations

Gas Dryers 120 VAC, 60 Hz, 15 Amps, 3-wire installations

Do not use dryer to dry clothes which have traces of any flammable substance, such as vegetable oil, cooking oil, machine oil, flammable chemicals, thinner, etc., or anything containing wax or chemicals, such as mops and cleaning cloths. Flammable substances may cause fabric to catch fire by itself.

Location consideration In the USA:

- All Dryers Must be vented to the outside.
- Only rigid or flexible metal duct should be used for venting.

GAS DRYER WIRING DIAGRAM

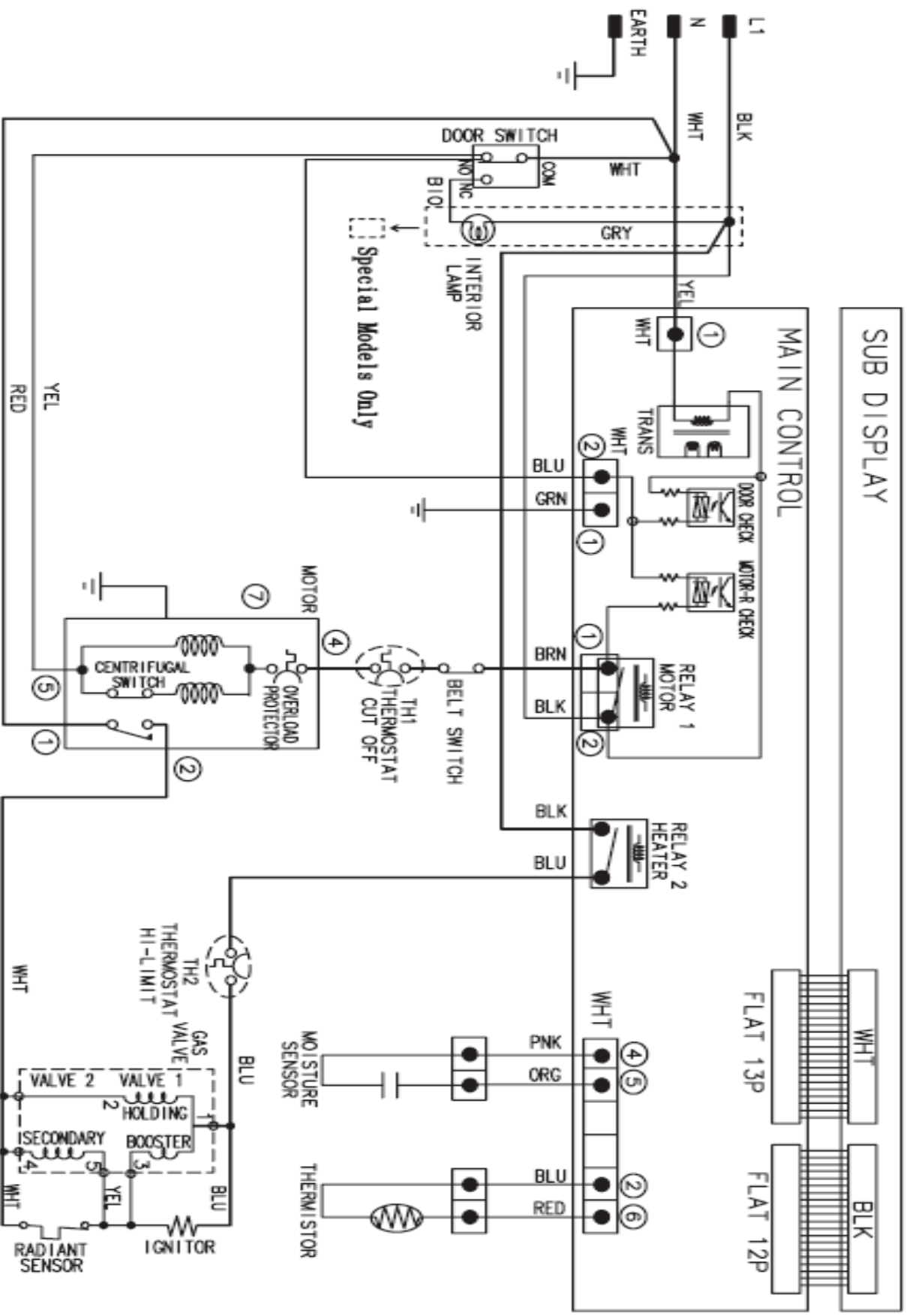

DC68-02319A

ELECTRIC DRYER WIRING DIAGRAM

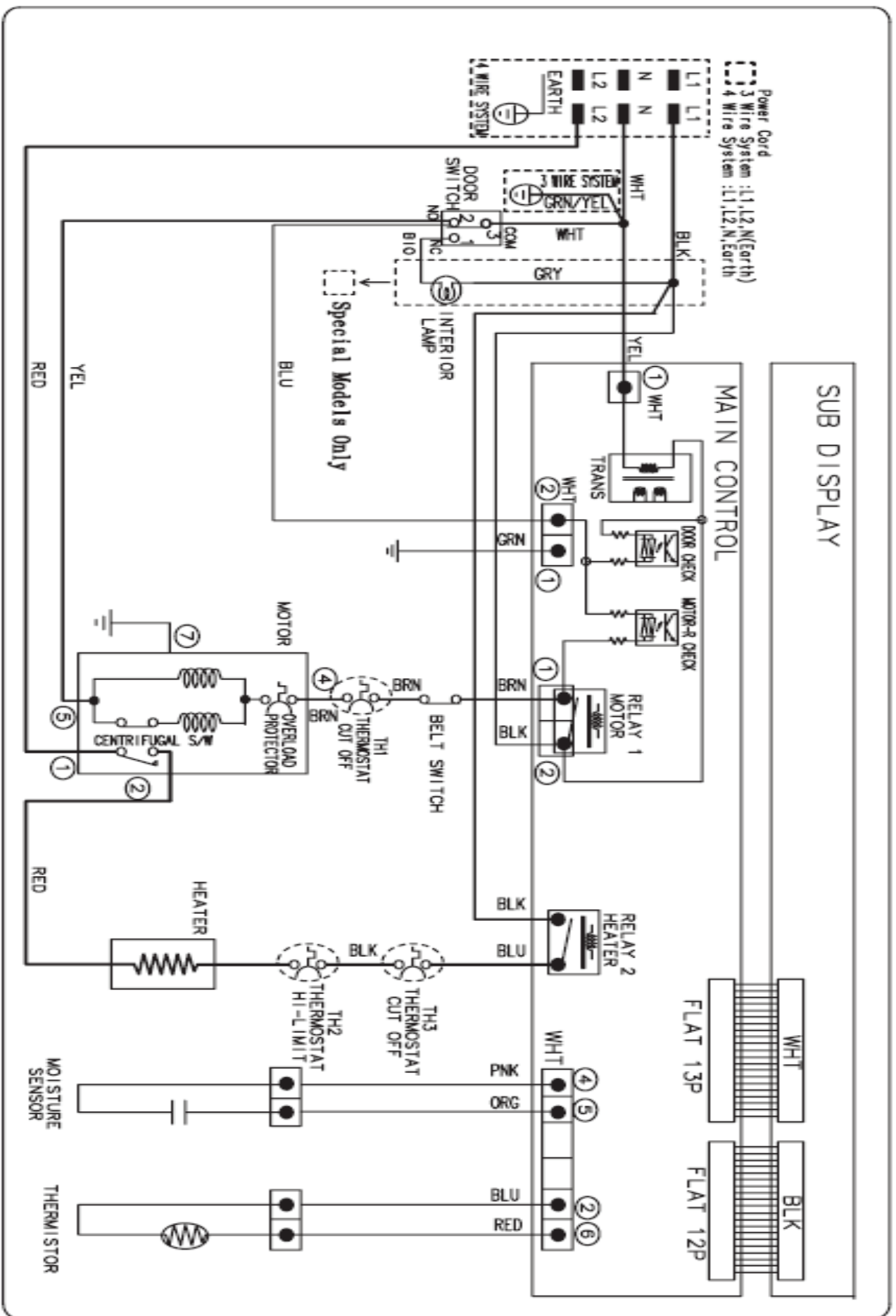

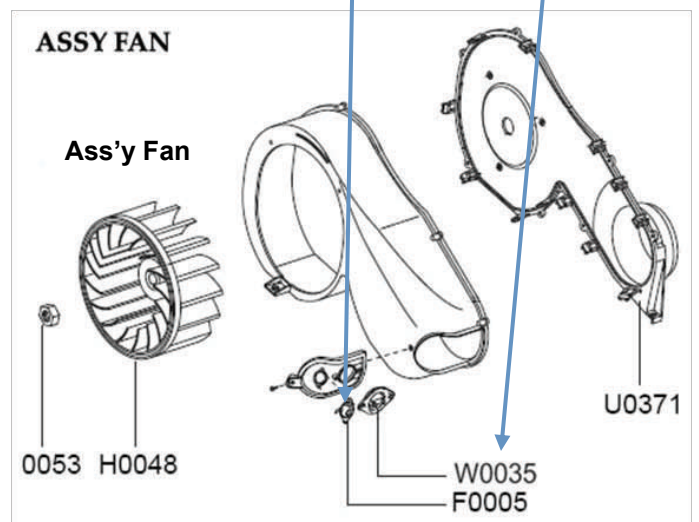
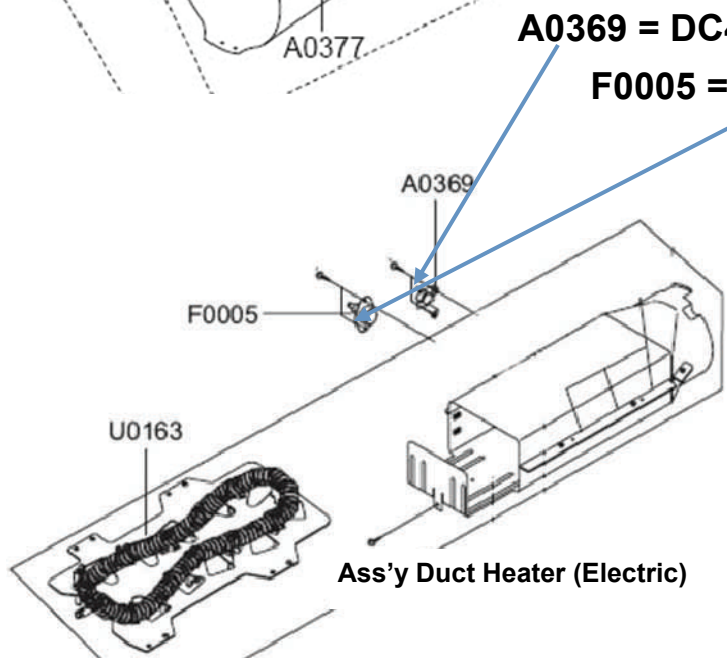
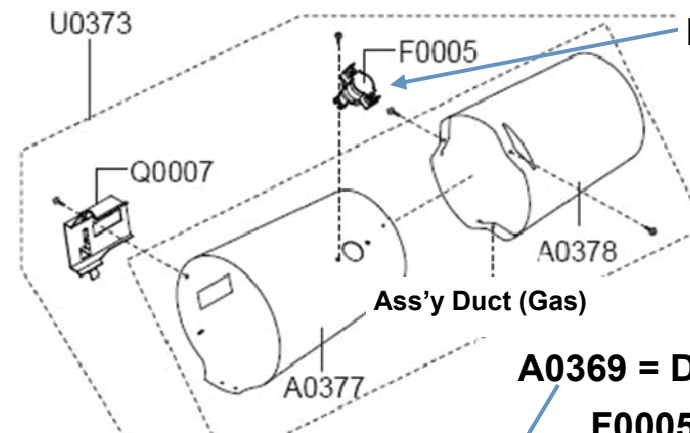
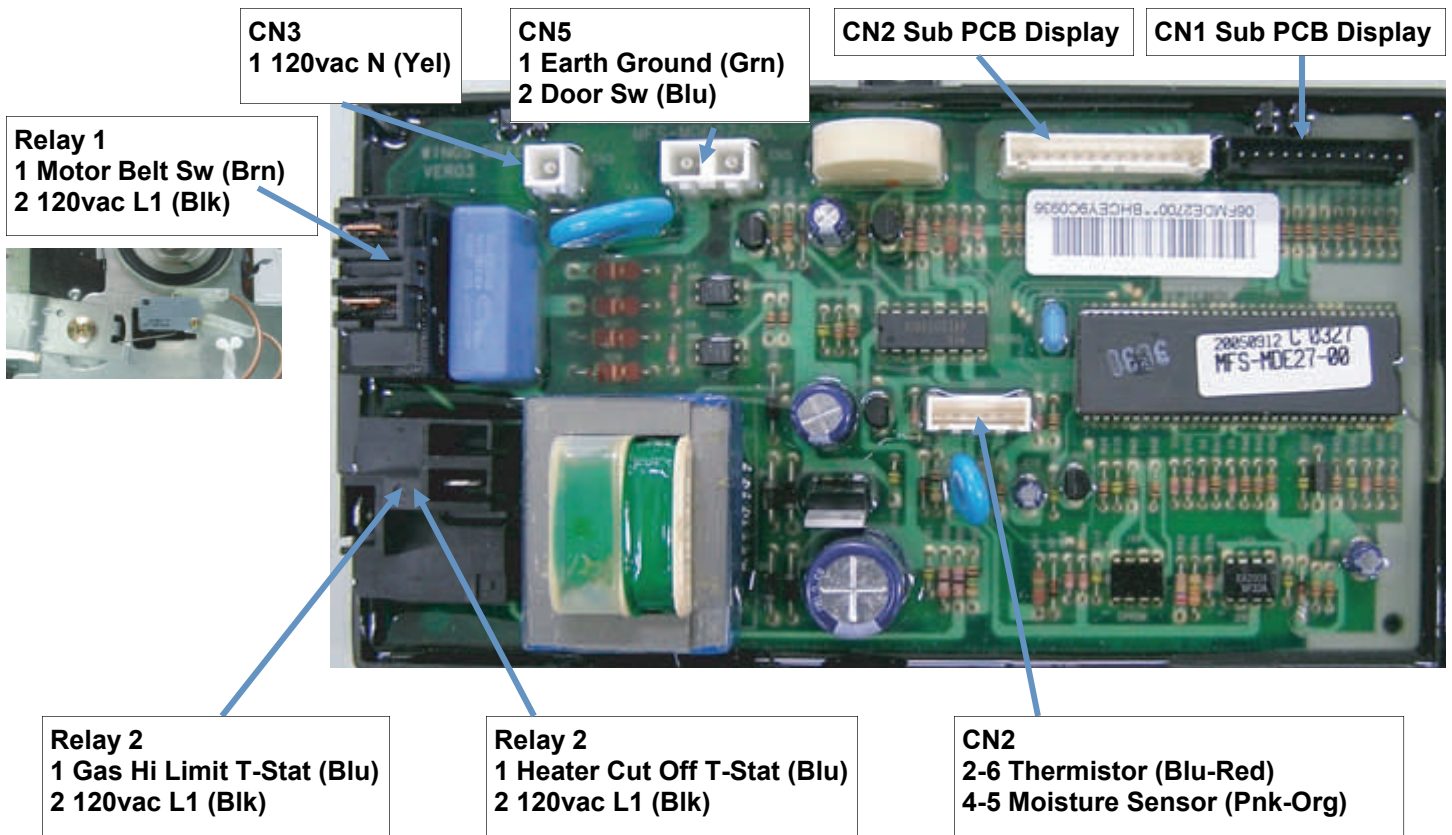

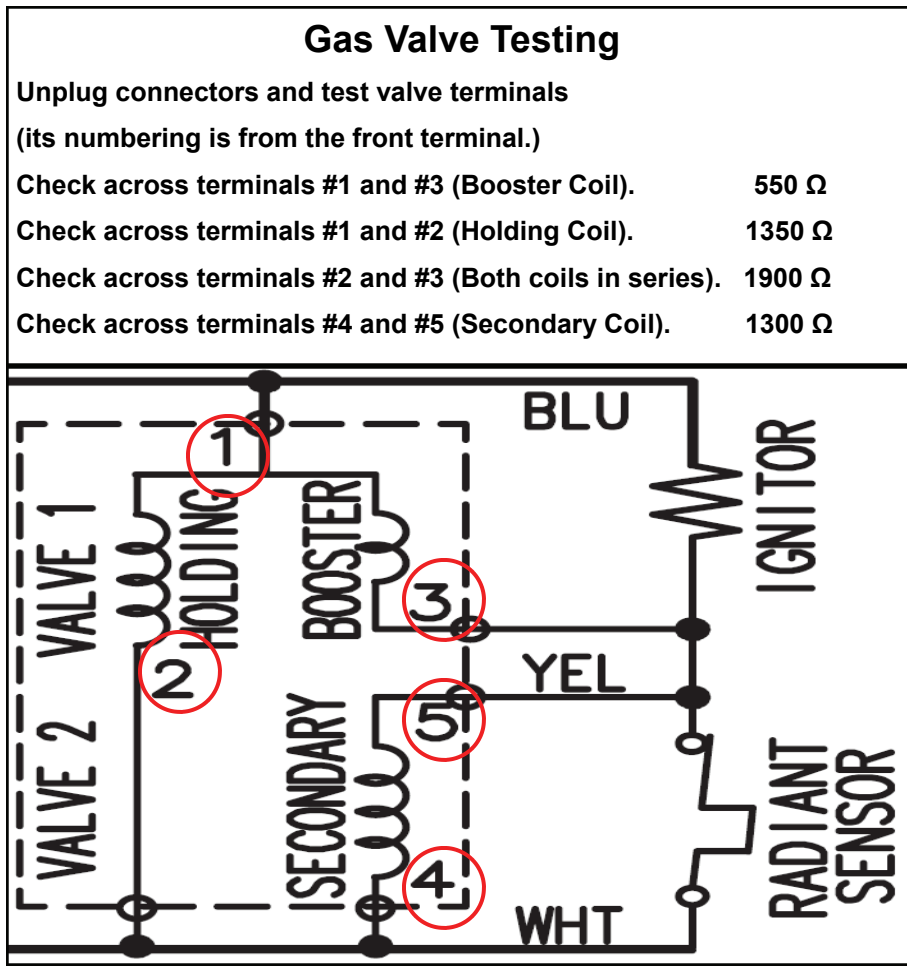

Cycle Count Test Mode

How to Enter:
Press Signal + Wrinkle Prevent Keys for 3 sec during Power On State.
Press Signal key for 3 seconds (until beep)
Note: Test mode subject to change without notice

Sensor Bar Touch Data Mode

How to Enter:
Start Dryer tumbling, Press Temp + Signal for 3 seconds during the drying process.
Open door, touch both sensor bars with wet cloth, sensor hit numbers show in display.
Note: Test mode subject to change without notice

Temperature Test Diagnostic Mode

How to Enter:
Press Signal + Wrinkle Prevent Keys for 3 sec during Power On State.
Press Time + Wrinkle Prevent Keys and 7-segment will display the temperature in Celsius.
Compare vent temp to drum temp to see air flow.

Software Version Test Mode

How to Enter:
Press Signal + Wrinkle Prevent Keys for 3 sec during Power On State.
Press Temp key for 3 seconds (until beep)
Note: Test mode subject to change without notice

Special Test Mode:

- While in Power Off, pressing the Dryness Level + Power keys simultaneously will put the dryer into the System Check mode
- "t2" will display.
- System Check Mode Progress
- t2 mode Function Performed Start/Pause Motor(CW) Relay On → Heater Relay On → Heater Relay Off → Motor (CW) Relay Off (Circulation)

Caution! Do not give it too much testing time. It will over-burden the Main PCB.

Dryer continues to run after cycle completed

Wrinkle Prevent option provides approximately 90 minutes of intermittent tumbling in unheated air at the end of the cycle to reduce wrinkling. Press the Wrinkle Prevent button to activate this feature. The indicator light above the pad will illuminate when Wrinkle Prevent is selected. Chasing lights appear in the display when the Wrinkle Prevent option is selected. The load is dry, and can be removed at any time during the Wrinkle Prevent cycle.

Thermistor

Temp F°	Ω
50	20KΩ
60	15.8KΩ
77	10KΩ
85	8KΩ
95	6.5KΩ
115	4.3KΩ
140	2.5KΩ
160	1.7KΩ
175	1.3KΩ
200	850Ω

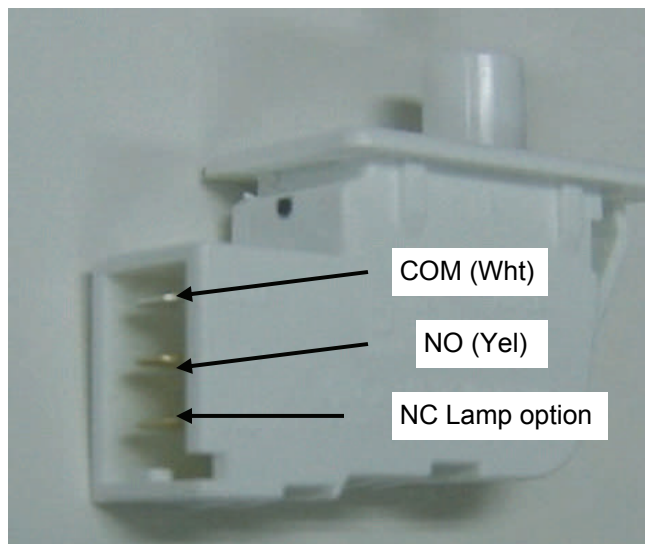

ELECTRIC AND GAS DRYER				
Weather Hood Type				
Recommended			Use only for short-run installation	
4" (10.16 cm)			2.5" (6.35 cm)	
No. of 90° elbows	Rigid	Metallic Flexible*	Rigid	Metallic Flexible*
0	24.4 m (80 ft.)	12.4 m (41 ft.)	22.6 m (74 ft.)	10.1 m (33 ft.)
1	20.7 m (68 ft.)	11.2 m (37 ft.)	18.9 m (62 ft.)	8.8 m (29 ft.)
2	17.4 m (57 ft.)	10.1 m (33 ft.)	15.5 m (51 ft.)	7.6 m (25 ft.)
3	14.3 m (47 ft.)	9.0 m (29 ft.)	12.5 m (41 ft.)	6.5 m (21 ft.)

* Do not use non-metallic flexible duct.