









Fast Track Troubleshooting

Models: DV338***
 DV339*** DV407***
 DV409*** DV419***
 DV438*** DV448***

IMPORTANT SAFETY NOTICE – “For Technicians Only” This service data sheet is intended for use by persons having electrical, electronic, and mechanical experience and knowledge at a level generally considered acceptable in the appliance repair trade. Any attempt to repair a major appliance may result in personal injury and property damage. The manufacturer or seller cannot be responsible, nor assume any liability for injury or damage of any kind arising from the use of this data sheet.

Publication # **tsDV407** Creation Date 1/22/2010

Samsung 'Dryer' Diagnostic Code Quick Guide

Display	Description	Trigger	Action Taken
	Dryer Thermistor Short Sensed	The Thermistor resistance is very low.	Check for: Clogged lint screen, Restricted vent system, Thermistor resistance.
	Dryer Thermistor Open Sensed	The Thermistor resistance is very high.	Check for: Clogged lint screen, Restricted vent system, Thermistor resistance.
do	 Door Open	Running the dryer with door open	Check for: Loose or open wire terminals in Door Sense circuit.
FE	 Power source frequency Error	Invalid power source Frequency	Check for: Non Utility power supply
dF	 Door Circuit Failure	Invalid state for more than 256 milliseconds	Check for: Loose or open wire terminals in Door Sense circuit.
hE or HE	 Heater Error	Invalid heating Temp in running the dryer	Check for: Restricted vent system, Thermistor resistance.
bE	 Button Error	PCB key closed for 75 sec.	Check Display PCB for stuck button

ELECTRIC AND GAS DRYER

Weather Hood Type

Recommended

Use only for short-run installation



4" (10.16 cm)

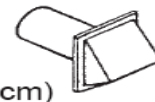

2.5" (6.35 cm)

No. of 90° elbows	Recommended		Use only for short-run installation	
	Rigid	Metallic Flexible*	Rigid	Metallic Flexible*
0	24.4 m (80 ft.)	12.4 m (41 ft.)	22.6 m (74 ft.)	10.1 m (33 ft.)
1	20.7 m (68 ft.)	11.2 m (37 ft.)	18.9 m (62 ft.)	8.8 m (29 ft.)
2	17.4 m (57 ft.)	10.1 m (33 ft.)	15.5 m (51 ft.)	7.6 m (25 ft.)
3	14.3m (47 ft.)	9.0 m (29 ft.)	12.5 m (41 ft.)	6.5 m (21 ft.)

* Do not use non-metallic flexible duct.

GAS DRYER WIRING DIAGRAM

SUB DISPLAY

MAIN PCB CONTROL

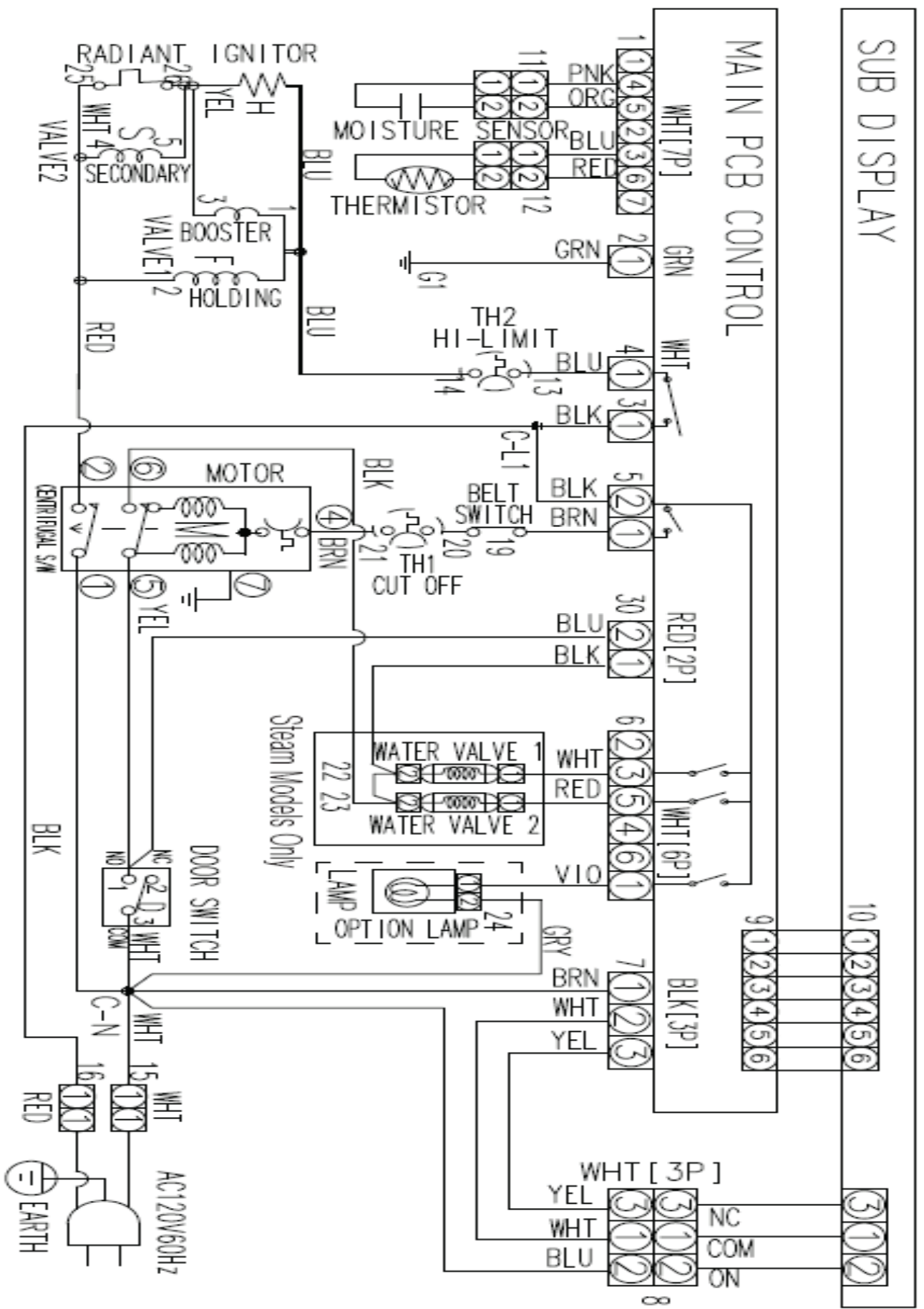

ELECTRIC DRYER WIRING DIAGRAM

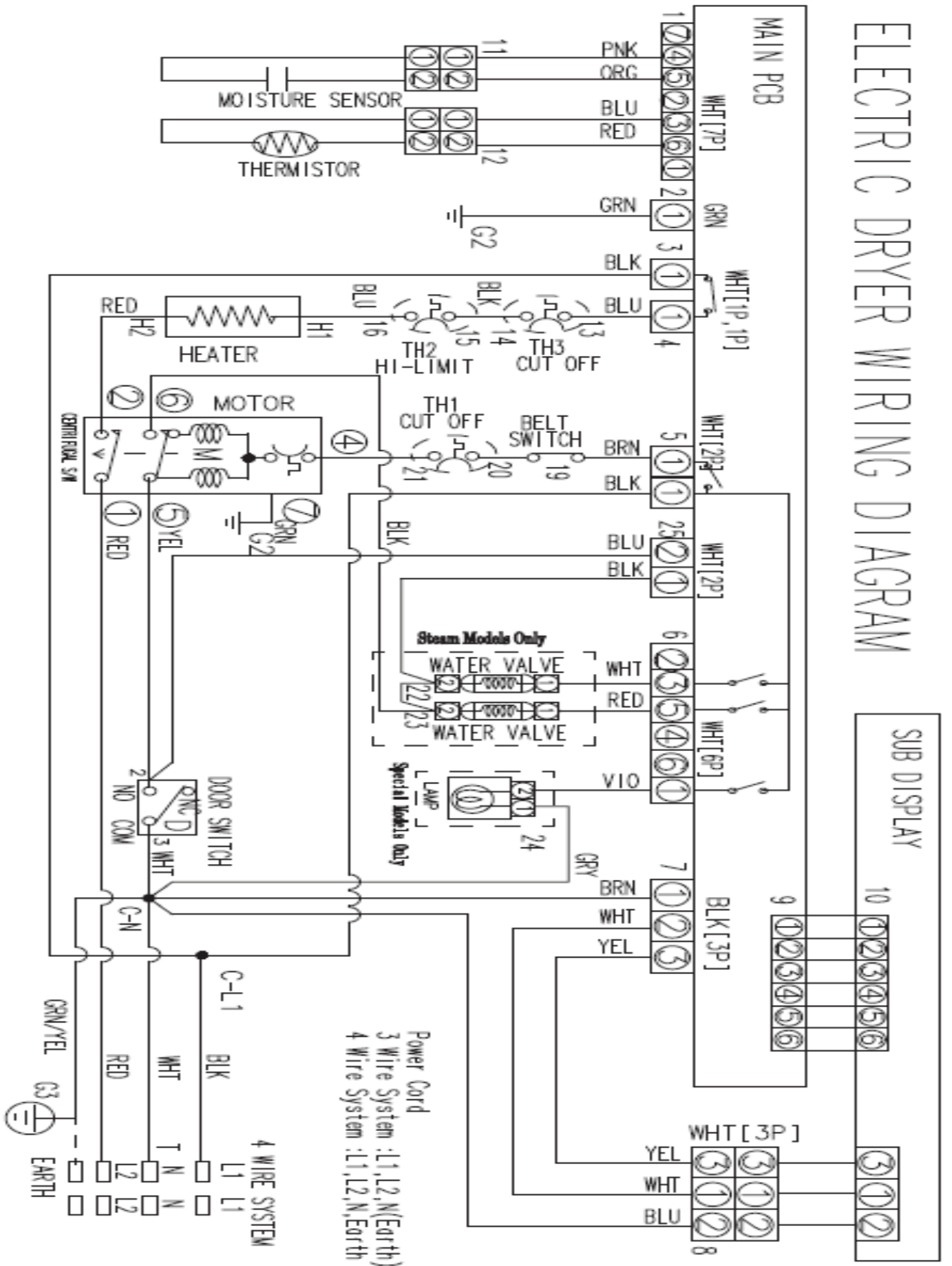

CN1
 1 120vac N (Brn)
 2 Sub PCB (Wht)
 3 Sub PCB (Yel)

CN7
 1 Water Valve (Blk)
 2 Door Sw (Blu)

CN2 Sub PCB Display

CN2
 3-6 Thermistor (Blu-Red)
 4-5 Moisture Sensor (Pnk-Org)



Relay 1
 1 Motor Belt Sw (Brn)
 2 120vac L1 (Blk)

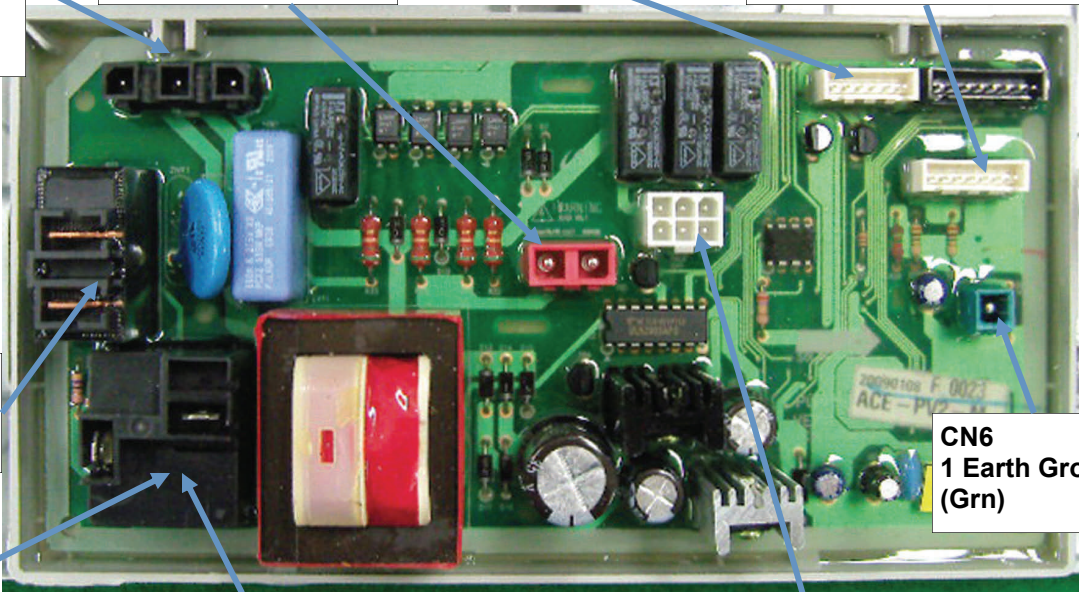

CN6
 1 Earth Ground (Grn)

Relay 6
 1 Gas Hi Limit T-Stat (Blu)
 2 120vac L1 (Blk)

Relay 6
 1 Heater Cut Off T-Stat (Blu)
 2 120vac L1 (Blk)

CN5
 1 Lamp (Vio)
 3 Water Valve (Wht)
 5 Water Valve (Red)

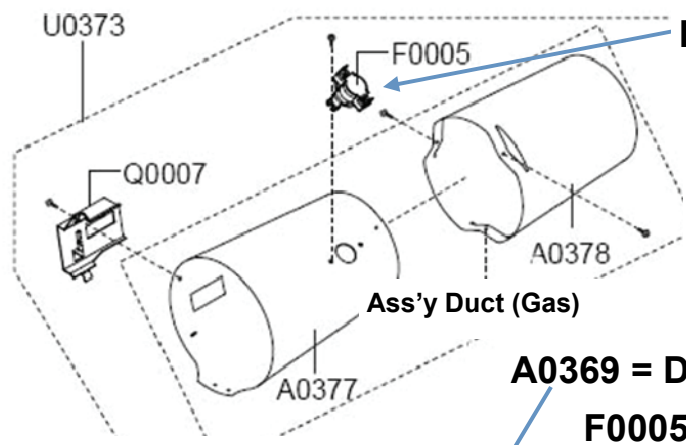

F0005 = DC47-00017A

Thermistor W0035 = DC32-00007A
F0005 = DC47-00016A

A0369 = DC47-00015A

F0005 = DC47-00018A

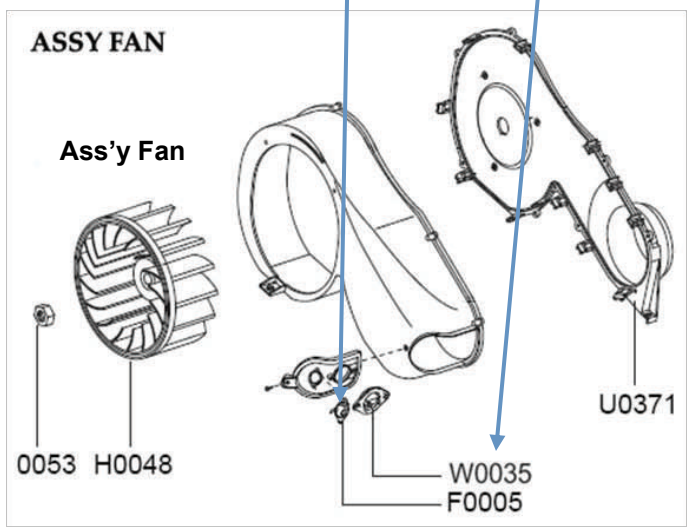
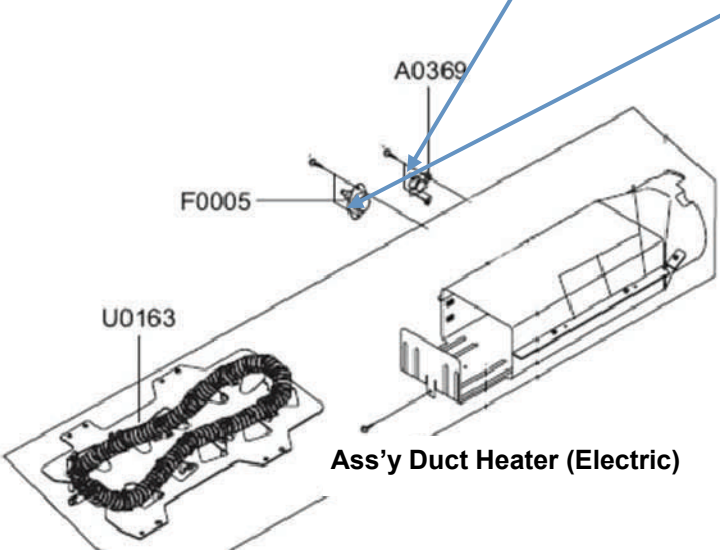

Thermistor

Temp F ^o	Ω
50	20KΩ
60	15.8KΩ
77	10KΩ
85	8KΩ
95	6.5KΩ
115	4.3KΩ
140	2.5KΩ
160	1.7KΩ
175	1.3KΩ
200	850Ω

Dryer continues to run after cycle completed

Wrinkle Prevent option provides approximately 90 minutes of intermittent tumbling in unheated air at the end of the cycle to reduce wrinkling.

Press the Wrinkle Prevent button to activate this feature.

The indicator light above the pad will illuminate when Wrinkle Prevent is selected.

Chasing lights appear in the display when the Wrinkle Prevent option is selected. The load is dry, and can be removed at any time during the Wrinkle Prevent cycle.

Electrical Dryers 240 VAC, 60 Hz, 30 Amps, 3-wire or 4-wire installations

Gas Dryers 120 VAC, 60 Hz, 15 Amps, 3-wire installations

Special Test Mode:

While in Power Off, pressing the Dryness Level + Power keys simultaneously will put the dryer into the System Check mode "t2" will display.

System Check Mode Progress

t2 mode Function Performed Start/Pause Motor(CW) Relay On → Heater Relay On → Heater Relay Off → Motor(CW) Relay Off (Circulation)

Caution! Do not give it too much testing time. It will over-burden the Main PCB.

Sensor Bar Touch Data Mode

How to Enter:

Start Dryer tumbling, Press Temp + Signal for 3 seconds during the drying process.

Open door, touch both sensor bars with wet cloth, sensor hit numbers show in display.

Note: Test mode subject to change without notice

Cycle Count Test Mode

How to Enter:

Press Signal + Wrinkle Prevent Keys for 3 sec during Power On State.

Press Signal key for 3 seconds (until beep)

Note: Test mode subject to change without notice

Software Version Test Mode

How to Enter:

Press Signal + Wrinkle Prevent Keys for 3 sec during Power On State.

Press Temp key for 3 seconds (until beep)

Note: Test mode subject to change without notice

Door Switch

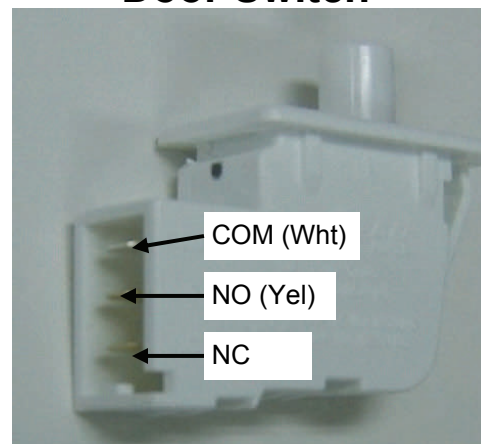

Temperature Test Diagnostic Mode

How to Enter:

Press Signal + Wrinkle Prevent Keys for 3 sec during Power On State.

Press Time + Wrinkle Prevent Keys and 7-segment will display the temperature in Celsius.

Compare vent temp to drum temp to see air flow.

Location consideration In the USA:

- All Dryers Must be vented to the outside.
- Only rigid or flexible metal duct should be used for venting.

Do not use dryer to dry clothes which have traces of any flammable substance, such as vegetable oil, cooking oil, machine oil, flammable chemicals, thinner, etc., or anything containing wax or chemicals, such as mops and cleaning cloths. Flammable substances may cause fabric to catch fire by itself.

Testing Steam Cycle:

Select Wrinkle Care cycle for 4 minutes, check for heat and moisture. If both are present, the dryer is working properly

Time and Control Temp.																
time	1st Heating Resign			1 Spray Resign			2nd Heating Resign			2nd Spray Resign			3rd Heating Resign			Cooling resign
	Time	Control Temp.		Time	Control Temp.		Time	Control Temp.		Time	Control Temp.		Time	Control Temp.		Time
		Heat er Off	Heat er On		Heat er Off	Heat er On		Heat er Off	Heat er On		Heat er Off	Heat er On		Heat er Off	Heat er On	
20 min	1min.	58°C	50°C	1min.	58°C	50°C	1min.	58°C	50°C	1min.	58°C	50°C	13min.	58°C	50°C	3min.



Major Dryer Spray Components



Gas Valve Testing

Unplug connectors and test valve terminals (its numbering is from the front terminal.)

Check across terminals #1 and #3 (Booster Coil).	550 Ω
Check across terminals #1 and #2 (Holding Coil).	1350 Ω
Check across terminals #2 and #3 (Both coils in series).	1900 Ω
Check across terminals #4 and #5 (Secondary Coil).	1300 Ω

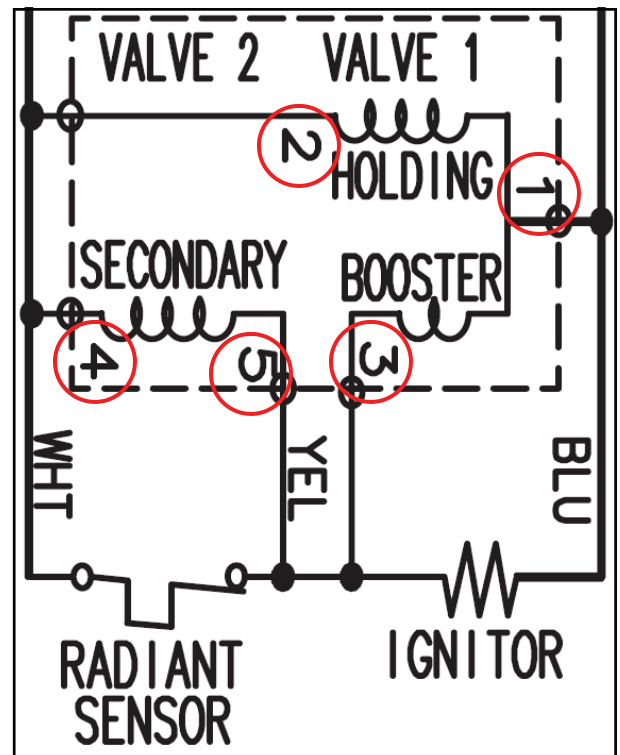

Laundry Touch Up Paints

TOUCH UP PAINT, BLUE ONYX	DH81-11980A
TOUCH UP PAINT, IMPERIAL SILVER	DH81-11981A
TOUCH UP PAINT, NEAT WHITE	DH81-11982A
TOUCH UP PAINT, STRATUS GRAY	DH81-11983A
TOUCH UP PAINT, TANGO RED	DH81-11984A