

KitchenAid

TECHNICAL EDUCATION



FRONT-LOADING GAS AND ELECTRIC DRYERS



MODELS: KGHS01PMT / WH & KEHS01PMT / WH

JOB AID 4317356

FORWARD

This KitchenAid Job Aid, “Ensemble™ Front-Loading Gas and Electric Dryers,” (Part No. 4317356), provides the technician with information on the installation, operation, and service of the Ensemble™ Front-Loading Gas and Electric Dryers. It is to be used as a training Job Aid and Service Manual. For specific information on the model being serviced, refer to the “Use and Care Guide,” or “Tech Sheet” provided with the dryer.

The Wiring Diagrams used in this Job Aid are typical and should be used for training purposes only. Always use the Wiring Diagram supplied with the product when servicing the unit.

GOALS AND OBJECTIVES

The goal of this Job Aid is to provide detailed information that will enable the service technician to properly diagnose malfunctions and repair the KitchenAid Ensemble™ Front-Loading Gas and Electric Dryers.

The objectives of this Job Aid are to:

- Understand and follow proper safety precautions.
- Successfully troubleshoot and diagnose malfunctions.
- Successfully perform necessary repairs.
- Successfully return the Gas or Electric Dryer to its proper operational status.

WHIRLPOOL CORPORATION assumes no responsibility for any repairs made on our products by anyone other than Authorized Service Technicians.

TABLE OF CONTENTS

Page

GENERAL	1-1
Safety First	1-1
Model & Serial Number Designations	1-2
Model & Serial Number Label And Tech Sheet Locations	1-3
Specifications	1-4
KitchenAid Dryer Warranty	1-5
Pedestal Warranty.....	1-6
INSTALLATION INFORMATION	2-1
Installation Instructions	2-1
Installing The Dryer On The Pedestal	2-23
PRODUCT OPERATION	3-1
COMPONENT ACCESS	4-1
Component Locations	4-1
Removing The Electronic Control Board	4-2
Removing The Console & The Touchpad Subassembly	4-4
Removing The Door Switch	4-6
Removing The Thermal Fuse, Thermistor, Drive Motor, & Belt Switch	4-7
Removing The Heater, The High-Limit Thermostat, & Thermal Cutoff (Electric Dryers Only)	4-10
Removing The Belt, Drum, & Rollers	4-12
Removing The Drum Light Socket	4-15
Removing The Moisture Sensor	4-17
Removing The Burner Assembly, Flame Sensor, And High-Limit Thermostat (Gas Dryers Only)	4-18
COMPONENT TESTING	5-1
Heater	5-1
Drive Motor.....	5-2
Thermal Fuse	5-3
Thermistor	5-4
Thermal Cutoff (Electric Dryers Only)	5-5
Door Switch	5-6
Gas Burner Coils	5-7
Burner Ignitor	5-7
Flame Sensor	5-8
High-Limit Thermostat	5-8
DIAGNOSTICS AND TROUBLESHOOTING	6-1
Diagnostics.....	6-1
Diagnostic Guide	6-1
Display Fault/Error Codes	6-2
Diagnostic Tests	6-2
Troubleshooting	6-4
Troubleshooting Guide	6-4
Troubleshooting Tests.....	6-4
WIRING DIAGRAMS	7-1
Electric Dryer.....	7-1
Gas Dryer	7-1

— NOTES —

GENERAL SAFETY FIRST

Your safety and the safety of others is very important.

We have provided many important safety messages in this Job Aid and on the appliance. Always read and obey all safety messages.



This is the safety alert symbol.

This symbol alerts you to hazards that can kill or hurt you and others.

All safety messages will follow the safety alert symbol and either the word “DANGER” or “WARNING.” These words mean:

! DANGER

You can be killed or seriously injured if you don't immediately follow instructions.

! WARNING

You can be killed or seriously injured if you don't follow instructions.

All safety messages will tell you what the potential hazard is, tell you how to reduce the chance of injury, and tell you what can happen if the instructions are not followed.

MODEL & SERIAL NUMBER DESIGNATIONS

MODEL NUMBER (DRYER)

MODEL NUMBER	K	G	H	S	01	P	MT	0
PRODUCT GROUP K = KITCHENAID								
PRODUCT IDENTIFICATION G = GAS E = ELECTRIC								
FEATURE CODE H = HORIZONTAL								
FEATURE CODE S = SUPERBA								
SERIES								
YEAR OF INTRODUCTION P = 2004								
COLOR CODE MT = METEORITE, WH = WHITE								
ENGINEERING CHANGE (NUMERIC)								

MODEL NUMBER (PEDESTAL)

MODEL NUMBER	L	A	B	27	0	0	P	MT	0
PRODUCT GROUP L = Domestic Laundry									
PRODUCT IDENTIFICATION A = Laundry Accessory									
FEATURE CODE B = Pedestal Base									
PRODUCT WIDTH									
FILLER									
FILLER									
YEAR OF INTRODUCTION									
COLOR CODE MT = Meteorite, Q = White									
ENGINEERING CHANGE									

SERIAL NUMBER (DRYER)

SERIAL NUMBER	M	P	46	01003
MANUFACTURING SITE MARION, OH				
YEAR OF PRODUCTION P = 2003				
WEEK OF PRODUCTION				
PRODUCT SEQUENCE NUMBER				

SERIAL NUMBER (PEDESTAL)

SERIAL NUMBER	C	P	01	10001
MANUFACTURING SITE C = CLYDE, OH				
YEAR OF PRODUCTION P = 2003				
WEEK OF PRODUCTION				
PRODUCT SEQUENCE NUMBER				

MODEL & SERIAL NUMBER LABEL AND TECH SHEET LOCATIONS

The Model/Serial Number label and Tech Sheet locations are shown below.

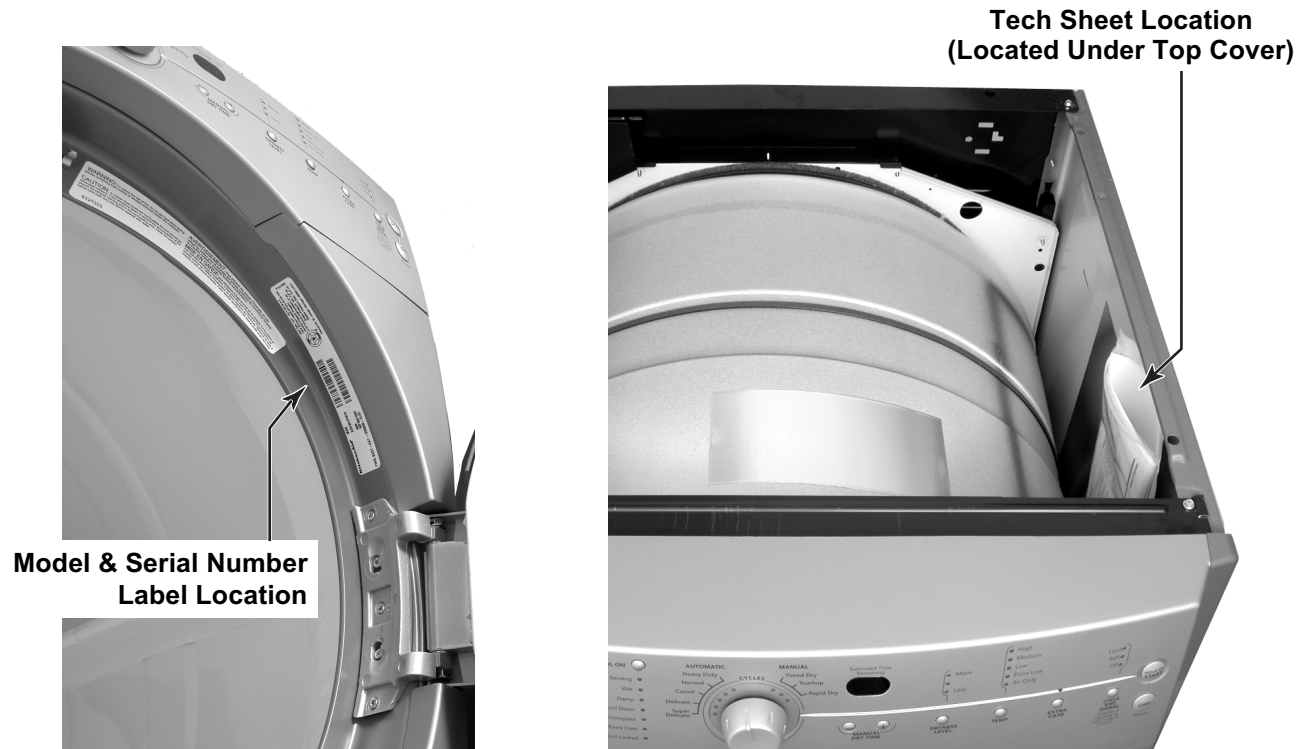

SPECIFICATIONS

BRAND	KitchenAid	KitchenAid
MODEL NUMBER	KEHS01PMT/WH	KGHS01PMT/WH
FUEL	Electric	Gas
CABINET COLOR	Meteorite/White	Meteorite/White
INSTALLATION OPTIONS		
FREESTANDING	X	X
PEDESTAL	X	X
STACKABLE	X	X
CAPACITY (cu ft)	7	7
CAPACITY NOMENCLATURE	SUPER CAPACITY	SUPER CAPACITY
AUTO CYCLE TERMINATION		
ENHANCED EH (Fuzzy Logic)	X	X
SENSEON CONTROL	X	X
LINT HANDLING		
FRONT SCREEN	X	X
CONTROLS	Electronic	Electronic
CONTROL LOCK OUT	X	X
CONTROL TYPE PRIMARY	Rotary	Rotary
CONTROL TYPE SECONDARY	Tap Touch	Tap Touch
NON-HEATED DRY RACK	X	X
MULTI-VENT OPTION	4 WAY	4 WAY
UTILITIES		
FREQUENCY	60HZ	60HZ
MOTOR RATING	1/3 HP	1/3 HP
HEATER ELEMENT	5400W	
GAS BTU		22000
RATED AMPERAGE (ELECTRIC)	28	
DIMENSIONS (UNCRATED)		
HEIGHT OF TOP	37.4" (95.0 cm)	37.4" (95.0 cm)
TOTAL HEIGHT	37.4" (95.0 cm)	37.4" (95.0 cm)
WIDTH	27" (68.5 cm)	27" (68.5 cm)
DEPTH		
ELECTRIC	30.75" (78 cm)	30.75" (78 cm)
GAS + 1 INCH	31.75" (80.6 cm)	31.75" (80.6 cm)
DEPTH DOOR OPEN	51" (129.5 cm)	51" (129.5 cm)
PRODUCT WEIGHT	143 lbs. (64.8 kg)	143 lbs. (64.8 kg)
WARRANTY		
LABOR	2 Years	2 Years
PARTS	2 Years	2 Years
PORCELAIN TOP	10 Years	10 Years
MOTOR/ELEMENT/BURNER	5 Years	5 Years
CONTROLS	5 Years	5 Years

KITCHENAID DRYER WARRANTY

TWO-YEAR FULL WARRANTY

For two years from the date of purchase, when this dryer is operated and maintained according to instructions attached to or furnished with the product, KitchenAid will pay for factory specified replacement parts and repair labor costs to correct defects in materials or workmanship. Service must be provided by a KitchenAid designated service company.

THIRD THROUGH FIFTH YEAR LIMITED WARRANTY ON ELECTRONIC CONTROL BOARDS, ELECTRICAL ELEMENT, GAS BURNER, MOTOR

For the third through fifth years from the date of purchase, when this dryer is operated and maintained according to instructions attached to or furnished with the product, KitchenAid will pay for factory specified replacement parts for the following components, if defective in materials or workmanship: any electrical element on electric models; the electronic control boards, any burner on gas models; replacement of the motor.

THIRD THROUGH TENTH YEAR LIMITED WARRANTY ON DRYER DRUM AND TOP/CABINET ASSEMBLY

For the third through tenth years from the date of purchase, when this dryer is operated and maintained according to instructions attached to or furnished with the product, KitchenAid will pay for factory specified replacement parts for the dryer drum and top/cabinet assembly should they rust due to defects in materials or workmanship.

KitchenAid will not pay for:

1. Service calls to correct the installation of your dryer, including venting. Heavy 4 in. (10.2 cm) metal exhaust vent must be used. Refer to the venting section of this manual and your Installation Instructions.
 2. Service calls to instruct you how to use your dryer, to replace house fuses or correct house wiring or reset circuit breakers, or to replace owner accessible light bulbs.
 3. Repairs when your dryer is used in other than normal, single-family household use.
 4. Damage resulting from accident, alteration, misuse, abuse, fire, floods, acts of God, improper installation (including, but not limited to, venting with plastic or flexible foil), installation not in accordance with local electrical and plumbing codes, or use of products not approved by KitchenAid.
 5. Replacement parts or repair labor costs for units operated outside the United States and Canada.
 6. Pickup and delivery. This product is designed to be repaired in the home.
 7. Repairs to parts or systems resulting from unauthorized modifications made to the appliance.
 8. In Canada, travel or transportation expenses for customers who reside in remote areas.
 9. Any labor costs incurred during the Limited Warranty periods.
-

KITCHENAID AND KITCHENAID CANADA SHALL NOT BE LIABLE FOR INCIDENTAL OR CONSEQUENTIAL DAMAGES.

Some states and provinces do not allow the exclusion or limitation of incidental or consequential damages, so this exclusion or limitation may not apply to you. This warranty gives you specific legal rights and you may also have other rights which vary from state to state or province to province.

Outside the 50 United States and Canada, this warranty does not apply. Contact your authorized KitchenAid dealer to determine if another warranty applies.

If you need service, first see "Troubleshooting" in the Use and Care Guide. Additional help can be found by checking "Assistance or Service" in the Use and Care Guide, or by calling our Customer Interaction Center at **1-800-422-1230**, from anywhere in the U.S.A. or write: KitchenAid Brand Home Appliances, Customer Interaction Center, 553 Benson Road, Benton Harbor, MI 49022-2400. In Canada, call KitchenAid Canada at **1-800-807-6777**.

PEDESTAL WARRANTY

FULL ONE YEAR WARRANTY ON MECHANICAL PARTS

For one year from the date of purchase, when this **Pedestal** is installed with the listed washer or dryer and operated according to the instructions provided in the washer or dryer Owner's Manual or Use and Care Guide, supplier will repair or replace any of its mechanical parts if defective in material or workmanship.

WARRANTY RESTRICTION

If the **Pedestal** is subject to other than private family use and or used with any other product than those listed in the installation instructions, the warranty is null and void.

INSTALLATION INFORMATION

INSTALLATION INSTRUCTIONS

TOOLS AND PARTS

Check that you have everything necessary for correct installation. Proper installation is your responsibility.

Assemble the required tools and parts before starting installation. Read and follow the instructions provided with any tools listed here.

- Caulking gun and compound (for installing new exhaust vent)
- Flat-blade screwdriver
- Adjustable wrench that opens to 1" (2.5 cm) or hex-head socket wrench (for adjusting dryer feet)
- Level
- Tin snips (new vent installations)
- 1/4" nut driver or socket wrench
- Vent clamps

Gas dryers only:

- 8" or 10" pipe wrench
- 8" or 10" adjustable wrench (for gas connections)
- Knife
- Pipe-joint compound resistant to L.P. gas
- Pliers

Electric dryers only:

- Wire stripper (direct wire installations)
- #2 phillips screwdriver

Parts supplied

Remove parts packages from dryer drum. Check that all parts are included.



4 Leveling legs

NOTE: Do not use leveling legs if installing the dryer on a pedestal.

Parts needed

Check local codes and with gas supplier. Check existing gas supply, electrical supply, and venting. Read "Electrical Requirements," "Gas Supply Requirements," and "Venting Requirements" before purchasing parts.

- For close-clearance installations between 31.5" (80.01 cm) and 37" (93.98 cm), see "Plan Vent System" section for venting requirements.

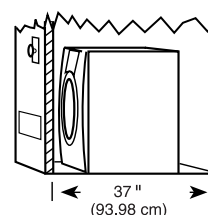

Mobile home installations require special parts (listed following) that may be ordered by calling the dealer from whom you purchased your dryer.

- Mobile Home Installation Kit, Part Number **346764**.
- Metal exhaust system hardware.

OPTIONAL PEDESTAL

A pedestal (**LAB2700PMT/LAB2700LQ**) may be purchased separately for this dryer. This pedestal will add about 13" (33 cm) to the height of the unit for a total vertical height of approximately 51" (130 cm).

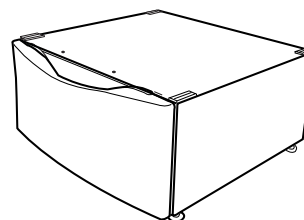

Optional pedestal

OPTIONAL STACK KIT

To stack your washer and dryer, you will need to purchase Stack Kit, Part Number **8541503**.

LOCATION REQUIREMENTS

⚠ WARNING



Explosion Hazard

Keep flammable materials and vapors, such as gasoline, away from dryer.

Place dryer at least 18 inches (46 cm) above the floor for a garage installation.

Failure to do so can result in death, explosion, or fire.

You will need

- A location that allows for proper exhaust installation. A gas dryer must be exhausted to the outdoors. See “Venting Requirements.”
- A separate 30 amp circuit (electric dryers only).
- A grounded electrical outlet located within 2 ft. (61 cm) of either side of the dryer. See “Electrical Requirements.”
- A sturdy floor to support the total dryer weight of 200 lbs. (90.7 kg). The combined weight of a companion appliance should also be considered.
- A level floor with a maximum slope of 1” (2.5 cm) under entire dryer. If slope is greater than 1” (2.5 cm), install Extended Dryer Feet Kit, Part Number **279810**. Clothes may not tumble properly and automatic sensor cycles may not operate correctly if dryer is not level.
- For a garage installation, you will need to place the dryer at least 18” (46 cm) above the floor. If using a pedestal, you will need an additional 6” (15.24 cm).

Do not operate your dryer at temperatures below 45°F (7°C). At lower temperatures, the dryer might not shut off at the end of an automatic cycle. This can result in longer drying times.

The dryer must not be installed or stored in an area where it will be exposed to water and/or weather.

Check code requirements. Some codes limit, or do not permit, installation of the dryer in garages, closets, mobile homes, or sleeping quarters. Contact your local building inspector.

NOTE: No other fuel-burning appliance can be installed in the same closet as a dryer.

Installation Clearances

- The location must be large enough to fully open the dryer door.
- Additional spacing should be considered for ease of installation and servicing.
- Additional clearances might be required for wall, door and floor moldings.
- Additional spacing of 1” (2.5 cm) on all sides of the dryer is recommended to reduce noise transfer.
- Companion appliance spacing should also be considered.

Dryer Dimensions

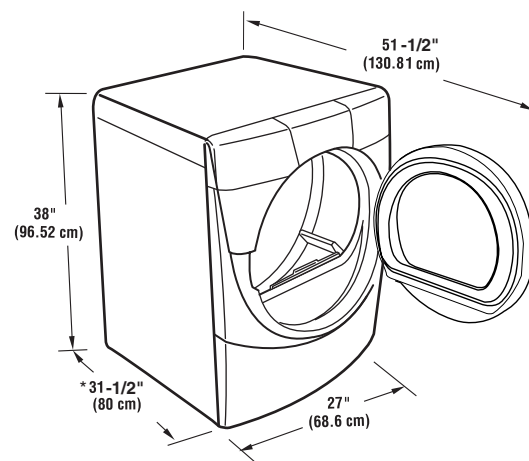

- * Most installations require a minimum 5-1/2” (14 cm) clearance behind the dryer for the exhaust vent with elbow. See “Venting Requirements.”

Custom Undercounter Installation

The dimensions shown are for the minimum spacing allowed.

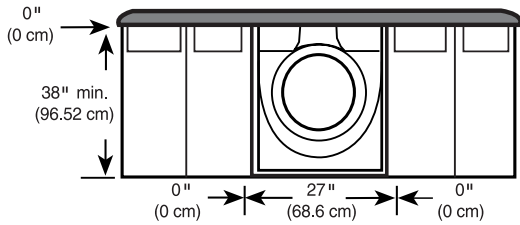

Recessed Or Closet Installation

- The dimensions shown are for the minimum spacing allowed.
- For closet installation, with a door, minimum ventilation openings in the top and bottom of the door are required. Louvered doors with equivalent ventilation openings are acceptable.

Closet Installation—Dryer Only

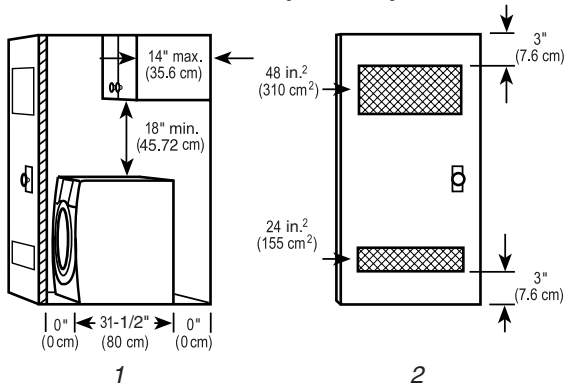

- Side view - closet or confined area
- Closet door with vents

Recessed Or Closet Installation—Dryer On Pedestal

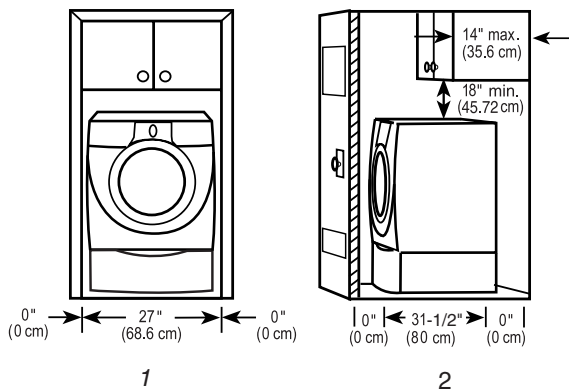

- Recessed area
- Side view - closet or confined area

Cabinet Installation

- The dimensions shown are for the minimum spacing allowed.
- For cabinet installation, with a door, minimum ventilation openings in the top of the cabinet are required.

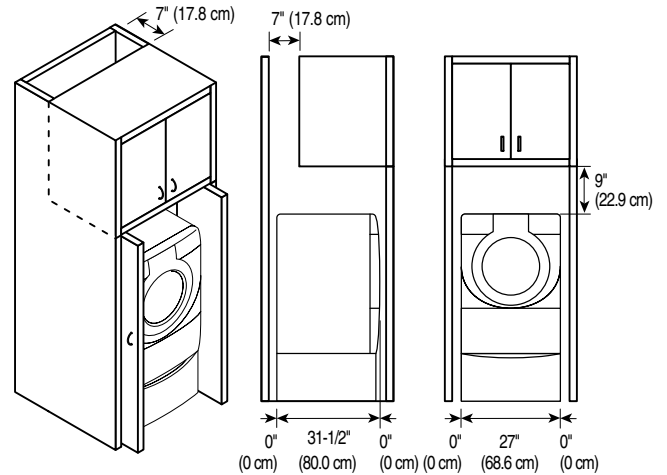

Mobile Home Installation

This dryer is suitable for mobile home installations. The installation must conform to the Manufactured Home Construction and Safety Standard, Title 24 CFR, Part 3280 (formerly the Federal Standard for Mobile Home Construction and Safety, Title 24, HUD Part 280) or Standard CAN/CSA-Z240 MH.

Mobile home installations require:

- Metal exhaust system hardware which is available for purchase from your dealer.
- Mobile Home Installation Kit, Part Number **346764**.
- Special provisions must be made in mobile homes to introduce outside air into the dryer. The opening (such as a nearby window) should be at least twice as large as the dryer exhaust opening.

ELECTRICAL REQUIREMENTS FOR ELECTRIC DRYERS—U.S.A. ONLY

It is your responsibility

- To contact a qualified electrical installer.
- To be sure that the electrical connection is adequate and in conformance with the National Electrical Code, ANSI/NFPA 70-latest edition and all local codes and ordinances.

The National Electric Code requires a 4-wire power supply connection for homes built after 1996, dryer circuits involved in remodeling after 1996, and all mobile home installations.

A copy of the above code standards can be obtained from: National Fire Protection Association, One Batterymarch Park, Quincy, MA 02269.

- To supply the required 3- or 4-wire, single phase, 120/240-volt, 60-Hz, AC-only electrical supply (or 3- or 4-wire, 120/208-volt electrical supply, if specified on the serial/rating plate) on a separate 30-amp circuit, fused on both sides of the line. A time-delay fuse or circuit breaker is recommended. Connect to an individual branch circuit. Do not have a fuse in the neutral or grounding circuit.
- Do not use an extension cord.
- If codes permit and a separate ground wire is used, it is recommended that a qualified electrician determine that the ground path is adequate.

Electrical Connection

To properly install your dryer, you must determine the type of electrical connection you will be using and follow the instructions provided for it here.

- This dryer is manufactured ready to install with a 3-wire electrical supply connection. The green cabinet-grounding conductor is permanently connected to the neutral conductor (white wire) within the dryer. If the dryer is installed with a 4-wire electrical supply connection, the green cabinet-grounding conductor must be removed from the external ground connector (green screw), and secured under the neutral terminal (center or white wire) of the terminal block. When the green cabinet-grounding conductor is secured under the neutral terminal (center or white wire) of the terminal block, the dryer cabinet is isolated from the neutral conductor.
- If local codes do not permit the connection of a cabinet ground connector to the neutral wire, see “Optional 3-wire Connection” section.
- Use a 4-wire conductor cord when the dryer is installed in a mobile home or an area where local codes do not permit grounding through the neutral.

If using a power supply cord:

Use a UL listed power supply cord kit marked for use with clothes dryers. The kit should contain:

- A UL listed 30 amp power supply cord, rated 120/240 volt minimum. The cord should be type SRD or SRDT and be at least 4 ft (1.22 m) long. The wires that connect to the dryer must end in ring terminals or spade terminals with upturned ends.
- A UL listed strain relief.

If your outlet looks like this:



4-wire receptacle (14-30R)

Then choose a 4-wire power supply cord with ring or spade terminals and UL listed strain relief. The 4-wire power supply cord, at least 4 ft (1.22 m) long, must have 4, 10-gauge solid copper wires and match a 4-wire receptacle of NEMA Type 14-30R. The ground wire (ground conductor) may be either green or bare. The neutral conductor must be identified by a white cover.

If your outlet looks like this:



3-wire receptacle (10-30R)

Then choose a 3-wire power supply cord with ring or spade terminals and UL listed strain relief. The 3-wire power supply cord, at least 4 ft (1.22 m) long, must have 3, 10-gauge solid copper wires and match a 3-wire receptacle of NEMA Type 10-30R.

If connecting by direct wire:

Power supply cable must match power supply (4-wire or 3-wire) and be:

- Flexible armored cable or nonmetallic sheathed copper cable (with ground wire), protected with flexible metallic conduit. All current-carrying wires must be insulated.
- 10-gauge solid copper wire (do not use aluminum).
- At least 5 ft (1.52 m) long.

GROUNDING INSTRUCTIONS

- For a grounded, cord-connected dryer:
This dryer must be grounded. In the event of malfunction or breakdown, grounding will reduce the risk of electric shock by providing a path of least resistance for electric current. This dryer uses a cord having an equipment-grounding conductor and a grounding plug. The plug must be plugged into an appropriate outlet that is properly installed and grounded in accordance with all local codes and ordinances.
- For a permanently connected dryer:
This dryer must be connected to a grounded metal, permanent wiring system, or an equipment-grounding conductor must be run with the circuit conductors and connected to the equipment-grounding terminal or lead on the dryer.

WARNING: Improper connection of the equipment-grounding conductor can result in a risk of electric shock. Check with a qualified electrician or service representative or personnel if you are in doubt as to whether the dryer is properly grounded. Do not modify the plug on the power supply cord: if it will not fit the outlet, have a proper outlet installed by a qualified electrician.

ELECTRICAL REQUIREMENTS FOR ELECTRIC DRYERS—CANADA ONLY

⚠ WARNING



Electrical Shock Hazard

Plug into a grounded 4 prong outlet.

Failure to do so can result in death, or electrical shock.

It is your responsibility

- To contact a qualified electrical installer.
- To be sure that the electrical connection is adequate and in conformance with the Canadian Electrical Code, C22.1-latest edition and all local codes.

A copy of the above code standards may be obtained from: Canadian Standards Association, 178 Rexdale Blvd., Toronto, ON M9W 1R3 CANADA.

- To supply the required 4-wire, single phase, 115/230-volt, 60-Hz., AC-only electrical supply on a separate 30-amp circuit, fused on both sides of the line. A time-delay fuse or circuit breaker is recommended. Connect to an individual branch circuit.

- This dryer is equipped with a CSA International Certified Power Cord intended to be plugged into a standard 14-30R wall receptacle. The cord is 5 ft. (1.52 M) in length. Be sure wall receptacle is within reach of dryer's final location.

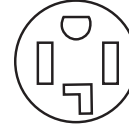

4-wire receptacle (14-30R)

- Do not use an extension cord.

If using a replacement power supply cord, it is recommended that you use Power Supply Cord Replacement Part Number **9831317**.

GROUNDING INSTRUCTIONS

- For a grounded, cord-connected dryer:

This dryer must be grounded. In the event of malfunction or breakdown, grounding will reduce the risk of electric shock by providing a path of least resistance for electric current. This dryer uses a cord having an equipment-grounding conductor and a grounding plug. The plug must be plugged into an appropriate outlet that is properly installed and grounded in accordance with all local codes and ordinances.

WARNING: Improper connection of the equipment-grounding conductor can result in a risk of electric shock. Check with a qualified electrician or service representative or personnel if you are in doubt as to whether the dryer is properly grounded. Do not modify the plug on the power supply cord: if it will not fit the outlet, have a proper outlet installed by a qualified electrician.

ELECTRICAL CONNECTION FOR ELECTRIC DRYERS—U.S.A. ONLY

Power Supply Cord

⚠️ WARNING



Fire Hazard

Use a new UL listed 30 amp power supply cord.

Use a UL listed strain relief.

Disconnect power before making electrical connections.

Connect neutral wire (white or center wire) to center terminal (silver).

Ground wire (green or bare wire) must be connected to green ground connector.

Connect remaining 2 supply wires to remaining 2 terminals (gold).

Securely tighten all electrical connections.

Failure to do so can result in death, fire, or electrical shock.

1. Unplug dryer or disconnect power.
2. Remove the hold-down screw and terminal block cover.

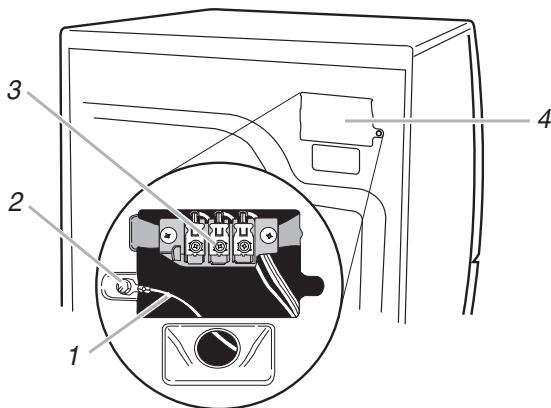

1. Neutral grounding wire (green/yellow)
2. External ground conductor screw
3. Center, silver-colored terminal block screw
4. Terminal block cover and hold-down screw

Direct Wire

⚠️ WARNING



Fire Hazard

Use 10 gauge solid copper wire.

Use a UL listed strain relief.

Disconnect power before making electrical connections.

Connect neutral wire (white or center wire) to center terminal (silver).

Ground wire (green or bare wire) must be connected to green ground connector.

Connect remaining 2 supply wires to remaining 2 terminals (gold).

Securely tighten all electrical connections.

Failure to do so can result in death, fire, or electrical shock.

3. Assemble a 3/4" (1.9 cm) UL listed strain relief (UL marking on strain relief) into the hole below the terminal block opening. Tighten strain relief screws just enough to hold the two clamp sections together. Put power supply cord through the strain relief. The strain relief should have a tight fit with the dryer cabinet and be in a horizontal position.





4. Now complete installation following instructions for your type of electrical connection:

4-wire (recommended)

3-wire (if 4-wire is not available)

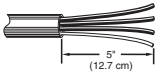
Electrical Connection Options

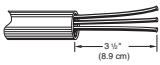
If your home has:	And you will be connecting to:	Go to Section
4-wire receptacle (NEMA Type 14-30R) 	A UL listed, 120/240 volt minimum, 30 amp, dryer power supply cord*	4-wire connection: Power supply cord
4-wire direct 	A fused disconnect or circuit breaker box*	4-wire connection: Direct Wire
3-wire receptacle (NEMA type 10-30R) 	A UL listed, 120/240 volt minimum, 30 amp., dryer power supply cord*	3-wire connection: Power supply cord
3-wire direct 	A fused disconnect or circuit breaker box*	3-wire connection: Direct Wire

* If local codes do not permit the connection of a frame-grounding conductor to the neutral wire, go to "Optional 3-Wire Connection" section.

4-Wire Connection: Power Supply Cord

IMPORTANT: A 4-wire connection is required for mobile homes and where local codes do not permit the use of 3-wire connections.

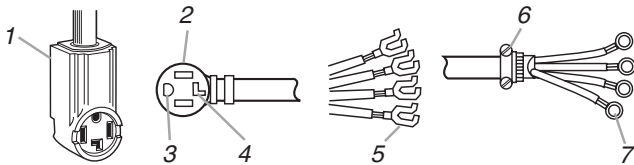

1. 4-wire receptacle (NEMA type 14-30R)
2. 4-prong plug
3. Ground prong
4. Neutral prong
5. Spade terminals with upturned ends
6. 3/4" (1.9 cm) UL listed strain relief
7. Ring terminals

1. Remove center terminal block screw.
2. Remove appliance ground wire (green with yellow stripes) from external ground conductor screw. Fasten it under center, silver-colored terminal block screw.

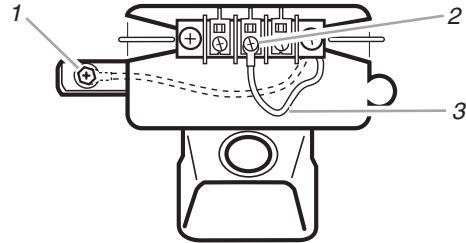

1. External ground conductor screw- Dotted line shows position of NEUTRAL ground wire before being moved to center terminal block screw
2. Center silver-colored terminal block screw
3. Green/yellow wire of harness

3. Connect ground wire (green or bare) of power supply cord to external ground conductor screw. Tighten screw.
4. Connect neutral wire (white or center wire) of power supply cord under center screw of the terminal block.

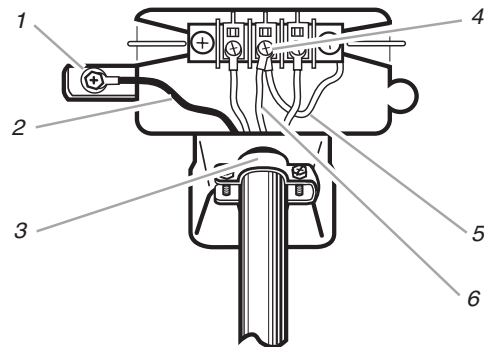

1. External ground conductor screw
2. Green or bare copper wire of power supply cord
3. 3/4" (1.9 cm) UL listed strain relief
4. Center silver-colored terminal block screw
5. Neutral grounding wire (green/yellow)
6. Neutral wire (white or center wire)

5. Connect the other wires to outer terminal block screws. Tighten screws.
6. Tighten strain relief screws.
7. Insert tab of terminal block cover into slot of dryer rear panel. Secure cover with hold-down screw.

4-Wire Connection: Direct Wire

IMPORTANT: A 4-wire connection is required for mobile homes and where local codes do not permit the use of 3-wire connections.

Direct wire cable must have 5 ft (1.52 m) of extra length so dryer can be moved if needed.

Strip 5" (12.7 cm) of outer covering from end of cable, leaving bare ground wire at 5" (12.7 cm). Cut 1-1/2" (3.8 cm) from 3 remaining wires. Strip insulation back 1" (2.5 cm). Shape ends of wires into a hook shape.

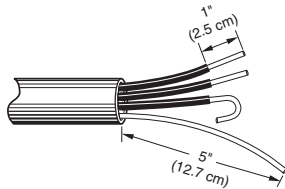

When connecting to the terminal block, place the hooked end of the wire under the screw of the terminal block (hook facing right), squeeze hooked end together and tighten screw. See example below.

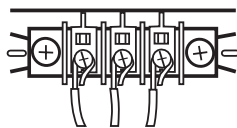

1. Remove center terminal block screw.
2. Remove appliance ground wire (green with yellow stripes) from external ground conductor screw. Fasten it under center, silver-colored terminal block screw.

3. Connect ground wire (green or bare) of power supply cable to external ground conductor screw. Tighten screw.

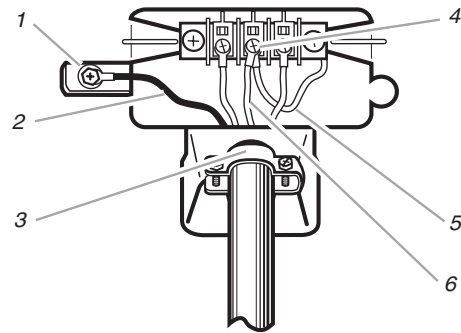

1. External ground conductor screw
2. Green or bare copper wire of power supply cord
3. 3/4" (1.9 cm) UL listed strain relief
4. Center silver-colored terminal block screw
5. Neutral grounding wire (green/yellow)
6. Neutral wire (white or center wire)

4. Place the hooked end of the neutral wire (white wire) of power supply cable under the center screw of terminal block (hook facing right). Squeeze hooked end together. Tighten screw.
5. Place hooked ends of the other power supply cable wires under the outer terminal block screws (hooks facing right). Squeeze hooked ends together. Tighten screws.

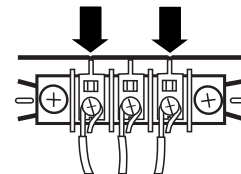

6. Tighten strain relief screws.
7. Insert tab of terminal block cover into slot of dryer rear panel. Secure cover with hold-down screw.

3-Wire Connection: Power Supply Cord

Use where local codes permit connecting cabinet-ground conductor to neutral wire.

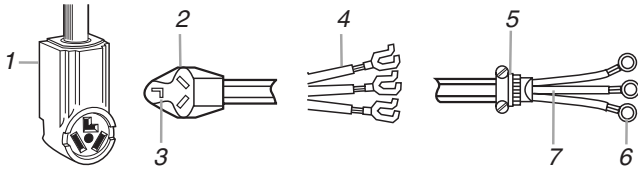

1. 3-wire receptacle (NEMA type 10-30R)
2. 3-wire plug
3. Neutral prong
4. Spade terminals with up turned ends
5. 3/4" (1.9 cm) UL listed strain relief
6. Ring terminals
7. Neutral (white or center wire)

1. Loosen or remove center terminal block screw.
2. Connect neutral wire (white or center wire) of power supply cord to the center, silver-colored terminal screw of the terminal block. Tighten screw.

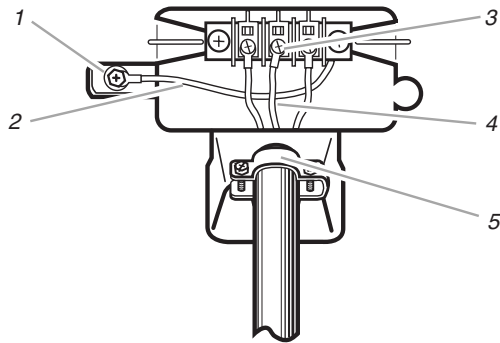

1. External ground conductor screw
2. Neutral grounding wire (green/yellow)
3. Center silver-colored terminal block screw
4. Neutral wire (white or center wire)
5. 3/4" (1.9 cm) UL listed strain relief

3. Connect the other wires to outer terminal block screws. Tighten screws.
4. Tighten strain relief screws.
5. Insert tab of terminal block cover into slot of dryer rear panel. Secure cover with hold-down screw.

3-Wire Connection: Direct Wire

Use where local codes permit connecting cabinet-ground conductor to neutral wire.

Direct wire cable must have 5 ft (1.52 m) of extra length so dryer can be moved if needed.

Strip 3-1/2" (8.9 cm) of outer covering from end of cable. Strip insulation back 1" (2.5 cm). If using 3-wire cable with ground wire, cut bare wire even with outer covering. Shape ends of wires into a hook shape.

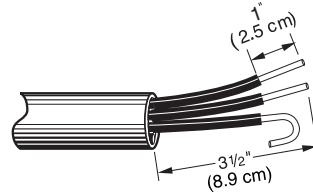

When connecting to the terminal block, place the hooked end of the wire under the screw of the terminal block (hook facing right), squeeze hooked end together and tighten screw. See example below.

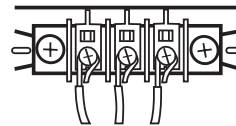

1. Loosen or remove center terminal block screw.
2. Place the hooked end of the neutral wire (white or center wire) of power supply cable under the center screw of terminal block (hook facing right). Squeeze hooked end together. Tighten screw.

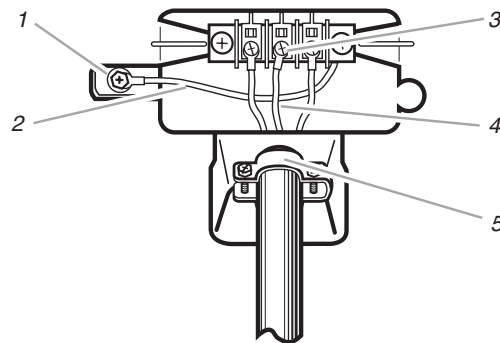

1. External ground conductor screw
2. Neutral grounding wire (green/yellow)
3. Center silver-colored terminal block screw
4. Neutral wire (white or center wire)
5. 3/4" (1.9 cm) UL listed strain relief

- Place the hooked ends of the other power supply cable wires under the outer terminal block screws (hook facing right). Squeeze hooked ends together. Tighten screws.

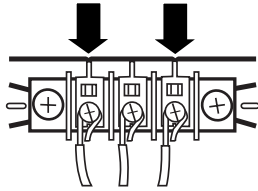

- Tighten strain relief screws.
- Insert tab of terminal block cover into slot of dryer rear panel. Secure cover with hold-down screw.

Optional 3-Wire Connection

Use for direct wire or power supply cord where local codes do not permit connecting cabinet-ground conductor to neutral wire.

- Remove center terminal block screw.
- Remove appliance ground wire (green with yellow stripes) from external ground conductor screw. Connect appliance ground wire and the neutral wire (white or center wire) of power supply cord/cable under center, silver-colored terminal block screw. Tighten screw.
- Connect the other wires to outer terminal block screws. Tighten screws.

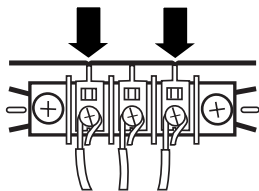

- Tighten strain relief screws.
- Insert tab of terminal block cover into slot of dryer rear panel. Secure cover with hold-down screw.
- Connect a separate copper ground wire from the external ground conductor screw to an adequate ground.

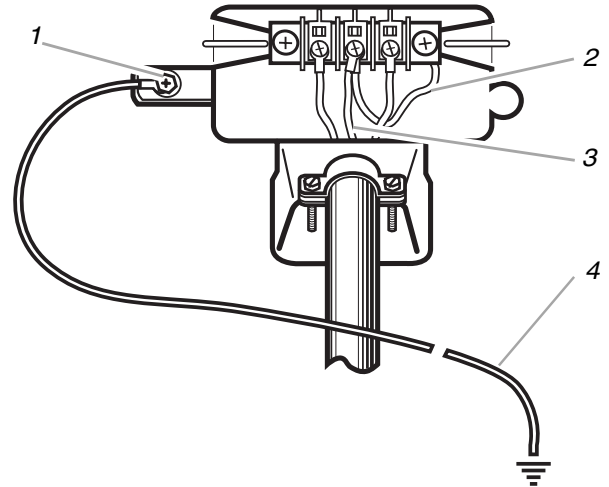

- External ground conductor screw
- Neutral grounding wire (green/yellow)
- Neutral wire (white or center wire)
- Grounding path determined by a qualified electrician

ELECTRICAL REQUIREMENTS FOR GAS DRYERS

⚠ WARNING



Electrical Shock Hazard

Plug into a grounded 3 prong outlet.

Do not remove ground prong.

Do not use an adapter.

Do not use an extension cord.

Failure to follow these instructions can result in death, fire, or electrical shock.

120-Volt, 60-Hz., AC-only, 15- or 20-amp fused electrical supply is required. (Time-delay fuse or circuit breaker is recommended.) It is recommended that a separate circuit serving only this dryer be provided.

GROUNDING INSTRUCTIONS

- For a grounded, cord-connected dryer:
This dryer must be grounded. In the event of malfunction or breakdown, grounding will reduce the risk of electric shock by providing a path of least resistance for electric current. This dryer uses a cord having an equipment-grounding conductor and a grounding plug. The plug must be plugged into an appropriate outlet that is properly installed and grounded in accordance with all local codes and ordinances.

WARNING: Improper connection of the equipment-grounding conductor can result in a risk of electric shock. Check with a qualified electrician or service representative or personnel if you are in doubt as to whether the dryer is properly grounded. Do not modify the plug on the power supply cord: if it will not fit the outlet, have a proper outlet installed by a qualified electrician.

GAS SUPPLY REQUIREMENTS

⚠ WARNING



Explosion Hazard

Use a new AGA or CSA approved gas supply line.

Install a shut-off valve.

Securely tighten all gas connections.

If connected to LP, have a qualified person make sure gas pressure does not exceed 13" (33 cm) water column.

Examples of a qualified person include: licensed heating personnel, authorized gas company personnel, and authorized service personnel.

Failure to do so can result in death, explosion, or fire.

In the State of Massachusetts, the following installation instructions apply:

- Installations and repairs must be performed by a qualified or licensed contractor, plumber, or gasfitter qualified or licensed by the State of Massachusetts.
- If using a ball valve, it shall be a T-handle type.
- A flexible gas connector, when used, must not exceed 3 feet.

Gas Type

Natural Gas:

This dryer is equipped for use with NATURAL GAS. It is design-certified by CSA International for L.P. (propane or butane) gases with appropriate conversion.

- Your dryer must have the correct burner for the type of gas in your home. Burner information is located on the rating plate in the door well of your dryer. If this information does not agree with the type of gas available, contact your dealer or call the phone numbers referenced in the “Assistance or Service” section of the Owner’s Manual.

L.P. Gas Conversion:

Conversion must be made by a qualified technician.

No attempt shall be made to convert the appliance from the gas specified on the model/serial rating plate for use with a different gas without consulting the serving gas supplier.

Gas Supply Line

- 1/2” IPS pipe is recommended.
- 3/8” approved tubing is acceptable for lengths under 20 ft (6.1 m) if local codes and gas supplier permit.
- Must include 1/8” NPT plugged tapping accessible for test gauge connection, immediately upstream of the gas connection to the dryer (see illustration in the right column).
- Must include a shutoff valve:

In the U.S.A.:

An individual manual shutoff valve must be installed within six (6) feet (1.8 m) of the dryer in accordance with the National Fuel Gas Code, ANSI Z223.1.

In Canada:

An individual manual shutoff valve must be installed in accordance with the B149.1, Natural Gas and Propane Installation Code. It is recommended that an individual manual shutoff valve be installed within six (6) feet (1.8 m) of the dryer.

The location should be easy to reach for opening and closing.

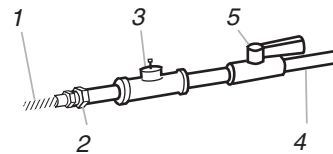

1. 3/8” flexible gas connector
 2. 3/8” pipe to flare adapter fitting
 3. 1/8” NPT plugged tapping
 4. 1/2” NPT gas supply line
 5. Gas shutoff valve

Gas Supply Connection Requirements

There are many methods by which your gas dryer can be connected to the gas supply. Listed here are some guidelines for two different methods of connection.

Option 1 (Recommended Method)

Flexible stainless steel gas connector:

- If local codes permit, use a new flexible stainless steel gas connector (Design Certified by the American Gas Association or CSA International) to connect your dryer to the rigid gas supply line. Use an elbow and a 3/8” flare x 3/8” NPT adapter fitting between the stainless steel gas connector and the dryer gas pipe, as needed to prevent kinking.

Option 2 (Alternate Method)

Approved aluminum or copper tubing:

- Lengths under 20 ft (6.1 m) can use 3/8” approved tubing (if codes and gas supplier permit).
 - If you are using natural gas, do not use copper tubing.
 - 3/8” flare x 3/8” NPT adapter fitting between dryer pipe and 3/8” approved tubing.
 - Lengths over 20 ft (6.1 m) should use larger tubing and a different size adapter fitting.
 - If your dryer has been converted to use L.P. gas, 3/8” L.P. compatible copper tubing can be used. If the total length of the supply line is more than 20 ft (6.1 m), use larger tubing.
- NOTE:** Pipe joint compounds that resist the action of L.P. gas must be used. Do not use TEFLON®* tape.

* TEFLON is a registered trademark of E.I. DuPont De Nemours and Company.

Dryer Gas Pipe

The gas pipe that comes out through the rear of your dryer has a 3/8" male pipe thread.

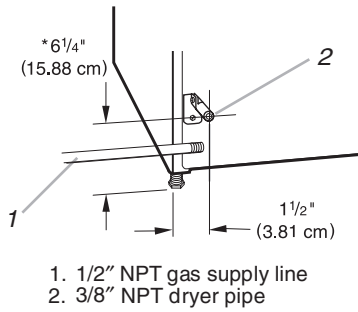

* **NOTE:** If the dryer is mounted on a pedestal, the gas pipe height must be an additional 13" (33 cm) from the floor.

Burner Input Requirements

Elevations up to 10,000 feet (3,048 meters):

- The design of this dryer is certified by CSA International for use at altitudes up to 10,000 ft (3,048 m) above sea level at the B.T.U. rating indicated on the model/serial number plate. Burner input adjustments are not required when the dryer is operated up to this elevation.

Elevations above 10,000 feet (3,048 meters):

- When installed above 10,000 ft (3,048 m) a 4% reduction of the burner B.T.U. rating shown on the model/serial number plate is required for each 1,000 ft (305 m) increase in elevation.

Gas supply Pressure Testing

- The dryer must be disconnected from the gas supply piping system during pressure testing at pressures greater than 1/2 psi.

VENTING REQUIREMENTS

⚠ WARNING

Fire Hazard Use a heavy metal vent. Do not use a plastic vent. Do not use a metal foil vent. Failure to follow these instructions can result in death or fire.

WARNING: To reduce the risk of fire, this dryer **MUST BE EXHAUSTED OUTDOORS.**

4" (10.2 cm) heavy metal exhaust vent and clamps must be used. DURASAFE™ vent products are recommended.

DURASAFE™ vent products can be purchased from your dealer or by calling Whirlpool Parts and Accessories.

- The dryer exhaust must not be connected into any gas vent, chimney, wall, ceiling, or a concealed space of a building.
- Do not use an exhaust hood with a magnetic latch.
- Do not install flexible metal vent in enclosed walls, ceilings or floors.
- Use clamps to seal all joints. Exhaust vent must not be connected or secured with screws or other fastening devices which extend into the interior of the duct. Do not use duct tape.

IMPORTANT: Observe all governing codes and ordinances.

Improper venting can cause moisture and lint to collect indoors, which may result in:

- Moisture damage to woodwork, furniture, paint, wallpaper, carpets, etc.
- Housecleaning problems and health problems.

Use a heavy metal vent. Do not use plastic or metal foil vent.

Rigid metal vent is recommended to prevent crushing and kinking.

Flexible metal vent must be fully extended and supported when the dryer is in its final position. Remove excess flexible metal vent to avoid sagging and kinking that can result in reduced airflow and poor performance.

An exhaust hood should cap the vent to prevent rodents and insects from entering the home.

Exhaust hood must be at least 12" (30.5 cm) from the ground or any object that is in the path of the exhaust (such as flowers, rocks or bushes, etc.).

If using an existing vent system, clean lint from the entire length of the system and make sure exhaust hood is not plugged with lint. Replace any plastic or metal foil vent with rigid metal or flexible metal vent.

PLAN VENT SYSTEM

Typical Exhaust Installations

Typical installations vent the dryer from the rear of the dryer. Other installations are possible.

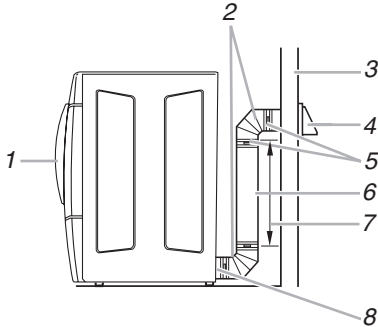

- | | |
|-----------------|--|
| 1. Dryer | 6. Rigid metal or flexible metal vent |
| 2. Elbow | 7. Vent length necessary to connect elbows |
| 3. Wall | 8. Exhaust outlet |
| 4. Exhaust hood | |
| 5. Clamps | |

Optional Exhaust Installations

This dryer can be converted to exhaust out the right side, left side, or through the bottom. Contact your local dealer to have the dryer converted.

⚠ WARNING

Fire Hazard

Cover unused exhaust holes with the following kit:

280028 (meteorite)
279818 (white)

Contact your local dealer.

Failure to follow these instructions can result in death, fire, electrical shock, or serious injury.

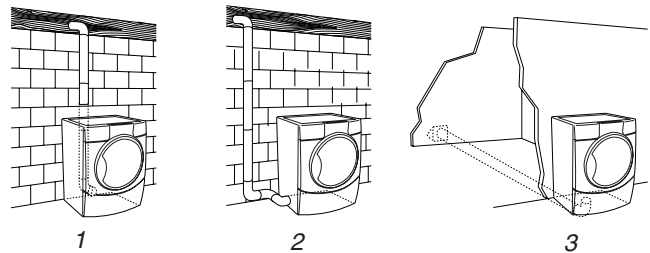

1. Standard rear offset exhaust installation
2. Left or right side exhaust installation
3. Bottom exhaust installation (Not an option with pedestal installations.)

Alternate Installations For Close Clearances

Venting systems come in many varieties. Select the type best for your installation. Two close-clearance installations are shown. Refer to the manufacturer's instructions.

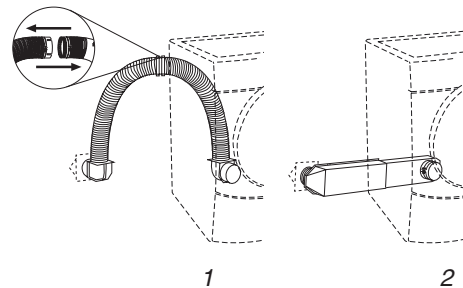

1. Over the top installation (also available with one offset elbow)
2. Periscope installation

NOTE: The following kits for close clearance alternate installations are available for purchase.

- Over the top Installation:
Part Number **4396028**
- Periscope Installation (For use with dryer vent to wall vent mismatch):
Part Number **4396037** - 0" (0 cm) to 18" (45.72 cm) mismatch
Part Number **4396011** - 18" (45.72 cm) to 29" (73.66 cm) mismatch
Part Number **4396014** - 29" (73.66 cm) to 50" (127 cm) mismatch

Special Provisions For Mobile Home Installations

The exhaust vent must be securely fastened to a noncombustible portion of the mobile home structure and must not terminate beneath the mobile home. Terminate the exhaust vent outside.

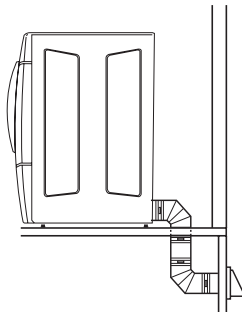

Determine Vent Length

1. Select the route that will provide the straightest and most direct path outdoors. Plan the installation to use the fewest number of elbows and turns. When using elbows or making turns, allow as much room as possible. Bend vent gradually to avoid kinking. Avoid 90° turns.
2. Determine vent length.
The maximum length of the exhaust system depends upon:
 - The type of vent (rigid metal or flexible metal).
 - The number of elbows used.
 - Type of hood.

Recommended hood styles are shown here.

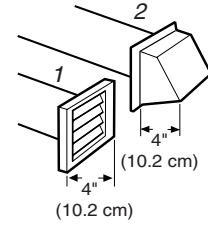

1. Louvered hood style
2. Box hood style

The angled hood style (shown following) is acceptable.

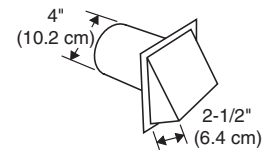

See the exhaust vent length chart that matches your hood type for the maximum vent lengths you can use.

Exhaust systems longer than specified will:

- Shorten the life of the dryer.
 - Reduce performance, resulting in longer drying times and increased energy usage.
3. Determine the number of elbows you will need.

IMPORTANT: Do not use vent runs longer than those specified in the Vent Length Chart.

The following chart helps you determine your maximum vent length based on the number of 90° turns or elbows you will need and the type of vent (rigid or flexible metal) and hood that you will use.

Vent Length Chart

Number of 90° turns or elbows	Type of vent	Box or Louvered hoods	Angled hoods
0	Rigid Metal	64 ft (20 m)	58 ft (17.7 m)
	Flexible Metal	36 ft (11 m)	28 ft (8.5 m)
1	Rigid Metal	54 ft (16.5 m)	48 ft (14.6 m)
	Flexible Metal	31 ft (9.4 m)	23 ft (7 m)
2	Rigid Metal	44 ft (13.4 m)	38 ft (11.6 m)
	Flexible Metal	27 ft (8.2 m)	19 ft (5.8 m)
3	Rigid Metal	35 ft (10.7 m)	29 ft (8.8 m)
	Flexible Metal	25 ft (7.6 m)	17 ft (5.2 m)
4	Rigid Metal	27 ft (8.2 m)	21 ft (6.4 m)
	Flexible Metal	23 ft (7 m)	15 ft (4.6 m)

INSTALL VENT SYSTEM

1. Optional: Put on safety glasses and gloves.
2. Install exhaust hood. Use caulking compound to seal exterior wall opening around exhaust hood.
3. Connect vent to exhaust hood. Vent must fit inside exhaust hood. Secure vent to exhaust hood with 4" (10.2 cm) clamp.
4. Run vent to dryer location. Use the straightest path possible (see "Determine Vent Length"). Avoid 90° turns. Use clamps to seal all joints. Do not use duct tape, screws or other fastening devices that extend into the interior of the vent to secure vent.

INSTALL LEVELING LEGS

⚠ WARNING

Excessive Weight Hazard

Use two or more people to move and install dryer.

Failure to do so can result in back or other injury.

1. To protect the floor, use a large flat piece of cardboard from the dryer carton. Place cardboard under the entire back edge of the dryer.
2. Firmly grasp the body of the dryer (not the console panel). Gently lay the dryer on the cardboard.

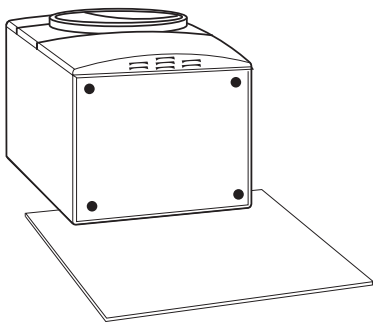

3. Examine the leveling legs. Find the diamond marking.



4. Screw the legs into the leg holes by hand. Use a wrench to finish turning the legs until the diamond marking is no longer visible.
5. Place a carton corner post under each of the 2 dryer back corners. Stand the dryer up. Slide the dryer on the corner posts until it is close to its final location. Leave enough room to connect the exhaust vent or gas line.
6. Once connection is made and dryer is in final location, remove corner posts and cardboard.

For Mobile Home Use

Gas dryers must be securely fastened to the floor at the time of installation.

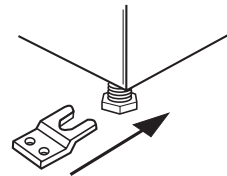

Mobile home installations require a "Mobile Home Installation Kit."

LEVEL DRYER

Check the levelness of the dryer. Check levelness first side to side, then front to back.

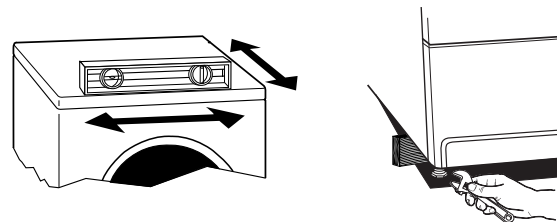

If the dryer is not level, prop up the dryer using a wood block. Use a wrench to adjust the legs up or down and check again for levelness.

NOTE: It might be necessary to level the dryer again after it has been moved into its final position.

MAKE GAS CONNECTION

1. Remove the red cap from the gas pipe. Move the dryer close to its final position.
2. Using a wrench to tighten, connect the gas supply to the dryer. Use pipe joint compound on all non-flared male threads. If flexible metal tubing is used, be sure there are no kinks.

NOTE: For L.P. gas connections, you must use pipe joint compound resistant to the action of L.P. gas. Do not use TEFLON® tape.

A combination of pipe fittings must be used to connect the dryer to the existing gas line. Shown following is a recommended connection. Your connection may be different, according to the supply line type, size, and location.

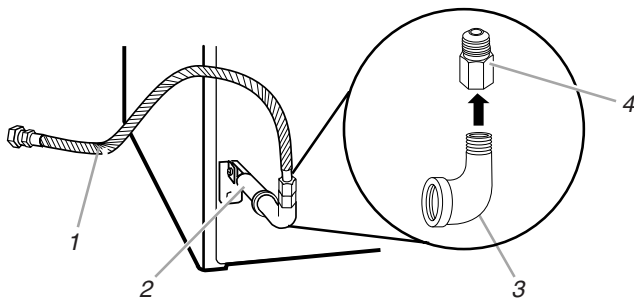

1. 3/8" flexible gas connector
2. 3/8" dryer pipe
3. 3/8" to 3/8" pipe elbow
4. 3/8" pipe-to-flare adapter fitting

3. Open the shutoff valve in the supply line. The valve is open when the handle is parallel to the gas pipe.

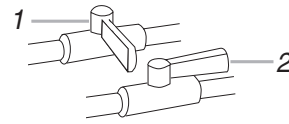

1. Closed valve
2. Open valve

4. Test all connections by brushing on an approved noncorrosive leak-detection solution. Bubbles will show a leak. Correct any leak found.

CONNECT VENT

1. Using a 4" (10.2-cm) clamp, connect vent to exhaust outlet in dryer. If connecting to existing vent, make sure the vent is clean. The dryer vent must fit over the dryer exhaust outlet and inside the exhaust hood. Make sure the vent is secured to exhaust hood with a 4" (10.2-cm) clamp.
2. Move dryer into final position. Do not crush or kink vent. Make sure dryer is level.
3. *Gas Dryers Only:* Check to be sure there are no kinks in the flexible gas line.

REVERSING DOOR SWING

You can change your door swing from a right-side opening to a left-side opening, if desired.

Remove The Door

1. Open the dryer door. Remove the 4 screws that hold the door hinge on the front panel of the dryer. Loosen, but do not remove, the screw with the top keyhole opening last (second from the top).

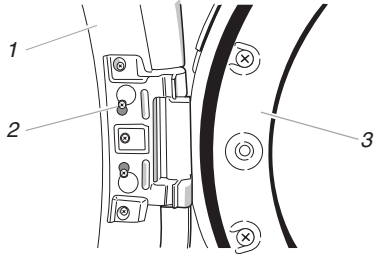

1. Dryer
2. Do not remove
3. Dryer door

2. Lift and pull forward on the door so that the keyhole clears the screwhead. Remove the door.
3. Lay the dryer door on a flat, protected surface with the inside door assembly facing up. Remove the last screw from step 1. Remove the 2 screws holding the handle to the door.

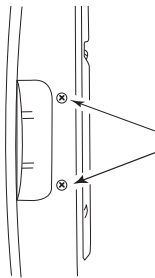

4. Remove the 6 screws to release the outer door assembly from the inner door assembly (see illustration). It is important that you remove only the 6 indicated screws.

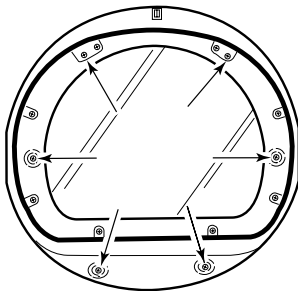

5. Lift the inner door assembly off of the outer door assembly. Unsnap the handle from the outer door assembly, move it to the other side, and snap in. Set the outer door assembly aside.

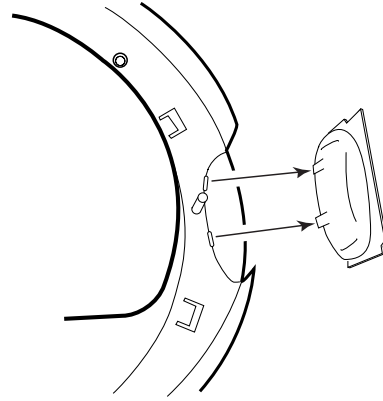

Reverse The Hinge And Hinge Bracket

1. Place the inner door, screwhead side up, on the work surface.
2. Remove the 4 screws that hold the hinge to the door.

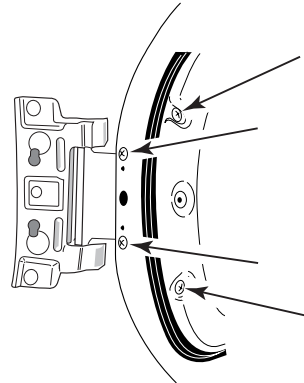

3. Remove the 2 screws that hold the handle bracket to the door.

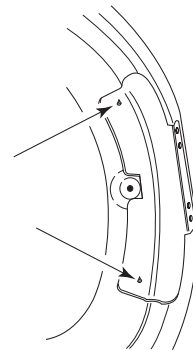

4. Move hinge to the other side and reattach with the 4 screws removed in step 2.
5. Move handle bracket to the other side and reattach with the 2 screws removed in step 3.
6. Set the inner door assembly aside.

Reinstalling The Door

1. Check for fingerprints on the glass. Clean if necessary.
2. Place the inner door assembly into the outer door assembly. Align the hinge in the opening on the side. To fit correctly, the inside door assembly edge is completely inside the outside door assembly edge.
3. Reassemble the inner and outer door assemblies with the 6 screws.

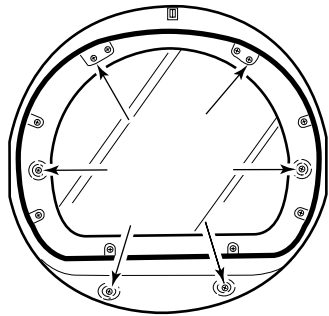

4. Replace the 2 handle screws for the door handle of the door assembly.
5. Use a small flat-blade screwdriver to remove hole plugs in the door opening. Slide the head of the screwdriver under the cap of each hole plug, being careful not to scratch the dryer surface. Lift up. Remove the hole plugs in the door opening and insert in the opposite side.

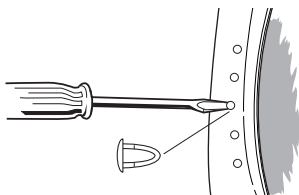

6. Insert a screw in the second opening from the top of the hinge opening and partially tighten. Hang the door by placing the top hinge keyhole over the second screwhead and tighten the screw. By putting this screw in first, the door will hang in place while you insert and tighten the remaining 4 screws.

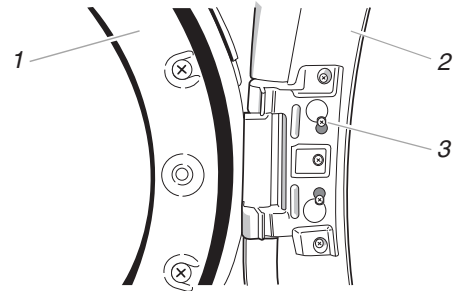

1. Dryer door
2. Dryer
3. Insert this screw first

7. Close the door and check that it latches securely.

COMPLETE THE INSTALLATION

1. Check to be sure all parts are now installed. If there is an extra part, go back through the steps to see which step was skipped.
2. Check to be sure you have all of your tools.
3. Dispose of all packaging materials.
4. Check the dryer's final location. Be sure the vent is not crushed or kinked.
5. Check to be sure the dryer is level (see "Level Dryer" on page 2-18).
6. Plug into a grounded 3-prong outlet. Turn power on.
7. Remove the blue protective film on the console and any tape remaining on the dryer.
8. Wipe the dryer drum interior thoroughly with a damp cloth to remove any dust.
9. Set the dryer on a full heat cycle (not an air cycle) for 20 minutes and start the dryer.

Continued on the next page.

If the dryer will not start, check the following:

- Controls are set in a running or “On” position.
- Start button has been pushed firmly.
- Dryer is plugged into a grounded 3-prong outlet.
- Electrical supply is connected.
- House fuse is intact and tight, or circuit breaker has not tripped.
- Dryer door is closed.

10. When the dryer has been running for 5 minutes, open the dryer door and feel for heat.

11. *Gas Dryers Only:* If you do not feel heat, turn the dryer off and check to see that the gas supply line shutoff valve is open.

If the gas supply line shutoff valve is closed, open it, then repeat the 5-minute test as previously outlined.

12. *Electric Dryers Only:* If you do not feel heat, turn the dryer off and check the following:

There may be two fuses or circuit breakers for the dryer. Check to make sure both fuses are intact and tight, or that both circuit breakers have not tripped.

INSTALLING THE DRYER ON THE PEDESTAL

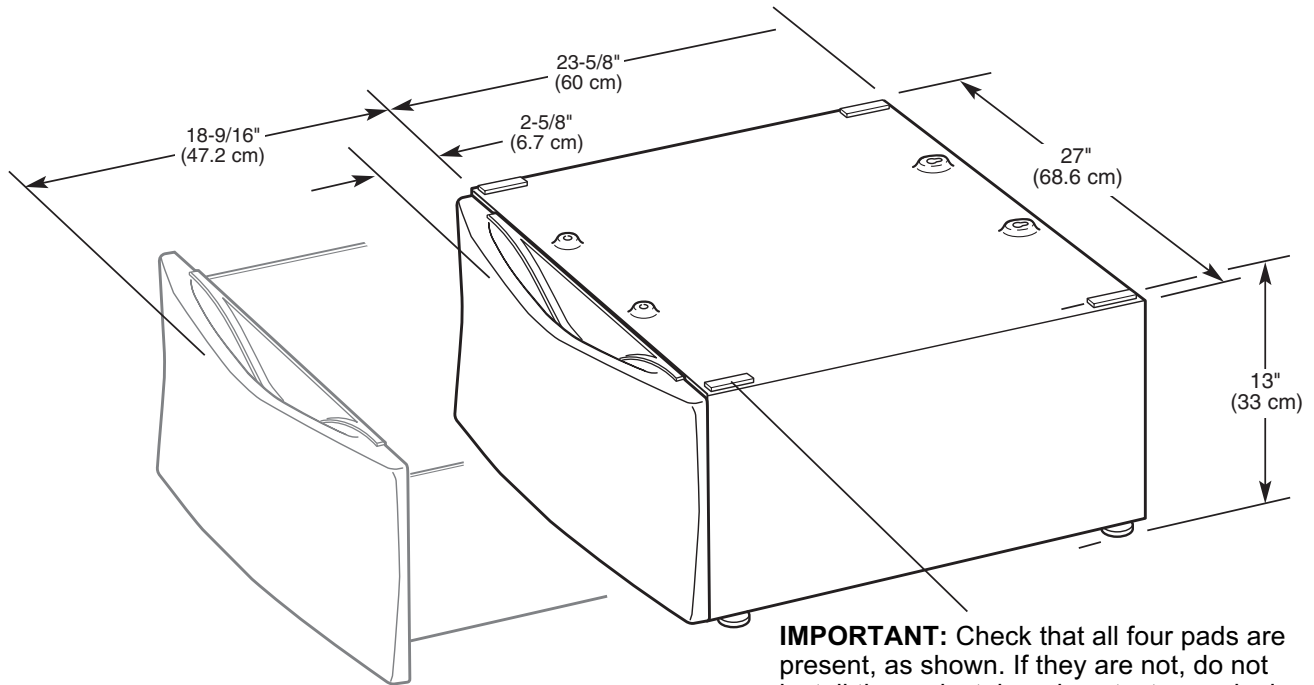

IMPORTANT: Check that all four pads are present, as shown. If they are not, do not install the pedestal, and contact your dealer.

⚠ WARNING



Explosion Hazard

Keep flammable materials and vapors, such as gasoline, away from dryer.

Place dryer at least 18 inches (45.7 cm) above the floor for a garage installation.

Failure to do so can result in death, explosion, or fire.

UNINSTALLING THE DRYER

⚠ WARNING

Excessive Weight Hazard

Use two or more people to move and uninstall dryer.

Failure to do so can result in back or other injury.

IMPORTANT: If the dryer is already installed, it must be uninstalled. See Installation Instructions that came with the dryer for tools required.

1. Unplug dryer or disconnect power.
2. *Gas Dryers Only:* Turn off the gas supply.
3. Pull the dryer away from the wall enough to loosen the vent clamp. Loosen the clamp and carefully remove the exhaust vent from the dryer exhaust outlet.
4. *Gas Dryers Only:* Disconnect the flexible gas supply line from the dryer. Put a piece of tape over the open ends of the gas line connection fittings.
5. Pull the dryer away from the wall so it can be tipped on its back.
6. Protect the floor with a large piece of cardboard cut from the pedestal carton. Lay the dryer on its back so that the cardboard is under the entire lower back edge.

INSTALLING THE PEDESTAL

⚠ WARNING

Excessive Weight Hazard

Use two or more people to move and install pedestal.

Failure to do so can result in back or other injury.

1. Open the pedestal drawer, and remove the envelope taped inside the drawer. This envelope contains four (4) #12 x 5/8" (1.6 cm) hex-head sheet metal screws that will be used in step 4.
2. Remove the phillips screw from both drawer slides and save the screws. Remove the drawer from the slides and set it aside. Push the drawer slides back into the pedestal.

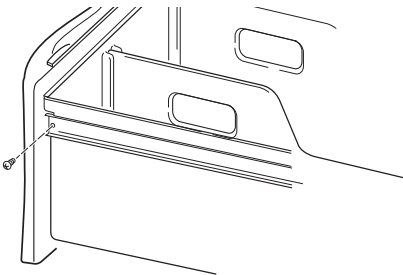

3. Remove the four feet from the dryer, but **DO NOT** install the feet that were supplied with the new dryer.
4. Partially install the two lower hex-head sheet metal screws. Leave a space of about 3/8" (1 cm) between the screw head and the bottom of the dryer.

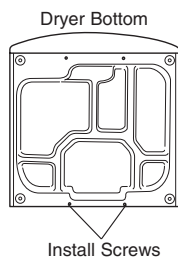

5. Move the pedestal against the dryer bottom, and slide the pedestal's keyhole slots over the lower two partially installed screws. Position the pedestal toward the front of the dryer and install the two remaining hex-head sheet metal screws. **Do not tighten completely.**
Align the sides of the pedestal so that they are even with the sides of the dryer. Reach inside the pedestal drawer opening, and securely tighten all four pedestal screws.

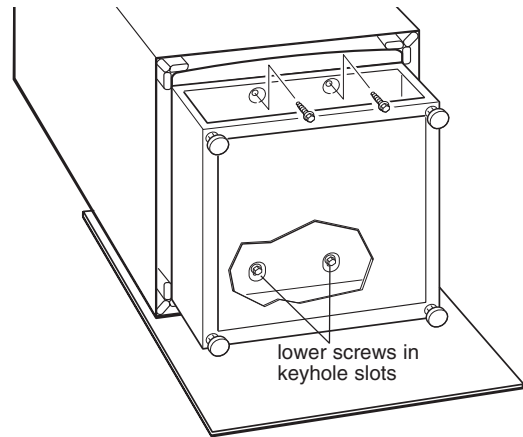

6. Tip the dryer and pedestal assembly back to an upright position and remove protective cardboard.
7. Slide the dryer close to its final location.
8. Follow the Installation Instructions that were supplied with the dryer and finish installing or reinstalling the unit.
9. Locate the 1/4" hex nut on the top of each pedestal foot. Reach inside the pedestal and use a ratchet or open-end wrench, and adjust the feet up or down, as necessary to level the dryer and pedestal.

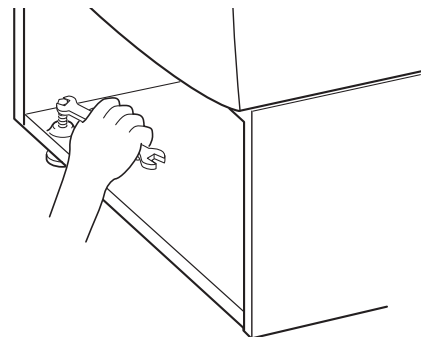

10. When the dryer is level, use a 9/16" open-end wrench to securely tighten the locknuts on all four feet against the pedestal.

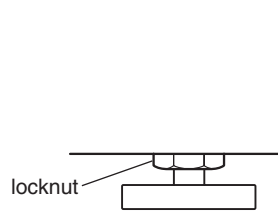

11. Pull both drawer slides out and reassemble the drawer to the drawer slides with the two (2) phillips screws you removed earlier. **NOTE:** Use of the two (2) dividers is optional.

12. Close the pedestal drawer.

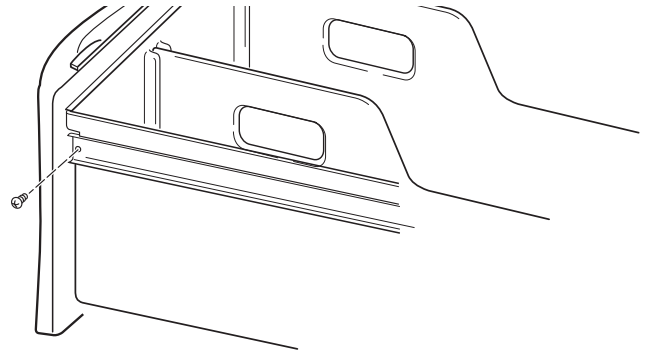

— NOTES —

PRODUCT OPERATION

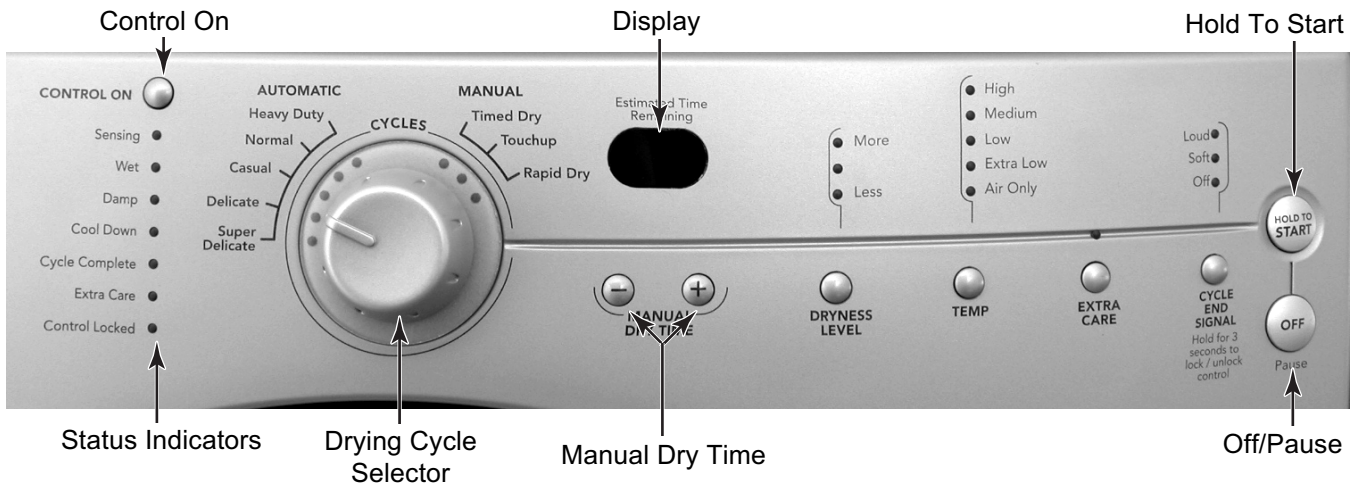

! WARNING



Explosion Hazard
 Keep flammable materials and vapors, such as gasoline, away from dryer.
 Do not dry anything that has ever had anything flammable on it (even after washing).
 Failure to follow these instructions can result in death, explosion, or fire.

! WARNING



Fire Hazard
 No washer can completely remove oil. Do not dry anything that has ever had any type of oil on it (including cooking oils).
 Items containing foam, rubber, or plastic must be dried on a clothesline or by using an Air Cycle.
 Failure to follow these instructions can result in death or fire.

STARTING THE DRYER

The following is a guide to starting the dryer. Please refer to specific sections of the Owner's Manual for more detailed information.

1. Clean the lint screen before or after each cycle.
2. Place the laundry into the dryer and close the door.
3. Rotate the dial to select either an Automatic or Manual Cycle, then press the CONTROL ON button. The preset settings and drying time for the cycle chosen will be displayed.

To use an Automatic Cycle:

- Point the dial to an Automatic Cycle.
- Select the DRYNESS LEVEL to adjust how dry you want the clothes. The time displayed is an estimated length of the cycle based on the dryness level selected. As the cycle runs, the control senses the dryness of the load and adjusts the time automatically for the selected dryness level.

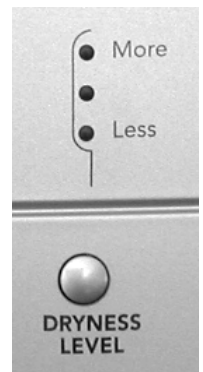

NOTE: Time is not adjustable for Automatic Cycles. Pressing the MANUAL DRY TIME (- or +) buttons will cause a triple beep, indicating that the time cannot be changed.

- Press the EXTRA CARE feature button, if this option is desired.
- Press the CYCLE END SIGNAL button to set the signal volume to the desired level.
- Press and hold the HOLD TO START button until the dryer starts (about 1 second).

Once an Automatic cycle has started, the Extra Care feature and the Cycle End Signal level can be adjusted. Press the OFF button twice to stop the dryer and clear the settings, allowing you to select another cycle and dryness level.

To use a Manual Cycle:

- Rotate the dial to select a Manual Cycle.
- Press the MANUAL DRY TIME (– or +) buttons until the desired drying time is displayed. Tap – or + and the time will change by 1-minute intervals. Press and hold – or + and the time will change by 5-minute intervals. The initial time displayed is the actual drying time.



NOTE: The Manual Dry Time feature can only be used with Manual Cycles.

- Press TEMP until the desired temperature glows.

NOTE: Pressing the DRYNESS LEVEL button will cause the triple beep, indicating that this option is not selectable. Also, a dryness level is not indicated.

- Press the EXTRA CARE feature button if this option is desired.
- Press the CYCLE END SIGNAL button to set the volume to the desired level.
- Press and hold the HOLD TO START button until the dryer starts (about 1 second).

During a Manual Cycle, you can change the settings for Time, Temperature, the Extra Care feature, and the Cycle End Signal. Press the OFF button twice to stop the dryer and clear the settings, allowing you to select another cycle.

STOPPING THE DRYER

To stop the dryer at any time:

Press OFF twice or open the door.

PAUSING OR RESTARTING

To pause the dryer at anytime:

Open the door or press OFF once.

To restart the dryer:

Close the door and press and hold the HOLD TO START button until the dryer starts.

NOTE: Drying will continue from where the cycle was interrupted if you close the door and press START within 5 minutes. If the cycle is interrupted for more than 5 minutes, the dryer will shut off. Select the new cycle settings before restarting the dryer.

CONTROL LOCKED

This feature allows you to lock your settings to prevent unintended use of the dryer. You can also use this feature to prevent unintended cycle or option changes during dryer operation.

To enable the Control Locked feature when the dryer is running:

Press and hold the CYCLE END SIGNAL button for 3 seconds. The control is locked when a single beep is heard and the Control Locked status light is on.

- When the dryer is off, it is not necessary to press the CONTROL ON button before activating the Control Locked feature.

To unlock the Control Locked feature:

Press and hold the CYCLE END SIGNAL button for 3 seconds to turn this feature off.

NOTE: When the dryer is running and Control Locked is on, the dryer can be stopped by pressing the OFF button, but cannot be restarted until the control is unlocked.

STATUS LIGHTS

The Status indicator lights show the progress of the dryer. Each of the lights indicate as follows:

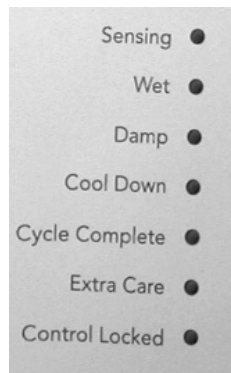

Sensing

When the dryer is first turned on, the Sensing light glows until a wet item is detected.

- In an Automatic cycle, if a wet item has not been detected within 10 minutes, the Sensing light will turn off, and the dryer will shut down.
- In a Manual cycle, if a wet item is not detected after 10 minutes, the Wet light turns on, and the selected cycle continues.

Wet

The Wet light will turn on when a wet item has been detected in the dryer. The Wet light will remain on until:

- The damp dry point is reached in an Automatic cycle.
- The dryer enters the cool down period in a Manual cycle.

Damp

The Damp light indicates that the load has reached a damp dry level.

NOTE: The Damp light is not used with Manual cycles.

Cool Down

The Cool Down light glows during the cool down part of the cycle. Laundry is cooling down for ease in handling.

Cycle Complete

The Cycle Complete light glows when a drying cycle is finished. If the Extra Care feature has been selected, the Extra Care feature indicator light will also be on.

The Cycle Complete light turns off 1 hour after the end of a drying cycle (including the Extra Care cycle of 2 hours), when OFF is pressed, or when the door is opened.

Extra Care Feature

The Extra Care feature light glows when this option is selected. This indicator stays on with the Cycle Complete light.

Control Locked

The Control Locked light glows when this option is enabled.

Indicator Lights

Other indicator lights on the control panel show Cycle, Temperature, and Cycle End Signal settings that are selected.

The time display will indicate the estimated or actual time remaining in a cycle.

CYCLE DESCRIPTIONS



Automatic Cycles

The Automatic Cycles allow the user to match a cycle to the type of load to be dried. A sensor detects the moisture in the clothes, and automatically adjusts the drying time for optimal drying.

Heavy Duty

Use this cycle to get High heat for heavy fabrics, such as cotton towels or bedspreads.

Normal

Use this cycle to get Medium heat for drying sturdy fabrics, such as work clothes.

Casual

Use this cycle to get Medium heat for no-iron fabrics, such as sport shirts, casual business clothes, and permanent press.

Delicate

Use this cycle to get Low heat for drying synthetic fabrics, washable knit fabrics, and no-iron finishes.

Super Delicate

Use this cycle to get Extra Low heat for drying items such as lingerie, exercise wear, or sheer curtains.

Automatic Preset Cycle Settings

Automatic Cycles Load Type	Temp.	Time* (Minutes)
HEAVY DUTY Heavyweight, towels	High	40
NORMAL Corduroys, work clothes	Medium	34
CASUAL Permanent press, synthetics	Medium	36
DELICATE Lingerie, blouses, washable woolens	Low	28
SUPER DELICATE Exercise wear, sheer curtains, lace	Extra Low	22

*Estimated Time with Dryness Level (medium) setting.

Manual Cycles

The Manual Cycles allow the user to select a specific amount of drying time and a drying temperature. When a Manual Cycle is selected, the Estimated Time Remaining display shows the actual time remaining in the cycle. The actual time in the cycle can be changed by pressing the MANUAL DRY TIME (- or +) buttons.

Timed Dry

Use this cycle to complete drying time when items are still damp after an Automatic Cycle.

Touchup

Use this setting to remove wrinkles from items, such as clothes packed in a suitcase, or items wrinkled from being left in the dryer too long.

Rapid Dry

Use this cycle for drying small loads or loads that need a short drying time.

Manual Preset Cycle Settings

Manual Cycles Load Type	Temp.	Default Time (Minutes)
TIMED DRY Heavyweight, bulk, bedspreads, work clothes	High	40
TOUCHUP Remove wrinkles	Medium	20
RAPID DRY Small loads	High	27

ADDITIONAL FEATURES

Extra Care Feature

When you are unable to remove a load of clothes from the dryer as soon as it stops, wrinkles can form. The Extra Care feature periodically tumbles, rearranges and fluffs the load to avoid wrinkles.

- Press the EXTRA CARE feature button to get up to 120 minutes of heat-free, periodic tumbling at the end of a cycle.
- Stop at any time by pressing the EXTRA CARE feature button, or opening the dryer door.
- For the Casual Cycle, the Extra Care feature is preset to "On." The other Automatic Cycles will retain the Extra Care feature setting. (For example, if you select the Extra Care feature in the Normal cycle, the Extra Care feature will be on the next time you select the Normal cycle.)

NOTE: If you do not select the Extra Care feature, the dryer stops after the cool down period.

Temperature

Use the Temperature settings to select temperatures for the Manual Cycles. Press TEMP until the desired temperature setting glows. Temperature settings cannot be used with the Automatic Cycles.

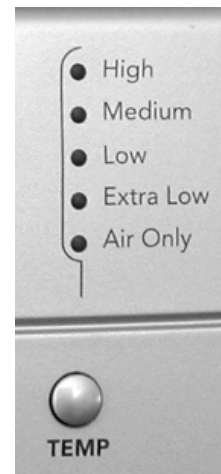

Air Only

Use the Air Only setting for items that require drying without heat, such as rubber, plastic, and heat-sensitive fabrics.

Type of Load	Time* (Minutes)
Foam rubber - pillows, padded bras, stuffed toys	20 - 30
Plastic - Shower curtains, tablecloths	20 - 30
Rubber-backed rugs	40 - 50
Olefin, polypropylene, sheer nylon	10 - 20

*Reset time to complete drying, if needed.

When using Air Only

- Check to see that coverings are securely stitched.
- Shake and fluff pillows by hand periodically during the cycle.
- Dry item completely. Foam rubber pillows are slow to dry.

NOTE: Automatic Cycles are not available when using the Air Only setting.

Cycle End Signal

The Cycle End Signal produces an audible sound when the drying cycle is finished. Promptly removing clothes at the end of the cycle reduces wrinkling.



Press the CYCLE END SIGNAL to adjust the sound level or turn off the signal.

NOTE: When the Extra Care feature is selected and the Cycle End Signal is on, an audible sound will emit every 5 minutes until the clothes are removed, or the Extra Care feature is finished.

COMPONENT ACCESS

This section instructs you on how to service each component inside the Ensemble™ Front-Loading Gas and Electric Dryers. The components and their locations are shown below.

COMPONENT LOCATIONS

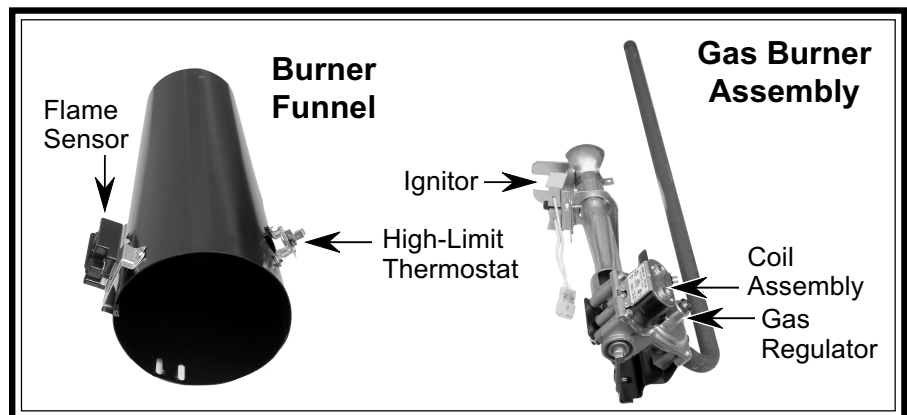
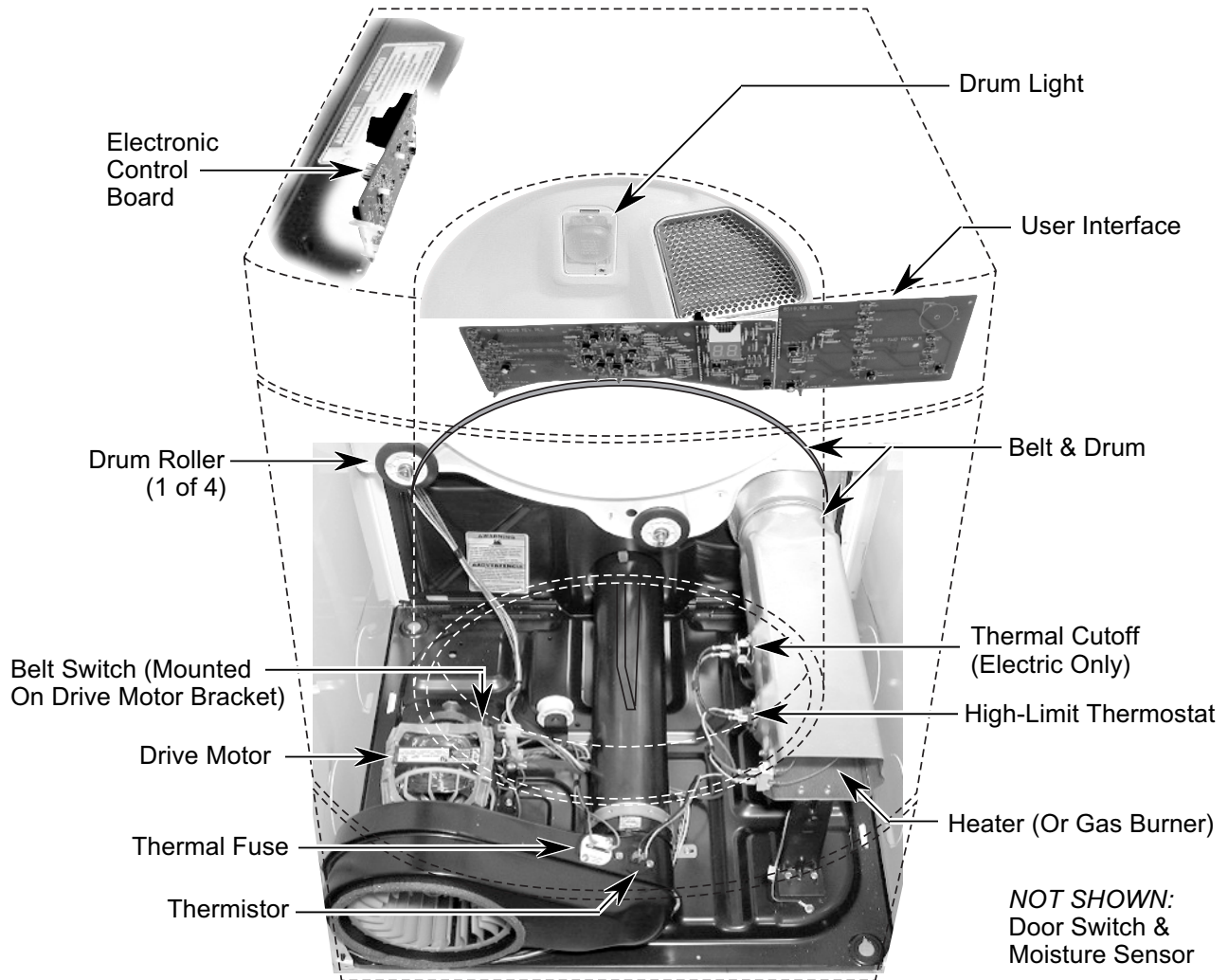

REMOVING THE ELECTRONIC CONTROL BOARD

! WARNING



Electrical Shock Hazard
Disconnect power before servicing.
Replace all parts and panels before operating.
Failure to do so can result in death or electrical shock.

1. Unplug dryer or disconnect power.
2. Turn off gas supply to dryer.
3. Pull the dryer away from the wall far enough to access the back.
4. Remove the three hex-head screws from the rear flange of the dryer's top cover.
NOTE: The top cover screws have nylon flat washers on them. Be sure to use these screws when you reinstall the top cover.



Top Cover Rear Flange Screws
W/Nylon Flat Washers

5. Lift the rear of the top cover and slide it back so the tabs clear the catches on the bracket, and remove the cover from the unit. **NOTE:** Make sure that the tabs slide under the bracket catches when you reinstall the top cover.

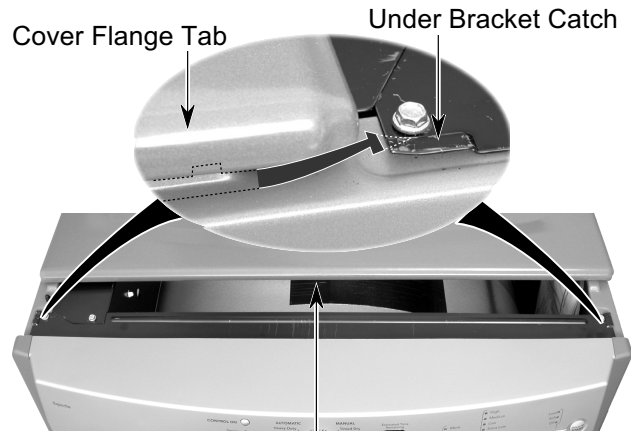

Slide Top Cover Back

6. Remove the three screws from the electronic control board bracket and pull the bracket away from the side of the dryer so you can access the connectors.

Electronic Control Board Bracket

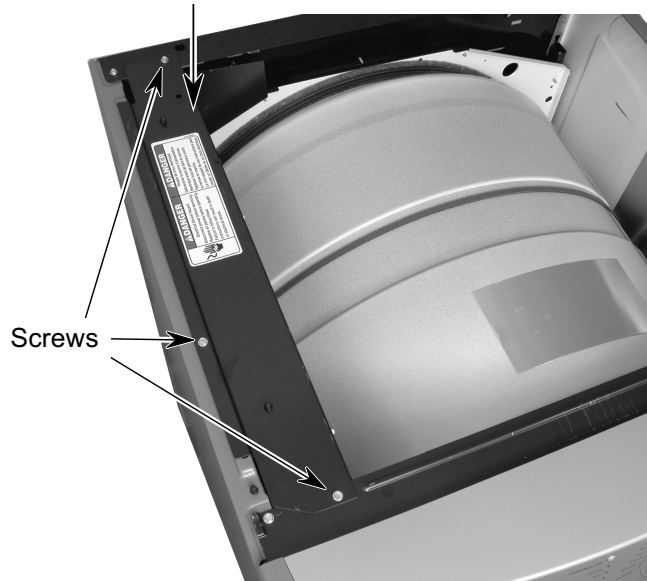

7. Disconnect the 3-wire connector from the main harness.

8. Remove the following connectors and wires from the electronic control board:
5-wire connector at P1.
Red and black wires at relay K1.
7-wire connector at P2.
Ribbon cables at P3 and P4.

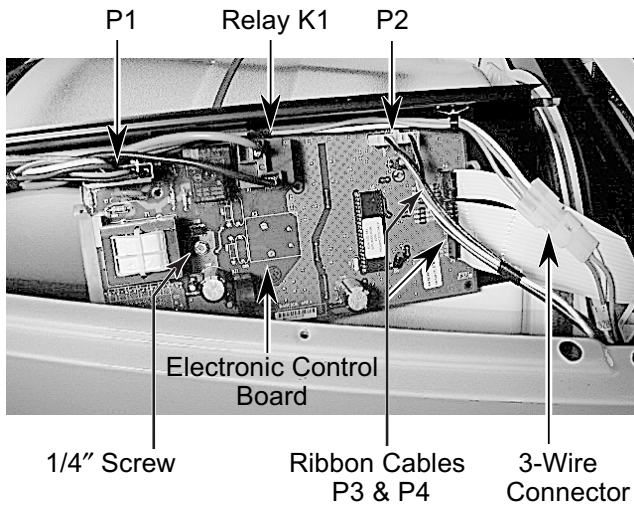

9. Remove the 1/4" hex-head screw from the electronic control board.

10. Squeeze the two board supports and remove the electronic control board from the bracket.

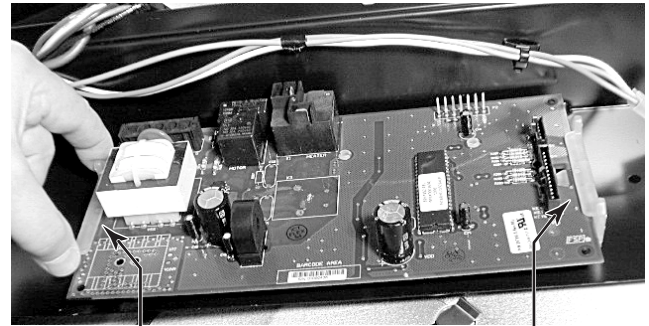

Squeeze Ends Of Supports To Remove Board

REMOVING THE CONSOLE & THE TOUCHPAD SUBASSEMBLY

⚠ WARNING



Electrical Shock Hazard

**Disconnect power before servicing.
Replace all parts and panels before
operating.**

**Failure to do so can result in death or
electrical shock.**

1. Unplug dryer or disconnect power.
2. Turn off gas supply to dryer.
3. Pull the dryer away from the wall and remove the top cover (see steps 4 and 5 on page 4-2 for the procedure).
4. Remove the three screws from the electronic control board bracket, and tip the bracket assembly inside the dryer (see step 6 on page 4-2 for the procedure).
5. Disconnect the ends of the two ribbon cables from the electronic control board connectors P3 and P4.

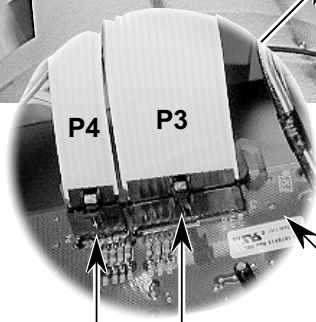
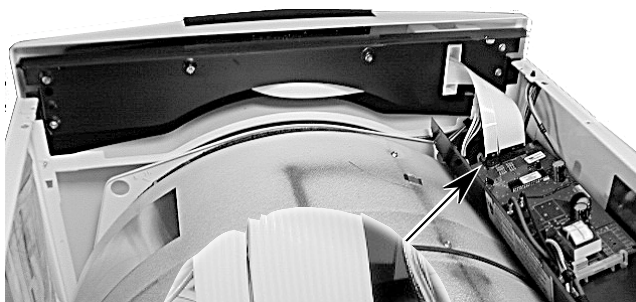

Press In On Clips To
Release Cables

Electronic
Control
Board

6. Remove the two screws from the console bracket.



Console Bracket Screws

7. Open the door and pull out on the bottom of the console to release the locking tabs from the door panel.



8. Lift the console straight up until the brackets are free of the left and right side panel flanges and remove the console.

Viewed From Back Of Console

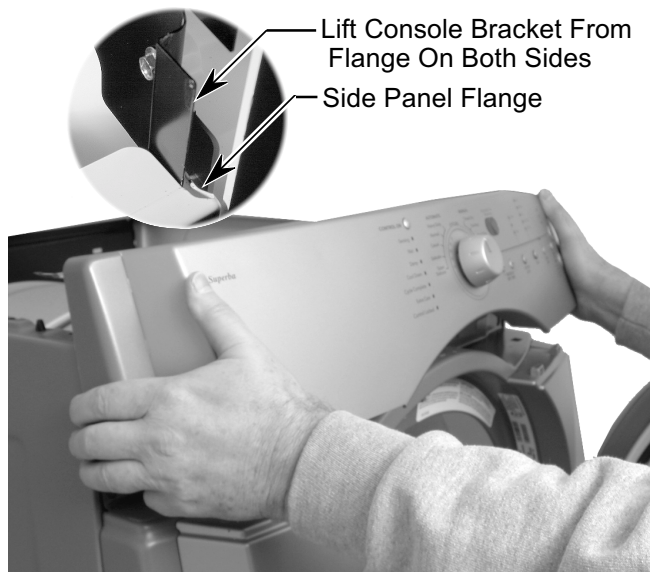

- Place the console assembly on a padded work surface with the bracket side facing up, as shown in step 10.
- Remove the four hex-head screws from the console bracket and remove the bracket.

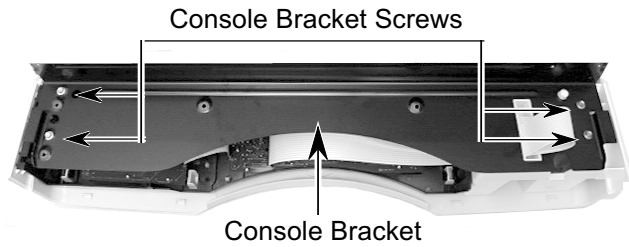

- Remove the selector knob.
- Remove the touchpad subassembly from the console by unsnapping the six catches. Use your thumb or a screwdriver.

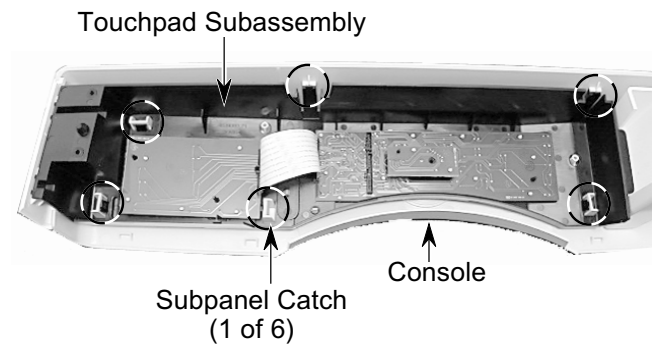
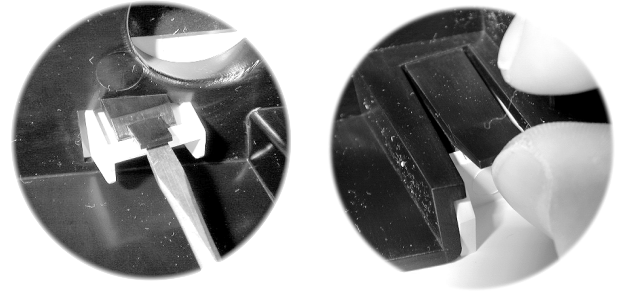

REMOVING THE DOOR SWITCH

!WARNING



Electrical Shock Hazard
Disconnect power before servicing.
Replace all parts and panels before operating.
Failure to do so can result in death or electrical shock.

1. Unplug dryer or disconnect power.
2. Turn off gas supply to dryer.
3. Pull the dryer away from the wall and remove the top cover (see steps 4 and 5 on page 4-2 for the procedure).
4. Remove the console (see page 4-4 for the procedure). Tip the console back and lay it on a padded surface.
5. Push the wire holder out of the chassis hole.
6. Press a screwdriver blade against the locking arms on each side of the door switch, (from behind the cutout), and push the switch out.
7. Disconnect the wires from the door switch terminals.

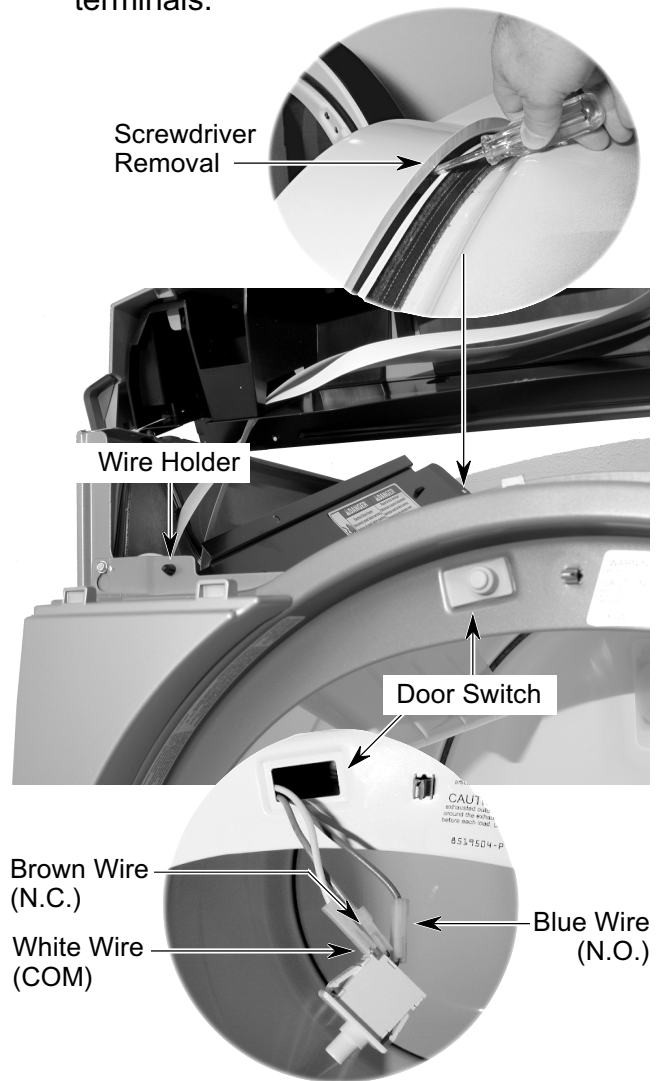

REMOVING THE THERMAL FUSE, THERMISTOR, DRIVE MOTOR, & BELT SWITCH

! WARNING



Electrical Shock Hazard
Disconnect power before servicing.
Replace all parts and panels before operating.
Failure to do so can result in death or electrical shock.

1. Unplug dryer or disconnect power.
2. Turn off gas supply to dryer.
3. Open the dryer door and remove the lint filter screen, then close the door.

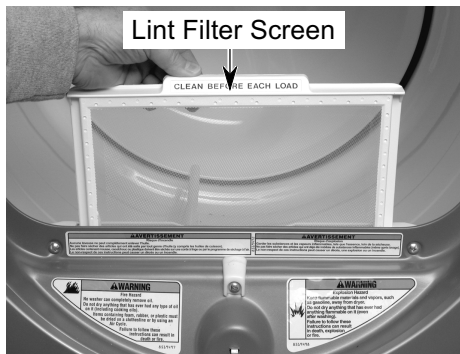

4. Remove the two hex-head screws from the bottom flange of the toe panel. Pull the panel out at the bottom, pull down, and remove the panel.

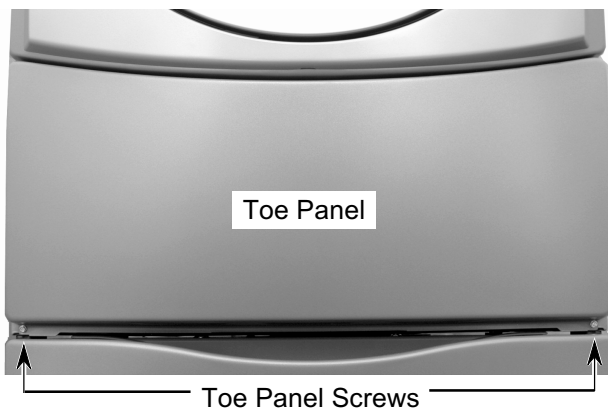

5. Remove the hex-head screw from the lint duct bracket and remove the bracket.
6. Remove the two hex-head screws from the lint duct and remove the duct.

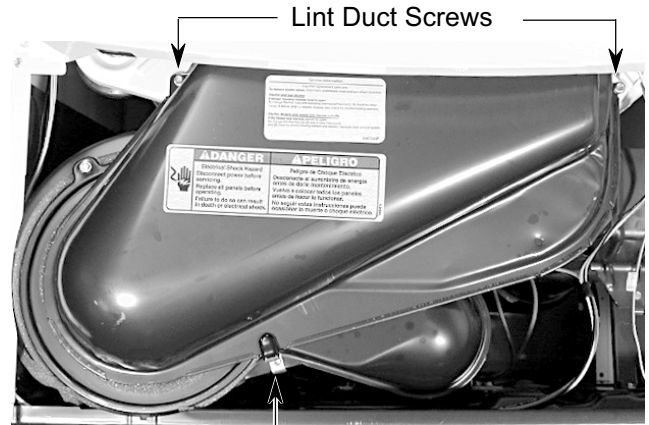

7. **To remove the thermal fuse or thermistor:**

- a) Remove the two wires from the terminals.
- b) Remove the two hex-head screws.

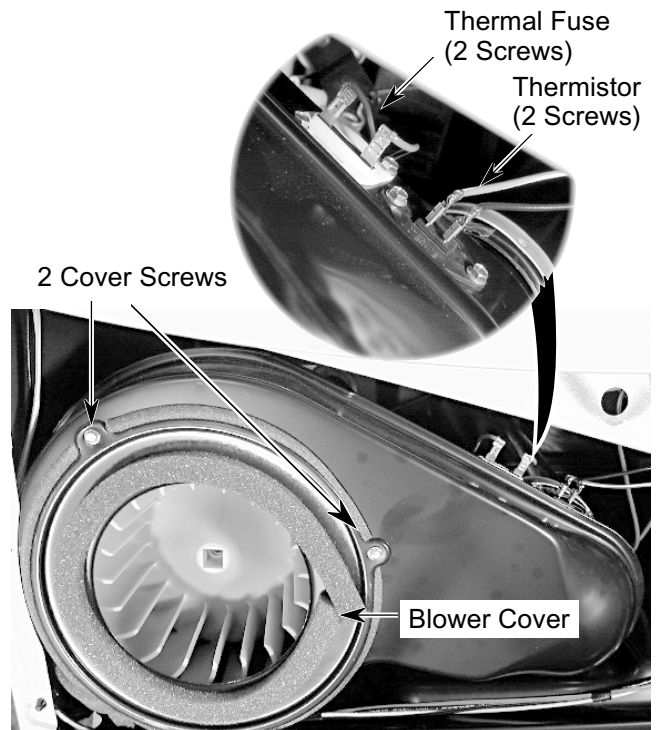

Continued on the next page.

8. **To remove the drive motor:**

- a) Remove the wires from the thermal fuse and thermistor terminals (see the photo in step 7 on page 4-7).
- b) Remove the two hex-head screws from the blower cover, and remove the cover (see the photo in step 7 on page 4-7).
- c) Reach around behind the drive motor and push the idler wheel arm to the left, then remove the tension, and remove the belt from the idler pulley.

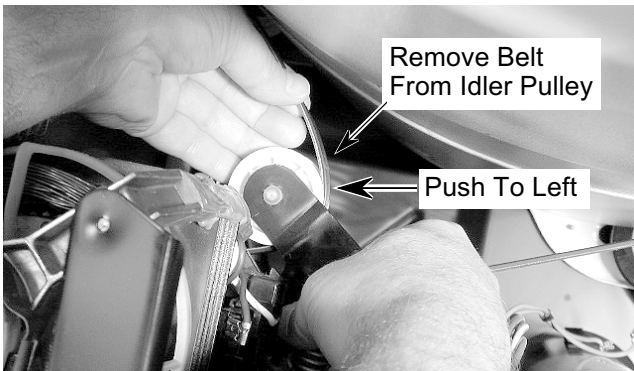

Refer to the photos at the top of the right column for the next two steps.

- d) Reach around to the back of the drive motor and attach a 7/8" open-end wrench over the hex-end of the motor shaft, and a ratchet with a 1/2" drive on the blower wheel hub.
- e) Turn the blower wheel clockwise (shown by the "REMOVE" arrow that is embossed on the front of the wheel) and remove the wheel from the motor shaft.

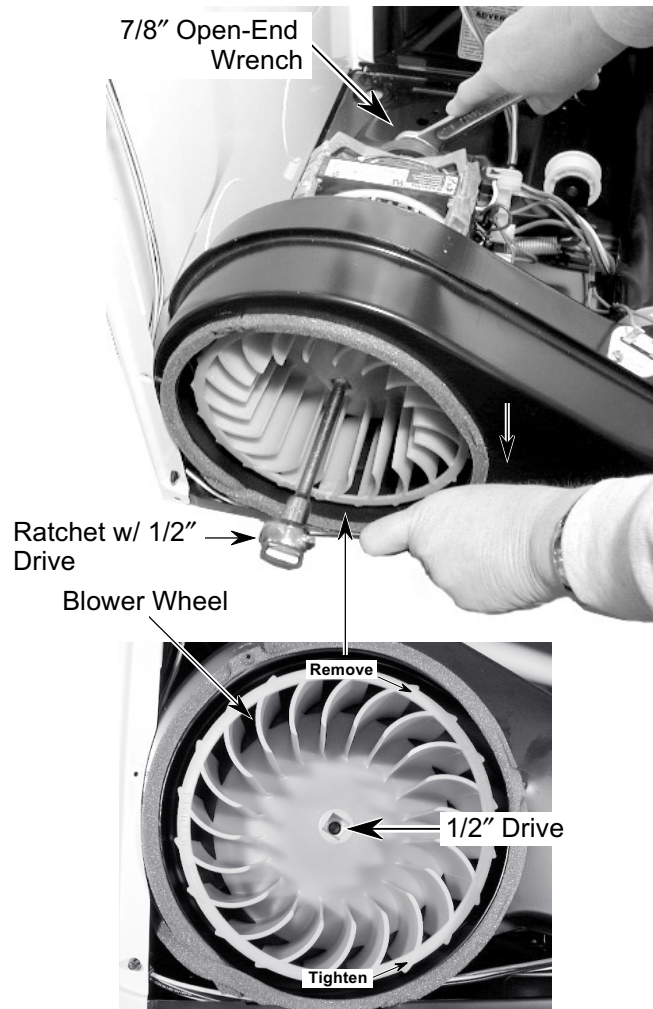

- f) Remove the three hex-head screws from the blower housing and remove it.

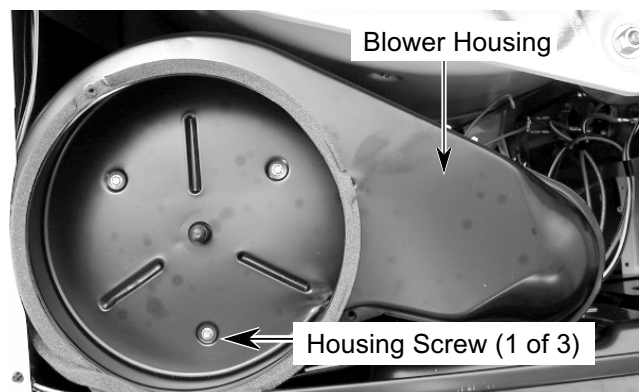

- g) Lift the top locking tab of the motor harness plug and pull the top pins away from the motor connector, then release the bottom tab, and remove the plug.

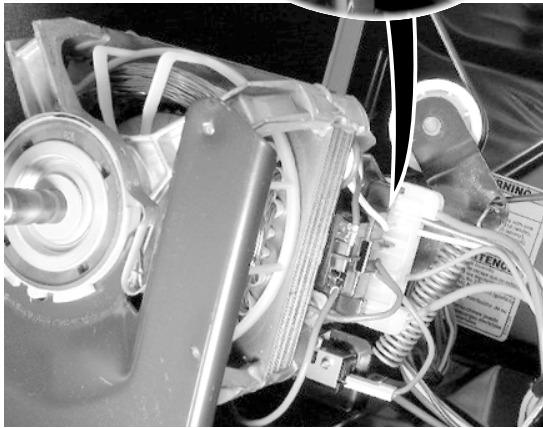
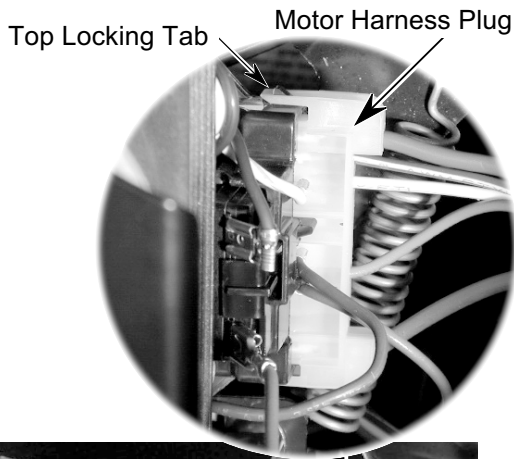

- h) Remove the two hex washer-head mounting screws from the drive motor, then lift the right side of the motor slightly, pull the two tabs on the left side out of the chassis slots, and remove the drive motor.



9. **To remove the belt switch:**

- a) Remove the 3/8" hex shoulder-washer screw from the idler pulley assembly and remove the assembly.

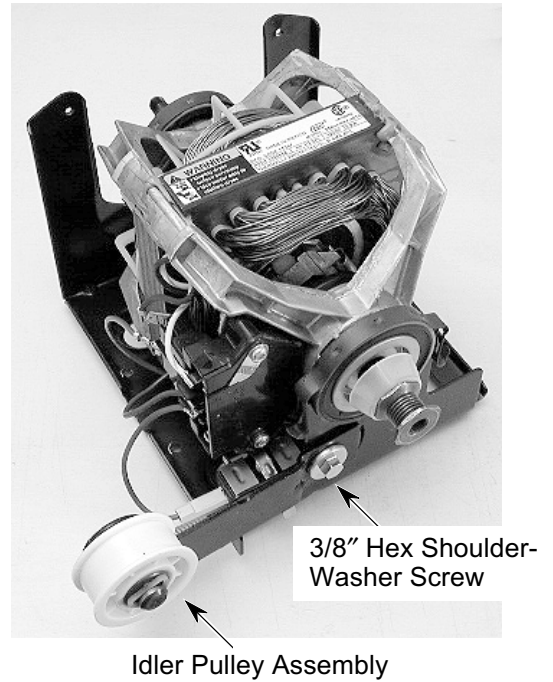

- b) Remove the two screws from the belt switch and remove it from the motor.

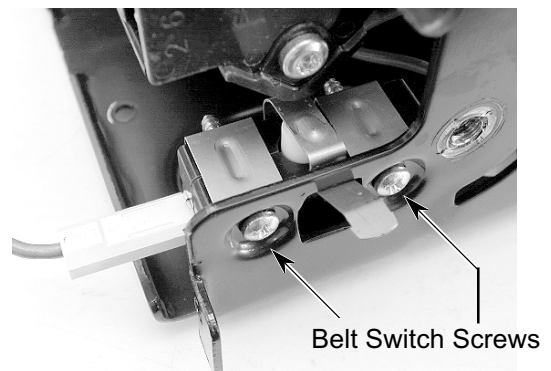

- c) Disconnect the blue wires from the belt switch terminals.

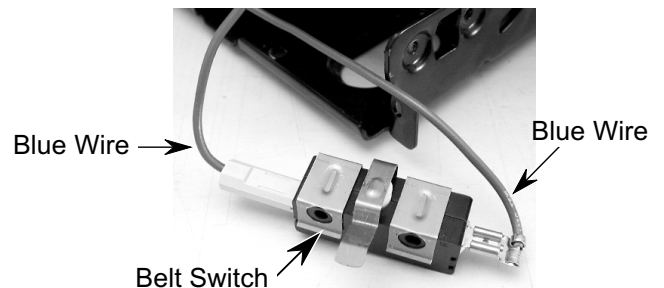

REMOVING THE HEATER, THE HIGH-LIMIT THERMOSTAT, & THERMAL CUTOFF (ELECTRIC DRYERS ONLY)

!WARNING



Electrical Shock Hazard
Disconnect power before servicing.
Replace all parts and panels before operating.
Failure to do so can result in death or electrical shock.

1. Unplug dryer or disconnect power.
2. Remove the two hex-head screws from the bottom flange of the toe panel. Pull the panel out at the bottom, pull down, and remove the panel.

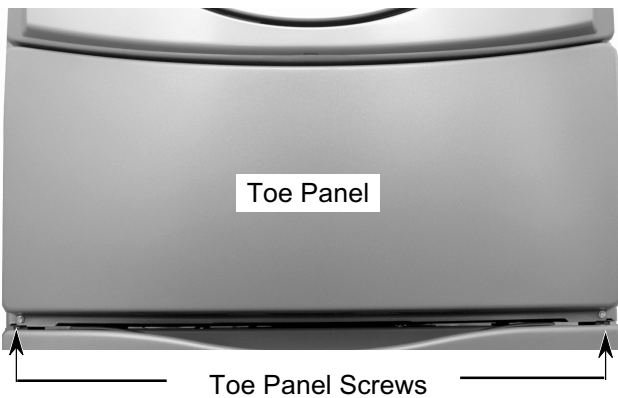

3. Remove the hex-head screw from the heater shield and remove the shield.

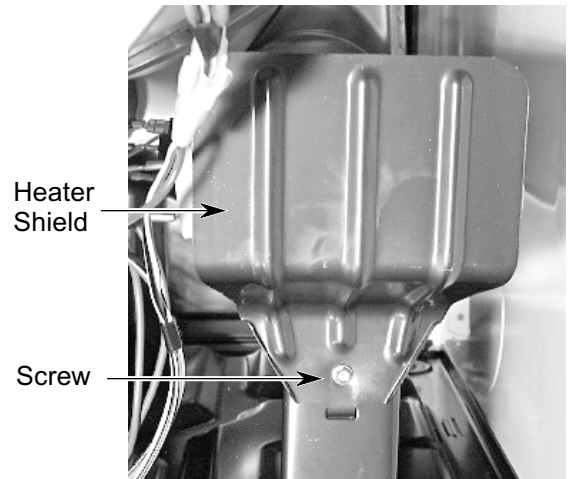

4. **To remove the heater:**
 - a) Remove the two wires from the terminal block (see photo in step 5).
 - b) Remove the hex-head screw from the heater housing, and slide the heater out of the duct.



5. **To remove the high-limit thermostat or the thermal cutoff:**

- a) Disconnect the wires from the high-limit thermostat or the thermal cutoff.
- b) Remove the two hex-head screws.

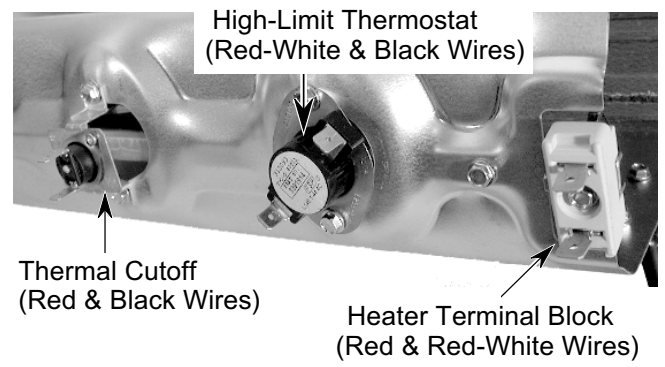

REMOVING THE BELT, DRUM, & ROLLERS

!WARNING



Electrical Shock Hazard
Disconnect power before servicing.
Replace all parts and panels before operating.
Failure to do so can result in death or electrical shock.

1. Unplug dryer or disconnect power.
2. Turn off gas supply to dryer.
3. Pull the dryer away from the wall and remove the top cover (see steps 4 and 5 on page 4-2 for the procedure).
4. Remove the console (see page 4-4 for the procedure).
5. Remove the lint duct (see steps 3 through 6 on page 4-7 for the procedure).
6. Reach around behind the drive motor and push the idler wheel arm to the left, then remove the tension, and remove the belt from the idler pulley.

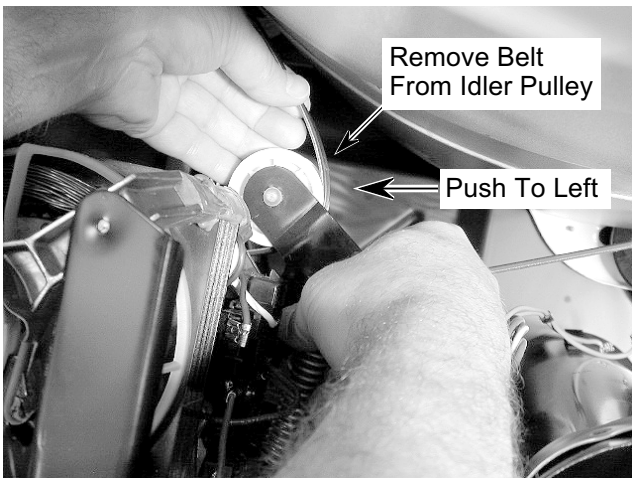

7. Disconnect the 3-wire moisture sensor connector from the main harness connector.

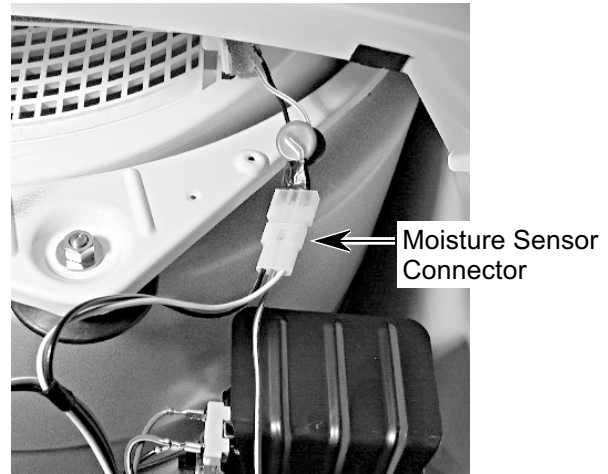

8. Disconnect the 3-wire door switch connector from the electronic control board connector.



9. Loosen the two top front panel screws.



10. Remove the two bottom front panel screws.



11. To remove the belt and drum:

a) Grasp the sides, lift, and pull the front panel forward so that the top screws are free of the keyhole slots. Lower the panel so that the drum sits on the components inside the cabinet, and slide the front panel and rollers away from the drum.

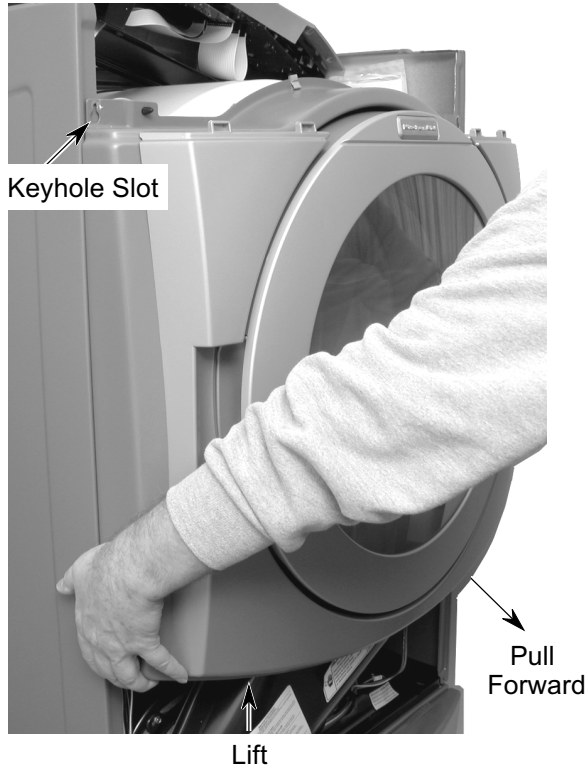

b) Slide the belt off the drum.

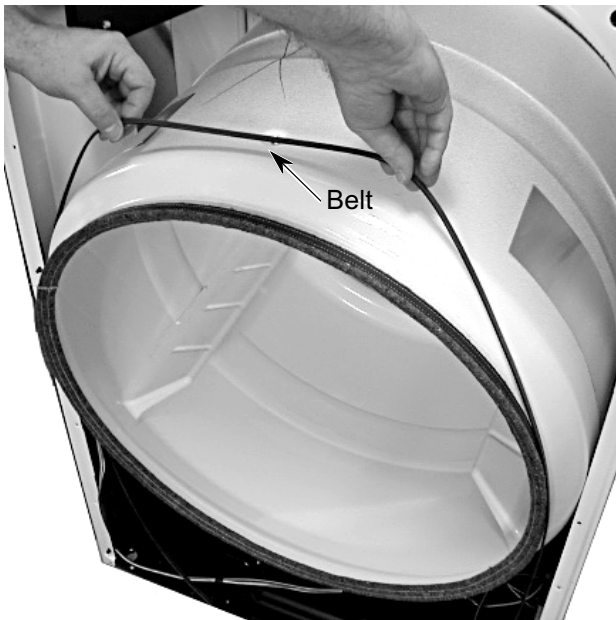

c) Lift the drum and remove it from the unit.



REASSEMBLY NOTE: Use the following illustration as a guide when installing a new belt.

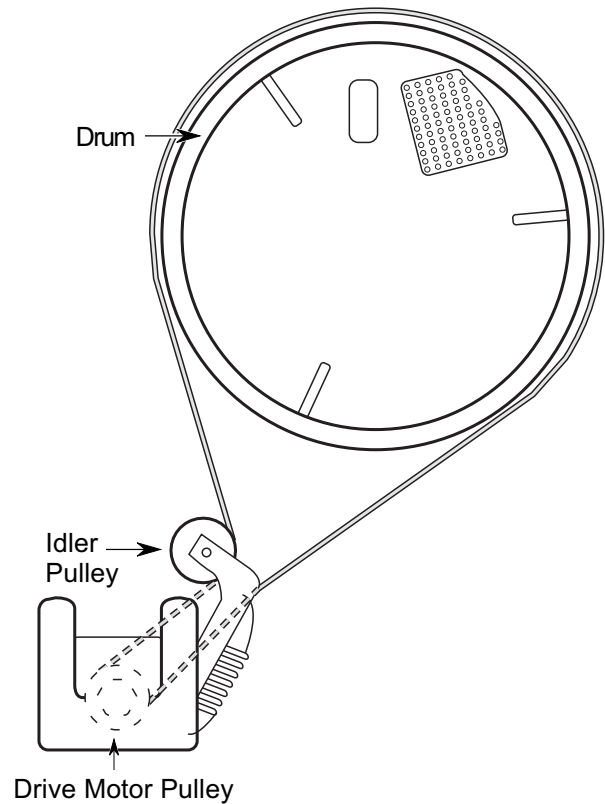

Continued on the next page.

DRUM INSTALLATION NOTE: Be sure to position the drum with the clip toward the front when you reinstall it.

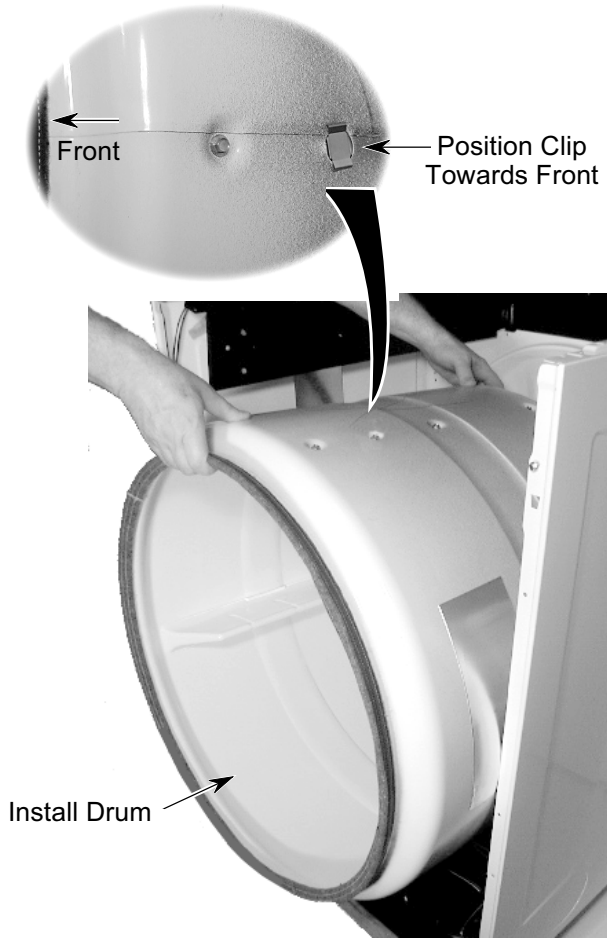

NOTE: There are two rollers on the front panel and two on the rear panel, as shown below.

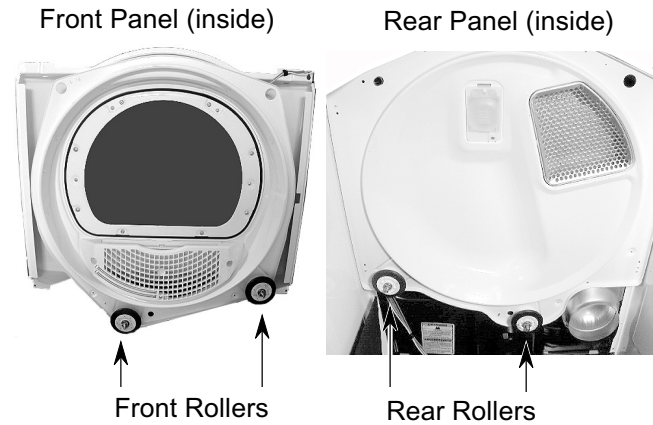

12. To remove a roller:

- a) Pry the sides of the triangular ring out of the groove in the roller support with a small screwdriver.

Triangular Ring (Partially Removed)

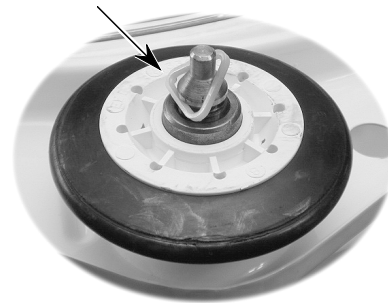

- b) Slide the roller off the roller support.

Roller Support

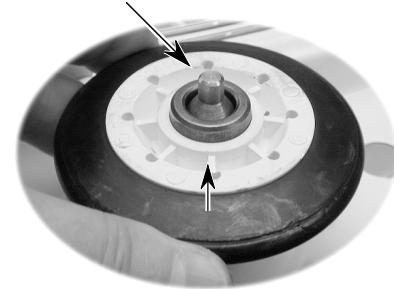

REMOVING THE DRUM LIGHT SOCKET

!WARNING



Electrical Shock Hazard
Disconnect power before servicing.
Replace all parts and panels before operating.
Failure to do so can result in death or electrical shock.

1. Unplug dryer or disconnect power.
2. Turn off gas supply to dryer.
3. Open the dryer door.
4. Remove the screw from the drum light lens and remove the lens.

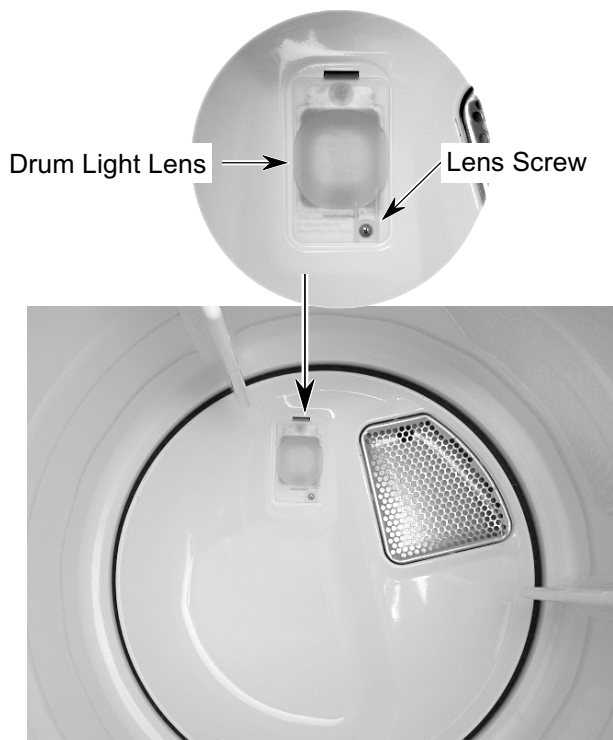

5. Remove the bulb from the drum light socket.
6. Remove the screw from the drum light holder and pull it forward so you can access the wires.

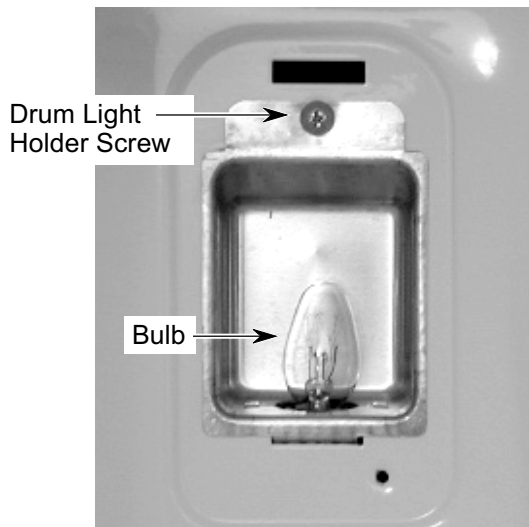

7. Disconnect the wire connectors from the light socket terminals.

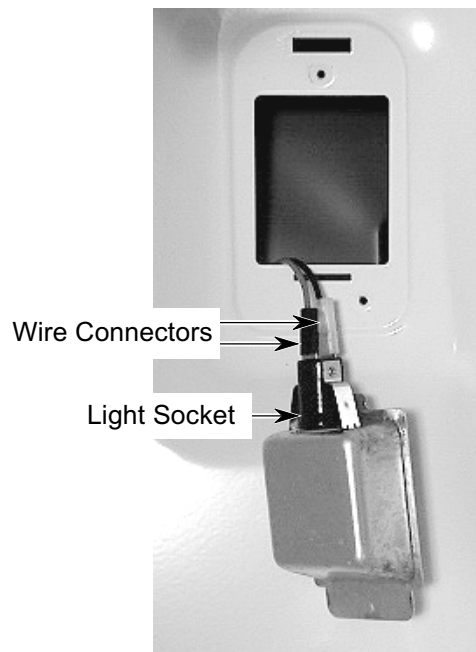

Continued on the next page.

8. Squeeze the locking arms and remove the socket from the drum light holder.

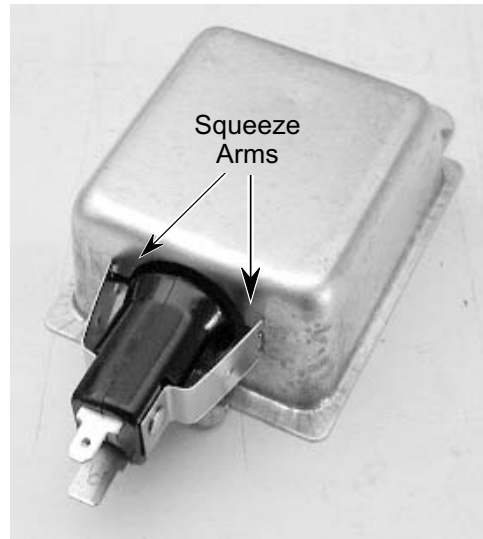

REMOVING THE MOISTURE SENSOR

!WARNING



Electrical Shock Hazard
Disconnect power before servicing.
Replace all parts and panels before operating.
Failure to do so can result in death or electrical shock.

1. Unplug dryer or disconnect power.
2. Turn off gas supply to dryer.
3. Open the dryer door and remove the lint filter screen.
4. Remove the two front screws from the outlet grille.



5. Remove the three inside screws from the outlet grille.

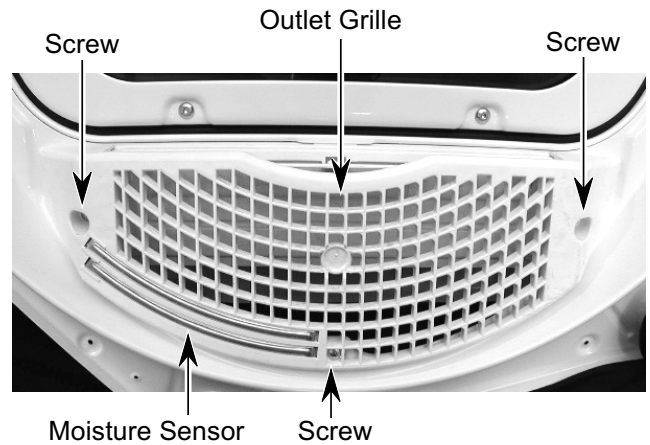

6. Pull the moisture sensor away from the dryer and disconnect the black and yellow-red wires from the moisture sensor strips.

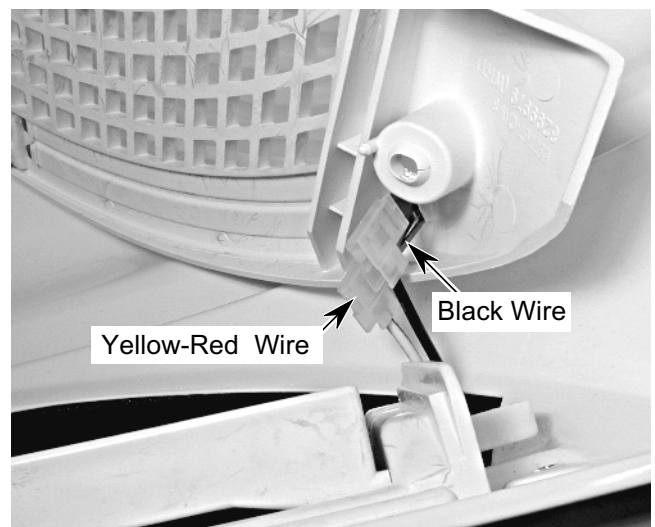

REMOVING THE BURNER ASSEMBLY, FLAME SENSOR, AND HIGH-LIMIT THERMOSTAT (GAS DRYERS ONLY)

! WARNING



Electrical Shock Hazard
Disconnect power before servicing.
Replace all parts and panels before
operating.
Failure to do so can result in death or
electrical shock.

1. Unplug dryer or disconnect power.
2. Turn off gas supply to dryer.
3. Remove the two hex-head screws from the bottom flange of the toe panel. Pull the panel out at the bottom, pull down, and remove the panel.

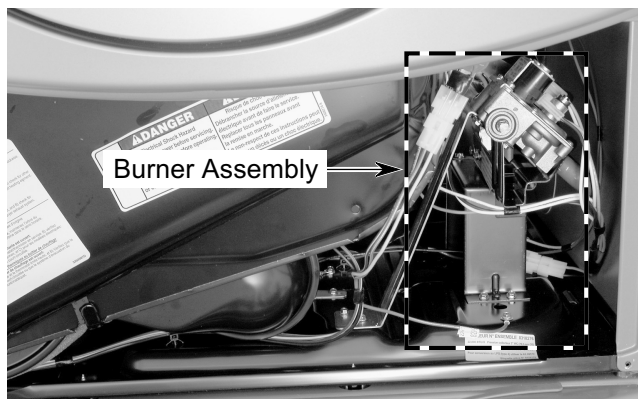
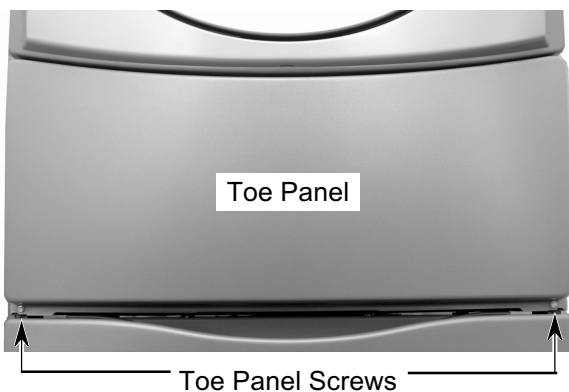

4. **To remove the burner assembly:**
 - a) Remove the two hex-head screws from the burner support bracket, and pull the bracket away from the burner assembly.

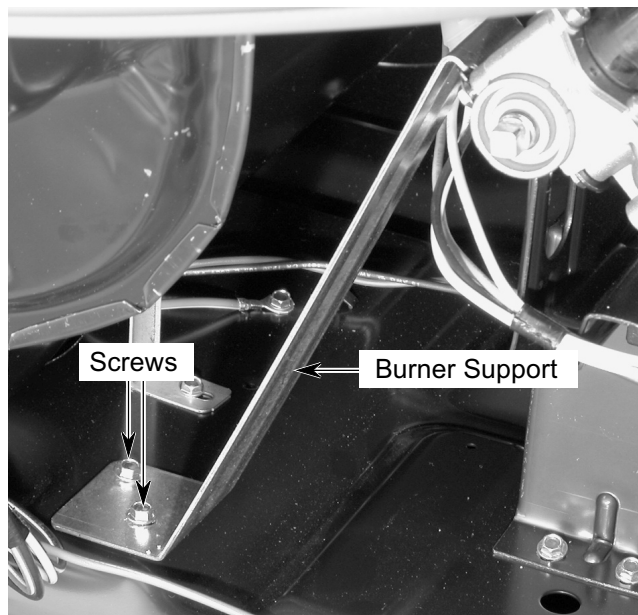

- b) Disconnect the following wires from the burner assembly:
- Blue and white wires from the flame sensor terminals.
 - 2-wire connector from the ignitor.
 - 2-wire and 3-wire connectors from the coil assembly.

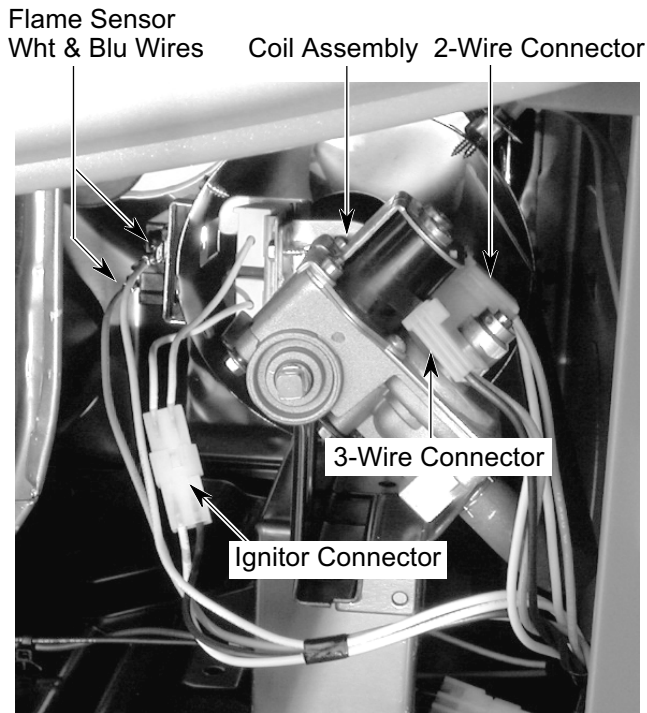

- c) Disconnect the gas line from the burner manifold at the right rear corner of the dryer.
- d) Loosen the burner manifold clamp at the inside back of the dryer.



- e) Remove the two hex-head screws from the burner mounting bracket, and pull the burner assembly out of the unit.

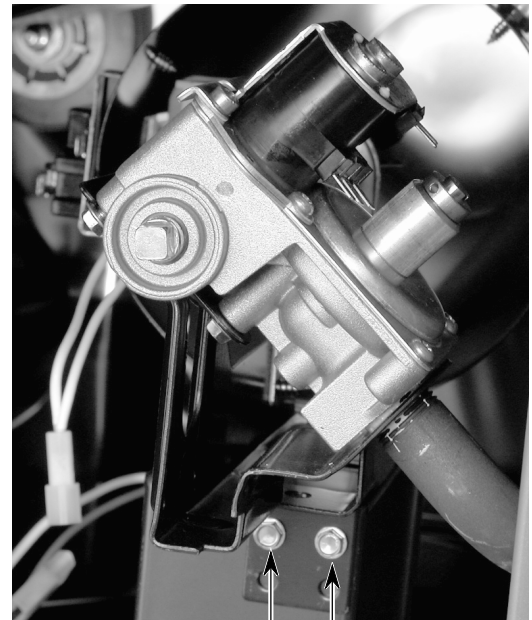

Bracket Screws

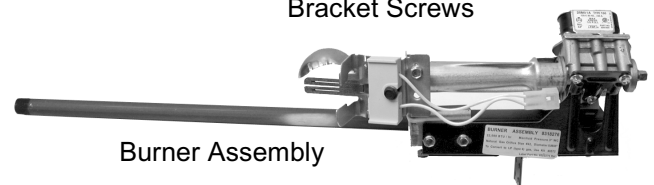

- f) **To remove the ignitor** from the burner assembly, loosen the 5/16" hex-head screw, and remove the ignitor from the mounting bracket.

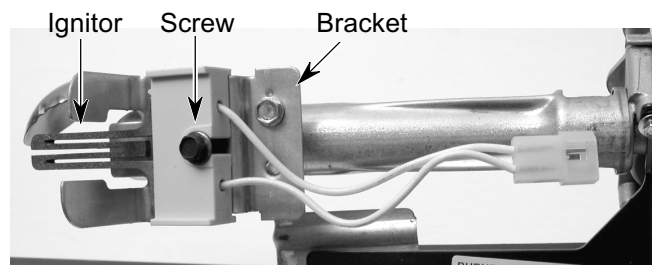

Continued on the next page.

- g) To remove the coils from the burner assembly, remove the two screws from the bracket, and lift the two coils off the cores.

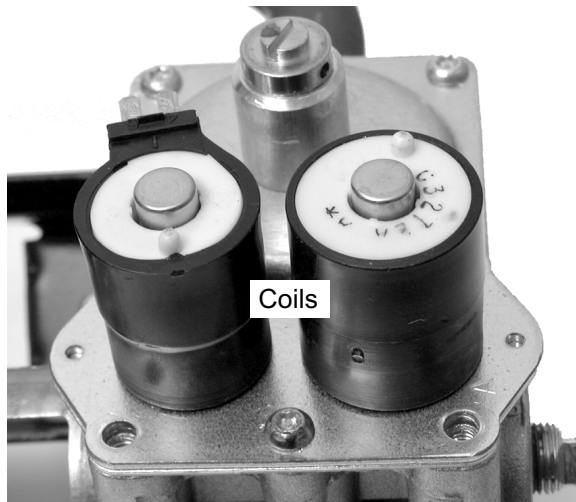
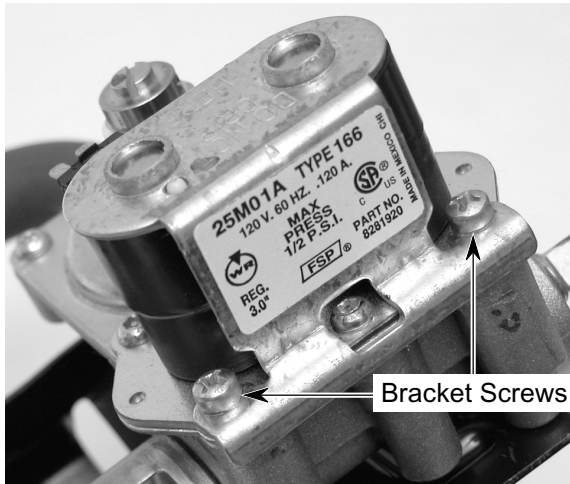

5. To remove the flame sensor:

- a) Remove the two hex-head screws from the venturi and pull it forward so you can access the flame sensor.

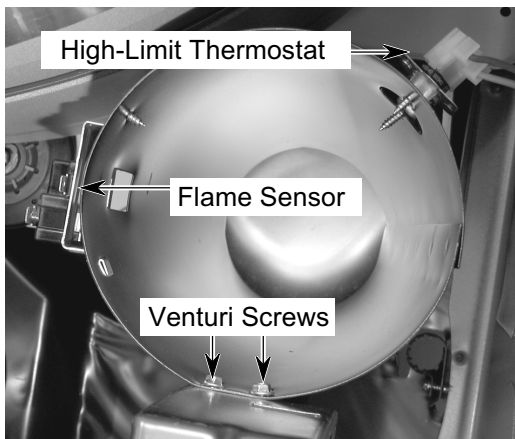

- b) Remove the hex-head screw from the flame sensor and remove the sensor from the venturi.

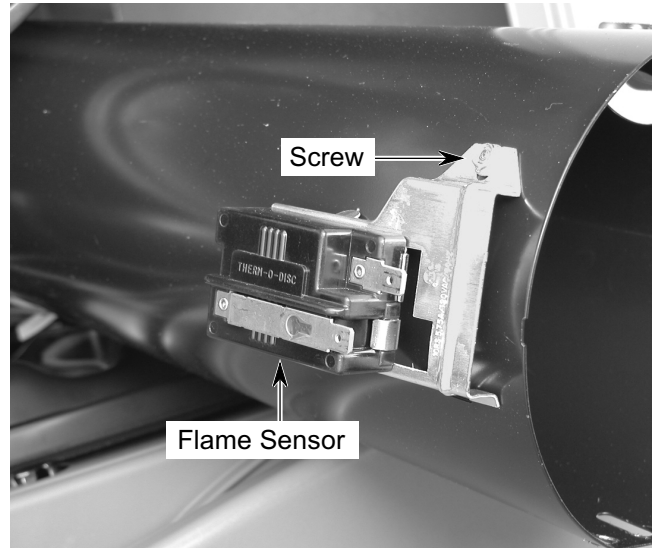

6. To remove the high-limit thermostat:

- a) Remove the venturi (see step 5).
 b) Disconnect the two wire connectors from the high-limit thermostat.
 c) Remove the two hex-head screws from the high-limit thermostat and remove the thermostat.

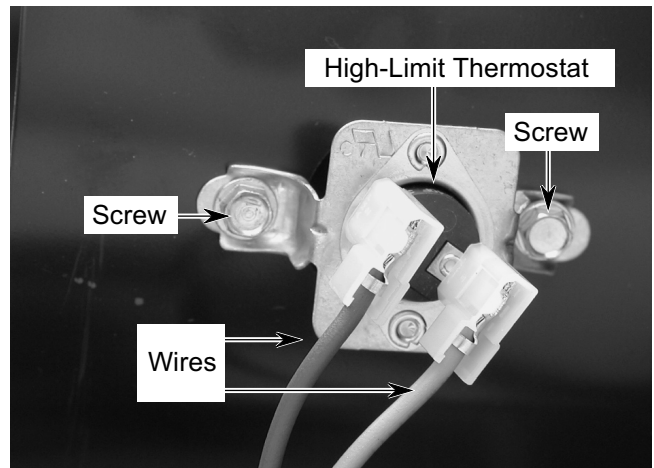

COMPONENT TESTING

Before testing any of the components, perform the following checks:

- Control failure can be the result of corrosion on connectors. Therefore, disconnecting and reconnecting wires will be necessary throughout test procedures.
- All tests/checks should be made with a VOM or DVM having a sensitivity of 20,000 ohms-per-volt DC, or greater.
- Check all connections before replacing components, looking for broken or loose wires, failed terminals, or wires not pressed into connectors far enough.
- Resistance checks must be made with power cord unplugged from outlet, and with wiring harness or connectors disconnected.

For any additional test beyond what is covered in this Component Testing section, refer to the

Tech Sheet that is supplied with the product.

	⚠ WARNING
	Electrical Shock Hazard
	Disconnect power before servicing. Replace all parts and panels before operating. Failure to do so can result in death or electrical shock.

HEATER

Refer to page 4-10 for the procedure for servicing the heater.

1. Unplug dryer or disconnect power.
2. Disconnect one of the wire connectors from the heater terminal block.
3. Set the ohmmeter to the R X 1 scale.
4. Touch the ohmmeter test leads to the terminals on the heater terminal block. The meter should indicate between 7 and 12 Ω .

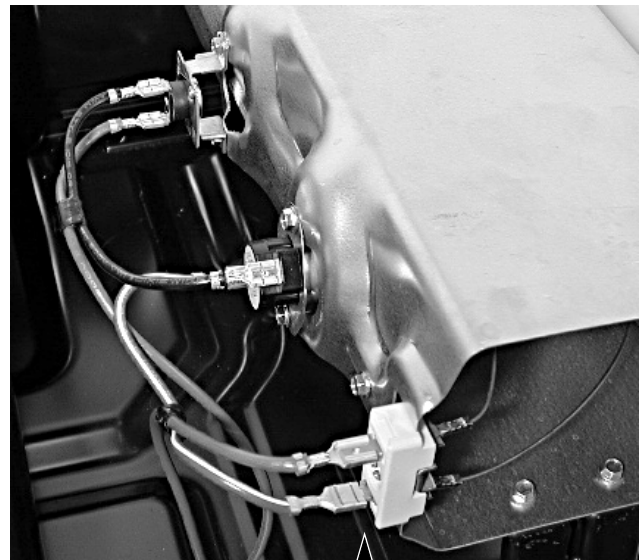

Heater Terminal Block



⚠️ WARNING

Electrical Shock Hazard

Disconnect power before servicing.

Replace all parts and panels before operating.

Failure to do so can result in death or electrical shock.

DRIVE MOTOR

Refer to page 4-7 for the procedure for servicing the drive motor.

1. Unplug dryer or disconnect power.
2. Turn off gas supply to dryer.
3. Disconnect the plug from the motor connector.
4. Set the ohmmeter to the R X 1 scale.
5. Touch one ohmmeter test lead to the blue motor wire connector, and the other test lead to connector pin 5 (white-orange wire). The meter should indicate between 2.4 and 3.6 Ω (main winding).

6. Touch one ohmmeter test lead to the blue motor wire connector, and the other test lead to connector pin 3 (violet wire). The meter should indicate between 2.4 and 3.8 Ω (start winding).
7. If either resistance is much larger than 4 Ω , replace the motor.

If the resistances at the motor are correct, check for a failed belt switch.

If the belt switch is okay, check for an open circuit between the motor and the electronic control board.

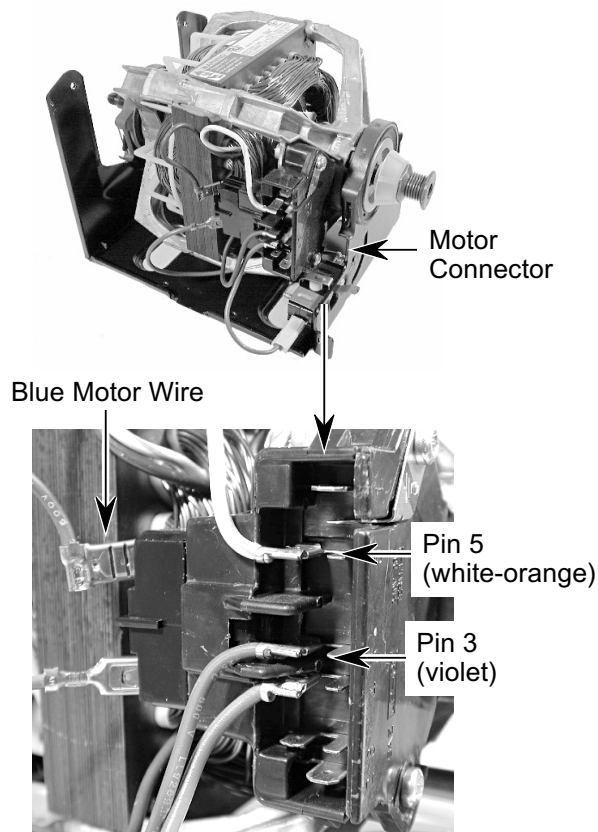



⚠ WARNING

Electrical Shock Hazard

Disconnect power before servicing.

Replace all parts and panels before operating.

Failure to do so can result in death or electrical shock.

THERMAL FUSE

Refer to page 4-7 for the procedure for servicing the thermal fuse.

Electric Dryers: The thermal fuse is wired in series with the drive motor. If the thermal fuse opens, 91°C (196°F), power to the motor is turned off. A centrifugal switch on the motor also opens the heater circuit.

Once the thermal fuse has opened, it will not reset, and must be replaced. Check for a failed thermistor, or a shorted heater element.

Gas Dryers: The thermal fuse is wired in series with the gas valve. If the thermal fuse opens, 91°C (196°F), power to the valve is turned off. A centrifugal switch on the motor also opens the heater circuit.

Once the thermal fuse has opened, it will not reset, and must be replaced. Check for a failed thermistor.

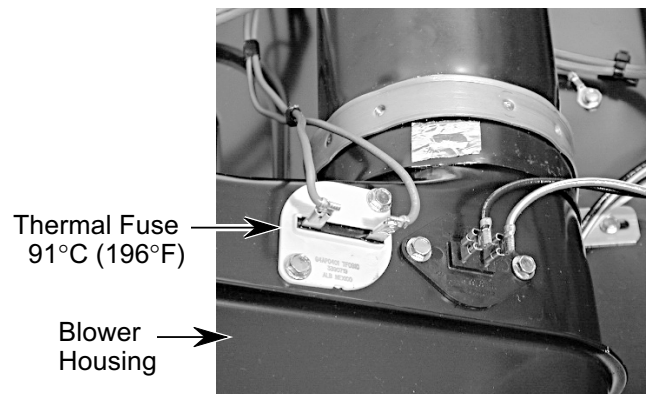

1. Unplug dryer or disconnect power.
2. Turn off gas supply to dryer.
3. Disconnect the wires from the thermal fuse.
4. Set the ohmmeter to the R X 1 scale.
5. Touch the ohmmeter test leads to the thermal fuse terminals. The meter should indicate continuity (0Ω). If the meter indicates an open circuit (infinite), replace the thermal fuse.

THERMISTOR

Refer to page 4-7 for the procedure for servicing the thermistor.

The thermistor monitors the exhaust temperature. The changes in thermistor resistance signals the electronics control, which cycles the high-limit thermostat on and off to maintain the desired temperature.

1. Turn the dryer off but keep the electrical supply connected.
2. Make sure that the dryer is empty and that the lint screen is clean.
3. Close the dryer door.
4. Select *Heavy Duty*, *Timed Dry*, + or –, *Cycle End Signal (Loud)*, and *Start*.
5. If error codes **E1** or **E2** flash on the display after 1 minute and the dryer turns off, the thermistor, or the wire harness, is either shorted or open. Check the wire connections at the thermistor or the electronic control board. If wiring checks okay, replace the thermistor.
6. If the dryer seems to operate normally, remove the exhaust vent and start the dryer.
7. Select the desired temperature cycle to be tested, and select 20 minutes of *Timed Dry* heat using the + or – pushbuttons.

8. Hold a glass bulb thermometer capable of reading from 32°C to 82°C (90°F to 180°F) in the center of the exhaust outlet. Measure the exhaust temperatures with the heater on and off. The correct exhaust temperatures for the various settings are shown in the following chart.

TEMPERATURE SETTING	HEAT TURNS OFF	HEAT TURNS ON
HIGH	68° C ±6° (155° F ±10°)	6 - 8°C (10 - 15°F)
MEDIUM	60° C ±6° (140° F ±10°)	below the heat
LOW	52° C ±6° (125° F ±10°)	turn off
EXTRA LOW	41° C ±3° (105° F ±5°)	temperature

9. If the exhaust temperature is not within the specified limits, check the resistance of the thermistor, as shown in the following chart. If the resistance is okay, replace the electronic control board.

THERMISTOR RESISTANCE			
TEMP °C (°F)	RESISTANCE (K Ω)	TEMP °C (°F)	RESISTANCE (K Ω)
10° (50°)	19.9	43° (110°)	4.7
16° (60°)	15.3	49° (120°)	3.7
21° (70°)	11.9	54° (130°)	3.1
27° (80°)	9.2	60° (140°)	2.5
32° (90°)	7.4	66° (150°)	2.1
38° (100°)	5.7	71° (160°)	1.7



⚠️ WARNING

Electrical Shock Hazard

Disconnect power before servicing.

Replace all parts and panels before operating.

Failure to do so can result in death or electrical shock.

THERMAL CUTOFF (ELECTRIC DRYERS ONLY)

Refer to page 4-10 for the procedure for servicing the thermal cutoff.

The thermal cutoff is a non-resettable device. The cutoff temperature is 178°C (352°F).

If the dryer does not heat and there is 240 VAC to the dryer, perform the following test.

1. Unplug dryer or disconnect power.
2. Disconnect the wires from the thermal cutoff.
3. Set the ohmmeter to the R X 1 scale.
4. Touch the ohmmeter test leads to the thermal cutoff terminals. The meter should indicate continuity (0Ω). If the meter indicates an open circuit (infinite), replace both the thermal cutoff and the high-limit thermostat. In addition, check for a failed heater element, or a blocked, or improper exhaust system.

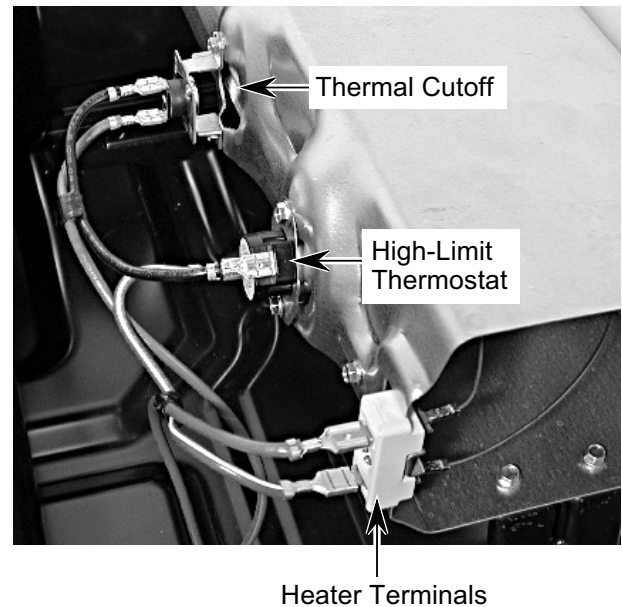

⚠ WARNING



Electrical Shock Hazard

Disconnect power before servicing.

Replace all parts and panels before operating.

Failure to do so can result in death or electrical shock.

DOOR SWITCH

Refer to page 4-6 for the procedure for servicing the door switch.

1. Set the dryer to the “Diagnostic Test Mode” (refer to the procedure on page 6-2).
2. Open and close the dryer door. You should hear a “beep” each time the door is closed and opened, and “**OE**” should be displayed in the console window whenever the door is opened.

If a beep does not sound, or if “**OE**” is displayed with the door closed, check the wiring between the door switch and the electronic control board for positive connections or short circuits.

If the wiring is okay, perform the resistance tests.

Door Switch Connector

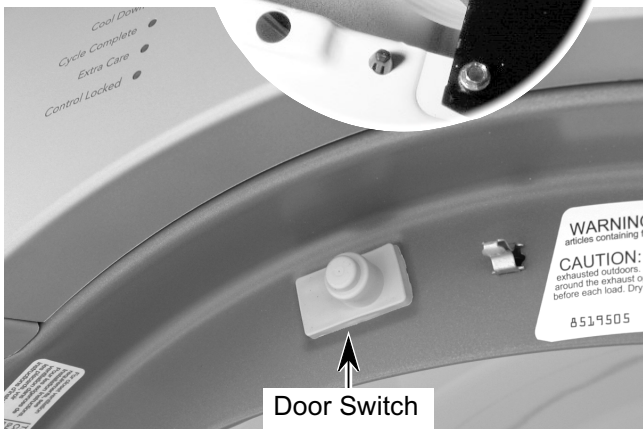

Resistance Tests

1. Unplug dryer or disconnect power.
2. Turn off gas supply to dryer.
3. Close the dryer door.
4. Disconnect the 3-wire connector from the door switch to the electronic control board.
5. Set the ohmmeter to the R X 1 scale.

Refer to the illustration below for the following tests.

6. Touch the black ohmmeter test lead to the white wire pin in the connector and leave it there for the remaining tests.
7. Touch the red ohmmeter test lead to the brown wire pin in the connector. The meter should indicate an open circuit (infinite).
8. Touch the red ohmmeter test lead to the blue wire pin in the connector. The meter should indicate a closed circuit (0 ohms).
9. Open the dryer door.
10. Touch the red ohmmeter test lead to the blue wire pin in the connector. The meter should indicate an open circuit (infinite).
11. Touch the red ohmmeter test lead to the brown wire pin in the connector. The meter should indicate a closed circuit (0 ohms).
12. If the resistance test is incorrect, replace the wire and door switch assembly, (see page 4-6 for the procedure), and retest.

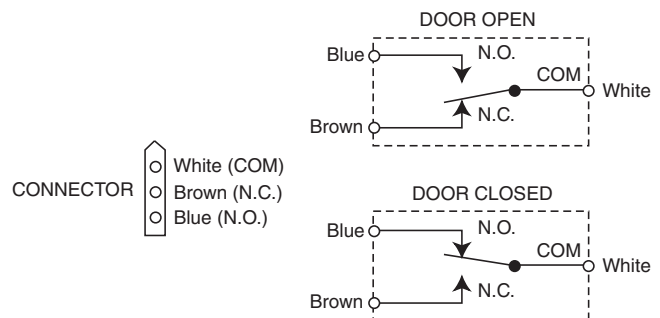



⚠ WARNING

Electrical Shock Hazard

Disconnect power before servicing.

Replace all parts and panels before operating.

Failure to do so can result in death or electrical shock.

GAS BURNER COILS

Refer to page 4-18 for the procedure for servicing the gas burner assembly.

1. Unplug dryer or disconnect power.
2. Turn off gas supply to dryer.
3. Disconnect the wire connectors from the coil terminals.
4. Set the ohmmeter to the R X 100 scale.
5. Touch the ohmmeter test leads to the 2-terminal coil. The meter should indicate between 1000 and 1300 Ω .
6. Touch the ohmmeter test leads to the 3-terminal coil. The meter should indicate as follows:

Pins 1 & 2 = 1300 to 1400 Ω

Pins 1 & 3 = 500 to 600 Ω

Pins 4 & 5 = 1200 to 1300 Ω

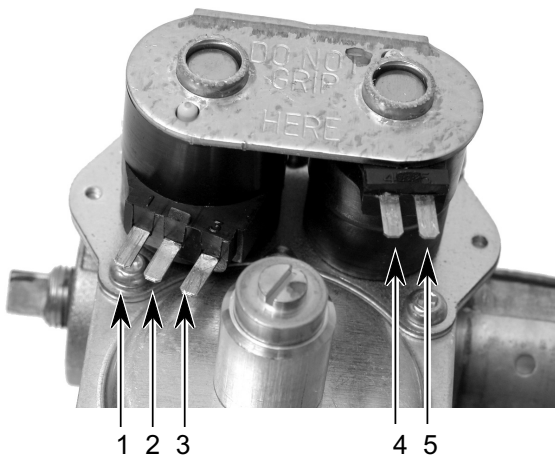

BURNER IGNITOR

Refer to page 4-18 for the procedure for servicing the gas burner assembly.

1. Unplug dryer or disconnect power.
2. Turn off gas supply to dryer.
3. Disconnect the ignitor wire connector from the main harness connector.
4. Set the ohmmeter to the R X 1 scale.
5. Touch the ohmmeter test leads to the 2-wire connector pins. The meter should indicate between 50 and 250 Ω .

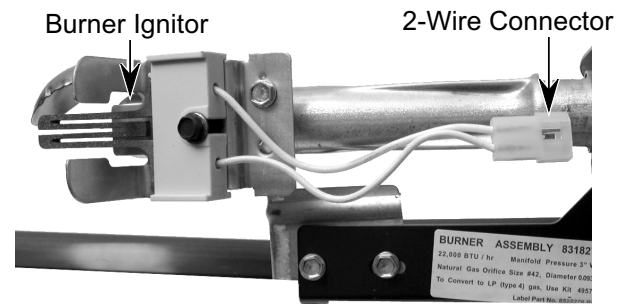



⚠️ WARNING

Electrical Shock Hazard

Disconnect power before servicing.

Replace all parts and panels before operating.

Failure to do so can result in death or electrical shock.

FLAME SENSOR

Refer to page 4-18 for the procedure for servicing the flame sensor.

1. Unplug dryer or disconnect power.
2. Turn off gas supply to dryer.
3. Disconnect the wire connectors from the flame sensor terminals.
4. Set the ohmmeter to the R X 1 scale.
5. Touch the ohmmeter test leads to the flame sensor terminals. The meter should indicate a closed circuit (0Ω).

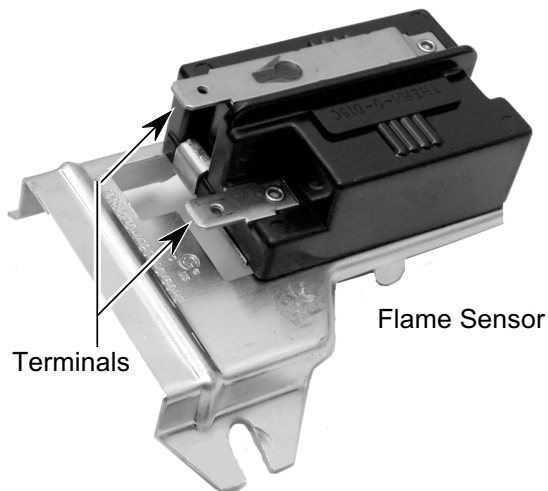

HIGH-LIMIT THERMOSTAT

Refer to pages 4-10 or 4-18 for the procedure for servicing the high-limit thermostat.

1. Unplug dryer or disconnect power.
2. Turn off gas supply to dryer.
3. Disconnect the wire connectors from the high-limit thermostat terminals.
4. Set the ohmmeter to the R X 1 scale.
5. Touch the ohmmeter test leads to the high-limit thermostat terminals. The meter should indicate a closed circuit (0Ω).

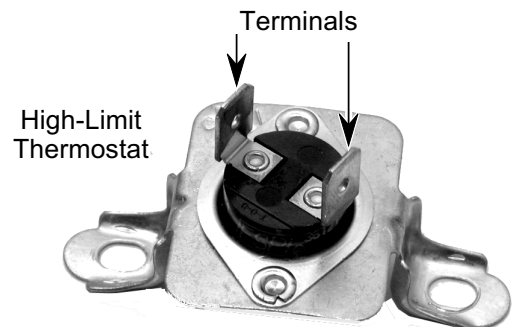

DIAGNOSTICS AND TROUBLESHOOTING

DIAGNOSTICS

! WARNING



Electrical Shock Hazard

Disconnect power before servicing.

Replace all parts and panels before operating.

Failure to do so can result in death or electrical shock.

DIAGNOSTIC GUIDE

Before servicing, check the following:

- Make sure there is power at the wall outlet.
- Has a household fuse blown or circuit breaker tripped? Time delay fuse?
- Is dryer vent properly installed and clear of lint or obstructions?
- All tests/checks should be made with a VOM or DVM having a sensitivity of 20,000 ohms per volt DC or greater.
- Check all connections before replacing components. Look for broken or loose wires, failed terminals, or wires not pressed into connectors far enough.
- The most common cause for control failure is corrosion on connectors. Therefore, disconnecting and reconnecting wires will be necessary throughout test procedures.
- Connectors: Look at top of connector. Check for broken or loose wires. Check for wires not pressed into connector far enough to engage metal barbs.
- Resistance checks must be made with power cord unplugged from outlet.

IMPORTANT

Electrostatic Discharge (ESD) Sensitive Electronics

ESD problems are present everywhere. ESD may damage or weaken the electronic control board. The new control assembly may appear to work well after repair is finished, but failure may occur at a later date due to ESD stress.

- Use an anti-static wrist strap. Connect wrist strap to green ground connection point or unpainted metal in the appliance.

-OR-

Touch your finger repeatedly to a green ground connection point or unpainted metal in the appliance.

- Before removing the part from its package, touch the anti-static bag to a green ground connection point or unpainted metal in the appliance.
- Avoid touching electronic parts or terminal contacts; handle electronic control board by edges only.
- When repackaging failed electronic control board in anti-static bag, observe above instructions.

DISPLAY FAULT/ERROR CODES

DISPLAY	DESCRIPTION	EXPLANATION AND RECOMMENDED PROCEDURE
<i>PF</i>	Power failure	“PF” flashes to indicate that a power failure occurred while the dryer was running. Press HOLD TO START to continue the cycle, or press OFF/Pause to clear the display.
<i>E1</i>	Thermistor open	“E1” flashes if the thermistor is open. See TEST #3a.
<i>E2</i>	Thermistor shorted	“E2” flashes if the thermistor has shorted. See TEST #3a.
<i>E3</i>	User interface or software mismatch	“E3” flashes when there is a keyswitch or software mismatch. This error code will ONLY appear when in the Diagnostic Test mode. See TEST #5.

DIAGNOSTIC TESTS

These tests allow factory or service personnel to test and verify all inputs to the electronic control board. It would be a good idea to perform a quick, overall checkup of the dryer with these tests before going to any specific troubleshooting tests.

Activating The Diagnostic Test Mode

1. Be sure the dryer is in the Standby Mode (plugged in and all indicators off).
2. Press the following button sequence within 5 seconds of power up:
 - + (more time)
 - (less time)
 - + (more time)
 - (less time)
3. If this test mode has been entered successfully, all indicators on the console are illuminated, with “88” showing in the “Estimated Time Remaining” (2-digit) display.

If the entry into the diagnostic mode was unsuccessful, take the following actions for specific indications:

Indication 1: None of the indicators or display turns on.

Action: Select any Manual Cycle. If the indicators turn on, then try to change the dryer time by pressing the + and – buttons. If either button fails to change the time, something is faulty with one of those buttons, and it is not possible to enter the diagnostic mode. Remove the console electronics and housing. If no indicators come on after pressing the Manual Cycle buttons, go to TEST #1 (Supply Connections) on page 6-4.

Indication 2: E1 or E2 flashes on the display.

Action: Proceed to TEST #3a (Thermistor Test) on page 6-8.

Indication 3: E3 flashes on the display.

Action: Check to make sure that the correct electronic control board, console electronics, and housing are installed.

Diagnostic: Console switches and indicators.

Pressing each button, or turning the cycle selector to each cycle, should cause a beep tone and control one or more LEDs. Pressing the Hold To Start button will also control the motor and heater, while the 2-digit display will indicate a software project identification number.

Diagnostic: Moisture Sensor

Locate the two metal strips on the face of the lint screen housing. Bridge these strips with a wet cloth or a finger. If a beep is heard, and a software revision number is displayed on the console, the sensor is okay. If not, or if a beep tone is heard before bridging the moisture strips, go to TEST #4, (Moisture Sensor Test), step 2, on page 6-10.

Diagnostic: Door Switch

Opening the door should cause a beep tone and a number and letter to be indicated in the 2-digit display. Closing the door firmly should cause a beep tone and the display to go blank, or indicate "88".

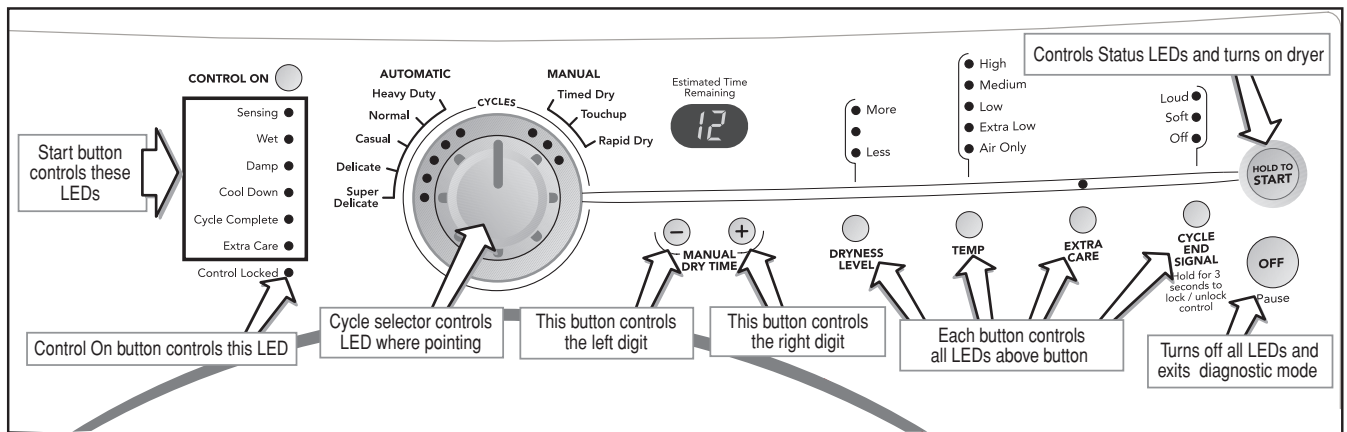

TROUBLESHOOTING

TROUBLESHOOTING GUIDE

PROBLEM	POSSIBLE CAUSE / TEST
NOTE: Possible Cause/Tests MUST be performed in the sequence shown for each problem.	
WILL NOT POWER UP. (No response when Control On button is pressed.)	1. Supply connection. See TEST #1. 2. Check harness connections. 3. Console electronics and housing. See TEST #5.
WILL NOT START CYCLE WHEN START BUTTON IS PRESSED.	1. If number display flashes, check to be sure the door is completely shut, and press and hold down HOLD TO START for about 1 second. 2. See TEST #2. 3. See TEST #6.
WILL NOT SHUT OFF WHEN EXPECTED.	1. Check OFF/Pause button. See TEST #5. 2. Console electronics and housing. See TEST #5. 3. Moisture Sensor. See TEST #4.
CONTROL WILL NOT ACCEPT SELECTIONS.	Console electronics and housing. See TEST #5.
WILL NOT HEAT.	1. Heater. See TEST #3. 2. Check harness connections. 3. Check installation.
HEATS IN AIR CYCLE.	Thermistor. See TEST #3a.
SHUTS OFF BEFORE CLOTHES ARE DRY.	Moisture Sensor. See TEST #4.

TROUBLESHOOTING TESTS

NOTE: These checks are done with the dryer unplugged or disconnected from power.

TEST #1: SUPPLY CONNECTIONS

This test assumes that proper voltage is present at the outlet.

1. Unplug dryer or disconnect power.
2. Remove the cover plate from the top right corner of the back of the dryer.

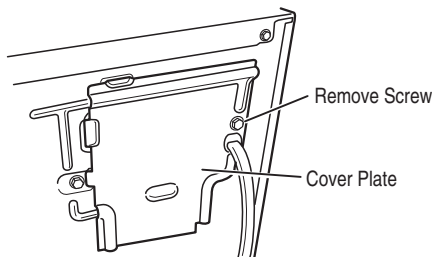

3. Gas Dryers Only:

- a) Check that the power cord is firmly connected to the dryer's wire harness.
- b) Access the electronic control board without disconnecting any wiring to the control board.

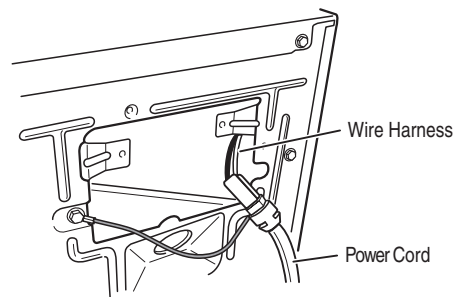

Power Cord-To-Wire Harness Connection For Gas Dryer

c) With an ohmmeter, check for continuity between the neutral (N) terminal of the plug and P1-2 (white wire) on the electronic control board.

- If there is continuity, go to step d.
- If there is no continuity, disconnect the white wire of the harness from the power cord at the location shown in step 3b. Test the continuity of the power cord neutral wire as shown below. If an open circuit is found, replace the power cord.
- Otherwise, proceed to step d.

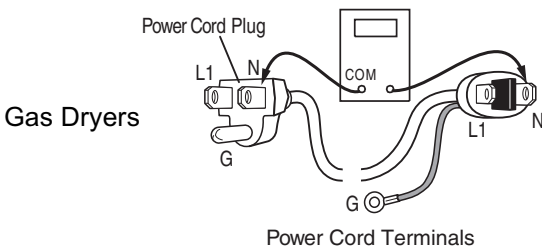

d) In a similar way, check the continuity between the L1 terminal of the plug and P1-5 (black wire) on the control board.

- If there is continuity, replace the control board.
- If there is no continuity, check the continuity of the power cord for the L1 wire.
- If an open circuit is found, replace the power cord.
- Otherwise, proceed to step e.

e) Replace the main wire harness.

4. Electric Dryers Only:

a) With an ohmmeter, check for continuity between the neutral (N) terminal of the plug and the center contact on the terminal block.

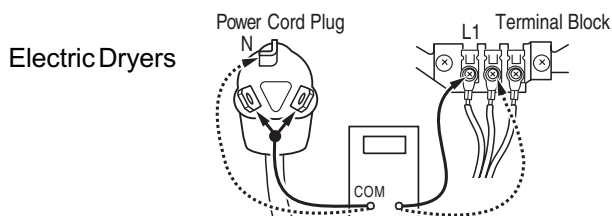

- If there is no continuity, replace the power cord and test the dryer.
- If there is continuity, go to step b.

b) In a similar way, check which terminal of the plug is connected to the left-most contact on the terminal block, and make a note of it. This will be L1 (black wire) in the wiring diagram.

- When this is found, go to step c.
- If neither of the plug terminals have continuity with the left-most contact of the terminal block, replace the power cord, and test the dryer.

c) Access the electronic control board without disconnecting any wiring to the control board.

d) With an ohmmeter, check for continuity between the L1 terminal of the plug and P1-5 (black wire) on the electronic control board.

- If there is continuity, go to step e.
- If there is no continuity, check that wires to the terminal block are mechanically secure. If so, replace the main wire harness, and test the dryer.

e) Check for continuity between the neutral (N) terminal of the plug and P1-2 (white wire) at the control board.

- If there is continuity, go to step f.
- If there is no continuity and the mechanical connections of the wire are secure, replace the main wire harness.

f) If the dryer still does not operate, replace the electronic control board.

TEST #2: MOTOR CIRCUIT TEST

This test will check the wiring to the motor and the motor itself. The following items are part of this system:

- Harness/connection
- Thermal fuse (electric dryers only)
- Belt/belt switch
- Drive motor
- Door switch
- Electronic control board

1. Unplug dryer or disconnect power.
2. Access the electronic control board and measure the resistance across P1-3 and P1-4.
 - If resistance across P1-3 and P1-4 is in the range of 1 to 6 ohms, replace the electronic control board.
 - Otherwise, go to step 3.
3. Check the wiring and components in the path between these measurement points (refer to the Wiring Diagrams in Section 7).
4. **Electric Dryers Only:** Check the thermal fuse (see TEST #3b on page 6-9).
5. Check the belt switch and drive motor.

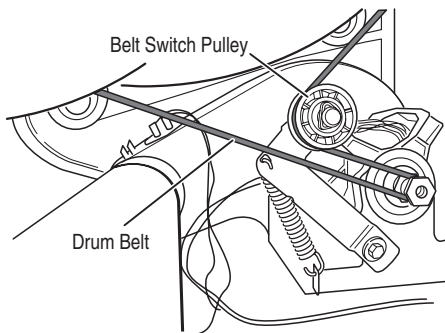

6. Remove the white connector from the drive motor switch.

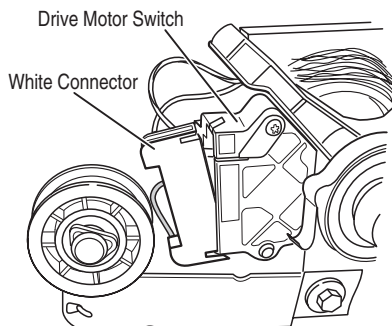

7. Check for the resistance values of the motor's Main and Start winding coils, as shown in the following table. **NOTE:** Main and Start winding coils must be checked at the motor.

Winding	Resistance	Test Points
MAIN	2.4 - 3.6 Ω	Blue wire in back & white/orange wire
START	2.4 - 3.8 Ω	Blue wire in back & violet wire

Main Winding: Blue Wire In Back And White/Orange Wire

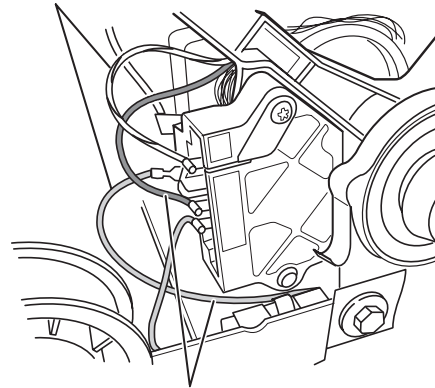

Start Winding: Blue Wire In Back And Violet Wire

- If the resistance at the motor is correct, there is an open circuit between the motor and electronic control board. Check for a failed belt switch.
8. Check the belt switch by measuring resistance between the two blue wires, while pushing up on the belt switch pulley.

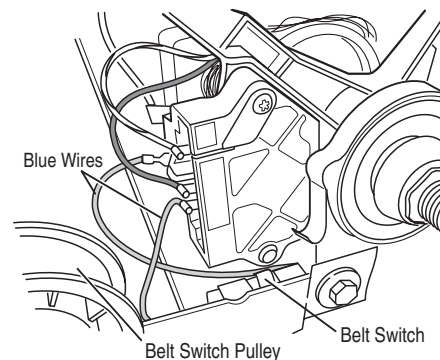

- If the resistance reading goes from infinity to a few ohms as pulley arm closes the switch, belt switch is okay. If not, replace the belt switch.

- If belt switch is okay and there is still an open circuit, check and repair the wiring harness.
 - If the Start winding is in question and the resistance is much greater than 4 ohms, replace the motor.
9. Door switch problems can be found using the Diagnostic Tests on page 6-2; however, if this was not done, the following (step 10) can be done without applying power to the dryer.
 10. Connect the ohmmeter test leads to the electronic control board at P1-2, (neutral, white wire), and P1-3 (door, blue wire). With the door closed, the ohmmeter should indicate a closed circuit (0 to 2 Ω). If not, replace the door switch assembly.

TEST #3: HEATER TEST

This test is performed when either of the following situations occur:

- Dryer does not heat
- Heat will not shut off

This test checks the components making up the heating circuit. The following items are part of this system:

- Harness/connection
- Heater relay
- Thermal fuse (gas dryer only)
- Thermal cutoff (electric dryer only)
- High-limit thermostat
- Gas burner assembly (gas dryer only)
- Heat element assembly (electric dryer only)
- Centrifugal switch
- Thermistor
- Electronic control board
- Console electronics & housing
- Gas supply (gas dryer only)

Dryer does not heat:

1. Unplug dryer or disconnect power.
2. Remove the toe panel to access the thermal components.

3. Gas Dryers Only:

- a) Perform TEST #3b (Thermal Fuse Test). If the thermal fuse is okay, proceed to step b.
- b) Connect the ohmmeter test leads to the red wire and the blue wire of the high-limit thermostat.
 - If there is an open circuit, replace the high-limit thermostat.
 - Otherwise, proceed to step c.
- c) Perform TEST #3c (Gas Valve Test). If this is okay, replace the electronic control board.

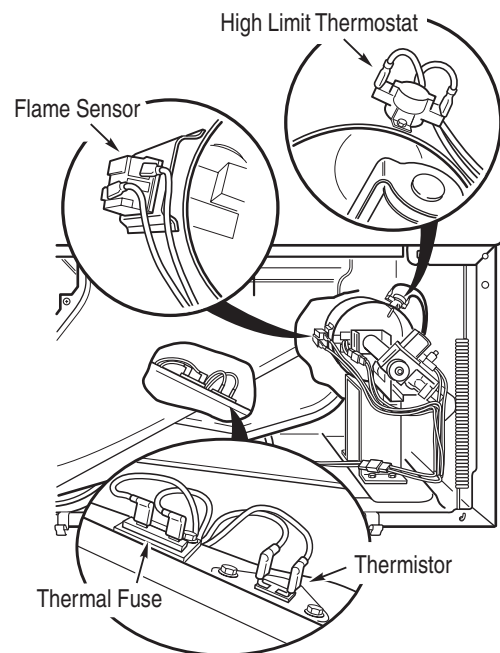

Continued on the next page.

4. Electric Dryers Only:

- a) Connect the ohmmeter test probes to the red wires at the thermal cutoff and the heater.
- If the resistance is approximately $10\ \Omega$, proceed to step c.
 - If an open circuit is detected, go to step b.
- b) Visually check the wire connections to the thermal cutoff, the high-limit thermostat, and the heater. If okay, check for continuity ($0\ \Omega$), across each of the components. Replace the one that is electrically open.

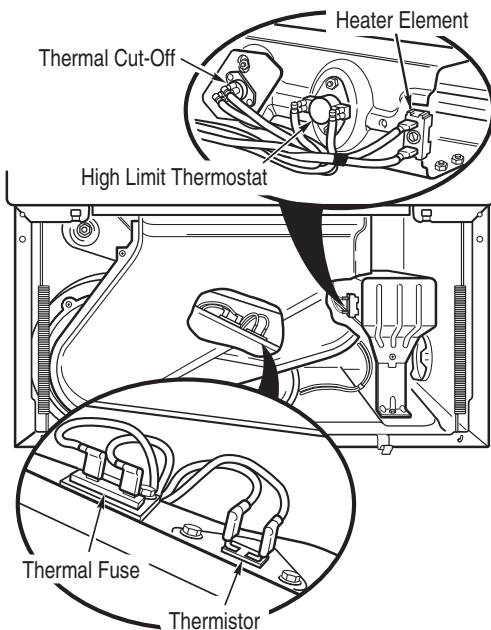

- c) If no open circuit is detected, measure the resistance between P2-5 (red/white wire) and P2-6 (black wire) at the electronic control board.
- If 6 to 7 $k\Omega$ are measured, replace the electronic control board.
 - If the resistance is less than 1 $k\Omega$, replace the thermistor.

Heat will not shut off:

1. Unplug dryer or disconnect power.
2. Use an ohmmeter, and touch the test leads to electronic control board points P2-5 (red/white wire) and P2-6 (black wire).
 - If 6 to 7 $k\Omega$ are measured, replace the electronic control board.
 - If the resistance is much greater than 7 $k\Omega$, replace the thermistor.

TEST #3a: THERMISTOR TEST

The electronic control board monitors the exhaust temperature using the thermistor, and cycles the heater relay on and off to maintain the desired temperature. Begin with an empty dryer and a clean lint screen.

1. Plug in dryer or reconnect power.
2. Set the dryer for the following configuration:
 - Door firmly closed.
 - Press CONTROL ON.
 - Press CYCLE END SIGNAL (Loud).
 - Press HOLD TO START.
3. If after 60 seconds, E1 or E2 flashes in the display and the dryer shuts off, the thermistor or wire harness is either shorted or open.
 - Unplug dryer or disconnect power.
 - Check the wire connections at the electronic control board and thermistor.
 - If the wire connections are good, remove the two wires from the thermistor, and replace the thermistor.
 - Plug in dryer or reconnect power.

4. If E1 or E2 does not flash in the display, the connections to the thermistor are good. Therefore, check the thermistor's resistance value at any or all of the temperature levels in question, using the Timed Dry Cycle, and the following process:

Hold a glass bulb thermometer capable of reading from 32° to 82°C (90° to 180°F) in the center of the exhaust outlet. The following table shows the correct exhaust temperatures.

Temperature Setting	Exhaust Temperatures	
	Heat Turns Off	Heat Turns On
High	68° ±6°C (155° ±10°F)	6 - 8°C (10 - 15°F) below the heat turn-off temperature
Medium	60° ±6°C (140° ±10°F)	
Low	52° ±6°C (125° ±10°F)	
Extra Low	41° ±3°C (105° ±5°F)	

5. If the exhaust temperature is not within specified limits, use the following table, and check the resistance of the thermistor.

TEMP. SETTING	TEMPERATURE	Thermistor resistance value at heater shutoff (digital or analog meter) kΩ	
High	155° ± 10°F (68° ± 6°C)	2.5	1.5
Medium	140° ± 10°F (60° ± 6°C)	4.0	3.0
Low	125° ± 10°F (52° ± 6°C)	5	4.3
Extra Low	105° ± 5°F (41° ± 3°C)	6	5

NOTE: All thermistor resistance measurements must be made while dryer is unplugged or disconnected from power.

The table shown above gives the resistance values that should be observed for the various temperature settings. If needed, use table at the top of the right column to find the temperatures and their associated resistance values.

- If the thermistor resistance checks within normal limits, replace the electronic control board.

THERMISTOR RESISTANCE			
TEMP. °C (°F)	RES. k Ω	TEMP. °C (°F)	RES. k Ω
10° (50°)	19.9	27° (80°)	9.2
16° (60°)	15.3	32° (90°)	7.4
21° (70°)	11.9	38° (100°)	5.7

TEST #3b: THERMAL FUSE TEST

1. Unplug dryer or disconnect power.
2. Access the thermal fuse by first removing the toe panel.
 - **Gas Dryers Only:** The thermal fuse is wired in series with the dryer gas valve. If the thermal fuse is open, replace it.
 - **Electric Dryers Only:** The thermal fuse is wired in series with the dryer drive motor. If the thermal fuse is open, replace it.

TEST #3c: GAS VALVE TEST (GAS DRYERS ONLY)

1. Unplug dryer or disconnect power.
2. Access the gas valve by first removing the toe panel.
3. Use an ohmmeter to determine if a gas valve coil has failed. Remove harness plugs. Measure resistance across terminals. Readings should match those shown in the chart below. If the readings are not as listed, replace the gas valve coil.

IMPORTANT: Be sure all harness wires are looped back through the strain relief after checking or replacing coils.

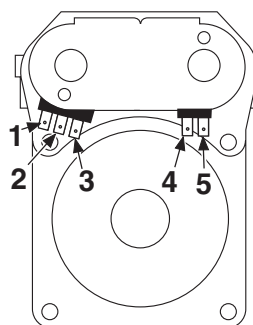

Terminals	Resistance
1 to 2	1365 Ω ±25
1 to 3	560 Ω ±25
4 to 5	1220 Ω ±50

TEST #3c: THERMAL CUTOFF TEST (ELECTRIC DRYERS ONLY)

If the dryer does not produce heat, check the status of the thermal cutoff.

1. Unplug dryer or disconnect power.
2. Access the thermal cutoff by first removing the toe panel.
3. Use an ohmmeter and check the continuity across the thermal cutoff.
 - If the ohmmeter indicates an open circuit, replace the failed thermal cutoff and high-limit thermostat. In addition, check for failed heat element, or blocked or improper exhaust system.

TEST #4: MOISTURE SENSOR TEST

NOTE: This test is performed when an automatic cycle stops too soon, or runs much longer than expected. The test is started with the dryer completely assembled. The dryer will shut down automatically after 2-1/2 hours.

The following items are part of the moisture sensor system:

- Harness/connection
- Metal sensor strips
- Electronic control board

1. Enter the Diagnostic Test mode.
2. Open the dryer door. If a beep tone is heard, and a software revision number is displayed on the console as soon as the door is opened, a short circuit exists in the moisture sensor system.
 - If this does not occur, proceed to step 3.
 - Otherwise, go to step 4

NOTE: Overdrying may be caused by a short circuit in the sensor system.

3. Bridge the two metal sensor strips on the face of the lint screen housing with a wet cloth or your finger.
 - If a beep is heard and a software revision number is displayed on the console, the sensor has passed the test. Proceed to step 4.
 - If the test is not successful, unplug the dryer or disconnect power.

- Access the moisture sensor and disconnect the sensor wires from the harness (see the illustration below). Proceed to step 8.

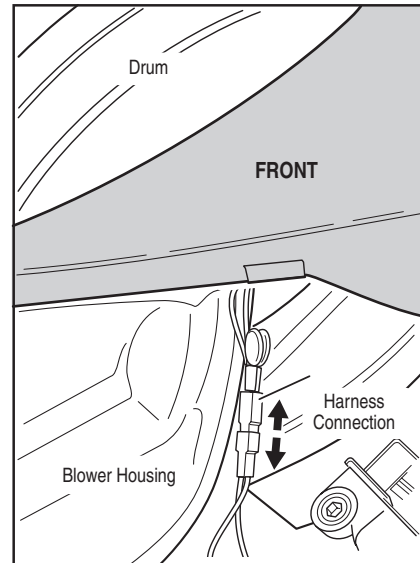

4. Unplug dryer or disconnect power.
5. Access the electronic control board and remove the P2 connector from the board. Use an ohmmeter and touch the test leads to connector terminals 1 (yellow/red wire) and 2 (black wire).
 - If the meter does not indicate an open circuit (infinite), go to step 6.
 - Otherwise, measure the resistance at pins 1 and 2 of connector P2 on the electronic control board. If a resistance less than 1 M Ω is measured, inspect the control board for any debris bridging the pins. If no debris is present, replace the board.
6. Access the moisture sensor by removing the toe panel. Disconnect the moisture sensor from the wire harness.
7. Measure the resistance across the outermost contacts of the cable that includes the two red discs (MOVs).
 - If a small resistance is measured, replace the wire harness and moisture sensor.
 - Otherwise, go to step 8.

8. Measure the resistance across the pins of the mating connector. If a small resistance is measured, replace this harness.
9. Measure the resistance across each of the outermost contacts and the center pin (ground).
 - If a resistance less than infinity is measured, replace the wire harness and moisture sensor.
10. If moisture sensor diagnostic test passes, check the thermistor (perform Test #3a, page 6-8).
 - If the problem persists after replacing the moisture sensor and thermistor, replace the electronic control board.

TEST #5: BUTTON & LED TEST

Activate the Diagnostic Test mode, and check for the following situations:

- None of the LEDs light up.
- A particular group of LEDs does not light up.
- A single LED does not light up.
- No beep sound is heard.
- No dryer function is activated when a particular button is pressed.
- E3 error code is displayed.

None of the LEDs light up:

1. See “Diagnostic Guide” on page 6-1 before servicing.
2. Visually check that connectors P3 and P4 are inserted all the way into the electronic control board. If these connections are good, perform the checks described in “Checking The Button Functions,” and “Checking The Rotary Cycle Selector.”
 - If this visual test passes, replace the electronic control board.
 - Otherwise, replace the console electronics and housing.

A particular group of LEDs does not light up:

A group or combination of LEDs share a common electronic connection. If this connection is open, all of the LEDs in the group will be disabled. Replace the console electronics and housing.

A single LED does not light up:

Press the button or manipulate the dial associated with the LED several times. If the LED does not light up, the LED has failed. Replace the console electronics and housing.

No beep sound is heard:

If the associated LEDs do light up, it is possible that the beeper circuit has failed. Check functions of buttons before replacing the electronic control board.

No dryer function is activated when a particular button is pressed:

If the associated LEDs do light up, it is possible that the electronic control board has failed. Check functions of buttons before replacing the electronic control board.

E3 error code is displayed:

If the E3 error code is displayed, there is a user interface or software mismatch. It is also possible that a component on the console electronics or the electronic control board has failed. Check functions of buttons before replacing the electronic control board. See “Checking The Button Functions” on page 6-12.

Checking The Button Functions

Before replacing the electronic control board, check for proper button function as follows:

- Unplug dryer or disconnect power.
- Disconnect the ribbon cables at P3 and P4 on the electronic control board. The illustration below shows the connector locations.

Using an ohmmeter, touch the meter test leads to the ribbon cable connector pin locations indicated in the table. Press the associated button and measure resistance.

NOTE: The meter must be connected with the proper polarity. For most analog meters, the connection polarity is opposite that of digital meters.

- **If using a digital meter**, the resistance reading should go from infinity down to approximately 1 to 3.5 M Ω (megohms). If available, you can use the “diode test” function on the digital meter.
- **If using an analog meter**, the resistance reading should go from infinity (open circuit) to less than 40 k Ω . If not, reverse the polarity of the meter connection, and measure the resistance again. If the reading is less than 40 k Ω , the circuit is okay, and you should continue the remainder of the resistance checks with the connections reversed from that indicated in the table.

Button	Digital Meter		Analog Meter	
	+ Lead	- Lead	- Lead	+ Lead
TEMP	P3-12	P3-8	P3-12	P3-8
EXTRA CARE	P3-13	P3-8	P3-13	P3-8
DRYNESS LEVEL	P3-14	P3-7	P3-14	P3-7
+	P3-13	P3-7	P3-13	P3-7
-	P3-12	P3-7	P3-12	P3-7
CYCLE END SIGNAL	P3-12	P4-2	P3-12	P4-2
HOLD TO START	P3-14	P4-2	P3-14	P4-2
OFF/Pause	P3-13	P4-2	P3-13	P4-2
CONTROL ON	P3-12	P3-9	P3-12	P3-9

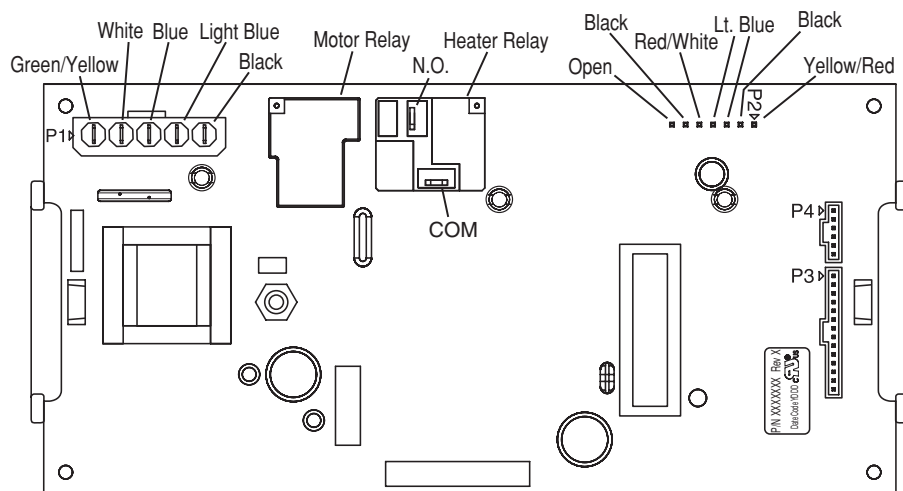

Checking The Rotary Cycle Selector

Using the following table, check the resistance at each cycle setting.

- When using a **digital** meter, touch the “+” ohmmeter test lead to P1-14, and leave it there during the tests. Touch the other test lead to the test points indicated in the chart.
- When using an **analog** meter, touch the “-” ohmmeter test lead to P1-14, and leave it there during the tests. Touch the other test lead to the test points indicated in the chart.

TEST #6: DOOR SWITCH TEST

Go into the Diagnostic Test mode on page 6-2. The door switch function is verified with a beep each time the door is opened and closed, and an alpha numeric code appears in the display (“0E”, “0g”, “1E”, or “2E”).

- If any of the conditions are not met, or if one of the dryer model codes listed above is displayed when the door is closed, check that the wires between the door switch and the electronic control board are properly connected.
- If the connections are okay, replace the door switch assembly and its wiring, and retest.
- If the door switch assembly and wiring have been replaced and dryer still does not start, replace the electronic control board.

Cycle Selection	Digital Meter + Lead On P1-14				Analog Meter – Lead On P1-14			
	P1-11	P1-10	P1-9	P1-8	P1-11	P1-10	P1-9	P1-8
Heavy Duty	•	•	•	•	•	•	•	•
Timed Dry	3.5 MΩ	•	3.5 MΩ	•	30 - 40 kΩ	•	10 - 20 kΩ	•
Touch Up	•	•	3.5 MΩ	•	•	•	10 - 20 kΩ	•
Rapid Dry	•	•	3.5 MΩ	1.59 MΩ	•	•	10 - 20 kΩ	10 - 20 kΩ
Super Delicate	•	1.58 MΩ	•	290 kΩ	•	10 - 20 kΩ	•	10 - 20 kΩ
Delicate	3.5 MΩ	290 kΩ	•	290 kΩ	10 - 20 kΩ	10 - 20 kΩ	•	10 - 20 kΩ
Casual	3.5 MΩ	•	•	290 kΩ	30 - 40 kΩ	•	•	10 - 20 kΩ
Normal	•	•	•	290 kΩ	•	•	•	10 - 20 kΩ

• = Infinite (∞)

— NOTES —

WIRING DIAGRAMS

ELECTRIC DRYER

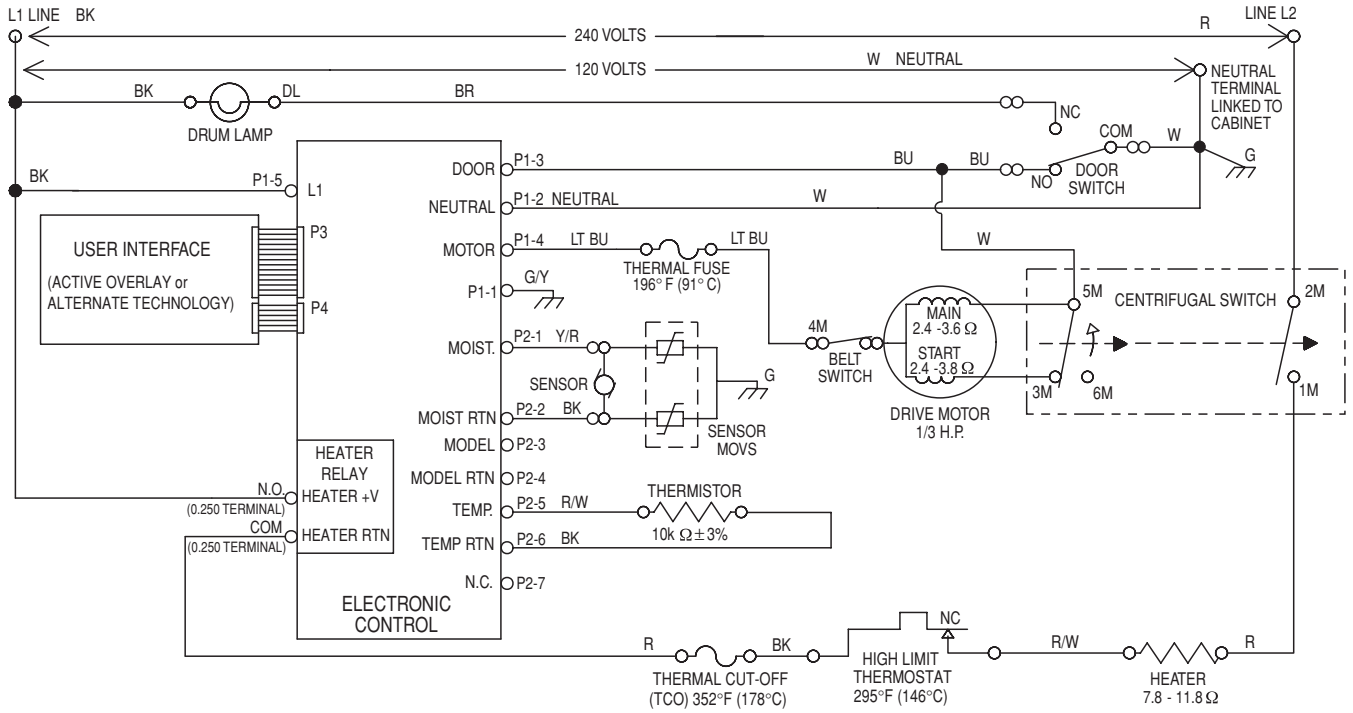

GAS DRYER

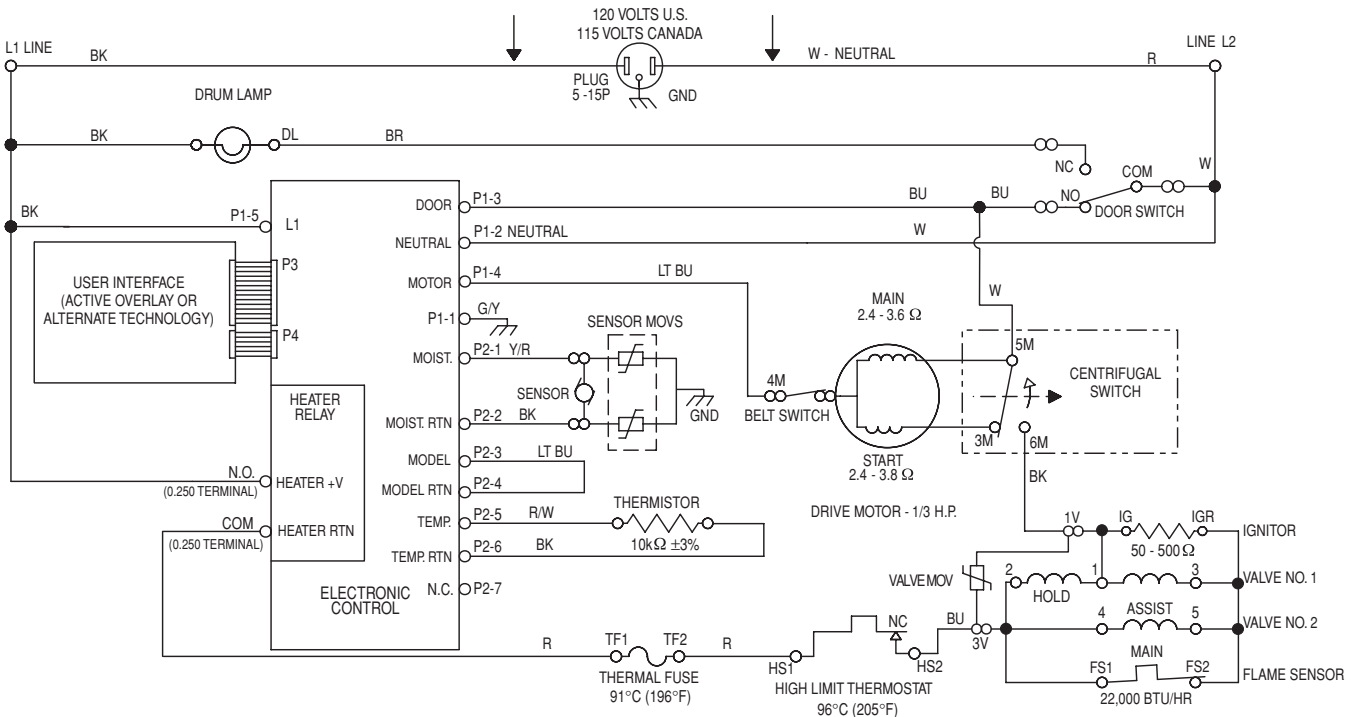

— NOTES —

PRODUCT SPECIFICATIONS AND WARRANTY INFORMATION SOURCES

IN THE UNITED STATES:

FOR PRODUCT SPECIFICATIONS AND WARRANTY INFORMATION CALL:

FOR WHIRLPOOL PRODUCTS: 1-800-253-1301
FOR KITCHENAID PRODUCTS: 1-800-422-1230
FOR ROPER PRODUCTS: 1-800-447-6737

FOR TECHNICAL ASSISTANCE WHILE AT THE CUSTOMER'S HOME CALL:

THE TECHNICAL ASSISTANCE LINE: 1-800-253-2870

**HAVE YOUR STORE NUMBER READY TO IDENTIFY YOU AS AN
AUTHORIZED SERVICER**

FOR LITERATURE ORDERS:

PHONE: 1-800-851-4605

FOR TECHNICAL INFORMATION AND SERVICE POINTERS:

www.servicematters.com

IN CANADA:

FOR PRODUCT SPECIFICATIONS AND WARRANTY INFORMATION CALL:

1-800-461-5681

FOR TECHNICAL ASSISTANCE WHILE AT THE CUSTOMER'S HOME CALL:

THE TECHNICAL ASSISTANCE LINE: 1-800-488-4791

**HAVE YOUR STORE NUMBER READY TO IDENTIFY YOU AS AN
AUTHORIZED SERVICER**

KitchenAid®
FOR THE WAY IT'S MADE.®

