



## **FORWARD**

This Whirlpool Job Aid “24” Electric Dryer” (Part No. 8178475), provides the technician with information on the installation, operation, and service of the 24” Electric Dryer. It is to be used as a training Job Aid and Service Manual. For specific information on the model being serviced, refer to the “Use and Care Guide,” or “Tech Sheet” provided with the dryer.

The Wiring Diagram used in this Job Aid is typical and should be used for training purposes only. Always use the Wiring Diagram supplied with the product when servicing the unit.

## **GOALS AND OBJECTIVES**

The goal of this Job Aid is to provide detailed information that will enable the service technician to properly diagnose malfunctions and repair the 24” Electric Dryer.

The objectives of this Job Aid are to:

- Understand and follow proper safety precautions.
- Successfully troubleshoot and diagnose malfunctions.
- Successfully perform necessary repairs.
- Successfully return the dryer to its proper operational status.

WHIRLPOOL CORPORATION assumes no responsibility for any repairs made on our products by anyone other than Authorized Service Technicians.

# TABLE OF CONTENTS

	Page
<b>GENERAL</b> .....	1-1
Safety First.....	1-1
Model & Serial Number Label Location .....	1-2
Whirlpool Dryer Warranty .....	1-3
<b>INSTALLATION INFORMATION</b> .....	2-1
Installation Instructions .....	2-1
<b>PRODUCT OPERATION</b> .....	3-1
Theory Of Operation .....	3-1
Dryer Use.....	3-3
<b>COMPONENT ACCESS</b> .....	4-1
Component Locations .....	4-1
Removing The Control Switches & Indicator Light .....	4-2
Removing The Door Switch .....	4-4
Removing The Safety Thermostats & The Dual Heating Elements .....	4-5
Removing The Belt And The Drum .....	4-6
Removing The Operating & Safety Thermostats .....	4-8
Removing The Front Slide Blocks & Rear Seal .....	4-9
Removing The Main And Fan Motors & Capacitors .....	4-10
<b>COMPONENT TESTING</b> .....	5-1
Pushbutton Switches .....	5-1
Door Switch .....	5-2
Dual Heating Elements .....	5-2
Thermostats .....	5-3
Main & Fan Motor Capacitors .....	5-3
Main Motor .....	5-4
Fan Motor .....	5-4
<b>WIRING DIAGRAM</b> .....	6-1

— NOTES —



# GENERAL SAFETY FIRST

**Your safety and the safety of others is very important.**

We have provided many important safety messages in this Job Aid and on the appliance. Always read and obey all safety messages.



This is the safety alert symbol.

This symbol alerts you to hazards that can kill or hurt you and others.

All safety messages will follow the safety alert symbol and either the word “DANGER” or “WARNING.” These words mean:

**! DANGER**

**You can be killed or seriously injured if you don't immediately follow instructions.**

**! WARNING**

**You can be killed or seriously injured if you don't follow instructions.**

All safety messages will tell you what the potential hazard is, tell you how to reduce the chance of injury, and tell you what can happen if the instructions are not followed.

# MODEL & SERIAL NUMBER LABEL LOCATION

The Model/Serial Number label location is shown below.

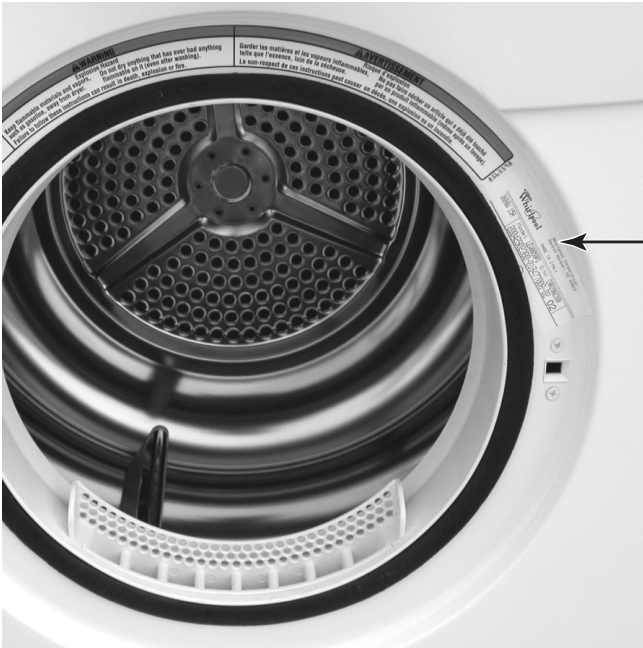

**Model & Serial Number Label Location**

# WHIRLPOOL DRYER WARRANTY

## ONE-YEAR FULL WARRANTY

For one year from the date of purchase, when this dryer is operated and maintained according to instructions attached to or furnished with the product, Whirlpool Corporation will pay for FSP® replacement parts and repair labor costs to correct defects in materials or workmanship. Service must be provided by a Whirlpool designated service company.

---

### **Whirlpool Corporation will not pay for:**

1. Service calls to correct the installation of your dryer, including venting. Heavy 4" (10.2 cm) metal exhaust vent must be used. Refer to the venting section of this manual and your Installation Instructions.
  2. Service calls to instruct you how to use your dryer, to replace house fuses or correct house wiring or reset circuit breakers, or to replace owner accessible light bulbs.
  3. Repairs when your dryer is used in other than normal, single-family household use.
  4. Damage resulting from accident, alteration, misuse, abuse, fire, floods, acts of God, improper installation (including, but not limited to, venting with plastic or flexible foil), installation not in accordance with local electrical and plumbing codes, or use of products not approved by Whirlpool Corporation.
  5. Replacement parts or repair labor costs for units operated outside the United States.
  6. Pickup and delivery. This product is designed to be repaired in the home.
  7. Repairs to parts or systems resulting from unauthorized modifications made to the appliance.
- 

### **WHIRLPOOL CORPORATION SHALL NOT BE LIABLE FOR INCIDENTAL OR CONSEQUENTIAL DAMAGES.**

Some states do not allow the exclusion or limitation of incidental or consequential damages, so this exclusion or limitation may not apply to you. This warranty gives you specific legal rights and you may also have other rights which vary from state to state.

**Outside the 50 United States, this warranty does not apply. Contact your authorized Whirlpool dealer to determine if another warranty applies.**

If you need service, first see "Troubleshooting" in the "Use and Care Guide." Additional help can be found by checking "Assistance or Service," or by calling our Customer Interaction Center at **1-800-253-1301**, from anywhere in the U.S.A., or write: Whirlpool Corporation, Customer Interaction Center, 553 Benson Road, Benton Harbor, MI 49022-2692.

— NOTES —

# INSTALLATION INFORMATION

## INSTALLATION INSTRUCTIONS

### TOOLS AND PARTS

#### Tools Needed

Gather the required tools and parts before starting installation. Read and follow the safety instructions provided with any tools listed here.

Flat-blade screwdriver

Level

Adjustable wrench

T20 Torx Screwdriver

Wire stripper (direct wire installations)

Wood block

Caulking gun and compound (for installing new exhaust vent)

Tin snips (new vent installations)

Vent clamps

#### Parts Supplied

Remove parts package from the dryer drum. Check that all parts listed are included.

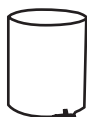

Coupling

#### Parts Needed

Check local codes, existing electrical supply and venting, and see “Venting Requirements” and “Electrical Requirements” before purchasing parts.

### LOCATION REQUIREMENTS

#### **WARNING**



#### **Explosion Hazard**

**Keep flammable materials and vapors, such as gasoline, away from dryer.**

**Place dryer at least 18 inches (46 cm) above the floor for a garage installation.**

**Failure to do so can result in death, explosion, or fire.**

#### You Will Need

- A location that allows for proper exhaust installation (see “Venting Requirements”).
- A separate 30 amp circuit.
- A grounded electrical outlet located within 2 ft (61 cm) of either side of the dryer (see “Electrical Requirements”).
- A sturdy floor to support the dryer weight (dryer and load) of 115 lbs (52 kg). The combined weight of a companion appliance should also be considered.
- A level floor with a maximum slope of 1” (2.5 cm) under entire dryer.

Do not operate your dryer at temperatures below 45°F (7°C). At lower temperatures, the dryer might not shut off at the end of an automatic cycle. Drying times can be extended.

The dryer must not be installed or stored in an area where it will be exposed to water and/or weather.

Check code requirements. Some codes limit, or do not permit, installation of the dryer in garages, closets, mobile homes, or sleeping quarters. Contact your local building inspector.

## Installation Clearances

The location must be large enough to allow the dryer door to open fully.

## Dryer Dimensions

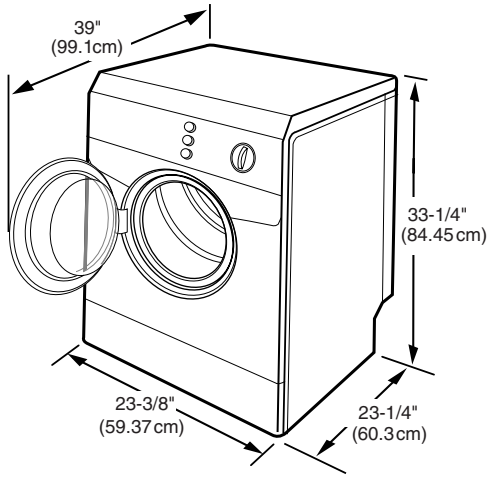

Most installations require a minimum 5-1/2" (14.0 cm) clearance behind the dryer for the exhaust vent with elbows (see "Venting Requirements").

## Minimum Installation Spacing For Recessed Area And Closet Installation

The following dimensions shown are for the minimum spacing allowed when the unit is to be operated with, or without, the Stack Stand Kit. To purchase a Stack Stand Kit, see "Assistance or Service" in the "Use And Care Guide."

- Additional spacing should be considered for ease of installation and servicing.
- Additional clearances might be required for wall, door, and floor moldings.
- Additional spacing of 1" (2.5 cm) on all sides of the dryer is recommended to reduce noise transfer.
- For closet installation with a door, minimum ventilation openings in the top and bottom of the door are required. Louvered doors with equivalent ventilation openings are acceptable.
- Companion appliance spacing should also be considered.

## Recessed Or Closet Installation—Dryer Only

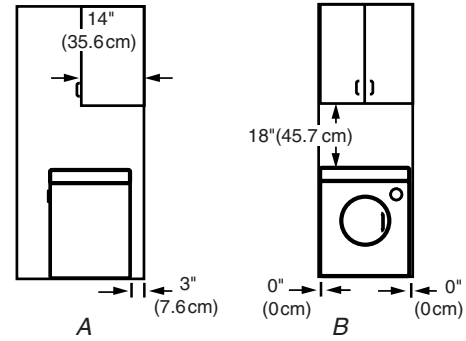

A. Side view - closet or confined area  
B. Recessed area

## Recessed Or Closet Installation—Stacked

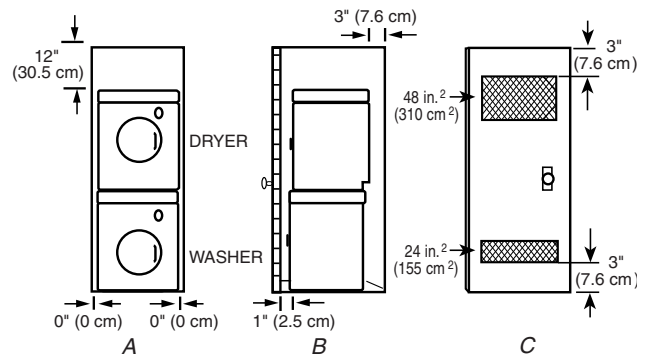

A. Recessed area  
B. Side view - closet or confined area  
C. Closet door with vents

## Mobile Home—Additional Location Requirements

This dryer is suitable for mobile home installations. The installation must conform to the Manufactured Home Construction and Safety Standard, Title 24 CFR, Part 3280 (formerly the Federal Standard for Mobile Home Construction and Safety, Title 245, HUD Part 280).

### Mobile Home Installations Require

- Metal exhaust system hardware which is available for purchase from your dealer.
- Special provisions must be made in mobile homes to introduce outside air into the dryer. The opening (such as a nearby window) should be at least twice as large as the dryer exhaust opening.

## ELECTRICAL REQUIREMENTS

### It is your responsibility

- To contact a qualified electrical installer.
- To be sure that the electrical connection is adequate and in conformance with the National Electrical Code, ANSI/NFPA 70-latest edition and all local codes and ordinances.

The National Electric Code requires a 4-wire supply connection for homes built after 1996, dryer circuits involved in remodeling after 1996, and all mobile home installations.

A copy of the above code standards can be obtained from: National Fire Protection Association, One Batterymarch Park, Quincy, MA 02269.

- To supply the required 3 or 4 wire, single phase, 120/240-volt, 60-Hz., AC-only electrical supply (or 3 or 4 wire, 120/208-volt electrical supply, if specified on the serial/rating plate) on a separate 30-amp circuit, fused on both sides of the line. A time-delay fuse or circuit breaker is recommended. Connect to an individual branch circuit. Do not have a fuse in the neutral or grounding circuit.
- Do not use an extension cord.
- If codes permit and a separate ground wire is used, it is recommended that a qualified electrician determine that the ground path is adequate.

### Electrical Connection

To properly install your dryer, you must determine the type of electrical connection you will be using and follow the instructions provided for it here.

- This dryer is manufactured ready to install with a 3-wire electrical supply connection. The green cabinet-grounding conductor is permanently connected to the neutral conductor (white wire) within the dryer. If the dryer is installed with a 4-wire electrical supply connection, the green cabinet-grounding conductor must be removed from the external ground conductor screw (green screw), and secured under the neutral terminal (center or white wire) of the terminal block. When the green cabinet-grounding conductor is secured under the neutral terminal (center or white wire) of the terminal block, the dryer cabinet is isolated from the neutral conductor.
- Use a 4-wire conductor cord when the dryer is installed in a mobile home or an area where local codes do not permit grounding through the neutral.

### If using a power supply cord:

Use a UL listed power supply cord kit marked for use with clothes dryers. The kit should contain:

- A UL listed 30 amp power supply cord, rated 120/240-volt minimum. The cord should be type SRD or SRDT and be at least 4 ft (1.22m) long. The wires that connect to the dryer must end in ring terminals or spade terminals with upturned ends.
- A UL listed strain relief.

### If your outlet looks like this:



4-Wire Receptacle (14-30R)

Then choose a 4-wire power supply cord with ring or spade terminals and UL listed strain relief. The 4-wire power supply cord, at least 4 ft (1.22 m) long, must have 4, 10-gauge copper wires and match a 4-wire receptacle of NEMA Type 14-30R. The ground wire (ground conductor) may be either green or bare. The neutral conductor must be identified by a white cover.

### If your outlet looks like this:



3-Wire Receptacle (10-30R)

Then choose a 3-wire power supply cord with ring or spade terminals and UL listed strain relief. The 3-wire power supply cord, at least 4 ft (1.22 m) long, must have 3, 10-gauge copper wires and match a 3-wire receptacle of NEMA Type 10-30R.

### If connecting by direct wire:

Power supply cable must match power supply (4-wire or 3-wire) and be:

- Flexible armored cable or nonmetallic sheathed copper cable (with ground wire), protected with flexible metallic conduit. All current-carrying wires must be insulated.
- 10-gauge solid copper wire (do not use aluminum).
- At least 5 ft (1.52 m) long.

### GROUNDING INSTRUCTIONS

- For a grounded, cord-connected dryer:  
This dryer must be grounded. In the event of malfunction or breakdown, grounding will reduce the risk of electric shock by providing a path of least resistance for electric current. This dryer uses a cord having an equipment-grounding conductor and a grounding plug. The plug must be plugged into an appropriate outlet that is properly installed and grounded in accordance with all local codes and ordinances.

- For a permanently connected dryer:  
This dryer must be connected to a grounded metal, permanent wiring system, or an equipment-grounding conductor must be run with the circuit conductors and connected to the equipment-grounding terminal or lead on the dryer.

**WARNING:** Improper connection of the equipment-grounding conductor can result in a risk of electric shock. Check with a qualified electrician or service representative, or personnel if you are in doubt as to whether the dryer is properly grounded. Do not modify the plug on the power supply cord: if it will not fit the outlet, have a proper outlet installed by a qualified electrician.



# ELECTRICAL CONNECTION

## Power Supply Cord

**! WARNING**



### Fire Hazard

Use a new UL listed 30 amp power supply cord.

Use a UL listed strain relief.

Disconnect power before making electrical connections.

Connect neutral wire (white or center wire) to center terminal (silver).

Ground wire (green or bare wire) must be connected to green ground connector.

Connect remaining 2 supply wires to remaining 2 terminals (gold).

Securely tighten all electrical connections.

Failure to do so can result in death, fire, or electrical shock.

1. Disconnect power.
2. Remove the terminal block cover.

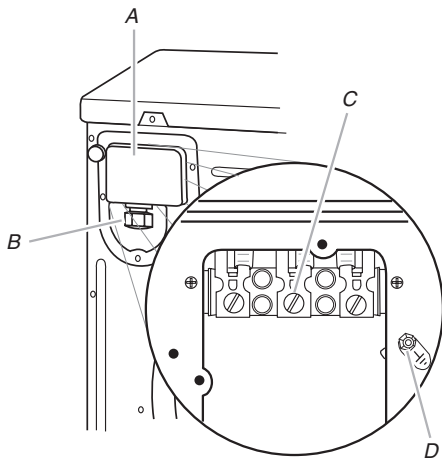

A. Terminal block cover  
B. Strain relief  
C. Center, terminal block screw  
D. External ground conductor screw

## Direct Wire

**! WARNING**



### Fire Hazard

Use 10 gauge solid copper wire.

Use a UL listed strain relief.

Disconnect power before making electrical connections.

Connect neutral wire (white or center wire) to center terminal (silver).

Ground wire (green or bare wire) must be connected to green ground connector.

Connect remaining 2 supply wires to remaining 2 terminals (gold).

Securely tighten all electrical connections.

Failure to do so can result in death, fire, or electrical shock.

3. Unscrew the strain relief from the terminal block cover.
4. Unscrew the strain relief nut from the strain relief.
5. Put the power supply cord through the strain relief nut, then the strain relief.

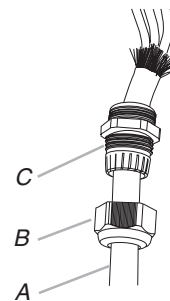

A. Power cord  
B. Strain relief nut  
C. UL listed Strain relief

- Replace strain relief (with power cord inserted) back into the terminal block cover. Do not tighten strain relief nut.

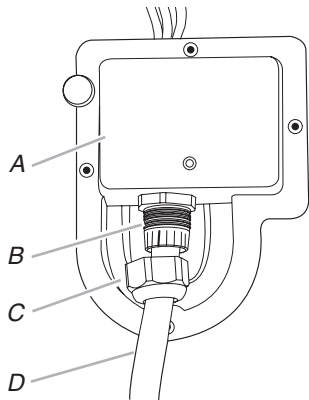



A. Terminal block cover  
 B. Strain relief  
 C. Strain relief nut  
 D. Power cord

- Now complete installation following instructions for your type of electrical connection:

4-wire (recommended)  
 3-wire (if 4-wire is not available)

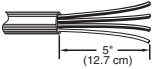
### Electrical Connection Options

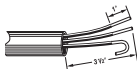
If your home has:	And you will be connecting to:	Go to section:
4-wire receptacle (NEMA type 14-30R) 	A UL listed, 120/240 volt minimum, 30 amp, dryer power supply cord	4-wire connection: Power supply cord
4-wire direct 	A fused disconnect or circuit breaker box	4-wire connection: Direct Wire
3-wire receptacle (NEMA type 10-30R) 	A UL listed, 120/240 volt minimum, 30 amp, dryer power supply cord	3-wire connection: Power supply cord
3-wire direct 	A fused disconnect or circuit breaker box	3-wire connection: Direct Wire

### 4-Wire Connection: Power Supply Cord

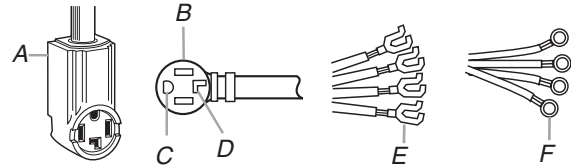

A. 4-wire receptacle (NEMA type 14-30R)  
 B. 4-prong plug  
 C. Ground prong  
 D. Neutral prong  
 E. Spade terminals with upturned ends  
 F. Ring terminals

- Locate the neutral grounding wire (green with yellow stripes) inside the dryer cabinet, behind the external ground conductor screw. Remove this wire.

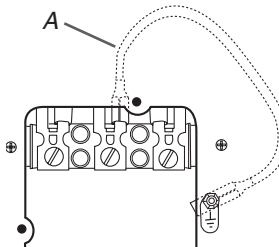

A. Remove neutral grounding wire (green with yellow stripes)

- Connect ground wire (green or bare) of power supply cord to external ground conductor screw. Tighten screw.
- Connect neutral wire (white or center wire) of power supply cord under center screw of the terminal block.

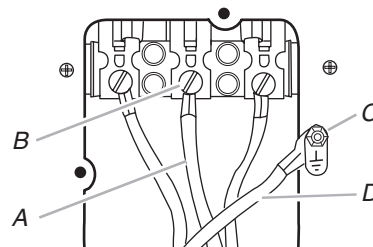

A. Neutral wire (white or center wire)  
 B. Center terminal block screw  
 C. External ground conductor screw  
 D. Ground wire (green or bare) of power supply cord

- Connect the other wires to outer terminal block screws. Tighten screws.
- Replace the terminal block cover on the back of the dryer.
- Tighten strain relief nut.

#### 4-Wire Connection: Direct Wire

Direct wire cable must have 5 ft (1.52 m) of extra length so dryer can be moved if needed.

Strip 5" (12.7 cm) of outer covering from end of cable, leaving bare ground wire at 5" (12.7 cm). Cut 1-1/2" (3.8 cm) from three remaining wires. Strip insulation back 1" (2.5 cm). Shape ends of wires into a hook shape.

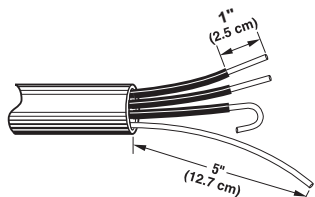

When connecting to the terminal block, place the hooked end of the wire under the screw of the terminal block (hook facing right), squeeze hooked end together and tighten screw.

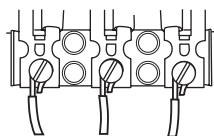

1. Locate the neutral grounding wire (green with yellow stripes) inside the dryer cabinet, behind the external ground conductor screw. Remove this wire.

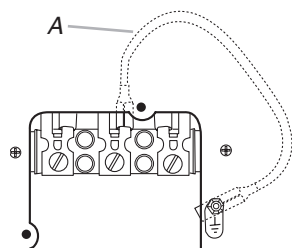

A. Remove neutral grounding wire (green with yellow stripes)

2. Loosen or remove center terminal block screw.
3. Connect ground wire (green or bare) of power supply cord to external ground conductor screw. (If power supply cord has ring terminals, the ground conductor screw will need to be removed to make the connection). Tighten screw.
4. Place the hooked end of the neutral wire (white or center wire) of power supply cable under the center screw of terminal block (hook facing right). Squeeze hooked end together. Tighten screw.

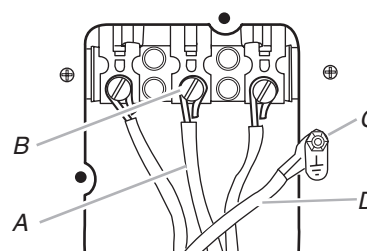

A. Neutral wire (white or center wire)  
B. Center terminal block screw  
C. External ground conductor screw  
D. Green or bare wire of power supply cable

5. Place the hooked ends of the other power supply cable wires under the outer terminal block screws (hooks facing right). Squeeze hooked ends together. Tighten screws.

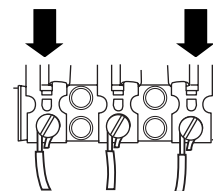

6. Replace the terminal block cover on the back of the dryer.
7. Tighten strain relief nut.

### 3-Wire Connection: Power Supply Cord

Use where local codes permit connecting cabinet-ground conductor to neutral wire.

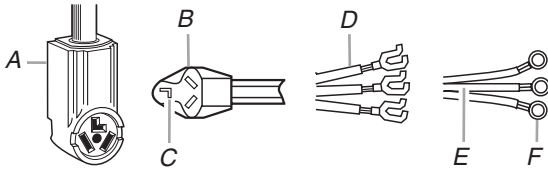

- A. 3-wire receptacle (NEMA type 10-30R)
- B. 3-wire plug
- C. Neutral prong
- D. Spade terminals with up turned ends
- E. Neutral (white or center wire)
- F. Ring terminals

1. Loosen or remove center terminal block screw.
2. Connect neutral wire (white or center wire) of power supply cord under center screw of the terminal block. Tighten screw.

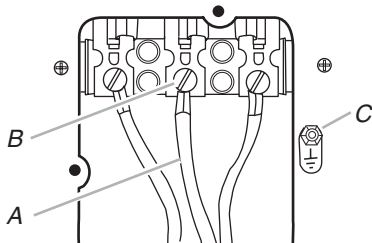

- A. Neutral wire (white or center wire)
- B. Center terminal block screw
- C. External ground conductor screw

3. Connect the other wires to outer terminal block screws. Tighten screws.
4. Replace the terminal block cover on the back of the dryer.
5. Tighten strain relief nut.

### 3-Wire Connection: Direct Wire

Use where local codes permit connecting cabinet-ground conductor to neutral wire.

Direct wire cable must have 5 ft (1.52 m) of extra length so dryer can be moved if needed.

Strip 3-1/2" (8.9 cm) of outer covering from end of cable. Strip insulation back 1" (2.5 cm). If using 3-wire cable with ground wire, cut bare wire even with outer covering. Shape ends of wires into a hook shape.

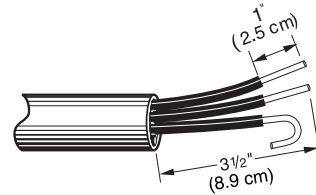

When connecting to the terminal block, place the hooked end of the wire under the screw of the terminal block (hook facing right), squeeze hooked end together and tighten screw.

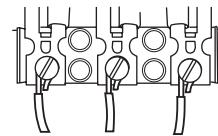

1. Loosen or remove center terminal block screw.
2. Place the hooked end of the neutral wire (white or center wire) of power supply cable under the center screw of terminal block (hook facing right). Squeeze hooked end together. Tighten screw.

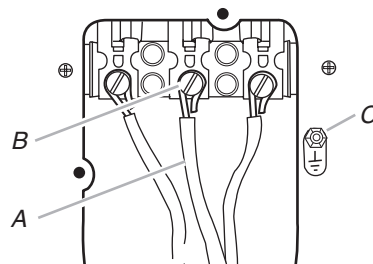

- A. Neutral wire (white or center wire)
- B. Center terminal block screw
- C. External ground conductor screw

3. Place the hooked ends of the other power supply cable wires under the outer terminal block screws (hooks facing right). Squeeze hooked ends together. Tighten screws.
4. Replace the terminal block cover on the back of the dryer.
5. Tighten strain relief nut.

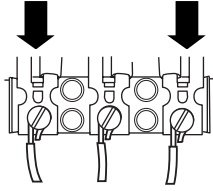

## VENTING REQUIREMENTS

**! WARNING**



**Fire Hazard**  
**Use a heavy metal vent.**  
**Do not use a plastic vent.**  
**Do not use a metal foil vent.**  
**Failure to follow these instructions can result in death or fire.**

**WARNING:** To reduce the risk of fire, this dryer **MUST BE EXHAUSTED OUTDOORS.**

4" (10.2 cm) heavy metal exhaust vent and clamps must be used. DURASAFE™ vent products are recommended.

DURASAFE™ vent products can be purchased from your dealer, or by calling Whirlpool Parts and Accessories.

- The dryer exhaust must not be connected into any gas vent, chimney, wall, ceiling, or a concealed space of a building.
- Do not use an exhaust hood with a magnetic latch.
- Do not install flexible metal vent in enclosed walls, ceilings or floors.
- Use clamps to seal all joints. Exhaust vent must not be connected or secured with screws or other fastening devices which extend into the interior of the duct. Do not use duct tape.

**IMPORTANT:** Observe all governing codes and ordinances.

**Improper venting can cause moisture and lint to collect indoors, which may result in:**

- Moisture damage to woodwork, furniture, paint, wallpaper, carpets, etc.
- Housecleaning problems and health problems.

Use a heavy metal vent. Do not use plastic or metal foil vent.

Rigid metal vent is recommended to prevent crushing and kinking.

Flexible metal vent must be fully extended and supported when the dryer is in its final position. Remove excess flexible metal vent to avoid sagging and kinking that may result in reduced airflow.

An exhaust hood should cap the vent to prevent rodents and insects from entering the home.

Exhaust hood must be at least 12" (30.5 cm) from the ground or any object that may be in the path of the exhaust (such as flowers, rocks or bushes, etc.).

If using an existing vent system, clean lint from the entire length of the system and make sure exhaust hood is not plugged with lint. Replace any plastic or metal foil vent with rigid metal or flexible metal vent.

## PLAN VENT SYSTEM

### Typical Exhaust Installations

Typical installations vent the dryer from the rear of the dryer.

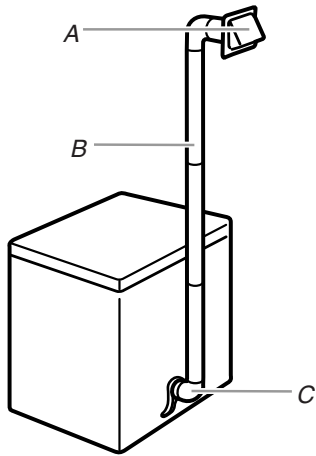

A. Exhaust hood  
B. Flexible metal vent or rigid metal vent  
C. Elbow

### Alternate Installation For Close Clearances

Venting systems come in many varieties. Select the type best for your installation. A close-clearance installation is shown below. Refer to the manufacturer's instructions provided with the vent system.

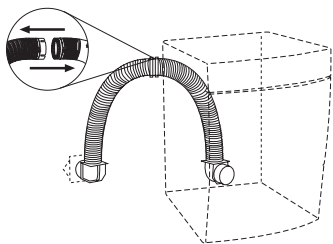

Over-The-Top installation  
(also available with one offset elbow)

Over-The-Top Installation Kit Part Number **4396028** for close clearance alternate installation is available for purchase. For ordering information see "Assistance or Service" in the "Use And Care Guide."

### Special Provisions For Mobile Home Installations

The exhaust vent must be securely fastened to a noncombustible portion of the mobile home structure and must not terminate beneath the mobile home. Terminate the exhaust vent outside.

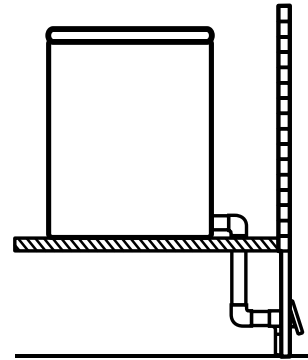

### Determine Vent Length

1. Select the route that will provide the straightest and most direct path outdoors. Plan the installation to use the fewest number of elbows and turns. When using elbows or making turns, allow as much room as possible. Bend vent gradually to avoid kinking. Avoid 90° turns when possible.

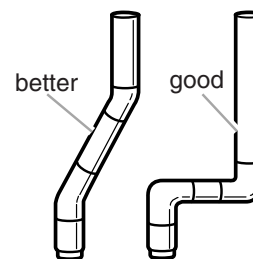

2. Determine vent length. The maximum length of the exhaust system depends upon:

- The type of vent (rigid metal or flexible metal).
- The number of elbows used.
- Type of hood.

Recommended hood styles are shown here.

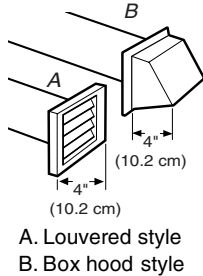

The angled hood style (shown following) is acceptable.

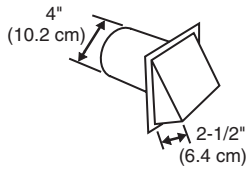

See the exhaust vent length chart that matches your hood type for the maximum vent lengths you can use.

Exhaust systems longer than specified will:

- Shorten the life of the dryer.
- Reduce performance, resulting in longer drying times and increased energy usage.

3. Determine the number of elbows you will need.

**IMPORTANT:** Do not use vent runs longer than specified in the Vent Length Chart.

In the column listing the type of metal vent you are using (rigid metal or flexible metal), find the maximum length of metal vent on the same line as the number of elbows.

## Vent Length Chart

Number of 90° turns or elbows	Type of vent	Box or louvered hoods	Angled hoods
0	Rigid metal	90 ft (27.4 m)	80 ft (24.4 m)
	Flexible metal	64 ft (19.5 m)	58 ft (17.7 m)
1	Rigid metal	80 ft (24.4 m)	70 ft (21.3 m)
	Flexible metal	58 ft (17.7 m)	52 ft (15.8 m)
2	Rigid metal	70 ft (21.3 m)	60 ft (18.3 m)
	Flexible metal	50 ft (15.2 m)	42 ft (12.8 m)

## INSTALL VENT SYSTEM

1. Install exhaust hood. Use caulking compound to seal exterior wall opening around exhaust hood.
2. Connect vent to exhaust hood. Vent must fit inside exhaust hood. Secure vent to exhaust hood with 4" (10.2 cm) clamp.
3. Run vent to dryer location. Use the straightest path possible (see "Determine Vent Length"). Avoid 90° turns. Use clamps to seal all joints. Do not use duct tape, screws or other fastening devices that extend into the interior of the vent to secure vent.

## LEVEL DRYER

Check the levelness of the dryer. Check levelness first side to side, then front to back.

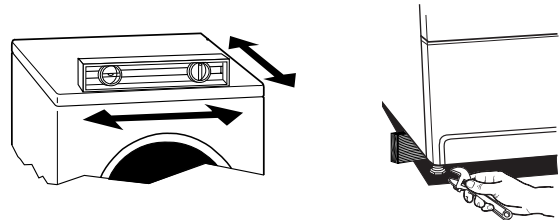

If the dryer is not level, prop up the dryer using a wood block. Use a wrench to adjust the legs up or down, and check the level again.

**NOTE:** It might be necessary to level the dryer again after it has been moved into its final position.



## CONNECT VENT

1. Using the coupling supplied with the dryer, connect the exhaust vent to the coupling and secure with a 4" (10.2 cm) vent clamp. See Illustration below.

If connecting to existing vent, make sure the vent is clean.

2. Turn the coupling (together with the exhaust vent) counterclockwise in the air discharge outlet on the back of the dryer.

The dryer exhaust vent must fit over the coupling and inside the exhaust hood.

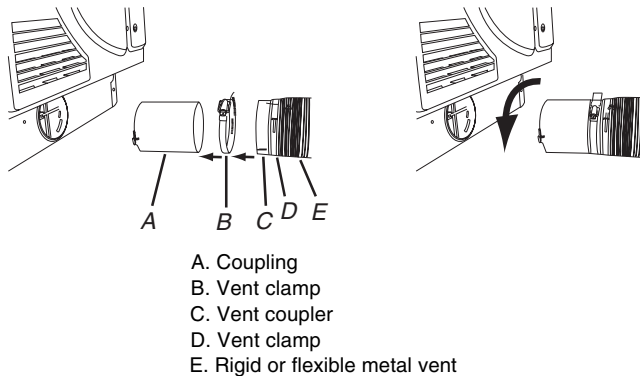

3. Make sure the exhaust vent is secured to exhaust hood with a 4" (10.2 cm) vent clamp.
4. Move dryer into final position. Do not crush or kink vent. Make sure dryer is level.

## COMPLETE THE INSTALLATION

1. Check to be sure all parts are now installed. If there is an extra part, go back through the steps to see which step was skipped.
2. Check to be sure you have all of your tools.
3. Dispose of/recycle all packaging materials.

4. Check the dryer's final location. Be sure the vent is not crushed or kinked.
5. Check to be sure the dryer is level. See "Level Dryer."
6. Plug into a grounded outlet. Turn power on.
7. Remove the clear protective film on the front edge and any tape remaining on the dryer.
8. Read "Dryer Use."
9. Wipe the dryer drum interior thoroughly with a damp cloth to remove any dust.
10. Set the dryer on a full heat cycle (not an air cycle) for 20 minutes and start the dryer.

### If the dryer will not start, check the following:

- Controls are set in a running or "On" position.
  - Start button has been pushed firmly.
  - Dryer is plugged into a grounded outlet.
  - Electrical supply is connected.
  - House fuse is intact and tight, or circuit breaker has not tripped.
  - Dryer door is closed.
11. When the dryer has been running for 5 minutes, open the dryer door and feel for heat.

### If you do not feel heat, turn the dryer off and check the following:

- There may be 2 fuses or circuit breakers for the dryer. Check to make sure both fuses are intact and tight, or that both circuit breakers have not tripped.

**NOTE:** You may notice a burning odor when the dryer is first heated. This odor is common when the heating element is first used. The odor will go away.

— NOTES —

# PRODUCT OPERATION

## THEORY OF OPERATION

### HEATER OPERATION

This dryer uses a dual element heater. Depending on the selected temperature, either one or both of the elements will be in the circuit during the drying mode.

In the Normal temperature setting, both elements are in the circuit. One element (R1) is controlled by the operating thermostat. As the thermostat cycles, the second element (R2) remains in the circuit, and maintains a consistent operating temperature.

In the Low temperature setting, a switch opens the circuit to R2, and it is removed, and drying takes place with the R1 element only.

### SAFETY THERMOSTATS

A pair of safety thermostats is located on the dual element housing. One is a manual reset thermostat, (302°F (150°C)), and the other is a self-resetting thermostat (194°F (90°C)).

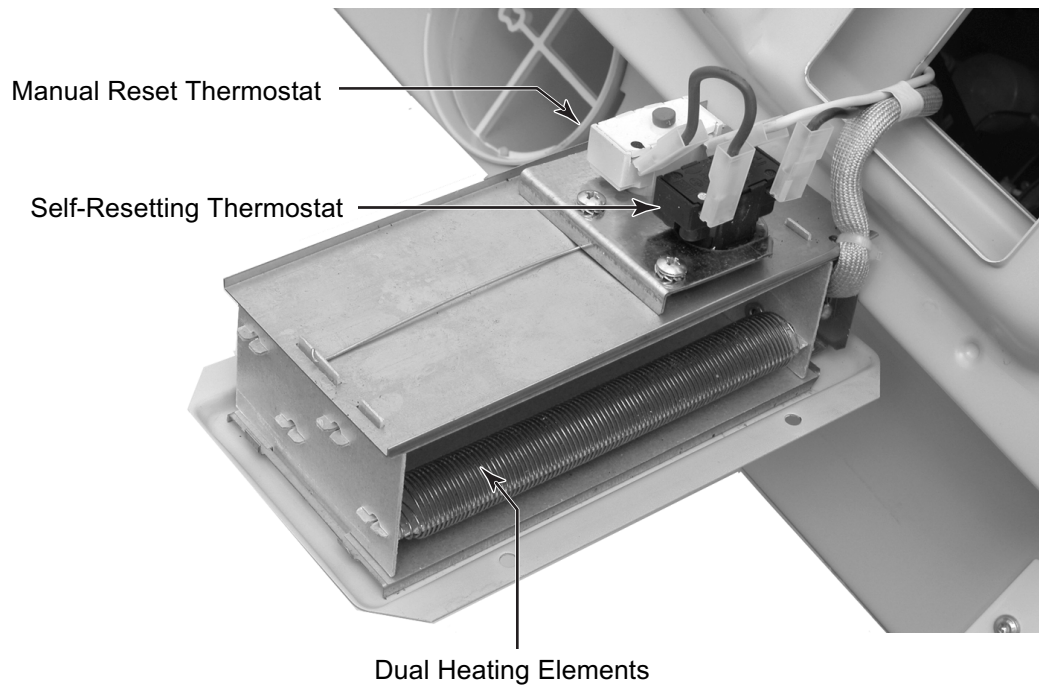

## AIRFLOW

Primary air is introduced into the dryer through the slots in the air intake cover.

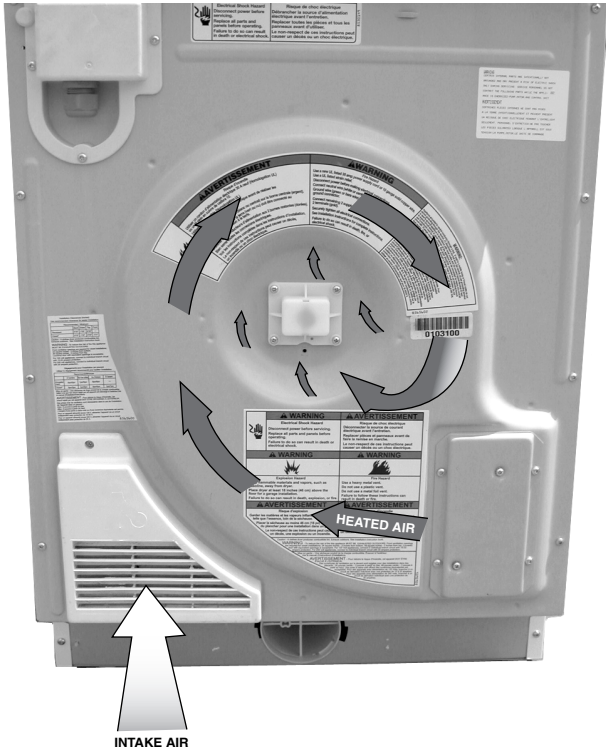

Some air is used to cool the fan and main motors. The fan motor pulls air from the drum, and creates a low pressure area. This pulls air across the heating elements, through the scroll in the rear panel, and into the drum to dry the clothes.



## DRUM MOTION

The main drive motor is reversible. It starts in one direction, stops, then reverses direction. It continues this throughout the drying cycle.

## MOISTURE SENSOR

A moisture sensor circuit is created through the drum baffles and the brushes on the outside of the drum. As wet clothes pass between the drum baffle and the stainless steel drum, the moisture creates a circuit that is read by the electronic control. The drum baffle contact is separated from the drum by an insulator, located under the contact strip.



Moisture Sensor Brushes

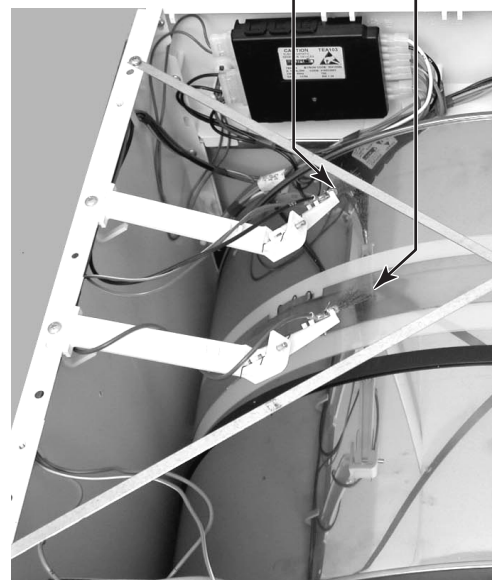

# DRYER USE



## STARTING THE DRYER

### **! WARNING**



#### **Explosion Hazard**

**Keep flammable materials and vapors, such as gasoline, away from dryer.**

**Do not dry anything that has ever had anything flammable on it (even after washing).**

**Failure to follow these instructions can result in death, explosion, or fire.**

Before using your dryer, wipe the dryer drum with a damp cloth to remove dust from storing and shipping.

**IMPORTANT:** Do not use fabric softener sheets in this dryer.

1. Clean the lint screen before or after each cycle.
2. Load clothes loosely into the dryer and close the door. Do not pack the dryer. Allow space for clothes to tumble freely.
3. Press the POWER button to turn the dryer on. The indicator light will glow to indicate that the power is on.

4. Press the TEMPERATURE button to select the recommended temperature setting for the type of load being dried.
5. Turn the cycle knob to the recommended setting for the type of load being dried.
6. After a short beep sounds, press the START button.

## STOPPING & RESTARTING

**To stop your dryer at any time,** turn the cycle knob to the STOP position, or open the door.

**To restart the dryer:**

1. Close the door.
2. Select a new cycle and temperature (if desired).
3. After the beep sounds, press the START button.

## CHANGING CYCLES AND TEMPERATURES

**To change the cycle or temperature after pressing Start:**

1. Open the dryer door.
2. Press the TEMPERATURE button to change the temperature (if desired).
3. Turn the cycle knob to the new desired position.
4. After the beep sounds, press the START button.

## LOADING

Load clothes loosely into the dryer. Do not pack the dryer. Allow space for clothes to tumble freely. The following chart shows the maximum load you can place in your compact dryer. Expect longer drying times.

### Loading Suggestions (Maximum Size Loads)

<b>Heavy Work Clothes</b>	<b>Towels</b>
3 jeans	8 bath towels
2 work pants	8 hand towels
3 work shirts	10 washcloths
<b>Permanent Press</b>	<b>Mixed Load</b>
1 double sheet	1 sheet (double or twin)
1 dress	4 pillowcases
1 blouse	2 shirts
2 slacks	2 blouses
3 shirts	6 T-shirts
6 handkerchiefs	6 shorts
	6 handkerchiefs
<b>Knits</b>	<b>Delicates</b>
1 pair pants	1 camisole
2 blouses	4 slips
4 shirts	6 undergarments
4 tops	1 set of sleepwear
2 dresses	

## DRYING, CYCLE, AND TEMPERATURE TIPS

Select the correct cycle and temperature for your load.

The dryer tumbles the load without heat during the last few minutes of all cycles to make the load easier to handle and to reduce wrinkling. After the cool-down cycle ends, the light flashes and an end-of-cycle signal sounds to indicate the cycle is complete.

### Drying Tips

- Follow care label directions when they are available.
- Remove the load from the dryer as soon as tumbling stops to reduce wrinkling. This is especially important for permanent press, knits, and synthetic fabrics.

- Avoid drying heavy work clothes with lighter fabrics. This could cause overdrying of lighter fabrics, leading to increased shrinkage or wrinkling.

### Cycle And Temperature Tips

- Dry most loads using an automatic cycle.
- Line dry bonded or laminated fabrics.

**NOTE:** If you have questions about drying temperatures for various loads, refer to the care label directions.

## CYCLES



### Automatic Cycles

Automatic cycles may be used for most loads. Automatic cycles give the best drying results in the shortest time. Drying time varies according to the type of fabric, size of the load, and dryness setting.

Dryness is determined by thermostats that react to the amount of moisture in the air exhausted from the dryer. Moist air indicates that clothes are still damp. Dry air indicates that moisture has been removed.

After drying a load, check the dryness.

- If the load is drier than you like, select a setting closer to Less Dry the next time you dry a similar load.
- If a load is not as dry as you like, complete drying using a Timed cycle. Select a setting closer to More Dry the next time you dry a similar load.

See following table for recommended cycles and temperature settings.

Fabric Type	Cycle	Temp Setting
<b>REGULAR</b>		
Heavy cottons and denims	More Dry	Normal
Cottons and linens	Normal	Normal
<b>SYNTHETICS</b>		
White and colorfast permanent press	Normal	Low
White and colorfast items that require ironing	Less Dry	Low
Polyester/acrylic blends, rayon, acetate	Damp Dry	Low
Washable silk and nylon	Damp Dry	Low

### Timed Dry

Use this cycle to get up to 60 minutes of heated drying time or to complete drying if items are still damp after the automatic cycle. Timed Dry is also useful for:

- Heavyweight items and work clothes that require a long drying time.
- Lightweight items, such as lingerie, blouses and knits that require a short drying time.

See following table for recommended cycles and temperature settings.

Fabric Type	Time (minutes)	Temp Setting
Heavy cottons and denims	60	Normal
Cottons and linens	40	Normal
White and colorfast permanent press	40	Low
White and colorfast items that require ironing	40	Low
Polyester/acrylic blends, rayon, acetate	40	Low
Washable silk and nylon	40	Low

### End of Cycle Signal

The dryer sounds a signal to let you know when the cycle is finished. The signal is not adjustable and cannot be turned off. The signal is helpful when you are drying permanent press, synthetics, and other items that should be taken out as soon as the dryer stops.

### Anti-Wrinkle

Anti-Wrinkle helps prevent wrinkles that form when clothes are not removed promptly at the end of a cycle. Anti-Wrinkle tumbles the load every minute until the cycle knob is set to the Stop position or the dryer door is opened.

During Anti-Wrinkle, the End of Cycle Signal will sound until the cycle knob is set to the Stop position or the dryer door is opened.

### TEMPERATURE CONTROL

The Temperature Control button lets you select between a normal and low drying temperature.



**NOTE:** Always refer to the care label on the garment to determine if it can be tumble dried.

#### Normal

The Normal temperature setting is for sturdy fabrics, such as cotton, linen and denim. If this button is not pressed in, the temperature setting is Normal.

#### Low

The Low setting is for synthetics, such as cotton/polyester blend, rayon, acetate, washable silk or nylon. If this button is pressed in, the temperature setting is Low.

— NOTES —



# COMPONENT ACCESS

This section instructs you on how to service each component inside the Whirlpool 24" Electric Dryer. The components and their locations are shown below.

## COMPONENT LOCATIONS

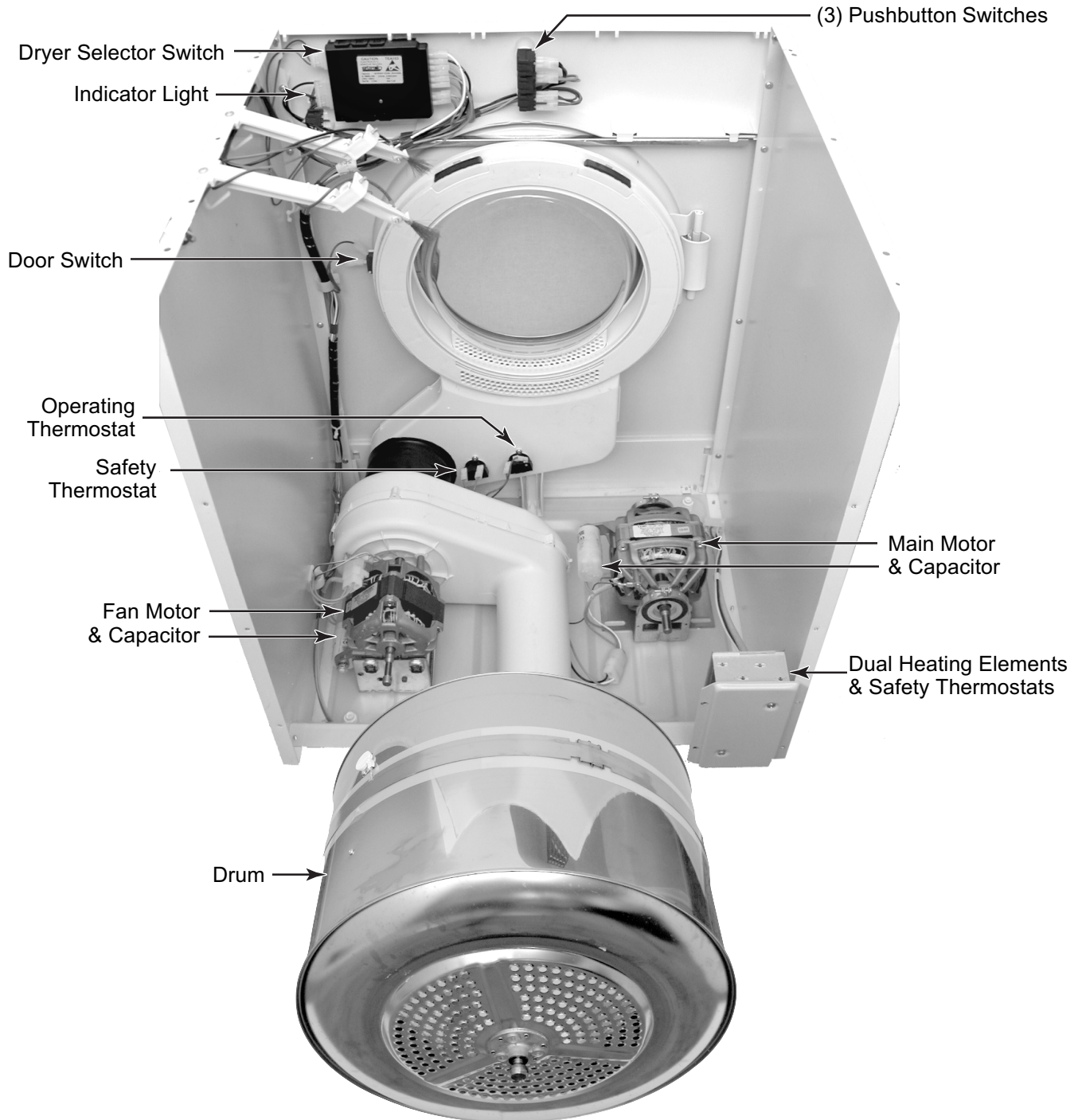

Viewed From Rear Of Dryer With Drum Removed

# REMOVING THE CONTROL SWITCHES & INDICATOR LIGHT

## !WARNING



### Electrical Shock Hazard

Disconnect power before servicing.  
Replace all parts and panels before operating.

Failure to do so can result in death or electrical shock.

1. Unplug dryer or disconnect power.
2. Pull the dryer away from the wall so you can access the rear of the unit.
3. Remove the two screws from the back of the top cover.



4. Lift the rear of the top cover, unhook it from the front, and remove the cover.

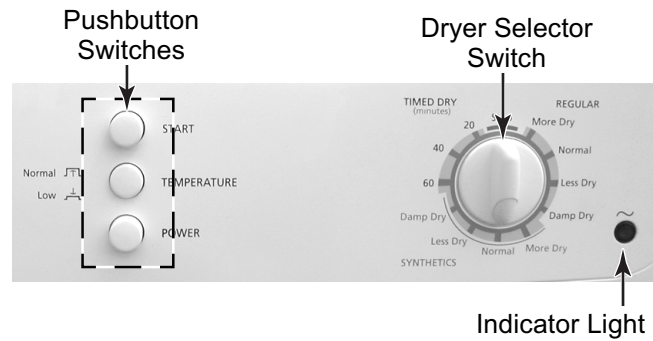
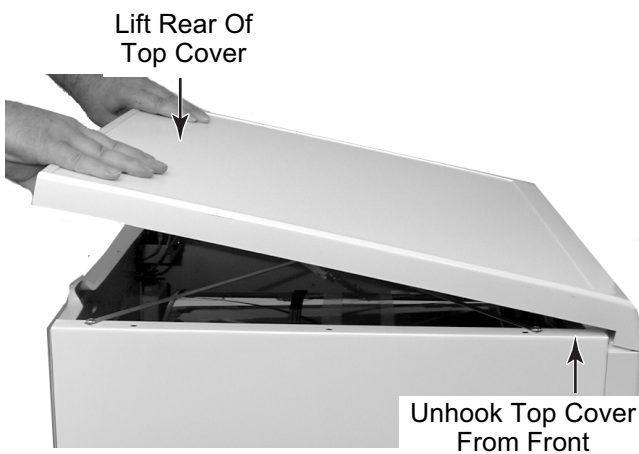

5. To remove a pushbutton switch:

- a) Using a small-bladed screwdriver, press the two locking tabs on the sides of the pushbutton switch toward the switch body, and pull the switch out of the mounting location on the control panel.

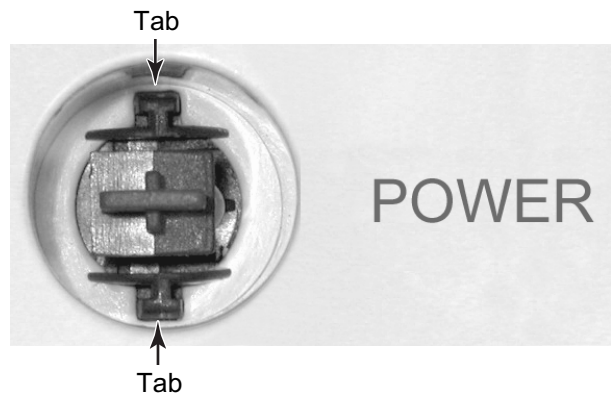

- b) Disconnect the wires from the pushbutton switch terminals. **NOTE:** The wiring for the three pushbutton switches is shown on the next page.

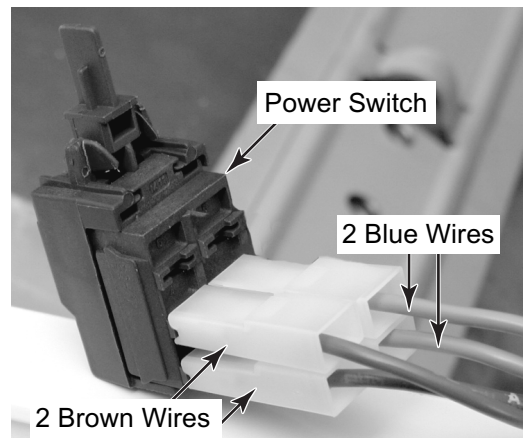

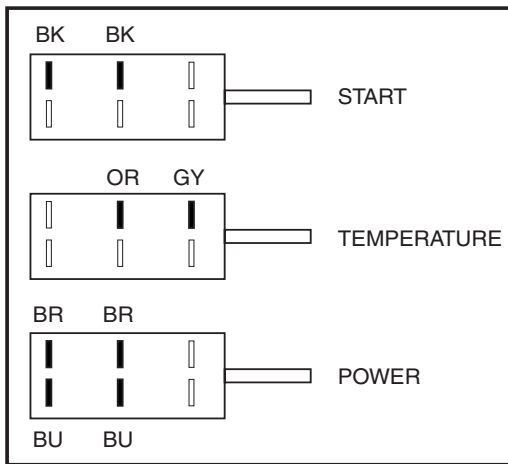

Pushbutton Switch Wiring

6. **To remove the dryer selector switch:**

- a) Pull the knob off the selector switch shaft.
- b) Remove the two screws from the switch.



- c) Disconnect the wire connectors from the dryer selector switch terminals. **NOTE:** The 6- and 10-pin connectors have a locking tab. Raise the tab to release these connectors.

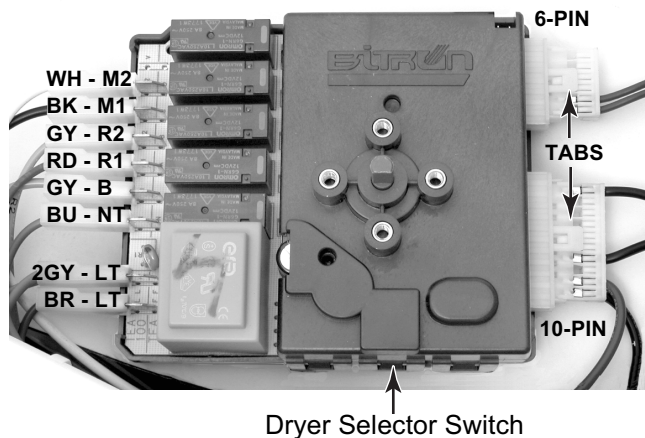

7. **To remove the indicator light:**

- a) Remove the dryer selector switch (see step 6).
- b) Push out on the locking sections of the indicator light holder, and pull the indicator light out of the holder.

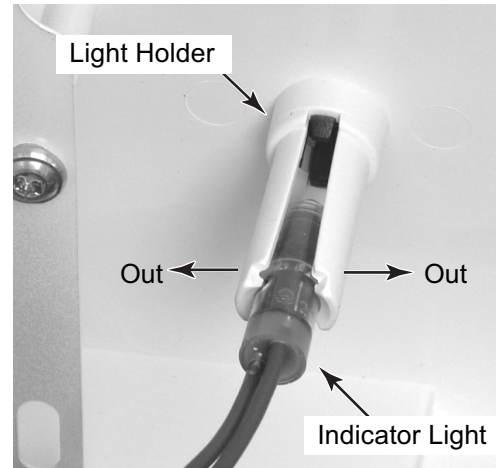

- c) Raise the locking tab and disconnect the 6-pin connector with the two red wires from the dryer selector switch.

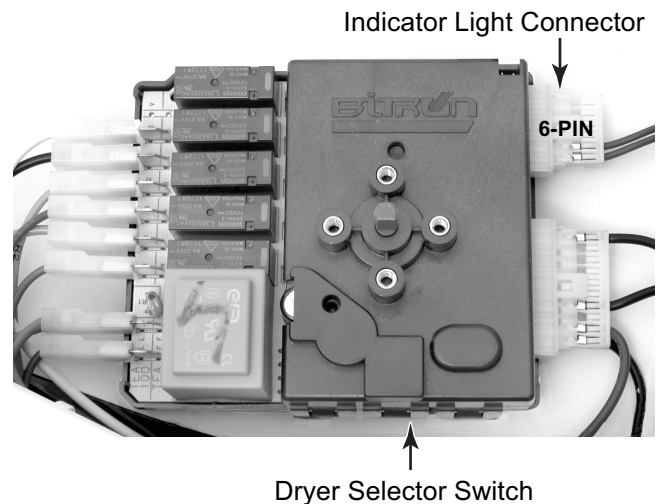

## REMOVING THE DOOR SWITCH

### **!WARNING**



#### **Electrical Shock Hazard**

**Disconnect power before servicing.**

**Replace all parts and panels before operating.**

**Failure to do so can result in death or electrical shock.**

1. Unplug dryer or disconnect power.
2. Remove the top cover from the dryer (see page 4-2).
3. Open the dryer door and remove the two door switch screws.



4. Disconnect the wire connectors from the door switch terminals and pull the switch off the mounting plate.

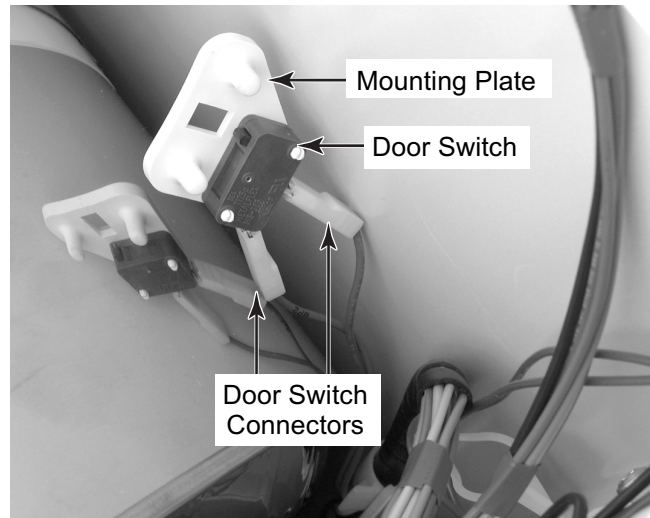



# REMOVING THE SAFETY THERMOSTATS & THE DUAL HEATING ELEMENTS

## ⚠️ WARNING



**Electrical Shock Hazard**  
**Disconnect power before servicing.**  
**Replace all parts and panels before operating.**  
**Failure to do so can result in death or electrical shock.**

1. Unplug dryer or disconnect power.
2. Pull the dryer away from the wall so that you can access the rear of the unit.
3. Remove the four outer screws from the heater and thermostat access panel and remove the panel. **NOTE:** Do not remove the two heater screws on the access panel. They secure the heating elements and thermostats to the panel.

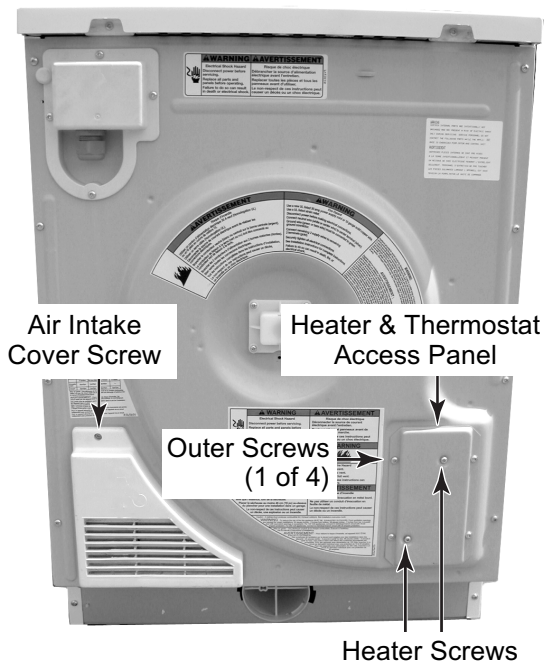

4. To remove the safety thermostats:
  - a) Remove the two screws from the thermostat bracket and remove the bracket.
  - b) Remove the wire connectors from the thermostat you are servicing.

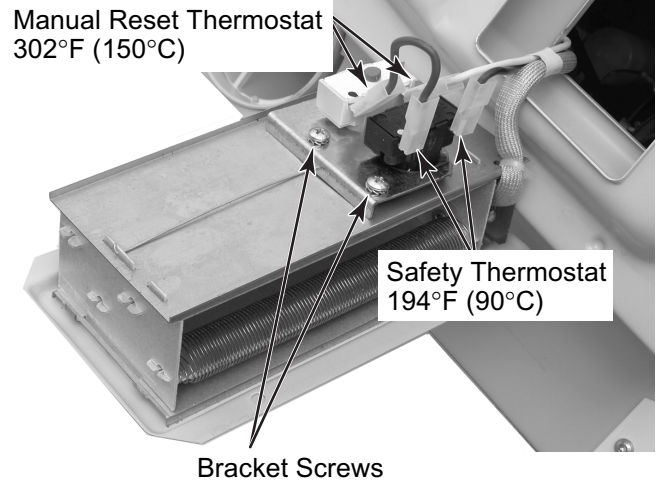

5. To remove the dual heating elements:
  - a) Remove the two thermostats from the heater bracket (see step 4).
  - b) Remove the screw from the air intake cover and remove the cover (see the left photo).
  - c) Disconnect the heater & thermostat connector from the main harness, located behind the vent cover opening.
  - d) Remove the two screws from the heater bracket on the access panel (see the left photo) and remove the bracket from the panel.

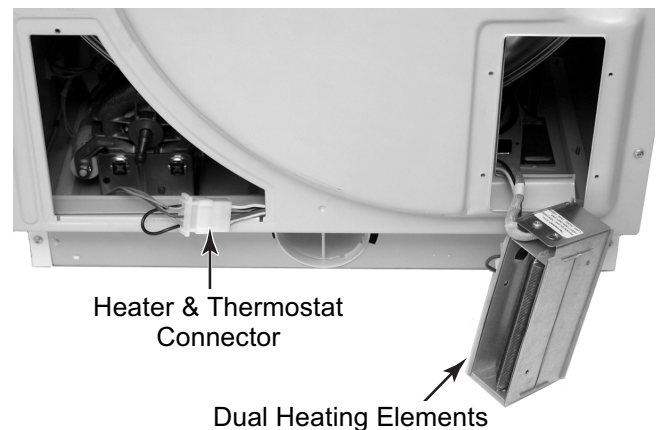

## REMOVING THE BELT AND THE DRUM

### **!WARNING**



#### **Electrical Shock Hazard**

**Disconnect power before servicing.  
Replace all parts and panels before  
operating.**

**Failure to do so can result in death or  
electrical shock.**

1. Unplug dryer or disconnect power.
2. Pull the dryer away from the wall so that you can access the rear of the unit.
3. Remove the top cover from the dryer (see page 4-2).
4. Remove the four screws from the cross-braces on top of the dryer and remove the braces.

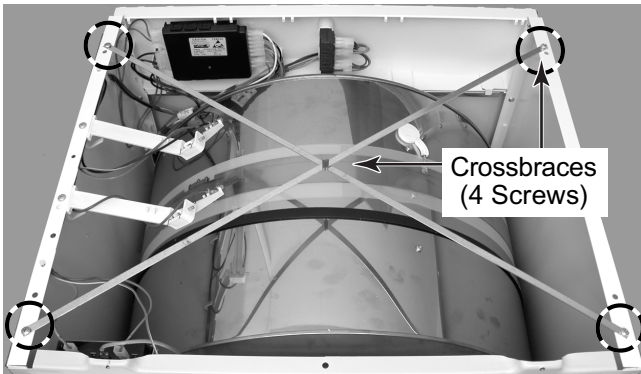

5. Disconnect the blue and brown wires from the AC Line terminal block, then remove the hex nut from the green ground wires, and remove the main harness ground wire from the rear panel (see the top right photo).

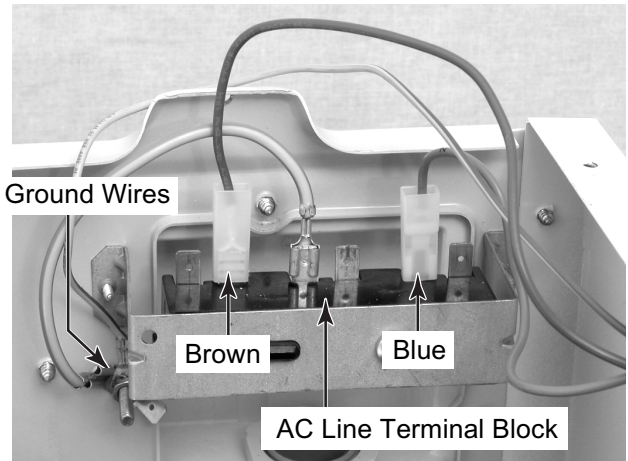

6. Remove the four outer screws from the heater and thermostat access panel, and remove the panel assembly from the dryer. Do not remove the two heater (inside) screws.
7. Remove the air intake cover screw and remove the cover.

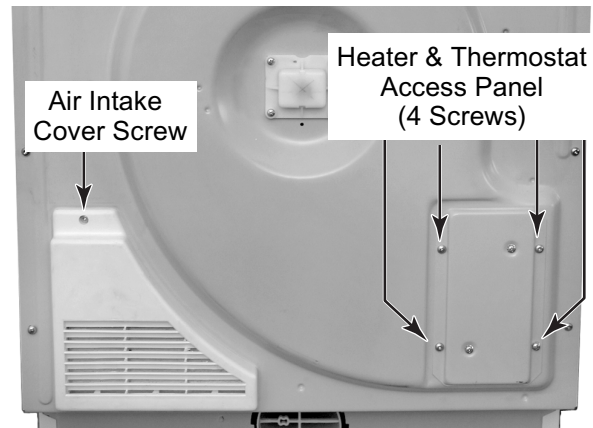

8. Disconnect the heater & thermostat connector from the wire harness.



9. Lay the dryer on its front on a padded surface to protect the finish.
10. Remove the four screws from the support flange and remove it and the drum shaft supports. **NOTE:** Be careful not to get any grease on your clothing.

**REASSEMBLY NOTE:** Be sure to position the pins on the drum shaft supports facing down toward the rear panel.

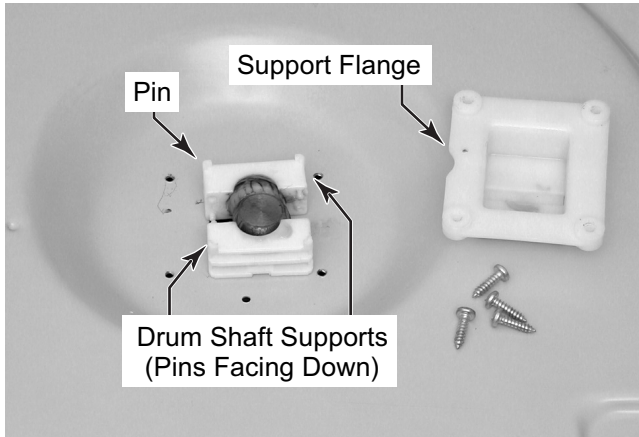

11. Remove the eight T-20 Torx screws from the rear panel and remove the panel from the dryer.



8 Rear Panel Screws

**REASSEMBLY NOTE:** When reassembling the drum and belt, attach the support flange to the rear panel, and then slide the rear panel into position, and install the screws.

12. **To remove the belt from the drum:**
  - a) Pull the belt off the motor pulley.
  - b) Pull the belt off the drum and remove it.

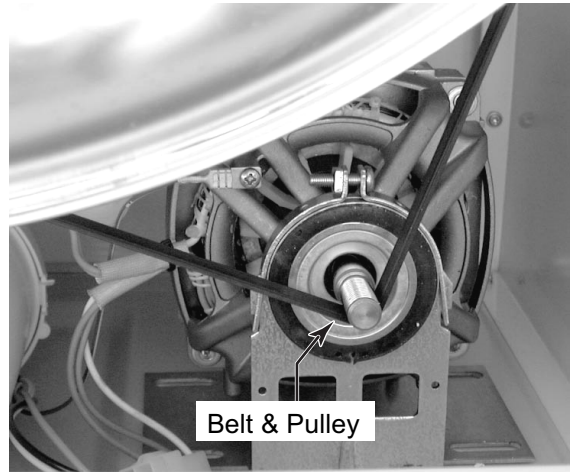

13. **To remove the drum:**
  - a) Remove the belt from the drum (see step 12).
  - b) Lift the drum straight up and out of the dryer cabinet.





# REMOVING THE OPERATING & SAFETY THERMOSTATS

## ⚠️ WARNING



### Electrical Shock Hazard

Disconnect power before servicing.

Replace all parts and panels before operating.

Failure to do so can result in death or electrical shock.

1. Unplug dryer or disconnect power.
2. Pull the dryer away from the wall so that you can access the rear of the unit.
3. Remove the drum and belt from the dryer (see pages 4-6 and 4-7 for the procedure).

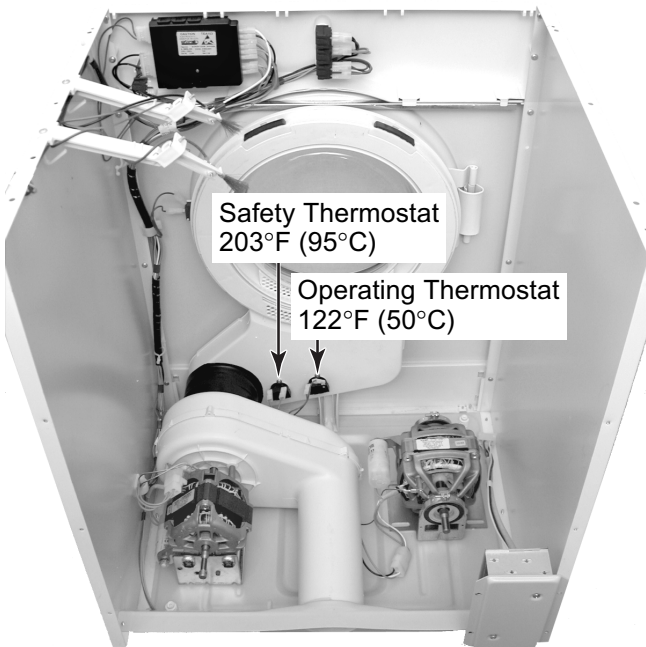

4. Remove the wire connectors from the thermostat you are servicing.
5. Remove the two T-20 Torx screws from the thermostat and remove it from the dryer. **NOTE:** The operating thermostat is identified by a green dot on the body. The safety thermostat has a white dot on its body.

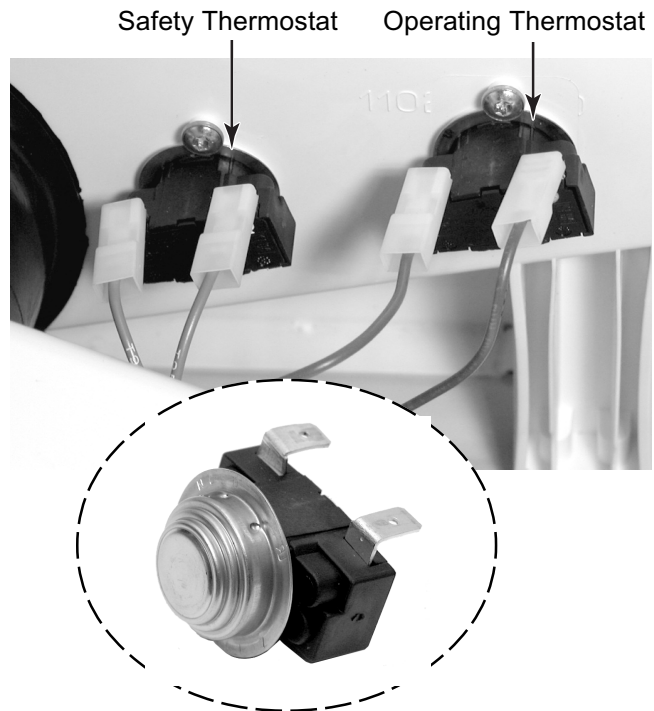



## REMOVING THE FRONT SLIDE BLOCKS & REAR SEAL

### **!WARNING**



#### **Electrical Shock Hazard**

**Disconnect power before servicing.**

**Replace all parts and panels before operating.**

**Failure to do so can result in death or electrical shock.**

1. Unplug dryer or disconnect power.
2. Pull the dryer away from the wall so that you can access the rear of the unit.
3. Remove the drum and belt from the dryer (see pages 4-6 and 4-7 for the procedure).



4. To remove the two front slide blocks, lift the front locking tab on each of the blocks, and pull them out of the housing.

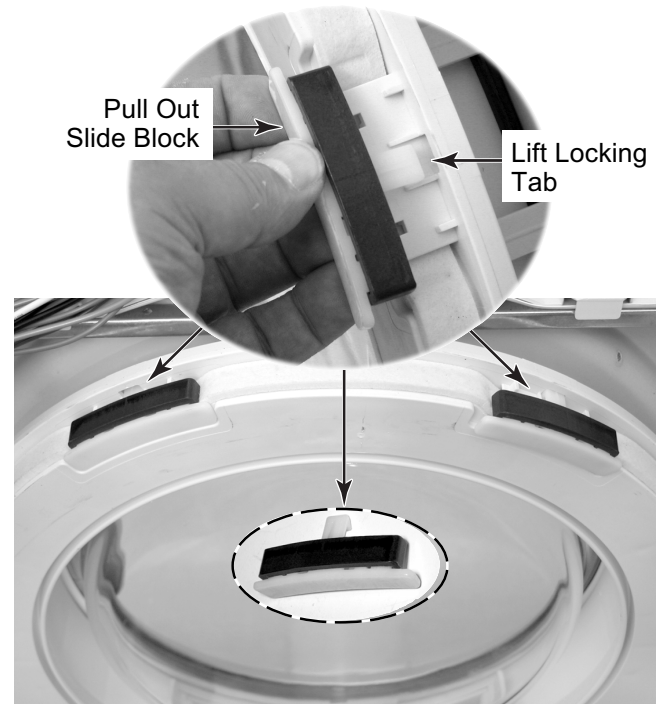

5. To remove the rear seal:
  - a) Loosen the spring clamp band screw and remove the band from the drum seal.
  - b) Pull the rear seal off the rear panel flange.

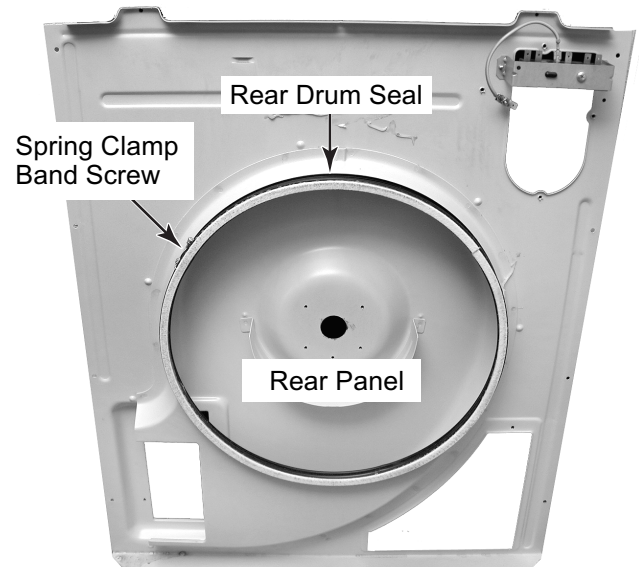

## REMOVING THE MAIN AND FAN MOTORS & CAPACITORS

### **!WARNING**



#### **Electrical Shock Hazard**

**Disconnect power before servicing.  
Replace all parts and panels before  
operating.**

**Failure to do so can result in death or  
electrical shock.**

1. Unplug dryer or disconnect power.
2. Pull the dryer away from the wall so that you can access the rear of the unit.
3. Remove the drum and belt from the dryer (see pages 4-6 and 4-7 for the procedure).

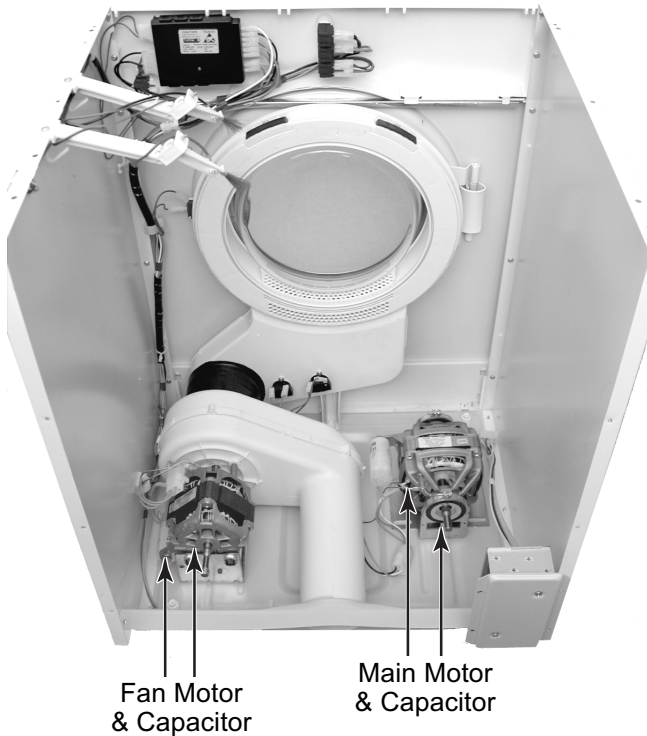

4. To remove either of the motor capacitors:

- a) Loosen the 1/2" hex-nut and star washer on the capacitor mounting stud and remove the capacitor from the motor.
- b) Pull the round terminal cover off the motor capacitor.
- c) Disconnect the brown and blue wires (main motor), or the red and blue wires (fan motor), from the motor capacitor terminals.

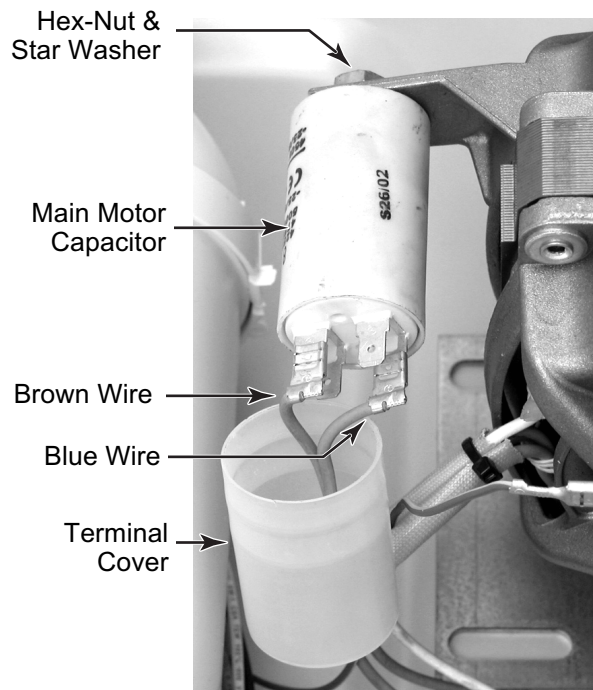

5. **To remove the main motor:**

- a) Remove the motor capacitor from the motor (see step 4).
- b) Remove the terminal cover from the capacitor wires.
- c) Disconnect the green ground wire from the motor ground terminal.
- d) Disconnect the motor connector from the main harness.

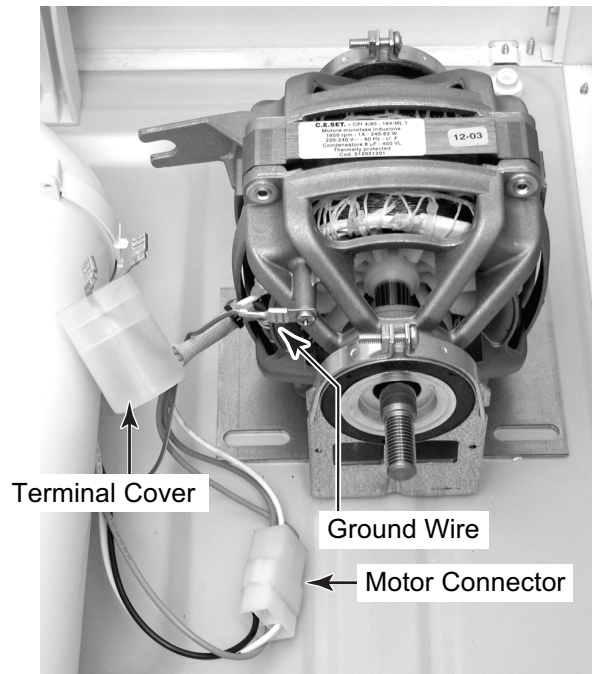

- e) While holding the motor in place, remove the four 20 mm hex-head motor mounting screws from the bottom of the cabinet, and remove the motor.

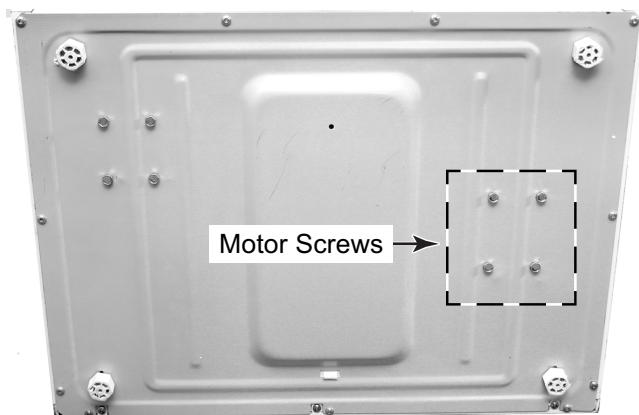

6. **To remove the fan motor:**

- a) Disconnect the two green ground wires from the motor ground terminal.
- b) Disconnect the motor connector from the main harness.

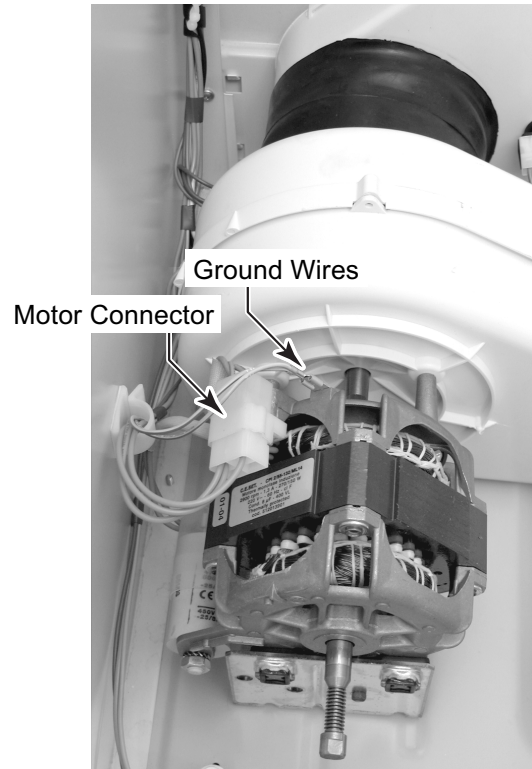

- c) Remove the four 20 mm hex-head motor mounting screws from the bottom of the cabinet.

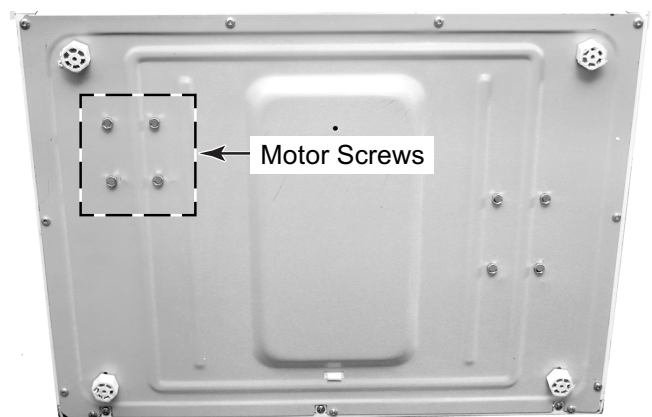

**Continued on the next page.**



- d) Remove the fan motor assembly from the bottom of the dryer.

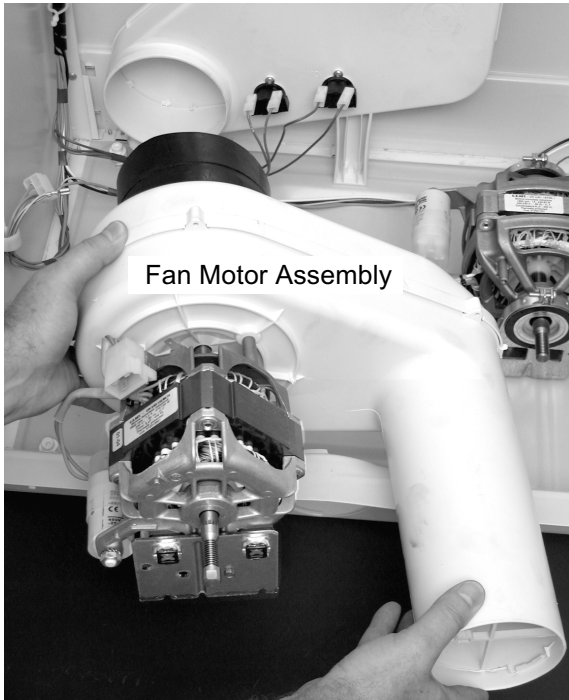

- e) Remove the rubber coupler from the fan housing flange. **NOTE:** If the coupler is on the vent flange instead of the fan housing, leave it there.
- f) Unsnap the front half of the fan housing from the rear half and remove it. **NOTE:** There may be screws holding the fan housing halves together. If so, remove them before separating the halves.

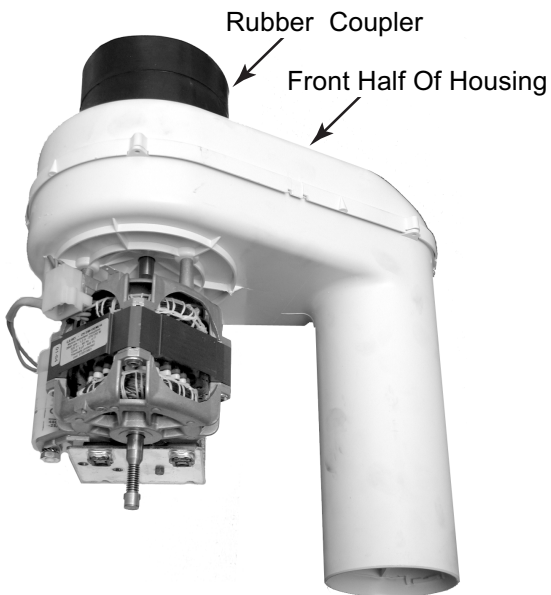

- g) While you hold the opposite end of the fan motor shaft with a pair of pliers, remove the 1/2" locknut from the fan end of the shaft, and remove the fan.



- h) Remove the three screws from the fan housing and remove the housing from the fan motor.



- i) Remove the motor capacitor from the motor (see step 4 on page 4-10 for the procedure).

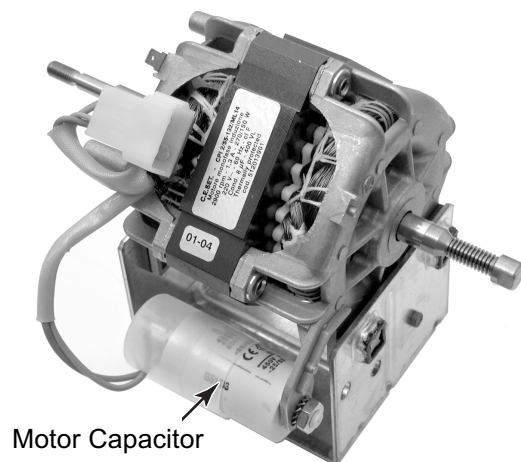

# COMPONENT TESTING

Before testing any of the components, perform the following checks:

- Control failure can be the result of corrosion on connectors. Therefore, disconnecting and reconnecting wires will be necessary throughout test procedures.
- All tests/checks should be made with a VOM or DVM having a sensitivity of 20,000 ohms-per-volt DC, or greater.
- Check all connections before replacing components, looking for broken or loose wires, failed terminals, or wires not pressed into connectors far enough.
- Resistance checks must be made with power cord unplugged from outlet, and with wiring harness or connectors disconnected.
- Unless stated otherwise, make all resistance checks by disconnecting the component connector at the electronic control.



## ! WARNING

### Electrical Shock Hazard

**Disconnect power before servicing.  
Replace all parts and panels before operating.  
Failure to do so can result in death or electrical shock.**

## PUSHBUTTON SWITCHES

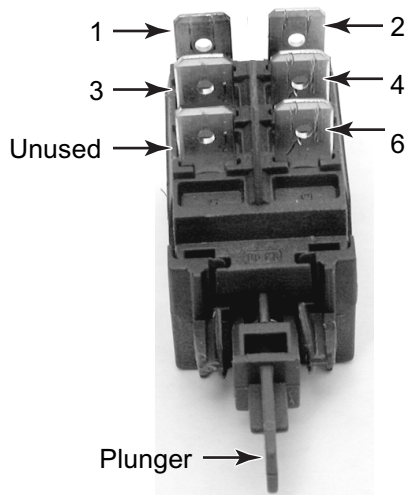

2. Disconnect the wires from the terminals of the pushbutton switch you are testing.
3. Set the ohmmeter to the R x 1 scale.
4. Depending on the pushbutton switch terminal configuration, touch the ohmmeter test leads to the following switch terminals. The meter should indicate either an open (infinite), or a closed ( $0 \Omega$ ) circuit.  
Terminals 1 - 3  
Terminals 2 - 4  
Terminals 4 - 6
5. Press the plunger, and the switch should change states (from open to closed, or closed to open).

Refer to page 4-2 for the procedure for servicing the pushbutton switches.

1. Unplug dryer or disconnect power.



## ⚠ WARNING

### Electrical Shock Hazard

**Disconnect power before servicing.**

**Replace all parts and panels before operating.**

**Failure to do so can result in death or electrical shock.**

### DOOR SWITCH

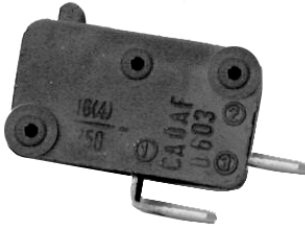

Refer to page 4-4 for the procedure for servicing the door switch.

1. Unplug dryer or disconnect power.
2. Disconnect the wires from the door switch terminals.
3. Set the ohmmeter to the R x 1 scale.
4. Touch the ohmmeter test leads to the door switch terminals. The meter should indicate an open (infinite) circuit.
5. Press the actuator button, and the switch should indicate a closed (0  $\Omega$ ) circuit.

### DUAL HEATING ELEMENTS

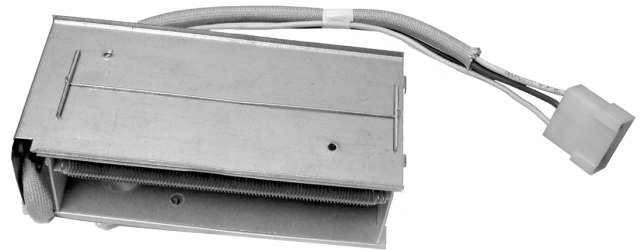

Refer to page 4-5 for the procedure for servicing the dual heating elements.

1. Unplug dryer or disconnect power.
2. Disconnect the heater and thermostat connector from the wiring harness.
3. Set the ohmmeter to the R X 1 scale.
4. Touch the ohmmeter test leads to the connector pins with the white and red wires. The meter should indicate between 68 and 82  $\Omega$
5. Touch the ohmmeter test leads to the connector pins with the white and black wires. The meter should indicate between 24 and 35  $\Omega$



## ⚠️ WARNING

### Electrical Shock Hazard

**Disconnect power before servicing.**

**Replace all parts and panels before operating.**

**Failure to do so can result in death or electrical shock.**

### THERMOSTATS

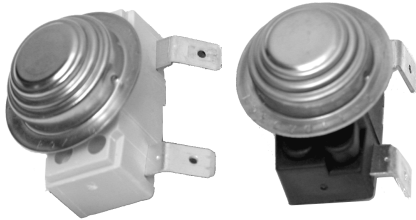

Refer to pages 4-5 and 4-8 for the procedures for servicing the thermostats.

1. Unplug dryer or disconnect power.
2. Disconnect the wire connectors from the thermostat you are testing.
3. Set the ohmmeter to the R X 1 scale.
4. Touch the ohmmeter test leads to the thermostat terminals. The meter should indicate a closed ( $0 \Omega$ ) circuit.

### MAIN & FAN MOTOR CAPACITORS



Refer to page 4-10 for the procedure for servicing the motor capacitors.

1. Unplug dryer or disconnect power.
2. Disconnect the wire connectors from the motor capacitor terminals.
3. Set the ohmmeter to the R X 10K scale.
4. Touch the ohmmeter test leads to the motor capacitor terminals. The meter should indicate several ohms, and then gradually return towards infinity.



## ⚠ WARNING

### Electrical Shock Hazard

**Disconnect power before servicing.**

**Replace all parts and panels before operating.**

**Failure to do so can result in death or electrical shock.**

### MAIN MOTOR

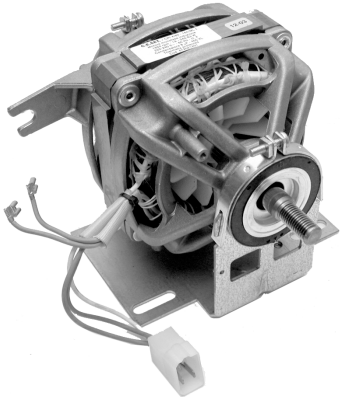

Refer to page 4-10 for the procedure for servicing the main motor.

1. Unplug dryer or disconnect power.
2. Disconnect the main motor connector from the wiring harness connector.
3. Set the ohmmeter to the R x 1 scale.
4. Touch the ohmmeter test leads to the motor connector pins with the following wire colors:
  - a) White and brown wires. The meter should indicate between 28 and 40  $\Omega$ .
  - b) White and blue wires. The meter should indicate between 25 and 40  $\Omega$ .
  - c) Blue and brown wires. The meter should indicate between 58 and 70  $\Omega$ .

### FAN MOTOR

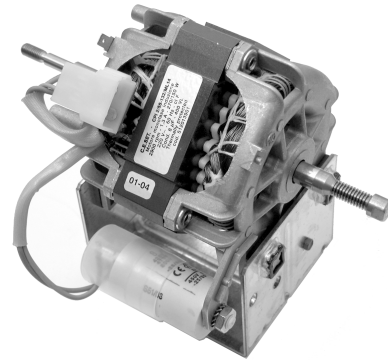

Refer to page 4-10 for the procedure for servicing the fan motor.

1. Unplug dryer or disconnect power.
2. Disconnect the wire harness connector from the fan motor terminals.
3. Set the ohmmeter to the R x 1 scale.
4. Touch the ohmmeter test leads to the motor connector pins with the following wire colors:
  - a) Violet and blue wires. The meter should indicate between 26 and 38  $\Omega$ .
  - b) Violet and red wires. The meter should indicate between 26 and 38  $\Omega$ .
  - c) Blue and red wires. The meter should indicate between 58 and 72  $\Omega$ .



# WIRING DIAGRAM

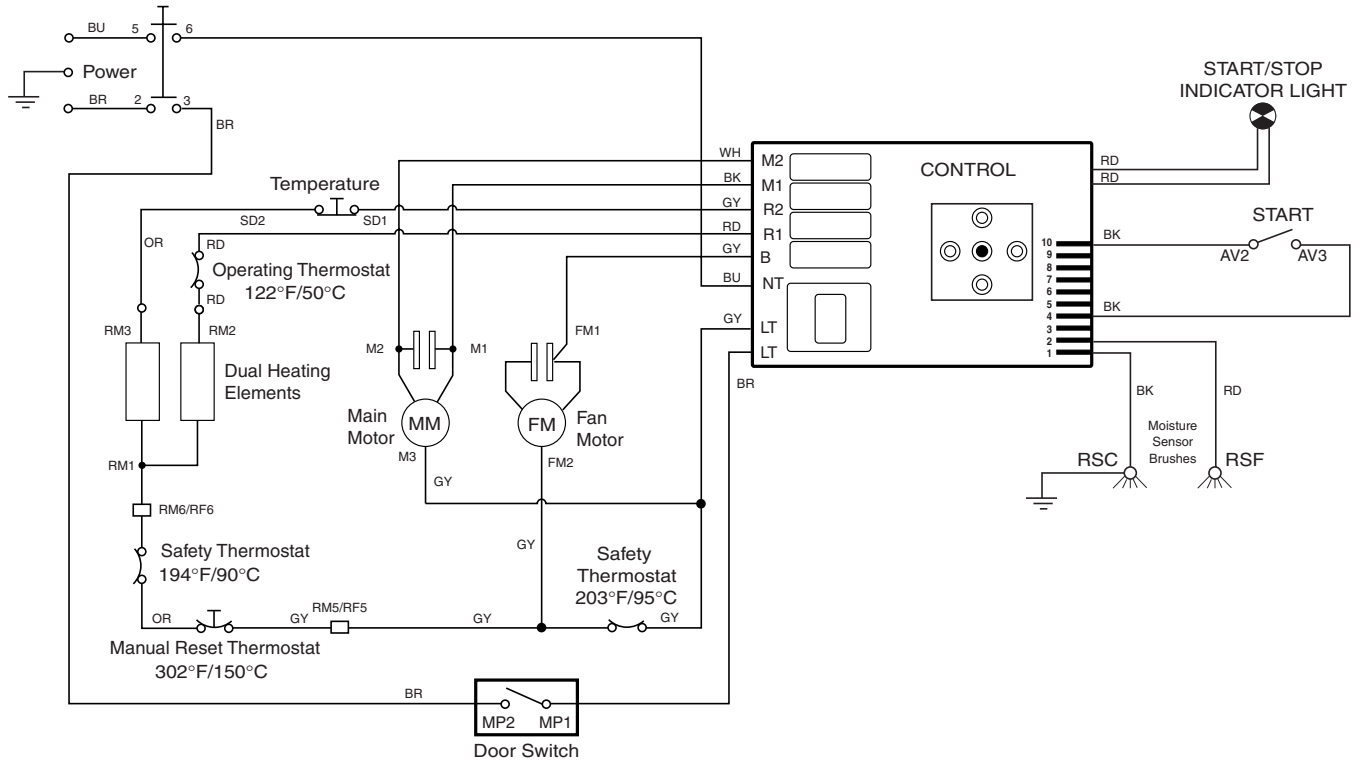

— NOTES —

# **PRODUCT SPECIFICATIONS AND WARRANTY INFORMATION SOURCES**

***IN THE UNITED STATES:***

**FOR PRODUCT SPECIFICATIONS AND WARRANTY INFORMATION CALL:**

FOR WHIRLPOOL PRODUCTS: 1-800-253-1301  
FOR KITCHENAID PRODUCTS: 1-800-422-1230  
FOR ROPER PRODUCTS: 1-800-447-6737

**FOR TECHNICAL ASSISTANCE WHILE AT THE CUSTOMER'S HOME CALL:**

THE TECHNICAL ASSISTANCE LINE: 1-800-253-2870

**HAVE YOUR STORE NUMBER READY TO IDENTIFY YOU AS AN  
AUTHORIZED SERVICER**

**FOR LITERATURE ORDERS:**

PHONE: 1-800-851-4605

**FOR TECHNICAL INFORMATION AND SERVICE POINTERS:**

[www.servicematters.com](http://www.servicematters.com)

---

***IN CANADA:***

**FOR PRODUCT SPECIFICATIONS AND WARRANTY INFORMATION CALL:**

1-800-461-5681

**FOR TECHNICAL ASSISTANCE WHILE AT THE CUSTOMER'S HOME CALL:**

THE TECHNICAL ASSISTANCE LINE: 1-800-488-4791

**HAVE YOUR STORE NUMBER READY TO IDENTIFY YOU AS AN  
AUTHORIZED SERVICER**

