



Spare Parts Catalogue

Dishwashers \ 3000 Std Tank Series
Type: DW20.1US
Model: D3120 US White Bi

Prod. No: 107312000
March 14th 2005

AM Appliances Group

P.O. Box 851805 • Richardson • TX 75085-1805
789 N. Grove Road • Suite 103 • Richardson • TX 75081

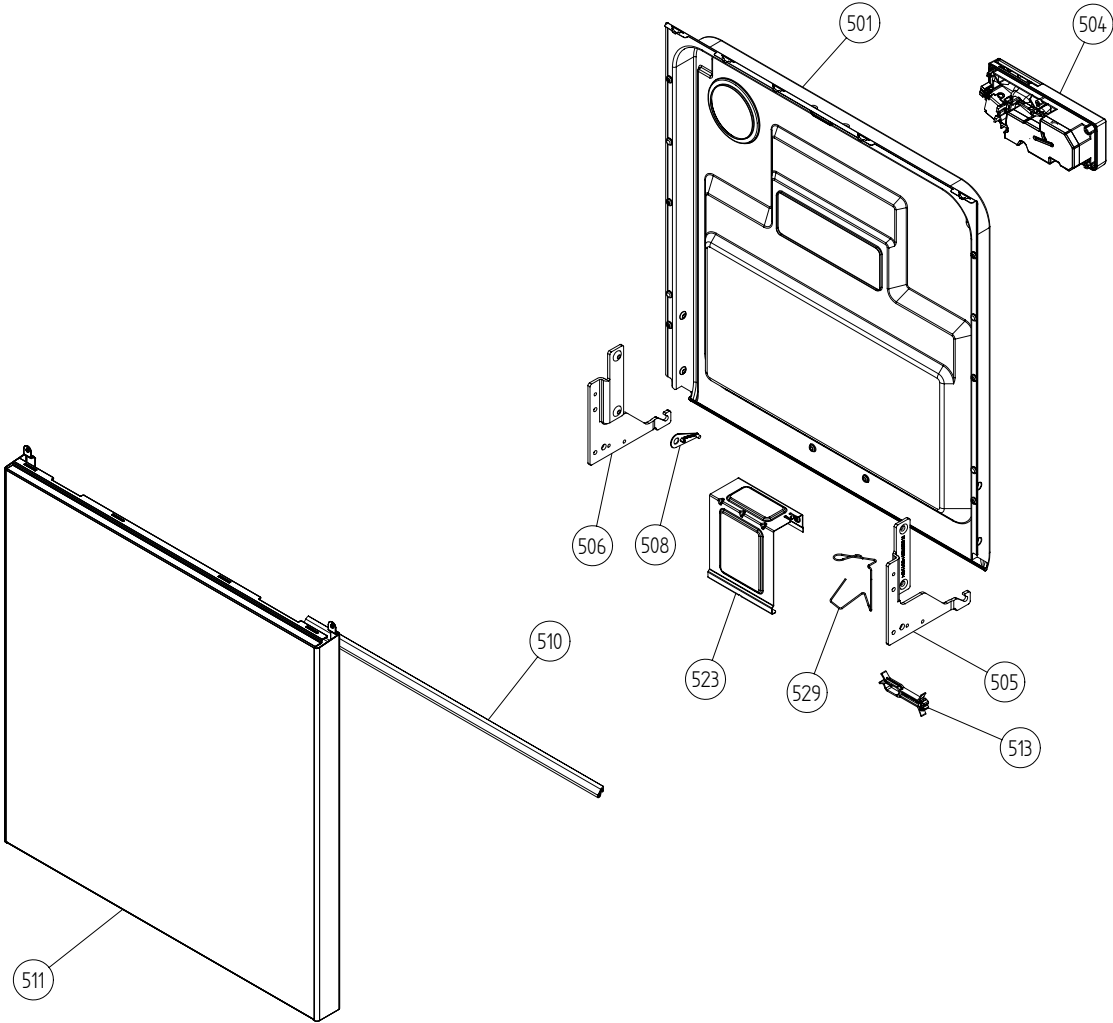

Inner door, panel and related parts

ASKO, D3120 US - White Bi (DW20.1US)

Pos	Spare part No.	Description	Qty	Comment
501	8801243	Door Inner w/Insul.	1 Pcs	
501-a	8900646	Screw 20 Torx SS	6 Pcs	
501-b	8902121	Screw	4 Pcs	
504	8073804	Combidisp. Optical 120V	1 Pcs	
504-a	8071916	Subs to 8071918	1 Pcs	
504-b	8071917	CAP RINSE AGENT	1 Pcs	
504-c	8071918	Detergent Lid Complete	1 Pcs	
504-d	8072288	Sealing Strip Combbidisp.	1 Pcs	
504-e	8075778	Bracket Comb. Dispenser	2 Pcs	
504-f	8902087	Screw Plastic Housing 20 Torx	6 Pcs	
505	8057524	Hinge Right DW 05/06	1 Pcs	
505-a	8057530	Screw hinge 05	1 Pcs	
505-b	33500262	Nut Term Block	1 Pcs	
506	8057525	Hinge left DW 05/06	1 Pcs	
506-a	8057530	Screw hinge 05	1 Pcs	
506-b	33500262	Nut Term Block	1 Pcs	
507	8057530	Screw hinge 05	2 Pcs	
507-a	33500262	Nut Term Block	2 Pcs	
508	8057948	Slide washer hinge bearing 05	2 Pcs	
510	8057949	DOOR SEALVIKING	1 Pcs	
510	8060254	Lower SealInner Door 05/06 DW	1 Pcs	
511	8071106-0	DOOR OUTER THICK WHITE	1 Pcs	
511-a	8900646	Screw 20 Torx SS	6 Pcs	
513	8074015	CABLE BRACKET DOOR	1 Pcs	
523	8057984	Push Button Grey 1706/1716 DW	1 Pcs	
523-a	8900646	Screw 20 Torx SS	2 Pcs	
523-b	8902357	Screw	2 Pcs	
529	8073612	BRACKET FOR HARNESS	1 Pcs	

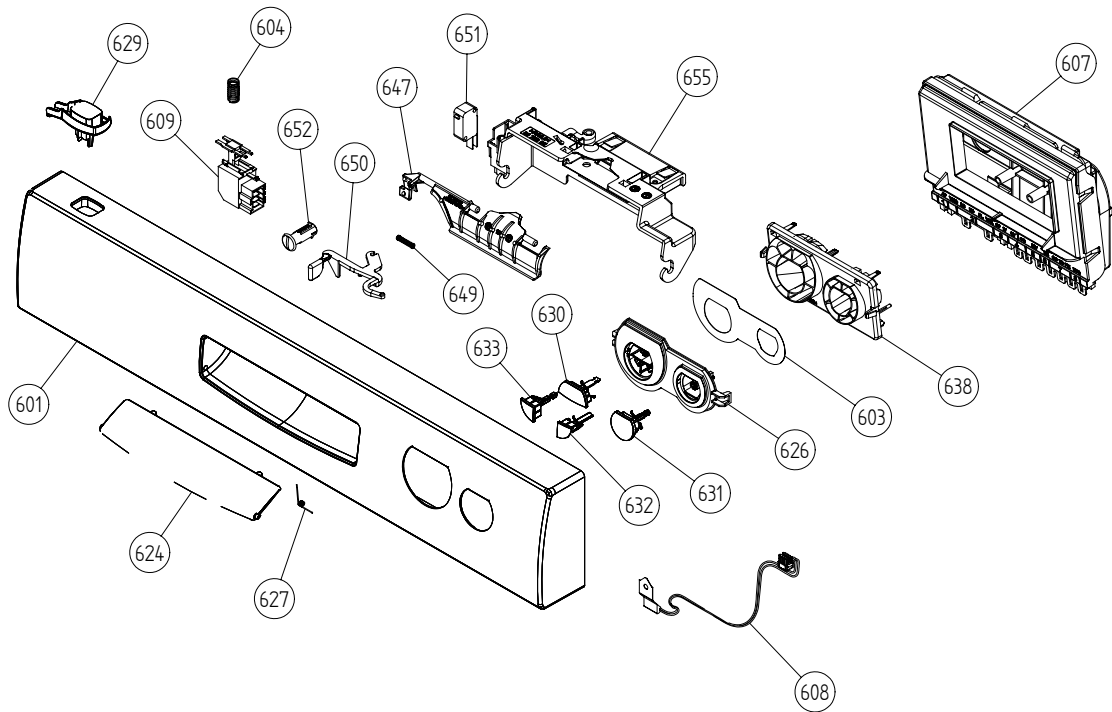

Control panel and related parts

ASKO, D3120 US - White Bi (DW20.1US)

Pos	Spare part No.	Description	Qty	Comment
601	8075752-0-UL	Panel Graph	1 Pcs	
602	8075296	Prog. Info. Label ES	1 Pcs	
602	8075156	Prog. Info. Label	1 Pcs	
602	8075157	Prog. Info. Label	1 Pcs	
603	8074957	Decor Plate Graphic	1 Pcs	
604	8074277	SPRING MAIN SWITCH	1 Pcs	
607	8801224	Control Unit Compl. DW20.1	1 Pcs	
608	8073788	Thermistor	1 Pcs	
609	8073782	MAIN PUSH SWITCH	1 Pcs	
614	8073888	SUBS TO 8075736	1 Pcs	
617	8073889	CABLE SET FLOW SENSOR	1 Pcs	
618	8073890	SUBS TO 8075738	1 Pcs	
619	8073886	Cable Set Door	1 Pcs	
622	8073883	Cable Set Drain	1 Pcs	
624	8073470-0	COVER FOR HANDLE WHITE	1 Pcs	
626	8074000	Lens DW320	1 Pcs	
627	8074464	SPRING FOR LID HANDLE	1 Pcs	
629	8075078-0	Push Button Main Switch Graphi	1 Pcs	
630	8075082-0	Push Button Prog.	1 Pcs	
631	8075081-0	Push Button Start/Stop	1 Pcs	
632	8075084-0	Push Button Right Opt.	1 Pcs	
633	8075083-0	Push Button Left Opt.	1 Pcs	
638	8074008	Light Guide	1 Pcs	
647	8075550	Subs to 8072906	1 Pcs	
647	8072906	Catch Handle	1 Pcs	
649	8072908	SPRING LOCK	1 Pcs	
650	8072907	Control Arm Safety Catch	1 Pcs	
651	8073836	MICROSWITCH DOOR	1 Pcs	
652	8057545	Rotary catch child safety 05	1 Pcs	
655	8072905	Protection Catch	1 Pcs	
655-a	8902085	Screw 20T for Plastic	2 Pcs	
690	8075233	INSTR D3120-322 USA ENG	1 Pcs	

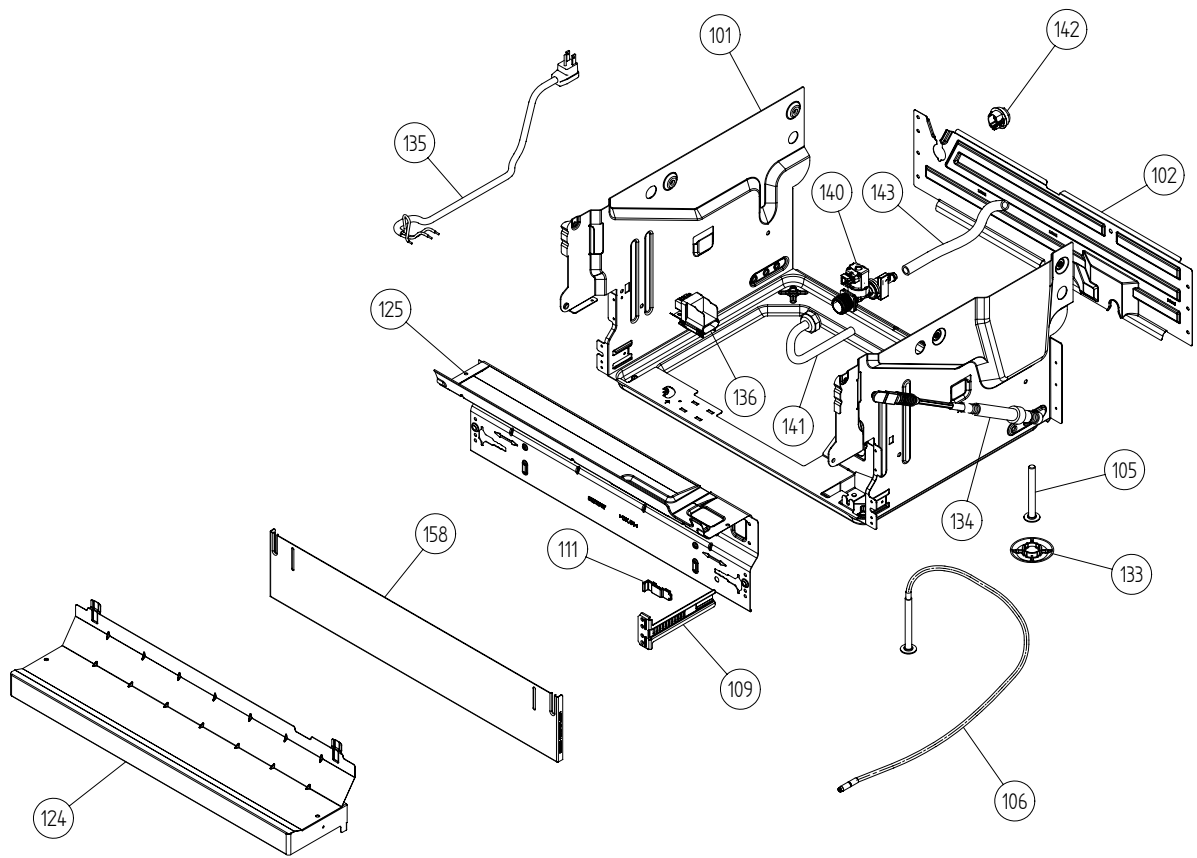

Base and related parts

ASKO, D3120 US - White Bi (DW20.1US)

Pos	Spare part No.	Description	Qty	Comment
101	8074450	Bottom Outer DW20	1 Pcs	
101-a	8901104	Screw 20 Torx Machine	2 Pcs	
101-b	8901110	Screw w/ORing DW 05/06 25T	4 Pcs	
102	8073880	REAR PANEL	1 Pcs	
102-a	8902357	Screw	5 Pcs	
105	8074877	Foot	2 Pcs	
106	8073647	FOOT ADJUSTABLE FROM FRONT CPL	1 Pcs	
109	8057549	Bracket/Toe Kick 05/06 DW	2 Pcs	
111	8073481-49	Spring Kicking Plate L. Gray	2 Pcs	
124	8074293-0	LOWER COVER LOW WHITE	1 Pcs	
125	8073707	Proection Plate	1 Pcs	
125-a	8902357	Screw	4 Pcs	
133	8051957	Slide foot 02 DW	3 Pcs	
134	8058491-77	Door Spring 05/06 for 07 lbs	2 Pcs	
135	8073774	Cord Set	1 Pcs	
136	8073781	TERMINAL BLOCK D3000 W/ RFI	1 Pcs	
136-a	8902131	Screw	1 Pcs	
140	8073825	Inl. Valve Single 120V Sens.	1 Pcs	
140-a	8052189	Hose Clamp Squeeze	1 Pcs	
141	8073879	Fill hose quick connect	1 Pcs	
142	8006948	Grommet	1 Pcs	
143	8074230	Rubber Hose	1 Pcs	
143-a	8052189	Hose Clamp Squeeze	2 Pcs	
154	33055088	Rubber Hose Orex	1 Pcs	
154-a	8052189	Hose Clamp Squeeze	2 Pcs	
158	8059758-0	Toe Kick White DW 05/06 US	1 Pcs	

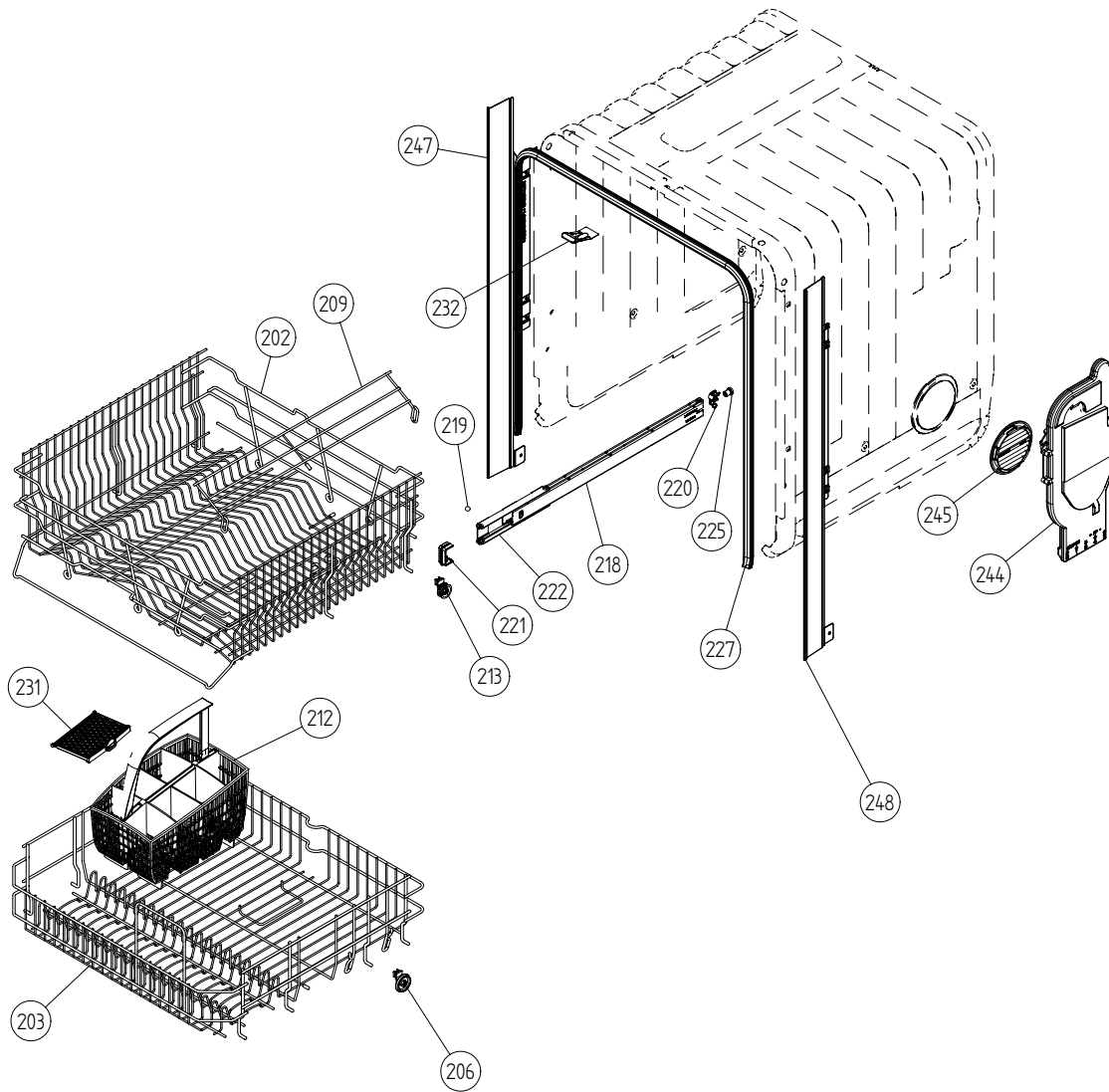

Baskets and related parts

ASKO, D3120 US - White Bi (DW20.1US)

Pos	Spare part No.	Description	Qty	Comment
201	8057056	-	1 Pcs	Not a spare part
202	8801236-36	Upper Basket Gray	1 Pcs	
203	8801237-36	Lower Basket Gray	1 Pcs	
206	8009516-77	Rack Wheels Lower 05/06 DW	8 Pcs	
209	8071336-36	Cup Shelf 05/06 DW	1 Pcs	
212	8801239-77	Cutlery Basket incl. Door	1 Pcs	
213	8058498-77	Wheel Upper Basket 05/06 DW	4 Pcs	
218	8057052	Guide Rail 05 06 DW	2 Pcs	
219	8057977	Bearing Upper Rail 05/06 DW	8 Pcs	
220	8057978-77	Rail Stop Back Grey 05/06 DW	2 Pcs	
221	8057979-77	Rack Stop Grey 05/06 DW	2 Pcs	
222	8058638-77	Ball Holder Upper Rail DW	2 Pcs	
225	8071247	Rubber Buffer Guide Rail	2 Pcs	
227	8057489	Tub Seal 05/06 DW	1 Pcs	
230	8071257	Edge Guard	1 Pcs	
231	8072986-77	Door Cutlery Basket	1 Pcs	
232	8801240	Lock Catch incl. Screw&Nut	1 Pcs	
244	8057514	Sub To 8801234	1 Pcs	
244-a	8052189	Hose Clamp Squeeze	1 Pcs	
245	8057536-77	Lockring Airbreak Gray	1 Pcs	
247	8074342-0	Trim Strip Left White	1 Pcs	
247-a	8900646	Screw 20 Torx SS	2 Pcs	
248	8074343-0	Trim Strip Right White	1 Pcs	
248-a	8900646	Screw 20 Torx SS	2 Pcs	

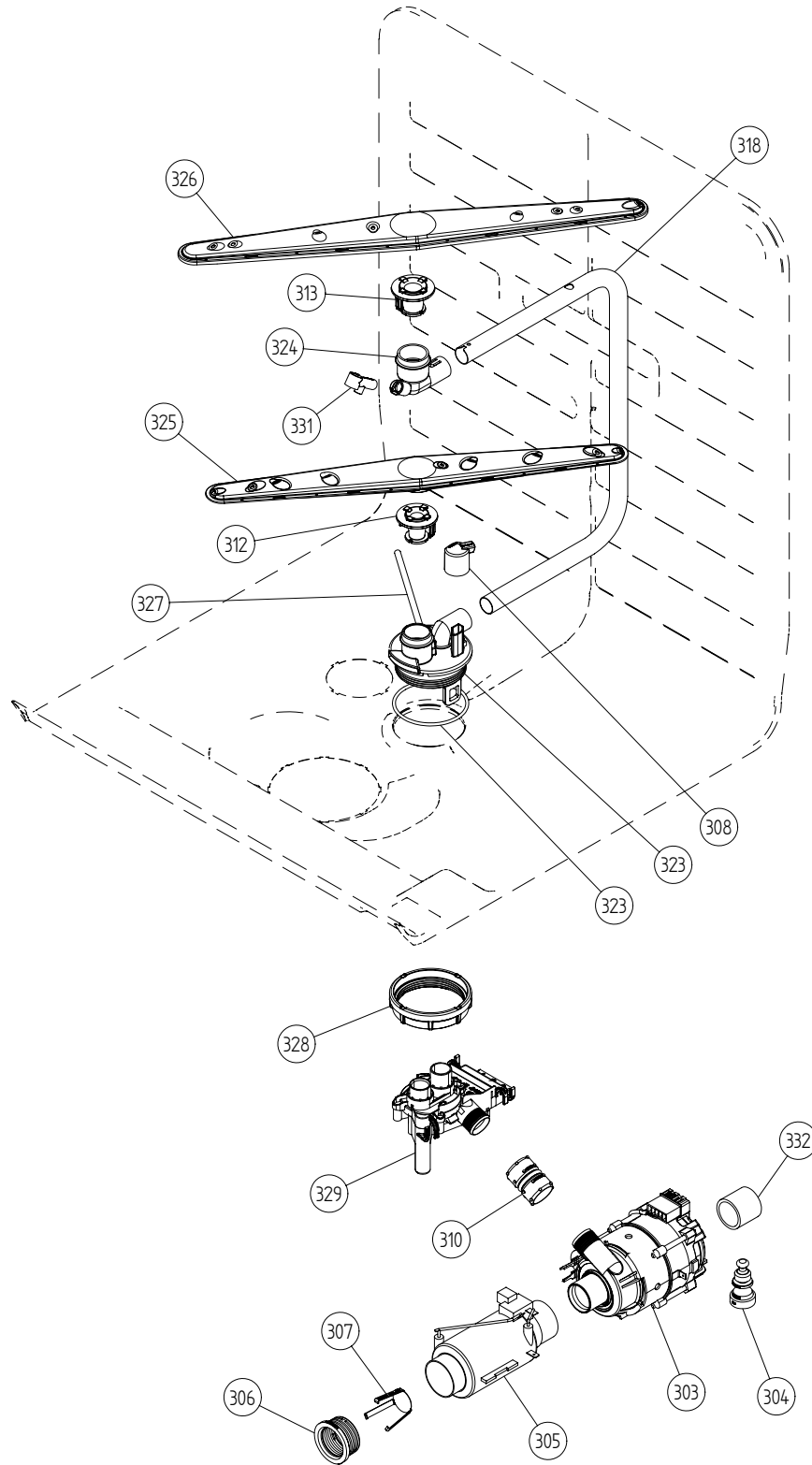

Wash system

ASKO, D3120 US - White Bi (DW20.1US)

Pos	Spare part No.	Description	Qty	Comment
301	8072108	-	1 Pcs	Not to be ordered
303	8073813	Circ. Pump 120V 60HZ	1 Pcs	
304	8075130	Rubber Damper Circ. Pump	1 Pcs	
305	8073785	Heating Element 1200W 120V	1 Pcs	
306	8073702	Element Transmutation	2 Pcs	
307	8075070	INSERT FOR HEATER	1 Pcs	
308	8073385-77	Cup Drainage Gray	1 Pcs	
310	8072888	Hose Circ. Pump	1 Pcs	
310-a	8056491	Hose Clamp Squeeze	2 Pcs	
312	8072728-77	Spray Arm Bearing L. Gray	1 Pcs	
313	8072731-77	Spray Arm Bearing Upper	1 Pcs	
318	8073387	Spray Pipe	1 Pcs	
323	8071606-L-77	Spray Tower L. Spray Nozzle	1 Pcs	
323-a	8901765	ORing det. Comp. 03/04 DW	1 Pcs	
324	8072730-L-77	Spray Tower U. Spray Nozzle	1 Pcs	
325	8072891	Spray Arm Lower Complete	1 Pcs	
326	8072894	Spray Arm Upper Complete	1 Pcs	
327	8073381	Tube Pot Rinse	1 Pcs	
327-a	8902085	Screw 20T for Plastic	2 Pcs	
328	8071607	Lockring Spray Pipe Bearing	1 Pcs	
329	8073823	INTERMEDIATE	1 Pcs	
329-a	8075071	ORing	2 Pcs	
331	8072543-77	Spray Nozzle	2 Pcs	For part no 8073381 and 8072730-L-77
332	8075420	Hose	1 Pcs	
332-a	8052189	Hose Clamp Squeeze	2 Pcs	

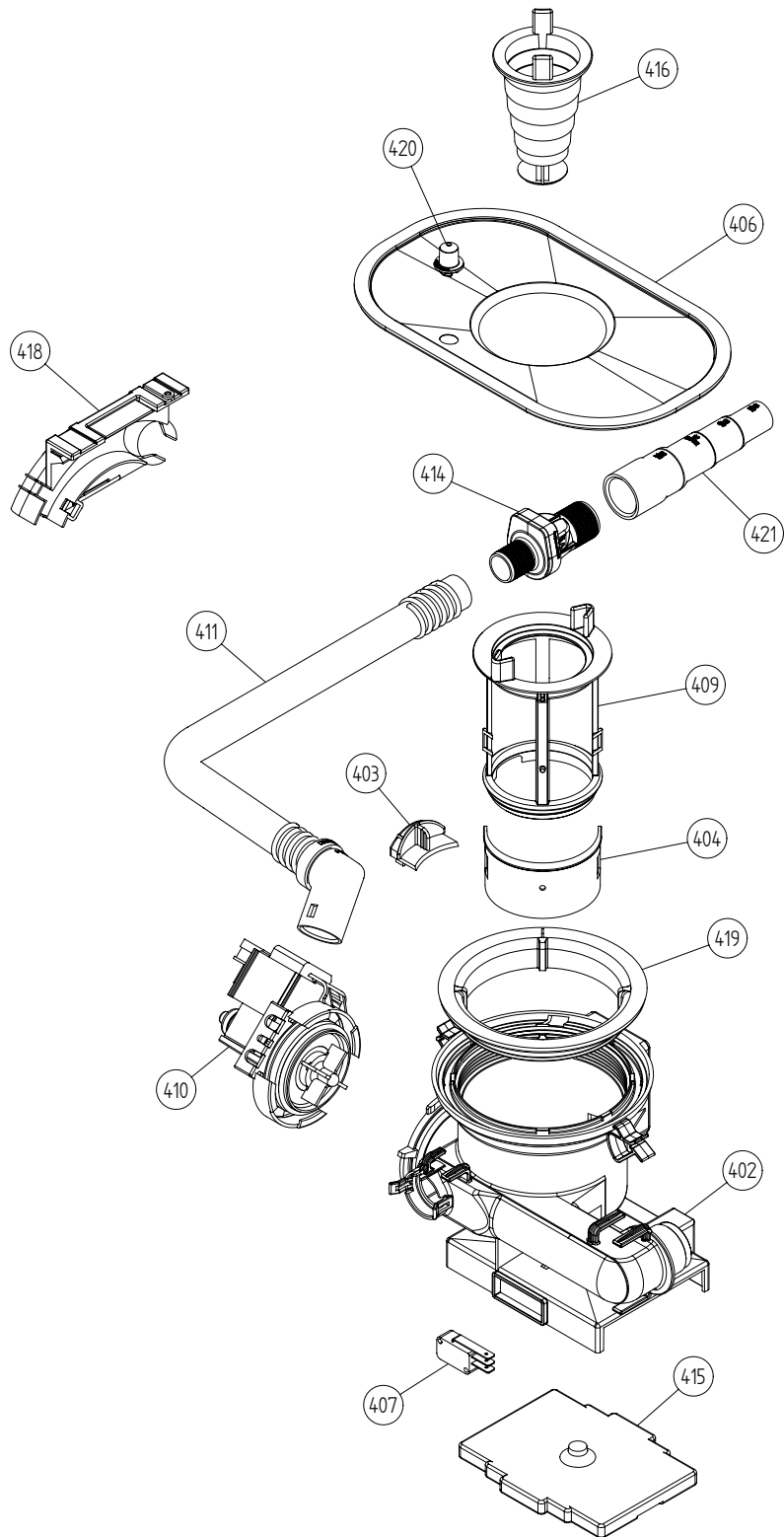

Bottom well and related parts

ASKO, D3120 US - White Bi (DW20.1US)

Pos	Spare part No.	Description	Qty	Comment
402	8073690-77	Bottom Well w/o Sensor	1 Pcs	
402-a	8073002	ORing	1 Pcs	
403	8057487-79	Sump Plug DW 05/06 Cleanout	1 Pcs	
404	8058454	Cover Str. Basket 05/06 DW	1 Pcs	
406	8074252	Use 8074364	1 Pcs	
406	8074364	STRAINER DW20	1 Pcs	
407	8073835	MICROSWITCH FLOAT	1 Pcs	
409	8073396-77	INSERT STRAINER BASKET	1 Pcs	
410	8073818	Drain Pump	1 Pcs	
410-a	8002584	ORing Drain Pump 05/06 DW	1 Pcs	
411	8074030	Outlet Hose	1 Pcs	
411-a	8052239	Hose Clamp Squeeze	1 Pcs	
411-b	8052430	Cable Strip	1 Pcs	
414	8073403	NON RETURN VALVE	1 Pcs	
414-a	8052239	Hose Clamp Squeeze	1 Pcs	
414-b	8053642	Hose Clip	1 Pcs	
415	8075110	FLOAT	1 Pcs	
416	8057972-77	Strainer Basket Grey 05/06 DW	1 Pcs	
418	8072528-77	Holder Outlet Hose	1 Pcs	
418-a	8053642	Hose Clip	1 Pcs	
418-b	8052239	Hose Clamp Squeeze	1 Pcs	
418-c	33700450	Cable Strip	1 Pcs	
418-d	8902072	Screw	1 Pcs	
419	8072848	Lockring Bottom Well	1 Pcs	
420	8074760-77	Ventilator	1 Pcs	
421	8075321	End Cuff	1 Pcs	

S:\UDW2011_Tryckunderlag\Kopplingsschema\8073809 Circuit diagram DW20.4_c.dft , mail , 2002-06-18 08:34:08

This document must not be copied without our written permission, and the contents thereof must not be imparted to a third party without the prior written consent and purpose. Askö Cylinda AB

CD: COMBI DISPENSER
 CP: CIRCULATION PUMP
 DIV: WATER DIVERTER VALVE
 DP: DRAIN PUMP
 DR: DOOR
 DS: DOOR SWITCH
 F: FILTER
 FM: FLOW METER
 FN: FAN
 FS: FLOAT SWITCH
 HE: HEATING ELEMENT
 HL: HALOGEN LAMP
 HS: HUMIDITY SENSOR
 IS: ILLUM. SWITCH
 IV: INLET VALVE
 MS: MAIN SWITCH
 PS: PRESSURE SENSOR
 RAS: RINSE AID SENSOR
 SS: SALT SENSOR
 SV: SALT VALVE
 TH: THERMISTOR
 TS: TURBIDITY SENSOR
 VAX: VAX ACTUATOR
 NET: INTERFACE TO HOME NET COMMUNICATION UNIT

— WIRES IN ALL MACHINES
 - - - INTERNAL CONNECTION
 - · - WIRES IN SOME MACHINES

RESISTANCES AT ROOM TEMPERATURE (CA. 20°C/68°F)
VALUES WITH +/-10% ARE REGARDED AS NORMAL

COMPONENT	RESISTANCE
RADIO INTERFERENCE SUPPRESSION FILTER	1 MOHM
HEATING ELEMENT 1400W 120V	12 OHM
HEATING ELEMENT 1800W 230V	30 OHM
THERMISTOR	25 KOHM
COMBINED DISPENSER 120V	0.3 KOHM
COMBINED DISPENSER 230V	1.3 OHM
CIRCULATION PUMP 120V 60HZ	22 OHM
CIRCULATION PUMP 230V 50HZ	90 OHM
CIRCULATION PUMP 220V 60HZ	56 OHM
DRAIN PUMP 120V 60HZ	25 OHM
DRAIN PUMP 230V 50HZ	150 OHM
DRAIN PUMP 230V 60HZ	85 OHM
SPRAY ARM DIVIDER 120V 60HZ	2.6 KOHM
SPRAY ARM DIVIDER 230V 50/60HZ	8.5 KOHM
INLET VALVE SINGLE INCL. FLOW SENSOR 120V	0.95 KOHM
INLET VALVE SAFETY INCL. FLOW SENSOR 120V	0.5 KOHM
INLET VALVE WATER SOFTNER INCL. FLOW SENSOR 120V	0.95 KOHM
INLET VALVE SINGLE INCL. FLOW SENSOR 230V	3.8 KOHM
INLET VALVE SAFETY INCL. FLOW SENSOR 230V	2 KOHM
INLET VALVE WATER SOFTNER INCL. FLOW SENSOR 230V	3.8 KOHM
HALOGEN LAMP 5W 12V	<10 KOHM
WAX MOTOR	1.1 KOHM
FAN MOTOR 120V	0.18 KOHM
FAN MOTOR 230V	0.75 KOHM

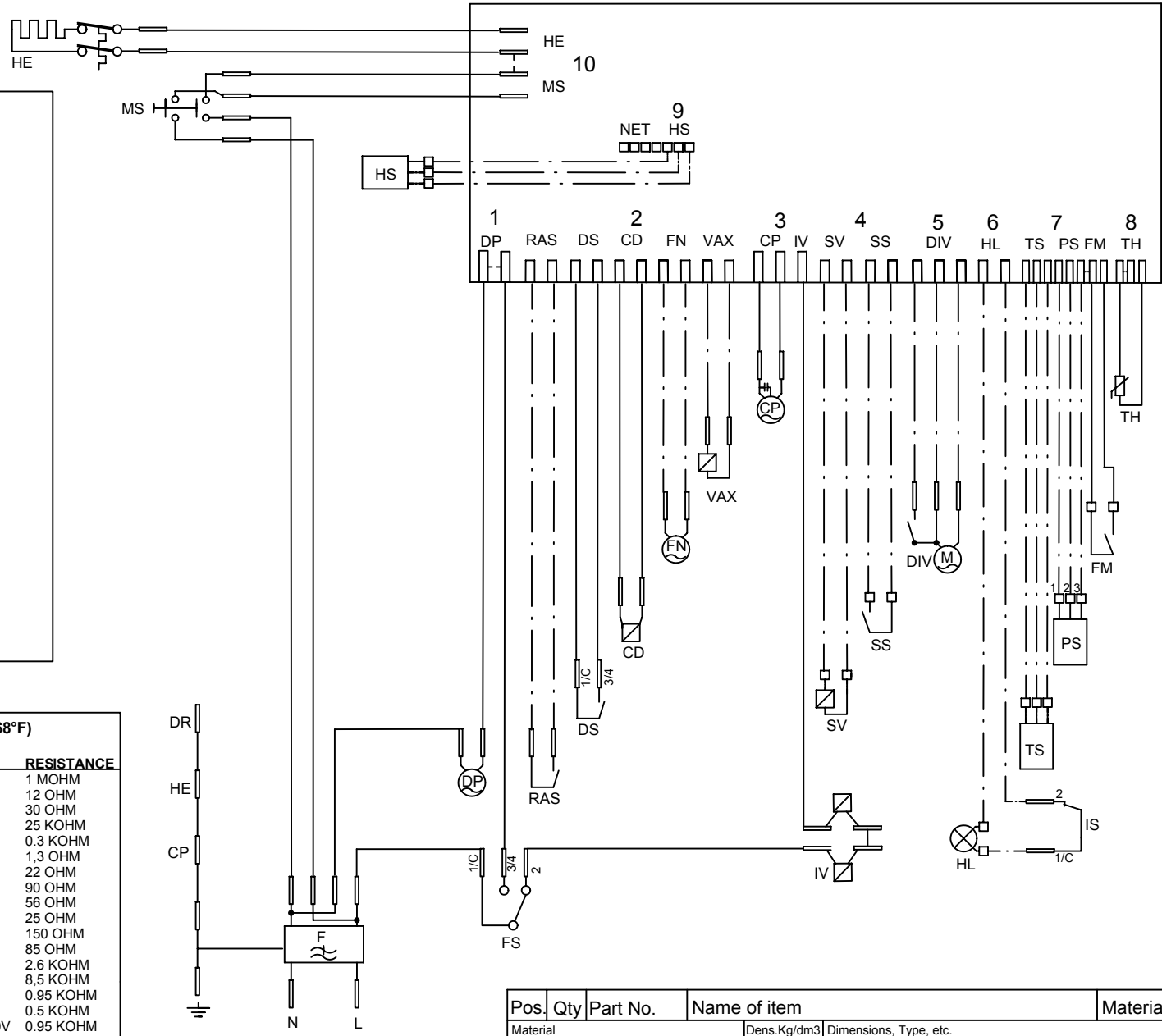

Pos.	Qty	Part No.	Name of item	Material
Material		Dens.Kg/dm3	Dimensions, Type, etc.	
Scale	1:1	Gen.tolerance	Description(ENG) CIRCUIT DIAGRAM DW20.1, .2, .3, .4, .C	
Designed by	ML	Gen.tol.Angle	Description(SE) KOPPLINGSSCHEMA DW20.1, .2, .3, .4, .C	
Released by	UD	Iss by Dept	Year	Week
			00	41
ASKO CYLINDA			80 738 09	00
			Rev Ind	Replace
				Project

Rev ind	Revision	Appd	Year	Week

Displays

DW20.1

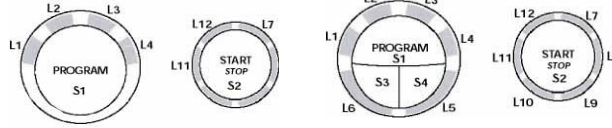

Panel type DW20.1, L = LED, S = Push-button

DW20.2



Panel type DW20.2, L - LED, S - Push-button, D - Display

DW20.3



Panel type DW20.3, L - LED, S - Push-button

DW20.4



Panel type DW20.4, L - LED, S - Push-button

TOTAL RESET

- TURN OFF MAIN SWITCH
- WAIT FOR AT LEAST 5 SECS
- HOLD PROGRAM BUTTON (S1)
- TURN ON MAIN SWITCH
- RELEASE PROGRAM BUTTON (S1)

SERVICE MENU

- TURN OFF MAIN SWITCH
- WAIT FOR AT LEAST 5 SECS
- *HOLD PROGRAM AND START BUTTONS (S1 & S2)
- TURN ON MAIN SWITCH
- RELEASE PROGRAM AND START BUTTONS (S1 & S2)
- *FOR DW20.4 HOLD TEMPERATURE/SET AND DRYING/MENU (S3 & S4)

VARIANT SETTING

- *ACTIVATE THE SERVICE MENU
- PRESS START (S2) 3 TIMES WITHIN 5 SECS
- *FOR DW20.4
- HOLD PROGRAM AND START BUTTONS (S1 & S2)
- TURN ON MAIN SWITCH
- RELEASE PROGRAM AND START BUTTONS
- PRESS START (S2) 3 TIMES WITHIN 5 SECS

COMPONENT TEST:

First enter Service menu.

DW20.1

No component test available.

DW20.2 and DW20.3

Component test:

Press the Programme button (S1) and index through the following components:

1. Inlet valve
2. Salt valve (only machines with water softener)
3. Detergent and surfactant dispenser
4. Circulation pump
5. Heating element and circulation pump (Max 75°C)
6. Fan
7. Drain pump

DW20.4

First enter service menu.

Press Drying/Menu (S4) to access component diagnostics.

Press Temperature/Set (S3) to activate the following components:

1. Inlet valve (display shows water intake volume)
2. Salt valve (only machines with water softener)
3. Detergent and surfactant dispenser
4. Circulation pump (display shows turbidity in Volts)
5. Heating element and circulation pump (Max 75°C)
6. Fan (display shows humidity sensor value)
7. Drain pump (display shows pressure sensor reading; 0.5-3.5 VDC)

Pos.	Qty	Part No.	Name of item	Material
Material		Dens.Kg/dm3	Dimensions, Type, etc.	
Scale	1:1	Gen.tolerance	Description(ENG) CIRCUIT DIAGRAM DW20.1, .2, .3, .4, .C	
Designed by	ML	Gen.tol.Angle	Description(SE) KOPPLINGSSCHEMA DW20.1, .2, .3, .4, .C	
Released by	UD	Iss by Dept	Year	Week
			00	41
ASKO CYLINDA			80 738 09	Rev Ind 00
				Replace
				Project

Rev ind	Revision	Appd	Year	Week
---------	----------	------	------	------

S:\UDw20v1_Tryckunderlag\Kopplingsschema\8073809 Circuit diagram DW20.4_c.dft . mail . 2002-06-18 08:34:08

This document must not be copied without our written permission, and the contents thereof must not be imparted to a third party without the prior written consent of Askof Cyllinda AB. This information will be processed.