

Dishwasher Training/Repair Manual

• Water valves.....	4
• Circulation pumps & impellers.....	6
• Service Tips.....	11
• Control modules.....	14
• Service Tips.....	22
• Heater assemblies & NTC's.....	23
• Service Tips.....	27
• Drain pumps.....	34
• Service Tips.....	35
• Dispensers.....	36
• Service Tips.....	39
• Cosmetic damage.....	42
• Service Tips.....	43
• Door latches.....	44
• Service Tips.....	46
• Aqua sensors.....	48
• Water fill assemblies.....	49
• Miscellaneous service tips.....	50

NOTE: Dishwashers are rated 120V, 60 Hz, 15A, 1450W (max.). Maximum amp draw when heaters running ~ 11A.

Warnings

- **⚠ WARNING** Modern appliances are very powerful and use high technology devices to safely control that power. Failure to use the correct procedures and the approved parts can create serious hazards for the person servicing the appliance and for the user of an appliance with a bad repair. **If you do not know how to service the appliance, do not attempt to do so!**
- To avoid the risk of serious injury or death while servicing these appliances:
 - Be certain that all power is removed from the appliance before beginning service.
 - Carefully follow all servicing instructions. Verify the instructions if there are any that you don't fully understand.
 - Read and heed all Cautions and Warnings on the appliance and those with the replacement parts.
 - Use caution and proper protective gear when handling chassis panels. Some of the edges that are not normally exposed may be very sharp.
- To avoid risk of serious injury or death to the users of the appliances:
 - Carefully follow all service instructions.
 - Use only parts authorized for the application.
 - Know the testing requirements needed to verify the safety of the service action.
 - Use proper, calibrated test equipment.
 - Do all indicated safety tests and record results.

Warranty Serial # Info

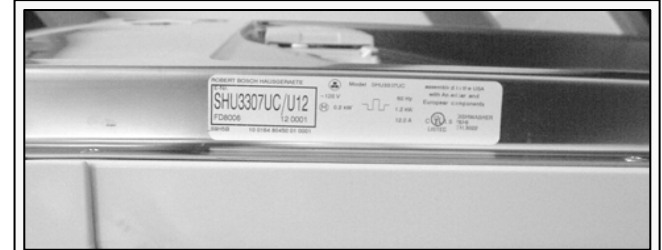
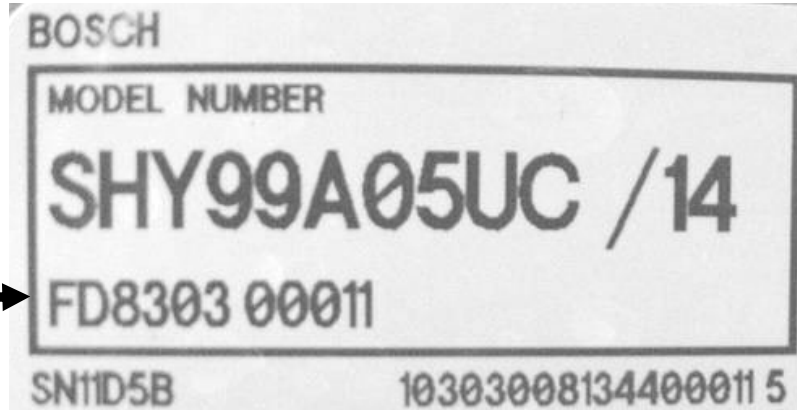

The serial label is fastened to the right edge of the inner door.

FD8303 00001

Understanding FD Serial # (used for warranty)

The FD # shows the Fabrication Date

- The first 2 #s represent the year: 83 = 2003
- The next 2 #s represent the month: 03 = March
- The next 5 #s represent the unit made that month: 00011 = 11th SHY99A05UC made that month

This helps the factory investigate product problems.

10 3 03 0081344 00011 5

Understanding Factory Serial

- The first 2 #'s represent a factory code: 10 = New Bern dishwasher, 82 = New Bern cooking
- The 3rd # represents the last digit of the year: 3 = 2003
- The next 2 #'s represent the month: 03 = March
- The next 7 #'s represent the model: 0081344 = SHY99A05UC
- The next 5 #'s represent the unit made that month: 00011 = 11th SHY99A05UC made that month
- The last # represents a check digit = 5 in this case (is dependent on all preceding #'s)

Please hold all warranty parts for (60) days for possible return for analysis.

Part # 1 -- Water Valve (1)

Disassembly

Access the water valve from the front of the dishwasher base by removing the toe kick.

To remove water valve:

Tools needed: T20 Torx screwdriver & pliers.

1. Remove two (2) T-20 Torx screws from toe kick and tilt toe kick out from under dishwasher.
2. Remove base insulation (on models with insulation).
3. Move sump inlet hose away from water valve (without disconnecting it).
4. Disconnect wires from water valve, including ground wire.
5. Remove two (2) T-20 Torx screws from water valve.
6. Pull valve out from dishwasher and disconnect water hose from rear of valve. Remove any water from sump & base.

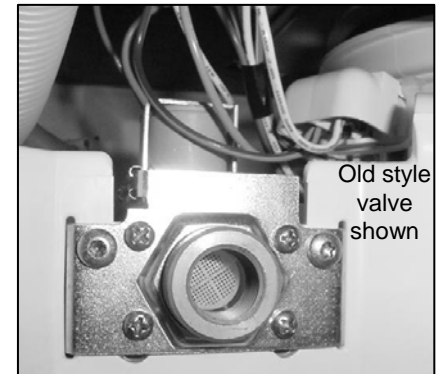

CONNECTION HINTS: Water connection 3/8" NPT female. Inlet water pressure range 5 - 120 psi (0.3 – 8.27 bars).

Removing toe kick

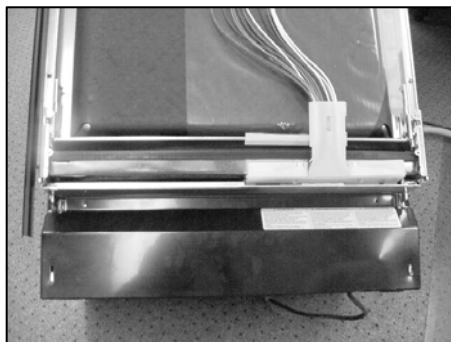

Moving sump hose

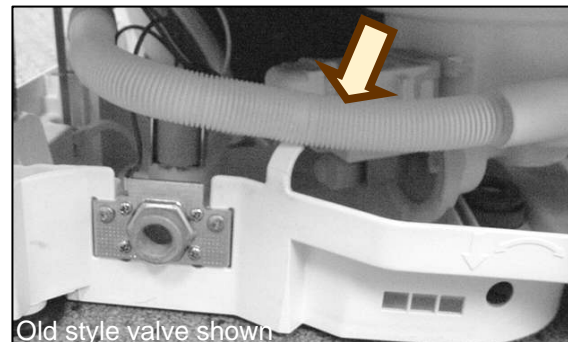

Removing hose clamp

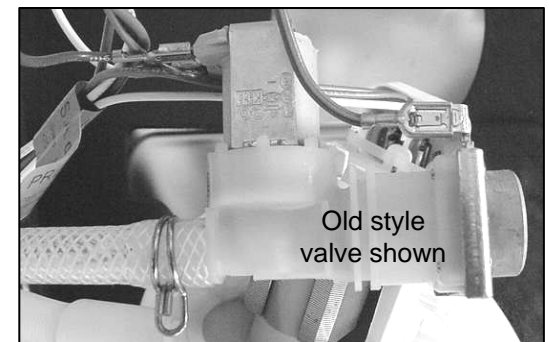

Part # 1 -- Water Valve (2)

Service Tips

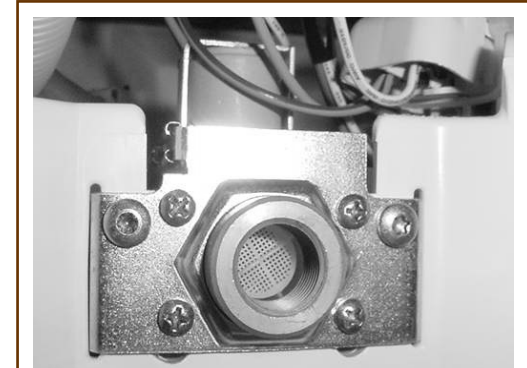

HINTS:

- When reconnecting the water supply to the water valve, don't overtighten the elbow fitting. On valves with vertical solenoids, the plastic can crack and cause leaking if excessive force is used.
- Using Teflon tape on water fittings can help prevent leaking.
- The water valve can be accessed without removing outer door or base cover. However, removing them will provide easier access.

NOTE: Water valves have been upgraded several times since 1st 1/4 of 1999.

- New time-fill valve # **425458** looks like pressure-fill valve # **189533**, but isn't the same. Don't use # **189533** to replace it.
- Use time-fill valve # **425458** to replace pressure-fill valve # **189533**.
- Current pressure-fill valve (part # **189533**) has a horizontally mounted solenoid and water fitting held in place by the metal mounting bracket. Its the only replacement pressure-fill valve available and replaces all other valves.
- Older pressure-fill valves (**580009 & 167081**) were both replaced by **189533**.

Part # 2 -- Circulation Pump & Impeller (1)

Access

The circulation pump & capacitor are accessed from the right side of the dishwasher by removing the right side panel and blocking the tank. Use same process to access heater & Apexx modules.

To remove outer door:

Tools needed: T20 Torx screwdriver.

1. Remove six T-20 Torx inner door screws below fascia panel -- three per side (1).
2. Carefully pull bottom of outer door out from dishwasher until top door tabs clear, then pull door down until it releases from dishwasher (2). Take care to not scratch outer door.
3. Remove 1-piece foam or two plastic door guards (3). The plastic door guards occasionally fall out when the outer door is removed.

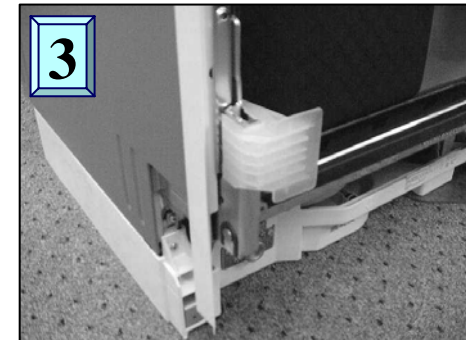

NOTE: Circulation pump 239144 motor is rated 120V, 60 Hz, 160W, insulation class A. Motor has an auto-reset thermal protector and uses a 10 μ F capacitor.

HINT: The fascia panel and door don't need to be removed to access the circulation pump. However, they must be removed to completely remove the tank.

Part # 2 -- Circulation Pump & Impeller (2)

To remove toe kick:

Tools needed: T20 Torx screwdriver.

1. Remove two T-20 Torx screws from toe kick (1).
2. Tilt toe kick out from under dishwasher (2).

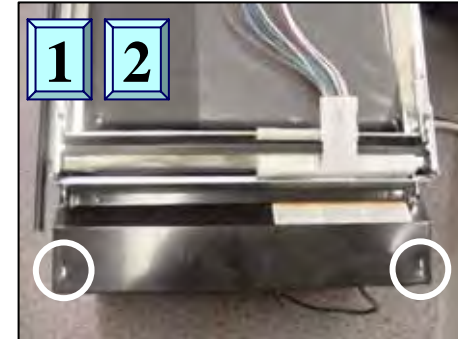

To remove right & left side panels:

Tools needed: T20 Torx screwdriver.

Dishwashers may have long or short side panels, depending on model. Removing the left side panel isn't necessary for access, but allows the right side of the tank to be blocked upward.

1. For models with long side panels, remove two T-20 Torx side panel screws through holes in right & left trim strips (1).
2. To remove long side panels, lift panels with trim strips up and out from dishwasher (2).
3. To remove short side panels, remove two T-20 Torx screws (3). To avoid damaging trim strips (while blocking tanks), slide trim strips up until they clear dishwasher bases.



Part # 2 -- Circulation Pump & Impeller (3)

To raise right side of tank for circulation pump access:

Tools needed: T20 Torx screwdriver and pliers.

1. Remove one T-20 Torx screw from both rear corners holding tank to base (1) -- removing screw from both sides allows tank to be blocked upward.
2. Remove right toe kick bracket by removing T-20 Torx screw (2).
3. Remove T-20 Torx screws from front right bottom corner holding tank to base (3).
4. Remove right hinge cover (4a), release right door tension cord from hinge (4b) & remove ground wire (4c).
5. Raise and block up tank as shown with strut onto base (5a), sliding a piece of wood or other solid material between the tank and base to keep tank from falling back onto base (5b).

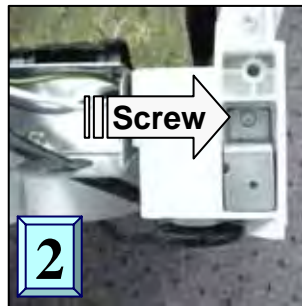

CAUTION: Don't turn dishwashers upside-down for tank access. When dishwashers are turned upside-down, water can flow into the water fill assembly diaphragm and cause water to not fill properly.



Part # 2 -- Circulation Pump & Impeller (4)

Disassembly

To remove motor to access impeller or change complete pump:

Tools needed: flat blade screwdriver.

1. Disconnect wire harness from motor after carefully noting connections (1).
2. For UC/11 & later models with softer bearing, lift up rubber straps from both sides of motor (2). For older models, lift motor up from base.
3. To release plastic latch on pump/motor housing (@ 2:30 position), carefully push onto latch with screwdriver (3).
4. To release motor from pump housing, twist motor to the right (clockwise). Some force may be required. Capacitor should be ~ 11:00 position (4). Pull motor out from pump housing.

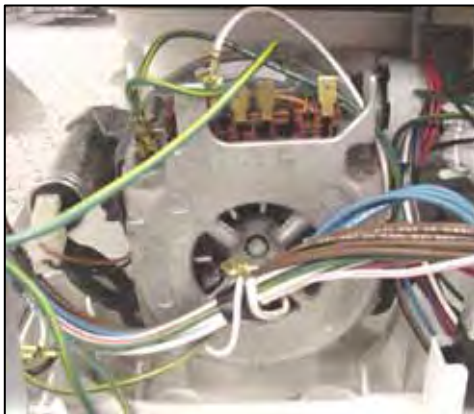

HINT: When replacing circulation pumps for softer bearing models (UC/11 & later), reusing existing front pump housings can save time by not changing hose clamps. If desired, order # **172272** hose clamps & replace entire pumps.

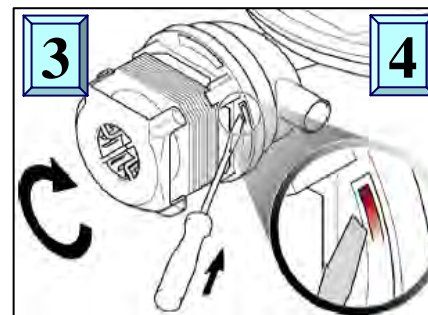
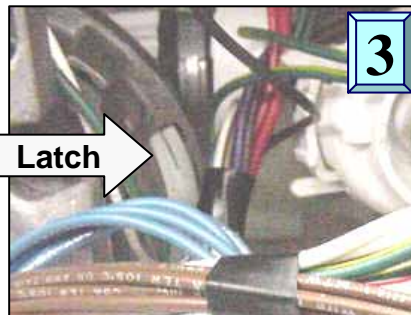
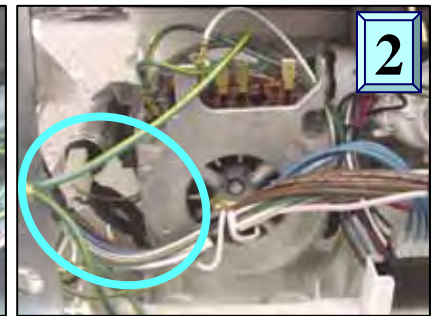

CAUTION: Don't grab motor next to the capacitor to avoid jamming your hand on the capacitor.

See page 11 for pump types.

Part # 2 -- Circulation Pump & Impeller (5)

Reassembly

To remove & install impeller (using kit # 167085):

Tools needed: flat blade screwdriver.

1. While holding motor fan so shaft won't spin (1a), unscrew impeller counterclockwise (1b).
2. Rotate pump housing counterclockwise until tabs clear, then lift housing from motor (2).
3. Remove spring and O-ring from pump housing, then lift spacer up from motor shaft (3).
4. Place replacement spacer onto motor shaft (4). Note larger end goes onto shaft 1st.
5. Install replacement spring & O-ring onto pump housing, then line up housing-motor tabs to screw pump housing onto motor (5a). Screw replacement impeller onto motor shaft (5b).
6. Align motor to pump housing with capacitor @ 11:00 position to facilitate reassembly.

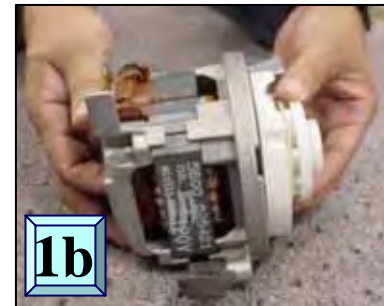

Service Tips -- Comparing Circulation Pump Versions

Depending on features, dishwashers have one of four types of circulation pumps. Pumps use different controls, wire harnesses, heaters & sump filters, so replace with identical replacement pumps.



665510 BLDC pump

- Pump, motor and control come as one unit.
- Speed changes as needed for wash cycle and washability (*Vario wash*).
- Pump is isolated from motor, so no seal is needed and no need to loosen or replace impellers
- Used starting with UC/46 index.



239144 pump

- Can buy # 266511 motor separately.
- Can use # 167085 impeller kit.



442548 ("Sicasym") pump

- Most common pump. Used starting with UC/21 index. Smaller than 239144 pump.
- Used with control modules & single wire harnesses designed for Sicasym pumps. Controls have motor starter software.
- Can't use # 167085 impeller kit.



437345 pump for water switches

- More powerful for use with water switches (Apexx & ExactWash models).
- Has separate motor starter (# 182318).
- Must use with heaters with water switches & sumps with extra filter cylinder.
- Can use # 167085 impeller kit.

Service Tips -- Checking (PTC) Pump Motor Starter

The (PTC) circulation pump motor starter (# **182318**) is used on “Apexx” and “ExactWash” models with water switches. The matching circulation pump (# **437345**) has three smaller & more efficient windings compared to the traditional pump with two larger windings (# **266511** motor / # **239144** pump). The 3rd (start) winding cuts out after the motor starts. This stronger pump is needed due to the increased water flow resistance from the water switch. Pump # **437345** includes starter # **182318**.

TECH TIPS: Resistance measurements between terminals 1 - 2 is ~ 7Ω (one of the main run windings).

NOTE: Install starter with terminal pointing inward.

HINT: (PTC) motor starter is located on top of the pump motor.

To install (PTC) motor starters, push female terminals over pump motor terminals 2 & 4. The terminals are different sizes to match the smaller motor terminal 4.

The (PTC) motor starter helps start the circulation pump. This ceramic thermal switch conducts current & heats up, cutting out the 3rd (start) winding at a preset temperature. The two main windings (with the start/run capacitor) have power whenever the pump is running.

- Check the motor starter if the pump motor won't start (starter stuck open) or runs hot (starter stuck closed).

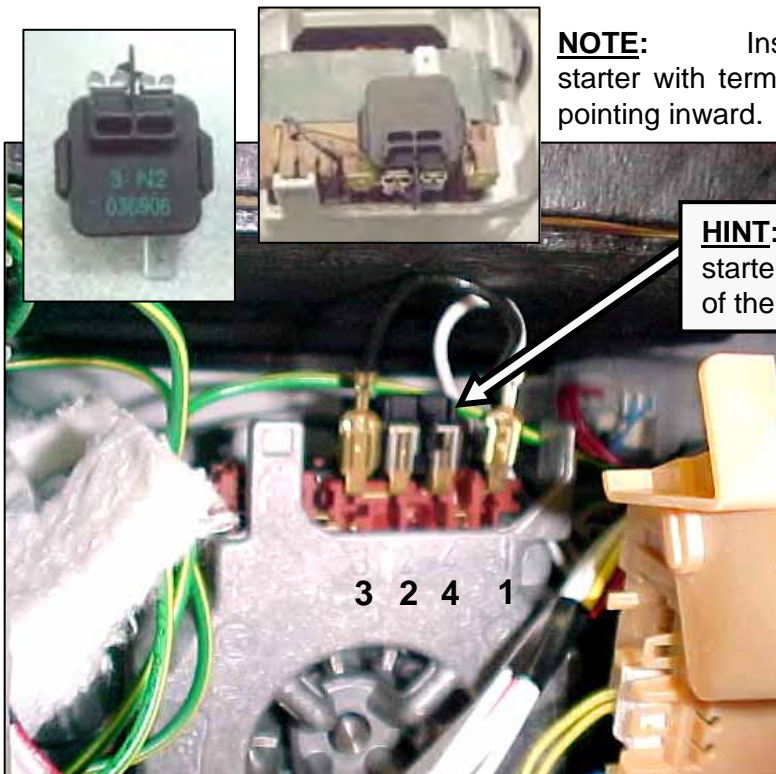

Service Tips -- Impeller Troubleshooting

Symptom	Problem	Solution
Impeller won't turn.	Impeller is frozen.	Replace impeller with impeller kit # 167085 . If not able to replace impeller immediately, place 8mm nutdriver on 8mm stud on impeller and rotate clockwise twice until impeller is freed up (for temporary fix until impeller can be replaced).
Impeller won't turn.	Debris binding pump.	Open sump & remove sump pump cover, then carefully remove debris from impeller. Check for broken glass to avoid being cut.
Impeller won't turn.	Motor is faulty.	Check resistance at motor terminals or at control panel (~ 7Ω with water switch or 10Ω without). Replace motor if faulty.

NOTE: Use 167085 impeller kit and resistances shown with 266511 motor, 239144 pump and 437345 pump. Don't use with 437345 Sicasym pump.

WARNING! Unplug dishwasher before starting any repairs.

Part # 3 -- Control Module (1)

Disassembly

(SHU 9922 shown)

Control modules are easily removed from fascia panels by bending console tabs.

Tools needed: T-20 Torx & flat blade screwdrivers.

1. Remove fascia panel by removing T-20 Torx inner door screws.
2. Disconnect wire harnesses from module after noting connector locations.
3. Pry out metal console tabs holding module to console.
4. Carefully pry back plastic tabs, then slide module from console.

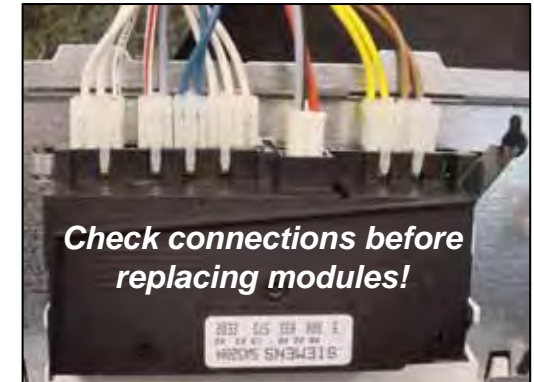

Check connections before replacing modules!



Removing door screws



Removing fascia panel



Viewing control module



Disconnecting wires



Bending back tabs



Sliding module out

TIP: Modules have been replaced when problem was loose connections. Before replacing modules, check connections first!

NOTE: Control modules for non-integrated models look differently and have different tabs, but are removed using the same procedure.

Part # 3 -- Control Module (2)

Disassembly

(SHU 995x shown)

SL95A, SHY56A/66C, SHU 995x & SHV 68 control modules are removed differently than other modules.

Tools needed: T-20 Torx & flat blade screwdrivers.

1. Remove fascia panel by removing six (6) T-20 Torx inner door screws.
2. Disconnect wire harnesses from module after noting connector locations.
3. Remove fascia panel from console by removing four (4) T-20 Torx screws.
4. Remove two (2) T-20 Torx screws holding module to console.
5. Carefully pry back locking tabs on each front corner of module, then remove module from console. Remove button pad from module.



Removing door screws



Removing fascia screws



Removing module screws



Prying back module tabs



Sliding module out



Removing button pad -- buttons can come off pad

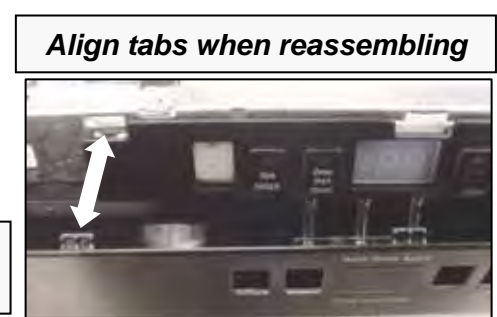

Align tabs when reassembling

Part # 3 – Control Modules with Displays

Disassembly

SHY66C control modules have separate 3-digit display modules (# 489021) mounted on the front of fascia panels.

Tools needed: T-20 Torx & flat blade screwdrivers.

To remove/install display module:

1. Remove outer door & fascia panel.
2. Disconnect wire harness, then rotate display out from pushbutton carrier.
3. Confirm the (4) pushbutton carrier display latches are intact.
4. Route display wire harness through (door latch) console opening, press harness onto pushbutton carrier wire guide & connect terminal.
5. Insert display into top latches (on pushbutton carrier), then push bottom of display up and rotate it into bottom latches.



These instructions apply only to SHY66C models.

wire guide



Removing door & fascia

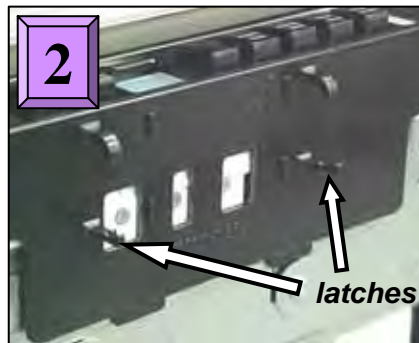

Checking display latches

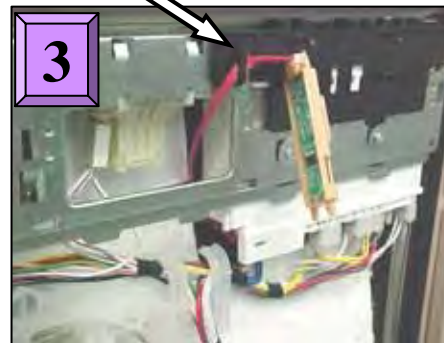

Connecting wire harness

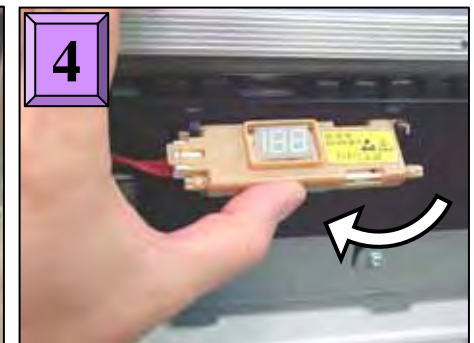

Locking display in place

Part # 3 – Apexx Control Modules (1)

Disassembly



These instructions apply to SHV/SHX/SHY99A models.

HINT: Apexx control modules cannot be checked or have resistances measured from the front of dishwashers.

NOTE: Modules were moved to the base to make room for the larger full text displays in the fascia panel.

Apexx (SHV99A/SHX99A-B/SHY99A, DWHD94) control modules are different than other models and are removed differently. Modules are mounted on the **base** (where base wiring connectors were), not behind fascia panels. This means:

- ***Dishwashers must be pulled out to change control modules.***
- ***Dishwashers must be pulled out to measure voltages & resistances.***

For access to Apexx control modules:

Tools needed: T-20 Torx screwdriver & pliers.

- 1. Remove outer door*** – see page 6.
- 2. Remove toe kick*** – see page 7.
- 3. Remove right/left side panels*** – see page 7.
- 4. Raise right side of tank*** – see page 8.

HINT: Its helpful, but not necessary, to remove outer doors to access Apexx control modules.

HINT: It may be possible to reach behind modules without blocking up tanks. If not, then follow these instructions to block up tanks.

Part # 3 -- Apexx Control Modules (2)



1 *Locating module in base*

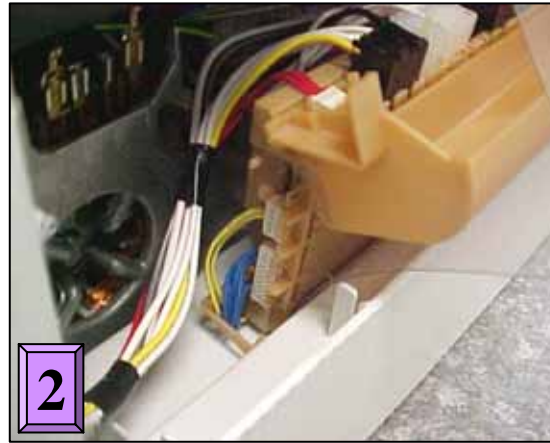

2 *Opening module cover*

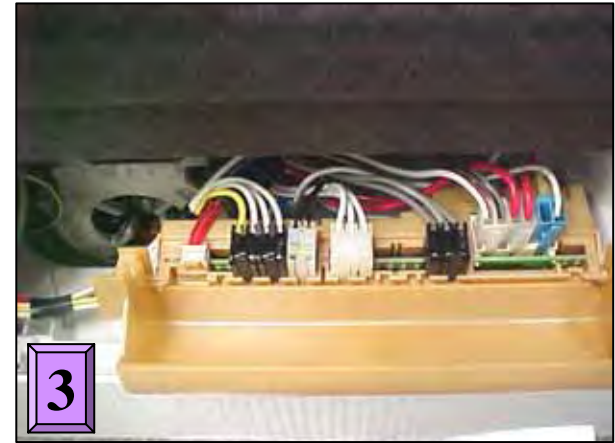

3 *Disconnecting module terminals*

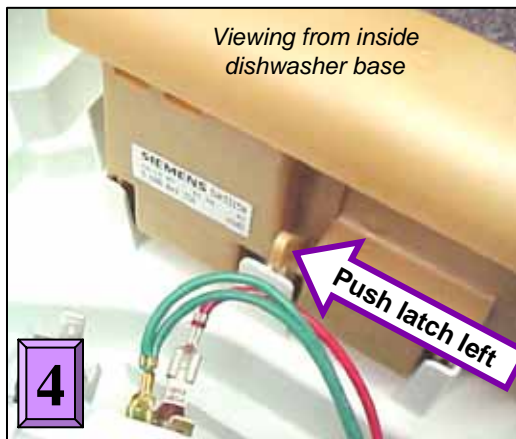

4 *Pushing back module latch*

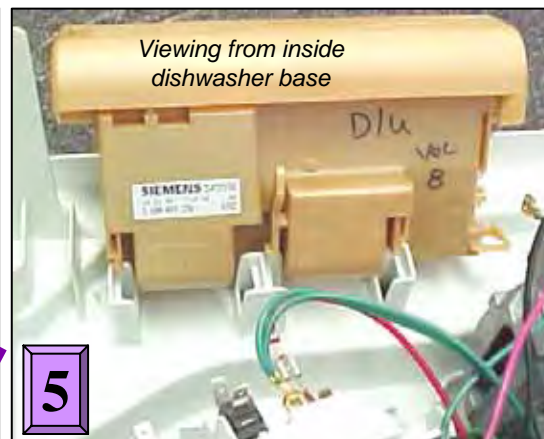

5 *Sliding module out*

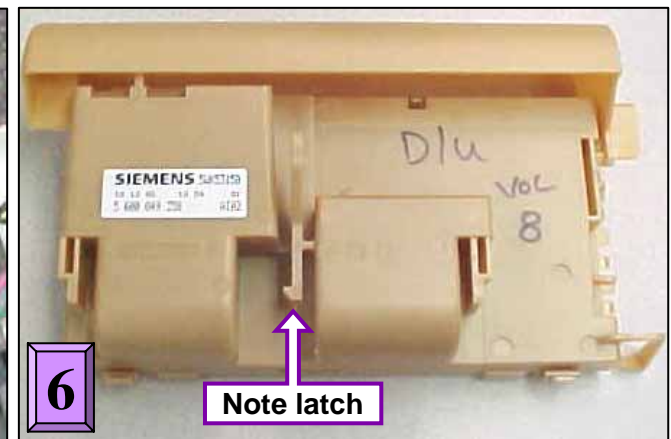

6 *Aligning module tabs when reassembling*

Part # 3 – Apexx Display Modules

Disassembly

Apexx (SHV99A, SHX99A-B, SHY99A & DWHD94) display modules are mounted on fascia panels (where control modules are mounted on other models).



These instructions apply to SHV99A, SHX99A-B, SHY99A & DWHD94 models.

NOTE: Control modules were moved to the base to make room for full text displays in the fascia panel.

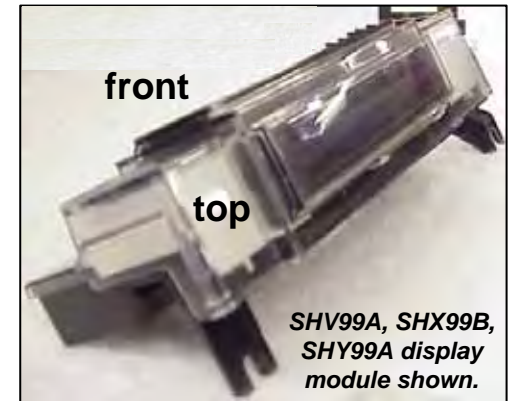

Removing fascia screws



Removing wire harness



Removing display module

Part # 3 – Control Modules with Knobs (1)

Disassembly

SHU43E/53E/66E models are operated by a single knob instead of a row of buttons. Fascia panels snap onto consoles with four plastic latches. Control modules are held into consoles by four plastic tabs.



These instructions apply to SHU43E/53E/66E models.

HINT: Knobs are an integral part of fascia panels. Remove modules from knobs, not knobs from panels.



1

Removing fascia screws



2 middle latches
& 2 side latches

2

Unlatching fascia from console

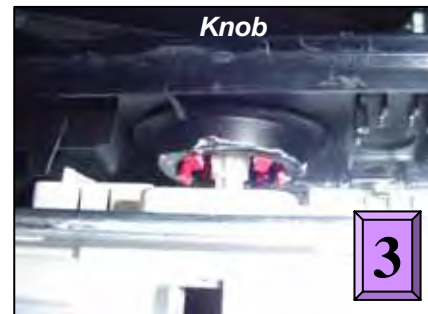

Knob

3

Removing fascia from module

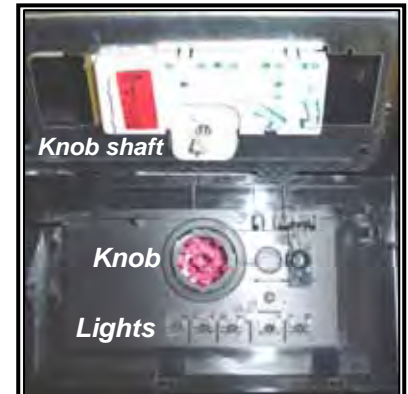

Knob shaft

Knob

Lights

Inside of fascia panel and front of control module showing knob shaft & rear of knob

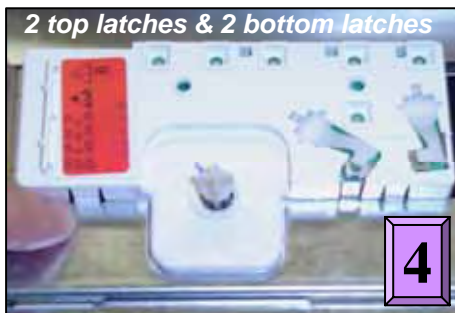

2 top latches & 2 bottom latches

4

Unlatching module from console

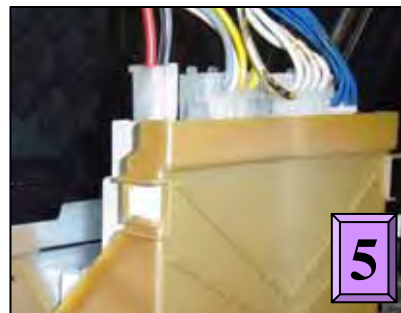

5

Removing wire harnesses

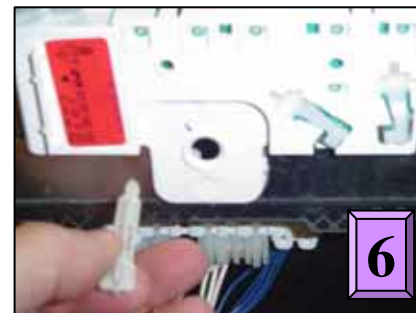

6

Removing knob shaft

TIP: Short end of "cross" on shaft lines up with knob pointer

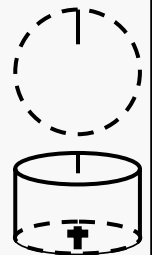

Part # 3 – Control Modules with Knobs (2)

Reassembly

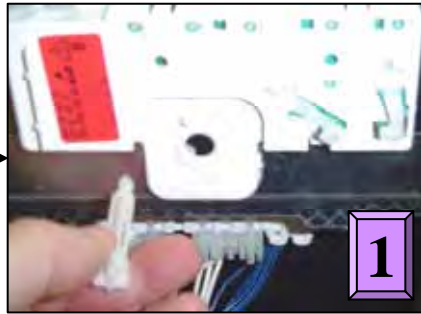

1

Inserting knob shaft into module

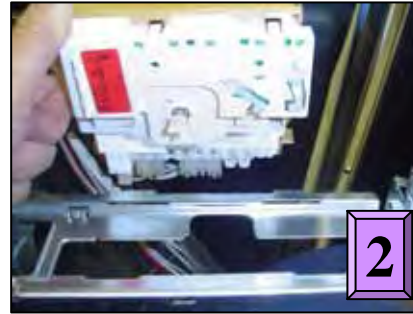

2

Snapping module into console



3

Snapping fascia onto console

Make sure short end of “cross” on shaft points (↑) up when module is right-side-up



CAUTION: Knob shafts can be inserted into modules in any of four positions (with short side of shaft “cross” up, left, right or down). Make sure shaft is inserted correctly or else wash programs won’t match fascia panels.

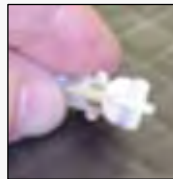

HINT: Knobs are an integral part of fascia panels. Insert the knob shaft straight into the module until it latches, then attach the module to the fascia panel (console).



HINT: Control module snaps into console only one way -- it can't be mounted upside-down.



HINT: Knob shaft fits into knob only one way – line up knob with “cross” on knob shaft before attaching fascia panel to console.



Service Tips -- Modules Displaying "1"

Occasionally dishwashers can run for hours, not finish washing & show a "1" in the display. This means the module has timed out due to an unidentified heating problem -- all heating related parts must be checked until the problem is found.

TIP: Modules have been replaced when problem was loose connections. Before replacing modules, check connections first!

IMPORTANT: Whenever a "1" shows in the module display, the module must be reset (after the heating problem has been fixed) by running the dishwasher. The module resets after the 1st run.

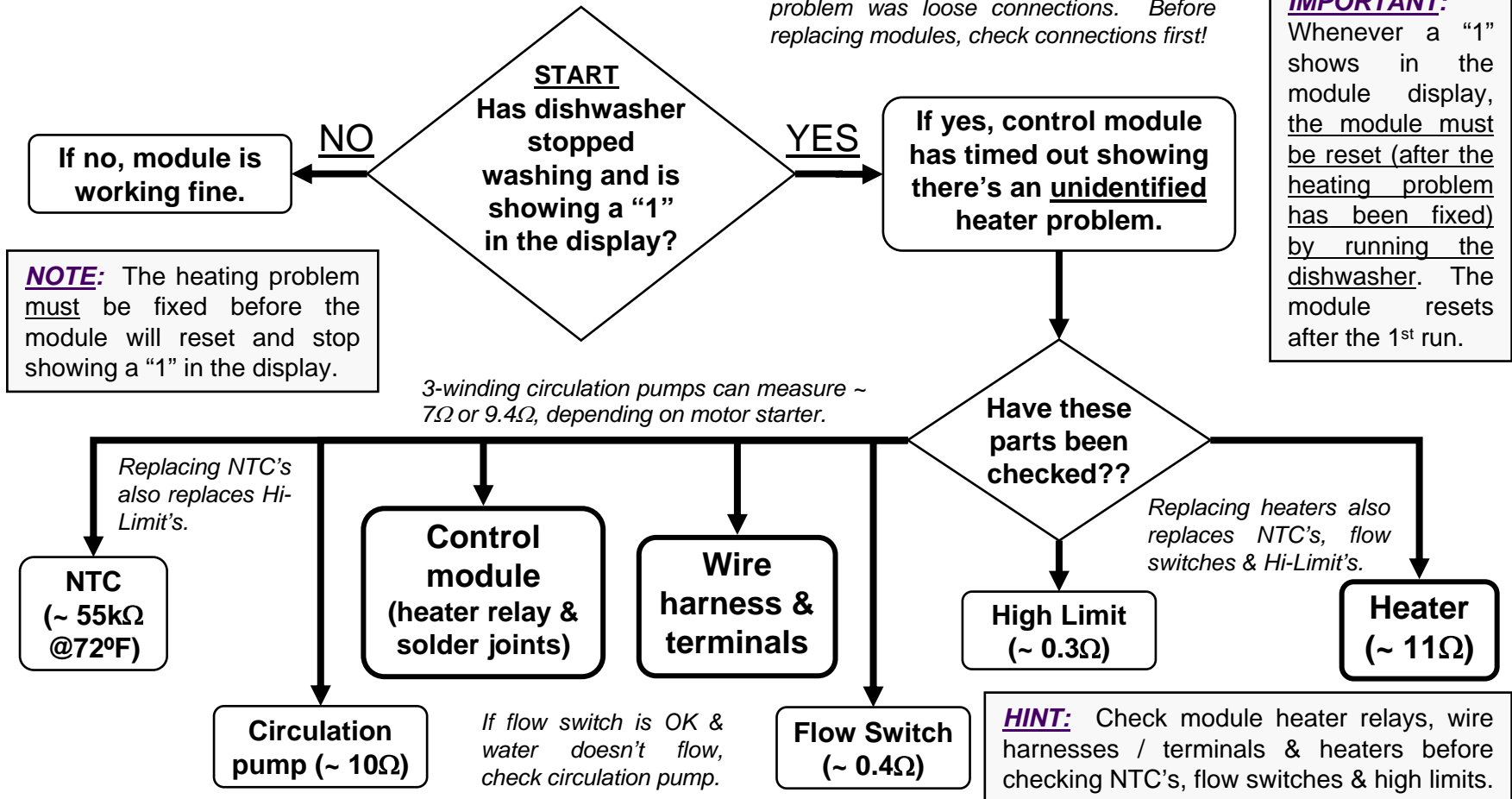

Part # 4 -- Heater & NTC (1)

Disassembly

The heater & NTC can be accessed or measured from the right side of the dishwasher, but can only be removed by dropping the entire base (by flipping the dishwasher on its back) since they are wedged underneath the tank.

For access to heaters & NTC's:

Tools needed: T-20 Torx screwdriver & pliers.

1. **Remove outer door** – see page 6.
2. **Remove toe kick** – see page 7.
3. **Remove right/left side panels** – see page 7.
4. **Raise right side of tank** – see page 8.

HINT: The fascia panel and door don't need to be removed to access the heater & NTC. However, the door must be removed to completely remove the tank.

HINT: Remove all water from the sump and hoses before accessing the heater -- when the dishwasher is flipped on its back, water can enter the water fill assembly diaphragm and cause the dishwasher to not fill properly.

To separate base from tank (1):

1. Carefully lay dishwasher on its back.
2. Carefully pull door springs out from base.



Placing on back



Pulling out door springs from base & disconnecting cords



Part # 4 -- Heater & NTC (2)

To separate base from tank (2):

3. Remove terminal blocks from base (for two-piece harnesses).
4. Disconnect hose from water valve (or remove water valve from base if easier).
5. Disconnect J-box ground wire, then pull wires out of J-box.
6. Pull out inlet hose from sump.
7. Carefully pull base away from tank and sump.

HINT: Remove water from sump and hoses before laying dishwasher on its back (to avoid water entering water fill assembly & causing faulty water filling).



Removing terminal blocks from base

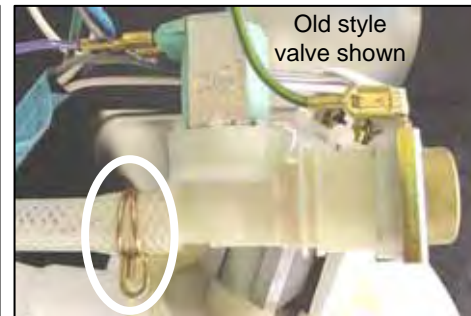

Disconnecting hose from water valve



Pulling J-box wires



Pulling out sump hose



Pulling base carefully from tank & sump



Part # 4 -- Heater & NTC (3)

To remove heater & NTC:

1. Remove two (2) T-20 Torx screws holding heater assembly to sump.
2. Disconnect wires from heater, flow switch, NTC & Hi-Limit after noting connections.
3. Pull clips, then carefully pull heater assembly from sump & pump. Note heater comes as an assembly (with housing & gasket).

NOTE: Softer bearing & non-softer bearing heater assemblies, circulation pumps and sumps **cannot** be mixed and matched. Softer bearing heaters don't fit in older models and older heaters don't fit in softer bearing models.



HINT: If needed, use rinse-aid to lubricate gaskets to make it easier to assemble heater to sump and pump.

Heater assembly Removing heater screws Removing heater from sump/pump

NOTE: Softer bearing & non-softer bearing heater assemblies are connected to circulation pumps differently:

- Softer bearing models (UC/11 & above) have gasket assembled to heater and have a separate hose clamp (order # **172272**).
- Older models (UC/06) have a separate gasket and do not have a hose clamp.

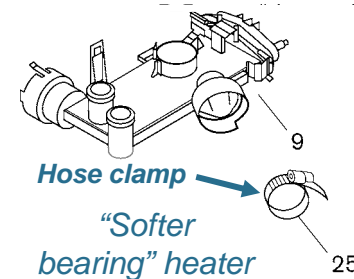

HINT: Heater assemblies contain NTC's, Hi-Limit's & flow switches (& aqua sensors where applicable). If heaters are replaced, these parts are replaced too.

Part # 4 -- Heater & NTC (4)

To remove NTC (from heater):

1. Remove heater assembly -- NTC is located on top of heater assembly.
2. Disconnect wires after noting connections (since NTC & Hi-Limit are included in the same part -- # 165281).
3. Remove NTC cover, pull NTC holding tabs apart and pull NTC out of heater.

NOTE: Softer bearing & non-softer bearing heater assemblies, circulation pumps and sumps **cannot** be mixed and matched. Softer bearing heaters don't fit in older models and older heaters don't fit in softer bearing models.



Disconnect wires



Remove cover & pull tabs



Remove NTC

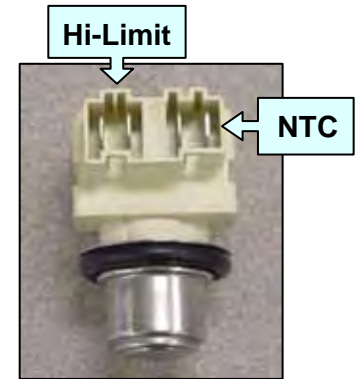

NTC w/ Hi-Limit

NOTE: To remove flow switch, carefully pry housing away from switch (until tabs clear switch), then snap switch out.



HINT: If needed, use rinse-aid to lubricate gaskets to make it easier to assemble heater to sump and pump.

HINT: Replacement parts include other parts:

- **Heater assy.** -- includes NTC, Hi-Limit, flow switch (& aqua sensor where applicable).
- **NTC** -- includes Hi-Limit.

Service Tips -- Heater Troubleshooting Flowchart

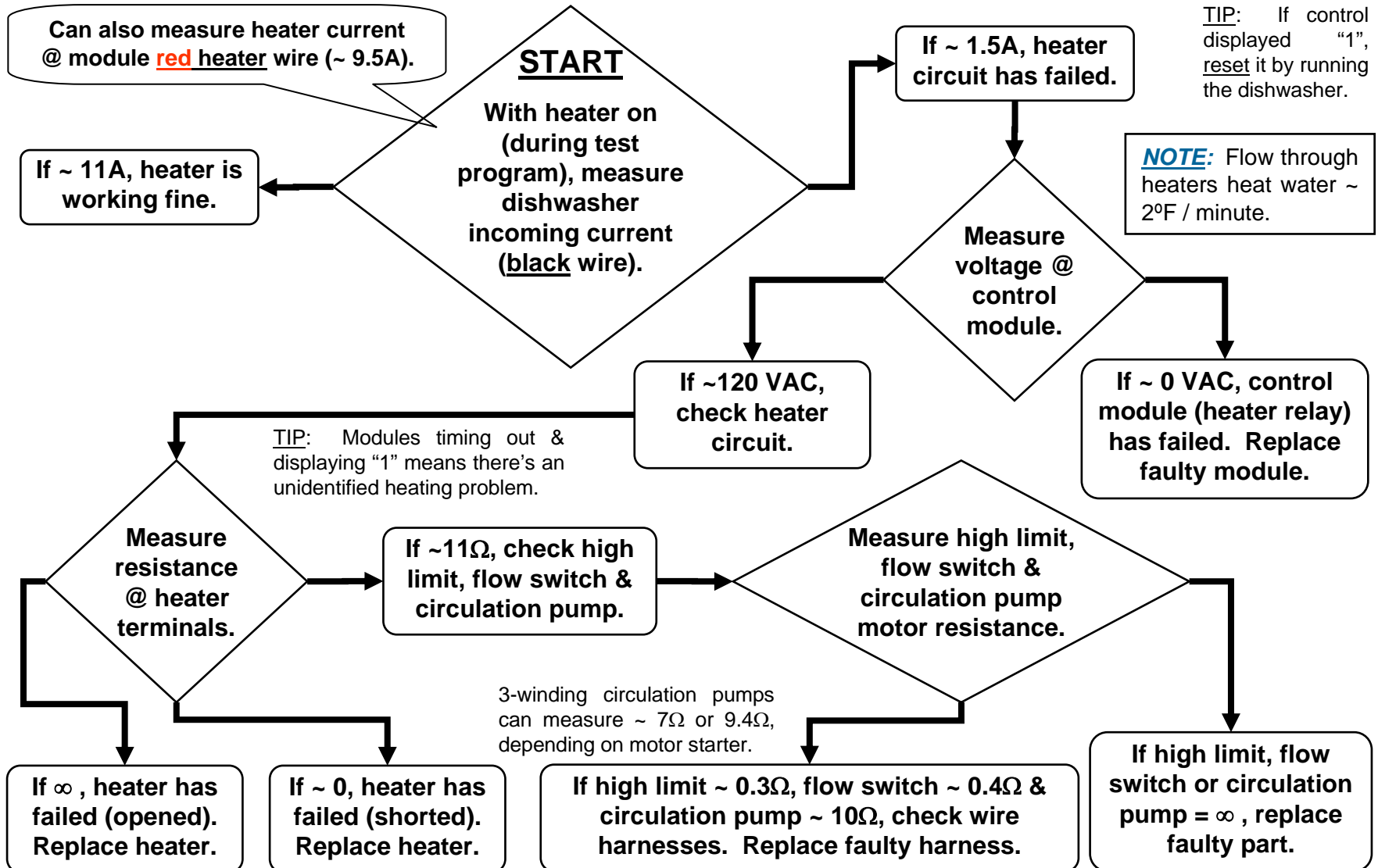

Service Tips -- Measuring Heater/NTC Resistances (1)

TEST	TIME	NOTES
Entering test program	----	Press On/Off button at <u>same time</u> Power Scrub Plus & Regular Wash buttons (SHU/I 43 models) or Scrub Wash & Delicate/Econo buttons (SHU/I 53 & 68 models) are pressed and held. Indicating lights will flash.
Starting test program	----	Press Power Scrub Plus & Regular Wash buttons (SHU/I 43 models) or Scrub Wash & Delicate/Econo buttons (SHU/I 53 & 68 models) a 2nd time.
Skipping a test	----	Press Scrub Wash button (SHU/I 43 models) or Regular Wash button (SHU/I 53 & 68 models).
Draining	30 seconds	Allow dishwasher to drain.
Aquasensor calibration	65 seconds	Not on SHU/I 43 models. Skip this test.
Filling	Until water level switch closes (pressure-fill)	Can't skip this test.
Heating & Circulation	Until water reaches 150°F (rises ~ 2°F/minute)	To save time, don't run entire test -- when water circulates, measure main current to dishwasher. If current ~ 11A, heater, flow switch & Hi-Limit are OK. If current ~ 1.5 - 2A, turn off dishwasher, block up tank and measure heater, Hi-Limit & flow switch resistances (see below).
Draining	60 seconds	Last test. To end test program, press On/Off button.

Use dishwasher test program to turn on heater, then measure dishwasher incoming current. If ~ 1.5A, heater, Hi-Limit, flow switch or circulation pump has failed. Check voltage @ module (or timer) -- if 0V, module (or timer) has failed.

For electronic models, current can also be measured through **red heater** wire at control module (~ 9.5A). Since there can be more than one **red** wire, check wiring diagram to select **heater** wire.

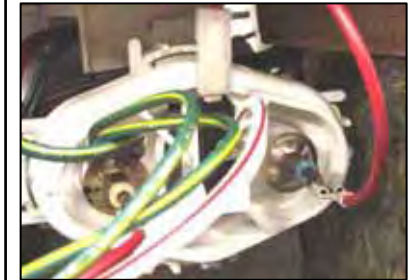

HINT: Because the flow switch only closes when water is flowing, the heater resistance can only be measured at the heater terminals (not at the control module).



HINT: The NTC and High Limit are contained in the same part. When either fails, replace entire part # **165281**.

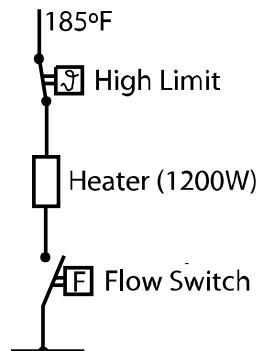

NOTE: Once it's found one of these parts is faulty (from incoming current being 1.5 – 2A), check each part (once tank has been removed or blocked up) by measuring resistance at it's terminals:

- **Heater** ~ 11 Ω
- **Hi-Limit** ~ .3 Ω
- **Flow switch** ~ .4 Ω -- must remove microswitch from heater housing and close it's contacts to measure this. A spring loaded plunger closes microswitch when water is flowing.

NOTE: Flow through heaters heat water ~ 2°F / minute.

NOTE: Open door to run test program for fully-integrated models.

Service Tips -- Measuring Heater/NTC Resistances (2)

Using test programs for various models (UC/06 - UC/17)

Models	Buttons to Enter Test Program
SHU/SHI430x, SHU431x	Power Scrub Plus + Regular Wash
SHU33/DLX	Power Scrub Plus + Rinse & Hold
SHU43C, SL34A, SHU432x	Regular Wash + Rinse & Hold
SHU53/66C/68, SHI66A/68	Scrub Wash + Delicate/Econo
SHU53A, SHX/SHY56, SL95A	Regular Wash + Quick Wash
SHU88	Power Scrub Plus + Quick Wash
SHU990x, SHV43/48	Power Scrub Plus + Regular Wash
SHU991x (thru UC/11)	Power Scrub Plus + Quick Wash
SHU991x (UC/12), SHU992x	Power Scrub Plus + Delicate/Econo
SHU995x	Regular Wash + Delicate Wash
SHV66A, SHY66A	Scrub Wash + Delicate/Econo
SHV68	Scrub Wash + Regular Wash
GI976/966, GM276	Intensive + Delicate
DW44	Heavy Wash + Light Wash

- To enter test programs, hold down buttons above (2nd & 4th from left), then turn dishwasher on by pushing on/off button. Push buttons above a 2nd time to start test program. Allow program to finish to see fault codes. Turn dishwasher off to exit test program.

HINT: Dishwasher test programs heat water to 150°F, so test programs will generally run > 20 minutes for incoming water temperatures ~ 120°F.

Using test programs for various models (UC/14 - UC/17)

Models	Buttons to Enter Test Program
SHV46C, SL84A, SHX43E/ 46A-B	Regular Wash + Delicate/Econo
SHX33A	Regular Wash + Rinse & Hold
SHU43E/53E/66E	Turn knob (see below) + Start/Stop
SHV99, SHX99, SHY99	(2) left buttons (see below)

- To enter SHV46C, SL84A, SHX33A/43E/ 46A-B test programs, hold down 2nd & 3rd from left of three test program buttons, then turn dishwasher on by pushing on/off button. When in test program, 2nd button light (Regular Wash) will be lit and 3rd button light will flash. Push 2nd button (Regular Wash) to scroll until test program is chosen -- when 3rd button light is lit (). Push 3rd button to start test program. Allow program to finish to see fault codes. Push 2nd button (Regular Wash) to skip certain steps. Turn dishwasher off to exit test program.
- To enter SHV/X/Y99 test programs, open door, hold down 2 left buttons & turn dishwasher on by pushing on/off button. Press "+" button repeatedly until "S-3-" shows on display, then push start button to check faults on last 8 washes. Close door to begin test program. Allow program to finish to see fault codes. Push "-" button to skip test steps. Turn dishwasher off to exit test program. Choose "S-6-" to clear fault codes.
- To enter SHU43E/53E/66E test programs, 1st rotate knob to 6:00 position (pointing straight down). Hold down Start/Stop button, then turn dishwasher on by pushing on/off button. Push Start/Stop button to start test program. When test program has finished, Clean light light will flash and all other lights will be lit.

Service Tips – NTC Resistance Chart

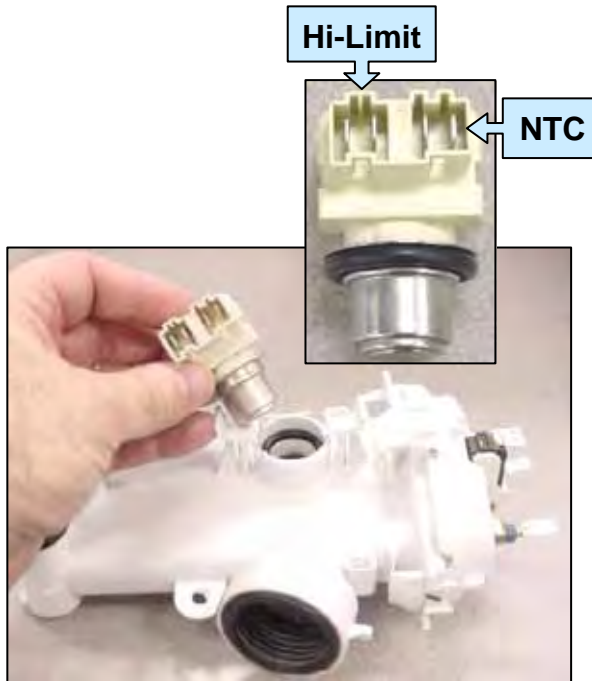

Resistance (ohms)	Temperature (°F)
55,000	72
48,409	77
16,542	122
11,067	140
9,859	145
3,713	194
2,665	212

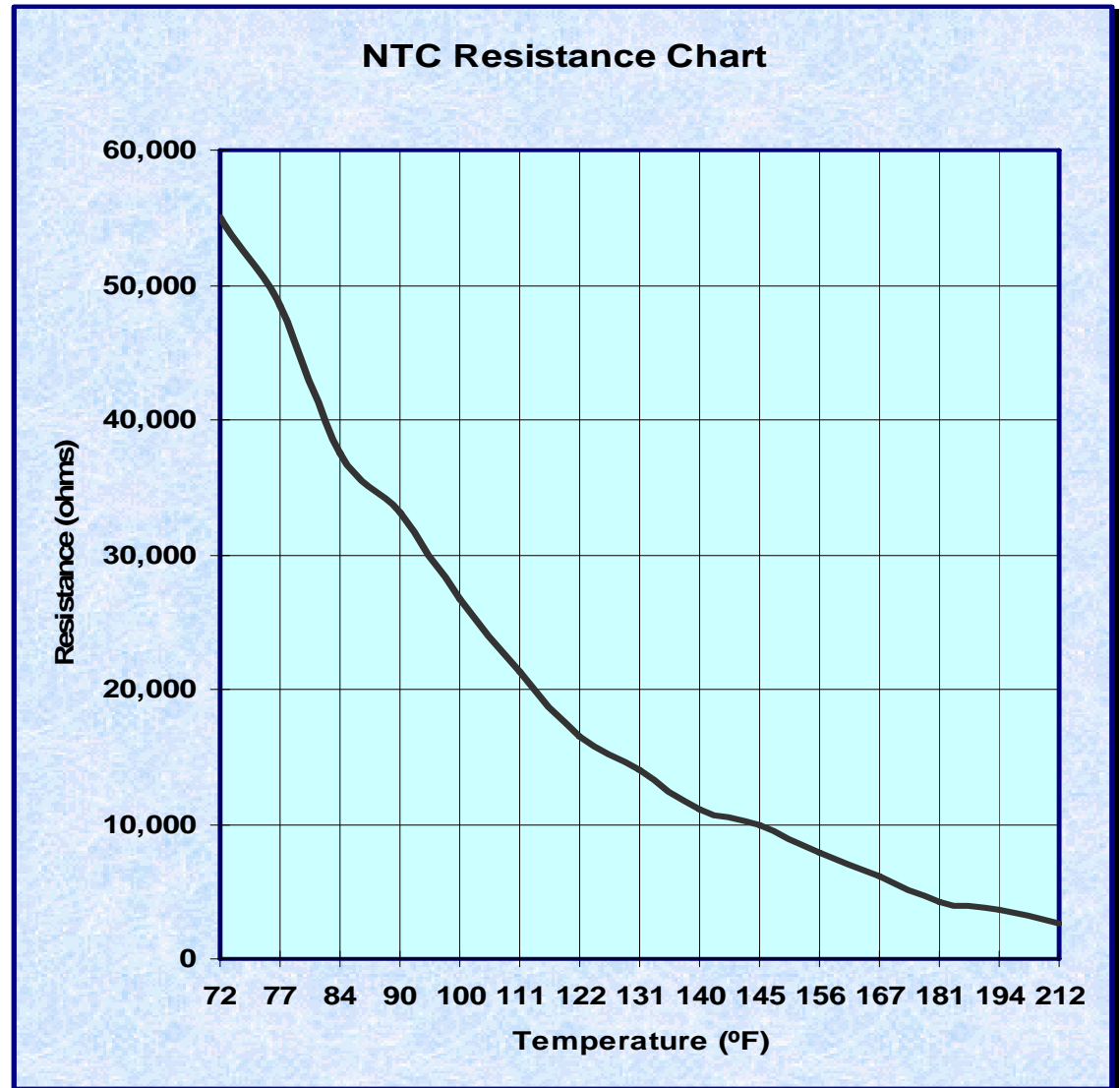

Service Tips – Heater Operation

Flow through heater heats water without an exposed tank element. Filtered water enters the heater from the circulation pump. The heater heats water when the flow switch signals water is present.

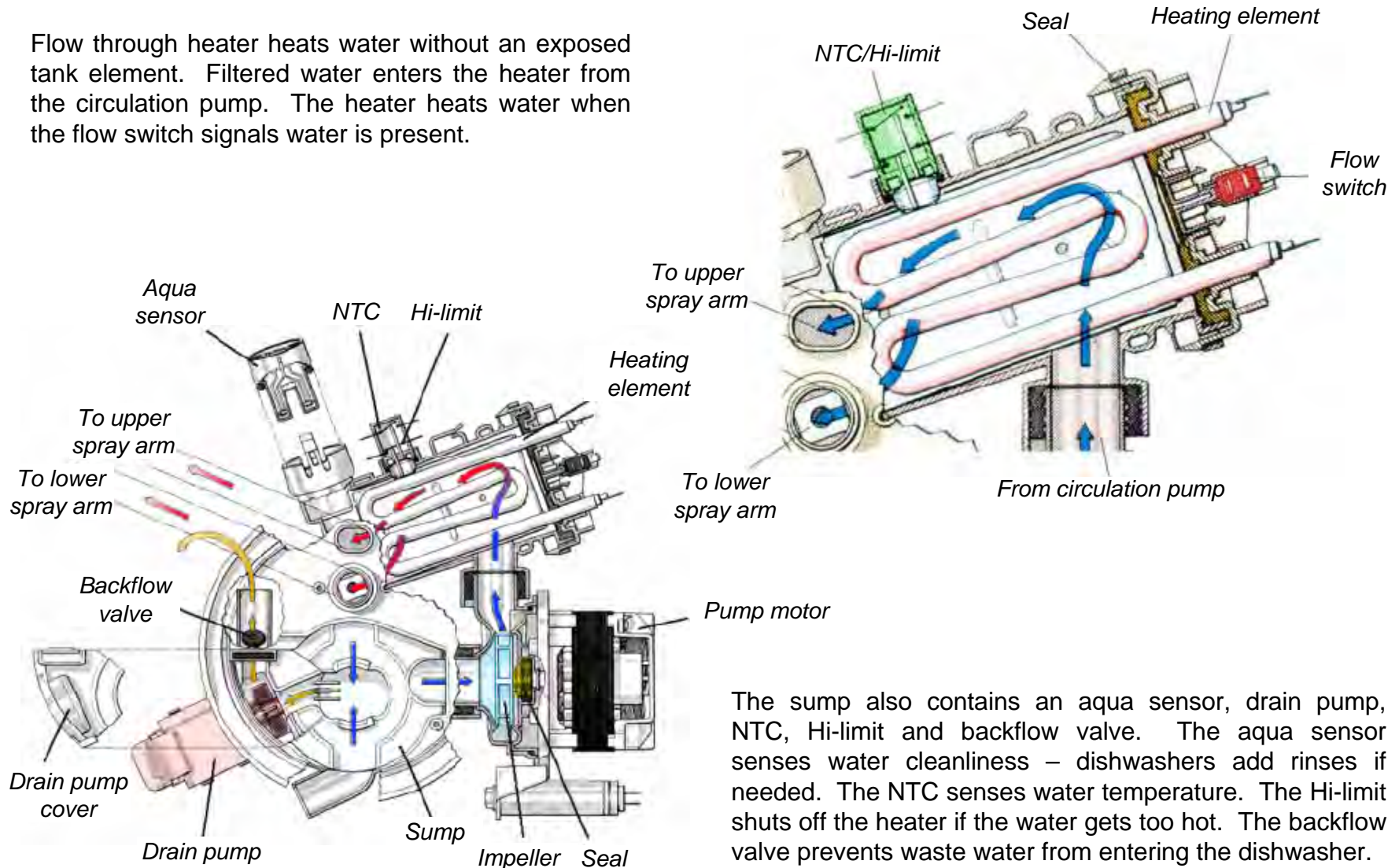

The sump also contains an aqua sensor, drain pump, NTC, Hi-limit and backflow valve. The aqua sensor senses water cleanliness – dishwashers add rinses if needed. The NTC senses water temperature. The Hi-limit shuts off the heater if the water gets too hot. The backflow valve prevents waste water from entering the dishwasher.

Service Tips -- Water Switch (“Flow Control”)

Motor operated water switches are mounted underneath heater assemblies. They consist of a motor-controlled disk (with 3 holes) which rotates and lines up over two sump ports (upper / lower spray arms) to provide precise water control to upper, lower or both spray arms.

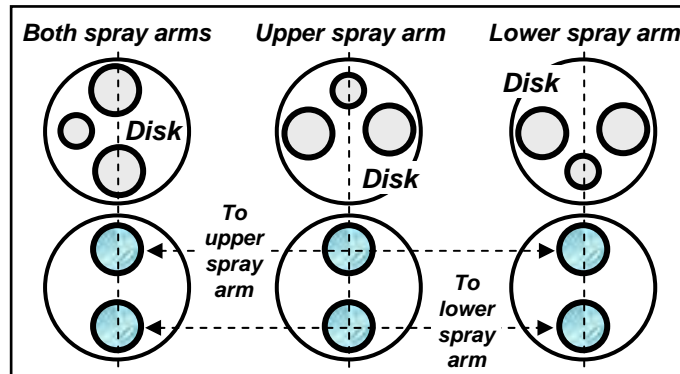
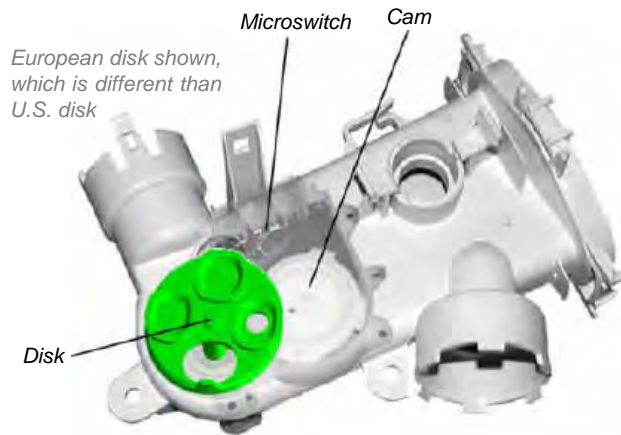

HINT: Models with water switches & *Top Rack Only* use water switches to divert water. Separate actuators aren't needed.

HINT: Models with water switches need stronger circulation pumps (# 437345) with separate motor starters (# 182318). Circulation pumps, heaters & sumps for water switch / non-water switch models **can't** be interchanged.

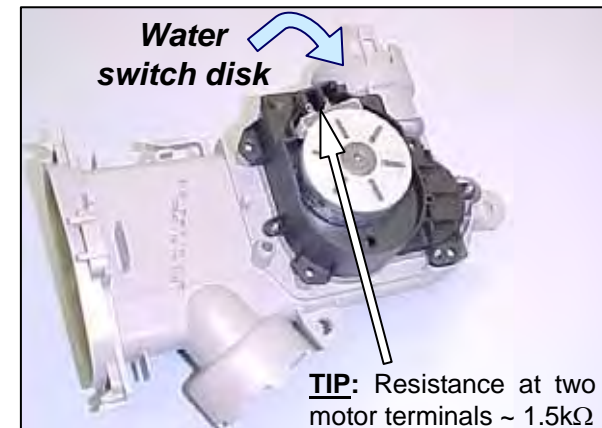
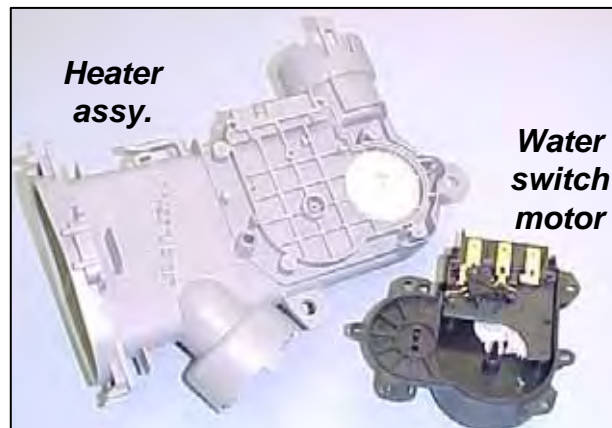
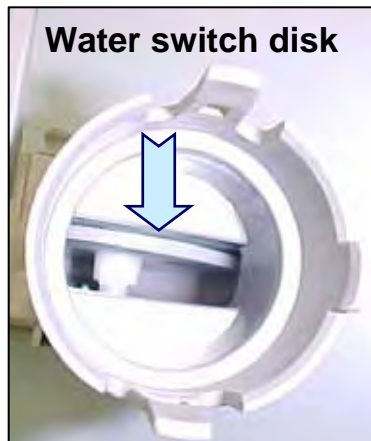

Service Tips – Top Rack Only

Models with *Top Rack Only* have separate actuators mounted underneath heater assemblies. The actuator moves a magnetic float to block the lower rack port, diverting water to the top rack.

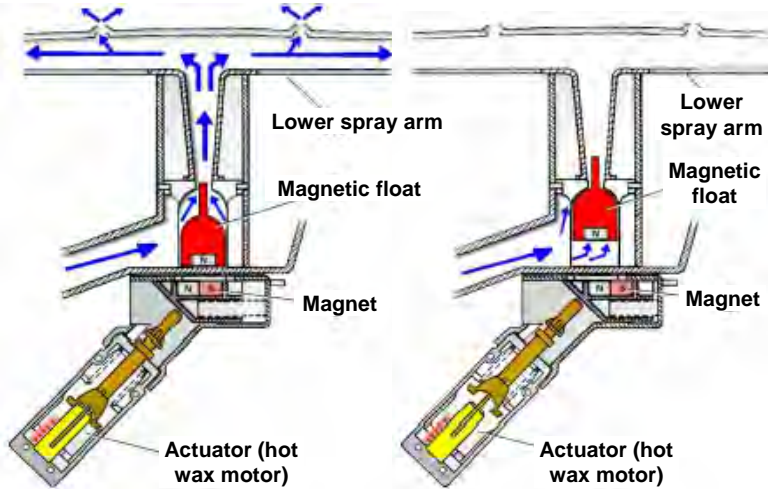
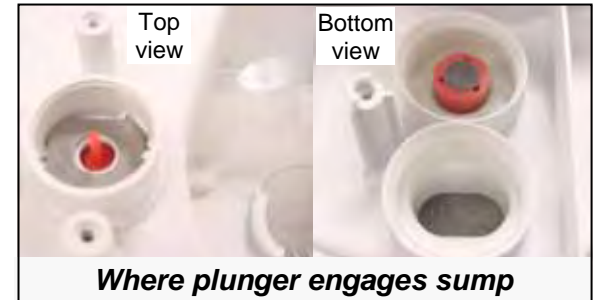
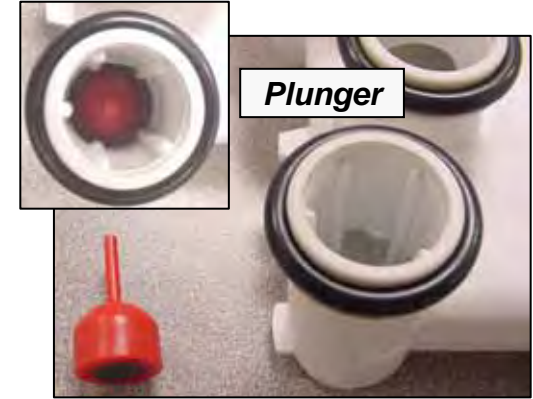

Models with water switches and *Top Rack Only* use water switches to divert water.

Models with *Half Load* use software to divert water.

The actuator moves a magnet under the magnetic float so the north poles align, repelling the magnetic float upward until it blocks the water flow to the lower spray arm.

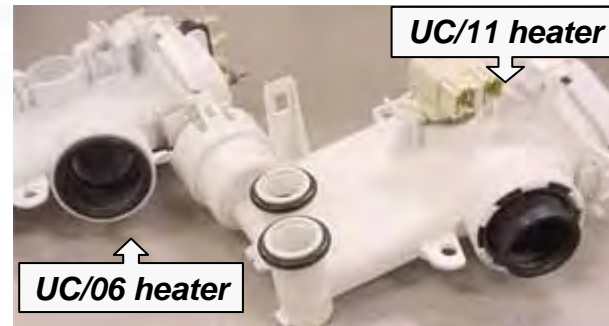

HINT: Don't use softer bearing heater assemblies (UC/11 & later) on older UC/06 models since sump, circulation pump, base and heater clamps/gaskets have to be replaced as well for heaters to fit.

Part # 5 -- Drain Pumps

Drain pumps are mounted to sumps in the front of dishwashers -- they're easily accessible from the front of dishwashers by removing toe kicks.

To remove & install drain pump:

Tools needed: small flat blade screwdriver (for unlocking terminals).

- Remove toe kick/base cover, pull up terminal cover and disconnect wires (using screwdriver to unlock locking terminals).
- To remove pump, pull latch (on circular collar) & rotate pump clockwise (cw). To install new pump, insert @ 2:00 position & rotate counterclockwise (ccw).
- Clean water & debris from base, then check float operation.
- Connect wires, then install base cover & toe kick.

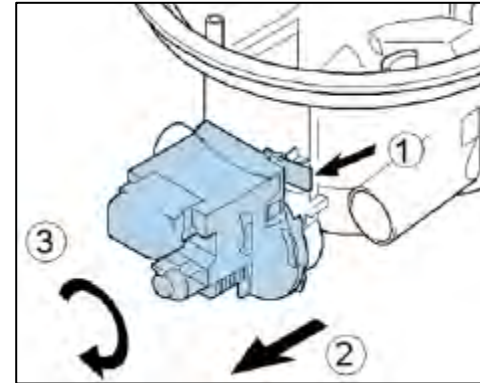

NOTE: Drain pump is rated 120V, 60 Hz, 35W, 0.85A.

DRAIN HOSE INSTALLATION TIPS:

- Must have drain hoses with high loops (min. 20" high) or drains with air gaps.
- Drain hoses can be up to 10' long – can add up to 4' to dishwasher hose.
- Secure drain hoses to rear of dishwashers with non-metal bands.
- Make sure drain hoses aren't kinked.

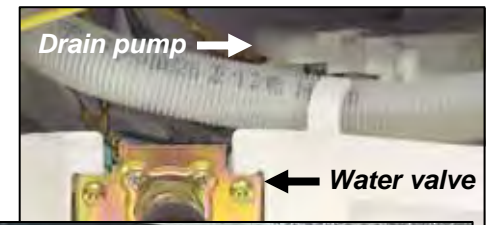

NOTE: Drain pumps in installations with Johnson Tees (in Washington State) must use stronger 4-vane pumps (# **184178**). Standard 9-vane drain pumps (# **167082**) are quieter and smoother than 4-vane pumps. Older pumps had 6-vanes.



TIP: Often improper installations, not drain pump issues, cause dishwashers to not drain properly.

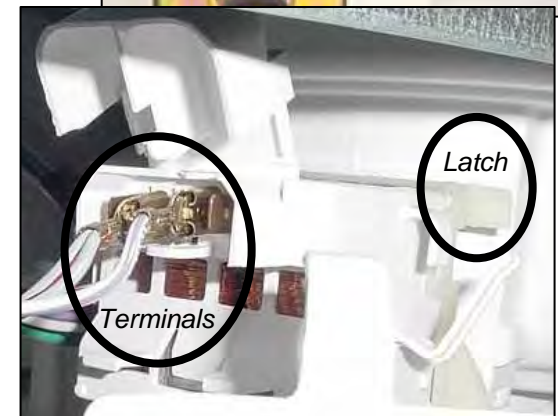

Service Tips – Improving Pump Flow

Using air gaps or (min. 20”) high loops is crucial to prevent drain pump cavitating and siphoning.

Cavitating may occur in any type of pump when impellers spin faster (from low inlet or outlet pressure), creating air pockets around impellers. Cavitating pumps can be noisy. Air gaps/high loops keep water contacting pump outlets, preventing air pockets from forming.

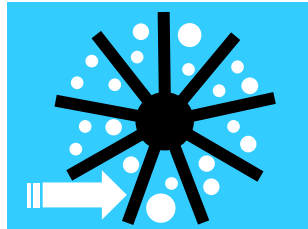

Siphoning may occur in any type of drain pump when low water flow allows a siphon (suction) to develop, pulling waste water back into the pump. Sump check valves along with air gaps/high loops prevent siphons from being created.

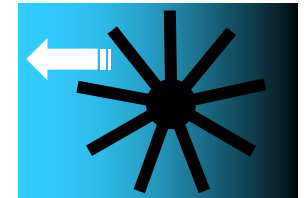

*Older pumps
had 6-vanes*



Old cover shown



During mid 2003, drain pump covers were changed to improve water flow and resistance to jamming. Part # is still **165263**.

Drain pump performance & washability can be optimized by replacing these parts:

Occasionally, check (backflow) valves have swelled, allowing water to trickle out during washing. The new (clear) material doesn't swell – new shape provides improved seating after many uses. Part # is still **165262**.



Old valve



New valve

TIP: When washability issues arise, replace check (backflow) valve along with other repairs.



Part # 6 -- Dispensers (1)

Disassembly

CAUTION: Inner door edges are sharp! Cover door edges and remove dispenser carefully.



Disconnecting wire harness



Bending retainer tabs



HINT: To remove/install dispensers:

- Remove outer door, remove fascia panel & disconnect wire harness from fascia panel.
- Disconnect wire harness above dispenser, then remove wires to wax motor & sensor.
- Disconnect condensation tube (for older models with condensation tubes in doors).
- Remove any tape or wire ties. Bring replacement wire ties for reassembly.
- Bend retainer tabs, then push dispenser inward toward tank. Protect hand with towel as inner door edges are sharp.
- Replace from inside of tank -- position O-ring seal and bend tabs to secure. Lubricate O-rings with rinse-aid & support inner doors to avoid damage if O-rings stick.

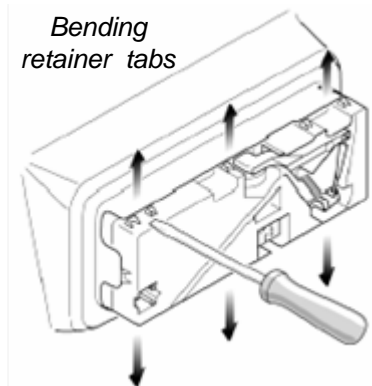

Part # 6 -- Dispensers (2)

During each wash program, the wax motor opens twice, once to dispense detergent and again to dispense rinse-aid. The wax motor opens the same -- linkages open the detergent door & operate the rinse-aid dosage plunger. Dispensers can have reed switches or optical rinse-aid sensors.

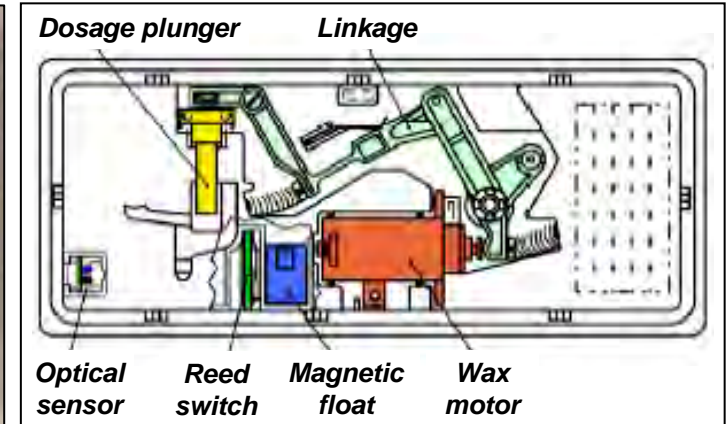

NOTE: The white plastic linkage opens the detergent dispenser door, then cocks in place to dispense rinse-aid when the wax motor operates again. After the 2nd operation, the linkage resets for the next wash.

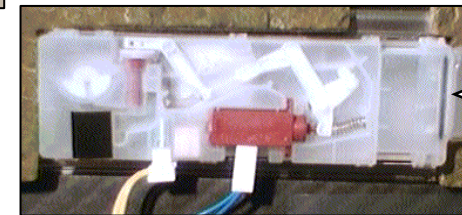

Condensation tube (older vented dispenser)

HINT: Optical dispensers have different connections and can't be substituted for reed switch dispensers. Note **431413** top load dispensers also use solenoid actuators instead of wax motors.

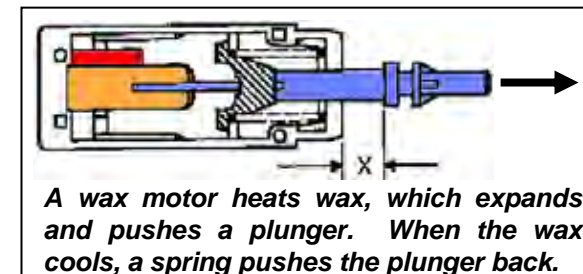
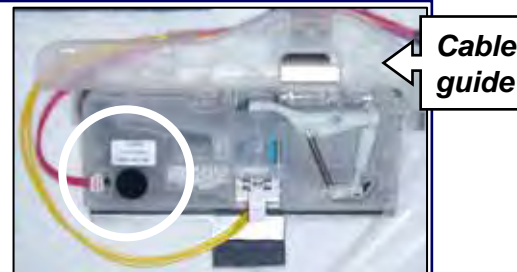

Part # 6 -- Dispensers (3)/Condensation Tubes

For UC/12 and later dishwashers, condensation tubes were moved (from dispensers) to the right side of tanks. This required a change from vented dispensers to unvented dispensers.



HINT: UC/12 (& later) model condensation tubes exit in the base behind the sump. There is no drain connection for these tubes.

HINT: Vented dispensers cannot be used to replace unvented dispensers. If they are, dishes won't dry properly and there can be water leaking inside dishwasher doors.

HINT: There are a limited number of UC/11 dishwashers with condensation tubes in tanks and with unvented dispensers. Treat them like UC/12 dishwashers.

Service Tips -- Replacing Dispenser Doors

Most dispenser problems occur from dispenser doors being damaged or pulled off (due to misuse). Please follow the instructions below when replacing doors.



1. Connect spring to door & dispenser housing posts.
2. While keeping spring attached to posts, carefully slide door onto housing -- making sure door tabs engage dispenser door rails.
3. Door levers don't need to be preset during installation.

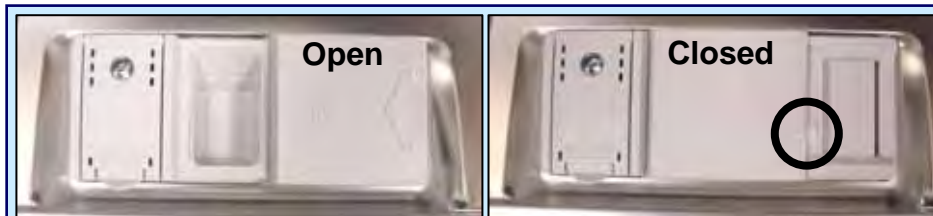

HINT: To close dispenser doors, slide doors closed, then push white lever until lever locks (showing doors are closed). Levers don't need to be preset during installation.

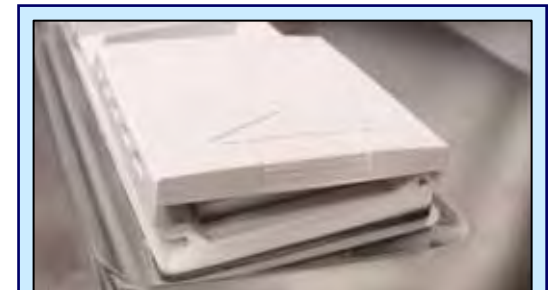

HINT: Make sure door tabs engage dispenser door rails.

Service Tips – Optical Sensor Dispensers

Optical and top-load dispensers measure rinse-aid levels with optical sensors instead of reed switches.

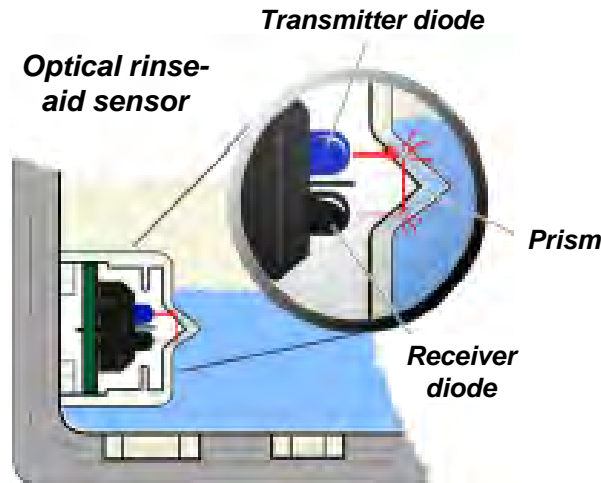

With rinse-aid present, the optical receiver senses a diffused light beam.

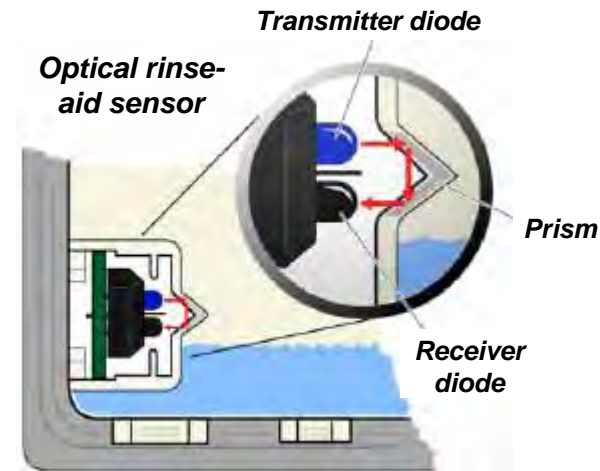

When rinse-aid has run out, the optical receiver senses a strong light beam.

HINT: Optical dispensers have different connections and can't be substituted for reed switch dispensers.

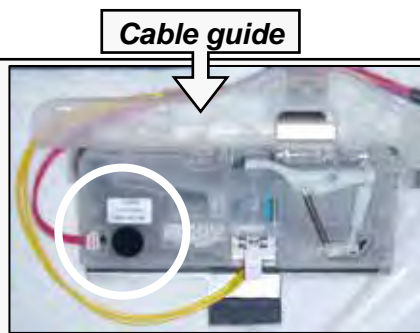

Standard dispenser



Top-load dispenser

NOTE: Top-load and standard dispensers are **NOT** interchangeable.

Service Tips -- Top Load Dispensers (1)

Top-load dispensers enable detergent and rinse-aid to be added while doors are partially open (preferably @ 45°). The dispensing mechanism uses a solenoid instead of an actuator (wax motor).

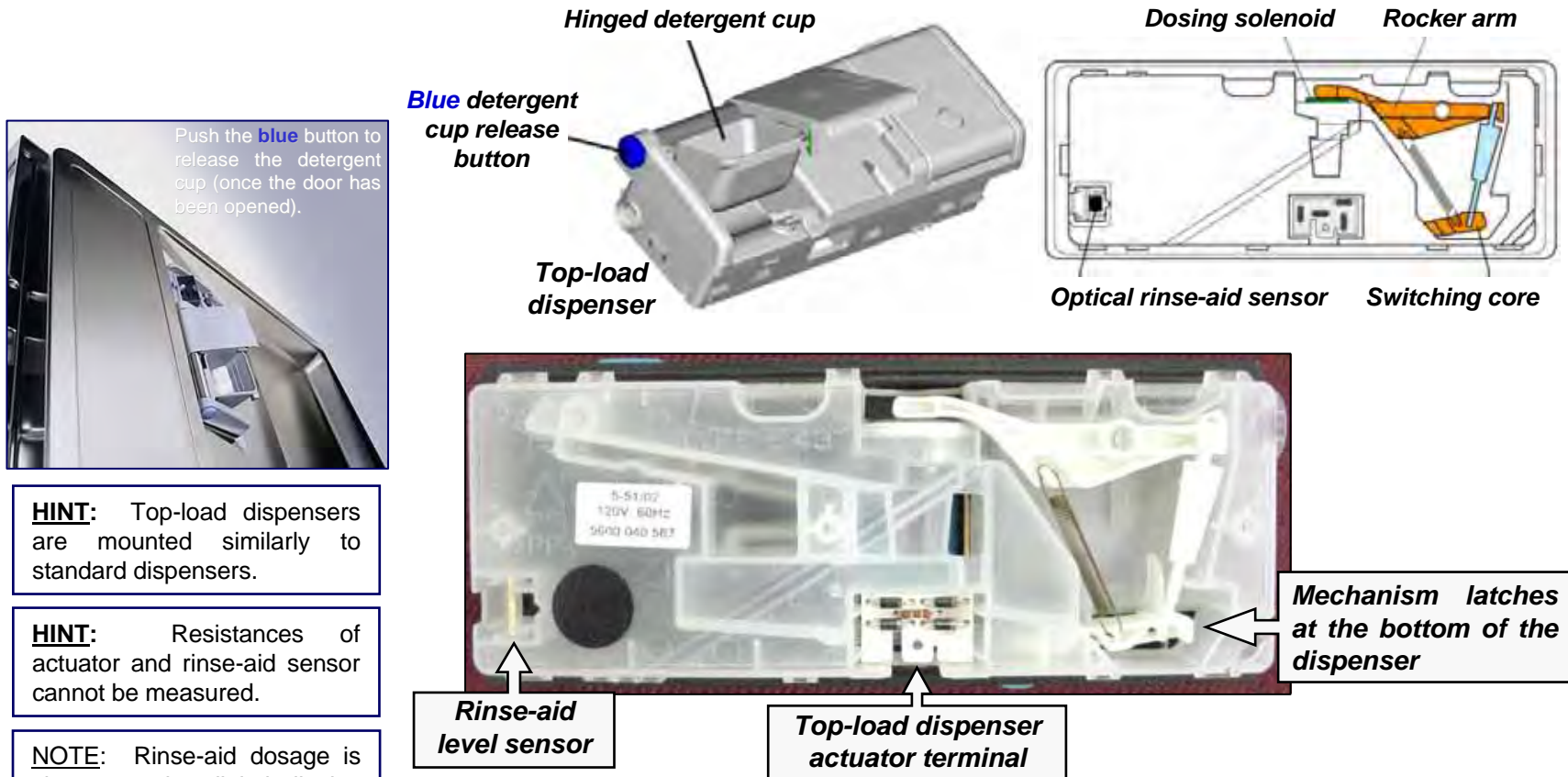

HINT: Top-load dispensers are mounted similarly to standard dispensers.

HINT: Resistances of actuator and rinse-aid sensor cannot be measured.

NOTE: Rinse-aid dosage is shown on the digital display and is changed through the dishwasher controls, not through a dispenser dial.

The plastic linkage opens the detergent dispenser door when the solenoid first operates, then cocks in place to dispense rinse-aid when the solenoid operates again. After the 2nd operation, the linkage resets for the next wash.

Part # 7 -- Top Ten Dishwasher Cosmetic/Customer Use/Installation Issues

1. Not cleaning or locking sump filters....
2. Smelly dishwashers....Often occurs from filters not being cleaned, drain hose high loops missing or drain gases being present. If all else is OK, then problem can be preservative not purged from tank door gasket.
3. Doors leaking or not latching....Usually an installation issue (dishwasher brackets installed before dishwashers are leveled front to back, tanks & doors out of square, wooden doors not drilled accurately). Can be blockage in condensation tubes or having condensation tubes connected to drain hose air gaps.
4. Inner door damage....From upper rack during improper shipping and handling (dishwashers clamped on wrong sides or dropped).
5. Doors hit toe kicks....Toe kick installation issue.
6. Junction boxes....Comes from wires not being connected correctly during installation.
7. Dispensers....Customers using too much detergent, not using rinse-aid & not knowing how to close the door.
8. Drain hoses not installed properly....Often no air gap or high loop + pinched hoses -- causes poor draining & smelly dishwashers. Most drain pumps are mistakenly replaced for drain hose installation issues.
9. Outer doors....Most are dinged during shipment.
10. Damaged water valves....Primarily from fittings being overtightened. A damaged valve can allow some water onto kitchen floors.

Service Tips -- Water Leaking Past Doors

Water seldom leaks out of bottom of dishwasher doors. Usually it's a customer or installation issue. Occasionally temporary blockages of condensation tubes by air pockets (from standing water in loops) or kinks in tubes causes leaking. Pressure builds in tanks, blowing water past lower door seals (usually at start of cycles). Draining condensation tubes and straightening out kinks solves these occasional problems.

Checklist if water leaks past doors:

- Make sure condensation tubes are inserted into bases, not connected to drains or air gaps.
- Clear and drain condensation tubes, including debris in bases.
- Re-drill wood doors to make them square.
- Straighten kinks in condensation tubes.
- Educate customer on oversudsing (from too much detergent/rinse-aid or overly soft water).
- Level dishwasher before attaching undercounter brackets.
- Replace damaged door seals, including replacements cut too short.
- Refill lower racks overfilled with dishes.
- Move flexible cutting boards to left side of dishwasher.

Part # 8 -- Door Latches (1)

Disassembly/ Installation

Other than occasional misalignment, the only door latch repairs will be replacing microswitches on fully integrated models (e.g. **SHV, SHX, SHY, DW44, SHU 88/99, SL84/A95A**, etc.). **SL34A** models also use these door latches.

To disassemble door latches for integrated models:

1. Remove T-20 Torx fascia panel screws from inner door.
2. Lower fascia panel from door.
3. Locate door latch in console.
4. Bend out console metal tabs to allow latch removal.

NOTE: Door latches for UC/14 & up models are different than UC/06 - UC/12 models -- they cannot be interchanged. Must replace strike plate & door latch together.



Remove panel screws



Lower fascia panel

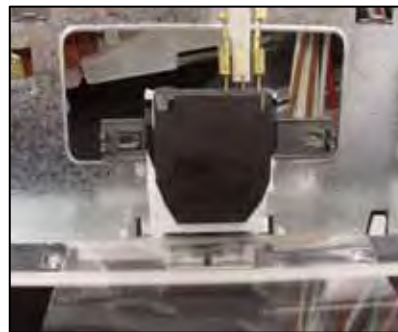

Door latch in console



Tabs (inner view)



Bend out metal tabs

Part # 8 -- Door Latches (2)

To remove & install door latches for integrated models (continued):

1. Remove door latch from console.
2. Disconnect wire harness, then remove microswitch & cover.
3. Disconnect wires, then remove microswitch from cover.
4. Replace microswitch, then reassemble.

HINT: Make sure plastic latch tabs are aligned & metal console tabs are bent back completely during reassembly.



Remove door latch



Remove microswitch



Microswitch



Replace cover (in slots)



Insert latch into tabs



Bend tabs back

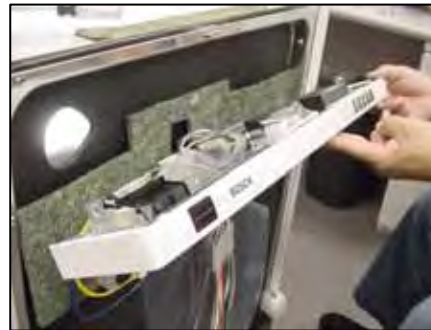

Replace fascia panel



Replace screws

Service Tips -- Misaligned latches

Occasionally integrated dishwasher door latches can be misaligned, causing doors to not close properly or dishwashers to run with doors open (when latches don't reset). Follow these steps to realign door latches.

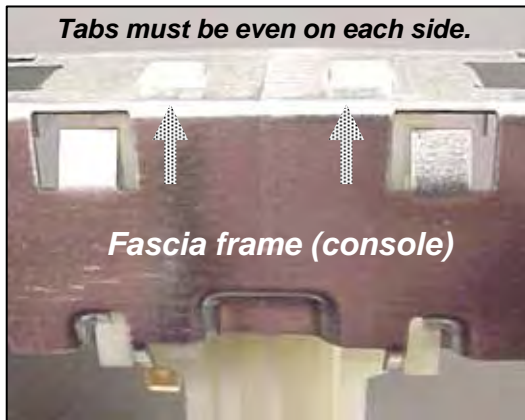

Insert latch tabs into frame

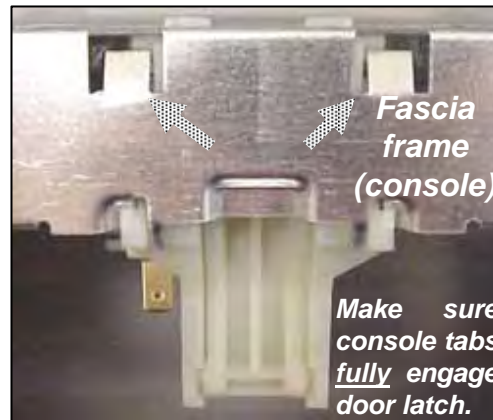

Bend tabs down into latch

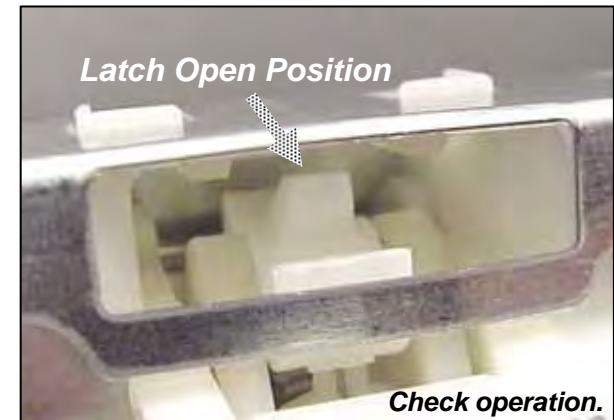

Reset latch to open position



HINT: Make sure latch tabs are seated, all fascia frame (console) tabs are bent completely, door strikes are aligned with latches and door latches get reset.



Service Tips -- Miswired latches

If replacement **SHV46/66**, **SHU995x**, **SHV68**, **SHX33/43/46**, **SHY56/66** or **SL95A** door latches/wire harnesses are miswired (with door latch terminals backwards), dishwashers run with doors open and lights won't turn on when doors are open. Control modules can be irreversibly damaged.



Rewiring door latches:

- Check wiring to photos at right – the double wire must be connected to the silver door latch terminal.
- With door open, turn on dishwasher – keep door open. If display doesn't turn on, immediately turn off dishwasher and reverse door latch terminal.

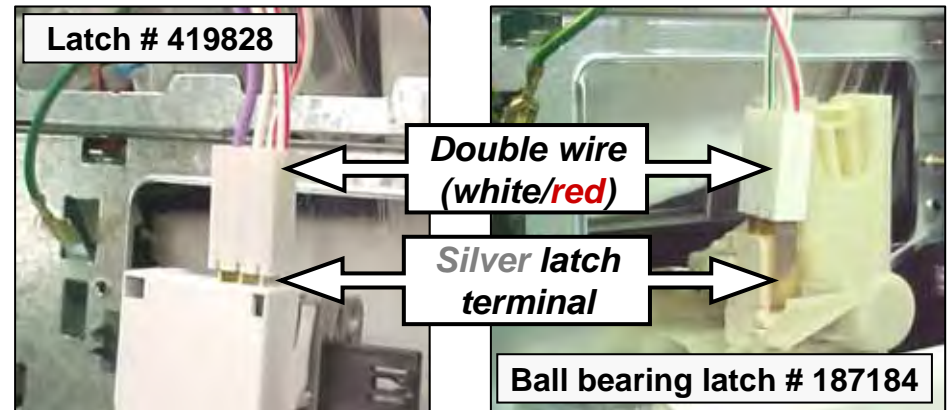

CAUTION: Operating dishwashers with miswired door latches will cause **irreversible** damage to control modules if doors have been closed and circulation pumps have started – modules must be replaced. Check door latch wiring whenever door latch terminals are changed or disconnected or when displays don't light up when dishwashers are turned on.

IMPORTANT: If dishwashers with miswired door latches are corrected before doors are closed and circulation pumps started, modules can still be used. If displays don't light up, turn off dishwashers and reverse door latch terminals before modules are damaged.

Part # 9 -- Aqua Sensors

The aqua sensor only affects energy usage, eliminating a pre-wash and/or pre-rinse cycle if water is clean. Most customers won't notice if an aqua sensor fails. It's located on the rear of the sump and can be reached through the left side of the dishwasher (after the left side panel is removed – see page 7). Its not necessary to block up the tank to reach the aqua sensor.

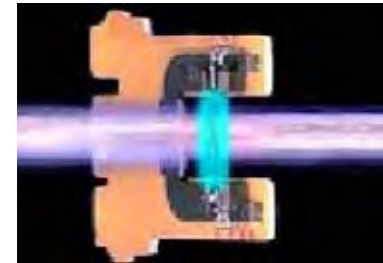
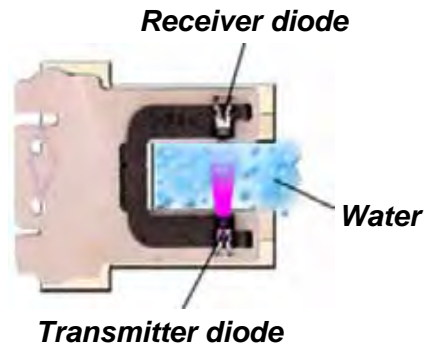
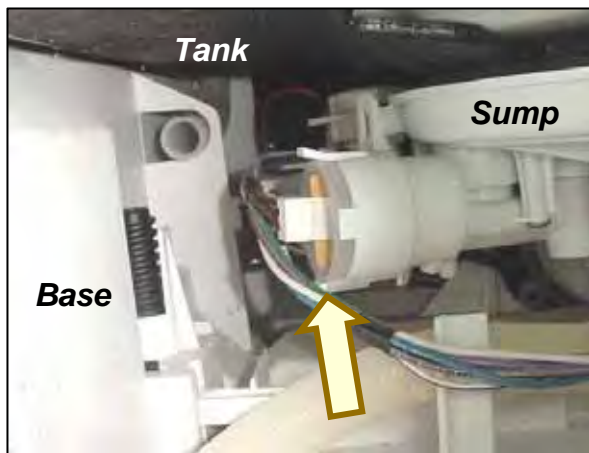

NOTE: Aqua sensors provide ~ 20% energy savings.

HINT: To change out the aqua sensor, pull off the connector and pull out the aqua sensor (toward the rear of the dishwasher). The aqua sensor slides into slots in the sump. Make sure the aqua sensor is properly inserted into the slots.

NOTE: The *Apex Sensotronic 2* aqua sensor # **175340** is similar to standard aqua sensor # **165279**, except it has two (red & green) soil sensors. They mount the same way, but are **not** interchangeable.

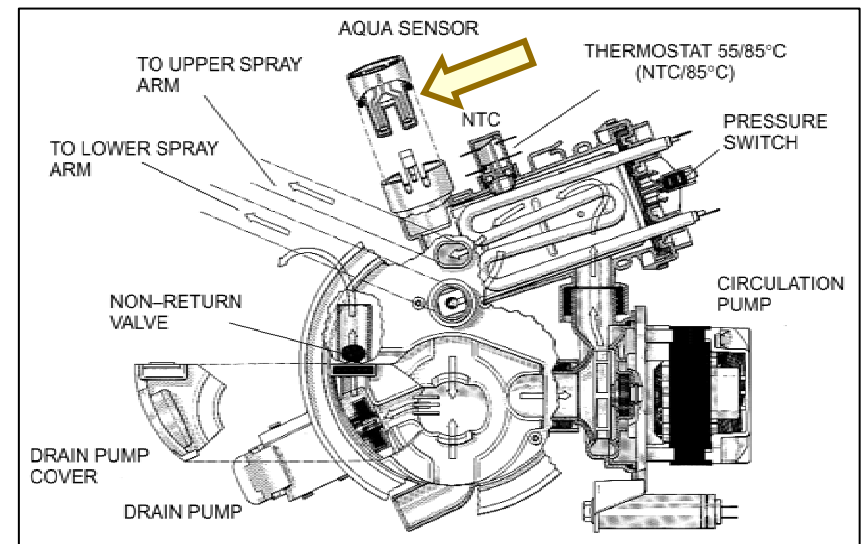

Part # 10 -- Water Fill Assembly

The water fill assembly is easily accessed from the left side by just removing the left side panel (see page 7). It can be a pressure-fill (with diaphragm) or time-fill, depending on model.

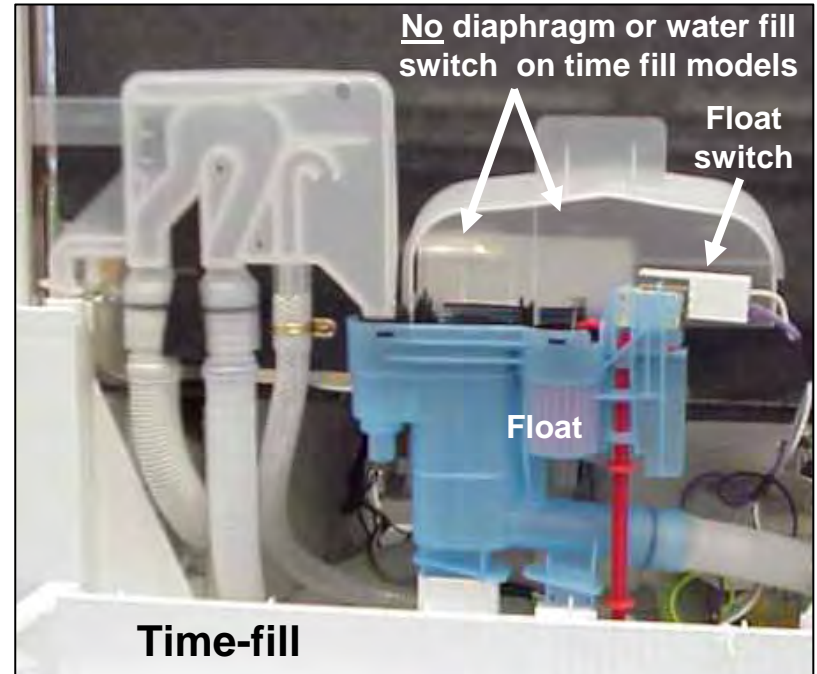
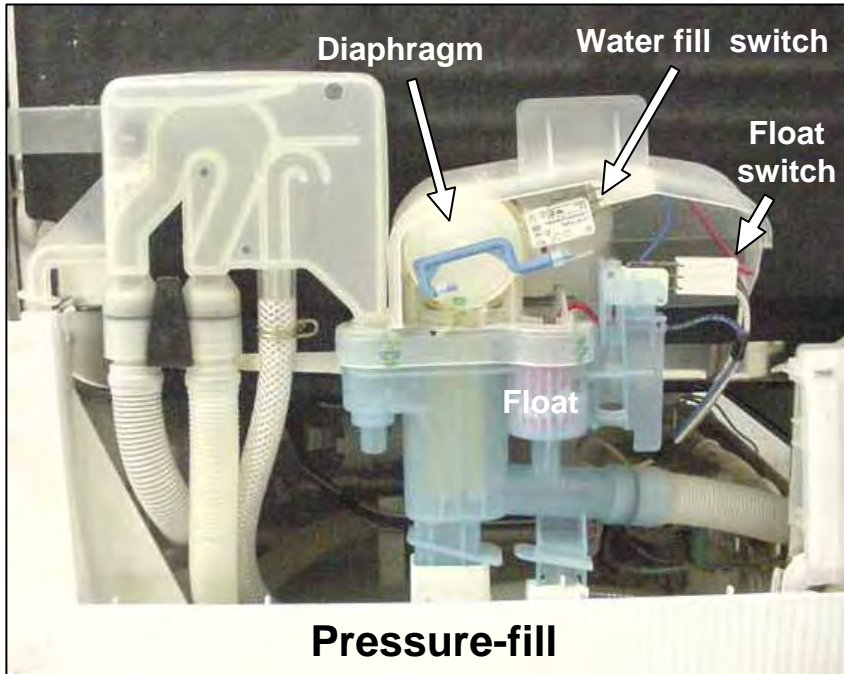

HINT: Most water fill assembly repairs involve replacing microswitches. Occasionally tank insulation or other debris can prevent the diaphragm switch lever from operating, allowing overfilling.

NOTE: Water inlet valves for time and pressure-fill look the same, but pressure-fill valves can't be used on time-fill models. Presently, both pressure-fill and time-fill models use time-fill valve **425458**.

TIP: Floats should be checked and bases should be cleared of water & debris whenever water fill assemblies are worked on.

Miscellaneous Service Tips – Terminal Blocks

Since 8/15/06 (UC/40 & up), all dishwashers have terminal blocks instead of wires and wire nuts. Make terminal connections directly to terminal block.



NOTE: Dishwashers with index #'s from UC/36 – UC/39 use the same new base as UC/40 dishwashers, but with a terminal box (with wires to be connected by wire nuts). These new bases, terminal blocks and terminal boxes **can't** be used on older dishwashers (UC/35 & earlier).

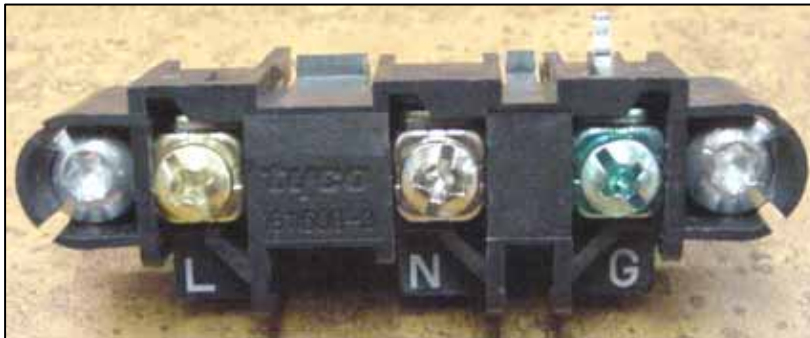

NOTE: Terminals are clearly marked:

1. Color coded with gold (hot/line), silver (neutral) & green (ground).
2. Marked with symbols: L (hot/line), N (neutral) & G (ground).

Miscellaneous Service Tips – Terminal Box Covers

Since 9/23/02, all dishwashers have terminal boxes (“junction boxes” / “J-boxes”) with covers. Boxes were upgraded to a larger style (with conduit exits) on 3/18/03.



Old terminal box

Used from 9/23/02 – 3/17/03.

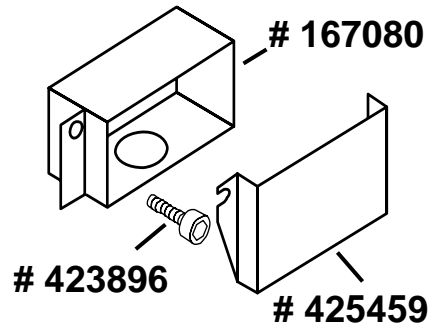

Old terminal box with cover

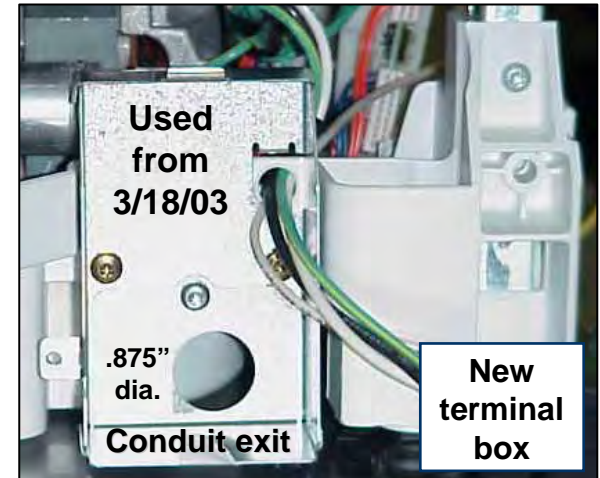

TIP: Proper installation requires strain relief on power cords/conduit! Use 3/8” or 1/2” fittings with .875” diameter.

Upgraded
box with
cover

Used
from
3/18/03



Upgraded box with
cover

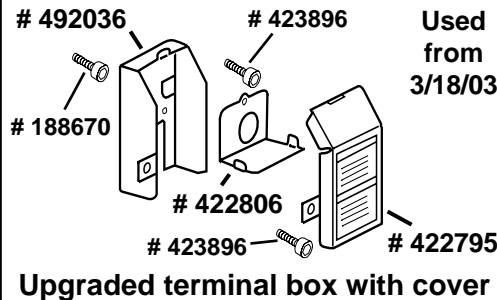

Upgraded terminal box with cover

NOTE: Old terminal boxes built before 9/22/02 met UL standards – toe kicks were approved as terminal box covers. There's no need to change out old terminal boxes. Covers can't be added to these boxes since they don't have cover screw holes.

NOTE: Power cords entered bottom of old terminal boxes & rear of new terminal boxes.

NOTE: SHU68 46dB models used terminal box covers since 2/28/00.

NOTE: Replacement 167080 J-boxes have cover screw holes.

Miscellaneous Service Tips – Hinge Levers & Bushings

Since 12/15/03, all dishwashers have upgraded hinge levers and hinge bushings. New hinge levers and bushings can't be used with old bushings and levers – must replace levers and bushings together.

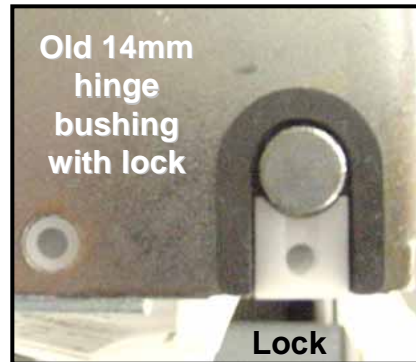

NOTE: New and old hinge levers and bushings can't be mixed and matched since new hinge levers have 15mm holes to fit new hinge bushings and old hinge levers had 14mm holes for old hinge bushings (and locks).

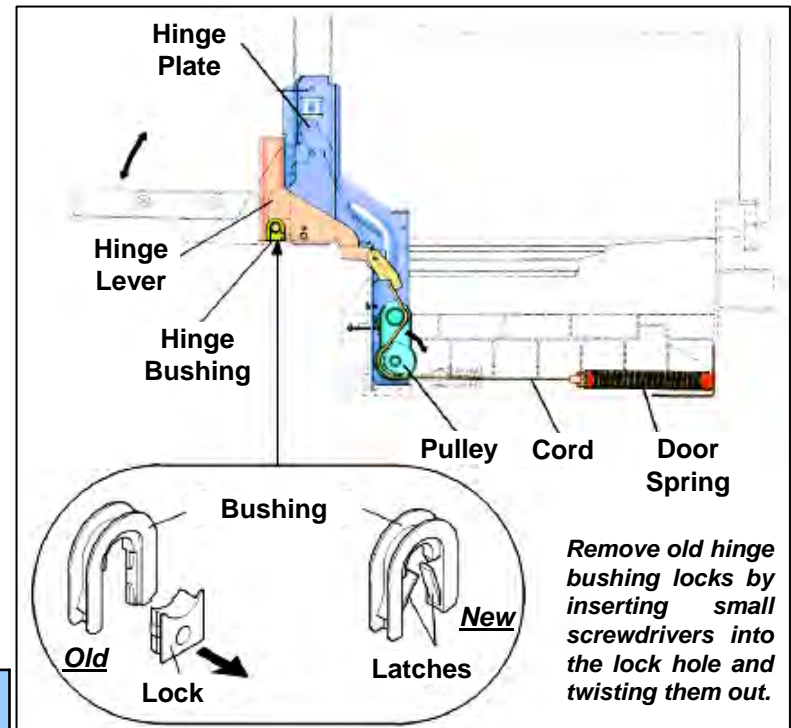

TIP: Unlike old hinge bushings, new hinge bushings are self-locking and don't need separate locks. To remove doors when new hinge bushings are used, spread latches apart until door pins clear latches.

NOTE: When new 15mm hinge bushings (with latches) are opened, replace them instead of reusing them.

Replacement Hinge Levers and Bushings

Side	Part #	Description	Replaced by	Description
Left	492033	Lever (14mm)	494876 + 165296	Lever + bushing (15mm)
Left	488250	Bushing (14mm)	494876 + 165296	Lever + bushing (15mm)
Left	263115	Lever + bushing (14mm)	494876 + 165296	Lever + bushing (15mm)
Right	492034	Lever (14mm)	494875 + 165296	Lever + bushing (15mm)
Right	488250	Bushing (14mm)	494875 + 165296	Lever + bushing (15mm)
Right	263119	Lever + bushing (14mm)	494875 + 165296	Lever + bushing (15mm)

Miscellaneous Service Tips – Spray Arm Feed Tubes

When water doesn't spray from upper spray arms, check feed tube (350321) where it enters the sump. Occasionally, the joint between the feed tube and its base can loosen -- the entire feed tube must be replaced.

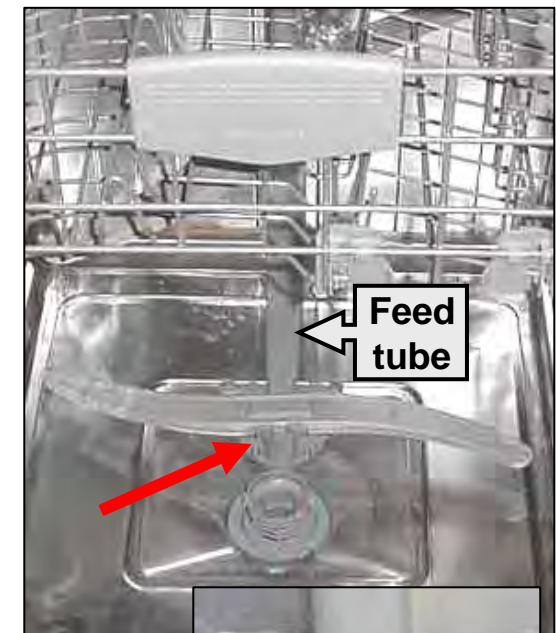
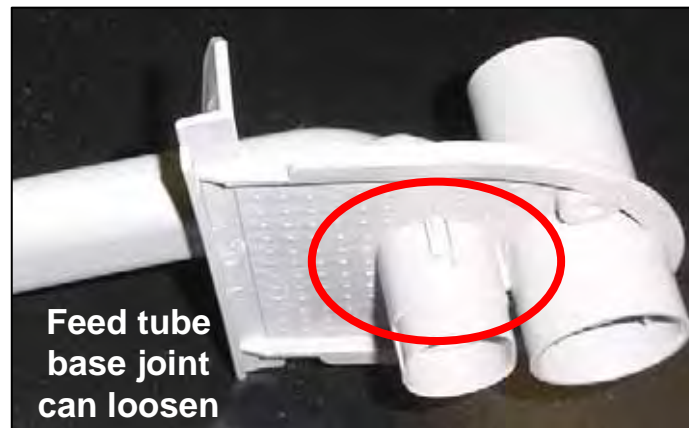
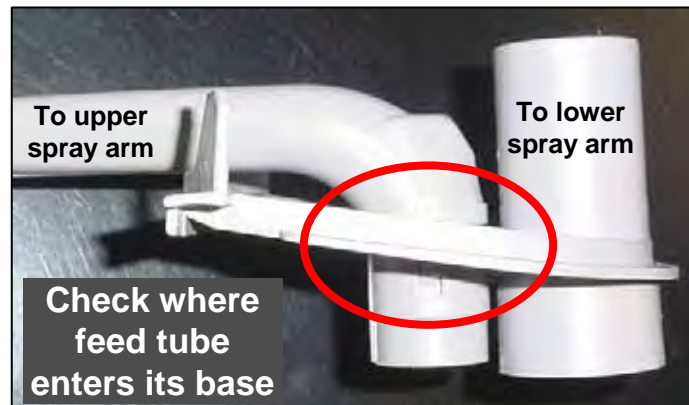
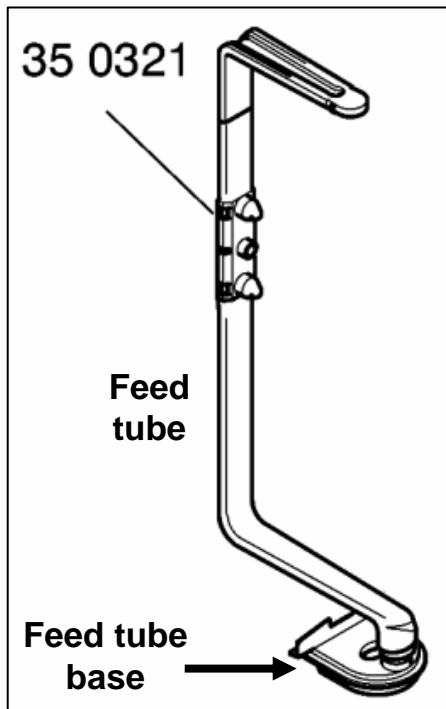

Miscellaneous Service Tips – Info Lights

SHV57C03/99A13, SHX57C05/99A15 & DWHD94 models have *Info Lights*, which shine a **red** light onto floors, letting customers know their quiet dishwashers are running. When dishwashers finish wash cycles, *Info Lights* shut off.

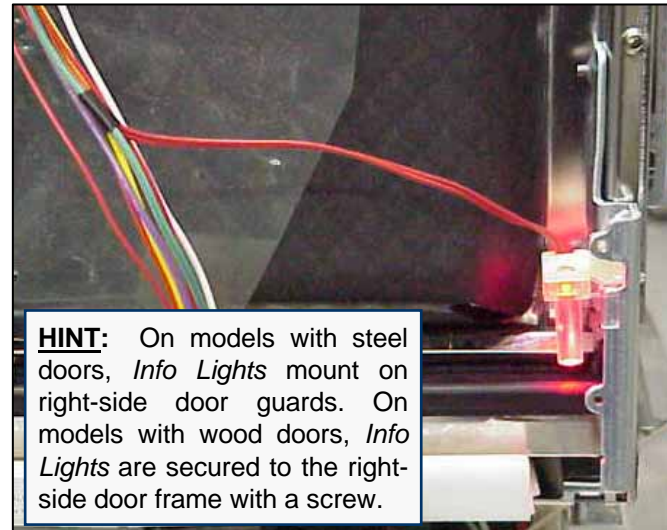
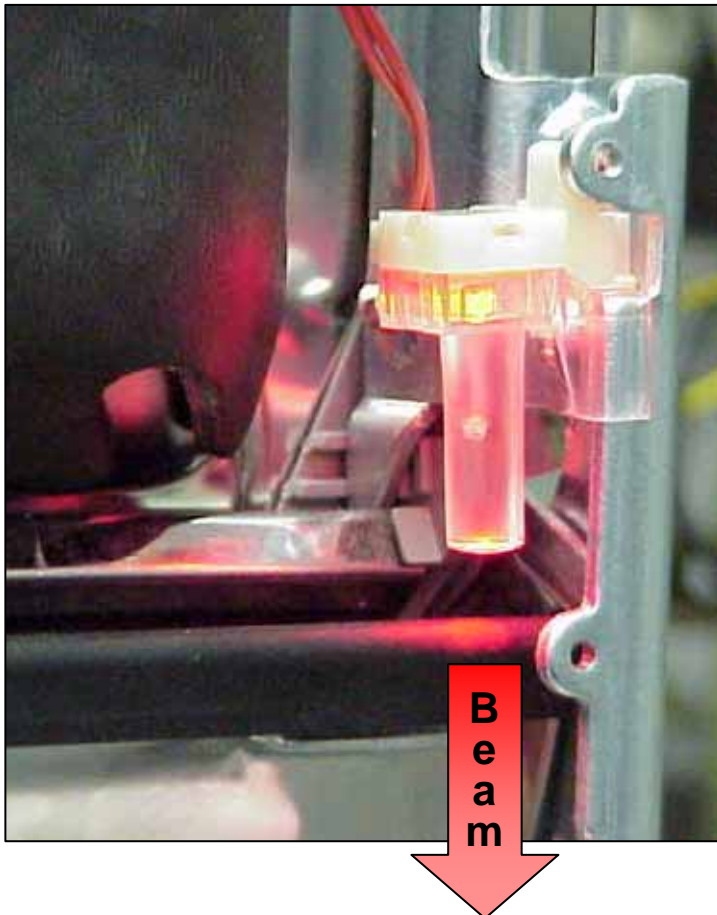

Miscellaneous Service Tips – Ratings

- **Dishwasher ratings** – Dishwashers are rated 120VAC, 60 Hz, 15A, 1450W (max.). Maximum amp draw when heaters running ~ 11A.
- **Heater ratings** – 120VAC, 1200W, flow-through, heats water ~ 2°F / minute.
- **Noise level** – Dependent on model, from 44 db – 56 dB.
- **Circulation pump ratings (Sicasym motor)** – 120VAC, 60 Hz, 120W (~ .16 HP), insulation class A, with auto-reset thermal protector, 35μF capacitor.
- **Circulation pump ratings (two-winding motor)** – 120VAC, 60 Hz, 160W (~ .21 HP), insulation class A, with auto-reset thermal protector, 10μF capacitor.
- **Drain pump ratings** – 110 - 127 VAC, 60 Hz, 35W, .84A, 17Ω, 9-vane (4-vane & older 6-vane pump have same ratings).
- **Water inlet pressure range** – From 5 – 120 psi (.3 – 8.27 bar).
- **Circulation pump flow rate** – Approximately 60 liters/minute (~ 15.85 gallons/minute) at a pressure of 420 mbar (6.1 psi).
- **Drain pump flow rate** – Approximately 10 liters/minute (~ 2.64 gallons/minute) at a delivery height (head) of .9m (2.95’).
- **Water inlet valve flow rate** – Approximately 2 liters/minute (~ .5 gallons/minute).

Miscellaneous Service Tips – FAQ's (1)

- **Dimensions** – 33-7/8” H x 23-9/16” W x 22-7/16” D (86.0 cm x 59.8 cm x 57.0 cm). Depth dependent on model (greater depth with door handle).
- **Cutout dimensions** – 23-5/8” - 24-1/8” (600 - 613 mm) H x minimum 33-15/16” (862 mm) W x 22-7/16” (570 mm) D.
- **Cabinet fitting** – Fits European cabinets (as is) and American cabinets (with trim strips provided with every unit).
- **Drain hose** – Extends 6’ beyond dishwasher (7’ long total). Can add up to 4’ extension (total hose length up to 10’ beyond dishwasher).
- **Drain hose diameter** – Better to match customer connections to drain hose adapter, which has 19.5mm (.77”) I.D. – compare to O.D. of customer connection. Nominal I.D. of adapter = 14.5mm (.57” or ~ 9/16”) – compare to nominal plumbing sizes.
- **Top Rack Only water usage** – 30% less than when both spray arms are running (take rated usage x .7).
- **OptiMiser timing** – Runs 30% less time than standard wash cycles.
- **Stainless steel alloy used** – 304 (“S30400”)

Miscellaneous Service Tips – FAQ's (2)

- 
- **Door spring ratings** – Dependent on model, see below:
 - **Yellow** (dot) spring # 173696 – Used with SHU steel doors with inner doors with 2mm bitumen.
 - **Blue** (dot) spring # 168576 – Used with SHU/SHX/SHY steel doors with inner doors with 4mm bitumen.
 - **White** (dot) spring – Used with SHU steel doors with SGZ door kits with differently colored steel panel. Not available separately.
 - **Violet** (dot) spring # 168568 – Used with SHI wooden doors weighing 4.85 – 20.94 lbs. (2.2 – 9.5 kg).
 - **Orange** (dot) spring # 182640 – Used with SHV wooden doors weighing 7.0 – 24-1/4 lbs. (3.2 – 11 kg).
 - **Toe kick heights** – Can be adjusted from 3-1/2” to 7”. Cannot be adjusted below 3-1/2”.
 - **Water connection** – 3/8” NPT female.
 - **Recommended water inlet temperature** – 120°F (49°C).
 - **Net weight** – Dependent on model, typically 123 lbs. (56 kg).

Miscellaneous Service Tips – FAQ's (2)

- Wood door spring usage chart – Once original door spring has been identified (**Orange 182640** or **Violet 168568**), use chart below to adjust spring tensions:

	Door Wood Panel Weight				
Existing Door Spring	Less than 5.5 lbs (2.5 kg)	5.5 to 9 lbs (2.5 to 4.1 kg)	9 to 15 lbs (4.1 to 6.8 kg)	15 to 18 lbs (6.8 to 8.2 kg)	18 to 21 lbs (8.2 to 9.5 kg)
Violet (168568)	Change to 173696 Yellow spring - use tension screw if needed	Change to 168576 Blue spring - use tension screw if needed	No action	Use tension screw to increase tension	Change to 182640 Orange spring - use tension screw if needed
Orange (182640)	Change to 168576 Blue spring - use tension screw if needed	Change to 168568 Violet spring	No action	Use tension screw if needed to increase tension	Use tension screw to increase tension