



# Technician Manual

## Clean Design Electro-Mechanical Dishwashers

GSD400T

GSD500T

GSD530T

GSD550T

GSD650T

GSD680T

GSD700T

GSD730T

GSD750T

GSD780T

GSD800T

GSD830T

GSD900T

GSD930T

GSD950T

GSD980T

GSD1200T

GSD1230T

GSD1350T

GSD1380T

GSD1400T

GSD1410T

GSD1420T

GSD1430T

GSD1910T

GSD1920T

GSD1930T

GSC700T

GSC800T

GSC1200T

GSM603T

# **CleanDesign Dishwashers**

## **TABLE OF CONTENTS**

<b>Electro-Mechanical Built-In Models .....</b>	<b>i</b>
<b>Electro-Mechanical Portable/Convertible/Undersink Models .....</b>	<b>ii</b>
<b>General/Exploded Wash Arms Views .....</b>	<b>1</b>
<b>Wash Arm Service .....</b>	<b>2</b>
<b>Sump Service/Calrod Redesign.....</b>	<b>3</b>
<b>Etscutcheon/Low Travel Switch .....</b>	<b>4</b>
<b>Control Panel Assembly &amp; Service .....</b>	<b>5</b>
<b>Cycle Extender Operation (GSD1400T).....</b>	<b>6</b>
<b>Cam Chart/Water Fills.....</b>	<b>7</b>

# CleanDesign Dishwasher Models

## ELECTRO-MECHANICAL BUILT-IN

<b>MODEL GSD:</b>	1910T 1920T 1930T	1400T 1410T 1420T 1430T	1350T 1380T	1200T 1230T	950T 980T	900T 930T	800T 830T	750T 780T	700T 730T	650T 680T	500T 530T 550T	400T
<b>Tub Flange Trim</b>	C	NONE	NONE	NONE	NONE	NONE	NONE	NONE	NONE	NONE	NONE	NONE
<b>Cycle Start</b>	TURN	TURN	TURN	TURN	TURN	TURN	TURN	TURN	TURN	TURN	TURN	TURN
<b>Cycles</b>	10	8	8	7	6/4	6	5	5	5	5	5	1
<b>Normal Wash</b>	1 LT	1 LT	1 LT	1 LT	1 LT	1 LT	1 LT	1 LT	1 LT	1 PB	DIAL OR 1PB	DIAL
<b>Rinse and Hold</b>	1 LT	1 LT	1 LT	DIAL	DIAL	DIAL	DIAL	DIAL	DIAL	DIAL	DIAL	---
<b>Short Wash</b>	DIAL	DIAL	DIAL	DIAL	---	DIAL	DIAL	DIAL	DIAL	DIAL	DIAL	---
<b>Potscrubber</b>	1 LT	1 LT	1 LT	1 LT	1 LT	1 LT	1 LT	1 LT	1 LT	1PB	---	---
<b>Water Saver</b>	1 LT	1 LT	1 LT	1 LT	1 LT	---	---	---	---	---	OR 1PB	---
<b>Heavy Wash</b>	---	---	---	---	---	---	---	---	---	---	---	---
<b>Light Wash</b>	1 LT	---	---	1 LT	1 LT	1 LT	1 LT	---	---	---	---	---
<b>China Crystal</b>	1 LT	1 LT	1 LT	---	---	---	---	---	---	---	---	---
<b>Plate Warmer</b>	DIAL	DIAL	DIAL	DIAL	DIAL	DIAL	DIAL	DIAL	DIAL	DIAL	---	---
<b>Options</b>												
<b>Soil Level</b>	---	---	---	---	---	---	---	---	---	---	---	---
<b>Start</b>	---	---	---	---	---	---	---	---	---	---	---	---
<b>Delay Start</b>	DIAL 10 HR	DIAL 10 HR	DIAL 8 HR	DIAL 6 HR	---	---	---	---	---	---	---	---
<b>Heated Dry on/off</b>	2 LT	1 LT	1 LT	1 LT	1 LT	1 LT	RKR	RKR	RKR	2 PB	RKR OR 2PB	RKR
<b>Heated Wash on/off</b>	2LT	1 LT	1 LT	1 LT	1 LT	1 LT	2LT	2LT	---	---	---	---
<b>Energy Saver</b>	---	1 LT	1 LT	1 LT	1 LT	1 LT	---	---	---	---	---	---
<b>Clr/Reset/Cancel</b>	---	---	---	---	---	---	---	---	---	---	---	---
<b>Calrod Watts</b>	500	500	500	500	500	500	500	500	500	500	500	500
<b>T-stat/T-mister</b>	TIMED	TIMED	TIMED	TIMED	TIMED	TIMED	TIMED	TIMED	TIMED	TIMED	TIMED	TIMED
<b>Water Heat Ext.</b>	YES	YES	YES	YES	YES	YES	YES	YES	YES	YES	---	---
<b>Indicator Lights</b>	9	7	8	7	6	6	4	3	0	0	0	0
<b>Wash Levels</b>	3	3	3	3	3	3	3	3	3	2	2	2
<b>Mid Level Wash</b>	4 PC/TR	4 PC/TR	4 PC/TR	4 PC/TR	4 PC/TR	4 PC/TR	4 PC/TR	4 PC/TR	4 PC/TR	4 PC/TR	4 PC/TR	4 PC/TR
<b>Lower Wash Arm</b>	SWA	SWA	SWA	SWA	STD	STD	STD	STD	STD	STD	STD	STD
<b>Filter System</b>	YES	YES	YES	YES	YES	YES	NO	NO	NO	NO	NO	NO
<b>Drain Pump</b>	NO	NO	NO	NO	NO	NO	NO	NO	NO	NO	NO	NO
<b>Warranty-Years</b>	1/2/5/20	1/2/5/20	1/2/5/20	1/2/5/10	1/2/10	1/2/10	1/2/10	1/2/10	1/2/10	1/2/10	1/10	

# CleanDesign Dishwasher Models

## ELECTRO-MECHANICAL PORTABLE\CONVERTIBLE\UNDERSINK

<b>MODEL GSC/GSM:</b>	<b>GSC 1200T</b>	<b>GSC 800T</b>	<b>GSC 700T</b>	<b>GSM 603T UNDER- SINK</b>
<b>Tub Flange Trim</b>	NONE	NONE	NONE	NONE
<b>Cycle Start</b>	TURN	TURN	TURN	TURN
<b>Cycles</b>	7	6	5	4
<b>Normal Wash</b>	1 LT	1 LT	1 LT	1PB
<b>Rinse and Hold</b>	DIAL	DIAL	DIAL	---
<b>Short Wash</b>	DIAL	DIAL	DIAL	DIAL
<b>Potscrubber</b>	1 LT	1 LT	1 LT	1PB
<b>Water Saver</b>	1 LT	---	---	---
<b>Heavy Wash</b>	---	---	---	---
<b>Light Wash</b>	1 LT	1LT	---	DIAL
<b>China Crystal</b>	---	---	---	---
<b>Plate Warmer</b>	DIAL	DIAL	DIAL	---
<b>Options</b>				
<b>Soil Level Start</b>	---	---	---	---
<b>Delay Start</b>	DIAL 6HR	---	---	---
<b>Heated Dry on/off</b>	1LT	RKR	RKR	2PB
<b>Heated Wash on/off</b>	1LT	2LT	---	---
<b>Clr/Reset/Cancel</b>	---	---	---	---
<b>Calrod Watts</b>	500	500	500	500
<b>T-stat/T-mister</b>	TIMED	TIMED	TIMED	TIMED
<b>Water Heat Ext.</b>	YES	YES	YES	YES
<b>Indicator Lights</b>	7	4	2	0
<b>Wash Levels</b>	3	3	3	2
<b>Mid Level Wash</b>	4 PC/TR	4 PC/TR	4 PC/TR	3 PC/TR
<b>Lower Wash Arm</b>	SWA	STD	STD	STD
<b>Filter System</b>	YES	NO	NO	NO
<b>Drain Pump</b>	NO	NO	NO	NO
<b>Warranty-Years</b>	1/2/10	1/2/10	1/2/10	1/2/10

DWF 8/93



## CleanDesign DISHWASHER

The new "CleanDesign" dishwasher line has been developed to satisfy a reduction in energy requirements and to add new model features. The changes are in number of cycles, time of fills, wash arm configuration, appearance, control panel cover, sump cover, filter frame, piston and nut shaft height, Calrod shape, new Low Travel switches and indicator lights. A styrofoam moisture barrier has been changed in the inner door. The power shower hose is smaller diameter, and on the low end models is packed with the clamp and placed in the upper rack for shipment.

The appearance is a continuation of the "EURO" look flush front, and the model line Low Travel switches and Indicator lights give the electro-mechanical models the "electronic" look. Use of chrome trim has been reduced and matching color trim is the norm.

### "SmartWash" Wash Arm

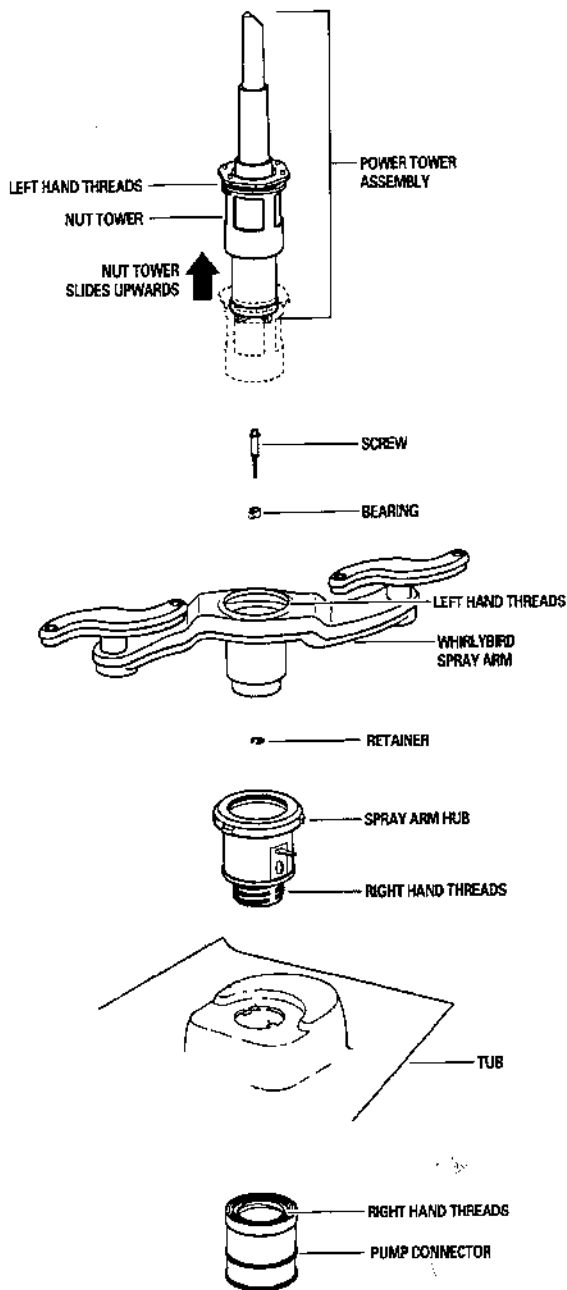

### Standard Wash Arm

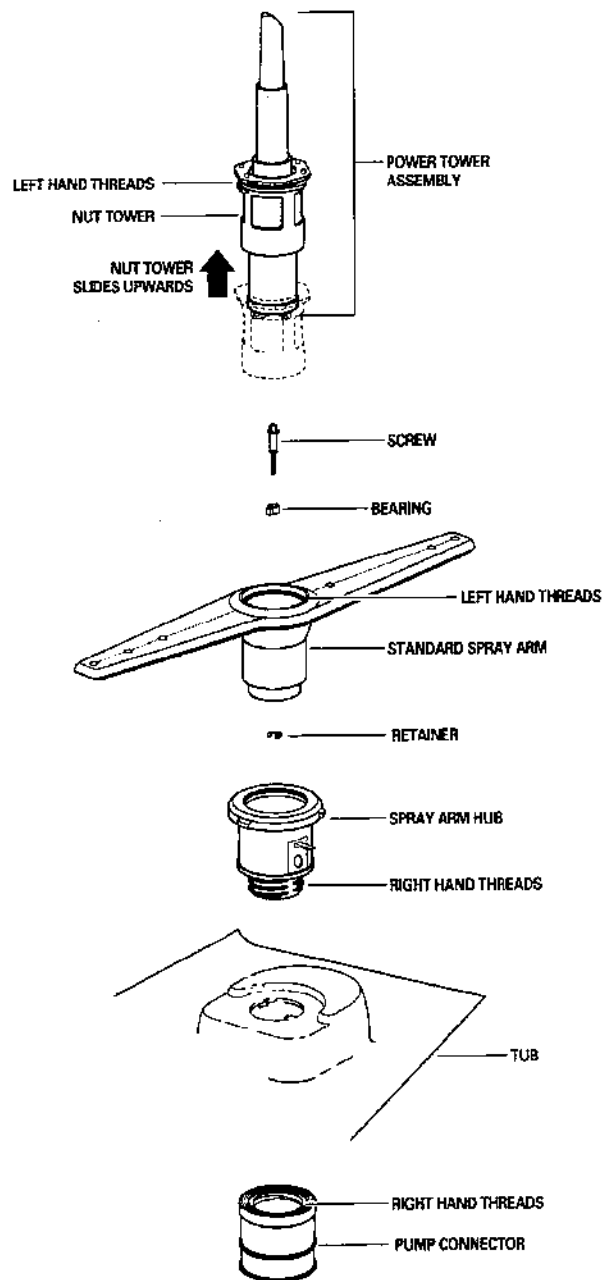



**WASH ARM SERVICE AND DISASSEMBLY:**

1. Check spray arm holes for bits of china, seeds and other foreign matter.
2. Check spray arm rotation.
3. Remove nut tower (illustration on the right) - LEFT HAND THREADS- by using a screwdriver-blade.
4. Lift out Power Tower assembly and Nut Tower.
5. Remove 1/4" hex head screw from the center of the wash arm to release arm.
6. Spray arm hub and entire spray arm assembly can be removed by turning spray arm hub (right hand threads) and removing.
7. Reverse to reassemble.

**LEFT HAND THREADS**

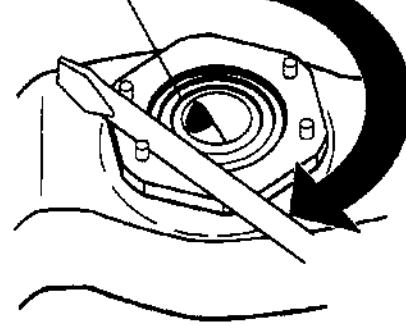

The illustration are right shows the parts that are common to both the Standard and the Whirlybird spray arm sytems. Parts that are interchangeable are:

- POWER TOWER ASSEMBLY
- SPLIT RING
- SCREW
- BEARING
- RETAINER
- SPRAY ARM HUB
- PUMP CONNECTOR

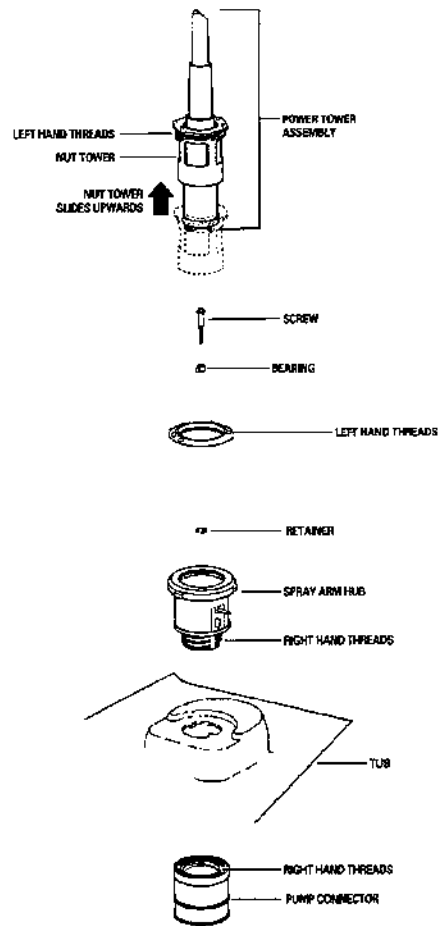



## CleanDesign DISHWASHER

The sump cover has been redesigned, although the operation is still the same.

### MOTOR STALLED-HUMS

1. Remove power. Try to turn fan blade clockwise to determine if seal is tuck and can be broken loose. If motor shaft can not be turned, cutter blade may be bound up. Proceed to step #2.
2. On inside of dishwasher, remove sump cover as shown on illustration at right. Remove the grid and reach down into the sump. Check for blockages such as bone, wire ties, etc. Check "pocket" on left side of sump; if it contains debris, clean thoroughly. If motor shaft cannot be turned, remove mechanism.

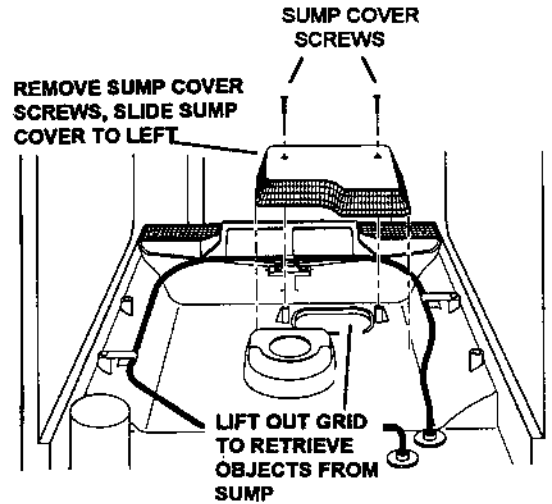

### AMOUNT OF WATER-CHECKING

Check level allowing dishwasher to fill normally for first fill. Measure the water level by standing a rule on the pedestal in the tub bottom center, just in front of the spray arm hub. The water level should be 3/8" to 1" high. If the water level is to low, check for clogged screen in water valve, and check float switch.

### CALROD REDESIGN

The illustrations to the right also show the new shape of the Calrods, to accommodate the new wash arm design. The Calrod supports have also been changed to a metal bracket type with 3 point mounting to prevent the Calrod from touching the inner door, sides or lower wash arm. Remove a 1/4" hex screw in the top of the Calrod brackets to remove. The rear support is also a 1/4" hex, with a pivot and hole to stabilize the bracket. The electro-mechanical CleanDesign models all have a 500 watt Calrod.

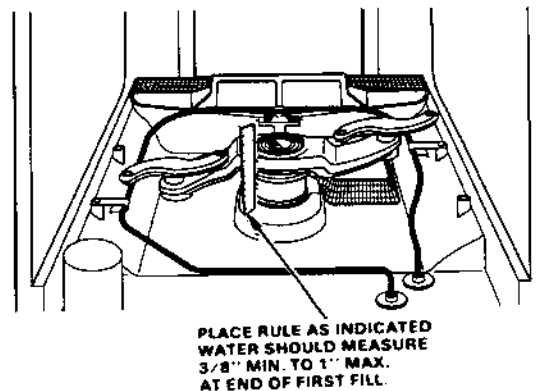

# CleanDesign DISHWASHER



The Low Travel Switch is an innovation that gives the look of a membrane type touch pad to pushbutton switches, and provides the "electronic" appearance to the electro-mechanical models. While the touch pad appears exactly like any other it does require a light push to activate the Low Travel Switch pushbutton.

Low Travel Switch pads are organized from the heavy wash cycles on the left to the lightest on the right. The Wash Heat Boost and Heated Dry options can be changed only by first touching the Options reset LT switch pad. Each Low Travel switch has an indicator light directly above it, which will stay on until the door latch is opened.

A rotary dial is used to start the dishwasher, as well as start time delay, and other cycles such as Short Wash, a rocker switch is used for Heated Dry on/off on some models.

(Note: The unit is shipped with a protective film on the etscutcheon. When removed without care it may bend the Lexan face which is bonded to an aluminum panel )

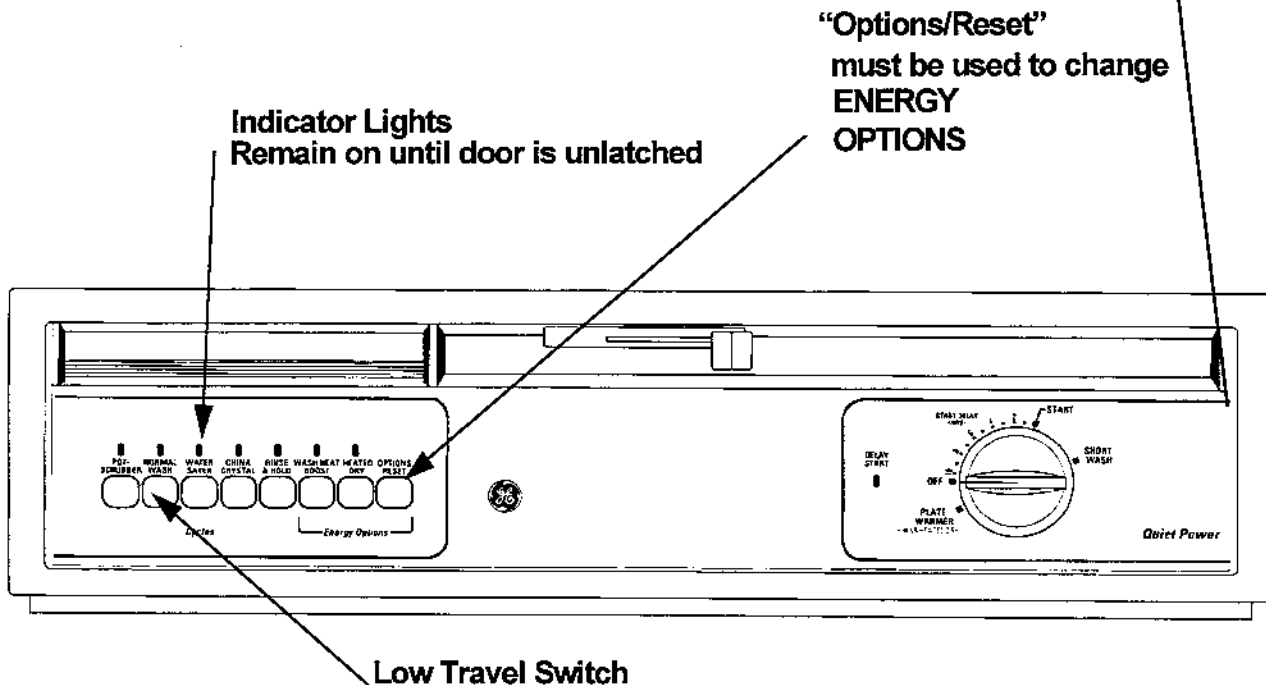





The inner door panel is separated as before with the exception that the door latch handle will now pass through the door panel opening without removal. The illustrations on the right show how to remove and service the Control Panel assembly. The timers are different since they have reduced times for fills and 1 less fill to accomplish reduced energy requirements..

## CONTROL PANEL ASSEMBLY

### TO SERVICE CONTROLS

1. Remove cover by lifting tab at each end.

### 2. SERVICING PUSHBUTTON SWITCH

A. Remove switch bracket assembly

B. Remove the necessary push buttons to remove the mounting screws.

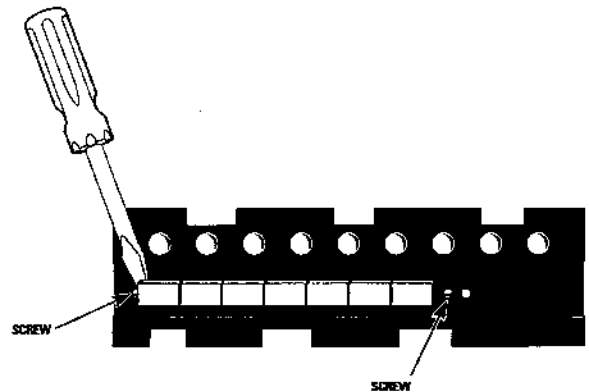
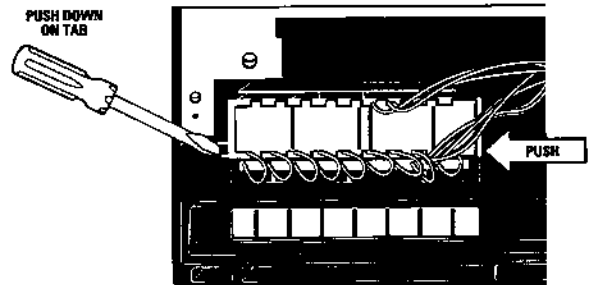
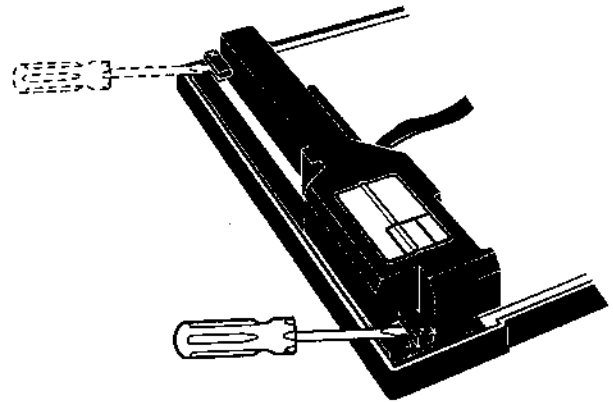



Some electro-mechanical CleanDesign models have Potscrubber cycle, and Wash Heat Boost option.

When the Potscrubber pushbutton is depressed on the control panel, contacts 19-20 are closed. This set up a circuit through timer switch contacts 5M-5B (that are closed during main wash) to terminal H1 on the Cycle Extender Switch. From H1 the circuit inside the extender is through a 5400 Ohm resistor, and through a normally closed set of switch contacts to terminal L2, which goes to the other side of the power supply.

The 5400 Ohm resistor heats up and causes the bi-metal switch contacts H2-L2 to open. When this happens, the timer motor circuit is opened, and the resistor circuit is also opened.

When the bi-metal switch cools down, the switch contacts H2-L2 reclose, and the timer starts running again, and the resistor heats up again. This action is repeated over and over until the timer motor moves the cam enough to open up timer switch contacts 5M-5B that supply power to H1.

The GSD1400T is a full featured electro-mechanical model and has Wash Heat Boost option and Potscrubber cycle. During the main wash cycle the Wash Heat Boost option operates when contacts 17-18 are closed. This sets up the circuit through timer switch contacts 7M-7B. This condition causes the extension of Potscrubber cycle by approximately 11 minutes, and other cycles by approximately 21 minutes.

**CYCLE EXTENDER SWITCH**

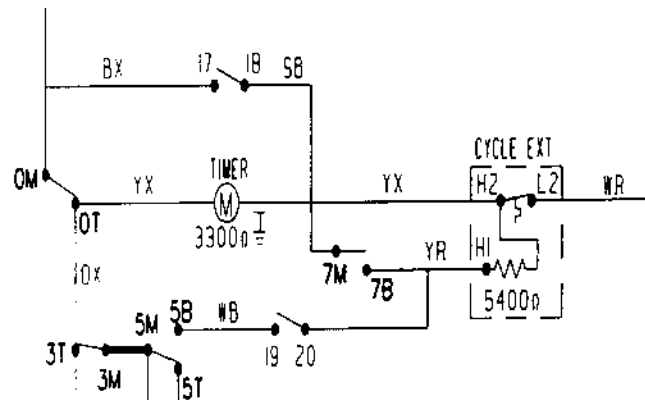
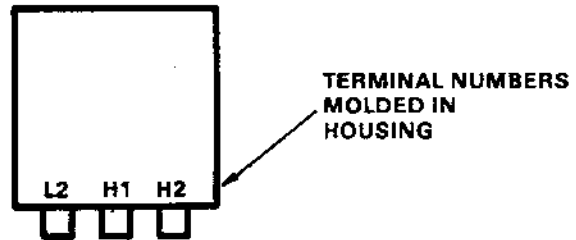



# CleanDesign DISHWASHER

Cycle extension for models other than the GSD1400S occurs in a similar manner. When Wash Heat Boost pushbutton is depressed on the control panel, contacts 9-10 are closed.

This sets up a circuit through timer switch contacts 4M-4B to terminal H1 on the cycle extender switch. From H1 the circuit inside the cycle extender switch is through a 5400 Ohm resistor, and through a normally closed set of switch contacts to terminal L2, which goes to the other side of the power supply.

The 5400 Ohm resistor heats up and causes the bi-metal switch contacts H2-L2 to open. When this happens, the timer motor circuit is opened, and the resistor circuit is also opened.

When the bi-metal switch cools down, the switch contacts H2-L2 reclose, and the timer starts running again, and the resistor heats up again. This action is repeated over and over until the timer motor moves the cam enough to open up timer switch contacts 4M-4B that supply power to H1. Selecting wash heat boost option will extend wash times of all cycles except Potscrubber and Rinse and Hold by approximately 21 minutes.

Water usage has been reduced by shortening fill times. (illustration below). The cam chart below shows that Potscrubber has 7 fills, which can be from 60 seconds to 42 seconds.

As an example the 1st fill in Potscrubber cycle is 60 seconds, while the initial fill on Short Wash cycle is actually fill #3 which is 53 seconds. The shortest fill time is 42 seconds and is less than any of our previous models.

WATER FILLS	
fill #	time/secs.
1	60
2	53
3	53
4	60
5	42
6	53
7	53

## CAM CHART/FILLS

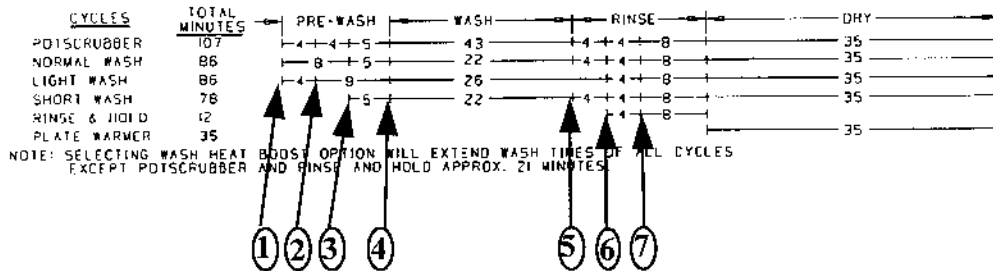
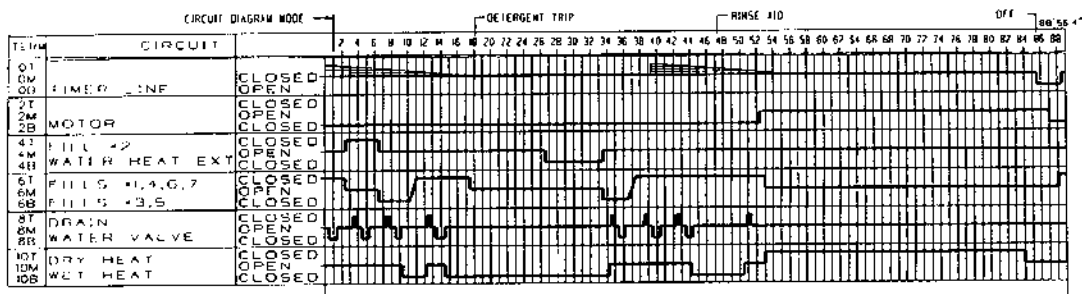

## NOTES

## NOTES