

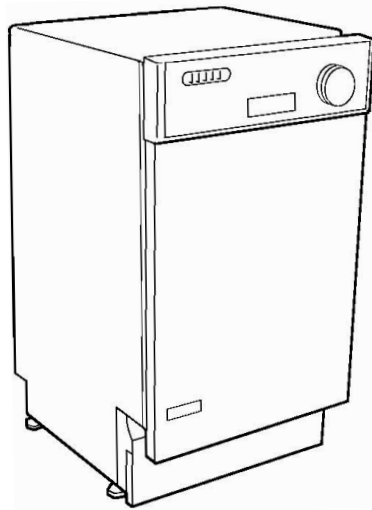

*GE Consumer & Industrial*

# TECHNICAL SERVICE GUIDE

## Monogram 18-In. Built-In Compact Dishwasher



**MODEL SERIES:**

**ZBD1800K**





### **IMPORTANT SAFETY NOTICE**

The information in this service guide is intended for use by individuals possessing adequate backgrounds of electrical, electronic, and mechanical experience. Any attempt to repair a major appliance may result in personal injury and property damage. The manufacturer or seller cannot be responsible for the interpretation of this information, nor can it assume any liability in connection with its use.

### **WARNING**

To avoid personal injury, disconnect power before servicing this product. If electrical power is required for diagnosis or test purposes, disconnect the power immediately after performing the necessary checks.

### **RECONNECT ALL GROUNDING DEVICES**

If grounding wires, screws, straps, clips, nuts, or washers used to complete a path to ground are removed for service, they must be returned to their original position and properly fastened.

***GE Consumer & Industrial***  
*Technical Service Guide*  
Copyright © 2004

All rights reserved. This service guide may not be reproduced in whole or in part, in any form, without written permission from the General Electric Company.

## TABLE OF CONTENTS

Bottom Door Seal .....	19
Component Locator Views .....	7
Control Panel Features .....	6
Detergent/Rinse Module .....	15
Dishwasher Components .....	10
Dishwasher Tub Seal .....	20
Door Assembly .....	17
Door Panel .....	14
Door Switch and Latch Assembly .....	12
Drain Pump Assembly .....	24
Fill Funnel .....	21
Heating Element .....	20
Illustrated Parts Catalog .....	40
Introduction .....	4
Motor Pump Assembly .....	25
Nomenclature .....	5
Pressure Switch .....	23
Schematic .....	39
Side Panels .....	16
Specifications .....	4
Static Dry System .....	13
Sump Assembly .....	27
Timer .....	10
Troubleshooting .....	29
Troubleshooting Checklist .....	34
Troubleshooting the Door Switch .....	29
Troubleshooting the Heating Element .....	30
Troubleshooting the Timer .....	31
Troubleshooting the Wash Pump Motor .....	32
Troubleshooting the Water Fill Valve .....	32
Warranty .....	46
Washability Complaints .....	38
Water Valve .....	22

# Introduction

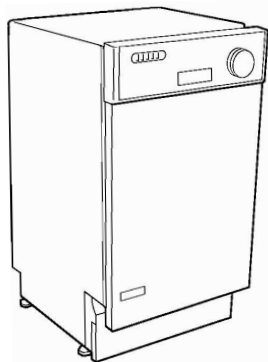

The new Monogram 18" Built-In Compact Dishwasher has a size that allows the unit to fit in areas as small as 18 inches (45.72 cm) wide, 22 inches (55.88 cm) long, and 34 inches (86.36 cm) high. It is compact in size, yet delivers the performance of larger units. With a low power usage, this product model meets ENERGY STAR® guidelines for energy efficiency.

The Monogram 18" Built-In Compact Dishwasher has two wash levels, a HEAVY WASH cycle, NORMAL WASH cycle, LIGHT WASH cycle, CHINA CRYSTAL cycle, and a RINSE ONLY cycle.

# Specifications

Electrical	
Rating	120 Volts, 60 Hz $\pm 10\%$
Separate Circuit	4.5 to 5.5 Amps
Motor (HP)	1/5
Motor (Amps)	1 $\pm 10\%$
Heater Wattage – Wash/Dry	465 $\pm 10\%$
Total Amps (Load Rated)	5 $\pm 10\%$

Component Resistance (OHMS)	
Timer Motor	1460 $\pm 10\%$
Heating Element	31 $\pm 5\%$
Pump Motor Windings	
Drain	27 $\pm 10\%$
Wash (Blue to Red)	47 $\pm 10\%$
Run Windings – Main (Blue to Black)	22 $\pm 10\%$
Water Valve Solenoid	1140 $\pm 5\%$
Total Amps (Load Rated)	5 $\pm 10\%$

Water Supply	
Suggested Minimum Incoming Water Temperature	120 °F to 150 °F (49 °C to 66 °C)
Sump Water Temperature With Outer Door In Place	145 °F $\pm 5$ °F (63 °C $\pm 3$ °C)
Water Charge	2.54 to 3.27 Quarts (2.4 to 3.1 Liters)
Pressure	20 Min./120 Max. (PSI) 138 Min./827 Max. (kPa)
Connection (NPT)	3/8 In. (0.95 cm)
Consumption (Total)	4.7 to 6.1 Gallons (17.8 to 23.1 Liters)
Water Valve Flow Rate (GPM)	1.8 $\pm 14\%$ (6.81 LPM $\pm 14\%$ )
Water Circulation Rate (GPM)	10 $\pm 10\%$ (37.85 LPM $\pm 10\%$ )
Water Fill Time (Seconds)	30 ( $\pm 1$ )

# Nomenclature

## Model Number

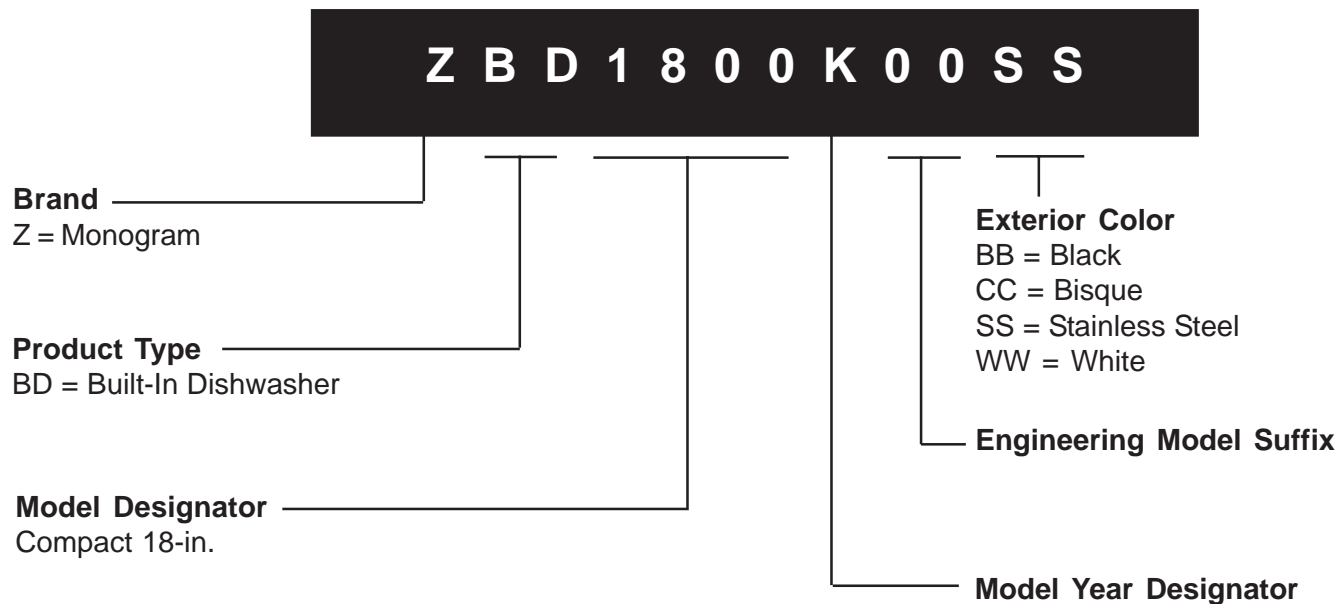

## Nomenclature

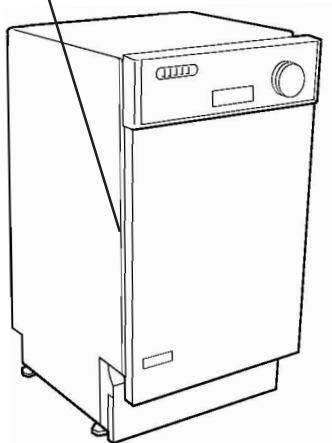

The serial plate of your dishwasher is located on the tub wall, just outside the door.

The service information sheet is located under the control panel.

## Serial Number

The first two characters of the serial number identify the month and year of manufacture.

Example: **AG**123456S = January, 2001

<b>A</b> - JAN	2005 - H
<b>D</b> - FEB	2004 - <b>G</b>
<b>F</b> - MAR	2003 - F
<b>G</b> - APR	2002 - D
<b>H</b> - MAY	2001 - A
<b>L</b> - JUN	2000 - Z
<b>M</b> - JUL	1999 - V
<b>R</b> - AUG	1998 - T
<b>S</b> - SEP	1997 - S
<b>T</b> - OCT	1996 - R
<b>V</b> - NOV	1995 - M
<b>Z</b> - DEC	1994 - L

The letter designating the year repeats every 12 years.

Example:

T = 1974  
T = 1986  
T = 1998

# Control Panel Features

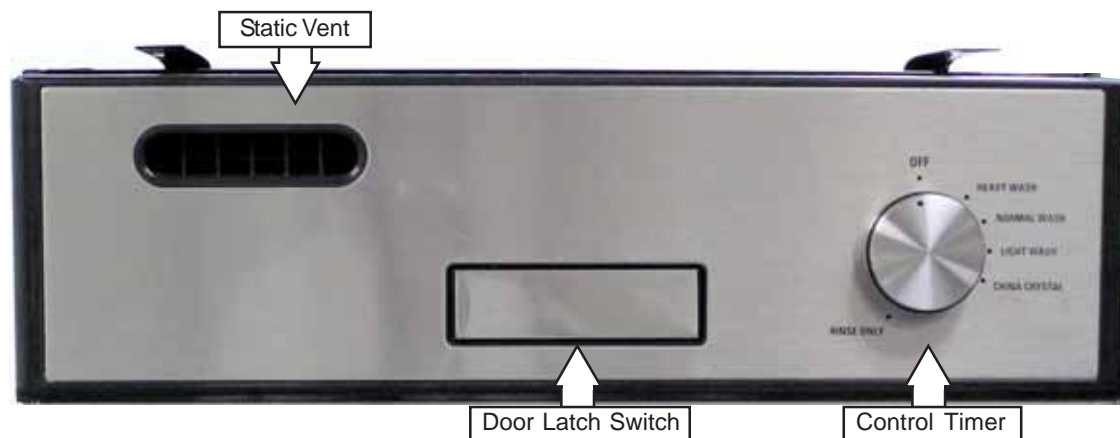

<b>Control Timer:</b>	
<b>START</b>	Close the dishwasher door and turn the control timer knob to the desired setting. Water fill begins and approximately 30 seconds later, the wash action begins.
<b>HEAVY WASH</b>	This cycle is for heavily soiled dishes and glassware.
<b>NORMAL WASH</b>	This cycle is for medium-soiled dishes and glassware.
<b>LIGHT WASH</b>	This cycle is for everyday dishes and glassware.
<b>CHINA CRYSTAL</b>	This cycle is specifically designed for lightly soiled china and crystal.
<b>RINSE ONLY</b>	For rinsing partial loads that will be washed later. Do not use detergent with this cycle.
<b>Door Latch Switch:</b>	Automatically shuts off the dishwasher whenever the dishwasher door is opened. The dishwasher will not resume operation until the door is closed.

# Component Locator Views

Front View



Control Panel View

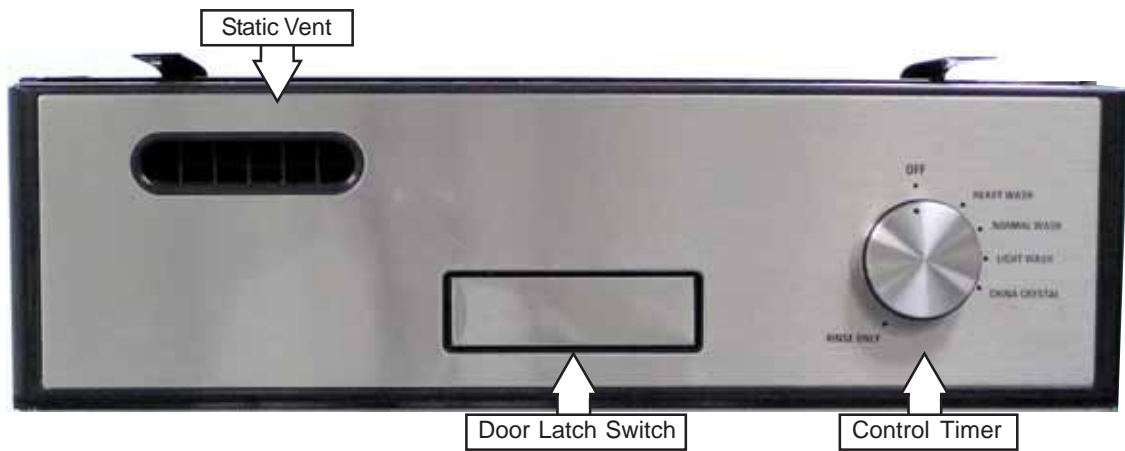

## Interior View (With Racks)

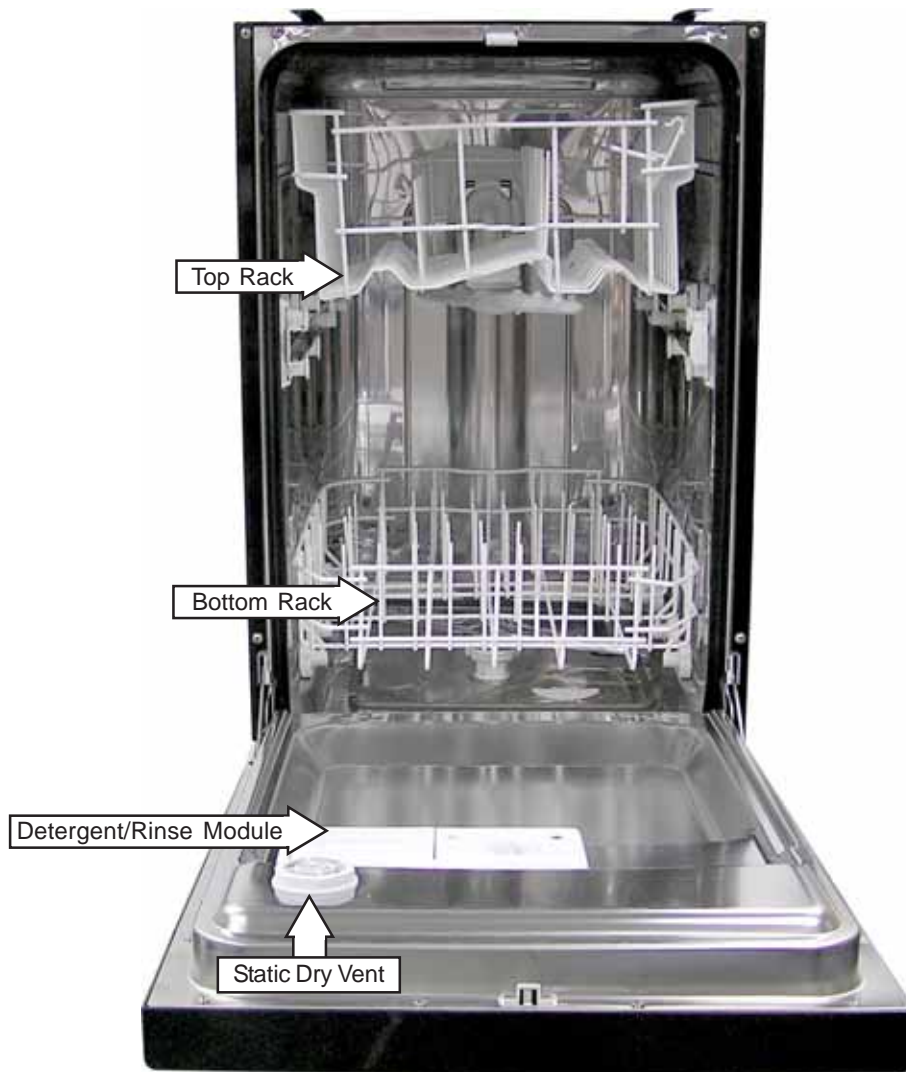

## Detergent/Rinse Module Compartment View

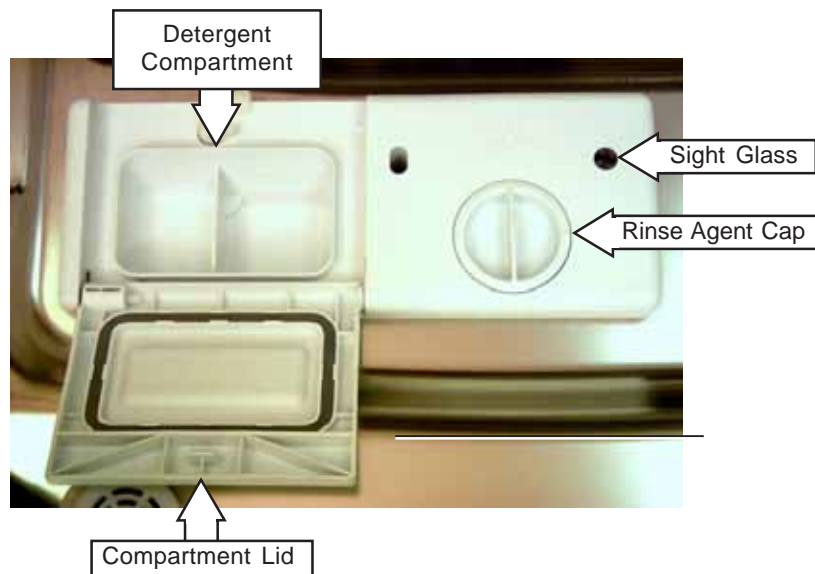



**Interior View of Basin (With Racks Removed)**



**Right Side View  
(Side Panel and Insulation Removed)**

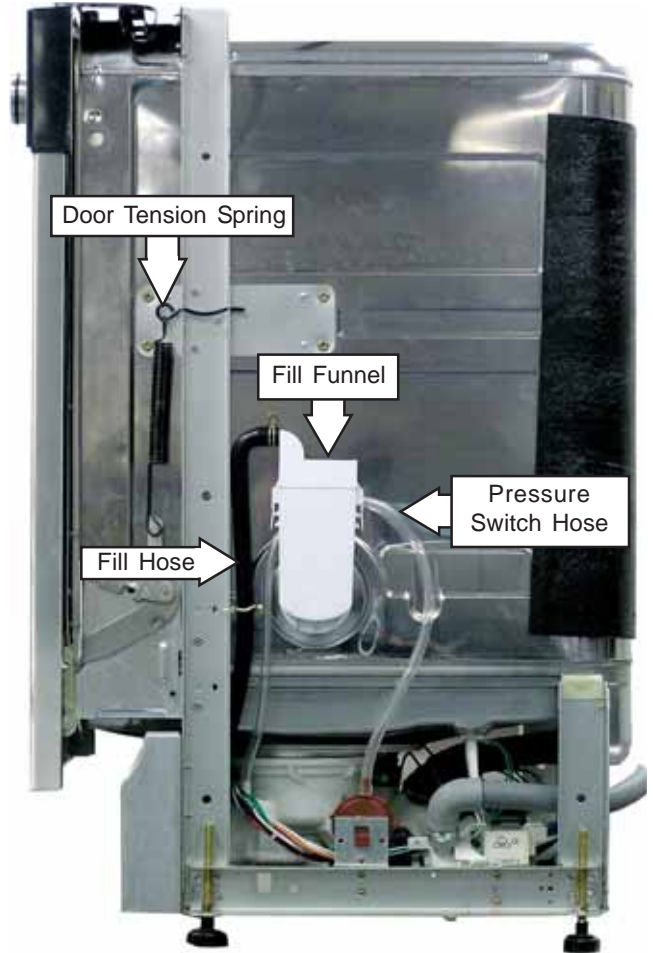

**Bottom View (Looking Up)**

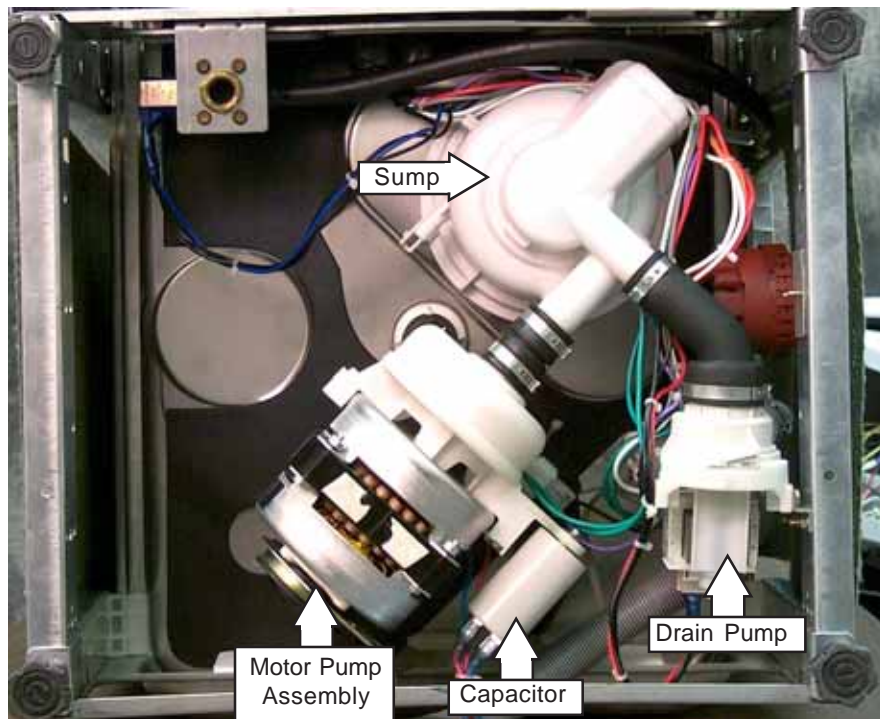

# Dishwasher Components

Throughout this manual, features and appearance may vary from your model.

## Timer

**WARNING:** Always turn off the electric power supply before servicing any electrical component, making ohmmeter checks, or replacing any parts.

**Note:** All voltage checks should be made with a voltmeter having a full-scale range of 130 volts or higher. After service is completed, be sure all safety grounding circuits are complete, all electrical connections are secure, and all access panels are in place.

The timer allows the user to select the various cleaning cycles of the dishwasher. The timer controls all stages of each cycle. All electrical functions can be traced on the charts and diagrams provided in this service manual.

## Removal and Installation

1. Disconnect the electric supply from the dishwasher.
2. Remove the control timer knob from the control panel cover.



3. Remove the top screw and mark the hole threads with a felt-tip marker.



Mark the inside of the hole threads with a felt-tip marker.



4. Remove the bottom screw and mark the hole threads with a felt-tip marker.
5. Open the dishwasher door.
6. Remove the 6 screws that connect the control panel cover to the dishwasher door.

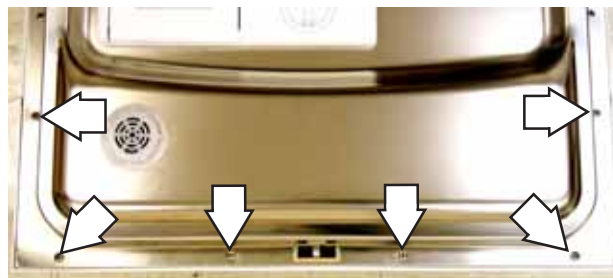

7. Close the dishwasher door.

8. Release the door latch and allow the control panel cover to hang against the dishwasher door.

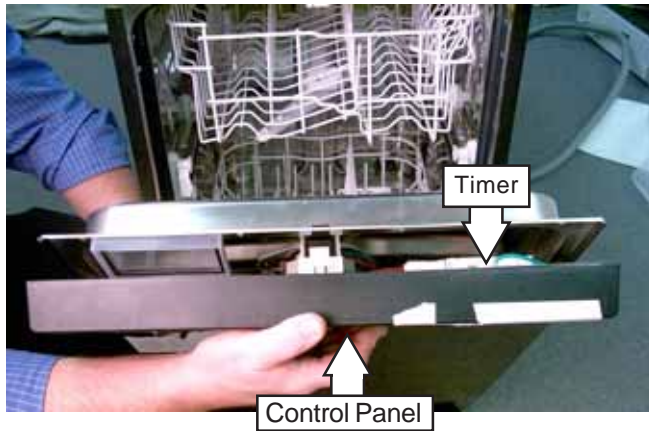

**Note:** When installing the timer, it is important to align the threaded holes (A) and (B), marked in steps 3 and 4, with holes (A) and (B) in the control panel

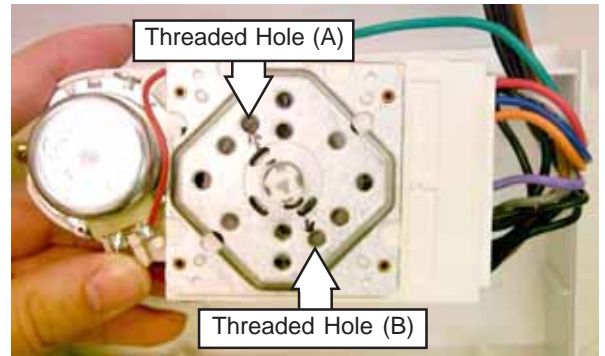

9. Disconnect the ground wire from the timer.
10. Disconnect the connectors. (Refer to mini-manual or schematic diagram on page 39 for reconnection.)

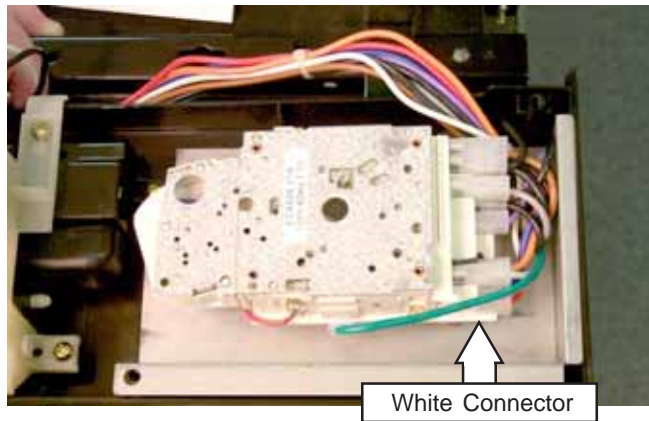

*Align the threaded holes marked in steps 3 and 4 with the holes in the control panel.*

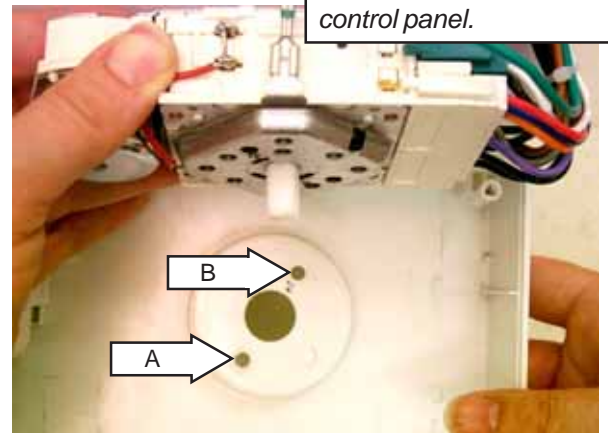

## Door Switch and Latch Assembly

The door switch and latch assembly is located on the door assembly behind the control panel cover. The dishwasher will not operate until the door is closed, the latch engages the door catch (holding the door firmly against the seal), and the normally open contacts of the double-pole, single-throw door safety switch are closed.

### Removal and Installation

1. Disconnect the electric supply from the dishwasher.
2. Open the dishwasher door.

**Caution:** Place a cloth or cardboard between the control panel and the dishwasher door to prevent marring the door.

3. Remove the 6 screws that connect the control panel cover to the dishwasher door. (See *Timer*, step 6.)
4. Close the dishwasher door.
5. Release the door latch and allow the control panel cover to hang against the dishwasher door.

**Note:** There are 6 terminals on the door switch. The top 2 terminals (1) and (2) are not used. The middle 2 terminals are marked (3) and (4). The bottom 2 terminals are marked (5) and (6).

6. Tag and disconnect the 4 wire terminals from the door switch.

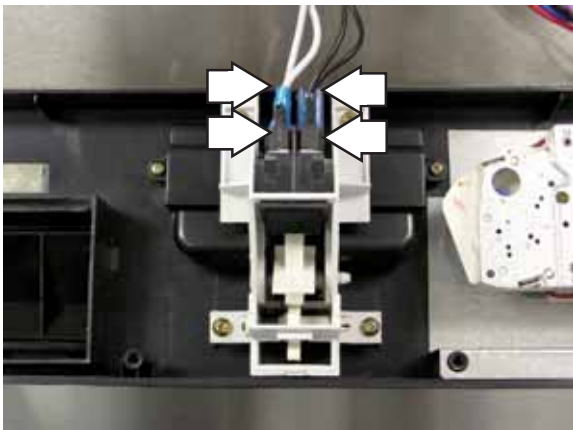

7. Remove the 4 screws that connect the door switch mounting bracket to the control panel cover.
8. Pull the door switch assembly down far enough so that the door latch cup clears the door latch mounting bracket.

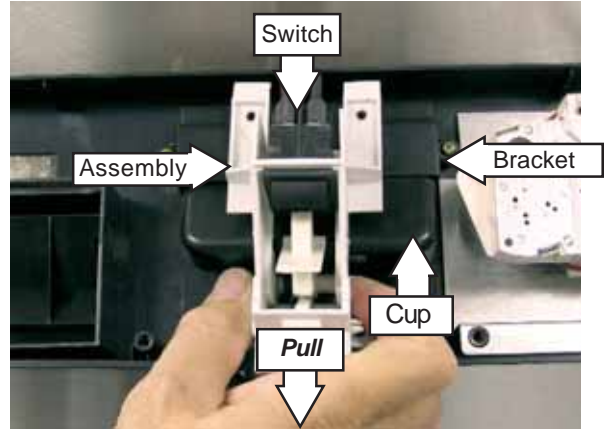

9. Remove the door switch from the door latch mounting bracket.
10. Inspect the door latch spring. Make sure the door latch flap fits properly in the door latch flap hole. If the spring is misaligned, broken, or missing, insert a new spring in the spring post holes.

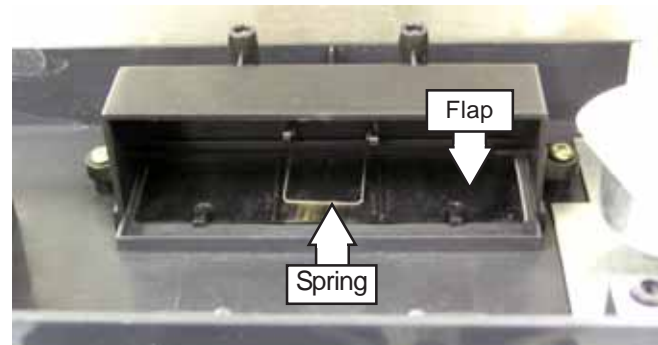

## Static Dry System

The static dry system operates through a vent located in the control panel. The vent allows hot air to exit the dishwasher tub and gradually remove moisture.

### Removal

1. Open the dishwasher door.
2. Remove the 6 screws that connect the control panel cover to the dishwasher door. (See **Timer**, step 6.)
3. Release the door latch and allow the control panel cover to hang against the dishwasher door.
4. Remove the static vent channel cover and assembly as shown below. Inspect the cover for hard water/lime deposits or debris, and clean if necessary.

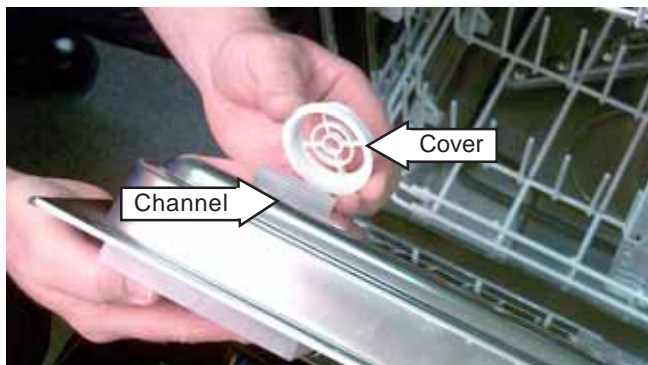

5. Inspect the o-ring. If the o-ring shows obvious signs of wear or damage, replace the channel assembly.



6. Inspect the gasket on the channel assembly. If the gasket shows obvious signs of wear or damage, replace the channel assembly.

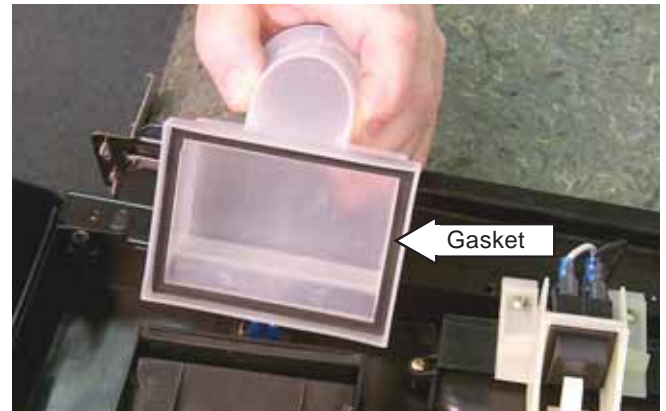

### Installation

1. Insert the static vent channel through the static vent door hole.

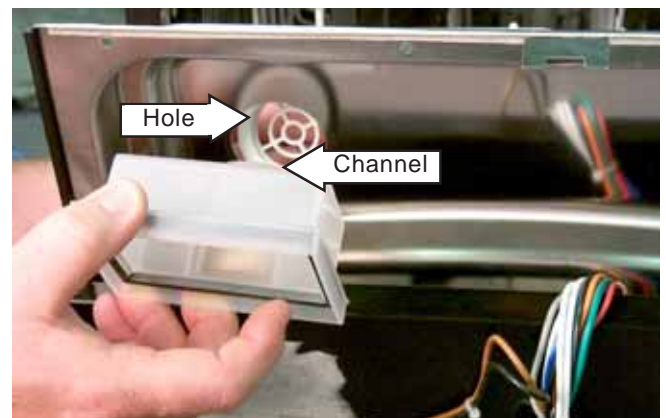

2. Install the static vent cover to the static vent channel, and position the control panel cover on the dishwasher door.

(Continued next page)

**Note:** Make sure the edge of the control panel cover is flush with the edge of the door.

3. Align the screw holes on the control panel with the screw holes on the dishwasher door.



4. Install the 6 screws that connect the control panel cover to the dishwasher door.

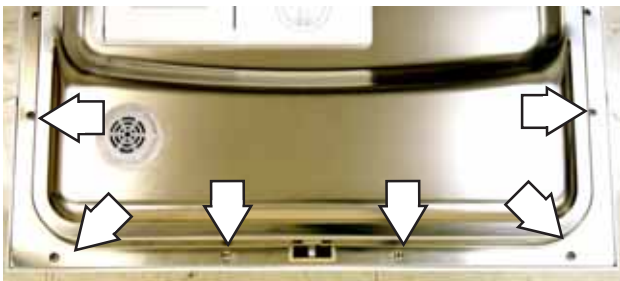

## Door Panel

The door panel covers the door to the dishwasher and protects the detergent/rinse module electronics.

### Removal

1. Disconnect the electric supply from the dishwasher.
2. Open the dishwasher door.
3. Remove the 6 screws and the door panel from the door assembly. Do not remove the 6 screws that hold the control panel cover to the door assembly.

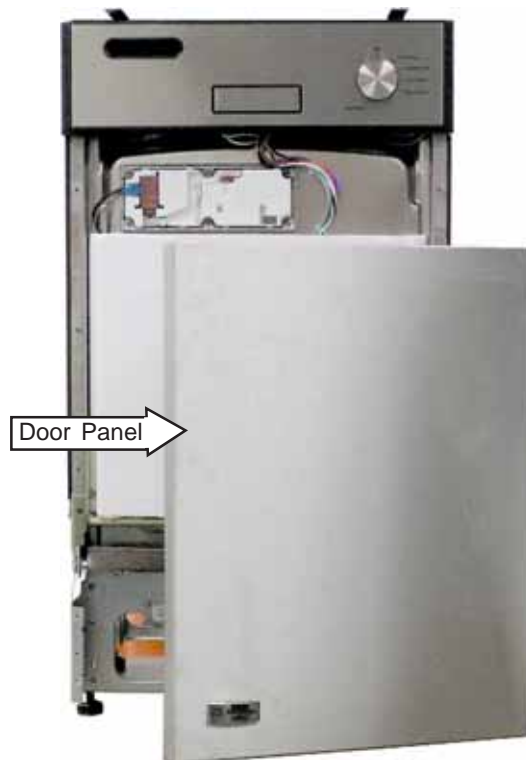

## Detergent/Rinse Module

The detergent rinse module automatically dispenses both the detergent and the rinse agent at the appropriate times. The module is activated twice during a wash cycle.

The first time the module is activated (1), the lever slides up the right-hand path of the connecting rod.

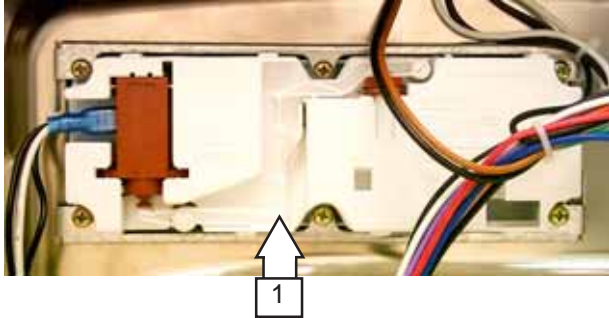

This action moves the cover catch (2) and releases the detergent cover.

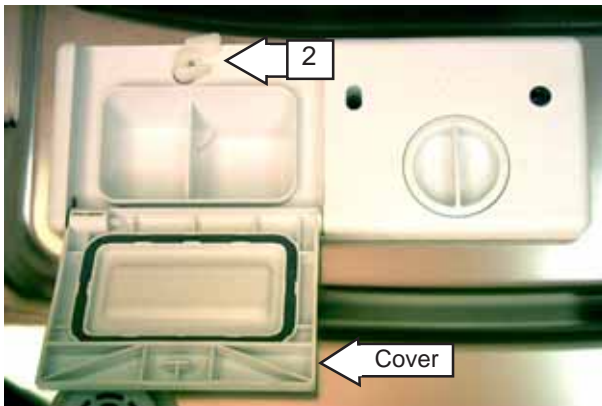

When deactivated (3), the lever resets to rest under the notch in the center of the connecting rod.

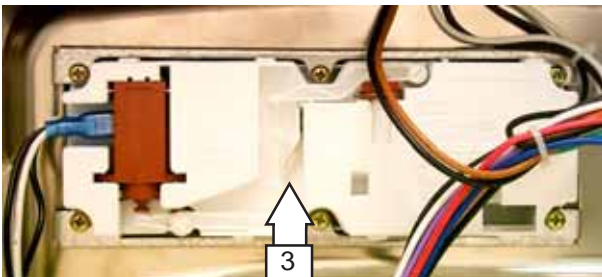

When activated for the second time in a cycle, the lever lifts the connecting rod by the notch, lifting the rinse dispenser plunger (4) and releasing the rinse agent. When deactivated, the lever returns to its original starting position.

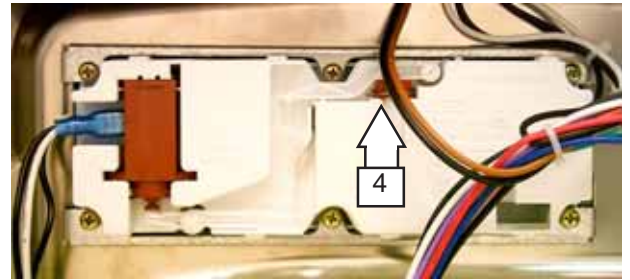

## Removal and Replacement

1. Disconnect the electric supply from the dishwasher.
2. Remove the **Door Panel**.
3. Remove the foam insulation.

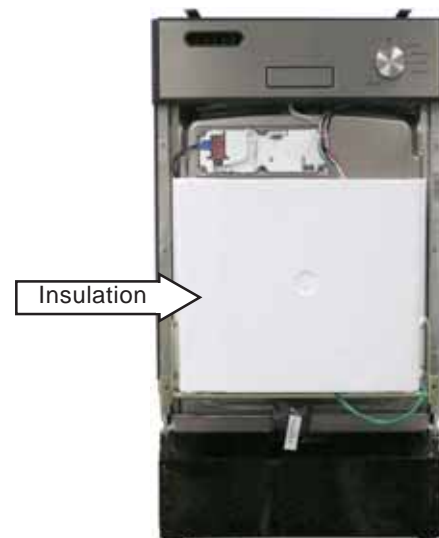

4. Disconnect the 2 terminals from the detergent/rinse module.



(Continued next page)

- Remove the 3 screws and top mounting bracket.

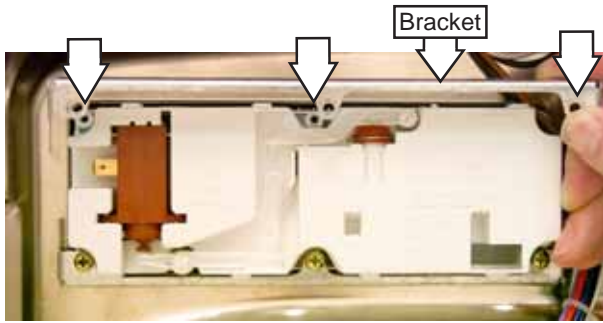

- Remove the 3 screws and bottom mounting bracket.

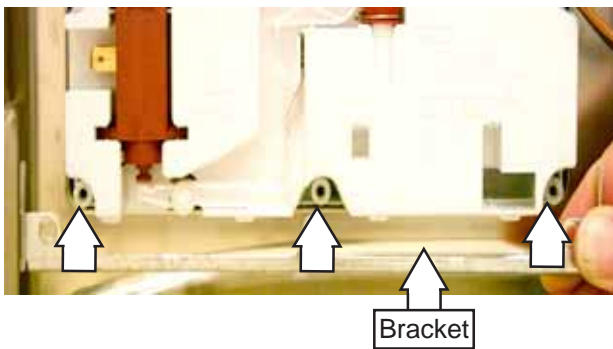

- Remove the detergent/rinse module from door assembly.

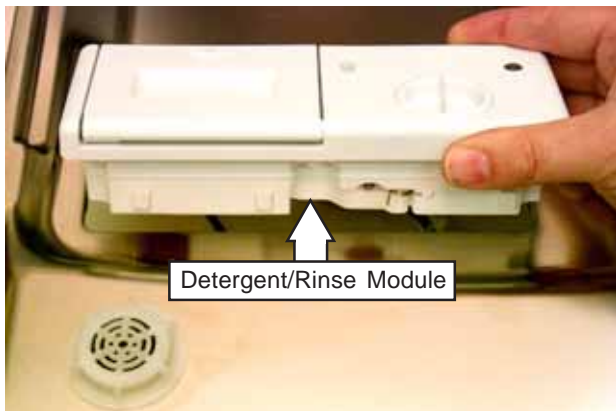

## Side Panels

### Removal

- Disconnect the electric supply from the dishwasher.
- Carefully pull the dishwasher out from its installation.
- Remove the screws from the top and back of each dishwasher side panel (16 screws total). Open the door and remove the 4 screws securing the panels to the inside door frame.

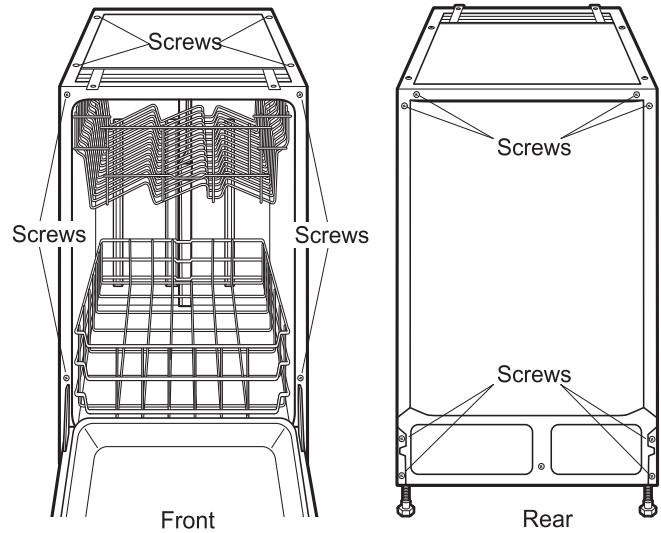

- Lay the dishwasher on its back. Remove the 4 screws securing the toekick to the dishwasher and remove the toekick.

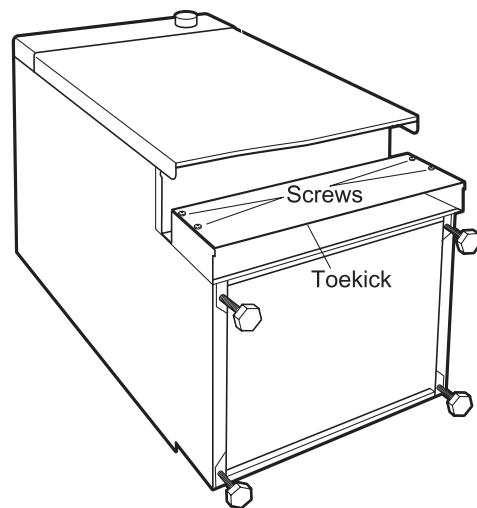



- Remove the single screw just above and to the side of each front leveling leg.

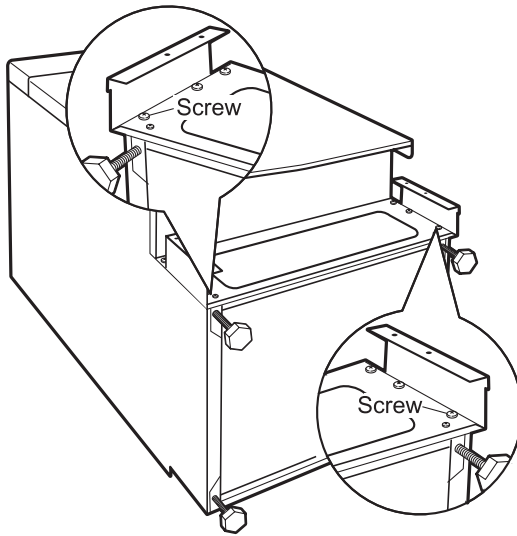

## Door Assembly

### Removal and Replacement

- Disconnect the electric supply from the dishwasher.
- Carefully pull the dishwasher out from its installation.
- Remove the 6 screws that connect the control panel cover to the dishwasher door. (See **Timer**, step 6.)
- Close the dishwasher door.

**Caution:** Place a cloth or cardboard between the control panel and the dishwasher door to prevent marring the door.

- Release the door latch and allow the control panel cover to hang against the dishwasher door.

- Disconnect the ground wire from the **Timer**.
- Disconnect the green and white multipin connectors from the **Timer**.
- Disconnect the 4 terminal lugs from the **Door Switch and Latch Assembly**.

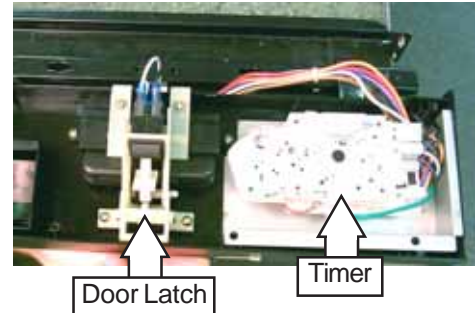

- Remove the **Door Panel**.
- Disconnect the 2 terminal lugs from the **Detergent/Rinse Module** switch.



- Remove the bolt, nut, and ground wire from the door.
- Pull the wire harness from the door.

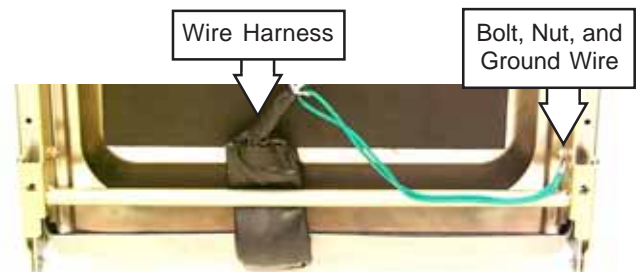

(Continued next page)

**Note:** There is a door hinge assembly on both the left and right sides of the dishwasher. Both door hinge assemblies must be removed in order to remove the door. The procedure to remove the right-side door hinge assembly is outlined in steps 13 through 24. The left-side door hinge assembly removal is identical.

13. Remove the 4 screws, access panel, and toe-kick panel from the dishwasher.
14. Remove the side panels. (See *Side Panels*.)
15. Mark the position of the spring bolt key in the mounting bracket with a felt-tip marker.

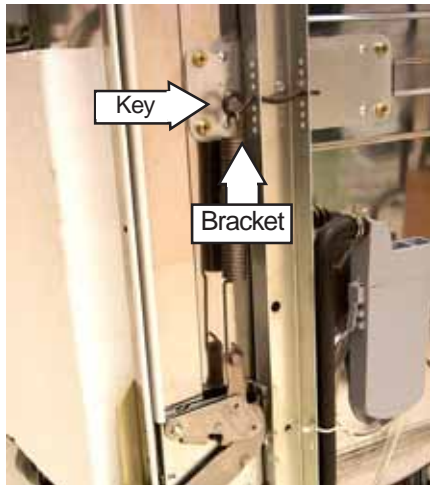

16. Pull the spring and spring bolt key from the mounting bracket.
17. Lift the bottom of the spring loop from the hinge arm stud.

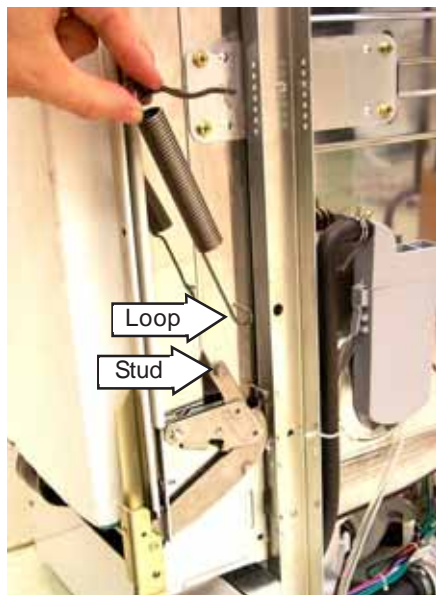

18. Open the dishwasher door approximately 30 degrees.
19. Lift the bottom hinge arm up from the bottom hinge, far enough to expose the hook.

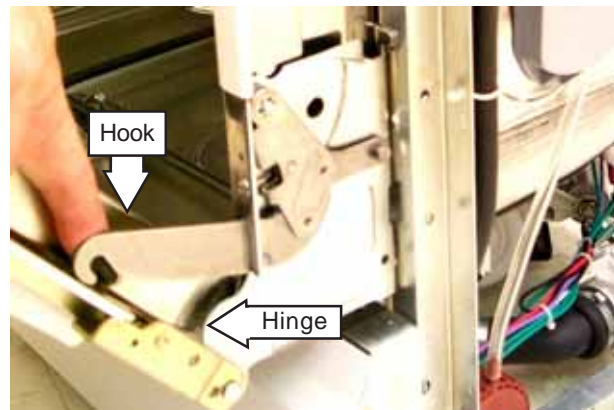
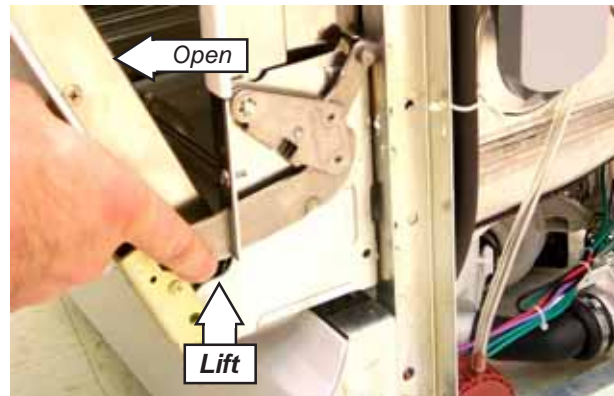

20. Close the dishwasher door.

**Caution:** The star washer is easily damaged during removal and should not be reused. Order a new set of star washers (part number: WD01X10254).

21. Remove the star washer from the dishwasher door hinge.

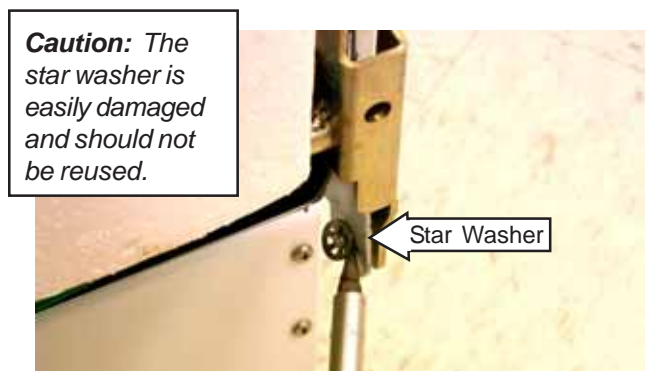

22. Remove the hinge pin from the dishwasher door hinge.

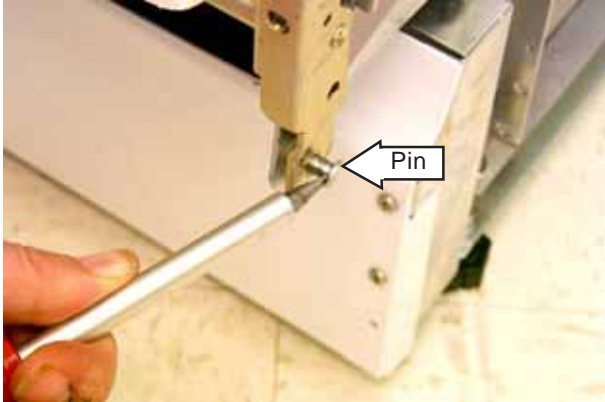

23. Repeat steps 15 through 22 to remove the left-side door hinge assembly.
24. Remove the dishwasher door from the dishwasher.

## Bottom Door Seal

The bottom door seal prevents water leakage. The seal is fitted in a pinched metal groove at the bottom of the dishwasher door.

### Removal and Replacement

1. Remove the **Door Panel**.
2. Remove the **Door Assembly** (steps 13 through 22 only).
3. Grab one end of the bottom door seal and peel it away from the pinched metal groove.

**WARNING:** The pinched metal groove is sharp. Wear Kevlar gloves when removing or installing the door seal. Failure to comply may result in personal injury.

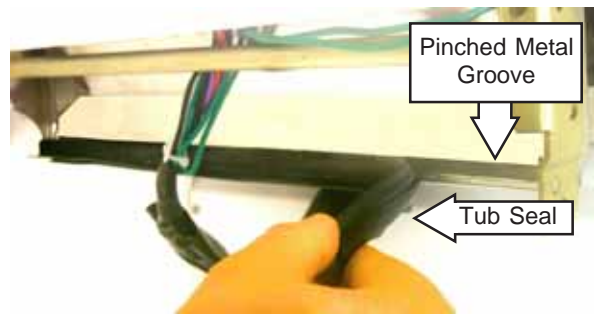

**Note:** When installing the door seal, make sure it is seated properly in the pinched metal groove. Run your finger over the groove to make sure it is smooth and even for a proper seal.

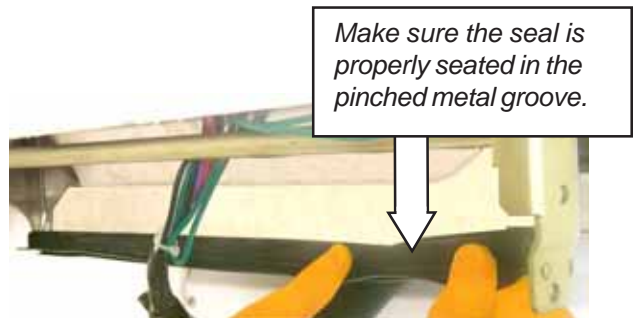

## Dishwasher Tub Seal

The dishwasher tub seal prevents water leakage. The seal is fitted in a seal channel that lines the rim of the dishwasher tub.

### Removal and Replacement

1. Open the dishwasher door.
2. Grab one end of the dishwasher tub seal and peel it away from the seal channel.



3. Reverse the above procedure to install.

**Note:** When installing the tub seal, make sure it is seated properly in the seal channel. Run your finger over the seal to make sure it is smooth and even for a proper seal. A correctly installed gasket will have both ends of the gasket equidistant from the bottom of the tub.

*Make sure the seal is seated properly in the seal channel.*



## Heating Element

The heating element maintains water temperature during the wash and rinse cycles and heats the air during the static dry cycle. (See **Specifications** for heating element wattage ratings.)

To check operation, advance timer to the dry cycle, set the selector switch for heated dry, and close and latch the dishwasher door. Allow one or two minutes before opening the dishwasher door and note if heat is present.

### Removal and Replacement

1. Disconnect the electric supply from the dishwasher.
2. Open the dishwasher door.
3. Remove the top and bottom dishwasher racks.
4. From underneath the dishwasher tub, locate the wires leading to the heating element.
5. Pull down the nylon covers, rubber wire protectors, and plastic strain reliefs from the wire terminals.

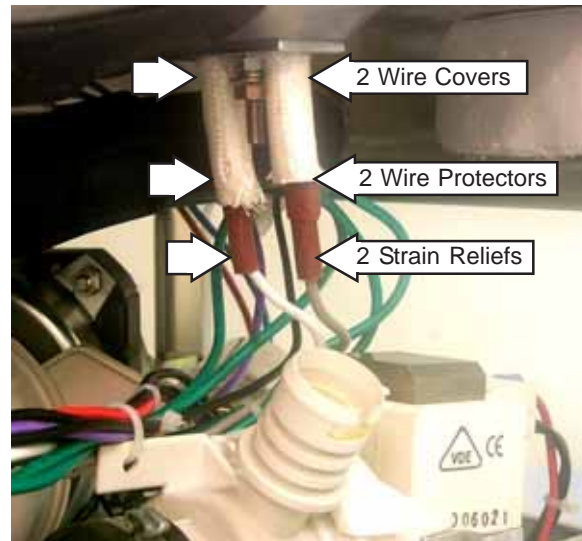

6. Disconnect the 2 terminal lugs from the heating element.

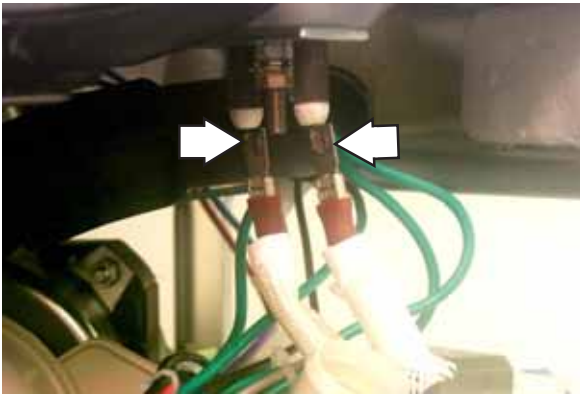

7. Remove the nut and ground wire.
8. Remove the lock-washer and spacer bracket.

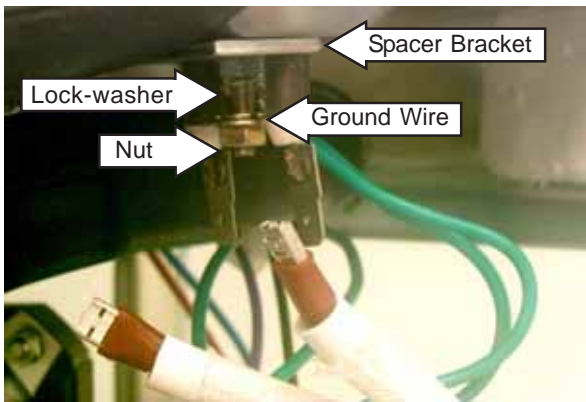

9. Release the 2 heating element clamps.

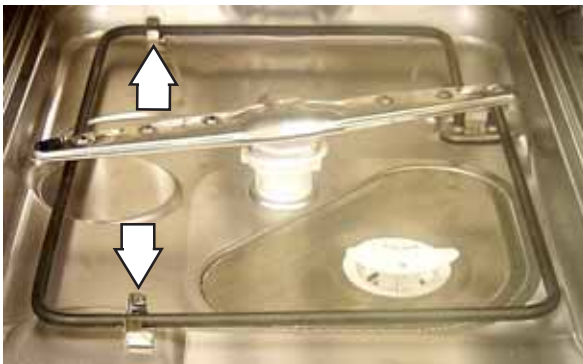

10. Lift up and remove the heating element from the dishwasher.

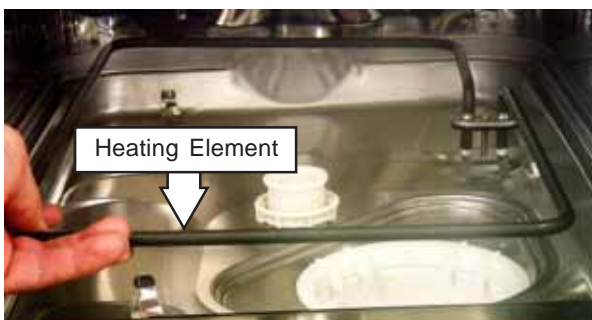

## Fill Funnel

The fill funnel is mounted on the left side of the tub. Its purpose is to provide a method of supplying water for the wash and rinse cycles. The air gap prevents the siphoning of wash water from flowing back into the water supply system, should the water pressure drop to less than atmospheric pressure. The fill funnel also allows air into the tub to permit air flow for dish drying.

## Removal and Replacement

1. Fold back the insulation surrounding the fill funnel and air gap assembly.
2. Open the dishwasher door.
3. Rotate the fill funnel cap counterclockwise and remove it from the fill funnel threads.



4. Loosen the clamp, disconnect the fill funnel hose, and remove the fill funnel.

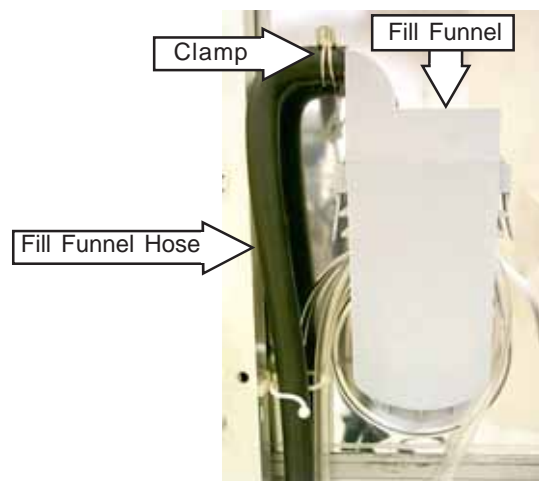

**Note:** Make sure that the clear plastic air tube is looped around that part of the fill funnel that protrudes into the dishwasher tub and mates with the fill funnel cap.

## Water Valve

The water valve is timer controlled and solenoid operated. The flow of water is controlled by a rubber flow washer capable of maintaining a flow rate of  $1.8 \pm 14\%$  gallons per minute ( $6.81 \pm 14\%$  liters per minute) with incoming water pressure of 20 to 120 PSI. The water valve is mounted to the left hinge support of the dishwasher.

### Removal and Replacement

1. Disconnect the electric supply from the dishwasher.
2. Remove the 4 screws, access panel, and toe-kick panel from the dishwasher.

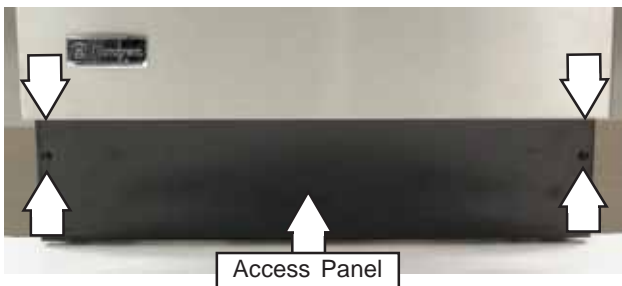

*Shown with access panel removed.*

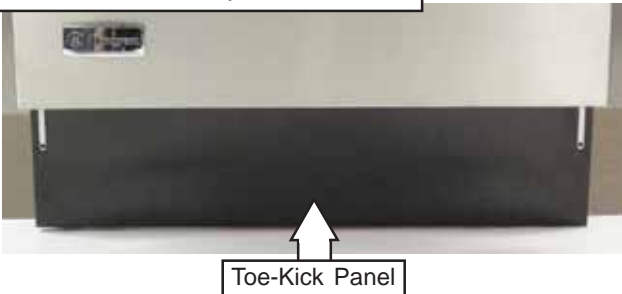

3. Disconnect the incoming water line from the water fill valve port.
4. Remove the 2 screws and mounting bracket from the dishwasher.

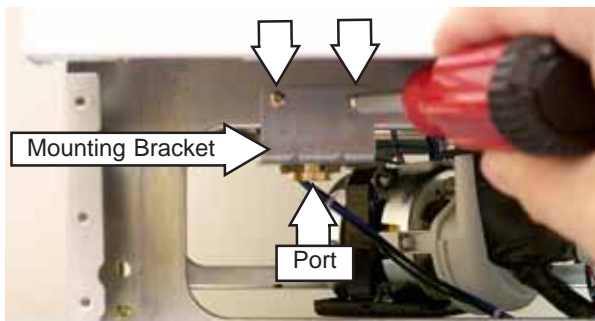

*Shown with water line removed.*

5. Remove the clamp and disconnect the tub fill hose from the water valve assembly.

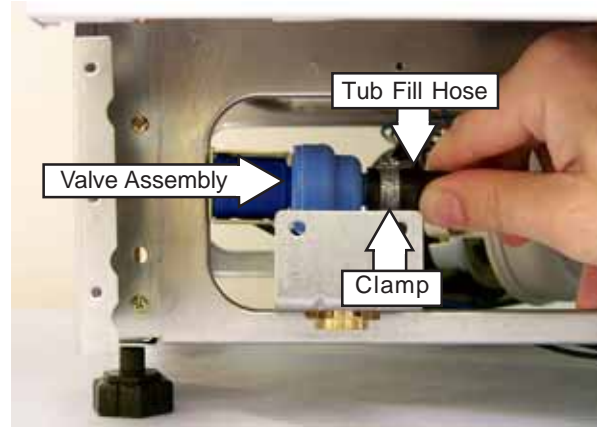

6. Disconnect the 2 terminal lugs from the water fill valve assembly.

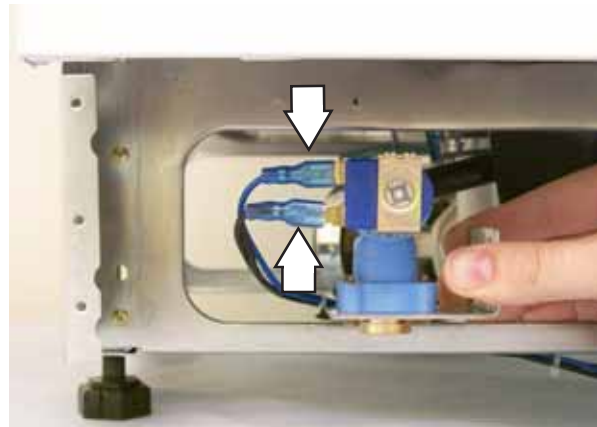

7. Remove the 4 screws and water fill valve from the mounting bracket. Retain the mounting bracket and screws.

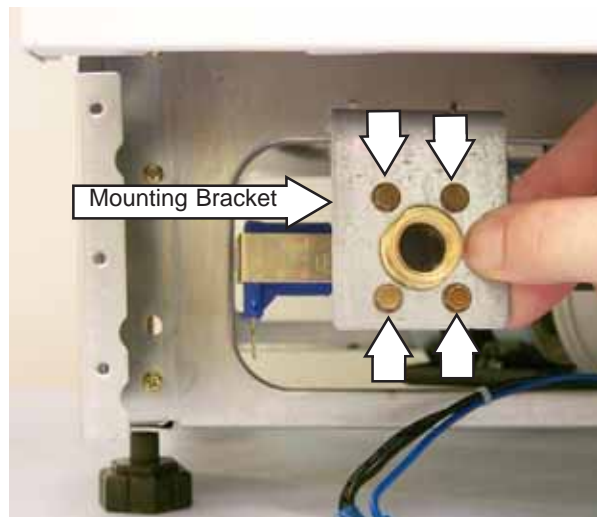

## Pressure Switch

The pressure switch is located under the tub at the right front corner. A clear plastic tube, the pressure switch hose, runs from the float switch, around the fill funnel, and to the sump.

As the dishwasher basin fills with water, the air pressure in the pressure switch hose increases. Normally, the timer regulates the amount of time the water fill valve remains open. If the water fill valve remains energized, the overfilling of the basin increases the air pressure in the pressure switch hose, causing the pressure switch to open the circuit to the timer motor and closing the circuit to the drain pump. The drain pump then empties the water in the sump.

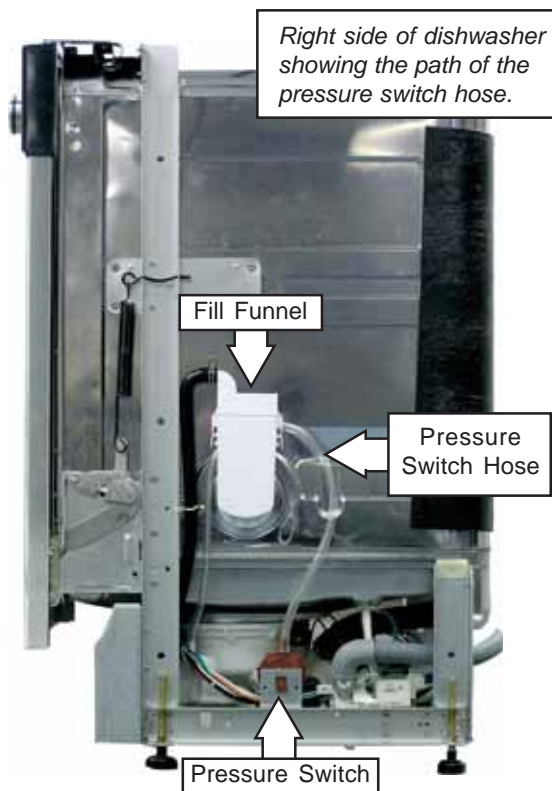

### Removal and Replacement

1. Disconnect the electric supply from the dishwasher.
2. Carefully pull the dishwasher out from its installation.
3. Remove the 4 screws, access panel, and toe-kick panel from the dishwasher.
4. Remove the 10 screws and the right side panel.

5. Remove the capillary tube from the float switch.

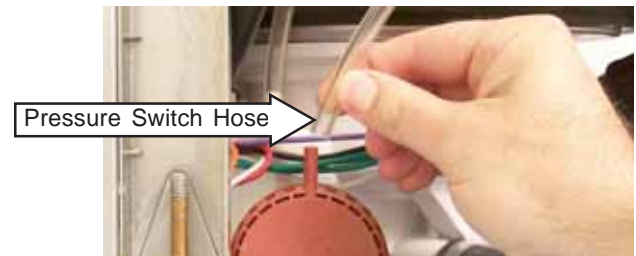

6. Turn the float switch clockwise to align the mounting tab vertically with the mounting hole, and remove the float switch from the dishwasher frame.

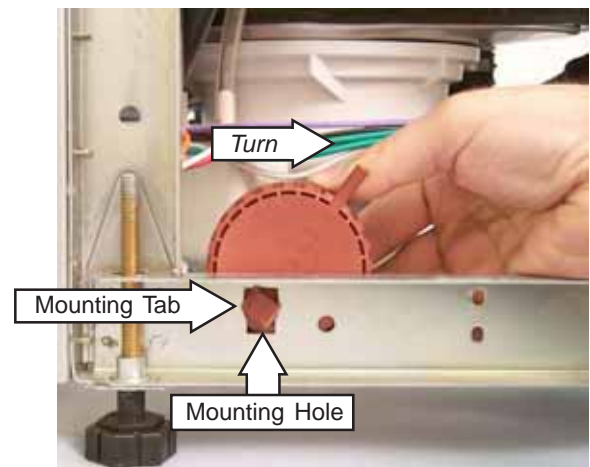

7. Label and disconnect the 3 terminal lugs from the float switch, and remove the float switch.

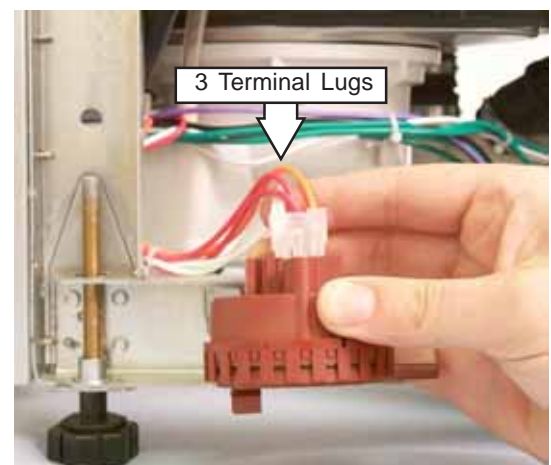

## Drain Pump Assembly

The drain pump assembly is located under the tub at the right rear corner. The drain pump operates on 120 VAC and is energized 60 seconds after the wash pump shuts down, to remove any water in the dishwasher sump. The drain pump forces the water out the drain line. A check valve flapper on the drain pump prevents the dirty water from reentering the sump.

### Removal and Replacement

1. Disconnect the electric supply from the dishwasher.
2. Carefully pull the dishwasher out from its installation.
3. Remove the 4 screws, access panel, and toe-kick panel from the dishwasher.
4. Remove the 10 screws and the right side panel.
5. Remove the drain tube (not shown) from the drain pump port.

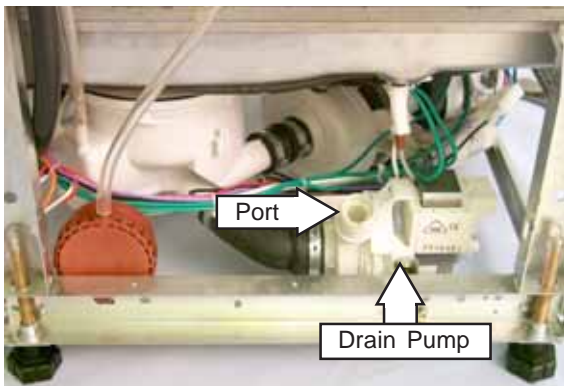

6. Label and disconnect the 2 terminal lugs from the drain pump.

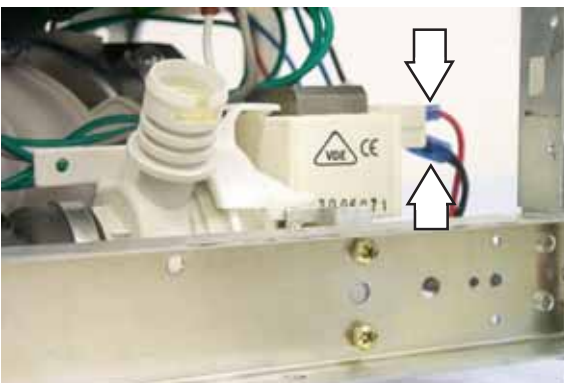

5. Remove the 2 bolts, lock-washers, and nuts.

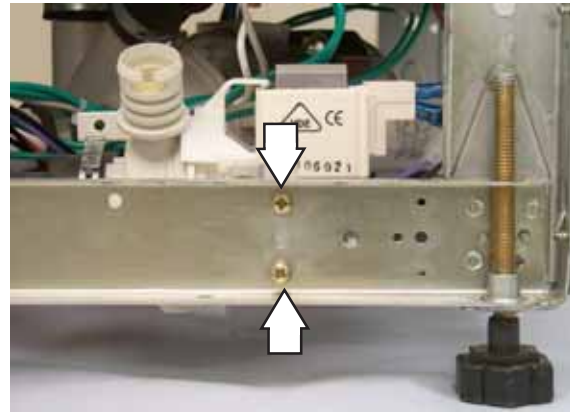

**Caution:** The clamp is easily damaged during removal and should not be reused. Replace the old clamp with a new universal clamp (part number: WH1X2036).

6. Remove the clamp from the sump interconnect hose.
7. Remove the drain pump from the sump interconnect hose.

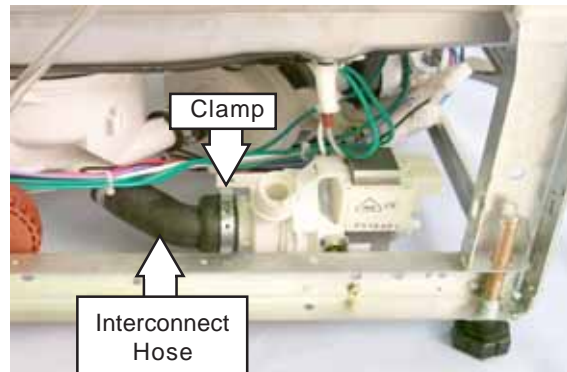

8. Remove and save the 2 screws, lock-washers, mounting bracket, and nut plate from the drain pump.

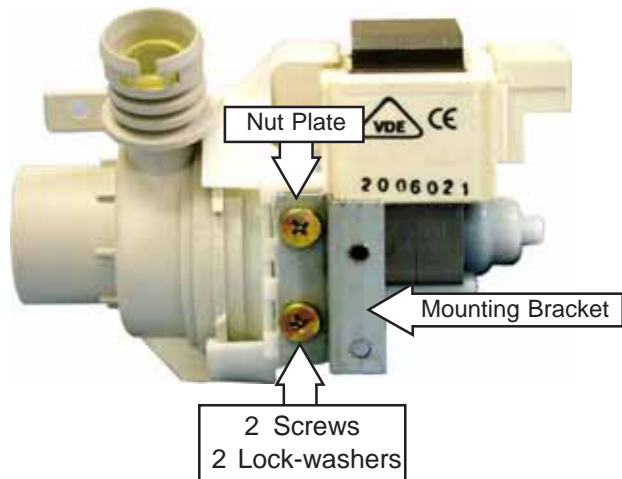



## Motor Pump Assembly

The motor pump assembly is located under the tub behind the sump assembly. This dishwasher model uses a capacitor start induction motor. The motor rotates clockwise (as viewed from the terminal end) and draws approximately 1 amp ( $\pm 10\%$ ) at 120 VAC ( $\pm 10\%$ ).

### Removal and Replacement

1. Disconnect power.
2. Carefully pull the dishwasher out far enough from its installation to access the drain pump from the rear of the dishwasher.
3. Label and disconnect the 2 terminals to the capacitor.

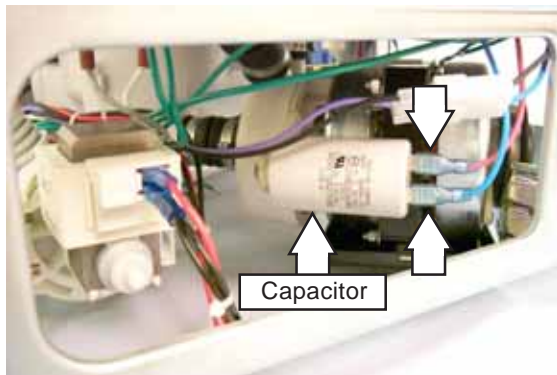

4. Label and disconnect the 2 terminals to the motor wire connector.

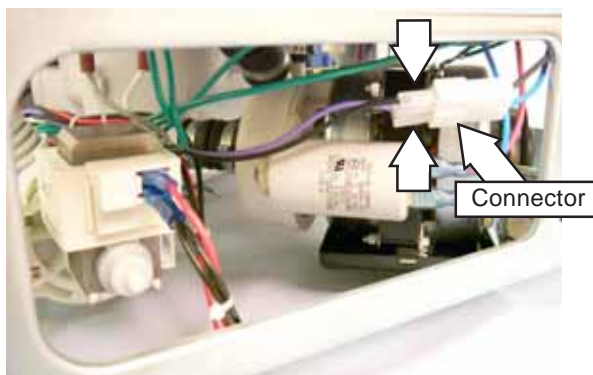

**Caution:** The clamp is easily damaged during removal and should not be reused. Replace the old clamp with a new universal clamp (part number: WH1X2036).

5. Remove the clamp from the motor sump interconnect hose.

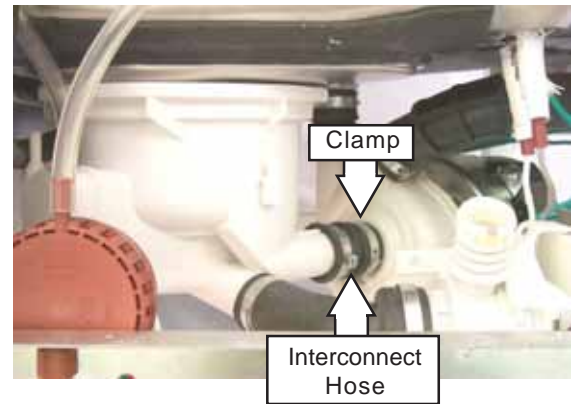

**Caution:** The clamp is easily damaged during removal and should not be reused. Replace the old clamp with a new universal clamp (part number: WH1X2036).

6. Remove the clamp from the motor main conduit interconnect hose.

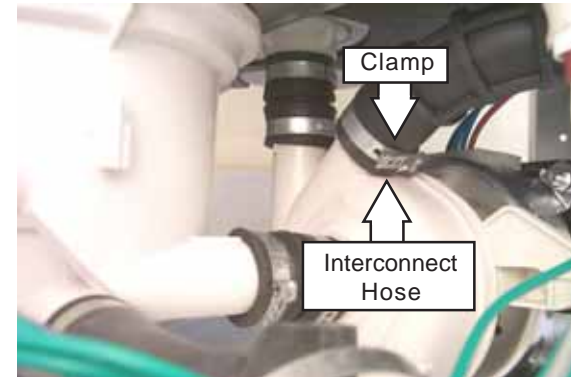

**Caution:** The clamp is easily damaged during removal and should not be reused. Replace the old clamp with a new universal clamp (part number: WH1X2036).

7. Remove the clamp from the motor washer arm interconnect hose.

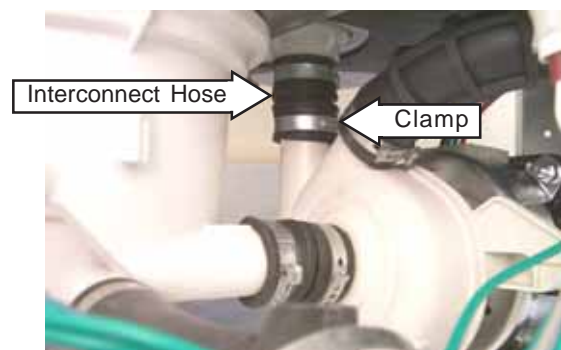

**Note:** Do not attempt to remove the bolt and locknut that connect the motor mount to the dishwasher frame.

*(Continued next page)*

8. Remove the screw and disconnect the ground wire from the wash pump motor assembly.

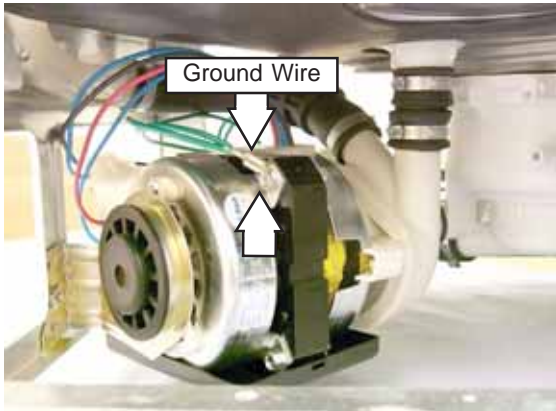

As seen from rear of dishwasher.

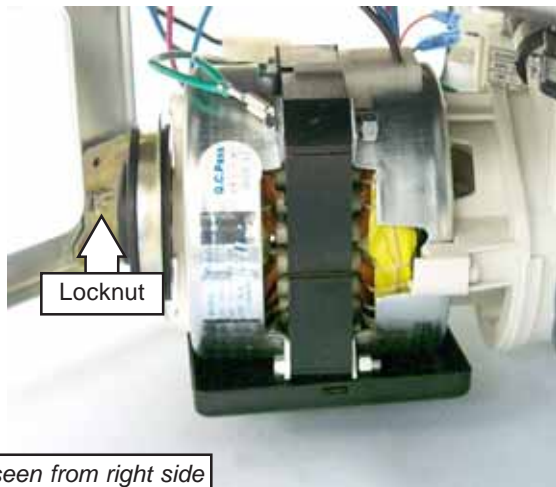
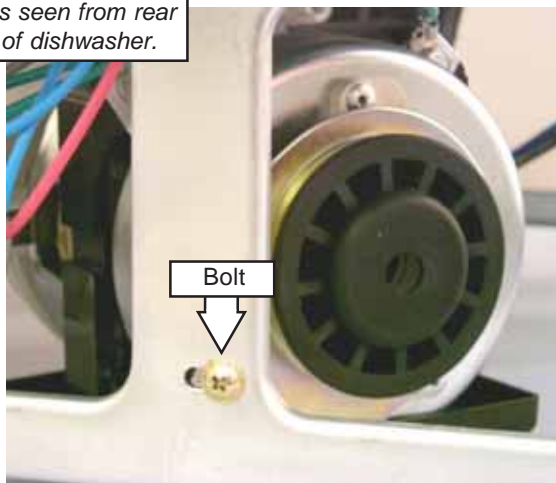

As seen from right side of dishwasher.

9. Pull the motor mount back far enough to clear the motor tab, work the motor from the attaching hoses, and remove the motor pump assembly from the dishwasher.

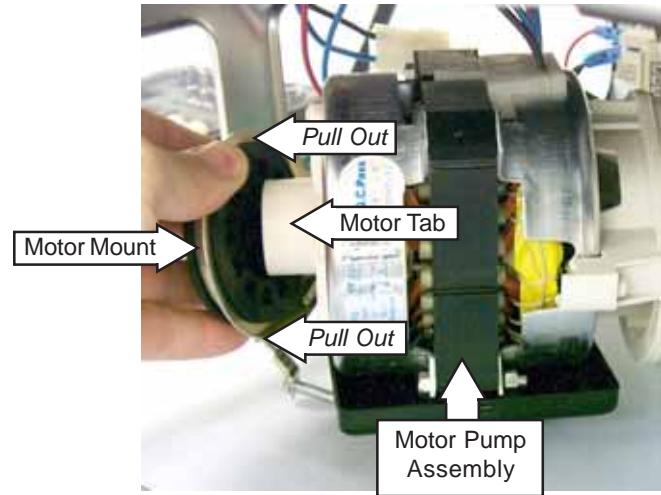

## Sump Assembly

The sump assembly consists of the filter assembly, micro-filter, sump clamping nut, sump gasket, and sump. The filter assembly prevents large particles from reaching the micro-filter, and the micro-filter prevents small particles from reaching the sump. The filter assembly rests above the sump and the micro-filter sits above the sump basin. The clamping nut holds the sump gasket and sump to the bottom of the dishwasher. The filter assembly, microfilter, and sump clamping nut are accessed from inside the dishwasher. The sump gasket and sump are located under the tub in front of the motor pump assembly.

### Removal and Replacement

1. Disconnect power.
2. Carefully pull the dishwasher out from its installation.
3. Remove the 4 screws, access panel, and toe-kick panel from the dishwasher.
4. Remove the 10 screws and the right side panel.
5. Remove the high-pressure switch hose from the sump.

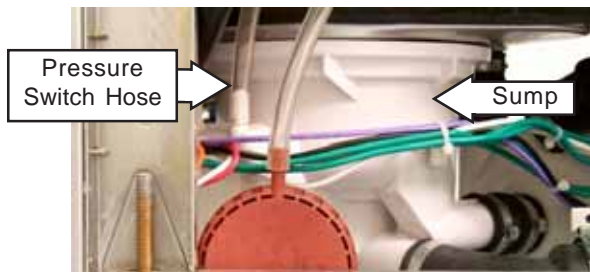

6. Remove the clamp from the interconnect hose that connects the sump to the wash pump motor.

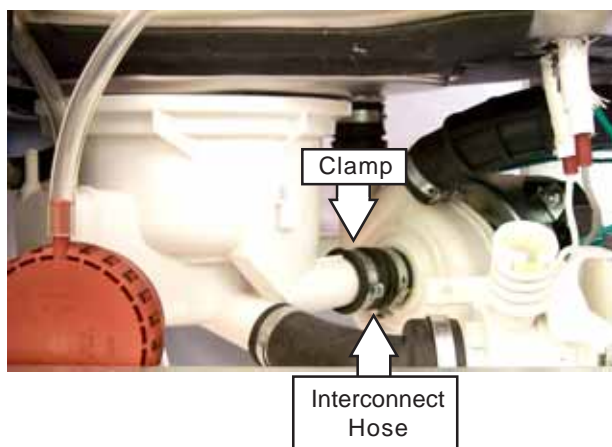

7. Remove the clamp from the hose that connects the sump to the drain pump assembly.

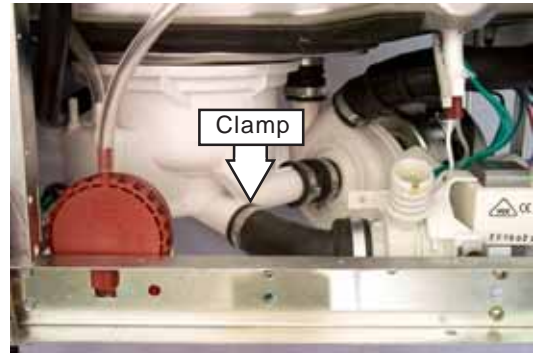

8. Open the dishwasher door and remove the bottom rack (not shown).
9. Remove the filter assembly.

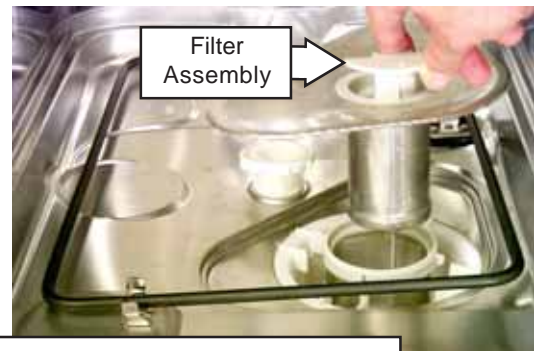

*Shown with washer arm removed.*

10. Remove the microfilter.



*Shown with washer arm removed.*

*(Continued next page)*

**Note:** The sump clamping nut turns counterclockwise and may be difficult to remove. It may be necessary to insert a screw driver or other tool between the clamping nut tabs to enable you to apply sufficient torque to break the factory seal.

11. Remove the clamping nut.

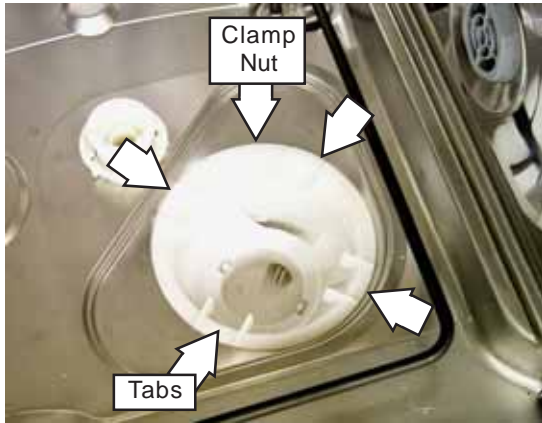

12. Remove the sump gasket (not shown) and sump.

# Troubleshooting

**WARNING:** Always turn off the electric power supply before servicing any electrical component, making ohmmeter checks, or replacing any parts.

**Note:** All voltage checks should be made with a voltmeter having a full-scale range of 130 volts or higher. After service is completed, be sure all safety grounding circuits are complete, all electrical connections are secure, and all access panels are in place.

## Troubleshooting the Door Switch

The door switch can be tested using an ohmmeter and the strip circuit.

1. Disconnect the electric supply from the dishwasher.
2. Remove the wire leads from the door switch.
3. Use an ohmmeter to check the door switch for continuity.
4. If the door switch is defective, remove it from the latch assembly. If the door switch is good, check to see if the timer is defective.

## Door Switch Strip Circuit

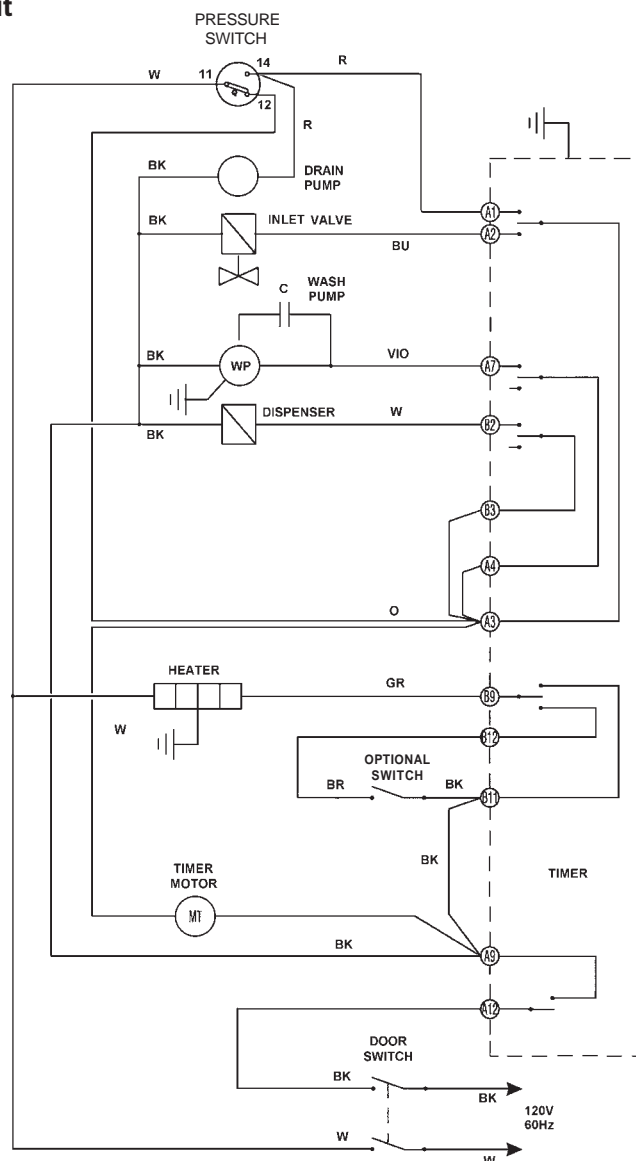



## Troubleshooting the Timer

If the timer is suspected of faulty operation, refer to the Timer Cycle Chart and Timer Strip Circuit and proceed as follows:

1. Index the timer to the first increment of the HEAVY WASH cycle. (This is a drain period which activates the pump motor.)
2. If the pump motor fails to operate during the first cycle increment block, check the electric supply. If there is no electric supply, check the door latch switch. If there is electric supply, disconnect electric supply and check the pump motor component resistance (see **Specifications**, page 4).
3. If the pump motor does operate, let the timer motor advance the timer through the drain increment to determine if the timer motor and drive train are fully operative.
4. Let the timer advance or index it forward to the portion of the cycle in question.
5. If a component controlled by the timer fails to function, as the timer advances through the cycle, check for voltage at the timer terminals. If the voltage is supplied to the component, check the component resistance (see **Specifications**, page 4).

With electric supply disconnected, continuity through timer contacts, other controls, and wires can be checked with an ohmmeter.

If the timer contacts fail to close in the sequence shown on the timer cycle chart, are burned (have resistance measurable with an ohmmeter), or don't advance automatically, replace timer.

## Timer Strip Circuit

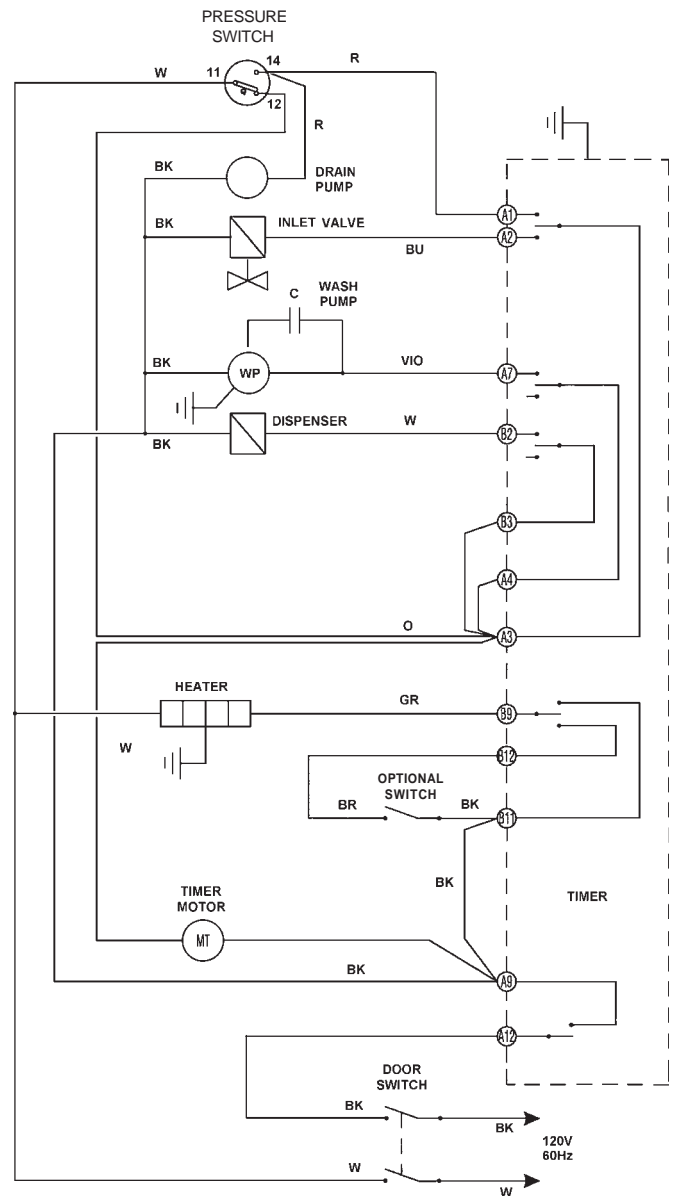

## Timer Cycle Chart

LOC	COLOR	FUNCTION	5	10	15	20	25	30	35	40	45	50	55	60
A4	A7 VIO	WASH PUMP	[Active]											
A3	A2 BU A1 R	INLET VALVE DRAIN PUMP	[Active]											
A9	A12 BK	BUS	[Active]											
B3	B2 W	DISPENSER	[Active]											
B9	B11 BK B12 BR	WASH HEATING DRYING HEATING	[Active]											
PROGRAM START			1	2	3	4	5	6	7					
PROGRAMME START														
SWITCH			RINSE 6MIN.	RINSE 6MIN.	RINSE 6MIN.	RINSE 6MIN.	RINSE 6MIN.	WASH 24MIN.	RINSE 6MIN.	RINSE 14MIN.	DRY HOT OR COOL 36MIN.		RESET	
F	E	CYCLE												
		POTS & PANS	[Active]											
		POST&PAN	[Active]											
		HEAVY WASH	[Active]											
		NORMAL WASH	[Active]											
		LIGHT WASH	[Active]											
		CHINA CRYSTAL	[Active]											
		RINSE & HOLD	[Active]											
		RINSE&HOLD	[Active]											
		DRY	[Active]											
O	X	HEAT DRY	[Active]											
X	O	COOL DRY	[Active]											





- If the water does not touch the heating element, disconnect power, close the door, and check the incoming water pressure. A minimum incoming water pressure of 20 PSI (138 kPa) is needed to properly fill the dishwasher basin.

### Water Fill Valve Will Not Shut Off

- Turn on the dishwasher and allow the bottom of the basin to start filling with water. Disconnect power while the basin is filling. If water continues to flow, turn off the water supply and replace the water fill valve.
- If the water turns off when power is disconnected, troubleshoot the timer and motor. Replace the defective part.

### Water Fill Valve Strip Circuit

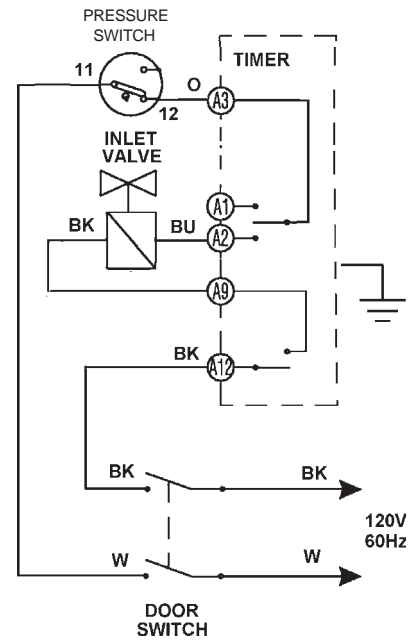

## Troubleshooting Checklist

The troubleshooting checklist is common for all dishwasher models. They use different parts to accomplish the same thing and diagnosis will remain similar.

When a problem arises, and a possible cause is listed, follow the test and remove or replace procedures as outlined in this Technical Service Manual.

The wiring diagram, schematic, and timer cycle chart are a necessity when making electrical checks. In most cases, an ohmmeter will handle all the tests necessary.

To verify the setup of any particular cycle of operation, refer to the Owner's Manual.

<b>SYMPTOM</b>	<b>CHECK FOR THE FOLLOWING</b>	<b>REMEDY</b>
Dishwasher will not operate when turned ON.	1. A blown fuse or tripped circuit breaker.	1. Replace the fuse or reset the breaker.
	2. Damaged or defective wiring.	2. Repair the wiring.
	3. Defective timer contacts.	3. Replace the timer.
	4. Improper motor resistances.	4. Replace the motor.
	5. Defective door switch contacts.	5. Replace the door switch.
	6. Defective door latch.	6. Replace the door latch.
Dishwasher runs but will not heat.	1. Defective heat selector switch.	1. Replace the heat selector switch.
	2. Heater element is open.	2. Replace the heater element.
	3. Defective timer contacts.	3. Replace the timer.
	4. Damaged or defective wiring.	4. Repair the wiring.
Dishwasher runs but will not stop.	1. Timer motor inoperative.	1. Replace the timer.
	2. Damaged or defective wiring.	2. Repair the wiring.
	3. Defective timer.	3. Replace the timer.
Dishwasher runs with door open.	1. Defective door safety switch.	1. Replace the door safety switch.
Motor hums but will not start or run.	1. Defective motor bearings.	1. Replace the motor.
	2. Knob position advanced beyond fill.	2. Advance the knob to the next wash cycle.
	3. Defective motor capacitor.	3. Replace the motor capacitor.
Motor trips out on internal thermal overload protector.	1. Improper motor voltage.	1. Replace the motor.
	2. Motor shaft binding.	2. Replace the motor.
	3. Motor windings shorted.	3. Replace the motor.
Repeated dishwasher cycles.	1. Defective timer.	1. Replace the timer.
Timer does not advance automatically.	1. Timer motor is stalled or open.	1. Replace the timer.
	2. Timer not providing power to timer motor.	2. Replace the timer.
	3. Timer shaft binding or knob interference to escutcheon.	3. Repair or adjust timer shaft or knob.
Etching on glassware.	1. Soft water condition (Natural or artificial).	Have a sample of the water analyzed by the local water department.
Dishwasher continues to fill even though there is no voltage to the fill valve (flooding condition).	1. Defective water fill valve.	1. Replace the water fill valve.
	2. Debris buildup under the diaphragm in the water fill valve.	2. Clean out the debris or replace the water fill valve.

<b>SYMPTOM</b>	<b>CHECK FOR THE FOLLOWING</b>	<b>REMEDY</b>
No heat during the dry cycle.	1. Defective heat switch.	1. Replace the heat switch.
	2. Defective heater element.	2. Replace the heater element.
	3. Defective timer.	3. Replace the timer.
	4. Damaged or defective wiring.	4. Repair the wiring.
Dishwasher will not fill with water or will not fill properly.	1. The water supply is turned off.	1. Turn the water supply on.
	2. Low water pressure.	2. Minimum water pressure of 20 PSI.
	3. Defective water fill valve.	3. Replace the water fill valve.
	4. Obstructed water fill valve or hose.	4. Disassemble and clean the water fill valve and hose.
	5. Defective timer.	5. Replace the timer.
	6. Timer advanced past start of fill cycle.	6. Instruct the customer on the proper setting of the timer.
	7. Damaged or defective wiring.	7. Repair the wiring.
	8. Defective pressure switch.	8. Replace the pressure switch.
	9. Heavy water usage elsewhere in home.	9. Use dishwasher when water usage is at a minimum.
Dishwasher will not pump out.	1. Defective drain pump.	1. Replace the drain pump.
	2. Defective impeller.	2. Replace the impeller.
	3. Defective timer.	3. Replace the timer.
Water siphons out.	1. Drain hose loop too low.	1. Move the drain hose to the proper height.
	2. Drain line connected to a floor drain not properly vented.	2. Install a vent air gap at counter top.
Too much water fill.	1. Defective water fill valve.	1. Replace the water fill valve.
	2. Defective timer.	2. Replace the timer.
	3. Timer advanced past the start of the drain cycle.	3. Instruct the customer on the proper setting of the timer.
Water leaks from dishwasher.	1. Too much water fill.	1. See previous symptom.
	2. Defective tub seal.	2. Replace the tub seal.
	3. Defective vent plate.	3. Replace the vent plate.
	4. Dishwasher door not level.	4. Adjust the dishwasher door.
	5. Dishwasher not level.	5. Level the dishwasher.
	6. Soap suds leak from dishwasher.	6. Refer to use and care manual.
	7. Loose hose clamps.	7. Tighten or replace hose clamps.
	8. Loose heater element.	8. Tighten heater element mounting nuts.
	9. Defective water seals.	9. Replace the water seals.
	10. Motor and pump assembly not seated properly in tub liner bottom.	10. Remount the motor and pump assembly in the tub liner bottom.

<b>SYMPTOM</b>	<b>CHECK FOR THE FOLLOWING</b>	<b>REMEDY</b>
Poor washability.	1. Improper loading of dishes, pots, pans, and nesting of silverware.	1. Instruct the customer on proper loading of the dishwasher. Refer to the owners manual.
	2. Defective spray arm.	2. Check spray arm for proper rotation.
	3. Water level should cover heating element.	3. See "Dishwasher will not fill with water or will not fill properly" symptom.
	4. Defective detergent/rinse module.	4. Replace the detergent/rinse module.
	5. Old, improper amount, or wrong type of detergent used (detergents lose effectiveness in a damp area).	5. Instruct the customer on proper use of dishwasher detergent. Refer to the owners manual.
	6. Low incoming water temperature.	6. Incoming water temperature of 140°F is required to properly dissolve dishwashing detergents.
	7. Clogged filter assembly.	7. Clean the filter assembly and microfilter.
Poor drying of dishes.	1. Improper loading of dishes, pots, pans, and nesting of silverware.	1. Instruct the customer on proper loading of the dishwasher. Refer to the owners manual.
	2. Low incoming water temperature.	2. Incoming water temperature of 140°F is required to properly dissolve dishwashing detergents.
	3. Water remaining in tub after drain cycle is completed.	3. See "Dishwasher will not pump out" symptom.
	4. Defective heating element.	5. Replace the heating element.
	5. Damaged or defective wiring.	2. Repair the wiring.
Door will not latch.	1. Defective door latch.	1. Replace the door latch.
Noisy pump assembly.	1. Defective motor bearings.	1. Replace the pump motor.
	2. A sucking sound is heard at the end of the cycle.	2. This is a normal condition.
Detergent left in the dispenser.	1. Detergent allowed to stand too long in the dispenser.	1. Instruct the customer on proper use of dishwasher detergent. Refer to the owners manual.
	2. Dispenser was wet when detergent was added.	2. Instruct the customer on proper use of dishwasher detergent. Refer to the owners manual.
	3. Detergent is binding on detergent/rinse module cover.	3. Replace the heating element.
	4. Detergent cup held closed or blocked by large dishes.	4. Instruct the customer on proper loading of dishwasher. Refer to the owners manual.

<b>SYMPTOM</b>	<b>CHECK FOR THE FOLLOWING</b>	<b>REMEDY</b>
Noisy pump assembly.	1. Debris in bottom of tub sump area.	1. Clean out the sump area.
	2. Pump parts were not properly installed.	2. Inspect the pump and correct and installation errors.
	3. Impellers are not properly shimmed or are rubbing.	3. Use the shim guage furnished in the impeller seal kit. When the seal is properly shimmed the impellers will be in the correct operating position.
	4. Defective motor bearings.	4. Replace the motor.
	5. A sucking sound is heard at the end of the cycle.	5. This is a normal condition.
	6. Timer advanced past start of fill cycle.	6. Instruct the customer on the proper setting of the timer.
Spotting or filming on glasses (reposition of food soil).	1. Detergent allowed to stand too long in the dispenser or excessive amounts of detergent are being used.	1. Instruct the customer on proper use of dishwasher detergent. Refer to the owner's manual.
	2. Low incoming water temperature.	2. Incoming water temperature of 140°F is required to properly dissolve dishwashing detergents.
	3. Improper loading of dishes, pots, pans, and nesting of silverware.	3. Instruct the customer on proper loading of the dishwasher. Refer to the owner's manual.
	4. Water high in mineral content.	4. Have water analyzed. Use of commercially available rinse agents (such as Jet Dry) helps to reduce the spotting by lowering the surface tension of the water (the water then "sheets" off the dishes).
	5. High incoming water temperature.	5. Incoming water temperature of 160°F or higher will cause high protein food particles to bake onto the dishes before detergent can remove them. Set water heater tank to deliver 140°F water.
	6. Improper installation of the dishwasher to a food waste disposal.	6. Install properly. Refer to installation manual.

# Washability Complaints

**Hot Water** – Ample supply of water at a minimum temperature of 120 °F (48.9 °C) is necessary. Do **not** use dishwasher soon after using clothes washer or filling bathtub.

**Loading** - Consult Owner's Manual on loading procedures.

**Amount of Water** – Make sure dishwasher is level. Check water level, allowing dishwasher to fill normally for first fill. **The water level should be to the heating element.** If water level is low, check for clogged screen and check float switch. See **Water Valve and Float Switch**.

**Detergent/Rinse Module Leakage** – Some moisture in cup is normal. Detergent must not be soaking wet, oozing out, and down the inner door panel. If a leak is detected, check the detergent/rinse module door lid, latch operation, and gasket seal. Also see **Detergent/Rinse Module**.

**Proper Amount of Detergent** – Use full detergent cup of fresh detergent in hard water. Use only enough detergent to get good wash performance in soft water.

**Rinse Agent** – Use rinse agent if spotting or drying is a problem. A rinse agent will improve the water sheeting action and drying performance.

**Water Valve** – See **Water Fill Valve**.

**Spray Arm** – Check to be sure the spray arms spin freely and jets are not clogged. Check to be sure the middle spray arm water conduit is connected properly to the main conduit.

**Drying** – Water inlet temperature must be at least 120 °F (48.9 °C) for proper drying. Low water inlet temperature will prevent proper convection air movement and increase drying time substantially.

A rinse agent will improve the water sheeting action and drying performance.

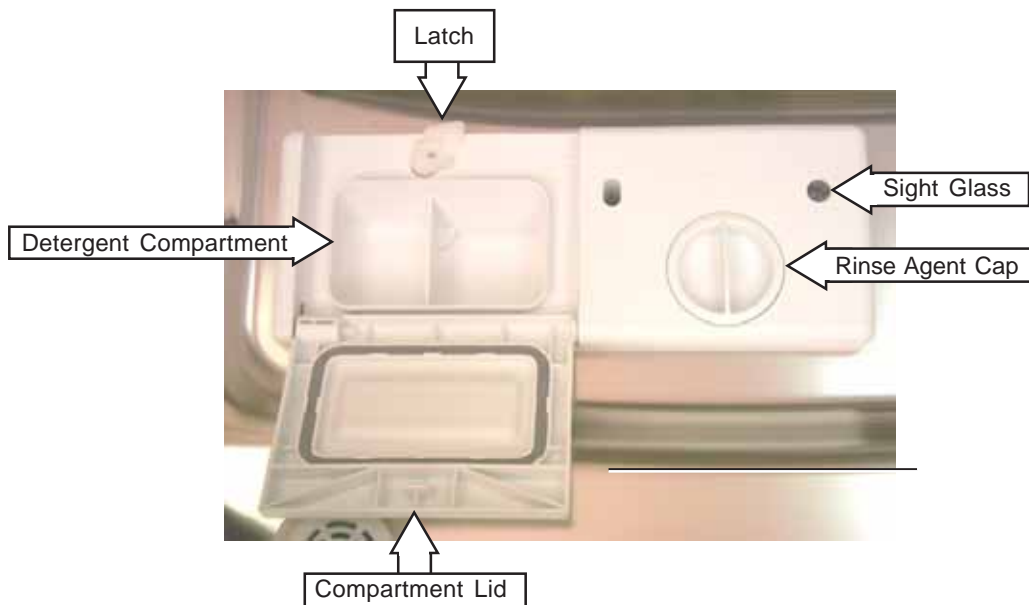

# Schematic

**WARNING:** Power **must** be disconnected before servicing the appliance.

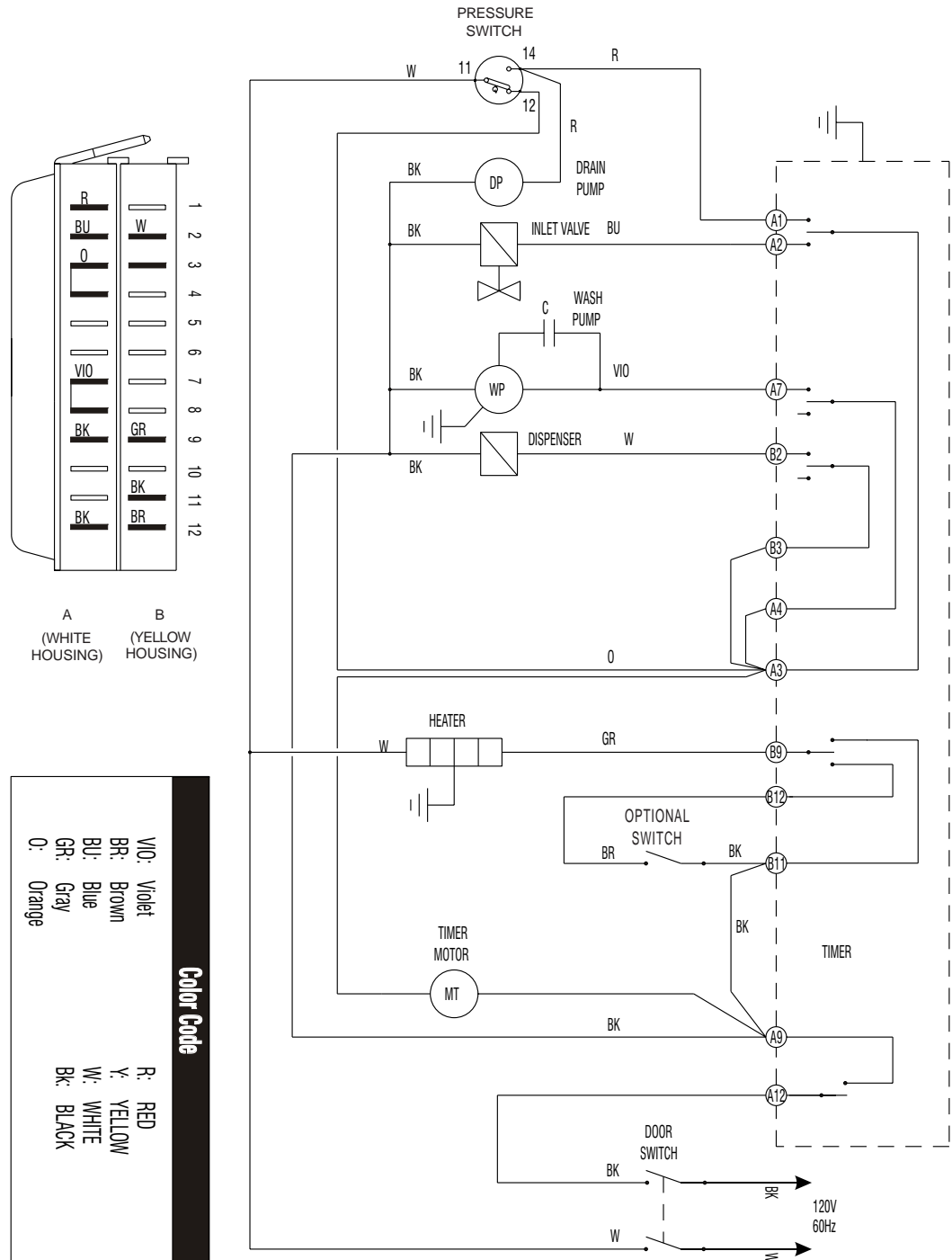

**Note:** Schematic diagram subject to change. Please refer to diagram supplied with product located inside product console.

# Illustrated Parts Catalog

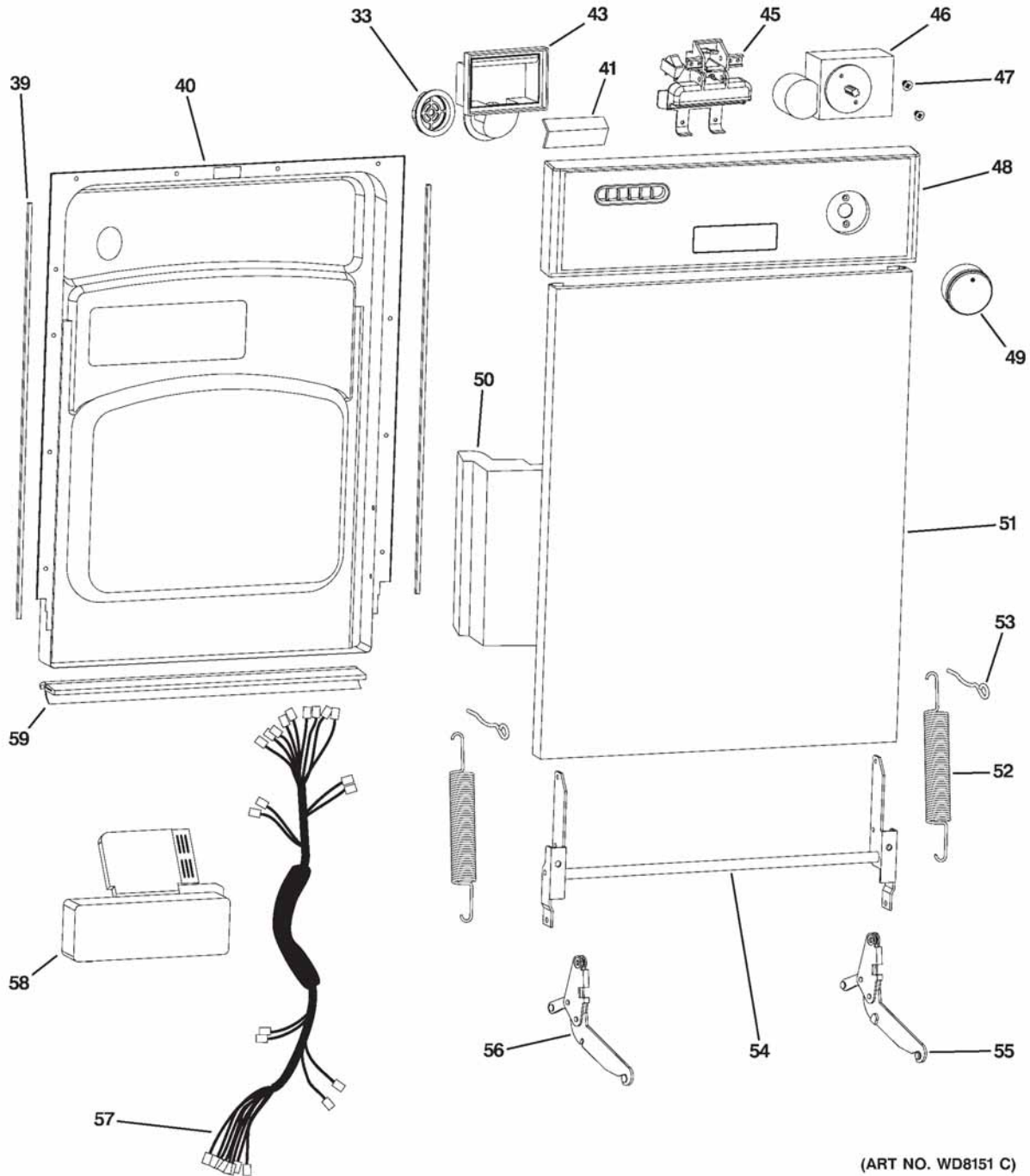

(ART NO. WD8151 C)



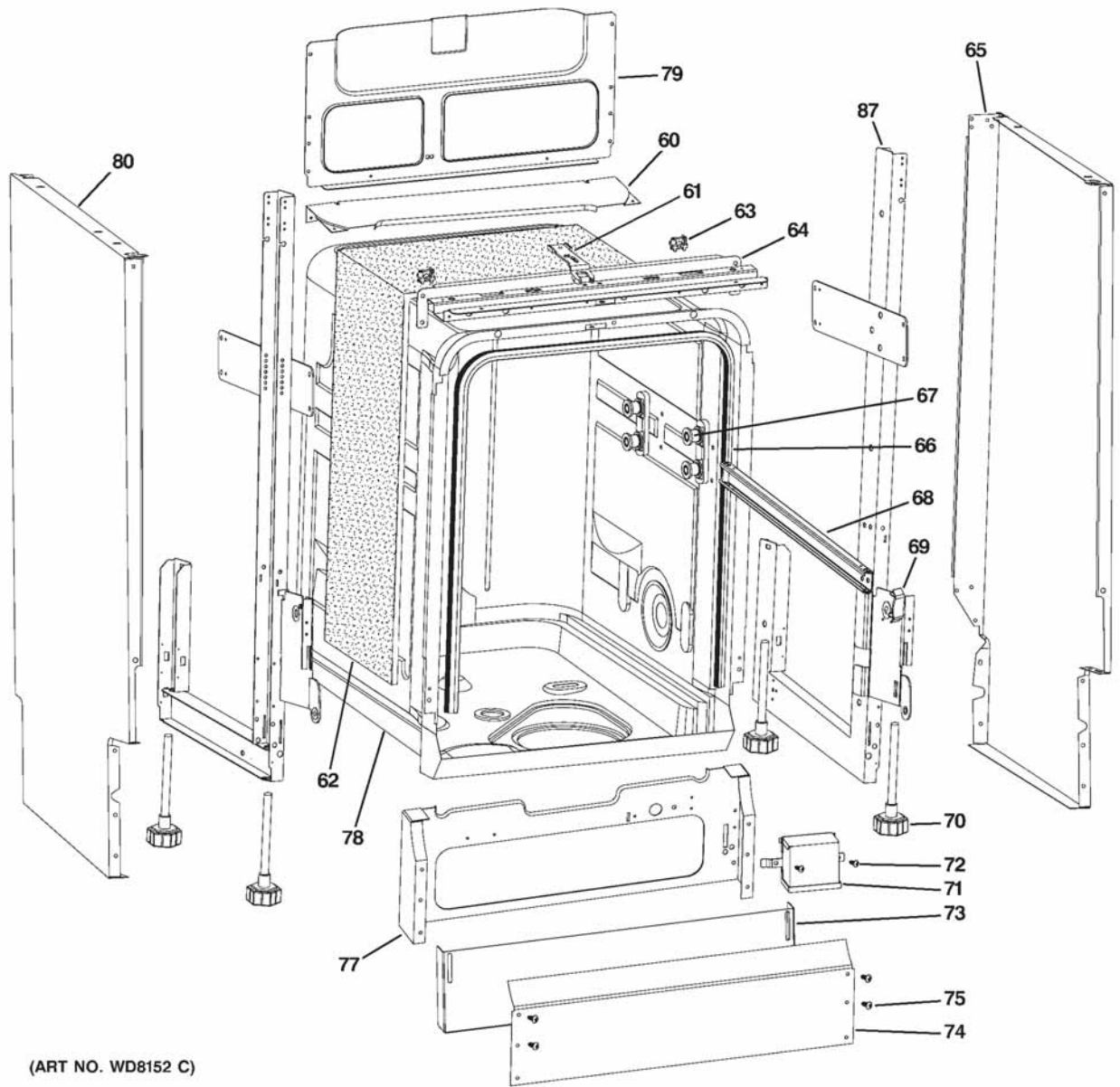

(ART NO. WD8152 C)

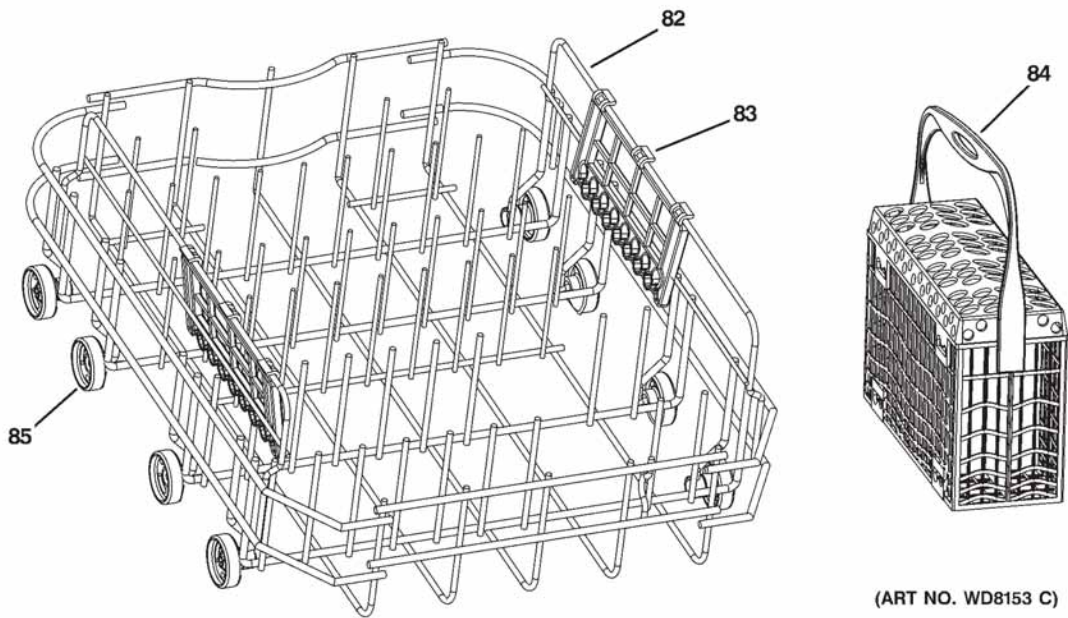
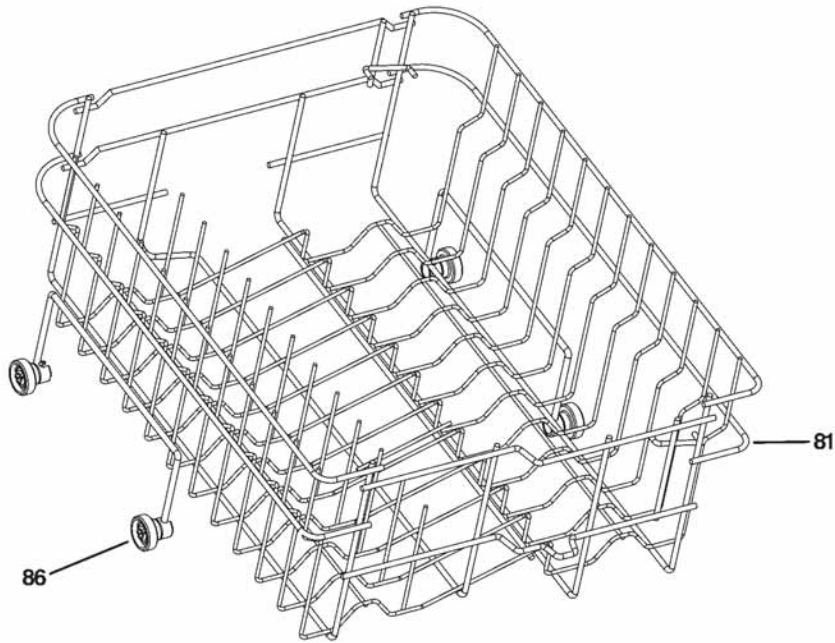

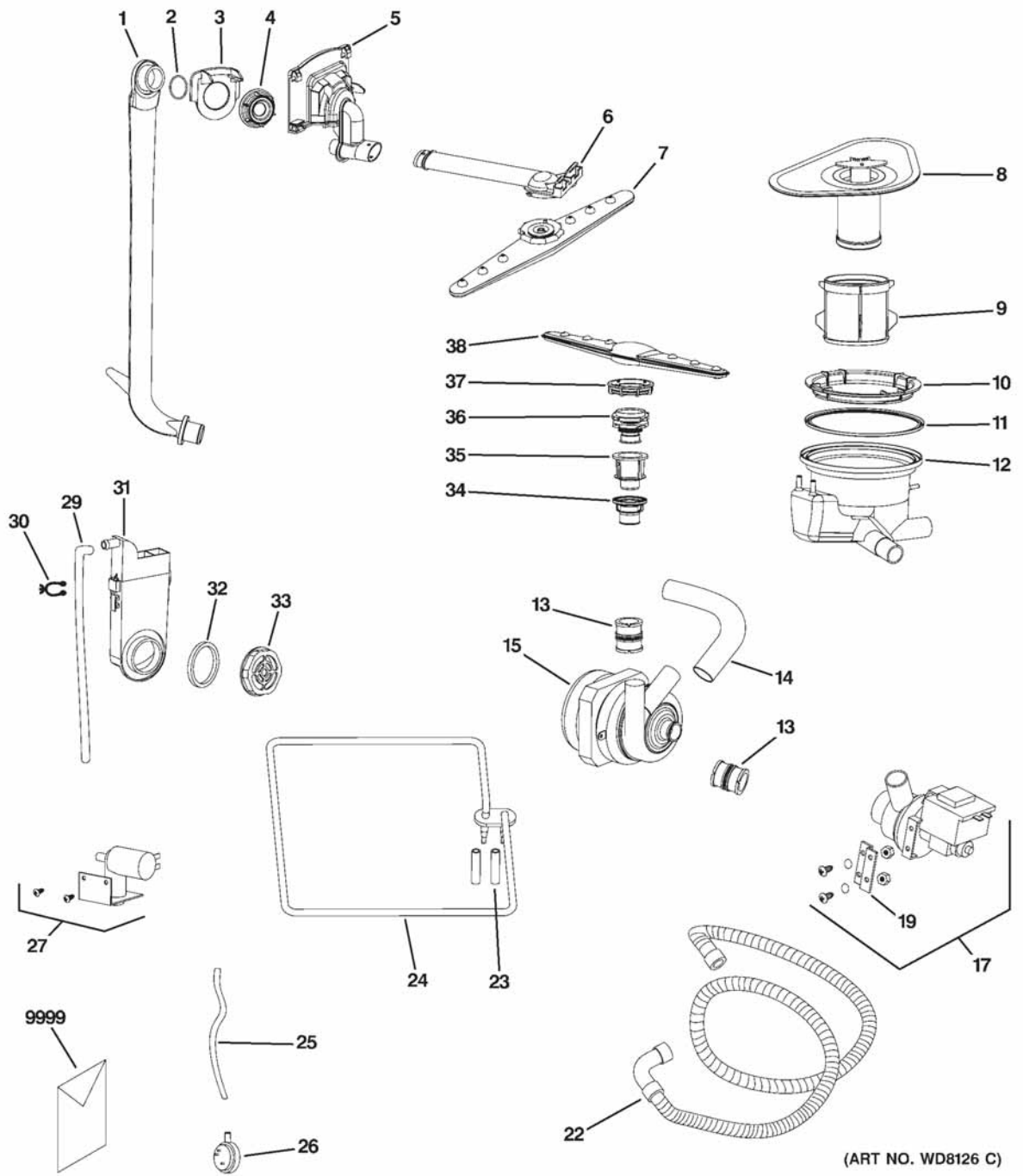

ITEM NO.	DESCRIPTION	CATALOG NUMBER	QTY.
1	MAIN CONDUIT	WD12X10164	1
2	O-RING	WD01X10240	1
3	GUIDE CASING	WD01X10241	1
4	RING NUT W/ GASKET	WD01X10242	1
5	MAIN CONDUIT - UPPER SPRAY	WD12X10165	1
6	CONDUIT - UPPER SPRAY	WD12X10166	1
7	UPPER SPRAY ASM & GASKET	WD22X10039	1
8	FILTER ASM	WD12X10167	1
9	MICROFILTER	WD12X10168	1
10	SUMP CLAMPING NUT	WD12X10169	1
11	SUMP GASKET	WD08X10046	1
12	SUMP	WD18X10027	1
13	CONNECTING DUCT	WD18X10028	2
14	PUMP HOSE	WD24X10028	1
15	MOTOR PUMP ASM	WD26X10020	1
17	DRAIN PUMP ASM	WD26X10021	1
19	MOUNTING PLATE	WD01X10252	1
22	DRAIN HOSE	WD24X10029	1
23	INSULATING SLEEVE	WD01X10253	2
24	HEATING ELEMENT ASM	WD05X10007	1
25	PRESSURE SWITCH HOSE	WD24X10030	1
26	PRESSURE SWITCH	WD21X10191	1
27	WATER VALVE W/ SCREWS	WD15X10009	1
29	FILL HOSE	WD24X10031	1
30	SQUEEZE CLAMP	WD01X10251	1
31	FILL FUNNEL	WD12X10170	1
32	O-RING	WD01X10243	2
33	RING NUT / VENT CAP	WD18X10029	2
34	RING NUT - MANIFOLD SUPP	WD01X10244	1
35	LOWER MANIFOLD SUPPORT	WD18X10030	1
36	LOWER SPRAY SHIFT	WD18X10031	1
37	CONNECTING RING NUT	WD01X10245	1
38	LOWER SPRAY ARM	WD12X10171	1
39	EDGE GUARD WH	WD08X10047	2
40	INNER DOOR	WD31X10074	1
41	VENT BACK BOARD	WD24X10034	1
43	VENT CONNECTING	WD12X10172	1
45	HANDLE / LATCH ASM WH	WD13X10028	1
46	TIMER	WD21X10193	1
47	SCREW	WD02X10119	2
48	CONTROL PANEL	WD34X11025	1
49	KNOB ASM	WD09X10055	1
50	DOOR FOAM	WD01X10246	1
51	OUT DOOR SS	WD31X10079	1
52	DOOR HINGE SPRING	WD03X10024	2

<b>ITEM NO.</b>	<b>DESCRIPTION</b>	<b>CATALOG NUMBER</b>	<b>QTY.</b>
53	DOOR HINGE PIN	WD01X10250	2
54	HINGE ASM	WD14X10018	1
55	RIGHT HINGE ASM	WD14X10020	1
56	LEFT HINGE ASM	WD14X10019	1
57	WIRING HARNESS	WD01X10267	1
58	DETERGENT DISPENSER	WD12X10174	1
59	DOOR GASKET ASM	WD08X10050	1
60	UPPER REAR CROSSPIECE	WD27X10190	1
61	DOOR STRIKE	WD13X10029	1
62	TUB INSULATION	WD01X10249	1
63	HOOK	WD17X10005	2
64	UPPER FRONT BRACE BK	WD27X10192	1
65	RIGHT SIDE PANEL	WD27X10188	1
66	TUB GASKET	WD08X10048	1
67	GUIDE RAIL BRACKET ASM	WD12X10175	4
68	GUIDE RAIL	WD30X10022	2
69	GUIDE RAIL CAP	WD12X10176	4
70	LEVELING LEG	WD02X10118	4
71	JUNCTION BOX & COVER	WD12X10177	1
72	SCREW	WD02X10120	2
73	TOE KICK WH	WD27X10183	1
74	ACCESS PANEL WH	WD27X10184	1
75	SCREW - WH	WD02X10122	4
77	LOWER FRONT BRACE	WD27X10194	1
78	TUB BAND ASM	WD08X10056	1
79	LOWER REAR BRACE	WD27X10191	1
80	LEFT SIDE PANEL	WD27X10189	1
81	UPPER RACK ASM	WD28X10150	1
82	LOWER RACK ASM	WD28X10157	1
83	WINE SHELF	WD28X10158	4
84	SILVERWARE BASKET	WD28X10152	1
85	LOWER STUD & ROLLER ASM	WD12X10178	8
86	UPPER STUD & ROLLER ASM	WD12X10179	4
87	RIGHT UPRIGHTS ASM	WD27X10193	2
9999	MINI MANUAL	31-30448	1
9999	PM INSTALL INSTRUCTIONS	31-30511	1
9999	OWNERS MANUAL	49-5967	1

# Warranty

## GE Dishwasher Warranty.



All warranty service provided by our Factory Service Centers, or an authorized Customer Care® technician. To schedule service, on-line, 24 hours a day, visit us at [GEAppliances.com](http://GEAppliances.com), or call 800.GE.CARES (800.432.2737).

Staple your receipt here.  
Proof of the original purchase date is needed to obtain service under the warranty.

### For The Period Of:      GE Will Replace:

#### One Year

From the date of the original purchase

**Any part** of the dishwasher which fails due to a defect in materials or workmanship. During this **full one-year warranty**, GE will also provide, **free of charge**, all labor and in-home service to replace the defective part.

### What GE Will Not Cover:

- Service trips to your home to teach you how to use the product.
- Improper installation.
- Failure of the product if it is abused, misused, or used for other than the intended purpose or used commercially.
- Replacement of house fuses or resetting of circuit breakers.
- Damage to the product caused by accident, fire, floods or acts of God.
- Incidental or consequential damage caused by possible defects with this appliance.
- Cleaning or servicing of the air gap device in the drain line.

*This warranty is extended to the original purchaser and any succeeding owner for products purchased for home use within the USA. Proof of original purchase date is needed to obtain service under the warranty. In Alaska, the warranty excludes the cost of shipping or service calls to your home.*

*Some states do not allow the exclusion or limitation of incidental or consequential damages. This warranty gives you specific legal rights, and you may also have other rights which vary from state to state. To know what your legal rights are, consult your local or state consumer affairs office or your state's Attorney General.*

**Warrantor: General Electric Company. Louisville, KY 40225**