

Service Manual

**Crosley
Dishwashers**

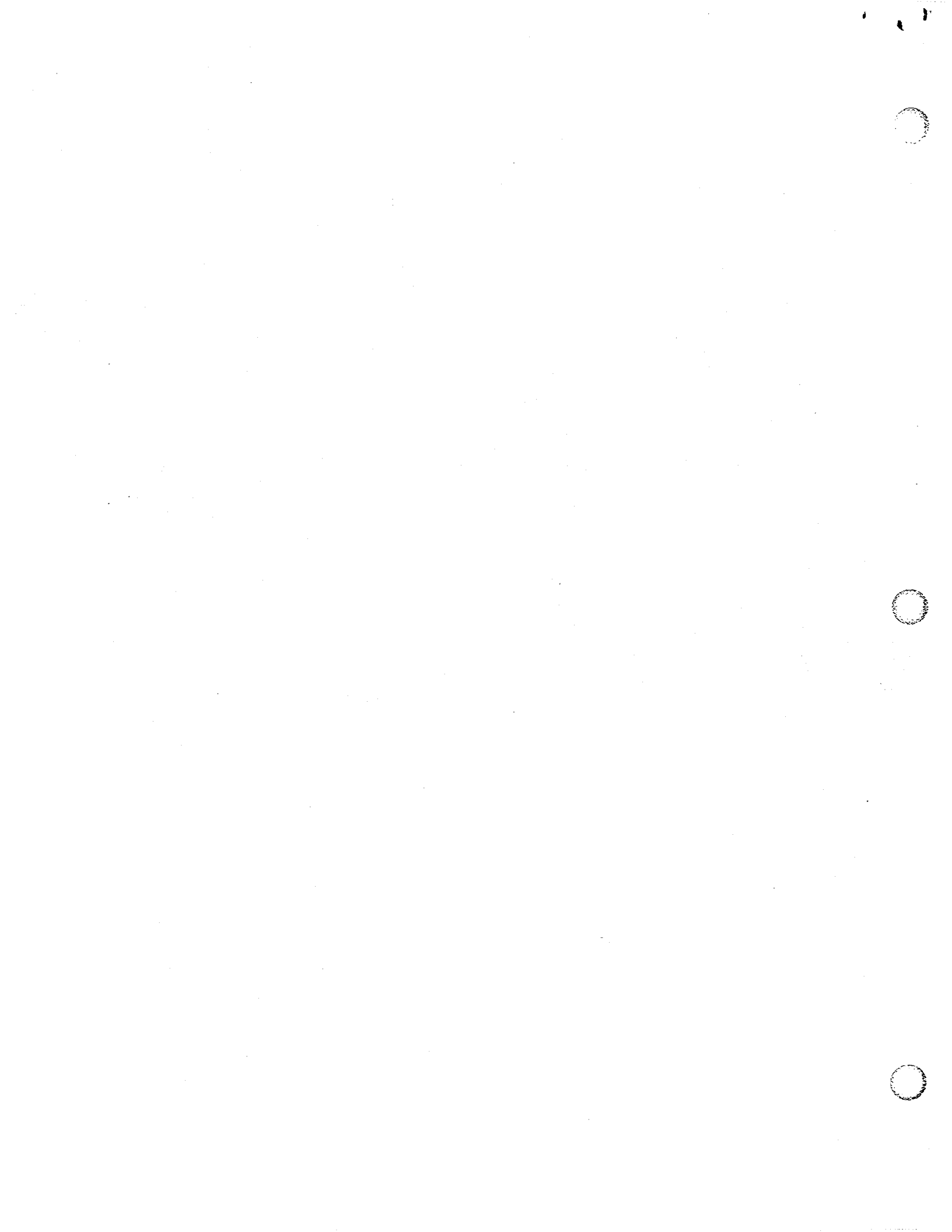

INTRODUCTION

Crosley dishwasher models covered in this manual:

Built-in Models

CDU20J CDU8J CDU5J CDU2J
CDU250 CDU400 CDU450 CDU600

Portable Models

CDC5J CDC400

For additional information on issues encompassed in this manual, including safety issues, contact:

MAYTAG CUSTOMER SERVICE

240 Edwards Street, SE

Cleveland, TN 37311

Phone: 423-472-3333

Fax: 423 -478-0649

The first and most important step of any service call is to accurately determine what the complaint is. This is best accomplished by questioning the customer, finding out what the product is or isn't doing and why they feel a problem exists.

SECTION 1 - covers **Electrical Test Equipment** for use on the dishwasher. This section also covers general use of the equipment, in addition to providing specific information on amperage, wattage, and resistance readings which should be seen.

SECTION 2 - covers **Electrical-Mechanical Troubleshooting** and provides a list of possible complaints. Find the complaint which you feel best matches that provided by the customer and turn to the appropriate page(s). You will find a list of possible electrical and mechanical problems for the complaint, which have been listed in order of:

1. Ease in checking.
2. Probability.

Systematically eliminating these possibilities will allow you to find and correct the problem.

SECTION 3 - covers **Service Procedures**. This section will provide information on location of components, disassembly and/or reassembly procedures, the purpose and/or function of the part, and in some instances, specific checks to be made.

SECTION 4 - covers **General Information** such as brief specifications, cycle descriptions, features, options and schematics.

CONTENTS

GENERAL SAFETY PRECAUTIONS	(Inside Front Cover Page)
INTRODUCTION	i-ii
CONTENTS	iii-iv
SECTION 1. ELECTRICAL EQUIPMENT AND TESTING	1-1
ELECTRICAL TEST EQUIPMENT	1-1
Appliance Test Meter	1-1
Clamp-On Ammeter	1-3
Motor Test Cord	1-3
ELECTRICAL TESTS	1-4
Water Valve Test	1-4
Cycle Extender	1-4
Wax Motors Check - Detergent and Rinse Aid Dispensers	1-6
Drive Motor Test	1-7
Drain Solenoid Test Cord Hook Up	1-8
Voltage Checks	1-8
Grounding and Polarity	1-9
SECTION 2. ELECTRICAL-MECHANICAL TROUBLESHOOTING	2-1
GENERAL INFORMATION	2-2
COMPONENTS	2-1
ELECTRICAL-MECHANICAL CHECKS: ALL MODELS	2-1
TROUBLESHOOTING: MICROPROCESSOR MODELS	2-7
SECTION 3. SERVICE PROCEDURES	3-1
OUTER DOOR PANEL	3-1
ACCESS AND TOE PANELS	3-1
INNER DOOR PANEL	3-2
DISPENSER ASSEMBLY AND WAX MOTOR(S)	3-3
DOOR LATCH SWITCH HOLDER ASSEMBLY	3-5
CONTROL PANEL BARRIER	3-6
CONTROL SWITCH	3-6
CYCLE EXTENDER	3-6
TIMER	3-6
MICROPROCESSOR BOARD (On Select Models)	3-8
CONTROL PANEL FACIA	3-8
DOOR GASKET	3-9
DOOR HINGES	3-9
DOOR LATCH STRIKE	3-10
HINGE SPRINGS	3-11
UPPER WASH ARM	3-12
UPPER WASH ARM HOSE	3-12

FLOAT ASSEMBLY	3-13
VENT COVER	3-13
SUDS RESERVOIR/CONVECTION VENT INLET	3-14
START RELAY	3-14
HEATING ELEMENT	3-15
THERMOSTATS	3-16
WATER VALVE	3-7
WATER INJECTOR	3-19
PUMP ASSEMBLY	3-21
Chopper Plate Assembly	3-22
Volute	3-23
Water Seal Sea	3-24
Drain Solenoid and Lifter Assembly	3-24
Motor	3-25
UPPER RACK REMOVAL	3-26
PORTABLE DISHWASHERS	3-27
Wood Top	3-27
Cabinet	3-27
Casters	3-29
Faucet Coupler	3-29
Retainer For Faucet Coupler	3-30
SECTION 4. GENERAL INFORMATION	4-1
SPECIFICATIONS (SECTION A) CDU20J, CDU8J, CDU5J, CDU2J, CDC5J	4-1
WARRANTY	4-2
CONTROL PANELS	4-3
CYCLES AND OPTIONS	4-4
ELECTRICAL DIAGRAMS AND SCHEMATICS	4-6
SPECIFICATIONS (SECTION B) CDU250, CDU400, CDU450, CDU600, CDC400	4-15
CONTROL PANELS	4-16
CYCLES AND OPTIONS	4-17
ELECTRICAL DIAGRAMS AND SCHEMATICS	4-20

GENERAL SAFETY PRECAUTIONS

Information contained in this manual is intended for use by a qualified technician familiar with proper and safe procedures to be followed when repairing an electrical appliance. All tests and repairs should be performed by a qualified service technician equipped with proper tools and measuring devices. All component replacements should be made by a qualified service technician using only factory approved replacement parts.

Improper assembly or adjustment may occur if service or repair is attempted by persons other than qualified service technicians or if parts other than approved replacement parts are used. Improper assembly or adjustment can create hazardous conditions.

There can be risks of injury or electrical shock while performing services or repairs. Injury or electrical shock can be serious or even fatal. Consequently, extreme caution should be taken when performing voltage checks on individual components of a product. Except as necessary to perform a particular step in servicing a product, the electrical power supply should **ALWAYS** be disconnected when servicing a product.

Further, this appliance **must** be properly grounded. Never plug the appliance into a receptacle that is not properly grounded and in accordance with all local and national codes. See installation instructions for grounding this appliance.

IMPORTANT SAFETY NOTICE AND WARNING

The California Safe Drinking Water and Toxic Enforcement Act of 1986 (Proposition 65) Requires the Governor of California to publish a list of substances known to the State of California to cause cancer or reproductive harm, and requires business to warn customers of potential exposures to such substances.

SECTION 1. ELECTRICAL EQUIPMENT & TESTING

ELECTRICAL TEST EQUIPMENT

The equipment required to service these products depends largely upon the condition encountered. Locating a malfunction will often require the use of electrical testing equipment such as:

- Appliance Test Meter
- Clamp-On Ammeter
- Motor Test Cord

Appliance Test Meter

CAUTION

Always disconnect power supply before making continuity checks or taking resistance readings.

An Appliance Test Meter is a multi-purpose tester combining an AD-DC voltage tester with a multi-range ohmmeter.



TEST METER

Probably the easiest means of testing electrical components is “continuity testing” with an appliance test meter. Continuity is a complete or continuous path from one point in an electrical circuit to another.

The obvious advantages of being able to check electrical components and circuits without power applied is one of the features of the ohmmeter. Multiple ranges allow accurate determination of resistances of both single components and entire circuit paths. Resistance is measured in “ohms”.

SET METER FOR USE AS FOLLOWS:

1. Calibrate meter by touching test probes together and turning adjusting dial until meter reads “0” on the ohm scale. Recheck calibration whenever adjusting dial for ohms settings is changed. (Replace battery if adjustment will not bring meter reading to “0”.)
2. Select the scale most easily read and place test probes on respective terminals. When checking a switch, the reading would normally be either open or closed. A reading of 70 on the R x 10 scale would for example be 700 ohms resistance.

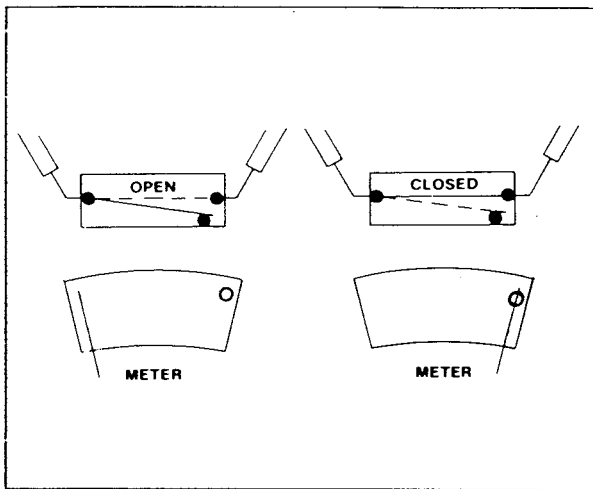

CAUTION

Always be sure the power has been disconnected before making resistance measurements. Failure to do so will result in damage to your meter! Internal batteries provide all the power needed to make resistance checks. They should be checked at least once a year and replaced as needed.

For the most part, we will only be concerned with continuity. Is there a path or not? References made between a “closed” (continuity) reading and an “open” (no continuity) reading. One note, when you get an “open” reading, try a higher resistance range (setting). A very high resistance appears as an “open” on the lower ranges. For best accuracy always “re-zero” meter when changing ranges and/or the physical position of the meter.

Electrical components fall into two general categories:

1. **LOADS-** Devices that **use** or consume electricity. Examples

would include drive motor, heating elements, lamps, timer and solenoid coils.

Continuity tests of “load” devices will show varying levels of resistance from very low for some transformer and motor windings to very high for some timer motors and components on electronic control boards. Usually it is more important to know if there is a path for current flow through a device (continuity) than to know the exact resistance (ohms) of the device.

2. **SWITCHES-** Devices that **control** the supply of electricity to the load or loads in a circuit. Examples include door switches, timer contacts, selector switch and relay contacts.

Continuity test of switches will show virtually no resistance across closed contacts. Resistance, even low values, indicate burned or dirty contacts in a switch.

Continuity testing is a process of eliminating electrical components involved in a given function of the appliance, until the inoperative part is found. By reviewing the list of possible electrical problems under a given condition, and then performing appropriate continuity checks of the parts involved, you should be able to locate the electrical component which is inoperative.

Note: When checking components or circuit paths for continuity, external wiring should be disconnected to eliminate false readings through external paths. Isolate what you want to test.

Clamp-On Ammeter

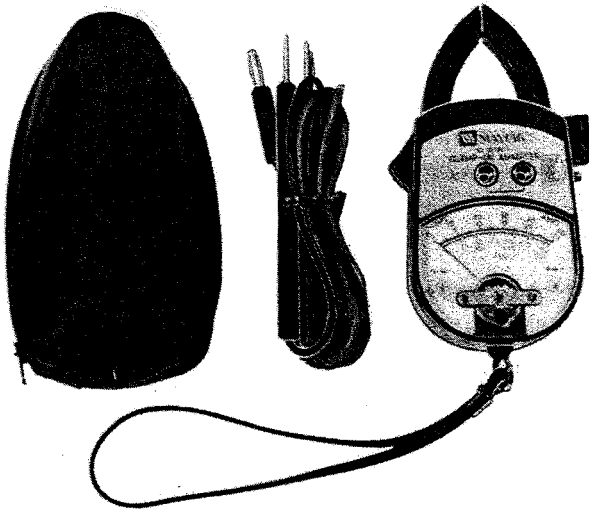

Each circuit in an appliance has a "normal" current draw which is an indication of the performance of that circuit. Current draw levels, less than or more than normal, give clues to malfunctions. The clamp-on ammeter measures these currents without breaking the circuit by measuring the strength of the magnetic field developed around each conductor. Current is read by separating the conductors and clamping the jaws of the ammeter around each conductor on which current is to be read. Low amperage readings indicate problems such as damaged heating elements, etcetra. High amperage readings indicate the unit being tested is operating under an increased mechanical or electrical load.

Note: Overloads on a circuit breaker or fuse can be traced to the product being tested or the circuit breaker (or fuse) by checking the product's current draw. If the amperate reading is less

than the breaker reading, the breaker or fuse box is at fault.

USE OF AMMETER ON DISHWASHER

1. **Motor Current-** The reading can be taken at the leads on the motor start relay or at the molex connector.
2. **Heating Element Current-** The reading can be taken using either lead to the element.

AMPERAGE CHART

CYCLE	AMPS
Wash	2.6
Drain (Start)	6.5
Circulate Heat	11.0
Heat Only	5 - 5.4

Motor Test Cord

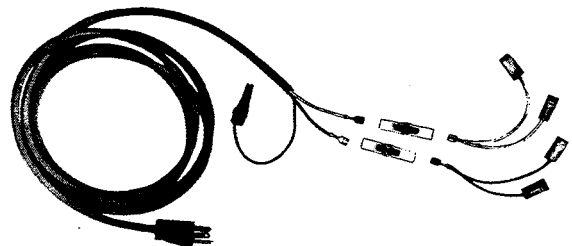

NOTE

Always plug test cord into a grounded receptacle.

A motor test cord may be used to electrically check operation of the various electrical components without removing them from the unit. Testing in this manner merely determines whether or not the part will function independently of other electrical components. In order to make accurate tests, proper connection of the motor test cord is important. With the aid of the drawings under Drive Motor Test, installation of the motor test cord may be done quickly and accurately.

ELECTRICAL TESTS

Water Valve Test

The water valve may be checked without removing it from the dishwasher.

To check the water valve for operation hook up the test cord as follows:

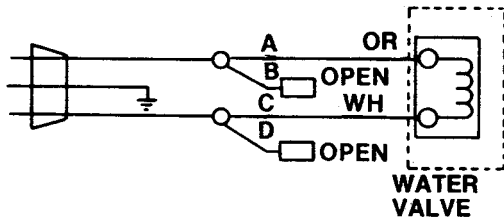

Cycle Extender

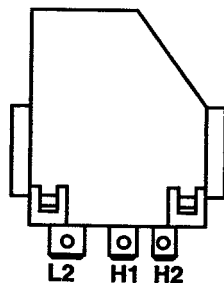

The extender switch is used to open and close the voltage circuit to the timer motor. This interruption of the timer motor will cause the dishwasher to continue running and lengthen the cycle.

The extender is used on mechanical timer dishwashers to extend the Wash and Dry cycles.

Approximately 10 minutes are added to the Wash cycle when Normal is selected; another 10 minutes are added if Super Scrub is selected. This will result in raising the water temperature about 1° per minute during the extended wash. If Water Heat is selected, the Water Temp Thermostat is used in the Wash Cycle.

Approximately 10 minutes are added to the Dry cycle when Normal or Super Scrub are selected with Heat Dry.

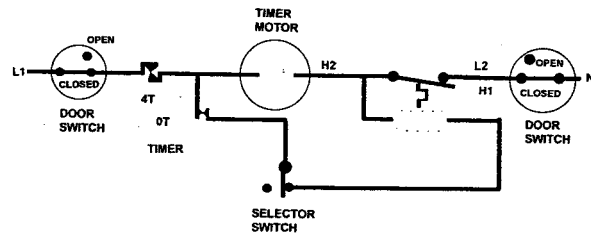

SWITCH OPERATION: Note the electrical schematic. The bi-metal switch is normally a closed switch.

- When 120 VAC is applied to the internal resistor (5400 ohms) across terminals H1 and H2, the resistor will heat up.
- In 15 seconds, the heat will cause the internal bi-metal switch to warp and open the switch across terminals H2 and L2. Terminals H2 and L2 provide the neutral circuit to the timer motor and the internal resistor, thus momentarily stopping the timer motor and shutting down the extender's internal heater.
- After approximately 45 seconds, the bi-metal will have cooled and the switch will close again across terminals H2 and L2. Neutral circuit is restored to the timer motor and the extender's internal heater.
- This sequence is then repeated over and over again till the timer motor advances the timer through the designated cam increments.

RESISTANCE CHECKS

H1 to H2	5400 ohms	Approx.
L2 to H2	0 ohms	Power Off
L2 to H2	OPEN	Power ON - 15 sec.

CAUTION

Always disconnect power supply before making any electrical checks.

COMPONENT	APPROX. OHMS
Cycle Extender	5400
Heating Element	22
Timer Motor	2700-3000
Solenoid - Pull (Pump)	34
Solenoid - Water Valve	900
Wax Motors - (Dispenser Assembly)	2900

These values are provided so that you may have an idea of the resistance that you can see in testing. These resistances are not meant to be used as the exact values to determine whether a component should be replaced.

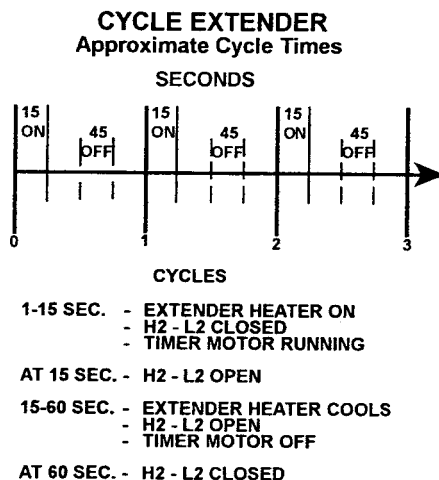

Wax Motors Check - Detergent and Rinse Aid Dispensers

Original series through series "B5" designated product incorporated a Dual Wax Motor Dispenser. This comprised of two wax motors individually designated for activation of the detergent cup cover and the releasing of rinse aid from the reservoir.

Series "B6" and later models incorporated a Single Wax Motor Dispenser. Comprised of a single wax motor to activate both the releasing of the detergent cup cover and rinse aid from the reservoir.

To check the operation of the wax motor, removal from the dispenser retainer or inner door is not necessary.

First snap the detergent cup door shut. Then connect a power test cord across the two terminals of the wax motor. Plug the power test cord into a 120 VAC receptacle. The plunger in center of wax motor should "push out" and actuate the dispenser in approximately 45 - 60 seconds. On Single Wax Motor Dispensers, remove voltage to the wax motor and allow the plunger to retract into the wax motor. Apply voltage to the plunger again and observe for proper lifting of the rinse aid plunger.

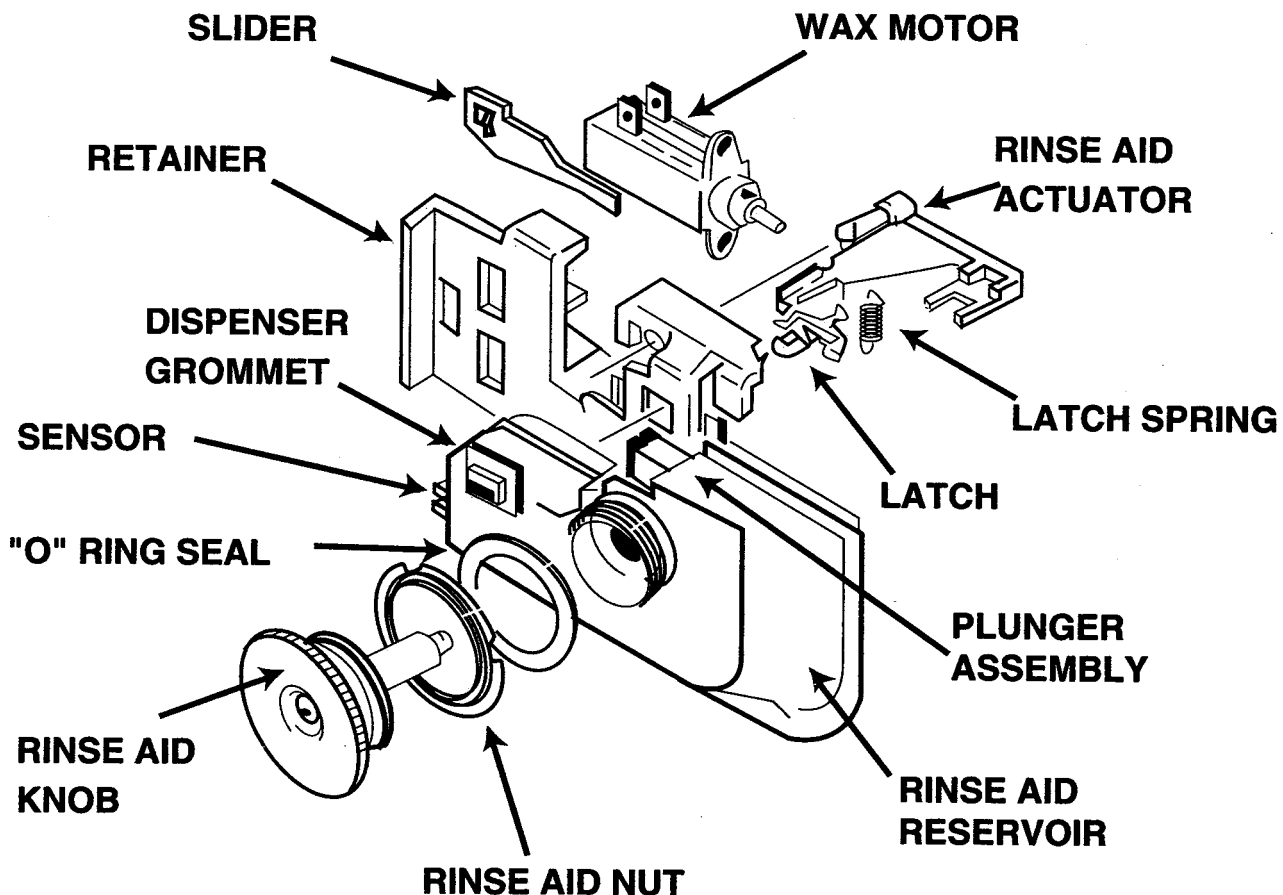

Drive Motor Test

An external start relay and a connector is used to couple the wire harness to the motor wires.

The start relay is mounted on the ceiling of the tub support and consists of a coil and a switch. The coil is in series with the main winding in the motor. When the motor is first energized, the current draw in this series circuit is enough to close the switch in the start relay. This closed switch provides a path for neutral for the start winding and the motor starts. Once the motor is up to speed, the current draw decreases and the coil can no longer hold the switch closed. When the switch opens, the start winding drops out of the circuit.

Note: The relay has to be in an upright position to work properly.

To test the motor we need to separate the connector. This can be done by pushing out the latches on each end and pulling at the same time. The following drawings will help in making the proper connections for testing.

Plug test cord into properly polarized and grounded receptacle.

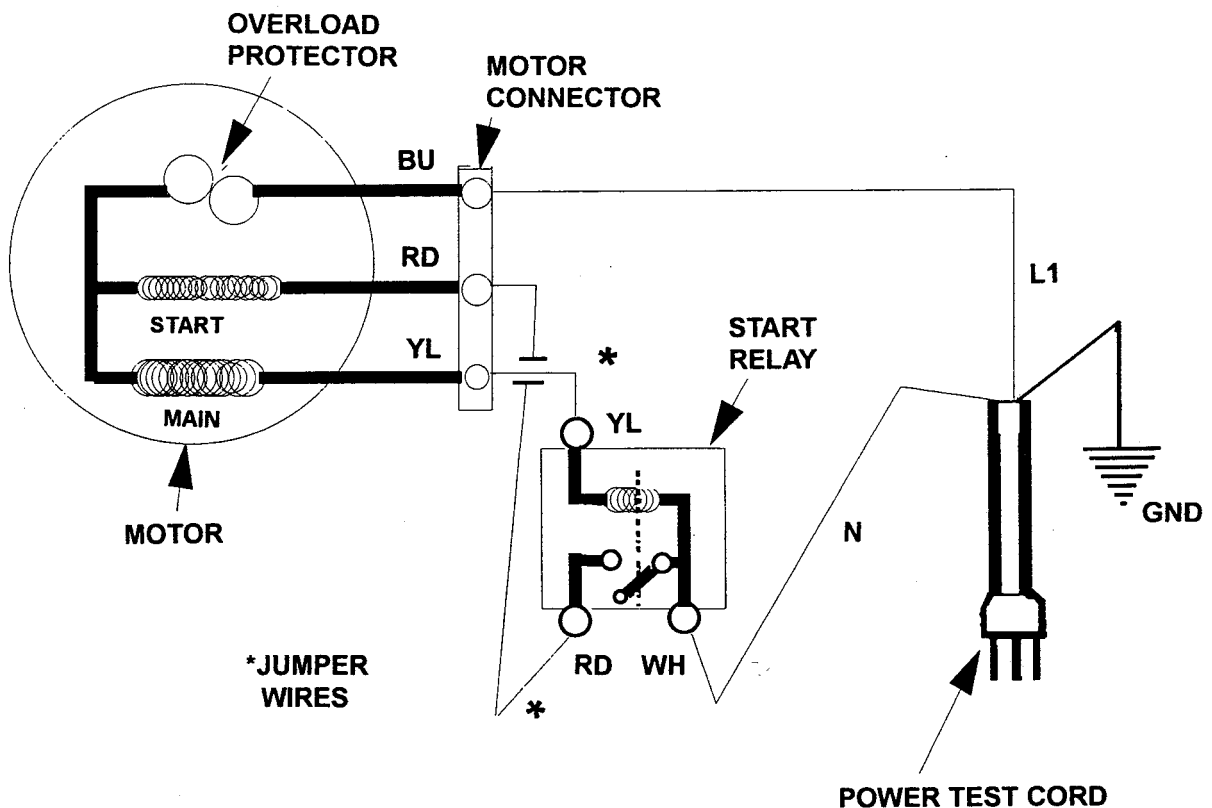

Note: DAMAGE TO THE MOTOR WILL RESULT IF THE START RELAY IS BYPASSED AND THE TEST CORD IS CONNECTED DIRECTLY TO THE MOTOR CONNECTOR.

Drain Solenoid Test Cord Hook Up

To test, connect power cord as shown, plug power cord into 120 VAC receptacle. If solenoid does not operate, replace solenoid. If solenoid operates, check internal pump components.

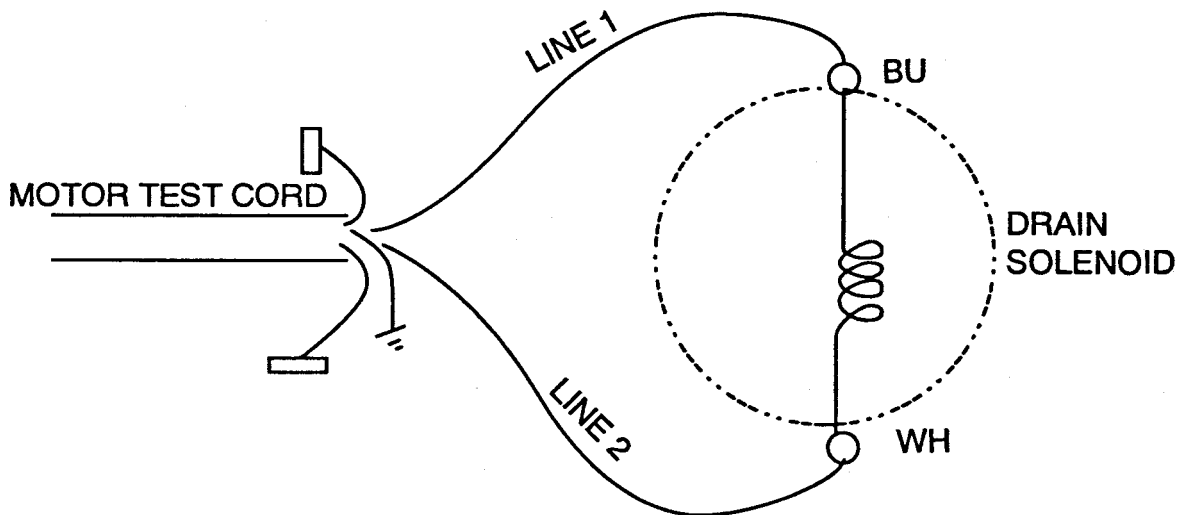

Extreme caution should be taken when performing voltage checks due to danger of possible electrical shock. Except as necessary to perform a particular step in servicing a product, the electrical power supply should ALWAYS be disconnected when servicing a product.

Voltage Checks

For the most part these checks will consist of taking readings at the wall receptacle in order to determine the availability of voltage to the product. Voltage checks on individual components of a product are not recommended due to the possibility of electrical shock. Component part testing is best accomplished through continuity checks with an **Appliance Test Meter**. (See page 1-1.)

Note: Use of the meter on voltage higher than the indicated range may cause permanent damage to the meter. To prevent damage, first select highest range and then lower the range for readings which fall within the lower scale.

SET UP METER FOR USE AS FOLLOWS:

1. Turn selector knob to desired meter function and appropriate range.
2. Plug black lead into socket marked - (black).

3. Plug red lead into socket marked + (red).
4. Place test leads into receptacle in order to determine voltage available.

should be plugged directly into a properly grounded and polarized receptacle.

Do not cut or remove the grounding prong from this plug.

WATTAGES

CYCLE	WATTAGE
Circulate (Wash)	500-560
Drain	700 dropping to 200
Dry	620-680
Super Scrub (Wash)	1100-1250

It is the responsibility of the person installing the appliance to assure it is adequately grounded and polarized at the point of installation taking into consideration local conditions and requirements. In cases where only a two (2) prong receptacle is available, it is the personal responsibility of the customer to have it replaced with a properly ground and polarized 3 prong receptacle. All grounding and wiring should be done in accordance with national and local codes. **USE OF ADAPTERS IS NOT RECOMMENDED.**

Grounding and Polarity

The receptacle used for all Crosley products operating on 120 VAC must be properly grounded and polarized.

The power cord used on the appliances should be equipped with a three (3) prong polarized grounding plug for protection against shock hazard and

CAUTION

Use extreme care when checking voltage.

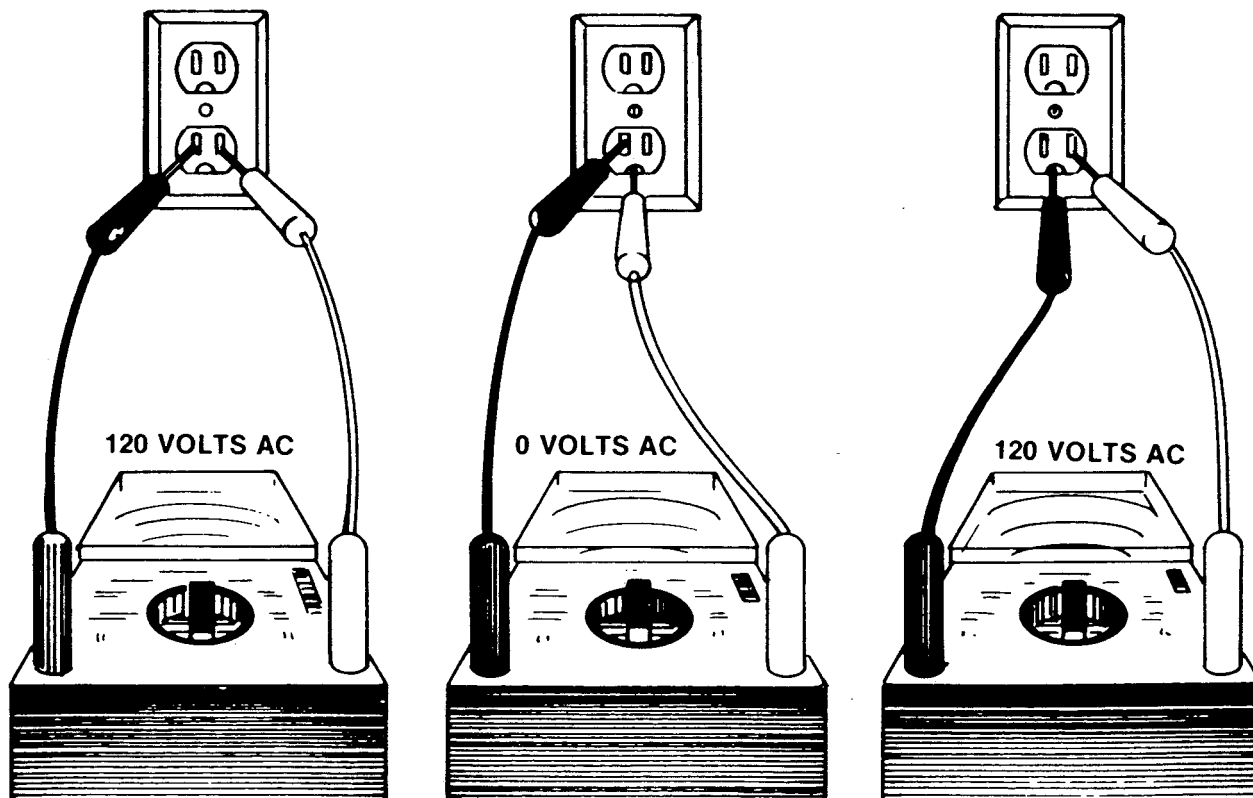

SECTION 2. ELECTRICAL-MECHANICAL TROUBLESHOOTING

GENERAL INFORMATION

The malfunction of an electrical circuit cannot easily be diagnosed unless you first understand how it functions when operating normally.

COMPONENTS

There are two basic categories for electrical components, **switches** and **loads**.

A **switch** controls the current path to a load component. Door switches, tem-

perature controls and push-to-start are examples of switching components. An electrical **load** uses electricity to perform some function. Motors convert electricity to magnetic fields and then to mechanical motion. Lamps convert electricity to light.

The schematic wiring diagram is followed much like a road map. The lines represent the wiring connections between components. When possible, switches are shown in their normal position electrically without actuation.

ELECTRICAL - MECHANICAL CHECKS: ALL MODELS

The following are electrical and mechanical checks for all dishwashers, except for the unique microprocessor controlled systems. For electrical checks on microprocessor models *see respective section titled TROUBLESHOOTING - MICRO-PROCESSOR MODELS*.

CAUTION

ALWAYS disconnect power supply before making any electrical checks.

WILL NOT FILL

Water Access Valve Check to determine if valve is turned on and water is available to the dishwasher. Check water pressure. Normal pressure is 18-120 p.s.i.

Circuit Breaker/Fuse Check if tripped or blown, reset or replace.

Float Check whether stuck in the "UP" position or disengaged from the arm of the switch below.

Water Valve Check solenoid for continuity. No continuity, replace water valve. Check inlet screen for restrictions. Clean screen by flushing. Replace valve if necessary.

Door Latch Check latch adjustment and door switches for continuity. With door switches engaged, check for continuity. No continuity, replace door switch.

Float Switch Check for continuity. No continuity with float in "DOWN" position, replace float switch.

Selector Switch Check per electrical schematic. Replace if necessary.

CAUTION

Except as necessary to perform a particular step in servicing a product, the electrical power supply should **ALWAYS** be disconnected when servicing a product.

Timer Check for continuity per electrical schematic. Replace if necessary.

OVERFLOWS

Float Check whether stuck in "DOWN" position. Check for sediment buildup. Clean and/or replace float.

Float Switch Check continuity of float switch with float in "UP" position. If continuity is present and float is not sticking, replace float switch.

Float Switch Actuator Lever Check and determine if actuator on bracket is sticking. Clean and/or replace if necessary.

Water Valve Check whether water continues to flow when electrical power is turned off. If water continues to flow without electrical power, replace water valve. **NOTE:** *Low water pressure can also result in failure of the valve to close properly.*

SLOW FILL

Water Valve Inlet Screen Check screen for sediment buildup. Flush screen and/or replace valve.

Water Supply Line Check to determine if hose is kinked or pinched. Straighten hose or remove obstruction in dishwasher enclosure area.

Low Water Pressure Check water pressure. Normal pressure should be 18-120 p.s.i.

SIPHONING

Drain Hose Check proper elevation of drain hose. Must have drain hose loop of 32 inches high. Reposition hose to correct

elevation. Check if air gap was installed with food waste disposal unit or if drain pipe is too small.

Drain Flapper Check for "Auto-Drain." Examine position of the flapper in the volute. Be sure the flapper is in "DOWN" position and not positioned "UP." Adjust arm of flapper "UP" to insure engagement of flapper over the drain opening. Or install "Auto-Drain" kit, part number 904031.

POOR CIRCULATION

Water Level - Too Low Water level should be 1/2 - 3/4 inch below the heating element.

Drive Motor Check motor, (*see page 1-7*). If motor does not run when timer is between "START" and "DRY," replace motor.

Pump Assembly Check assembly for obstruction or restricted parts. Repair assembly.

Timer Check for continuity between the timer terminals per electrical schematic. No continuity, replace timer.

Wiring And Electrical Connections Check for loose or frayed wires and terminal connections. Replace and/or repair all electrical connections.

Seal Ring Check seal rings between lower spray arm support and pump assembly. If out of position or damaged, reposition or replace.

POOR WASHABILITY

Spray Arms Check upper and lower arms for blockage of water ports. Check proper rack loading to avoid spray arm

CAUTION

Except as necessary to perform a particular step in servicing a product, the electrical power supply should **ALWAYS** be disconnected when servicing a product.

interference during wash action and to make sure the center spray tower is not blocked.

Filter Screen (Select Models) - Check for blocked or clogged pump filter or strainer (e.g. jar labels).

Detergent Cup Cover Check spring hinge operation of detergent cup cover.

Drain Flapper Check for "AUTO-DRAIN." Examine position of the flapper in the volute. Be sure the flapper is down and not positioned up. Adjust the arm of the flapper up to ensure engagement of flapper over the drain opening. If necessary, install "AUTO DRAIN" kit, part number **904031**.

Dispenser Wax Motor(s) Check linkage of dispenser assembly and positioning of spring. Use motor test cord to check the wax motor. (Full extension reached in 45 - 60 seconds.) Ohms check should be approximately 1900 ohms. Check wire harness to wax motor. Perform continuity checks of harness leading from timer to wax motor.

Rinse Dispenser Check level of rinse aid in reservoir. Check plunger for proper alignment and mating to the top of the reservoir. Check the rinse dispenser cap for residue buildup on end of stem. Clean or replace required parts if necessary.

Timer Check for closure of dispenser contact per schematic.

WILL NOT DRAIN

Wiring And Electrical Connections

Check for loose or frayed wires and termi-

nal connections. Replace and/or repair all electrical connections.

Drain Hose Kinked or restricted. Reroute the drain hose and remove any restrictions

Drain Solenoid Check for continuity of the solenoid. No continuity, replace solenoid.

Flapper Check engagement of flapper metal arm with lifter of solenoid assembly. Readjust or replace necessary parts. Check for sticking of flapper across drain outlet of pump housing.

Drive Motor Check motor and start relay, (*see page 1-7*). If motor runs when energized, but stops when drain is initiated, check for voltage drop. If voltage is below 105 VAC, have house wiring checked.

Flapper Check engagement of flapper metal arm with lifter of solenoid assembly. Readjust or replace necessary parts. Check for sticking of flapper across drain outlet of pump housing.

Drive Motor Check motor and start relay, (*see page 1-7*). If motor runs when energized, but stops when drain is initiated, check for voltage drop. If voltage is below 105 VAC, have house wiring checked.

Pump Assembly Check assembly for obstructions or restricted parts. Repair assembly.

Selector Switches Check continuity between switch terminals per electrical schematic. No continuity, replace switch.
Timer Check the timer for activation of drain solenoid for 1-7 seconds at beginning of drain cycle, (if longer, replace timer).

CAUTION

Except as necessary to perform a particular step in servicing a product, the electrical power supply should **ALWAYS** be disconnected when servicing a product.

Check for continuity across the timer terminals per electrical schematic. No continuity, replace timer.

Inadequate Drainage Check the drain pipe which connects to the drain hose and have repairs done as recommended. If draining to disposer, check for unprocessed food waste. Run disposer if necessary.

CONTINUES TO DRAIN

Siphoning Check proper elevation of drain hose. Must have drain hose loop of 32 inches high. Reposition hose to correct elevation. Check if air gap was installed with food waste disposal unit or if drain pipe is too small.

Timer Check for timer advancement. Timer motor running and timer not advancing, replace timer. Timer motor not running, replace timer motor. Check closure of drain contact per schematic.

Drain Flapper Check for "AUTO DRAIN." Examine position of flapper in the volute. Be sure the flapper is down and not positioned up. Adjust arm of flapper over the drain opening. Install "AUTO DRAIN" kit, part number 904031, if necessary.

POOR DRYING

Wiring And Electrical Connections Check for loose or frayed wires and terminal connections. Replace and/or repair all electrical connections.

Water Temperature Check for low water temperature. Temperature should be between 120° and 140° F. If not, advise customer to adjust water heater and to purge water lines to the dishwasher area prior to starting dishwasher.

Detergent Cup Cover Check spring hinge operation of detergent cup cover. Check for proper amount of detergent usage. Check for water hardness. Use one teaspoon of detergent per one grain of water hardness.

Rinse Dispenser Check level of rinse aid in reservoir. Check plunger for proper alignment and mating to the top of the reservoir. Check the rinse dispenser cap for residue build up on end of stem. Clean or replace required parts if necessary.

Dispenser Wax Motor(s) Check linkage of dispenser assembly and positioning of spring. Use motor test cord to check wax motor, (full extension reached in 45-60 seconds). Ohms check should be approximately 1900 ohms. Check wire harness to wax motor. Perform continuity checks of harness leading from timer to wax motor.

Heating Element Check for continuity of element. Check terminal to terminal for continuity. No continuity, replace element. Check terminal to element sheath, continuity found, replace element.

Thermostat Check proper placement of thermostats. Check mating surface of thermostat face to surface of tub enclosure, must be flat. Adjust thermostat if necessary. Check continuity of thermostats. Water Heat thermostat is normally OPEN and the Hi-Limit thermostat is normal CLOSED at room temperature.

Low Ambient Temperature Check for under counter drafts due to house insulation voids, cold air returns and air conditioning ducts. If necessary, add insulation along back of dishwasher. Maintain clearance of wiring, hose and blower assembly.

CAUTION

Except as necessary to perform a particular step in servicing a product, the electrical power supply should **ALWAYS** be disconnected when servicing a product.

Improper Rack Loading Check how customer loads dishes into rack. Improper loading can deflect water from reaching the detergent cup area and hinder air circulation inside of dishwasher.

Selector Switches Check continuity between switch terminals per electrical schematic. No continuity, replace switch. (Heater and blower circuit.)

Timer Check for terminal continuity of timer terminals for activation of heating element and detergent/rinse aid dispenser per schematic. Check timer wire harness connector for damaged or loose terminals.

Convection Vent Inlet/Suds Reservoir Check reservoir for blockage due to suds build-up or water. Remove and drain the reservoir if necessary. Check for cracked lower spray arm or use of high sudsing detergent.

WATER LEAKS

Installation Check unit for proper leveling and squareness of door opening.

Door Alignment Check proper alignment of door liner to door gasket. Use chalk rubbed onto rib of liner, close then open door. Observe chalk markings on door gasket. Adjust door hinges or leveling legs to align door into center of gasket. Screws should be tightened to 75 in. lbs.

Door Gasket Check door latch adjustment. If correct, check for torn or

damaged gasket. Replace gasket if torn or damaged.

Hoses Check for loose hose clamps or hoses that leak. Tighten clamps and replace leaking hoses.

Spray Arm - Upper & Lower Check for cracks and replace if necessary.

Lid Latch Grommet Detergent cup cover area. Check for positioning or cracking. Replace if necessary.

Rinse Dispenser Seal Check positioning of rinse dispenser seal to inner door liner. Reposition or replace if necessary.

Pump Gasket Check for leak between pump assembly and tub. If gasket is leaking, adjust locking ring to increase tension of pump assembly to tub. Replace gasket if necessary.

Pump Housing Check for holes or cracks in housing. Replace if necessary.

Water Seal Assembly Check seal and seat assembly in lower pump assembly. Check tightness of motor fan to impeller assembly. Replace pump impeller assembly with seal if necessary.

Water Valve Check valve body for damage and leaks. Replace if necessary. Also check plumbing connections.

Heating Element Check secureness of mounting nuts and integrity of O-ring seal between tub and heating element terminal.

NOISE PROBLEMS

Before servicing unit, check to be sure noise is not normal operating sound. (See User's Guide.)

Banging Check loose spray arms or nozzle. Check fastener holding upper spray arm to support. Check load for interference with wash arm.

Buzzing Check and tighten timer mounting screws. Check timer motor for noise, if severe replace timer or timer motor. Check drain solenoid and water valve mounting screws.

Chattering Check water valve for noise. Replace if necessary.

Grinding Check for obstructions in pump assembly. Check for tight fit of motor fan to pump impeller assembly. Re-tighten if necessary.

Hammering Check and tighten water valve bracket mounting screws. Check water valve and drain solenoids for proper operation. Check for low voltage or high resistance in the drain solenoid circuit. Note: Some noise is normal. Is an air chamber or anti-

hammer device installed on the water line behind the appliance or on the main water supply? If necessary replace the drain solenoid or water valve.

Ticking Check for loose fan on pump motor assembly.

Rattle Check for loose wear ring in chopper plate assembly. Check for obstructions in chopper blade area.

Snap Detergent cup cover noise is normal when door is first opened after a cycle.

Thumping Check for object in path of spray arms. Remove objects in path. Check for obstructions in pump assembly and remove. Check for damage to pump assembly and repair if necessary.

Vibration Check for loose screws and tighten. Insert panels may need adjusting and additional pads can be added.

Popping & Clicking Normal timer noise.

TROUBLESHOOTING: MICROPROCESSOR MODELS

Following are Electrical checks unique to Microprocessor dishwashers. For Mechanical checks refer to Electrical-Mechanical section for all dishwashers.

A microprocessor board performs the same functions as a mechanical timer. However, a microprocessor board can check all circuits in the dishwasher and provide a digital display.

In a mechanical timer unit, the timer controls the individual components by opening and closing cam switches in the timer.

In a microprocessor unit, this is accomplished by using control relays on the board. The control relays are specifically assigned to individual components: motor, heater, water valve,

detergent and rinse dispenser wax motors.

NOTE: All individual components on the dishwasher outside of the microprocessor board and the Water Temp Thermostat operate on 120 VAC. The Water Temp Thermostat circuit operates on 24 - 30 VAC.

The microprocessor board receives the necessary voltage to operate through a transformer on the board.

The user selects a dishwasher cycle and options by pressing the indicated pads on the fascia of the control panel.

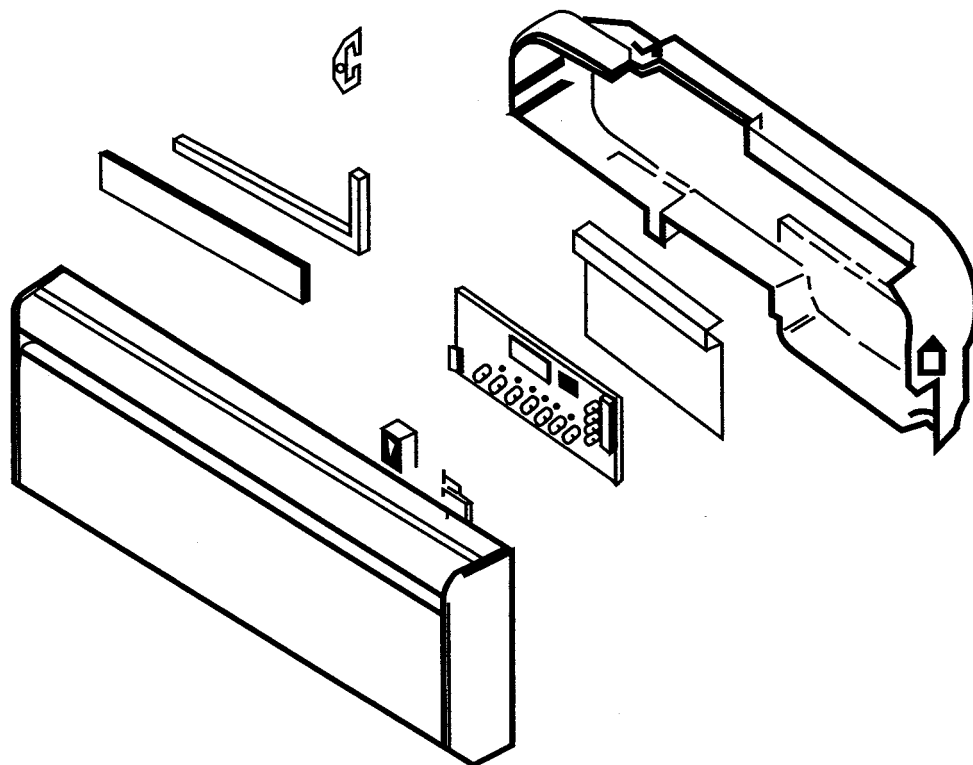

Refer to section titled "TROUBLESHOOTING: ALL MODELS" to identify specific problem. **IMPORTANT:** When referencing to this section, check for proper voltage of 120 VAC at the individual component being specifically checked.

WILL NOT PROGRAM

Door Touch pads will not program with the door unlatched.

Circuit Breaker/Fuse Check if tripped or blown, reset or replace. Must have 120 VAC present to the microprocessor board. (Check electrical schematic.)

Wire Harness Connections Determine if wiring harness is properly attached to terminals of microprocessor board.

Microprocessor Board With 120 VAC available to the board and board not functioning, replace board.

Board - Voltage Check (Input and Output Voltages)

Input Voltage: When running a specific function and the component part will not work, check for voltage leading to the board. (WHT & BLK wires at the board.)

Output Voltage: Review the electrical schematic for the wire designation of the component part you wish to check. Perform a voltage check from the designated board terminal you identified and the White wire (Neutral). If no voltage is present, replace the microprocessor board.

TEST CYCLES

All of the following test modes are started by pressing the following initial sequence of circled keys followed by a specific key that starts the selected test:

Super Scrub
Normal Wash
Energy Saver
Water Heat
Drying Heat
Start
Cancel

(Next key determines selected test mode.)

	1	2	3			6
CYCLES	SUPER SCRUB	NORMAL WASH	ENERGY SAVER	CHINA CRYSTAL		START
EXTRA RINSE	WATER HEAT	DRYING HEAT	RINSE & HOLD	OPTIONS		CANCEL
	4	5				7

Note: To end any of the following Test Modes, press the **CANCEL** key.

CIRCUIT BOARD TEST

This is a Quick Test Program which will turn on the relays and LED lights for 1/2 second, one at a time. This will repeat indefinitely until the **Cancel** key is pressed.

To start press the initial sequence of keys, then press **Drying Heat**.

CYCLES	SUPER SCRUB	NORMAL WASH	ENERGY SAVER	CHINA CRYSTAL		START
EXTRA RINSE	WATER HEAT	DRYING HEAT	RINSE & HOLD	OPTIONS		CANCEL
	8					

(See section titled ELECTRICAL SCHEMATICS for specific model functions.)

DISHWASHER FUNCTION TEST (Available on select models only.)

This is a longer test mode. After the first 50 seconds the display will count down from 12 minutes and then begin sequencing through the cycles. The test sequence will not repeat.

To start press the initial sequence of keys, then press **Super Scrub**.

	8					
CYCLES	SUPER SCRUB	NORMAL WASH	ENERGY SAVER	CHINA CRYSTAL		START
EXTRA RINSE	WATER HEAT	DRYING HEAT	RINSE & HOLD	OPTIONS		CANCEL

(See section titled ELECTRICAL SCHEMATICS for specific model functions and LED displays.)

RAPID TIME DOWN TEST

This test may be performed without pressing the initial sequence of keys. To start test, select a cycle function and press the key. Within one minute, press the same key again and hold down the Delay key. The control will advance through the selected cycle at a rate of "One Minute Per Second". This will do so as long as the Delay key is continuously depressed. For some cycles, you'll have to release the cycle key while holding down the Delay key.

SECTION 3. SERVICE PROCEDURES

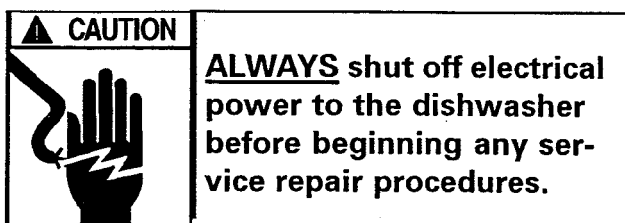

EXTREME CAUTION! Should be taken when performing voltage checks due to danger or possible electrical shock. Except as necessary to perform a particular step in servicing a product, the electrical power supply should **ALWAYS** be disconnected when servicing a product.

CAUTION! There can be risk of injury or electrical shock while performing services or repairs. Injury or electrical shock can be serious or even fatal.

OUTER DOOR PANEL

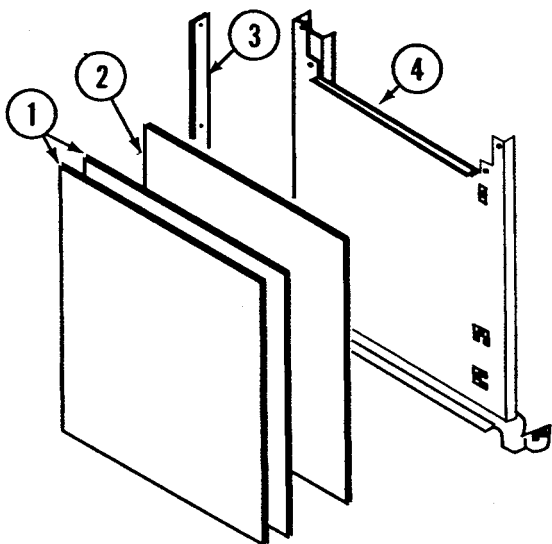

<u>No.</u>	<u>Description</u>
1	Front Insert
2	Front Filler
3	Door Trim
4	Door Panel

To Change Panels

1. Disconnect the power supply to the dishwasher.
2. Remove three screws holding the trim strip on one side of the door. Take note of how the trim comes off.
3. Grasping the lower part of the door panels, bow panels out carefully at the bottom while sliding panels far enough to clear the flange on the trim strip, which was not removed, and remove panels.
4. Arrange panels so the desired color is facing out.
5. Place door panels (notched side up) behind the metal trim at the bottom of the door. Bow the panels so they fit behind the control panel at the top.
6. Slide the panels under the side metal trim. It may be necessary to compress the backing behind the colored panels.
7. Reinstall the trim that was removed earlier. Align the holes and replace the three screws.

ACCESS AND TOE PANELS

Removal of access and toe panel will allow access to water valve, blower assembly, start relay, door spring, adjustment screws, float switch assembly, hoses, electrical junction box and pump assembly.

To Remove

1. Disconnect the power supply to the dishwasher.
2. The lower access panel is held by four screws (two above the panel and two below). Remove all four screws.
3. Toe panel can now be removed by sliding out from between tub support legs.

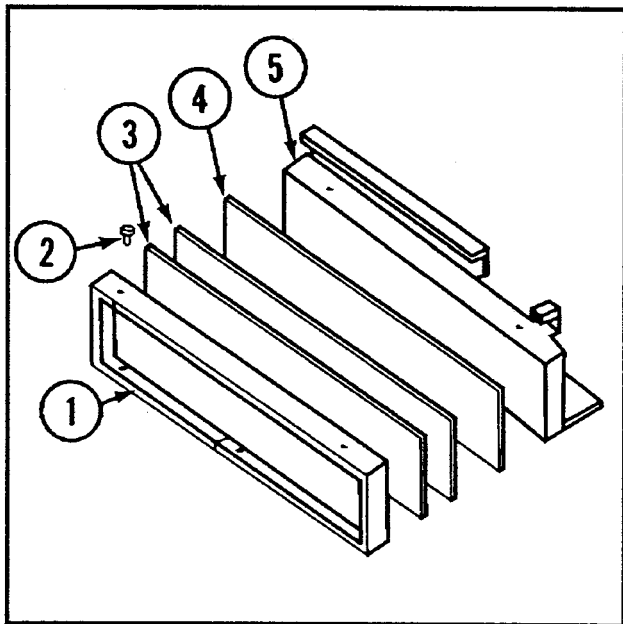

<u>NO.</u>	<u>DESCRIPTION</u>
1	Access Trim
2	Trim Screw (Cross Recess)
3	Access Insert
4	Access Filler
5	Access Panel

To Change Panels

With the lower access panel removed, remove the four screws along the bottom of the panel and the two on the top. Remove the trim which holds the panels. Once the desired panel is facing out, replace the trim and reinstall the panel to the dishwasher.

NOTE: When replacing top access panel mounting screws, be sure to use the original screws. Using the wrong screw can result in a damaged tub.

INNER DOOR PANEL

For access to dispensers, switches, timer or microprocessor board and wiring, removal of the inner door panel is necessary.

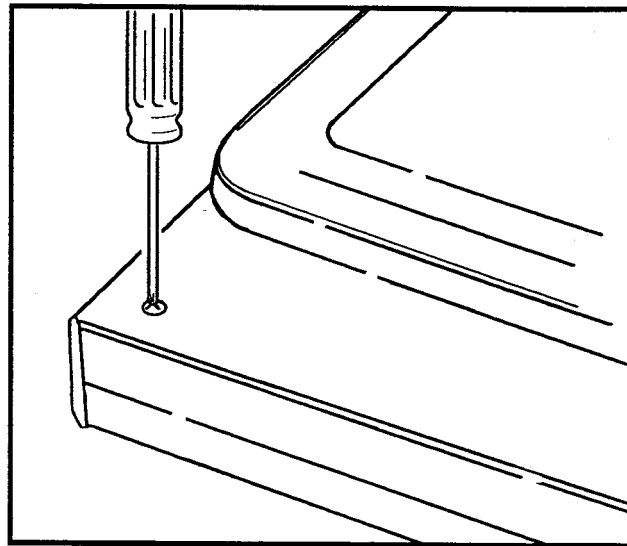

To Remove

1. Disconnect the power supply to the dishwasher.
2. Open the dishwasher door.
3. Remove the seven Torx screws along the lip of the inner door.
4. Separate inner door panel from the door assembly.
5. Disconnect wires from dispenser wax motors before pulling inner door away from dishwasher.

DISPENSER ASSEMBLY AND WAX MOTOR(S)

For access to plunger assembly, wax motor(s), latch spring and reservoir assembly. Dishwasher may have a dual or single wax motor mechanism.

To Remove

1. Disconnect the power supply to the dishwasher.
2. Remove the inner door panel.
3. For Dual Wax Motor mechanism, removal of the rinse aid reservoir is necessary. To remove, unscrew the rinse aid knob and rinse aid nut holding the reservoir to the inner door.

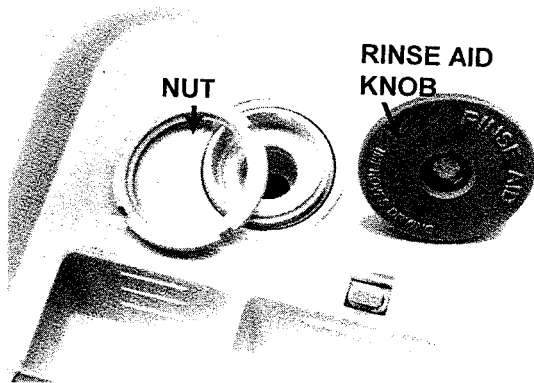

4. Remove two screws to release retainer assembly from inner door liner. This will expose the latch spring and hook assembly.

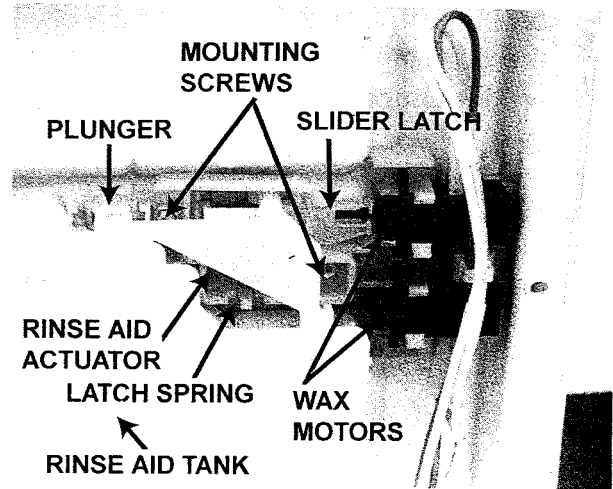

DUAL WAX MOTOR MECHANISM

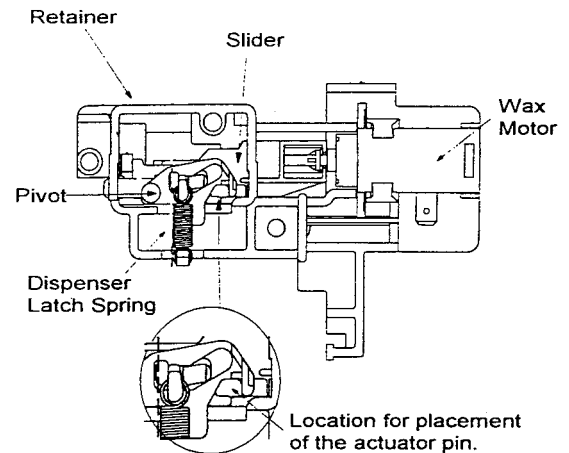

SINGLE WAX MOTOR MECHANISM

5. To check the Single Wax Motor Dispenser Mechanism alone, remove the wax motor and snap the detergent door shut. Then gently move the slider to the left till the detergent door releases. Release the slider, then slide the slider to the left again. Now the actuator will lift the rinse aid plunger. If not, proceed to next step.
6. Examine the linkage of the actuator pin to the pivot and the slider. (Note: When reassembling, the pin on the actuator should be engaged

on the left side of the armature of the pivot and into the recessed slot on the slider.

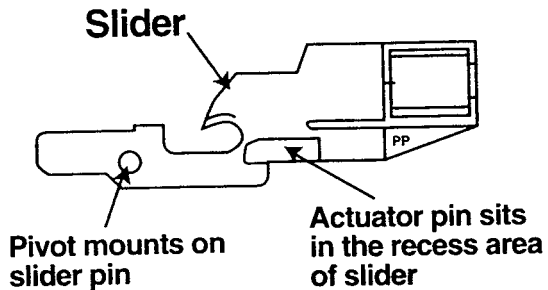

To ease reassembly, mount the actuator into the door mounted retainer assembly after the wax motor is in the retainer.

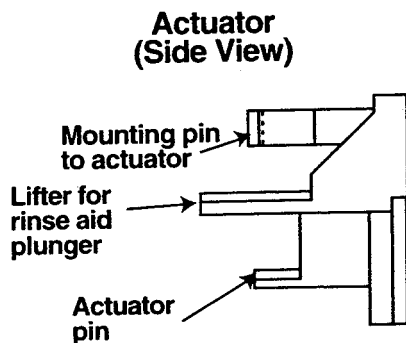
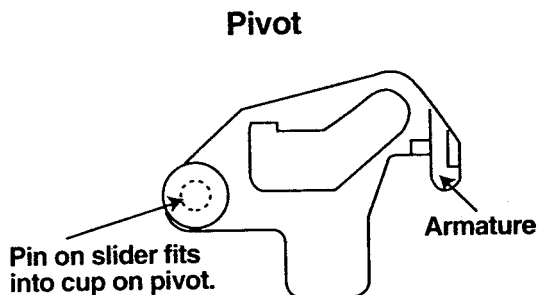

7. The plunger assembly is located on top of the reservoir. To remove, twist the plunger so the exposed tabs are clear of the retaining tabs on the reservoir. Pull the plunger from the reservoir.
8. Wax motor replacement is made by expanding the retainer tabs and sliding the motors from the tabs. When replacing the wax motors, insure the piston is securely clipped onto the dispenser actuator arms.

DOOR LATCH SWITCH HOLDER ASSEMBLY

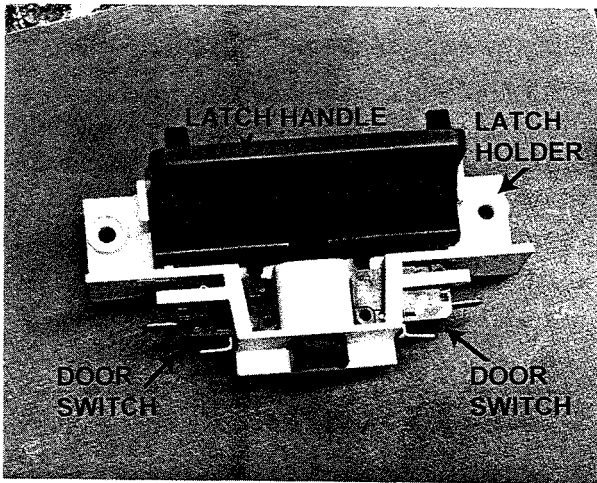

Two door switches are used in the latch assembly. Both switches are normally OPEN and will CLOSE only when engaged by the door latch hook mechanism. Each switch is in series with respective Hot or Neutral line operations. Failure of either or both switches will result in dishwasher non-operation.

Door switches require no field adjustment.

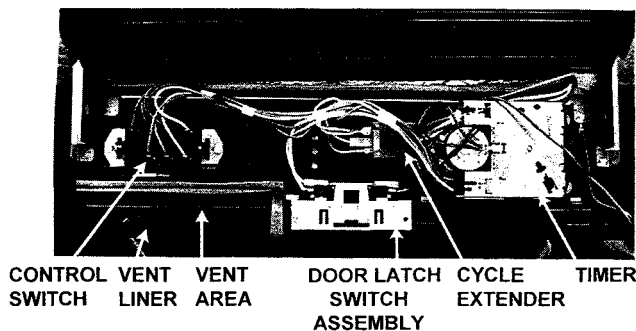

CONTROL SWITCH VENT LINER AREA DOOR LATCH SWITCH ASSEMBLY CYCLE EXTENDER TIMER

To Remove

1. Disconnect the power supply to the dishwasher.
2. Remove inner door liner. (See section titled INNER DOOR PANEL.)
3. Remove or set aside metal reinforcement strip.
4. Remove plastic barrier covering the control panel components.
5. To remove door latch switch assembly, remove mounting screw holding assembly to back of control panel. (Note screw replacement for door reassembling.)

To Disassemble

1. Disconnect the power supply to the dishwasher.
2. To remove switch, lift retainer tab behind the switch and depress the actuator button on switch. While lifting the tab, pull switch from holder. To reassemble, lift retainer tab and insert switch into holder.
3. To remove latch handle, depress two retainer tabs on switch holder then lift handle.

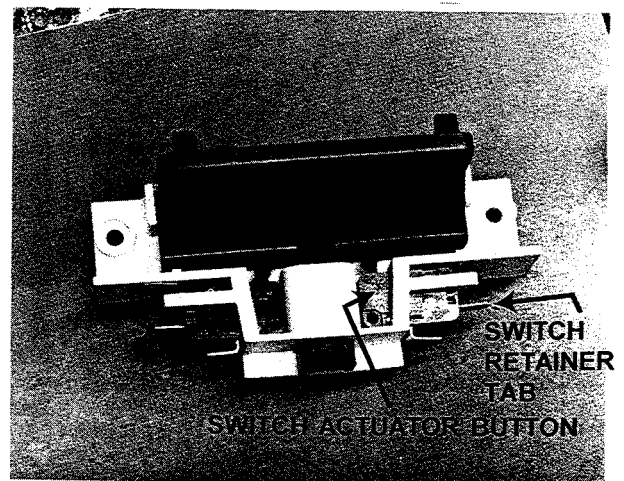

CONTROL PANEL BARRIER

Shields the control components within the control console.

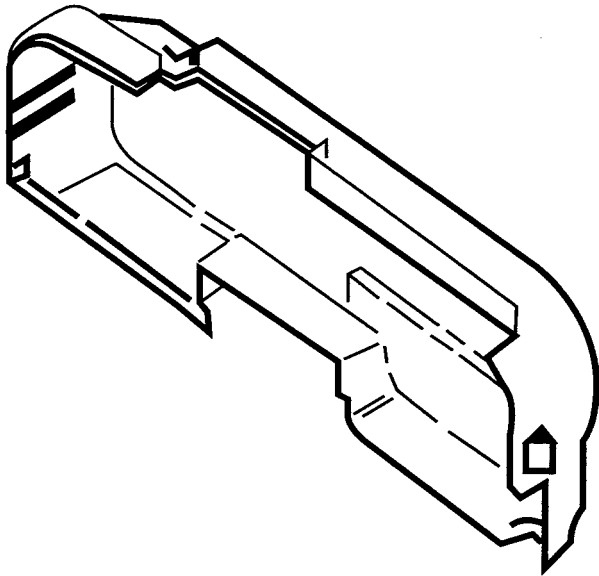

To Remove

1. Disconnect the power supply to the dishwasher.
2. Depress retainer tab on left side of barrier.
3. Then lift barrier up, left side first and disengage solid tab on right side of barrier from control panel.

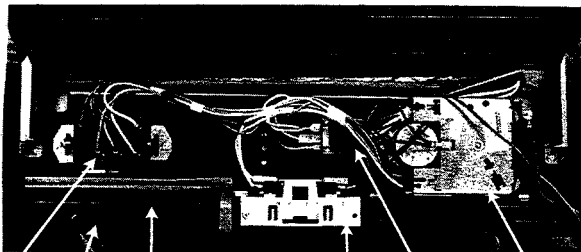

CONTROL SWITCH VENT LINER VENT AREA DOOR LATCH SWITCH ASSEMBLY CYCLE EXTENDER TIMER

CONTROL SWITCH

To Remove

Disconnect the power supply to the dishwasher.

Disconnect wire leads. (Refer to electrical schematic for proper ohm checks.) Remove hex head screw on each end of the switch.

CYCLE EXTENDER

Cycle extender is a bi-metal switch used to add approximately twenty minutes of wash in the HEAVY cycle and ten minutes in a NORMAL cycle. It is used again in the DRY cycle on select models. (For more information see ELECTRICAL-MECHANICAL TROUBLESHOOTING, section 2.)

To Remove

Disconnect the power supply to the dishwasher.

Spread retaining clips on control panel and lift cycle extender.

TIMER

The timer circuits are illustrated in the electrical schematics included in this manual. (Refer to schematic for Electrical Testing Procedures before attempting to replace timer.) **Timer must be replaced as a complete assembly.**

The **dishwasher schematic** is located behind the access panel. (See Access and Toe Panel Removal section.) The schematic diagram is unique to each model and contains the following:

- Timer Sequence Chart
- Harness Connector Identification
- Electrical Connection Diagram

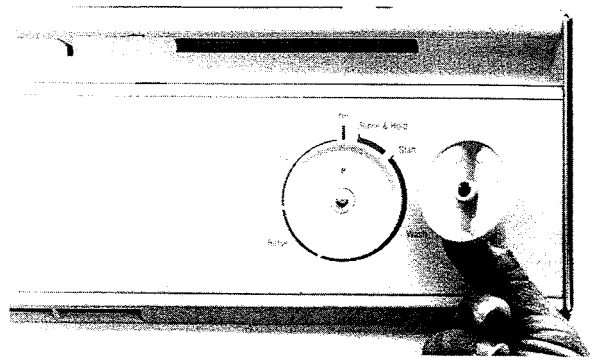

Using the Timer Sequence Chart

The sequence chart used in conjunction with an ohmmeter can be quite effective when attempting to verify or diagnose problems in the timer, wiring or other electrical components.

1. Identify cycle on chart where problem occurs.
2. Trace down on the chart the timer contacts indicated CLOSED to identify the electrical circuits involved.
3. Perform a "point to point" continuity check of the timer terminals to verify whether corresponding contacts are CLOSED or OPEN when advanced to this cycle position. If contacts do not correspond to Sequence Chart, replace timer.
4. If timer checks out good, perform a "point to point" continuity check of the timer's electrical connector. This will isolate the trouble in the wiring or the components.

To Remove Timer

1. Disconnect the power supply to the dishwasher.
2. Remove timer knob by grasping knob and sliding off "D" shaft of timer.

3. Remove three hex head screws holding timer to control panel facia.

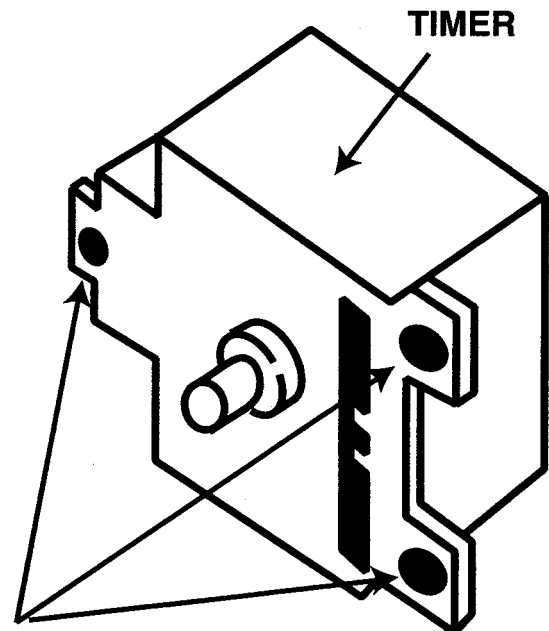

MOUNTING SCREW LOCATIONS

4. Remove the electrical disconnect block from the timer. Retainer tabs are located on each end. Squeeze the tabs while pulling to disengage from timer. Check wiring terminals in disconnect block to insure they are positioned securely.

ELECTRICAL
DISCONNECT
BLOCK

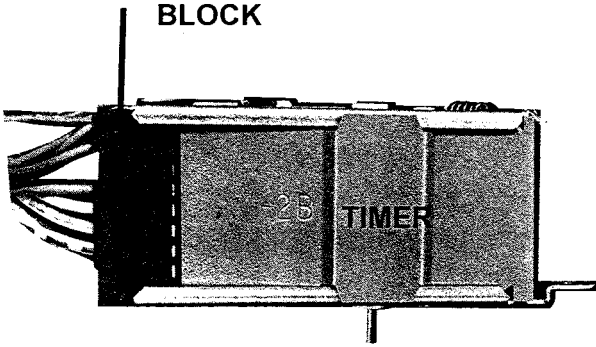

MICROPROCESSOR BOARD (On Select Models)

To Remove

1. Disconnect the power supply to the dishwasher.
2. Disconnect wire harness connector from board.
3. Remove hex head screw securing board retainer assembly to control panel.
4. Slide assembly toward screw just removed. Lift off of control panel.

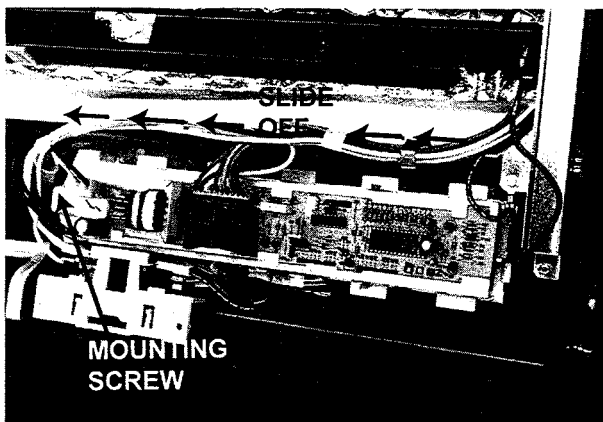

CONTROL PANEL FACIA

The inner door panel must be removed to obtain access to screws securing control panel to door panel. (See previous sections on removal of console components to gain access.)

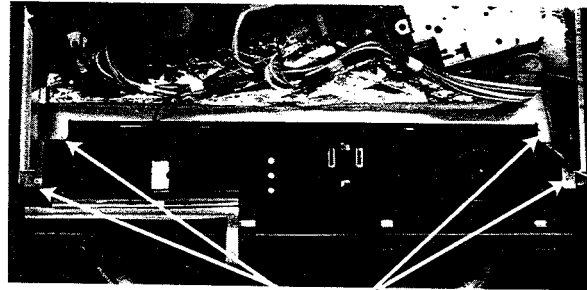

MOUNTING SCREWS

To Remove

1. Remove four hex head screws securing the control panel to the outer door.
2. Disconnect wiring to electrical components in the control panel area.
3. Remove electrical components. (i.e. Control Switch, Cycle Extender, Microprocessor and etc.)

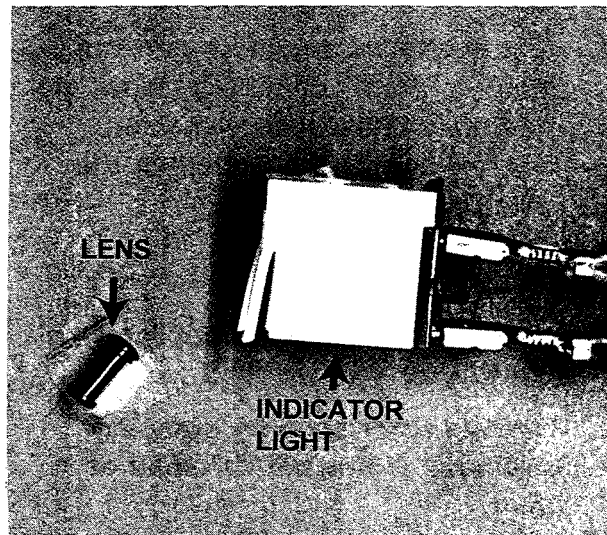

4. Remove **indicator lights** from their lenses by sliding the body of the light assembly away until it disengages from the lens. Remove lens from front of fascia.

DOOR GASKET

The door gasket provides a seal between the door and tub.

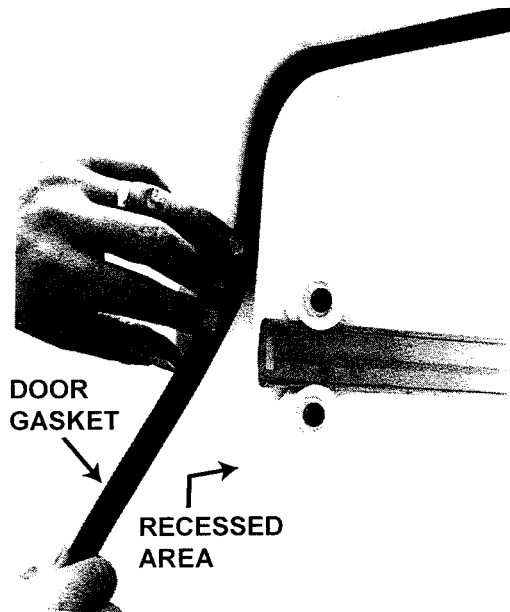

To Remove

1. Open door.
2. From lower corner, pull gasket up and out of tub recess. Note bend in gasket in right hand lower corner.

To Replace

Note: Wetting the gasket will make installation easier.

1. Start at lower right hand corner. Form a bend 1" from the end of the gasket as shown.

2. Gently work the gasket into the recess part way up the right side.
3. Begin inserting the gasket in the recess on the lower left with the end flush.
4. Work the gasket into the recess on both sides, in the corners and across the top, finishing in the center.
5. Check for proper door and latch adjustment to insure good seal of gasket.

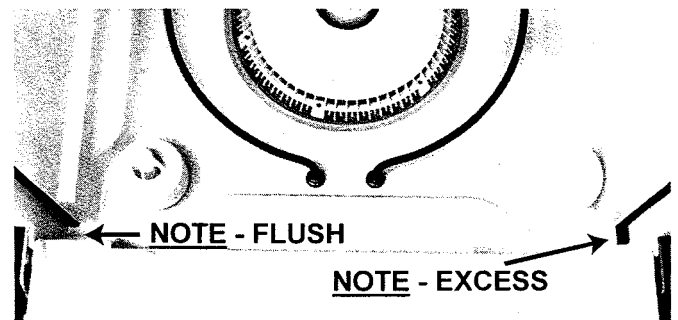

DOOR HINGES

The door hinge screws are used to adjust complete door assembly to dishwasher tub front. Insures good seal of door gasket to inner door liner.

To Adjust

1. Remove side trim strips from door assembly and loosen hinge screws.
2. Latch the door with the hinge screws loose.

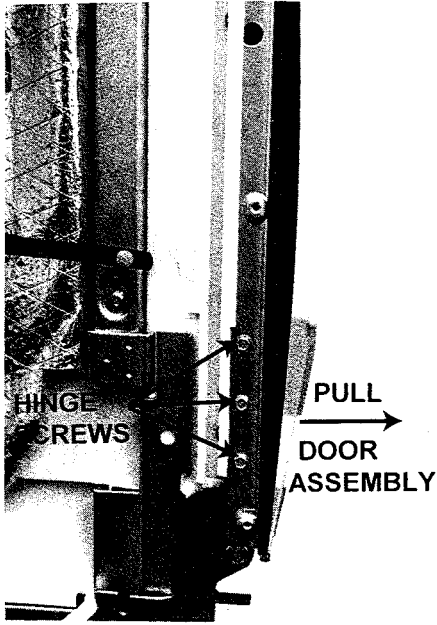

DOOR LATCH STRIKE

The door latch serves as a "TENSION" lever for proper door seal. It also provides the mechanical actuator for door switch operation.

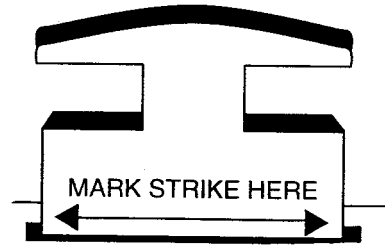

3. Pull the bottom of the door away from the tub as far as it will go.
4. Tighten the screws very tight (75 in. lb. minimum) to insure they will not loosen.
5. Adjust door latch strike for low door closure force. Check door liner placement by chalking the liner with chalk or talcum powder, then close. Upon opening, the chalk line will indicate door liner placement onto the gasket. Make necessary adjustments to door strike and door assembly for center placement on gasket.

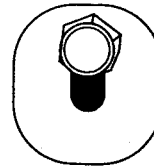

To Adjust Door Strike

1. Mark "underside" of the door strike prior to adjustment. This will provide a guide to make accurate "in" or "out" adjustment.
2. Loosen hex screw securing strike assembly to tub. Slide strike "in" to INCREASE tension on door and door seal. Moving "out" will DECREASE tension.

HINGE SPRINGS

The hinge springs provide a counter balance to the weight of the door.

The door spring is inserted through the offset portion of the link, with the offset of the link positioned toward the dishwasher. The other end of the link is mounted into the appropriate slot of the hinge.

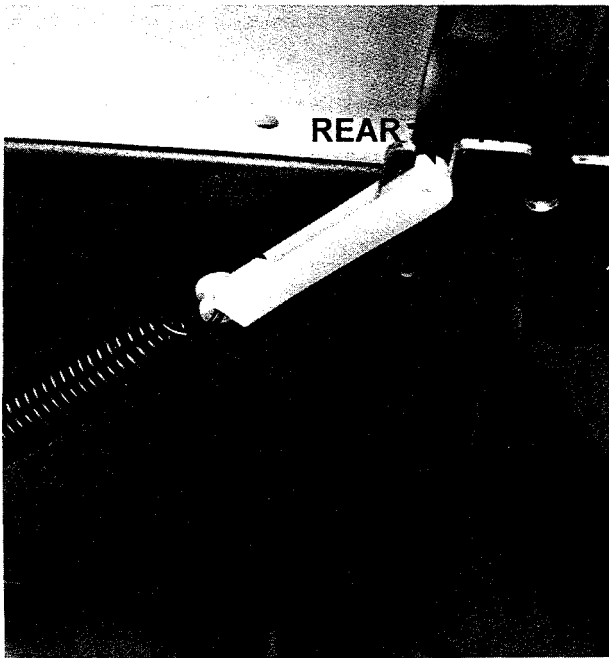

Timer Models The left spring link is mounted in the rear notch and the right link is mounted into the front notch of the hinge.

Microprocessor Models Both links are mounted in the front notch of the door hinge.

The bottom end of the spring is hooked in the hole of the adjustment bracket. (Always point the spring hooks toward the dishwasher.)



Door spring adjustment brackets are located behind the toe panel, on the right and left side. They stretch the springs by sliding forward and back along the dishwasher tub support. To change door spring tension, use a 1/4" hex-nut driver.

To Adjust

1. **Increase Spring Tension:** Turn the adjustment screw in a clockwise direction.
2. **Decrease Spring Tension:** Turn the adjustment screw in a counter-clockwise direction.
3. Adjust the springs equally. Failure to do so may lead to a "twisted" condition of the door.

Proper Door Spring Tension

The proper setting is when the door will remain open to a minimum of 6" (measured from tub flange to top of door). When opened slightly farther, the door will fall at a slow rate and come to rest horizontally or up to 3" above horizontal. The door should not fall so fast as to "bounce" when fully open.

Heavy Decorator Panels may make it necessary to relocate the door spring

link to the rear notch on both springs. This will enhance the spring tension. Check door again for proper tension.

An Auxiliary Spring Kit is available to handle up to 12 lbs. of door weight.

UPPER WASH ARM

To Remove

Unscrew spin nut above the wash arm.

To Replace

Screw spin nut onto the upper spray hose.

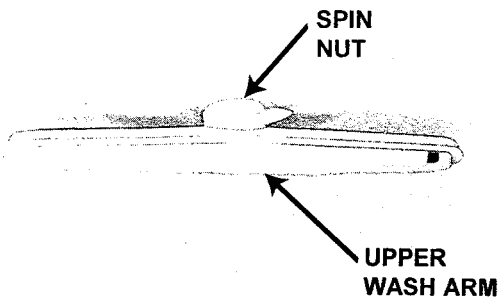

UPPER WASH ARM HOSE

Water is supplied to the upper wash arm through this hose via the pump assembly. The hose runs away from the pump then vertically up the right side of the dishwasher tub and enters above the upper wash arm. The outlet of the hose is sealed to the tub with a sealing washer between the hose and

the tub. The seal is compressed to the tub via the spin nut of the upper wash arm.



To Remove

1. Disconnect the power supply to the dishwasher.
2. Undercounter models: Remove the unit from under the counter.
Convertible models: Remove the cabinet and wood top. (See section devoted to convertible models.)
3. Remove access and toe panels.
4. Loosen hose clamp securing upper wash arm hose to pump and remove hose. Use a bowl or towel to catch the water that comes out.
5. Remove upper wash arm assembly.
6. Remove upper wash arm hose from unit.
7. Reinstall hose assembly with seal washer to top of tub. Insure seal washer is properly positioned between hose assembly and top opening in tub.
8. Reconnect hose assembly to pump. Insure rubber coupler of outlet assembly is fully inserted onto the outlet of pump and re-tighten hose clamp.

FLOAT ASSEMBLY

The float assembly is a protection device against an overflow situation. Water fill is normally controlled by the timer or microprocessor.

The float switch is wired in series with the water valve. When the float switch OPENS, the electrical circuit to the water valve is OPENED and the valve shuts off.

Normal Fill is just below the heating element in the basin of the tub assembly.

The float assembly consists of a float, float switch, actuator lever and a float switch bracket.

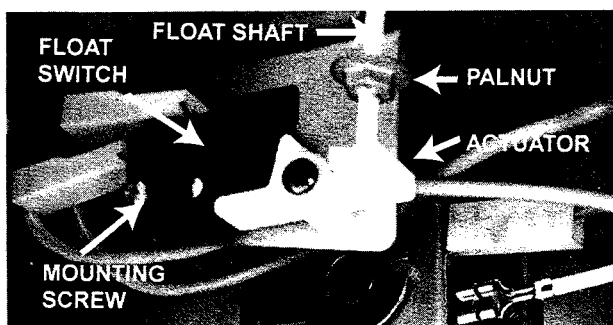

To Remove

1. Disconnect the power supply to the dishwasher.
2. Remove access and toe panels. (See section on removal of ACCESS AND TOE PANELS.)
3. Within the access panel area, reach inside and remove the palnut from

the float shaft. Do this by grasping palnut in one hand and turn the float counter-clockwise with the other. CAUTION: Replace float if end of shaft twists off.

4. Lift the float up and out of the float guide.
5. To remove actuator, remove mounting screw from bracket.
6. To remove float switch, remove one screw mounting switch to bracket. Then remove wire leads to switch.
7. To remove bracket, remove two screws mounting switch assembly to tub support base.

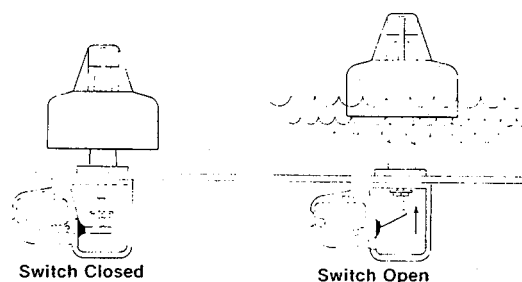

To Check Float Switch

Perform continuity check of switch across wire terminals.

CLOSED - Switch actuator depressed.

OPEN - Switch actuator released.

VENT COVER

The vent cover is located in the front lower right corner of the dishwasher tub.

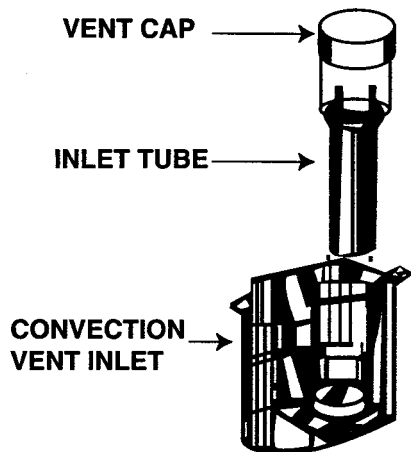
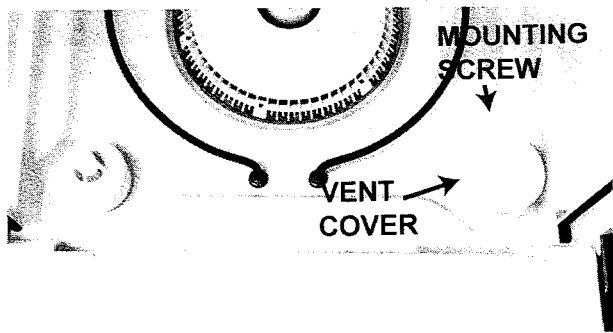

To Remove

1. Disconnect the power supply to the dishwasher.
2. Remove access and toe panels. (See section on ACCESS AND TOE PANEL removal.)
3. Remove the Vent Cover inside the right front area of the dishwasher tub.
4. Lift the plastic tube within the vent area vertically from the Suds Reservoir.
5. Down in the access area, in front of the Suds Reservoir, remove the mounting screw.
6. Carefully lower the front of the Suds Reservoir slightly and pull the reservoir toward you. A retaining tab on the reservoir fits into a slot in the ceiling of the tub support.

To Remove

1. Remove lower dishrack from dishwasher.
2. Remove one Torx screw. Then lift cover from tub basin.

SUDS RESERVOIR/CONVECTION VENT INLET

The suds reservoir is located below the vent cover and housed below the tub within the access panel area. The purpose of this component is two fold. To collect excess suds generated during the Wash cycle and provide an air inlet for convection drying during the Dry cycle.

START RELAY

Location of the start relay is in the access panel area on the front right side of the tub support ceiling. The relay is mounted to a bracket with one screw.

The start relay is a mechanism used to provide a direct electrical (Neutral) path to the START winding in the motor. This allows the motor to start. Once the motor gets up to operating speed, the current draw of the motor reduces. This reduction in current causes a drop in the magnetic field of the relay coil and the mechanism drops down and the switch then OPENS, thus taking the START windings out of the circuit.

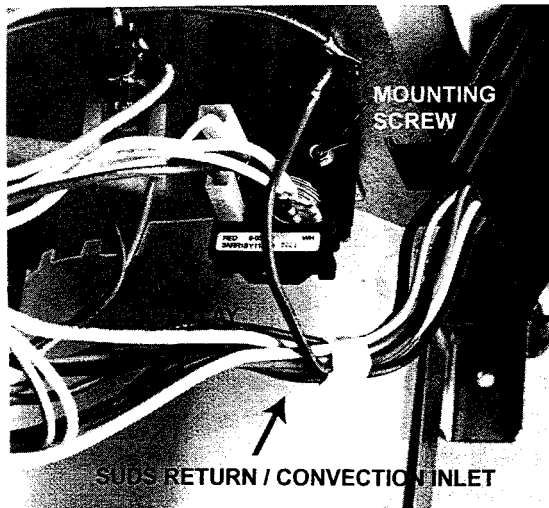

Note: The relay must be mounted in an up right vertical position. Positioning of the relay is very important. (See illustration.)

Start Relay Checks

1. Disconnect the power supply to the dishwasher.
2. Remove relay wiring and mounting screw.
3. Hold relay in upright position and check continuity across Yellow and White terminals. You should see continuity, if not replace relay switch.
4. Rotate relay switch upside down and check continuity across Red and Yellow, then Red and White. You should see continuity across both sets of terminals, if not replace relay switch.

HEATING ELEMENT

The purpose of the element is to provide heat during the dry cycle if heated dry is selected and increase the water temperature during the wash cycle.

The heating element is rated at 650 Watts.

To Check Heating Element

1. Disconnect the power supply to the dishwasher.
2. Access the element wiring terminals through the access panel area. (See section on removal of ACCESS AND TOE PANEL.)
3. Perform continuity check across the element terminals. The element should be approximately 22 ohms. If OPEN, replace the element.
4. Perform continuity check from each terminal to element sheath. Should show no continuity present. If continuity present, replace element.

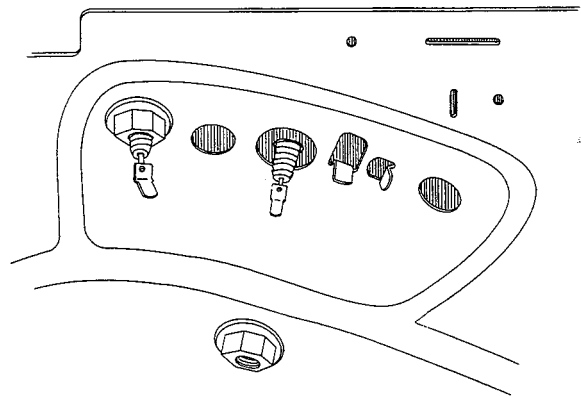

To Remove

1. Disconnect the power supply to the dishwasher.
2. Remove wires from element terminals.
3. Remove mounting nuts securing heating element to tub.

Note: With new heater brackets (started production in mid-August

1994) top end of bracket must be pried loose from the tub.

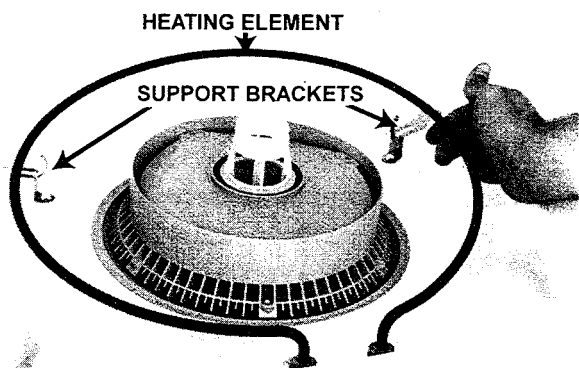

(Support Brackets shown above are prior to August 1994 production.)

4. Release the element from the two rear heater supports. To release, pull the ends through the tub and push element back.
5. Then lift the element out of the tub.
6. Examine condition of the sealing "O" rings sandwiched between the element leads and tub basin. Replace "O" rings if damaged or stressed.

Wattage Checks

If specific wattage reading is needed, take an amperage reading at YL-BK wire of heating element. Multiply the reading by available voltage. (Amps x Voltage = Wattage)

Normal element amperage during the dry cycle is 5.0 to 5.5 amps.

THERMOSTATS

Two types of thermostats are used in the dishwashers.

One thermostat is used to sense water temperature toward the end of the wash cycle. If the water temperature is too cool, the "Heating Delay" lamp will inhibit current flow to the timer motor. This will suspend the unit in the wash cycle till the heating element brings the water temperature up to 130°-140° F. The water temp thermostat is a normally OPEN thermostat below 125° F and has 3/16" terminals. It is located in the access panel area, mounted to the tub support between the heating element terminals.

The other thermostat is used as a protective device to sense overheating by the heating element. This thermostat is located in the access panel area mounted to the tub support ceiling, on the right front area. The thermostat is a normally CLOSED switch up to 145° F and has 1/4" terminals. It's designed to OPEN if the water temperature exceeds 160° F.

To Remove (One Piece Bracket)

1. Disconnect the power supply to the dishwasher.
2. Pull down on tab and slide thermostat from recessed area in tub support ceiling.

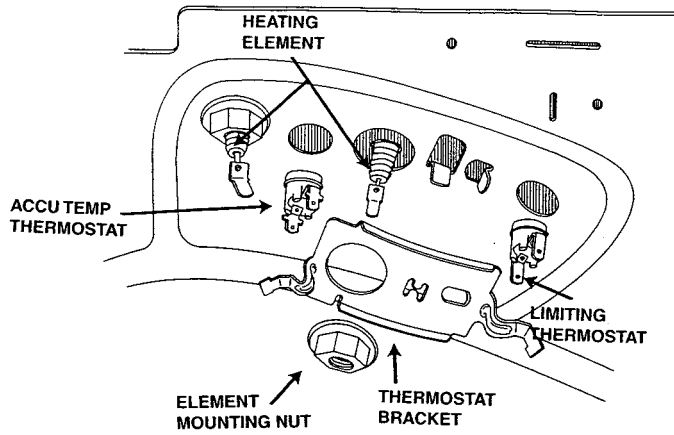

3. Remove wires from terminals.

Water Temp 3/16" terminals
 Hi-Limit 1/4" terminals

To Remove (Two Brackets)

1. Pull out on spring tab to release thermostat and bracket from slots in tub ceiling.
2. Remove wires from thermostat.
NOTE: Terminal sizes of thermostat and location of thermostats.

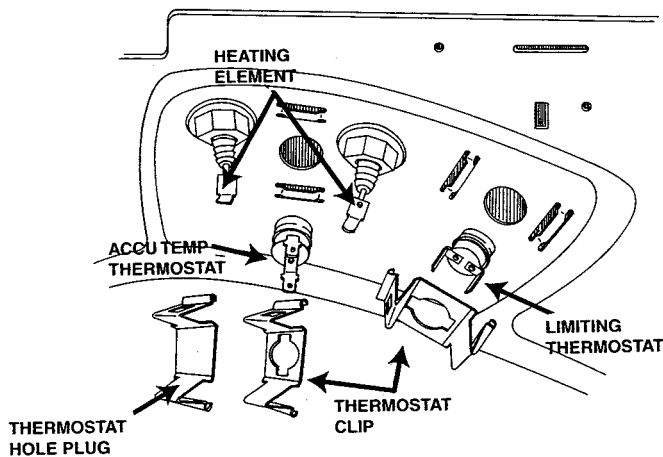

WATER VALVE

The valve is located in the access panel area and mounted to the left side of the tub support. Inlet water supply to valve is directly below the valve. (Turn off water to the dishwasher when servicing this area.)

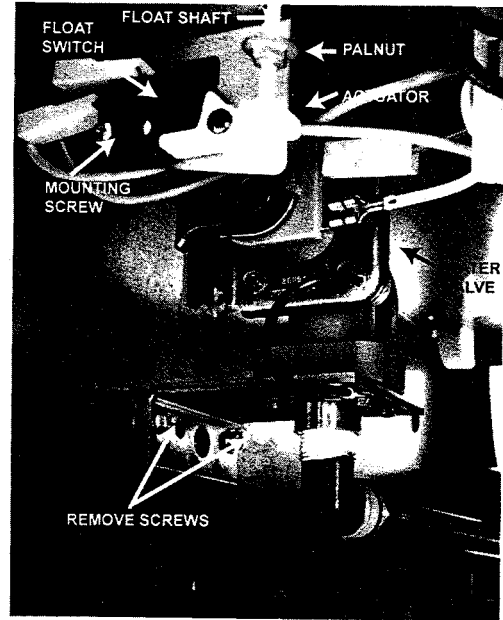

All models covered in this manual use a TIMED FILL system. The timed fill will supply approximately 1 1/2 gallons of water. Proper water level is 1/2" below the heating element.

The valve is designed to operate at water pressures of 18 - 120 psi. **NOTE:** Low water pressure will affect the ability of water valve to fill the tub within the required length of time.

The water temperature should be a minimum of 120° F. However, higher water temperatures may provide enhanced washing and drying results.

The "overflow" protection device for a timed fill system is the Float Switch. (See section on FLOAT SWITCH for more information.)

To Remove

1. Disconnect the power supply to the dishwasher.
2. Remove access and toe panels. (See section on removal of ACCESS AND TOE PANELS.)
3. Shut off water supply to dishwasher.
4. Remove wires from water valve solenoid.
5. Remove two mounting screws securing water valve to the tub support.
6. Disconnect injector hose at valve outlet.

Note: This is a **non-repairable water valve**. The only servicing required is to clean the inlet screen.

To Clean Inlet Screen

Sediment on the inlet screen can hinder water flow through the valve within the required length of time for fill.

1. Disconnect the power supply to the dishwasher.
2. Remove water valve from dishwasher.

3. Remove four screws securing valve body to water inlet mounting bracket.



4. Clean screen.
5. Reassemble valve body to mounting plate and reattach ground wire to mounting bracket.

Check Valve Operation

1. **NO FILL:** Perform continuity check across the valve solenoid. (Proper resistance reading will be approximately 900 ohms.) If OPEN, replace valve. Alternate Test: Use motor test cord hooked directly to the water valve. Turn on water supply and plug-in test cord. Still no water - replace valve.
2. **OVERFILL:** If valve allows flow without power to solenoid, replace valve.

WATER INJECTOR

The injector is located in left rear corner of the tub and mounted to the exterior of the tub. Removal requires removal of the dishwasher from installation or cabinet removal on portable units.

To Remove

1. On select models carefully peel insulation from the left exterior rear corner area of tub. Then gently lift insulation to expose the injector.
2. Untuck the injector hoses from the recess on side of tub assembly.
3. Grasp the upper portion of injector and pull away from tub, while rotating the injector in a clockwise direction to the two-o'clock position. (This will allow passage over the "ramp" protruding from the tub wall.) Note: Examine seal washer between injector and tub wall.

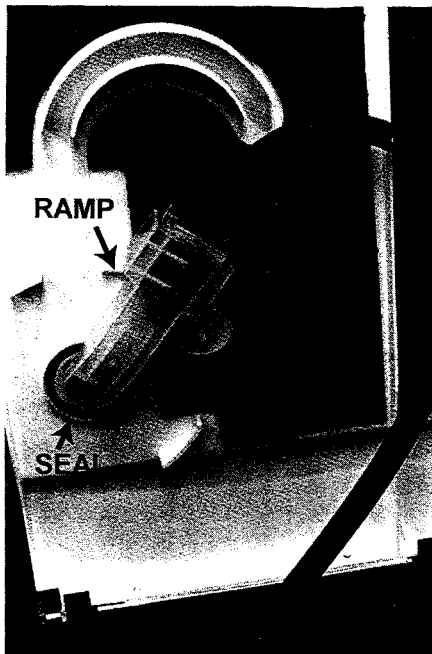

To Reinstall

1. Position injector at two-o'clock and rotate counter-clockwise while pressing inward. Injector will slide "up the ramp" then snap into position.
2. Return injector hose to recess in tub wall.
3. Return insulation wrap over area and tape down.

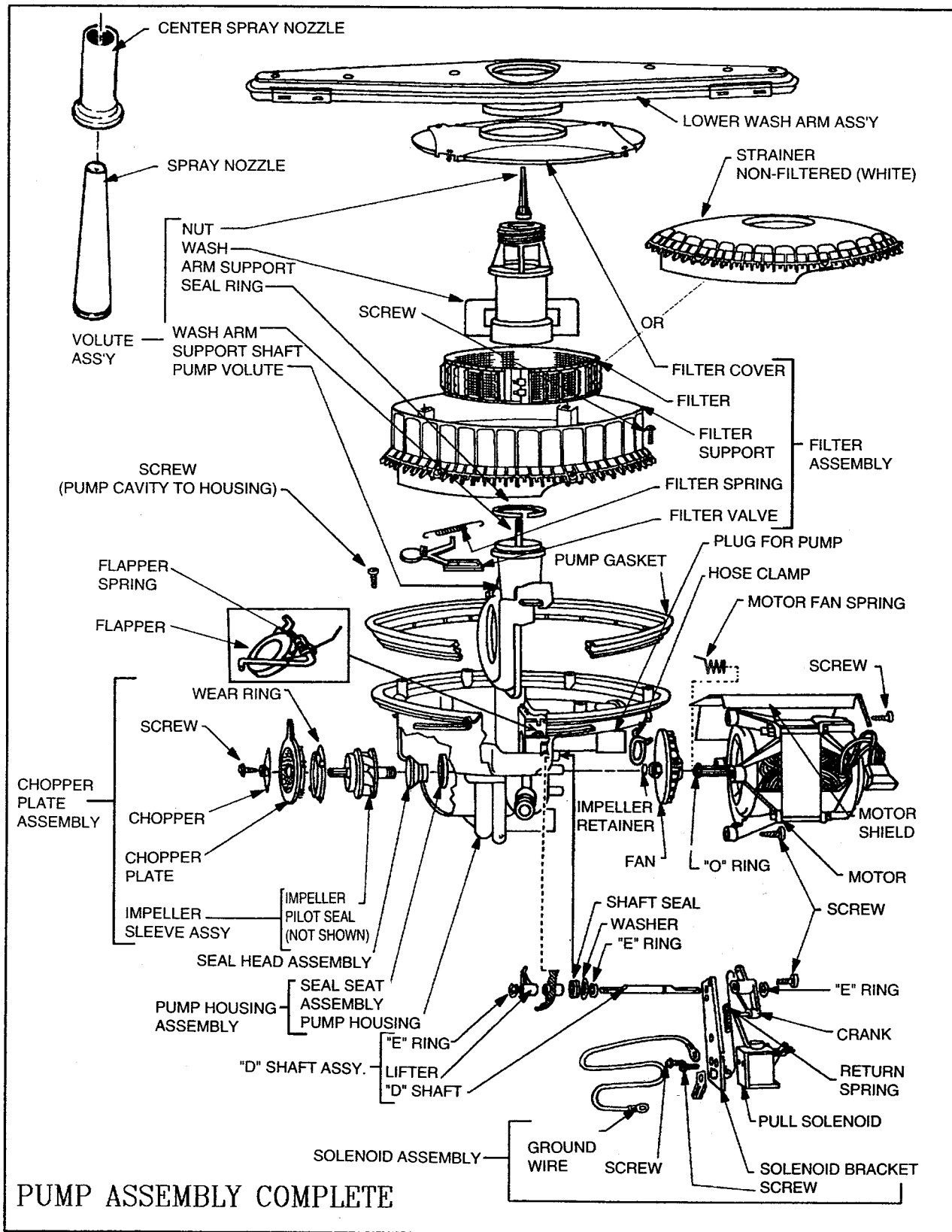

PUMP ASSEMBLY

The pump assembly consists of a drain solenoid, pump and electric motor combined to provide drain and recirculating functions for the dishwasher cycles. If a failure is detected inside the pump assembly, individual parts in the pump should be replaced.

Some repairs may be made to the assembly while still in the dishwasher. However, for ease of service, removal of the pump and motor assembly has been simplified.

To Remove

1. Disconnect the power supply to the dishwasher.
2. Remove lower rack assembly.
3. While holding the lower spray arm, unscrew center wash tower. The remove tower and spray arm.

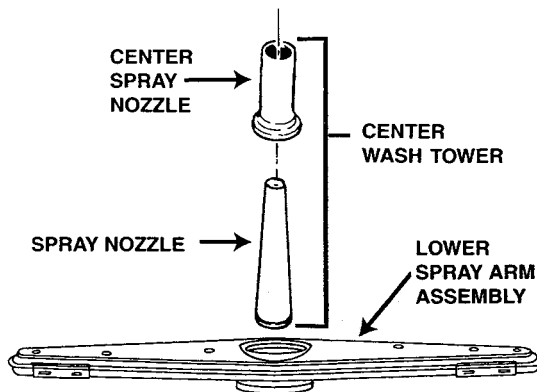

4. Remove access and toe panels. (See section on ACCESS AND TOE PANELS.)
5. Loosen drain hose clamp (from side of pump) and disconnect drain hose from pump housing. Use a bowl or towel to catch about 1 pint of water that will come out.
6. Loosen upper wash arm hose clamp (right side of pump housing) and disconnect hose from pump. NOTE: Models without the upper wash arm hose, a hose plug and clamp is installed on the pump assembly outlet. The hose plug does not need to be removed to lift pump assembly from dishwashers.
7. Disconnect wire harness connector from drive motor.
8. Remove Green ground wire leading from drain solenoid bracket to tub support. This is done by removing the front screw on the tub support.
9. Disconnect wire harness from drain solenoid.

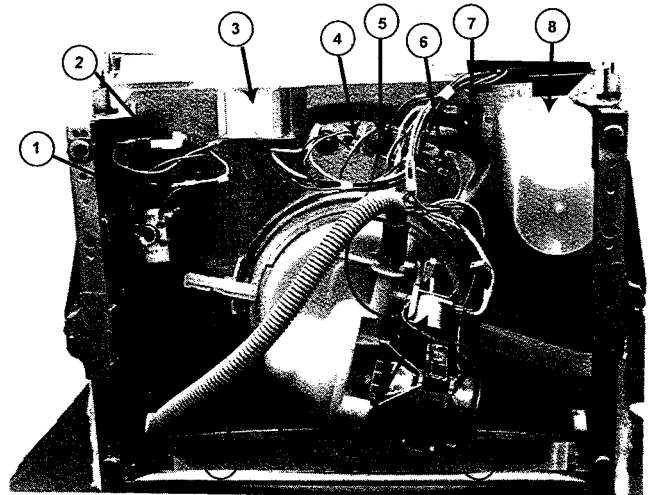

- | | | |
|-------------------------|------------------------|-------------------------|
| 1. Water Valve | 6. Hi-Limit Thermostat | 11. Drain Solenoid |
| 2. Float Assembly | 7. Start Relay | 12. Pump Housing |
| 3. Junction Box | 8. Suds Reservoir | 13. Drain Hose |
| 4. Accu-Temp Thermostat | 9. Upper Spray Arm | 14. Clamp Ring Handle |
| 5. Heating Element | 10. Motor | 15. Water Injector Hose |

10. Gently pull the clamping ring handle (left side of pump) downward and push toward the rear of the dishwasher. Clamping ring tab

should align with detent in opening of tub support ceiling.

11. Lift assembly 3/4", then tilt right side down to allow motor assembly to clear tub opening. Continue to lift assembly clear of dishwasher tub and remove from dishwasher.

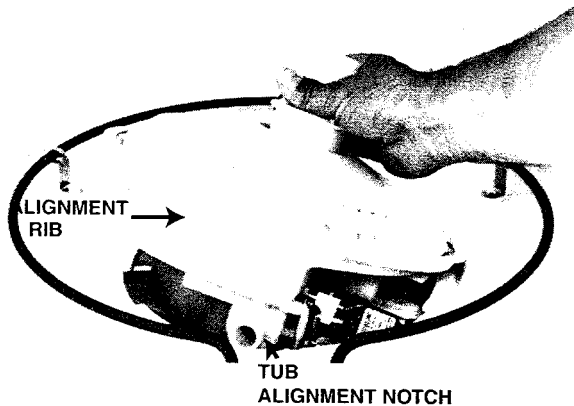

Chopper Plate Assembly

Remove **Chopper Plate Assembly** with pump impeller and seal. **Note:** Center shaft of the pump impeller is splined to fit onto the motor shaft and screwed into the motor fan.

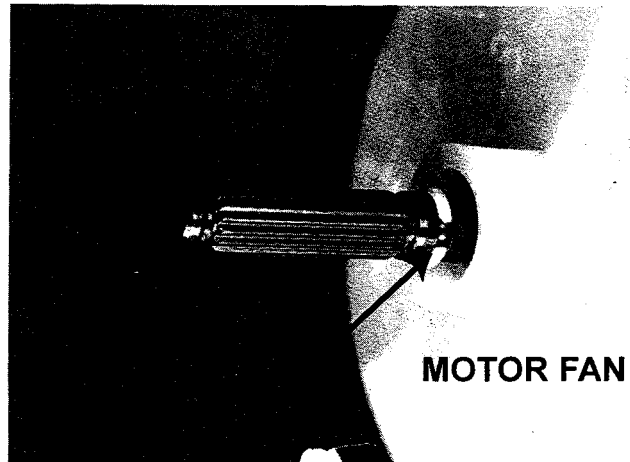

To Disassemble

1. Remove 3 Torx screws securing strainer to pump housing. **Note:** Orientation of cover requires the lower flange to sit into the deep reservoir of the pump housing.

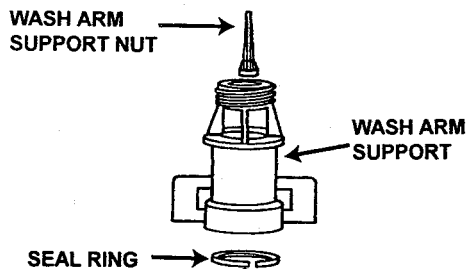

2. Unscrew wash arm support nut from pump volute, then lift to remove. To reinstall, reposition seal ring into the lower hub of the wash arm support prior to remounting onto pump volute.

1. With one hand, hold the chopper blade and with other hand rotate motor fan counter-clockwise (looking from shaft end). This is a left hand thread. Continue until fan is released from impeller hub.

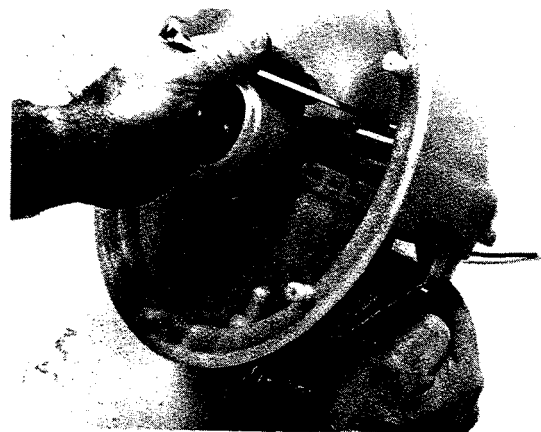

2. To remove assembly from housing, grasp tab on chopper plate pulling

outward while rotating clockwise. Once chopper plate is disengaged from pump housing, pull assembly outwardly, yet firmly to slide assembly off motor shaft. For reinstallation, reverse procedure.

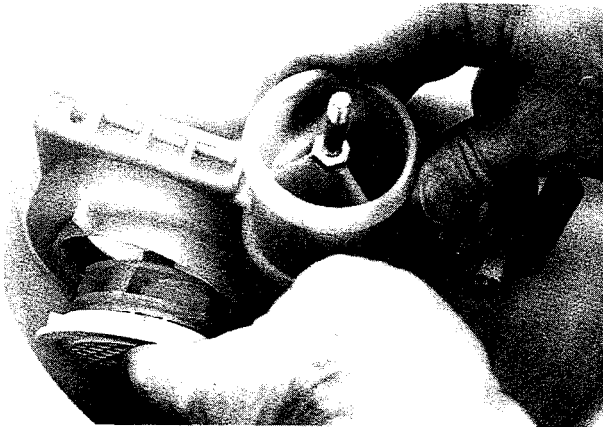

3. To disassemble Chopper Plate Assembly, remove chopper blade mounting screw, then separate chopper plate, wear ring and impeller with seal. **Note:** Wear ring tabs to be located between vertical ribs on chopper plate.

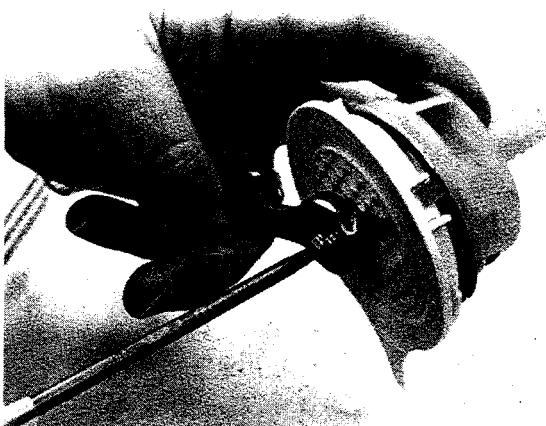

4. When reinstalling impeller with seal, the seal must be seated squarely in

the impeller. This will prevent water leaks. Carbon ring should always be clean.

Do not lubricate carbon ring. (Replacement pump impeller includes new seal.)

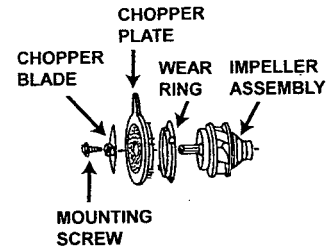

Volute

Volute removal. Remove 3 torx screws securing pump volute. Lift volute upward away from pump housing. Drain flapper and water seal seat in pump assembly are now accessible.

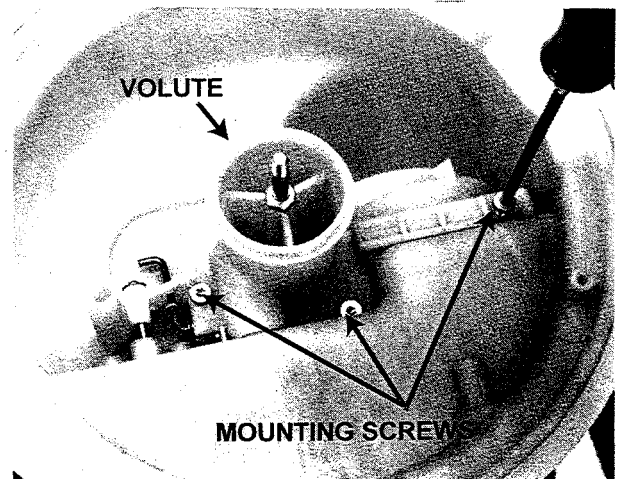

Drain Flapper

Drain Flapper assembly removal. Note: The hook end of the spring is over long arm of the drain flapper. The straight end of spring should be on the side of

the small vertical pump housing rib - side closest to standpipe.

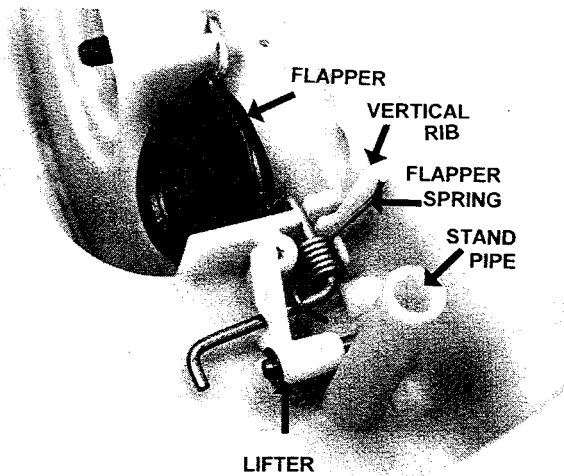

the recess, check visually for complete sealing through the slots behind the seal seat. Note: A water leak may occur if seal is not down all the way or is not resting squarely in the housing recess.

Drain Solenoid and Lifter Assembly

Drain Solenoid and Lifter Assembly removal.

Water Seal Seat

Water Seal Seat removal. For ease of service removal of the motor is necessary. (See MOTOR ASSEMBLY removal.)

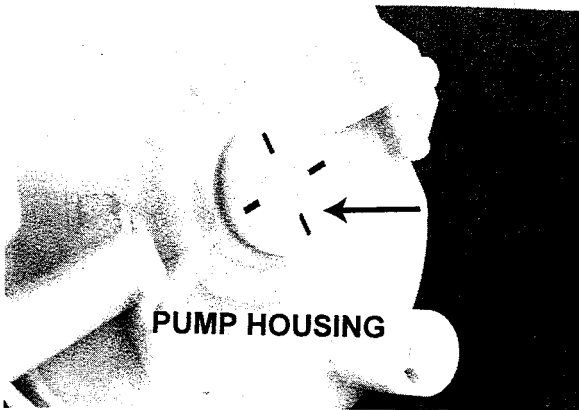
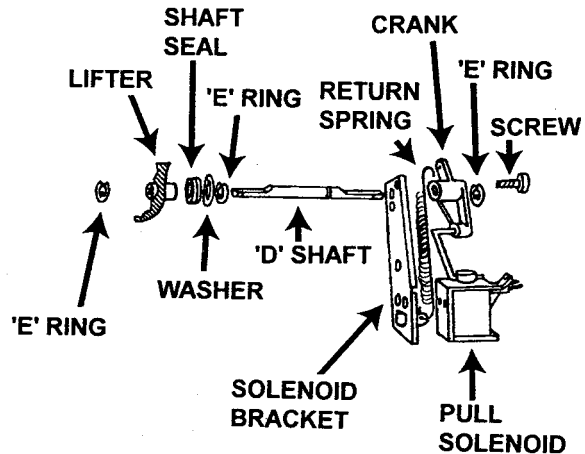

1. Disconnect Return Spring from Crank.
2. Remove stainless "E" clip securing Crank to "D" Shaft. Then remove Crank.
3. Remove 3 Torx screws securing Solenoid Bracket to Pump Housing.
4. Remove (Yellow) Chromate "E" Ring and Washer from "D" Shaft. NOTE: The other "E" rings are stainless steel. IMPORTANT TO REPLACE IN CORRECT ORDER TO PREVENT CORROSION.
5. Push "D" Shaft into pump housing and remove shaft. (Note orientation of Lifter.)

DO NOT USE OIL OR OTHER LUBRICANTS ON SEAL SEAT SURFACES. If lubricant is required, use water. Insure seal seat is all the way in

- Remove remaining "E" Ring from "D" Shaft to remove Lifter.

Motor

Motor removal. (See section on CHOPPER PLATE removal.)

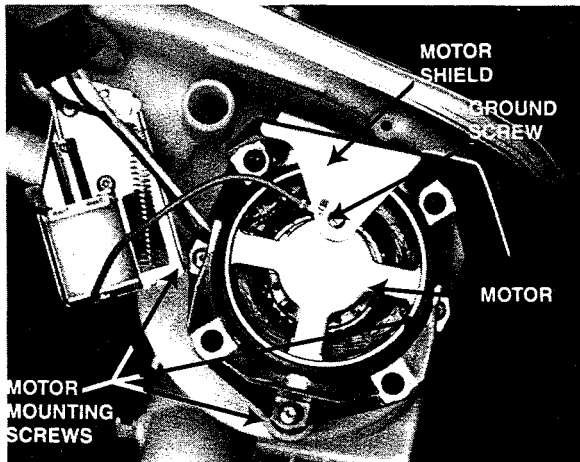

- Remove ground screw from motor shield and remove ground wire and shield.
- Remove 4 mounting screws securing motor to pump housing.
- Reinstallation of the motor requires proper centering of the motor shaft. **Note: To do this, the Chopper Plate assembly with impeller must be in position.**

A. Align motor screw mounting holes with holes in pump housing. Then slide motor shaft into center of the drain impeller assembly. Then screw the 4 motor mounting screws into pump housing.

B. While keeping the Chopper Blade from turning, lightly push the motor fan toward the drain impeller and rotate the motor fan in a counter-clockwise direction.

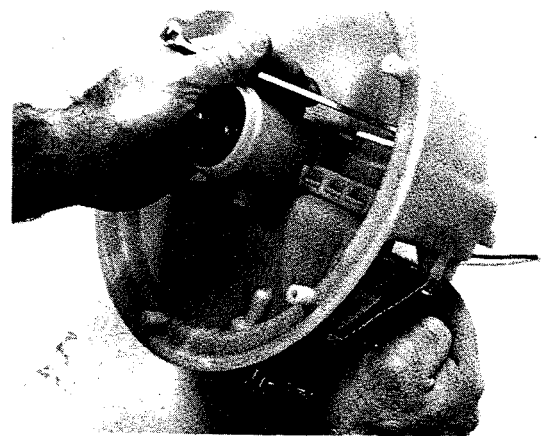

Replacement motors will be provided with new fan, collar, "O" ring and fan spring already assembled to motor shaft.

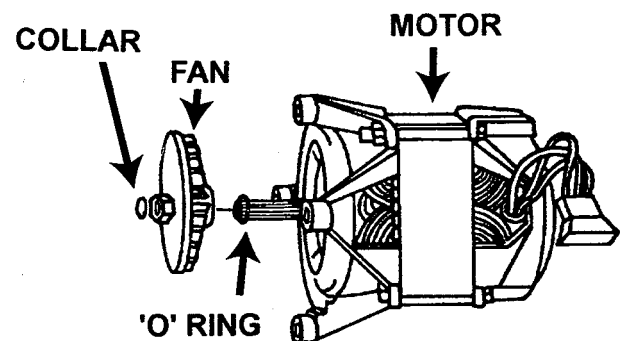

REPLACEMENT MOTOR ASSEMBLY

To Reinstall Pump Assembly

- Check proper engagement of gasket to pump housing prior to reinstallation of pump assembly to dishwasher.
- Check positioning of clamping ring. Move ring forward between the tub and tub support to allow alignment rib on housing to clear. Position tab on ring to align with the detent on the tub support ceiling.

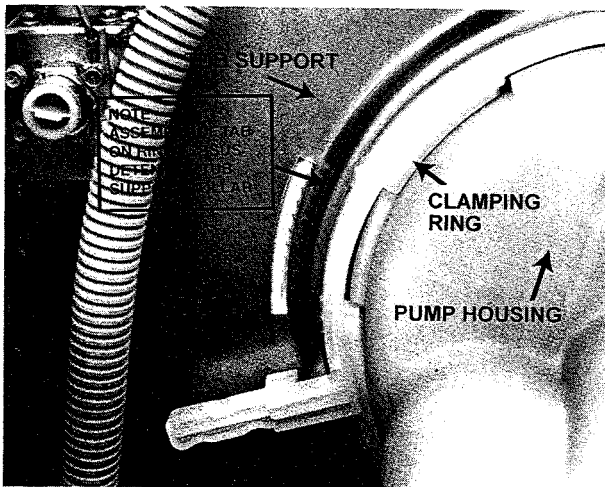

3. Tilt motor assembly of pump into opening first.
4. Position the alignment rib on the front of the pump housing with the notch in the tub opening.

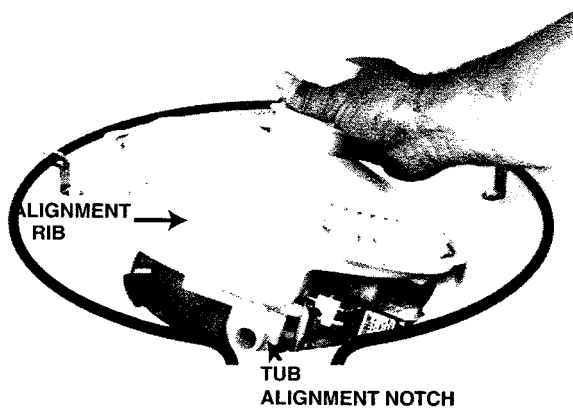

Then lower the pump assembly down into the opening.

5. Pull down on clamping ring handle and pull forward to lock handle on ribs protruding down from tub support ceiling. Pump assembly will be drawn down and compress pump gasket to dishwasher tub.
6. Grasp pump assembly inside dishwasher and check tightness of

pump to tub. If necessary, loosen locking ring and reposition pump.

UPPER RACK REMOVAL

1. To remove the front rack rail retainer, use the handle of a screwdriver and press the handle on the outside edge of the retainer.



2. Then roll inward toward the rack while pressing on the retainer. This will disengage the locking tab from the rail. Slide the retainer from the rail. Do this for both rails.
3. Remove upper rack.

RACK ROLLERS - Tub Wall

1. To remove, partially unscrew roller mounting screw. Use end of torx driver against side wall of roller and press roller back against tub wall. This will disengage steel washer from shoulder on mounting screw behind roller.

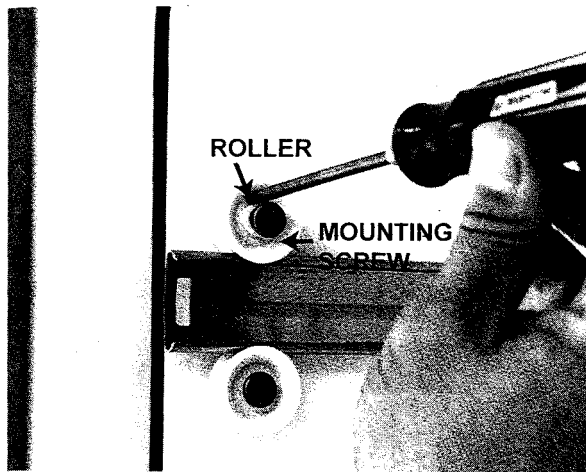

2. Finish removing roller mounting screw. **Note:** Use caution when removing screw so as not to lose the steel washer behind the roller.

PORTABLE DISHWASHERS

Wood Top

These models use a top made of wood composition core with hardwood laminated strips permanently bonded to the top and edges. Periodic treating of the laminated top with a non-toxic mineral oil is recommended.

To Remove

1. Remove two screws securing wood top to mounting flanges positioned under the top in front of tub.

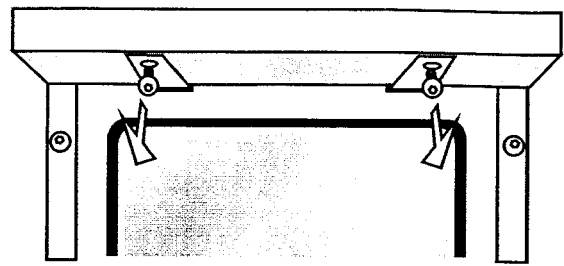

2. Carefully slide wood top forward to disengage spacer washers from slots in rear cabinet flange.

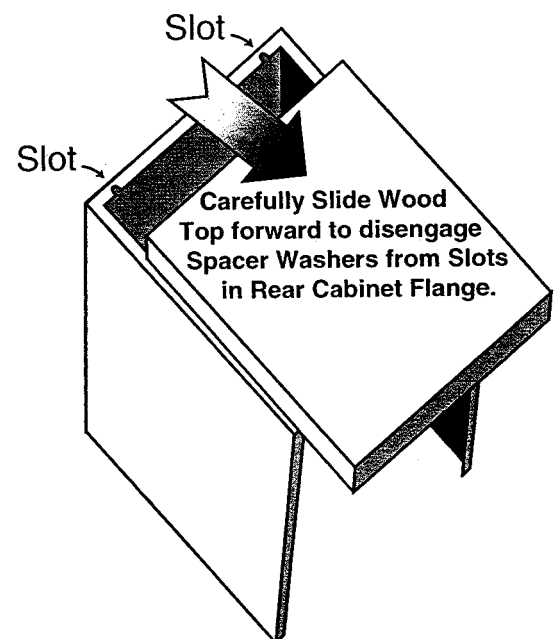

Cabinet

To Remove

1. Remove wood top. (See section on Wood Top removal.)
2. Remove access and toe panels. (See section on Access & Toe Panel removal.)

- Remove front and rear cabinet screws securing cabinet to tub and base supports.

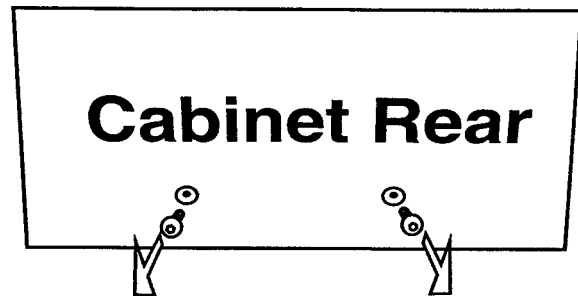
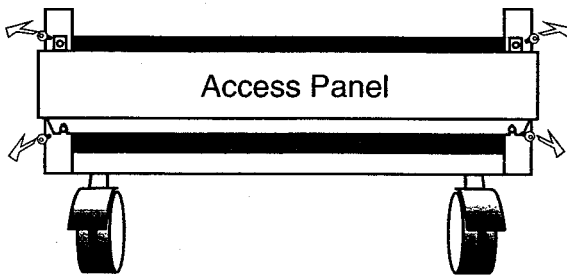
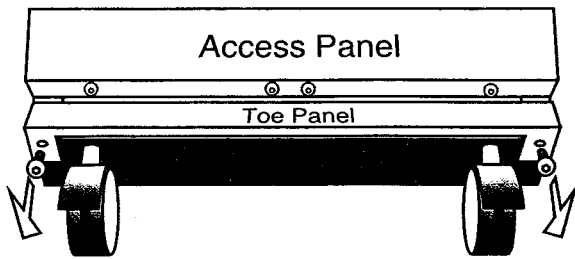

- Remove 4 screws securing front flange of cabinet to tub.

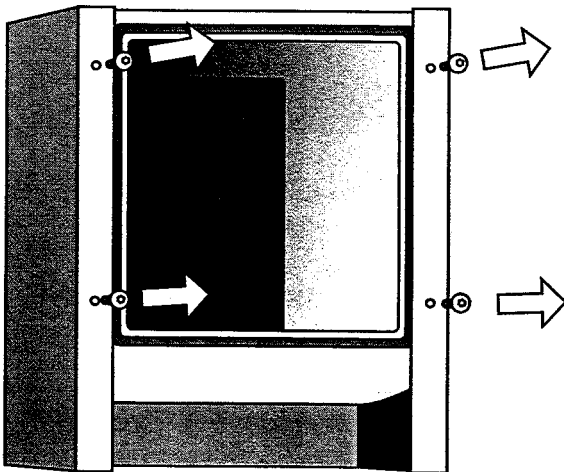

- Disconnect the power cord from the wire leads in the terminal box, the fill hose from the water valve and drain hose from the pump module.
- Remove wire tie securing drain and fill hoses to "U" shaped bracket.
- Carefully spread the front cabinet sides for clearance around the tub flange. **CAUTION: Do Not Bend excessively** as this will damage the metal cabinet at the rear corners.
- Pull the cabinet away from the dishwasher.
- Remove the 5 palnuts securing the retainer for the faucet coupler on the back of the cabinet.
- Cabinet removal is complete.

Casters

To Remove

1. Remove access and toe panels. (Refer to Access and Toe Panel removal as needed.)
2. Lift or block dishwasher up to access the casters.
3. With a screw driver pry caster from socket.

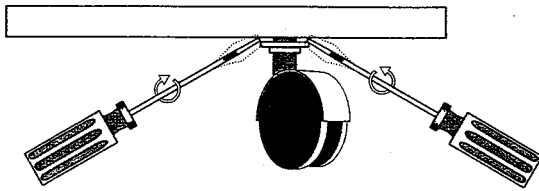

4. Cut plastic wire tie securing the hoses to hose support "U" bracket on rear wall of cabinet.

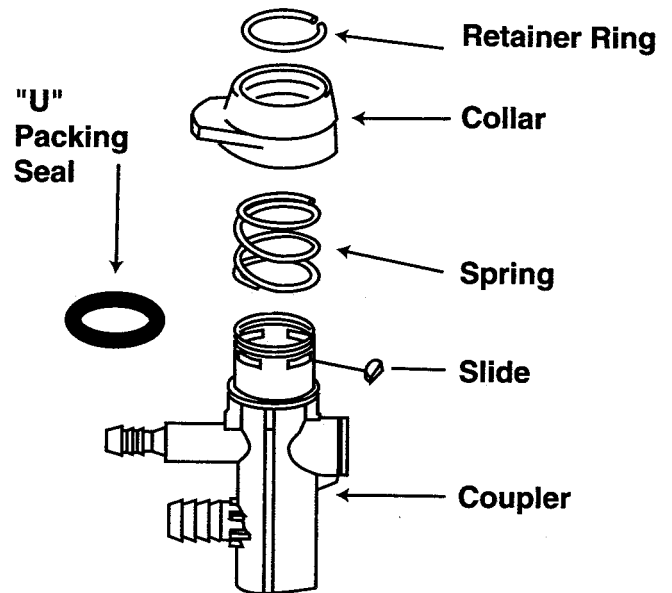

Faucet Coupler

The faucet coupler provides a means for filling and draining the portable dishwasher. It connects to a special adapter attached to the faucet at the sink. When not in use, the faucet coupler stores in the retainer on the back of the dishwasher.

To Remove

1. Remove access and toe panels. (See section on Access and Toe Panel removal.)
2. Remove fill hose from water valve and drain hose from the pump module.
3. Remove the wood top. (See section on Wood Top removal.)

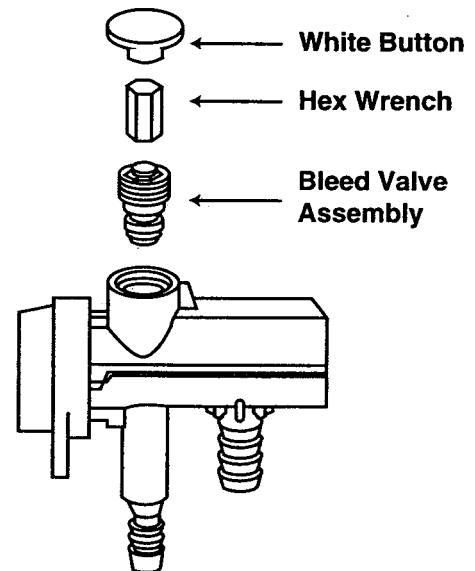

NOTE: A coupler repair kit is available to rebuild the coupler assembly. The kit contains a collar, spring, sliders, "U" packing washer, bleed valve and button. Contact your dealer or parts distributor for this kit.

Repair of the coupler can be done without removing the hose assembly from the dishwasher.

Retainer For Faucet Coupler

The retainer provides a storage area for the faucet coupler and power cord when the dishwasher is not in use.

To Remove

1. Remove cabinet. (See section on Cabinet removal.)
2. Remove the 5 palnuts securing the retainer to the rear cabinet wall.

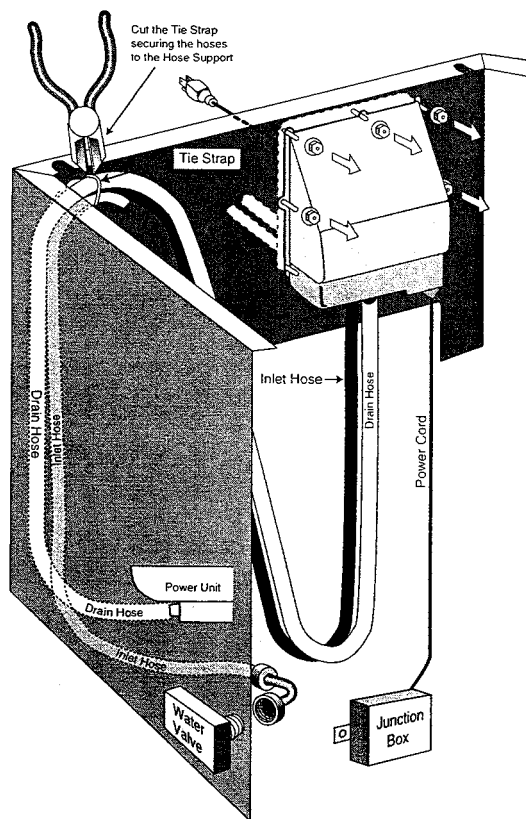

SECTION 4. GENERAL INFORMATION - (Sections A and B)

Information covered in this section includes:

SECTION A

Specifications

Warranty

Models - CDU20J, CDU8J, CDU5J, CDC5J, CDU2J

Cycles, Features and Options

Schematics

SPECIFICATIONS - SECTION A

BASIC DIMENSIONS	<u>Under Counter:</u> Height = 33-3/4" - 35-1/4" Width = 24" Depth = 22-3/4"
ELECTRICAL SUPPLY	115 Volts AC / 60 Hz All models require 20 amp fuse.
WATER SUPPLY	Water pressure should be 15-120 P.S.I. (1.06 - 8.44 kg/cm ²). Water temperature should be minimum of 120° F. when it enters the dishwasher.
DRAIN	1/2" I.D. flexible drain hose supplied with built-in models. High drain loop positioned on side of dishwasher. Must maintain minimum 32" height.
MOTOR AND PUMP	1/6 Horsepower motor, non-reversing pump with solenoid actuated drain valve.
WEIGHT (CRATED/UNCRATED)	Built-In Models - 100 lbs. (45 kg.)/ 85 lbs. (39 kg.)
CUSTOM PANEL DIMENSIONS	Door Panel Insert - 1/4" x 18-3/16" x 23-7/16" Access Panel Insert - 1/4" x 4-5/8" x 23-7/16"

WARRANTY

CROSLEY DISHWASHER WARRANTY

FULL ONE-YEAR WARRANTY

Any part which fails in normal home use during the first year after the date of original retail purchase will be repaired or replaced free of charge.

LIMITED WARRANTY

In the event a water leak develops in the DURA™-Tub or door liner in normal home use during the TWENTY-YEAR period starting from the date of original retail purchase, repair or replacement of the tub and/or door liner will be made FREE OF CHARGE, with the owner paying for travel charges beyond the servicer's normal service area after the first year.

On electronic touch models only—any microprocessor and touch pad assemblies which fail in normal home use during the second through fifth year from the date of original retail purchase, will be repaired or replaced free of charge for the part itself with the owner paying all other costs, including labor.

The FULL and LIMITED Warranties apply when the appliance is located in the United States. Appliances located elsewhere are covered by the limited warranty only, including parts that fail during the first year.

The specific warranties expressed above are the ONLY warranties provided by the manufacturer. This warranty gives you specific legal rights, and you may also have other rights that vary from state to state.

TO OBTAIN WARRANTY SERVICE

To locate an authorized service company in your area contact the Admiral dealer from whom your appliance was purchased; or call Maytag Customer Service. Should you not receive satisfactory warranty service, please contact:

Crosley Customer Assistance
c/o Maytag Customer Service
P.O. Box 2370
Cleveland, TN 37320-2370
1-800-688-1120

When contacting Maytag Customer Service be sure to provide the complete model and serial number of your appliance, the name and address of the dealer from whom you purchased the appliance and the date of purchase.

Should you still have a problem, write to Major Appliance Consumer Action Program, 20 North Wacker Drive, Chicago, Illinois 60606. MACAP is an industry sponsored but independent group of consumer experts who receive and act on complaints from appliance owners.

NOTE: When writing about an unsolved service problem, please include the following information:

- (a) Your name, address and telephone number;
- (b) Model number and serial number (found on the upper left corner of the tub opening) of your appliance;
- (c) Name and address of your dealer and the date the appliance was purchased;
- (d) A clear description of the problem you are having.
- (e) Water hardness, detergent brand and amount, water temperature, and cycle used.

MODELS

CDU20J

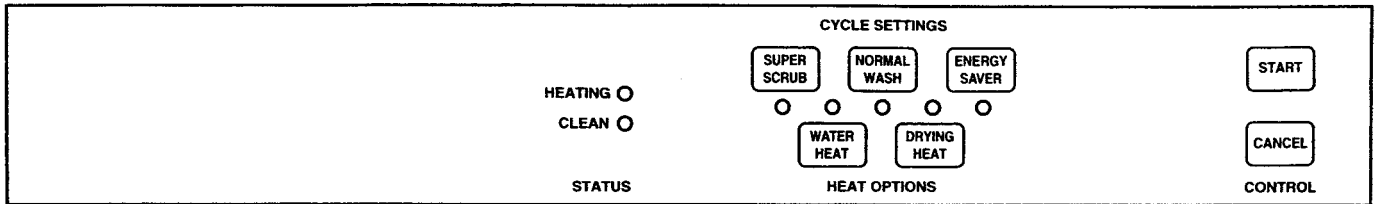

CDU8J

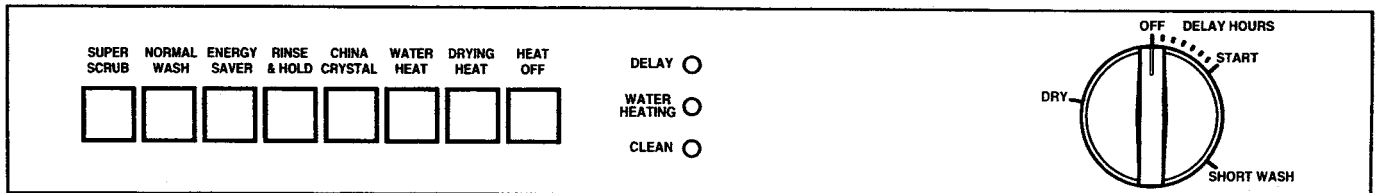

CDU5J / CDC5J

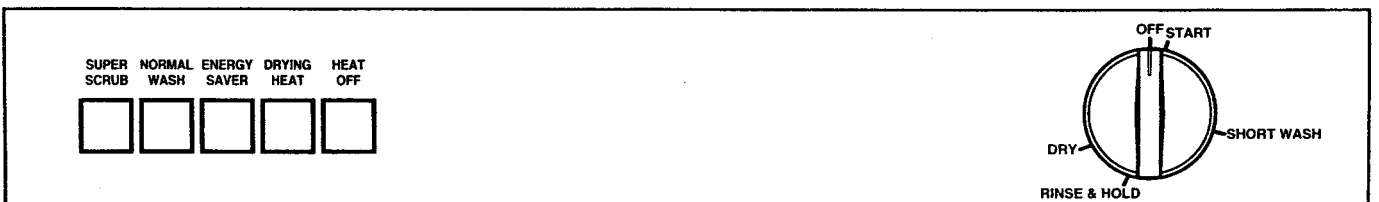

CDU2J

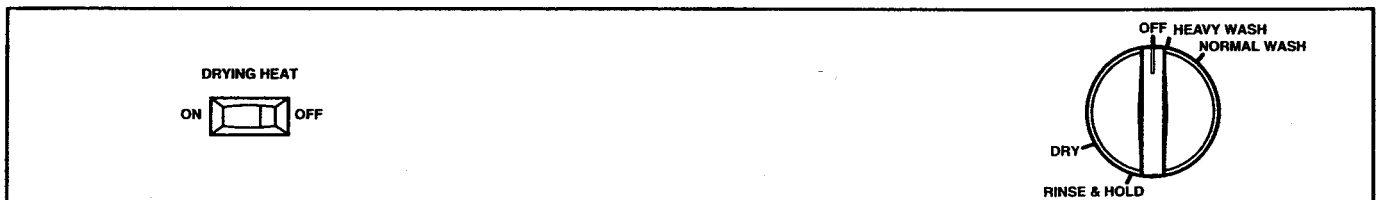

CYCLES and OPTIONS

CYCLE SETTING	AVAILABLE*	CYCLE SEQUENCE	APPROX. CYCLE TIME**	APPROX. WATER USAGE
Super Scrub	20J - 8J - 5J	Pre-Wash Rinse Rinse Main Wash Rinse Rinse Rinse Dry	66 minutes	10.5 Gal. 39.8 Liters
Heavy Wash	2J	Pre-Wash Rinse Rinse Rinse Main Wash Rinse Rinse Dry	66 minutes	10.5 Gal. 39.8 Liters
Normal Wash	20J - 8J - 5J - 2J	Pre-Wash Rinse Rinse Main Wash Rinse Rinse Dry	56 minutes	9 Gal. 34 Liters
Energy Saver	8J - 5J	Pre-Wash Rinse Main Wash Rinse Rinse Dry	56 minutes	7.5 Gal. 28.4 Liters
China / Crystal	8J	Pre-Wash Rinse Main Wash Rinse Rinse Dry	56 minutes	5.3 Gal. 20 Liters
Short Wash	8J - 5J	Main Wash Rinse Rinse Dry	36 minutes	4.5 Gal. 17 Liters
Rinse & Hold	8J - 5J - 2J	Rinse Rinse	13 minutes	3 Gal. 11.4 Liters

*Portable Model, CDC5J, has same features as CDU5J.

**Drying Heat available on all cycles except Rinse & Hold. Add 30 minutes to cycle times listed above.

OPTIONS

WATER HEAT

MODELS CDU20J and CDU8J Selection of Water Heat option ensures that water is heated to the proper temperature for best results.

CDU8J feature thermostatically-controlled water heating. **CDU20J** models heating indicator light will glow whenever the heater is on. On the **CDU8J** model the water heating indicator light will glow whenever the heater is on.

DRYING HEAT

This option activates the heating element located in the bottom of the tub. The heat generated, along with convection, dries the dishes. Heated air flows naturally among the dishes, absorbing moisture that is exhausted out the front of the dishwasher. Available on all cycles except Rinse & Hold. Add 30 minutes to cycle times listed.

HEAT OFF

CDU8J, CDU5J and CDC5J This option uses natural convection for energy efficient drying. Residual heat from the dishes evaporates moisture and it is exhausted out the front of the dishwasher.

DELAY HOURS

Model CDU8J only. This option will delay any cycle for up to 6 hours. The dishwasher automatically starts when the delay expires.

CANCEL

Electronic Touch Pads only. Cancels the cycle. If option is activated during a Wash or Rinse cycle, it drains first. If pad is pressed again during draining, unit will shut off.

START

Electronic Touch Pads only. Pressing this pad immediately activates cycle selections(s) or cancels Delay.

STATUS LIGHTS

CDU20J and CDU8J feature indicator lights including "Delay", "Heating" or "Water Heating" and "Clean" The "Clean" indicator light stays on until the dishwasher is opened, on the **CDU20J**. On the **CDU8J**, the "Clean" indicator light goes off when the user turns the dial to the "Off" position.

SCHEMATICS

CDU20J Single Wax Motor and Capacitors

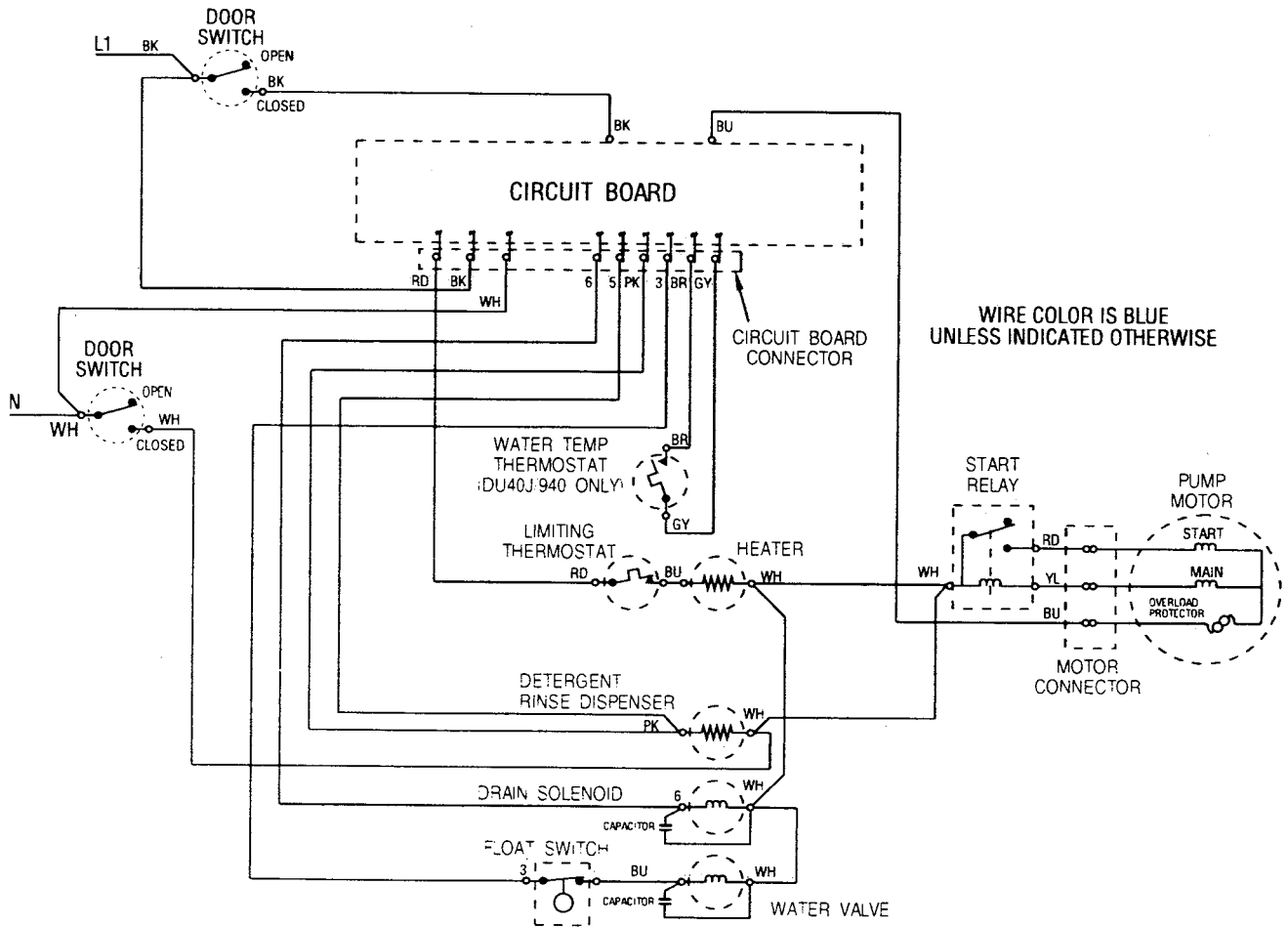

CDU20J

Dual Wax Motors and Capacitors

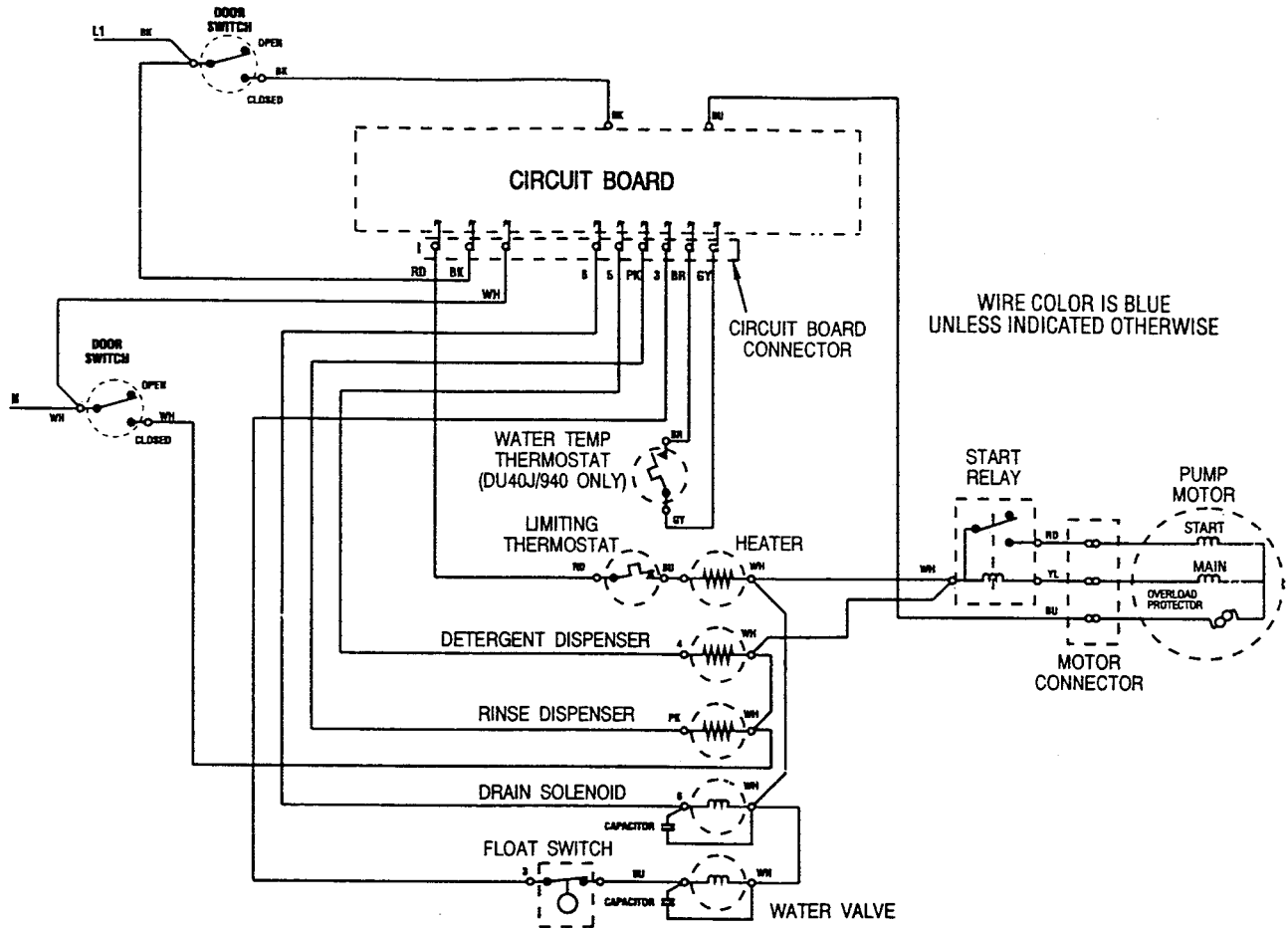

CDU20J Dual Wax Motors

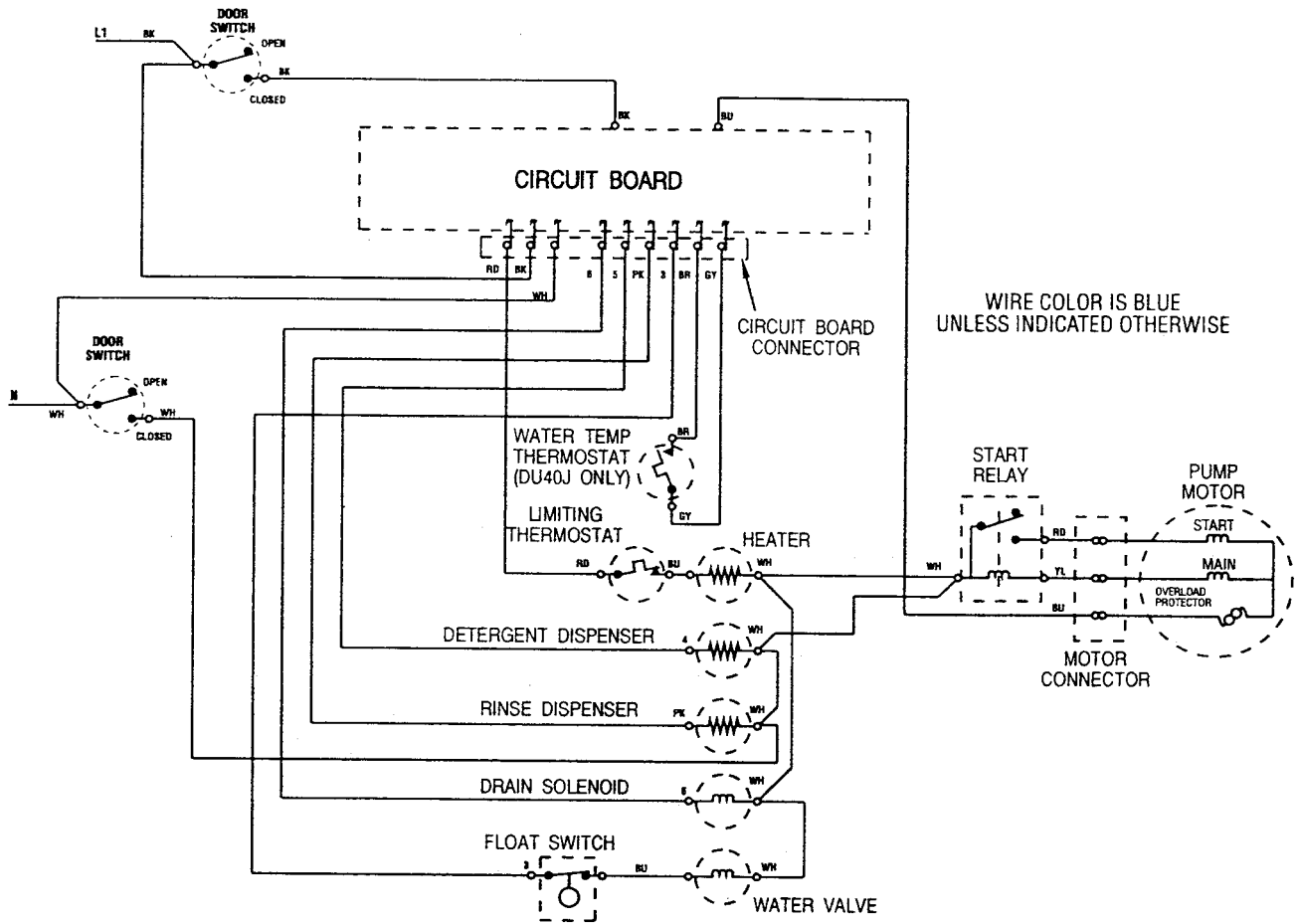

CDU8J

Single Wax Motor

TIMER INFORMATION			TIME CHART - 90 SECONDS PER INCREMENT												
CAM NO.	CIRCUIT	FUNCTION	5	10	15	20	25	30	35	40	45	50	55	60	65
0	T	CYCLE EXTENDER (SS)													
	B	EXTRA FILL (NW)													
2	T	TIMER MOTOR													
	B	CLEAN LAMP													
4	T	HEAT DRY													
	B	MOTOR													
6	T	ENERGY SAVER													
	B														
8	T	DRAIN SOLENOID													
	B	WATER VALVE													
10	T	DELAY LAMP													
	B	CHINA CRYSTAL *													
1	T	RINSE & HOLD													
	B	ALL OTHER													
3	T	DETERGENT DISPENSER													
	B	RINSE AID DISPENSER													
5	T	CYCLE EXTENDER													
	B	HEAT - WASH													
7	T	THERMOSTAT BYPASS													
	B														
%		DETENT													

CONTACTS OPEN 1-8 SECONDS	CONTACTS OPEN 1-7 SECONDS	CONTACTS CLOSED 1-7 SECONDS	CONTACTS CLOSED
S - FILL 86±3 SECONDS	F - FILL 90±3 SECONDS		
* CLOSURES OF JOB TO BE 63±2 SECONDS			

- THIS DRAIN AND FILL WILL NOT OCCUR IF ENERGY SAVER IS SELECTED.
- CYCLE WILL BE EXTENDED APPROXIMATELY 10 MINUTES HERE IF SUPER SCRUB IS SELECTED.
- THIS DRAIN AND FILL WILL ONLY OCCUR IF SUPER SCRUB IS SELECTED.

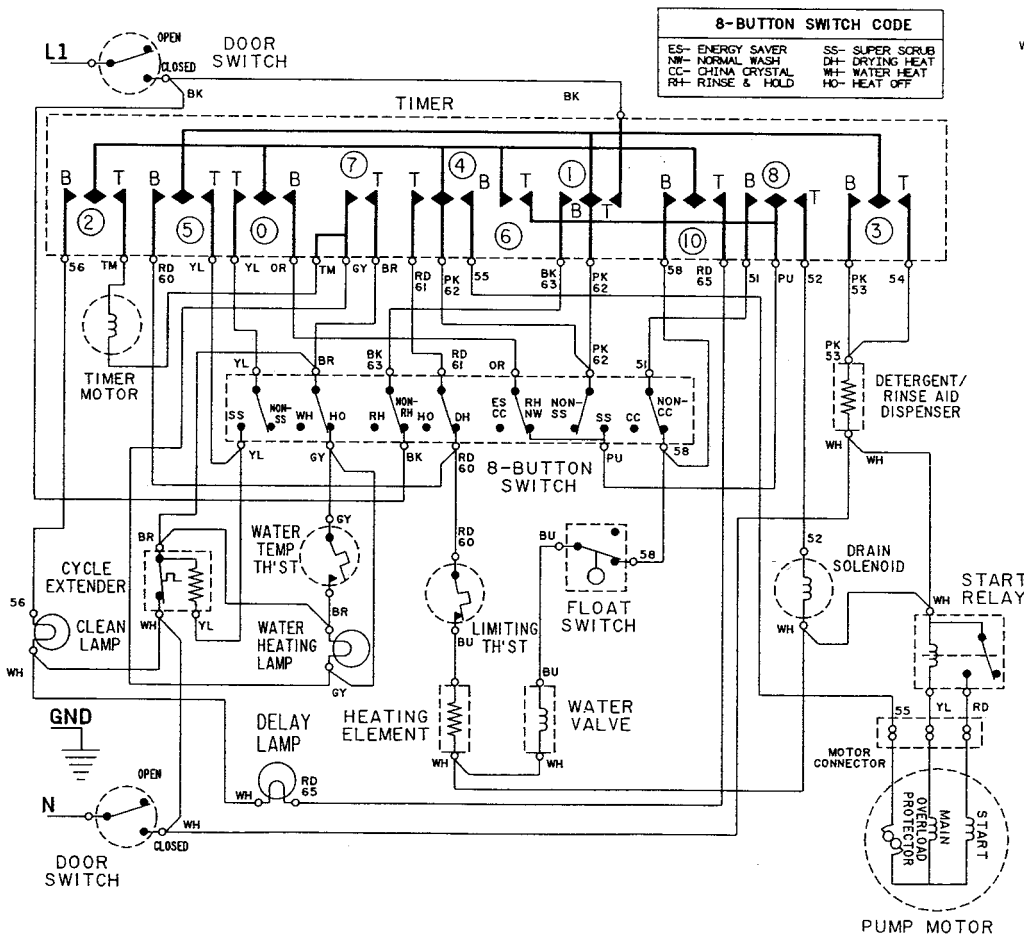

8-BUTTON SWITCH CODE			
ES-	ENERGY SAVER	SS-	SUPER SCRUB
NW-	NORMAL WASH	DH-	DRYING HEAT
CC-	CHINA CRYSTAL	WH-	WATER HEAT
RH-	RINSE & HOLD	HO-	HEAT OFF

WHITE TIMER CONNECTOR (WIRE INSERTION SIDE)

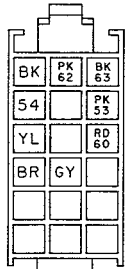

WIRE COLOR IS BLUE UNLESS OTHERWISE SPECIFIED.

BLACK TIMER CONNECTOR (WIRE INSERTION SIDE)

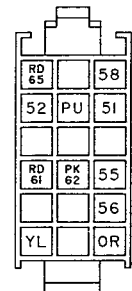

CDU8J Dual Wax Motors

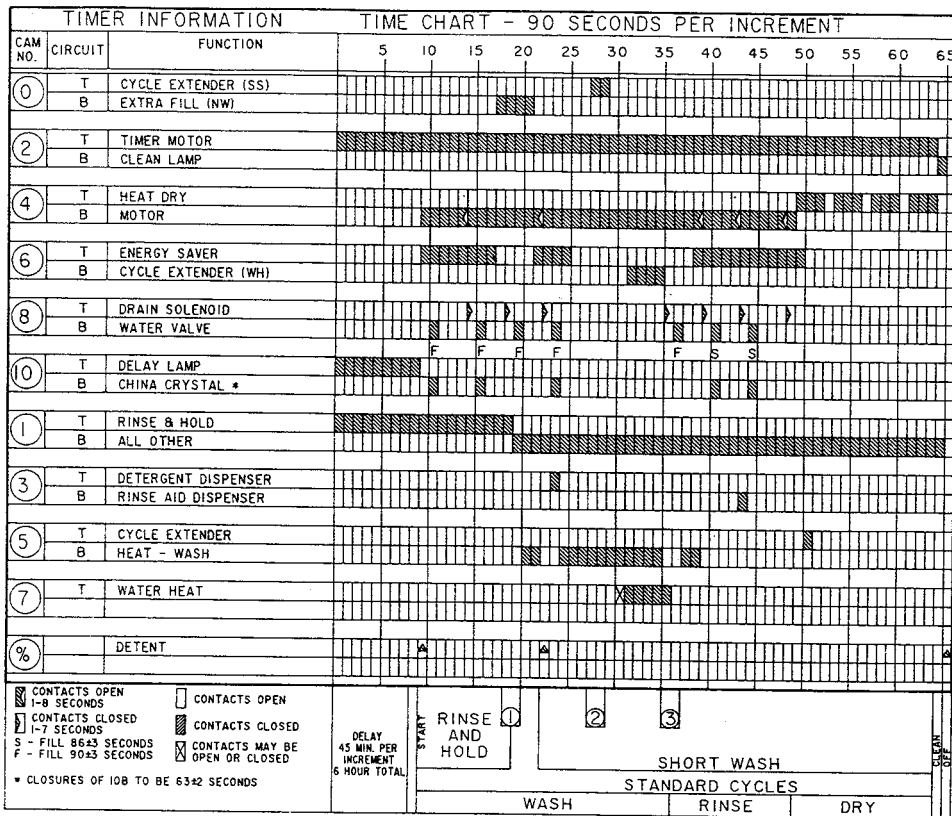

- THIS DRAIN AND FILL WILL NOT OCCUR IF ENERGY SAVER IS SELECTED.
- CYCLE WILL BE EXTENDED APPROXIMATELY 10 MINUTES HERE IF SUPER SCRUB IS SELECTED.
- THIS DRAIN AND FILL WILL ONLY OCCUR IF SUPER SCRUB IS SELECTED.

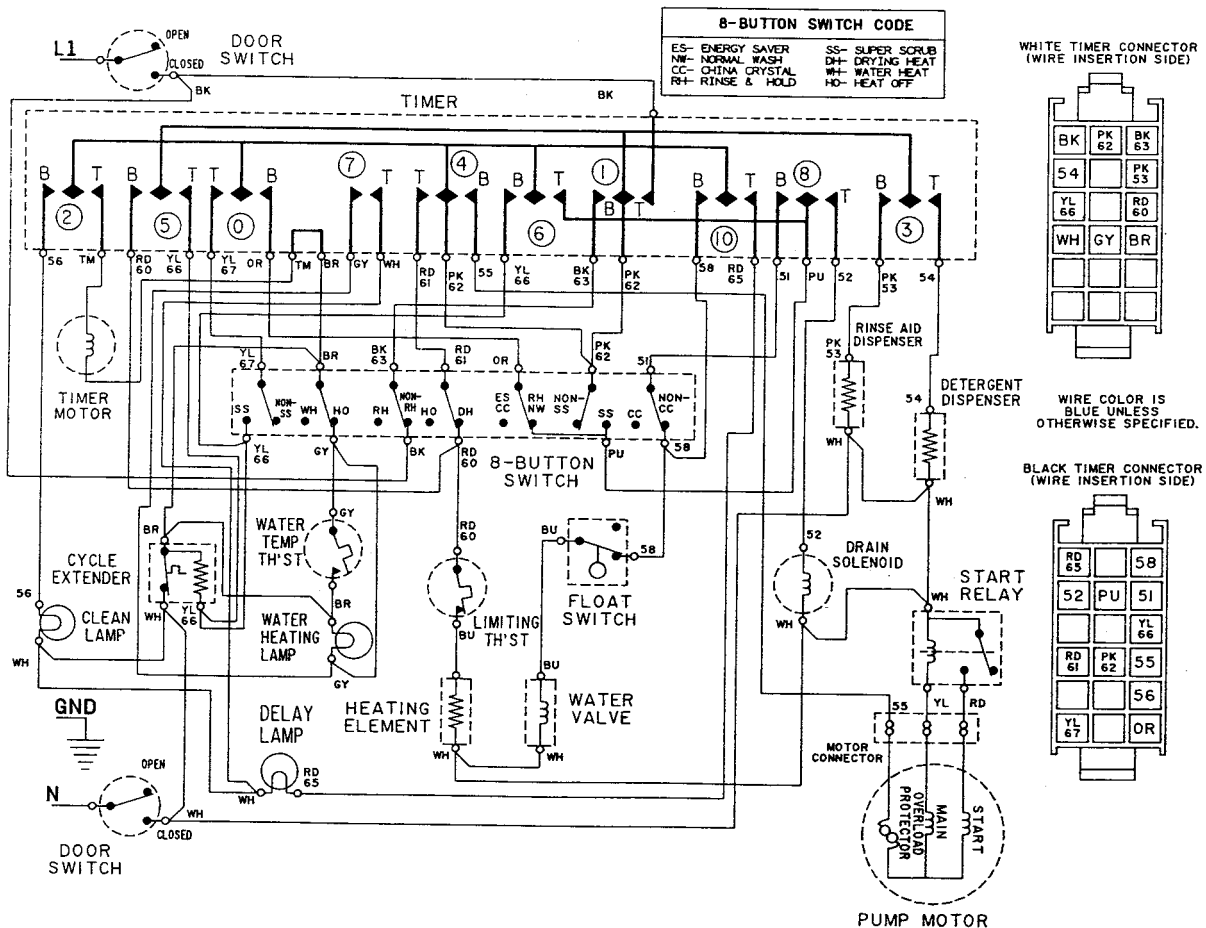

CDU5J & CDC5J

Single Wax Motor

TIMER INFORMATION			TIME CHART - 90 SECONDS PER INCREMENT											
CAM NO.	CIRCUIT	FUNCTION	5	10	15	20	25	30	35	40	45	50	55	60
0	T	CYCLE EXTENDER												
	B	EXTRA FILL (NW)												
2	T	DETERGENT DISPENSER												
	B	RINSE AID DISPENSER												
4	T	TIMER MOTOR												
	-	-												
6	T	HEAT-DRY												
	B	MOTOR												
8	T	ENERGY SAVER												
	B	HEAT-WASH												
10	T	DRAIN SOLENOID												
	B	WATER VALVE												

CONTACTS OPEN 1-8 SECONDS	CONTACTS OPEN 1-7 SECONDS
CONTACTS CLOSED 1-7 SECONDS	CONTACTS CLOSED

S - FILL 86±3 SECONDS
 F - FILL 90±3 SECONDS
 W - FILL 87 ±5-2 SECONDS

- ① THIS DRAIN AND FILL WILL NOT OCCUR IF ENERGY SAVER IS SELECTED.
- ② CYCLE EXTENDER WILL ADD APPROXIMATELY 10 MINUTES HERE ONLY IF SUPER SCRUB IS SELECTED.
- ③ THIS DRAIN AND FILL WILL OCCUR ONLY IF SUPER SCRUB IS SELECTED.

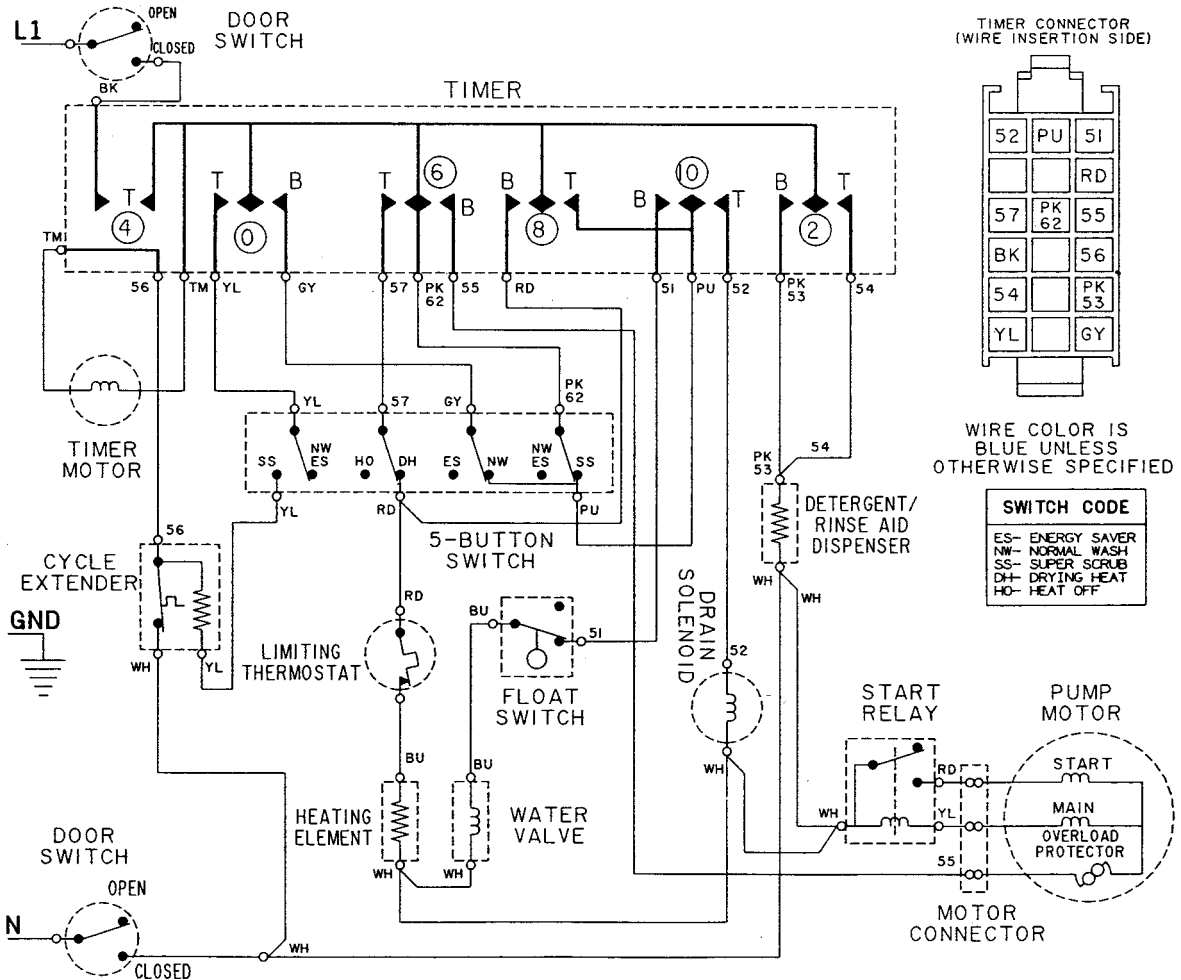

CDU5J & CDC5J Dual Wax Motors

TIMER INFORMATION			TIME CHART - 90 SECONDS PER INCREMENT											
CAM NO.	CIRCUIT	FUNCTION	5	10	15	20	25	30	35	40	45	50	55	60
0	T	CYCLE EXTENDER												
	B	EXTRA FILL (NW)												
2	T	DETERGENT DISPENSER												
	B	RINSE AID DISPENSER												
4	T	TIMER MOTOR												
	-	-												
6	T	HEAT-DRY												
	B	MOTOR												
8	T	ENERGY SAVER												
	B	HEAT-WASH												
10	T	DRAIN SOLENOID												
	B	WATER VALVE												

[Hatched] CONTACTS OPEN 1-8 SECONDS [White] CONTACTS OPEN 1-7 SECONDS [Dotted] CONTACTS CLOSED 1-7 SECONDS [Solid] CONTACTS CLOSED 1-8 SECONDS	[White] CONTACTS OPEN [Hatched] CONTACTS CLOSED	S - FILL 86±3 SECONDS F - FILL 90±3 SECONDS W - FILL 87.45±2 SECONDS
---	--	--

OFF	START	1	2	3	RINSE AND HOLD									
					SHORT WASH									
					STANDARD CYCLES									
					WASH			RINSE			DRY			

- ① THIS DRAIN AND FILL WILL NOT OCCUR IF ENERGY SAVER IS SELECTED.
- ② CYCLE EXTENDER WILL ADD APPROXIMATELY 10 MINUTES HERE ONLY IF SUPER SCRUB IS SELECTED.
- ③ THIS DRAIN AND FILL WILL OCCUR ONLY IF SUPER SCRUB IS SELECTED.

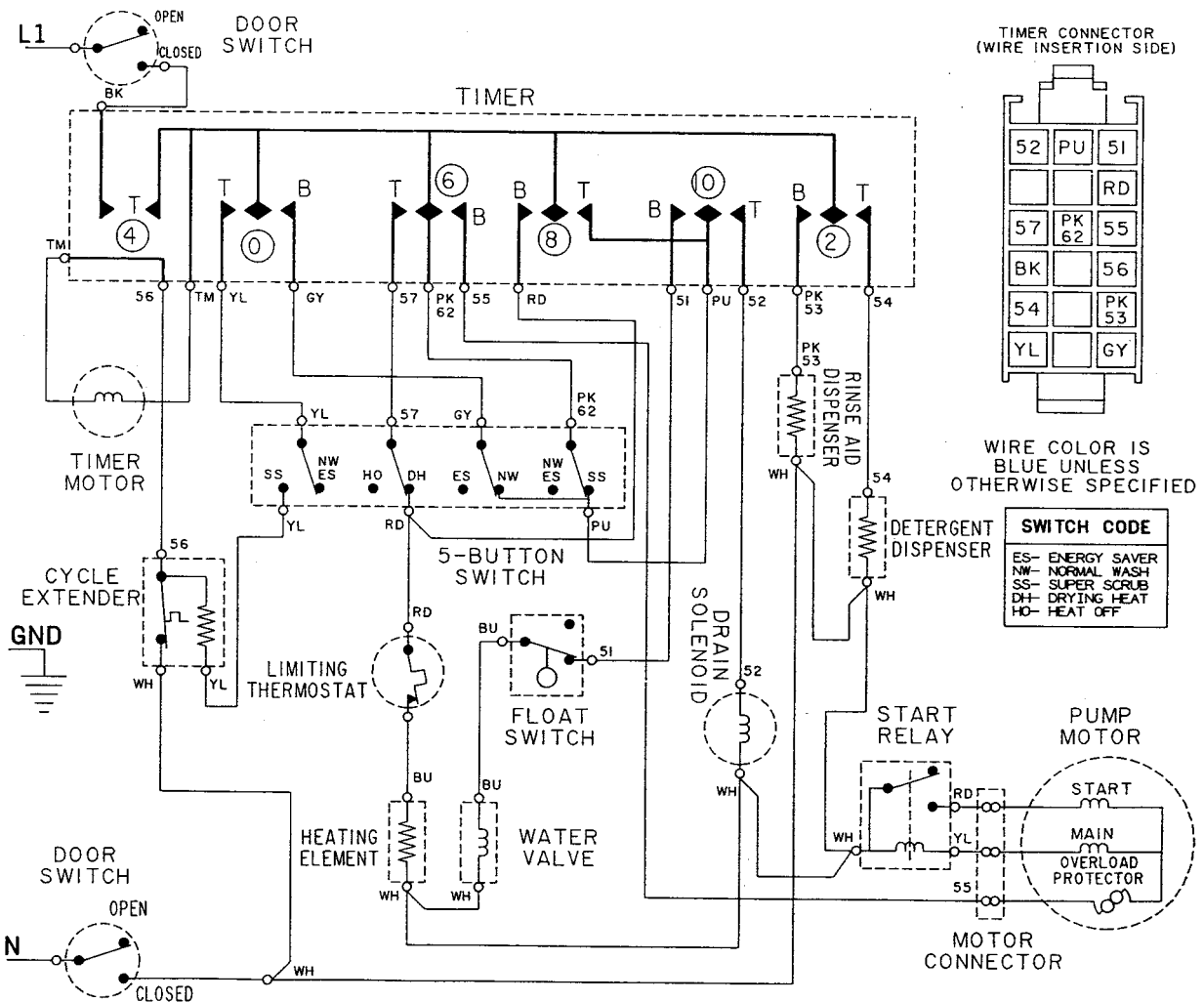

CDU2J

TIMER INFORMATION			TIME CHART - 90 SECONDS PER INCREMENT												
CAM NO.	CIRCUIT	FUNCTION	5	10	15	20	25	30	35	40	45	50	55	60	65
2	T	DETERGENT DISPENSER	[Timing chart showing detergent dispenser pulses]												
	B	RINSE AID DISPENSER	[Timing chart showing rinse aid dispenser pulses]												
4	T	TIMER MOTOR	[Timing chart showing timer motor activity]												
	-														
6	T	HEAT-DRY	[Timing chart showing heat-dry pulses]												
	B	MOTOR	[Timing chart showing motor pulses]												
8	-														
	B	HEAT-WASH	[Timing chart showing heat-wash pulses]												
10	T	DRAIN	[Timing chart showing drain pulses]												
	B	WATER VALVE	[Timing chart showing water valve pulses]												

<ul style="list-style-type: none"> [Symbol] CONTACTS OPEN 1-8 SECONDS [Symbol] CONTACTS CLOSED 1-7 SECONDS 	<ul style="list-style-type: none"> [Symbol] CONTACTS OPEN [Symbol] CONTACTS CLOSED S - FILL 86±3 SECONDS F - FILL 90±3 SECONDS W - FILL 87 ±5-2 SECONDS
--	--

PRE-WASH	PRE-WASH	MAIN WASH	RINSE	DRY
NORMAL WASH			RINSE AND HOLD	
HEAVY WASH				

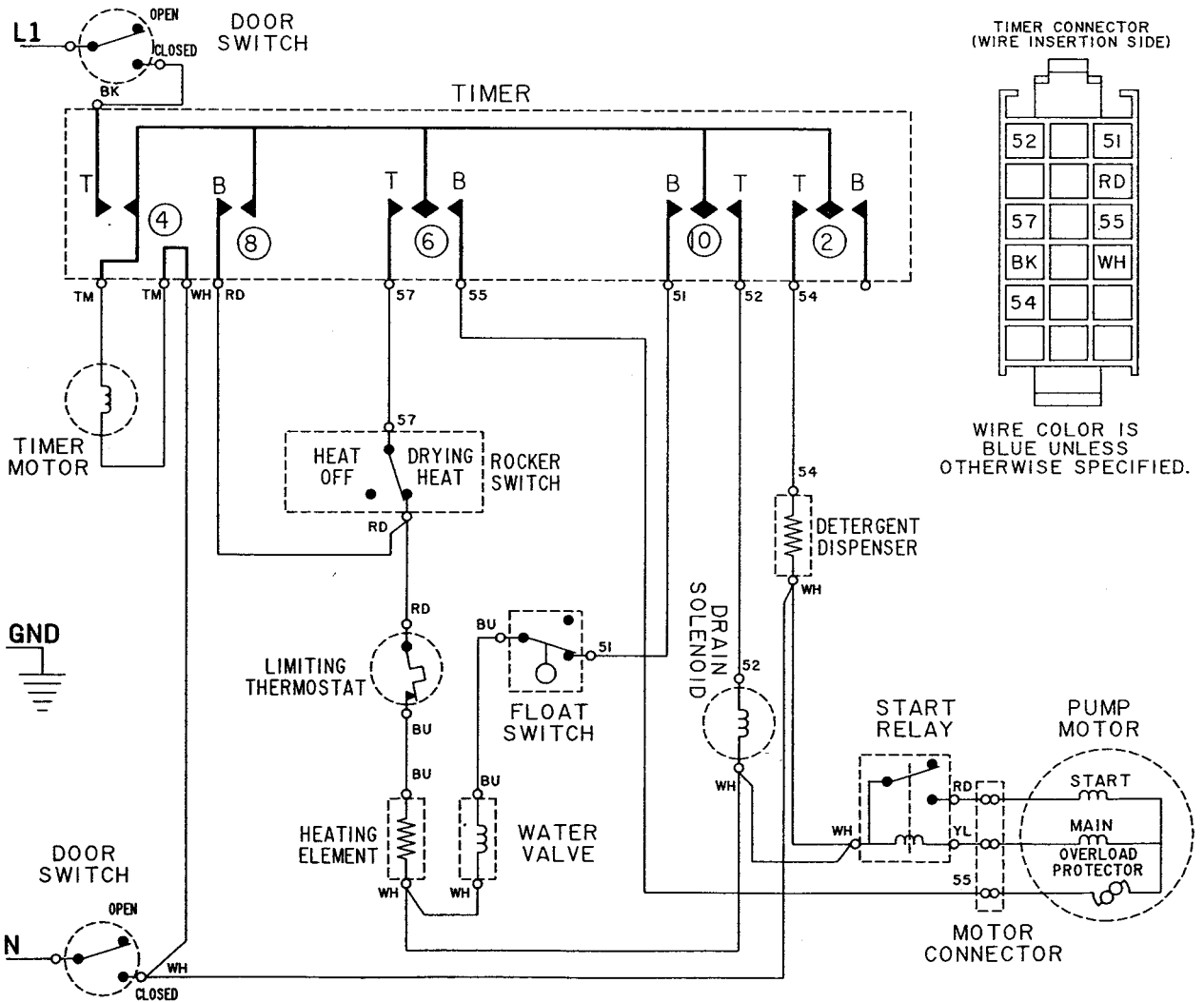



SPECIFICATIONS - SECTION B

SECTION B

Specifications

*Warranty - (For Warranty information refer to page 4-2.)

Models - CDU250, CDU400, CDC400, CDU450, CDU600

Cycles, Features and Options

Schematics

BASIC DIMENSIONS	<p><u>Under Counter:</u> Height = 34" - 35" (86-89 cm) Width = 23-7/8" (61 cm) Depth = 22-3/4" (57.8 cm)</p>
ELECTRICAL SUPPLY	<p>120 Volts AC / 60Hz All models require 15 amp fuse.</p>
WATER SUPPLY	<p>Water pressure should be 15-120 P.S.I. (1.06 - 8.44 kg/cm²). Water temperature should be minimum of 120° -140° F. when it enters the dishwasher.</p>
DRAIN	<p>80" Flexible multi-size (5/8", 3/4", 1") I.D. drain hose supplied with built-in models. High drain loop positioned on side of dishwasher. Must maintain minimum 32" height.</p>
MOTOR AND PUMP	<p>1/6 Horsepower motor, high-torque split-phase induction motor with high efficiency non-reversing pump with solenoid actuated drain valve.</p>
WEIGHT (CRATED/UNCRATED)	<p>Built-In Models - 100 lbs. (45 kg.)/ 85 lbs. (39 kg.)</p>
CUSTOM PANEL DIMENSIONS	<p>Decorative Door Panel Insert - 1/4" x 18-3/16" x 23-9/16" (.64 cm x 46.2 cm x 59.8 cm) Decorative Access Panel Insert - 1/4" x 4-5/8" x 23-11/16" (.64 cm x 11.7 cm x 60.2 cm) NOTE: Installing a custom access panel requires accessory kit #DAX1000AAX available from nearest Crosley dealer.</p>

MODELS - CONTROL PANELS

Crosley CDU250 Dishwasher

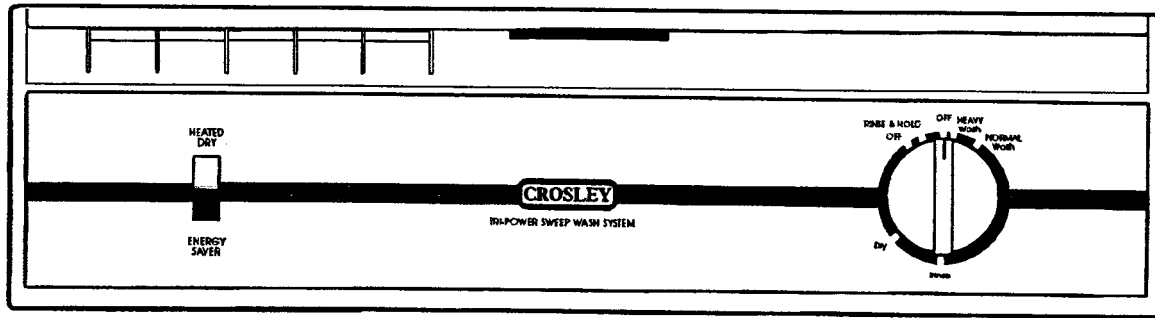

Crosley CDU400 Dishwasher

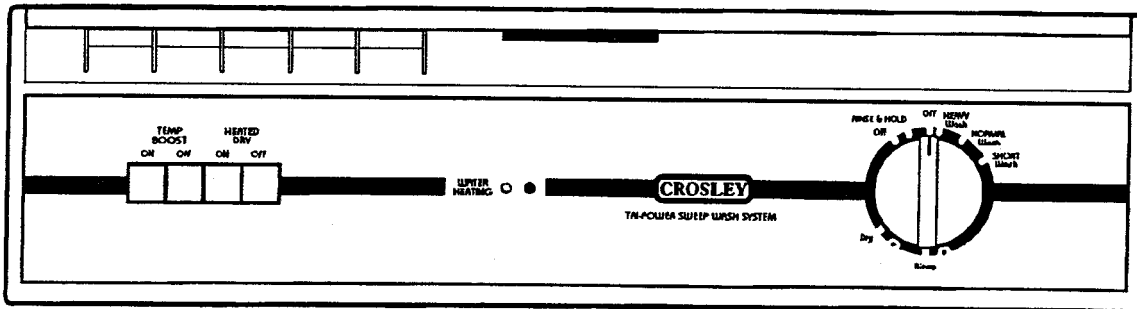

Crosley CDU450 Dishwasher

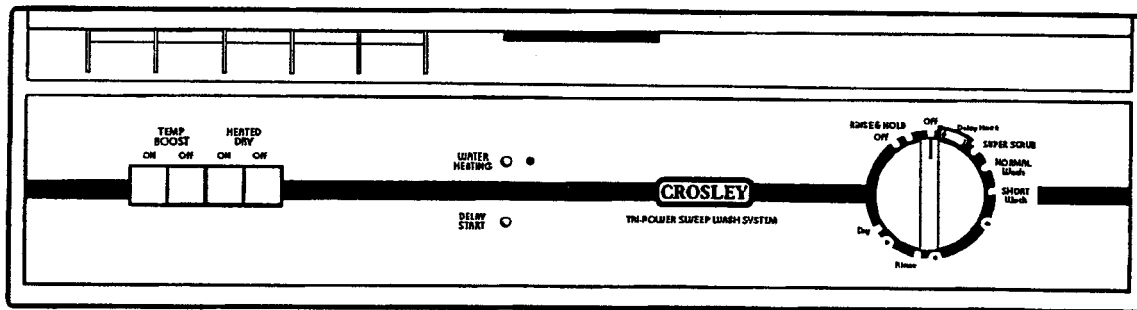

Crosley CDU600 Dishwasher

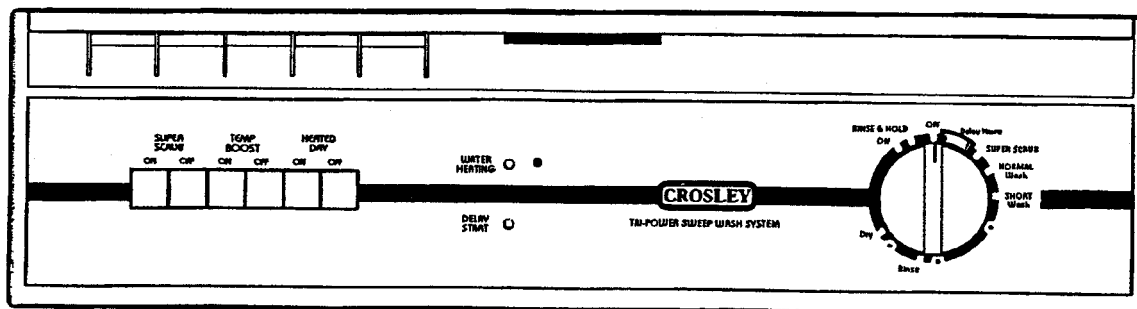

FEATURES, CYCLES, CONTROLS

FEATURES:

CONTROLS	CDU250	CDU400	CDC400	CDU450	CDC450	CDU600
Push Buttons	Rocker	4	4	4	4	6
Heat Delay w/Lite	No	Yes	Yes	Yes	Yes	Yes
Delay Start w/Lite	No	No	No	Yes	Yes	Yes
Rinse-Aid Dispenser	No	Yes	Yes	Yes	Yes	Yes
Wash Levels	3	3	3	3	3	3
5 Point Filter System	3 Pt.	3 Pt.	3 Pt.	3 Pt.	3 Pt.	5 Pt.
Insulation	Std.	Std.	Std.	Std.	Std.	Std.
Silverware Basket Handle	No	Yes	Yes	Yes	Yes	Yes

CYCLES:

OPTIONS	CDU250	CDU400	CDC400	CDU450	CDC450	CDU600
Temp Boost	No	Yes	Yes	Yes	Yes	Yes
Super Scrub	No	Yes	Yes	Yes	Yes	Yes
Heated Dry On/Off	No	Yes	Yes	Yes	Yes	Yes
Heated Dry/ Energy Saver	Yes	No	No	No	No	No

CYCLES:

MODELS	CDU250	CDU400	CDC400	CDU450	CDC450	CDU600
Rinse & Hold	Yes	Yes	Yes	Yes	Yes	Yes
Short Cycle	No	Yes	Yes	Yes	Yes	Yes
Normal Cycle	Yes	Yes	Yes	Yes	Yes	Yes
Super Scrub	No	No	No	No	No	Yes
Pots & Pans/ Heavy	Yes	Yes	Yes	Yes	Yes	No

CYCLE	CYCLE SEQUENCE	CYCLE TIME	WATER USAGE
Rinse & Hold	Rinse	6 Minutes	1.5 Gal. (6 Liters)
Short Cycle	Pre-Wash, Rinse, Main Wash [2] & 2 Rinses [3]	57 Minutes 92 Minutes [1]	7.5 Gal. (26 Liters)
Normal Cycle	Pre-Wash, 2 Rinses, Main Wash [2] & 2 Rinses [3]	65 Minutes 100 Minutes [1]	9 Gal. (34 Liters)
Pots & Pans Heavy Super Scrub	4 Pre-Washes [4] [5] Extended Main Wash [4] [5] & 2 Rinses [4] [5]	72 Minutes 106 Minutes [1]	10.5 Gal (42 Liters)

[1] With Heat Dry option

[2] Indicates Temp Boost water heating option

[3] Indicates final Rinse has Temp Boost water heating option

[4] Indicates Temp Boost water heating is automatic in the final pre-wash, main wash and last rinse.

[5] When Super Wash option is On, the Temp Boost checks all pre-wash, main wash and rinse.

CYCLE DEFINITIONS

Rinse & Hold

Rinses the dishes being held for a full load. Minimizes any food odor from building up in the dishwasher. The dishwasher will fill with water to the proper level, wash for one minute and 40 seconds, then drain and turn off.

Delay Start

Allows the user to start the wash cycle at a more convenient or energy efficient time. On mechanical timer models, set the selector knob to the desired number of delay hours, select the wash option and latch the dishwasher door. An indicator will light in the center of the control panel to let the user know it is in a delay mode.

Short Cycle

Designed for lightly soiled loads.

Normal Cycle

Designed for loads containing normally soiled dishes.

Pots & Pans/Heavy/Super Scrub

Provides a longer cycle for items with heavy or baked-on food soils.

HEATING OPTIONS

Heated Dry

The heating element pulsates **On** for 5 minutes, and **Off** for 1 minute and 40 seconds periodically throughout the **Dry** cycle.

Automatic Water Heating

Established in some of the **Pre-wash** and **Rinse** periods and the entire main wash of the **Super Scrub** and **Pots & Pans/Heavy** cycles. Also, found in the final **Pre-rinse**, **main wash** and **final rinse** of the **Short** and **Normal** cycles. The temperature of the water is raised approximately 1° F. per minute. This is preset and automatically raises the water temperature to enhance washing performance.

Temp Boost

Checks and raises the water temperature, if necessary, to approximately 135° F. to 140° F., during the end of the main wash period and the middle of the final rinse periods. This option ensures detergents will activate and the fats in the food soil will break down. It is recommended for home owners with low hot water temperature.

Super Scrub

Checks and raises the water temperature, if necessary, to approximately 135° F. to 140° F., during the middle of the final pre-wash, final rinse and at the end of the main wash periods. This option ensures detergents will activate and the fats in the food soil will break down on heavily soiled items. It provides the optimum washing performance because the water temperature is checked and raised, if necessary, in the prewash, prior to the main wash. This option can be used on any of the selected cycles.

Super Wash

Adds automatic water heating (1° F. per minute) to all pre-wash and rinse periods of the selected cycle. The water temperature is checked and raised, if necessary, to approximately 135° F. to 140° F., during the beginning of the main wash period and the middle of the final rinse period. This option ensures detergents will activate, fats will break down and increases the water temperature throughout all periods of the cycle. It provides the maximum washing performance because the water temperature is checked and raised, if necessary, in the beginning to the main wash. This option maximizes cleaning and drying performance for all selected cycles.

WIRING DIAGRAMS AND SCHEMATICS

An electrical schematic is packed in every unit. It is located inside the console.
Always remember to return the schematic to its original location for future reference.

MODELS
CDU250
CDU400
CDU450
CDU600

WIRING DIAGRAM AND SCHEMATIC FOR CDU250

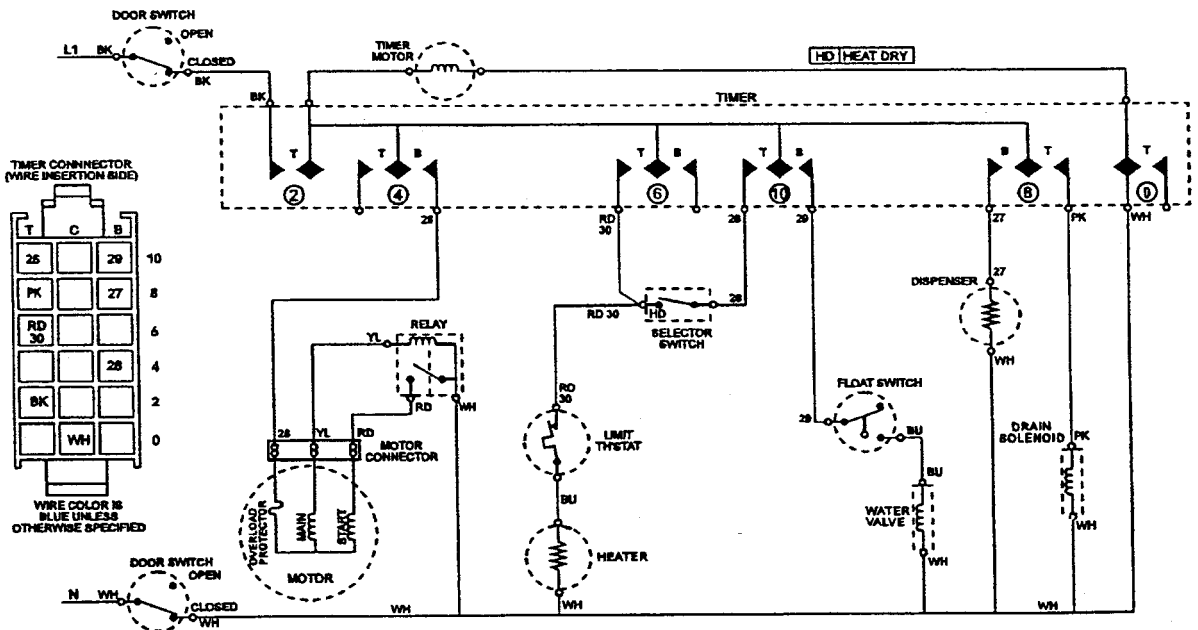
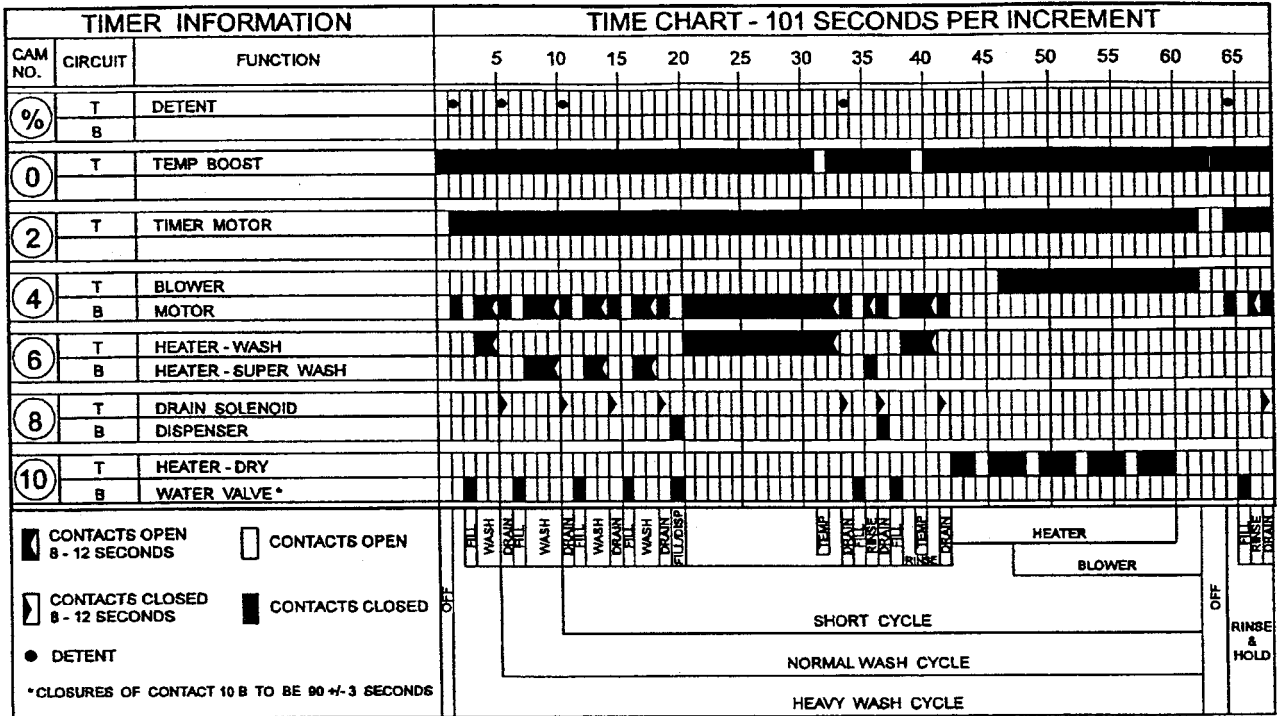

CAUTION

Except as necessary to perform a particular step in servicing a product, the electrical power supply should **ALWAYS** be disconnected when servicing a product.

WIRING DIAGRAM AND SCHEMATIC FOR CDU400/CDC400

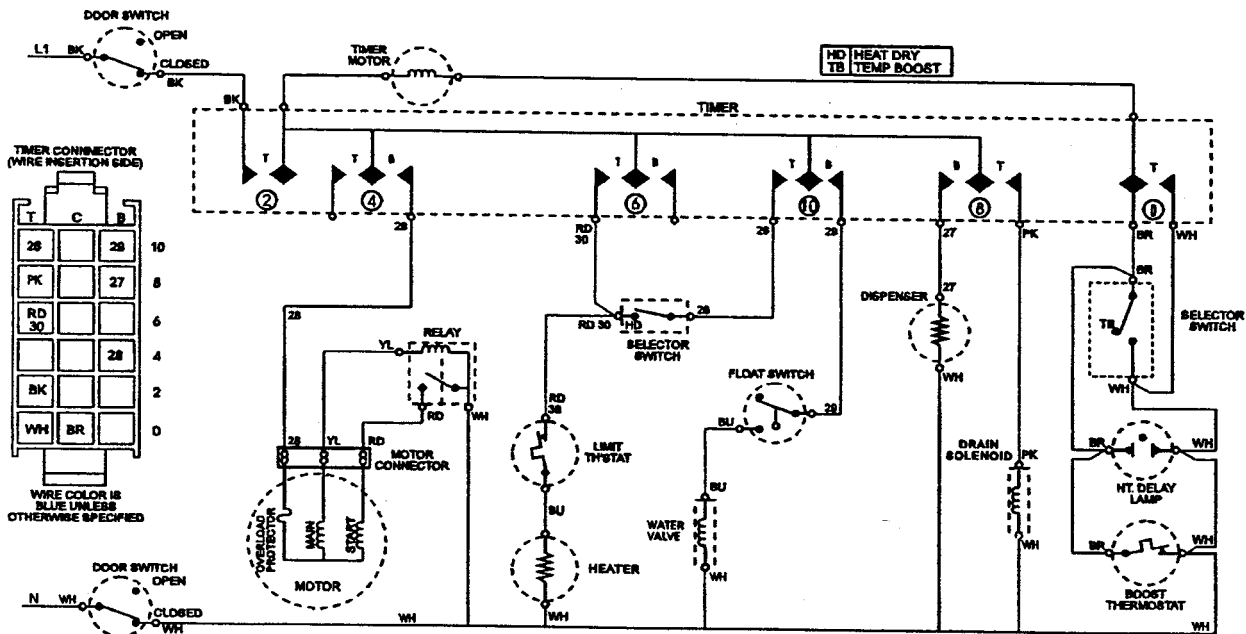
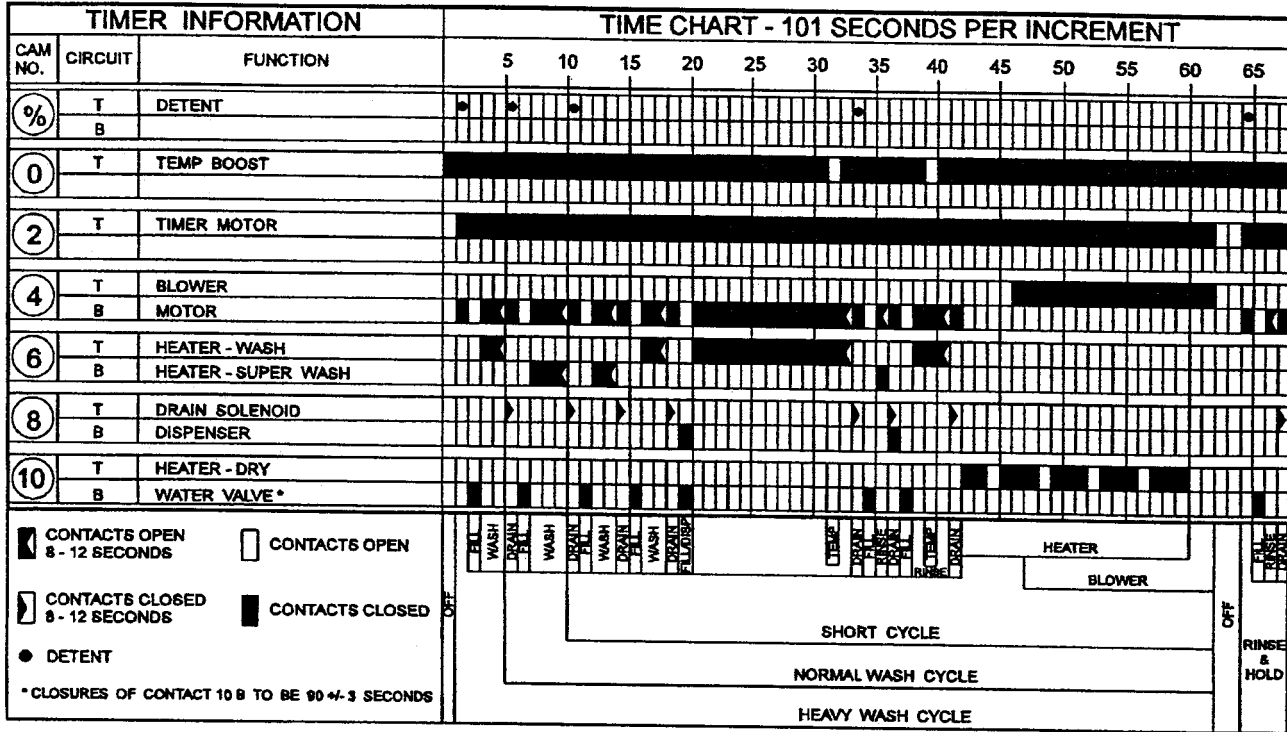

CAUTION

Except as necessary to perform a particular step in servicing a product, the electrical power supply should **ALWAYS** be disconnected when servicing a product.

WIRING DIAGRAM AND SCHEMATIC FOR CDU450

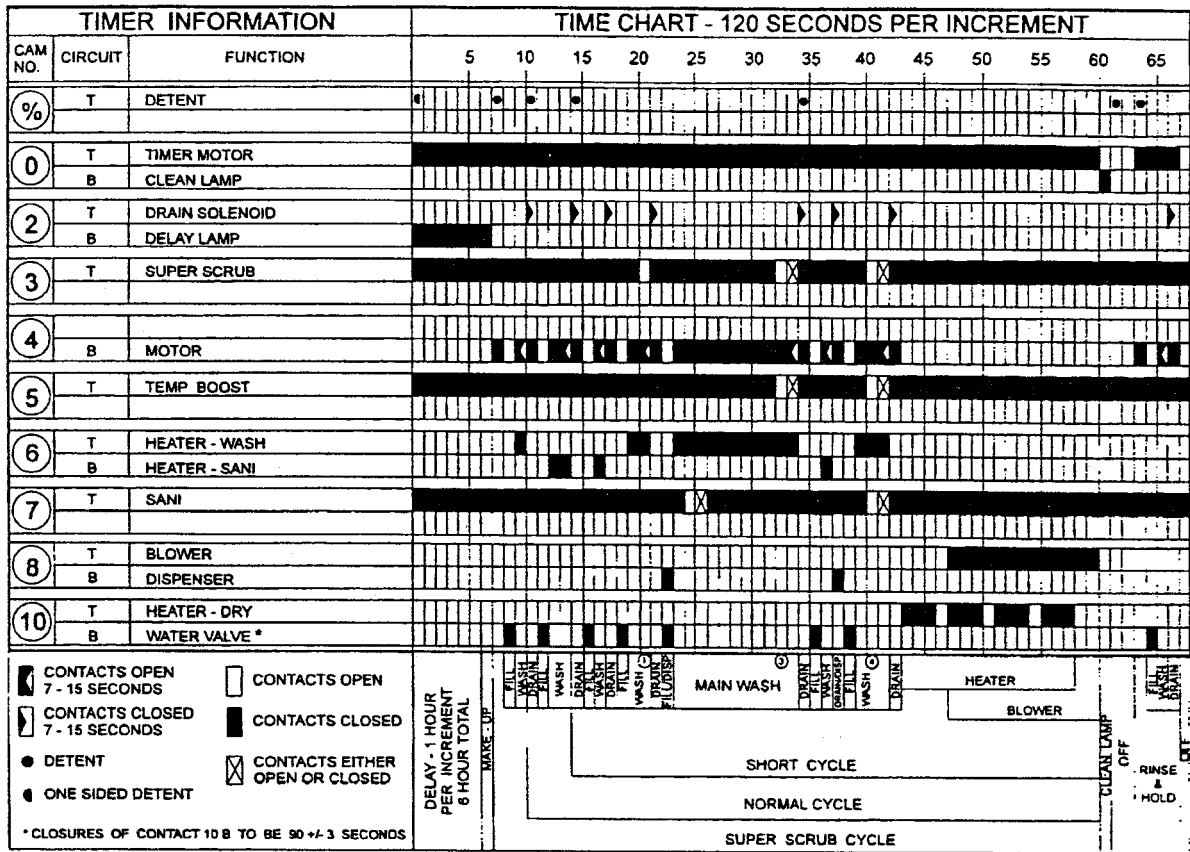

- ① CHECK THERMOSTAT IF SUPER SCRUB SELECTED
- ② CHECK THERMOSTAT IF SUPER SCRUB OR TEMP BOOST SELECTED
- ③ CHECK THERMOSTAT IF SUPER SCRUB OR TEMP BOOST SELECTED

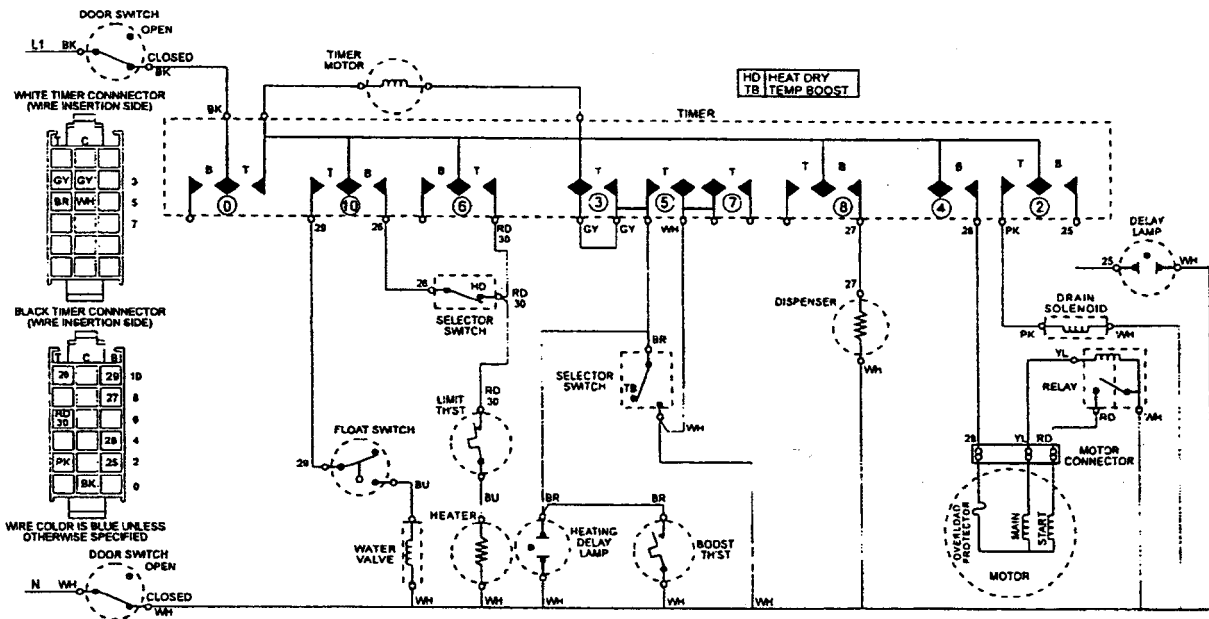

CAUTION

Except as necessary to perform a particular step in servicing a product, the electrical power supply should **ALWAYS** be disconnected when servicing a product.

WIRING DIAGRAM AND SCHEMATIC FOR CDU600

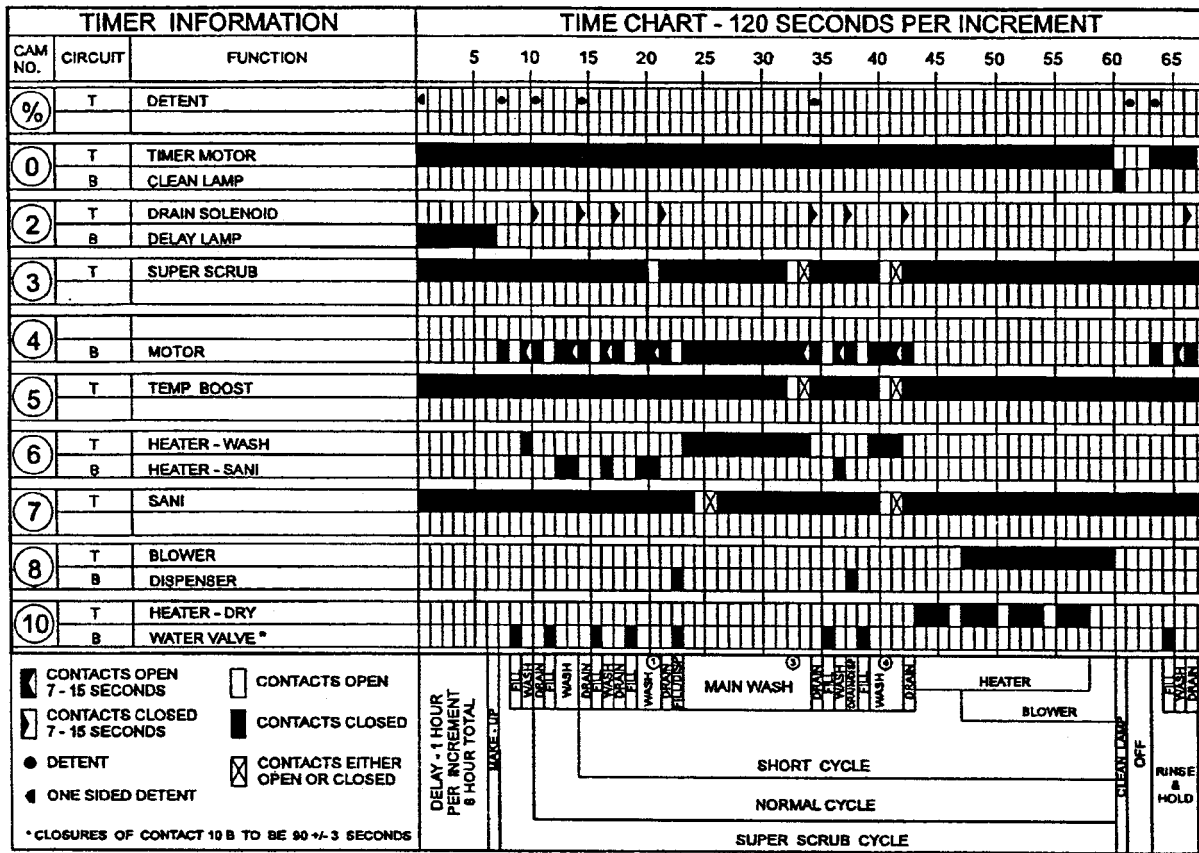

- ① CHECK THERMOSTAT IF SUPER SCRUB SELECTED
- ② CHECK THERMOSTAT IF SUPER SCRUB OR TEMP BOOST SELECTED
- ③ CHECK THERMOSTAT IF SUPER SCRUB OR TEMP BOOST SELECTED

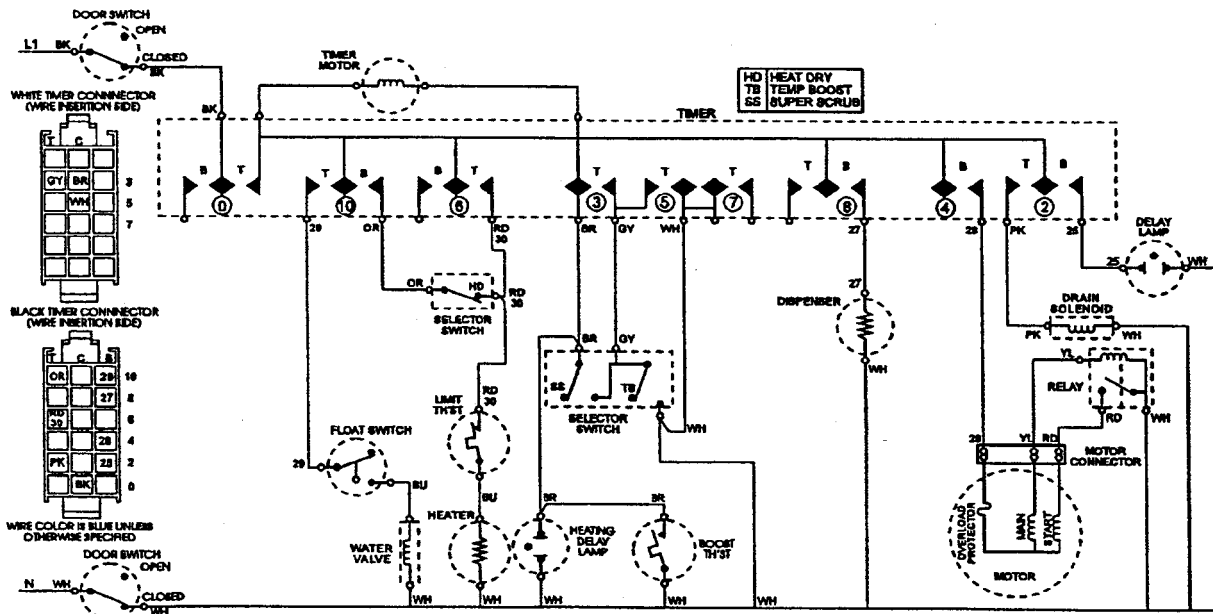

CAUTION

Except as necessary to perform a particular step in servicing a product, the electrical power supply should **ALWAYS** be disconnected when servicing a product.

MAYTAG

Maytag Appliances Sales Company

Customer Service
240 Edwards St.
Cleveland, TN 37311