

**MAYTAG**

**Maytag**  
***Performa***

**Dishwasher**  
**Service Manual**

16010622  
Issued 7/01

---

## GENERAL SAFETY PRECAUTIONS

Information contained in this manual is intended for use by a qualified service technician familiar with proper and safe procedures to be followed when repairing an electrical appliance. All tests and repairs should be performed by a qualified service technician equipped with proper tools and measuring devices. All component replacements should be made by a qualified service technician using only factory approved replacement parts.

Improper assembly or adjustment may occur if service or repair is attempted by persons other than qualified service technicians or if parts other than approved replacement parts are used. Improper assembly or adjustment can create hazardous conditions.

There can be a risk of injury or electrical shock while performing services or repairs. Injury or electrical shock can be serious or even fatal. Consequently, extreme caution should be taken when performing voltage checks on individual components of a product. **PLEASE NOTE:** Except as necessary to perform a particular step in servicing a product, the electrical power supply should **ALWAYS** be disconnected when servicing a product.

Further, this appliance **MUST** be properly grounded. Never plug in or direct wire an appliance unless it is properly grounded and in accordance with all local and national codes. See installation instructions that accompany the product for grounding this appliance.

**USE ONLY GENUINE MAYTAG APPROVED FACTORY REPLACEMENT COMPONENTS.**

### IMPORTANT SAFETY NOTICE AND WARNING

The California Safe Drinking Water and Toxic Enforcement Act of 1986 (Proposition 65) requires the Governor of California to publish a list of substances known to the State of California to cause cancer or reproductive harm, and requires business to warn customers of potential exposures to such substances.

---

# INTRODUCTION

The information presented in this manual is printed in a loose format and is divided into sections relating to a general group of components and/or service procedures. Each section is further subdivided to describe a particular component or service procedure. Anything of a unique nature has been detailed and labeled as such in the manual.

Each page of the manual will be identified in the lower right-hand corner, and as new or revised pages are published, the manual can easily be updated by following the file instructions on the cover letter of the supplement.

## MODELS COVERED IN THIS MANUAL

PDB1600AW\*  
PDB2600AW\*  
PDB3600AW\*  
PDB4600AW\*



---

# CONTENTS

INTRODUCTION .....	i
CONTENTS .....	iii
<b>SECTION 1. ELECTRICAL EQUIPMENT &amp; TESTING .....</b>	<b>1-1</b>
ELECTRICAL TEST EQUIPMENT .....	1-1
Appliance Test Meter .....	1-1
VOLTAGE CHECKS .....	1-2
Motor Test Cord .....	1-2
Grounding and Polarity .....	1-3
ELECTRICAL TESTS .....	1-3
WATER VALVE TEST .....	1-3
WAX MOTOR CHECK - Detergent & Rinse Aid Dispensers .....	1-3
DRIVE MOTOR TEST .....	1-3
<b>SECTION 2. CYCLE &amp; OPTIONS .....</b>	<b>2-1</b>
TIMER MODELS .....	2-1
MICROPROCESSOR MODELS .....	2-2
LED DISPLAYS .....	2-3
<b>SECTION 3. ELECTRICAL-MECHANICAL TROUBLESHOOTING .....</b>	<b>3-1</b>
ELECTRICAL-MECHANICAL CHECKS .....	3-1
All Models .....	3-1
WILL NOT FILL .....	3-1
OVERFLOWS .....	3-1
POOR WATER CIRCULATION .....	3-2
POOR WASHABILITY .....	3-2
WILL NOT DRAIN .....	3-2
CONTINUES TO DRAIN .....	3-3
POOR DRYING .....	3-3
WATER LEAKS .....	3-3
NOISE .....	3-4
Microprocessor Models .....	3-4
WILL NOT START OR PROGRAM .....	3-4
WILL NOT FILL .....	3-5
WILL NOT WASH/DRAIN .....	3-5
WILL NOT DRY .....	3-5
FIELD SERVICE TESTS .....	3-5
Manual Function Test .....	3-5
Automatic Function Test .....	3-6
Sales Floor Demo Mode .....	3-6
<b>SECTION 4. SERVICE PROCEDURES .....</b>	<b>4-1</b>
OUTER DOOR PANEL .....	4-1
ACCESS AND TOE PANELS .....	4-1
INNER DOOR PANEL .....	4-2
DETERGENT & RINSE DISPENSER MECHANISM & RESERVOIR .....	4-2
VENT .....	4-3

WIRE COVER .....	4-3
CONTROL PANEL BARRIER .....	4-4
DOOR LATCH SWITCH HOLDER ASSEMBLY .....	4-4
CYCLE/OPTIONS SWITCH .....	4-5
TIMER .....	4-5
MICROPROCESSOR BOARD (Select Models) .....	4-5
SCHEMATIC .....	4-6
CONTROL CONSOLE FACIA .....	4-6
DOOR LATCH STRIKE .....	4-6
DOOR GASKET .....	4-7
DOOR HINGES .....	4-7
HINGE SPRINGS .....	4-8
Proper Door Tension .....	4-8
UPPER SPRAY ARM .....	4-8
UPPER SPRAY ARM HOSE .....	4-9
FLOAT ASSEMBLY .....	4-9
VENT COVER .....	4-10
SUDS RESERVOIR/CONVECTION VENT INLET .....	4-10
START RELAY .....	4-11
START RELAY CHECKS .....	4-11
HEATING ELEMENT .....	4-11
Wattage Checks .....	4-12
THERMOSTATS .....	4-12
WATER VALVE .....	4-13
Checking Valve Operation .....	4-13
Inlet Screen .....	4-14
WATER INJECTOR .....	4-14
SPRAY TOWER ASSEMBLY .....	4-14
Rack Rollers - Tub .....	4-15
POWER MODULE .....	4-16
PUMP ASSEMBLY .....	4-17
PORTABLE DISHWASHERS .....	4-19
Wood Top .....	4-19
Cabinet .....	4-19
Casters .....	4-20
Faucet Coupler .....	4-20
Retainer - Faucet Coupler .....	4-20
WATER DEFLECTORS .....	4-20
SECTION 5 - GENERAL INFORMATION .....	5-1
SPECIFICATIONS .....	5-1
COMPONENT INFORMATION .....	5-1
ELECTRICAL SCHEMATICS - PDB1600 & PDB2600 .....	5-3
ELECTRICAL SCHEMATICS - PDB3600 & PDC3600 .....	5-4
ELECTRICAL SCHEMATICS - PDB4600 .....	5-5

---

# SECTION 1. ELECTRICAL EQUIPMENT & TESTING

---

## ELECTRICAL TEST EQUIPMENT

The equipment required to service these models depends largely upon the condition encountered. Locating a malfunction will often require the use of electrical testing equipment such as:

Appliance Test Meter  
Clamp-On Ammeter  
Motor Test Cord

---

### Appliance Test Meter

An Appliance Test Meter is a multi-purpose tester combining an AC/DC voltage tester with a multi-range ohmmeter.

The easiest means of testing electrical components is "continuity testing" with an appliance meter. Continuity is a complete or continuous path from one point in an electrical circuit to another.

The obvious advantages of being able to check electrical components and circuits without power applied is one of the features of the ohmmeter. Multiple ranges allow accurate determination of resistances of both single components and entire circuit paths. Resistance is measured in "ohms."

**CAUTION:** *Always be sure the power has been disconnected before making resistance measurements. Failure to do so will result in damage to your meter! Internal batteries provide all the power needed to make resistance checks. They should be checked at least once a year and replaced as needed.*

Continuity Testing is a process of eliminating electrical components involved in a given function of the appliance, until the inoperative part is found. By reviewing the list of possible electrical problems under a

given condition, and then performing appropriate continuity checks of the parts involved, you should be able to locate the electrical component which is inoperative.

**NOTE:** *When checking components or circuit paths for continuity, external wiring should be disconnected to eliminate false readings through external paths. Isolate what you want to test.*

Digital Test Meter can be used to check for open or closed circuits, measure resistance, AC and DC volts, and temperature.

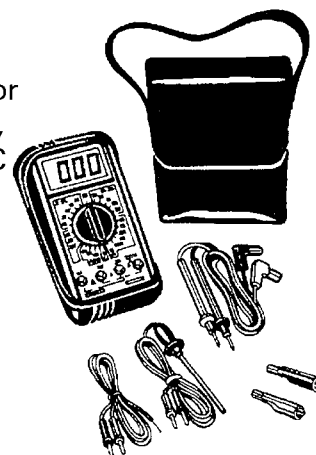

Analog Test Meter can be used to check for open or closed circuits, measure resistance, AC and DC volts, and temperature.



---

## VOLTAGE CHECKS

Generally, these checks will consist of taking readings at the wall receptacle in order to determine the availability of voltage to the product. Voltage checks on individual components of a product are not recommended due to the possibility of electrical shock. Component part testing is best accomplished through continuity checks with an Appliance Test Meter.

*NOTE: Use of the meter on voltage higher than the indicated range may cause permanent damage to the meter. To prevent damage, first select highest range and then lower the range for readings which fall within the lower scale.*

Clamp-On Ammeter can be used to detect shorts. Overloads on the circuit breaker or fuse can be traced to either the appliance or circuit breaker by checking the current draw.

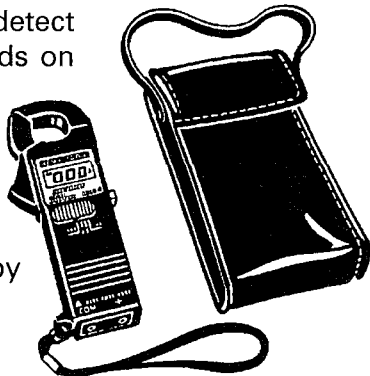

Each circuit in an appliance has a "normal" current draw, which is an indication of the performance of that circuit. Current draw levels of less than or more than normal give clues to possible malfunctions. The clamp-on ammeter measures these circuits without breaking the circuit by measuring the strength of the magnetic field developed around each conductor. Current is read by separating the conductors and clamping the jaws of the ammeter around each conductor on which current is read. Low amperage readings indicate problems, such as damaged heating elements, etc. High amperage readings indicate the unit being tested is operating under an increased mechanical or electrical load.

*NOTE: Overloads on a circuit breaker or fuse can be traced to the product being tested or the circuit breaker (or fuse) by checking the products current draw. If the amperage reading is less than the breaker reading, the breaker or fuse box is at fault.*



*Warning - Always shut off electrical power to the appliance before beginning any service repair procedures.*

Use of Ammeter on dishwasher:

1. Motor Current - the reading can be taken at the leads on the motor start relay or at the male connector.
2. Heating Element Current - The reading can be taken using either lead to the element.

---

## Motor Test Cord

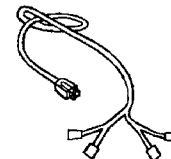

A motor test cord may be used to electrically check operation of the various electrical components without removing them from the unit. Testing in this manner merely determines whether or not the part will function independently of other electrical components. In order to make accurate tests, proper connection of the motor test cord is important. With the aid of the drawings under Drive Motor Test, installation of the motor test cord may be done quickly and accurately.

*NOTE: Always plug test cord into a properly grounded receptacle.*



---

## Grounding and Polarity

The receptacle used for all Maytag products operating on 120 VAC must be properly grounded and polarized.

The power cord used on the appliances should be equipped with a three (3) prong polarized grounding plug for protection against shock hazard and should be plugged directly into a properly grounded and polarized receptacle.

**DO NOT CUT OR REMOVE THE GROUNDING PRONG FROM THIS PLUG.**

It is the responsibility of the person installing the appliance to assure it is adequately grounded and polarized at the point of installation, taking into consideration local conditions and requirements. In cases where only a two (2) prong receptacle is available, it is the personal responsibility of the consumer to have it replaced with a properly grounded three (3) prong receptacle. All grounding and wiring should be done in accordance with National, State, and Local codes. **USE OF ADAPTERS IS NOT RECOMMENDED.**

---

## ELECTRICAL TESTS



**WARNING** - Always shut off electrical power to the appliance before beginning any service repair procedures.

---

### WATER VALVE TEST

The water valve may be checked without removing it from the dishwasher.

To check the water valve for operation, hook up the test cord as follows:

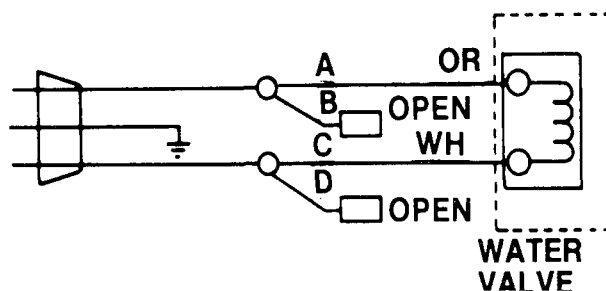

---

### WAX MOTOR CHECK -

Detergent & Rinse Aid Dispensers

A single wax motor is used to activate both the release of the detergent cup cover and the rinse aid from the reservoir.

To check the operation of the wax motor, removal from the dispenser retainer or inner door is not necessary.

First, snap the detergent cup door shut. Then, connect a power test cord across the two terminals of the wax motor. Plug the power test cord into a 120 VAC receptacle. The plunger in the center of the wax motor should "push out" and actuate the dispenser in approximately 45-60 seconds. Remove voltage to the wax motor and allow the plunger to retract into the wax motor. Apply voltage to the wax motor again and observe for proper lifting of the rinse aid plunger.

---

### DRIVE MOTOR TEST

An external start relay and a connector are used to couple the wire harness to the motor wires.

The start relay is mounted on the ceiling of tub support and consists of a coil and a switch. The coil is in series with the main winding in the motor. When the motor is first energized, the current draw in this series circuit is enough to close the switch in the start relay. This closed switch provides a path for neutral for the start winding and the motor starts. Once the motor is up to speed, the current draw decreases and the coil can no longer hold

the switch closed. When the switch opens, the start winding drops out of the circuit.

NOTE: *The relay has to be in an upright position to work properly.*

To test the motor, the connector needs to be separated. This can be done by pushing out

the latches on each end of the motor connector and pulling at the same time. The following drawings will help make the proper connections for testing.

Plug test cord into properly polarized and grounded receptacle.

### DRAIN CYCLE

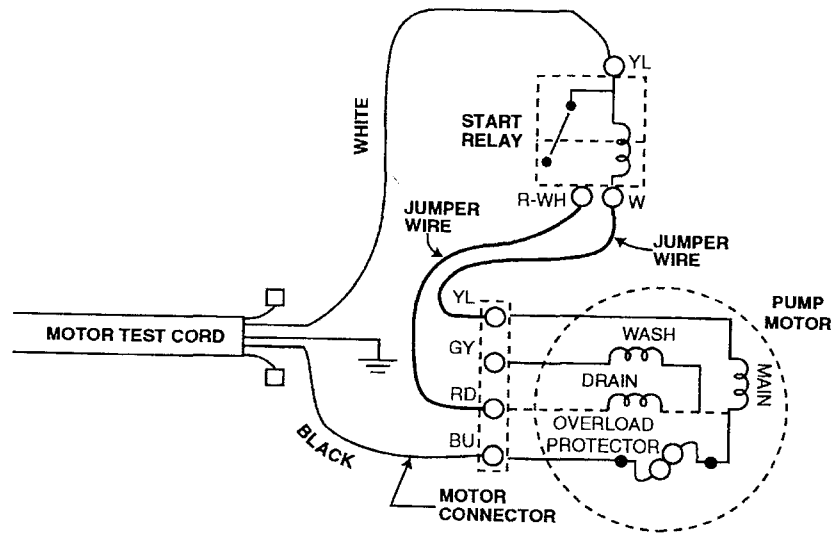

### WASH CYCLE

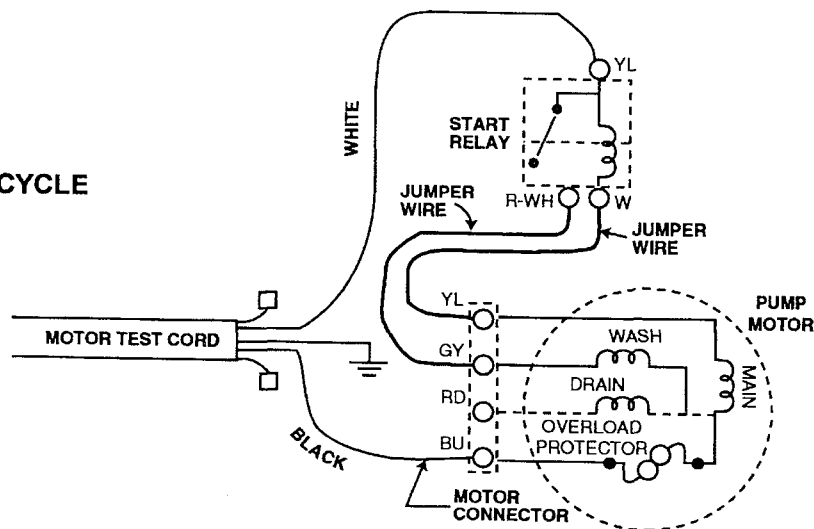

NOTE: *DAMAGE TO THE MOTOR WILL RESULT IF THE START RELAY IS BYPASSED AND THE TEST CORD IS ATTACHED DIRECTLY TO THE MOTOR CONNECTOR.*

Extreme caution should be taken when performing voltage checks due to danger of possible electrical shock. Except as necessary to perform a particular step in servicing a product, the electrical power supply should ALWAYS BE DISCONNECTED WHEN SERVICING A PRODUCT.

---

## SECTION 2. CYCLES & OPTIONS

---

### TIMER MODELS

Cycle	Description
Heavy Wash	Designed to provide a longer cycle for washing items with heavy food soils.
Normal Wash	Designed to wash loads containing dishes with normal amounts of food soils.
Light Wash	Designed to wash loads containing dishes that are lightly soiled.
Rinse Only	Rinses dishes being held until the dishwasher is full, and another cycle is selected. This cycle helps reduce the potential for development of odors.

Option	Description
Temp Boost	When switched to the "ON" position, checks the main wash and final rinse temperatures and will extend the heating and water circulation until the proper water temperature is reached. When the wash or rinse portions of the cycle are extended, the "Heating Delay" light will illuminate.
Extended Wash	Provides a water temperature check early in the main wash and also in the final rinse portion of the cycle. If necessary, the heating element turns on and the cycle is extended until the water reaches proper temperature.
Heated Dry	When switched to the "ON" position, improves drying results by turning the heating element on and off during the dry portion of the cycle.
Delay Hours	Delays the start of the dishwasher for a period of approximately 1 to 6 hours. NOTE: <i>When using this option, the dishwasher will run a Heavy Wash cycle.</i>

---

## MICROPROCESSOR MODELS

The dishwasher cycles are activated by pressing any cycle pad on the control panel. All cycles begin with a 5 second pause to allow a consumer to select the "Delay" feature. When a cycle has been selected, an indicator light above the pad will illuminate and a short beep will sound. This indicates the dishwasher control has responded to the selection. Also, the cycle length in minutes will appear in the display. The cycle selection may be changed only within the first 60 seconds of the initial cycle selection. After this time, the cycle keys are locked out until the cycle has been completed or the "Drain/Off" pad is selected.

Cycle	Description
Heavy Wash	Designed to provide a longer cycle for washing items with heavy food soils.
Normal	Designed to wash loads containing dishes with normal amounts of food soils
Light	Designed to wash loads containing dishes that are lightly soiled.
Rinse Only	Rinses dishes being held until the dishwasher is full and another cycle is selected. This cycle helps reduce the potential for development of odors.
Option	Description
Delay/Resume	To delay the start of a cycle, first select a cycle to be run then press the "Delay" pad until the desired delay time LED is illuminated. If delay is chosen without first selecting a cycle, the last cycle chosen will run when the delay times out. The delay will not time out with the door unlatched. Depressing the "Delay/Resume" pad during a cycle will pause the dishwasher. Depressing the pad again will resume the cycle.
Accu Temp	This option may be selected or deselected within 1 minute of choosing a cycle. When selected, the main wash and last rinse portion of the cycles are extended until the proper water temperature is reached. If water temperature is not reached within 20 minutes of delaying, the cycle will proceed into the next segment. When the wash or rinse portion of the cycle is extended, the "Heating Delay" light will illuminate.

Heated Dry	This option may be selected or deselected at any time during the Power Scrub, Normal, and Light/China cycles. In the "Quick" cycle, this option cannot be changed after the first minute of operation. For the "Rinse & Hold" cycle, this option is not available. During the dry portion of the cycle, the heater will pulse on and off.
Drain/Off	This cancels any cycle and initiates a drain after a 2 second pause. Pressing the key pad a second time will terminate all functions immediately.

---

## LED DISPLAYS

### Clean

LED will be on from the end of the dry cycle until the door has been open continuously for approximately 30 seconds. The Drain/Off keypad when depressed will also turn off the Clean LED.

### Drain/Off

LED will be on only when drain has been initiated using the Drain/Off keypad.

### Dry

LED will be on throughout the dry cycle.

### Heating Delay

LED will be on when the dishwasher is waiting for the water to heat up to the proper temperature.

### Heavy Wash, Normal Wash, Light Wash, Rinse Only

LED is on when corresponding cycle is in progress.

### Wash

LED will be on during the wash and rinse portion of the cycle.

### Accu Temp, Heated Dry

LED is on when option is selected.



---

# SECTION 3. ELECTRICAL-MECHANICAL TROUBLESHOOTING

---

## ELECTRICAL-MECHANICAL CHECKS



**▲ WARNING** *Warning* - Always shut off electrical power to the appliance before beginning any service repair procedures.

---

### All Models

The following are electrical and mechanical checks for all dishwashers, except for microprocessor controlled systems. Microprocessor models will be covered later in this section.

WILL NOT FILL

#### Water Access Valve

Check to determine if the valve is turned on and water is available to the dishwasher. Check water pressure.

#### Circuit Breaker/Fuse

Check for tripped breaker or blown fuse. Reset or replace as necessary.

#### Door Latch

Check door latch for adjustment, and door switches for continuity. With door switches engaged, no continuity, replace switch.

#### Float

Check float position. If in the up position, check for obstruction or disengagement from the float switch arm.

#### Float Switch

If the float is in the down position, check the switch for continuity. If no continuity, replace the float switch.

#### Water Valve

Check solenoid for continuity. No continuity, replace water valve. Check inlet screen for restrictions. Clean screen or replace water valve as necessary.

#### Selector Switch

Check switch contacts for continuity per electrical schematic. Replace switch if necessary.

#### Timer

Check timer contacts for continuity per electrical schematic. Replace timer if necessary.

#### Wiring/Electrical Connections

Check for loose or frayed wire terminal connections. Check for broken wire within harness. Repair or replace as necessary.

OVERFLOWS

#### Water Valve

Check that water continues to flow when electrical power is turned off. If the water continues to flow without electrical power, replace water valve.

*NOTE: Low water pressure can result in failure of the water valve to close properly.*

#### Float

Ensure that the float isn't stuck in the down position. Check for sediment buildup. Clean and/or replace as necessary.

#### Float Switch Actuator Lever

Check the actuator lever on the bracket. It must be able to move freely. Repair or replace as necessary.

#### Float Switch

Check float switch for continuity with the float in the up position. If continuity is present and float moves up and down freely, replace float switch.

### POOR WATER CIRCULATION

#### Seal Ring

Check the seal ring between the lower spray arm and spray arm support on pump module. If out of position or damaged, reposition or replace.

#### Water Level - Too Low

Check the water level. Water should be at a level where it just comes in contact with the heating element.

#### Pump Assembly

Check assembly for obstructions or restricted movement of parts. Repair and/or replace parts as necessary.

#### Filters

Check for blockage of strainer, primary filter, and filter support. Repair as necessary.

### POOR WASHABILITY

#### Spray Arms

Check upper and lower spray arms for blockage of water ports or cracks. Check for proper rack loading to avoid interference with spray arms during wash action. Check for proper sealing, fastening, and movement of spray arms. Repair as necessary.

#### Filters

Check for blockage of strainer, primary filter, and filter support. Repair as necessary.

#### Detergent Cup Cover

Check spring hinge operation of detergent cup cover. Repair as necessary.

#### Detergent Cup

Check operation of detergent cup assembly wax motor, actuator, linkage, and cover latch. Repair and/or replace parts as necessary. Note: *For testing of wax motor, see Section 2.*

#### Rinse Dispenser

Check level of rinse aid in reservoir. Check plunger for proper alignment and mating to the top of the reservoir. Check rinse dispenser cap for residue build up on end of stem. Clean and/or replace parts as necessary.

#### Timer

Check dispenser timer contacts for continuity per electrical schematic. If no continuity, replace timer.

### WILL NOT DRAIN

#### Inadequate Drainage

Check the drain pipe that the drain hose connects to and repair as needed. If draining into the garbage disposal, check for unprocessed food waste at drain hose connection to disposer. Clean out as needed.

#### Drain Hose

Check drain hose for kink or restrictions. Reroute or remove any restriction of drain hose as needed.

#### Pump Assembly

Check pump assembly for obstructions or restricted parts. Repair or replace parts as necessary.

#### Timer

Check timer contacts for continuity for motor operation per electrical schematic. If no continuity is present, replace timer.

#### Wiring/Electrical Connections

Check for loose or frayed wire terminal connections. Check for broken wire within harness. Repair or replace as necessary.



### Pump Motor

Check motor and motor relay. Check for proper voltage. If voltage is below 105 VAC, check incoming house wiring. Replace motor or motor relay as needed. NOTE: *For proper testing of motor, see Section 2.*

## CONTINUES TO DRAIN

### Siphoning

Check for proper elevation of drain hose. Drain hose must reach a height of 32 inches above the floor. Check for air gap installation. Repair as needed.

### Timer

Check timer for advancement. If timer motor is not running, or timer motor is running but not advancing, replace the timer.

## POOR DRYING

### Water Temperature

Check for low water temperature. Temperature should be between 120 - 150 degrees Fahrenheit. If not, advise consumer to adjust water heater setting. Encourage consumer to purge water lines to the dishwasher area prior to starting the dishwasher.

### Cycle Options

Advise consumer use of options available on dishwasher that improve drying. Options that improve drying are Heated Dry, and Temp Boost/Accu Temp.

### Detergent

Check water hardness. Instruct consumer on detergent usage, one teaspoon of detergent per grain of water hardness.

### Rinse Dispenser

Check level of rinse aid in reservoir. Check plunger for proper alignment and mating to the top of the reservoir. Check rinse

dispenser cap for residue build up on end of stem. Clean and/or replace parts as necessary.

### Improper Rack Loading

Check how the consumer loads the dishes into the racks. Improper loading of some types of dishes can trap water which causes dishes not to dry.

### Heating Element

Check for continuity of element, terminal to terminal. No continuity, replace element. Check terminal to element sheath. If no continuity, replace the element.

### Thermostat

Check mating surface of the High Limit thermostat face to surface of tub enclosure, must be flat. Adjust the thermostat placement if necessary. Check continuity of thermostats, high limit and temp boost/accu-temp (*See Section 5 - General Information for thermostat specifications*). Replace as necessary.

### Selector Switch

Check continuity between switch terminals for options selected per electrical schematic. If no continuity, replace the switch.

### Timer

Check timer contacts for continuity per electrical schematic. If no continuity, replace the timer.

## WATER LEAKS

### Installation

Check dishwasher for proper leveling and squareness in cabinet.

### Door Alignment

Check proper alignment of door liner to door gasket. Use chalk rubbed onto rib of liner, close, then open door. Observe chalk markings on door gasket. Adjust door hinges or leveling legs to align door into

center of gasket. Before tightening screws, pull door assembly toward the front, then tighten screw to 75 in. lbs.

#### Door Gasket

Check door latch for proper adjustment. Check for torn or damaged door gasket. Adjust, repair or replace as necessary.

#### Hoses

Check for loose hose clamps or hoses that leak. Tighten hose clamps or replace hoses as needed.

#### Spray Arms - Upper & Lower

Check for cracks and replace as necessary.

#### Detergent Lid Latch Grommet

Check the lid latch grommet for proper positioning or cracking. Replace if necessary.

#### Dispenser Seal

Check rinse aid dispenser seal for proper positioning or cracking. Reposition or replace as needed.

#### Water Valve

Check water valve body for damage and leaks. Replace if necessary. Also, check plumbing connections to water valve.

#### Pump Assembly

Check for water leak between pump assembly and tub. If gasket is leaking, adjust locking ring to increase tension of pump assembly to tub. Check pump assembly housing for cracks, housing seal and seal seat for leaks. Repair or replace parts as necessary.

### NOISE

**NOTE:** *Before servicing the unit, check that noise is not normal operating sound.*

#### Banging

Check for loose upper and lower spray arms. Check for dishes interfering with spray arm rotation.

#### Hammering/Chattering

Check water valve for, noise, low voltage, or high valve coil resistance. Replace water valve if needed. Also, check incoming water supply line for proper size and pressure. Make sure the supply line is secured.

#### Grinding

Check for objects in pump assembly. If objects are found, inspect pump assembly for damage. Repair as needed.

#### Vibration

Check components for source of vibration. Adjust and/or tighten as needed.

---

### Microprocessor Models

The following checks are unique to microprocessor models. Prior to following any of the diagnostics listed, follow troubleshooting steps on page 3-7.

### WILL NOT START OR PROGRAM

With the door unlatched and depressing a cycle keypad, the cycle will not activate. When the door is latched, depress any cycle key pad. The corresponding LED should illuminate. If not, check the following:

#### Microprocessor

Check for 120 VAC input voltage to the board from the black wire to the white wire. If no voltage is present, check the wiring back to the door switches.

**NOTE:** *Make sure the connectors are making proper contact with terminals on the board. If the voltage is correct into the board, and the board will not activate, replace the board.*

WILL NOT FILL

Check the water valve circuit. Check for continuity between terminal 6 (blue wire) of the 6 pin connector and the black wire terminal on the board. If no continuity, check float and water valve. If continuity is present, replace the board.

NOTE: *Make sure the pin connector is making proper contact with the pins on the board.*

WILL NOT WASH/DRAIN

Drive Motor

Perform continuity check of the motor windings at the board. Check the drain start windings (red to blue), wash start windings (gray to blue), and the main windings (yellow to blue). If no continuity is found, replace motor pump assembly. If continuity is present, hook up motor test cord and verify motor operation. If motor operates properly replace board.

NOTE: *See section on Electrical Test Equipment.*

WILL NOT DRY

Check board heater circuit by implementing the Manual Function Test and then depressing key pad #6. There should be line voltage across the heating element terminals. If no voltage is present, check output voltage from the board. Check from the orange wire to the white wire. If no voltage is present, replace the board. If voltage is present, check hi-limit thermostat and wiring harness.

Check board dispenser circuit by implementing the Manual Function Test and then depressing key pad #4. There should be line voltage across the terminals of the wax

motor for the dispenser. If no voltage is present, check the output voltage from the board. Measure the voltage across terminal #5 of the 6 pin connector and black wire on the board. There should be line voltage. If no voltage is present, replace the board.

Note: *Make sure the pin connector is making contact with the pins on the board.*

\* When checking the wax motor for the dispenser, see Section 1, Electrical Equipment and Testing, for instruction.

---

## FIELD SERVICE TESTS

The microprocessor board incorporates two functional tests and a "Sales Demo" function. The tests comprise of the Manual Function Test and Automatic Function Test.

---

### Manual Function Test

This test will allow the technician to manually function the individual components of the dishwasher. When a specific key pad is pressed, the component will activate (on) and pressing the key pad again will deactivate the component (off).

To start this test, press key pads in the following sequence within 10 seconds:

Key pad #2  
Key pad #1  
Key pad #2  
Key pad #3  
Key pad #4  
Key pad #5  
Key pad #6  
Key pad #7  
Key pad #4

The "Dry LED" will flash indicating the manual test mode is active.

The following key pads will manually function the corresponding components:

Key pad #2 Motor Circulate  
Key pad #3 Water Valve  
Key pad #4 Detergent Lid/Rinse Aid  
Key pad #6 Heating Element

The test will automatically cancel 120 seconds after the last key pad is pressed. To cancel test and drain the dishwasher, press the "Drain/Off" key pad.

---

### Automatic Function Test

This test will allow the technician to perform a very quick functional check of the main components of the dishwasher.

To start this test, press key pads in the following sequence within 10 seconds:

Key pad #2  
Key pad #1  
Key pad #2  
Key pad #3  
Key pad #4  
Key pad #5  
Key pad #6  
Key pad #7  
Key pad #1

The "Wash LED" will flash indicating the automatic test mode is active.

The following functions will automatically occur for the prescribed amount of time:

20 seconds Water Valve (partial fill)  
5 seconds Pause  
120 seconds Motor, Heating Element, Wax  
Motor for Detergent Lid  
6 seconds Motor Pause  
5 seconds Pause  
50 seconds Motor Drain

"LED"s will light up one at a time progressively until all are lit, and then simultaneously will go off (except wash LED) and will repeat throughout the duration of the test. If the door is opened

during the test, the test sequence will pause and will resume when the door is closed. The door must be closed within 30 seconds. To cancel the test, press the "Drain/Off" key pad.

The control has been designed to also check the Thermister and Motor current during this test mode. If during the test a fault is detected, the test mode will abort and 2 LED's will flash..

The "Clean" LED and one of the following depending on the failure detected:

Thermister - Open - key pad # 5 LED  
Thermister - shorted - key pad # 4 LED  
Motor - High Current - key pad # 3 LED  
Motor - Low Current - key pad # 2 LED

---

### Sales Floor Demo Mode

Press "Rinse Only" key pad 5 times within 5 seconds. The LED's will sequence at a 1 second rate as follows:

Clean  
Dry  
Wash  
Heating Delay  
2 HR  
4 HR  
6 HR  
Rinse Only  
Light Wash  
Normal Wash  
Heavy Wash  
Temp Boost / Accu Temp  
Heated Dry  
Drain / off

This mode will keep repeating until canceled.

To cancel, press "Drain / Off" key pad twice.

## SECTION 4. SERVICE PROCEDURES

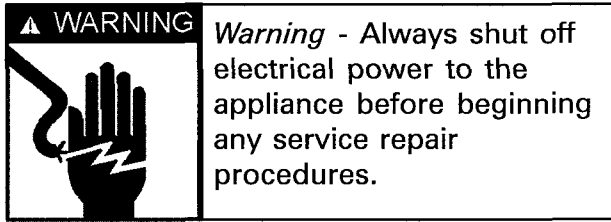

EXTREME caution should be taken when performing voltage checks due to danger of possible electrical shock. Except as necessary to perform a particular step in servicing a product, the electrical power supply should always be disconnected when servicing a product.

### OUTER DOOR PANEL

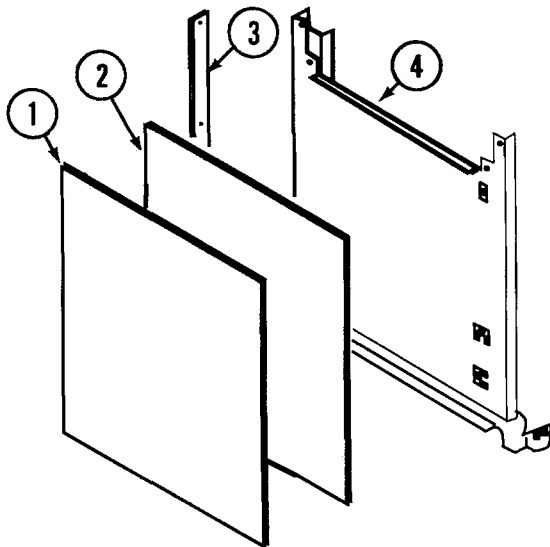

Figure 4-1

No.	Description
1	Front Insert
2	Front Filler
3	Door Trim
4	Door Panel

### Removal

1. Disconnect power to the machine.
2. Remove three screws holding the trim strip on one side of the door. Take note of how the trim is removed.
3. Grasping the lower part of the door panels, bow panel out carefully at the bottom while sliding panels far enough to clear the flange on the trim strip which was not removed. Remove panels.
4. Arrange panels so that the desired color is facing out.
5. Place door panels (notched side up) behind the metal trim at the bottom of the door. Bow the panels so they fit behind the control panel at the top.
6. Slide the panels under the side metal trim which was not removed. It may be necessary to compress the backing behind the colored panels.
7. Reinstall the trim which was removed earlier. Align the holes and replace three screws.

### ACCESS AND TOE PANELS

Removal of access and toe panels will allow access to the water valve, float switch assembly, door spring adjustment screws, electrical junction box, hoses, thermostats, start relay and motor/pump assembly.

### Removal

1. Disconnect power to the machine.
2. The lower access panel is held by 4 screws, two above the panel, and two below. Remove all four screws.

3. Toe panel can now be removed.
4. To reinstall the panels, place toe panel against the legs of the dishwasher, aligning the holes of the panel with holes in legs and hinge support. Install the 4 screws.

**NOTE:** When installing access panel mounting screws, be sure to use the original screws. Using the wrong screws can result in damage to the tub.

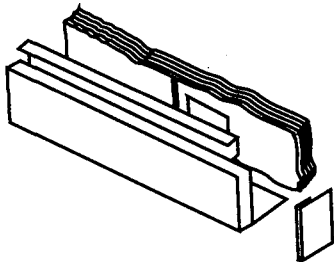

Figure 4-2

## INNER DOOR PANEL

Removal of the inner door panel will allow access to the timer or microprocessor board, door switches, selector switch, indicator lights, and detergent / rinse aid dispenser.

### Removal

1. Disconnect power to the machine.
2. Open the dishwasher door.
3. Remove the 7 Torx screws along the sides and top of the inner door.
4. Separate the inner door panel from the outer door.
5. Disconnect wires from the dispenser wax motor before pulling the inner door panel away from the dishwasher.
6. To reinstall the inner door panel, attach the wiring to the wax motor. Lay the inner door panel on the outer door and install 7 Torx screws.

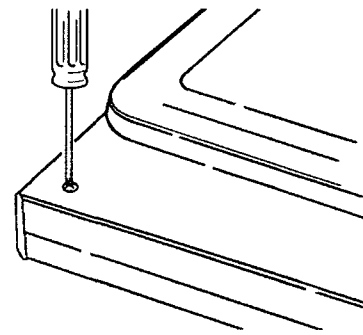

Figure 4-3

## DETERGENT & RINSE DISPENSER MECHANISM & RESERVOIR

### Checking Operation

1. Disconnect power to the machine.
2. Remove the inner door panel.
3. Remove the wax motor and snap the detergent door shut.
4. Gently move the slider of the dispenser mechanism to the left until the detergent door releases. Release the slider.
5. Slide the slider to the left again. Now the actuator will lift the rinse aid plunger. If not, proceed to the next step.

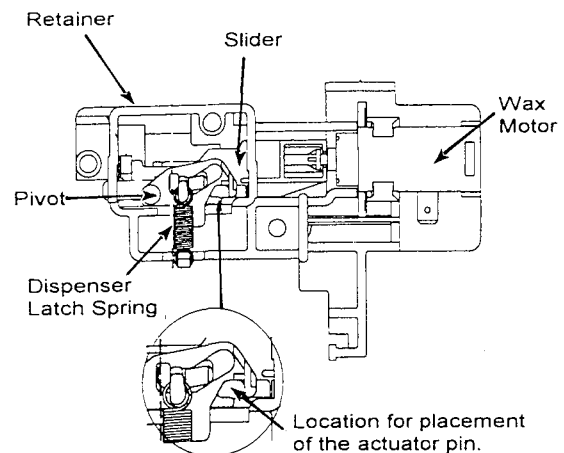

Figure 4-4

6. Examine the linkage of the actuator pin to the pivot and slider.

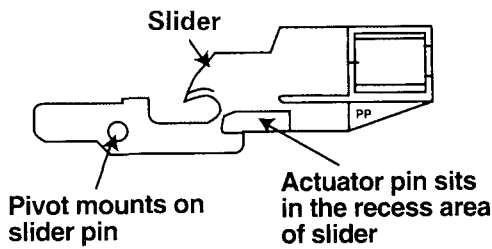

Figure 4-5

NOTE: When reassembling, the pin on the actuator should be engaged on the left side of the armature of the pivot and into the recessed slot on the slider.

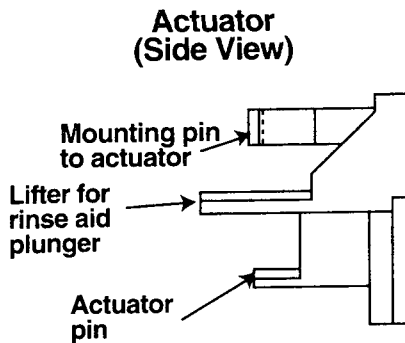
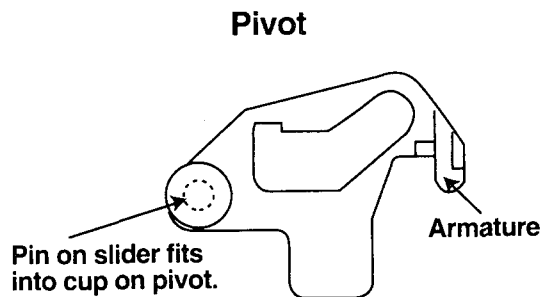

Figure 4-6

#### Mechanism Removal

1. Disconnect power to the machine.
2. Remove the inner door panel.
3. Remove the mounting screw securing the mechanism to the inner door. Slide mechanism off the reservoir.
4. To remove the wax motor, expand the retainer tabs and slide the motor from the mechanism. When replacing, ensure

the piston is securely clipped onto the dispenser actuator arm.

#### Reservoir Removal

1. Disconnect power to the machine.
2. Remove the inner door panel.
3. Remove the rinse aid fill knob. Remove the nut securing the reservoir to the inner door panel.
4. Remove the actuator by pulling straight out. Remove dispenser.
5. The plunger is located on top of the reservoir. To remove, twist plunger so that the exposed tabs are clear of the retaining tabs. When reinstalling, make sure the tabs of the plunger are under the retaining tabs of the reservoir.

---

#### VENT

The vent is located on the inner door panel to allow moisture to be vented outside of the dishwasher during the dry cycle.

The vent grid is removable and replaceable.

#### Vent Grid Removal

1. Disconnect power to the machine.
2. Remove the inner door panel.
3. Remove 2 torx screws securing grid to the inner door.
4. Remove vent grid.

---

#### WIRE COVER

The wire cover retains the wire harness within the door assembly. It is located in the lower right hand corner of the door.

#### Removal

1. Disconnect power to the machine.

- Slide the lower portion of cover to the left, disengaging from the locking tab on the door.
- Lift off cover.
- When reinstalling, place the cover on the door using the locating tab. Slide the cover to the right, locking the cover into place.

---

## CONTROL PANEL BARRIER

The control panel barrier shields the control console components.

### Removal

- Disconnect power to the machine.
- Remove the inner door panel.
- Depress the retainer tab on the left side of the barrier.
- Lift up barrier, left side first. Disengage the solid tab on the right side of the barrier. Remove the barrier.

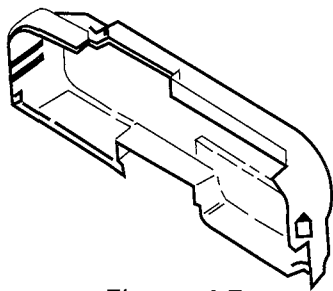

Figure 4-7

---

## DOOR LATCH SWITCH HOLDER ASSEMBLY

Two door switches are used in the latch assembly. Both switches are normally OPEN and will close only when engaged by the door latch hook mechanism. Each switch is in series with respect to L1 and neutral line operations. Failure of either or both switches will result in rendering the dishwasher inoperative. **NOTE: Door switches require no field adjustment.**

### Removal

- Disconnect power to the machine.
- Remove the inner door panel.
- Remove metal reinforcement strip.
- Remove the control panel barrier covering components.
- Remove the mounting screw on left side of latch assembly. When reinstalling latch assembly, fasten with screw to left side first.

### Disassembly

- Disconnect power to the machine.
- Remove the inner door panel.
- Remove metal reinforcement strip.
- Remove the control panel barrier covering components.
- To remove switch, lift retainer tab behind the switch and depress actuator button on switch. While lifting tab, pull switch from holder. To reinstall, lift retainer tab and insert switch into holder.
- To remove latch handle, depress two retainer tabs on switch holder. Then, lift handle.

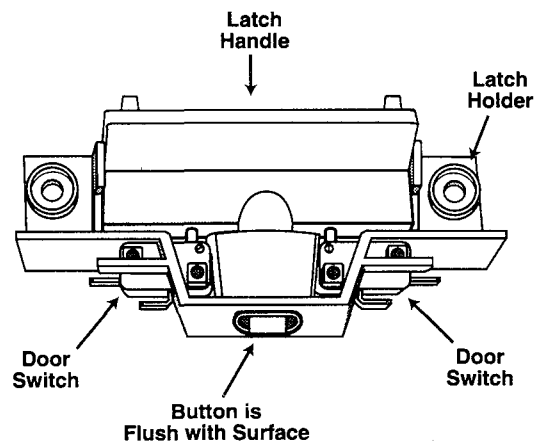

Figure 4-8



---

## CYCLE/OPTIONS SWITCH

The cycle/options switch is located on the control console. It is used to select various cycles and cycle options.

### Removal

1. Disconnect power to the machine.
2. Remove the inner door panel.
3. Remove metal reinforcement strip.
4. Remove the control panel barrier covering components.
5. Disconnect wire leads to the switch.
6. Remove hex head screw on each end of switch.
7. To reinstall switch, reverse the previous order. Refer to electrical schematic for proper wire placement on the switch.

---

## TIMER

Before replacing timer, refer to heading labeled Schematic. Timer circuits are illustrated in the electrical schematics included in this manual. Timer can only be replaced as an assembly.

### Removal

1. Disconnect power to the machine.
2. Remove timer knob by grasping and sliding off shaft of timer.
3. Remove the inner door panel.
4. Remove metal reinforcement strip.
5. Remove the control panel barrier covering components.
6. Remove hex head screws securing timer to control console.

7. Remove electrical disconnect block(s) from timer. To do so, locate retainer tabs on each end of block, squeeze tabs and pull block straight out. Check wire terminals in block to ensure they are positioned securely.

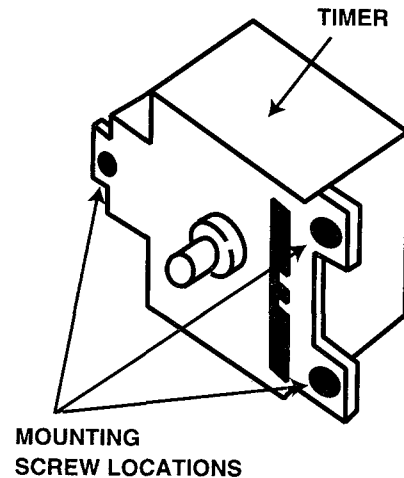

Figure 4-9

---

## MICROPROCESSOR BOARD (Select Models)

### Removal

1. Disconnect power to the machine.
2. Remove the inner door panel
3. Remove metal reinforcement strip.
4. Remove control panel barrier covering components.
5. Remove wire harness connector and wiring from board.
6. Remove hex head screws securing control board assembly to control panel. The screws are located on the relay board section of the control.
7. Unsnap control board housing assembly from control panel and lift out.

---

## SCHEMATIC

The dishwasher schematic is located behind the access panel. The schematic diagram is unique to each model and contains the following information:

Timer Sequence Chart

Harness Connector Identification

Electrical Connection Diagram

Using the Timer Sequence Chart:

The sequence chart used in conjunction with an ohmmeter can be quite effective when attempting to verify or diagnose problems with the timer, wiring, or other electrical components. Example:

1. Identify cycle on chart where problem occurs.
2. Trace down on the chart the timer contacts indicated CLOSED to identify the electrical circuits involved.
3. Perform a "point to point" continuity check of timer terminals to verify whether corresponding contacts are CLOSED or OPEN when advanced to that cycle position. If contacts do not correspond to Sequence Chart, replace timer.
4. If timer checks verify that timer is good, perform a "point to point" continuity check of the timer's electrical connector. This will isolate the trouble in the wiring or the components.

---

## CONTROL CONSOLE FACIA

The facia on the control console may be replaced on Select Models. Other models will have to have the entire control console replaced. Metal facias are replaceable, Polycarbonate facias are nonreplaceable.

## REMOVAL

1. Disconnect power to the machine.
2. Remove the inner door panel.
3. Remove the metal reinforcement strip.
4. Remove control panel barrier covering components.
5. Disconnect wiring to electrical components and remove components.
6. Remove indicator lights from their lenses by sliding body of the light assembly away until it disengages from lens. Remove lens from front of facia.
7. Bend up retainer tabs which hold facia to control console.
8. Carefully separate facia from console by pushing tabs through slots.

**CAUTION:** *Facia is susceptible to damage during reinstallation.*

---

## DOOR LATCH STRIKE

The door latch serves as a mechanical actuator for door switch operation and provides door tension for proper door seal.

Adjusting Door Strike

1. Mark "underside" of the door strike prior to adjustment. This will provide a guide to make accurate "in" or "out" adjustments.
2. Loosen hex screw securing strike to tub. Slide strike "in" to increase door closure force and tighten door seal. Moving strike "out" will decrease closure force.

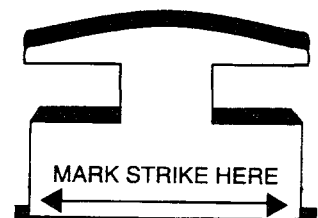

Figure 4-10

---

## DOOR GASKET

The door gasket provides a seal between the door and the tub.

### Removal

1. Open door.
2. From the lower left corner, pull gasket up and out of tub recess. Note position of the gasket in lower right corner of door.

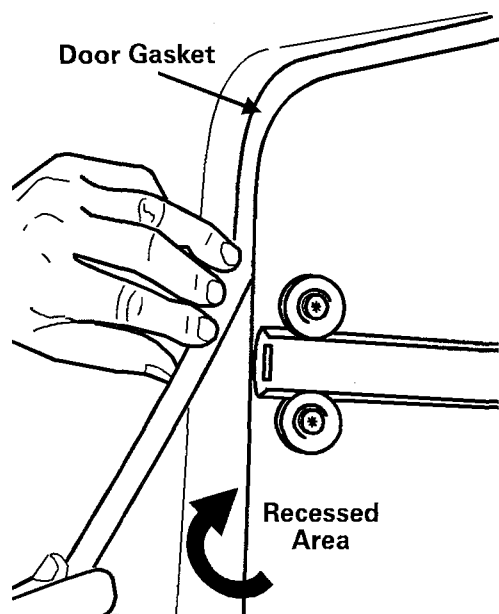

Figure 4-11

### Replacement

1. To ease installation, wet gasket with water.
2. Starting in the lower right corner, form a bend 1" from gasket end and place in corner.
3. Gently work gasket into the recess of tub up the right side.
4. With other end, place gasket flush with the tub in lower left corner.
5. Gently work gasket in to the recess of the tub, up the left side, and across the top.

6. Check for proper door latch adjustment to ensure proper door sealing.

---

## DOOR HINGES

The door hinge screws are used to adjust complete door assembly to dishwasher tub front, and proper alignment with door gasket.

### Adjustment

1. Remove front panel from door.
2. Loosen 3 hinge screws on each side of door assembly. Latch door.
3. Pull bottom of door assembly away from tub as far as it will go.

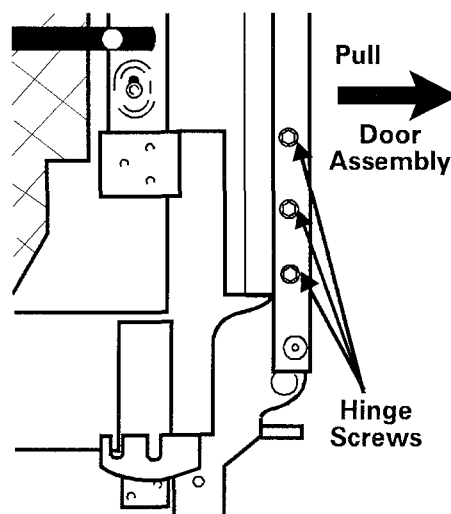

Figure 4-12

4. Tighten hinge screws very tight (75 in. lb.).
5. Adjust door latch strike for proper door closure force. Check door liner placement with respect to door gasket. The liner needs to be centered on the gasket. Using chalk or talcum powder on liner, close door then reopen. Imprint of liner meeting the gasket will be left. Make necessary adjustments to the door assembly to center the door.

---

## HINGE SPRINGS

The hinge springs provide a counter balance to the weight of the door.

The door spring is inserted through the offset portion of the link, with offset of the link positioned toward the dishwasher. The other end of link is mounted into appropriate slot of the hinge.

Timer Models - Left spring link is mounted in rear notch, and right spring link is mounted in front notch of door hinge.

Microprocessor Models - Both spring links are mounted in the front notch of door hinge.

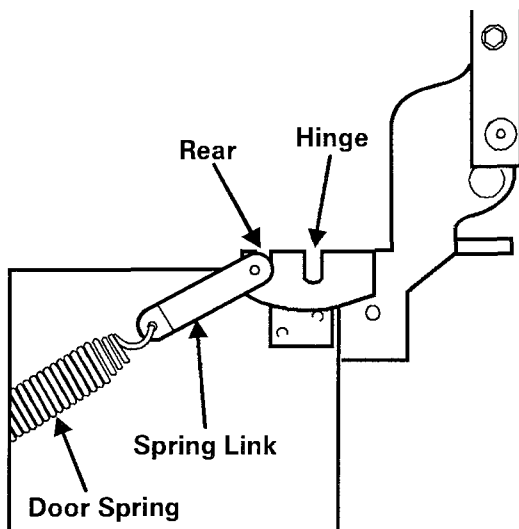

Figure 4-13

The bottom end of spring is hooked in the hole of the adjustment bracket.

**NOTE:** *Always point spring hooks toward the dishwasher.*

Door spring adjustment brackets are located behind the toe panel, on the right and left side. The brackets stretch the springs by sliding forward and backward along the dishwasher tub support. To change spring tension, use 1/4" hex nut driver. Adjust springs equally. Failure to do so may lead to a "twisted door" condition.

**Increase Spring Tension:** Turn adjustment screw in a clockwise direction.

**Decrease Spring Tension:** Turn adjustment screw in a counter clockwise direction.

---

## Proper Door Tension

The proper setting is when the door will remain open to a minimum of 6" (when measured from tub flange to top of the door). When opened slightly further, the door will fall at a slow rate and come to rest horizontally or slightly higher. The door should not fall rapidly so as to "bounce" when fully opened.

Heavy decorator panels may make it necessary to relocate door spring link to rear notch on both hinges. This will enhance spring tension. Check door for proper tension. An Auxiliary Door Spring Kit (12001228) is available through any authorized Maytag Customer Service parts distributor.

---

## UPPER SPRAY ARM

### Removal

1. Unscrew spin nut above spray arm from upper spray hose.

### Replacement

1. Screw spin nut onto upper spray hose.

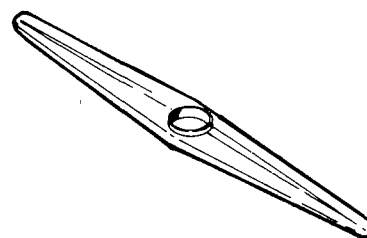

Figure 4-14

---

## UPPER SPRAY ARM HOSE

Water is supplied to upper spray arm through this hose via the pump assembly. The hose attaches to pump assembly, runs vertically up right side, then to center of the dishwasher tub and enters through the hole above the upper spray arm. The upper spray arm hose is sealed to tub top with a sprayer that is compressed to the tub by the upper spray arm spin nut.

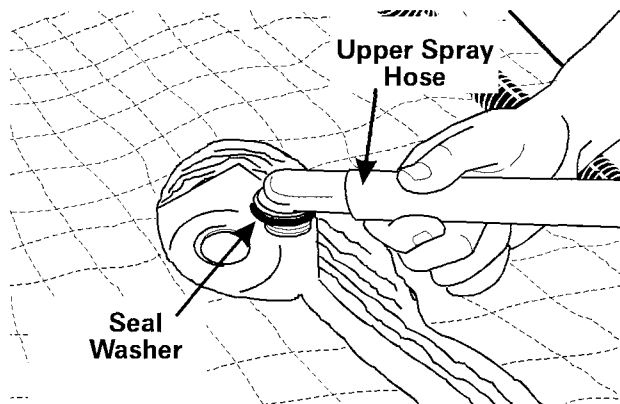

Figure 4-15

### Removal

1. Disconnect power supply, water supply and drain line.
2. *Built-in models:* Remove dishwasher from under the cabinet.  
  
*Portable models:* Remove the top and cabinet. (See section - *Portable Models*).
3. Remove access and toe panels.
4. Loosen hose clamp securing upper spray arm hose to pump assembly and pull off.  
**NOTE:** *Water may be contained in the hose.*
5. Remove upper spray arm spin nut.
6. Lift hose up and remove.

When reinstalling the upper spray arm hose, properly position seal between tub top and hose. Tighten with upper spray arm spin nut.

Reconnect hose to pump assembly. Ensure that hose is fully seated on pump assembly outlet and clamp is retightened.

---

## FLOAT ASSEMBLY

The float assembly controls the amount of water fill.

The float switch is wired in series with the water valve. When the float switch **OPENS**, the electrical circuit to the water valve is opened, causing the water valve to shut off.

A normal fill is when water makes contact with heating element in bottom of dishwasher.

The float assembly consists of a float, float switch, actuator lever and bracket.

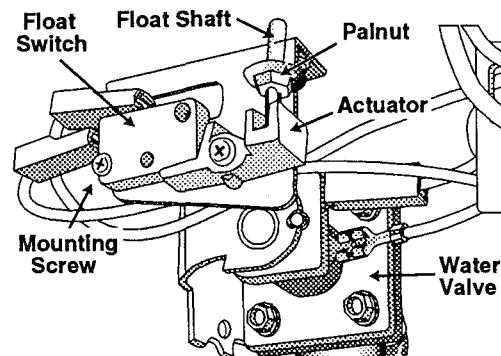

### Removal

1. Disconnect power to the machine.
2. Remove access and toe panels.
3. Locate float assembly in left corner. Remove palnut from float shaft.

**CAUTION:** *If float shaft twists off, replace float.*

4. Lift float straight up from float guide.
5. To remove actuator, remove mounting screw from bracket.
6. To remove float switch, remove mounting screw from bracket, then remove wire leads from switch.
7. To remove bracket, remove mounting screws from tub support base.

#### To Check Float Switch

1. Perform continuity check of switch across wire terminals.

*Closed* - Actuator of switch depressed.

*Open* - Actuator of switch released.

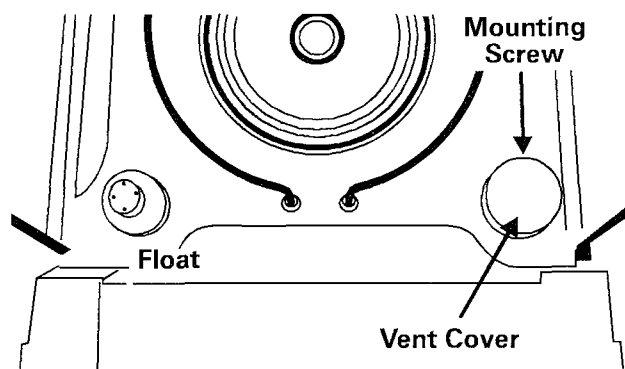

Figure 4-17

#### VENT COVER

The vent cover is located in the lower right front corner of the dishwasher tub.

#### Removal

1. Open door and remove lower rack.
2. Remove Torx screw securing cover. Lift cover from tub basin.

#### SUDS RESERVOIR/ CONVECTION VENT INLET

The suds reservoir is located below the vent cover and housed below the tub. The purpose of this component is two fold. One is to collect excess suds generated during wash cycle. The second is to provide an air inlet for convection drying during the dry cycle.

#### Removal

1. Disconnect power to the machine.
2. Remove access and toe panels.
3. Remove vent cover from inside the tub.
4. Lift vent tube vertically and remove.
5. Remove mounting screw in front of suds reservoir.
6. Carefully lower front of suds reservoir and slightly pull toward front of dishwasher. A retaining tab on the reservoir fits into slot in top of tub support.

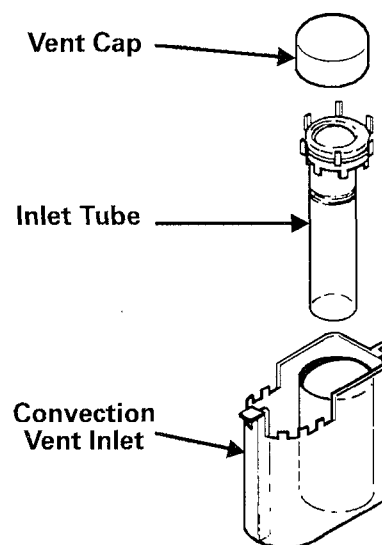

Figure 4-18

---

## START RELAY

Location of the start relay is in the access panel area on the front right side of the tub support ceiling. The relay is mounted to a bracket with a screw.

The start relay is a mechanism used to provide a direct electrical path to the start winding in the motor. This allows the motor to start. Once the motor reaches operating speed, current is reduced. This reduction in current causes a drop in magnetic field of the relay coil, mechanism drops down and switch then **OPENS**, taking out start windings in circuit.

**NOTE:** *The relay must be mounted in an upright vertical position.*

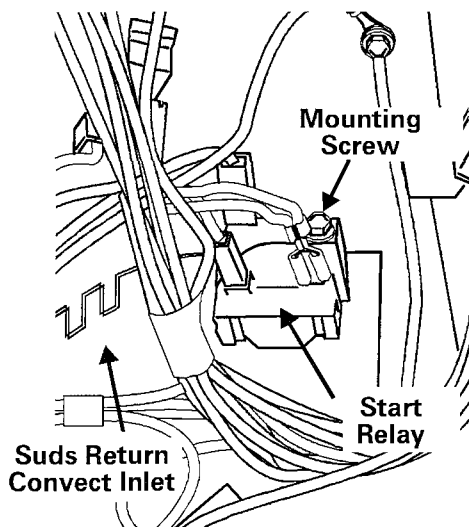

Figure 4-19

---

## START RELAY CHECKS

1. Disconnect power to the machine.
2. Remove relay wiring and mounting screw.
3. Hold relay in upright position and check continuity across yellow and white terminals. Continuity should be present. If not, replace relay.

4. Rotate relay upside down and check continuity across red and yellow, then red and white. Continuity should be present across both sets of terminals. If not, replace relay.

---

## HEATING ELEMENT

The purpose of the heating element is to provide heat during the dry cycle and increase water temperature during portions of the wash cycle when certain options are selected.

The element is dual wattage. During wash cycles, it is rated at 860 watts. During the dry portion of the cycle, it is rated at 650 watts. Increased wattage is possible because of water flowing across the element sheath.

### To Check Heating Element

1. Disconnect power to the machine.
2. Remove access and toe panels.
3. Locate element terminals, remove wires, perform continuity check across terminals.
4. The resistance of the element should be approximately 22 ohms. If OPEN, replace element.
5. Perform continuity check from each terminal to the element sheath. NO continuity should be present. If continuity is present, replace the element.

### Removal

1. Disconnect power to the machine.
2. Remove access and toe panels.
3. Locate element terminals, remove wires.
4. Remove mounting nuts securing heating element to tub.

5. Release heating element from two rear supports. To release, the top end of the bracket must be loosened from tub. Push element back.
6. Lift element out of tub.

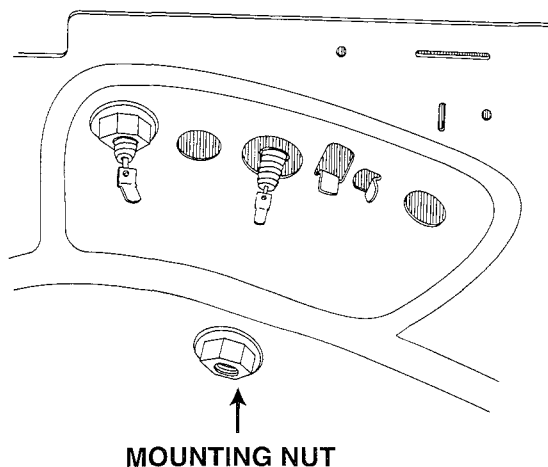

Figure 4-20

**NOTE:** Before reinstalling heating element, examine condition of O-ring seals that are located between element leads and tub basin. Replace if needed. Failure of seal will result in a water leak and possible floor damage.

### Wattage Checks

To verify wattage of the element, take an amperage reading at the blue wire of the heating element. Multiply the amperage reading by voltage at the dishwasher ( $\text{Amps} \times \text{Volts} = \text{Watts}$ ).

Normal element amperage during the dry portion of the cycle is 5.0 to 5.5 amps. When used during a wash cycle, normal amperage is 7.0 to 7.5 amps.

## THERMOSTATS

Two types of thermostats are used in the dishwasher, a boost thermostat and a limit thermostat.

The Boost thermostat is used to sense water temperature when certain cycles or options are selected (Refer to Cycles & Options section). It is mounted to the pump housing on left side. The thermostat has 3/16" terminals and has a normally OPEN position.

The other thermostat is a Limit Thermostat and is used as a protective device to sense overheating of the heating element. It is located in the access panel area, mounted to the ceiling of the tub support, and to the right of the heating element terminals. This thermostat has 1/4" terminals and has a normally CLOSED position.

**NOTE:** Refer to section labeled *GENERAL INFORMATION* for specifications on thermostats.

### Removal

1. Disconnect power to the machine.
2. Remove access and toe panels.
3. Pull out on spring tab to release thermostat and bracket from slots in tub support ceiling.
4. Remove wires from thermostat.

**NOTE:** When reinstalling, proper location and wiring of thermostat(s) is critical.



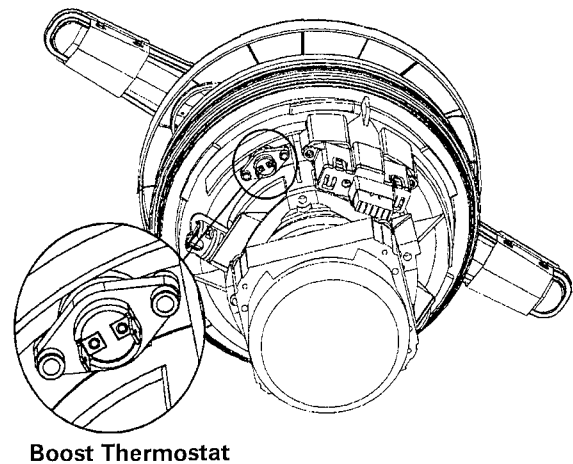
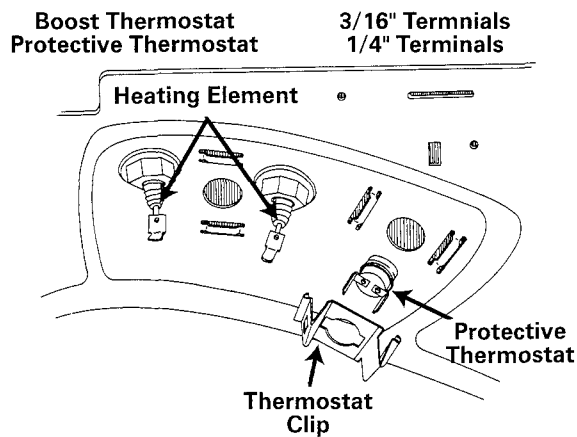

Figure 4-21

## WATER VALVE

The valve is located in the access panel area, mounted to the left side of the tub support. Inlet water supply to the valve is directly below the valve.

**NOTE:** Turn off water supply to the dishwasher before servicing this component.

The valve is designed to operate at water pressures of 15 - 120 psi. **NOTE:** Low water pressure will affect the ability of the water valve to properly fill tub in the required amount of time.

Incoming water temperature should be a minimum of 120 degrees F. However, a higher water temperature will enhance washing and drying results.

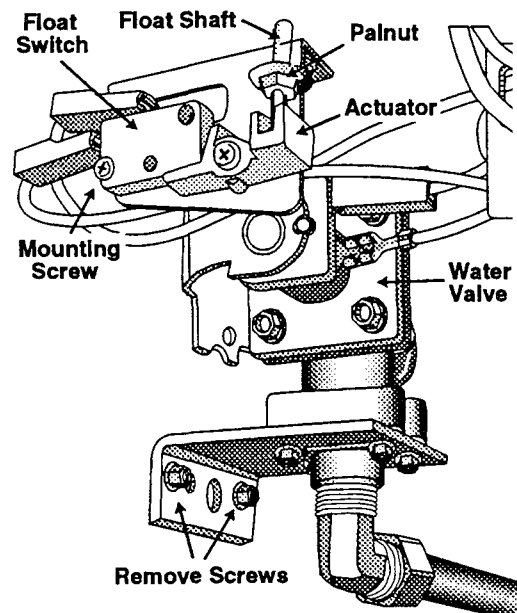

Figure 4-22

### Removal

1. Disconnect power to the machine.
2. Remove access and toe panels.
3. Turn off water supply to the dishwasher
4. Remove wires from valve solenoid.
5. Remove screws securing water valve to tub support.
6. Disconnect injector hose at valve outlet.

### Checking Valve Operation

#### No Fill

1. Disconnect power to the machine.
2. Remove access and toe panels.
3. Remove wires from valve solenoid.
4. Perform continuity check across terminals of solenoid. If NO continuity is present, replace water valve.

*Alternate Test:* Use motor test cord hooked directly to the valve solenoid. Turn water supply on and plug in test cord. If NO water is present, replace water valve.

#### Overfill

If water valve allows water to flow without power to valve solenoid, replace the water valve.

**NOTE:** *The water valve is a non-repairable component. The only servicing required is to clean the inlet screen if needed.*

---

#### Inlet Screen

Sediment on the inlet screen can hinder water flow through the water valve within the required length of time for fill.

#### Cleaning

1. Disconnect power to the machine.
2. Remove water valve from the dishwasher (See Water Valve Removal).
3. Remove 4 screws securing valve body to water inlet mounting bracket.

**NOTE:** When reinstalling, make sure to reattach the ground wire to the mounting bracket.

4. Clean screen.

---

#### WATER INJECTOR

The water injector is located on the left side of the tub, and mounted to the exterior of tub. Removal of water injector requires the removal of the dishwasher from under the counter or removal of cabinet on portable models.

#### Removal

1. Disconnect power to the machine.

2. Carefully remove insulation from left side of the tub.
3. Unlock injector hose from recess on the tub.
4. Grasp upper portion of the injector. Pull and rotate the injector clockwise to a two o'clock position. This type of movement allows the injector to pass over a "ramp" protruding from the tub wall.
5. At the two o'clock position, pull the injector out.

#### Replacement

1. Examine the seal washer between the injector and the tub for damage.
2. Position injector at two o'clock and rotate counterclockwise while pressing inward. The injector will slide up the ramp, then snap into position.

---

#### SPRAY TOWER ASSEMBLY

Located in the center of the lower rack. Water is injected into the spray tower by the pump assembly through the jump up nozzle located in the center of the lower spray arm support.

The water enters the bottom of the spray tower and travels up the interior ribs to the spray diverter on top of the spray tower. The spray diverter directs water to the upper rack. The hole in the top of the diverter covers the center of the upper rack and two additional holes in the side of the spray tower direct water to the silverware basket.

## Removal

1. Remove lower rack from dishwasher.
2. Grasp spray tower and rotate 30 degrees counterclockwise.

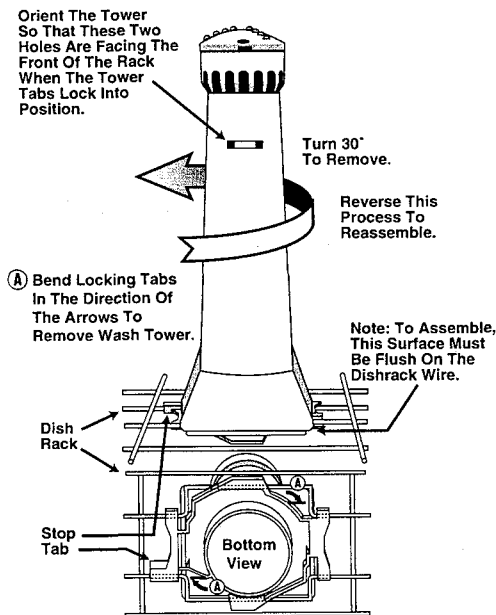

Figure 4-23

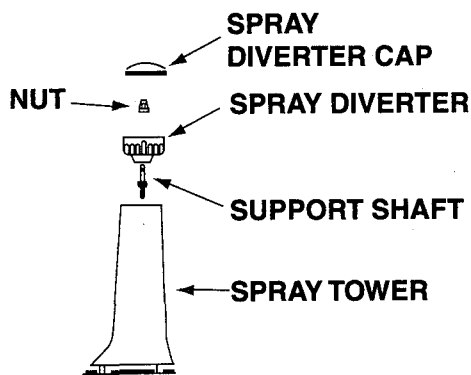

Figure 4-24

## Disassembly

1. Unsnap diverter cap from spray diverter.
2. Unscrew nylon nut securing spray diverter to the spray tower support shaft.

## Upper Rack Removal

To remove upper rack, remove rack rail retainer. Use the handle of a screwdriver and press handle on the outside edge of the retainer. Then, roll inward, toward rack, while pressing on the retainer. This will disengage the locking tabs from the rail. Slide the retainer off of the rail. Repeat this procedure for the other rail. Slide the rack out of rack rails.

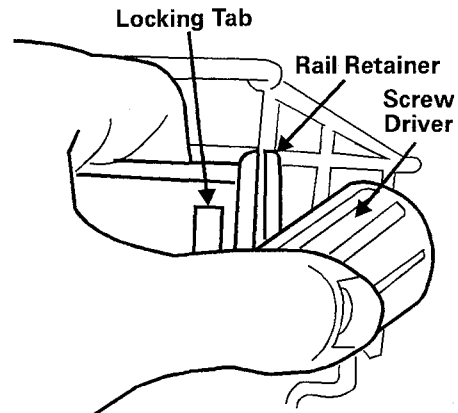

Figure 4-25

## Rack Rollers - Tub

To remove, partially unscrew the roller mounting screw. Use end of torx driver against the side wall of the roller and press the roller back against the tub wall. This will disengage the steel washer from the shoulder on the mounting screw behind the roller. Finish removing the roller mounting screw.

**NOTE:** Use caution when removing the screw so as not to lose the steel washer behind the roller.

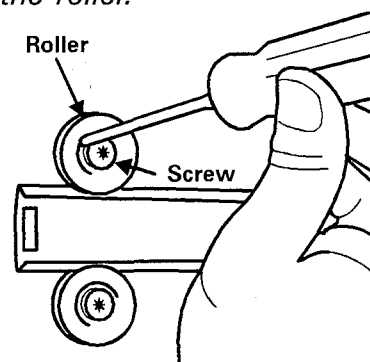

Figure 4-26

---

## POWER MODULE

The power module consists of a pump and electrical motor combined to provide drain and recirculating functions for the dishwasher cycles. If a failure is suspected inside the pump assembly, individual parts in the pump may be replaced. However, if housing or motor need replacing, a complete motor & housing assembly must be replaced.

To repair pump portion of the module, it is NOT NECESSARY to remove it from the dishwasher.

### Disassembly

1. Unscrew spray arm cap.
2. Remove spray arm.
3. Remove jump up nozzle.
4. Remove pump cover (coarse strainer) by removing 6 torx screws securing it to the pump housing.
5. Remove 2 split ring seals.
6. Remove primary micromesh filter.
7. Remove back spray arm from spray arm support.
8. Unscrew nylon nut located in the center of the spray arm support. Remove spray arm support.
9. Unscrew 3, 5/16", screws securing the upper discharge housing. Remove the upper discharge housing.
10. Remove 5/16" screw securing impeller. Remove impeller.
11. Remove suction plate.
12. Remove green check ball.
13. Remove filter support.

14. Remove stainless steel cutter disc.
15. Remove 3 torx screws securing the drain cover (chopper Plate) to the housing. Remove drain cover.
16. Remove drain impeller "O" ring and drain impeller.
17. Remove pump housing seal.

To reassemble pump module, reverse disassembly procedure. When reassembling pump, care needs to be taken on placement of some parts.

When installing pump housing seal, the seal must be fully seated into pump housing.

After installing drain impeller, install "O" ring.

Before installing suction plate, insert green check ball.

After installing recirculating impeller, install screw, making sure the "O" ring is still on the screw.

When installing the pump cover, and before installing the screws, insert the split ring seals into the center opening of the filter. While securing the with screws, gently spin spray arm support to verify that the filter and the seals are not binding the spray arm support.

PUMP ASSEMBLY

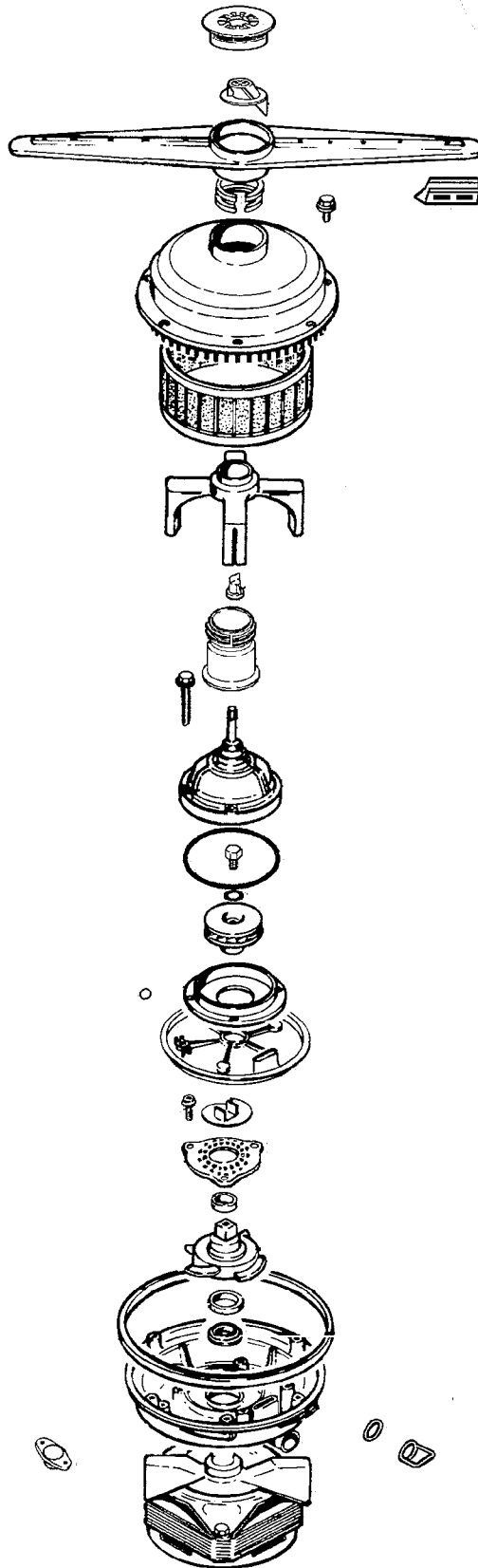

## Removal

1. Disconnect power to the machine.
2. Remove access and toe panels.
3. Loosen drain hose clamp on the left side of the pump. Disconnect the hose from the housing.
4. Loosen hose clamp for upper spray arm hose on the right side of the pump module. Disconnect the hose from the housing.
5. Disconnect the motor wire harness from the main wire harness by pulling the connector apart.

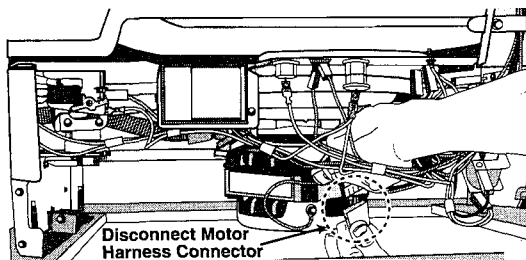

Figure 4-27

6. Remove hex screw securing the GREEN ground wire to the motor frame.

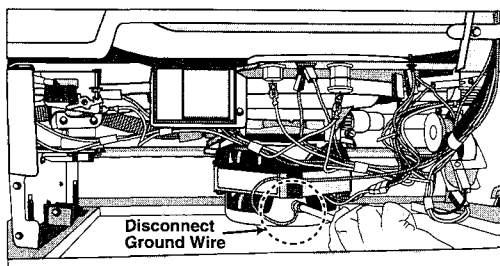

Figure 4-28

7. While pushing handle toward the rear of the dishwasher into a 11 o'clock position, grasp clamp ring handle and pull down.
8. Lift pump module out from inside the dishwasher tub.

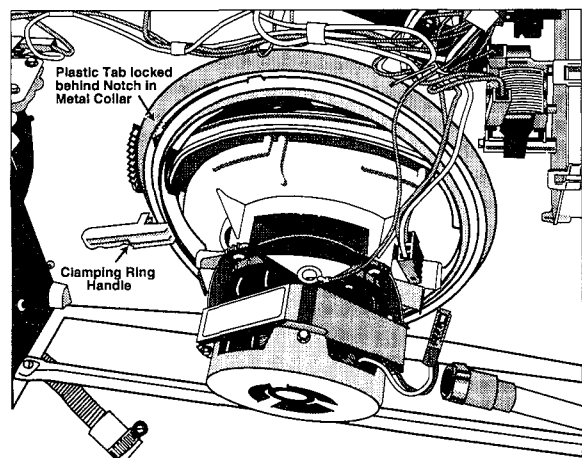

Figure 4-29

## Replacement

1. Check proper engagement of gasket to pump housing prior to installing pump module in dishwasher. With gasket in place on outer lip of housing, roll outside edge of gasket upward while pressing toward the center of the pump module. Continue around the perimeter of the housing.
2. Check position of clamping ring. Move ring forward between tub and tub support to allow alignment rib on the housing to clear. Position tab on the rib to align with detent on support ceiling.

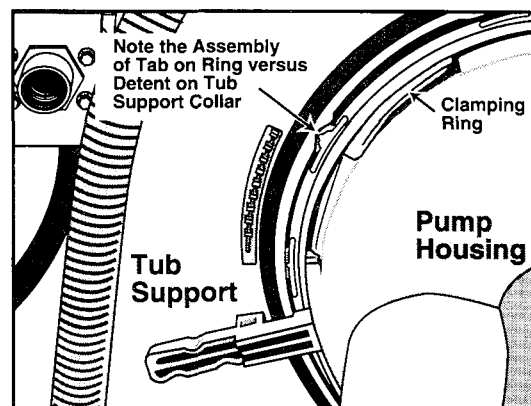

Figure 4-30

3. Lower pump module into the tub opening with alignment rib on the pump housing aligned with the cutout in the tub floor.

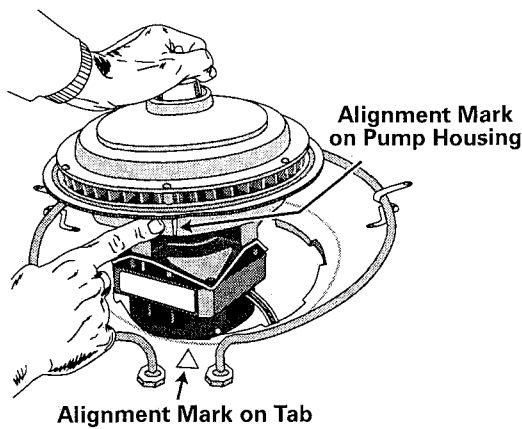

Figure 4-31

4. With pump module lowered into the tub, grasp the top of the pump module, checking for firm positioning into the tub.
5. Check position of holding tabs of the clamp ring, located between the tub support and tub. Sometimes the clamp ring can be dislodged, making it difficult to lock pump module into position.
6. Grasp the clamp ring handle and carefully pull handle towards the front to engage exposed teeth on the ceiling of the tub support.
7. Reconnect the wire harness, ground wire and hoses. Tighten hose clamps and reinstall the toe and access panels.

---

## PORTABLE DISHWASHERS

---

### Wood Top

Portable dishwashers will have a top made of wood composition core with a Formica™ laminated top and sides. Use of Formica™ has a number of advantages such as: superior moisture resistance, greater stain resistance, durability and very low maintenance.

### Removal

1. Remove the two screws securing the top to the mounting flanges positioned under the top in front of the tub.
2. Carefully slide top forward to disengage spacer washers from slots in the rear of the cabinet flange.

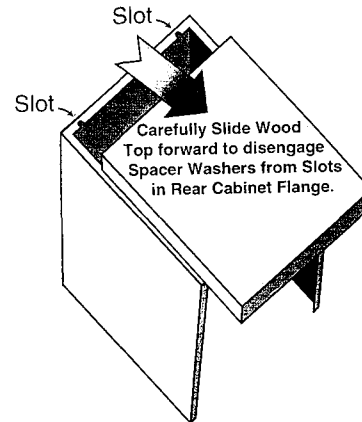

Figure 4-32

---

### Cabinet

#### Removal

1. Remove wood top.
2. Remove access and toe panels.
3. Remove 4 screws securing the front flange of cabinet to the tub.
4. Remove the front and rear cabinet screws that secure the cabinet to the tub and base supports.
5. Disconnect power cord from the terminal box. Disconnect the fill hose from the water valve and the drain hose from the pump module.
6. Remove the wire tie securing the drain and fill hoses to "U" shaped bracket on the rear wall of the cabinet.
7. Carefully spread the front cabinet sides for clearance around the tub flange.

**CAUTION:** *Do not bend excessively as this may cause cabinet damage in the rear corners.*

8. Pull cabinet away from the dishwasher.
9. Remove 5 palnuts securing the retainer for the faucet coupler on the back of the cabinet.

---

## Casters

### Removal

1. Remove access and toe panels.
2. Lift or block the dishwasher up to access the casters.
3. With a screwdriver, pry caster from the socket.

---

## Faucet Coupler

The faucet coupler provides a means for filling and draining the portable dishwasher. It connects to a special adapter which in turn is connected to a faucet at a sink. When the dishwasher is not in use, the faucet coupler is stored in a retainer on the rear of the dishwasher cabinet (*Figure 4-33*).

### Removal

1. Remove wood top.
2. Remove access and toe panels.
3. Disconnect the power cord from the terminal box. Disconnect the fill hose from the water valve and the drain hose from the pump module.
4. Remove the wire tie securing the drain and fill hoses to "U" shaped bracket on rear wall of cabinet.

**NOTE:** *Repair of faucet coupler can be done without removing the hose assembly from the dishwasher.*

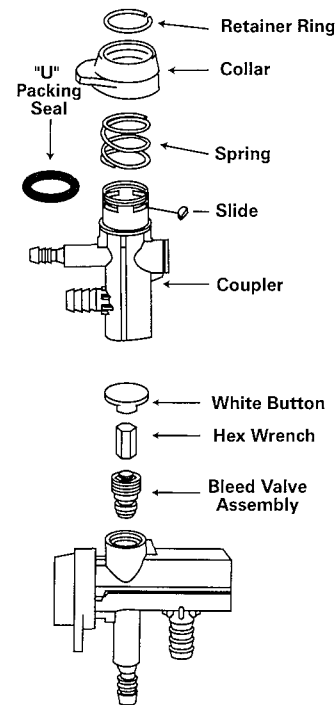

*Figure 4-33*

---

## Retainer - Faucet Coupler

The retainer provides a storage area for the coupler and power cord when dishwasher is not in use.

### Removal

1. Remove cabinet.
2. Remove 5 palnuts securing the retainer to the rear cabinet wall.

---

## WATER DEFLECTORS

The water deflectors are located in the lower front corners of the dishwasher tub. They allow water to be deflected away from the corners, eliminating the "surging" effect of water behind the inner door.

### Removal

Open dishwasher door completely. Grasp deflector and lift straight up. To reinstall, slide deflector down, ensuring deflector slides on pins molded into tub.



---

## SECTION 5. GENERAL INFORMATION

---

### SPECIFICATIONS

DIMENSIONS	Built-in Models	24" W x 33 <sup>3</sup> / <sub>4</sub> " - 35" H x 22 <sup>3</sup> / <sub>4</sub> D (61cm W x 85.7cm - 88.9cm H x
57.7cm D)		
D)	Portable	28 <sup>1</sup> / <sub>4</sub> " W x 33 <sup>3</sup> / <sub>4</sub> " H x 24 <sup>1</sup> / <sub>4</sub> " D (71.7cm W x 85.7cm H x 61.6cm
ELECTRICAL SUPPLY	120 Volts AC/60HZ. All models require 15 amp fused circuit. Portable models require a 3 prong properly grounded outlet. Portable models - 6 <sup>1</sup> / <sub>2</sub> ' (198.1cm) power cord furnished.	
WATER SUPPLY	Water supply line must be 3/8" (1.0cm) OD or 1/2" (1.3cm) OD copper tubing. Water pressure 20 - 120 P.S.I. (1.06 - 8.44 kg/cm). Water temperature should be a minimum of 120° F (49° C) upon entry into dishwasher.	
DRAIN LINE (Built-in Models)	5/8" (1.6CM) ID X 7' (213.36cm) long corrugated drain hose, furnished. Drain line must be elevated at least 32" (81cm) above the floor.	
COUPLER ASSEMBLY (Portable Models)	3' (91.4cm) long, drain and fill hose. Both hoses attached to faucet coupler assembly, which attaches to a sink faucet.	
WEIGHT	PDB1600	87 lbs. (40kg)
	PDB2600	94 lbs. (43kg)
	PDB3600	80 lbs. (37kg)
	PDB4600	80 lbs. (37kg)
	PDC3600	187 lbs. (85kg)
	* All weights are approximate and subject to change.	
CUSTOM PANEL DIMENSIONS	Door Panel Insert	1/4" x 18 <sup>3</sup> / <sub>16</sub> " x 23 <sup>9</sup> / <sub>16</sub> " (.64cm x 46.2cm x 59.8cm)
	Access Panel Insert	1/4" x 5 <sup>5</sup> / <sub>8</sub> " x 23 <sup>11</sup> / <sub>16</sub> " (.64cm x 11.7cm x 60.2cm)

---

## COMPONENT INFORMATION

MOTOR/PUMP	Reversing 1/3 HP motor. 120V/60HZ, 6.5 amps, 3450 RPM. Two-stage pump for circulation and draining.
WATER VALVE	120V/60HZ, 7 Watts, 1.25 ± .15 GPM at 20 - 120 P.S.I.
HEATING ELEMENT	120V/60HZ, 650 Watts ± 5% in air, 830 Watts ± 5 % in water.
LIMITING THERMOSTAT	SPST, ¼" terminal switch. Close at 139° ± 7°F (59.4° ± -13.9° C). Open at 154° ± 4°F (67.8° ± -15.6°C).
BOOST THERMOSTAT (Pump Mounted)	SPST, 3/16" terminal switch. Close at 135° ± 5°F (57.2° ± 15° C). Open at 120° ± 5° (48.8° ± -15°C).
WAX MOTOR	Detergent/Rinse Aid - 120V incremental duty, ¼" actuation stroke within 90 seconds.

# ELECTRICAL SCHEMATICS - PDB1600 & PDB2600

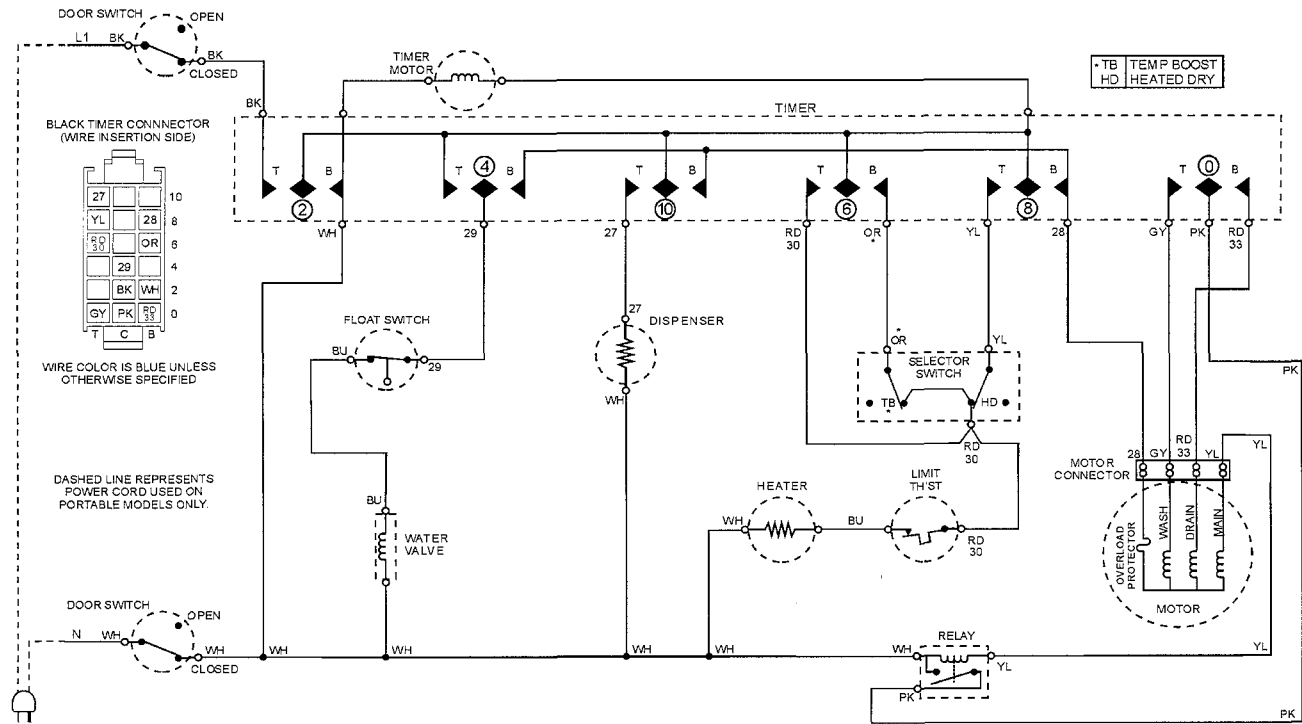
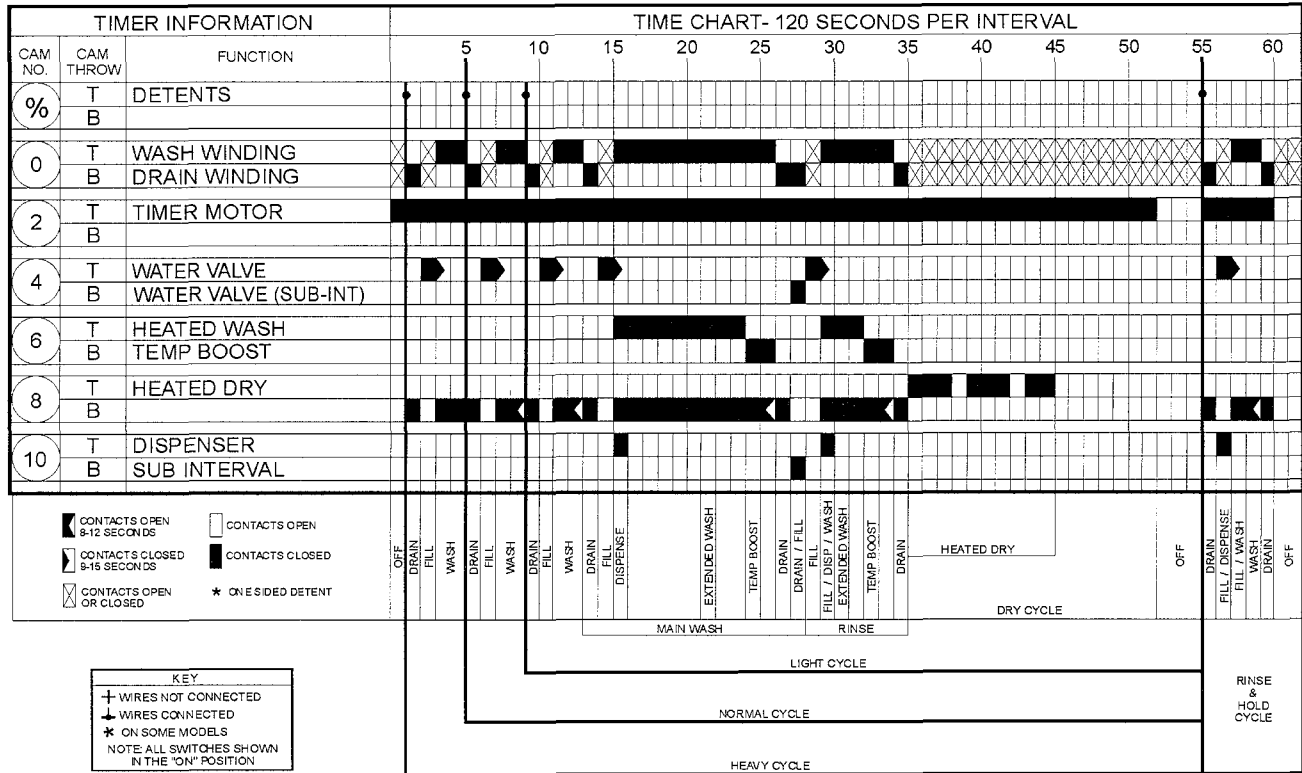

6 915983 A

# ELECTRICAL SCHEMATICS - PDB3600 & PDC3600

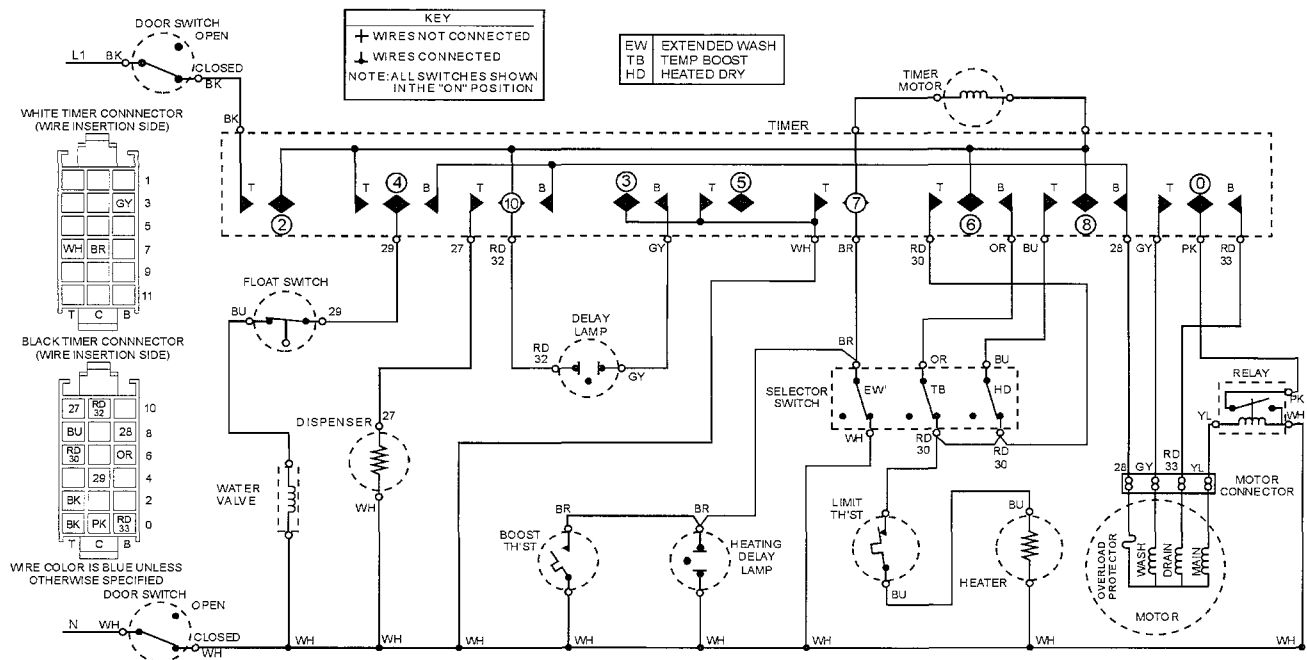
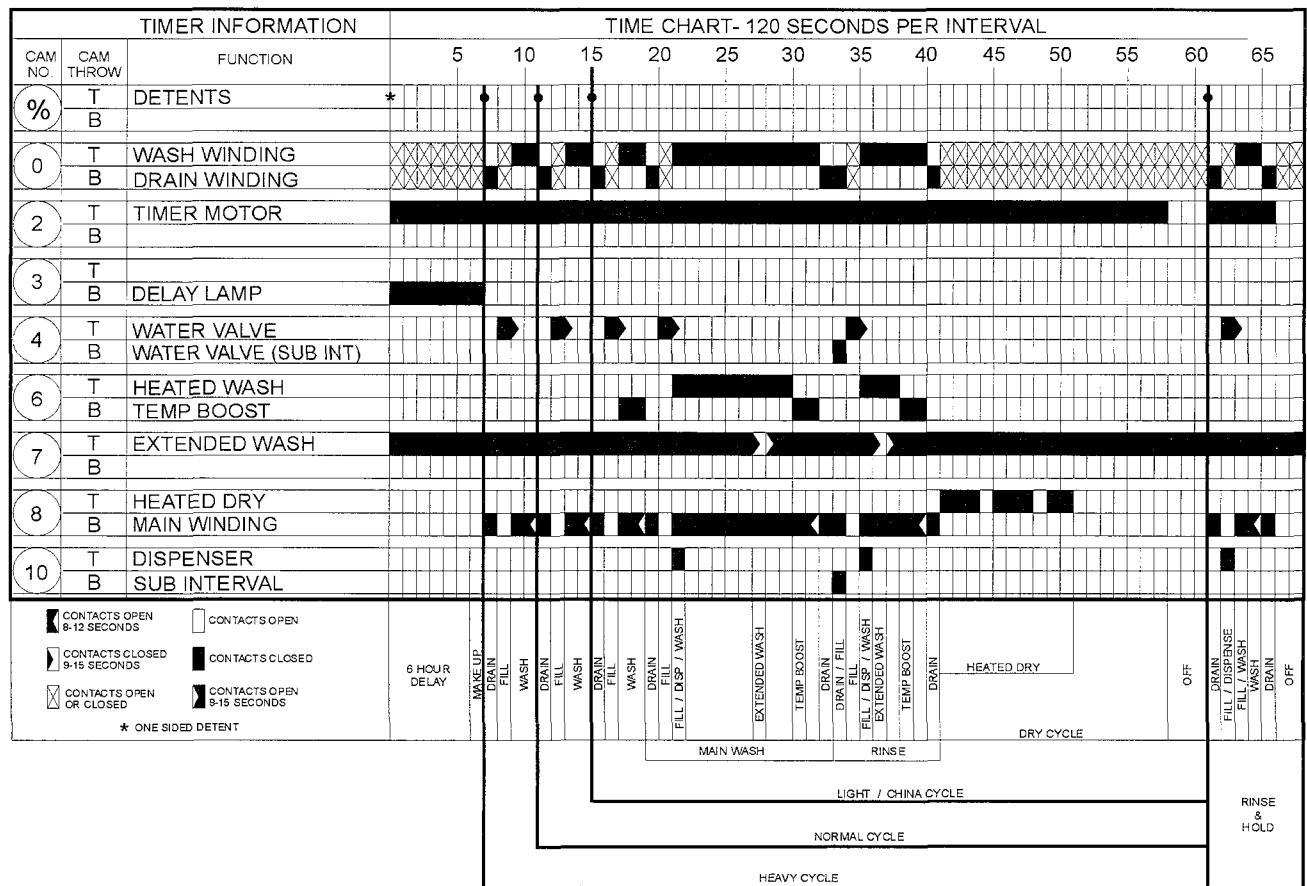

6 915984 B

## ELECTRICAL SCHEMATIC

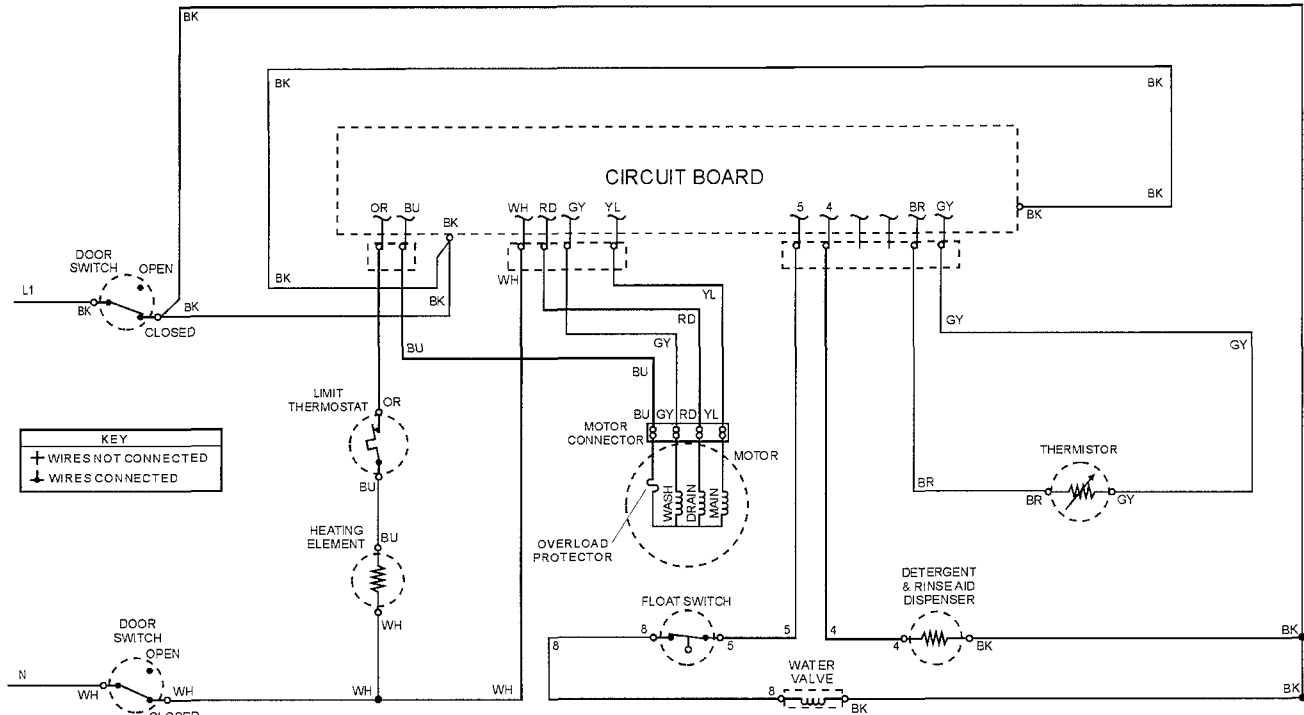

### Component Information

Motor & Pump	Reversing 1/3 HP motor. 120V/60HZ, 6.5 amps, 3450 RPM. Two stage pump for circulation and draining. Main wattage 420 watts, wash wattage 1180 watts.
Water Valve	120V/60HZ, 7 watts, 125 ± .15 GPM at 20 - 120 P.S.I.
Heating Element	120V/60HZ, 650 watts ± 5% in air, 830 watts ± 5% in cold water.
Limiting Thermostat	SPST ¼" terminal switch. Close at 139° ± 7°F (59.4° ± 3.9°C). Open at 154° ± 4°F (67.8° ± 2.3°C).
Thermistor	Resistance and tolerance: 50kΩ ± 6% at 77°F (25°C) and 12.4kΩ ± 3% at 140°F (60°C).
Wax Motor	Detergent/Rinse Aid - 120V incremental duty, ¼" actuation stroke within 90 seconds.

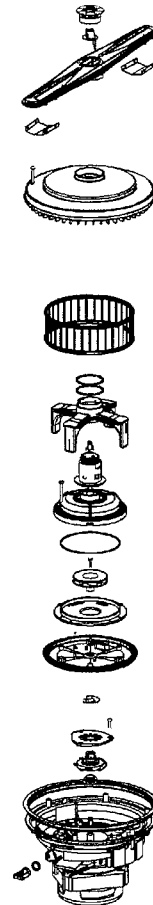

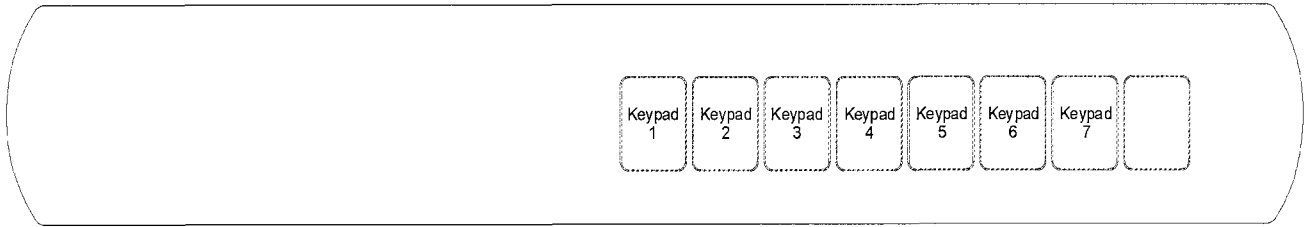

### Automatic Function Test

An Automatic Function Test may be started by pressing the keys in one of the following sequences within 10 seconds:

Keypad 2  
Keypad 1  
Keypad 2  
Keypad 3  
Keypad 4  
Keypad 5  
Keypad 6  
Keypad 7  
Keypad 1

SECONDS	FUNCTIONS
20	Water Valve (this is a partial fill)
5	Pause
120	Motor (wash), Heater energized, Dispenser Wax Motor (det. cup) energized
6	Motor pause
5	Pause
50	Motor (drain)

The Automatic Function Test will not repeat. The **Wash** LED will **Flash** during the test mode. Indicator lights will illuminate one at a time in a progressive order until all are lit. All LED's (except **Wash**) will then go off simultaneously and the process will repeat throughout the duration of the test. If the dishwasher door is opened during the test, the test sequence will pause, and resume when the door is closed (must be closed within 30 seconds).

To cancel test, press the **Drain / Off** keypad.

The control has been designed to test the Thermistor and Motor. During the AFT, if a fault has been detected, the test will abort and 2 LED's will begin to **Flash**. The **Clean** LED and one of the following:

**Thermistor** - open circuit - Keypad 5 LED

**Thermistor** - shorted - Keypad 4 LED

**Motor** - high current - Keypad 3 LED

**Motor** - low current - Keypad 2 LED

A **Memory/Software Check** will occur immediately after the control is powered up. If a failure is detected, the **Clean** and **Keypad 7** LED's will **Flash** and the test will abort.

### Manual Function Test

A Manual Function Test may be started by pressing the keys in the following sequence within 10 seconds:

Keypad 2  
Keypad 1  
Keypad 2  
Keypad 3  
Keypad 4  
Keypad 5  
Keypad 6  
Keypad 7  
Keypad 4

The **Dry** LED will **Flash** indicating manual test mode active. Specific keypads will turn on or off a component as follows:

Keypad 2	Motor circulate
Keypad 3	Water Valve
Keypad 4	Soap Dispenser (lid closed)
	Rinse Aid (lid open)
Keypad 6	Heating Element

When a component is activated by pressing a specific keypad, the LED above the keypad will be **On**.

The test will cancel 120 seconds after the last keypad is pressed.

To cancel test, press the **Drain / Off** keypad.

### Sales Floor Demo Mode

Depress **Rinse Only** keypad 5 times within 5 seconds. LED's will sequence at a 1 second rate as follows:

Clean  
Dry  
Wash  
Heating Delay  
2 HR  
4 HR  
6 HR  
Rinse Only  
Light Wash  
Normal Wash  
Heavy Wash  
Accu Temp  
Heated Dry  
Drain / Off

This mode will repeat. To cancel, depress the **Drain / Off** keypad twice.

### Diagnostic Tips

To check control LED's, enter **Sales Floor Demo Mode**. If control fails to perform as described, replace control.

To check control and components, enter **Automatic Function Test**. If control fails to perform sequence as described, and a fault is detected, determine failure as described in the **Automatic Function Test**. If a load component failure has been diagnosed, proceed to the **Manual Function Test**.

To check individual load components for proper operation, enter **Manual Function Test**. Follow test procedure as described. Repair or replace component as needed.

**Note:** The **High Current** or **Low Current** may be detected during a wash cycle selected by a consumer. If this happens, the control will go into a 10 minute auto restart mode.

6 915985 A

**MAYTAG**

---

Maytag Appliances Sales Company

Customer Service  
240 Edwards Street, S.E.  
Cleveland, Tennessee 37311