



Fast Track Troubleshooting

Models:

DMR57LFB/XAA
 DMR57LFS/XAA
 DMR57LFW/XAA
 DMR77LHB/XAA
 DMR77LHS/XAA
 DMR77LHW/XAA
 DMR78AHB/XAA
 DMR78AHS/XAA
 DMR78AHW/XAA

IMPORTANT SAFETY NOTICE – “For Technicians Only” This service data sheet is intended for use by persons having electrical, electronic, and mechanical experience and knowledge at a level generally considered acceptable in the appliance repair trade. Any attempt to repair a major appliance may result in personal injury and property damage. The manufacturer or seller cannot be responsible, nor assume any liability for injury or damage of any kind arising from the use of this data sheet.

Publication # tsDMR57 Creation Date 01/21/2010

Which Detergent Ingredients Give Best Dishwasher Performance

Detergent with a separate rinse additive in the dispenser gives better drying performance. For tough baked on soils an Enzyme detergent is better at hydration of the food soils. For staining such as tomato, coffee and tea, a detergent with a higher phosphate content and Chlorine bleach will work on the stains much better than an Enzyme based detergent.

Dead Dishwasher — Possible Bad Fuse

- Units with a fuse, if it blows there is very low A/C voltage at PCB L1 to N, L1 to Ground will read 120vac.
- Replace fuse and unit may work properly, usually a "weak fuse".
- Neutral is fused, use **caution** as L1 is hot, you will be “shocked” between L1 and Chassis.
- Later production the fuse is "**hidden**" in the wire harness.
- Newer production (May 2009 Serial *S5*) has **no fuse**. Dead unit, look for cause, if none, replace main PCB (new part #)

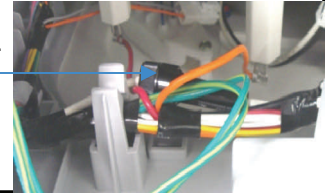

Dishwasher Cycle Chart — Condensation Dry System

Program	Drain	Pre-wash 1	Pre-wash 2	Pre-wash 3	Main wash	Rinse 1	Rinse 2	Rinse 3	Dry	Total Time
Normal	0:45	16:30	(16:30)	-	32:30:00	7:30	(7:30)	32:30:00	20	110~134
Heavy	0:45	17:30	17:30	17:30	46:30:00	7:30	7:30	46:30:00	20	181
Delicate	0:45	16:30	-	-	37:30:00	7:30	-	32:30:00	20	115
Rinse	0:45	-	-	-	-	9:30	-	-	-	11
Quick	0:45	5:30	-	-	11:30	7:30	-	12:30	-	38
Smart Auto	0:45	5:30 ~17:30	(17:30)	(17:30)	11:30 ~46:30	7:30	(7:30)	12:30 ~46:30	20	58~181
Program		Pre-wash 1,2,3			Main wash	Rinse 1,2		Rinse 3		
								No Sanitize	Sanitize	
Normal	-	-	-	-	120°F (49°C)	-	-	140°F (60°C)	162°F (72°C)	
Heavy	-	-	-	-	149°F (65°C)	-	-	158°F (70°C)	162°F (72°C)	
Delicate	-	-	-	-	113°F (45°C)	-	-	140°F (60°C)	162°F (72°C)	
Rinse	-	-	-	-	-	-	-	-	-	
Quick	-	-	-	-	113 ?F (45°C)	-	-	140°F (60°C)	162°F (72°C)	
Smart Auto	-	-	-	-	113~149? F (45~65°C)	-	-	140~158? F (60~70°C)	162°F (72°C)	

Wiring Diagram after 5-1-2009

DMR57 / 77 / 78

SCHEMATIC DIAGRAM

MODEL CLASSIFICATION

DMR57XXX

1. HALF SENSING.
HALF LOAD MOTOR DELETE

2. DOTTED LINE IS DMR78 (77) MODEL
AND SOLID LINE IS DMR57 MODEL

DMR78XXX (DMR77XXX)

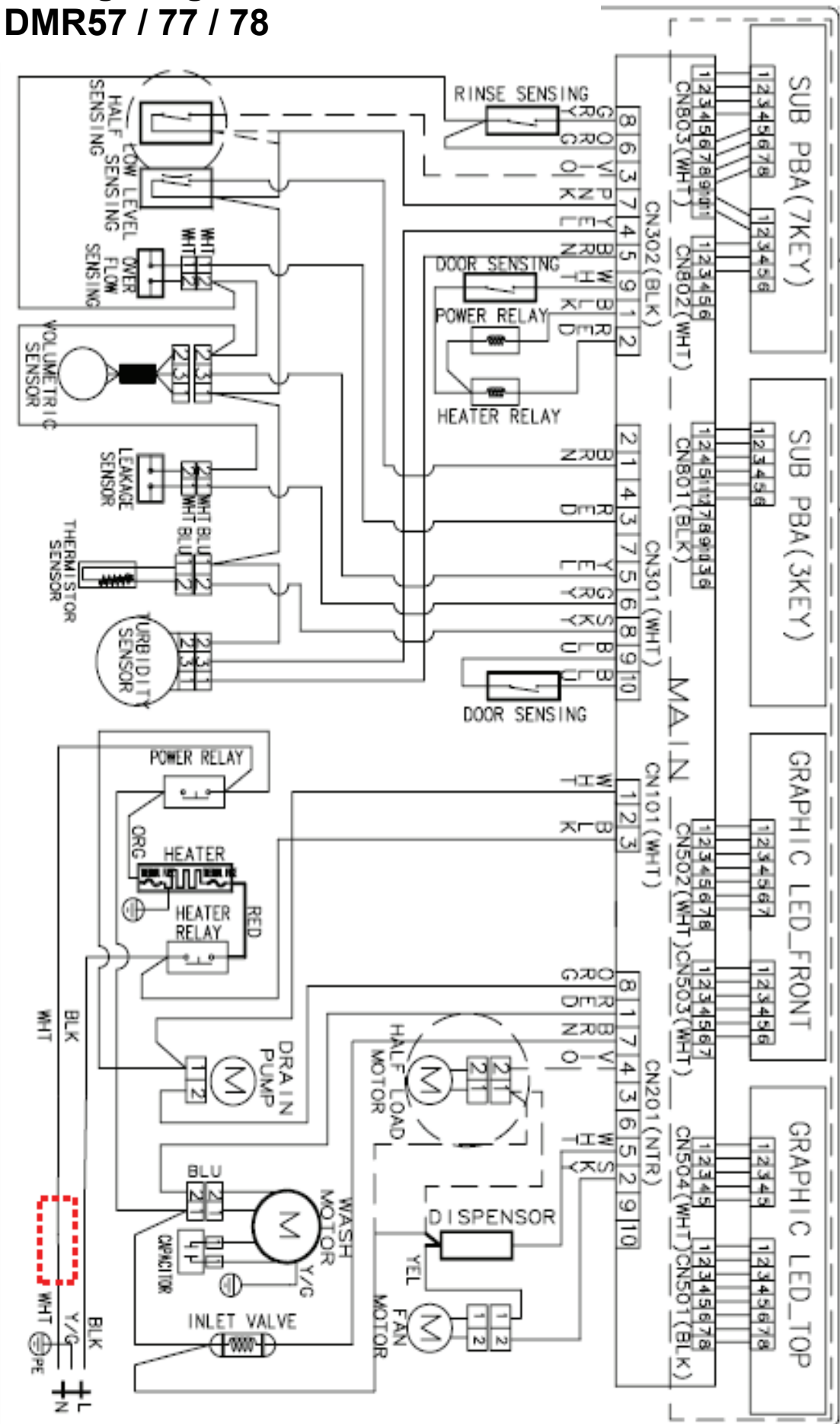

Wiring Diagram before 5-1-2009 DMR57

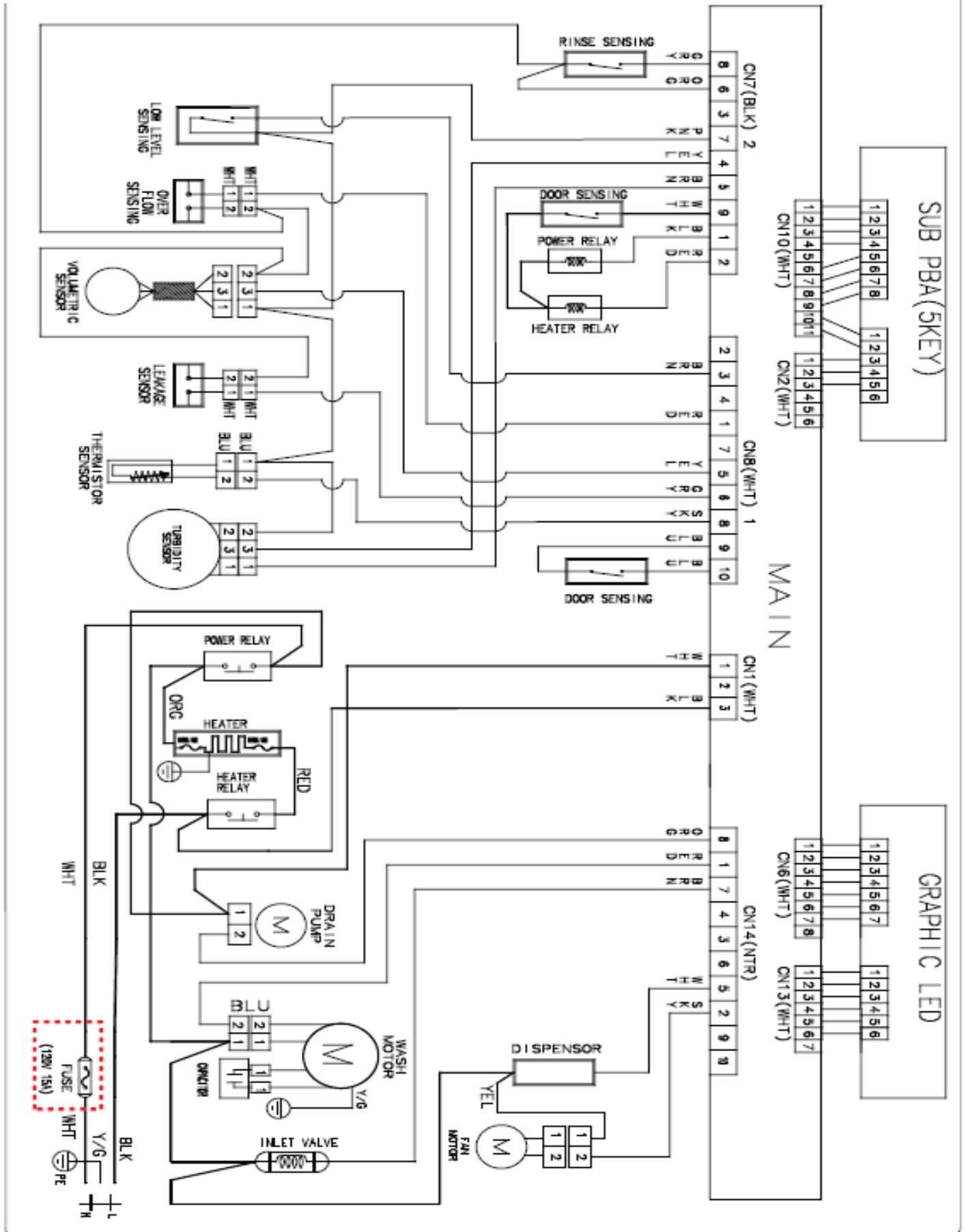

Wiring Diagram before 5-1-2009 DMR77 / 78

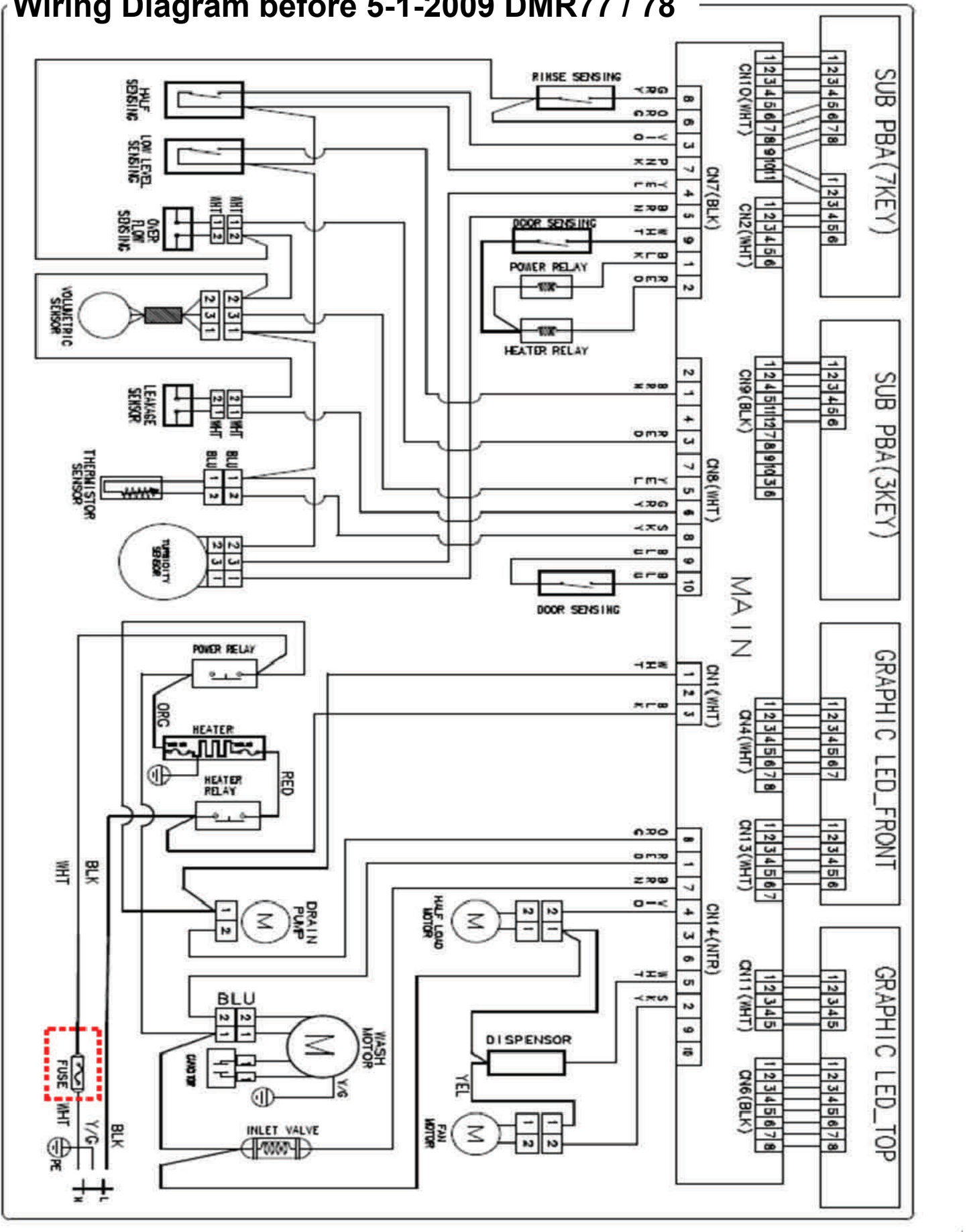

PCB after 5-1-2009

- CN302**
 1-Power Relay Driver
 2-Heater Relay Driver
 3-Half Load Sensor
 DMR77-78 only
 4-Trubidity Sensor
 5-Trubidity Transmitter
 7-6 5vdc
 8-Rinse Aid Sensor
 9-6 12vdc

- CN01 CN1 PBA Power**
 1 120vac
 3 120vac

- CN802 LED 5vdc Driver**

- CN501 Disp LED Driver**

- CN502 Disp LED Driver**
 DMR77-78 only

- CN801 Key Driver**
 11-12 5vdc

- CN803 Key Driver**
 DMR77-78 only
 10-11 5vdc

- CN504 Display LED Driver**
 DMR77-78 only

- CN301**
 1-Low Water Sensor
 3-Overflow Sensor
 5-Water Counter
 6-Leakage Sensor
 8-Thermistor
 9- 12vdc
 10-Door Check Receiver

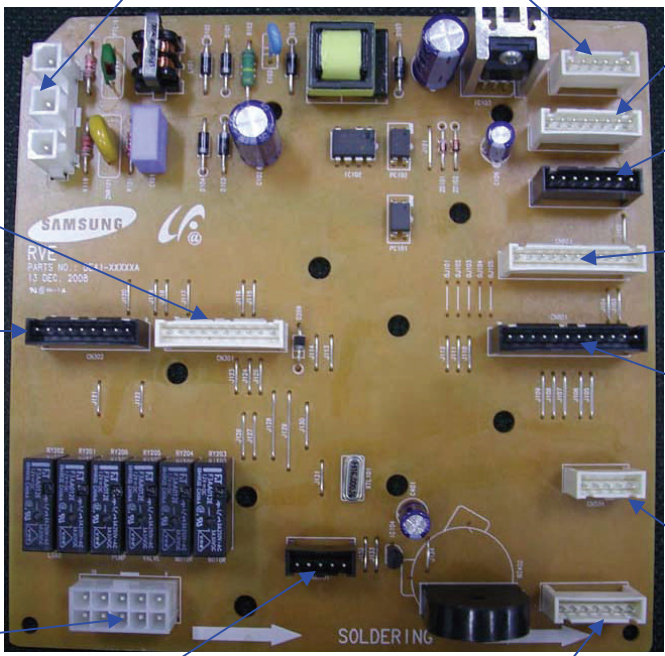

- CN201**
 1-Distribution Mtr
 DMR77-78 only
 2-Half Load Mtr
 DMR77-78 only
 4-Vent Mtr
 5-Circulation Mtr
 7-Inlet Valve
 8-Drain Pump

- CN701 MICOM Writer**
 3-1 5vdc

- CN503 Display LED Driver**

PCB before 5-1-2009

- CN7**
 1-Power Relay Driver
 2-Heater Relay Driver
 3-Half Load Sensor
 DMR77 only
 4-Trubidity Sensor
 5-Trubidity Transmitter
 7-6 5vdc
 8-Rinse Aid Sensor
 9-6 12vdc

- CN1 PBA Power**
 1 120vac
 3 120vac

- CN2 LED Driver**

- CN4 Disp LED Driver**
 DMR77 only

- CN6 Disp LED Driver**

- CN9 Key Driver DMR77**
 12-11 5vdc

- CN10 Key Driver**
 11-10 5vdc

- CN11 Disp Driver DMR77**

- CN8**
 1-Low Water Sensor
 3-Overflow Sensor
 5-Water Counter
 6-Leakage Sensor
 8-Thermistor
 9-Door Check Driver
 10-Door Check Receiver

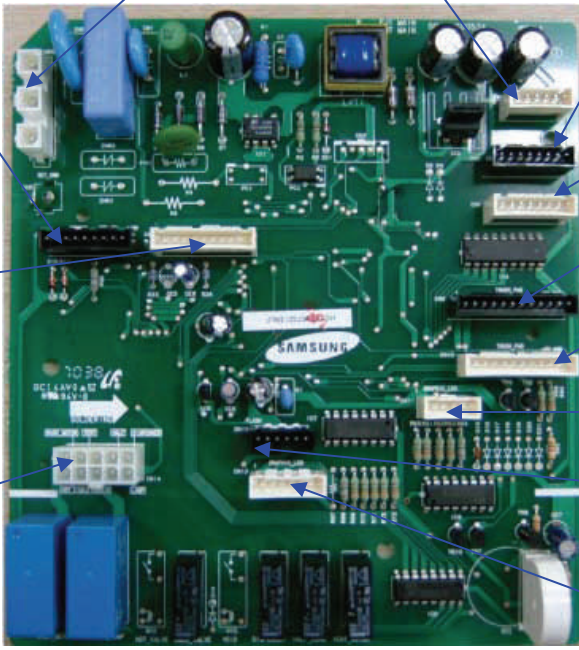

- CN12 MICOM Writer**
 2-5 5vdc

- CN13 Display LED Driver**

- CN14**
 1-Circulation Mtr
 2-Fan Mtr
 4-Distribution Mtr
 DMR77 only
 5-Dispensor
 7-Inlet Valve
 8-Drain Pump

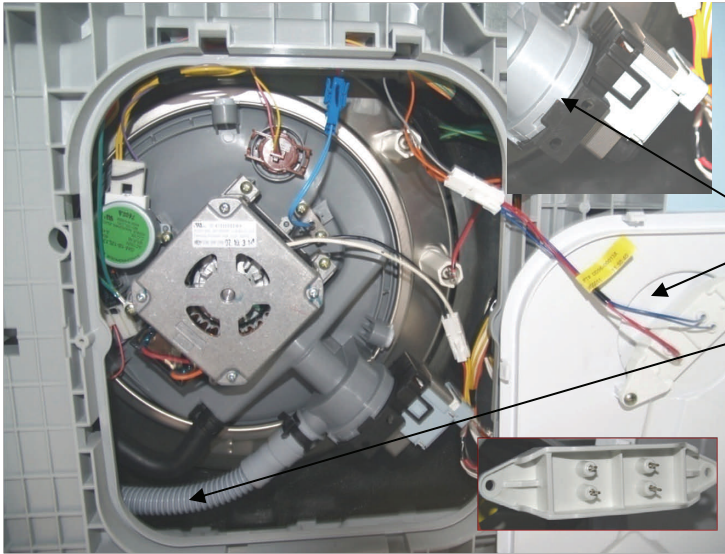

Leaking “LE” Code

Moisture creates resistance between the pins. **ALWAYS** clean the area below the pins after troubleshooting.

Check Pump Ass’y for proper twist lock.

Condensation may form on the tray from uninsulated outside walls or large hole in the floor to a cold basement.

Check Drain Hose for cut or small hole.

Check all components mounted to the sump for any leakage.

Cavitation “surging” In Prewash

During the first fill (pre-wash), the water level supplied to circulation pump drops, while water is distributed through the spray arms and tower assembly (resulting in cavitation.) During the next fill, voids in these areas are already filled with water and level is sufficient (no cavitation.) Between uses, water in the spray arms and tower assembly completely bleed out, leaving them empty. At the beginning of next use, the D/W will pump for 45 seconds before filling and cavitation will occur during the prewash. Inform the customer that the cavitation “SOUND” is part of normal operation.

If Cavitation Occurs During All Cycles or is Intermittent

Make sure drain hose has not been moved from the side of cavity during Installation, verify proper “loop”.

Check for proper fill (valve and flow meter) in t1 test mode.

Water lost in distribution, such as inside cups, glasses, bowls that flip over can cause a drop in water supplying the wash motor and can cause cavitation sound during any cycle.

Detergent Door Not Opening

1. Never overfill the dispenser compartment with powder or liquid, only go below or up to fill line.
2. If there is residue around the dispenser door area. Previously undispensed, partially dispensed, or door stuck close issue) clean it with mild soap & water. The residue can foul the mating latch.
3. If the customer uses “tablets” or some self contained type of soap tab, make sure it is fully seated and the door does not ‘sandwich’ it shut.
4. Make sure that in the rack nearest to the dispenser door when the door is shut, is not obstructing the opening of the dispenser with some protruding utensil.

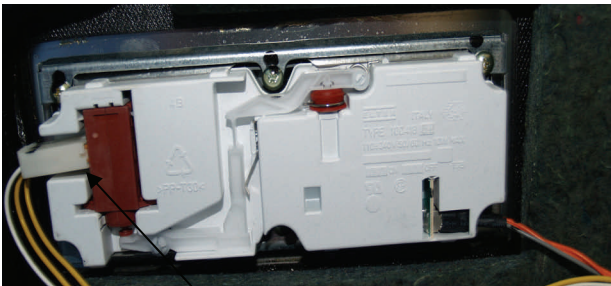

Testing The Detergent Door and Dispenser

1. Disconnect wires from disp. & close detergent door.
2. Connect Fused cheater cord and apply 120vac
3. In approximately 40 seconds the wax motor will open the door.
4. Remove power, allow wax motor to return.
5. Restore power to wax motor, in approximately 40 seconds the rinse aid will be activated. Remove power.
6. Close detergent door to repeat test

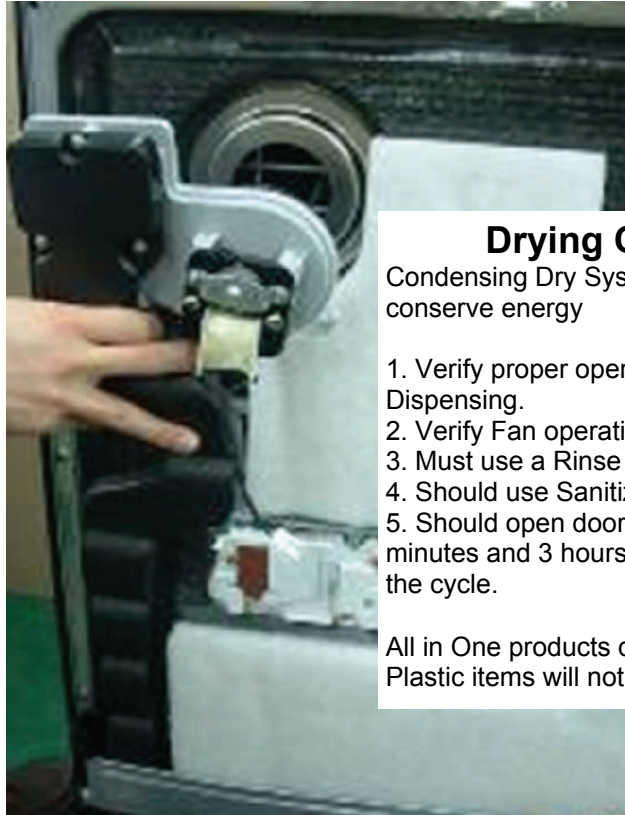
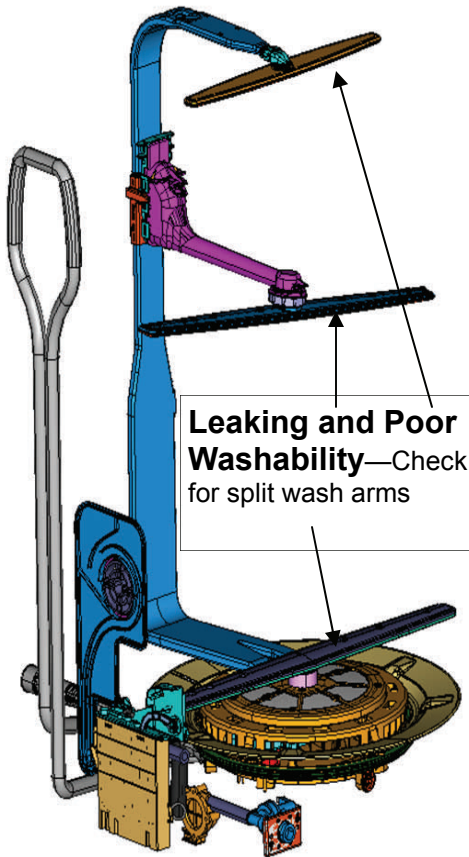

Drying Concerns

Condensing Dry System is used to conserve energy

1. Verify proper operation of Rinse Aid Dispensing.
2. Verify Fan operation.
3. Must use a Rinse Agent
4. Should use Sanitize Cycle
5. Should open door between 30 minutes and 3 hours after completion of the cycle.

All in One products do not dry as well. Plastic items will not dry properly.

Dishwasher Parts Change 5/2009

DMR77/78

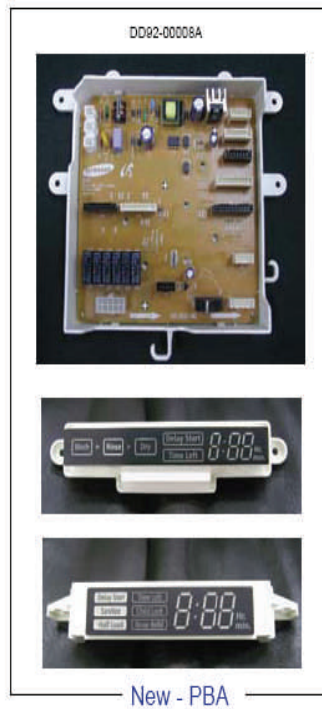
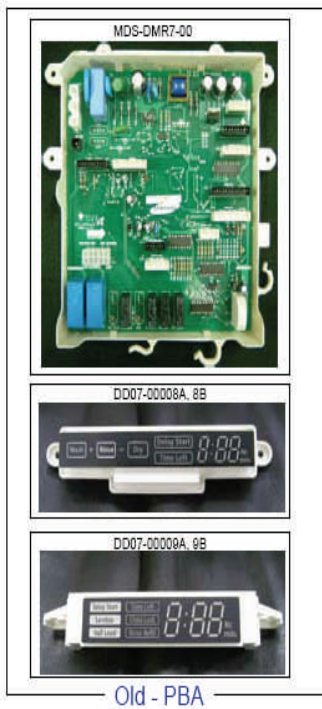

Components		
Component	Voltage	Ω
Water Valve	120vac	1.2 K Ω
Drain Pump	120vac	42.2 Ω
Heater	120vac	13 Ω
Half Load Mtr	120vac	2.6K Ω
Fan Mtr	120vac	150 Ω
Disp Wax Mtr	120vac	2.3K Ω
Circulation Mtr	120vac	16.5 Ω
Thermistor	Temp. (°F)	Resistance (k Ω)
	41	125.78
	50	98.323
	59	77.454
	68	61.465
	77	49.12
	86	39.517
	95	31.996
	104	26.065
	113	21.385
	122	17.599

DMR57

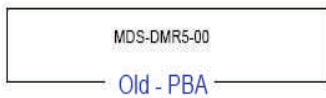

Samsung 'Dishwasher' Diagnostic Code Quick Guide

<u>Error Type</u>	<u>Error Mode</u>	<u>Cause</u>	<u>Reason</u>	<u>Tests Without Pulling D/W</u>
Water Supply Error	4E	1. When the pulse of 100 or less is detected 1 minute after the water supply starts 2. When flow meter pulse is 5 or less 5 seconds after the water supply starts 3. No water detected 5 min after start	Water supply valve defect, Flow Meter defect, Particles within water supply valve, Water supply valve terminal not connected, Main PBA defect	Check valve resistance and voltage at brown wire at CN14 to yellow wire at detergent dispenser 1.2 K ohms @ 120vac
Water Supply Error Temp Sensor Error	4E1 . . tE1	When 80°C or above is detected during water supply . . When 0.2V or below, or 4.5V or above is maintained for over 3 seconds	Thermistor Defect, Water supply temperature of 80°C or above, Main PBA defect . Thermistor terminal not connected Thermistor Defect, Main PBA defect	Perform service test t3, for 3 minutes and compare display temp with actual water temp Celsius. It should be within about 8 degrees C. Difference due to tank vs. sump temperature.
Drain Error	5E	When OFF status of Low Level S/W is not detected within 3 minutes during the drain	Drain pump defect, Low Level Sensor defect, Particles clogging mater drain hose, Drain valve terminal not connected Main PBA defect	Perform service test t6 Check motor resistance and voltage at white on CN1 to orange wires at CN14 42.2 ohms @ 120vac
Over-flow Error	oE	When overflow detection AD data is 4.0V or below for 3 seconds (When leakage sensor detects 4.0V or below for 1 seconds during water supply)	Foreign particles in water supply valve, Case Sensor part leakage, Flow Meter defect, Main PBA defect	
Leakage Error	LE	When leakage sensor detects 4.5V or below for 1 seconds	Base part hose connection defect Sump and Tub assembly defect Drain Pump assembly defect Main PBA defect	
Heater Error	HE . . . HE1	When the temperature change is 4°C or less within the first 10 minutes after the heating starts. . . When the temperature of the Thermistor is 80°C or above for more than 3 seconds	Heater defect Heater Relay defect Heater terminal not connected Main Wire-Harness defect Main PBA defect . Heater Relay defect Thermistor defect Main PBA defect	Perform service test t3, will heat water approximately 1 degree C per minute If not working relay driver voltage is on main pcb red wire CN7 to white wire on door switch on right looking at back of panel. Will read approximately 50 ohms and 12vdc off and 0.5vdc on.
Low Water Level Error	9E	When Low Level is detected to cause Error even after the water supply resumes after Low Level is detected for the 1st time	Low Level Sensor defect Low Level Sensor not connected Main PBA defect	service test t6 no water in tub = OFF, water in tub = ON possible float or micro switch issue
Button Error	bE2	When the button is pressed continuously for over 30 seconds	Sub PBA defect Main PBA defect	Check for moisture in console
Half Load Error	PE	When micro s/w is not detected for over 30 seconds after the Distributor motor starts	Distributor motor defect Micro sw terminal not connected Main PBA defect	Perform service test t8 Violet wire CN 14 to Yellow wire at detergent dispenser 2.6 K ohms @ 120vac

Service Inspection Mode	Press the Delay Start + Normal + Power keys at the same time	“ALL” is displayed for the first three (3) seconds and then “t1” You can change the mode by pressing the Normal key. Each time the Normal key is pressed, the mode changes in the order of t1 → t2 → t3 → t4 → t5 → t6 → t7 → t8.		
Mode	Related parts	Symptoms	Activate Mode	Live Test Notes
t1	Inlet valve, Flow Meter, Low Level Sensor	4E error 9E error	If you press the Delay Start key, water is drained for 45 seconds and then the water supply starts. If the pulse count is more than 660, change the mode. Make sure to change the mode when the pulse count is more than 660 in t1 mode.	Water fill in approximately 70 seconds average water pressure, fills to about 1" past heater shield (very little water showing in unit)
t2	Circulation Motor	Nozzle does not spray	1. Press the Delay Start key to start or stop the pump. 2. If a low water level is detected, water is supplied again and the operation continues.	Place some cups on racks and run circulation pump to verify water distribution in tub.
t3	Circulation Motor, Heater, Thermistor	HE error	1. Press the Delay Start key to start or stop heater and circulation pump. 2. If a low water level is sensed, water is supplied again and the operation continues. 3. The current temperature is shown on the display. 4. It operates up to 70°C.	After temp increases 2 degrees C, time is about 50 seconds for each degree C increase
t4	Fan Motor	Fan Motor not working	Press the Delay Start key to start or stop the fan motor.	Listen for fan running
t5	Drain Pump, Low Level Sensor	5E error	1. Press the Delay Start key to start the 2 parts. 2. “t5” starts blinking while water is being drained. 3. When draining is finished, “t5” is displayed without blinking.	pump out is approximately 30 seconds
t6	Low Level Sensor	Display error when turning Micro S/W on/off	1. MICRO SWITCH On The sensing state is displayed as ‘On’ on the display. 2. MICRO SWITCH Off The sensing state is displayed as ‘OFF’ on the display.	t6 to OFF with no water – t6 to ON with water
t7	Thermistor	No change in water temp	The current temperature is displayed.	Actual temp C of water in sump
t8	Synchronous Motor, Micro S/W	PE Error	1. If you press the Delay Start key, the parts operate just once. 2. There is no stop function. 3. While the synchronous motor is operating, its sensing state is displayed as On/OFF on the 88 segment display. 4. When the synchronous motor stops, the sensing state (On/OFF) of the micro switch is displayed.	ON 8 seconds, OFF 4 seconds