

SERVICE NOTE BOOK
UNDERCOUNTER DISHWASHER
(VUD141)



VIKING RANGE CORPORATION ®

TABLE OF CONTENTS

Model / Serial Number.....	3
Cycle Options.....	3
Superclean System.....	5
Trouble Shooting.....	5
Voltage / Resistance Readings.....	7
Poor Dishwashing Results.....	8
Wiring Schematic.....	12
Cycle Sequence Chart.....	12
Block Diagram.....	13
COMPONENT LOCATION:	
Lower Access Panel.....	14
Casing and Related Parts.....	15
Door.....	16
Dishwasher System.....	17
Electrical Equipment.....	18
Interior Light.....	19
SERVICE:	
Door Panel Removal.....	20
Drain Pump Removal.....	20
Circulation Pump Removal.....	20
Pressure Switch Removal.....	20
Foam Float.....	20

UNDERCOUNTER DISHWASHER (VUD141)

Serial stickers are located on the right side of the door.

When your serial number has 12 digits you will need to remove the last 4 digits to read the manufactures date code;

EXAMPLE: MODEL #VUD141 / SERIAL # 971900216609

97 (year) 19 (week) 0021 (production code)

- | | | |
|--|--|--|
| <ul style="list-style-type: none">• Turn on the power switch | <ul style="list-style-type: none">• Select 140°F Water and Heated or No Heat Dry
OR
Select 165°F Water and Heated or No Heat Dry | <ul style="list-style-type: none">• Turn the control knob to either Rinse / Hold or one of the wash settings. The dishwasher will start. |
|--|--|--|

Which cycle/option to select

140°F / SANI CYCLE 165°F

You may select 140°F or 165°F water temperature for the first fill of the pots/pans cycle and for the main wash and final rinse of all full cycles. It is recommended to use 140°F water for normal day-to-day dishwashing. Select 165°F water for special sanitizing benefits.

HEATED / NO HEAT DRY

You may select heated or no heat dry with any wash cycle. Dishes will dry more completely with heated drying, however, no heat drying is more economical. When using no heat dry, the dishwasher will go through the same entire timed drying cycle, but with no added heat.

RINSE / HOLD

This program provides a single, unheated rinse to be used when waiting to start a complete wash cycle. For example, it is useful in rinsing salty or highly acidic foods off stainless steel, silver and silver plate if you are not planning on running the dishwasher through a wash cycle immediately after loading such items.

POTS / PANS

This setting includes three prewashes for extra cleaning. Use it for cleaning heavily soiled items such as pots, pans, and baking dishes.

NORMAL WASH

Use this setting, with its two prewashes, for normally soiled dishes.

LIGHT / CHINA

This setting, with one prewash, is used for washing lightly soiled and/or delicate items.

PLATE WARM

With a completely clean dishwasher, load the plates, set the cycle selection knob to plate warm, and then turn the power heat knob to heated dry. This setting is a dry heat cycle for warming plates. No water is involved.

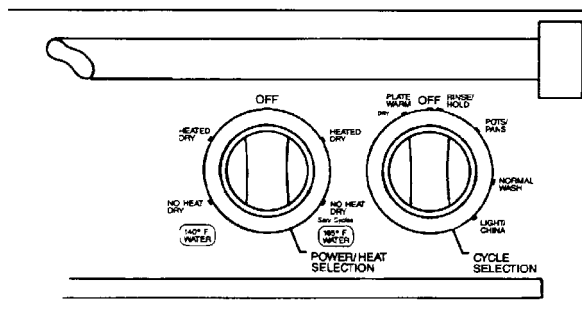

VUD 141 DISHWASHER

The vent solenoid is adjustable by approximately 1/4 “. Don’t adjust beyond the 1/4”.

Drying time is 12 minutes, however the heating element doesn’t stay n all the time. The T-stat sets the temperature to 140 degrees or 165 degrees depending on the temperature control setting and will cycle during the drying cycle.

Normal wash cycle will be approximately 1.5 hours when the input water is less than 145 degrees. Normal wash cycle will be approximately 3/4 hour when the input water is over 145 degrees.

The water is heated while recirculating.

Dishwasher cycles water usage/time

CYCLE	TOTAL WATER GALLONS (APPROX.)	TOTAL TIME-MINS. (APPROX.) 55°F INPUT WATER		TOTAL TIME-MINS. (APPROX.) 120°F INPUT WATER		TOTAL TIME-MINS. (APPROX.) 140°F INPUT WATER	
		140°F	165°F	140°F	165°F	140°F	165°F
		RINSE / HOLD	1.0 (3.8L)	3	3	3	3
POTS / PANS	5.9 (22.5L)	103	129	84	111	76	109
NORMAL WASH	4.9 (18.8L)	90	106	75	95	69	81
LIGHT / CHINA	3.9 (15.0L)	84	100	68	86	63	77
PLATE WARM	-	8	8	8	8	8	8

How the dishwasher works

CYCLE	PREWASH	MAIN WASH	RINSE	DRY
RINSE / HOLD			<input type="checkbox"/>	
POTS / PANS	<input checked="" type="checkbox"/> <input type="checkbox"/> <input type="checkbox"/>	<input checked="" type="checkbox"/>	<input type="checkbox"/> <input checked="" type="checkbox"/>	<input checked="" type="checkbox"/>
NORMAL WASH	<input type="checkbox"/> <input type="checkbox"/>	<input checked="" type="checkbox"/>	<input type="checkbox"/> <input checked="" type="checkbox"/>	<input checked="" type="checkbox"/>
LIGHT / CHINA	<input type="checkbox"/>	<input checked="" type="checkbox"/>	<input type="checkbox"/> <input checked="" type="checkbox"/>	<input checked="" type="checkbox"/>
PLATE WARM				<input checked="" type="checkbox"/>

= WATER IS HEATED TO 140°F (60°C) OR 165°F (74°C)

= WATER IS NOT HEATED

= HEATED OR NO HEAT DRY

Super clean system: Normal cycle

- 1) Set Temperature
- 2) Turn to On
- 3) Drain Pump will be on for 30 sec.
- 4) Fill Valve will open for 60 sec. Supplying 1.3 gallons of water.
- 5) Prewash for 5 or 6 min (Not Heated)
- 6) Drain Pump turns on and drains water to just over the top of the filter (1/8")
- 7) Then the Circulating Pump turns on the 45 to 50 sec. to wash the bottom of the tank and filter.
- 8) Actions stops for 1 minute.
- 9) The Drain Pump turns on and drains unit
- 10) The Fill Valve turns on and regular wash begins.
- 11) After water reaches the set temperature the unit will wash for 20 minutes.
- 12) Stops
- 13) Drain Pumps for 30 seconds.
- 14) Fill Valve on for 60 seconds (1 minute)
- 15) Rinses for 4 minutes.
- 16) Drains .
- 17) Refills for 2nd rinse (5 minute rinse cycle after reaching set temperature.)
- 18) Drains
- 19) Heating Element on for drying cycle. (The heating element will cycle on and off depending on the temperature setting during the drying cycle.)
- 20) Vent opens after 30 seconds into the drying cycle.
- 21) Drying cycle is approximately 12 minutes.

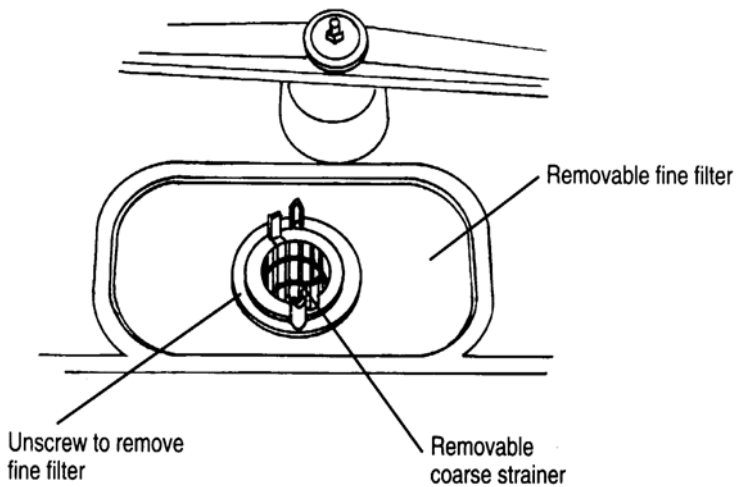

- Plugged fine filter: Unscrew horizontal filter which is located in the center of fine filter. Remove the filter and clean the underside . Replace fine filter and screw horizontal filter back in place.
- Lift out the coarse strainer and empty the large objects that cannot pass through the drain pump.

To clean pump:

- You can reach the drain pump from inside the machine. First remove the coarse strainer and the fine strainer. Then you can remove a small cover in the bottom of the hole. There you can reach the pump impeller and remove the dirt. Replace the cover, strainer and fine filter.

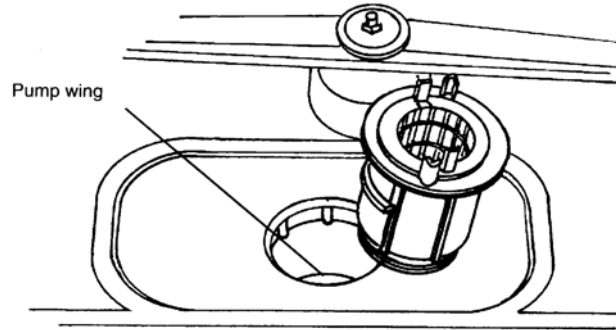

Trouble shooting

- **There is water left in the dishwasher:**

If the dishwasher is taking in too much water, the drain pump starts automatically. If the water, in spite of this, is not drained off, it might depend on any Of the following reasons:

- 1) The filter is clogged. (See Pg.#3)
- 2) The pump is blocked. Pieces of bone or other foreign particles in the drain pump, (See above)
- 3) The drain hose is clogged (blocked). Check to make sure that there are not obstacles in the hose where it connects to the water. Foreign particles can get lodged in the entrance of the connection line (see illustration). Also, check to make sure that the cone-shaped connection line has been cut to an inner diameter of at least 3/4".

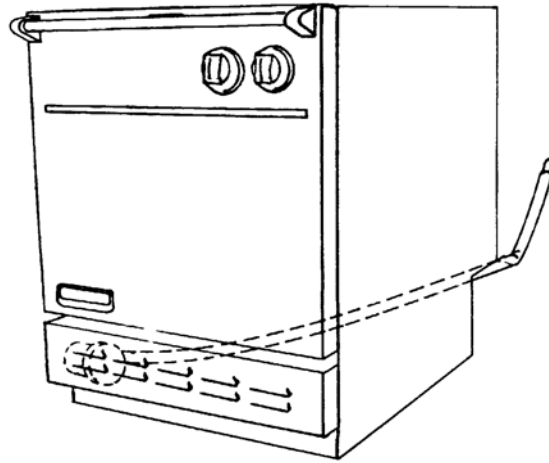

- **The Drain Hose is Kinked:**

Check to make sure that there are no kinks in the drain hose.

- **Air Gap:**

If the machine is equipped with an air gap, be sure the air gap is not blocked or plugged. 1) Keep air gap clean. 2) Check air gap first if the drain becomes blocked and there is water left in the dishwasher.

- **The Dishwasher does not start Check the following:**

- 1) The door is not completely closed.
- 2) The POWER / HEAT knob is in the "off" position.

- 3) The CYCLE SELECTION knob is in the "off" position.
- 4) A fuse is blown or a breaker is open, check the electrical box.
- 5) The safety overflow float / switch in the base pan under the tank has turned off all power to the dishwasher. This means that there is leak and water is accumulating in the base pan.

The PRESSURE (LEVEL) SWITCH closes the INLET WATER VALVE when the dishwasher has taken in too much water.

LOW WATER consumption--4.6 gallons in the normal cycle.

LOW DETERGENT consumption because of low water usage.

VOLTAGE READINGS

POINT	NORM	DRAIN	HEAT	WASH	DRY
*DRAIN PUMP	120	120	120	120	120
*BLOWER	120	120	120	120	120
SOAP SOL.	0	0	3	0	3
TIMER POINTS					
P1	0	120	3	120	3
P1B	0	120	3	9	3
P2a (INLET VALVE)	0	120	3	0	3
P3	0	120	3	120	3
P4	120	120	120	120	120
P4a	0	120	120	120	120
P5b	6	6	10	15	7

***Drain Pump** and **Blower Fan** will always have voltage present. The **Timer** completes the circuit to allow the **Motors** to run. This is normal and should not be considered a **Timer** fault.

RESISTANCE READINGS

THERMISTOR	25K
INLET VALVE	480
SOAP DISH	320
SOLENOID	
VENT SOLENOID	2K
HEATER	10
DRAIN PUMP	23
CIRC. PUMP	12
VENT BLOWER	260
THERMOSTAT	2K

All **resistance** readings should be taken with the component disconnected and **no voltage** present so as not to damage **meter**.

POOR DISHWASHING RESULTS

Try the following remedies. Poor results may not always be caused by the dishwasher. Read through the chart below before contacting your servicer.

Problem	Possible Cause	Suggested Remedy
Spotting and filming	Hard water	<p>Use the maximum recommended amount (3 tablespoons) of dishwasher detergent. You may need a home water softener.</p> <p>To remove hard water spots, try a vinegar rinse:</p> <ul style="list-style-type: none"> • Wash and rinse load as usual. • Remove all metal items from dishwasher. • Do not add detergent. • Pour two cups of vinegar into a bowl and set it on the bottom rack of the dishwasher. • Run the dishes through an entire wash program. <p>If the vinegar rinse doesn't work, repeat the above process substituting 1/4 cup citric acid crystals (available at most drug stores) for the vinegar.</p> <p>Wiping with a damp cloth should remove spots from metal items. For sterling and silver plated flatware, rub with a towel, or use a good cream silver polish.</p>
	Filter system	Check filter system to be sure it is clean and properly installed.
	No rinse aid	Does the rinse aid dispenser need to be filled? (Note: use only in hard water areas.)
	Too little water	<p>Check that the water valve is fully open. Make sure that the water pressure is between 15 and 176 PSI.</p> <p>Check the filter in the inlet valve.</p>
	Dishwasher detergent	<p>Use only the correct amount of dishwasher detergent according to the hardness of the water and the wash program you have selected. Do not use old or caked detergent. Store the dishwasher detergent in a dry place and in a closed container.</p> <p>Change the dishwasher detergent if the result is still unsatisfactory.</p>
	Items not loaded properly	<p>Check that you loaded the items according to the instructions on pages 6-7.</p> <p>Do not overload. Make sure water can reach all soiled surfaces.</p>
	Wash arms rotate poorly or stand still	<p>Check that both wash arms can rotate freely and that items do not obstruct the movement of the wash arms. Lift the arms and make sure that no grains of dirt, etc. retard the rotation of the wash arms. If necessary, clear the obstruction, refit the arms and check that they rotate freely.</p> <p>Make sure that the holes in the wash arms are not blocked by dirt. If necessary, clear the holes with a pointed object.</p>
	Strainer blocked	Check the strainer. Clean if necessary. See the instructions on page 12.
	Excessive foam in the machine	Use only dishwasher detergent.
	Flatware incorrectly loaded	Pay particular attention to spoons so that they do not nest in each other and prevent water penetration.

POOR DISHWASHING RESULTS

Try the following remedies. Poor results may not always be caused by the dishwasher. Read through the chart below before contacting your servicer.

Problem	Possible Cause	Suggested Remedy
Small particles deposited on items	Wash arm or arms not rotating freely	Be sure a utensil or handle has not prevented their turning.
	Detergent	Use only fresh detergent, store in a tightly closed container in a cool dry place. Fill dispenser only when ready to start the dishwasher. Use the recommended amount of detergent, especially with hard water.
	Low water pressure	Check that the water valve is fully open. Make sure that the water pressure is between 15 and 176 PSI.
	Improper loading of dishes	Load dishes to prevent water and detergent from being trapped in or between items. Water should circulate freely.
Marks and discoloration	Aluminum utensils rubbing against items during washing	Be sure aluminum utensils, especially light weight foil-type pans, do not touch dishes. To remove spots, use a non-abrasive cleaner.
Yellow or brown marks	Iron or manganese in water	Temporary solution: Pour 1 teaspoon to 1 tablespoon of citric acid crystals in instead of the prewash detergent directly on the inside of the door. Follow this prewash with a full detergent wash. Use the pots / pans or normal wash cycle. Permanent solution: Install an iron removal system in the water supply.
	Copper with sterling silver	Yellow film on sterling silver results when you wash copper utensils in the same load. Silver polish will usually remove this stain.
	Tea or coffee (tannic acid)	Tea or coffee can stain cups. Remove stains by hand, using a solution of 1/2 cup bleach and 3 cups warm water. (Do not use on sterling silver or silver plate.)
Discoloration of stainless steel silver plate or sterling silver	Allowing salty or acidic foods to remain on flatware	Rinse flatware that is to stand several hours before washing.
	Stainless steel contacting silver	Do not put stainless steel and silver flatware in the same silverware basket compartment. Direct contact between these metals can cause permanent damage to silver. Clean stained items with silver polish. Do not use abrasives on stainless steel or silver.

POOR DISHWASHING RESULTS

Try the following remedies. Poor results may not always be caused by the dishwasher. Read through the chart below before contacting your servicer.

Problem	Possible Cause	Suggested Remedy
Distortion of plastics	Plastic item has low heat tolerance	Plastics vary in their ability to tolerate heat. Check washing instructions for all plastic items to be sure they are dishwasher safe. If they are, place in top rack away from the heating element.
Marks on melamine and plastics	Porous material	Use a special cleaner for plastic. DO NOT use bleach or scouring powder on these materials.
Cloudy film on glassware-etching of glass	Too much detergent, especially in soft water Rinse aid used with soft water	If vinegar or citric acid rinse doesn't remove film, the cloudiness is "etching". This is permanent. To prevent etching, use the last amount (one teaspoon) of recommended dishwasher detergent if you have soft water. Use a good quality dishwasher detergent and rinse aid. Do not overload the machine. Water should circulate freely to assure adequate rinsing and draining. Use drying without heat. Use rinse aid in hard water areas only.
Dishes not dry	Non-heated drying No rinse aid Plastic items Improper loading or unloading Dry cycle interrupted	Be sure to select heated drying for the best results. Allow more drying time when using non-heated drying. Fill rinse aid dispenser. Rinse aid helps dishes to dry faster. (Note: Used only in hard water areas). Certain plastic materials are difficult to dry. Plastics may need towel drying. Do not overload or nest items. Be sure all surfaces drain well. Load items with concave bases so as much water as possible can run off. Unload the bottom rack first. Water from dishes in the top rack may be spilling into the bottom rack. If the door is opened during the heated dry cycle, the heating element comes back on after the door is reclosed. If the dishwasher door is opened immediately after the dry cycle is completed and then shut again, the vent door is closed, trapping warm humid air. It is best then to leave door open slightly.

POOR DISHWASHING RESULTS

Try the following remedies. Poor results may not always be caused by the dishwasher. Read through the chart below before contacting your servicer.

Problem	Possible Cause	Suggested Remedy
Detergent left in detergent compartment (detergent compartment will not open)	Compartment cover blocked	The cover may not be opening because of improperly loaded items. Move dishes that may be blocking it.
	Old detergent	If detergent is hard or caked in the box, throw it away. Use only fresh detergent. Add detergent to dishwasher right before starting it.
Chipping or breaking of glassware	Improper loading	Do not overload. Load between prongs, not over them. Glasses loaded over prongs will not be supported and may chip or break. Make sure glassware is secure and can't come loose. Always use the top rack for delicate items. Use the light/china cycle.
Unusual noise	Improper loading	Utensils may not be secure or something small may have dropped from the rack. Water may cause utensils to rattle. Make sure everything is securely placed in the dishwasher.
Water left in bottom of dishwasher near filters	Dishwashing cycle not complete	Allow dishwasher to complete cycle.
	Some is normal	Water left in removable coarse strainer is normal.
Dishwasher will not drain	Air Gap	Be sure air gap is not blocked or plugged.
	Drain hose	Check for kink in drain hose.
	Filter system	Be sure there is no blockage in filter system. Remove, clean and place back in dishwasher before starting dishwasher.
	Clogged drain pump	Clean drain pump. See page 13.
Dishwasher will not start	Blown fuse or tripped circuit breaker	Replace fuse or reset circuit breaker. Remove any other appliances from the circuit.
	Door not completely closed	Close tightly until you hear a click.
	Control on "OFF"	Turn the POWER/HEAT knob to the appropriate setting.
Dishwasher will not fill	Door open	Check that door is firmly closed.
	Controls	Check that dishwasher is on. (See "Dishwasher does not start" page 14.)
	Water feed line	Check to see that the water feed line to dishwasher is not crimped.
	Water supply	Be sure water is available and turned on.
Water backs up in sink when dishwasher drains	Food waste disposer and trap	Check disposer and trap at sink for blockage or food particles.

- AP DRAIN PUMP
- BB LIGHT SWITCH
- BE INTERNAL LIGHT
- CP CIRCULATION PUMP
- EL HEATING ELEMENT
- FL FAN
- IV FILL VALVE
- KD COMBI DISPENSER
- LB LIGHT SWITCH
- LU DOOR
- N LEVEL SWITCH
- P TIMER
- T THERMOSTAT
- WAX VENT DOOR SWITCH
- VB ROTARY SWITCH
- OB BASE PAN OVER-FLOW PROTECTION SWITCH

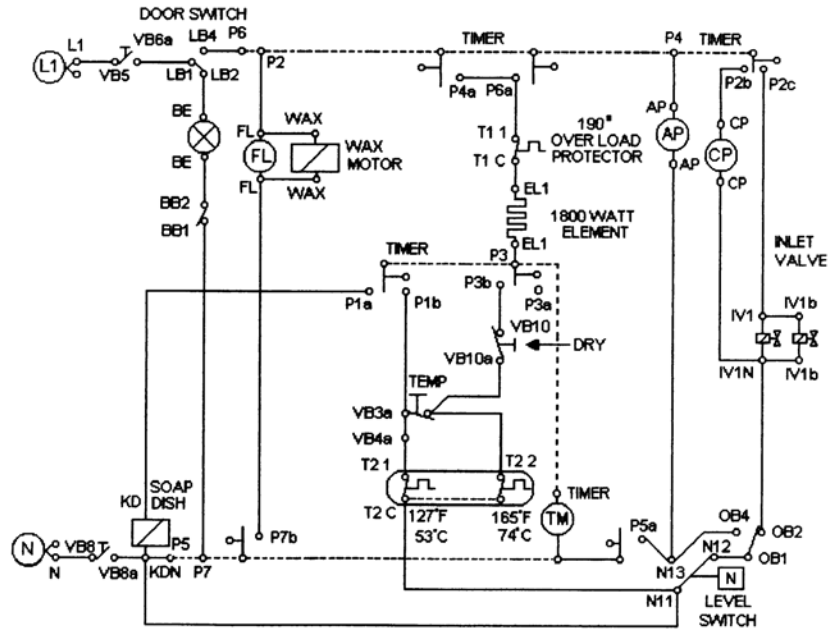

Internal connection -----

T21-127 F (53 C) T21- T2 COM
 T22-165 F (74 C) T22-

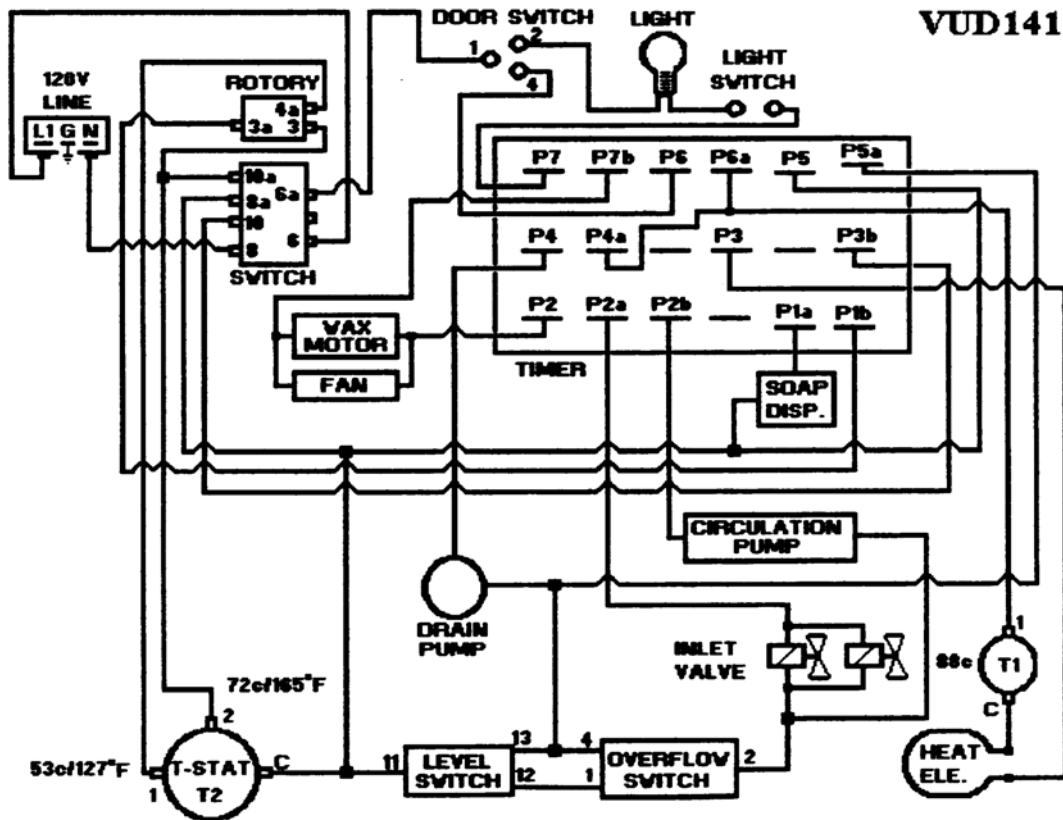

LOWER ACCESS PANEL

1. SOUND ABSORBING SLAB
2. PROTECTION PLATE
3. KICK PLATE
4. SEALING STRIP
5. KICK PLATE SPRING
6. DRIP GUARD PROTECTION
7. KICK PLATE BRACKET
8. KICK PLATE FELT
9. LOWER COVER

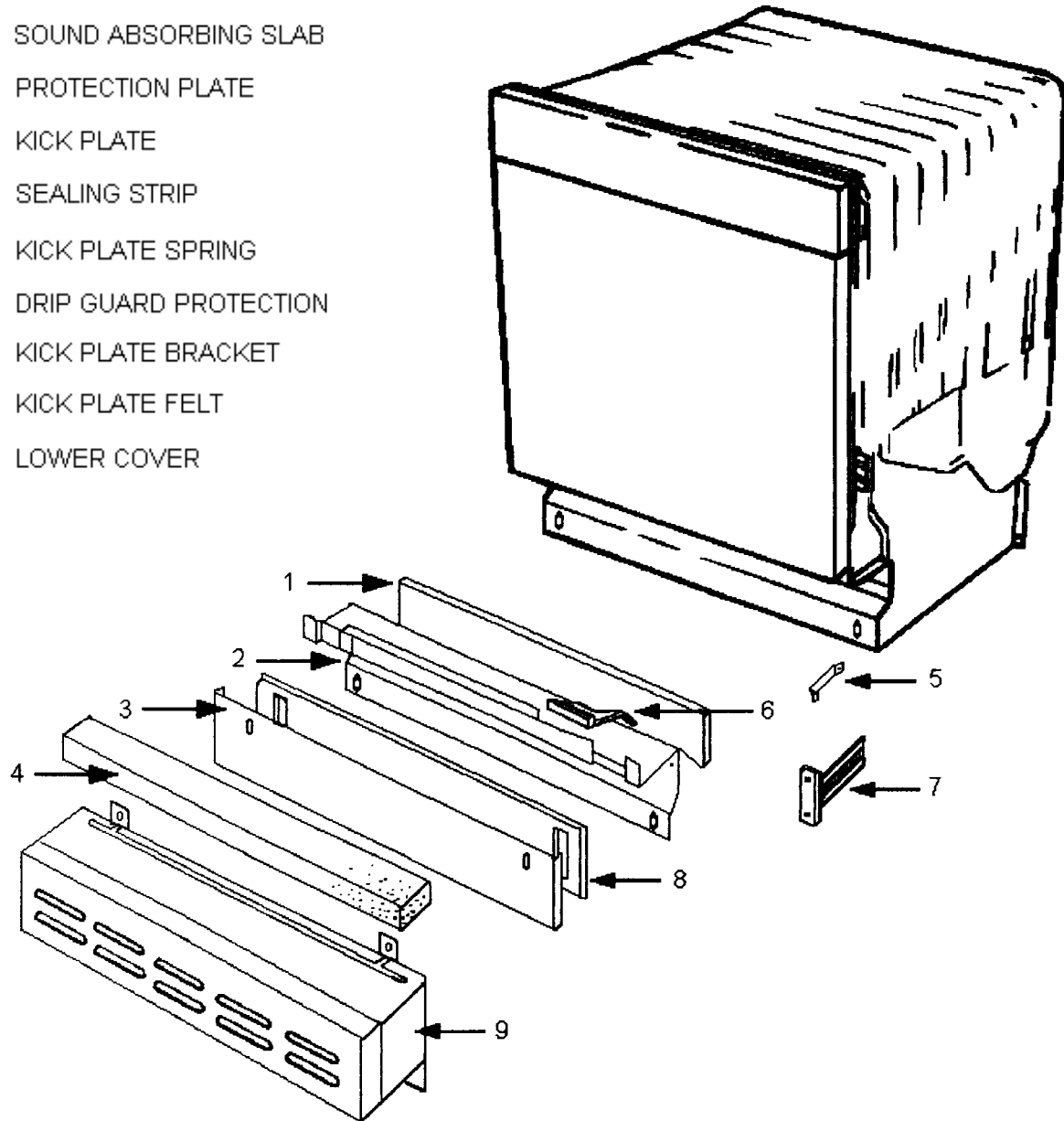

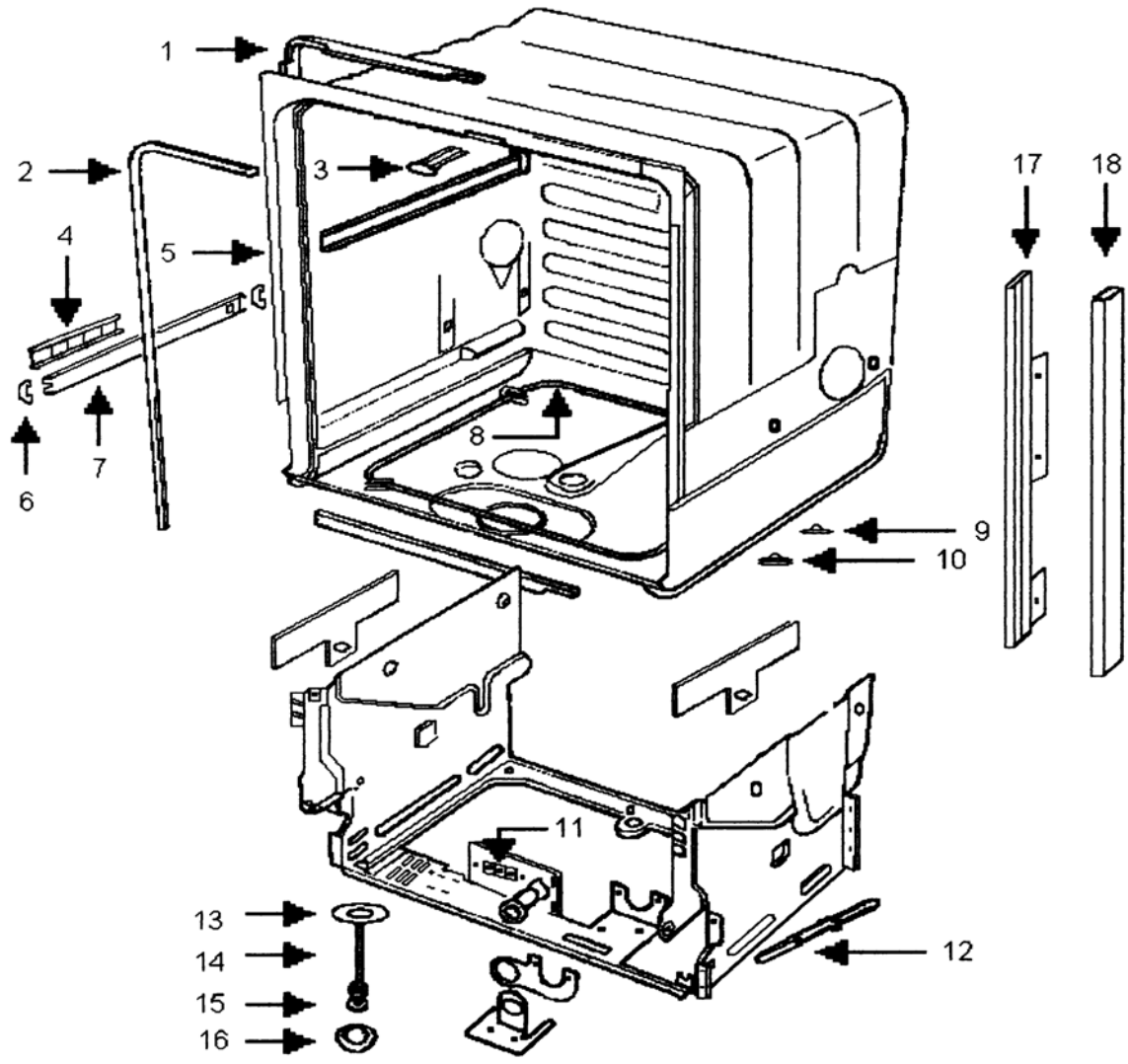

CASING AND RELATED PARTS

- | | |
|------------------------------|----------------------------|
| 1. Sealing Strip | 10. Thermostat (T2-Double) |
| 2. Door Strip | 11. Thermal Block |
| 3. Lock Catch | 12. Door Spring |
| 4. Guide Rail Bearing Holder | 13. Reinforcement Washer |
| 5. Tub | 14. Foot |
| 6. Basket Stop | 15. Nut |
| 7. Guide Rail | 16. Slide Foot (rear only) |
| 8. Heating Element | 17. Side Strip |
| 9. Thermostat (T1-Overload) | 18. Side Strip Seal |

DOOR

1. Wax Motor
2. Ventilator
3. Air Channel
4. Air Duct Nozzle
5. Micro-Switch
6. Lock Guard
7. Latch Handle
8. Latch
9. Lock Spring
10. Control Pin
11. Detergent Dispenser
12. Fan Cover Plate
13. Fan Casing Locking Ring
14. Timer
15. Rotary Switch
16. Handle
17. Handle Bracket (End Cap)
18. Bezel
19. Timer Knob
20. Inner Door Liner
21. Hinge Bearing (Slide Washer)
22. Door Hinge

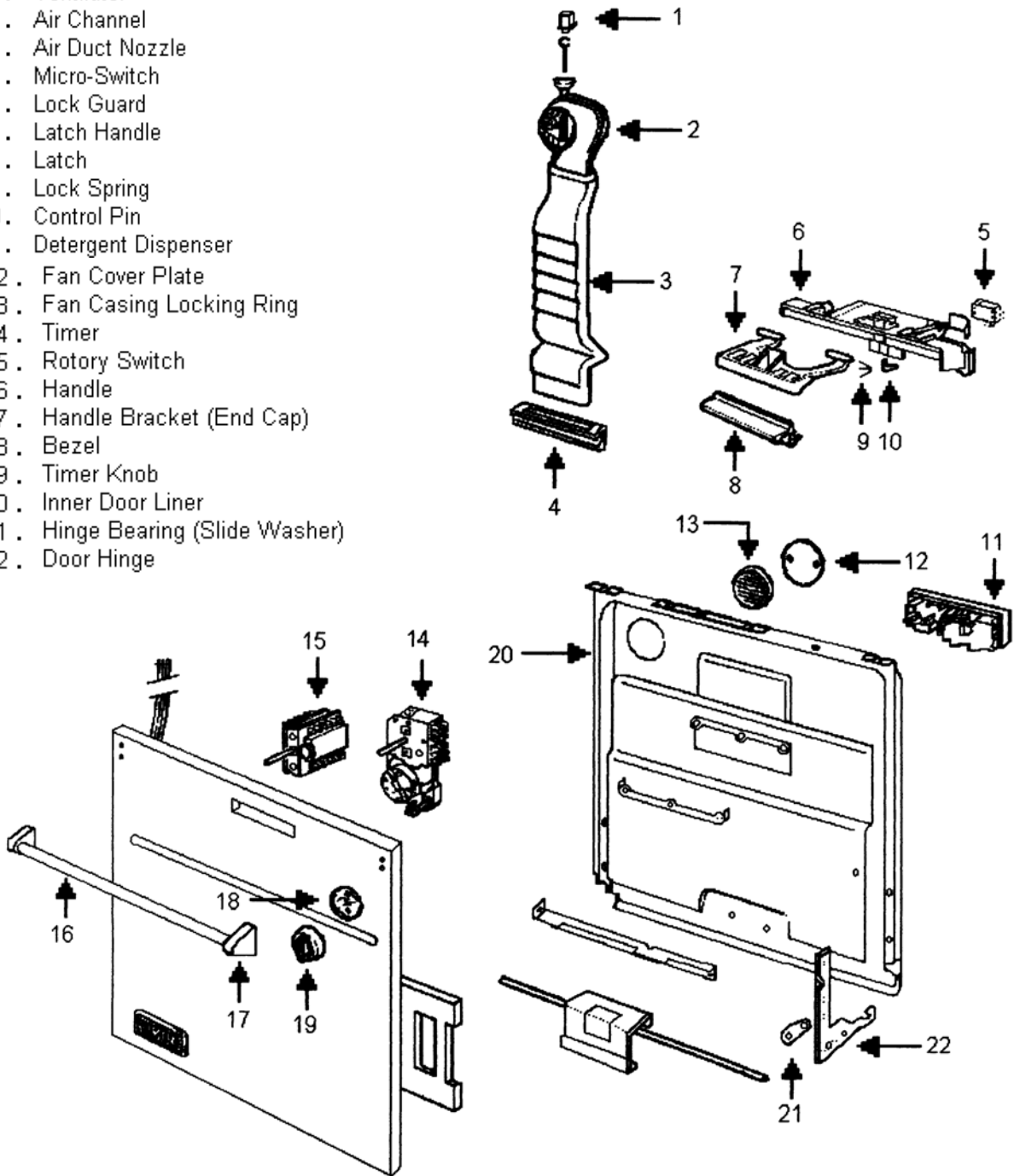

DISHWASHER SYSTEM

1. Upper Spray Arm
2. Air Brake with Lock Ring
3. Air Brake with "O" Ring
4. Air Brake Lid & Filter
5. Outlet Hose
6. Upper Strainer
7. Upper Spray Arm
8. Spray Pipe
9. Upper Spray Arm Bearing
10. Circulation Pump
11. Strainer Basket
12. Strainer Basket Insert
13. Bottom Well Lock Ring
14. Inlet Cover Plate
15. Outlet Pump
16. Bottom Well Cover Plate
17. Overflow Micro-Switch
18. Float
19. Bottom Well
20. Circulation Pump Hose (Front)
21. Lower Spray Arm
22. Lower Spray Arm Bearing
23. Spray Pipe Bearing (Muff)
24. Circulation Pump Hose (Top)
25. Inlet Hose
26. Rubber Hose

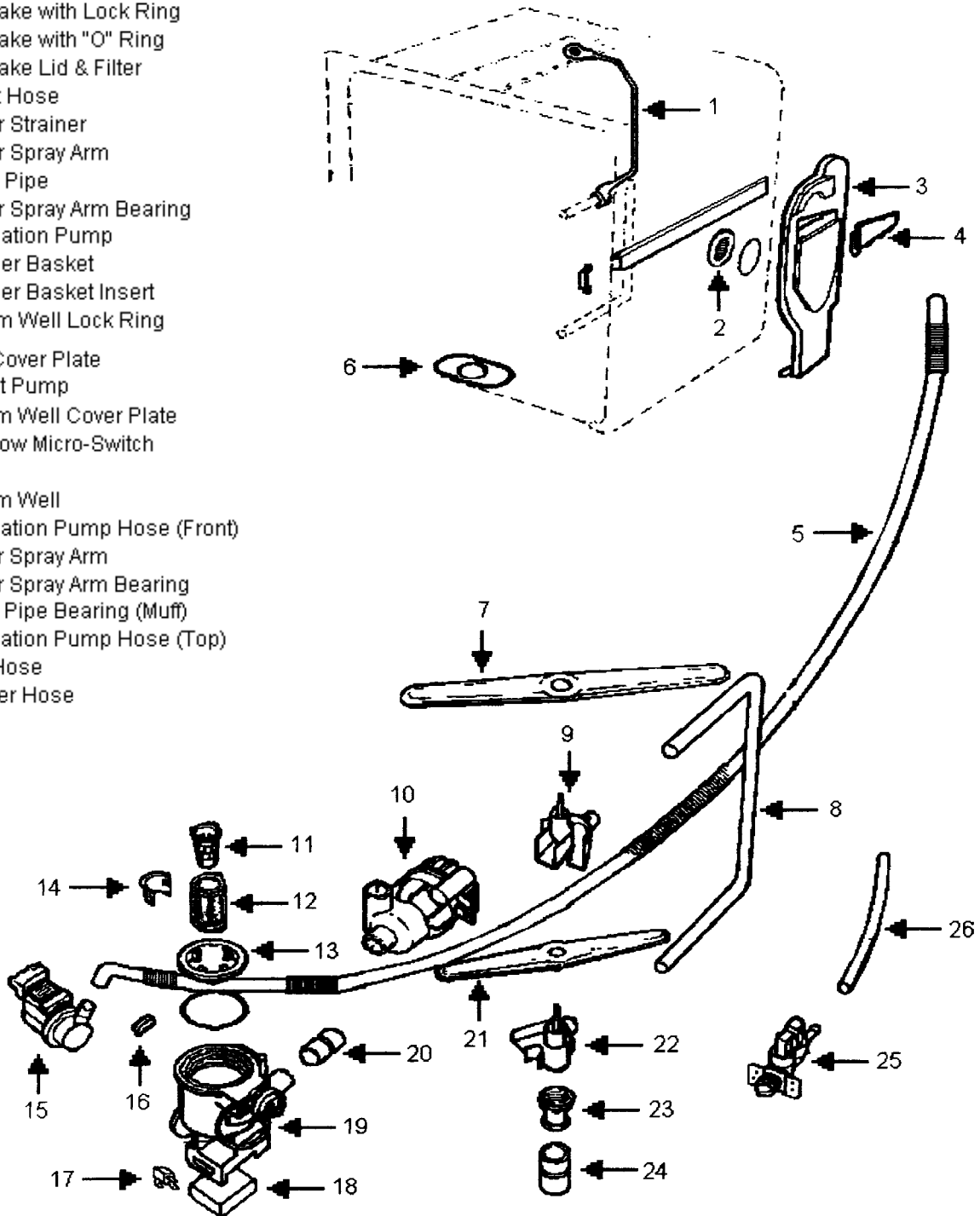

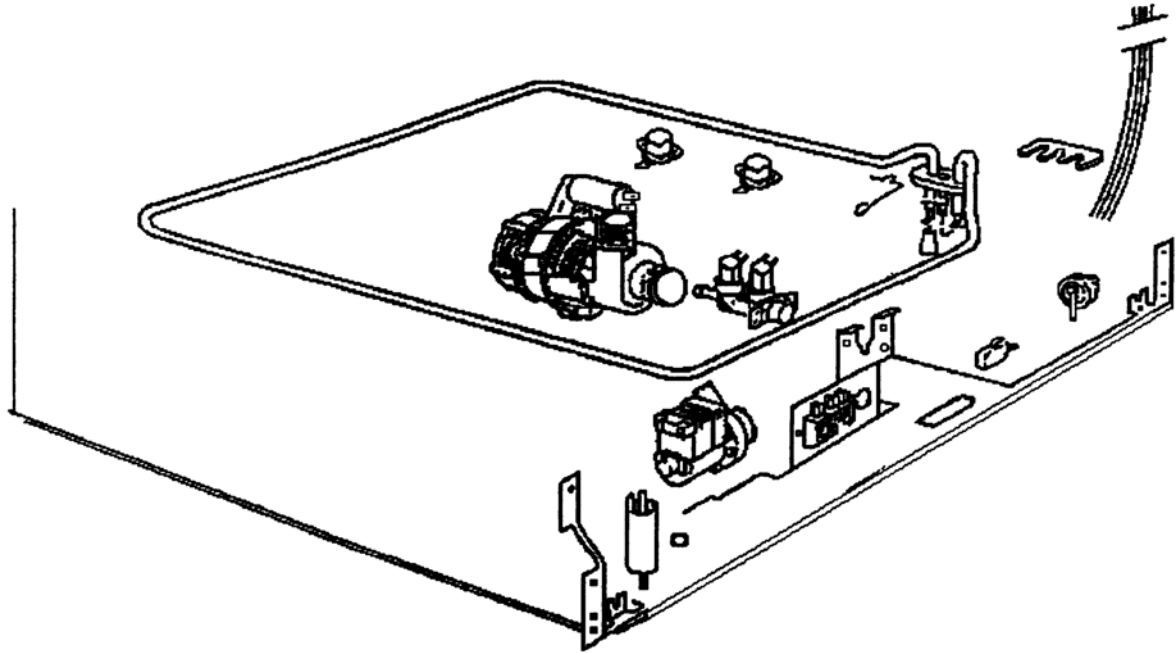

ELECTRICAL EQUIPMENT

- | | |
|------------------------|--------------------------|
| 1. Heating Element | 6. Outlet Pump |
| 2. Circulation Pump | 7. RFI Filter |
| 3. Thermostat (T2) | 8. Terminal Box |
| 4. Overload Protection | 9. Overflow Micro-Switch |
| 5. Inlet Valve | 10. Leveling Switch |

INTERIOR LIGHT

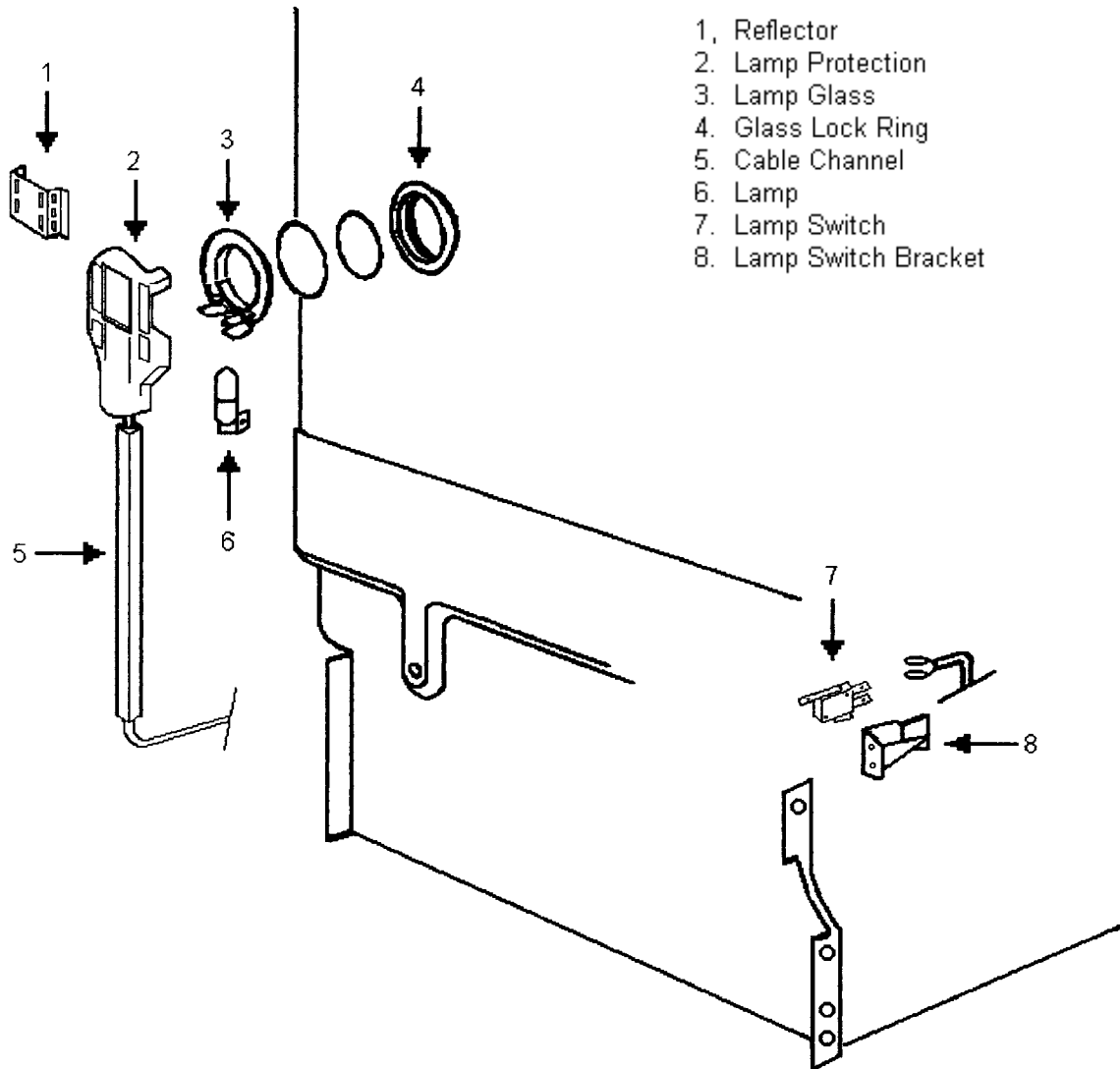

DOOR PANEL REMOVAL

1. Remove control knobs
2. Remove 2 screws (D) from the bottom of the door.
3. Remove 3 screws (B) from each side of the door liner.
4. Remove 2 screws © from the door latch.
5. Remove 4 screws (A) that hold the timer and the temperature controls to the outer door panel.

Note:

- The screws on the bottom of the door are plastic screws (large thread).
- All screws exposed to water will be Stainless Steel (Will Not Rust).

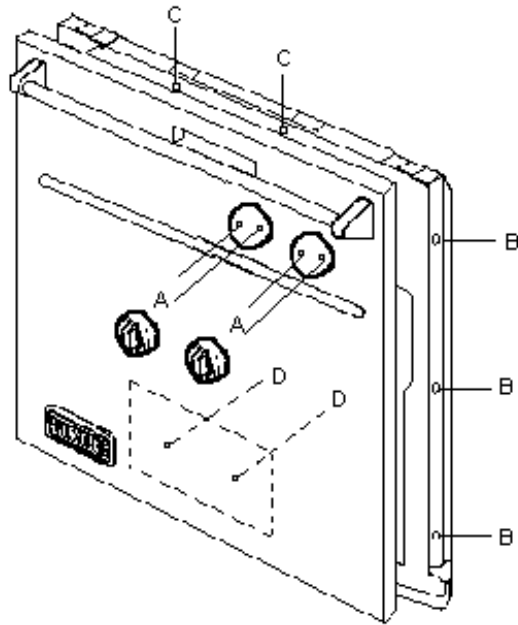

To remove the **DRAIN PUMP** rotate 1/4 turn clockwise.

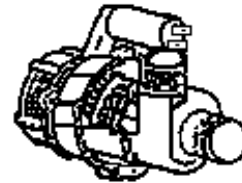

The **CIRCULATION PUMP** is mounted behind the well (sump).

- NOTE:** #1. You can use regular hose clamps on any hose except pressure hose connections.
#2. You can unclog the drain pump by removing the coarse strainer, then remove the Small cover in the bottom of the well. There you can reach the pump impeller and remove any obstruction in the pump.

The **PRESSURE SWITCH** will run for 30 seconds to try to correct an over fill water level. After 30 seconds the dishwasher will shut off leaving the water pump energized.

The **FOAM FLOAT** beneath the well (sump), lying on the bottom of the base pan, will turn the dishwasher off if there is an overflow. The drain pump will remain energized.