

Service

International Side by Side 1997 "T" Model Refrigerators

Refer to Technical Sheet
for values and wiring
schematics.

Models and manufacturing
numbers in this manual

SR520T	P1312901W
SB520T	P1313001W
SSD522T	P1313602W
SXD520T	P1313701W
SBDX520T	P1313202W
SSD522TB	P1313601W
SBDT520T	P1313201W
SRD520T	P1313101W
SRD522T	P1313301W
SRD526T	P1313401W
SRDE520T	P1312401W
SBDE520T	P1312301W
SRDE520TB	P1312402W
SRDE528T	P1312601W
SRDE528TB	P1312602W
SRD325S5	P1313501W
SRD327S3	P1312502W
SXD322	P1313901W
SRDE327S3	P1312501W
SX322S2	P1313801W

This manual is to be used by qualified appliance technicians only. Amana does not assume any responsibility for property damage or personal injury for improper service procedures done by an unqualified person.

Amana

RS5290000
Revision 0
April 1998

Important Information

Pride and workmanship go into every product to provide our customers with quality products. It is possible, however, that during its lifetime a product may require service. Products should be serviced only by a qualified service technician who is familiar with the safety procedures required in the repair and who is equipped with the proper tools, parts, testing instruments and the appropriate service manual. **REVIEW ALL SERVICE INFORMATION IN THE APPROPRIATE SERVICE MANUAL BEFORE BEGINNING REPAIRS.**

Important Notices for Consumers and Servicers



WARNING

To avoid risk of serious injury or death, repairs should not be attempted by an unauthorized personnel, dangerous conditions (such as exposure to electrical shock) may result.



CAUTION

Amana will not be responsible for any injury or property damage from improper service procedures. If performing service on your own product, assume responsibility for any personal injury or property damage which may result.

To locate an authorized servicer, please consult your telephone book or the dealer from whom you purchased this product. For further assistance, please contact:

CONSUMER AFFAIRS DEPT.
AMANA REFRIGERATION, INC.
AMANA, IOWA 52204

**OR
CALL**

1-319-622-5511 or (1-800-843-0304)
and ask for
Consumer Affairs

If outside the United States contact:

AMANA
ATTN: CONSUMER AFFAIRS DEPT.
AMANA, IOWA 52204, USA
Telephone: (319) 622-5511
Facsimile: (319) 622-2180
TELEX: 4330076 AMANA
CABLE: "AMANA", AMANA, IOWA, USA

Recognize Safety Symbols, Words, and Labels



DANGER

DANGER - Immediate hazards which **WILL** result in severe personal injury or death.



WARNING

WARNING - Hazards or unsafe practices which **COULD** result in severe personal injury or death.



CAUTION

CAUTION - Hazards or unsafe practices which **COULD** result in minor personal injury or product or property damage.

User Operation

Features

Fresh Food Section (Refrigerator)

1. Temp-Assure[®] Thermostatic Control
2. Spillsaver[®] Shelves
3. Slide Out Shelves
4. Chiller Fresh System
5. Garden Fresh Drawers
6. Utility Rack
7. Covered Utility Bucket
8. Dairy Center
9. Snack Chiller
10. Beverage Chiller
11. Door Buckets
12. Adjustable Divider

Deepfreeze[®] Section (Freezer)

13. Deepfreeze[®] Shelf
14. Automatic Ice Maker
15. Stor-Mor[®] System
16. Door Dike
17. Door Shelves
18. Tall Package Retainer
19. Ice 'N Water[®] Dispenser

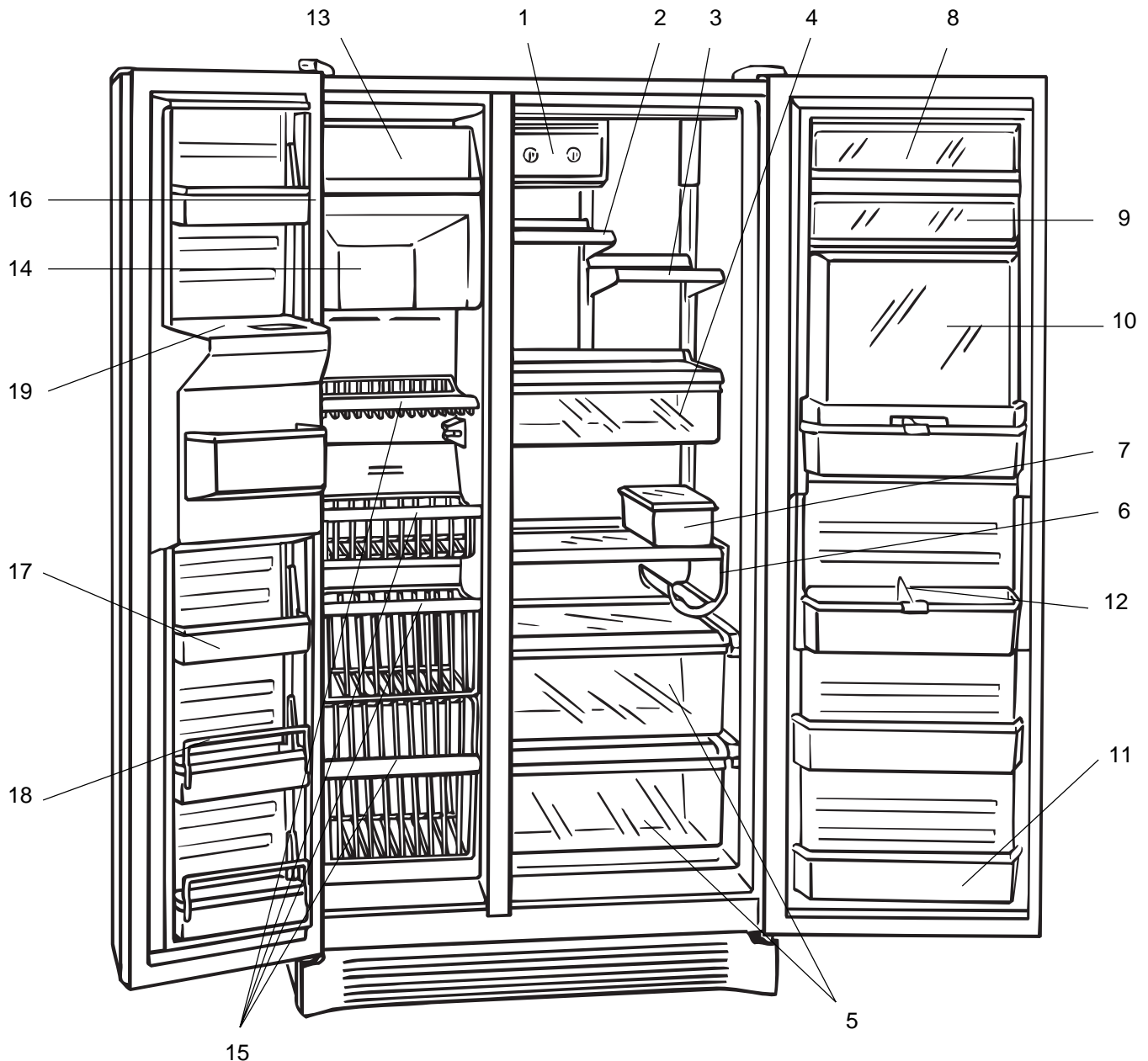

Features vary from model to model.

User Operation

Electrical Requirements

Refrigerator must be earthed and connected to a separate 230 volt, 50 hz., 10A circuit.

Model Identification

Locate product information on the nameplate, found in upper left corner of Fresh Food section. Record the following information: Model Number, Manufacturing Number, Serial or S/N Number, Date of purchase, Dealer's name and address.

Features

Spillsaver[®] Shelves



Caution

To avoid personal injury or property damage, handle tempered glass shelves carefully. Shelves may break suddenly if nicked, scratched or exposed to sudden temperature change.

1. Remove shelves by lifting front and releasing hooks from metal track.
2. Replace shelves by inserting hooks into metal track and lowering front.

Chiller Fresh System

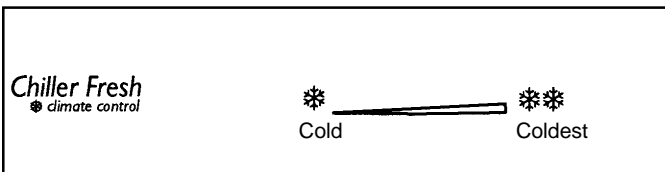

Locate control on front trim to adjust amount of air circulating between drawer and sleeve.

1. Remove drawer and sleeve by lifting and pulling out. Refer to "Spillsaver[®] Shelves" for instructions on removing and replacing shelf. Use eighth through eleventh slots.
2. Replace sleeve then drawer by sliding in. Confirm boot is over air inlet in side wall.

Garden Fresh Crispers

Locate control on front trim to adjust to either high or low settings.

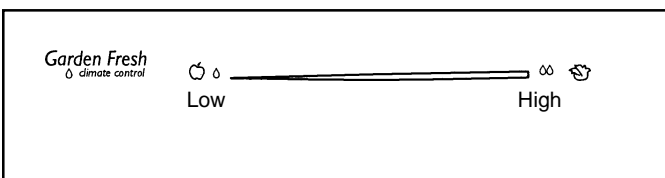

1. Remove drawers by lifting and pulling out. Refer to "Spillsaver[®] Shelves" for instructions on removing and replacing shelf.
2. Replace drawers by sliding in.

Dairy Center

1. Remove door by opening door, pushing in slightly near hinges and pulling out.
2. Remove shelf by lifting and pulling out.
3. Replace door and shelf by reversing steps 1-2.

Snack Chiller

1. Remove door by opening door, pushing in slightly near hinges and pulling out.
2. Remove bucket by removing Beverage Chiller door then lifting bucket.
3. Replace door and bucket by reversing steps 1-2.

Beverage Chiller

Locate control dial on left front wall of Fresh Food section to adjust amount of air.

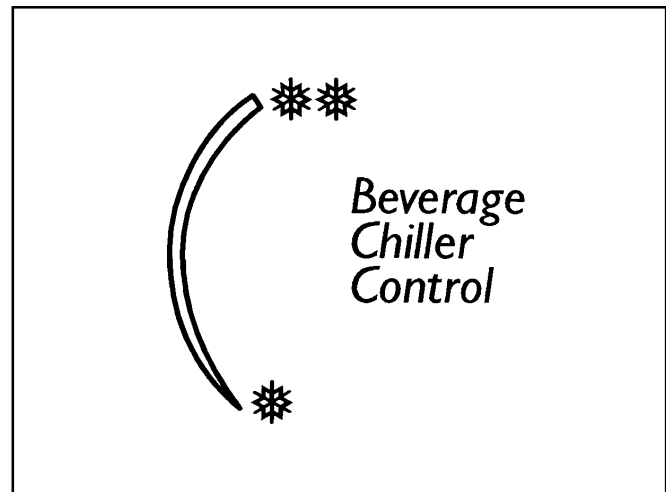

1. Remove beverage chiller door by removing lower door buckets. Slide chiller door down and out through bottom of door track.
2. Replace beverage chiller door by reversing step 1. Retention glides must remain in place to install door.

Door Buckets

1. Remove door buckets by pushing tabs toward center and pulling out.
2. Replace door buckets by sliding in until tabs lock into place.

Door Shelves

1. Remove slide-style door shelves by lifting and pulling out.
2. Replace slide-style door shelves by reversing step 1.
1. Remove hook-style door shelves by tapping up each end. Lift bottom of shelf release hooks.
2. Replace hook-style shelves by inserting hooks and lowering bottom of shelf. Tap down on ends.

User Operation

Stor-Mor[®] System

1. Remove shelves and baskets by lifting and pulling out.
2. Replace shelves and baskets by reversing step 1.

Door Dike

1. Remove door dike by pulling forward and snapping out.
2. Replace door dike by aligning clips with holes on Deepfreeze[®] door. Push until dike locks in place.

Setting Controls

This refrigerator operates most efficiently in normal household temperatures of 12° to 43°C.

Fresh Food and Deepfreeze[®] Controls (nonelectronic models)

Locate Fresh Food and Deepfreeze[®] controls on upper rear wall of Fresh Food section. When Deepfreeze[®] control is set to *off*, neither Fresh Food nor Deepfreeze[®] sections will cool. Initially, set both controls to 4. Wait 24 hours for Fresh Food and Deepfreeze[®] sections to reach desired temperatures. After 24 hours, adjust controls as desired. 1 is warmest setting and 7 is coldest.

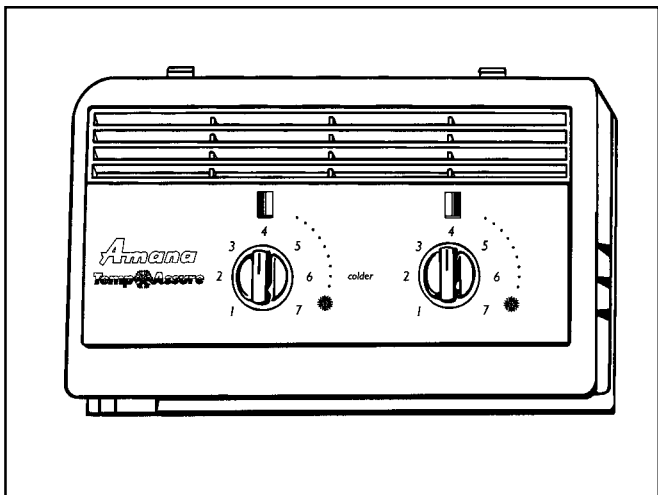

Set temperatures precisely using a household thermometer that includes temperatures between -20.5° to 10°C.

Put thermometer snugly between frozen packages in Deepfreeze[®] section. Wait 5-8 hours. If Deepfreeze[®] temperature is not -18° to -17°C, adjust control, one number at a time. Check again after 5-8 hours.

Put thermometer in a glass of water in middle of Fresh Food section. Wait 5-8 hours. If Fresh Food temperature is not 3° to 4°C, adjust control, one number at a time. Check again after 5-8 hours.

Touchmatic[®] Electronic Controls (electronic models)

Confirm power switch is on before programming. Remove toe grille and locate black box in center of cabinet. Power switch is on right side of box.

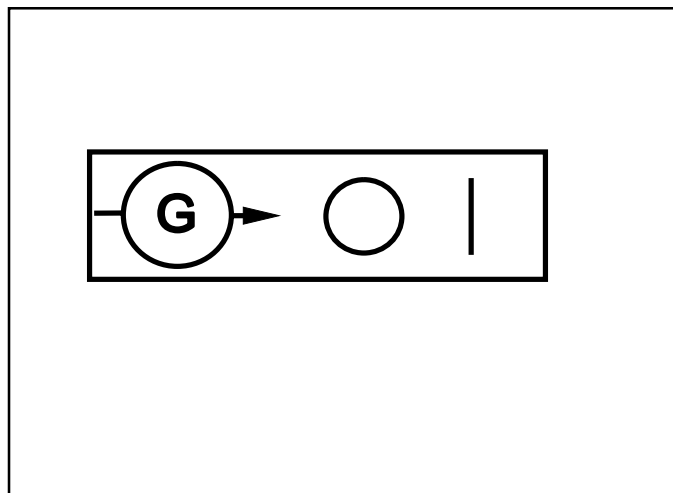

User Operation

Locate Touchmatic® electronic control panel on refrigerator between handles. Press * pad to activate control panel. All other pads, except for Alarm Off pad, remain inactive until * pad is pressed. Once activated, pads remain programmable for at least 10 minutes.

Fresh Food and Deepfreeze® controls are preset at 5. Wait 24 hours for Fresh Food and Deepfreeze® sections to reach desired temperatures. After 24 hours, adjust controls as desired. 1 is warmest setting and 9 is coldest. Refer to instructions on page 6 to set temperatures precisely.

Adjust Fresh Food or Deepfreeze® temperatures by pressing * pad then Fresh Food Temp pad or Deepfreeze® Temp pad. Press Warmer pad or Colder pad to adjust temperature setting one level at a time. Holding down Warmer pad or Colder pad adjusts temperature more than one level at a time.

Vacation Mode

Vacation mode defrosts refrigerator less often during extended non-use periods. Activate vacation mode by pressing * pad then Vacation pad. Indicator light will glow. Repeat above to deactivate vacation mode. Opening Fresh Food or Deepfreeze® door will also deactivate vacation mode.

Max Cool Mode

Max cool mode adjusts Fresh Food temperature to coldest setting. After 10 hours, Fresh Food temperature automatically returns to previous setting. Activate max cool mode by pressing * pad then Max Cool pad. Indicator light will glow. Repeat above to deactivate max cool mode before automatic reset.

Fast Freeze Mode

Fast freeze mode adjusts Deepfreeze® temperature to coldest setting. After 24 hours, Deepfreeze® temperature automatically returns to previous setting. Activate fast freeze mode by pressing * pad then Fast Frz pad. Indicator light will glow. Repeat above to deactivate fast freeze mode before automatic reset.

Entry Tone

Entry tone indicates a pad was pressed and command was read and accepted. Deactivate entry tone by pressing and holding * pad for three to five seconds. Three short beeps indicate instructions were accepted. Repeat above to activate entry tone.

Door Open Alarm

Door open alarm sounds and glowing indicator light blinks if either door is open for three minutes. Deactivate door open alarm by pressing Alarm Off pad or by closing either door. Activate door open alarm by pressing * pad then holding Alarm Off pad for three to five seconds. Three short beeps will sound. Repeat above to deactivate door open alarm indefinitely.

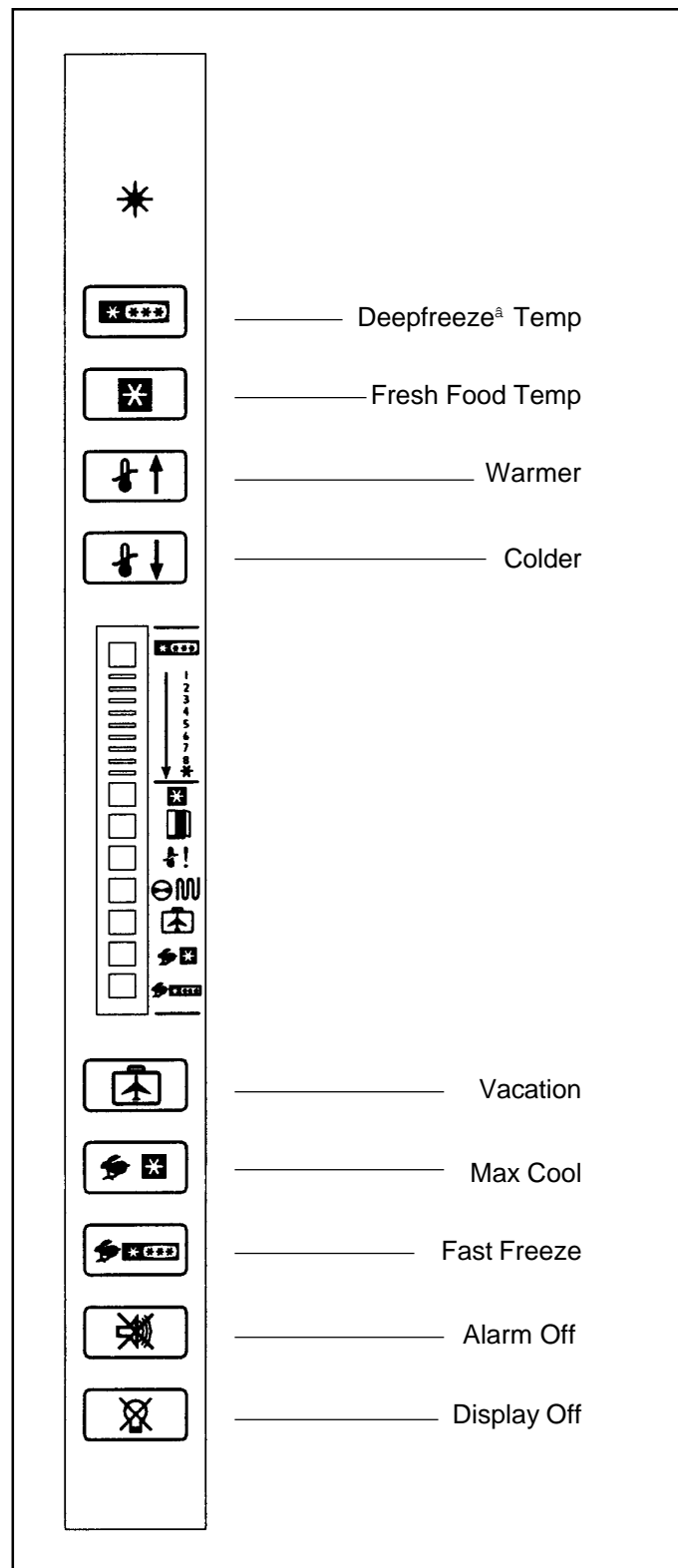

User Operation

High Temperature Alarm

High temperature alarm sounds and indicator light glows if Fresh Food or Deepfreeze® temperature is high for two hours. A blinking light signals affected compartment. Deactivate high temperature alarm by pressing Alarm Off pad. Alarm discontinues when proper temperature is reached.

Thermistor Alarm

Thermistor alarm sounds and indicator lights scroll if Fresh Food or Deepfreeze® thermistor is not operating properly. Deactivate display by pressing Alarm Off pad.

If thermistor alarm sounds, contact an authorized servicer immediately. If Alarm Off pad is pressed, thermistor control retests to confirm situation has been corrected. Alarm sounds again if thermistor is still not operating properly.

Display Lights

Deactivate temperature display lights by pressing ✱ pad then pressing Display Off pad. Activate temperature display lights by pressing any of top five pads.

Clean Condenser Coil Light

Clean condenser coil light glows once every three months as a reminder to clean condenser coil. Light automatically cancels in 72 hours. Deactivate clean condenser coil light before automatic reset by pressing Alarm Off pad.

Automatic Ice Maker

Refrigerator has an electrical connection in Deepfreeze® section for ice maker installation. Ice maker, model IC54, and water filter, part #R0183114, can be purchased separately.

1. Confirm ice storage bucket is in place and ice maker arm is down.
2. After Deepfreeze® section reaches normal temperature, ice maker fills with water and begins operating. Allow 24-48 hours after installation before first harvest of ice. Ice maker produces seven to nine harvests of ice in a 24-hour period under ideal conditions.
3. After ice is formed, ice maker drops ice cubes into ice storage bucket. During ice production, ice maker arm raises and lowers. When ice storage bucket is full, ice maker arm turns ice maker off.

Important: Discard first three harvests of ice so any impurities are not consumed.

4. Stop ice maker by lifting ice maker arm. A definite click will be heard when proper position is reached. Ice maker arm will remain in that position.

Important: Do not force ice maker arm down or up past stop position.

Ice 'N Water[®] Dispenser

Caution

To avoid personal injury or property damage, observe following instructions:

1. Do not operate dispenser with Deepfreeze® door open.
2. Do not put fingers, hands, or any foreign object into dispenser opening.
3. Do not use sharp objects to break ice.

Water Dispenser Operation

1. Dispense water by pressing container against water dispenser bar.
2. Shut off water by releasing pressure on bar. Slight dripping may occur. Spill shelf is not self-draining. Large spills should be wiped dry immediately.

Ice Dispenser Operation

1. Select cubed or crushed mode (some models) by sliding lever on dispenser panel. Dispense ice by pressing wide mouthed container against ice dispenser bar. Hold container close to chute to minimize spraying ice.

Caution

To avoid property damage, do not dispense ice directly into thin glass, fine china or delicate crystal.

2. Shut off ice by releasing pressure on bar before container is full. Some ice will continue to fall. Do not remove container until last of ice falls.

If dispensing ice continuously, dispenser motor shuts off after approximately two minutes. Motor resets after three minutes and dispensing can continue.

A slight delay occurs when switching between cubed and crushed modes. Pieces of crushed ice will vary in size and shape. "Snow" may form on door and ice chute when repeatedly dispensing crushed ice. Allow "snow" to evaporate or wipe dry.

Dispenser operates only with cubes of proper size and crescent shape. Do not add purchased ice cubes or other cubes.

Dispenser Light

A light is activated when dispensing ice or water. Some models feature a night light. Deactivate night light by pushing switch, located underneath dispenser facade and left of ice dispenser bar.

User Operation

Water Taste and Odor

Observe the following to minimize taste and odor difficulties:

1. Throw away first 10 to 14 regular glasses of water after initially connecting refrigerator to household water supply.
2. Flush water system and reservoir as above after extended periods of non-use.
3. Wrap foods in tightly sealed containers or moisture proof bags.
4. Install water filter, part #R0183114 on water line.
5. Contact local water treatment company for specialized help if difficulties persist.

Care and Cleaning

WARNING

To avoid electrical shock which can cause severe personal injury or death, disconnect power to refrigerator before cleaning. After cleaning, reconnect power.

Caution

To avoid personal injury or property damage, read and follow all cleaning product manufacturer's directions.

General

1. Wash surfaces with four tablespoons baking soda diluted in one quart warm water as needed. Rinse and dry surfaces thoroughly.
2. Do not use the following items:
 - abrasive cleaners such as ammonia, chlorine bleach, etc.
 - solvents
 - metal scouring pads

These items can scratch, crack and discolor surfaces.

Glass Shelves

Caution

To avoid personal injury or property damage, handle tempered glass shelves carefully. Shelves may break suddenly if nicked, scratched or exposed to sudden temperature change.

Remove glass shelf and place on a towel. Allow shelf to adjust to room temperature before cleaning.

Light Bulbs

WARNING

To avoid electrical shock which can cause severe personal injury or death, disconnect power to refrigerator before replacing light bulb. After replacing light bulb, reconnect power.

Caution

To avoid personal injury or property damage, observe the following:

1. Allow bulb to cool.
2. Wear gloves when replacing light bulb.

Remove light bulb cover. Replace light bulb with same size and type of appliance bulb.

Door Gaskets

1. Clean door gaskets every three months or according to "General" cleaning instructions.
2. Rinse and dry gaskets thoroughly.
3. Apply a light film of petroleum jelly to keep door gaskets pliable.

Condenser Coil

Clean condenser coil every three months.

Accumulated dust and lint may cause the following:

- reduced cooling performance
- increased energy usage
- premature part failure

1. Remove toe grille by pulling forward.
2. Clean coil with a vacuum cleaner hose nozzle.
3. Install toe grille by positioning top and snapping in bottom. Top is indicated on back of toe grille.
4. Pull refrigerator away from wall. Run a vacuum brush across condenser fan outlet grille on back of refrigerator.

User Operation

Vacation Tips

For short vacations, remove perishable foods. If an ice maker is installed, move ice maker arm to off position.

For long vacations, do the following:

1. Remove food from refrigerator.
2. Unplug refrigerator.
3. Clean refrigerator.
4. Clean door gaskets.
5. Prop doors open, so air can circulate inside.
6. Turn off water supply to refrigerator if an ice maker is installed and move ice maker arm to off position.



Caution

To avoid property damage, turn off water supply to refrigerator and move ice maker arm to off position before leaving on vacation.

Normal Operating Sounds

This new refrigerator may be replacing a differently designed, less efficient or smaller refrigerator. Today's refrigerators have new features and are more energy efficient. As a result, certain sounds may be unfamiliar. These sounds are normal and will soon become familiar. These sounds also indicate refrigerator is operating and performing as designed.

Electronic Control Models

Evaporator fan does not operate when either Fresh Food or Deepfreeze® door is open.

Before Calling For Service

Refrigerator does not operate.

- Confirm Deepfreeze® control is on.
- Confirm electrical power cord is plugged in.
- Check fuse or circuit breaker. Plug in another item at that wall outlet.
- Wait 40 minutes to see if refrigerator restarts. If Deepfreeze® control is on and lights work but two fans and compressor are not operating, refrigerator may be in defrost cycle.

Refrigerator still won't operate.

- Unplug refrigerator. Transfer food to another unit or place dry ice in Deepfreeze® section to preserve food until refrigerator can be serviced.

Food temperature appears too warm.

- See above sections.
- Allow adequate time for food to reach Fresh Food or Deepfreeze® temperature if a large supply of food was recently added.
- Clean condenser coil.
- Adjust Fresh Food and/or Deepfreeze® control.
- Confirm rear air grille is not blocked. Rear air grille is located behind left crisper.

Chiller fresh system is too warm.

- Slide control to a colder setting.
- Adjust Deepfreeze® control to a colder setting.

Food temperature is too cold.

- Clean condenser coil.
- Adjust Fresh Food control.
- Allow several hours for temperature to adjust.

Refrigerator runs too frequently.

- It may be normal to maintain an even temperature.
- Doors may have been opened frequently or for an extended period of time.
- Clean condenser coil.
- Adjust Deepfreeze® control.
- Check gasket for proper seal.

Water droplets form on inside of refrigerator.

- This is normal during periods of high humidity or if doors have been opened frequently.

Water droplets form on outside of refrigerator.

- Check gasket for proper seal.

Crisper drawers or chiller fresh system do not close freely.

- Check for a package which may prevent drawers from closing properly.
- Confirm drawers are in proper position.
- Clean drawer channels with warm, soapy water. Rinse and dry thoroughly.
- Apply a thin layer of petroleum jelly to drawer channels.
- Confirm refrigerator is level.

Refrigerator has an odor.

- Clean inside of Fresh Food and Deepfreeze® sections.
- Cover all foods tightly and use freezer wrap.

Ice cubes have an odor.

- See above section.
- Discard ice and clean ice bucket or trays more frequently. Ice cubes are very porous and absorb odors very easily.

Refrigerator or ice maker make unfamiliar sounds or seems too loud.

- See "Normal Operating Sounds" section. These may be normal.

Ice cubes stick together or 'shrink'.

- Empty ice cube bucket or trays more frequently. If used infrequently, ice cubes may stick together or shrink.

Ice forms in inlet tube to ice maker.

- Check water pressure. Low water pressure will cause valve to leak. Self-piercing valves cause low water pressure. **Do not use self-piercing valves.**

Installation Instructions

International Side-by-Side Installation Instructions

Introduction

A qualified engineer must connect refrigerator in accordance with these installation instructions. Measure door opening and depth and width of refrigerator. Remove handles or doors as required. Engineer must also do the following:

1. Follow local water and electrical company connection regulations.
2. Complete water supply connection before electrical supply connection.



RECOGNIZE THIS SYMBOL AS A SAFETY PRECAUTION

Installation Requirements

1. Install on an earthed outlet with a separate 230 volt, 50 hz., 10A circuit.
2. Protect soft flooring with cardboard or rugs.
3. Install on a floor which supports up to 429 kg.
4. Provide 25 mm clearance on top and 5 mm on sides of refrigerator.
5. **20 cubic foot Models**
Trim corners of counter top to a 45° angle if counter top has 25 mm overhang.

Removing Wooden Base



Caution

To avoid personal injury or property damage, two people must remove wooden base.

1. Tape doors shut to prevent doors from opening unexpectedly.
2. Slide appliance cart under side of refrigerator.
3. Wrap refrigerator with blanket or pad. Thread strap around refrigerator. Put foam shipping pads, located in shipping carton, under strap. Tighten strap securely.
4. Lower appliance cart to floor with appliance cart handles on bottom.
5. Remove top two bolts from skid.
6. Return refrigerator and appliance cart to an upright position. Remove strap.
7. Slide appliance cart under opposite side of refrigerator.
8. Repeat steps 3-5.
9. Remove wooden base.
10. Return refrigerator and appliance cart to an upright position and remove appliance cart.

Important: Do not leave refrigerator on its side longer than necessary to remove bolts.

Removing Handles



Caution

To avoid personal injury or property damage, hold handles securely while removing.

1. Nonextruded Handle Models

Remove top end cap. Remove door handle insert by pulling up.

Extruded Handle Models

Remove trim using putty knife covered with tape.

2. Remove door handles by removing screws.

Electronic Control Models

Remove electronic control panel by carefully disconnecting ribbon cable from socket.

3. Install door handles by reversing steps 1-2.

Removing Doors



Caution

To avoid personal injury or property damage, two people must remove and hang doors.

1. Tape doors shut to prevent doors from opening unexpectedly.
2. **Nonextruded Handle Models**
Remove top door trim. Leave spacer in place and slide trim away from end caps. Remove top hinge covers.
Ice 'N Water[®] Dispensing Models
Remove top hinge covers.
All Other Models
Remove top hinge cover by lifting back and sliding forward.
3. Remove toe grille by lifting and pulling forward.

Installation Instructions

4. Electronic Control Models

Remove bottom door closure screw. Unplug wiring harness from high voltage box under refrigerator. Unplug top hinge wire connectors. Unscrew green/yellow earthing wire.

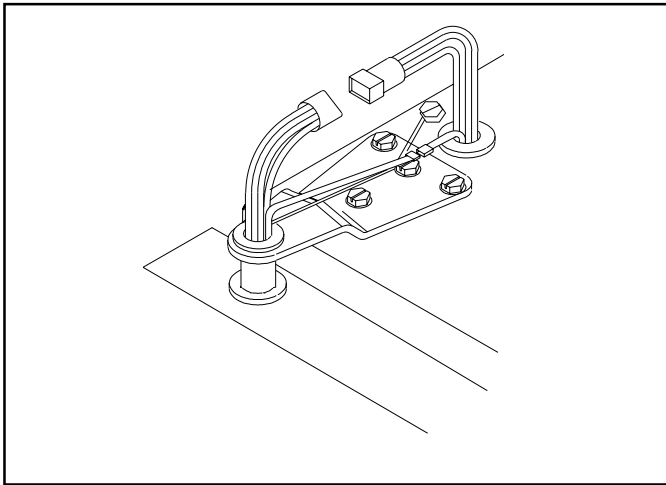

5. Remove top Fresh Food hinge by removing screws.
6. Remove tape from Fresh Food door while holding door securely.
7. Remove Fresh Food door by lifting while opening.

Electronic Control Models

Slide wiring harness through slot in bottom door hinge bracket as door is raised.

Removing Handles



Caution

To avoid personal injury or property damage, hold handles securely while removing.

1. Nonextruded Handle Models

Remove top end cap. Remove door handle insert by pulling up.

Extruded Handle Models

Remove trim using putty knife covered with tape.

2. Remove door handles by removing screws.

Electronic Control Models

Remove electronic control panel by carefully disconnecting ribbon cable from socket.

3. Install door handles by reversing steps 1-2.

Removing Doors



Caution

To avoid personal injury or property damage, two people must remove and hang doors.

1. Tape doors shut to prevent doors from opening unexpectedly.
2. **Nonextruded Handle Models**
Remove top door trim. Leave spacer in place and slide trim away from end caps. Remove top hinge covers.

Ice 'N Water^a Dispensing Models

Remove top hinge covers.

All Other Models

Remove top hinge cover by lifting back and sliding forward.

3. Remove toe grille by lifting and pulling forward.
4. **Electronic Control Models**

Remove bottom door closure screw. Unplug wiring harness from high voltage box under refrigerator. Unplug top hinge wire connectors. Unscrew green/yellow earthing wire.

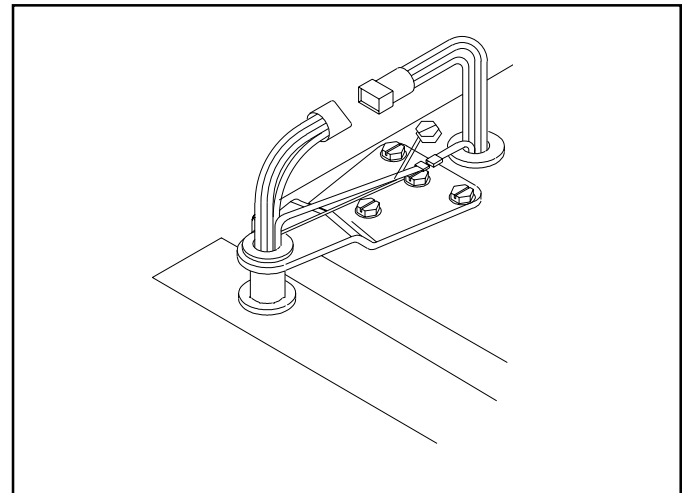

5. Remove top Fresh Food hinge by removing screws.
6. Remove tape from Fresh Food door while holding door securely.
7. Remove Fresh Food door by lifting while opening.

Electronic Control Models

Slide wiring harness through slot in bottom door hinge bracket as door is raised.

Installation Instructions

8. Ice 'N Water[®] Dispensing Models

Loosen screw from water tube clamp. Loosen 6.4 mm plastic water tube union nut by hand. Pull water tube away from union nut and through tube clamp. Unplug top hinge wire connectors.

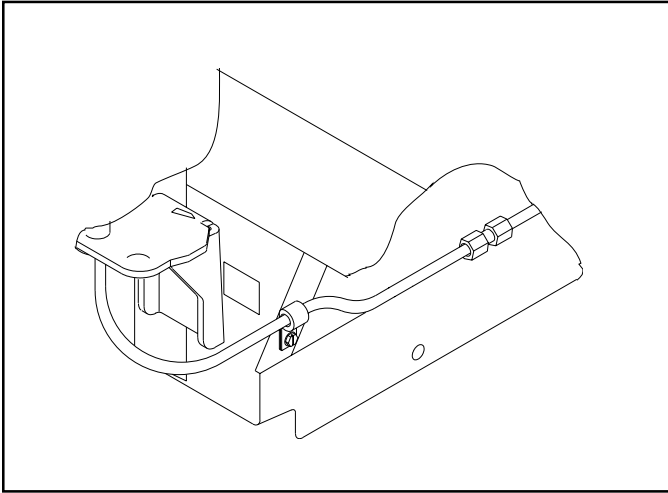

WARNING

To avoid electrical shock which can cause severe personal injury or death, green/yellow earthing wire must remain attached to hinge. Do not disassemble.

9. Remove top Deepfreeze[®] hinge by removing screws.
10. Remove tape from Deepfreeze[®] door while holding door securely.
11. Remove Deepfreeze[®] door by lifting while opening. This will free Deepfreeze[®] door from bottom hinge pin.

Ice 'N Water[®] Dispensing Models

Slide plastic water tube through slot in bottom door hinge as door is raised.

12. Remove bottom hinge by removing screws.
13. Install doors by reversing steps 1-12.

Connecting Water Supply

Materials Required

2.5 m of 6.4 mm flexible copper tubing

Important: Before installing ice maker, contact a plumber to connect copper tubing to household plumbing in compliance with local codes and ordinances. **Warranty will be void if installation is improper or a self-piercing valve is used.**

Procedure



Caution

To avoid property damage, observe the following:

1. Check for water leaks prior to returning refrigerator to normal location.
 2. Start tubing nuts by hand to avoid cross threading. Finish tightening nuts using an adjustable wrench. Do not overtighten.
 3. Check carefully for water leaks 24 hours after installation.
1. Turn off water supply to refrigerator.
 2. Seal open end of copper tubing with tape.
 3. Route copper tubing up to refrigerator. Copper tubing route must be above 2°C to prevent water line from freezing.
 4. Remove masking tape from end of copper tubing.
 5. Put other end of copper tubing into bucket. Turn on water supply to refrigerator. Water will be under considerable pressure. Allow water to run through copper tubing. Turn off water supply to refrigerator when flushing is complete.
 6. Remove and retain lower cover by removing screws.

Installation Instructions

7. Assemble water valve coupling by removing nut and sleeve from adapter fitting. Slide brass nut and sleeve over end of copper tubing. Insert copper tubing completely into adapter fitting.

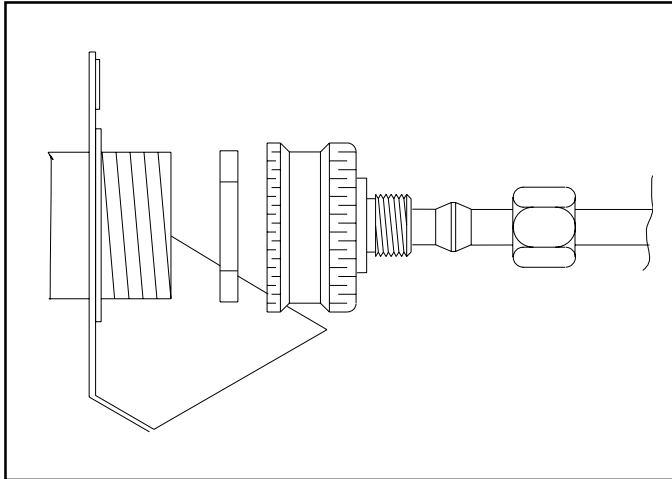

8. Confirm hose washer is in place by checking fitting. Tighten adapter fitting by hand. Tighten an additional 1/2 turn. Connect nut on copper tubing to adapter fitting. Confirm copper tubing is secure by pulling on copper tubing.
9. Turn on water supply to refrigerator and check for leaks. Turn off water supply to refrigerator and correct leaks. Repeat this process until no leaks are found, then completely turn on water supply to refrigerator.
10. Install lower back cover by reversing step 6. Tuck wires inside cover. Avoid pinching wires.
11. Create service loop avoiding kinks. **Secure copper tubing at back horizontal cover using "P" clamp.**



Caution

To avoid property damage, all covers must be in place.

Leveling Refrigerator

1. Place level side-to-side at top front of refrigerator.
2. Remove toe grille by lifting and pulling forward.

Important

Some models have both front and rear leveling legs.

3. Adjust leveling wheels by rotating leveling screws. Raise refrigerator by rotating leveling screws clockwise.
4. **Models with Hinge Adjusting Cam**
If tops of doors are not aligned, loosen refrigerator door hinge screws 1/2 turn. Turn cam clockwise 1 increment at a time until doors are aligned. Open and close doors. Tighten hinge screws.

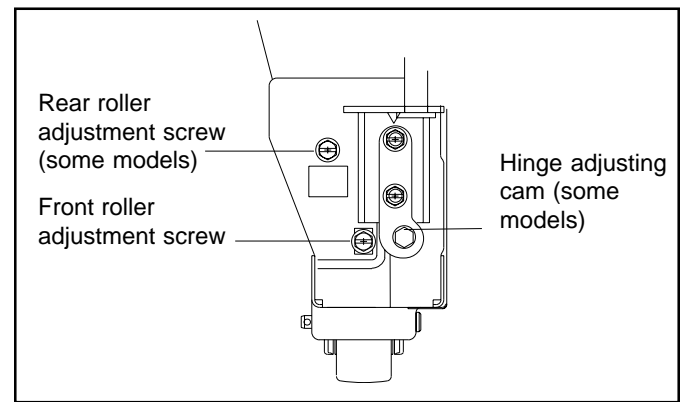

5. Install toe grille by positioning top and snapping in bottom. Top is indicated on back of toe grille.

Troubleshooting Chart



WARNING

To avoid risk of electrical shock, personal injury, or death, disconnect electrical power source to unit and discharge capacitor through a 10,000 ohm resistor before attempting to service, unless test procedures require power to be connected. Ensure all earthing wires are connected before certifying unit as repaired and/or operational.

Troubleshooting chart on following pages contains symptoms that may be seen in malfunctioning units. Each symptom is accompanied by one or more possible causes and by a possible remedy or test to determine if components are working properly.

Symptom	Possible Causes	Corrective Action
Unit does not run	No power to unit.	Check for power at outlet. Check fuse box/circuit breaker for blown fuse or tripped breaker. Replace or reset.
	Power switch shut off or faulty.	Check switch at high voltage board (electronic models only).
	Faulty service cord	Check with test light at unit; if no circuit and current is indicated at outlet, replace or repair.
	Low voltage	Check input voltage for proper voltage. Take appropriate action to correct voltage supply problem.
	Faulty motor or freezer temperature control	Check all connections are tight and secure. Jumper across terminals of control. If unit runs, replace control.
	Faulty timer	Check with test light. Replace if necessary.
	Faulty high voltage board compressor/condenser fan relay	Check relay. Replace if necessary.
	Faulty compressor	Check compressor motor windings for opens/shorts. Perform compressor direct wiring test. Replace is necessary.
	Faulty overload	Check overload for continuity. Note: Ensure compressor/overload are below trip temperature before testing. Replace if necessary.
Refrigerator section too warm	Excessive door opening	Consumer education
	Overloading of shelves	Consumer education
	Warm or hot foods placed in cabinet	Consumer education
	Refrigerator temperature control set too warm	Set control to colder setting.
	Poor door seal	Level cabinet. Adjust hinges. Replace gasket.
	Refrigerator airflow	Check damper is opening by removing grille. With door open, damper should open. Replace if faulty. Turn control knob to colder position. Check airflow fan. Replace if faulty.
	Interior light remains on	Check switch. Replace if necessary.
	Faulty condenser fan or evaporator fan	Check fan switch, fan, and wiring. Replace if necessary
	Faulty compressor	Replace compressor.

Troubleshooting Chart



WARNING

To avoid risk of electrical shock, personal injury, or death, disconnect electrical power source to unit and discharge capacitor through a 10,000 ohm resistor before attempting to service, unless test procedures require power to be connected. Ensure all earthing wires are connected before certifying unit as repaired and/or operational.

Symptom	Possible Causes	Corrective Action
Refrigerator section too cold	Refrigerator temperature control set too cold	Adjust refrigerator temperature control
	Refrigerator airflow not properly adjusted	Adjust airflow grille to freezer. Adjust Beverage chiller and Chiller Fresh temperature controls.
Freezer and refrigerator sections too warm	Temperature controls set too warm	Reset temperature controls.
	Poor door seal	Level cabinet. Adjust hinges. Replace gasket.
	Dirty condenser or obstructed grille	Check condenser and grille. Clean.
	Faulty control	Test control. Replace if defective.
	Defrost heater remains open	Check evaporator.
	Refrigerant shortage or restriction	Check for leak or restriction. Repair, evacuate and recharge system.
Freezer section too cold	Freezer temp control set too cold	Adjust freezer temperature control
	Faulty control	Test control. Replace if defective.
Unit runs continuously	Temperature control set too cold	Adjust temperature control.
	Dirty condenser or obstructed grille	Check condenser and grille. Clean.
	Poor door seal	Level cabinet. Adjust hinges. Replace gasket.
	Interior light remains on	Check switch. Check door activates switch. Adjust or replace if switch.
	Faulty condenser fan or evaporator fan	Check fan switch, fan, and wiring. Replace if necessary
	Faulty control	Test control. Replace if defective.
	Refrigerant shortage or restriction	Check for leak or restriction. Repair, evacuate and recharge system.
	Refrigerant overcharge	Check for overcharge. Evacuate and recharge system
Air in system	Check for low side leak. Repair, evacuate and recharge system.	
Unit runs continuously. Temperature normal or warm.	Ice on evaporator	See "Ice on evaporator."
Unit runs continuously. Temperature too cold or too warm.	Faulty defrost thermostat	Check thermostat. Replace if necessary.
Noisy operation	Loose flooring or floor not firm	Repair floor or brace floor.
	Cabinet not level	Level cabinet.
	Tubing in contact with cabinet, other tubing, or other metal	Adjust tubing.
	Drain pan vibrating	Adjust drain pan.
	Fan hitting another part	Ensure fan properly aligned and all attaching hardware and brackets are tight and not worn. Tighten or replace.
	Worn fan motor bearings	Check motor for loss of lubricant or worn bearings. Replace if necessary.
	Compressor mounting grommets worn or missing. Mounting hardware loose or missing.	Tighten hardware. Replace grommets if necessary.
	Free or loose parts causing or allowing noise during operation	Inspect unit for parts that may have worked free or loose or missing screws. Repair as required.

Troubleshooting Chart



WARNING

To avoid risk of electrical shock, personal injury, or death, disconnect electrical power source to unit and discharge capacitor through a 10,000 ohm resistor before attempting to service, unless test procedures require power to be connected. Ensure all earthing wires are connected before certifying unit as repaired and/or operational.

Symptom	Possible Causes	Corrective Action
Frost or ice on evaporator	Defrost thermostat faulty	Check defrost thermostat. Replace if defective.
	Evaporator fan faulty	Check fan motor. Replace if defective.
	Defrost heater remains open	Check defrost heater continuity. Replace if faulty.
	Defrost timer faulty	Check timer and replace if defective.
	Open wire or connector	Check wiring and connections. Repair as necessary.
	Refrigerant shortage or restriction	Check for leak or restriction. Repair, evacuate and recharge system.
Unit starts and stops frequently (cycles on and off)	Loose wire or thermostat connections	Check wiring and connections. Repair as necessary.
	Supply voltage out of specification	Check input voltage. Correct any supply problems.
	Overload protector open	Check overload protector for continuity. If open, replace overload. Note: Ensure overload/compressor are below trip temperature before testing.
	Faulty compressor motor capacitor	Check capacitor for open/short. Replace if necessary. Note: Discharge capacitor before testing.
	Restricted condenser air flow	Check condenser and grille for dirt. Clean
	Refrigerant shortage or restriction	Check for leak or restriction. Repair, evacuate and recharge system.

System Diagnosis

Pressure and Temperature Relationship Chart

See "Service Procedures" section for additional information about items in this chart.

Condition	Suction Pressure Variation from Normal	Head Pressure Variation from Normal	T1 Inlet Temperature Variation from Normal	T2 Outlet Temperature Variation from Normal	T3 Suction Temperature Variation from Normal	Wattage Variation from Normal
Refrigerant Overcharge	Increase	Increase	Warmer	Warmer	Colder	Increase
Refrigerant Shortage	Decrease	Decrease or Increase (Restriction Symptoms)	Colder	Warmer	Warmer	Decrease
Partial Restriction	Decrease	Decrease or Increase (Restriction Symptoms)	Colder	Warmer	Warmer	Decrease
Air in system	Near Normal	Increase	Warmer	Warmer	Warmer	Increase
Low Ambient Installation (Reverse from High Ambient Installation)	Decrease	Decrease	Colder	Warmer	Warmer	Decrease
Additional Heat Load	Increase	Increase	Warmer	Warmer	Warmer	Increase
Inefficient Compressor	Increase	Normal or Decrease	Warmer or Colder	Warmer	Warmer	Decrease

Display Panel

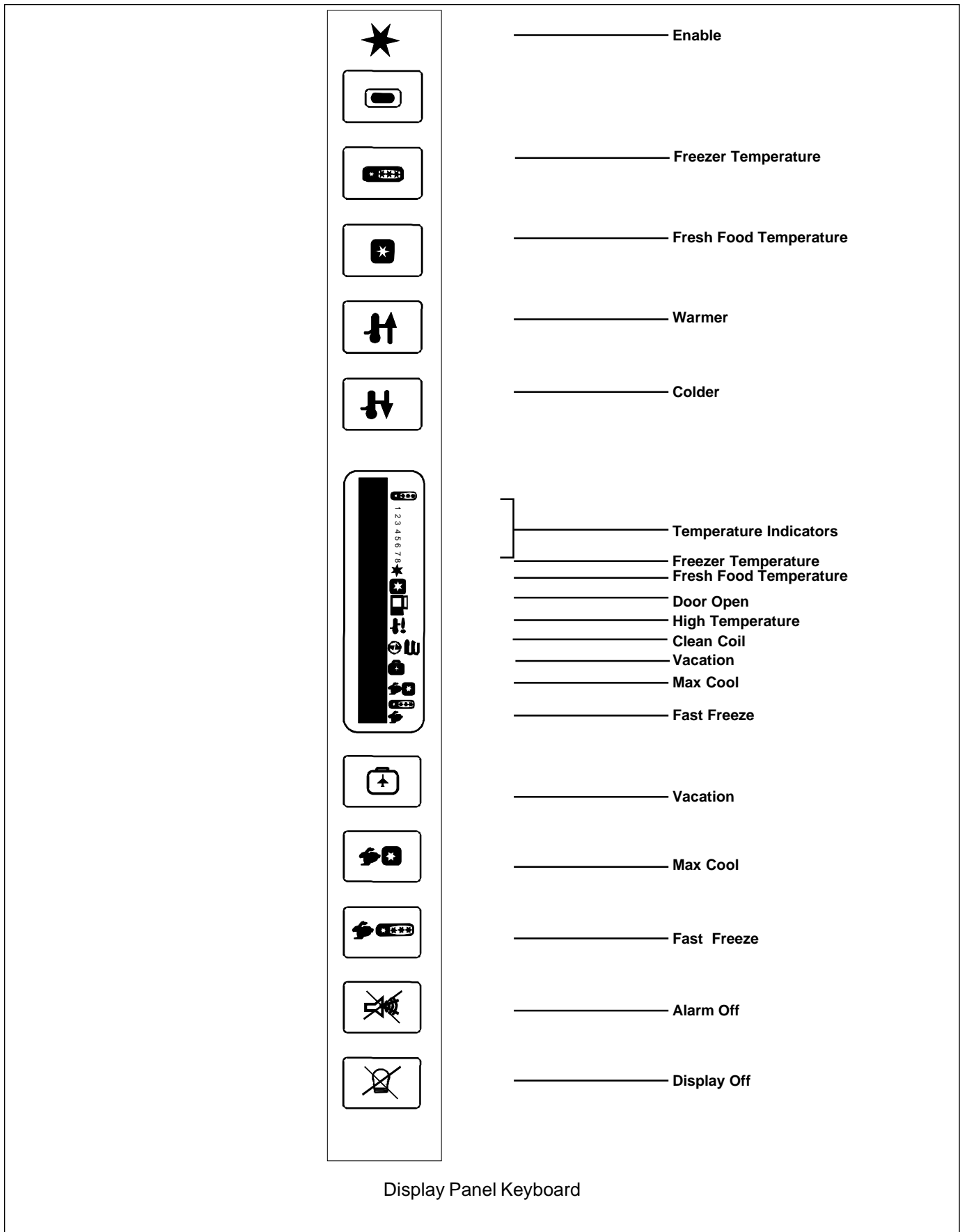

Display Panel Keyboard

Display Panel Operation

Keyboard Pad Functions

Entry Tone

Indicates a pad was pressed, command read and accepted. Turn off entry tone by pressing and holding * pad for 3 to 5 seconds.

Command Accepted Tone

Three short tones indicate command accepted.

*

1. Activates control panel. Control panel remains active at least 10 minutes.
2. Turns off Power Up Alarm (flashing lights) after power is first plugged in or after power outage.

Note: All pads, except *Alarm Off*, are inactive until * is pressed.

Freezer Temp Pad

Activates freezer temperature setting mode.

1. Freezer indicator light will glow. Freezer temperature setting will be displayed. Factory setting is 5.
2. Change freezer temperature setting by pressing *Warmer* or *Colder* pad.

Ref Temp Pad

Activates refrigerator temperature setting mode.

1. Refrigerator indicator light will glow. Refrigerator temperature setting will be displayed. Factory setting is 5.
2. Change refrigerator temperature setting by pressing *Warmer* or *Colder* pad.

Warmer Pad

Raises temperature setting one bar at a time. If entry tone is on, tone will sound at each bar level until top level is reached.

1. Turn on temperature setting function of control panel by pressing * pad.
2. Press and hold *Warmer* pad to raise temperature setting at a faster rate.

Colder Pad

Lowers temperature setting one bar at a time. If entry tone is on, tone will sound at each bar level until bottom level is reached.

1. Turn on temperature setting function of control panel by pressing * pad.
2. Press and hold *Colder* pad to lower temperature setting at a faster rate.

Fast Freeze Pad

Activates Maximum freezer mode setting freezer temperature to coldest setting for 24 hours or until *Fast Freeze* pad is pressed again.

1. Fast Freeze indicator light will glow.
2. To adjust maximum freezer mode time refer to Program Mode B functions.

Max Cool Pad

Activates maximum refrigerator mode setting refrigerator to coldest setting for 10 hours or until *Max Cool* pad is pressed again.

1. Max Cool indicator light will glow.
2. To adjust maximum refrigerator time refer to Mode B functions.

Alarm Off Pad

Turns off alarm signals. See Alarms Section to interpret alarm signals.

1. Press and hold *Alarm Off* pad for 3 seconds to deactivate Door Open alarm. To reactivate Door Open alarm, press and hold *Alarm Off* pad for 3 seconds.
2. If *Alarm Off* pad is pressed and condition causing alarm is not corrected, alarm will reset.

Display Off Pad

1. Deactivates control panel.
2. Deactivates temperature indication area of control panel.

Program Mode

* activates Program Mode. See Program Mode section for description of functions available.

1. Open refrigerator door.
2. Press * pad.
3. Within 6 seconds press the following pads in this sequence: *Max Cool*, *Fast Freeze*, *Max Cool*, *Fast Freeze*.
4. Tone will sound 3 times and control will be in Program Mode A.

Vacation

Defrost unit less often during extended periods of non-use. To begin Vacation Mode

1. Press * pad.
2. Press *Vacation* pad.

To deactivate Vacation Mode, open either refrigerator or freezer door or press * and *Vacation* pad.

NOTE: See Adaptive Defrost section for more information on Vacation Mode.

Electronic Functional Description

Alarms

Power Up Alarm

After power is initially plugged in, after a power loss, or if power switch is turned off, all temperature indicator lights will flash until *Alarm Off* or * is pressed.

Note: All settings return to default factory settings.

Door Open Alarm

Alarm tone sounds and indicator lights blink if either refrigerator or freezer door is open more than 3 minutes.

1. Turn off Door Open alarm by pressing *Alarm Off* pad or by closing door.
2. Deactivate door open alarm by pressing * pad and then press and hold *Alarm Off* pad for 3 seconds.
3. Door alarm delay can be adjusted in Program Mode B.

High Temperature Alarm

Alarm sounds and indicator light shows if freezer or refrigerator temperature has gone above critical level and remained warm for 2 hours. Alarm tone stops if temperature decreases again.

1. Critical temperature for freezer is $-9^{\circ}\text{C}(+15^{\circ}\text{F})$; for refrigerator critical temperature is $+15.5^{\circ}\text{C}(+60^{\circ}\text{F})$.
2. Press *Alarm Off* pad to turn off alarm.

Thermistor Alarm

Alarm sounds and freezer or refrigerator indicator turns on and temperature indicators 4 through 7 flash in sequence if either thermistor circuit opens. Refer to Temperature Control Operation Section and Electronic Testing Section.

1. Press *Alarm Off* pad to turn off alarm.
2. Alarm will retest for normal operation. If condition has not been corrected, alarm will sound again.

Clean Condenser Light

Clean Condenser indicator light comes on after 3 months of elapsed time as a reminder to clean condenser coil.

Press Alarm Off pad to turn off Clean Condenser indicator light.

NOTE: Clean Condenser light will turn off after 72 hours.

Electronic Functional Description

Temperature Control Operation

For any temperature setting, outputs will be turned off/on based on cut-in/cut-out temperatures determined by resistance levels of freezer and refrigerator thermistors.

As the temperature decreases, resistance increases.
As the temperature increases, resistance decreases.

Refrigerator and Freezer Thermistor Part # C8983701 or C8983702

Temp °C (°F)	Resistance Ohms	Temp °C (°F)	Resistance Ohms
-29 (-20)	495600	2 (36)	87510
-26 (-15)	418200	3 (38)	82740
-23 (-9)	354000	4 (39)	78300
-21 (-6)	300600	6 (43)	74100
-18 (-4)	256200	7 (45)	70170
-15 (5)	218850	8 (46)	66450
-12 (10)	187170	9 (48)	62970
-9 (16)	161040	10 (50)	59670
-7 (19)	138690	13 (55)	52290
-4 (25)	119460	16 (61)	45900
-1 (30)	103680	18 (64)	40410
0 (32)	97920	21 (70)	36540
1 (34)	92550	25 (77)	30000

An open thermistor or thermistor circuit will result in failure of refrigerator to cool.

Shorted thermistor will cause refrigerator to run 100 percent of time except for defrost.

- Freezer temperature setting and thermistor value will determine if compressor/condenser fan and evaporator fan switches are open or closed. Compressor/condenser fan switch must be open for 6 minutes before switch can close again (compressor dwell time).
- Cut-out and cut-in temperature values must be reached and maintained for 15 seconds before output state will change (digital delay).
- Refrigerator and freezer control calibration can be adjusted in Program Mode B.

Factory Set Freezer and Refrigerator Settings Part #10866002

Frozen Food		Fresh Food		Level
Cut-Out °C ±1° (°F ±1.5°)	Cut-In °C ±1° (°F ±1.5°)	Cut-Out °C ±1° (°F ±1.5°)	Cut-In °C ±1° (°F ±1.5°)	
-23 (-10)	-16.6 (2)	-1.6 (29)	1.1 (34)	9
-22 (-8)	-15.5 (4)	-0.5 (31)	2.2 (36)	8
-21 (-6)	-14 (6)	0.5 (33)	3.3 (38)	7
-20.5 (-5)	-13.8 (7)	1.1 (34)	3.8 (39)	6
-20 (-4)	-13.3 (8)	1.6 (35)	4.4 (40)	5
-19 (-3)	-12.7 (9)	2.2 (36)	5 (41)	4
-18.8 (-2)	-12.2 (10)	2.7 (37)	5.5 (42)	3
-17.7 (0)	-11.1 (12)	3.8 (39)	6.6 (44)	2
-16.6 (2)	-10 (14)	5 (41)	7.7 (46)	1
-23 (-10)	-16.6 (2)	—	—	Fast Freeze
—	—	3.8 (39)	6.6 (44)	Max Cool

Damper Control

- Refrigerator temperature setting and thermistor value will determine if damper control heater switch is to be open or closed.
- Damper closes at 9°C (48°F).
- Damper opens at least 1/4" when minimum voltage is applied at 4°C (40°F) ambient.

Damper	Heater
Watts	Volts (DC)
2.00 Minimum	20.5 Minimum
2.74 Nominal	24.0 Nominal
3.60 Maximum	27.5 Maximum

Electronic Functional Description

Adaptive Defrost Operation

Defrost occurs after predetermined length of compressor run time. Compressor run time between defrosts changes, or adapts, depending upon recent history of defrost lengths (time it takes for defrost terminator to open after defrost heater has been turned on).

- Defrost terminator opens at 9°C (48°F) and closes at -9°C (15°F).
- Compressor run time between defrosts (CRTD) will be one of 3 values under normal operation: CRTD 1 (6 hours) or CRTD 2 (9 hours) or CRTD 3 (12 hours).

If defrost length is low (DT-LO defined as 21 minutes) indicating small frost load, CRTD for next defrost cycle is advanced to next level.

If defrost length is high (DI - HI defined as 24 minutes) indicating large frost load, CRTD for next defrost cycle is lowered to next level.

If defrost length is between 21 and 24 minutes, CRTD for next defrost cycle remains the same.

Initial value at power up CRTD 0 is 3 hours.

- Vacation Mode CRTD equals 72 hours. Vacation Mode CRTD is interrupted with door openings. Defrost interval will revert back to interval before Vacation Mode. Three things must occur to reach Vacation Mode CRTD:
 - 1) Defrost interval must be CRTD 3 (12 hours).
 - 2) Both refrigerator and freezer doors must have remained closed since last defrost cycle.
 - 3) Defrost thermostat must have opened in less than 21 minutes during last defrost cycle.
- Six minute dwell time occurs after defrost terminator opens before compressor and condenser fan motor will operate. Ten minute dwell time occurs after defrost terminator opens before evaporator fan motor will operate. Dwell time can be bypassed by disconnecting power to the unit for 30 seconds.
- Conventional defrost can be selected in Program Mode B.

Electronic Functional Description

Program Mode

Accessing Program Mode

Two programming modes are available. Mode A allows reading refrigerator and freezer thermistor temperatures. Mode B is used for all other programmable functions.

1. Open refrigerator door.
2. Press * pad.
3. Press *Vacation* pad.
4. Press the following sequence of pads within 6 seconds: *Max Cool*, *Fast Freeze*, *Max Cool*, *Fast Freeze*.
5. When access is granted, tone will sound three times and control will be in Program Mode A. Indicator light will illuminate.
6. Toggle to Program Mode B by pressing * pad. Indicator light is off.

EEPROM Update in Control Memory

EEPROM is permanent programmable memory of the control panel.

- Entry tone, door audio alarm and status are stored in EEPROM after control panel is deactivated.
- Clean coil status is stored in EEPROM after every defrost cycle as time until clean coil alarm is activated.
- Information stored in EEPROM memory is not affected by power loss.

Mode A Functions

Reading Temperature Display

Temperature display will show thermistor temperature in binary coded decimal format (BCD). Indicator lights 1 through 4 represent the tens digit with 1 being the most significant bit. Indicator lights 5 through 8 represent ones digit with 5 being the most significant bit. Positive and negative are shown by indicator light 9; light glows to show negative value

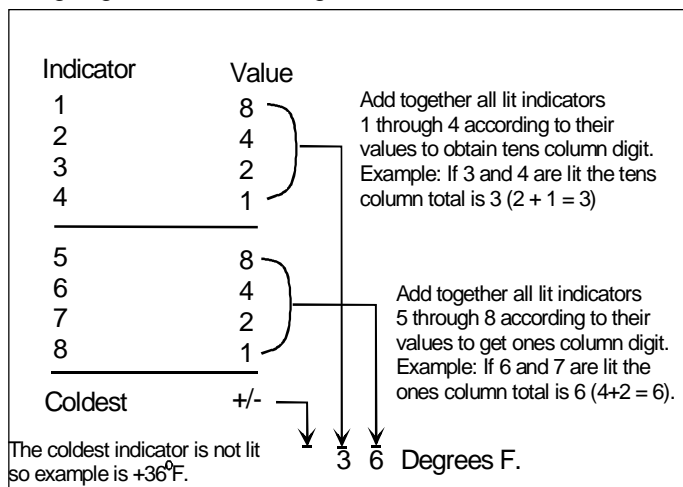

NOTE: Temperature reads degrees Fahrenheit only.
Use conversion formula °C=5/9(°F-32).

Freezer Thermistor Temperature

1. Choose freezer thermistor temperature display by pressing *Freezer Temp* pad.
2. Freezer thermistor temperature displays.

Refrigerator Thermistor Temperature

1. Choose refrigerator thermistor temperature display by pressing *Fresh Food Temp* pad.
2. Refrigerator thermistor temperature displays.

Mode B Functions

Automatic Keyboard Function

Activate and deactivate keyboard by toggling *Display Off* pad. If high temperature indicator glows, keyboard will disable after 10 minutes. If high temperature indicator is off, keyboard is always enabled. DO NOT LEAVE KEYBOARD IN ENABLED MODE AFTER PROGRAMMING IS COMPLETE.

Door Alarm Delay

1. Press *Alarm Off* pad. Door open indicator will glow. One temperature indicator should glow indicating present delay setting in minutes (indicator 1 means 1 minute, 2 means 2 minutes, etc.) Default delay is 3 minutes.
2. Press *Warmer* pad to decrease delay by 1 minute.
3. Press *Colder* pad to increase delay by 1 minute.

Max Cool Run Time Duration

1. Press *Max Cool* pad. *Max Cool* light will glow. One temperature indicator should glow indicating present *Max Cool* run time duration in 2 hour increments (indicator 1 means 2 hours, 2 means 4 hours, etc.) Default duration is 10 hours.
2. Press *Warmer* pad to decrease *Max Cool* duration by 2 hours.
3. Press *Colder* pad to increase *Max Cool* duration by 2 hours.

Fast Freeze Run Time Duration

1. Press *Fast Freeze* pad. *Fast Freeze* light will glow. One temperature indicator should glow indicating present *Fast Freeze* run time duration in 4 hour increments (indicator 1 means 4 hours, 2 means 8 hours, etc.) Default duration is 24 hours.
2. Press *Warmer* pad to decrease *Fast Freeze* duration by 4 hours.
3. Press *Colder* pad to increase *Fast Freeze* duration by 4 hours.

Electronic Functional Description

Program Mode

Temperature Offset Calibration

Offset amount adjusts temperatures for refrigerator cut-ins and cut-outs by the amount of offset. The chart below shows the indicator and the amount of offset from the factory default setting.

INDICATOR	OFFSET
1	+8
2	+6
3	+4
4	+2
5	0
6	-2
7	-4
8	-6
Coldest	-8

- Setting Refrigerator Temperature Offset
Press *Fresh Food Temp* pad. Refrigerator indicator and one indicator will glow. Press *Warmer* pad to move offset to the next warmer setting. Press *Colder* pad to move offset to the next colder setting. Factory default refrigerator offset is +2.
- Setting Freezer Temperature Offset
Press *Freezer Temp* pad. Freezer temperature indicator and one indicator will glow. Press *Warmer* pad to move offset to the next warmer setting. Press *Colder* pad to move offset to the next colder setting. Factory default freezer offset is 0.

Defrost Mode Selection

Toggle *Vacation* pad to select adaptive or conventional defrost mode. Vacation indicator glows when adaptive defrost has been selected. If Vacation indicator is off, conventional defrost is selected. Conventional defrost uses 6 hour CRTD value.

Forced Defrost

Defrost can be forced to start by pressing and holding the *Alarm Off* pad for 3 seconds. Program changes will be saved permanently in EEPROM and program mode will exit to Run Mode.

Forced Pulldown (Compressor Start)

Compressor start can be forced by pressing and holding *Fast Freeze* pad for 3 seconds. Program changes will be saved permanently in EEPROM. Compressor, evaporator fan, damper heater, and condenser fan will come on.

Exiting Program Mode

Press * pad for 3 seconds to exit Program Mode. Tone will sound three times. Changes made in Program Mode will be permanently saved in EEPROM.

NOTE: If no pad is pressed for 10 minutes, Program Mode will be automatically exited. No changes will be saved if Program Mode exits automatically.

Electronic Functional Description

Electronic Testing

Electronic Testing Mode

Forced Defrost Start

1. Press * pad to activate control panel.
2. Simultaneously press and hold *Max Cool* and *Display Off* pads for 3 seconds.

Forced Compressor Start

1. Press * pad to activate control panel.
2. Simultaneously press and hold *Fast Freeze* pad and *Display Off* pad for 3 seconds.

Open Thermistor Detect

Alarm sounds and freezer or refrigerator indicator light shows and temperature indicators 4 through 7 will turn on in sequence if either thermistor circuit opens. Refer to Temperature Control Operation Section and Electronic Testing Section.

1. Press *Alarm Off* pad to turn off alarm.
2. Alarm will retest for normal operation. If condition has not been corrected, alarm will sound again.

Evaporator Fan Suppression

The evaporator fan will turn off every time either refrigerator or freezer door is open.

To test if this function is operating:

1. Perform forced pull down procedure as noted above –evaporator fan should be on.
2. Open the refrigerator or freezer door–the fan should turn off.
3. Push the light switch off–the evaporator fan should start.

If fan does not toggle off and on when refrigerator light switch is turned off and on and it has been determined evaporator fan motor is operational, perform following tests to determine failure:

DANGER

To avoid electrical shock, personal injury or death, avoid contacting high voltage parts. Disconnect power to unit and discharge capacitor before handling.

1. Check for line voltage on terminal E7 on high voltage board. With refrigerator door open (refrigerator light ON) reading should be 230 VAC. With refrigerator door closed (refrigerator light OFF) reading should be approximately 0 VAC.

If voltage does not change with light switch and light switch is turning light off and on, red/white wire is broken between switch and high voltage board.

2. Check for voltage on terminal E7 on high voltage board. Output voltage should toggle with toggling of light switch. If output voltage does not toggle, high voltage board needs replacing.
3. If terminal 7 on high voltage board changes with opening and closing of door, orange wire in low voltage harness is broken (check for continuity between pin 7 on high voltage board and pin 10 on low voltage board) or low voltage board needs replacing.

DANGER

To avoid electrical shock, personal injury or death, avoid contacting high voltage parts. Disconnect power to unit and discharge capacitor before handling.

1. Check for line voltage on terminal E8 on high voltage board. With freezer door open, reading should be 230 VAC. With door closed, reading should be approximately 0 VAC. If voltage does not change with light switch and light switch is turning light off and on, violet/white wire is broken between switch and high voltage board.
2. Check for voltage on pin 7 on pin connector of high voltage board. Output voltage should toggle with toggling of light switch. If it does not toggle, high voltage board needs replacing.
3. If voltage on pin 7 on pin connector on high voltage board changes with opening and closing of door, orange wire in low voltage harness is broken (check for continuity between pin 7 on high voltage pin connector and pin 10 on low voltage board) or low voltage board needs replacing.

Electronic Functional Description

⚠ WARNING

To avoid electrical shock which can cause severe personal injury or death, disconnect power to refrigerator using power switch before servicing. Discharge capacitors through a resistor before handling. Wires removed during disassembly must be replaced on proper terminals to insure correct earthing and polarization. After servicing, reconnect power using power switch.

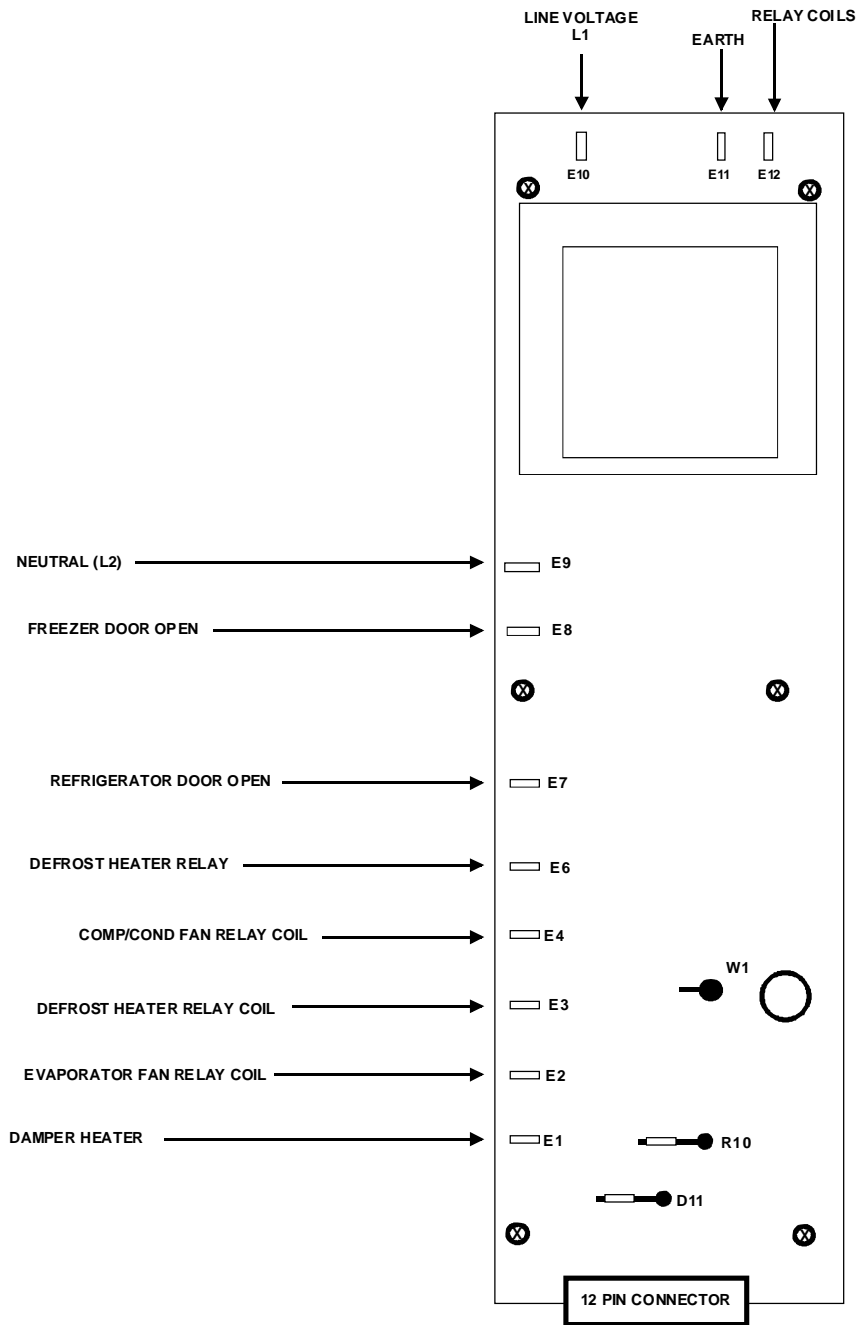
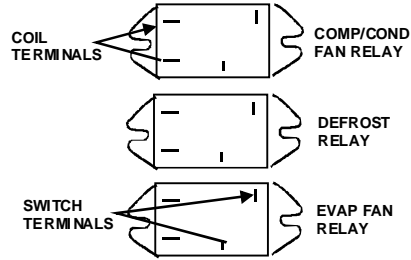

Electronic Functional Description



WARNING

To avoid electrical shock which can cause severe personal injury or death, disconnect power to refrigerator using power switch before servicing. Discharge capacitors through a resistor before handling. Wires removed during disassembly must be replaced on proper terminals to insure correct earthing and polarization. After servicing, reconnect power using power switch.

Resistance Checks Made at High Voltage Board

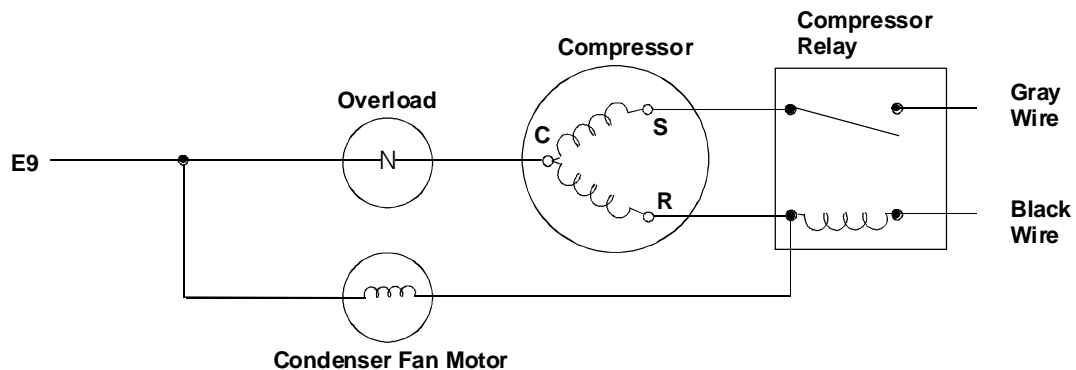
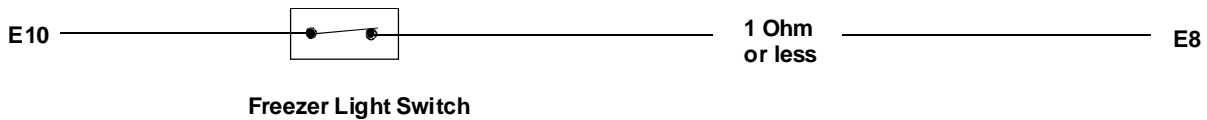
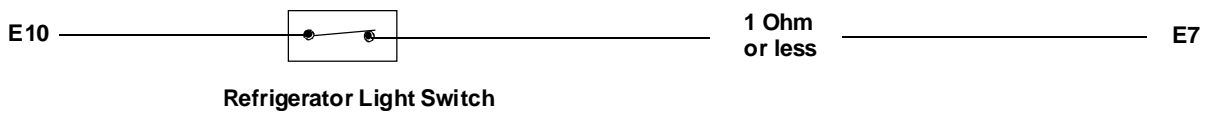
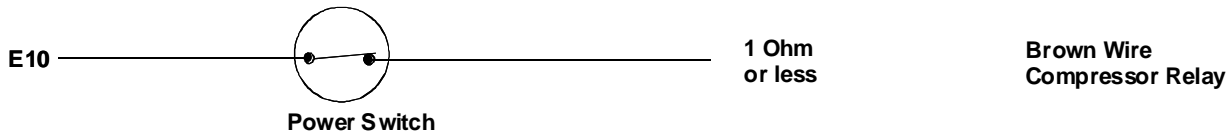
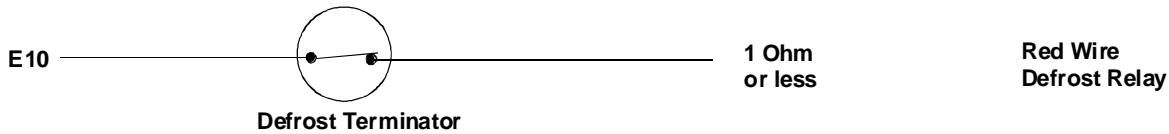

Electronic Functional Description



WARNING

To avoid electrical shock which can cause severe personal injury or death, disconnect power to refrigerator using power switch before servicing. Discharge capacitors through a resistor before handling. Wires removed during disassembly must be replaced on proper terminals to insure correct earthing and polarization. After servicing, reconnect power using power switch.

Refrigeration and Defrost Component Checks Made at High Voltage Board

Power Switch Is ON

Low voltage board input	W1 to D11		-25 VDC
High voltage board input	E10 (L)/E9 (N)		220 VAC
Compressor/condenser Fan motor	Blue/White Wire Comp/Relay to E9	Contacts Closed Contacts Open	220 VAC 0 VAC
Compressor/condenser Fan motor Relay coil	E4 to E12	Contacts Closed Contacts Open	220 VAC 0 VAC
Defrost heater	E6 to E9	Contacts Closed Contacts Open	220 VAC 0 VAC
Defrost heater Relay Coil	E3 to E12	Contacts Closed Contacts Open	-25 VDC 0 VDC
Defrost terminator (Klixon)	E6 to E9	Contacts Closed Contacts Open	220 VAC 0 VAC
Damper heater output From high voltage board	E1 to E11	Contacts Closed Contacts Open	-25 VDC 0 VDC
Damper heater input From low voltage board From high voltage board	R10 to E11	Contacts Closed Contacts Open	-11 VDC -25 VDC
Evaporator Fan Motor Relay Coil	E2 to E12	Contacts Closed Contacts Open	-25 VDC 0 VDC

Electronic Functional Description



WARNING

To avoid electrical shock which can cause severe personal injury or death, disconnect power to refrigerator using power switch before servicing. Discharge capacitors through a resistor before handling. Wires removed during disassembly must be replaced on proper terminals to insure correct earthing and polarization. After servicing, reconnect power using power switch.

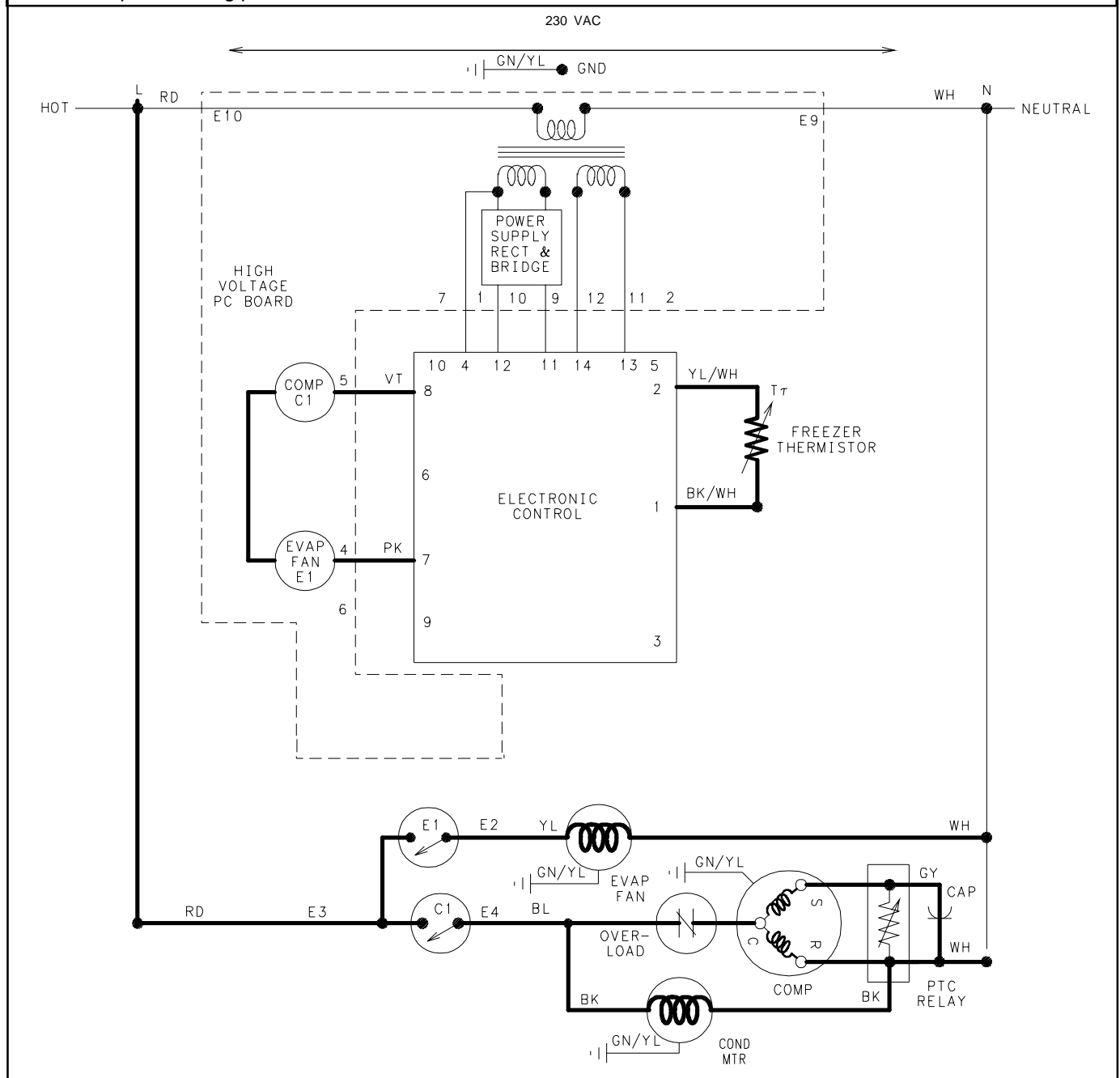

Freezer Compartment

As freezer thermistor warms the resistance decreases allowing low voltage signal to be sent to electronic control. Electronic control send two low voltage signals, one to the compressor relay coil (C1) and one to the evaporator fan relay coil (E1).

When both relay coils are energized and both relay

contacts are closed, high voltage circuits to evaporator fan motor and compressor/condenser fan motor are complete.

As thermistor cools during refrigeration cycle, resistance through thermistor increases blocking low voltage signal to electronic control interrupting circuit.

Electronic Functional Description

⚠ WARNING

To avoid electrical shock which can cause severe personal injury or death, disconnect power to refrigerator using power switch before servicing. Discharge capacitors through a resistor before handling. Wires removed during disassembly must be replaced on proper terminals to insure correct earthing and polarization. After servicing, reconnect power using power switch.

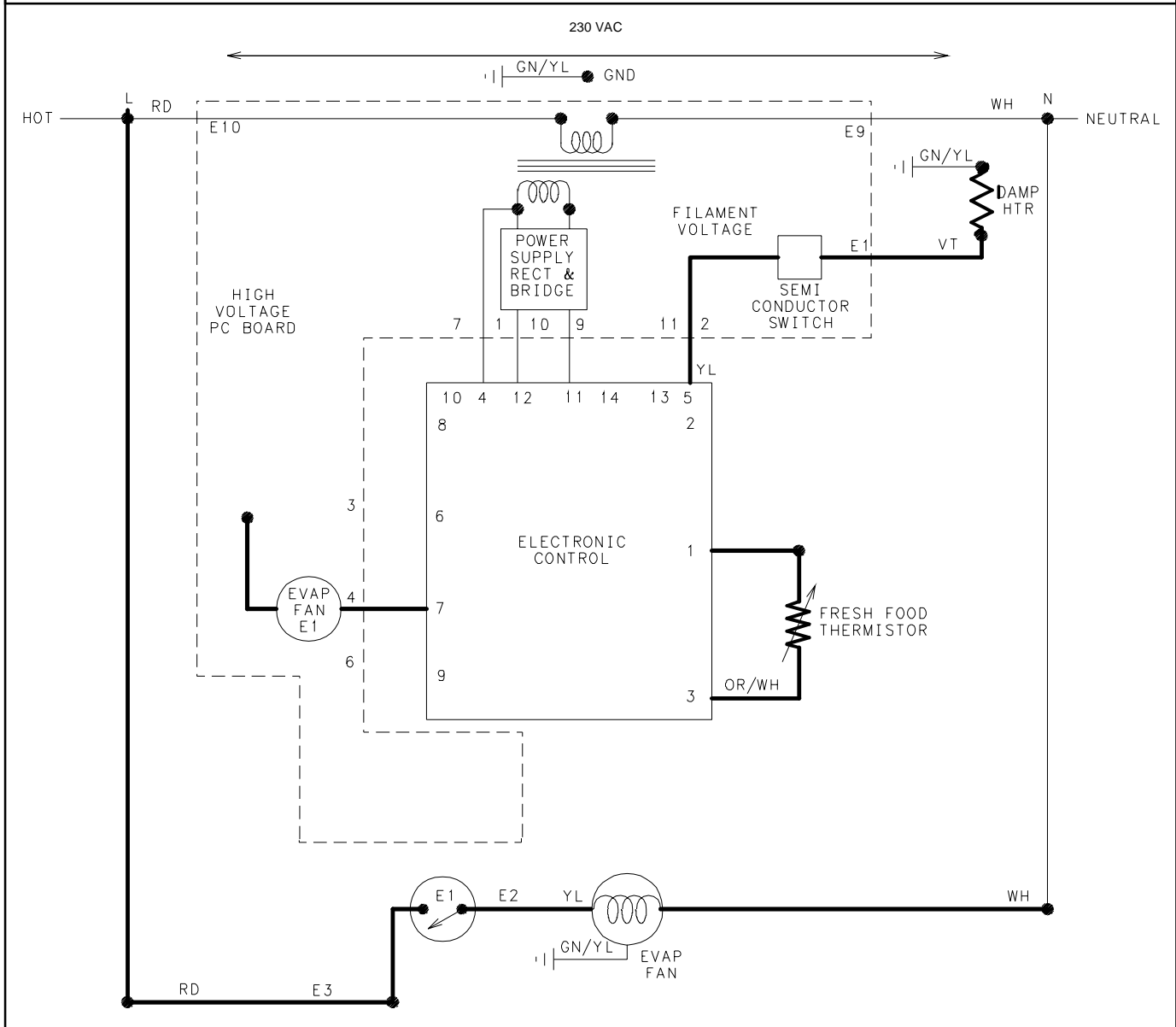

Refrigerator Compartment

As fresh food thermistor warms, resistance decreases allowing low voltage signal to be sent to the electronic control. Electronic control sends two low voltage signals, one to damper heater and one to evaporator fan relay coil (E1).

Damper heater warms damper control bellows, opening damper door at the same time relay coil closes high voltage contacts to evaporator fan motor.

With evaporator fan operating and damper door open, freezer air circulates into fresh food compartment. As fresh food thermistor cools, resistance increases blocking low voltage signal to electronic control interrupting circuit to evaporator fan motor relay coil and damper heater.

Electronic Functional Description



WARNING

To avoid electrical shock which can cause severe personal injury or death, disconnect power to refrigerator using power switch before servicing. Discharge capacitors through a resistor before handling. Wires removed during disassembly must be replaced on proper terminals to insure correct earthing and polarization. After servicing, reconnect power using power switch.

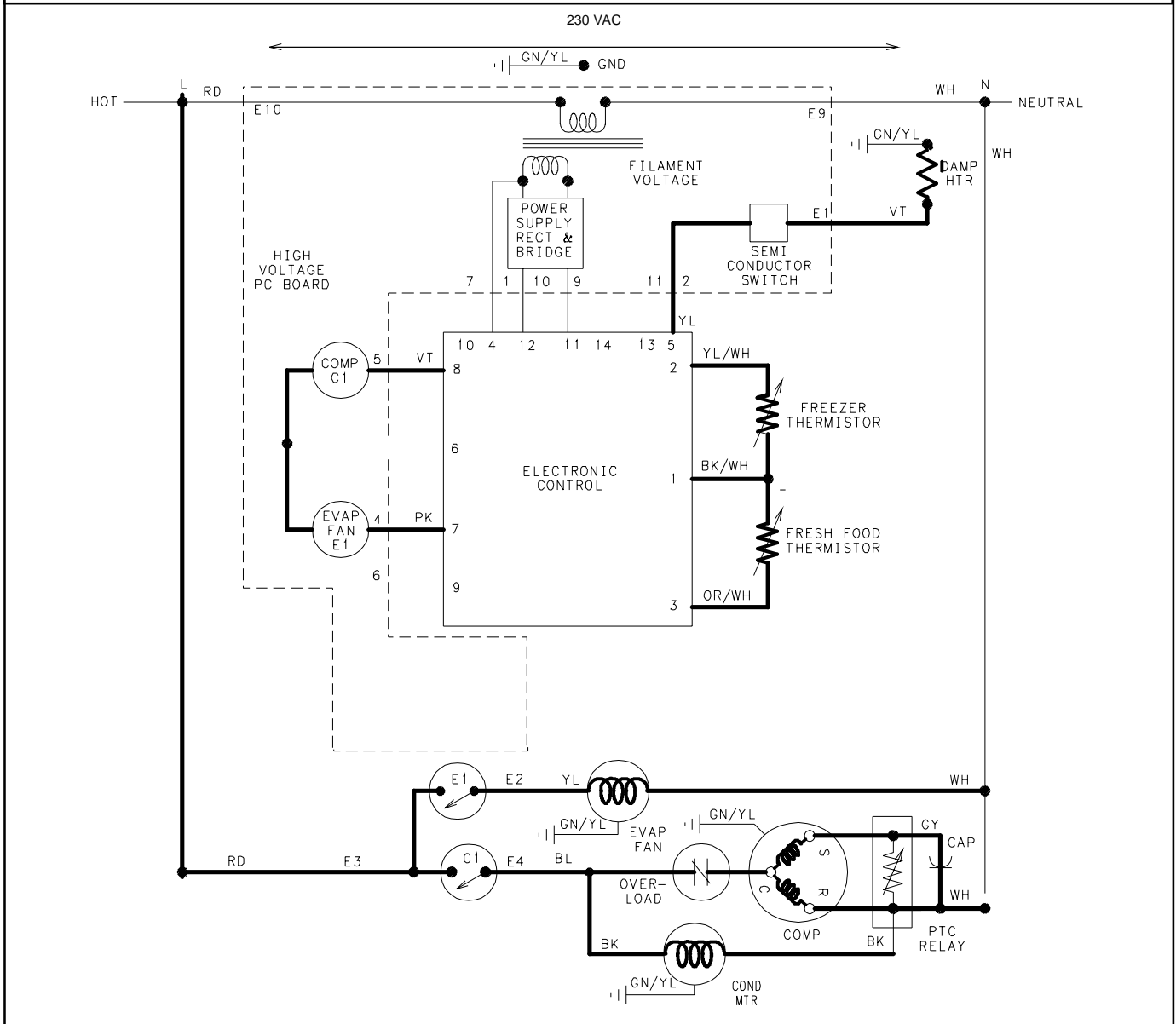

Refrigerator and Freezer Compartment

If both freezer and fresh food thermistors are warm, the electronic control signals for compressor/condenser fan motor operation and for damper door to open.

After freezer thermistor cools sufficient to block signal to electronic control the compressor/condenser fan motor will shut off. However, evaporator fan motor and damper heater will continue to run until fresh food thermistor cools and signal is blocked to electronic control.

If fresh food thermistor cools before freezer thermistor, electronic control will interrupt circuit to damper heater closing damper door while evaporator fan motor will continue to run under control of freezer thermistor.

Electronic Functional Description

⚠ WARNING

To avoid electrical shock which can cause severe personal injury or death, disconnect power to refrigerator using power switch before servicing. Discharge capacitors through a resistor before handling. Wires removed during disassembly must be replaced on proper terminals to insure correct earthing and polarization. After servicing, reconnect power using power switch.

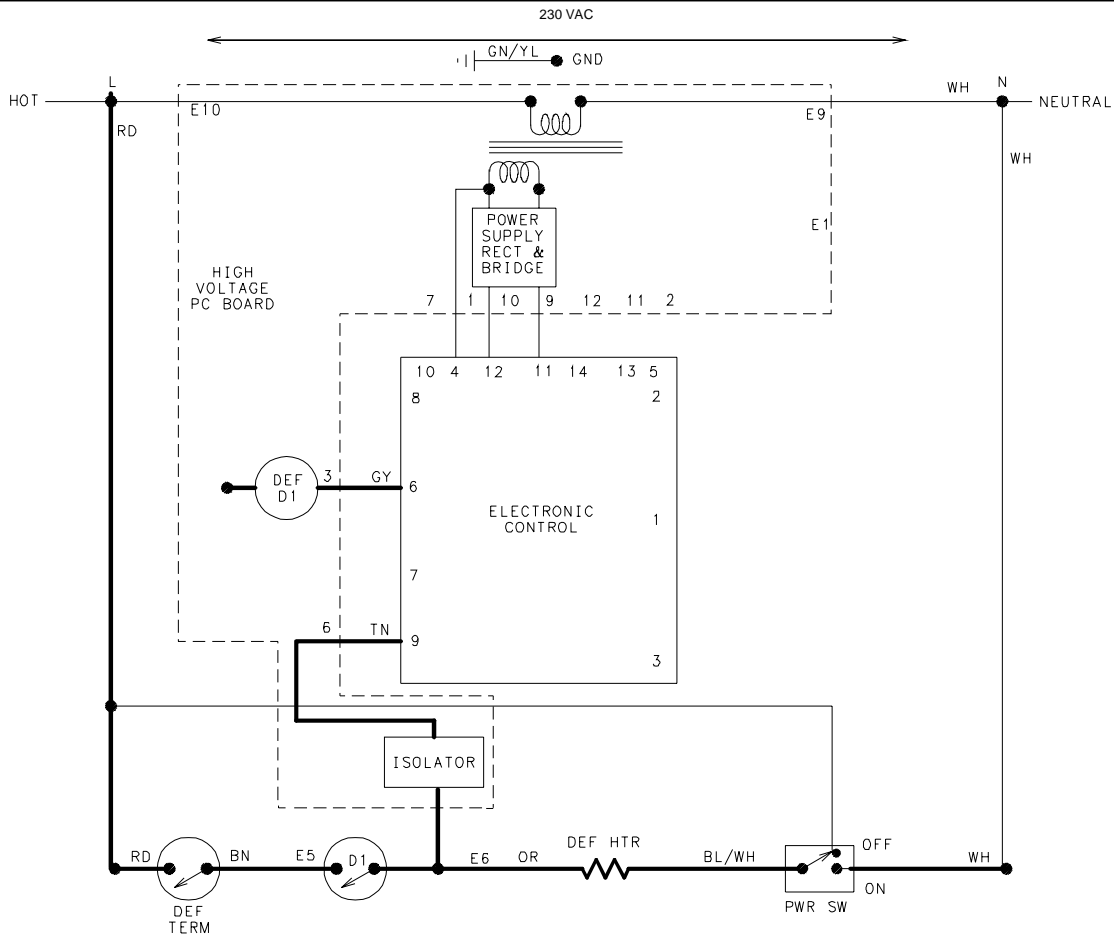

IMPORTANT: When the power switch is *OFF*, the isolator sees line voltage which keeps the electronic controller from signaling the evaporator fan motor or the compressor relay coils and also keeps the damper heater off.

Adaptive Defrost

After designated compressor run time, refrigeration cycle is interrupted and electronic control sends a low voltage signal to defrost relay coil (def D1).



Powering the relay coil closes relay contact (D1) completing high voltage circuit to defrost heater through closed defrost terminator (closes at -9°C).

Isolator, which is part of high voltage PC board, recognizes presence of line voltage to defrost heater and sends low voltage signal to electronic control. Electronic control keeps count of number of minutes defrost terminator remains closed (opens at 9°C).

Length of time defrost terminator is closed determines if the next defrost cycle advances by 3 hours of compressor run, stays at the same interval, or delays by 3 hours of compressor run.

If defrost terminator does not open before 29 minutes, defrost cycle is automatically terminated by electronic control and refrigeration cycles will resume after 6 minute dwell time.

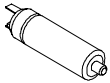
Component Testing

Component	Description	Test Procedures
<p>Capacitor</p> 	<p>Run capacitor connects to relay terminal 3 and L side of line.</p> <p>Auger motor capacitor is in series with auger motor. Auger motor capacitor does not have identified terminals and can be wired without regard to polarity.</p>	<div style="border: 1px solid black; padding: 5px; text-align: center;">  <b style="font-size: 1.2em;">WARNING </div> <p>To avoid electrical shock which can cause severe personal injury or death, discharge capacitor through a resistor before handling.</p> <ol style="list-style-type: none"> 1. Disconnect power to refrigerator. 2. Remove capacitor cover and disconnect capacitor wires. 3. Discharge capacitor by shorting across terminals with a resistor for 1 minute. 4. Check resistance across capacitor terminals with ohmmeter set on "X1K" scale. <ul style="list-style-type: none"> • Good—needle swings to 0 ohms and slowly moves back to infinity. • Open—needle does not move. Replace capacitor. • Shorted—needle moves to zero and stays. Replace capacitor. • High resistance leak—needle jumps toward 0 and then moves back to constant high resistance (not infinity).
<p>Capillary tube</p>	<p>Capillary is sized in diameter and length to feed proper amount of refrigerant to evaporator.</p> <p>Capillary is soldered to suction line to transfer heat from capillary and add additional superheat to gas refrigerant in compressor suction line.</p> <p>Capillary discharges into evaporator.</p>	<p>Restricted or clogged capillary tube must be replaced with tube of same inner diameter and length.</p> <p>Follow all procedures for evacuation and charging of sealed system and for safe handling of refrigerant.</p>



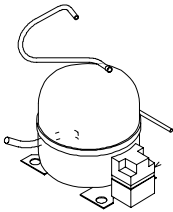
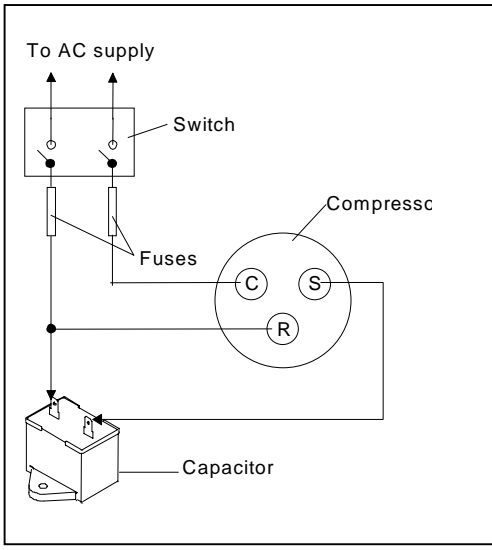

Component Testing

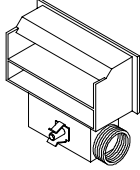
Component	Description	Test Procedures
<p data-bbox="99 170 224 197">Compressor</p> 	<p data-bbox="282 170 683 409">When compressor electrical circuit is energized, the start winding current causes relay to heat. After an amount of starting time, the start winding circuit turns off. The relay will switch off the start winding circuit even though compressor has not started (for example, when attempting to restart after momentary power interruption).</p> <p data-bbox="282 420 683 535">With "open" relay, compressor will not start because there is little or no current to start windings. Overload protection will open due to high locked rotor run winding current.</p> <p data-bbox="282 556 683 682">With "shorted" relay or capacitor, compressor will start and overload protector will quickly open due to high current of combined run and start windings.</p> <p data-bbox="282 703 683 787">With open or weak capacitor, compressor will start and run as normal but will consume more energy.</p>	<p data-bbox="683 170 852 197">Resistance test</p> <ol data-bbox="683 197 1456 388" style="list-style-type: none"> 1. Disconnect power to unit. 2. Discharge capacitor by shorting across terminals with a resistor for 1 minute. 3. Remove leads from compressor terminals. 4. Set ohmmeter to lowest scale. 5. Check for resistance between <ul style="list-style-type: none"> Terminals "S" and "C" Terminals "R" and "C" <p data-bbox="683 388 1456 451">If either compressor winding reads open (infinite or very high resistance) or dead short (0 ohms), replace compressor.</p> <p data-bbox="683 462 820 489">Earthing test</p> <ol data-bbox="683 489 1456 630" style="list-style-type: none"> 1. Disconnect power to refrigerator. 2. Discharge capacitor by shorting terminals through a resistor. 3. Remove compressor leads and use an ohmmeter set on highest scale. 4. Touch one lead to compressor body (clean point of contact) and the other probe to each compressor terminal. <p data-bbox="683 630 1456 651">If a reading is obtained, compressor is earthed and must be replaced.</p> <p data-bbox="683 661 836 688">Operation test</p> <p data-bbox="683 688 1456 724">If voltage, capacitor, overload, and motor winding tests do not show cause for failure, perform the following test:</p> <ol data-bbox="683 724 1456 997" style="list-style-type: none"> 1. Disconnect power to refrigerator using power switch. 2. Discharge capacitor by shorting capacitor terminals through a resistor. 3. Remove leads from compressor terminals. 4. Wire a test cord to power switch. 5. Place time delayed fuse with UL rating equal to amp rating of motor in test cord socket. (See Technical Data Sheet) 6. Remove overload and relay. 7. Connect start, common and run leads of test cord on appropriate terminals of compressor. 8. Attach capacitor leads of test cord together. If capacitor is used, attach capacitor lead to a known good capacitor of same capacity. <div data-bbox="738 997 1226 1543" style="border: 1px solid black; padding: 10px; margin: 10px 0;">  </div> <ol data-bbox="683 1596 1456 1890" style="list-style-type: none"> 9. Plug test cord into volt-watt meter to determine start and run wattage as well as check for low voltage which can also be a source of trouble. 10. With power to volt-meter, press start cord switch and release. <ul style="list-style-type: none"> • If compressor motor starts and draws normal wattage, compressor is okay and trouble is in capacitor, relay/overload, freezer temperature control, or elsewhere in system. • If compressor does not start when direct wired, recover system at high side. After system is recovered, repeat compressor direct wire test. If compressor runs after recovery but would not run when direct wired before recover, a restriction in sealed system is indicated. • If compressor does not run when wired direct after recover, replace faulty compressor.

Component Testing

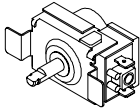
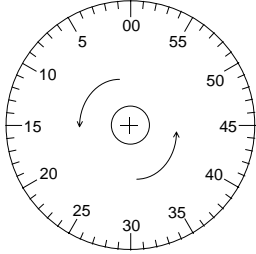
Component	Description	Test Procedures
<p>Condenser</p>	<p>Condenser is a tube and wire construction and is located in compressor compartment.</p> <p>Condenser is on the high pressure discharge side of compressor. Condenser function is to transfer heat absorbed by refrigerant to ambient.</p> <p>Higher pressure gas is routed to condenser where, as gas temperature is reduced, gas condenses into a high pressure liquid state. Heat transfer takes place because discharged gas is at a higher temperature than air that is passing over condenser. It is very important that adequate air flow over condenser is maintained.</p> <p>Condenser is air cooled by condenser fan motor. If efficiency of heat transfer from condenser to surrounding air is impaired, condensing temperature becomes higher. High liquid temperature means the liquid will not remove as much heat during boiling in evaporator as under normal conditions. This would be indicated by higher than normal head pressures, long run time, and high wattage. Remove any lint accumulation, etc. that would restrict normal air movement through condenser.</p> <p>From condenser the refrigerant flows into a post condenser loop which helps control exterior condensation on flange, center mullion, around freezer door and then through the drier to the evaporator and into the compressor through the suction line.</p>	<p>Leaks in condenser can usually be detected by using an electronic leak detector or soap solution. Look for signs of compressor oil when checking for leaks. A certain amount of compressor oil is circulated with refrigerant.</p> <p>Leaks in post condenser loop are rare because loop is a one-piece copper tube.</p> <p>For minute leaks</p> <ol style="list-style-type: none"> 1. Separate condenser from rest of refrigeration system and pressurize condenser up to a maximum of 16 bars (235 PSI) with a refrigerant and dry nitrogen combination. 2. Recheck for leaks. <div data-bbox="769 485 1511 730" style="border: 1px solid black; padding: 10px; margin: 10px 0;"> <p style="text-align: center;"> WARNING</p> <p>To avoid severe personal injury or death observe the following:</p> <ul style="list-style-type: none"> • Protect against a sudden eruption if high pressures are required for leak checking. • Do not use high pressure compressed gases in refrigeration systems without a reliable pressure regulator and pressure relief valve in the lines. </div>
<p>Damper Control</p> 	<p>Damper control balances the air delivery between refrigerator and freezer compartments. Integral capillary activates damper control and door closes restricting flow of air from freezer compartment to refrigerator compartment.</p> <p>There are no electrical connections to damper control on non-electronic units. See Electronic Functional Description for explanation of damper control on electronic units.</p>	<p>Subject capillary to appropriate temperature (see tech sheet for model being serviced).</p> <p>Damper door should close to within 6 mm of completely shut.</p> <p>If altitude adjustment is required, turn altitude adjustment screw 1/8 turn clockwise for each 305 meters increase in altitude.</p>



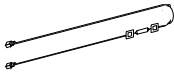
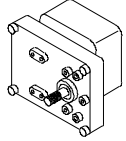
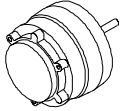
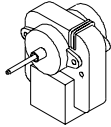
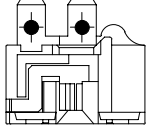

Component Testing

Component	Description	Test Procedures																						
<p>Control, freezer temperature (Non-electronic units)</p> 	<p>Freezer temperature control is a capillary tube operating a single pole, single throw switch.</p> <p>Altitude Adjustment When altitude adjustment is required on a G.E. control, turn altitude adjustment screw 1/7 turn clockwise for each 305 meters increase in altitude up to 3,050 meters.</p> <p>In most cases the need for altitude adjustments can be avoided by simply turning temperature control knob to colder setting.</p>	<p>Check for proper calibration with thermocouple capillary in air supply well by recording cut-in and cut-out temperatures in middle setting. See tech sheet for model being serviced for expected temperatures.</p> <p>Check control contacts are opening by disconnecting electrical leads to control turning control knob to coldest setting and checking for continuity across terminals.</p> <p>Altitude correction must be done on both "cut-in" and "cut-out" screws.</p> <table border="1" data-bbox="683 401 1047 724"> <thead> <tr> <th colspan="2">Altitude Counter in Meters</th> </tr> <tr> <th>Meters</th> <th>Clockwise Turns</th> </tr> </thead> <tbody> <tr><td>610</td><td>7/60</td></tr> <tr><td>915</td><td>13/60</td></tr> <tr><td>1220</td><td>19/60</td></tr> <tr><td>1525</td><td>25/60</td></tr> <tr><td>1830</td><td>31/60</td></tr> <tr><td>2135</td><td>37/60</td></tr> <tr><td>2440</td><td>43/60</td></tr> <tr><td>2745</td><td>49/60</td></tr> <tr><td>3050</td><td>55/60</td></tr> </tbody> </table> 	Altitude Counter in Meters		Meters	Clockwise Turns	610	7/60	915	13/60	1220	19/60	1525	25/60	1830	31/60	2135	37/60	2440	43/60	2745	49/60	3050	55/60
Altitude Counter in Meters																								
Meters	Clockwise Turns																							
610	7/60																							
915	13/60																							
1220	19/60																							
1525	25/60																							
1830	31/60																							
2135	37/60																							
2440	43/60																							
2745	49/60																							
3050	55/60																							
<p>Drier</p> 	<p>Drier is placed at post condenser loop outlet and passes liquefied refrigerant to capillary.</p>	<p>Drier must be changed every time the system is opened for testing or compressor replacement.</p> <p>NOTE: Drier used in R12 sealed system is not interchangeable with drier used in R134a sealed system. Always replace the drier with Amana part number B2150504.</p> <p>Before opening refrigeration system, recover HFC134a refrigerant for safe disposal.</p> <p>Cut drier out of system using the following procedure. Do not unbraid drier. Applying heat to remove drier will drive moisture into the system.</p> <ol style="list-style-type: none"> Score capillary tube close to drier and break. Reform inlet tube to drier allowing enough space for large tube cutter. Cut circumference of drier 3 cm below condenser inlet tube joint to drier. Remove drier. Apply heat trap paste on post condenser tubes to protect grommets from high heat. Unbraid remaining part of drier. Remove drier from system. Discard drier in safe place. Do not leave drier with customer. If refrigerant is under warranty, old drier must accompany warranty claim. <div data-bbox="711 1178 1414 1339" style="border: 1px solid black; padding: 5px;"> <p style="text-align: center;"> CAUTION</p> <p>To avoid death or severe personal injury, cut drier at correct location. Cutting drier at incorrect location will allow desiccant beads to scatter. If spilled, completely clean area of beads.</p> </div>																						
<p>Evaporator</p>	<p>Inner volume of evaporator allows liquefied refrigerant discharged from capillary to expand into refrigerant gas.</p> <p>Expansion cools evaporate tube and fin temperature to approximately -29°C (-20°F) transferring heat from freezer section to refrigerant.</p> <p>Passing through suction line to compressor, the refrigerant picks up superheat (a relationship between pressure and temperature that assures complete vaporization of liquid refrigerant) as result of capillary on suction line.</p> <p>Refrigerant gas is pulled through suction line by compressor to complete the refrigerant cycle.</p>	<p>Test for leaks in evaporator with electronic leak detector or with soap solution. Compressor oil is circulated with refrigerant; check for oil when checking for leaks.</p> <div data-bbox="711 1444 1414 1675" style="border: 1px solid black; padding: 5px;"> <p style="text-align: center;"> WARNING</p> <p>To avoid severe personal injury or death observe the following:</p> <ul style="list-style-type: none"> Protect against a sudden eruption if high pressures are required for leak checking. Do not use high pressure compressed gases in refrigeration systems without a reliable pressure regulator and pressure relief valve in the lines. </div> <p>For minute leaks</p> <ol style="list-style-type: none"> Separate evaporator from rest of refrigeration system and pressurize condenser up to a maximum of 10 bars (140 PSI) with a refrigerant and dry nitrogen combination. Recheck for leaks. 																						

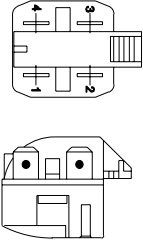
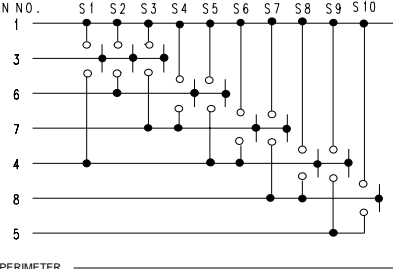
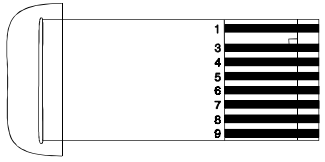

Component Testing

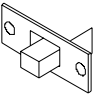
<p>Fusible link</p> 	<p>Fusible link is part of evaporator heater wiring harness and is in a series circuit with defrost terminator, defrost heater, and evaporator fan motor.</p> <p>If the defrost terminator fails to open and temperature increases to fusible link, fuse will open breaking circuit so defrost heater will be shut down.</p>	<p>If fusible link interrupts opens, evaporator heater wiring harness must be replaced.</p> <p>Be sure harness is wire tied against evaporator heater over white mark on evaporator heater.</p>
<p>Heater, door</p>	<p>Applied to back of ice and water cavity to help prevent condensation from forming on face of cavity.</p>	<p>Some models have spare heater foamed in place at factory. See tech sheet for model being serviced.</p> <p>Check resistance across heater (for resistance values see tech sheet for model being serviced).</p>
<p>Heater, evaporator (defrost)</p>	<p>Activated when defrost thermostat or adaptive defrost control completes the circuit through the heater.</p>	<p>Check resistance across heater.</p> <p>To check defrost system</p> <ol style="list-style-type: none"> 1. Thermocouple defrost thermostat and plugging refrigerator into wattmeter. 2. Force into defrost mode (see section on electronic testing). Wattmeter should read specified watts (according to tech sheet). 3. When defrost thermostat reaches specified temperature (see tech sheet) $\pm 5^{\circ}\text{F}$; thermostat should interrupt power to heater.
<p>Ice Maker</p>	<p>See "Ice Maker" section for service information.</p>	
<p>Motor, auger</p> 	<p>Located behind ice bucket. Drives helix auger and cube crusher.</p> <p>PSC (Permanent Split Capacitor) motor requiring a run capacitor.</p> <p>Controlled by ice actuator switch in series with freezer door auger interlock switch and cube/crushed ice switch.</p> <p>Internal overload trips out after approximately 90 second of continuous run and resets in approximately 3 minutes.</p>	<p>Disconnect power and ohm winding and check for earthing.</p> <p>Crushed/Cube Dispensing Models: At room ambient temperature check resistance between wire leads (see tech sheet for colors on unit being serviced).</p> <p>Cube Dispensing Models: At room ambient temperature check resistance cross motor windings. For resistance values see tech sheet for model being serviced.</p>
<p>Motor, condenser</p> 	<p>Condenser fan moves cooling air across condenser coil and compressor body.</p> <p>Condenser fan motor is in parallel circuit with compressor.</p>	<p>Check resistance across winding (for resistance value see tech sheet for model being serviced).</p>
<p>Motor, evaporator fan</p> 	<p>Evaporator motor moves air across evaporator coil and throughout refrigerator.</p> <p>Evaporator fan is in a series circuit with temperature control, defrost terminator, and defrost heater.</p>	<ol style="list-style-type: none"> 1. Disconnect power to unit. 2. Disconnect fan motor leads. 3. Check resistance from earth connection solder. Trace to motor frame must not exceed .05 ohms. 4. Check for voltage at connector to motor with terminator and temperature control closed.
<p>Overload/Relay</p> 	<p>Overload is a temperature and current sensing device.</p> <p>Overload opens when high current or high compressor temperature is sensed.</p> <p>After overload opens, reset can require up to two hours depending on ambient temperature and residual heat load in compressor.</p> <p>Relay (See PTC Relay)</p>	<ol style="list-style-type: none"> 1. Disconnect power to the refrigerator. 2. Remove relay cover and pull relay off compressor. Pull overload protector off compressor common terminal. 3. With ohmmeter, check the resistance between male terminal and female pin receptacle terminal which pushes onto compressor common terminal. At ambient room temperature overload protector should have less than 1 ohm resistance. An open overload protector will have infinite resistance.

Component Testing

<p>Relay, PTC</p> 	<p>When voltage is connected and relay is cool, current passes through relay to start winding. After a short time, current heats the resistor in relay and resistance will rise blocking current flow through relay. Start winding remains in the circuit through run capacitor.</p> <p>Solid state relay plugs directly on compressor start and run terminals. Relay terminals 2 and 3 are connected within relay. Run capacitor is connected to relay terminal 3. L2 side of 230 VAC power is connected to relay terminal 2.</p>	<p>With power off check resistance across terminals 2 and 3: Normal = 3 to 12 ohms Shorted = 0 ohms Open = infinite ohms</p>																																												
<p>Switch, keyboard</p>	<p>Semiconductor switch for control panel keyboard.</p>	<table border="1" data-bbox="695 527 1052 989"> <thead> <tr> <th>Switch Functions</th> <th>Keypad Symbol</th> <th></th> <th>Continuity Test</th> </tr> </thead> <tbody> <tr> <td>Enable Key</td> <td>✱</td> <td>S1</td> <td>1 and 3</td> </tr> <tr> <td>Freezer Temperature</td> <td>❄️</td> <td>S2</td> <td>3 and 6</td> </tr> <tr> <td>Refrigerator Temperature</td> <td>❄️</td> <td>S3</td> <td>3 and 7</td> </tr> <tr> <td>Warmer</td> <td>☀️</td> <td>S4</td> <td>6 and 7</td> </tr> <tr> <td>Colder</td> <td>❄️</td> <td>S5</td> <td>4 and 6</td> </tr> <tr> <td>Vacation</td> <td>🏠</td> <td>S6</td> <td>4 and 7</td> </tr> <tr> <td>Max Cool</td> <td>❄️</td> <td>S7</td> <td>7 and 8</td> </tr> <tr> <td>Fast Freeze</td> <td>❄️</td> <td>S8</td> <td>4 and 8</td> </tr> <tr> <td>Alarm Off</td> <td>🚫</td> <td>S9</td> <td>4 and 5</td> </tr> <tr> <td>Display Off</td> <td>🚫</td> <td>S10</td> <td>5 and 8</td> </tr> </tbody> </table> <div data-bbox="1052 506 1464 989"> <p>PIN NO. S1 S2 S3 S4 S5 S6 S7 S8 S9 S10</p>  <p>PERIMETER STATIC GUARD</p>  </div>	Switch Functions	Keypad Symbol		Continuity Test	Enable Key	✱	S1	1 and 3	Freezer Temperature	❄️	S2	3 and 6	Refrigerator Temperature	❄️	S3	3 and 7	Warmer	☀️	S4	6 and 7	Colder	❄️	S5	4 and 6	Vacation	🏠	S6	4 and 7	Max Cool	❄️	S7	7 and 8	Fast Freeze	❄️	S8	4 and 8	Alarm Off	🚫	S9	4 and 5	Display Off	🚫	S10	5 and 8
Switch Functions	Keypad Symbol		Continuity Test																																											
Enable Key	✱	S1	1 and 3																																											
Freezer Temperature	❄️	S2	3 and 6																																											
Refrigerator Temperature	❄️	S3	3 and 7																																											
Warmer	☀️	S4	6 and 7																																											
Colder	❄️	S5	4 and 6																																											
Vacation	🏠	S6	4 and 7																																											
Max Cool	❄️	S7	7 and 8																																											
Fast Freeze	❄️	S8	4 and 8																																											
Alarm Off	🚫	S9	4 and 5																																											
Display Off	🚫	S10	5 and 8																																											
<p>Switch, SPDT icemaker interlock</p> 	<p>Interrupts connection to auger motor and icemaker when freezer door is open. Turns freezer light on when door is open.</p> <p>In series with auger motor and cube/crushed switch and freezer light.</p>	<p>Check resistance across terminals. Continuity across terminals 1 and 2 – light Continuity across terminals 1 and 3 – auger motor</p>																																												
<p>Switch, crushed/cubed</p> 	<p>Selects between cubed or crushed ice feature.</p>	<p>Check resistance across terminals.</p> <p>Switch left Middle terminal to left terminal 0 ohms Middle terminal to right terminal infinite ohms</p> <p>Switch right Middle terminal to right terminal 0 ohms Middle terminal to left terminal infinite ohms</p>																																												
<p>Switch, refrigerator light, freezer light, refrigerator fan</p> 	<p>Completes circuit to allow indicated function. See tech sheet and wiring diagram for individual switch.</p>	<p>Check resistance across terminals.</p> <p>Switch arm down "NC" terminals Closed "NO" terminals Open</p> <p>Switch arm up "NC" terminals Open "NO" terminals Closed</p>																																												
<p>Switch, power</p> 	<p>SPDT</p> <p>Electronic models only. Disconnects power to high voltage board when switch is off (open.)</p> <p>Unit shipped with switch on.</p>	<p>Check resistance across terminals</p> <p>Switch OFF 0 ohms Switch ON infinite ohms</p>																																												

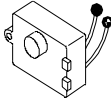
Component Testing

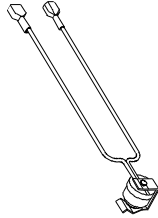
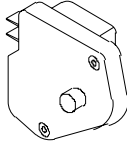
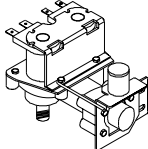
<p>Switch, photosensitive</p> 	<p>In series with cavity light switch and cavity light. Senses low light condition to complete circuit to cavity light.</p> <p>Switch must not generate line conducted noise or radiate interference more than three feet on the AM, FM, VHF, or USH Frequency bands.</p>	<ol style="list-style-type: none"> 1. To check light sensor with cavity light switch on, cover light sensor eye. Cavity lamp should light at approximately 50% of full illumination. 2. If lamp fails to illuminate, activate water or ice dispenser switch. Lamp should illuminate at full illumination and water or ice should be dispensed. 3. If light illuminates, disconnect power and replace light sensor. 4. If lamp does not illuminate, disconnect power and check cavity lamp and socket.
<p>Thermistor</p> 	<p>Senses temperatures within refrigerator and freezer compartments.</p>	<p>Check resistance across terminals. See tech sheet for bell curve resistance chart at given temperatures.</p>
<p>Thermostat</p> 	<p>Thermostat is in a series circuit with defrost terminators, defrost heater, and evaporator fan motor. Circuit is complete if evaporator fan motor operates when cold.</p> <p>Controls the circuit from freezer thermostat through defrost terminator to defrost heater. Opens and breaks circuit when thermostat senses preset high temperature.</p> <p>After defrost thermostat opens, thermostat remains open until end of defrost cycle and refrigerator starts cooling again and defrost thermostat senses a preset low temperature and closes.</p>	<p>Test continuity across terminals.</p> <p>With power off and evaporator coil below freezing, thermostat should check continuous when checked with ohmmeter. See "Heater, evaporator (defrost)" section for additional tests.</p>
<p>Timer, defrost</p> 	<p>Timer motor operates only when freezer control is closed. After specified amount of actual compressor run time, inner cam in timer throws the contacts from terminal 4, the compressor circuit to terminal 2, and defrost thermostat/defrost heater circuit.</p> <p>After 33 minutes of defrost cycle time, timer cam resets the circuitry through terminal 4 to compressor.</p>	<ol style="list-style-type: none"> 1. To check timer motor winding, check for continuity between terminals 1 and 3 of timer. 2. Depending on the rotation of the cam, terminal 1 of timer is common to both terminal 2, the defrost modes, or terminal 1, the compressor mode. There should never be continuity between terminals 2 and 4. 3. With continuity between terminals 1 and 4, rotate timer knob clockwise until audible click is heard. When the click is heard, the reading between terminals 1 and 4 should be infinite and there should be continuity between terminals 1 and 2. 4. Continuing to rotate time knob until a second click is heard should restore circuit between terminals 1 and 4.
<p>Valve, water</p> 	<p>Controls water flow to the ice maker and cavity.</p>	<p>Check resistance across coil windings.</p>

Product Design



WARNING

To avoid risk of electrical shock, personal injury, or death, disconnect electrical power source to unit and discharge capacitor through a 10,000 ohm resistor before attempting to service, unless test procedures require power to be connected. Ensure all earth wires are connected before certifying unit as repaired and/or operational.

Refrigeration System

Compressor forces high temperature vapor into fan-cooled tube and wire condenser where vapor is cooled and condensed into high pressure liquid by circulation of air across condenser coil. (See Refrigerant Flow Diagram.)

High pressure liquid passes through molecular sieve drier and into capillary tube. Small inside diameter of capillary offers resistance decreasing pressure and temperature of liquid discharged into evaporator. Capillary diameter and length is carefully designed for each system.

Capillary enters evaporator at top back. Combined liquid and saturated gas flows through back to bottom of coil and into suction line. Aluminium tube evaporator coil is located in freezer compartment where circulating evaporator fan moves air through coil and into fresh food compartment.

Large surface of evaporator allows heat to be absorbed from both fresh food and freezer compartments by airflow over evaporator coil causing some of the liquid to evaporate. Temperature of evaporator tubing near end of running cycle may vary from -25° to -32°C .

Saturated gas is drawn off through suction line where superheated gas enters compressor. To raise temperature of gas, suction line is placed in heat exchange with capillary.

Nonelectronic Temperature Controls

Freezer compartment temperature is regulated by air sensing thermostat at top rear of fresh food compartment which actuates compressor. Control capillary is inserted in well which routes capillary into freezer. Control should be set to maintain freezer temperature between -17° to -18°C .

Fresh food compartment temperature is regulated an air damper control governing amount of refrigerated air entering fresh food compartment from freezer. Fresh food compartment temperature should be between 3° and 4°C .

Electronic Control

Electronic control is not repairable. If any component in control is faulty, entire control must be replaced.

NOTE: Repair or replace all faulty line voltage components before testing or replacing electronic control. Do not assume problems are caused by electronic control system. Opened, shorted, earthed or otherwise faulty line voltage components (including power cord and wiring) can create problems that appear to be caused by electronic control.

Refrigerated Chiller Fresh Deli Drawer

Chiller Fresh system is a deli drawer in a sleeve. Control on inner wall of fresh food compartment allows freezer air to circulate into sleeve maintaining temperature $4^{\circ}\text{C} \pm 1^{\circ}$ colder than fresh food compartment.

Boot must be in place over air inlet. Set to maintain desired temperature in deli drawer.

Beverage Chiller

Control on left inner wall of fresh food compartment allows freezer air to circulate into beverage chiller maintaining temperature up to 3°C colder than fresh food compartment. Valve on outside wall of refrigerator door allows freezer air to pass to beverage chiller.

Fresh food compartment temperature can be affected by additional cold air so freezer temperature control may need adjustment after beverage chiller temperature is set.

Product Design



WARNING

To avoid risk of electrical shock, personal injury, or death, disconnect electrical power source to unit and discharge capacitor through a 10,000 ohm resistor before attempting to service, unless test procedures require power to be connected. Ensure all earth wires are connected before certifying unit as repaired and/or operational.

Defrost System—Nonelectronic Models

Every 6 or 8 hours of compressor run time defrost timer activates radiant electric defrost heater suspended from evaporator. After 33 minutes of defrost cycle time, timer restores circuit to compressor.

Defrost terminator (thermostat) and fusible link are wired in series with defrost heater and evaporator fan motor. Terminator opens and breaks circuit when preset high temperature is reached. After defrost thermostat opens, thermostat remains open until end of defrost cycle until cooling cycle starts and terminator senses present low temperature and closes.

Fusible link opens if terminator fails open and preset high temperature is reached.

Defrost heater is suspended on left side of evaporator coil and across bottom to keep defrost drain free flowing during defrost. Defrost water is caught in trough under evaporator coil and flows through drain hole in liner and drain tubing into drain pan. Heated air circulated by condenser fan over pan evaporates water.

Defrost System—Electronic Models

See "Electronic Functional Description."

Service Procedures



WARNING

To avoid risk of electrical shock, personal injury, or death, disconnect electrical power source to unit and discharge capacitor through a 10,000 ohm resistor before attempting to service, unless test procedures require power to be connected. Ensure all earth wires are connected before certifying unit as repaired and/or operational.

Service Equipment

Listed below is equipment needed for proper servicing of HFC134a systems. Verify equipment is confirmed by manufacturer as being compatible with HFC134a and ester oil system.

Equipment must be exclusively used for HFC134a. Exclusive use of equipment only applies to italic items.

- **Evacuation pump**

Check with vacuum pump supplier to verify equipment is compatible for HFC134a. Robinair, Model 15600, 2 stage, 170 litres (6 cubic feet) per minute pump is recommended.

- ***Four-way manifold gauge set, with low loss hoses***

- **Leak detector**

- ***Charging cylinder***

- ***Line piercing saddle valve***

(Schroeder valves). Seals must be HFC134a and ester oil compatible. Line piercing valves may be used for diagnosis but are not suitable for evacuation or charging, due to minute holes pierced in tubing. Do not leave mechanical access valves on system. Valves eventually will leak. Molecules of HFC134a are smaller than other refrigerants and will leak where other refrigerants would not.

- ***Swagging tools***

- ***Flaring tools***

- ***Tubing cutter***

- **Flux**

- **Sil-Fos**

- **Silver solder**

- ***Oil for swagging and flaring***

Use only part #R0157532

- ***Copper tubing***

Use only part #R0174075 and #R0174076

- **Dry nitrogen**

99.5% minimum purity, with -40°C (-40°F) or lower dew point

- **Crimp tool**

- **Tube bender**

- **Micron vacuum gauge**

- ***Process tube adaptor kit***

- **Heat trap paste**

- ***ICI appliance grade HFC134a***

Drier Replacement

Prior to opening refrigeration system, recover HFC134a refrigerant for safe disposal.

Every time sealed HFC134a system is repaired, drier filter must be replaced with, part # B2150504.

Cut drier out of system by completing the following steps. Do not unbraid drier filter. Applying heat to remove drier will allow moisture into system.



WARNING

To avoid death or severe personal injury, cut drier at correct location. Cutting drier at incorrect location will allow desiccant beads to scatter. Completely clean area of beads, if spilled.

1. Score capillary tube close to drier and break.
2. Reform inlet tube to drier allowing enough space for large tube cutter.
3. Cut circumference of drier at 3 cm (1-1/4"), below condenser inlet tube joint to drier.
4. Remove drier.
5. Apply heat trap paste on post condenser tubes to protect grommets from high heat.
6. Unbraid remaining part of drier. Remove drier from system.
7. Discard drier in safe place. Do not leave drier with customer. If refrigerator is under warranty, old drier must accompany warranty claim.

Service Procedures



WARNING

To avoid risk of electrical shock, personal injury, or death, disconnect electrical power source to unit and discharge capacitor through a 10,000 ohm resistor before attempting to service, unless test procedures require power to be connected. Ensure all wires are connected before certifying unit as repaired and/or operational.

Refrigerant Precautions



WARNING

To avoid personal injury, do not allow refrigerant to contact eyes or skin.



CAUTION

To avoid risk of property damage, do not use refrigerant other than that shown on unit serial number identification plate.

NOTE: All precautionary measures recommended by refrigerant manufacturers and suppliers apply and should be observed.

Line Piercing Valves

Line piercing valves can be used for diagnosis, but are not suitable for evacuating or charging due to holes pierced in tubing by valves.

NOTE: Do not leave line piercing valves on system. Connection between valve and tubing is not hermetically sealed. Leaks will occur.

Open Lines

During any processing of refrigeration system, never leave lines open to atmosphere. Open lines allow water vapor to enter system, making proper evacuation more difficult.

Compressor Operational Test

(short term testing only)

If compressor voltage, capacitor, overload, and motor winding tests are successful (do not indicate a fault), perform the following test:

1. Disconnect power to unit.
2. Discharge capacitor by shorting capacitor terminals through a resistor.
3. Remove leads from compressor terminals.
4. Attach test cord to compressor windings.
 - Common lead on test cord attaches to C terminal on compressor.
 - Start lead on test cord attaches to S terminal on compressor.

- Run lead on test cord attaches to M terminal on compressor.

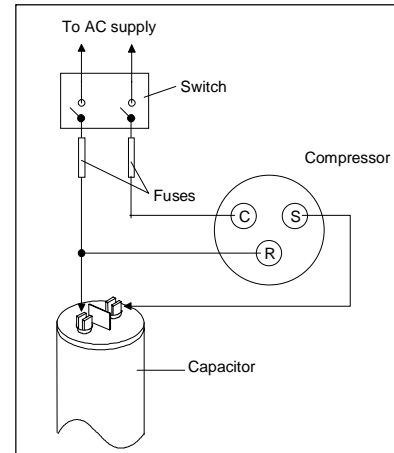

Attaching Capacitor for Compressor Test

5. Connect a known good capacitor into circuit as shown above. For proper capacitor size and rating, see Technical Sheet for unit under test.

NOTE: Ensure test cord cables and fuses meet specifications for unit under test (see Technical Sheet for unit under test).

6. Replace compressor protector cover securely.
7. Plug test cord into outlet, then press and release start cord switch.



CAUTION

To avoid damage to compressor windings, immediately disconnect (unplug) test cord from power source if compressor does not start. Damage to compressor windings occurs if windings remain energized when compressor is not running.

If compressor runs when direct wired, it is working properly. Malfunction is elsewhere in system.

If compressor does not start when direct wired, recover system at high side. After the system is recovered, repeat compressor direct wire test.

If compressor runs after system is recovered (but would not operate when wired direct before recovery) a restriction in sealed system is indicated.

If motor does not run when wired direct after recovery, replace faulty compressor.

Service Procedures



WARNING

To avoid risk of electrical shock, personal injury, or death, disconnect electrical power source to unit and discharge capacitor through a resistor before attempting to service, unless test procedures require power to be connected. Ensure all earth wires are connected before certifying unit as repaired and/or operational.

Dehydrating Sealed Refrigeration System

Moisture in a refrigerator sealed system exposed to heat generated by the compressor and motor reacts chemically with refrigerant and oil in the system and forms corrosive hydrochloric and hydrofluoric acids. These acids contribute to the breakdown of motor winding insulation and corrosion of compressor working parts, causing compressor failure.

In addition, sludge, a residue of the chemical reaction, coats all surfaces of sealed system, and will eventually restrict refrigerant flow through capillary tube.

To dehydrate sealed system, evacuate system (see paragraph **Evacuation**).

Leak Testing



DANGER

To prevent serious injury or death from violent explosions, NEVER use oxygen or acetylene for pressure testing or clean out of refrigeration systems. Free oxygen will explode on contact with oil. Acetylene will explode spontaneously when put under pressure.

It is important to check sealed system for refrigerant leaks. Undetected leaks can lead to repeated service calls and eventually result in system contamination, restrictions, and premature compressor failure.

Refrigerant leaks are best detected with halide or electronic leak detectors.

Testing Systems Containing a Refrigerant Charge

1. Stop the operation (turn refrigerator off).
2. Holding leak detector exploring tube as close to system tubing as possible, check all piping, joints, and fittings.

NOTE: Use soap suds on areas leak detector cannot reach or reliably test.

Testing Systems Containing No Refrigerant Charge

1. Connect cylinder of nitrogen, through gauge manifold, to process tube of compressor and liquid line strainer.
2. Open valves on nitrogen cylinder and gage manifold. Allow pressure to build within sealed system.
3. Check for leaks using soap suds.

If a leak is detected in a joint, do not to attempt to repair by applying additional brazing material. Joint must be disassembled, cleaned and rebrazed. Capture refrigerant charge (if system is charged), unbrazed joint, clean all parts, then rebraze.

If leak is detected in tubing, replace tubing. If leak is detected in either coil, replace faulty coil.

Service Procedures



WARNING

To avoid risk of electrical shock, personal injury, or death, disconnect electrical power source to unit and discharge capacitor through a 10,000 ohm resistor before attempting to service, unless test procedures require power to be connected. Ensure all earth wires are connected before certifying unit as repaired and/or operational.

Restrictions

Symptoms

Restrictions in sealed system most often occur at capillary tube or filter drier, but can exist anywhere on liquid side of system.

Restrictions reduce refrigerant flow rate and heat removal rate. Wattage drops because compressor is not circulating normal amount of refrigerant.

Common causes of total restrictions are moisture, poorly soldered joints, or solid contaminants. Moisture freezes at evaporator inlet end of capillary tube. Solid contaminants collect in filter drier.

If restriction is on low side, suction pressure will be in a vacuum and head pressure will be near normal

If restriction is on high side, suction pressure will be in a vacuum and head pressure will be higher than normal during pump out cycle.

Refrigeration occurs on low pressure side of partial restriction. There will be a temperature difference at the point of restriction. Frost and/or condensation will be present in most case at the point of restriction.

Also, system requires longer to equalize.

Slight or partial restriction can give the same symptoms as refrigerant shortage including lower than normal back pressure, head pressure, wattage, and warmer temperatures.

Total restriction on the discharge side of compressor when restriction is between compressor and first half of condenser results in higher than normal head pressure and wattage while low side is being pumped out.

Testing for Restrictions

To determine if a restriction exists:

1. Attach gauge and manifold between suction and discharge sides of sealed system.
2. Turn unit on and allow pressure on each side to stabilize. Inspect condenser side of system. Tubing on condenser should be warm and temperature should be equal throughout (no sudden drops at any point along tubing).
 - If temperature of condenser tubing is consistent throughout, go to step 4.

- If temperature of condenser tubing drops suddenly at any point, tubing is restricted at point of temperature drop (if restriction is severe, frost may form at point of restriction and extend down in direction of refrigerant flow in system). Go to step 5.
3. Visually check system for kinks in refrigeration line which is causing restriction. Correct kink and repeat step 2.
 4. Turn unit off and time how long it takes high and low pressure gauges to equalize:
 - If pressure equalization takes longer than 10 minutes, a restriction exists in the capillary tube or drier filter. Go to step 5.
 - If pressure equalization takes less than 10 minutes, system is not restricted. Check for other possible causes of malfunction.
 5. Recover refrigerant in sealed system.
- NOTE:** Before opening any refrigeration system, capture refrigerant in system for safe disposal.
6. Remove power from unit.



CAUTION

To reduce risk of personal injury or property damage, take necessary precautions against high temperatures required for brazing.

7. Remove and replace restricted device.
8. Evacuate sealed system.
9. Charge system to specification.

NOTE: Do not use captured or recycled refrigerant in Amana units. Captured or recycled refrigerant voids any Amana and/or compressor manufacturer's warranty.

NOTE: Charge system with exact amount of refrigerant. See Technical Sheet or refer to unit nameplate for correct refrigerant charge. Inaccurately charged system will cause future problems.

Service Procedures



WARNING

To avoid risk of electrical shock, personal injury, or death, disconnect electrical power source to unit and discharge capacitor through a 10,000 ohm resistor before attempting to service, unless test procedures require power to be connected. Ensure all earth wires are connected before certifying unit as repaired and/or operational.

Evacuation and Charging



CAUTION

To avoid risk of fire, sealed refrigeration system must be air free. To reduce risk of air contamination, follow evacuation procedures exactly.

NOTE: Before opening any refrigeration system, EPA regulations require refrigerant in system to be captured for safe disposal.

Proper evacuation of sealed refrigeration system is an important service procedure. Usable life and operational efficiency greatly depends upon how completely air, moisture and other non-condensables are evacuated from sealed system.

Air in sealed system causes high condensing temperature and pressure, resulting in increased power requirements and reduced performance.

Moisture in sealed system chemically reacts with refrigerant and oil to form corrosive hydrofluoric and hydrochloric acids. These acids attack motor windings and parts, causing premature breakdown.

Before opening system, evaporator coil must be at ambient temperature to minimize moisture infiltration into system.

Evacuation

To evacuate sealed refrigeration system:

1. Connect vacuum pump, vacuum tight manifold set with high vacuum hoses, thermocouple vacuum gauge and charging cylinder as shown in illustration. Evacuation should be done through I.D. opening of tubes not through line piercing valve.
2. Connect low side line to compressor process tube.
3. Connect high side line to drier/process tube.
4. Evacuate both simultaneously. With valve "C" and "F" closed, open all other valves and start vacuum pump.

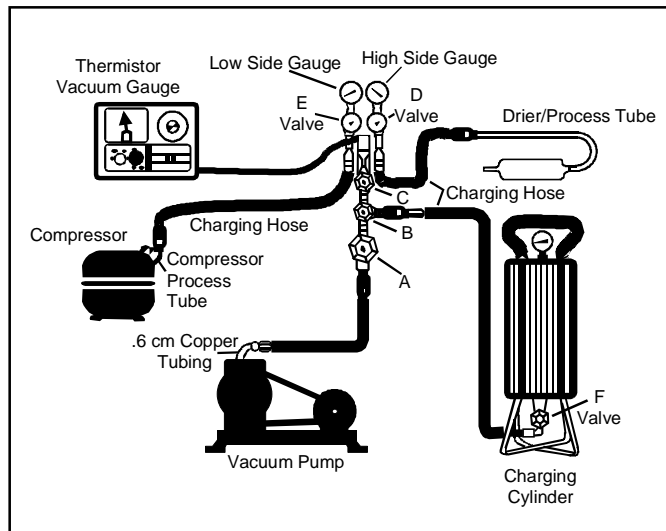

Equipment Setup For Evacuation And Charging

5. After compound gauge (low side) drops to approximately 29 inches gauge, open valve "C" to vacuum thermocouple gauge and take micron reading.

NOTE: A high vacuum pump can only produce a good vacuum if oil in pump is not contaminated.

6. Continue evacuating system until vacuum gauge registers 600 microns.
7. At 600 microns, close valve "A" to vacuum pump and allow micron reading in system to balance. Micron level will rise.
 - If in 2 minutes, micron level stabilizes at 1000 microns or below, system is ready to be charged.
 - If micron level rises above 1000 microns and stabilizes, open valve "A" and continue evacuating.
 - If micron reading rises rapidly and does not stabilize, a leak still exists in system.

Close valve "A" to vacuum pump and valve "C" to vacuum gauge. Invert charging cylinder and open charging cylinder valve "F" to add partial charge for leak checking. With leak detector, check manifold connections and system for leaks. After locating leak, capture refrigerant, repair leak, and begin at step 1.

Service Procedures



WARNING

To avoid risk of electrical shock, personal injury, or death, disconnect electrical power source to unit and discharge capacitor through a 10,000 ohm resistor before attempting to service, unless test procedures require power to be connected. Ensure all earth wires are connected before certifying unit as repaired and/or operational.

Charging

NOTE: Do not use captured or recycled refrigerant in Amana units. Captured or recycled refrigerant voids any warranty.

NOTE: Charge system with exact amount of refrigerant. See Technical Sheet or refer to unit serial plate for correct refrigerant charge. Inaccurately charged system will cause future problems.

To charge system:

1. Close valves "A" to vacuum pump and "C" to vacuum gauge and "E" to low side manifold gauge.
2. Set scale on dial-a-charge cylinder for corresponding HFC134a pressure reading.
3. Open valve "F" to charging cylinder and let exact amount of refrigerant flow from cylinder into system. Close valve.
Low side gauge pressure should rise shortly after opening charging cylinder valve as system pressure equalizes through capillary tube.
If pressure does not equalize, a restriction typically exists at capillary/drier braze joint.
4. If pressure equalizes, open valve "E" to low side manifold gauge and pinch off high side drier process tube.
5. Start compressor and draw remaining refrigerant from charging hoses and manifold into compressor through compressor process tube.
6. To check high side, pinch-off drier process tube. Close valve "D" to high side gauge. If high side pressure rises, repeat high side pinch-off and open valve "D". Repeat until high side pinch-off does not leak.
7. Pinch-off compressor process tube and remove charging hose. Braze stub closed while compressor is operating.
8. Disconnect power. Remove charging hose and braze high side drier process tube closed.
9. Recheck for refrigerant leaks.

Refrigerant Charge

Refrigerant charge in all capillary tube systems is critical and exact amount is required for proper performance. Factory charges are shown on serial plate. Do not use refrigerant other than shown on serial plate.

Service Procedures



WARNING

To avoid risk of electrical shock, personal injury, or death, disconnect electrical power source to unit and discharge capacitor through a 10,000 ohm resistor before attempting to service, unless test procedures require power to be connected. Ensure all earth wires are connected before certifying unit as repaired and/or operational.

HFC134a Service Information

HFC134a is alternative refrigerant for CFC12. HFC134a has an ozone depletion potential (ODP) factor of 0.0 and a global warming potential (GWP) factor of 0.27. HFC134a is not flammable and has acceptable toxicity levels. HFC134a is not interchangeable with CFC12. There are significant differences between HFC134a and CFC12 which must be considered when handling and processing refrigeration system.

Health, Safety, and Handling

Health, safety and handling considerations for HFC134A are virtually no different than those for CFC12.

Health, Safety, and Handling	CFC12	HFC134a
Allowable overall exposure limit	1,000 ppm	Same
Vapor exposure to skin	No effect	Same
Liquid exposure to skin	Can cause frostbite	Same
Vapor exposure to eye	Very slight eye irritant	Same
Liquid exposure to eye	Can cause frostbit	Same
Above minimum exposure limit	Can cause Asphyxiation, Tachycardia, and Cardia Arrhythmias	Same
Safety and handling	Wear appropriate skin and eye protection. Use with adequate ventilation.	Same
Spill management	Remove or extinguish ignition or combustion sources. Evacuate or ventilate area.	Same
Fire explosion hazards	May decompose if contact with flames and heating elements. Container may explode if heated due to resulting pressure rise. Combustion products are toxic.	Same
Disposal procedures	Recycle or reclaim.	Same

Comparison of CFC12 and HFC134a Properties

Properties/Characteristics	CFC12	HFC134a
Ozone Depletion Potential (ODP)	1.0*	0.0*
Global Warming Potential (GPW)	3.2*	0.27*
Molecular weight	121	102
Boiling point at 1 atmosphere	-22°F (-30°C)	-15°F (-26°C)
Vapor pressure at 77°F (25°C)	80 psig	82 psig
Liquid density at 77°F (25°C)	82 lb/ft ³	75 lb/ft ³
Flammability	No	No
High-side system operating Pressure at 65°F (18°C)	HFC134a approximately 3 psig higher than CFC12	
Low-side system operating Pressure at 65°F (18°C)	HFC134a approximately 2 psig lower than CFC12	



Caution

To minimize contamination, exercise extreme care when servicing HFC134A sealed systems.

- No trace of other refrigerants is allowed in HFC134a systems. Chlorinated molecules in other refrigerants such as CFC12, etc. will lead to capillary tube plugging.
- Ester oil is used in HFC134a systems. Do not use mineral oil. HFC134a and mineral oils cannot be mixed. If mineral oils were used in HFC134a systems, lubricant would not return to compressor and would cause early compressor failure. If significant amount of oil has been lost from compressor, replace oil rather than adding oil.
- Ester oils used in HFC134a systems are so hydroscopic that by the time an inadequate system performance is detected, oil will be saturated with moisture.
- CFC12 has much higher tolerance to system processing materials, such as drawing compounds, rust inhibitors, and cleaning compounds, than HFC134a. Such materials are not soluble in HFC134a systems. If materials were to be washed from system surfaces by ester oils, they could accumulate and eventually plug capillary tube.
- Care must be taken to minimize moisture from entering HFC134a system. Do not leave compressor or system open to atmosphere for more than 10 minutes. Excessive moisture in HFC134a system will react with compressor oil and generate acid.
- Compressor must be replaced when performing low side leak repair.
- Drier filter must always be replaced with service drier filter, part #B2150504.

Important: Unbrazing drier filter from tubing will drive moisture from desiccant and into system, causing acids to form. Do not unbraid filter drier from tubing. If CFC12 service drier was installed in HFC134A system, drier could overload due to excessive moisture.

- HFC134a compatible copper tubing, part #R0174075 and part #R0174076 must be used when replacing tubing.
- Avoid system contamination by using Towerdraw E610 evaporating oil, part # R0157532, when flaring, swagging, or cutting refrigeration tubing.

Service Procedures



WARNING

To avoid risk of electrical shock, personal injury, or death, disconnect electrical power source to unit and discharge capacitor through a 10,000 ohm resistor before attempting to service, unless test procedures require power to be connected. Ensure all earth wires are connected before certifying unit as repaired and/or operational.

Replacement Service Compressor

HFC134a service compressors will be charged with ester oil and pressurized with dry nitrogen. Before replacement compressor is installed, pull out 1 rubber plug. A *pop* from pressure release should be heard. If a *pop* sound is not heard, do not use compressor. Positive pressure in compressor is vital to keep moisture out of ester oil. Do not leave compressor open to atmosphere for more than 10 minutes.

Compressor Testing Procedures



WARNING

To avoid death or severe personal injury, never use oxygen, air or acetylene for pressure testing or clean out of refrigeration system. Use of oxygen, air, or acetylene may result in violent explosion. Oxygen may explode on contact with oil and acetylene will spontaneously explode when under pressure.

Refer to "Temperature and Relationship Chart" for operating watts, test points, and temperature relationship test.

- Temperature testing is accomplished by using 3 lead thermocouple temperature tester in specific locations. Test point T-1 is outlet on evaporator coil and T-2 is inlet. Test point T-3 is suction tube temperature midway between where armaflex ends and suction port of compressor (approximately 12 inches from compressor).
- Thermocouple tips should be attached securely to specified locations.
- Do not test during initial *pull down*. Allow one off cycle or balanced temperature condition to occur before proceeding with testing.
- Refrigerator must operate minimum of 20 minutes after thermocouples are installed.
- Turn control to colder to obtain required on time.
- Wattage reading must be recorded in conjunction with temperature test to confirm proper operation.
- Suction and head pressures are listed on "Temperature and Relationship Chart" Normally these are not required for diagnosis but used for confirmation on systems which have been opened.

Brazing



CAUTION

To reduce risk of personal injury or property damage, take necessary precautions against high temperatures required for brazing.

Satisfactory results require cleanliness, experience, and use of proper materials and equipment.

Connections to be brazed must be properly sized, free of rough edges, and clean.

Generally accepted brazing materials are:

- **Copper to copper joints:** SIL-FOS (alloy of 15 percent silver, 80 percent copper, and 5 percent phosphorous). Use without flux. Recommended brazing temperature is approximately 760°C (1400°F). **Do not use for copper to steel connection.**
- **Copper to steel joints:** SILVER SOLDER (alloy of 30 percent silver, 38 percent copper, 32 percent zinc). Use with fluoride based flux. Recommended brazing temperature is approximately 649°C (1200°F).
- **Steel to steel joints:** SILVER SOLDER (see copper to steel joints).
- **Brass to copper joints:** SILVER SOLDER (see copper to steel joints).
- **Brass to steel joints:** SILVER SOLDER (see copper to steel joints).

Checking Electric Heater Assembly

1. Disconnect power to unit.
2. Ensure heater element is cold, then remove suspect heater and visually inspect element for obvious damage (breaks, cracks in element, etc.).
3. Attach ohmmeter to element leads. Check for continuity (see tech sheet for unit under test).

If element reads open (infinite or very high resistance):

4. Check disc type thermostat for continuity (see tech sheet for open and close values). If open replace.

Refrigerant Flow

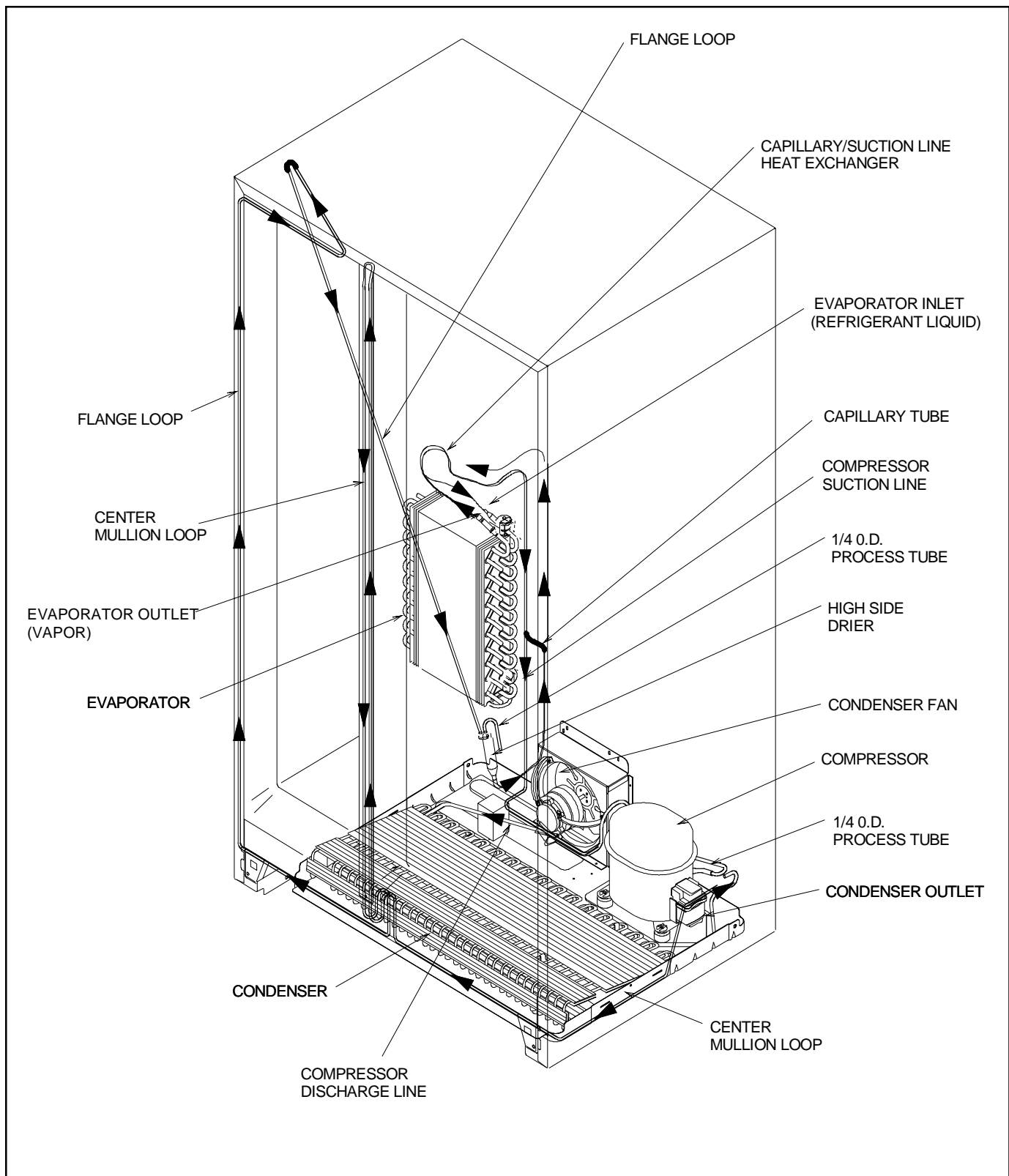

**“T” Model Side x Side
Refrigerant Flow Diagram
22/25/27 Cubic Foot Only**

Refrigerant Flow

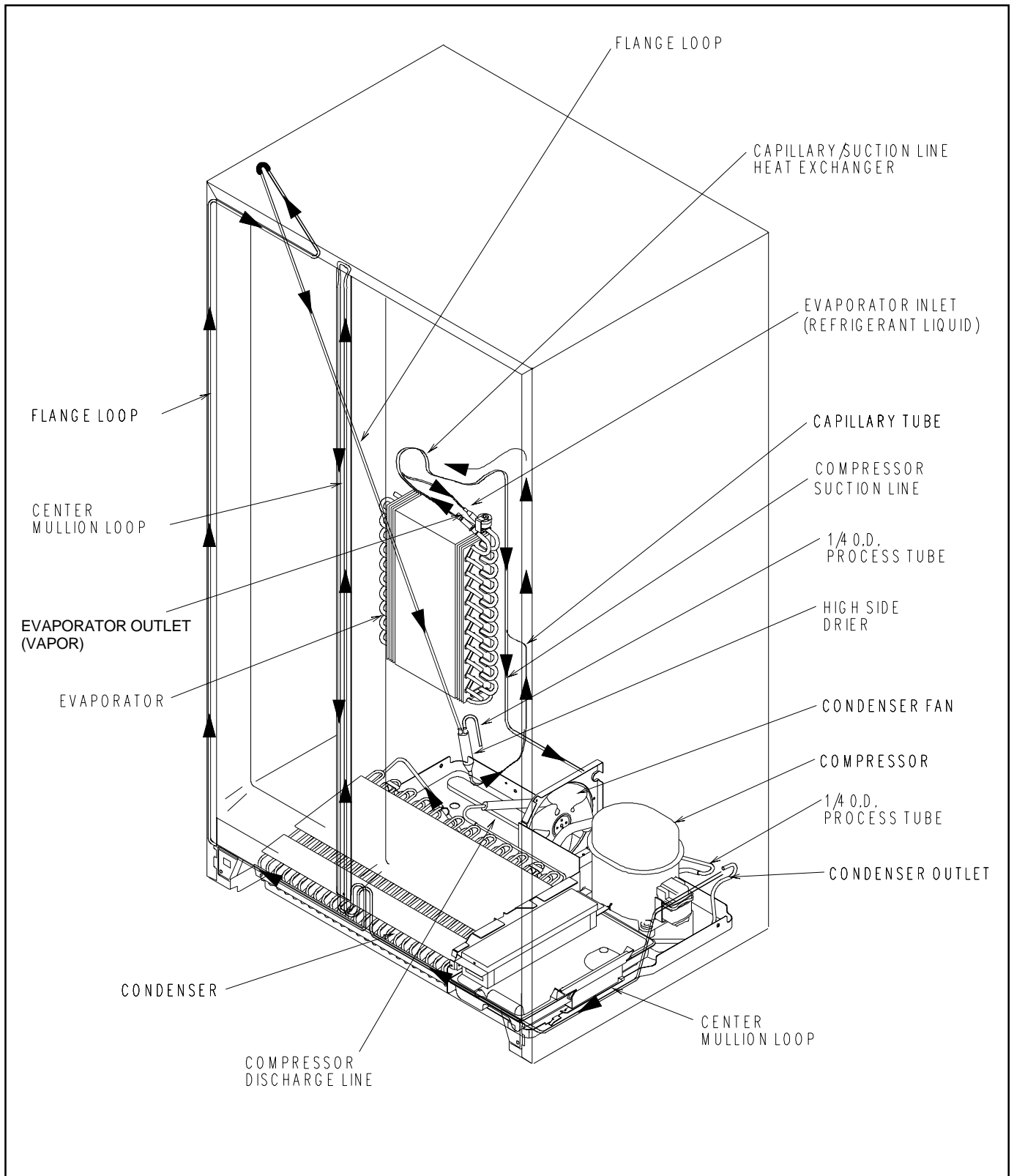

**“T” Model Side x Side
Refrigerant Flow Diagram
20 Cubic Foot Only**

Cabinet Air Flow

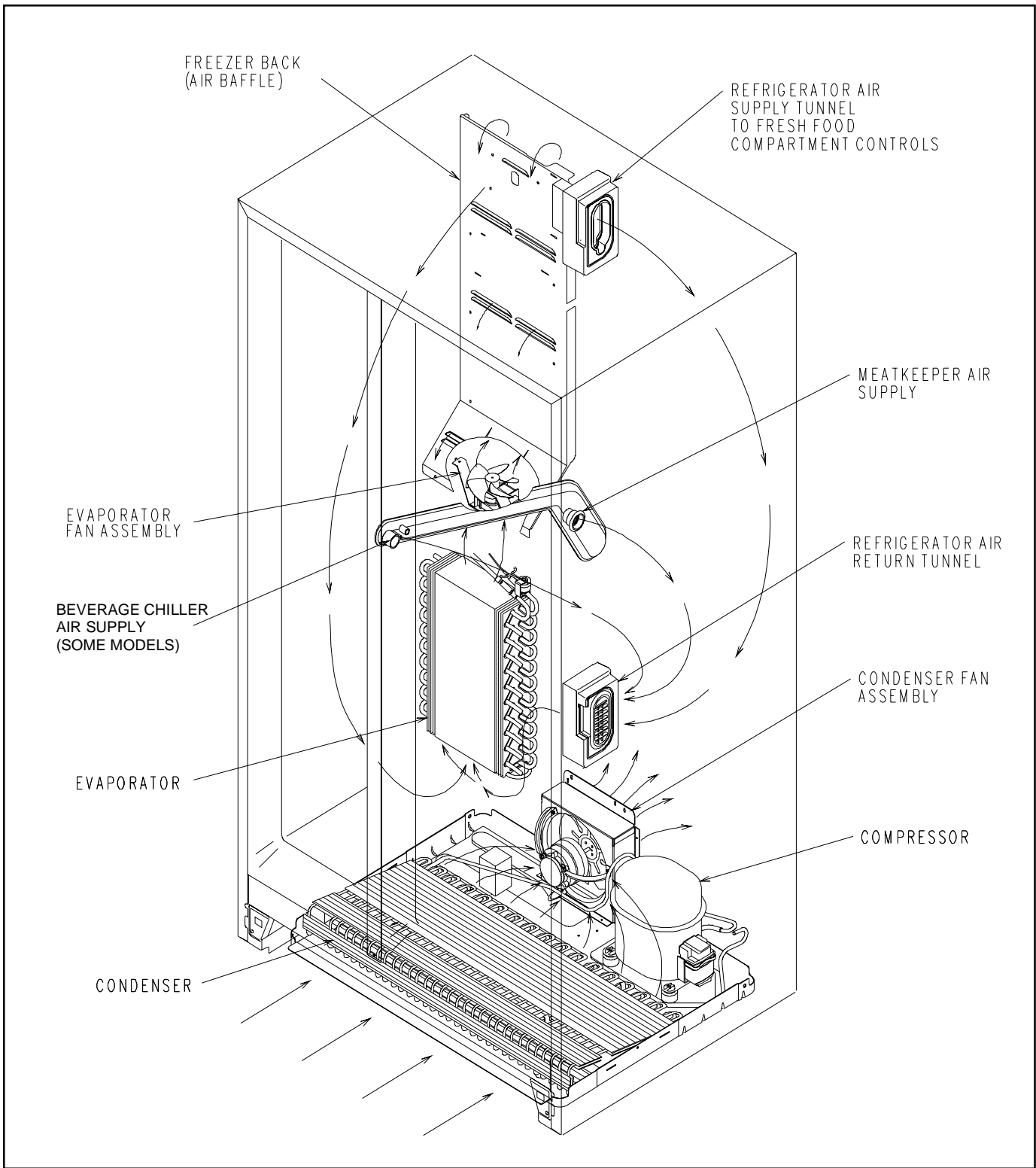

**"T" Model Side x Side
Air Flow Diagram
22/25/27 Cubic Foot Only**

Cabinet Air Flow

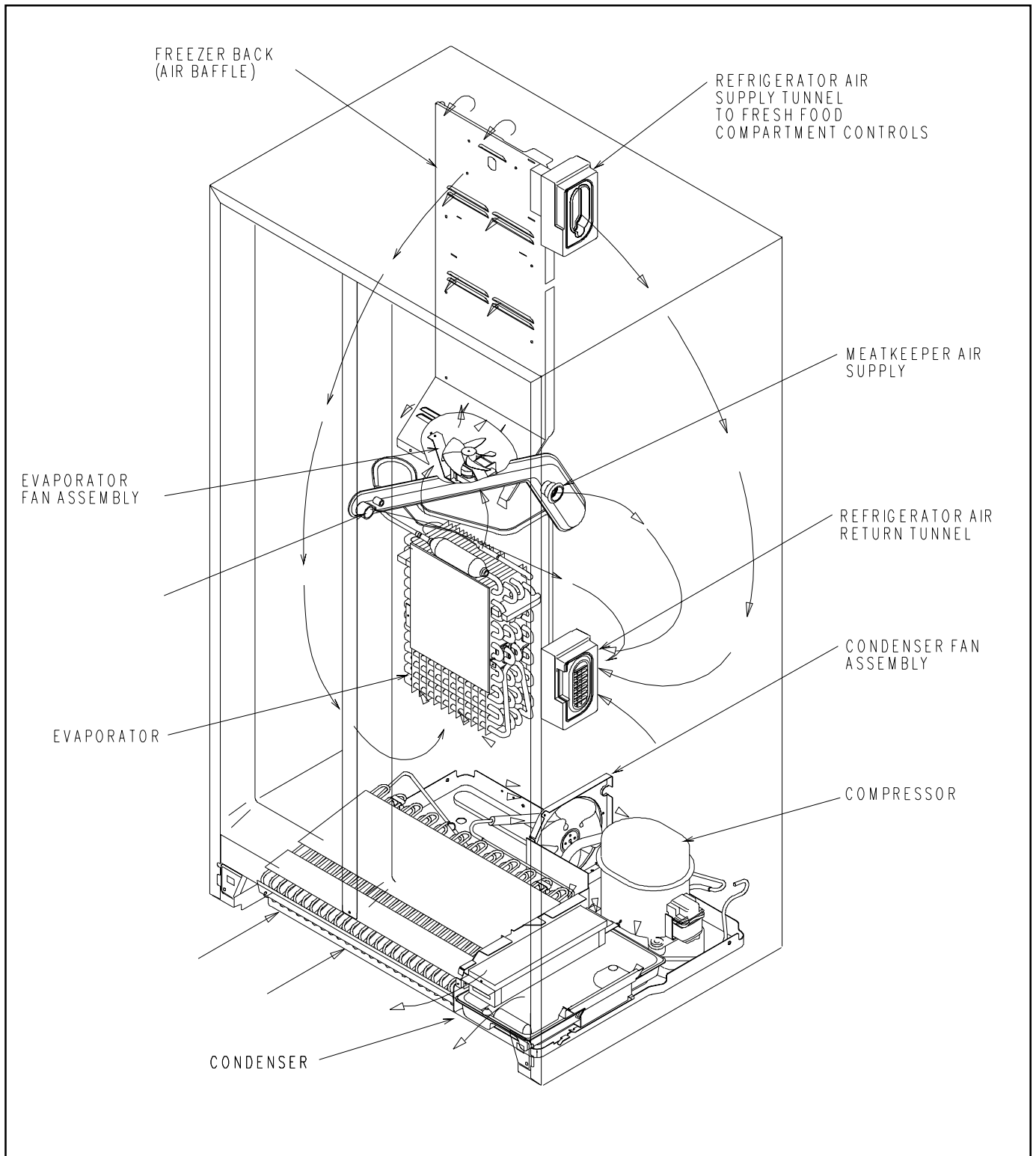

**"T" Model Side x Side
Air Flow Diagram
20 Cubic Foot Only**

Water Flow

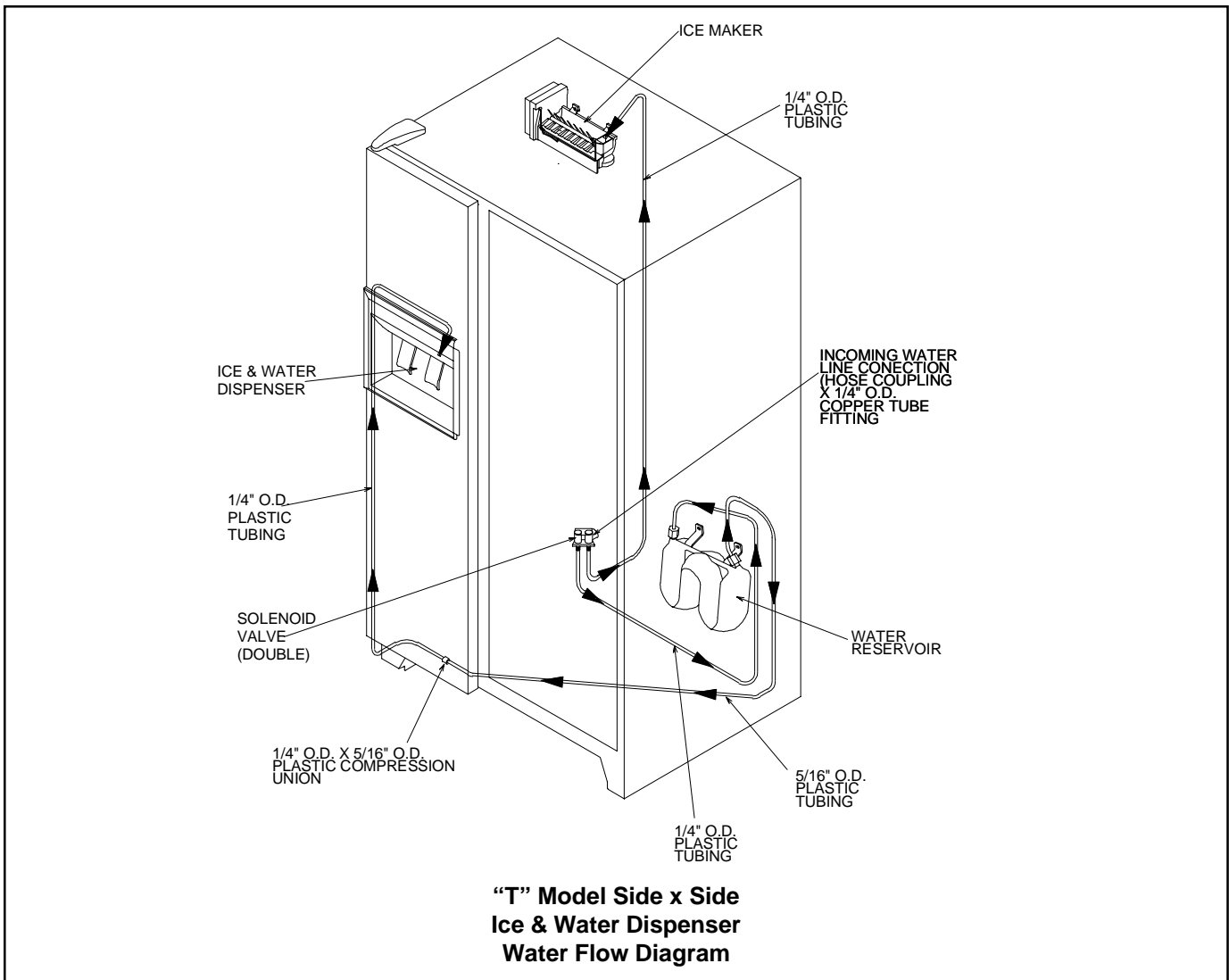

Dispenser Water Temperature Chart

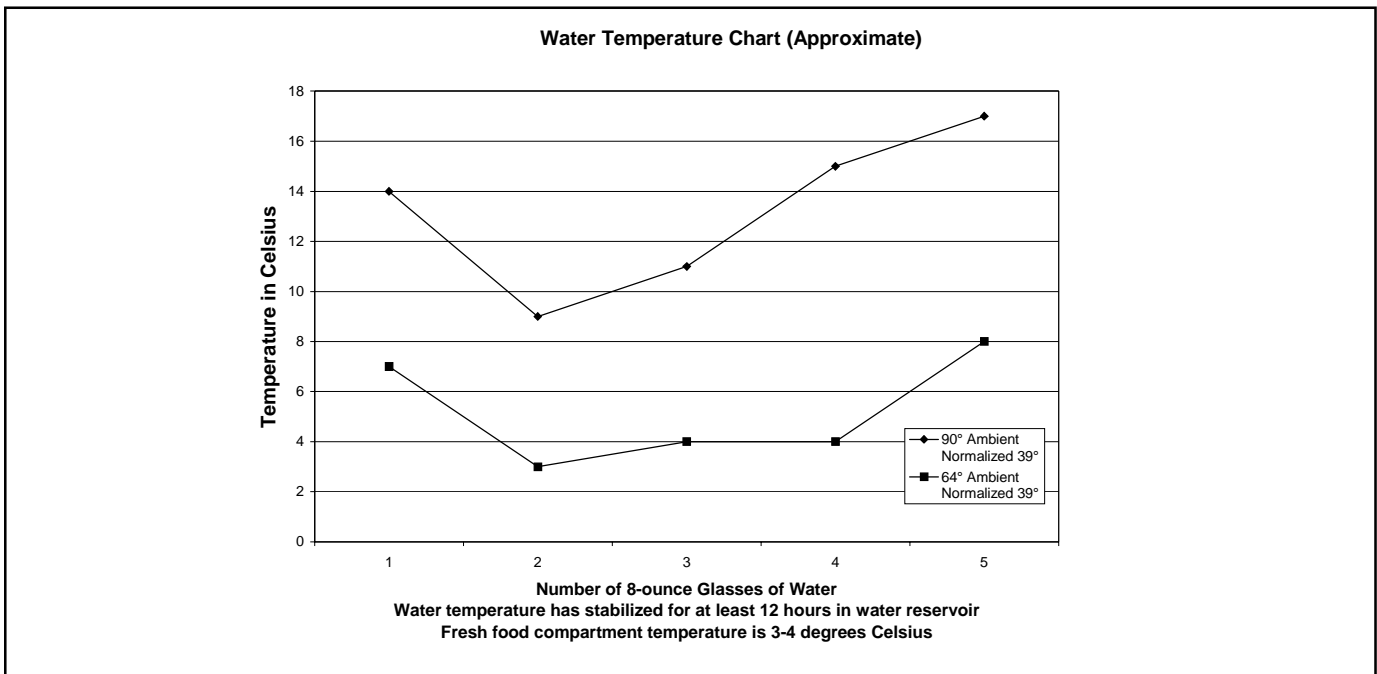

Typical External Sweat Pattern

CLASSIFICATION OF CONDENSATION
1=Haze or Fog
2=Beading
3=Beads or small drops
4=Drops running together

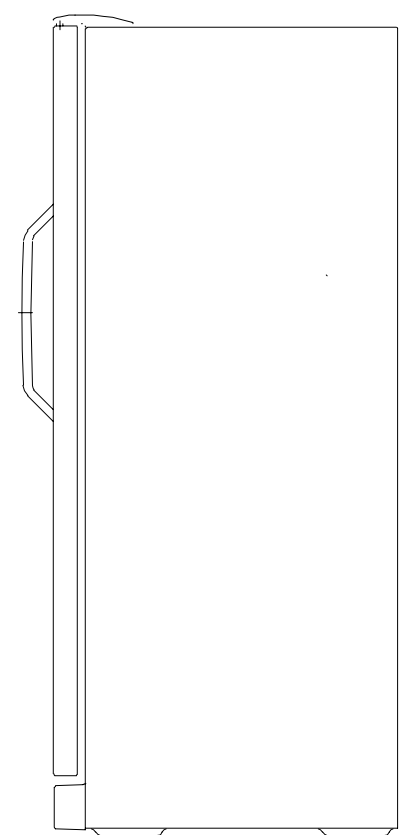
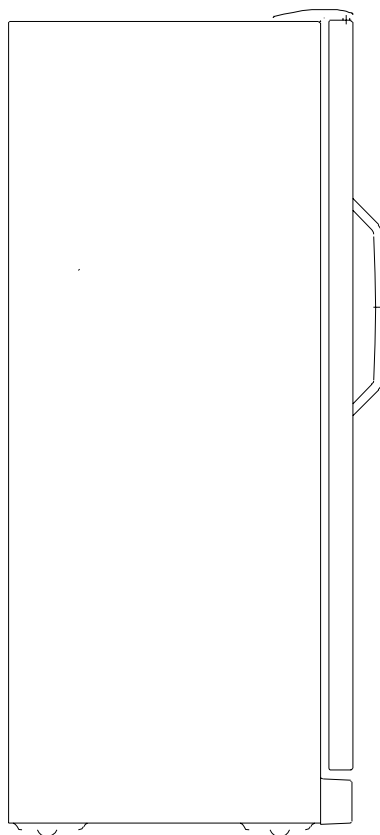
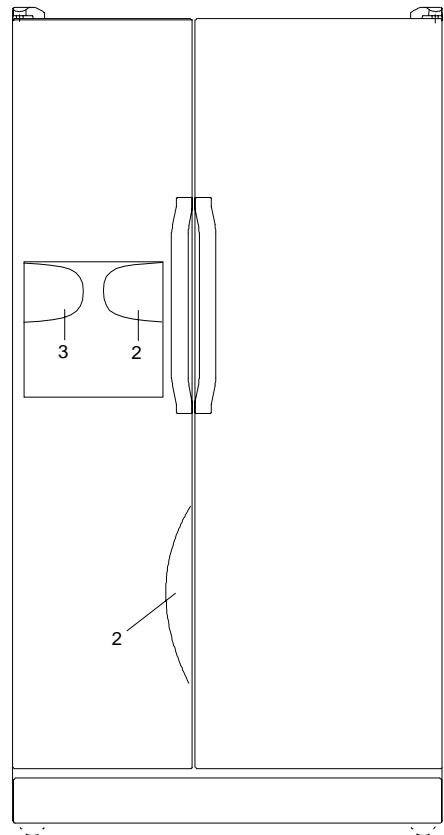
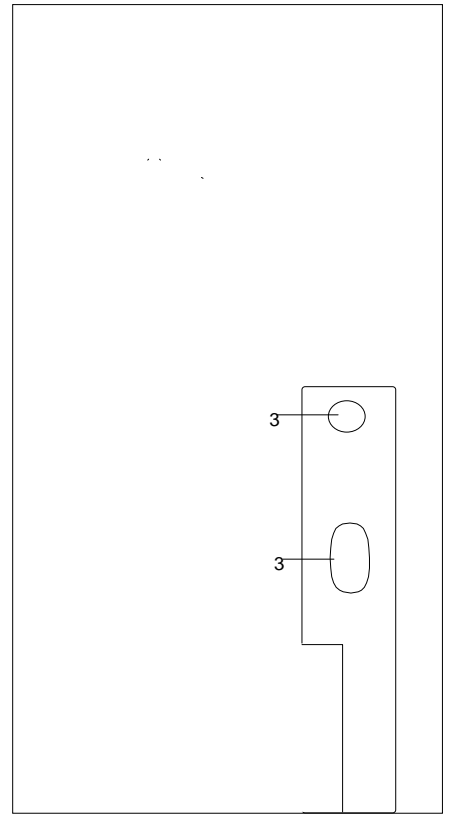
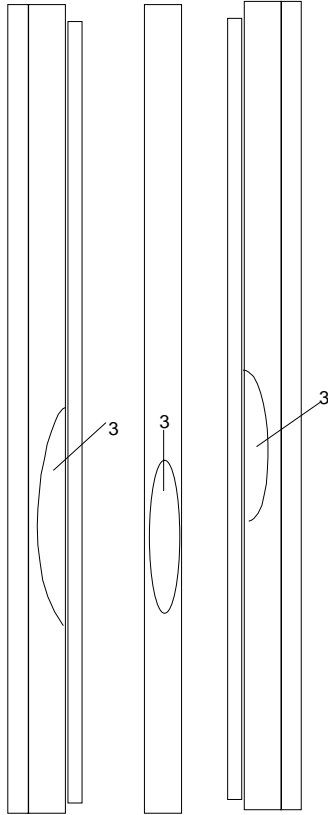
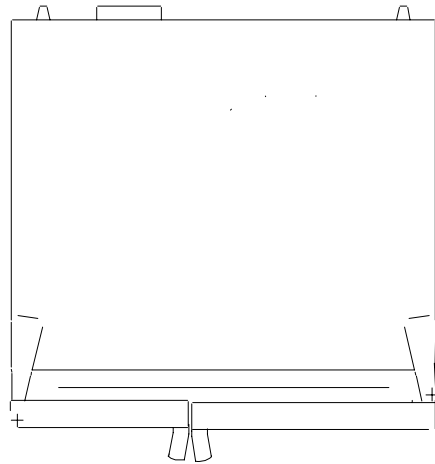
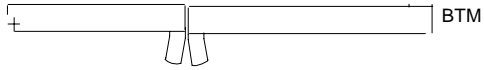

Disassembly



WARNING

To avoid risk of electrical shock, personal injury, or death, disconnect electrical power source to unit and discharge capacitor through a resistor before attempting to service, unless test procedures require power to be connected. Ensure all earthing wires are connected before certifying unit as repaired and/or operational.

Freezer or Refrigerator Door

1. Remove toe grille.

Electronic Models

2. Unplug wiring harness from voltage box.

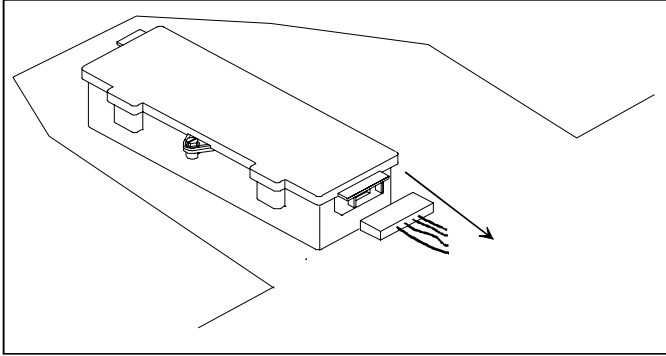

High Voltage Box

Dispenser Models

3. Loosen water tube clamp screw. Loosen plastic water tube union nut. Pull water tube away from union nut and through tube clamp.

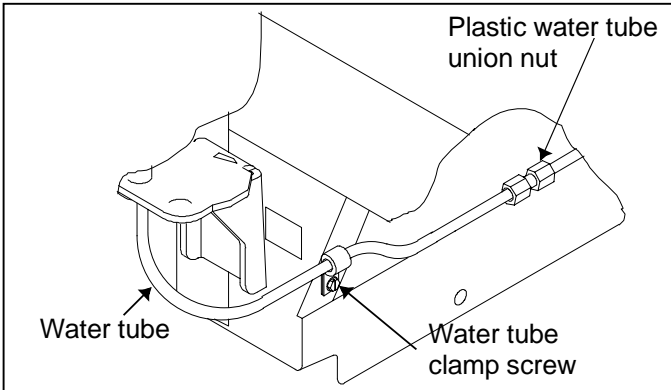

Water Tube Connection

Door Stop and Top Door Closure

1. Remove door from cabinet.
2. Remove screw mounting top door closure.
3. Remove two screws mounting door stop to bottom edge of door.

Freezer Door Top Hinge

1. Secure freezer door to cabinet in closed position with strapping tape.



CAUTION

To prevent personal injury or property damage due to door falling, always secure door to cabinet with strapping tape before top hinge is removed.

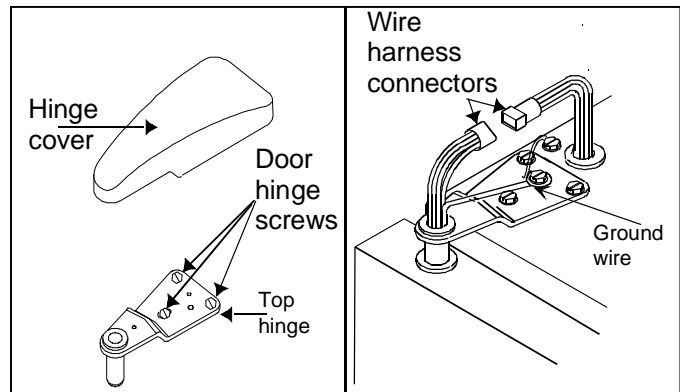

2. Remove freezer hinge cover.
3. Unplug cabinet to freezer door wiring harness connector blocks.
4. Remove earthing screw and three freezer hinge to cabinet mounting screws.
5. If present, slide hinge and nylon door bushing out of door and off freezer door wiring harness.

Combination Door Closure and Lower Hinge

1. Remove door from cabinet.
2. Remove one bottom door closure mounting screw and remove closure.
3. Remove two hinge mounting screws and door hinge.



WARNING

To avoid risk of electrical shock, personal injury, or death, disconnect electrical power source to unit and discharge capacitor through a resistor before attempting to service, unless test procedures require power to be connected. Ensure all earthing wires are connected before certifying unit as repaired and/or operational.

Freezer Door Wiring Harness (All Non-electronic Dispenser Models)

NOTE: Freezer door wiring harness on electronic models is foamed into place at factory and is not replaceable as a separate part.

1. After removing door, remove inner door liner, cavity styrofoam cavity liner and insulation around cavity.
2. Locate wiring harness inside place sleeve along handle flange of door.
3. Attach a string or wire to wiring harness going through top hinge. Pull string through as harness is removed.

NOTE: For reassembly, pull new harness into place through plastic sleeve using string to guide new harness.

Freezer Door Water Tube

1. Remove freezer door.
2. Remove inner door liner
3. Locate water tube next to left flange of door. Water tube runs inside large plastic sleeve.
4. Free tube from cavity and slide water tube down and out through hole in door closure.

Refrigerator Door

Refrigerator door wiring harness on some models is foamed into place in door and is not replaceable.

1. Remove toe grille.
2. Disconnect 12-pin connector from high voltage board.
3. Remove refrigerator door top hinge cover and unplug wire connector.
4. Remove earthing wire screw.
5. With refrigerator door open, remove single screw mounting door closure to top of bottom hinge.
6. With refrigerator door closed, remove three top hinge screws and pull wiring harness through hinge.
7. Lift door about 3 inches to allow lower door closure to clear hinge pin.
8. Carefully rest bottom edge of door on protective pad while removing hinge pin which press fits into refrigerator bottom hinge bracket.

NOTE: On electronic models when replacing bottom door bushing, hinge pin, or door extract low voltage wiring from connector at high voltage board. The wiring colors and corresponding pin connector numbers are shown below.

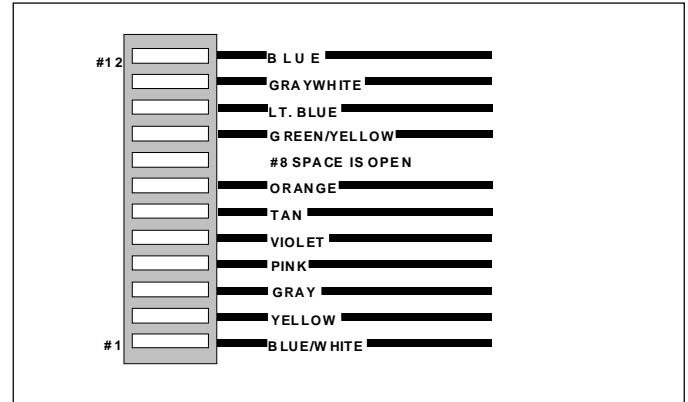

A straightened standard size paper clip can be used to push pins down and out of connector to release wires.

When reinstalling pins, make certain pins lock into connector. It may be necessary to gently pry up on pin before reinstalling to assure it locks into connector when reinstalled.

Refrigerator Door Handle (Built-in and Electronic Models)

1. Remove top and bottom caps by pulling away from door handles.
2. Remove plastic insert by sliding insert up and out of door handle.
3. Remove seven mounting screws from handle and lift handle away from door.

NOTE: On electronic models, carefully disconnect control ribbon connector from low voltage board.

Refrigerator or Freezer Handle (Free Standing Models)

1. Unsnap top and bottom door handle trim by carefully prying up under outside edge of trim to release trim from retainer.

NOTE: Be careful to catch trim pieces located between trim strips and door handle.

2. Remove door handle by removing two screws, exposed after trim is removed.



WARNING

To avoid risk of electrical shock, personal injury, or death, disconnect electrical power source to unit and discharge capacitor through a resistor before attempting to service, unless test procedures require power to be connected. Ensure all earthing wires are connected before certifying unit as repaired and/or operational.

Handle Side Door Trim Retainers

1. Remove door trim by prying up carefully under outside edge of retainer.
2. Remove phillips mounting screws.

Door Gasket

1. Remove door.
2. Place door face down on a protected surface with door handle extending beyond the edge of surface.
3. Lift gasket away from door and loosen all mounting screws.
4. Pull gasket out and away from door liner.

Inner Door Liner

1. Remove door.
2. Place door face down on a protected surface with door handle extending beyond edge of surface.

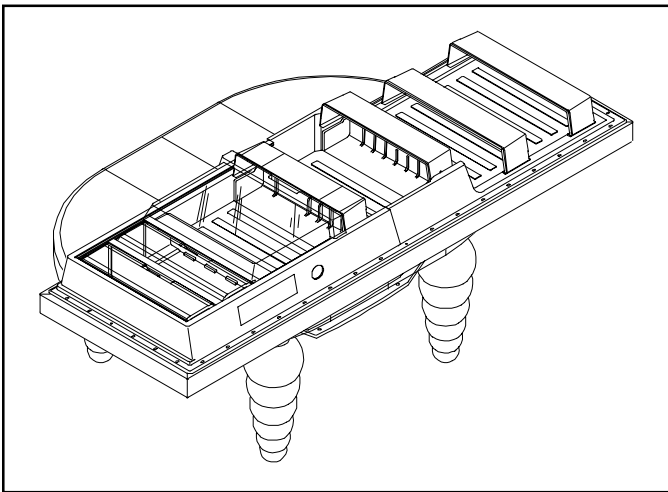

Door Position to Remove Inner Door Liner

3. Lifting gasket away from the door, remove all mounting screws, retainers (freezer door only), and gasket.

Low Voltage Board

1. Remove door handle.
2. Remove four mounting screws holding circuit board to refrigerator door.
3. Tilt board and pull board from cavity.
4. Unplug connector from board by inserting flat blade screwdriver in either end of connector and pry apart.

NOTE: Do not try to unplug connector by pulling on wire harness.

Ice and Water Cavity

1. Remove escutcheon by removing two phillips screws at bottom of escutcheon and lifting escutcheon off.
2. Remove electric mounting bracket by removing mounting screws at each side of plate.
3. Remove ten screws securing perimeter of cavity to door.
4. Pull out top of cavity slightly exposing where waterline held in notch by washer type clip.
5. Push electrical grommet back and out of cavity hole in left side of cavity.
6. Tip cavity out at top and lift slightly so cavity sump clears bottom edge of opening.

Cavity Heater

1. After removing cavity, unplug cavity heater from door harness.
2. Carefully peel cavity heater off back of cavity.

Electrical Mounting Bracket

1. Remove escutcheon by removing two phillips mounting screws at bottom of escutcheon and lifting escutcheon off.
2. Remove mounting screws at each side of plate.
3. Separate bracket from cover to access Ice Dispenser Switch, Water Dispenser Switch, Cavity Light Switch, Cavity heater Switch, Cube/Crushed Switch, and Cavity light bulb.

Water Actuator Arm

1. Remove escutcheon and electrical mounting bracket.
2. Remove two screws and two retainers.
3. In reassembly, return spring straddles arm and rides up against top section of arm.

Ice Actuator Arm

1. Remove escutcheon and electrical mounting bracket.
2. Remove two screws and the two retainers.
3. Slide arm down and out from under chute door while disconnecting door closure delay mechanism.

Door Closure Delay Mechanism (Ice and Water Models)

1. Remove one screw.
2. Disconnect from ice actuator arm and remove.

Chute Door (Ice and Water Models)

1. Remove escutcheon, electrical bracket, and ice actuator arm.
2. Remove two screws to remove chute door, spring, and hinge from cavity.
3. To separate chute door from hinge, remove pin.

Disassembly



WARNING

To avoid risk of electrical shock, personal injury, or death, disconnect electrical power source to unit and discharge capacitor through a resistor before attempting to service, unless test procedures require power to be connected. Ensure all earthing wires are connected before certifying unit as repaired and/or operational.

Cabinet Components

Refrigerator Temperature Control

1. Remove control knobs (nonelectronic models).
2. Loosen bracket on bottom left of cover to allow cover to be rotated forward.
3. Pull bottom of cover out until it unsnaps. Continue tilting cover out until top tabs release and remove cover.
4. Remove insulation over top of damper.
5. Remove styrofoam filler piece from control body exposing two mounting screws.
6. Remove mounting screws to remove control.

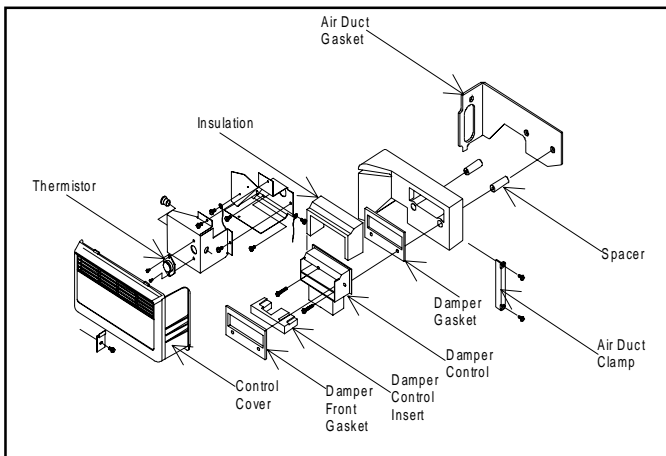

Electronic Models Temperature Control

Freezer Temperature Control (Nonelectronic Models)

1. Remove control knobs.
 2. Loosen brace on bottom left of cover to allow cover to be rotated forward.
 3. Pull bottom of cover out until it unsnaps. Continue tilting cover out until top tabs release and remove cover.
 4. Remove two control mounting screws.
 5. Remove sealer from control capillary well.
- NOTE:** Replace sealer during reassembly.
6. Pull control out of bracket.
 7. Disconnect wiring from rear of control.
 8. Remove capillary from well and remove control.

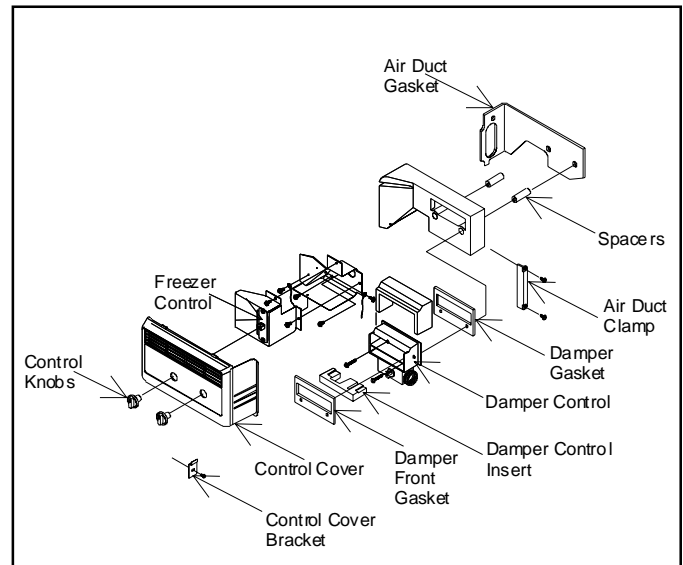

Non-electronic Models Temperature Control

Refrigerator Light Switch

1. Remove two screws on rear corners of lens.
2. Remove two screws located on front of shield, behind trim piece.
3. Remove two screws on rear of light shield and slide shield back until released.
4. Slide switch mounting plate back until released from refrigerator top.
5. Remove wiring to switch.
6. Press in on tab located on the opposite side of electrical tabs and push switch through mounting plate.

Freezer Light/Auger Motor Interlock Switch

1. Remove two mounting screws from plate.
2. Slide switch mounting plate back until released.
3. Remove wiring to switch.
4. Press in on tabs and push switch through mounting plate.

Disassembly



WARNING

To avoid risk of electrical shock, personal injury, or death, disconnect electrical power source to unit and discharge capacitor through a resistor before attempting to service, unless test procedures require power to be connected. Ensure all earthing wires are connected before certifying unit as repaired and/or operational.

Refrigerator Light Lens and Light Bulbs



CAUTION

To avoid risk of burns, be sure bulb is cool before removing.

1. Remove two mounting bolts on rear corners of lens.
2. Loosen two mounting bolts on front of lens behind trim piece.
3. Slide lens back until it releases from mounting bolts.

NOTE: Bulbs are standard base screw in type 25 watt appliance bulbs.

Refrigerator Light Socket

1. Remove two mounting bolts on rear corners of lens.
2. Loosen two mounting bolts on front of lens behind trim piece.
3. Slide lens back until it releases from mounting bolts.
4. Remove wiring to socket.
5. Socket snaps out of shield by pressing on two tabs on top and bottom of socket.

Freezer Light Bulb, Light Socket.



CAUTION

To avoid risk of burns, be sure bulb is cool before removing.

1. Remove ice bucket (if applicable).
2. Remove lens top mounting screw and remove lens by lifting up.

NOTE: Bulbs are standard base screw in type 25 watt appliance bulbs.

3. Remove two plate mounting screws from behind facade and pull facade and mounting plate away from freezer ceiling.
4. Disconnect wiring to socket.
5. Remove socket by pressing on tabs on either side of socket.

Center Mullion

Center mullion is not replaceable.

Freezer Wire Shelf and Shelf Retainers

1. Maneuver stops around retainers and pull wire shelves or baskets out from retainers.
2. Grasp retainer firmly and slide up until released.

Freezer Basket Slide Retainer

- Remove two mounting screws and remove retainer.

Evaporator

Freezer Evaporator Cover

1. Remove freezer shelves, freezer basket, ice service rack, and icemaker.
2. Remove 1/4" hex head mounting screws on evaporator cover.
3. Push ice maker electrical block through opening in panel. Remove panel.

Freezer Thermistor (Electronic Models)

1. Remove eight 1/4" hex head screws retaining evaporator cover.
2. Remove leads.
3. Remove thermistor by removing 2 screws.

Defrost Thermostat (Terminator)

1. Remove eight 1/4" hex head screws retaining evaporator cover.
2. Unclip thermostat from outlet on evaporator coil.
3. Disconnect leads.
4. Slide clamps from around evaporator tubing and remove thermostat.

Evaporator Defrost Heater

1. Remove evaporator cover and thermistor, if necessary.
2. Remove one 1/4" hex head screw from left side of coil and 2 from right side.
3. Remove defrost thermostat.
4. Tip bottom of evaporator coil out.
5. Remove 2 wire clips.
6. Slide heater down and out from coil.
7. Unplug heater leads.

Disassembly



WARNING

To avoid risk of electrical shock, personal injury, or death, disconnect electrical power source to unit and discharge capacitor through a resistor before attempting to service, unless test procedures require power to be connected. Ensure all earthing wires are connected before certifying unit as repaired and/or operational.

Evaporator

NOTE: Evaporator and heat exchanger must be replaced as an assembly.

Reclaim refrigerant before proceeding with evaporator removal. To avoid refrigeration system contamination, do not leave refrigeration system or compressor open for more than 10 minutes.

1. Remove evaporator cover and thermistor, if necessary.
2. Remove one 1/4" hex head screw from left side of coil and 2 from right side.
3. Remove defrost thermostat.
4. Remove defrost heater by removing wire clips holding heater to bottom of evaporator coils.
5. Remove machines compartment and heat exchanger covers.

NOTE: On some models special driver (part #92113P01) will be necessary to remove screws securing heat exchanger cover.

6. Shield interior components from heat source and unbraid suction tube at compressor.
7. Score and break capillary tube at drier.
8. Straighten heat exchanger and pull evaporator out of plastic clips holding it to back wall of unit. Pull evaporator and heat exchanger through front of refrigerator as a unit.

NOTE: If styrofoam block on outer case back wall is damaged during evaporator removal, seal damaged area with mastic sealer.

Evaporator Fan Motor

1. Remove ice bucket and freezer shelves.
2. Remove freezer back panel.
3. Remove two 5/16" hex head screws from evaporator fan motor mounting bracket.
4. Maneuver motor/bracket from housing.
5. Remove lead and earthing wires.
6. Remove two 1/4" hex head screws from brackets.

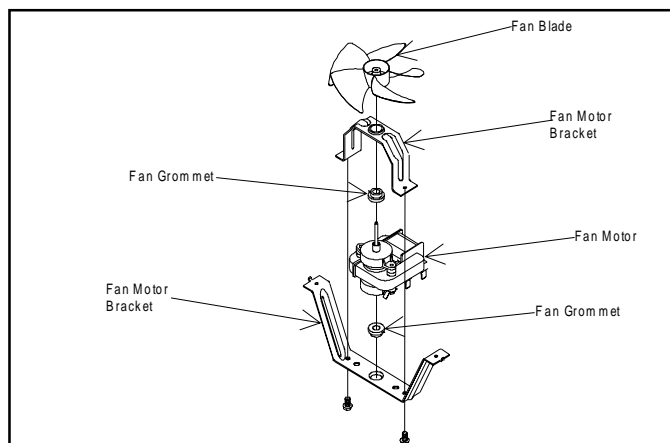

Evaporator Fan

Evaporator Fan Blade

1. See Evaporator Fan Motor steps 1-4.
2. Pull fan blade off motor shaft. When replacing fan blade, 1.2 cm (1/2") of motor shaft should extend through hub of fan blade.

Auger Motor (Ice and Water Models)

1. Remove ice bucket.
2. Remove left-handed locking nut from motor shaft.
3. Remove motor mounting bracket cover by removing two mounting screws.
4. Remove four bolts securing motor to auger motor support and back motor out of bracket. Remove leads from motor.

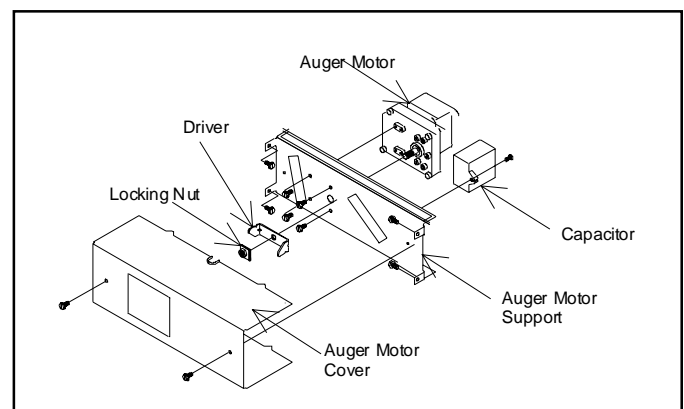

Auger Motor

Front Roller Assembly

Refrigerator can not be installed when replacing roller assembly.

1. Remove toe grille
2. Raise front of refrigerator 10 cm (4") from floor.
3. Remove two hex head screws mounting roller brack housing.
4. Remove leveling bolt and disassemble housing from roller bracket assembly.

Rear Roller Assembly

1. Remove machine compartment cover.
2. Raise left or right side of refrigerator on 10 cm (4") block.
3. Remove #27 torx bolt going up through rear rail and into bottom of cabinet foot.
4. Drop rail slightly and slide roller pin towards outside of cabinet and out of rail.

Disassembly



WARNING

To avoid risk of electrical shock, personal injury, or death, disconnect electrical power source to unit and discharge capacitor through a resistor before attempting to service, unless test procedures require power to be connected. Ensure all earthing wires are connected before certifying unit as repaired and/or operational.

Water Valve

1. Remove machine compartment cover and heat exchanger cover on rear of unit.

NOTE: On some models special driver (part #92113P01) will be necessary to remove screws securing heat exchanger cover.

2. Disconnect water supply.
3. Remove brass nuts at water valve inlet and outlet.
4. Pull copper tubing from water valve. Anti-kink springs are installed in plastic tubing connecting to valve.

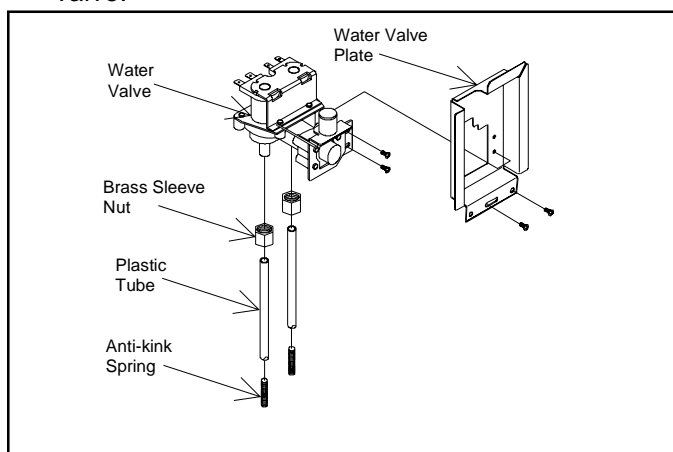

Water Valve

5. Unplug wiring harness.

Water Tank (Ice and Water Models)

Before removing water tank have container available to catch contents of water tank.

1. Remove shelves and drawers in refrigerator and unsnap top of tank cover and remove cover. OR
2. Remove four screws mounting machine compartment air baffle.
3. Remove water lines by loosening two B-nuts securing water lines to tank.
4. Remove two tank mounting screws at top of tank.

Shelf Support Ladders

1. Remove shelves
2. Remove four #15 torx screws for each ladder.

Machine Compartment

1. Remove machine compartment cover on rear of unit and heat exchanger cover.

Note: Some models have two tamper resistant screws and will require special driver part #92113P01 to remove.

Note: Always recover refrigerants before any sealed system component repair or replacement. Replace drier when performing a sealed system repair with Amana drier.

2. Remove one bolt from left and one bolt from right of compressor base pan.
3. Pull compressor base pan slowing towards rear reforming tubing carefully as necessary to avoid kinking and pinching.
4. Pull pan out a maximum of approximately 20 cm (8") from rear. This will allow compressor to be removed, leak check of all condenser joints, and/or replacement or cleaning of condensate pan. Pulling pan out more than 20 cm (8") will drop base pan off front glide rail.

Condensate Drain Pan (20 Cubic Foot Models Only)

Before removing drain pan, have towels ready to absorb condensation.

1. Remove toe grille.
2. Pull pan forward.

Condensate Drain Pan (All Other Models)

1. Remove machine compartment cover on rear of unit and heat exchanger cover.
2. Remove one bolt from left and one bolt from right of compressor base pan.
3. Pull compressor base pan slowing towards rear reforming tubing carefully as necessary to avoid kinking and pinching.
4. Pull pan out a maximum of approximately 20 cm (8") from rear. Reform tubing as necessary to avoid kinking and pinching.
5. Condensate drain pan clips into place on top of condenser. Release from tabs on condenser by pulling drain pan up.



WARNING

To avoid risk of electrical shock, personal injury, or death, disconnect electrical power source to unit and discharge capacitor through a resistor before attempting to service, unless test procedures require power to be connected. Ensure all earthing wires are connected before certifying unit as repaired and/or operational.

Compressor

1. See *Machine Compartment, Condenser, Condenser Fan Access*.

Note: Always replace drier when repairing refrigeration system. Wear eye protection.

2. See *Overload and Relay*
3. Remove two screws securing condenser fan shroud to outer case back, if necessary.
4. Unclip machine compartment wire harness from condenser fan shroud and drier/filter from its metal clip.
5. Capture refrigerant charge.
6. Remove four 7/16" hex head shoulder bolts mounting compressor to machine compartment floor.
7. Unbraze suction and discharge tubing from compressor.
8. Remove earthing wire screw to compressor.
9. Disconnect electrical leads at overload and relay.

Low Voltage Board

1. See *Low and High Voltage Board and Showroom Switch Access*.
2. Remove 4 Phillips screws.
3. Disconnect edge connector from right edge of board.
4. Take readings at low voltage board.

High Voltage Board

1. Remove toe grille.

NOTE: The high voltage board is in the high voltage board box mounting on the side of condenser on 20 cubic foot models and on front of condenser on 27 cubic foot models.

2. Remove the mounting screw holding high voltage board cover to chassis. Mounting screw on 20 cubic foot models is at front of mounting box. Mounting screw on 27 cubic foot models is on right of mounting box.



WARNING

To avoid electrical shock which can cause severe personal injury or death, discharge capacitor before handling.

3. Slide box forward (20 cubic foot) or to right until box rear clip disengages from condenser.
4. Pull box out front of unit.

5. Carefully, remove wiring and harness from board.
6. Transfer wiring from old board to replacement board.
7. Remove mounting screws securing high voltage board to box.

Power Switch (Electronic Models Only)

Power switch at front of high voltage box interrupts circuit to high voltage board.

1. See *High Voltage Box*.
2. Remove two screws mounting protective flap and switch to high voltage box.
3. Disconnect leads from switch.

Compressor Run Capacitor (Fan Shroud Mounted)

1. Remove compressor compartment rear cover and heat exchanger cover.

NOTE: On some models special driver (part #92113P01) will be necessary to remove screws securing heat exchanger cover.

2. Remove two screws securing condenser fan shroud to out case back.
3. Unclip machines compartment wire harness from condenser fan shroud and unclip drier.
4. Remove one bolt from left and one bolt from right of compressor base pan.
5. Pull compressor base pan slowly towards rear reforming tubing carefully as necessary to avoid kinking and pinching.
6. Pull pan out a maximum of approximately 20 cm (8") from rear. This will allow compressor to be removed, leak checking of all condenser joints, and/or replacement or cleaning of condensate pan. Pulling pan out more than 20 cm (8") will drop base pan off front glide rail.
7. Disconnect wiring to capacitor.



WARNING

To avoid electrical shock which can cause severe personal injury or death, discharge capacitor before handling.

8. Remove nut securing capacitor to shroud and remove capacitor.



WARNING

To avoid risk of electrical shock, personal injury, or death, disconnect electrical power source to unit and discharge capacitor through a resistor before attempting to service, unless test procedures require power to be connected. Ensure all earthing wires are connected before certifying unit as repaired and/or operational.

Compressor Run Capacitor (Control Housing Mounted)

1. Remove toe grille.
2. Remove mounting screw securing timer/capacitor housing to condenser.
3. Remove top from housing by removing screw securing top to housing.
4. Disconnect wiring to capacitor.



WARNING

To avoid electrical shock which can cause severe personal injury or death, discharge capacitor before handling.

5. Remove nut securing capacitor to housing and remove capacitor.

Overload and Relay

1. See *Compressor, Condenser, Condenser Fan Access*.
2. Remove bale strap from compressor terminal cover and remove cover.
3. Remove electrical leads from overload and relay.
4. Pull overload lead off compressor common terminal and pull relay off compressor start and run terminals.

Condenser Fan Blade

1. See *Compressor, Condenser, Condenser Fan Access*.
2. Remove nut from motor shaft.
3. Remove fan blade. Replace rubber washer behind fan blade when reassembling.

Condenser Fan Motor

1. See *Condenser Fan Blade*
2. Remove compressor electrical cover and remove both motor leads from overload and relay and earthing wires.
3. Remove three hex head screws mounting motor to

brackets.

Condenser

1. See *Compressor, Condenser, Condenser Fan Access*.
2. See *Condenser Fan Motor*, steps 1-3.

Note: Condenser is only available as assembly with base pan.

Drain Tube

1. Remove machine compartment rear cover and heat exchanger cover.

NOTE: On some models special driver (part #92113P01) will be necessary to remove screws securing heat exchanger cover.

2. Remove two screws securing condenser fan shroud out case back, if necessary.
3. Unclip machine compartment wire harness from condenser fan shroud. Unclip drier.
4. Remove one bolt from left and one bolt from right side of compressor compartment pan.
5. Slide compressor compartment out rear of unit approximately 8 cm (3").
6. Remove "P" clamps attaching drain tube to the ceiling of machine compartment.
7. Pull drain tube off nipple in machine compartment ceiling.

Ice Maker

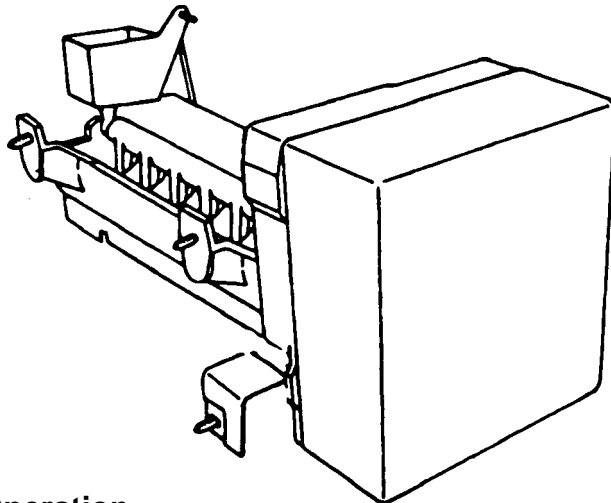

Operation

When the thermostat has sensed temperature $-8.3^{\circ} \pm 1.5^{\circ} \text{C}$ ($17^{\circ} \pm 3^{\circ} \text{F}$), the thermostat closes. The current now has a path through the thermostat to the motor (see wiring diagram). The motor is linked with the drive gear. From the module, there are copper contacts that ride on copper strips on backside of drive gear. As the drive gear rotates, these contacts will make or break a circuit (tract) to the copper strips to operate the ice maker.

The design of the ice maker allows all of the components to be tested without removing the ice maker or moving the refrigerator away from the wall to access the water valve.

Remove the cover and you will see the test points identified on the module.

- N = Neutral side of line
- M = Motor connection
- H = Heater Connection
- T = Thermostat connection
- L = L1 side of line
- V = Water valve connection

NOTE: Read this section completely before doing any testing or adjusting.

The test holes are identified as *N*, *M*, *V*, etc.

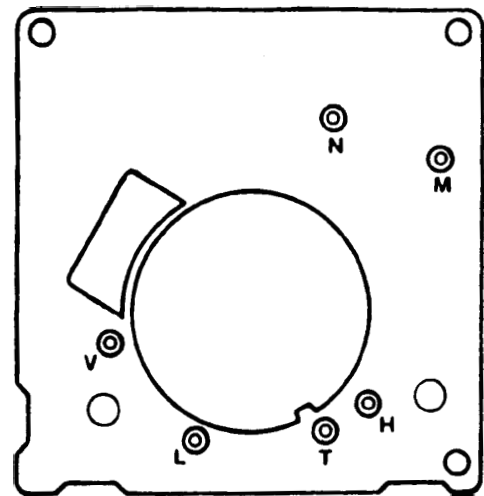

Specifications

Mold Heater	- 185 Watts, 264 Ohms
Thermostat (Bimetal)	- Close $-8 \pm 1^{\circ} \text{C}$ ($17 \pm 3^{\circ} \text{F}$) Opens $0^{\circ} \pm 1^{\circ} \text{C}$ ($17 \pm 3^{\circ} \text{F}$)
Water Fill	- 140 cc, 7.5 Sec.
Motor Cycle	- Stamped in Circuit, Plug in Connectors, One Revolution of blades take three minutes plug stall time on ice. (Eject and Water Fill)

Testing Procedures

Ice maker plugged into power, shut-off arm down, freezer cold

1. Test point *L* and *N* will verify 230 volts to Ice maker module. Make sure test probes go into test points 1.3 cm (1/2").
2. Test points *T* and *H* will verify the bimetal thermostat is open or closed

Short *T* and *H* with an insulated piece of wire to run motor. If the motor doesn't run, replace module assembly.

If the motor runs, replace the bimetal thermostat.

3. Leave the jumper in for half of a revolution, touch the heater mold. If the mold feels warm, the heater is working properly.

Remove jumper and the water valve will be energized in last half of revolution providing mold heater has not failed.

(Make sure the freezer temperature is cold enough to close the bimetal thermostat.)



CAUTION

Damage to ice maker can result if any other contacts are shorted together other than those specified.

Ice Maker

Shunt Connection

A wire shunt made from an insulated piece of 14-gauge wire with the ends stripped back about 5/8 inch (1.5 cm).

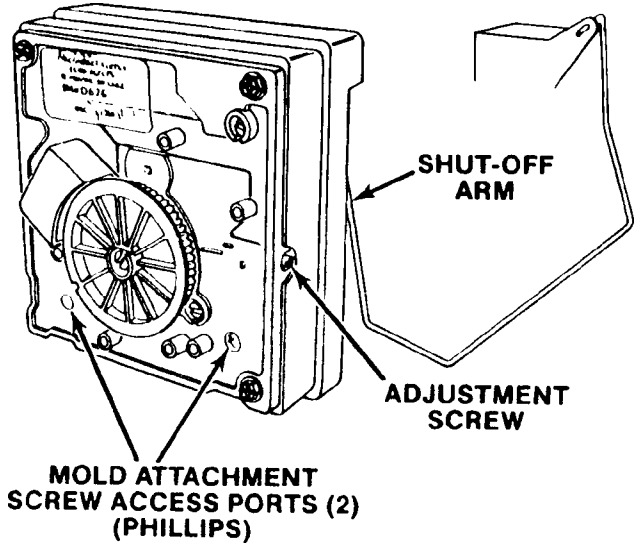
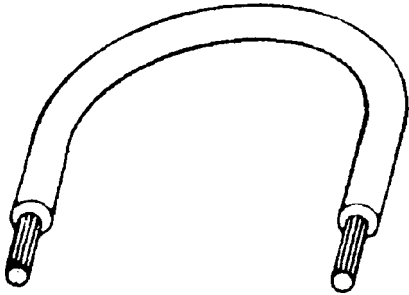

MODULE OHMMETER CHECKS (NO POWER TO ICE MAKER & EJECTOR BLADES IN END OF CYCLE POSITION)			
TEST POINTS	COMPONENT	MODULE POSITION	OHMS
L - H	MOLD HEATER	ATTACHED TO SUPPORT	264
L - M	MOTOR	SEPARATED FROM HEATER	16,100

Module, Motor, and Support Assembly

Insert phillips driver in access ports in module. Loosen both screws. Disconnect shut-off arm. Pull mold from support assembly. To remove module only, remove three phillips screws and pull module out of housing.

MODULE VOLTAGE CHECKS WITH METER OR TEST LIGHT (POWER TO ICE MAKER)			
TEST POINTS	COMPONENT	LINE VOLTAGE	0 VOLTS
L - N	MODULE	POWER OK	NO POWER
T - H	BIMETAL	OPEN	CLOSED
L - H	HEATER	ON	OFF
L - M	MOTOR	ON	OFF
N - V	WATER VALVE	ON	OFF

Shut-Off Arm

Pull out from white bushing. Reinsert to full depth. Follow steps 1, 2, and 3 below.

1. Push arm into center slot in bushing - bottom out.

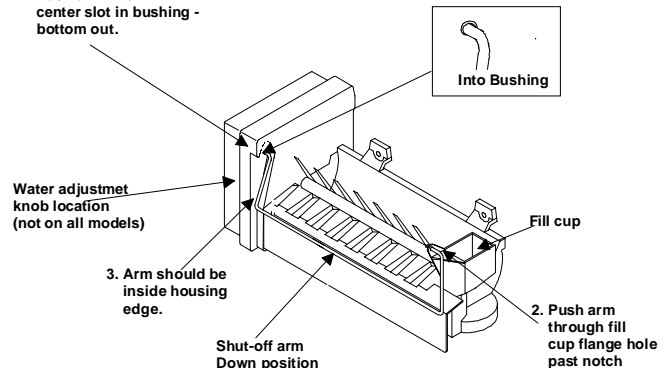

Disassembly Procedures

Cover

Pull water adjustment knob first and snap off cover. Note knob position and reinstall in same position for same water fill.



CAUTION

To avoid possible electrical shock always turn off power before beginning any disassembly.

Module and Heater Assembly

Remove module and support assembly. Install on new mold and heater assembly.

Ice Maker

Fill Cup

Remove module and support assembly. Remove ejector blades and shut-off arm. Pull fill cup from mold.

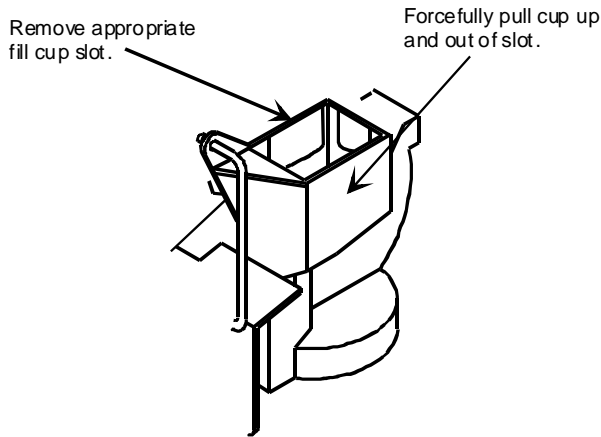



Ejector Blades or Stripper

Remove module and support assembly. When reinstalling ejector blades, realign "D" coupling with module cam.

Accessing Control box

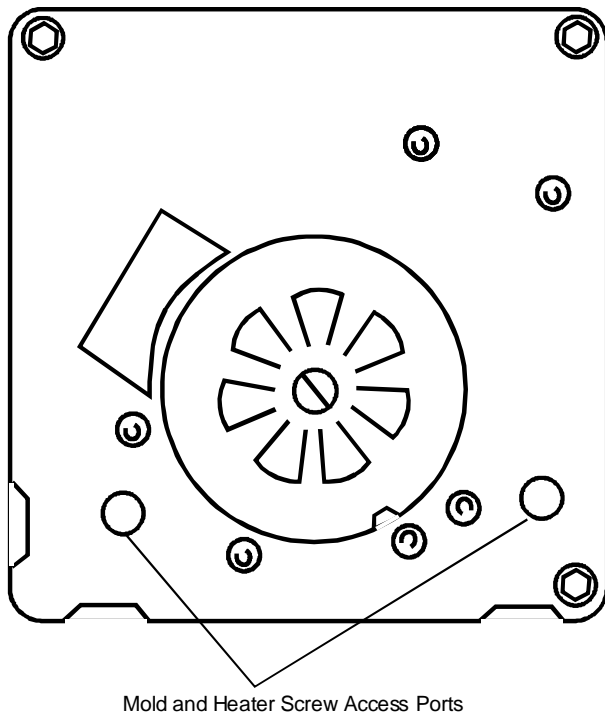
To remove motor and contact assembly from control box, take out three screws (arrows) and pull free after disconnecting shut-off arm.





CAUTION

To avoid damage to main assembly, do not rotate blades or drive gear.

There are several switches which will jam if manually turned counterclockwise and gears will be destroyed if turned clockwise. To advance the ice maker into the cycle, use a jumper to bridge *H* to *R* and unless the motor is defective, it will run. (The shut-off arm must be in the on position.)

NOTE: There are several slotted shafts on the motor assembly board. Do not under any circumstances insert a screwdriver and attempt to turn these shafts. The slots are to permit assembly only.

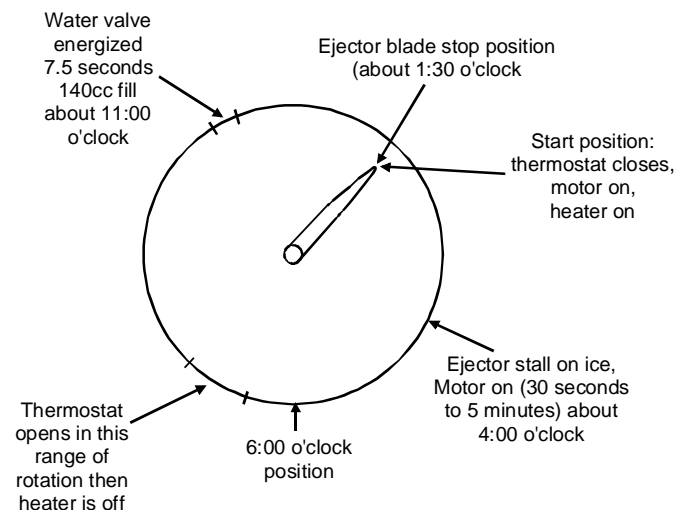
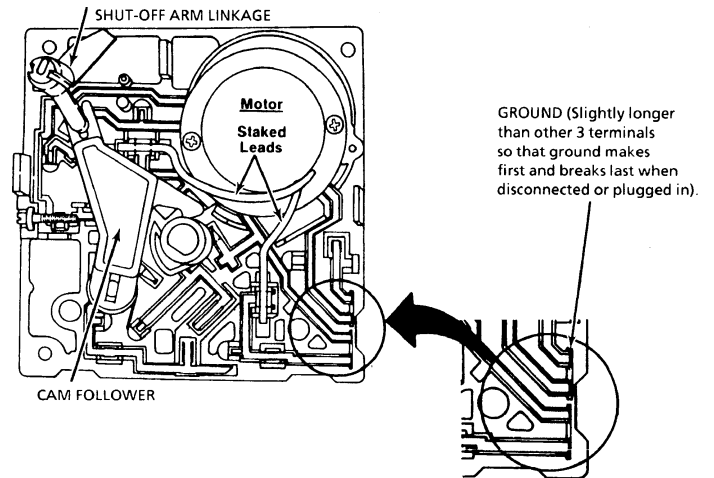
NOTE: There are not repairable or replaceable components in the module. Unless you are replacing the module, there should be no need to remove it when diagnosing or repairing the ice maker.



Ice Maker

Water Fill Adjustment

Turning the water level adjustment screw will move the contact in its relationship with the contact ring segment. This causes the contact to vary time the water valve is energized, since the contact ring is tapered at the end of the fill time.

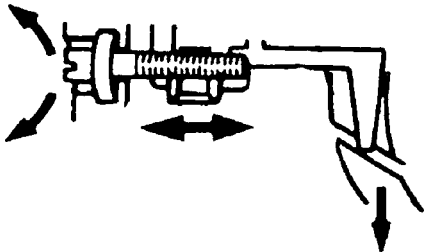

Turning screw clockwise decreases fill; counterclockwise increase fill amount.

1/2 turn equals 20 cc or 1.2 seconds

Full turn equals 40 cc or 2.4 seconds



CAUTION

Maximum adjustment is one full turn either direction. Additional rotation could damage module.

If water valve adjustment screw falls out, just put it back in and align the hole in the hole as shown.

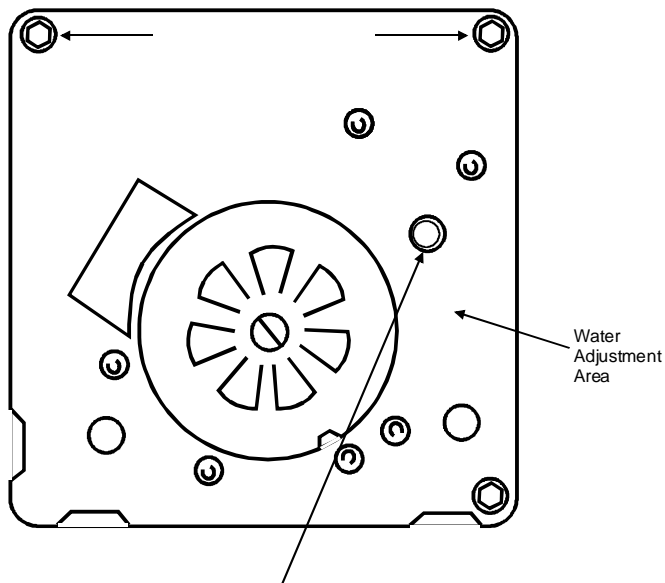

When small hole is centered in larger hole, the water fill adjustment is for 7.5 second fill time (normal).

Water Problems

Water quality can cause ice makers to fail, or produce unacceptable cubes. If mineral content or sand is a problem, the screen in the fill valve can restrict, or a particle of sand can keep the valve from seating properly. Results will be small crescents (or no ice) or flooding of the ice container if the water valve does not

close. Where required, install the ASAP granular activated carbon, odor, tastes, and sediment filter, Part Number R0183114.

Mineral contact can also lime up the mold, causing wicking of water over the mold and poor cube release. Silicone is applied at the upper edges, around fill cup and stripper.

Temperature Problems

Temperatures in freezer section which average above the normal $-18^{\circ}\pm 1^{\circ}\text{C}$ ($0^{\circ}\pm 2^{\circ}\text{F}$) will slow production of ice. Complaints of inadequate ice cube production may be corrected by simply setting the freezer to a colder temperature. The thermostat cycling temperature in the 1-revolution ice maker is $-8^{\circ}\pm 1^{\circ}\text{C}$ ($17^{\circ}\pm 3^{\circ}\text{F}$). Obviously, the ice will be well frozen when these temperatures are achieved but cycling time will be slowed if freezer temperature is not cold enough to achieve these mode temperatures easily.

NOTE: Only the thermostat, mold, with heater and wiring harness, are replaceable. Any other failure (including the motor) requires replacement of the module assembly. The service replaceable mold assembly comes with a new mold heater installed.

External plastic parts are also replaceable.

A failed mold heater requires complete replacement of the mold and mold heater assembly.

Servicing Thermostat

The thermostat can be removed and replaced having been diagnosed as inoperative. Remove control box from mold by taking out two phillips screws.

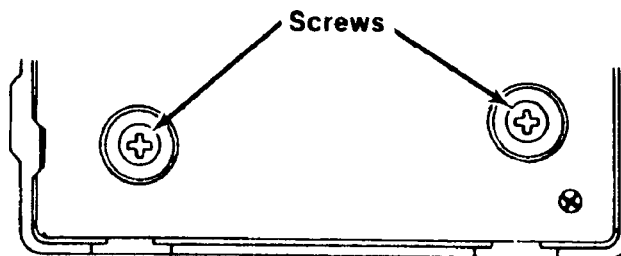

Ice Maker

Pull (front of Black Housing) free of the mold, and see the thermostat on mold side.

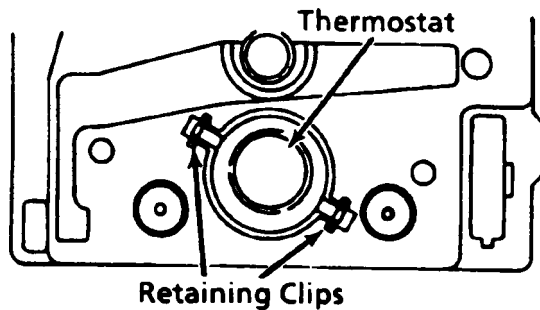

Using needle nose pliers, grasp one of the thermostat clips and pull out. Press in new thermostat, making sure pins are properly indexed. Using this procedure, it is not necessary to remove the electrical assembly.

If replacing the module, transfer the clips to the new mold support. (Use new thermal bonding material.)

Servicing Wire Harness

To remove wiring harness, depress retaining tab and pull plug free.

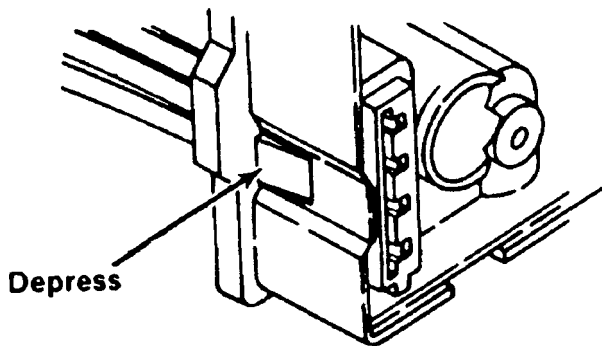

CAUTION

To avoid property damage, always test for water leaks after repair or replacement of the water valve. Do not over tighten connection to household water supply.

Dual Water Valve

The dual water valve has two solenoids. When the tan encapsulated solenoid is energized the amount of water allowed to enter ice maker mold is directly proportional to the length of time the water valve switch is held closed by the timing cam.

Inside the valve is a flow washer which acts as a water pressure regulator. Proper ice maker fill is 140 cc \pm 10 cc at 7.5 seconds of water fill at an inlet pressure ranging from 1.4 to 8.2 bar (20 to 120 PSI).

When the light blue encapsulated solenoid is energized water flows through the coiled water tank to the cavity spickett.

The water flow rate is to be 1.7 to 3.5 liter per minute with 1.4 to 8.2 bar (20 to 120 PSI) pressure drop across valve.

The valve also incorporates a 80 mesh screen water strainer.

Wiring Harness

A one-time thermal fuse micro device 78°C (170° F) is incorporated into the ice maker wiring harness to protect the plastic liner from melting if the ice maker should overheat. The thermal fuse is spliced into the red wire of the ice maker harness. The thermal fuse is a 78° C (170°F) nonresettable fuse. A "No Ice" complaint could be caused by excessive heat. Replacing only the wiring harness will only temporarily solve the problem. The ice maker thermostats should also be replaced

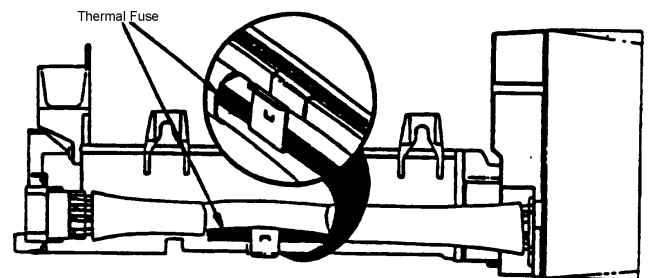

Ice Maker Troubleshooting Chart

I. NO ICE/LOW ICE PRODUCTION	
1. Freezer not cold enough	1. Adjust Freezer or Repair Freezer
2. Broken Locking Tab on Vertical Cam	2. Change Ice Maker Module
3. Module Shut-Off Switch And Contacts Shorted & Burned	3. Change Ice Maker Module
4. Motor Stalled or Stripped	4. Change Ice Maker Module
5. Check Ejector Position	
A. Park (2:30 Ejector Position)	
1 Contaminated Module (No run when jumped through "T" and "H" probe holes)	1. Change Ice Maker Module
2 Open/Missing Thermostat	2. Install or Replace Thermostat (Apply Fresh Alumilastic)
3 No Power To Icemaker (Harness)	3. Trace Power to Determine Discontinuity
4 Jammed Cubes (Notice size of Cube, Hollow?)	4. Unjam Cube, Check Fill Tube & Fill-Cup Assembly
5 Little or No Water to Ice Maker (Note Cube Size)	
a. Frozen Fill Tube (Leaky Water Valve)	a. Change Ice Maker Valve
b. Kinked Water Line	b. Un-Kink Line, Check for Weak Spots
c. Obstructed Water Line to Ice Maker or Refrigerator	c. Water Line Must Be Cleared
d. Clogged Water Valve	d. Change Water Valve
e. No Power to Water Valve	e. Trace Power to Determine Discontinuity
f. Low Water Pressure (NOTE: Jump Cycle through "T" & "H" Probe holes for 10 Sec. , Then Remove Jumpers) Catch Water in Glass	f. Water Pressure Must Be Increased (20 -120 psi) (1.4 - 8.2 bar) Should be About 140 cc's
g. Open Heater Circuit	g. Change Mold and Heater Assembly
h. Closed Thermostat	h. Change Thermostat
i. Damaged Heater Tulips on Module	i. Change Module
j. Heater Pins Too Short - Not Contacting Module	j. Change Mold/Heater Assembly
6 Bail Shut-off Arm In Vacation Mode - No Ice	6. Lower Bail Shut-off Arm To Begin Cycle
7 Bail Shut-off Arm Binds When Raised or Lowered	
a. Water/Ice in Actuator/Housing Hole	a. Remove Module, Dry Actuator and Housing Hole
b. Housing Hole Small or Burred	b. Repair or Replace Ice Maker
c. Actuator O.D. Large or Burred	c. Replace Ice Maker Module
d. Module Housing Damaged	d. Replace Ice Maker Module
e. Bail Shut-off Arm Misformed	e. Replace Bail Shut-off Arm
8 Little/No Alumilastic on Thermostat	8. Apply Fresh Coat of Alumilastic to Thermostat
9 Housing to Mold Screws Not Seated	9. Tighten Two Screws With Phillips Driver (20-26 In.lb) (22.8 - 29.6 cm/kg)
10 Heater Not Staked In Mold	10 Replace Mold/Heater Assembly, Apply fresh Coat of Alumilastic
11 Wrong Heater Temperature	11 Replace Mold/Heater Assembly, Apply fresh Coat of Alumilastic
12 Broken S/O Lever (Mislocated Shut-Off Switch)	12 Replace Ice Maker Module

Ice Maker Troubleshooting Chart

I. NO ICE/LOW ICE PRODUCTION (cont.)	
5. Check Ejector Position (cont)	
B. 3:00 Ejector Position	
1. Contamination	1. Replace Ice Maker Module
2. Cube Jammed (Notice Size of Cube, Hollow?)	2. Un-Jam Cubes
3. Ice Maker or Refrigerator Not Level	3. Level as Needed
4. No Power To Ice Maker	4. Trace Power to Determine Discontinuity
5. Excessive Water-Fill Volume (Large Cubes)	5. Adj. Volume Screw on Module, Change Water Valve or Lower Pressure
6. Rack of Cubes Fell Back Into Mold During Ejection	6. Install New Fill Cup, Check Fill Tube Assy.
C. 4:00 Ejector Position	
1. Contamination	1. Change Ice Maker Module
2. Thermostat out of calibration	2. Change Out Thermostat, Apply Fresh Coat Of Alumilastic
3. Open Heater Circuit (Motor Should be Oscillating)	3. Change Mold/Heater Assy, Apply Fresh Coat Of Alumilastic
4. Little/No Alumilastic on Thermostat	4. Apply Fresh Coat Of Alumilastic
5. Heater Not Staked In Mold	5. Change Mold/Heater Assy, Apply Fresh Coat Of Alumilastic
6. Broken Locking Tabs on Vertical Cam	6. Change Module
D. 6:00 Ejector Position	
1. Contamination	1. Change Ice Maker Module
2. Hollow Cubes	2. Refer to Section III, "Hollow Cubes"
3. Insufficient Water To Ice Maker, Small Cubes	3. Refer to Section III, "Hollow Cubes"
E. 7:30 Ejector Position	
1. Contamination (Motor Will Not Oscillate)	1. Change Ice Maker Module
2. Bail Arm Stuck in Ice or Obstructed	2. Remove Obstruction, Replace Ice Maker Module
3. Pac-Man Cubes (Cubes not formed properly)	3. Un-Jam Unit, Check Fill Cup And Fill Tube Assy.
F. 9:00 Ejector Position	
1. Contamination	5. Change Ice Maker Module
2. Cube Frozen to Fill Cup or Mold	5. Un-Jam Unit, Install New Fill Cup and Module

Ice Maker Troubleshooting Chart

II. OVER PRODUCTION OF ICE	
1. Bail Shut-off Arm Not in Actuator	1. Replace Bail Shut-off Arm in Actuator, Note for Loose Fit
2. Misformed Bail Shut-off Arm	2. Replace Bail Shut-off Arm
3. Shut-Off Lever Broken or Bypassing Vertical Cam	3. Replace Ice Maker Module
4. Broken Module Actuator	4. Replace Ice Maker Module

III. HOLLOW ICE CUBES	
1. Water Fill Volume Too Low	1. Adj. Screw On Module, Clear Water Path Or Change Water Valve
2. Improper Freezer Air-Flow	2. Re-Direct Air Flow Away from Ice Maker Thermostat
3. Thermostat Out Of Calibration	3. Change Thermostat, Apply Fresh Alumilastic

IV. FLOODING OR ICE SLABS IN BUCKET OR FREEZER	
1. Thermostat Out Of Calibration	1. Change Thermostat, Apply Fresh Alumilastic
2. Jammed Cube Stalled In Water-Fill Cycle	2. Remove Cube, Determine Reason For Stall
3. Leaky Water Valve	3. Change Water Valve
4. Fill Volume of Water Valve Excessive	4. Change Water Valve
5. Motor Stalled In Water-Fill Cycle (12:00 Ejector Position)	5. Change Ice Maker Module
6. Contaminated Module	6. Change Ice Maker Module
7. Refrigerator or Ice Maker Not Level	7. Level As Necessary
8. Excessive Water Pressure	8. Lower Water Pressure (20-120 psi) (1.4 - 8.2 bar)
9. Module Shut-Off Switch and Contacts Shorted And Burned	9. Change Ice Maker Module
10. Broken Locking Tab On Vertical Cam (Stalled in Waterfill)	10. Change Ice Maker Module
11. Fill-Tube Not Properly Located In Fill Cup	11. Reposition Fill Tube
12. Fill Cup Water Opening Flashed Over/Plugged	12. Change Fill Cup
13. Cubes Fell Over Back Of Ice Maker, Melting Into Freezer	13. Install New Fill Cup

Ice Maker Wiring Diagram and Parts Layout

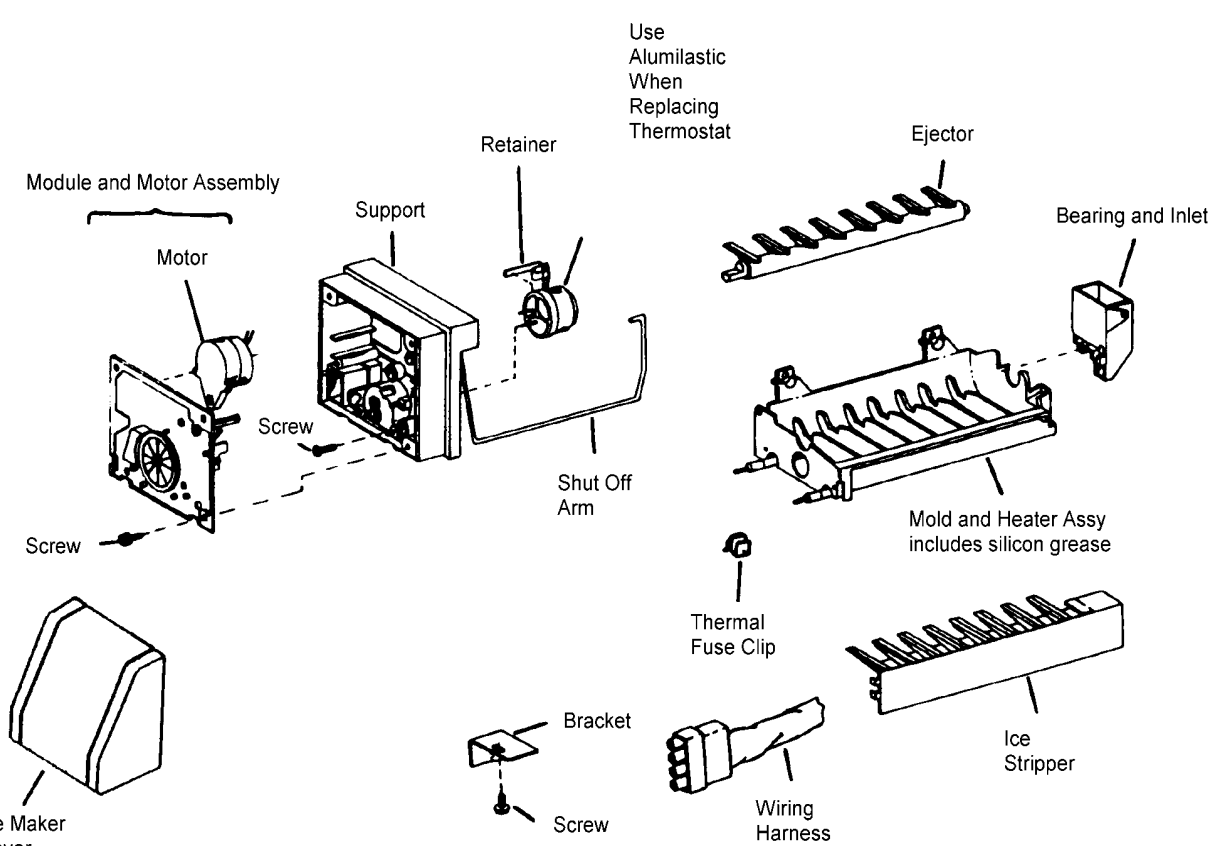
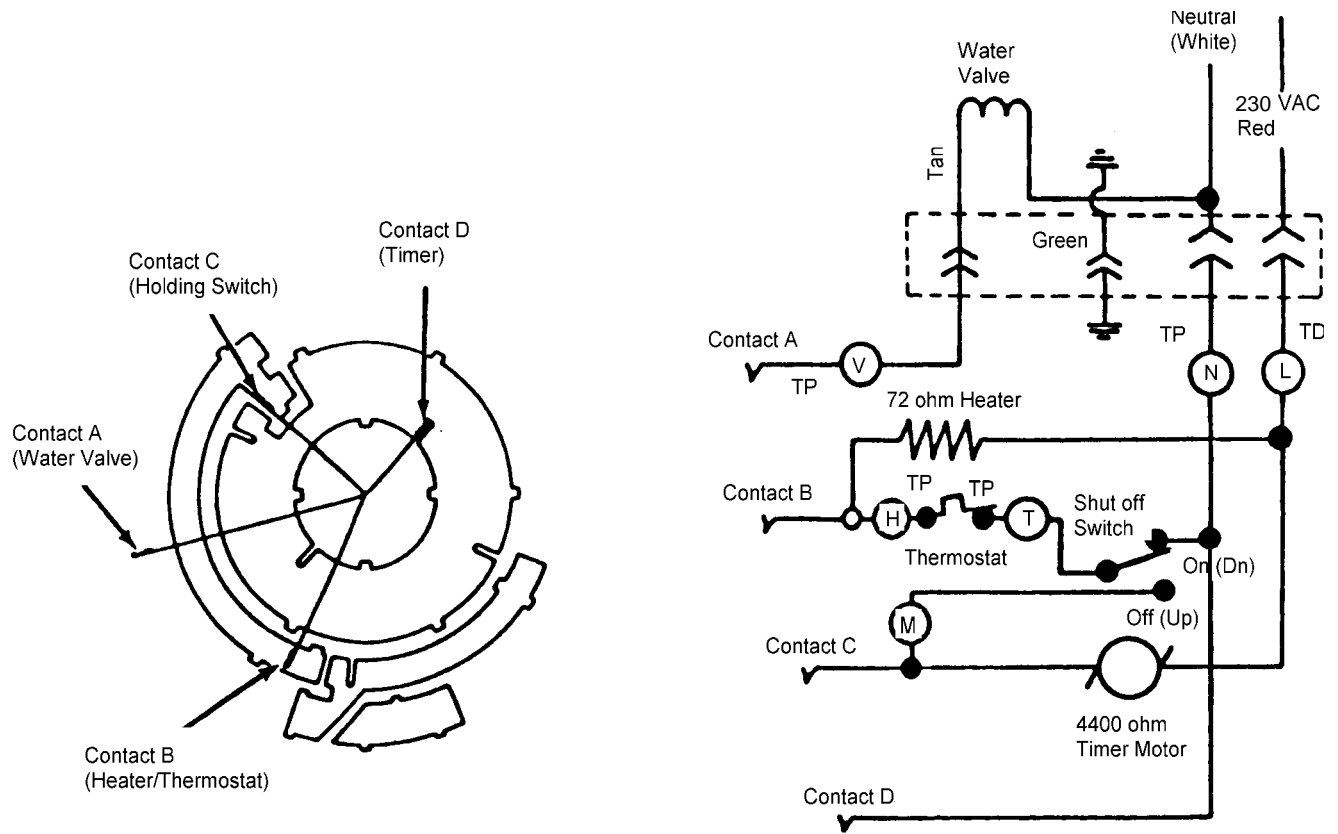

Kit Instructions

HGK300 Black Handle and Toe Grille Kit Installation Instructions

Parts List

Description	Quantity	Part Number	Description	Quantity	Part Number
Toe grille	1	12321806	Bottom trim, refrigerator door	1	10810512
Top trim, freezer door	1	10810311	Door handle	2	12139306
Center trim, freezer door	1	10810603	Black handle insert (top)	2	10953115
Bottom trim, freezer door	1	10810511	Black handle insert (bottom)	2	10953116
Top trim, refrigerator door	1	10810312	Door stop	2	C8972403
Center trim, refrigerator and freezer door	2	10810403	Installation Instructions	1	10035710

Introduction

Read entire manual before installing kit. Confirm all parts listed are included in kit. If parts are missing, contact source from whom kit was purchased.

Important

- Mechanical experience is required to install trim kit.
- If unable to solve a problem during installation, contact source from whom kit was purchased.

Procedure



CAUTION

To avoid property damage, protect soft vinyl or other flooring with cardboard, rugs, or other protective material.



CAUTION

To avoid personal injury, protect hands and arms. Trim pieces may have sharp edges.

Important

Save all screws and reuse in original location.

1. Remove upper and lower handle trim from both doors by grasping trim along inside edge of door and pulling forward. Remove inserts above and below each handle.

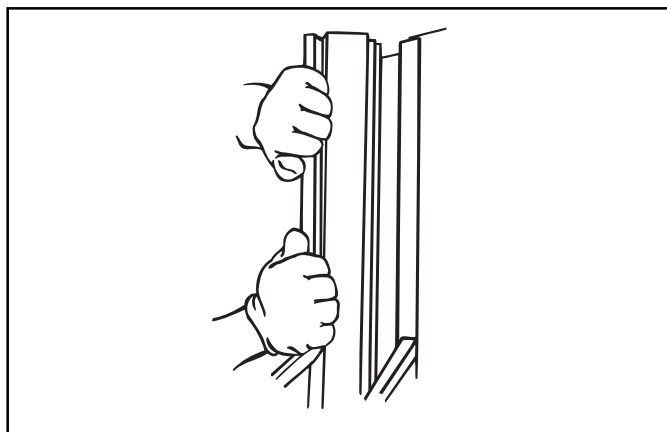

2. Remove door handles by removing screws.

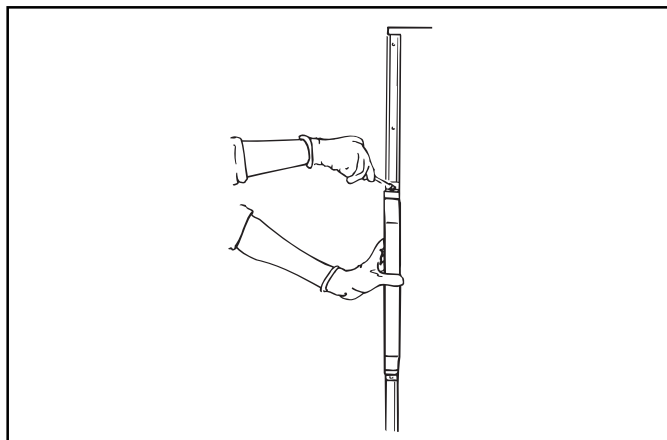

Kit Instructions

3. Dispenser Models

Remove crushed/cubed ice switch cover on dispenser by pulling forward. Remove screws from bottom of dispenser cover. Release bottom clips on dispenser cover by placing taped edge of putty knife underneath cover and pulling out. Release top clips by holding bottom of dispenser cover out and sliding up.

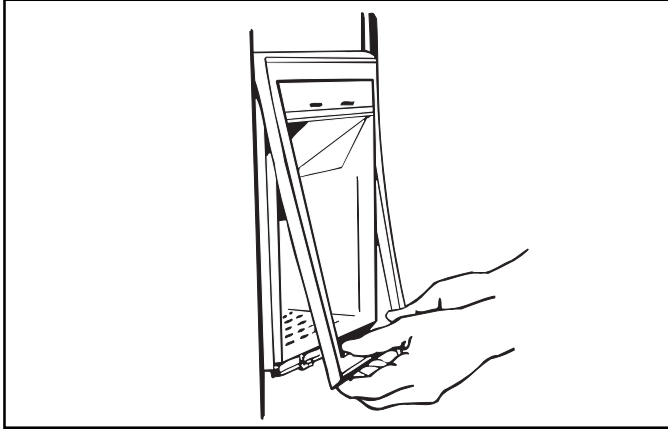

4. Non Dispenser Models

Remove center trim by grasping trim along inside edge of door and pulling forward.

Dispenser Models

Remove center trim on refrigerator door by grasping trim along inside edge of door and pulling forward. Remove center trim on freezer door by removing screws.

5. Non Dispenser Models

Install new black center trim by snapping in place.

Dispenser Models

Install new black center trim on refrigerator door by snapping in place. Install new black center trim on freezer door by placing trim on door. Insert and tighten screws.

Important

One piece of center trim will not be used.

6. Dispenser Models

Replace dispenser cover by snapping in place. Insert and tighten screws. Replace switch by snapping in place.

7. Install new black handles by placing handles on refrigerator. Insert and tighten screws.
8. Place new black inserts above each handle. Install new black trim above each handle by snapping in place. Hold new black inserts below each handle. Install new black trim below each handle by snapping in place.
9. Remove toe grille by pulling forward. Install new black toe grille by inserting clips in holes and snapping in.
10. Remove door stops by removing screws. Install new black door stops by placing door stops on doors. Insert and tighten screws.

Kit Instructions

DS18 and DS22 1/4" Trim Kits

Introduction

Included in this kit are trim pieces for installing 1/4 inch (6 millimeter) decorator panels. Read entire manual before installing panels. Confirm all parts listed are included in kit. If parts are missing, contact source from whom kit was purchased.

Important

- Mechanical experience is required to install trim kit.
- Depending on installer's knowledge and skill, installation can take from one to three hours.
- Transfer food to an alternate cooling source. Check refrigerator warranty certificate for specific coverage. **Warranty does not cover food loss.**
- Ensure trim pieces adhere properly by confirming surfaces are clean, dry and free of adhesive residue.
- If unable to solve a problem during installation, contact source from whom kit was purchased.

Decorator Panel Dimensions

Listed below are required height x width dimensions for decorator panels. Panels are not supplied with this kit and can be purchased locally.



Caution

To avoid personal injury or property damage, refrigerator panels should not weigh more than 30 pounds (14 kilograms) and freezer panels should not weigh more than 15 pounds (7 kilograms).

19 cubic foot Panel Dimensions

Without Dispenser

Refrigerator Door	61 15/16" x 15 13/32" (1573 mm x 391 mm)
Freezer Door	61 15/16" x 13 1/2" (1573 mm x 343 mm)

With Dispenser

Refrigerator Door	61 15/16" x 15 13/32" (1573 mm x 391 mm)
Upper Freezer Door	17 1/4" x 13 1/2" (438 mm x 343 mm)
Lower Freezer Door	31 13/16" x 13 1/2" (808 mm x 343 mm)

20, 22, 25 cubic foot Panel Dimensions

Without Dispenser

Refrigerator Door	61 15/16" x 19 5/32" (1573 mm x 487 mm)
Freezer Door	61 15/16" x 13 1/2" (1573 mm x 343 mm)

With Dispenser

Refrigerator Door	61 15/16" x 19 5/32" (1573 mm x 487 mm)
Upper Freezer Door	17 1/4" x 13 1/2" (438 mm x 343 mm)
Lower Freezer Door	31 13/16" x 13 1/2" (808 mm x 343 mm)

Kit Instructions

Parts List

Item	Description	Qty	Length	DS18E Black	DS18L Almond	DS18S Satin	DS18W White	DS22E Black	DS22S Satin
1	Side Trim, Refrigerator and Freezer Door	2		X	X	X	X	X	X
2	Bottom Trim, Refrigerator Door	1		X	X	X	X	X	X
3	Bottom Trim, Freezer Door	1		X	X	X	X	X	X
4	Top Trim, Refrigerator Door	1		X	X	X	X	X	X
5	Top Trim, Freezer Door	1		X	X	X	X	X	X
6	Top Trim, Dispenser	1	13 7/8"	X	X	X	X	X	X
7	Bottom Trim, Dispenser	1	13 9/16"	X	X	X	X	X	X
8	Panel Trim, Refrigerator and Freezer Door	2	61 29/32"	X	X	X	X	X	X
9	Panel Trim, Lower Ice and Water Freezer Door	1	32 1/8"	X	X	X	X	X	X
10	Panel Trim, Upper Ice and Water Freezer Door	1	17 7/32"	X	X	X	X	X	X
11	Screw, Bottom Trim	5		X	X	X	X	X	X
12	Spacer, Refrigerator Door Bottom Trim	1		X	X	X	X	X	X
13	Spacer, Freezer Door Bottom Trim	1		X	X	X	X	X	X
14	Installation Instructions	1		X	X	X	X	X	X

Kit Instructions

Procedure



Caution

To avoid personal injury or property damage, two people should remove and rehang each door.



Caution

To avoid personal injury or property damage, temporarily tape doors shut.

Important

Save all screws and reuse in original location.

1. Tape doors shut using masking tape.



WARNING

To avoid electrical shock which can cause severe personal injury or death, green ground wire must remain attached to hinge.

2. Remove top hinge covers by removing screws. Trace around top hinges with a pencil. This helps alignment when reassembling. On dispenser models, unplug top hinge wire connectors. Remove top hinge screws.

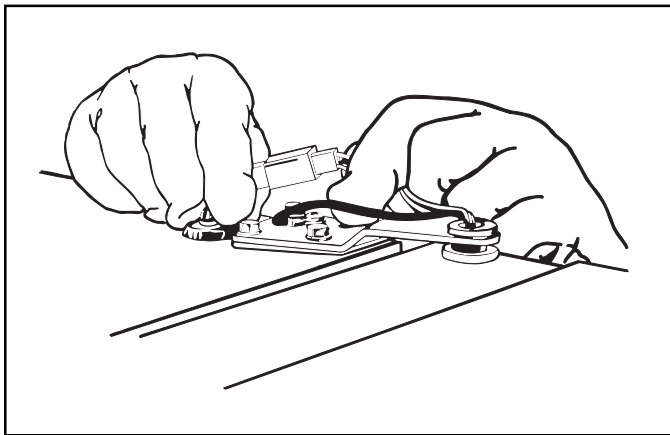

3. Remove tape from refrigerator door. Grasp refrigerator door securely and lift up while opening. This will free door from bottom hinge pin. Top hinge may come off door.
4. Remove toe grille by pulling forward.



Caution

To avoid property damage, drain water from water tube into small bucket.

5. Dispenser Models

Loosen water tube clamp screw. Loosen plastic water tube union nut. Gently pull water tube away from union nut and through tube clamp.

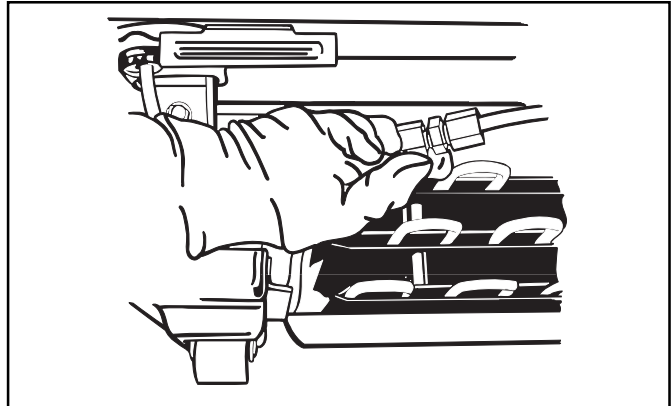

6. Remove tape from freezer door. Grasp freezer door securely and lift up while opening. This will free door from bottom hinge pin. On dispenser models, plastic water tube must slide through slot in bottom door hinge as door is raised.
7. Remove door stops by removing screws. Install spacer and bottom trim by placing spacer and trim on bottom of doors. Insert and tighten bottom trim screws (Item #11). Replace door stops by placing door stops on bottom of doors. Insert and tighten screws.

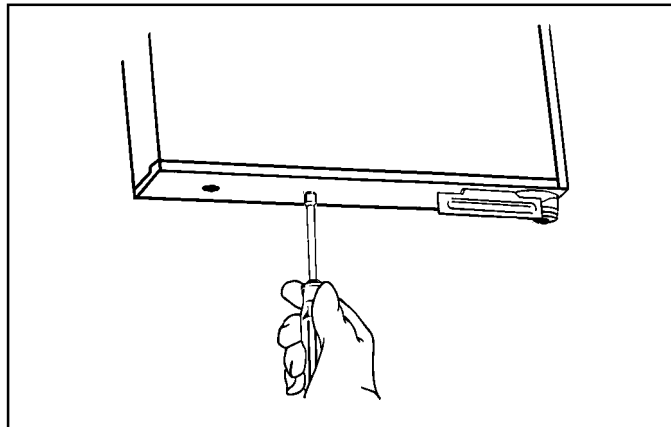

8. Rehang doors by positioning bottom sockets onto bottom door hinge pins. Position so doors are flush with side of refrigerator cabinet. Handle side of doors should be approximately 1/8 inch (3.2 millimeters) higher than hinge side of doors. Doors will settle when loaded with food. On dispenser models, when replacing freezer door, thread water tube through hinge pin then water tube clamp.

Kit Instructions



Caution

To avoid personal injury or property damage, temporarily tape doors shut.

9. Tape doors shut using masking tape.
10. Replace top hinges by placing top hinges on refrigerator. Insert and tighten screws. On dispenser models, reconnect top hinge wire connectors by snapping together. Replace top hinge covers by placing hinge covers over hinges. On dispenser models, carefully place wires under cover to avoid pinching wires. Insert and tighten screws.



WARNING

To avoid electrical shock which can cause severe personal injury or death, green ground wire must be attached to freezer door hinge.

Important

Permanent, double-sided tape is used to attach some trim pieces to refrigerator. Before removing paper backing, check placement of trim pieces on refrigerator. Trim pieces may be damaged if adjustment or removal is attempted after installation.

11. Install top door trim. There may be some interference between top trim and top handle trim. If there is interference, complete the following steps:
 - Remove upper and lower handle trim from both doors by grasping trim along inside edge of trim and pulling forward.
 - Remove inserts above and below each handle.

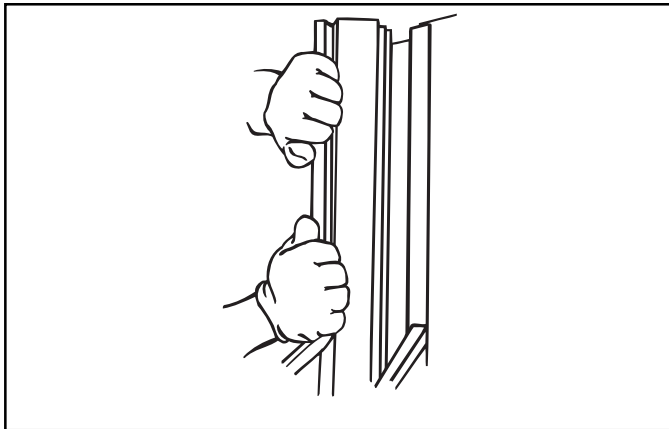

Discard inserts.

- Replace upper and lower handle trim by snapping in place. Confirm trim is flush with handle.

Peel off 1 1/2 inches (38 millimeters) of backing. Place trim firmly against inside of door and against back of door. After checking placement, peel off backing and press into place.

12. Non Dispenser Models

Remove nameplate by placing putty knife covered with masking tape under nameplate and pulling forward. Discard nameplate.

Important

Confirm front surface of decorator door panels and trim are facing forward when installing trim.

Refrigerator Door

13. Install panel trim (Item #8) by placing trim at an angle on left edge of refrigerator door panel. Press trim onto panel. Center trim on side of panel.

Freezer Door -- Non Dispenser Models

14. Install panel trim (Item #8) by placing trim at an angle on right edge of freezer door panel. Press trim onto panel. Center trim on side of panel.

Freezer Door -- Dispenser Models

15. Install top dispenser trim (Item #6) by placing trim at an angle on bottom edge of upper freezer panel. Press trim onto panel. Install upper ice and water freezer door panel trim (Item #10) by placing trim on right edge of upper freezer panel. Press trim onto panel. Trim pieces must overlap at the corner.
16. Install bottom dispenser trim (Item #7) by placing trim at an angle on top edge of lower freezer panel. Press trim onto panel. Install lower ice and water freezer door panel trim (Item #9) by placing trim on right edge of lower freezer panel. Press trim onto panel. Trim pieces must overlap at the corner.



Caution

To prevent property damage, place masking tape on back of panel at each corner. Tape prevents panel from damaging doors.

17. Place masking tape on back of panels at each corner.
18. Slide decorator door panels into place under handle trim until panels are secure.

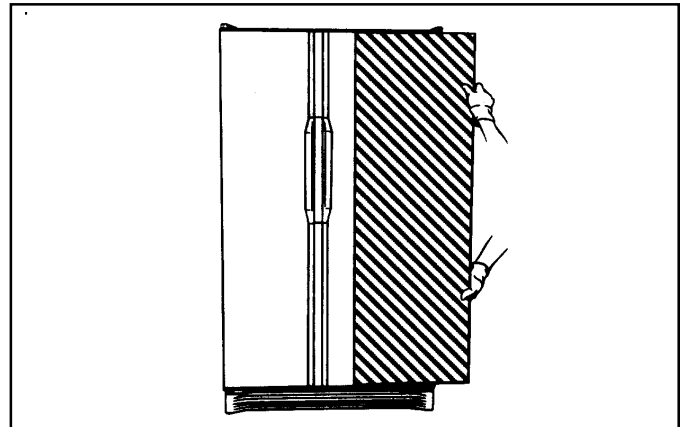

Kit Instructions

19. Install side door trim by peeling off 1 1/2 inches (38 millimeters) of backing. Place trim against top corner of refrigerator cabinet over edge of top trim. After checking placement, peel off backing and press into place. Place side door trim over edge of bottom trim.

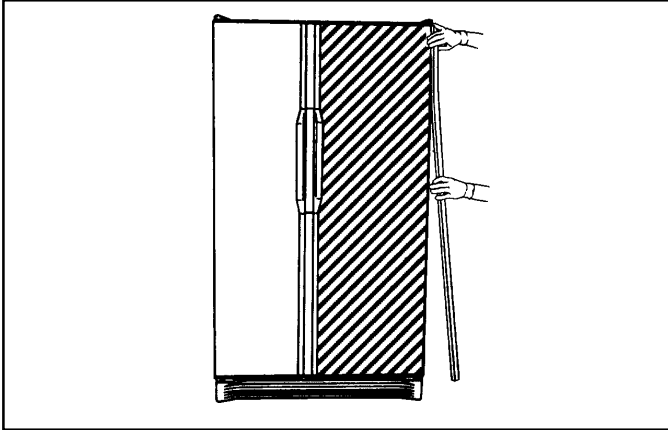

20. Push water tube into plastic union nut and tighten union nut by hand. Gently pull on tube to confirm nut is tight. Tighten water tube clamp screw.



Caution

To avoid property damage, confirm water tube union nut is secure and check for leaks before replacing toe grille.

21. Replace toe grille by inserting clips in holes and snapping in.

Kit Instructions

DS19, DS20 and DS21 1/16" Trim Kits with 1/4" Retainers

Introduction

Important

- Mechanical experience is required to install trim kit.
- Depending on installer's knowledge and skill, installation can take from one to three hours.
- Transfer food to an alternate cooling source. Check refrigerator warranty certificate for specific coverage. **Warranty does not cover food loss.**
- Ensure trim pieces adhere properly by confirming surfaces are clean, dry and free of adhesive residue.
- If unable to solve a problem during installation, contact source from whom kit was purchased.

Decorator Panel Dimensions

Listed below are required height x width dimensions for decorator panels. Panels are not supplied with this kit and can be purchased locally.



Caution

To avoid personal injury or property damage, refrigerator panels should not weigh more than 30 pounds (14 kilograms) and freezer panels should not weigh more than 15 pounds (7 kilograms).

21 cubic foot 1/16" (2 mm)

Panel Dimensions

Without Dispenser

Refrigerator Door	61 7/8" x 15 13/16" (1572 mm x 402 mm)
Freezer Door	61 7/8" x 13 15/16" (1572 mm x 354 mm)

With Dispenser

Refrigerator Door	61 7/8" x 15 13/16" (1572 mm x 402 mm)
Upper Freezer Door	17 9/16" x 13 15/16" (446 mm x 354 mm)
Lower Freezer Door	32 3/16" x 13 15/16" (818 mm x 354 mm)

21 cubic foot 1/4" (6 mm)

Panel Dimensions

Without Dispenser

Refrigerator Door	61 1/4" x 15 3/16" (1556 mm x 386 mm)
Freezer Door	61 1/4" x 13 5/16" (1556 mm x 338 mm)

With Dispenser

Refrigerator Door	61 1/4" x 15 3/16" (1556 mm x 386 mm)
Upper Freezer Door	16 7/8" x 13 5/16" (429 mm x 338 mm)
Lower Freezer Door	31 3/8" x 13 5/16" (797 mm x 338 mm)

27 cubic foot 1/16" (2 mm)

Panel Dimensions

Non Electronic

Refrigerator Door	61 7/8" x 19 9/16" (1572 mm x 497 mm)
Upper Freezer Door	17 9/16" x 13 15/16" (446 mm x 354 mm)
Lower Freezer Door	32 3/16" x 13 15/16" (818 mm x 354 mm)

Electronic

Refrigerator Door	61 7/8" x 17 3/4" (1572 mm x 451 mm)
Upper Freezer Door	17 9/16" x 13 15/16" (446 mm x 354 mm)
Lower Freezer Door	32 3/16" x 13 15/16" (818 mm x 354 mm)

27 cubic foot 1/4" (6 mm)

Panel Dimensions

Non Electronic

Refrigerator Door	61 1/4" x 18 15/16" (1556 mm x 481 mm)
Upper Freezer Door	16 7/8" x 13 5/16" (429 mm x 338 mm)
Lower Freezer Door	31 3/8" x 13 5/16" (797 mm x 338 mm)

Electronic

Refrigerator Door	61 1/4" x 17 3/8" (1556 mm x 441 mm)
Upper Freezer Door	16 7/8" x 13 9/16" (429 mm x 344 mm)
Lower Freezer Door	31 3/8" x 13 9/16" (797 mm x 344 mm)

Kit Instructions

Parts List

Description	Qty	Length	DS19E Black	DS19S Stainless	DS20E Black	DS20S Stainless	DS21S Stainless
Trim, Refrigerator and Freezer Door Sides	2		X	X	X	X	X
Trim, Refrigerator Door Bottom	1		X	X	X	X	X
Trim, Freezer Door Bottom	1		X	X	X	X	X
Trim, Refrigerator Door Top	1		X	X	X	X	X
Trim, Freezer Door Top	1		X	X	X	X	X
Retainer, Freezer Door Top and Bottom	4	13 5/16"	X	X			X
Retainer, Freezer Door Top	2	13 27/32"			X	X	
Retainer, Freezer Door Bottom	2	13 17/32"			X	X	
Retainer, Refrigerator Door Top and Bottom	2	19 9/32"	X	X			
Retainer, Refrigerator Door Top and Bottom	2	15 17/32"					X
Retainer, Refrigerator Door Top	1	17 5/16"			X	X	
Retainer, Refrigerator Door Bottom	1	17 21/32"			X	X	
Retainer, Upper Freezer Door Sides	2	17 7/32"	X	X			X
Retainer, Upper Freezer Door Side	1	17 7/32"			X	X	
Retainer, Lower Freezer Door Sides	2	31 3/4"	X	X			X
Retainer, Lower Freezer Door Side	1	31 3/4"			X	X	
Retainer, Refrigerator Door Sides	2	61 7/32"	X	X			
Retainer, Refrigerator and Freezer Door Sides	4	61 7/32"					X
Retainer, Refrigerator Door Side	1	61 7/32"			X	X	
Insert, Refrigerator Door Handle	1				X	X	
Insert, Freezer Door Handle	1				X	X	
Screw, Bottom Trim	6		X	X	X	X	X
Spacer, Trim	3		X	X	X	X	X
Installation Instructions	1		X	X	X	X	X

Kit Instructions

Procedure

Extruded Handle Models



Caution

To avoid personal injury, protect hands and arms. Trim pieces may have sharp edges.

Important

Save all screws and reuse in original location.

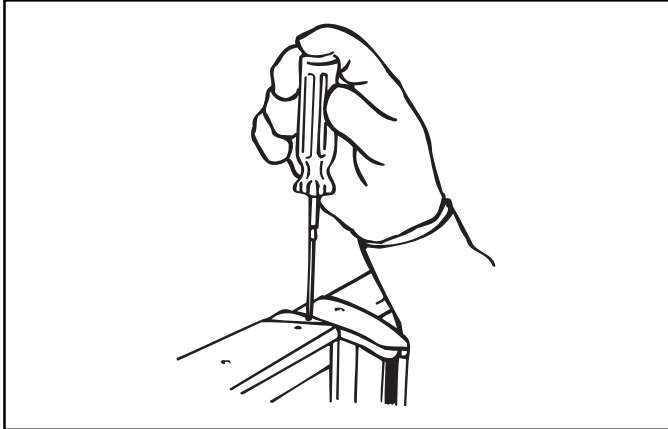

1. Remove top handle end caps by removing screws.

Important

If installing 1/16 inch (2 millimeter) panels, proceed to step 6. If installing 1/4 inch (6 millimeter) panels, proceed with step 2.

2. Remove crushed/cubed ice switch cover on dispenser by pulling forward. Remove screws from bottom of dispenser cover. Release bottom clips on dispenser cover by placing taped edge of putty knife underneath cover and pulling out. Release top clips by holding bottom of dispenser cover out and sliding up.

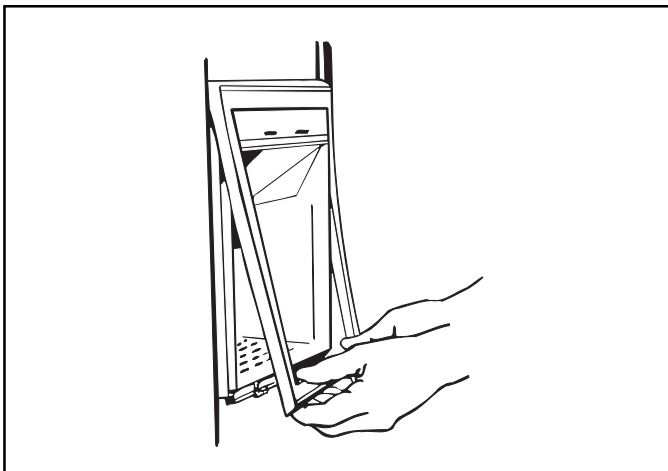

3. Remove door handle inserts by placing screwdriver at top of door handles in area between handle and insert and pulling out.

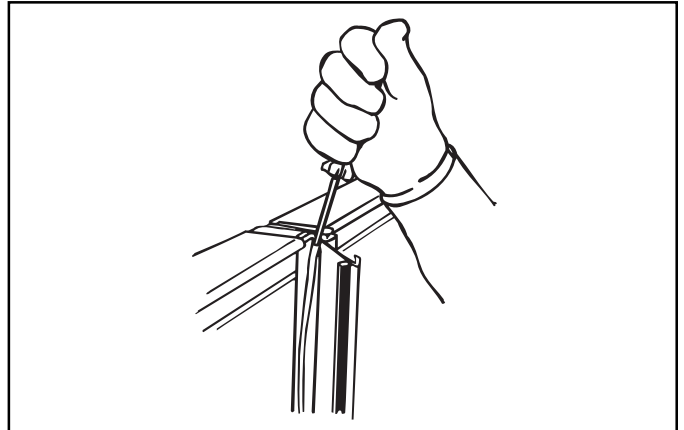

4. Pull inserts out along length of handles.

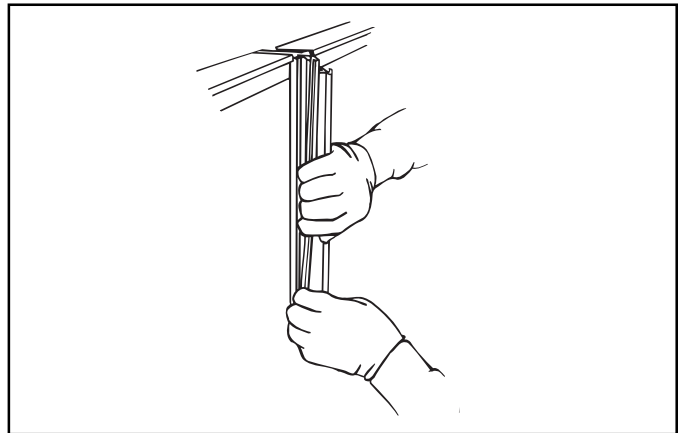

5. Install new handle inserts by reversing steps 3-4.
6. Replace dispenser cover by snapping in place. Insert and tighten screws. Replace switch by snapping in place.
7. Remove thin section on top handle end caps to allow room for panels. Discard section. Replace top handle end caps by placing end caps on handles. Insert and tighten screws.

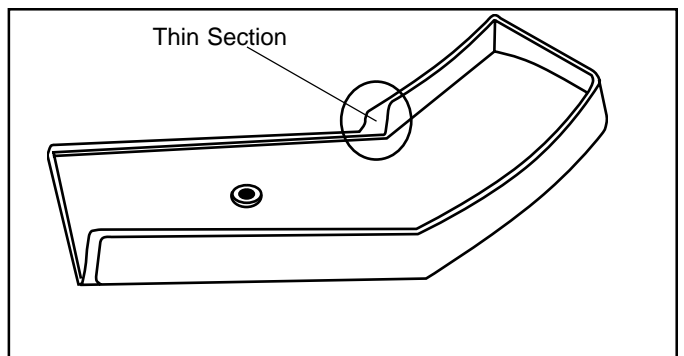

Kit Instructions

All Models

Important

Use cardboard spacers carefully. Spacers must be reused to provide correct clearance at top and bottom edges of each door.

- Use masking tape to place two cardboard spacers on front surface of doors flush with top edge. Place spacers approximately 2 inches (51 millimeters) in from handle side of door and 2 inches (51 millimeters) from hinge side of door.

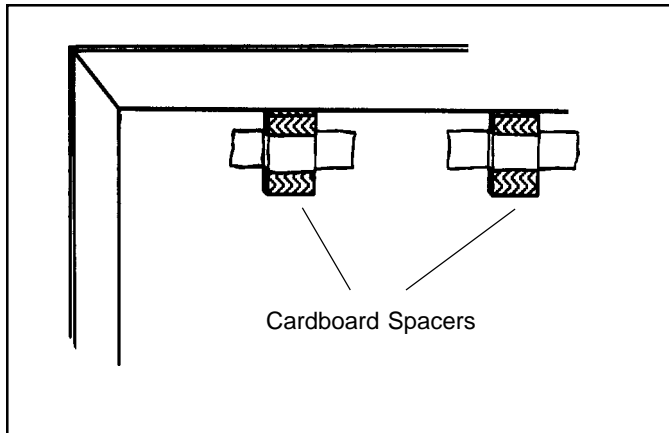

Important

- Rounded edge of trim must be installed toward front of door. Channel holds and frames 1/16 inch (2 millimeter) panels or 1/4 inch (6 millimeter) retainers.

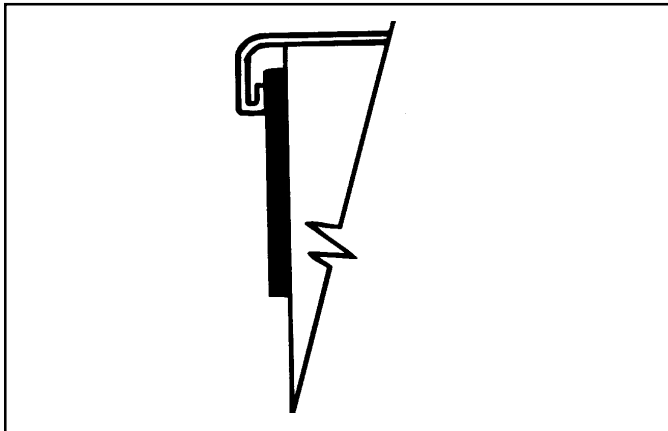

- Permanent, double-sided tape is used to attach some trim pieces to refrigerator. Before removing paper backing, check placement of trim pieces on refrigerator. Trim pieces may be damaged if adjustment or removal is attempted after installation.
- Top trim covers only section of top door surface in front of hinge.

- On extruded handle models, check top trim fit by aligning end of top trim against handle cap. On non extruded handle models, check top trim fit by aligning end of trim with handle-side edge of door.
- Install top door trim. There may be some interference between top trim and top handle trim. If there is interference, complete the following steps:
 - Remove upper and lower handle trim from both doors by grasping trim along inside edge of trim and pulling forward.

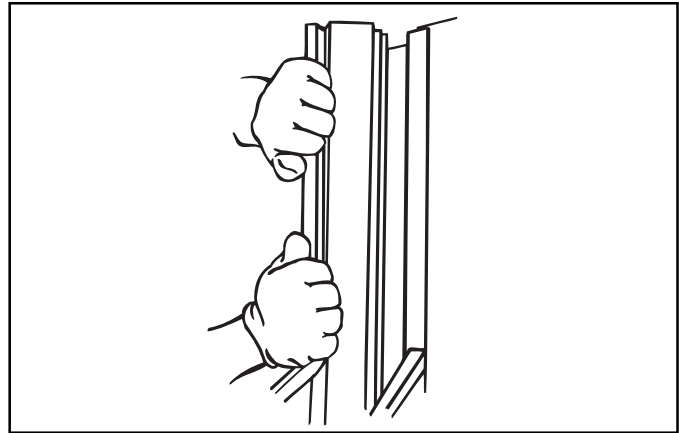

- Remove inserts above and below each handle. Discard inserts.
- Replace upper and lower handle trim by snapping in place. Confirm trim is flush with handle.

Peel off 1 1/2 inches (38 millimeters) of backing. Place trim firmly against inside of door and against back of door. After checking placement, peel off backing and press into place.

- Remove cardboard spacers and replace spacers on front surface of doors flush with bottom edge. Place spacers approximately 2 inches (51 millimeters) in from handle side of door and 2 inches (51 millimeters) from hinge side of door.

Important

Bottom trim covers only section of bottom door surface in front of hinge. Do not overtighten screws.

- Check bottom trim fit by aligning trim with holes in bottom of door and against handle. Insert screws and tighten.
- Remove cardboard spacers from doors.
- On non dispenser models, remove nameplate by placing putty knife covered with masking tape under nameplate and pulling forward. Discard nameplate.

Important

If installing 1/16 inch (2 millimeter) panels, refer to "1/16 inch (2 millimeter) Panels" section. If installing 1/4 inch (6 millimeter) panels, refer to "1/4 inch (6 millimeter) Panels" section.

Kit Instructions

DS21S Kit - Non Dispenser Models

Install 1/4 inch (6 millimeter) freezer door top retainer (Item #6) by placing trim at an angle on top edge of panel. Align straight end of trim flush with panel corner. Press trim onto panel. Install freezer door side retainer (Item #17), freezer door bottom retainer (Item #6) then freezer door side retainer (Item #17) on panel. Notched end of trim must overlap straight end of previously installed trim. Confirm trim is secure. Remove nameplate by placing putty knife covered with masking tape under nameplate and pulling forward. Discard nameplate.

DS21S Kit - Dispenser Models

Install 1/4 inch (6 millimeter) upper and lower freezer door top retainers (Item #6) by placing trim at an angle on top edge of panel. Align straight end of trim flush with panel corner. Press trim onto panel. Install upper and lower freezer door right side retainers (Items #12 or #14, respectively), upper and lower freezer door bottom retainers (Item #6) then upper and lower freezer door left side retainers (Items #12 or #14, respectively) on panel. Notched end of trim must overlap straight end of previously installed trim. Confirm trim is secure.

All Models



Caution

To prevent property damage, place masking tape on back of panel at each corner. Tape prevents panel from damaging doors.

1. Place masking tape on back of panels at each corner.
2. Slide decorator door panels into place until panels are secure. On DS19 and DS21 kits, handle side of panel trim slides under handle trim. On DS20 and DS20 kits, handle side of panel slides under handle insert.

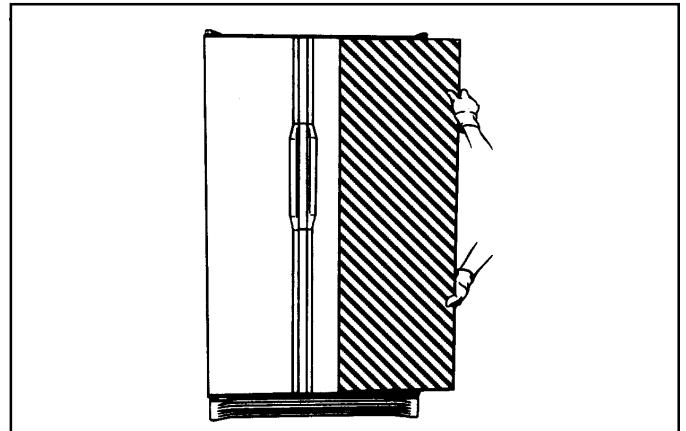

3. Install side door trim by peeling off 1 1/2 inches (38 millimeters) of backing. Place trim against top corner of refrigerator cabinet over edge of top trim. After checking placement, peel off backing and press into place. Place side door trim over edge of bottom trim.

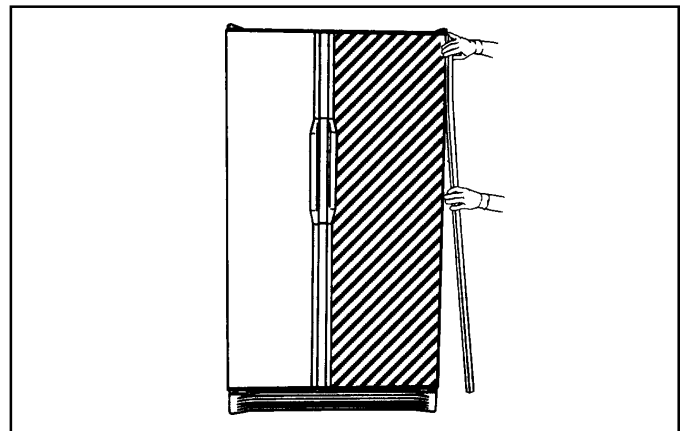

Kit Instructions

DS23, DS24, DS25, and DS26 1/4" Trim Kits

Introduction

Important

- Mechanical experience is required to install trim kit.
- Depending on installer's knowledge and skill, installation can take from one to three hours.
- Transfer food to an alternate cooling source. Check refrigerator warranty certificate for specific coverage. **Warranty does not cover food loss.**
- Ensure trim pieces adhere properly by confirming surfaces are clean, dry and free of adhesive residue.
- If unable to solve a problem during installation, contact source from whom kit was purchased.

Decorator Panel Dimensions

Listed below are required height x width dimensions for decorator panels. Panels are not supplied with this kit and can be purchased locally.



Caution

To avoid personal injury or property damage, refrigerator panels should not weigh more than 30 pounds (14 kilograms) and freezer panels should not weigh more than 15 pounds (7 kilograms).

Without Dispenser

Refrigerator Door	61 15/16" x 19 3/8" (1573 mm x 492 mm)
Freezer Door	61 15/16" x 13 3/4" (1573 mm x 349 mm)

With Dispenser

Refrigerator Door	61 15/16" x 19 3/8" (1573 mm x 492 mm)
Upper Freezer Door	17 1/4" x 13 3/4" (438 mm x 349 mm)
Lower Freezer Door	31 13/16" x 13 3/4" (808 mm x 349 mm)

Electronic

Refrigerator Door	61 15/16" x 17 5/8" (1573 mm x 448 mm)
Upper Freezer Door	17 1/4" x 13 3/4" (438 mm x 349 mm)
Lower Freezer Door	31 13/16" x 13 3/4" (808 mm x 349 mm)

Kit Instructions

Parts List

Description Quantity	DS23E Black	DS23L Almond	DS23S Satin	DS23W White	DS24E Black	DS24S Satin	DS24W White
Refrigerator, Freezer door side trim, 2	10494518	10494519	10494513	10494517	10494518	10494513	10494517
Refrigerator door bottom trim, 1	10602605	10602608	10602609	10602607	10602605	10602609	10602607
Freezer door bottom trim,1	10602505	10602507	10602508	10602506	10602505	10602508	10602506
Refrigerator door top trim, 1	10765207	10765205	10765209	10765203	10765212	10765213	10765211
Freezer door top trim 1,	10765208	10765206	10765210	10765204	10765208	10765210	10765204
Dispenser trim, 2	B8391242	B8391243	B8391240	B8391241	B8391242	B8391240	B8391241
Door handle insert DS24,26 1 DS23,25 2	10945907	10945906	10945908	10945905	10945907	10945908	10945905
Ice and Water Door handle insert, 1	10945931	10945932	10945929	10945930	10945931	10945929	10945930
Bottom trim screw, 5	M021101 8	M021101 8	M021101 8	M021101 8	M021101 8	M021101 8	M021101 8
Refrigerator door bottom trim spacer, 1	10494603	10494603	10494603	10494603	10494603	10494603	10494603
Freezer door bottom trim spacer, 1	10494604	10494604	10494604	10494604	10494604	10494604	10494604
Installation instructions, 1							

Description Quantity	DS25S Stainless Steel	DS26S Stainless Steel
Refrigerator, freezer door side trim, 2	10494522	10494522
Refrigerator door bottom trim, 1	10602603	10602603
Freezer door bottom trim, 1	10602503	10602503
Refrigerator door Top trim, 1	10765216	10765215
Freezer door top trim, 1	10765214	10765214
Dispenser trim, 2	B8391218	B8391218
Door handle insert DS25, 2 DS26, 1	10945908	10945908
Ice and water door handle insert, 1	10945929	10945929
Bottom trim screw, 5	M0211018	M0211018
Refrigerator door bottom trim spacer, 1	10494603	10494603
Freezer door bottom trim spacer, 1	10494604	10494604
Installation Instructions		

Kit Instructions

Procedure



Caution

To avoid personal injury or property damage, two people should remove and rehang each door.



Caution

To avoid personal injury, protect hands and arms. Trim pieces may have sharp edges.

Important

Save all screws and reuse in original location.

1. Remove top handle end caps by removing screws.

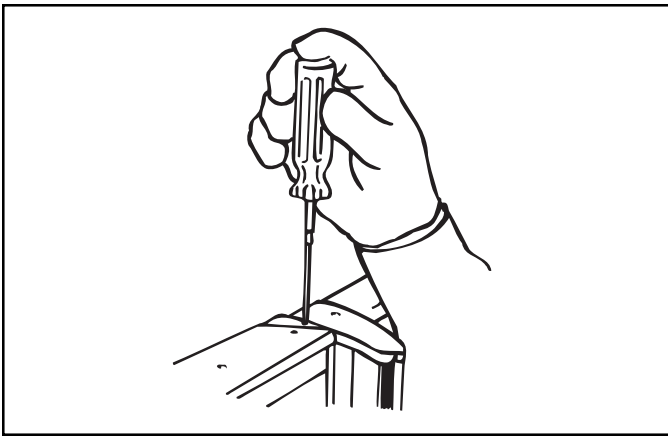

2. Dispenser Models

Remove crushed/cubed ice switch cover on dispenser by pulling forward. Remove screws from bottom of dispenser cover. Release bottom clips on dispenser cover by placing taped edge of putty knife underneath cover and pulling out. Release top clips by holding bottom of dispenser cover out and sliding up.

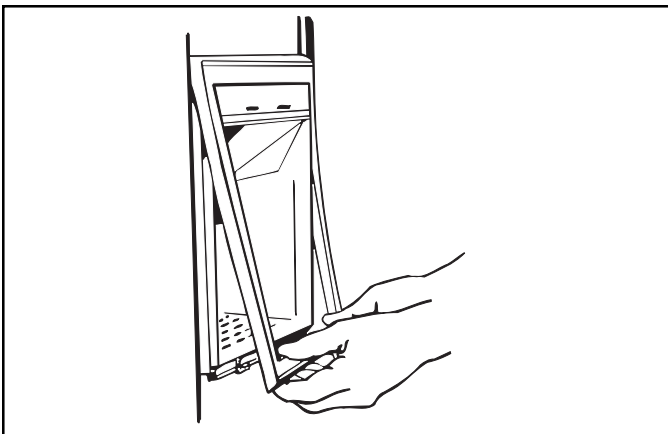

3. Remove door handle inserts by placing screwdriver at top of door handles in area between handle and insert and pulling out.

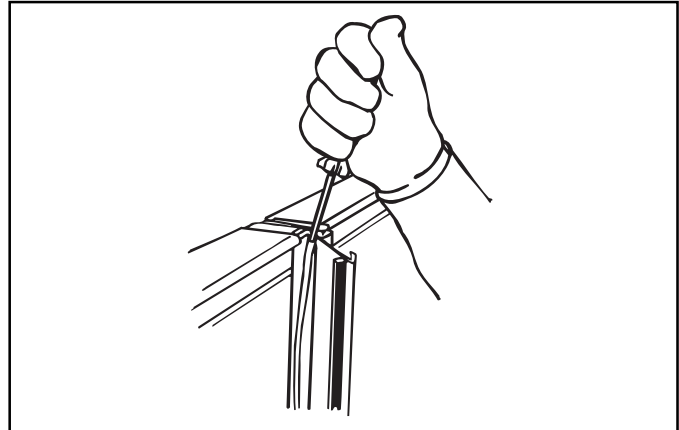

4. Pull inserts out along length of handles.

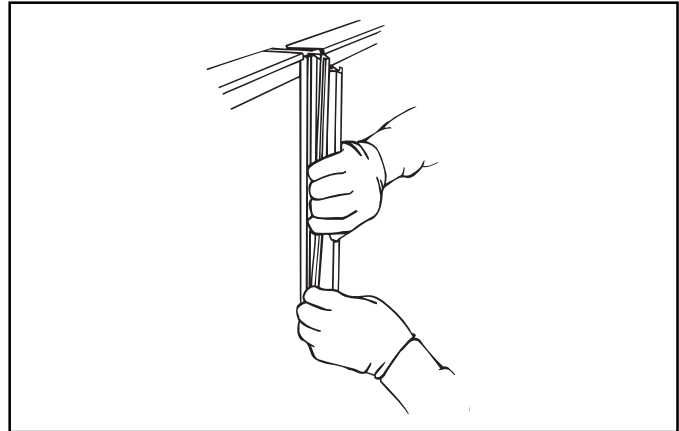

5. Install new handle inserts by reversing steps 3-4.

Important

One door handle insert (Item #7 or #8) will be discarded on DS23 kits.

6. Remove thin section on top handle end caps to allow room for panels. Discard section. Replace top handle end caps by placing end caps on handles. Insert and tighten screws.

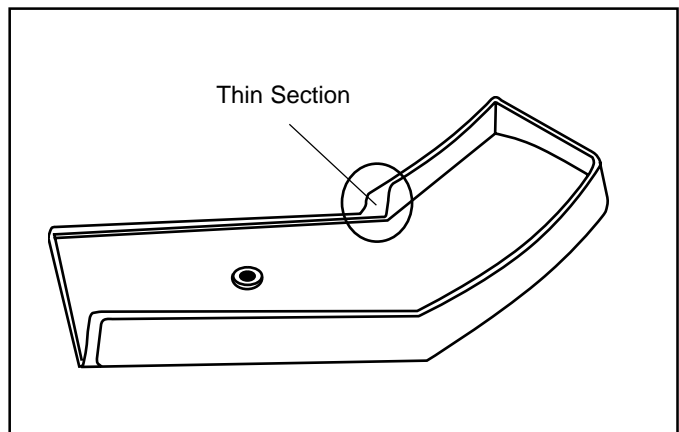

Kit Instructions

7. Dispenser Models

Replace dispenser cover by snapping in place. Insert and tighten screws. Replace switch by snapping in place.

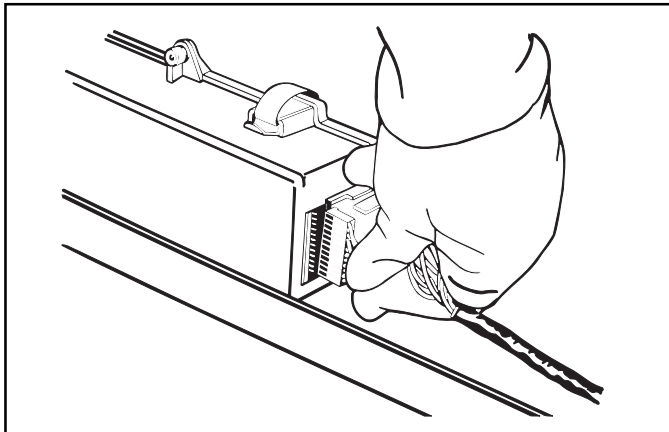

Trace around top hinges with a pencil. This helps alignment when reassembling. On electronic and dispenser models, unplug top hinge wire connectors. Remove top hinge screws.

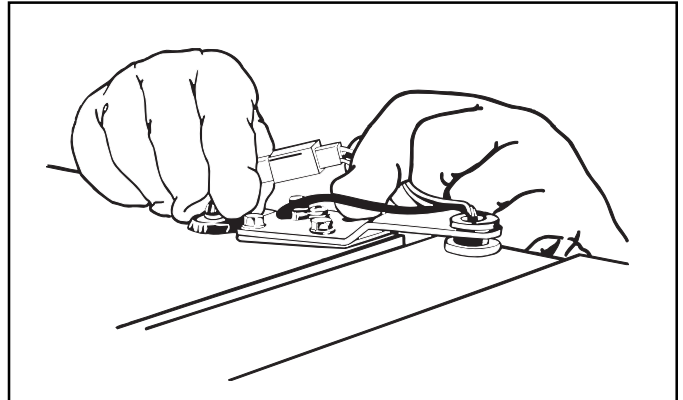

8. Remove toe grille by pulling forward.

9. Electronic Control Models

Unplug wiring harness from voltage box in center of refrigerator cabinet behind toe grille.

10. Electronic Control Models

Release wiring harness from plastic retainer clips on bottom of refrigerator cabinet. Open door approximately 120° and locate screw holding plastic door closure to top of bottom hinge. Remove screw and close door.

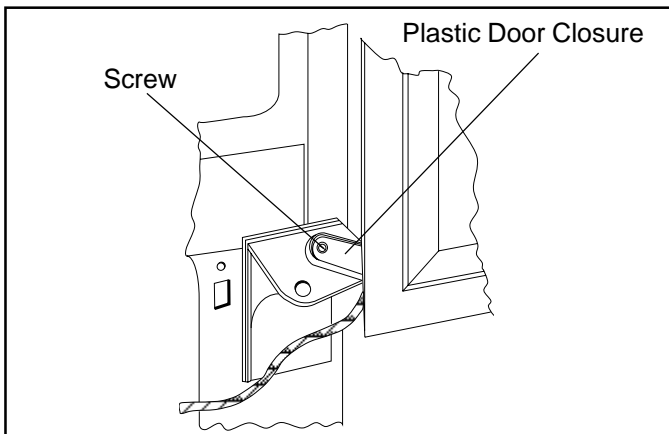

WARNING

To avoid electrical shock which can cause severe personal injury or death, green ground wire must remain attached to hinge.

13. Remove tape from refrigerator door. Grasp refrigerator door securely and lift up while opening. This will free door from bottom hinge pin. Top hinge may come off door. On electronic control models, wiring harness must slide through slot in bottom hinge.



Caution

To avoid property damage, drain water from water tube into small bucket.

14. Dispenser Models

Loosen water tube clamp screw. Loosen plastic water tube union nut. Gently pull water tube away from union nut and through tube clamp.

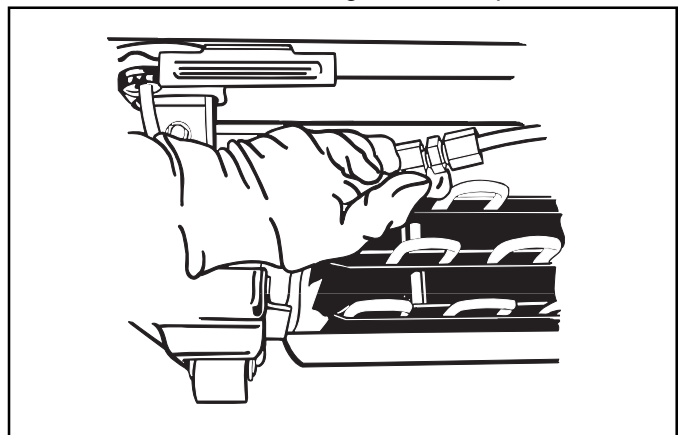

Caution

To avoid personal injury or property damage, temporarily tape doors shut.

11. Tape doors shut using masking tape.

12. Remove top hinge covers by removing screws.

Kit Instructions

15. Remove tape from freezer door. Grasp freezer door securely and lift up while opening. This will free door from bottom hinge pin. On dispenser models, plastic water tube must slide through slot in bottom door hinge as door is raised.
16. Remove door stops by removing screws. Install spacer and bottom trim by placing spacer and trim on bottom of doors. Insert and tighten bottom trim screws (Item #9). Replace door stops by placing door stops on bottom of doors. Insert and tighten screws.

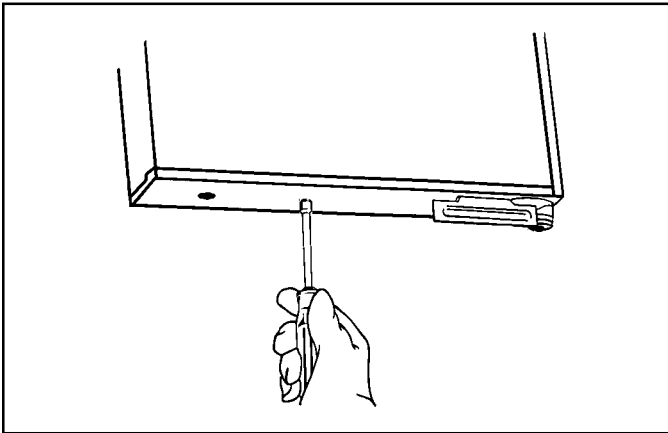

17. Rehang doors by positioning bottom sockets onto bottom door hinge pins. Position so doors are flush with side of refrigerator cabinet. Handle side of doors should be approximately 1/8 inch (3.2 millimeters) higher than hinge side of doors. Doors will settle when loaded with food. On electronic control models, when replacing refrigerator door, thread wiring harness in slot in bottom hinge. On dispenser models, when replacing freezer door, thread water tube through bottom hinge pin and water tube clamp.

Caution

To avoid personal injury or property damage, temporarily tape doors shut.

18. Tape doors shut using masking tape.
19. Replace top hinges by placing top hinges on refrigerator. Insert and tighten screws. On electronic control and dispenser models, reconnect top hinge wire connectors by snapping together. Replace top hinge covers by placing hinge covers over hinges. On electronic control and dispenser models, carefully place wires under cover to avoid pinching wires. Insert and tighten screws.

WARNING

To avoid electrical shock which can cause severe personal injury or death, green ground wire must be reattached to refrigerator or freezer door hinge.

20. Remove tape from doors.

Important

Permanent, double-sided tape is used to attach some trim pieces to refrigerator. Before removing paper backing, check placement of trim pieces on refrigerator. Trim pieces may be damaged if adjustment or removal is attempted after installation.

21. Install top door trim by peeling off 1 1/2 inches (38 millimeters) of backing. Place cut end of trim against handle cap and firmly against back of door. After checking placement, peel off backing and press into place.
22. **Dispenser Models**
Install dispenser trim on freezer panels by sliding trim on bottom edge of upper freezer door panel and top edge of lower freezer door panel.
23. **Non Dispenser Models**
Remove nameplate by placing putty knife covered with masking tape under nameplate and pulling forward. Discard nameplate.
24. Slide decorator door panels into place until panels are secure under handle inserts.

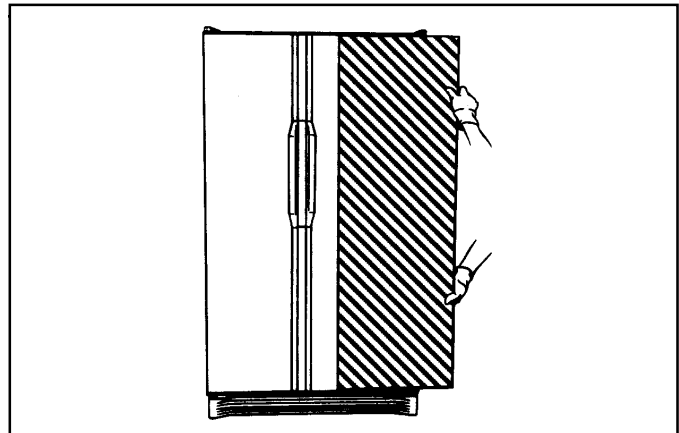

25. Install side door trim by peeling off 1 1/2 inches (38 millimeters) of backing. Place trim against top corner of refrigerator cabinet over edge of top trim. After checking placement, peel off backing and press into place. Place side door trim over edge of bottom trim.

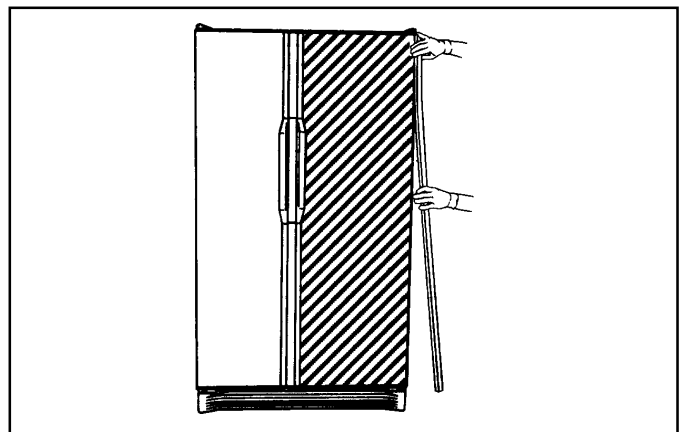

Kit Instructions

26. Dispenser Models

Push water tube into plastic union nut and tighten union nut by hand. Gently pull on tube to confirm nut is tight. Tighten water tube clamp screw.



Caution

To avoid property damage, confirm water tube union nut is secure before replacing toe grille.

27. Electronic Control Models

Plug wiring harness into voltage box in center of refrigerator cabinet behind toe grille. Snap wiring harness into plastic retainer clips on bottom of refrigerator cabinet. Align hole in plastic door closure with hole in bottom hinge. Insert and tighten screw.

28. Replace toe grille by inserting clips in holes and snapping in.

Kit Instructions

PK201 and PKD201 1/4" Decorator Door Panel Kits

Parts List

Description	Qty	PK201E (Black)	PK201W (White)	PKD201E (Black)	PKD201W (White)
Refrigerator door panel	1	10096944	10096940	10096944	10096940
Freezer door panel	1	10096943	10096939		
Freezer door upper panel	1			10096949	10096945
Freezer door lower panel	1			10096986	10096983
Refrigerator door spacer	1	10234611	10234611	10234611	10234613
Freezer door spacer	1	10234612	10234612		
Freezer door upper spacer	1			10234609	10234609
Freezer door lower spacer	1			10234625	10234625
Installation instructions	1	10599708	10599708	10599708	10599708

Introduction



CAUTION

To avoid personal injury and property damage, observe all safety instructions.



CAUTION

To avoid property damage, protect soft vinyl or other flooring with cardboard, rugs, or other protective material.

Read entire manual before installing kit. Confirm all parts listed are included in kit. If parts are missing, contact source from whom kit was purchased.

Important

- Mechanical experience is required to install trim kit.
- Depending on installer's knowledge and skill, installation can take from one-half to one hour.
- If unable to solve a problem during installation, contact source from whom kit was purchased.

Procedure



CAUTION

To avoid personal injury, protect hands and arms. Trim pieces may have sharp edges.

Important

Save all screws and reuse in original location.

1. Remove top handle end caps by removing screws.

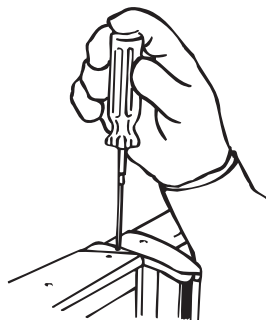

2. **Dispenser Models**

Remove crushed/cubed ice switch cover on dispenser by pulling forward. Remove screws from bottom of dispenser cover. Release bottom clips on dispenser cover by placing taped edge of putty knife underneath cover and pulling out. Release top clips by holding bottom of dispenser cover out and sliding up.

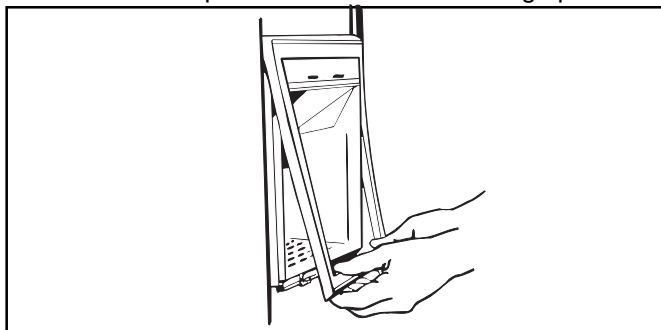

Kit Instructions

3. Remove door handle inserts by placing screwdriver at top of door handles in area between handle and insert and pulling forward.

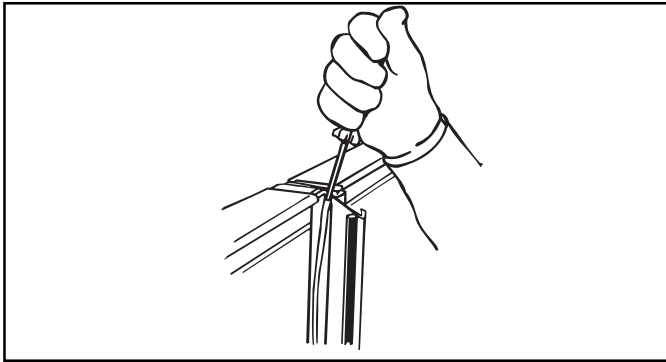

4. Pull edge of inserts forward along length of handles.

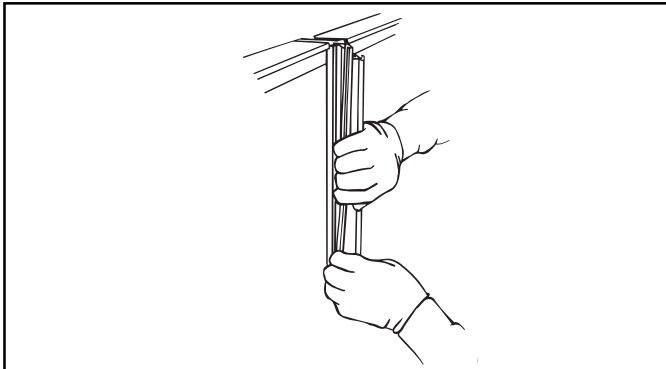

**CAUTION**

To avoid personal injury or property damage, hold handles when removing.

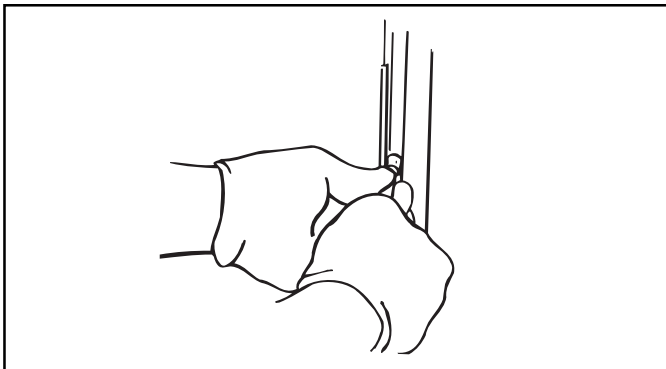

5. Remove door handles by removing screws.

Important

Do not remove cardboard from panels. Panels will not fit properly if cardboard is removed.

6. Dispenser Models

Locate dispenser trim in top crisper drawer. Install dispenser trim on freezer panels by sliding trim on bottom edge of upper freezer door panel and top edge of lower freezer door panel.

**CAUTION**

To avoid property damage, place masking tape on back of panel at each corner. Tape prevents panel from damaging doors.

7. Cover back edges of cardboard with masking tape. Place several evenly spaced strips of masking tape on rear of cardboard.

8. Non Dispenser Models

Open doors. Place bottom of panels in bottom trim then place top of panels under top trim. Slide panels into place until panels are seated firmly under side trim.

Dispenser Models

Open doors. Place bottom of refrigerator panel in bottom trim then place top of panel under top trim. Place bottom of lower freezer door panel in bottom trim then place top of panel under dispenser cavity. Place bottom of upper freezer door panel in top of dispenser cavity then place top of panel under top trim. Slide panels into place until panels are seated firmly under side trim.

9. Replace door handles by placing door handles on doors. Insert and tighten screws. Replace handle inserts by snapping in place.
10. **Dispenser Models**
Replace dispenser cover by snapping in place. Insert and tighten screws. Replace switch by snapping in place.
11. Remove thin section on top handle end caps to allow room for panels. Discard section. Replace top handle end caps by placing end caps on handles. Insert and tighten screws.

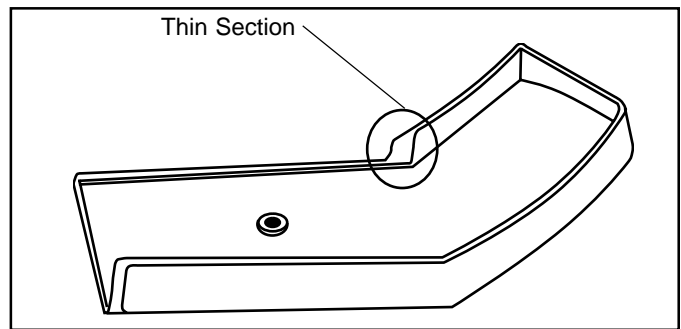

12. Peel protective wrap off front of panels.

Kit Instructions

HTGK200, HTGK220, HTK200 and Conversion Kits

Parts List

Description	Qty	HTK200E Black	HTK200S Brushed Aluminum	HTGK200W White	HTK220E Black	HTK220S Brushed Aluminum	HTGK220W White
Top Cap, Refrigerator Door	1	X	X	X	X	X	X
Top Cap, Freezer Door	1	X	X	X	X	X	X
Bottom Cap, Refrigerator Door	1	X	X	X	X	X	X
Bottom Cap, Freezer Door	1	X	X	X	X	X	X
Hinge Cover, Right	1	X	X	X	X	X	X
Hinge Cover, Left	1	X	X	X	X	X	X
Side Trim, Refrigerator Door	1	X	X	X	X	X	X
Side Trim, Freezer Door	1	X	X	X	X	X	X
Top Trim, Refrigerator Door	1	X	X	X	X	X	X
Top Trim, Freezer Door	1	X	X	X	X	X	X
Bottom Trim, Refrigerator Door	1	X	X	X	X	X	X
Bottom Trim, Freezer Door	1	X	X	X	X	X	X
Trim, Dispenser	2	X	X	X			
Door Stop	2		X	X		X	X
Handle, Freezer Door	1	X	X	X	X	X	X
Handle, Refrigerator Door	1	X	X	X	X	X	X
Toe Grille	1			X			X
Handle Insert, Refrigerator Door	1	X	X	X	X	X	X
Handle Insert, Freezer Door	1	X	X	X	X	X	X
Screw, Top Trim	6	X			X		
Installation Instructions	1	X	X	X	X	X	X
Clip, Toe Grille	2			X			X
Tape, Double Back	122"	X	X	X	X	X	X

Kit Instructions

Introduction

Important

- Mechanical experience is required to install trim kit.
- Depending on installer's knowledge and skill, installation can take from one to three hours.
- Transfer food to an alternate cooling source. Check refrigerator warranty certificate for specific coverage. **Warranty does not cover food loss.**
- Ensure trim pieces adhere properly by confirming surfaces are clean, dry and free of adhesive residue.
- If unable to solve a problem during installation, contact source from whom kit was purchased.

Decorator Panel Dimensions

Listed below are required height x width dimensions for decorator panels. Panels are not supplied with this kit and can be purchased locally.



Caution

To avoid personal injury or property damage, refrigerator panels should not weigh more than 30 pounds (14 kilograms) and freezer panels should not weigh more than 15 pounds (7 kilograms).

Without Dispenser

Refrigerator Door	63 3/32" x 19 3/8" (1603 mm x 492 mm)
Freezer Door	63 3/32" x 13 3/4" (1603 mm x 349 mm)

With Dispenser

Refrigerator Door	63 3/32" x 19 3/8" (1603 mm x 492 mm)
Upper Freezer Door	18 3/8" x 13 3/4" (467 mm x 349 mm)
Lower Freezer Door	31 13/16" x 13 3/4" (808 mm x 349 mm)

Procedure



Caution

To avoid personal injury or property damage, two people should remove and rehang each door.



Caution

To avoid personal injury, protect hands and arms. Trim pieces may have sharp edges.

Important

Save all screws and reuse in original location.

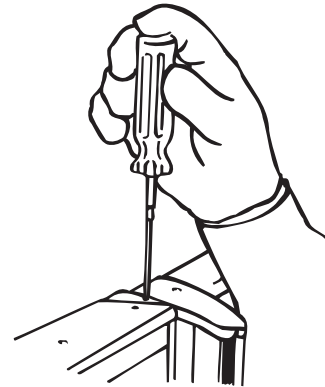

1. Remove top handle end caps by removing screws.

2. Dispenser Models

Remove crushed/cubed ice switch cover on dispenser by pulling forward. Remove screws from bottom of dispenser cover. Release bottom clips on dispenser cover by placing taped edge of putty knife underneath cover and pulling out. Release top clips by holding bottom of dispenser cover out and slide upward.

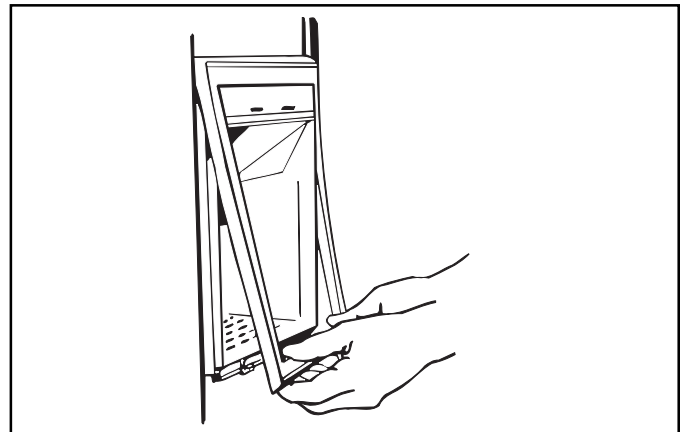

Kit Instructions

3. Remove door handle inserts by placing screwdriver at top of door handles in area between handle and insert and pulling out.

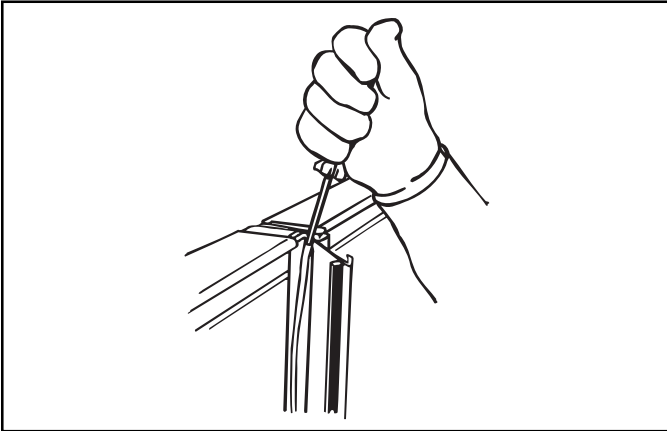

4. Pull edge of inserts forward along length of handles.

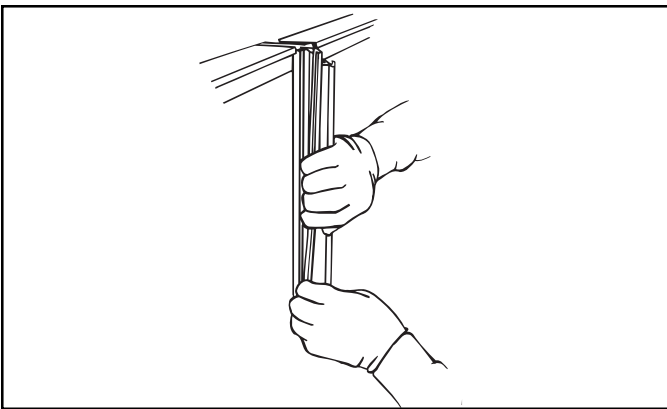

To avoid personal injury or property damage, hold handles when removing.

5. Remove door handles by removing screws. Bottom inserts are removed with handle.

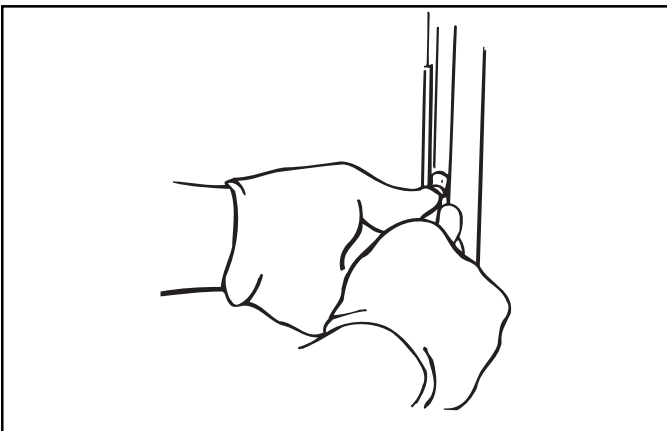

6. Remove top door trim by removing screws.
7. If refrigerator has decorator panels, carefully slide panels out. On dispenser models, remove dispenser trim.

8. Remove trim on sides of doors by placing taped edge of putty knife underneath trim and pulling out.

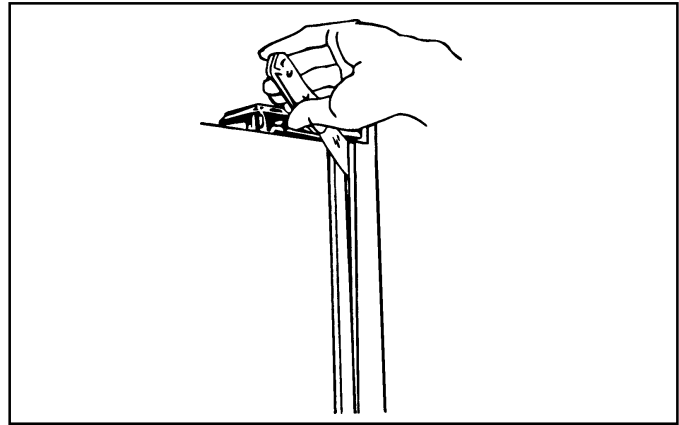

To avoid personal injury or property damage, temporarily tape doors shut.

9. Tape doors shut using masking tape.
10. Remove top hinge covers by removing screws. Trace around top hinges with a pencil. This helps alignment when reassembling. On dispenser models, unplug top hinge wire connectors. Remove top hinge screws.

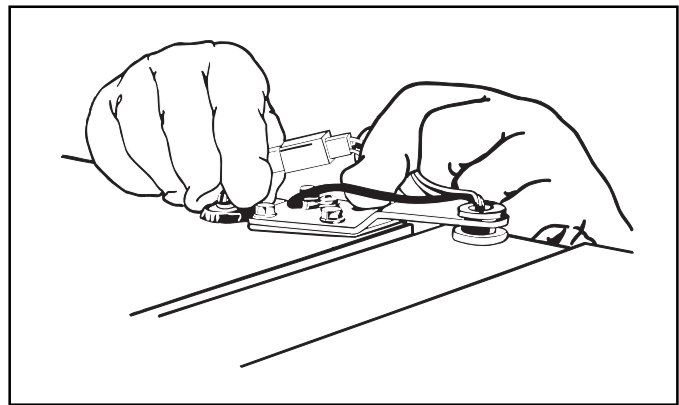

To avoid electrical shock which can cause severe personal injury or death, green ground wire must remain attached to hinge.

11. Remove tape from refrigerator door. Grasp refrigerator door securely and lift up while opening. This will free door from bottom hinge pin. Top hinge may come off door.
12. Remove toe grille by pulling forward.

Kit Instructions



Caution

To avoid property damage, drain water from water tube into small bucket.

13. Dispenser Models

Loosen water tube clamp screw. Loosen plastic water tube union nut. Gently pull water tube away

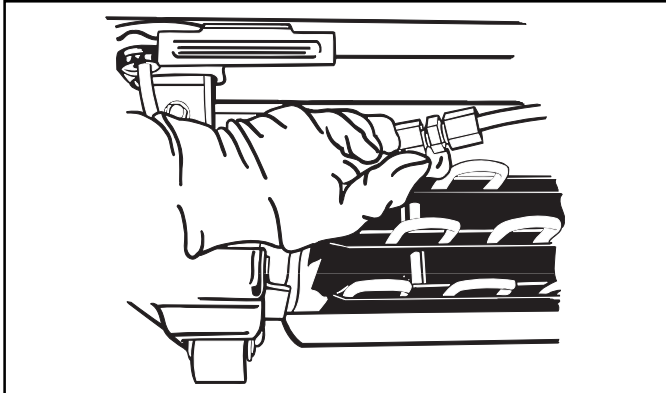

from union nut and through tube clamp.

14. Remove tape from freezer door. Grasp freezer door securely and lift up while opening. This will free door from bottom hinge pin. On dispenser models, plastic water tube must slide through slot in bottom door hinge as door is raised. Top hinge will remain attached to door.
15. Remove bottom door trim by removing screws. When installing HTK200S, HTGK200W, HTK220S and HTK220W kits, remove door stops. Confirm support plate is under door trim. Install new bottom door trim by placing trim on bottom of doors. Insert and tighten screws. When installing HTK200S, HTGK200W, HTK220S and HTK220W kits, install new door stops by placing door stops on bottom of doors. Insert and tighten screws.

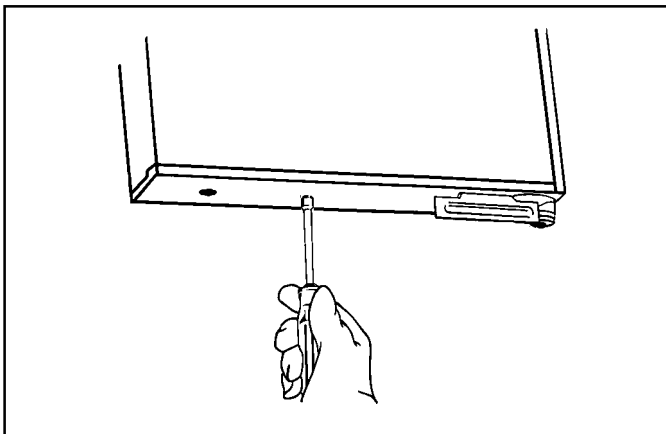

16. Rehang doors by positioning bottom sockets onto bottom door hinge pins. Position so doors are flush with sides of refrigerator cabinet. Handle side of doors should be approximately 1/8 inch (3.2 millimeters) higher than hinge side of doors. Doors will settle when loaded with food. On dispenser models, when replacing freezer door, thread water tube through bottom hinge pin and water tube clamp.



Caution

To avoid personal injury or property damage, temporarily tape doors shut.

17. Tape doors shut using masking tape.

Important

- Ensure trim pieces adhere properly by confirming surfaces are clean, dry and free of adhesive residue.
- Discard factory installed trim and handles.

18. Replace top hinges by placing top hinges on refrigerator. Insert and tighten screws. On dispenser models, reconnect top hinge wire connectors. Install new top hinge covers by placing hinge covers over hinges. On dispenser models, carefully place wires under cover to avoid pinching wires. Insert screws and tighten.



WARNING

To avoid electrical shock which can cause severe personal injury or death, green ground wire must be attached to freezer door hinge.

19. Install new bottom door handle caps by pushing up into bottom of new handles until caps snap in place.
20. Install new door handles by placing door handles on door. Insert and tighten screws. Install new handle inserts by snapping in place.

Kit Instructions

21. Remove thin section on top handle end caps to allow room for panels. Discard section. Replace top handle end caps by placing end caps on handles. Insert and tighten screws.

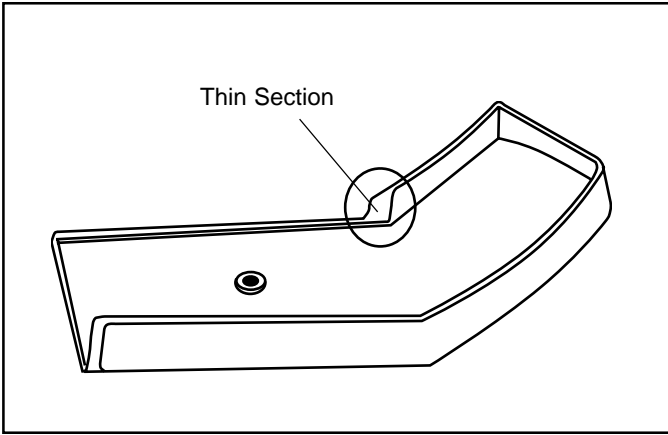

22. Dispenser Models

Replace dispenser cover by snapping in place. Insert and tighten screws. Replace switch by snapping in place.

23. Install new top door trim by placing trim on top of doors. Insert screws but do not completely tighten. When installing HTK200E and HTK220E, install new color coordinated screws taped to trim.

24. Dispenser Models

Install new dispenser trim on freezer panels by sliding trim on bottom edge of upper freezer door panel and top edge of lower freezer door panel.

25. Slide decorator door panels into place until panels are secure under door handle inserts.

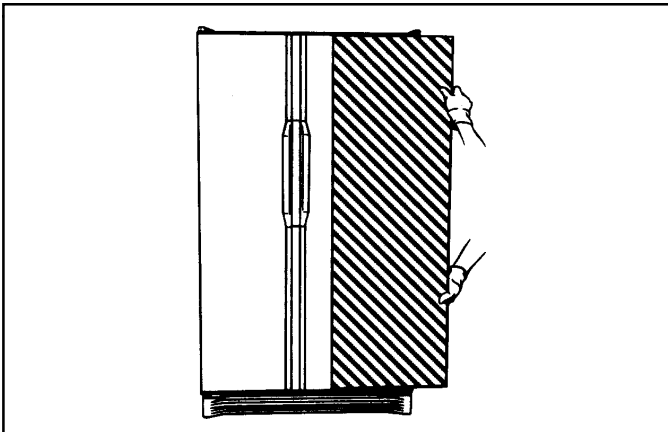

Important

Permanent, double-sided tape is used to attach some trim pieces to refrigerator. Before removing paper backing, check placement of trim pieces on refrigerator. Trim pieces may be damaged if adjustment or removal is attempted after installation.

26. Install side door trim by peeling off 1 1/2 inches (38 millimeters) of backing. Place trim against bottom corner of refrigerator cabinet over edge of bottom trim. After checking placement, peel off backing and press into place. Place side door trim under edge of top trim. Tighten top trim screws.

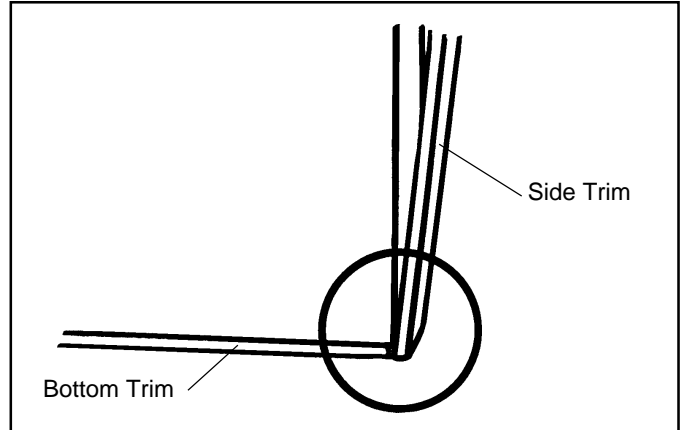

27. Push water tube into plastic union nut and tighten union nut by hand. Gently pull on tube to confirm nut is tight. Tighten water tube clamp screw.



Caution

To avoid property damage, confirm water tube union nut is secure before replacing toe grille.

28. Install new toe grille (if supplied) by inserting clips in holes and snapping in.

Kit Instructions

HTGK100 and HTGK110 Black 1/4" Trim and Handle Conversion Kits

Introduction

Important

- Mechanical experience is required to install trim kit.
- Depending on installer's knowledge and skill, installation can take from one to three hours.
- Transfer food to an alternate cooling source. Check refrigerator warranty certificate for specific coverage. **Warranty does not cover food loss.**
- Ensure trim pieces adhere properly by confirming surfaces are clean, dry and free of adhesive residue.
- If unable to solve a problem during installation, contact source from whom kit was purchased.

Decorator Panel Dimensions

Listed below are required height x width dimensions for decorator panels. Panels are not supplied with this kit and can be purchased locally.

 Caution
<p>To avoid personal injury or property damage, refrigerator panels should not weigh more than 30 pounds (14 kilograms) and freezer panels should not weigh more than 15 pounds (7 kilograms).</p>

Without Dispenser

Refrigerator Door 61 15/16" x 19 3/8"
(1573 mm x 492 mm)

Freezer Door 61 15/16" x 13 3/4"
(1573 mm x 349 mm)

With Dispenser

Refrigerator Door 61 15/16" x 19 3/8"
(1573 mm x 492 mm)

Upper Freezer Door 17 1/4" x 13 3/4"
(438 mm x 349 mm)

Lower Freezer Door 31 13/16" x 13 3/4"
(808 mm x 349 mm)

Parts List

Description	Qty	HTGK100E Black	HTGK110E BLACK
Top Cap, Refrigerator Door	1	X	X
Top Cap, Freezer Door	1	X	X
Bottom Cap, Refrigerator Door	1	X	X
Bottom Cap, Freezer Door	1	X	X
Hinge Cover	2	X	X
Toe Grille	1	X	X
Side Trim, Refrigerator and Freezer Doors	2	X	X
Door Stop	2	X	X
Top Trim, Refrigerator Door	1	X	X
Top Trim, Freezer Door	1	X	X
Bottom Trim, Refrigerator Door	1	X	X
Bottom Trim, Freezer Door	1	X	X
Trim, Dispenser	2	X	
Handle, Refrigerator Door	1	X	X
Handle, Freezer Door	1	X	X
Handle Insert, Refrigerator Door	1	X	X
Handle Insert, Freezer Door Handle	1	X	X
Installation Instructions	1	X	X
Screw, Bottom Trim	5	X	X
Spacer, Refrigerator Bottom Trim	1	X	X
Spacer, Freezer Bottom Trim	1	X	X
Clip, Toe Grille	2	X	X
Tape, Double Back .032"	28.5"	X	X
Tape, Double Back .187"	122"	X	X

Kit Instructions

Procedure



Caution

To avoid personal injury or property damage, two people should remove and rehang each door.



Caution

To avoid personal injury, protect hands and arms. Trim pieces may have sharp edges.

Important

Save all screws and reuse in original location.

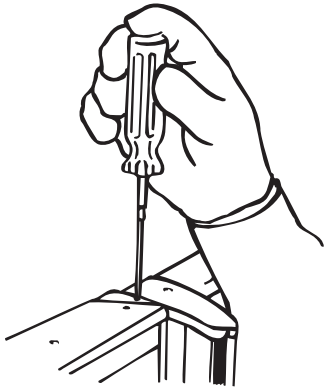

1. Remove top handle end caps by removing screws.

2. Dispenser Models

Remove crushed/cubed ice switch cover on dispenser by pulling forward. Remove screws from bottom of dispenser cover. Release bottom clips on dispenser cover by placing taped edge of putty knife underneath cover and pulling out. Release top clips by holding bottom of dispenser cover out and slide upward.

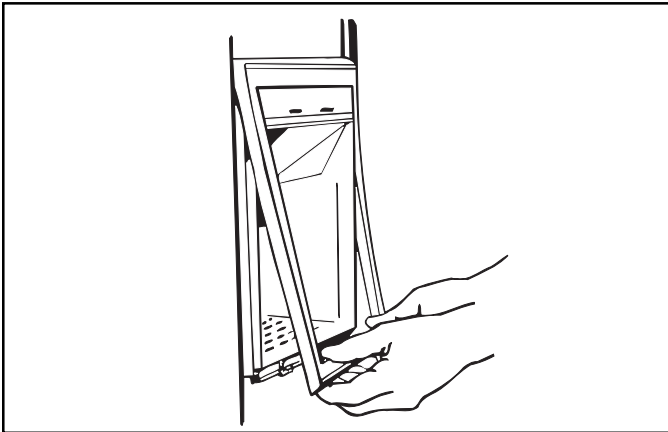

3. Remove door handle inserts by placing screwdriver at top of door handles in area between handle and insert and pulling out.

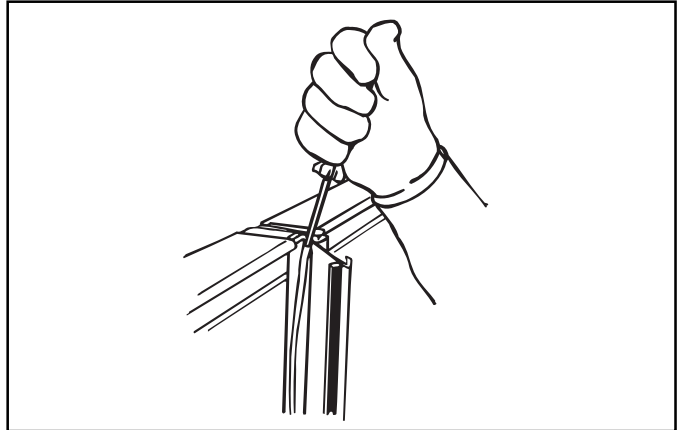

4. Pull edge of inserts forward along length of handles.

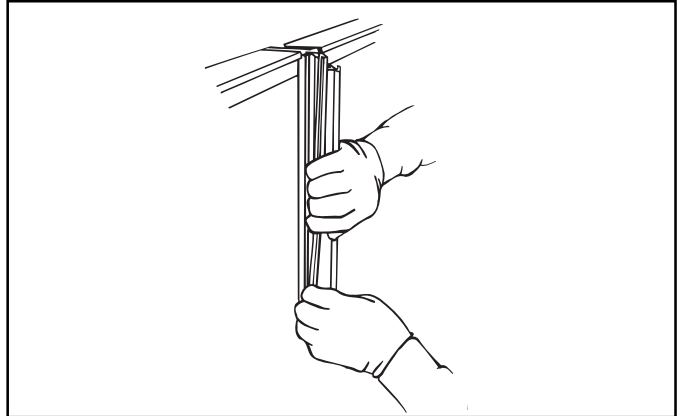

Caution

To avoid personal injury or property damage, hold handles when removing.

5. Remove door handles by removing screws. Bottom inserts are removed with handle.

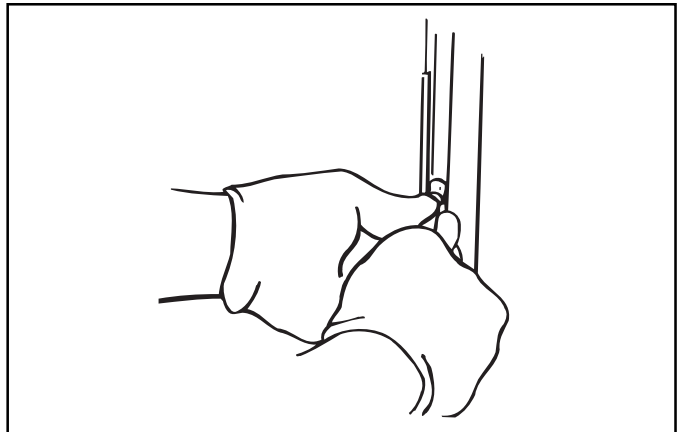

Kit Instructions



Caution

To avoid personal injury or property damage, temporarily tape doors shut.

6. Tape doors shut using masking tape.
7. Remove top hinge covers by removing screws. Trace around top hinges with a pencil. This helps alignment when reassembling. On dispenser models, unplug top hinge wire connectors. Remove top hinge screws.

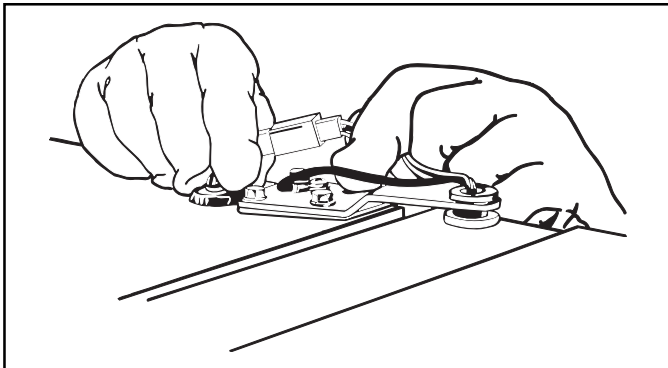

WARNING

To avoid electrical shock which can cause severe personal injury or death, green ground wire must remain attached to hinge.

8. Remove tape from refrigerator door. Grasp refrigerator door securely and lift up while opening. This will free door from bottom hinge pin. Top hinge may come off door.
9. Remove toe grille by pulling forward.



Caution

To avoid property damage, drain water from water tube into small bucket.

10. Dispenser Models

Loosen water tube clamp screw. Loosen plastic water tube union nut. Gently pull water tube away from union nut and through tube clamp.

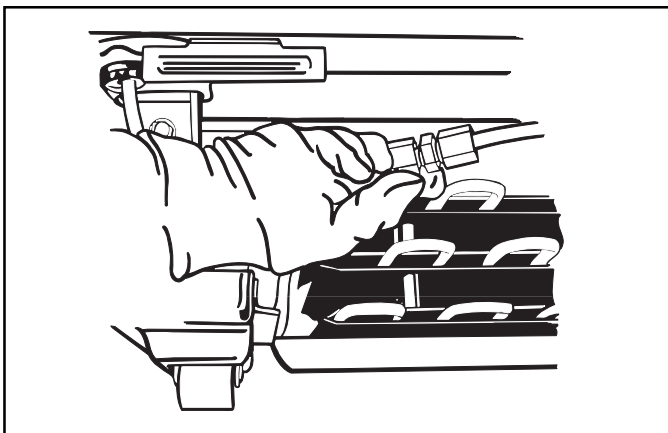

11. Remove tape from freezer door. Grasp freezer door securely and lift up while opening. This will free door from bottom hinge pin. On dispenser models, plastic water tube must slide through slot in bottom door hinge as door is raised. Top hinge will remain attached to door.
12. Remove door stops by removing screws. Install spacer and bottom trim by placing spacer and trim on bottom of both doors. Insert screws and tighten. Install new door stops by placing door stops on both doors. Insert and tighten screws.

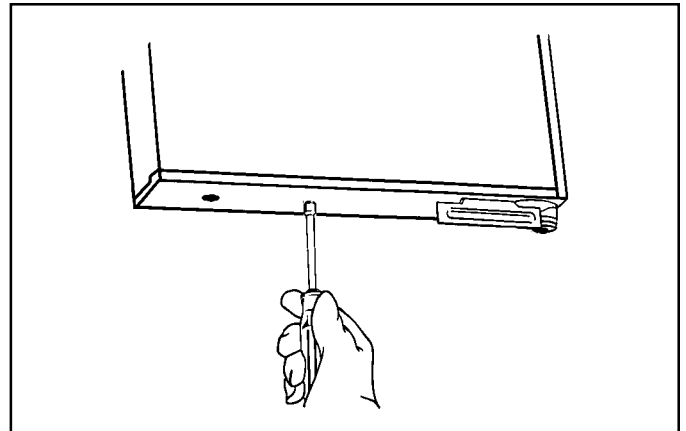

13. Rehang doors by positioning bottom sockets onto bottom door hinge pins. Position so doors are flush with sides of refrigerator cabinet. Handle side of doors should be approximately 1/8 inch (3.2 millimeters) higher than hinge side of doors. Doors will settle when loaded with food. On dispenser models, when replacing freezer door, thread water tube through bottom hinge pin and water tube clamp.



Caution

To avoid personal injury or property damage, temporarily tape doors shut.

14. Tape doors shut using masking tape.
15. Replace top hinges by placing top hinges on refrigerator. Insert screws and tighten. On dispenser models, reconnect top hinge wire connectors. Install new top hinge covers by placing hinge covers over hinges. On dispenser models, carefully place wires under cover to avoid pinching wires. Insert and tighten screws.

Kit Instructions



WARNING

To avoid electrical shock which can cause severe personal injury or death, green ground wire must remain attached to freezer door hinge.

16. Install new bottom door handle caps by pushing up into bottom of new handle until caps snap in place.
17. Install new door handles by placing door handles on door. Insert and tighten screws. Install new handle inserts by snapping in place.
18. Remove thin section on end caps to allow room for panels. Discard section. Replace top end caps by placing end caps on handles. Insert and tighten

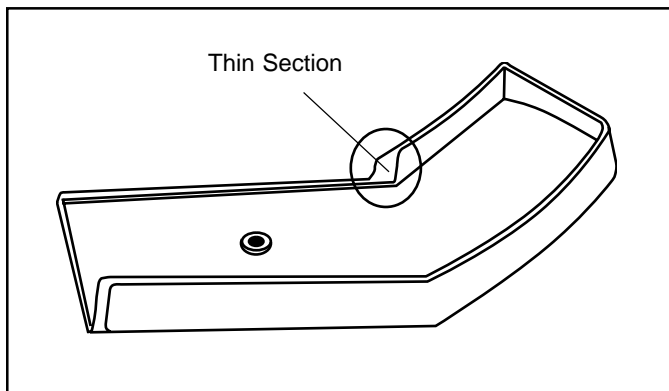

screws.

19. Dispenser Models

Replace dispenser cover by snapping in place. Insert and tighten screws. Replace switch by snapping in place.

Important

Permanent, double-sided tape is used to attach some trim pieces to refrigerator. Before removing paper backing, check placement of trim pieces on refrigerator. Trim pieces may be damaged if adjustment or removal is attempted after installation.

20. Install new top door trim by peeling off 1 1/2 inches (38 millimeters) of backing. Place trim firmly against top handle cap and against back of door. After checking placement, peel off backing and press into place.
21. **Dispenser Models**
Install new dispenser trim on freezer panels by sliding trim on bottom edge of upper freezer door panel and top edge of lower freezer door panel.
22. **Non Dispenser Models**
Remove nameplate by placing putty knife covered with masking tape under nameplate and pulling forward. Discard nameplate.

23. Slide decorator door panels into place until panels are secure under handle inserts.

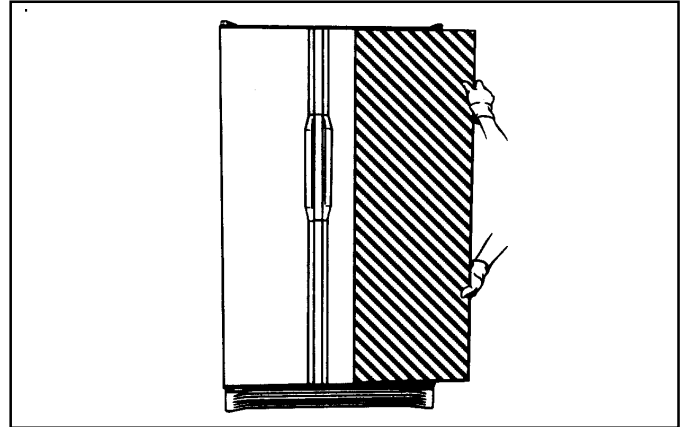

24. Install side door trim by peeling off 1 1/2 inches (38 millimeters) of backing. Place trim against top corner of refrigerator cabinet over edge of top trim. After checking placement, peel off backing and press into place. Place side door trim over edge of bottom trim.

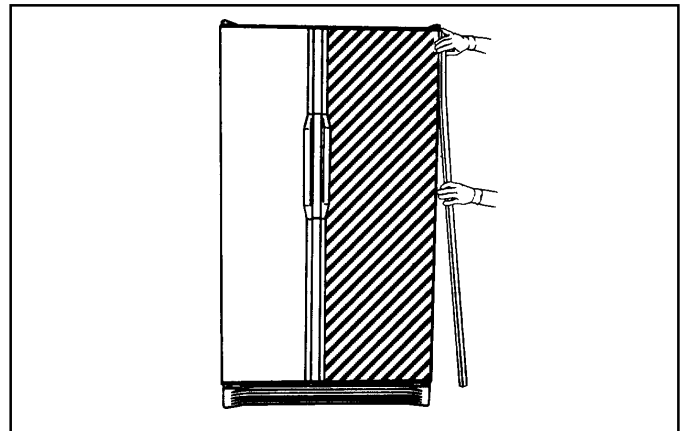

25. Push water tube into plastic union nut and tighten union nut by hand. Gently pull on tube to confirm nut is tight. Tighten water tube clamp screw.



Caution

To avoid property damage, confirm water tube union nut is secure before replacing toe grille.

26. Install new toe grille inserting clips in holes and snapping in.

Kit Instructions

BI10, BI11, BI12, BI13 Perimeter Trim Kits

Introduction

Important

- Mechanical experience is required to install trim kit.
- Depending on installer's knowledge and skill, installation can take from one-half to one hour.
- If unable to solve a problem during installation, contact source from whom kit was purchased.

Parts List

Item	Description	Qty
1	L-shaped Bezel Gusset	2
2	Bezel Gusset Machine Screw	4
3	Right Cabinet Frame	1
4	Left Cabinet Frame	1
5	Top Cabinet Frame	1

Procedure



To avoid personal injury, protect hands and arms. Trim pieces may have sharp edges.

1. Identify cabinet opening where opening is a minimum of 69" (1753 mm) high, 24" (610 mm) deep and 36" (914 mm) wide. Front corners of counter top may need to be trimmed at a 45° angle so doors will open completely.

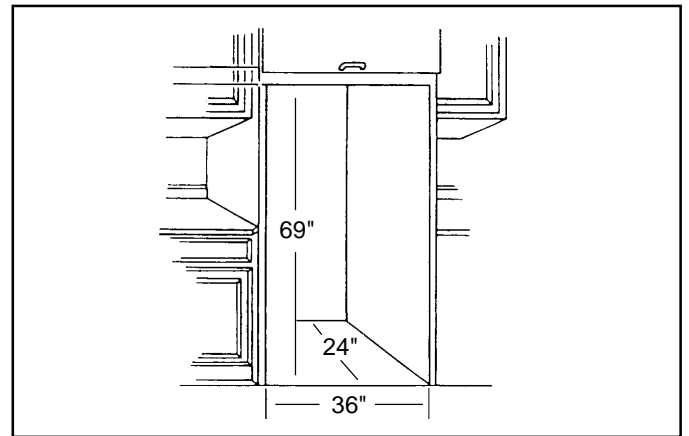

2. Level refrigerator in cabinet opening according to instructions in Owner's Manual. Roll refrigerator out of opening to install kit.
3. Slide a L-shaped bezel gusset into end of left and right frame. Insert screws and tighten.

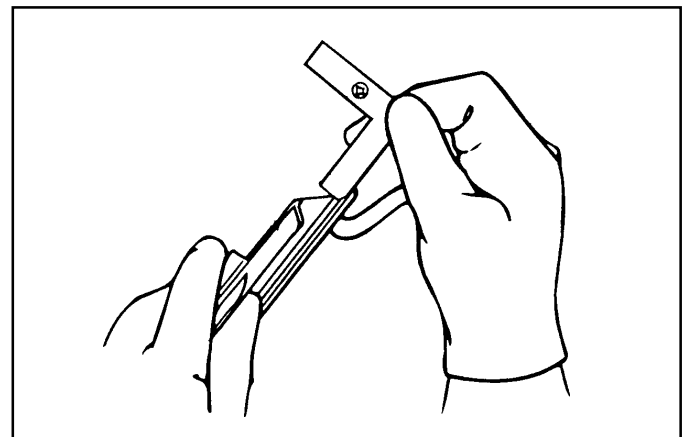

Kit Instructions

- Slide bezel gusset from left frame into channel on one end of top trim. Slide bezel gusset from right frame into channel on other end of top trim. Confirm trim is aligned properly at mitered corners. If mitered corners do not fit properly, remove left and right frames and make necessary adjustments.

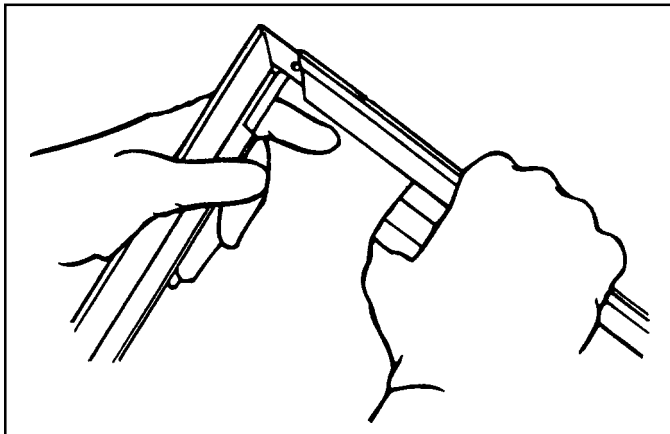

- Center top frame between top hinge covers. Confirm front of trim is secure against front of refrigerator cabinet.

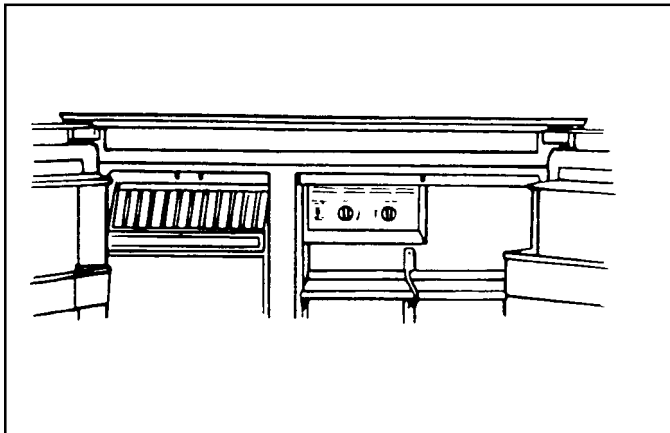

- Install top frame on refrigerator cabinet by removing paper backing from velcro patches and pressing tightly into place.

Important

Top frame may be removed. Remove top frame by gently lifting top frame. Replace top frame by pressing tightly into place. Side frames cannot be removed.

- Align front edge of left and right frames along left and right edges of refrigerator cabinet.

- Slide bezel gusset on left frame into top frame. Slide bezel gusset on right frame into top frame. Confirm trim is aligned properly and mitered corners are tight.

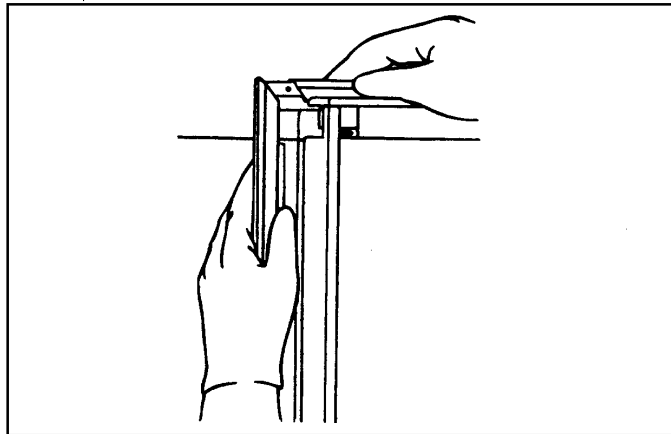

Important

Permanent, double-sided tape is used to attach some pieces to refrigerator. Before removing paper backing, check placement of pieces on refrigerator. Pieces may be damaged if adjustment or removal is attempted after installation.

- Install left and right frames by peeling off 1 1/2" (38 millimeters) of backing. Press frames firmly on refrigerator. After checking placement, peel off backing and press into place.
- Secure left and right frames to top frame by inserting and tightening screws.

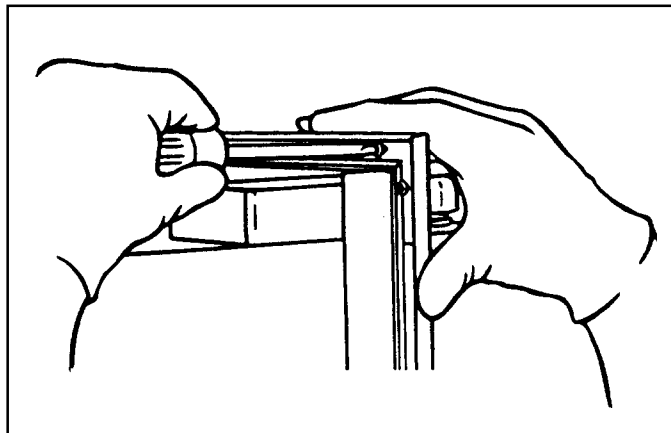

- Roll refrigerator into opening and check for proper fit with surrounding cabinets. Once proper fit is achieved, roll refrigerator out of opening; plug in power cord; and roll refrigerator back into opening.