

# **Thermador Built-In Refrigerator Training Program**



## **36 / 42 / 48 Inch Built-In Models**

- Model Numbers
- Features and Benefits
- Product Description
- Warranty
- Installation
- Operation
- Disassembly
- Reassembly
- Wiring Diagram
- Service Tips



# Understanding Built-In Model Numbers

**Example: K B U L T 36 71 A**

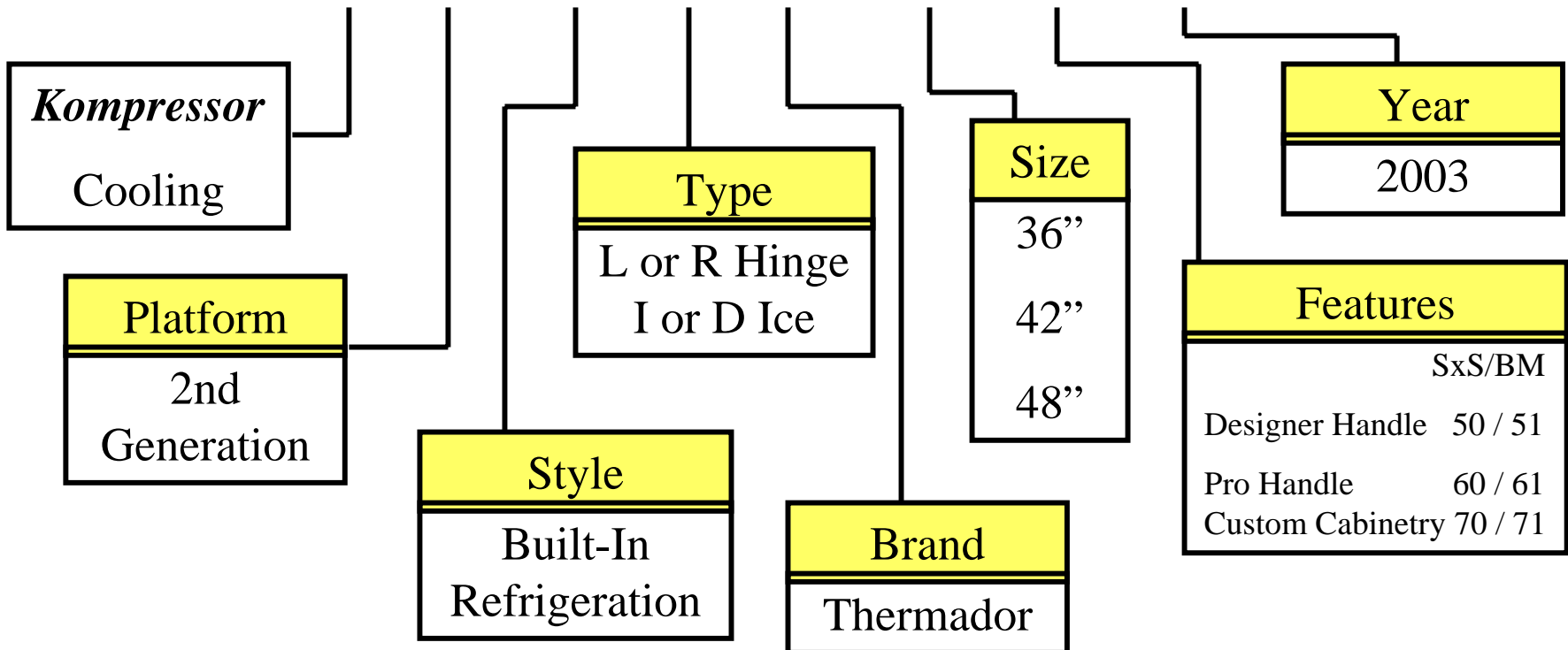

## **36 Inch Bottom Mount Built-In Models**

- KBULT3671A** Custom Panel, Left Hand Door Swing
- KBURT3671A** Custom Panel, Right Hand Door Swing
- KBULT3651A** Designer Handle, Stainless Exterior, Left Hand Door Swing
- KBURT3651A** Designer Handle, Stainless Exterior, Right Hand Door Swing
- KBULT3661A** Professional Handle, Stainless Exterior, Left Hand Door Swing
- KBURT3661A** Professional Handle, Stainless Exterior, Right Hand Door Swing

## **42 Inch (Side by Side) Built-In Models**

- KBUI4270A** Custom Panel, Internal Ice Maker
- KBUD4270A** Custom Panel, Exterior Dispensing
- KBUI4250A** Designer Handle, Stainless Exterior, Internal Ice Maker
- KBUD4250A** Designer Handle, Stainless Exterior, Exterior Dispensing
- KBUI4260A** Professional Handle, Stainless Exterior, Internal Ice Maker
- KBUD4260A** Professional Handle, Stainless Exterior, Exterior Dispensing

## **48 Inch (Side by Side) Built-In Models**

- KBUI4870A** Custom Panel, Internal Ice Maker
- KBUD4870A** Custom Panel, Exterior Dispensing
- KBUI4850A** Designer Handle, Stainless Exterior, Internal Ice Maker
- KBUD4850A** Designer Handle, Stainless Exterior, Exterior Dispensing
- KBUI4860A** Professional Handle, Stainless Exterior, Internal Ice Maker
- KBUD4860A** Professional Handle, Stainless Exterior, Exterior Dispensing

## **Features and Benefits**

- Electronic board, controlling both cooling and defrost operations
- Control allows Holiday Mode
- Motorized air door
- Refrigerator and freezer thermistors
- Low Noise 900 rpm condenser fan motor
- Condenser with Right to Left airflow
- Double pass heat loop in mullion
- Easy access to components
- In-Door Ice system
- Shield under inlet valve
- Foamed In Place (FIP) doors

# Product Description

## 36" Bottom Mount

- Automatic internal ice maker with easy to change water filter
- Elegant, adjustable frameless glass shelves offer increased storage capacity
- Integrated gallon door storage
- Humidity-sealed crispers
- Roller glides for easy drawer access
- Pull out freezer drawer with two large pull-out baskets





# Product Description

## 42" & 48" Side by Side

- Available with external ice and water dispenser or with internal ice maker
- Elegant adjustable frameless glass shelves
- Integrated gallon door storage
- Adjustable temperature meat storage drawer
- Humidity-controlled crispers
- Portable removable ice storage bucket (dispenser model only)
- Rapid chill freezer shelf (internal ice maker model only)



---

---

**Shelf Loads**

---

**Bottom Mount****42''****48''**

---

**Total Refrigerator  
Compartment Door****65 lbs****60 lbs****70 lbs**

---

**Interior Shelf****25lbs****35 lbs****45 lbs**

---

**Total Freezer  
Compartment Door****120 lbs****55 lbs****65 lbs**

---

# Warranty

- 2 years parts & labor from date of purchase or installation for the complete product
- 3rd through 6th year, parts & labor for the sealed system only
- 7<sup>th</sup> through 12<sup>th</sup> year parts only for the sealed system only
- For location of nearest repair depot call 1-800-735-4328 from 5:00 AM - 5:00 PM M-F (Pacific time)



# Warranty -- Serial # Label



Is located inside the refrigerator compartment on the right hand side up by the control

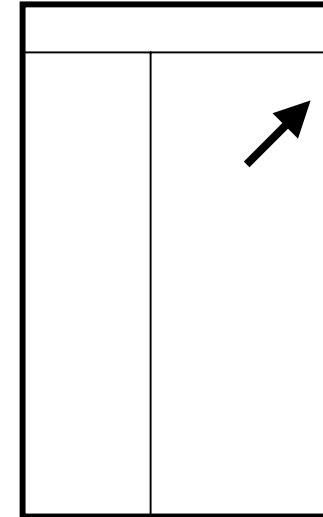

- Model # - "KBUIT4270A/01"
- Serial # FD 8311 001111

FD 8311 xxxxxx

- Serial # - "FD 8311". To find when the product type was built, add 20 to the 1st two digits to get the year (83 + 20 = 103 → product type was built in 2003). The last two digits show the month (11 = November).

## Installation

### Product Dimensions

#### Side View

The depth from the front of the top grille to the back of the refrigerator cabinet is 25 in. (64 cm).

The power cord is 24 in. (61 cm) long.

The water line attached to the back of the refrigerator is 5 ft. (1.5 m) long.

Height dimensions are shown with leveling legs extended in. (3 mm) below the rollers.

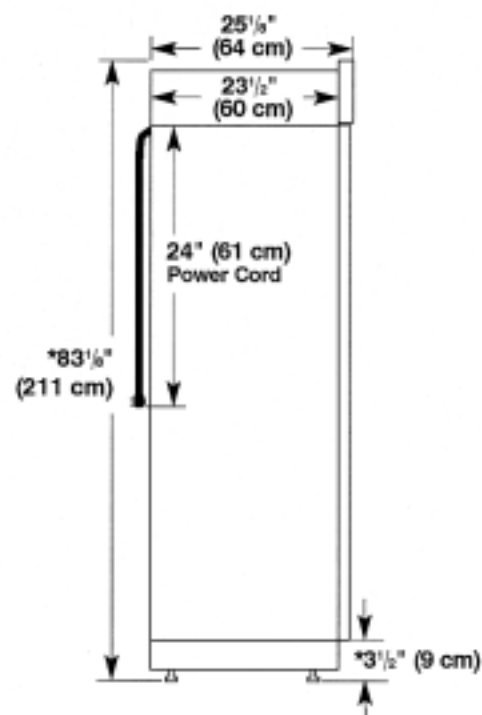

\*When leveling legs are fully extended to in. (32 mm) below rollers, add in. (29 mm) to the height dimensions.

#### Top View

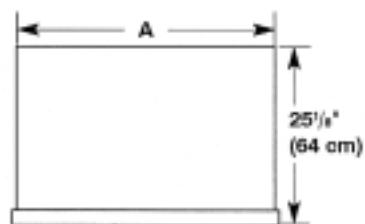

Model	Width A
42 in. (106 cm)	in. (104 cm)
48 in. (122 cm)	in. (119 cm)

#### Front View

Width dimensions were measured from trim edge to trim edge.

Height dimensions are shown with leveling legs extended in. (3 mm) below the rollers.

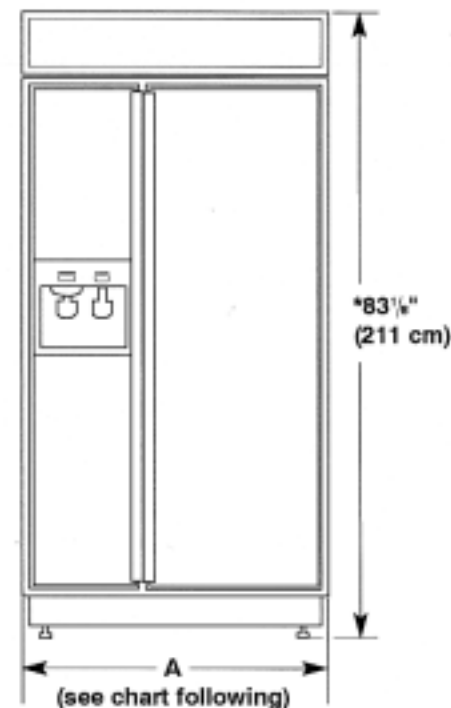

Model	Width A (Trim edge to trim edge)
42 in. (106 cm)	42 in. (107 cm)
48 in. (122 cm)	48 in. (123 cm)

\*When leveling legs are fully extended to in. (32 mm) below rollers, add in. (29 mm) to the height dimensions.

# Installation

## Tipping Radius

Be sure there is adequate ceiling height to stand the refrigerator upright when it is moved into place.

The dolly wheel height must be added to the tipping radius when a dolly is used.

If needed, the tipping radius can be reduced. See "Reduce Tipping Radius."

### Forward Tipping Radius

The forward tipping radius is the same for all models.

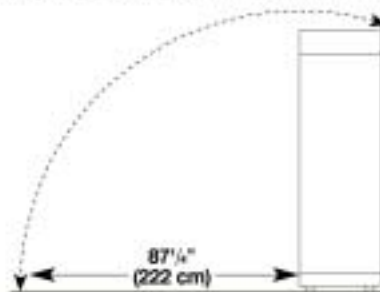

### Side Tipping Radius

The side tipping radius varies depending upon the width of the model. Use the chart provided to determine the side tipping radius.

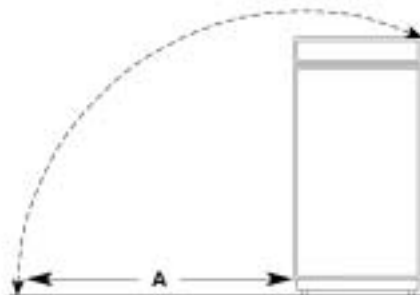

Model	Tipping Radius A
42 in. (106.7 cm)	93 in. (236.2 cm)
48 in. (121.9 cm)	96 in. (243.8 cm)

## Door Swing Dimensions

The location must permit both doors to open to a minimum of 90°. Allow 1/4 in. (11.4 cm) minimum space between the side of the refrigerator and a corner wall.

**NOTE:** More clearance may be required if you are using overlay panels or custom handles.

To adjust the door swing, see "Adjust Doors."

### 42 in. (106 cm) Models

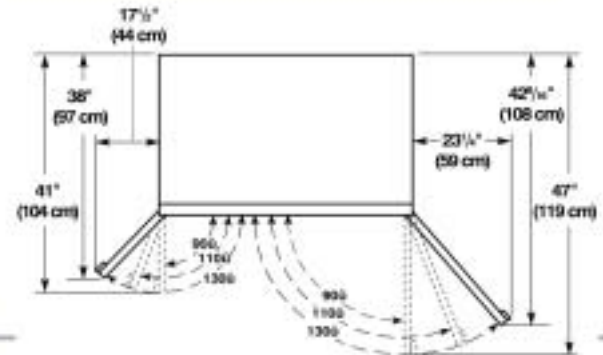

### 48 in. (122 cm) Models

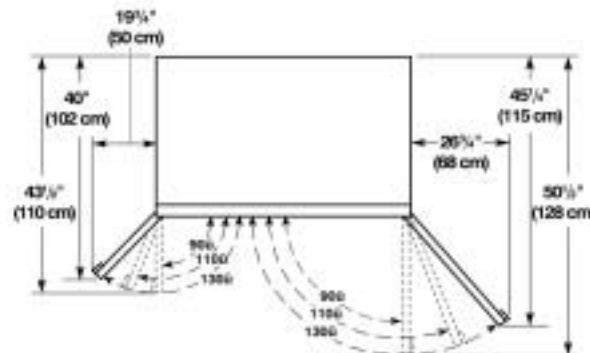

## Installation

### Reduce Tipping Radius (if required)

Before bringing the refrigerator into the home, be sure there is adequate ceiling height to stand the refrigerator upright. See "Tipping Radius" in the "Installation Requirements and Design Specifications" section for more information.

If you do not have adequate ceiling height to stand the refrigerator upright, the tipping radius can be reduced by removing the top grille and side trims (see the following chart).

Model	Reduced Tipping Radius
42 in. (106.7 cm)	88 in. (224.8 cm)
48 in. (121.9 cm)	89 in. (226.7 cm)

### Custom Panel Series

1. Grasp both ends of the top grille.
2. Push the top grille straight up, then pull straight out. Lay the grille on a soft surface.

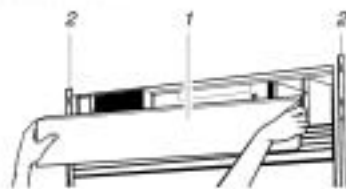

1. Top grille  
2. Cabinet side trim

3. Remove the 6 screws attaching each cabinet side trim to the refrigerator and remove the side trims.
4. Stand the refrigerator up. First, place the left bottom edge of the refrigerator on the floor, stand the refrigerator upright and then lower the right-hand side of the refrigerator to the floor.
5. Reassemble the trim and top grille after the dolly has been removed from the refrigerator.

### Curved Handle and Professional Handle Series

1. Grasp both ends of the lower panel. Push the lower panel straight up, then pull straight out. Lay the panel on a soft surface.
2. Grasp both ends of the top grille. Push the top grille straight up, then pull straight out. Lay the top grille on a soft surface.

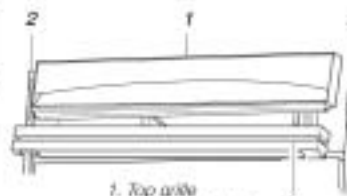

1. Top grille  
2. Cabinet side trim  
3. Lower panel

3. Remove the 6 screws attaching each cabinet side trim to the refrigerator and remove the side trims.
4. Stand the refrigerator up by first placing the left bottom edge of the refrigerator on the floor, standing the refrigerator upright and then lowering the right-hand side of the refrigerator down to the floor.
5. Reassemble the trim and top grille after the dolly has been removed from the refrigerator.

### Install Anti-Tip Boards

#### IMPORTANT:

The solid soffit must be within 1 in. (2.5 cm) maximum above the refrigerator. If the solid soffit is higher than 1 in. (2.5 cm) or one is not available, prevent the refrigerator from tipping during use as shown.

It is recommended that board(s) be installed before the refrigerator is installed.

Board(s) must be long enough to fully cover the width of the compressor cover.

Locate the board(s) so the bottom surface(s) of the board(s) is(are) 84 in. (213 cm) from the floor.

During installation, raise the refrigerator up so there is in. (8.35 mm) maximum between the top of the refrigerator and the bottom of the anti-tip board(s). Do not crush the condenser cover when raising the rear leveling legs.

#### To install anti-tip boards

1. Mark the stud locations on rear wall 80 in. to 90 in. (203 - 229 cm) above floor.
2. Securely attach one or two 2 in. x 4 in. x 32 in. (5 cm x 10 cm x 81 cm) wood boards to wall studs behind refrigerator. Use 6 - #8 x 3 in. (7.6 mm) (or longer) wood screws. The wood screws must be screwed into the studs at least 1/2 in. (3.8 cm). The board(s) must overlap the compressor cover.

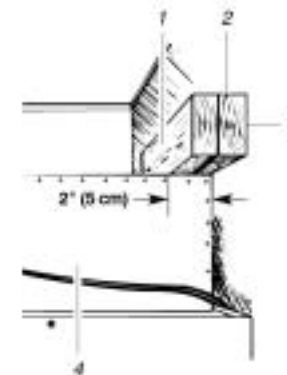

1. Center board in. (8.35 mm) max. above refrigerator  
2. Two 2 in. x 4 in. x 32 in. (5 cm x 10 cm x 81 cm) boards  
3. Attach to studs with 6 - #8 x 3 in. (7.6 cm) screws  
4. Compressor cover

## Component Access

**⚠ WARNING**



### **Tip Over Hazard**

**Refrigerator is top heavy and tips easily when not completely installed.**

**Keep door taped closed until refrigerator is completely installed.**

**Use two or more people to move and install refrigerator.**

**Failure to do so can result in death or serious injury.**



# Anti-Tip Boards

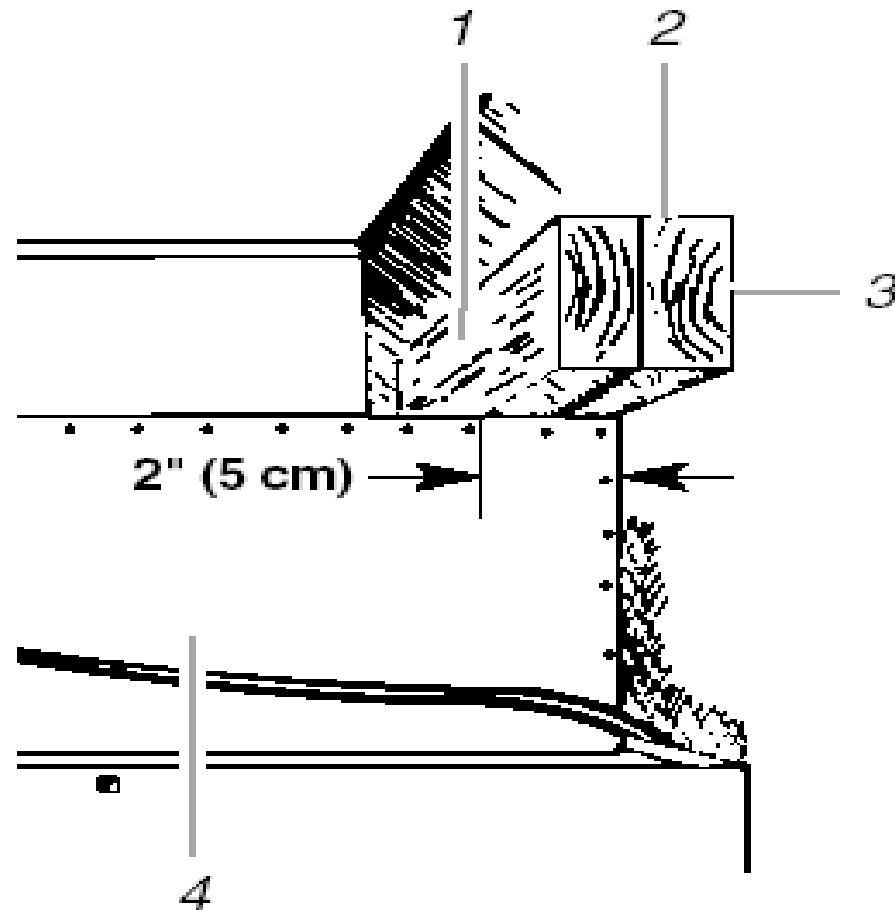

1. Center board  $\frac{1}{4}$  in. (6 mm) max. above refrigerator
2. Two 2 in. x 4 in. x 32 in. (5 cm x 10 cm x 81 cm) boards
3. Attach to studs with 6 -#8 x 3 in. (7.6 cm) screws
4. Compressor cover

# Installation

## Electrical Requirements

**⚠ WARNING**



**Electrical Shock Hazard**

**Plug into a grounded 3 prong outlet.**

**Do not remove ground prong.**

**Do not use an adapter.**

**Do not use an extension cord.**

**Failure to follow these instructions can result in death, fire, or electrical shock.**

Before you move your refrigerator into its final location, it is important to make sure you have the proper electrical connection:

## Water Supply Requirements

All installations must meet local plumbing code requirements.

The water shutoff should be located in the base cabinet on either side of the refrigerator or some other easily accessible area. The right-hand side is recommended. The access hole through the right-hand side cabinet must be within 6 in. (15.2 mm) of the rear wall.

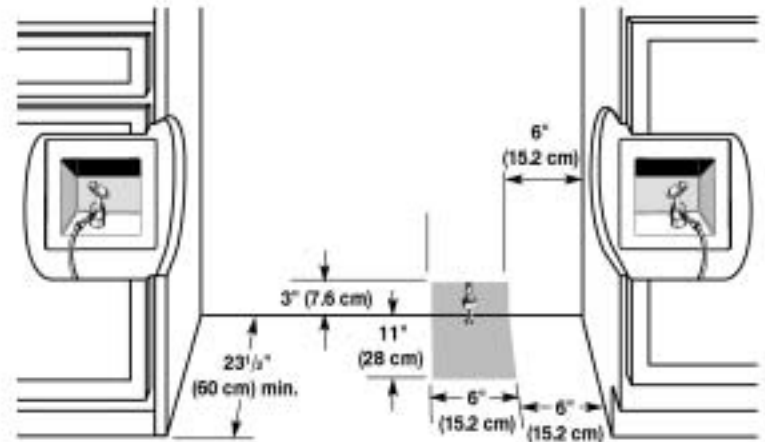

# Installation

## Electrical

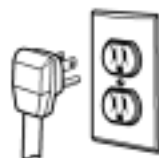

### Recommended grounding method

A 115 Volt, 60 Hz., AC only 15 or 20 ampere fused, grounded electrical supply is required. It is recommended that a separate circuit serving only your refrigerator be provided. Use an outlet that cannot be turned off by a switch. Do not use an extension cord.

**IMPORTANT:** If this product is connected to a GFCI (Ground Fault Circuit Interrupter) protected outlet, nuisance tripping of the power supply may occur, resulting in loss of cooling. Food quality and flavor may be affected. If nuisance tripping has occurred, and if the condition of the food appears poor, dispose of it.

**NOTE:** Before performing any type of installation, cleaning, or removing a light bulb, remove the top grille and turn the master power switch to OFF or disconnect power at the circuit breaker box.

When you are finished, turn ON the master power switch or reconnect power at the circuit breaker box. Then reset the control to the desired setting.

## Water

If the water shutoff valve is not in the cabinets, the plumbing for the water line can come through the floor or the back wall. A  $\frac{1}{2}$  in. (12.7 mm) hole for plumbing should be drilled 6 in. (15.2 cm) to 12 in. (30.4 cm) from the right-hand side cabinet or panel. On the floor, the hole should be no more than 11 in. (28 cm) away from the back wall. On the wall, the hole should be no more than 3 in. (7.6 cm) up from the floor. See "Connect Water Supply."

If this recommended water line location is used, no additional plumbing must be purchased.

If additional tubing is needed, use copper tubing and check for leaks. Install the copper tubing only in areas where the household temperatures will remain above freezing.

Do not use a piercing-type or  $\frac{1}{8}$  in. (4.76 mm) saddle valve which reduces water flow and clogs more easily.

**NOTE:** Your refrigerator dealer has a kit available with a  $\frac{1}{2}$  in. (6.35 mm) saddle-type shutoff valve, a union, and copper tubing. Before purchasing, make sure a saddle-type valve complies with your local plumbing codes.

### Cold water supply

Connect the ice maker to a cold water line with water pressure between 15 and 100 psi (103 - 690 kPa). If you have questions about your water pressure, call your utility company.

# Installation

## Connect Water Supply

1. Remove the shipping tape from the gray, coiled water tubing on the rear of the refrigerator.
2. Before attaching copper tubing to the refrigerator, flush at least 2 qt. (1.9 L) of water through the copper tubing and into a bucket to get rid of any particles in the water line.
3. Check for leaks around the saddle valve. Do not overtighten the clamp or sleeve. This will crush the copper tubing.
4. Make connection to the refrigerator.

### Style 1 - Connecting to a Water Valve:

**NOTE:** The water shutoff valve should be located in the base cabinet on either side of the refrigerator. The right-hand side is recommended. The access hole through the right cabinet must be within ½ in (12.7 mm) of rear wall.

Push the bulb end of the tubing into the water valve as far as it will go. Slide the nut forward and finger tighten. Then tighten it with a wrench two more turns. Do not overtighten.

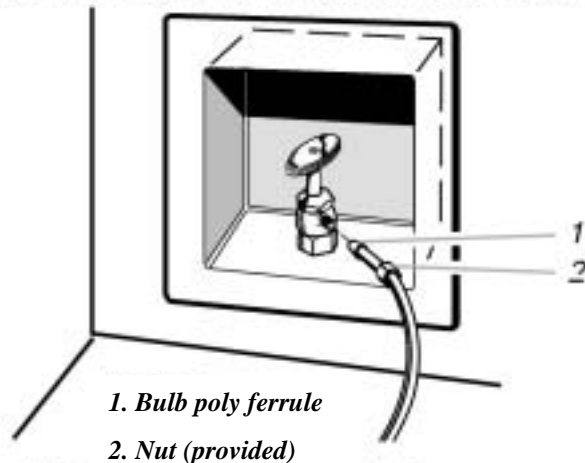

### Style 2 - Connecting to a Water Line

Additional Parts Needed: Coupling, ferrule and nut.

Slide the purchased nut then the purchased ferrule onto the tubing. Push the tubing into the purchased coupling as far as it will go. Slide the nut and ferrule forward. Tighten the nut by hand. Then tighten it with a wrench two more turns. Do not overtighten.

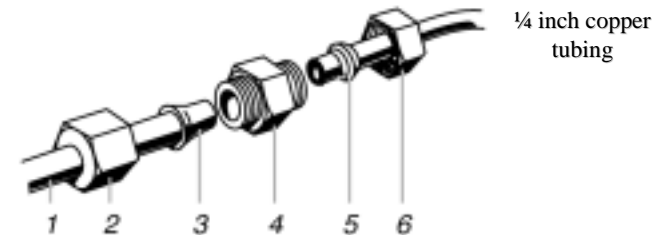

1. Line to refrigerator
  2. Nut (provided)
  3. Bulb poly ferrule
  4. Coupling (purchased)
  5. Ferrule (purchased) Brass
  6. Nut (purchased)
5. Turn shutoff valve ON.
  6. Check for leaks. Tighten any nuts or connections (including connections at the valve) that leak.

## LEVELING THE REFRIGERATOR

**NOTE:** Door panels must be installed before leveling.

1. Open the doors and place a level on top of the refrigerator frame. Check to see if the refrigerator is level from left to right.

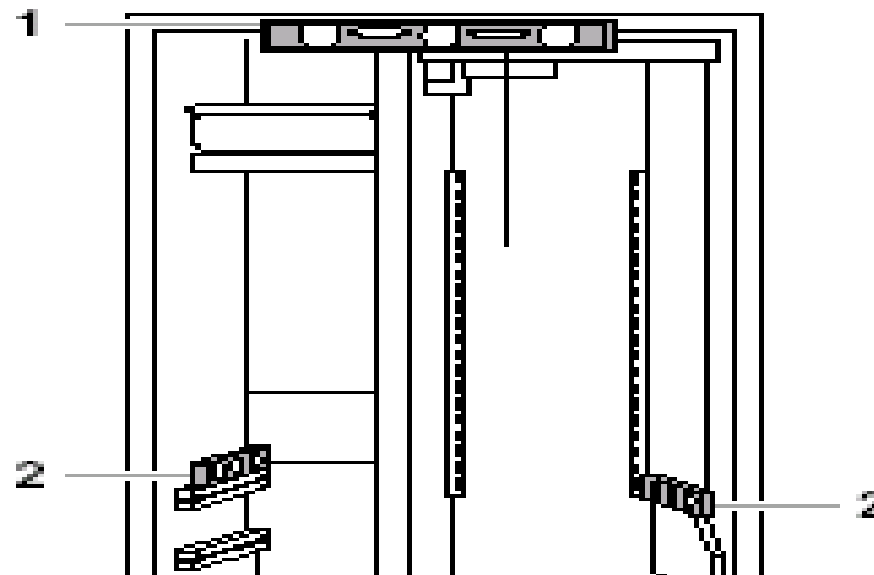

- 1. Level to check left to right leveling*
- 2. Level to check front to back leveling*

# Installation

## Plug in Refrigerator

**⚠ WARNING**



**Electrical Shock Hazard**  
**Plug into a grounded 3 prong outlet.**  
**Do not remove ground prong.**  
**Do not use an adapter.**  
**Do not use an extension cord.**  
**Failure to follow these instructions can result in death, fire, or electrical shock.**

1. Set control switch at top of cabinet to the OFF position.
2. Plug into a grounded 3 prong outlet.

## Move Refrigerator to Final Position

**IMPORTANT:** To prevent floor damage, make sure levelers are raised (not touching floor) and refrigerator is on rollers before moving.

1. Place top of cardboard carton or plywood under refrigerator. Remove dolly.
2. Do not remove protective film.
3. Move the refrigerator straight back and evenly into the opening. Check to make sure that water tubing is not kinked and the power supply cord is on top of the refrigerator next to the cover.

## Lower Leveling Legs

**NOTE:** All 4 leveling legs must contact the floor to support and stabilize the full weight of refrigerator. Rollers are for moving refrigerator and not for permanent support.

Use socket wrench to turn leg levelers on both sides of refrigerator to the right (clockwise) until refrigerator weight is supported by leveling legs. The rollers should be off the floor. To avoid cabinet damage, do not apply more than 50 in. - lbs. (58 cm - kg) of torque to the leveling legs.

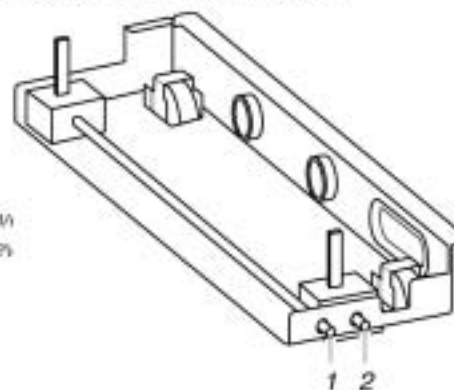

1. Rear leg
2. Front leg

## Lower Leveling Legs

**NOTE:** All 4 leveling legs must contact the floor to support and stabilize the full weight of refrigerator. Rollers are for moving refrigerator and not for permanent support.

Use socket wrench to turn leg levelers on both sides of refrigerator to the right (clockwise) until refrigerator weight is supported by leveling legs. The rollers should be off the floor. To avoid cabinet damage, do not apply more than 50 in. - lbs. (58 cm - kg) of torque to the leveling legs.

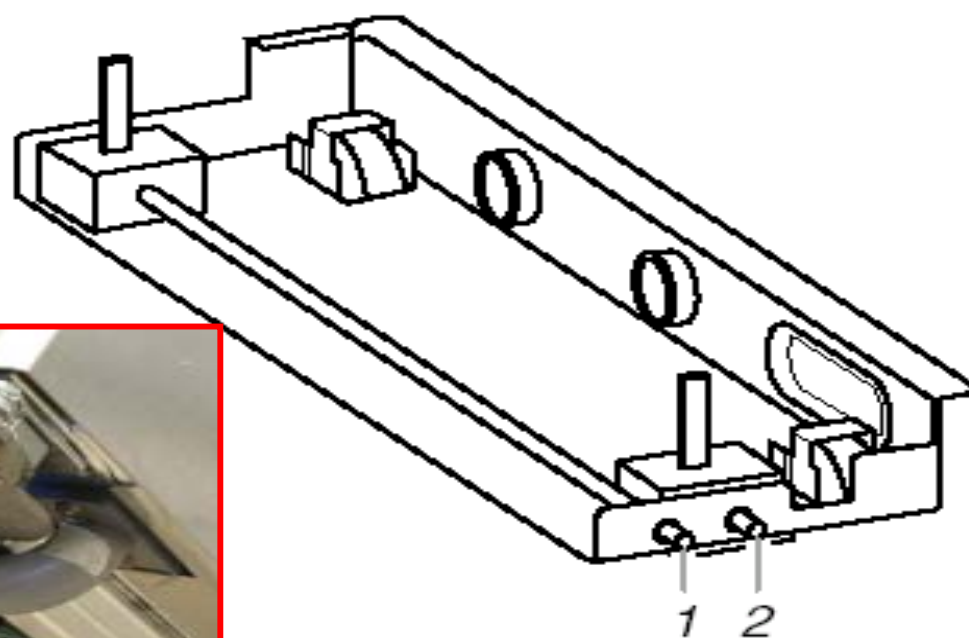

1. Rear leveling legs
2. Front leveling legs

## Classic and Architect® Models

Remove the door stop screw from the bottom side of the hinge.

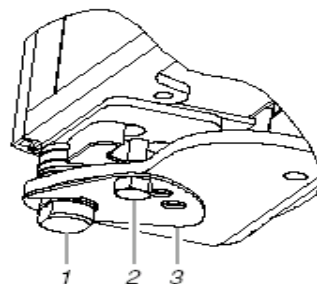

1. Bushing
2. Door stop screw
3. locking plate

## Overlay Models

Remove the 2 door stop screws: one from the bottom side using a  $\frac{3}{8}$  in. open end wrench and one from the top side using an Allen wrench.

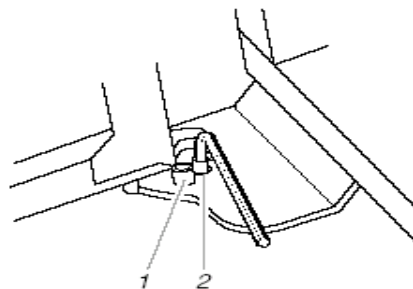

1. Door stop screw from bottom
2. Door stop screw from top

2. Remove the locking plate as shown.

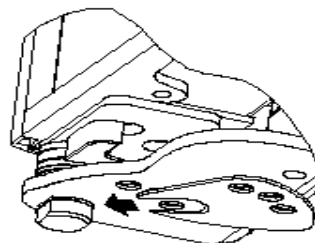

3. Turn the bushing located underneath the bottom of the hinge using the open-end wrench. Turning the bushing to the left (counterclockwise) will raise the door. Turning the bushing right (clockwise) will lower the door.



## Door Swing Adjustment

1. Check that the refrigerator door can open freely. If the door opens too wide, remove the door stop screw or screws (depending on your model) from the bottom hinge. See "Door Height Adjustment" earlier in this section.
2. Hold the door open to a position that is less than 90°.
3. Replace the door stop screw or screws in the bottom hinge and tighten.

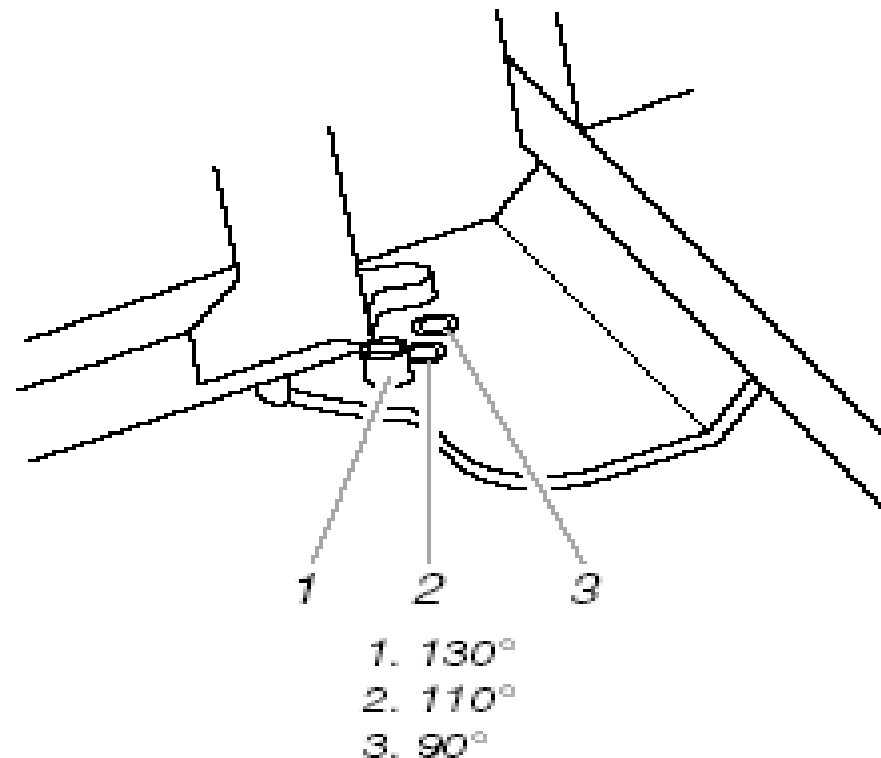

## ADJUSTING THE DOORS

### Door Alignment

Use the following steps to adjust the door alignment to the left, right, in, or out.

1. Inspect the spacing of the gap between the freezer and refrigerator doors. Make sure that the spacing between the doors is the same distance at the top and bottom.

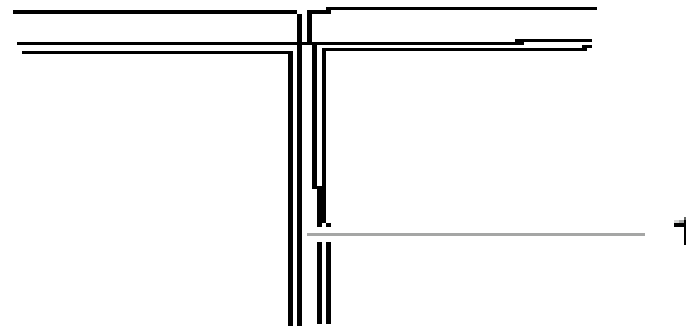

*1. Uneven door gap*

2. If the door gap is uneven, the side trim must be removed so that you can see the entire door gasket liner. Remove the six phillips screws holding the side trim.

# Right to Left Door Alignment



**Tap plate  
screws**

**T27  
Torx™**



# Vertical Door Adjusting & Refrigerator Leveling Legs

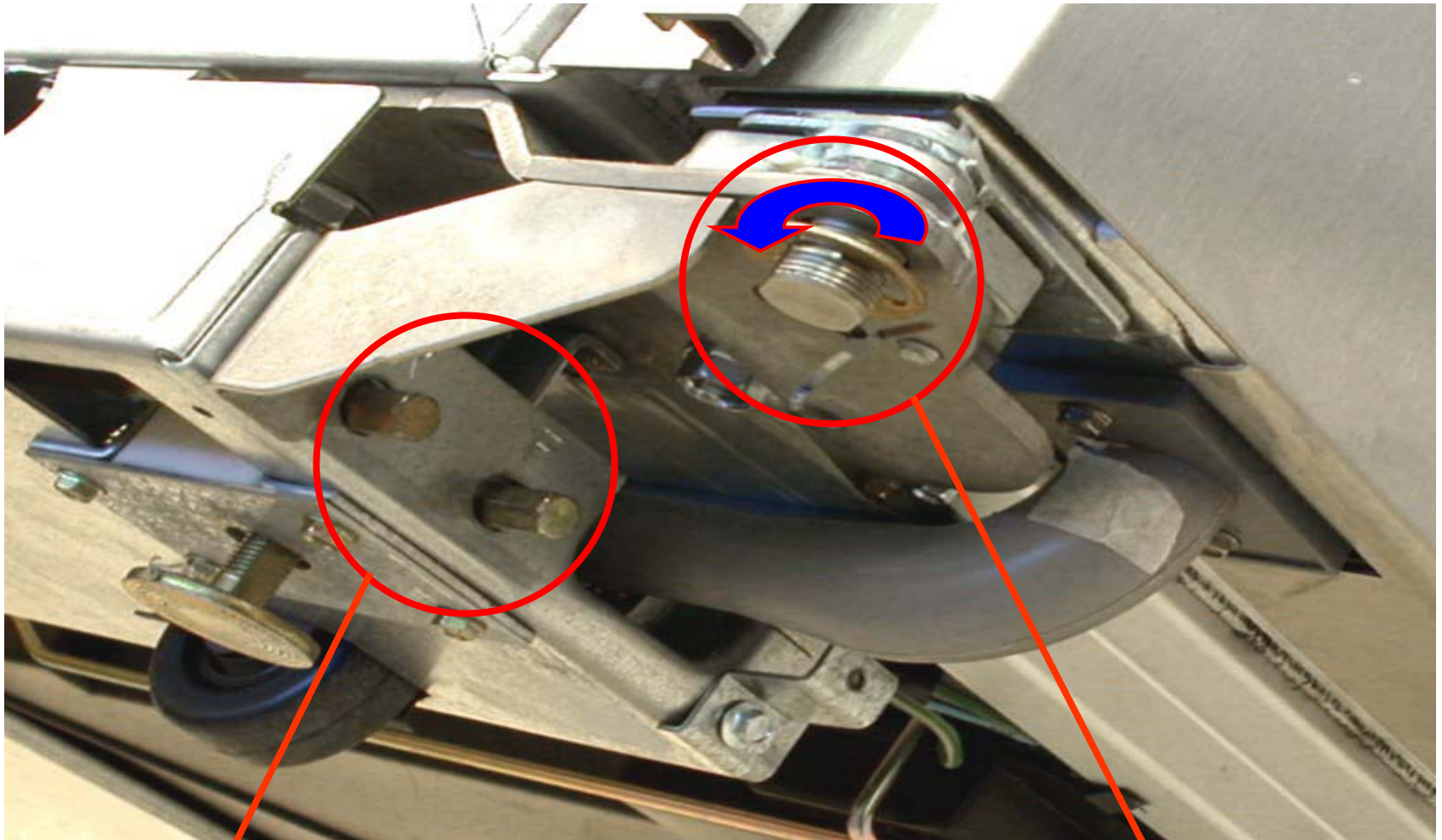

**Leveling legs  
adjusters**

**Counter clockwise will  
raise the door**



# BIR Refrigerator Theory...Electronic Control

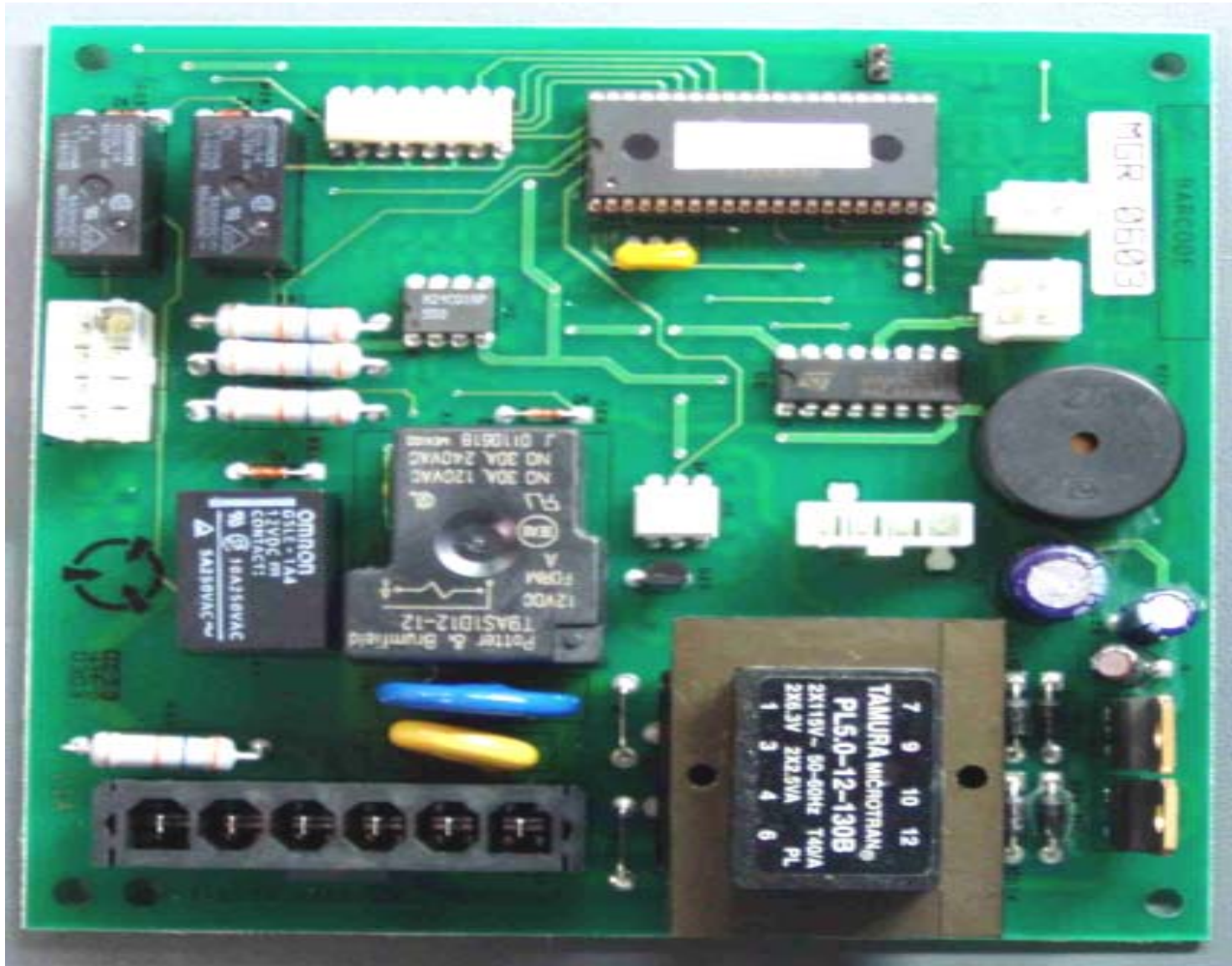

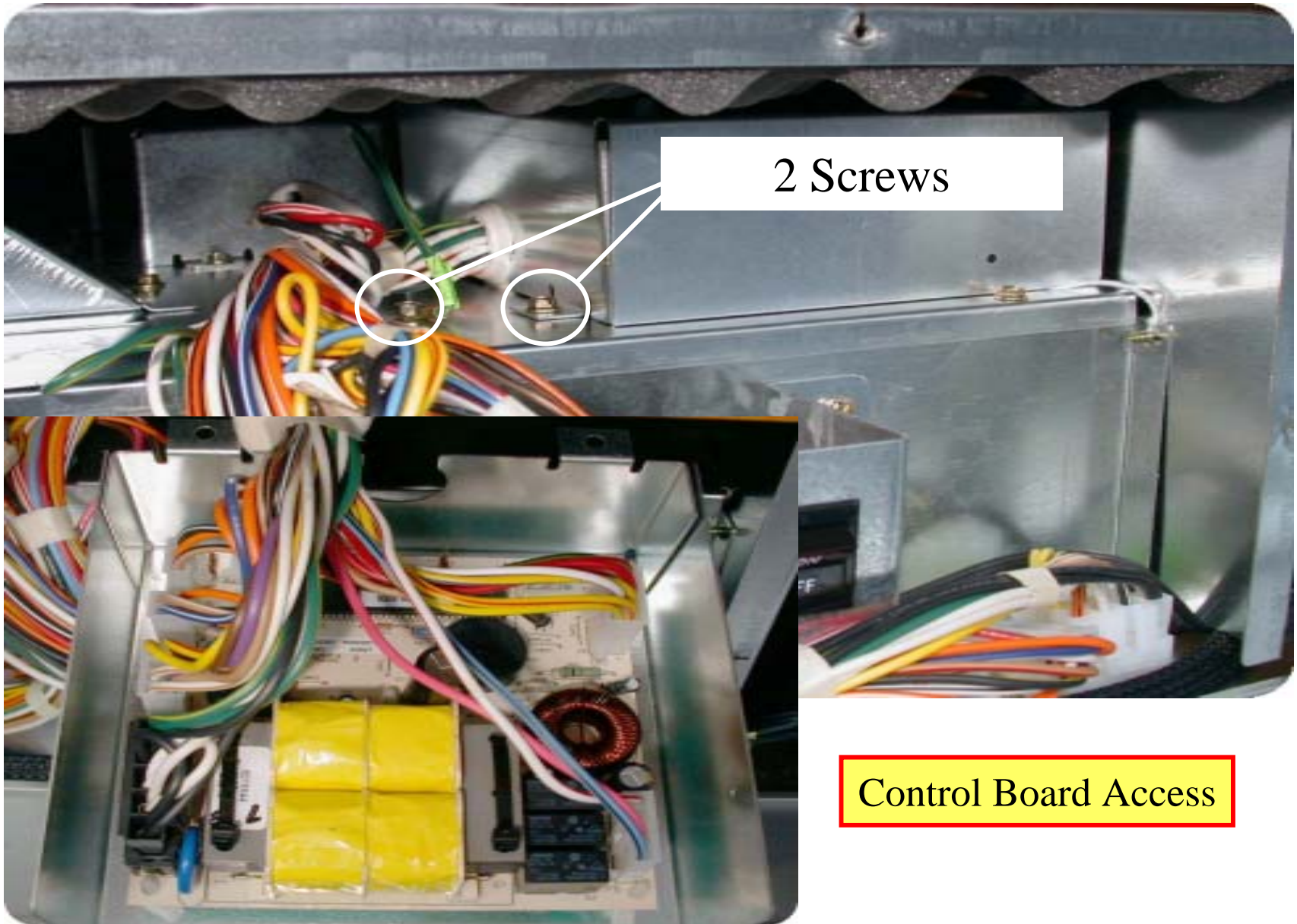

2 Screws

Control Board Access



# Component Testing

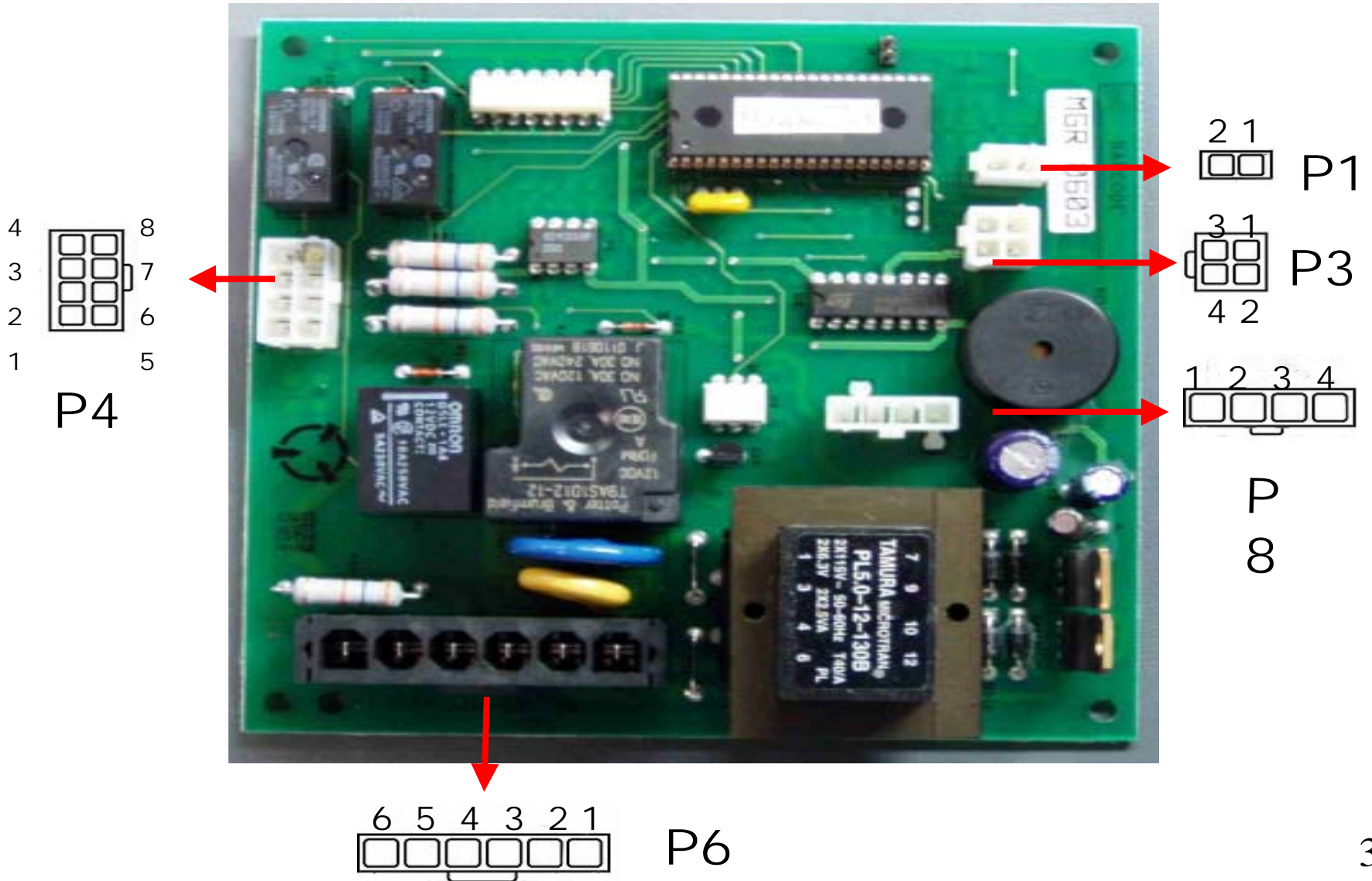

<b>Plug Number</b>	<b>Pin Number</b>	<b>Description</b>
<b>P1</b> 2-pin	1	RC Thermistor, (BU/WH)
	2	FC Thermistor, (TN/WH)
<b>P3</b> 4-pin	1	Display signal, TN/BK)
	2	12VDC, (OR)
	3	GND for thermistors, OR/BK)
	4	GND, BK/WH)
<b>P4</b> 8-pin	1	Disp. Water valve input, (V)
	2	Ice maker water valve input, (TN)
	3	RC door switch input, (Y)
	4	FC door switch input, (YL/RD)
	5	IM fill tube heater, (BK/WH)
	6	
	7	FC door output, (WH/TN)
	8	RC door output, (WH/TN)
<b>P6</b> 6-pin	1	AC, L1, (BK)
	2	AC, Neutral, (WH)
	3	Compressor output, (WH/RD)
	4	Bimetal input, (BR)
	5	Evaporator fan output, (YL/BK)
	6	Defrost heater output, (PK)
<b>P8</b> 4-pin	1	Air door
	2	Air door
	3	Air door
	4	Air door



# Manufacturing Mode

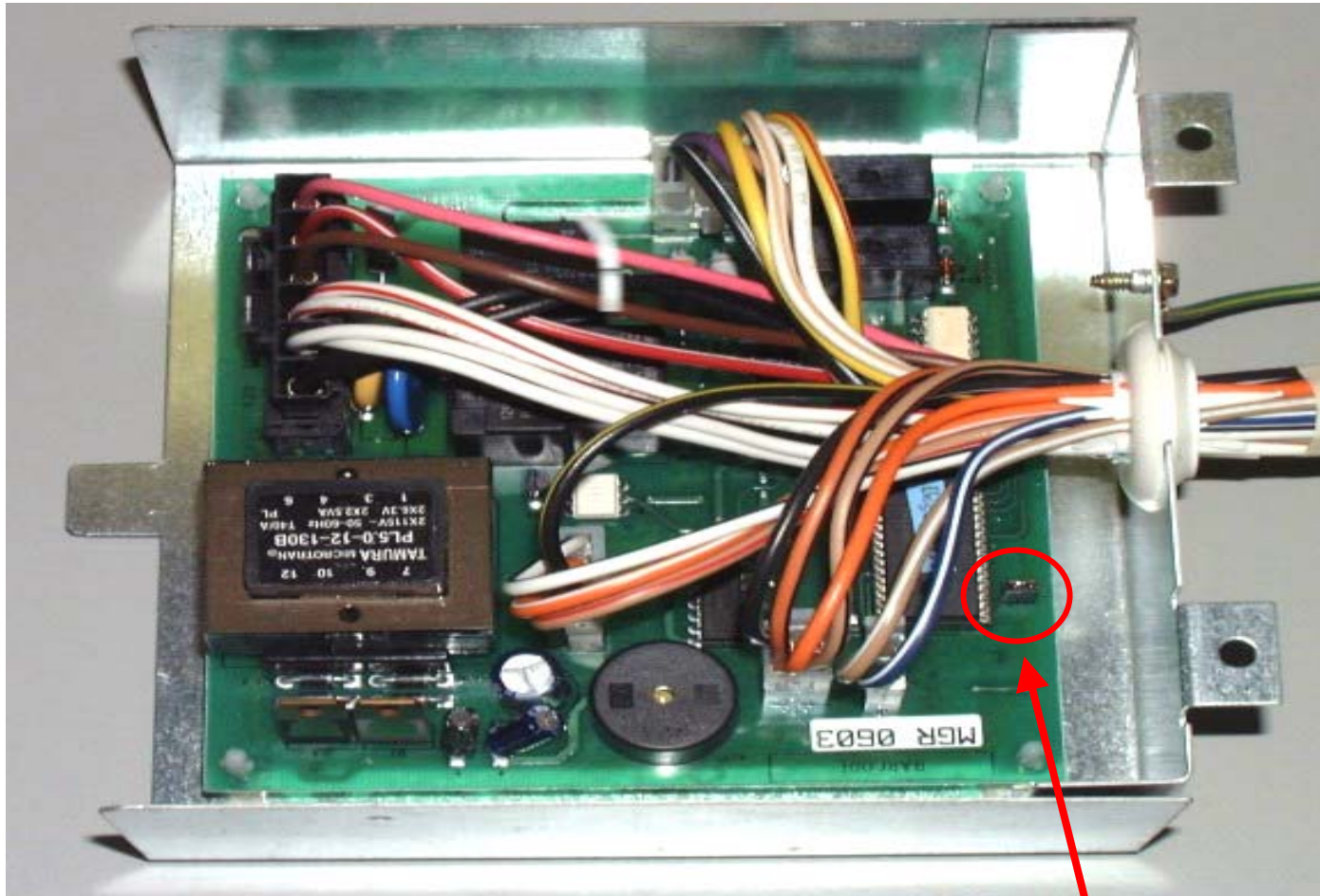

If jumper is left on board it will cause the display to go into the test mode when unit is powered up. Lasts approx. 20 seconds on power-up. Refrigerator then operates normally

**Jumper**

# Display and Keypad



- 1. Refrigerator temperature setting from 46 to 34F and displays 70 to 27F**
- 2. Freezer temperature setting from 6 to -5F and displays 70 to -5F**

**Displays set temperature when actual temperature is within 6 degrees of setting**

- 3. Water Filter % status, (400 gallons)**

**Holiday mode will disable;**

- Interior lights**
- All display LEDs except Holiday Mode LED**
- Keypad operation except Holiday Mode & On / Off manually disable the ice maker**

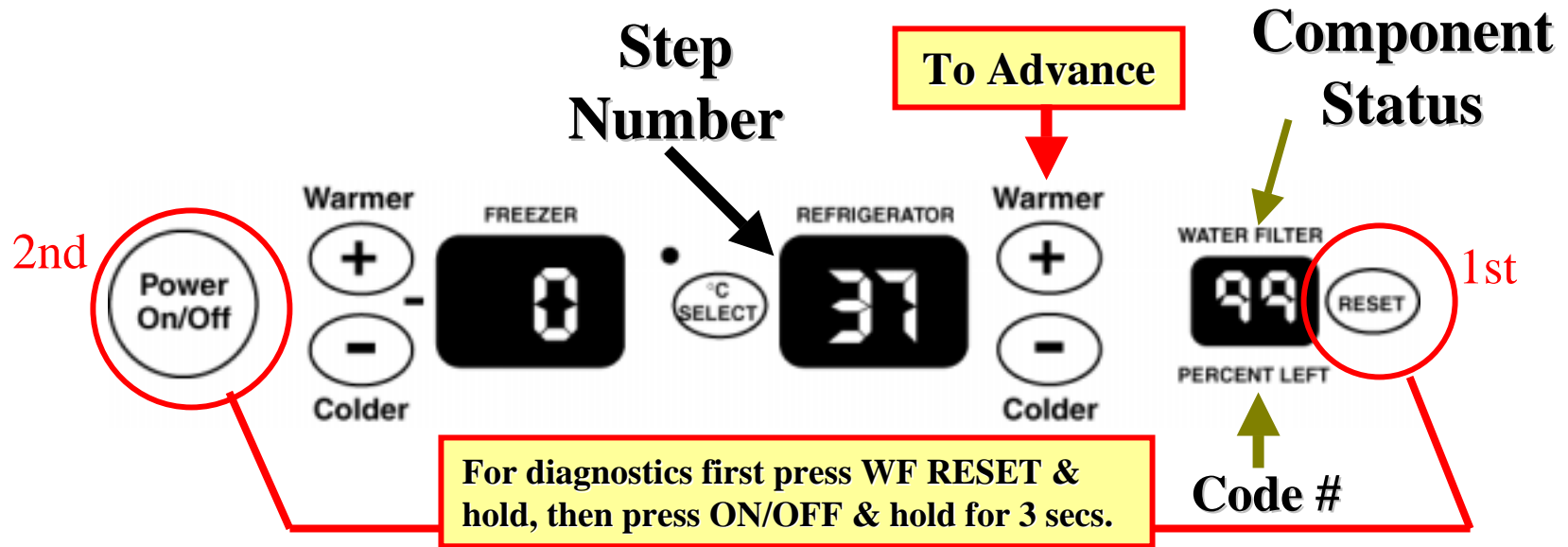

Component	Step #	Code #	Code Description
Bimetal & defrost heater	1	2	Bimetal closed/heater energized
		1	Bimetal open/heater not energized
FC thermistor	2	1	Thermistor within operating region
		2	Thermistor within open region
		3	Thermistor within shorted region
RC thermistor	3	1	Thermistor within operating region
		2	Thermistor within open region
		3	Thermistor within shorted region
Air door	4	1	Air door closes then opens fully
Evaporator fan motor	5	1	Evaporator fan motor operates

**20 minute time out for service diagnostics**

# Adaptive / Pulsed Defrost



- 8 to 100+ hours between defrosts. Set by how long it takes to open the Defrost Limiter
- Heat is on for the first 2 minutes
- Heat then cycles off 1 minute & on 2 minutes.

Maximum Defrost time  
30 Minutes

## Delay Times, (after defrost):

- Compressor (Drip time) = 4 minutes
- Evaporator fan, 8 minutes
- Air door, 8 minutes. Air door will close when in defrost.

Diagnostics  
Step 1

# Door Switch & Spring

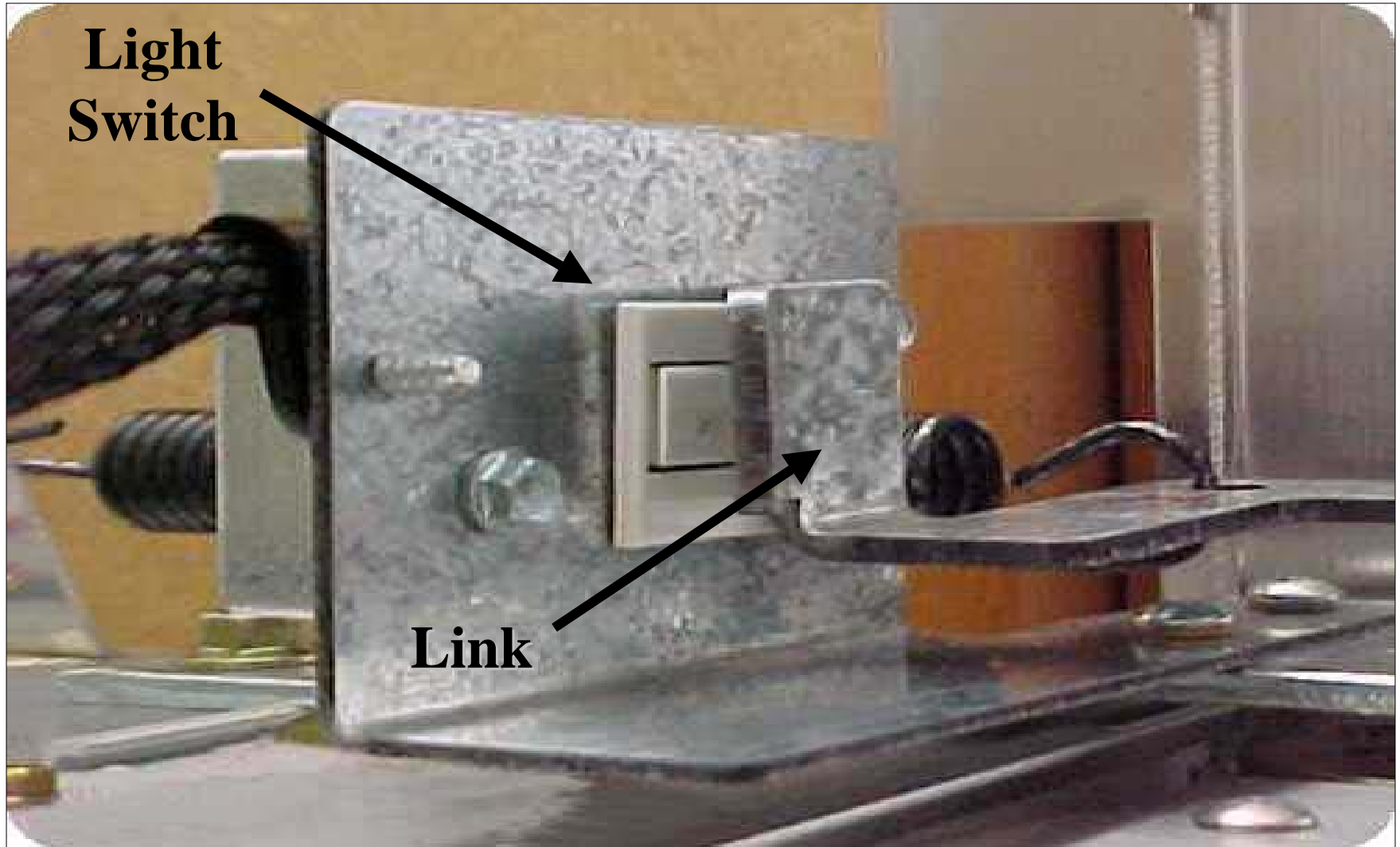



# Motorized Air Baffle

**12 VDC  
Stepper  
Motor**

**Can not  
check for  
12VDC**

**To check,  
has to be put  
into  
diagnostics**

**Step 4  
Code 1**

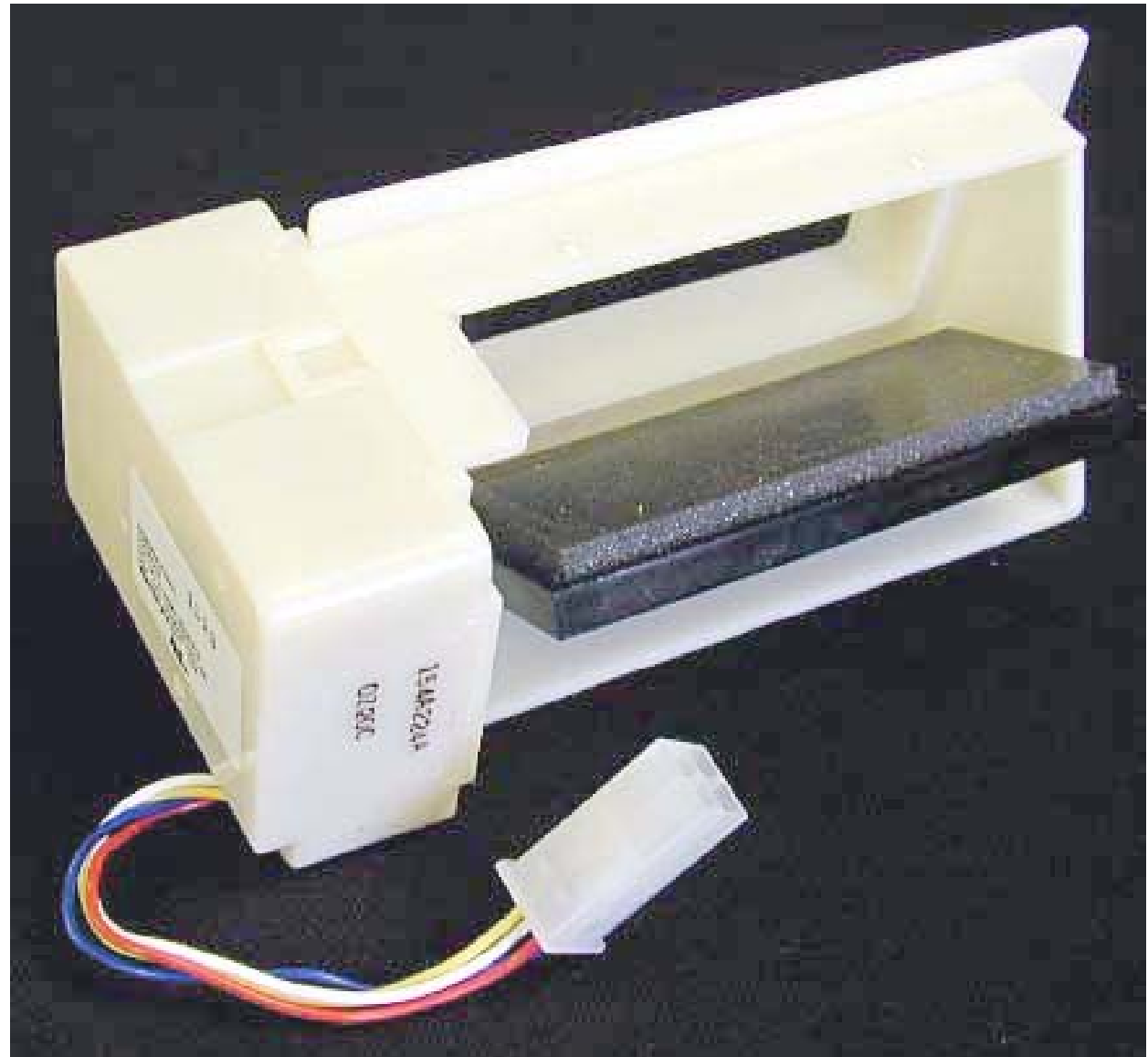

# Air Door Access / Removal

**Step 1**



**Step 2**

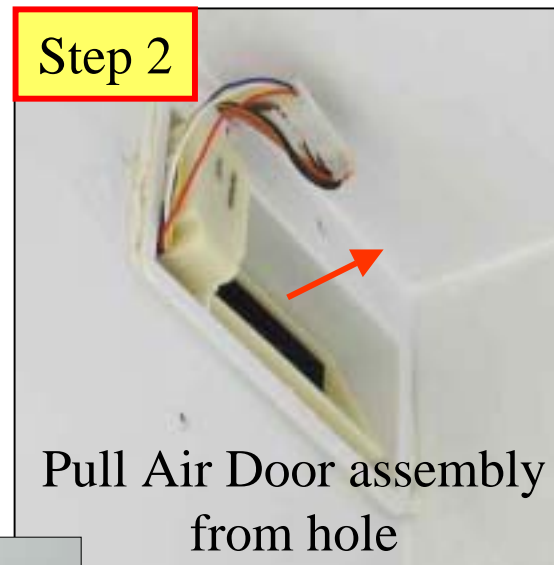

**Step 3**



Disconnect plug from harness

**Diagnostics**  
Step 4  
Code 1

# Evaporator Fan Motor

Diagnostics  
Step 5  
Code 1

Step 1

Remove the Evaporator Cover  
to access Fan & Motor

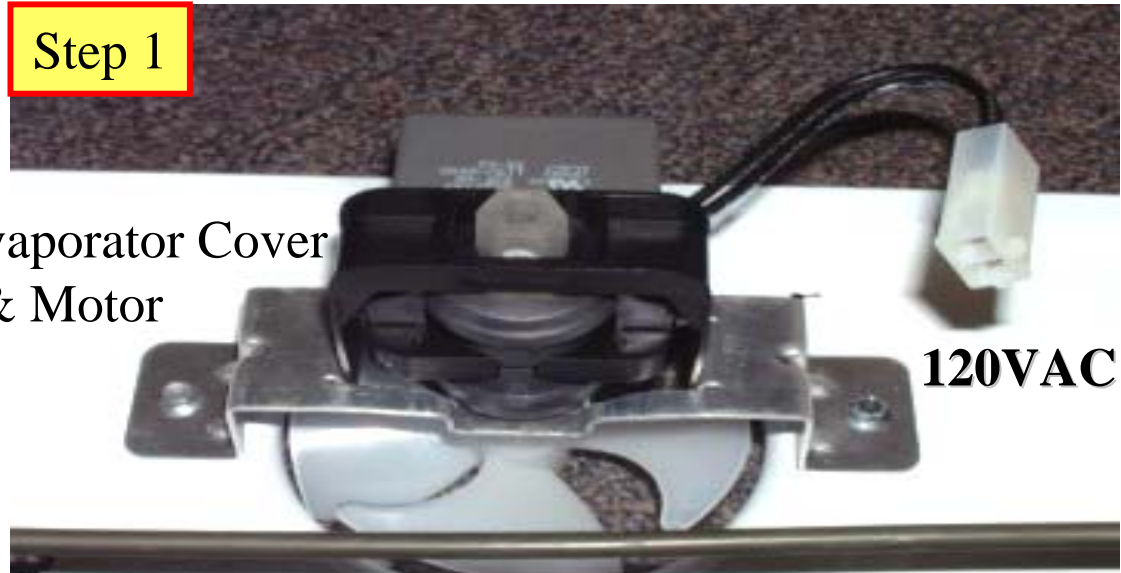

Step 2



Squeeze rear motor bracket to  
release it from the front bracket

Step 3



Remove bracket and pull fan blade  
off the shaft to remove motor



# Thermistors 8750 ohms @ 32F

## Diagnostics

Freezer Step 2

Refrigerator Step 3



## How to Test at 32F

Fill a container with ice

Add water just until the ice begins to float.

Place the Thermister in the middle of the ice & water.

Wait 10 minutes for ice, water, & the Thermister to chill to approximately 32 degrees and check resistance

**Thermistor defaults :** ( 140F or – 40F )

- Refrigerator - the air door cycles open 10 min / closed 10 minutes
- Freezer – the compressor runs 10 minutes and off 10 minutes

## Main control board block diagram

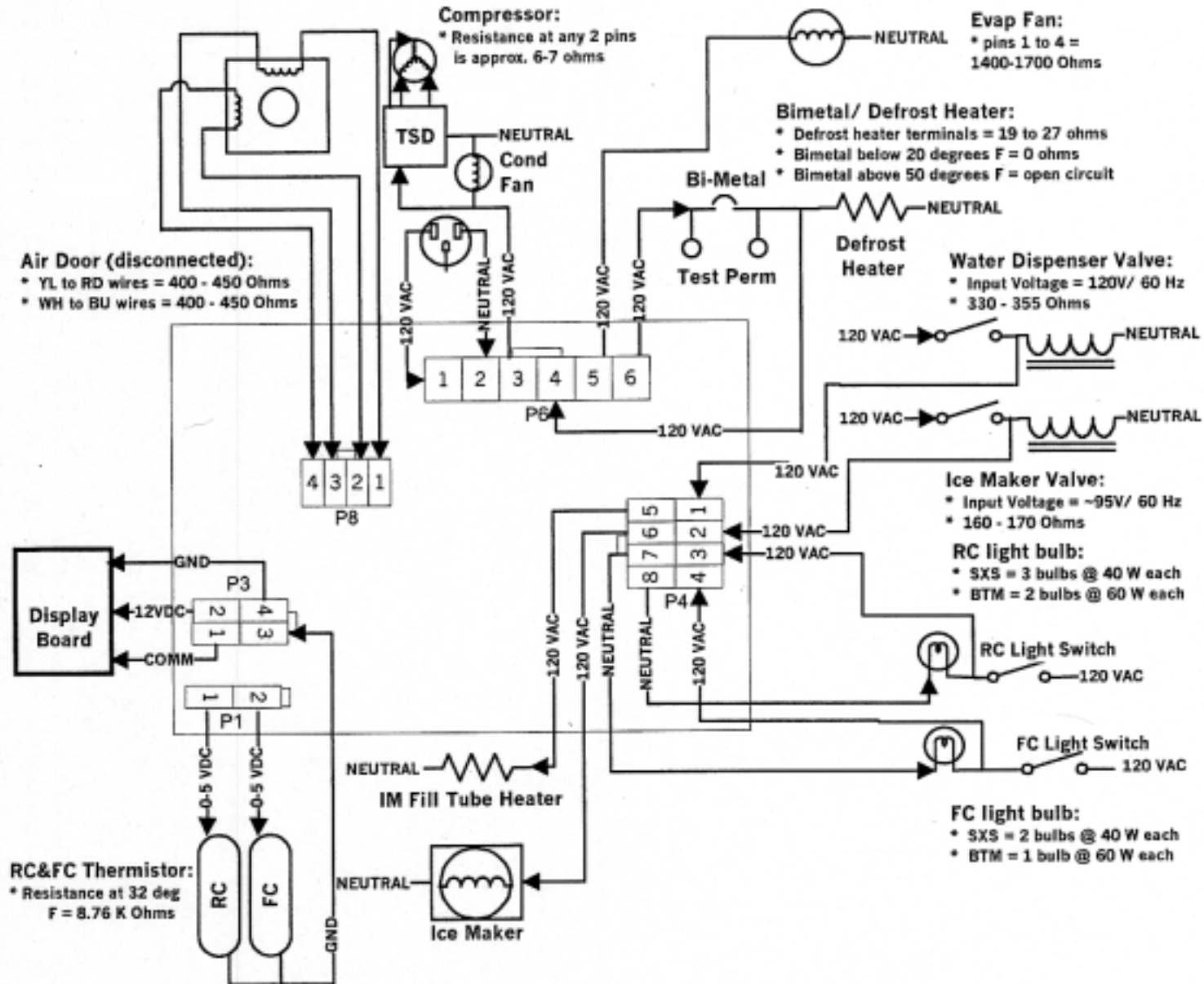

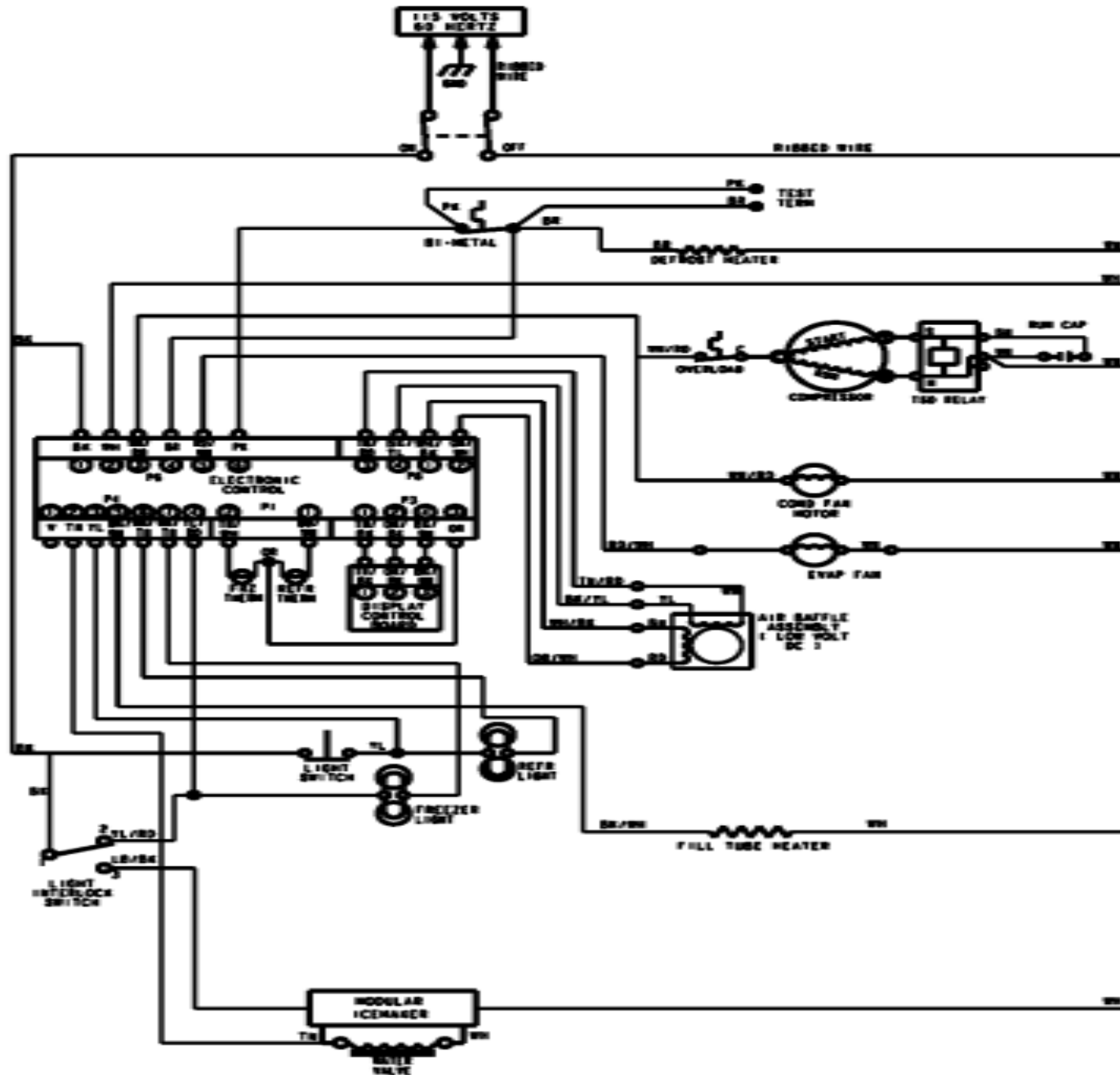

# TSD Relay ( Time Start Device )

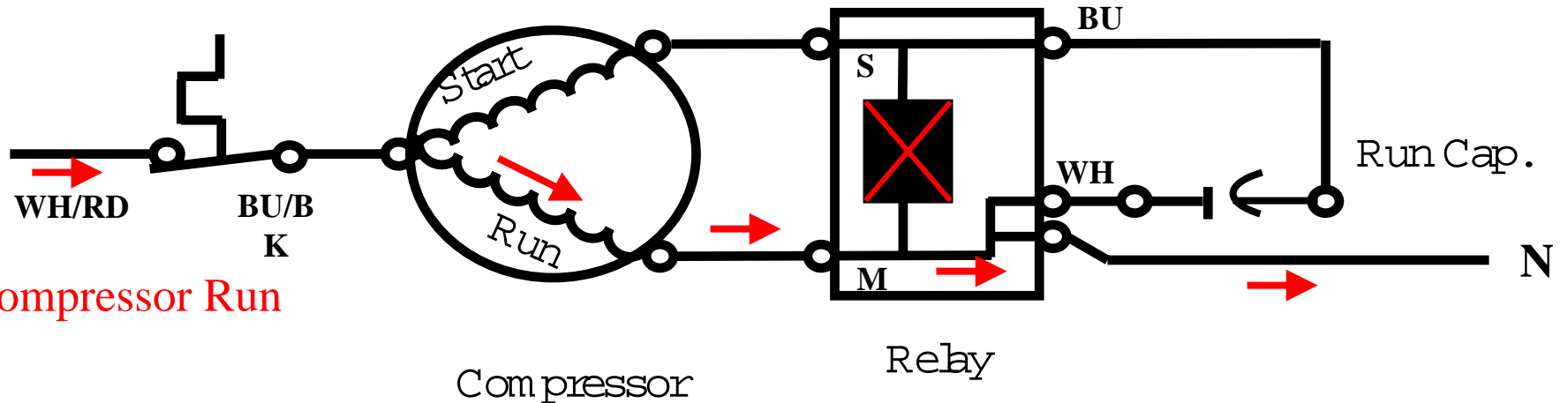
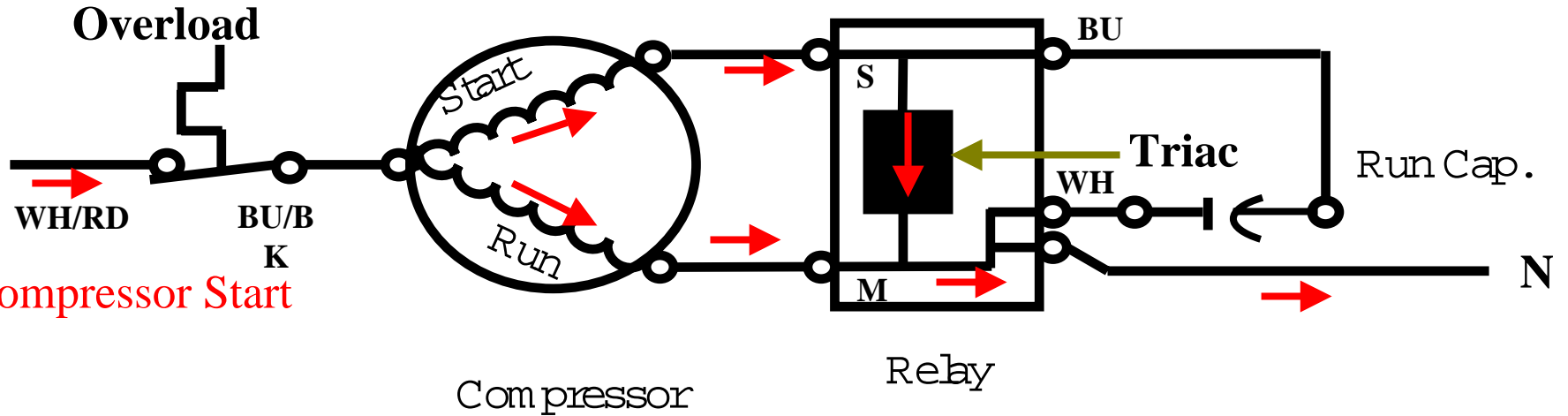

# Condenser Access



# Cover Removed

**To be introduced on  
later Thermador units**



**To be introduced on  
later Thermador units**

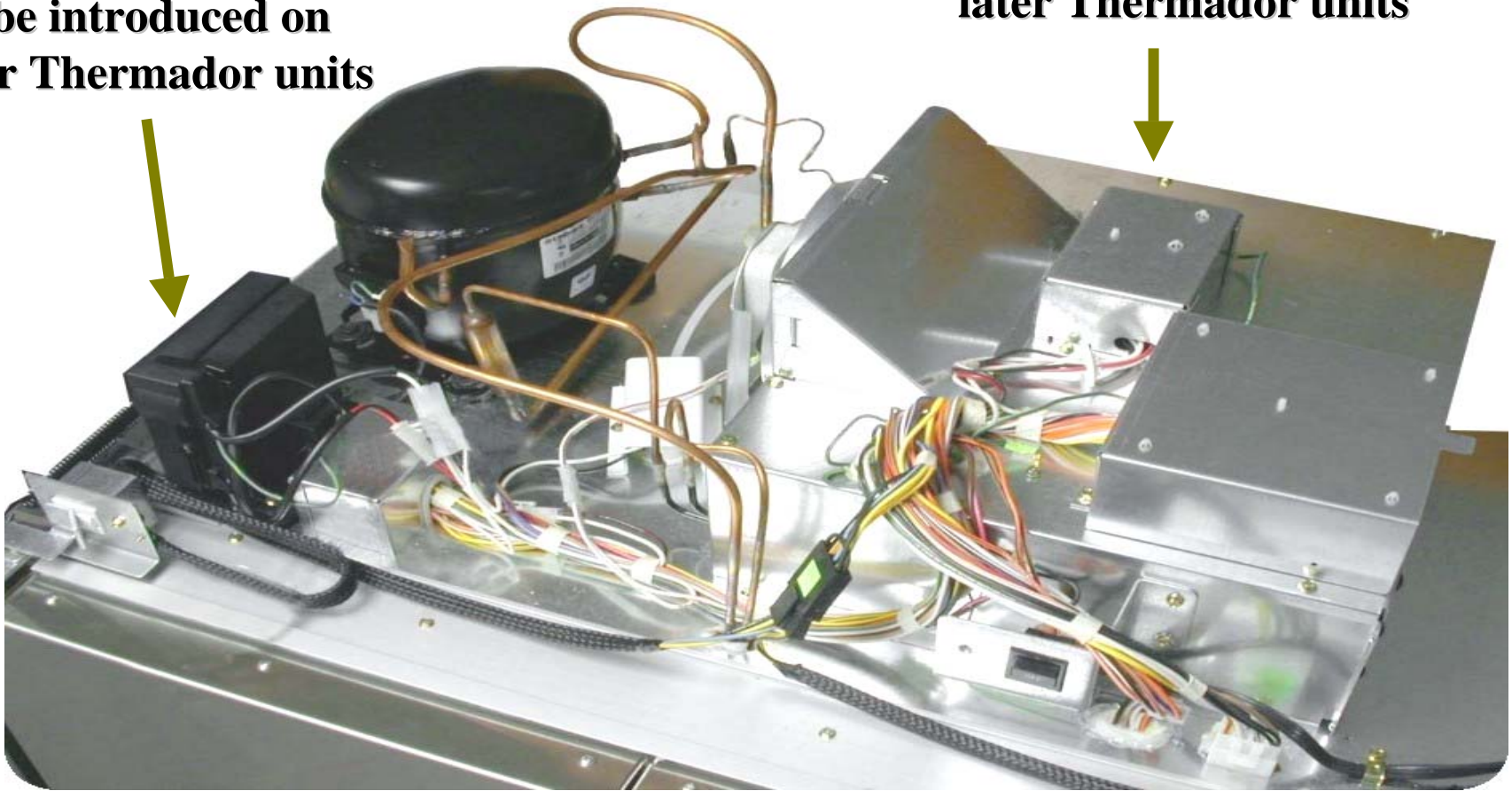



# Condenser Fan Motor

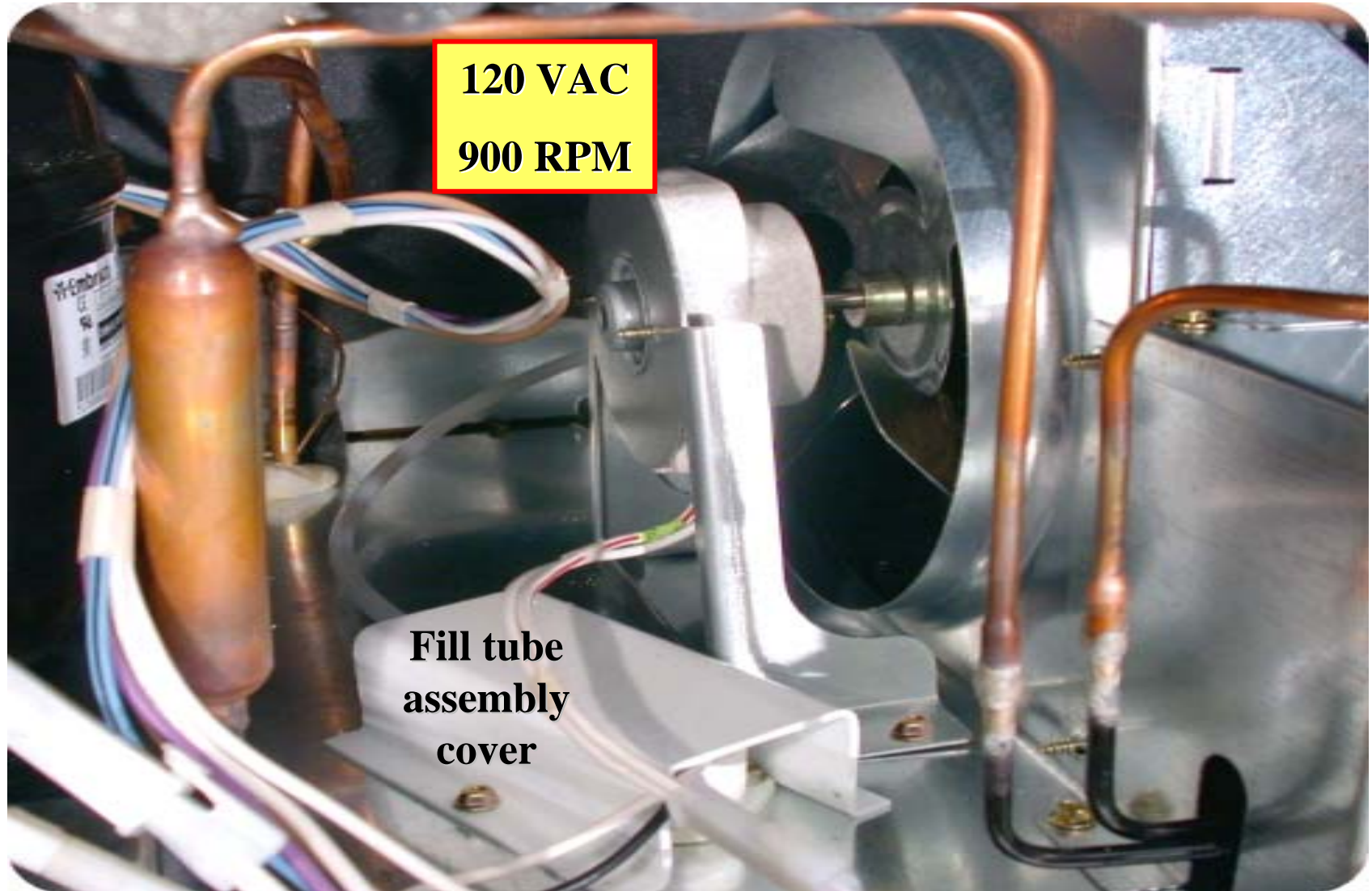

**120 VAC**

**900 RPM**

**Fill tube  
assembly  
cover**

# Sealed System Schematic

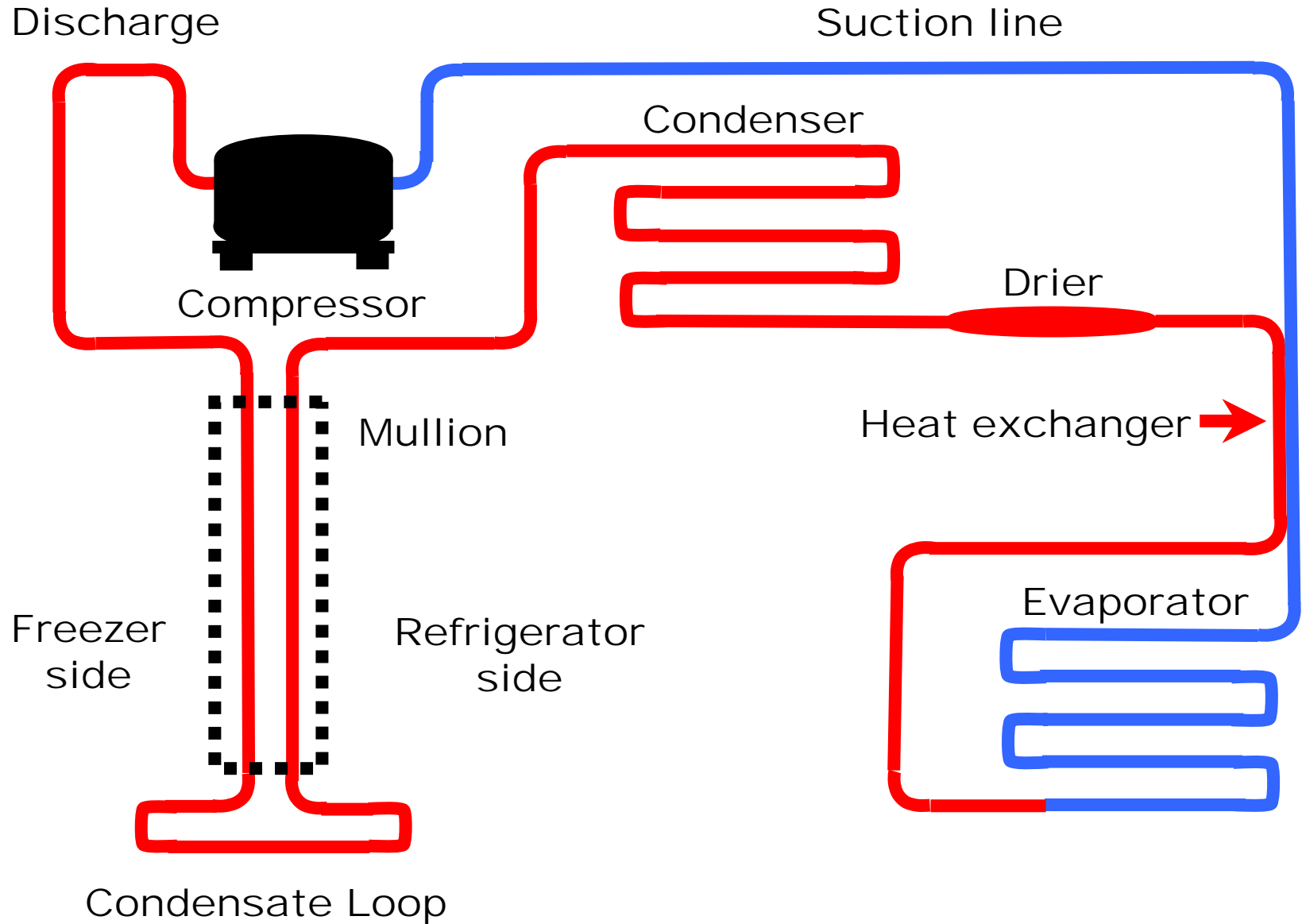



# Replacement Heat Exchangers



**Planned for by year end 2003 or early 2004**

# Sealed System Joints

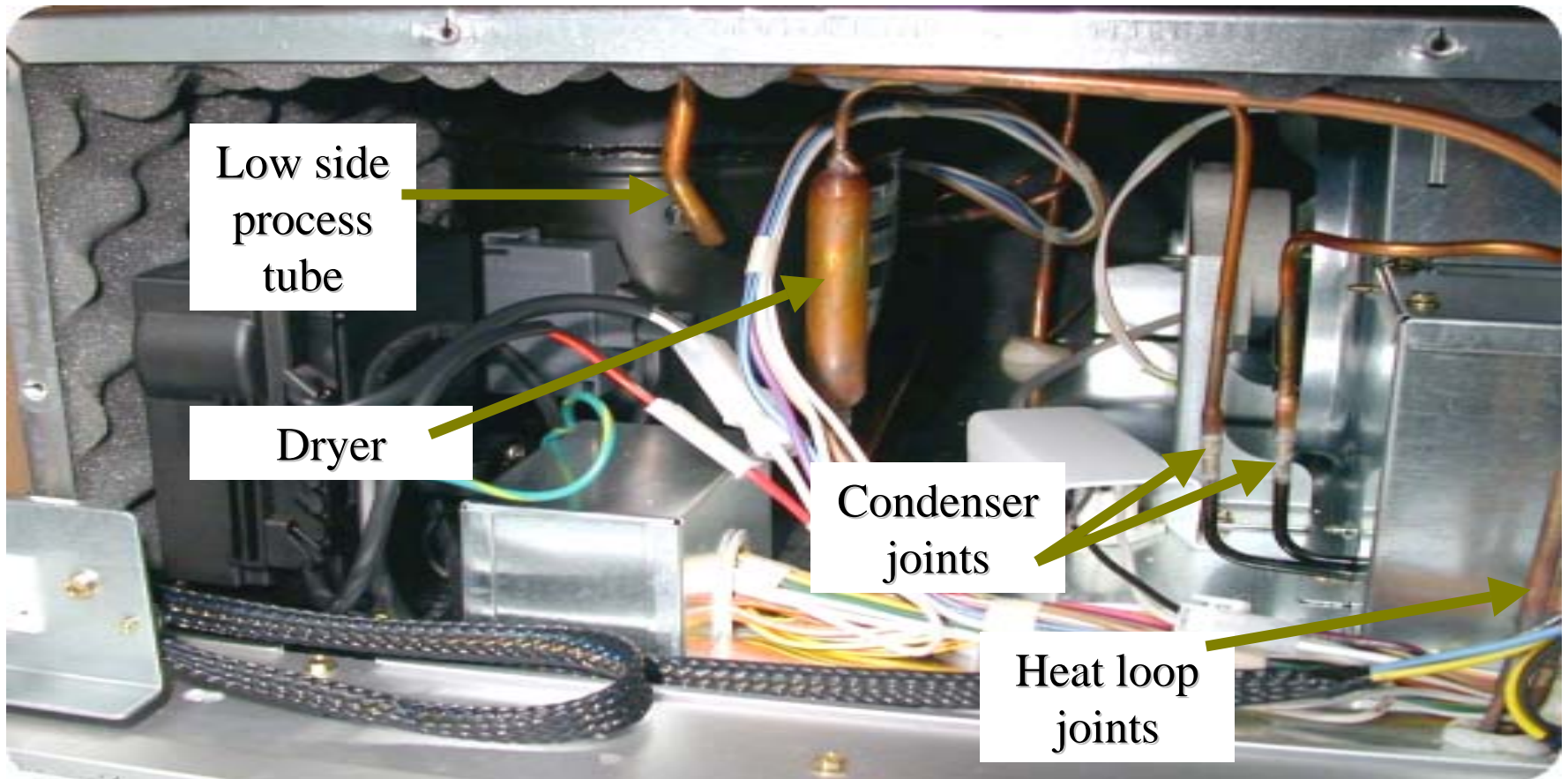

# Sealed System Joints

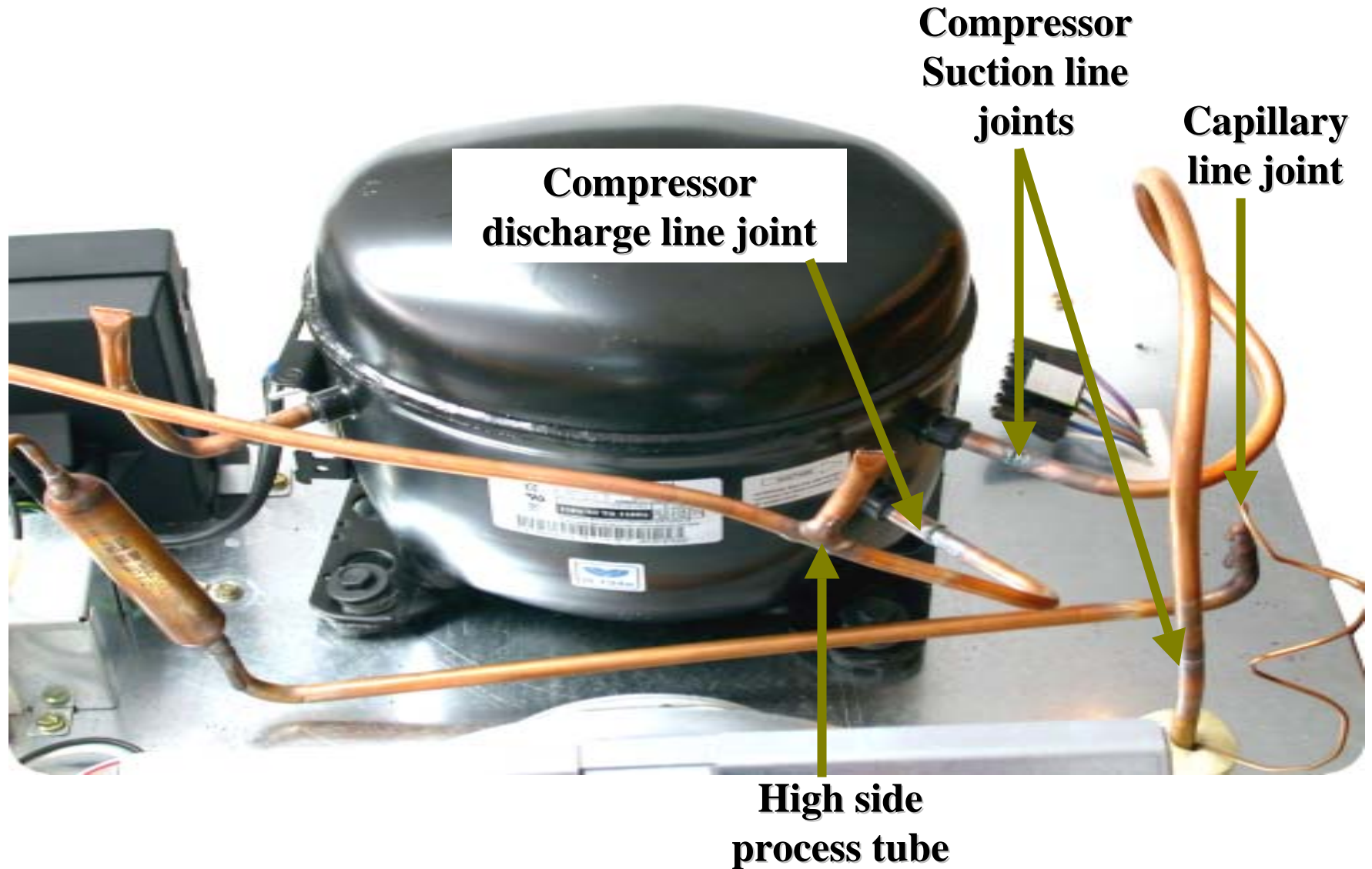



**Suction line  
joint**

**Capillary tube joint**

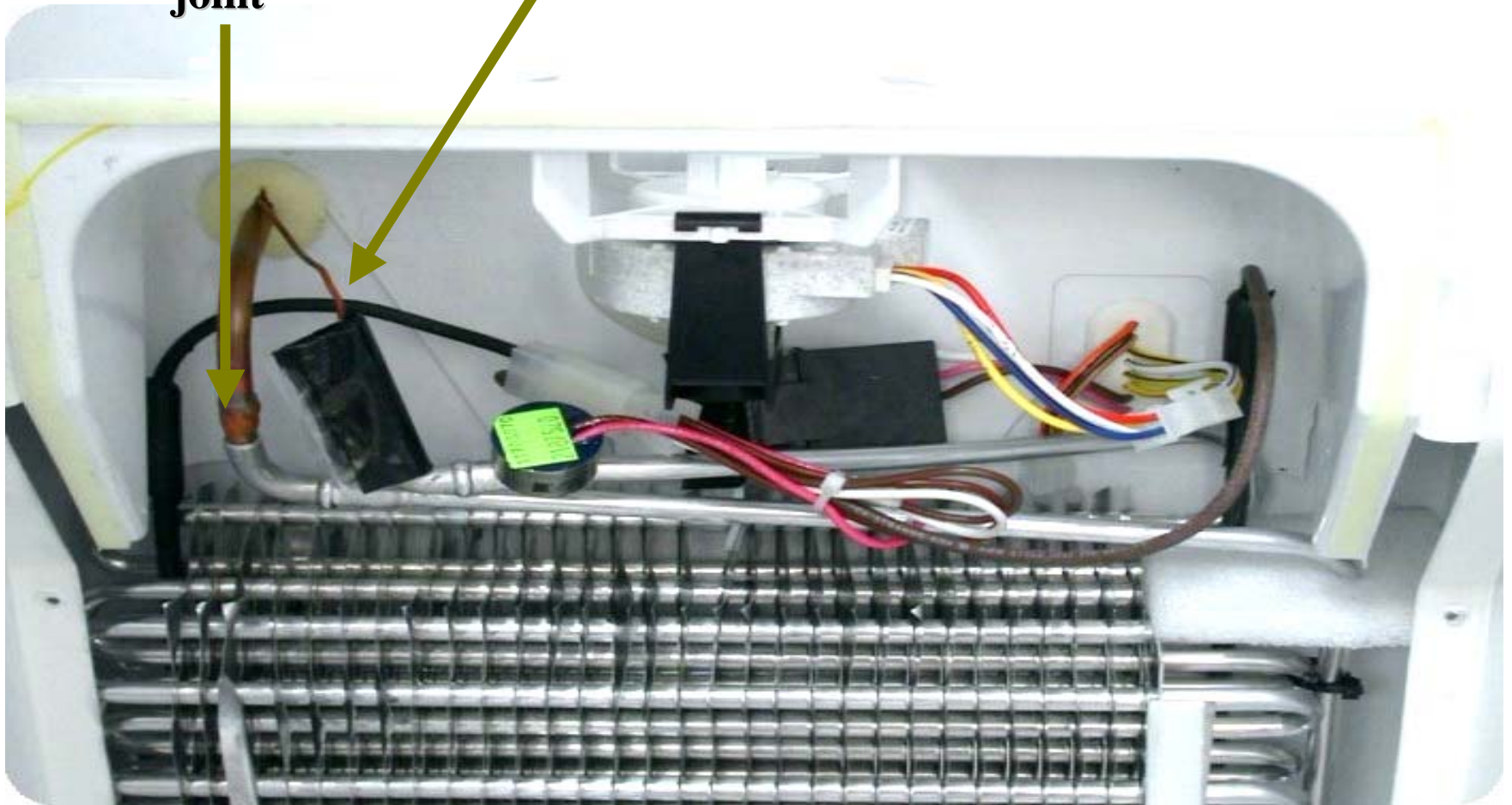

# Sealed System Joints

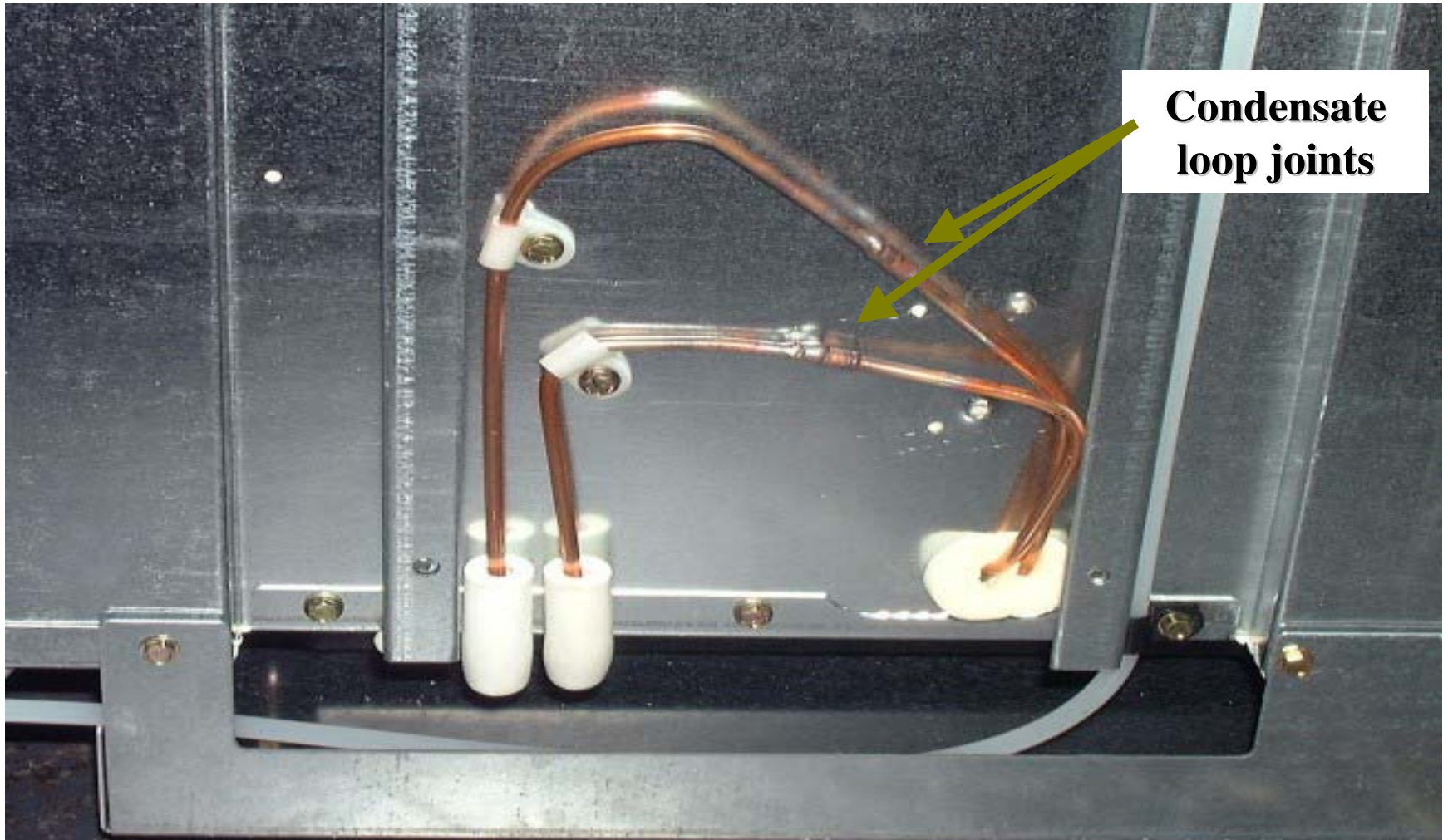

**These joints will be lock ring in the near future**

# **In-Door Ice & Water System**

## **Water Delivery**

- Valve
- Filter

## **Ice Storage**

- Ice bin
- Ice maker door
- Optics Sensor with manual shut off

## **Ice Delivery**

- DC Drive motor
- Coupler
- Ice bin & auger
- Ice Maker



# Water Flow Diagram

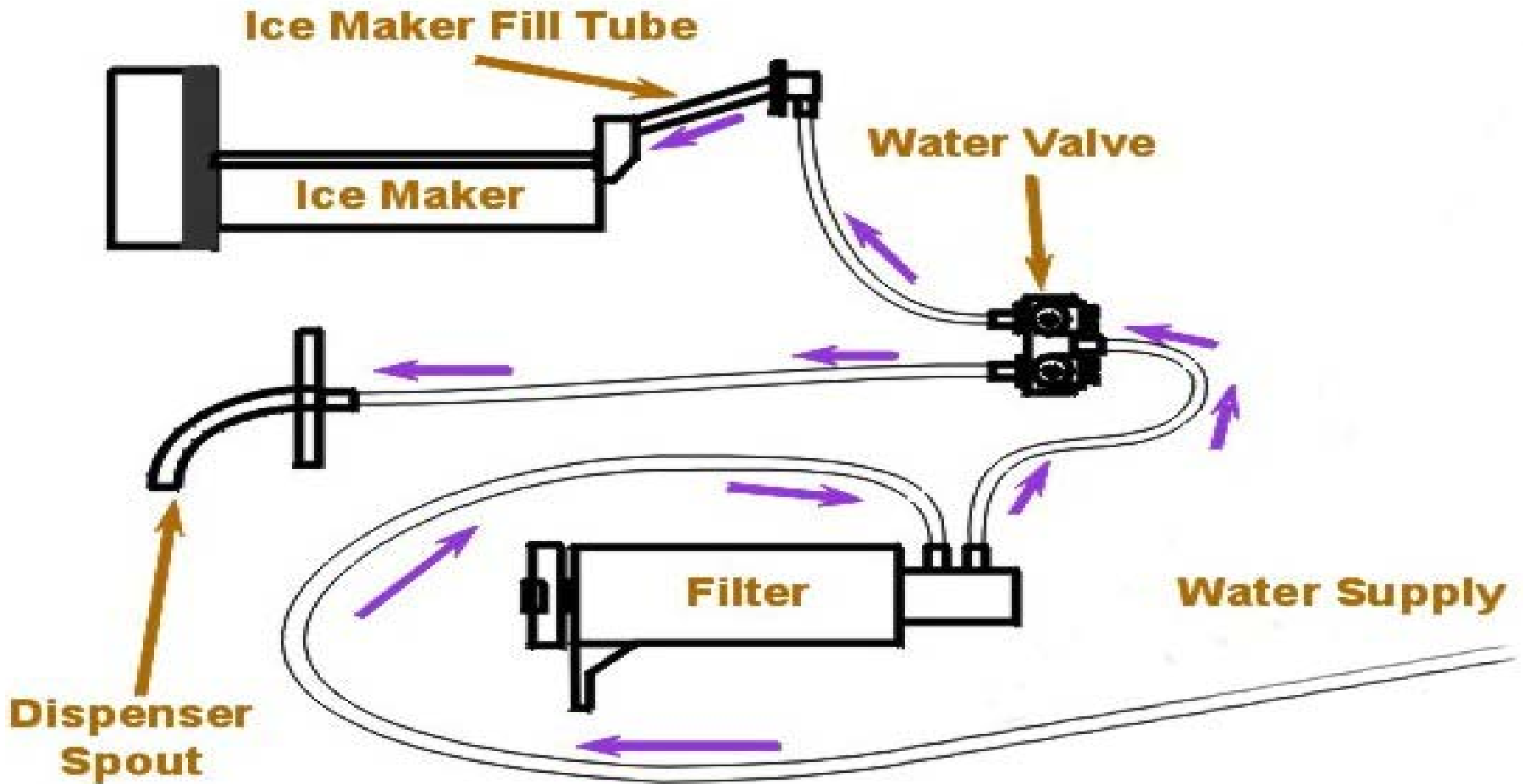



# Inlet Valve

**1/4 inch line to  
release push  
tube lock**



**Flow Washer**

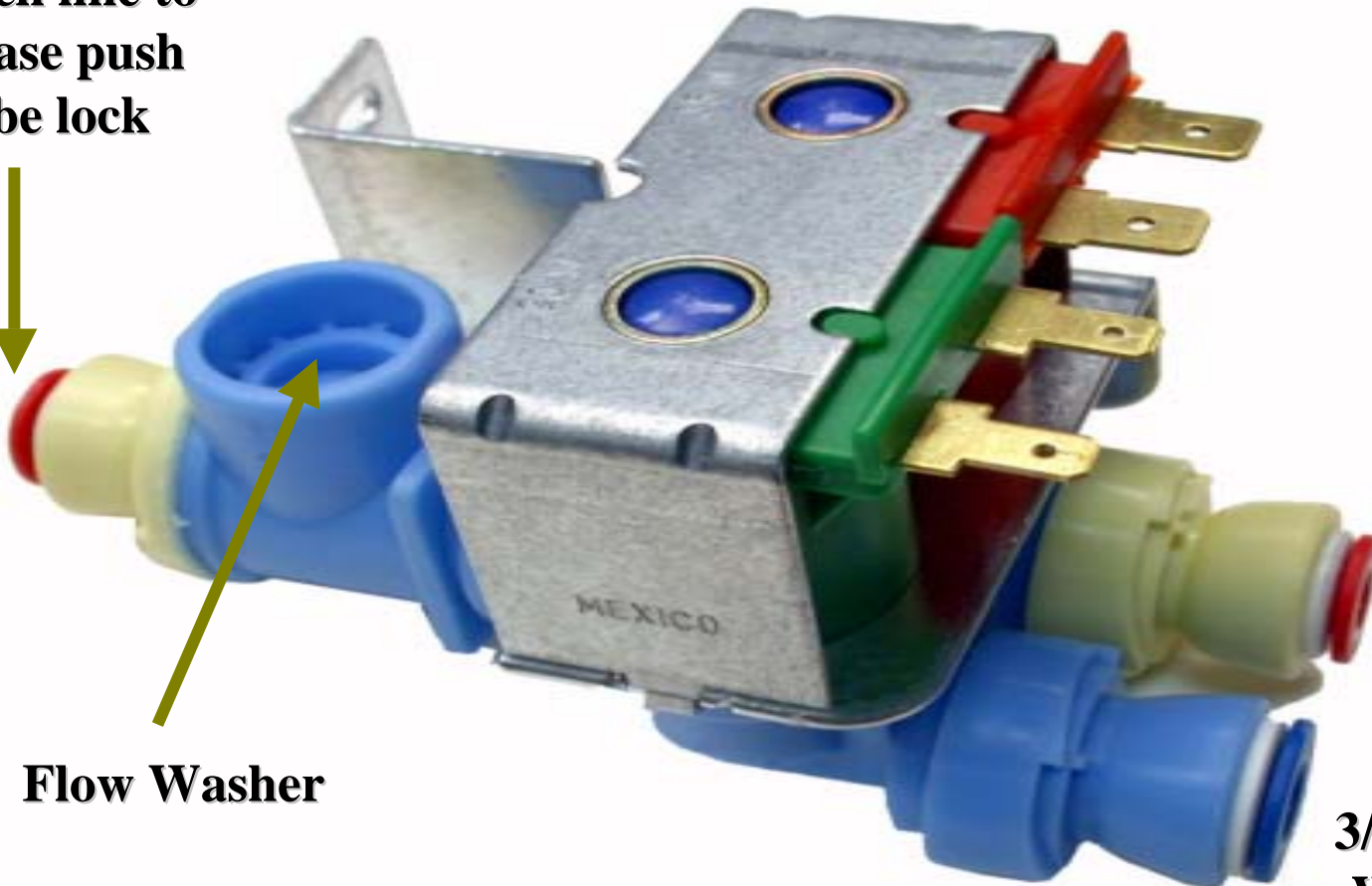

**1/4 inch  
Ice  
Maker**

**3/8 inch  
Water  
Dispenser**



# Inlet Valve



**Channel  
Trim**

**Water valve  
shield**

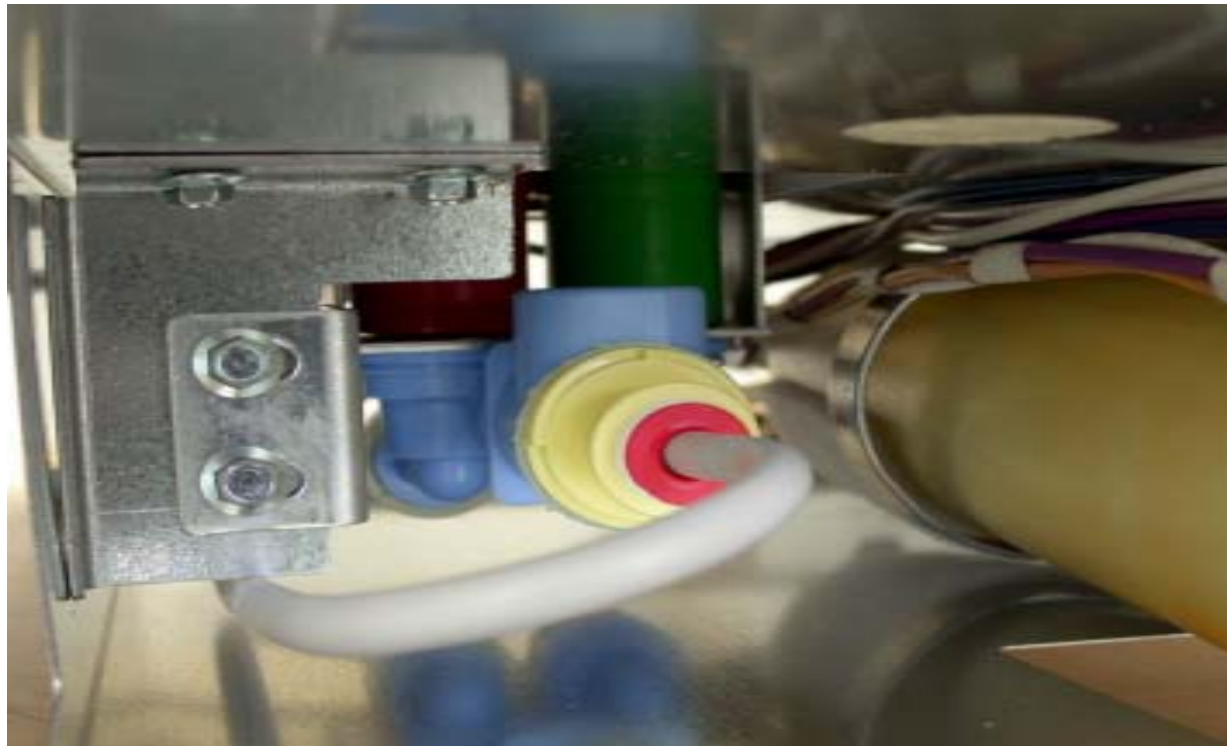

# Inlet Valve



# Through the grill filter

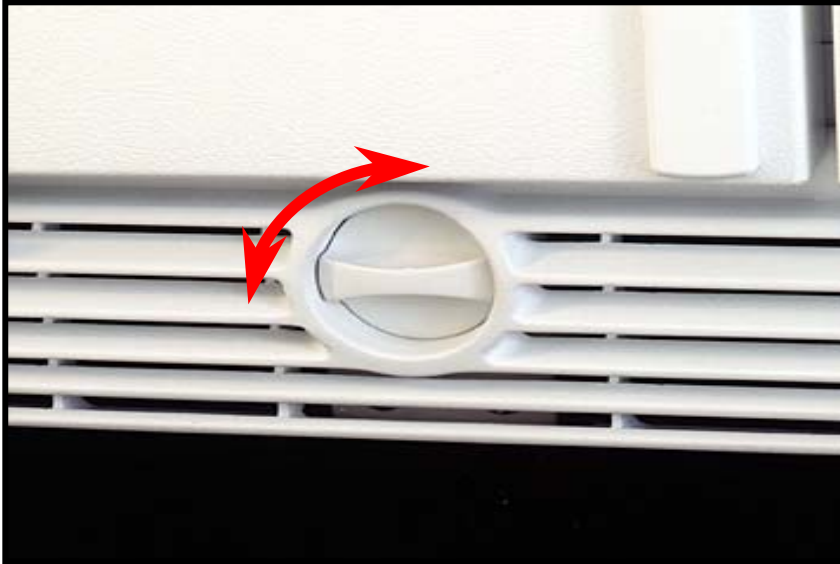

# Filter and Housing





## Heated Fill Tube



**The heated fill tube is energized for 90 minutes  
after each icemaker fill**

# Removing the Fill Tube

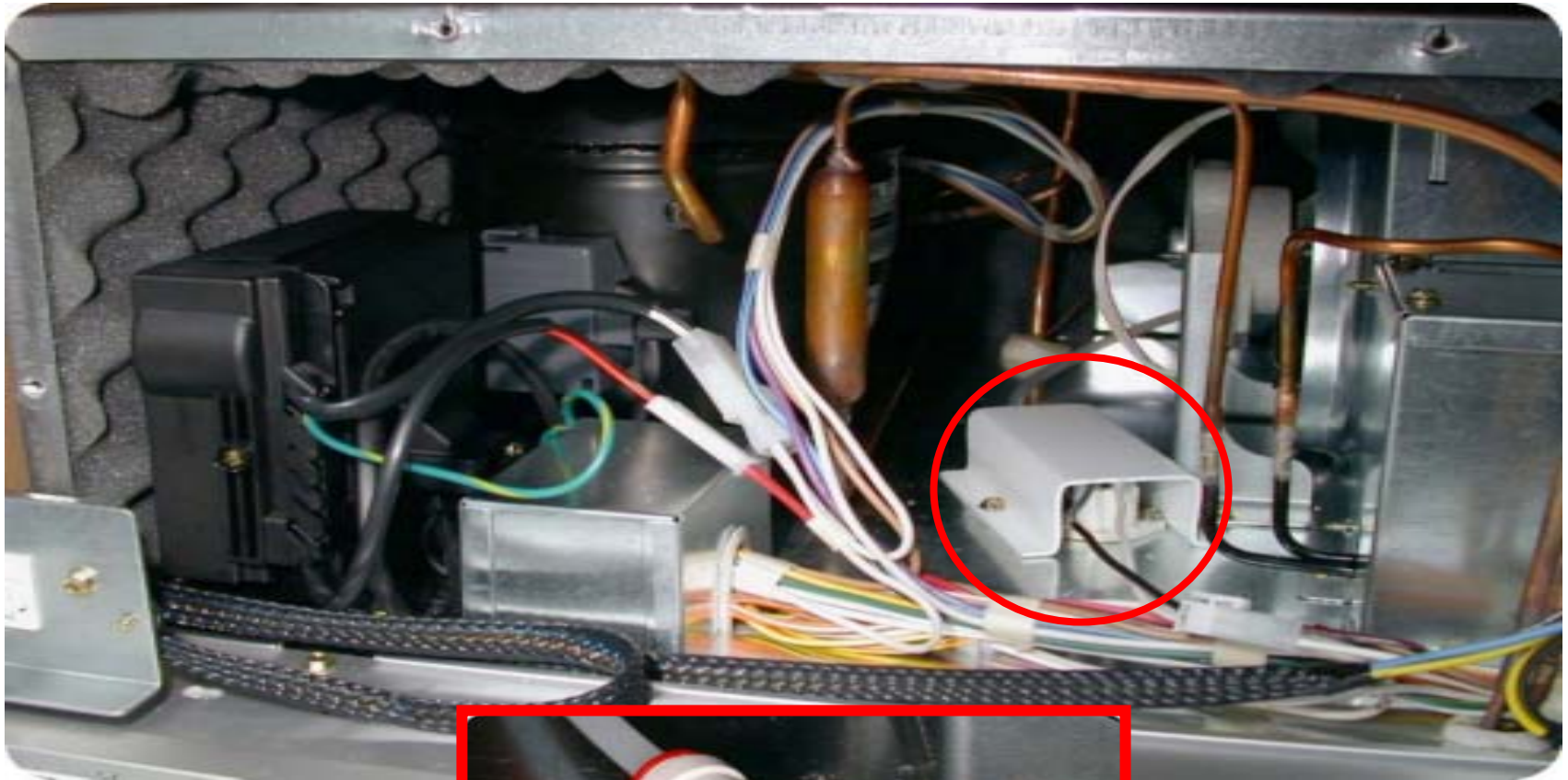

# Ice Dispenser Component Locations

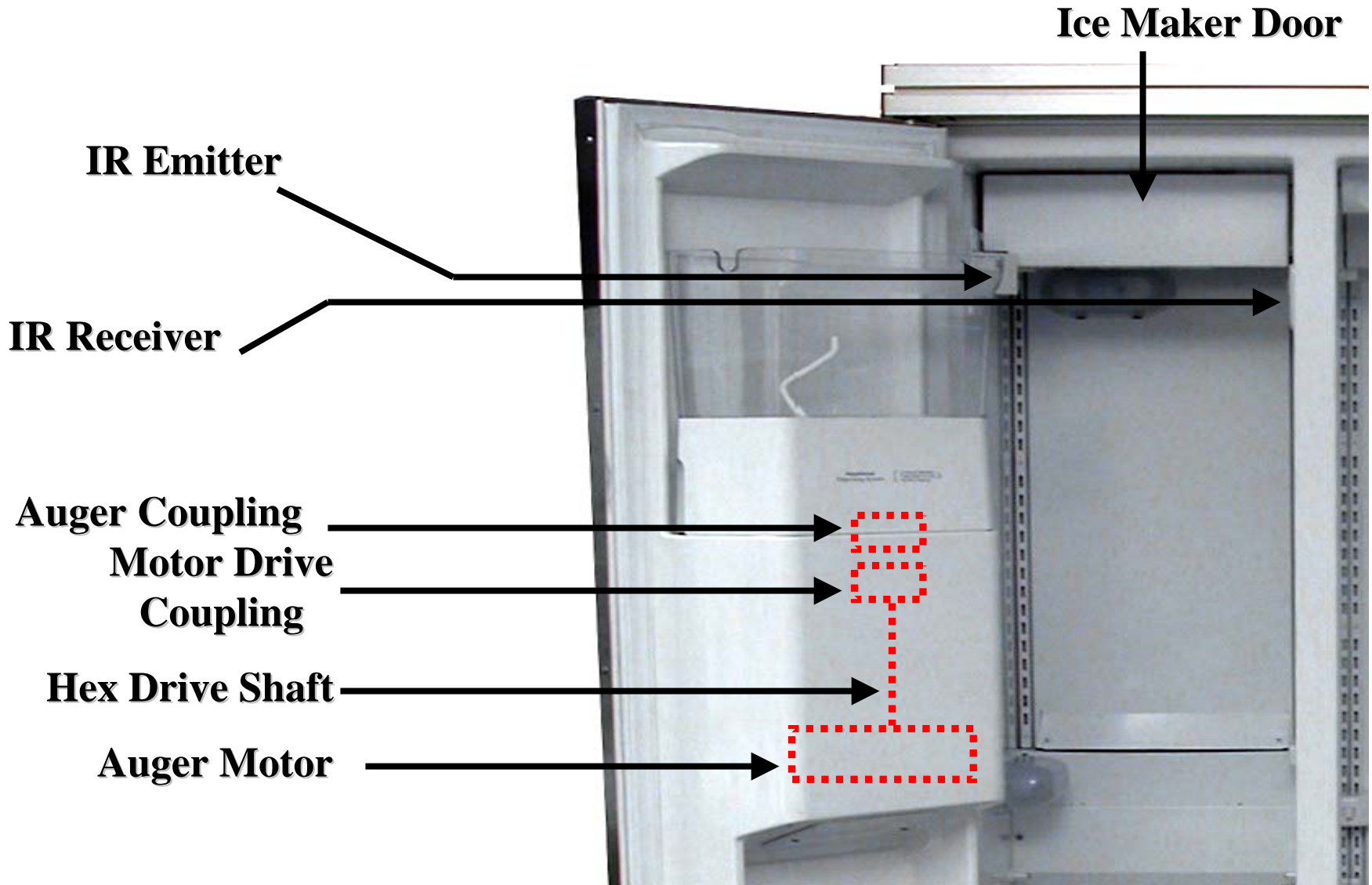



# IDI (**In Door Ice**) Diagnostics

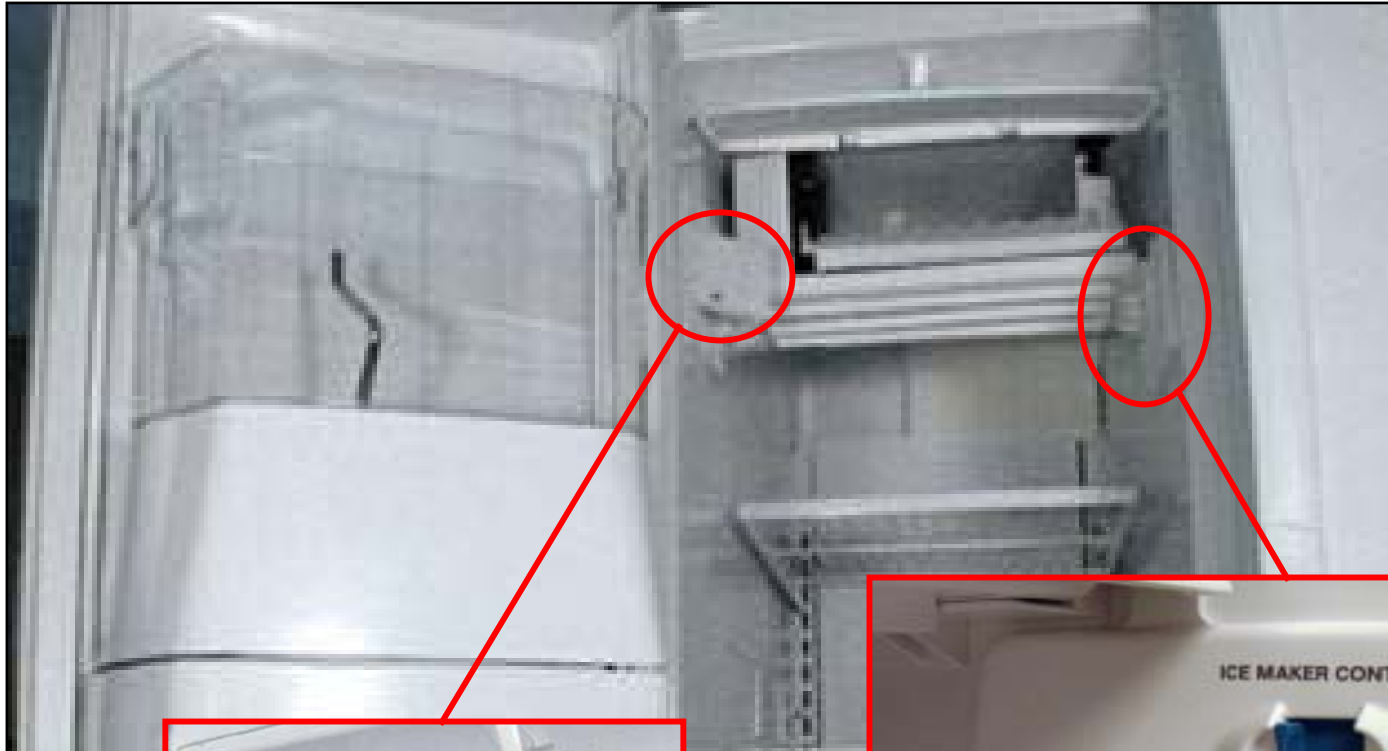

# IDI Diagnostics

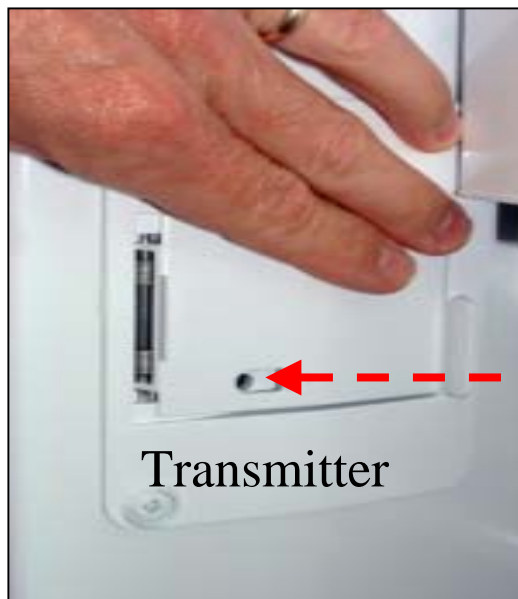

Light Beam

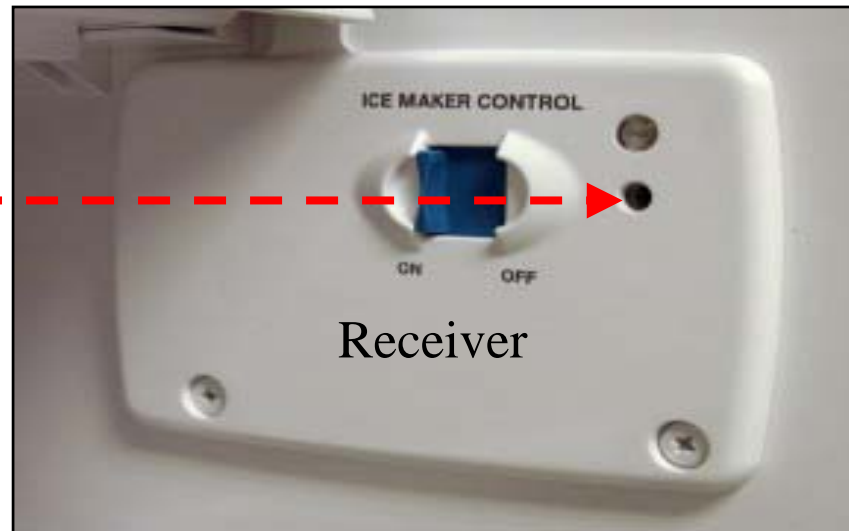

Door opens to block the light beam indicating the Freezer door is open or the ice bucket is missing

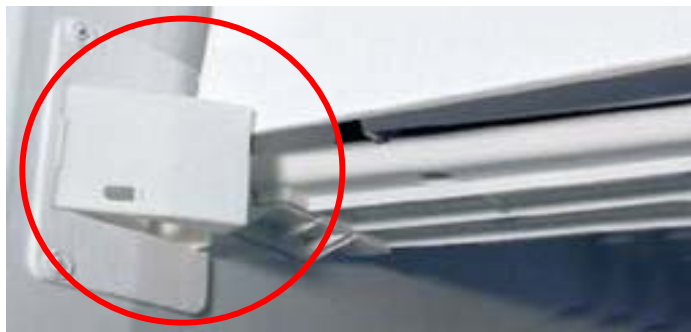

If the Receiver does not “see” the light from the Transmitter the Icemaker power is shut off and no ice will be harvested



# All IDI Icemakers

**False indication of defective control by the diagnostics**

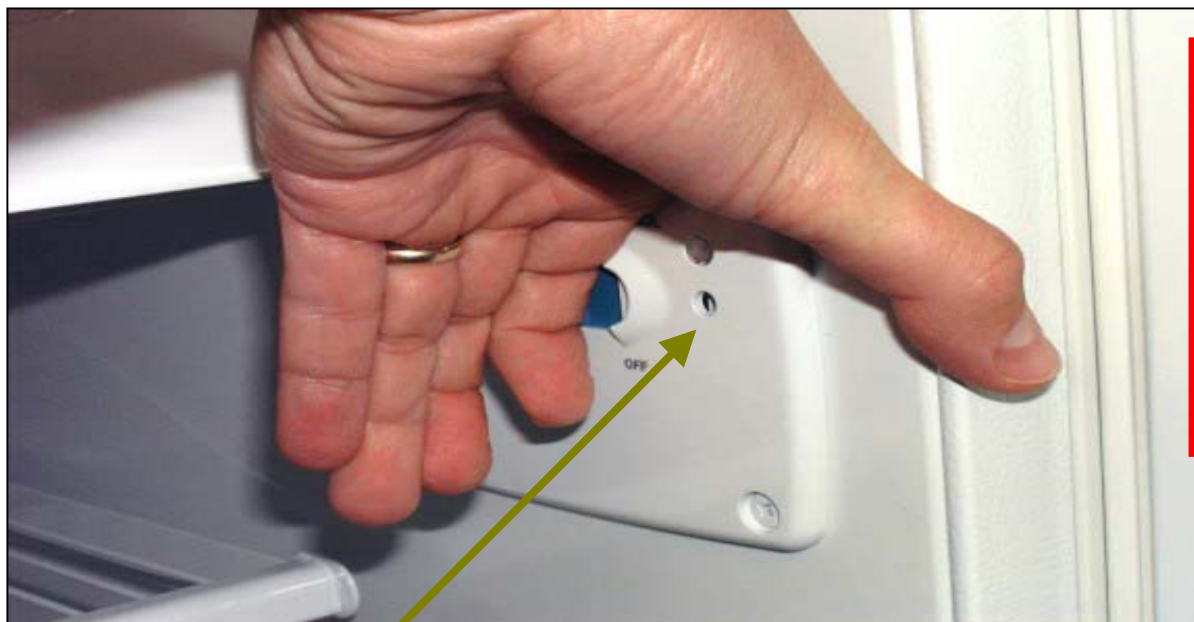

Occasionally ambient light can cause false readings while running the diagnostics and may require you to “shade” the Receiver Port

**Receiver  
Port**



# In Door Ice System

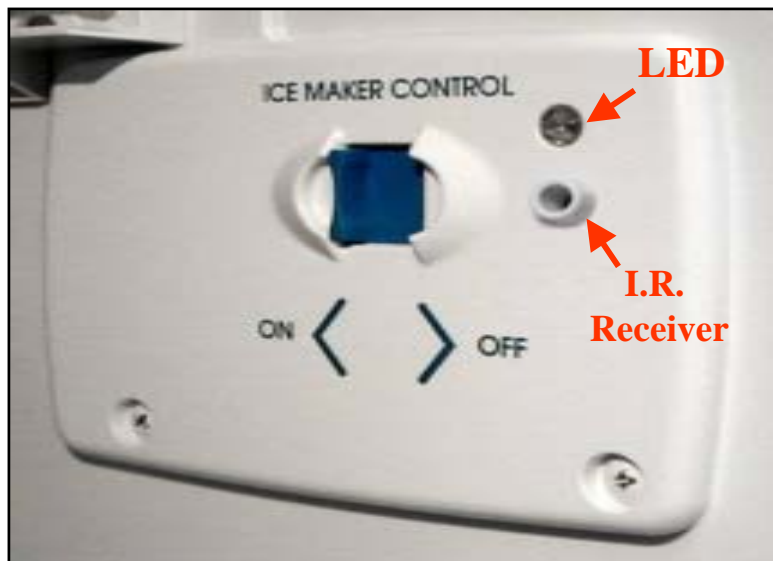

## Optic Diagnostics, 2002 Design, Chart B

STEP #	STATUS LED	POSSIBLE CAUSES	ACTION
1. Open the freezer door.	2 pulses followed by a 1 second delay repeated.	The flapper door on the emitter is blocking the beam.	Go to step 2.
		The optics are faulty.	Go to step 2.
	No lamp.	The ice maker is in the 5 minute harvest mode.	To confirm, hold in the freezer door switch and the LED will flash in 1 second intervals.
		Faulty LED or original style boards are installed.	Replace the optics boards, or perform the steps in chart A.
2. Press in the emitter flapper door to unblock the optics beam.	2 pulses followed by a 1 second delay repeated.	The optics board are faulty.	Replace the optics boards.
	LED is on steadily.	The optics are working properly.	Close the freezer door.

# Removing the Emitter Module



**Disconnect Harness**

Reminder: Safe repair practice requires disconnecting the power before servicing any electronic control boards

# Removing the Receiver Module

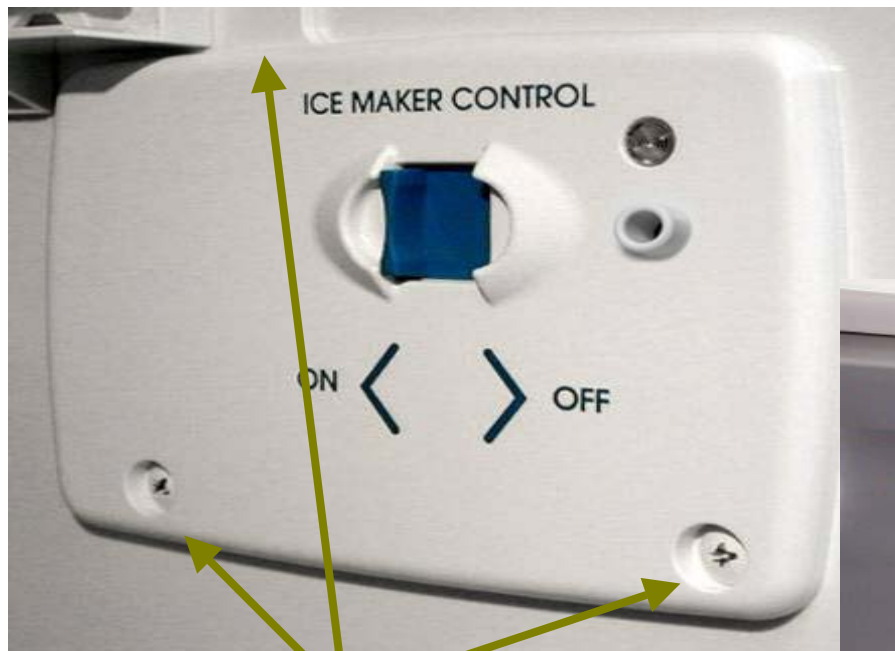

**3 Screws**

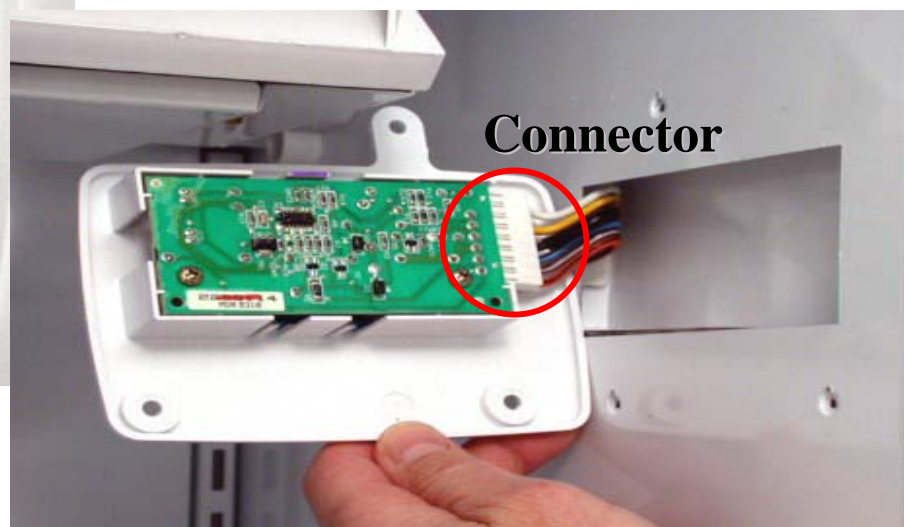

**Connector**

Reminder: Safe repair practice requires disconnecting the power before servicing any electronic control boards



# Accessing the Dispenser Drive Motor



1.) Remove Ice Container





## Checking the Motor

**To check voltages\* at the motor for crushed or cubed ice operation:**

- 1. Open the freezer door and remove the ice bin from the door.**
- 2. Tape the door switch closed.**

**\*Voltage readings may vary, depending on the supply voltage, and the type of test equipment being used**

**Door Switch  
Taped Closed**



# Checking the Motor



**Motor Harness Connector**

**Press Tips Into Connector Slots Against Bare Wire Terminals To Check Voltages**



**Press the Ice Dispenser Lever**

## Wire Harness Pinouts

+115 VDC	7 ○	To Switch Pack (OR/BU)
-115 VDC	6 ○	To Switch Pack (PK/BK)
Neutral	5 ○	(WH)
	4 ○	No Connection
L1 (115 VAC)	3 ○	(BU)
Motor (115 VDC)	2 ○	From Switch Pack (RD/WH)
Motor (115 VDC)	1 ○	From Switch Pack (BR/WH)

# Removing the Dispenser Drive Motor

## 1.) Remove Harness Connector

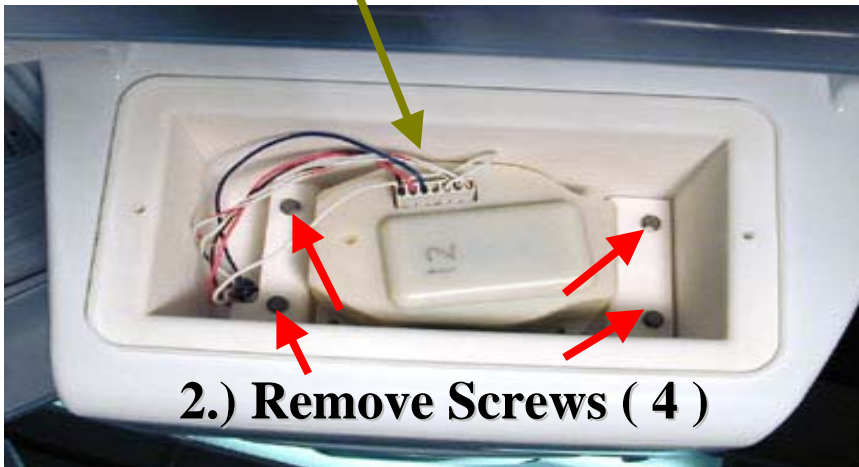

Use care not to pinch or damage the harness during motor removal or reassembly

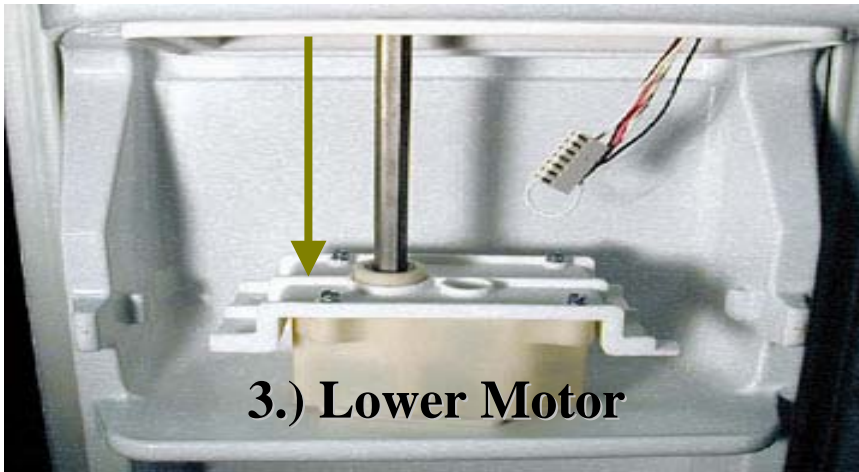

# Reinstalling the Motor

**Drive Coupling**

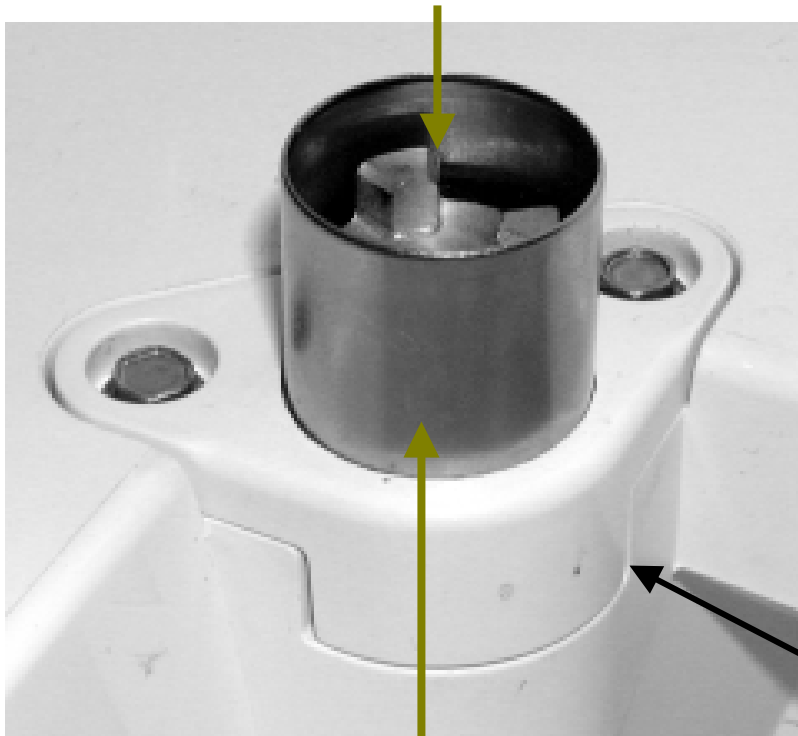

**Alignment Collar**

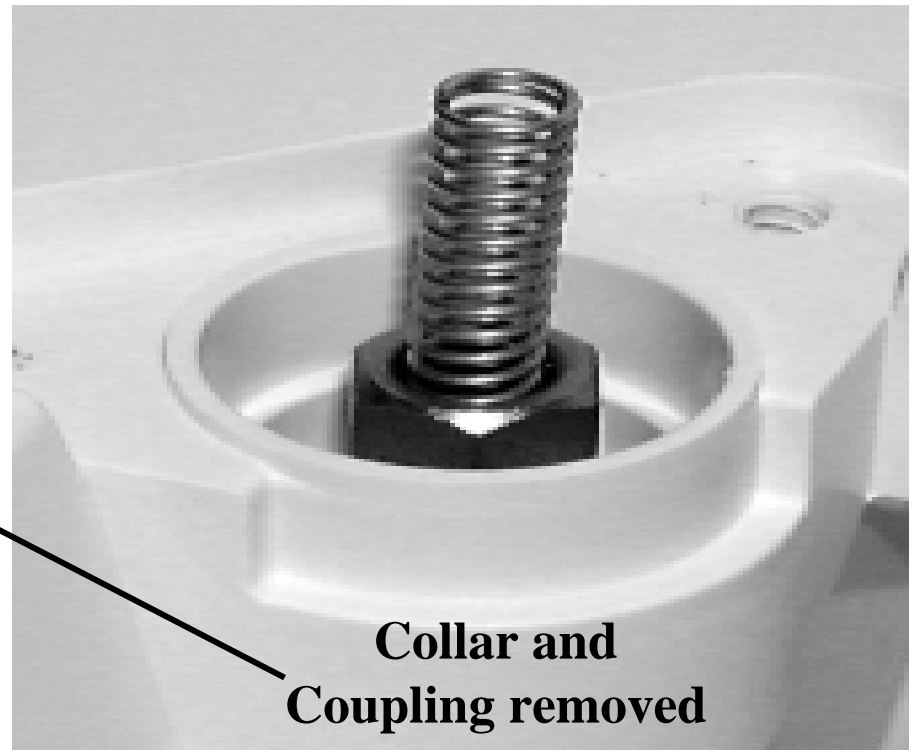

**Collar and  
Coupling removed**

# Reinstalling the Motor

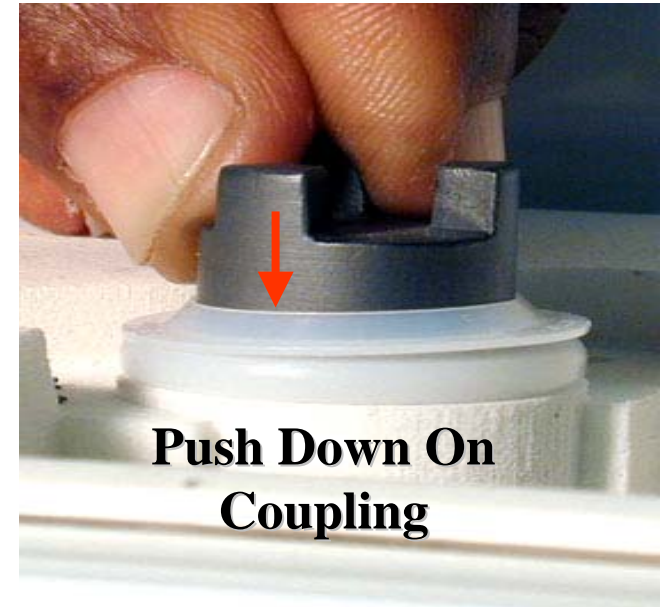
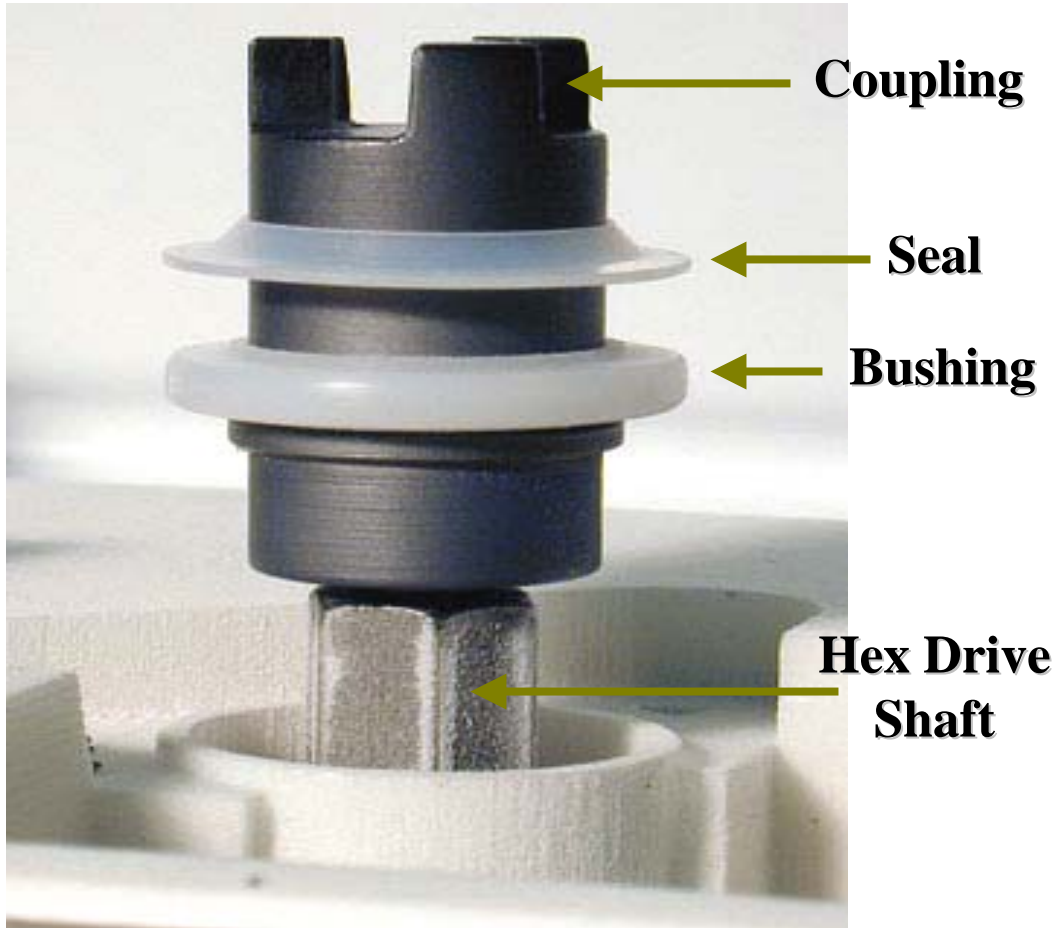

**Push Drive Shaft into Motor**





# Reinstalling the Ice Bin

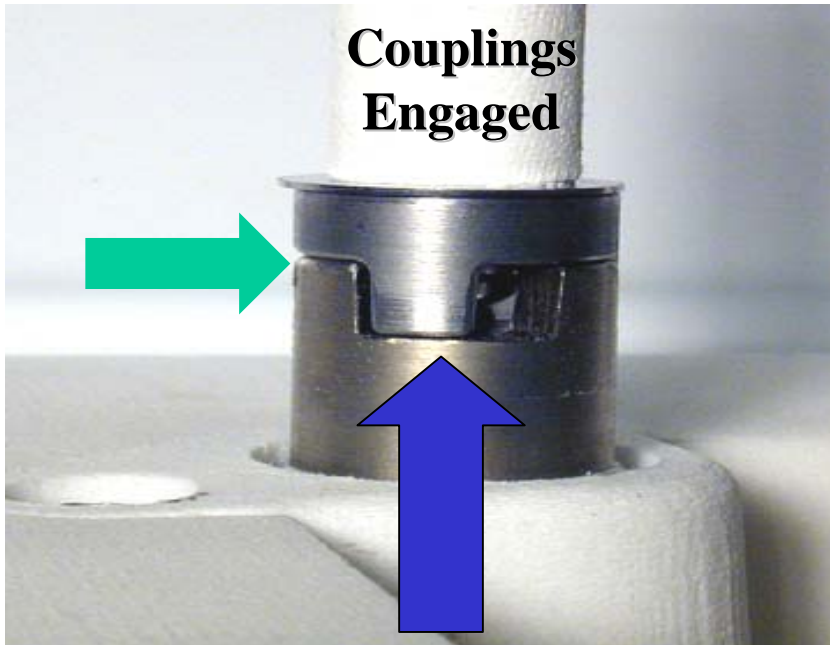

**Motor Coupling Snaps Up**

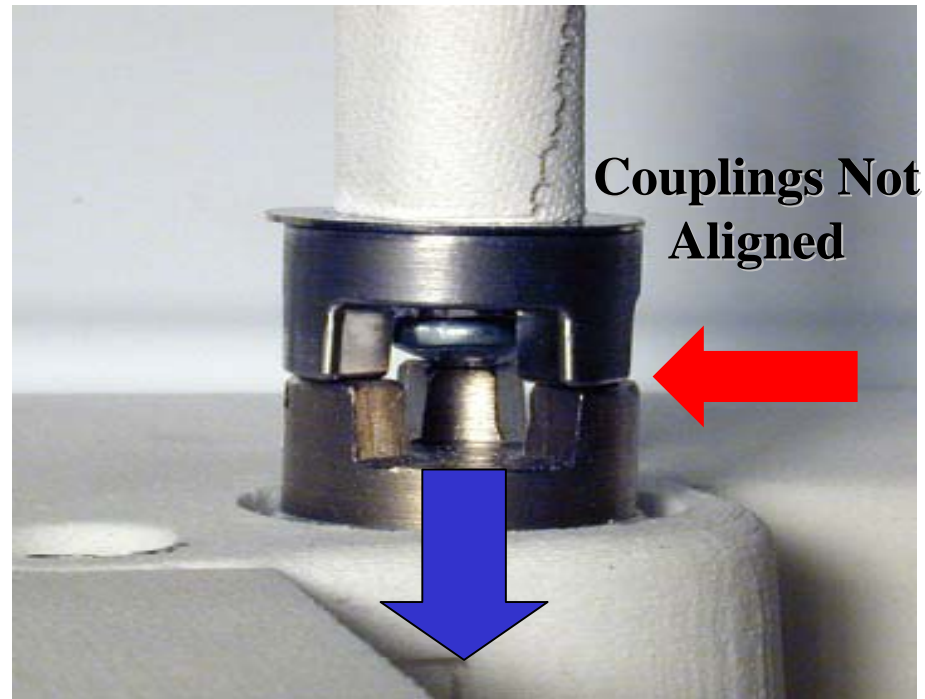

**Motor Coupling Depressed**

Couplings automatically align when dispenser starts



# Removing the Ice Maker



**Emitter Door Open**



**Close Emitter Door**

**Open Ice Maker Door**

**Slide Hinge Pin Out Of Holder**

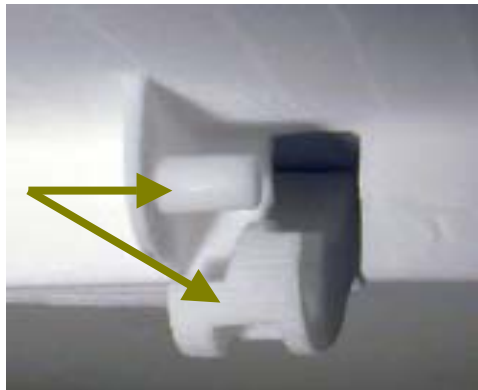

# Removing the Ice Maker



# Diagnosics & Troubleshooting

## Component Diagnostics

If the optics are working but there is no ice production you will need to check the components.

**IMPORTANT:** If the freezer temperature is not cold enough to allow the ice maker bi-metal to close, a shunt must be installed in the ice maker and the test re run.

**NOTE:** The optics must be working properly to test the ice maker. If the optics test fails, you will not be able to force a harvest and check the ice maker



**Shunt  
"T" to "H"**

# Manually Starting an IDI Ice Maker

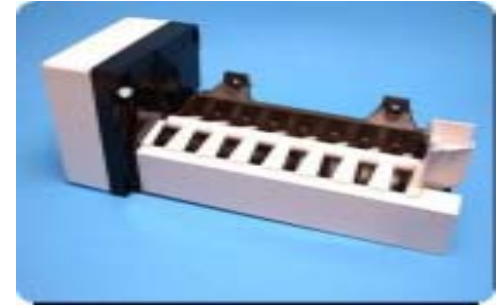

- **Jump test points “T” TO “H”.**
- **Make sure the ice bin is on the door, the IDI slide is “on” and both doors are closed.**
- **Unplug the product or turn off the power for 10 seconds**
- **Reapply power.**
- **After 10 seconds, open and close the freezer door one time.**
- **After 15 seconds, open the freezer door. The ice maker should be running.**
- **Remove the jumper from test points “T” to “H”.**

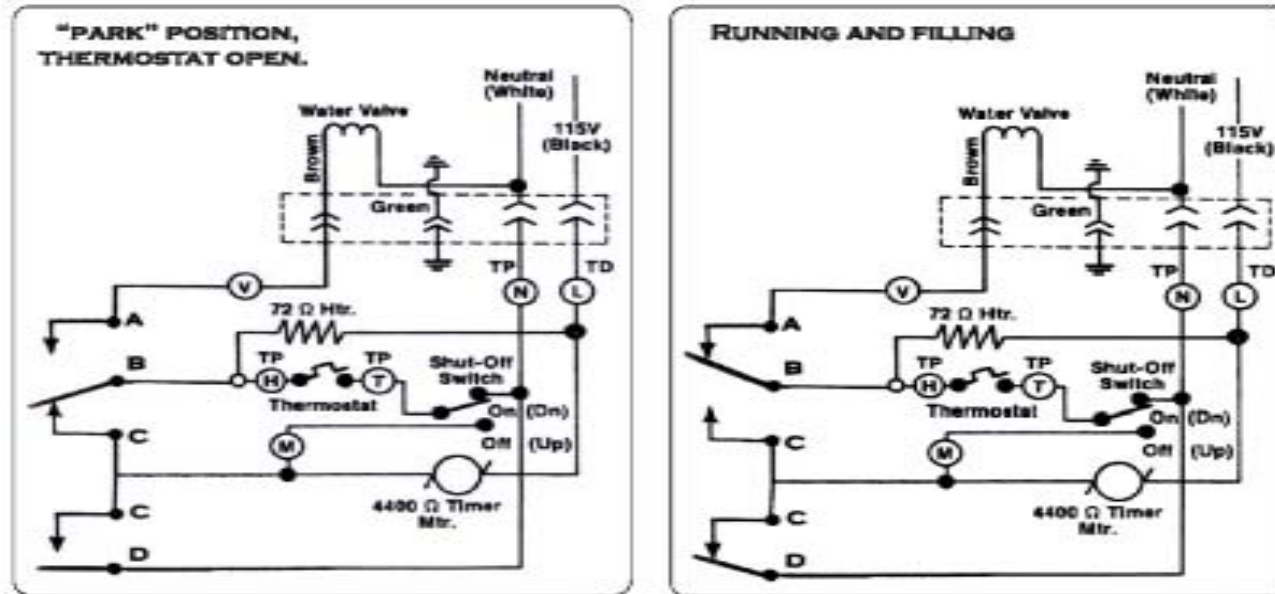

## WHAT HAPPENS DURING BLADE ROTATION VIEWED FROM THE FRONT, (MODULE SIDE)

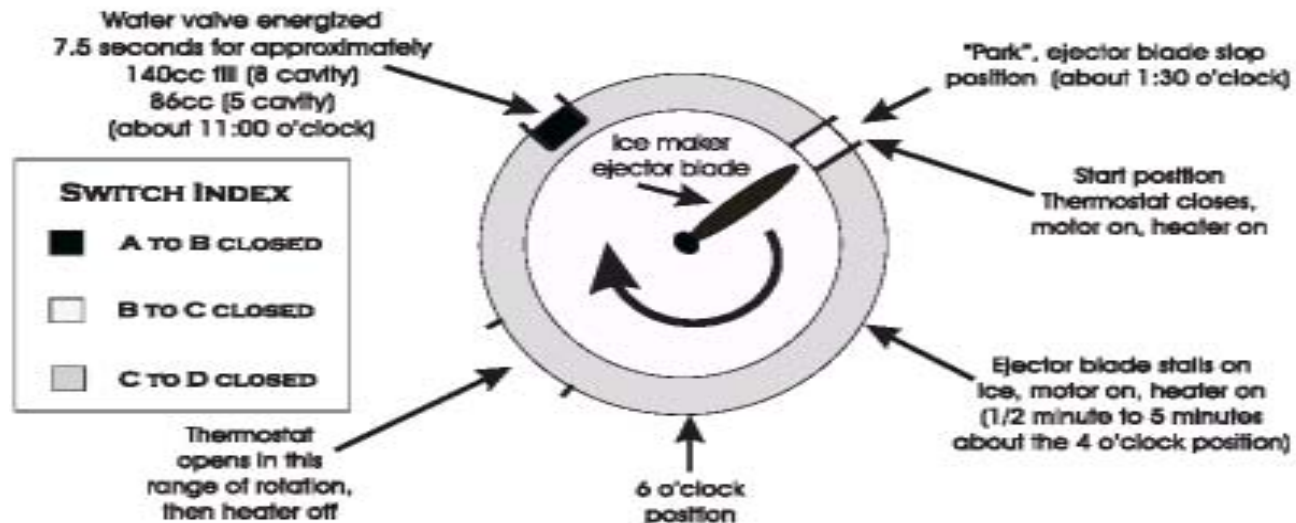



**RUNNING AND FILLING**

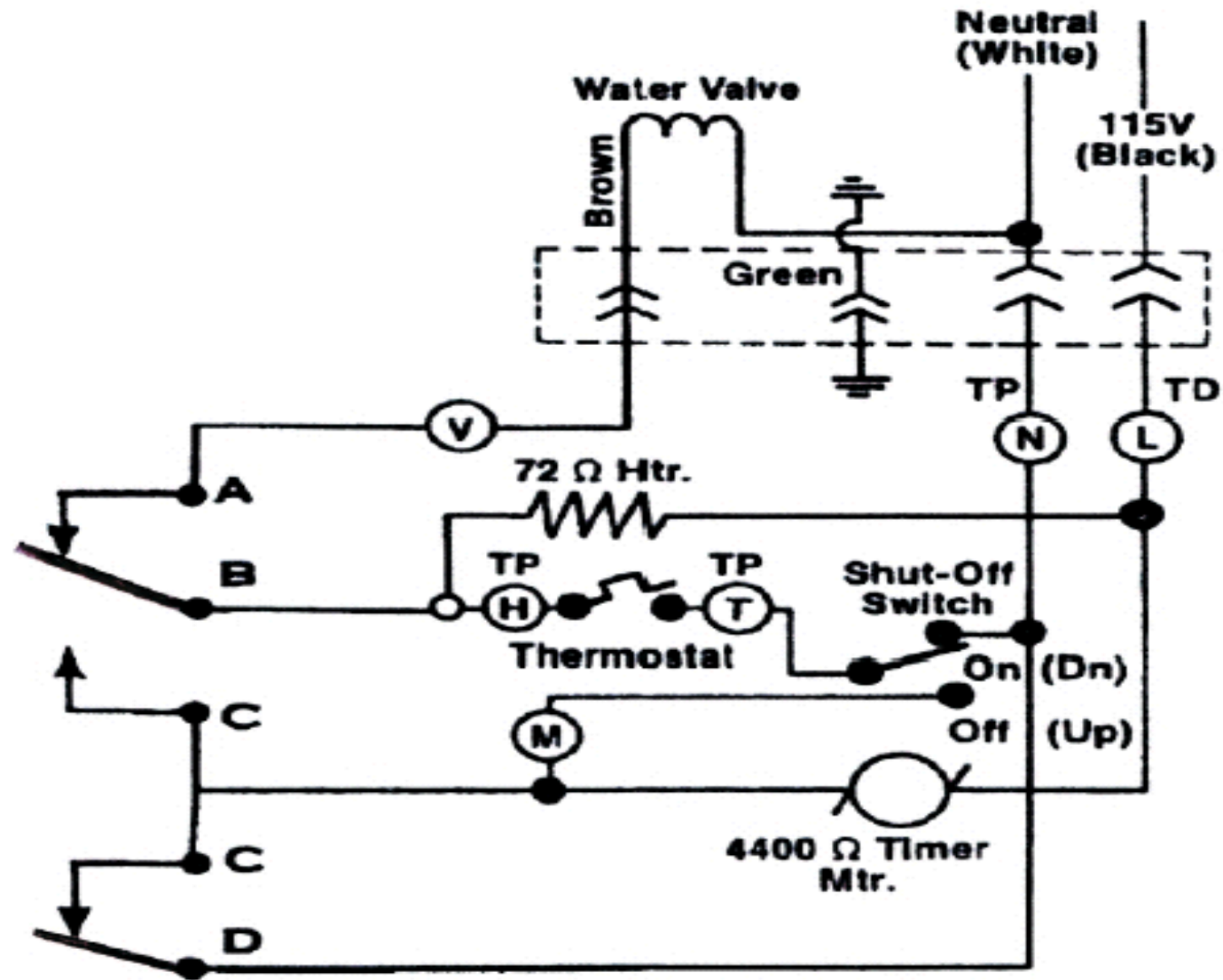



# In Door Ice System....Component Diagnostics

1. Disconnect the power supply.
2. Slide the ice maker out and remove the cover.
3. Jump "T" to "H" to bypass the bi-metal.
4. Reconnect the power supply.
5. Close the freezer door to align the optics and a harvest will begin in 5 seconds.
6. Open the freezer door and observe the icemaker. A harvest should be in progress.
7. Remove the jumper before the fingers reach the 10:00 position. Reinstall the icemaker.
8. Disconnect the power supply immediately after the fill.
9. With the freezer door closed, reconnect the power supply.
10. Wait 5 to a max. of 50 seconds and open the freezer door and watch the status LED.
<b>Status LED Output Codes</b>
<b>4 PULSES</b> , repeated once indicates the relay is defective. Replace the boards.
<b>3 PULSES</b> , repeated once indicates the optics and relay are okay but the ice maker is not being sensed or will not operate, If this happens:
* Check the bail arm switch to make sure it is On.
* Check the ice maker circuit and the connections back to the board and neutral.
* Check the ice maker components.
<b>2 PULSES</b> , repeated once indicates the optics are blocked or defective. Clear the optics path and repeat the test. Replace the board if necessary.
<b>STEADY LIGHT</b> for 5 seconds indicates the relay and optics are okay and the receiver senses the ice maker.
<b>NO LIGHT:</b> Unplug the refrigerator and repeat the test.

**NOTES:**

- 1. Once an error is sensed during the self-diagnostics, the diagnostics LED routine is stopped. Remaining tests in the sequence are skipped.**
- 2. Pulses refer to a flashing diagnostics LED**

# Selector Switch Pack and Dispenser Switches

**Ice Dispenser Switch**

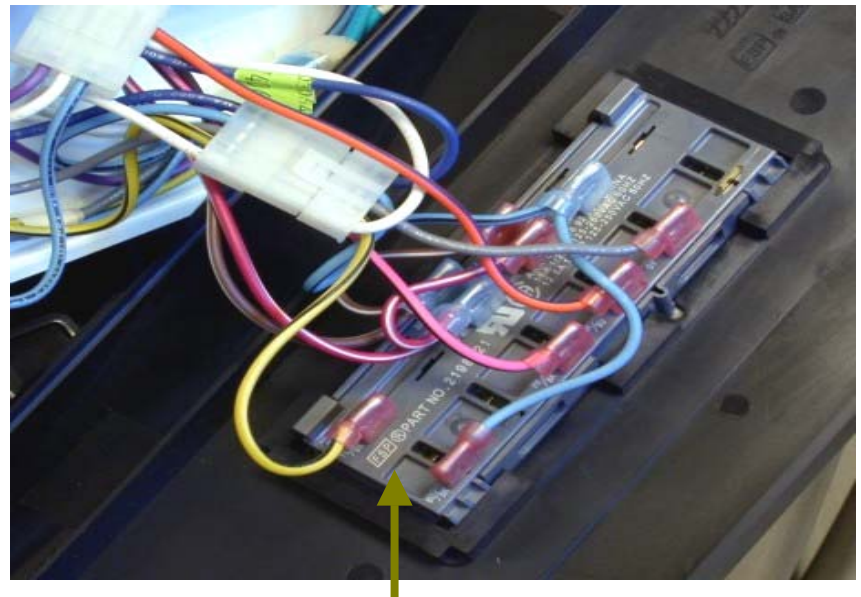
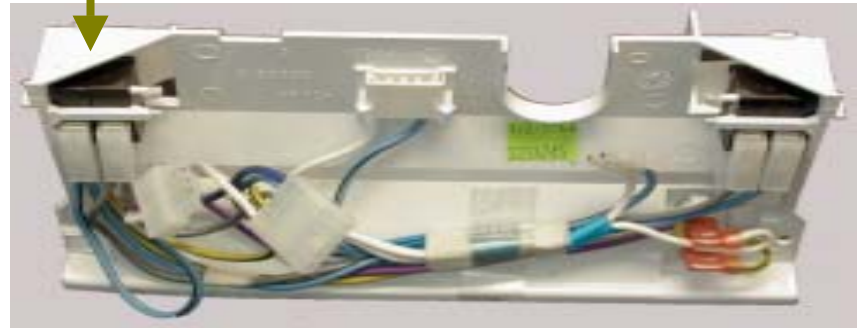

**Drip Tray**

**Selector Switch Pack**

# Checking the Switch Pack

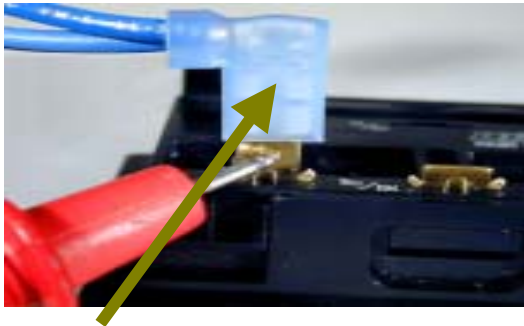

**Lift**

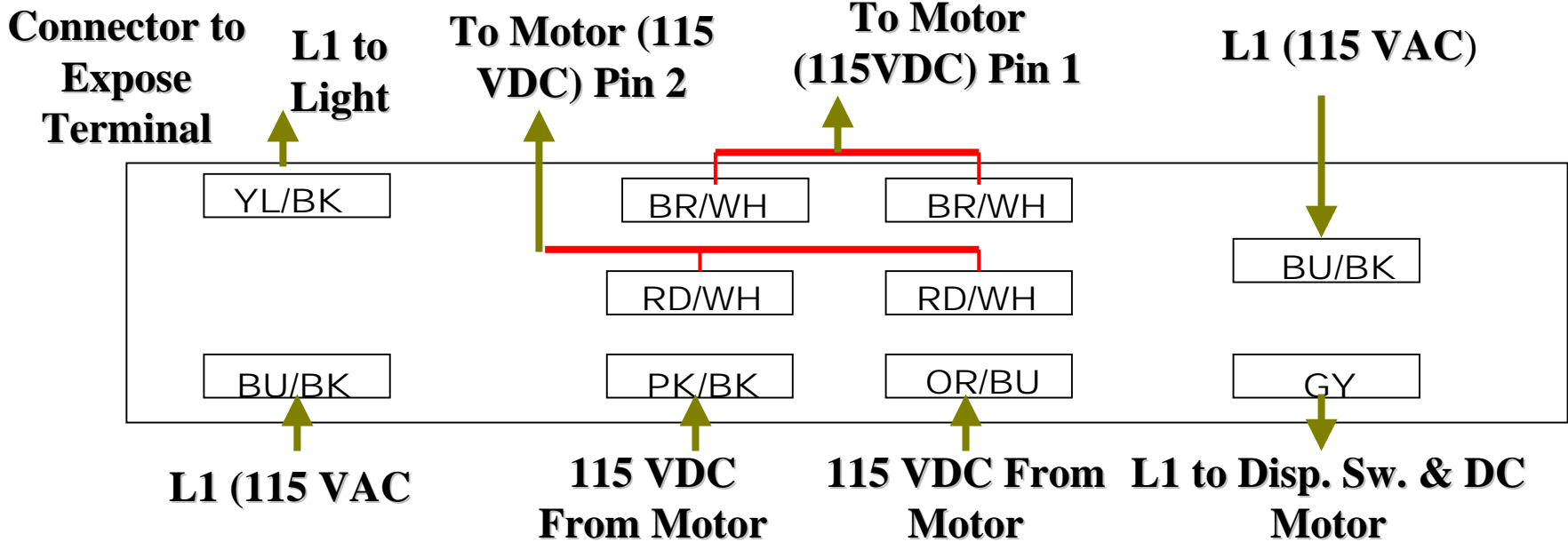
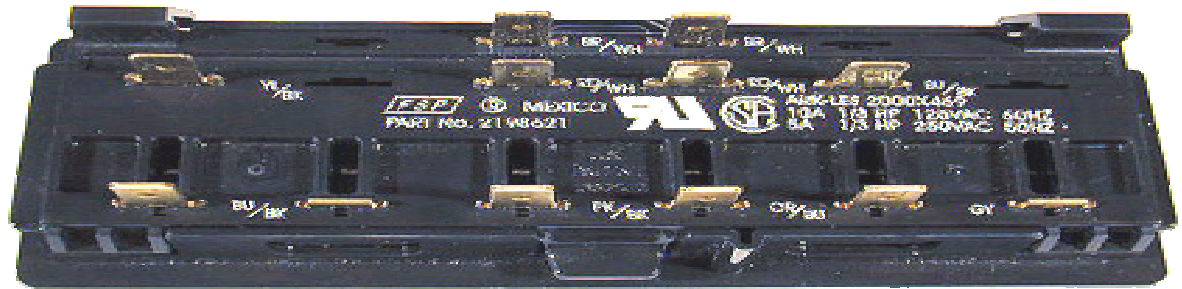

**Crushed Ice Switch = Continuity from OR/BU (com) to RD/WH wires, and PK/BK (com) to BR/WH wires.**

**Cubed Ice Switch = Continuity from OR/BU (com) to BR/WH wires, and PK/BK (com) to RD/WH wires**

# Servicing the Harness & Motor Connector

**Wire Terminal Slot**

**Screwdriver**

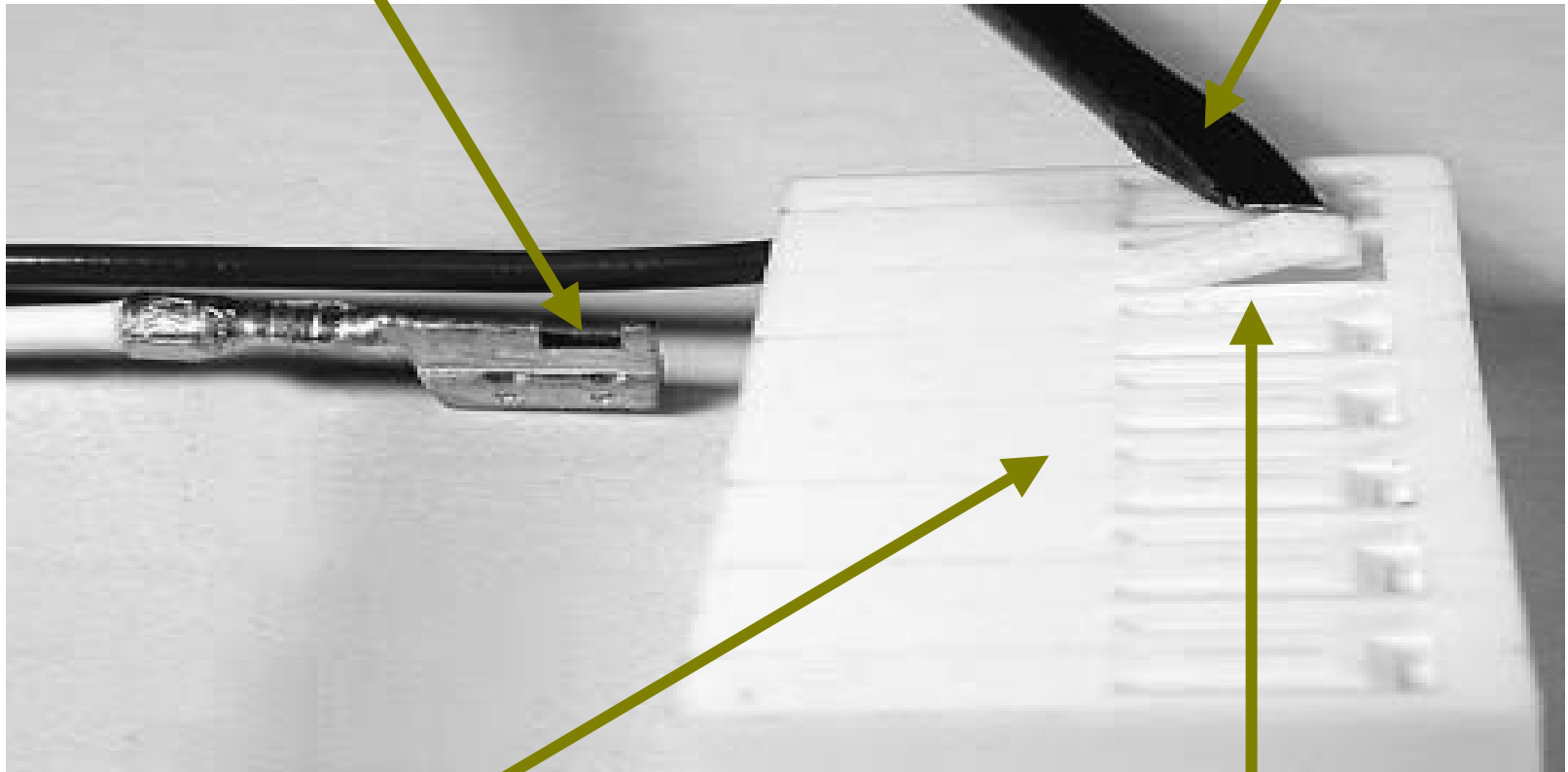

**Motor Connector**

**Wire Retainer Tab**

# IDI Dispenser Diagram

Power from freezer interlock switch

Dispensing valve operation output to WFI board

115 VDC output OR/BU & PK/BK

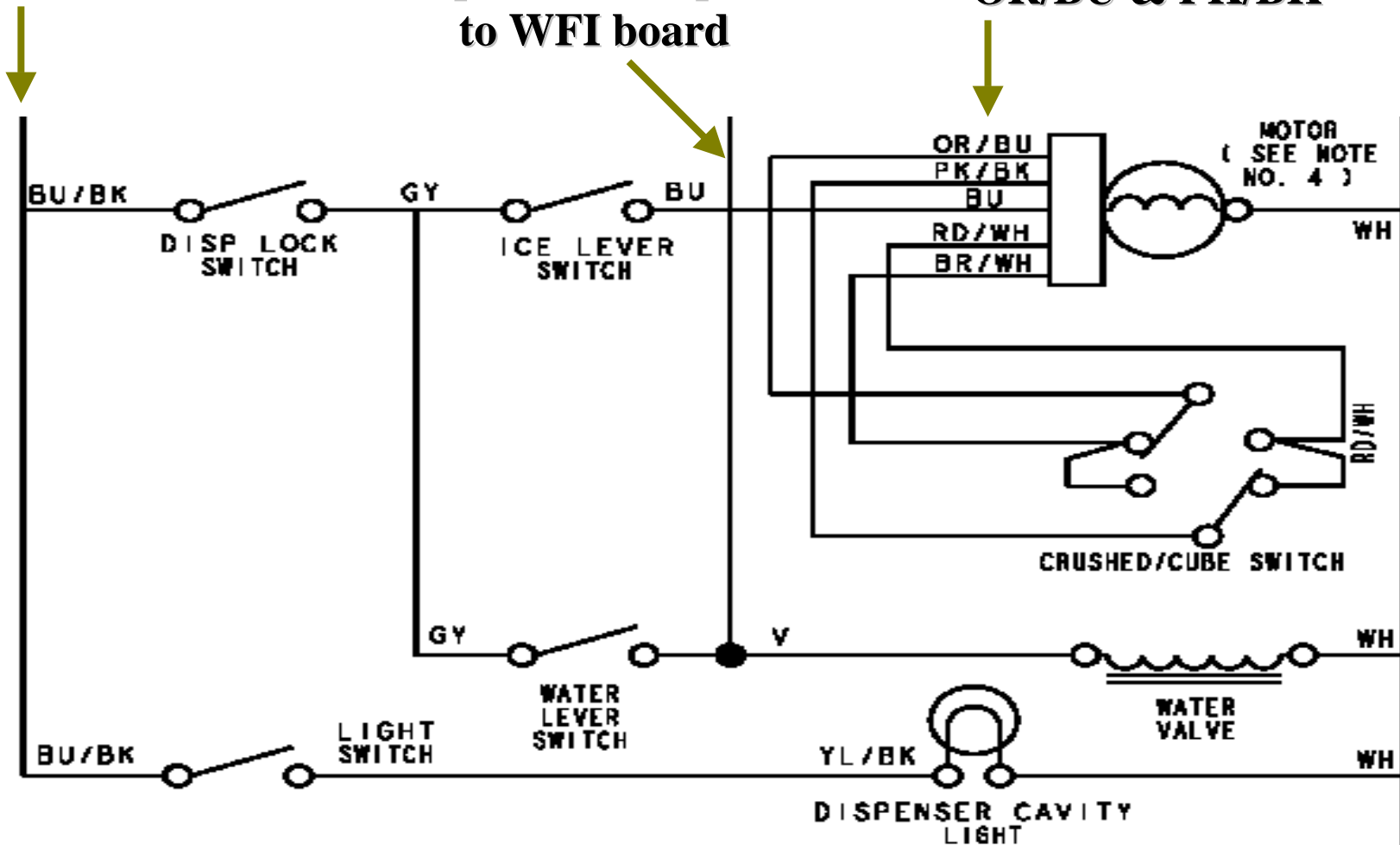

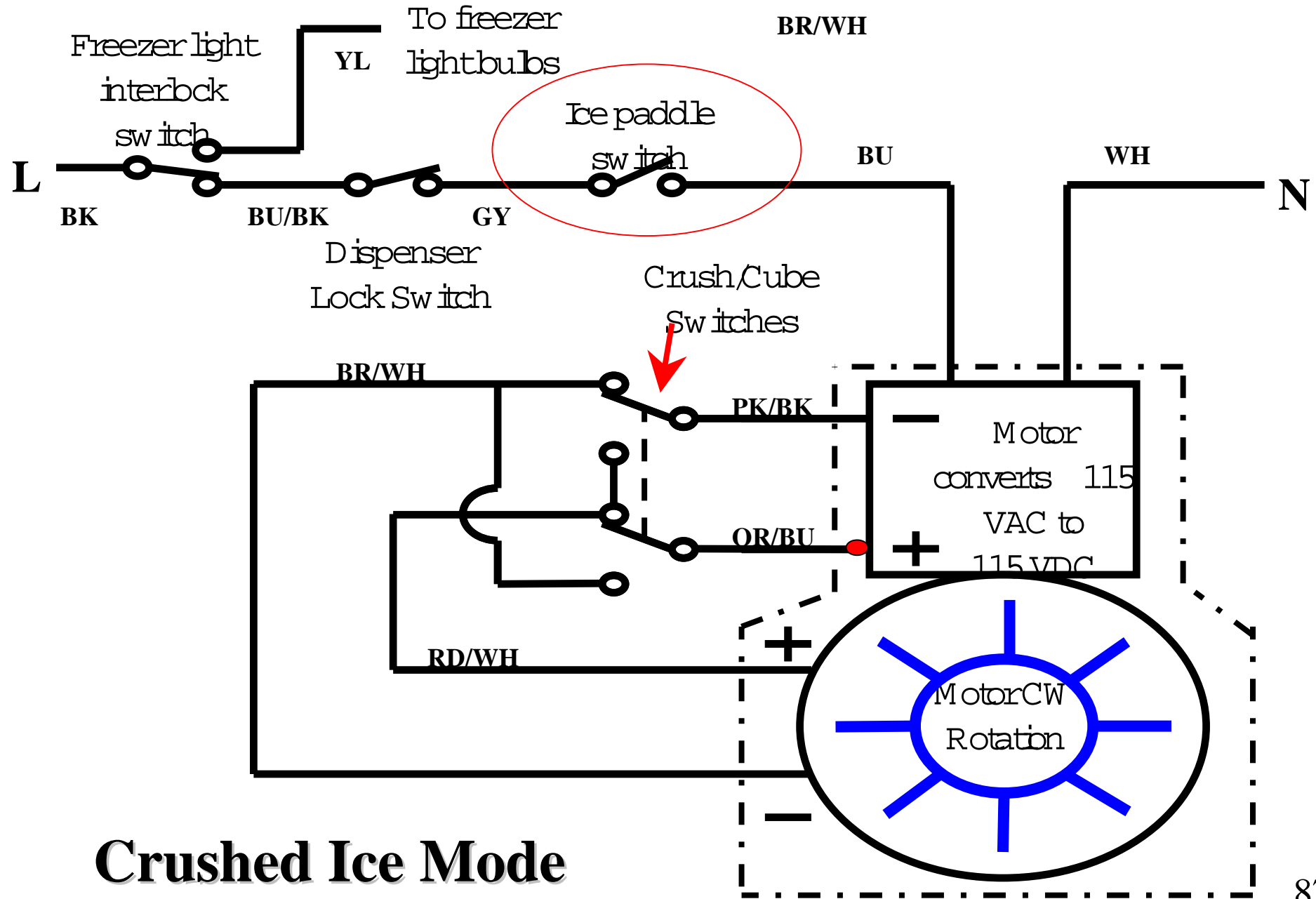

# Crushed Ice Mode



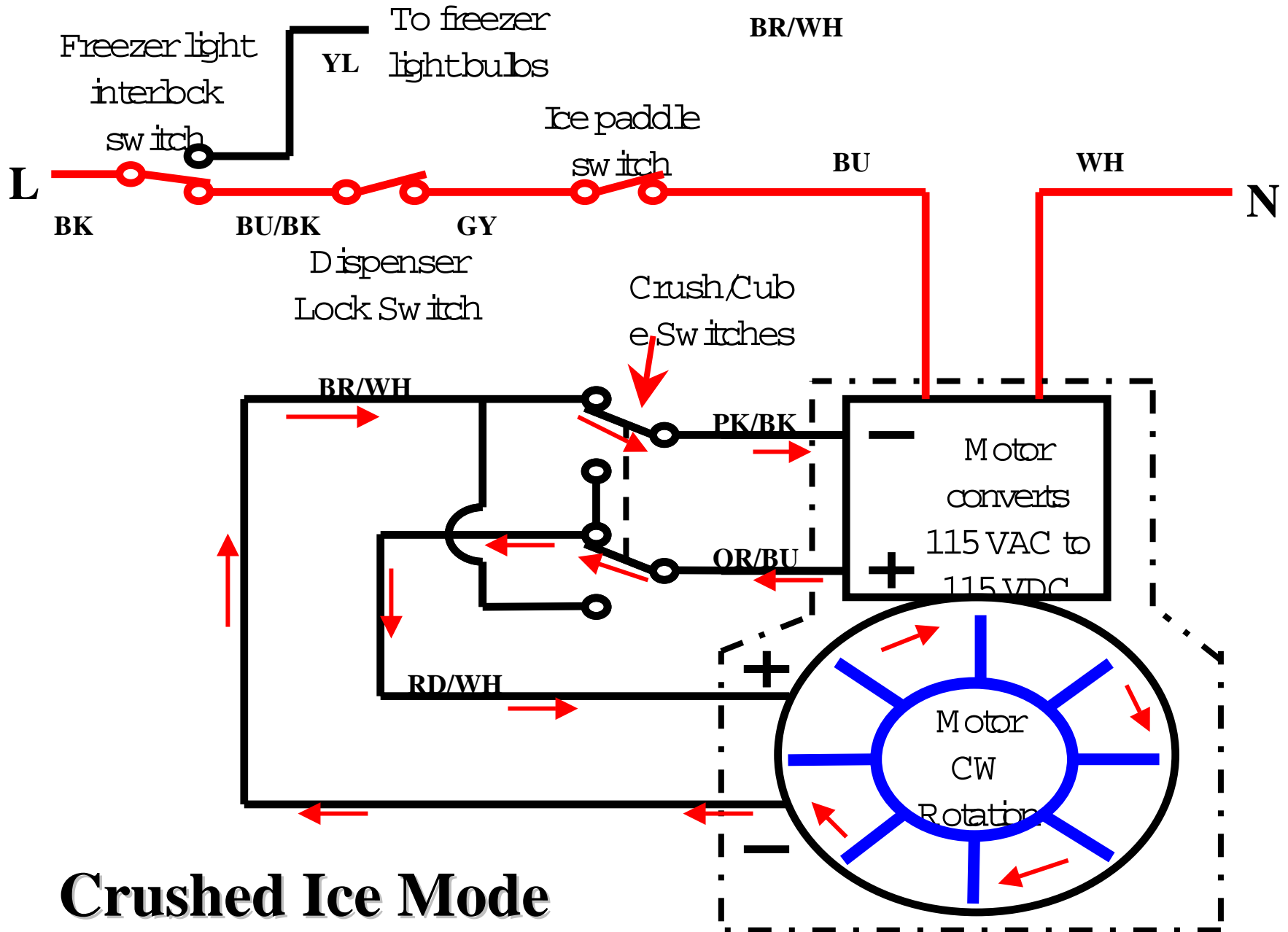

# Crushed Ice Mode

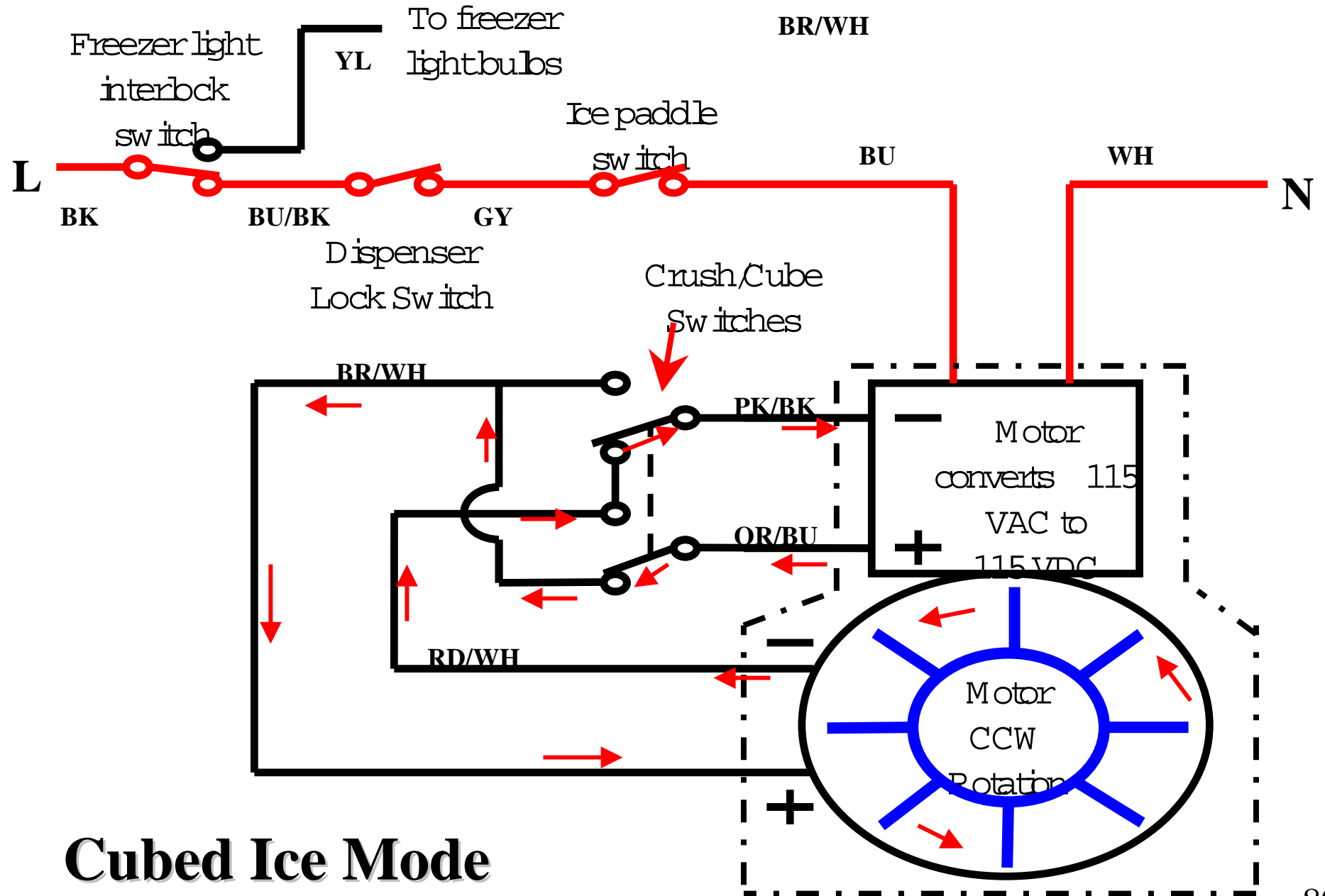

# Cubed Ice Mode

# Water Dispenser Mode

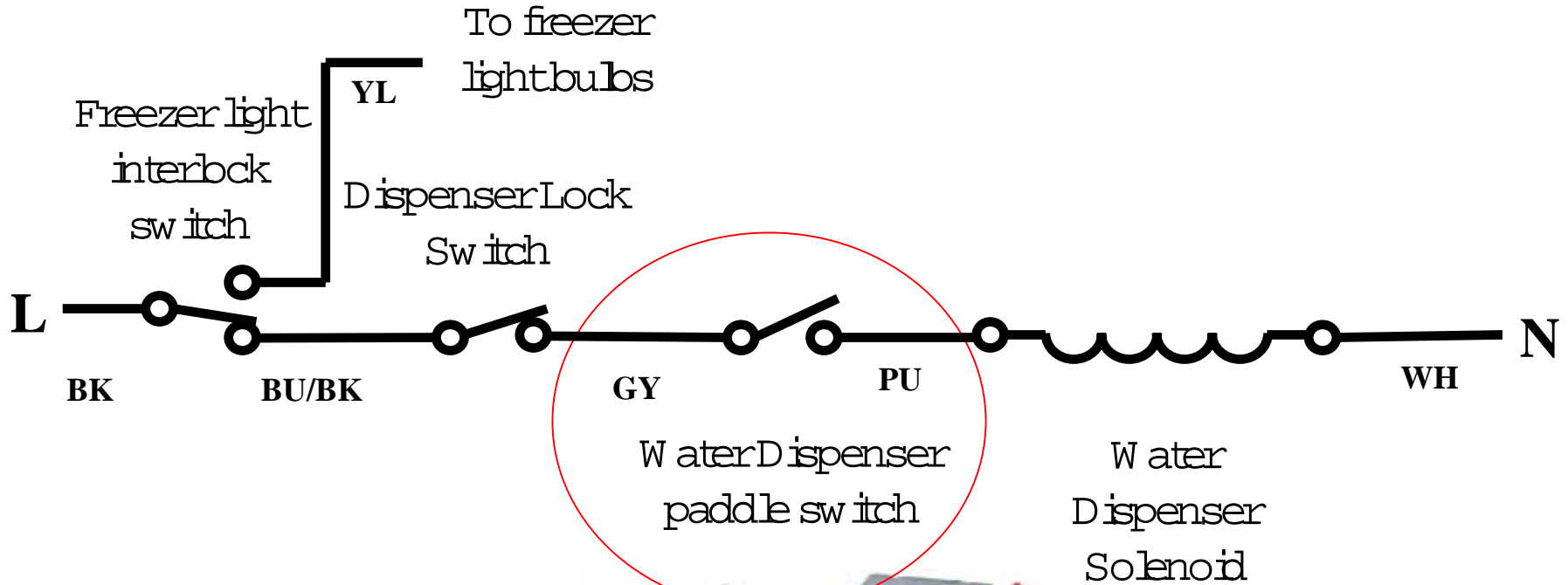

# Water Dispenser Mode

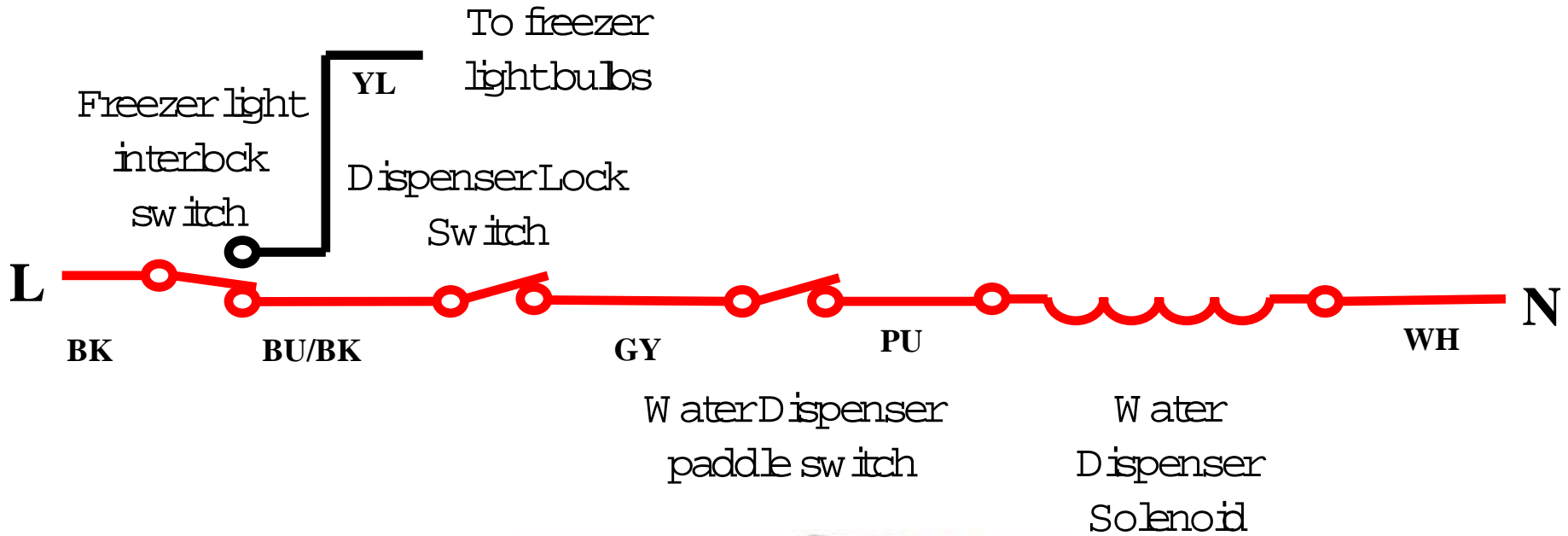

# Anti Run-On Device

## The answer to dripping dispensers

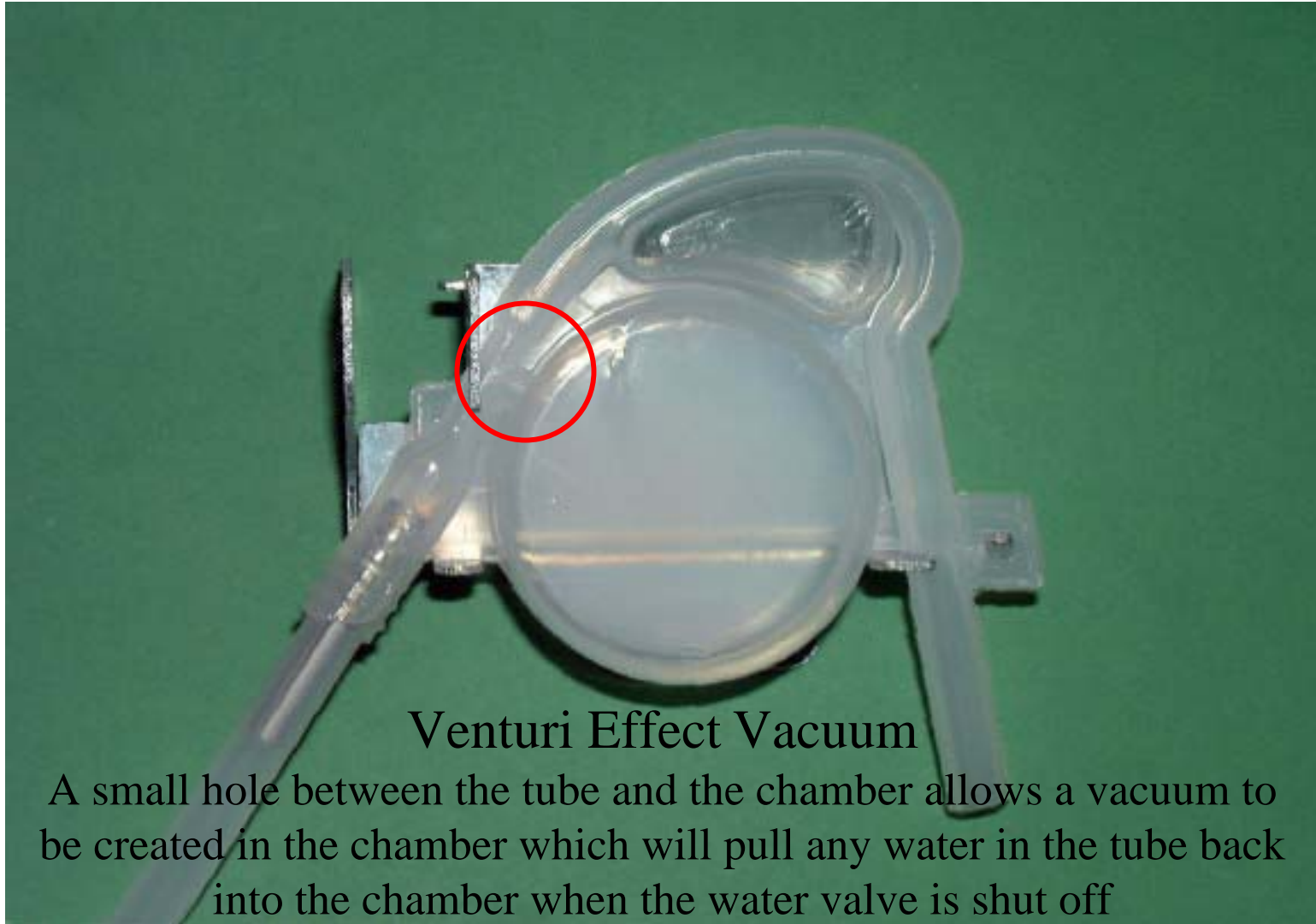

### Venturi Effect Vacuum

A small hole between the tube and the chamber allows a vacuum to be created in the chamber which will pull any water in the tube back into the chamber when the water valve is shut off



The device is mounted above the water dispenser paddle. The water is pulled back from the spout by the vacuum created by the bellows



## “Phantom” Dispenser Water Leaks



Intermittent or “Phantom” water leaks have sometimes been attributed to the **“Rover Effect”**.







## Thermador Refrigerator Review

1. What width's do Thermador Refrigerators come in?
2. In the Model Number what does the letter A stand for?
3. What controls both Cooling and Defrost functions?
4. Does the Bottom Freezer have a Door or a Drawer?
5. How much total weight will the 48" Refrigerator Door hold?
6. What are the numbers of years for the following warranties?  
All Parts and Labor  
Sealed System - Parts and Labor  
Sealed System - Parts Only

7. Where is the Model and Serial number located?
8. Should a service tech check for an Anti Tip Device?
9. Where are the leg adjusters located?
10. What are the Door Opening Swing Settings?
11. Can the doors be adjusted vertically or horizontally?
12. What happens if the Factory Test Jumper is left on the control board?
13. What is the temperature setting range for the Refrigerator?
14. What is the temperature setting range for the Freezer?
15. How do you put the main control into Diagnostic Mode?



16. Is the Defrost Heater on 100% of the time during the defrost cycle?
17. Is the Evaporator Fan a variable speed motor?
18. What is the purpose of the motorized air door?
19. What senses the compartment temperatures?
20. What kind of Compressor does the New Thermador refrigerator use?
21. Should the refrigerator be moved to change the water filter?
22. Is the water valve before the water filter or after the filter?
23. How long is the fill tube Heated during/after the ice harvest?

24. How does the refrigerator know if the Ice Bucket is in place?
25. Does the front dispenser panel need to be removed to access the Ice Bucket Drive Motor?
26. Do the ice bucket couplings have to be pre-aligned before installing the ice bucket?
27. Which points are jumped to manually start the Ice Maker?
28. What Voltages are present at the Dispenser Switch Pack?
29. How does the bucket drive motor switch directions?
30. What is an unusual way that water may be found on the floor?

# Thermador Refrigerator Review

1. What width's do Thermador Refrigerators come in? **36", 42", 48"**
2. In the Model Number what does the letter A stand for? **Year of Manufacture**
3. What controls both Cooling and Defrost functions? **Electronic Control Board**
4. Does the Bottom Freezer have a Door or a Drawer? **Slide Out Drawer  
W/2 Baskets**
5. How much total weight will the 48" Refrigerator Door hold? **70 lbs.**
6. What are the numbers of years for the following warranties?  
All Parts and Labor **2 years**  
Sealed System - Parts and Labor **6 years**  
Sealed System - Parts Only **12 years**

7. Where is the Model and Serial number located? **Inside Top Right Corner**
8. Should a service tech check for an Anti Tip Device? **Yes**
9. Where are the leg adjusters located? **Bottom Front Corners Under Hinges**
10. What are the Door Opening Swing Settings? **90, 110, 130 degrees**
11. Can the doors be adjusted vertically or horizontally? **Both**
12. What happens is the Factory Test Jumper is left on the control board?  
**Unit goes through a 20 second test then runs normally**
13. What is the temperature setting range for the Refrigerator? **34F to 46F**
14. What is the temperature setting range for the Freezer? **-5F to 6F**
15. How do you put the main control into Diagnostic Mode?  
**Press Reset and while holding press the On/Off Button for 3 Sec**

16. Is the Defrost Heater on 100% of the time during the defrost cycle?  
**It cycles - 2 minutes ON, 1 minute OFF until limiter opens**
17. Is the Evaporator Fan a variable speed motor? **No, It's a single speed AC motor**
18. What is the purpose of the motorized air door?  
**It controls cold air flow to the Fresh Food Compartment**
19. What senses the compartment temperatures?  
**Thermistors in the Freezer and Ref Compartments**
20. What kind of Compressor does the New Thermador refrigerator use?  
**Piston / Reciprocating**
21. Should the refrigerator be moved to change the water filter? **No**
22. Is the water valve before the water filter or after the filter? **After the Water Filter**
23. How long is the fill tube Heated during/after the ice harvest? **90 Minutes**

24. How does the refrigerator know if the Ice Bucket is in place?  
**I.R. Light Beam is blocked by the Emitter Door**
25. Does the front dispenser panel need to be removed to access the Ice Bucket Drive Motor?  
**No – Accessed from Inner Door**
26. Do the ice bucket couplings have to be pre-aligned before installing the ice bucket?  
**No – They self align when the dispenser is activated**
27. Which points are jumped to manually start the Ice Maker? **T & H**
28. What Voltages are present at the Dispenser Switch Pack?  
**115 volts AC & 115 volts DC**
29. How does the bucket drive motor switch directions?  
**By switching the DC current flow via the Cubed / Crushed dispenser buttons**
30. What is an unusual way that water may be found on the floor?  
**The Rover Effect**