

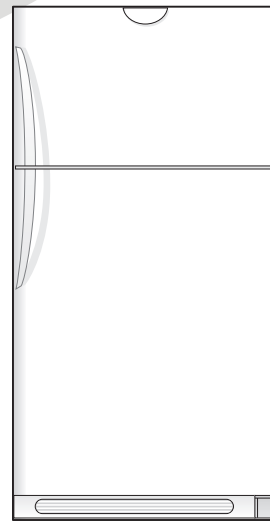

Product Information and Technical Guide

*Side by Side and Top Mount Refrigerators
January 2005 - June 2005*

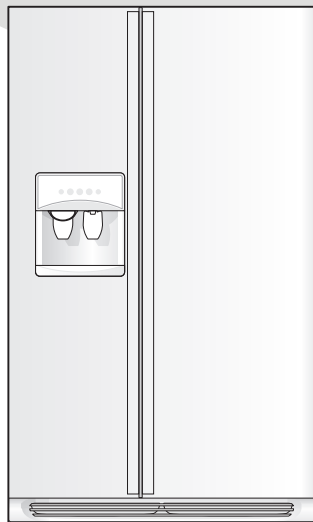

Frigidaire

TAPPAN[®]

Gibson[®]

W White-Westinghouse[®]

TABLE OF CONTENTS

Safe Servicing Practices	2
Service Data Sheet, Refrigerant Charge & Energy Efficiency Rating Indexes	3 - 17
Troubleshooting Guide	18- 22

Appendix A - Service Data Sheets

240379005	A1 - A2
240379011	A3 - A4
240379014	A5 - A6
240379015	A7 - A8
240389604	A9 - A10
240389616	A11 - A12
240389618	A13 - A14
240389620	A15 - A16
240389621	A17 - A18
240389622	A19 - A20
240389623	A21 - A22
240389624	A23 - A24
241532603	A25 - A26
241588200	A27 - A28
241588201	A29 - A30
241636600	A31 - A32
241636601	A33 - A34
241639000	A35 - A36
241643300	A37 - A38
241643400	A39 - A40

SAFE SERVICING PRACTICES - ALL APPLIANCES

To avoid personal injury and/or property damage, it is important that **Safe Servicing Practices** be observed. The following are some limited examples of safe practices:

1. **DO NOT** attempt a product repair if you have any doubts as to your ability to complete it in a safe and satisfactory manner.
2. Before servicing or moving an appliance:
 - Remove the power cord from the electrical outlet, trip the circuit breaker to the OFF position, or remove the fuse.
 - Turn off the gas supply.
 - Turn off the water supply.
3. Never interfere with the proper operation of any safety device.
4. **USE ONLY REPLACEMENT PARTS CATALOGED FOR THIS APPLIANCE. SUBSTITUTIONS MAY DEFEAT COMPLIANCE WITH SAFETY STANDARDS SET FOR HOME APPLIANCES.**
5. **GROUNDING:** The standard color coding for safety ground wires is **GREEN**, or **GREEN with YELLOW STRIPES**. Ground leads are not to be used as current carrying conductors. It is **EXTREMELY** important that the service technician reestablish all safety grounds prior to completion of service. Failure to do so will create a hazard.
6. Prior to returning the product to service, ensure that:
 - All electrical connections are correct and secure
 - All electrical leads are properly dressed and secured away from sharp edges, high-temperature components, and moving parts
 - All non-insulated electrical terminals, connectors, heaters, etc. are adequately spaced away from all metal parts and panels
 - All safety grounds (both internal and external) are correctly and securely connected
 - All panels are properly and securely reassembled

ATTENTION!!!

This service manual is intended for use by persons having electrical and mechanical training and a level of knowledge of these subjects generally considered acceptable in the appliance repair trade. Electrolux Home Products, Inc. cannot be responsible, nor assume any liability, for injury or damage of any kind arising from the use of this manual.

Model	Service Data Sheet	Charge (oz.)	Energy Efficiency Rating (KWH / Year)	Brand
CRTE151AQ1	240379011	4.5	443	Crosley
CRTE151AQ2	240379015	4.5	443	Crosley
CRTE151AW1	240379011	4.5	443	Crosley
CRTE151AW2	240379015	4.5	443	Crosley
CRTE151AW3	240379015	4.5	443	Crosley
CRTE171AQ1	240379011	4.5	460	Crosley
CRTE171AQ2	240379015	4.5	460	Crosley
CRTE171AW1	240379011	4.5	460	Crosley
CRTE171AW2	240379015	4.5	460	Crosley
CRTE183AQ8	240379015	4.25	479	Crosley
CRTE183AQA	240379015	4.25	479	Crosley
CRTE183AW8	240379015	4.25	479	Crosley
CRTE183AWA	240379015	4.25	479	Crosley
CRTE183AWB	240379015	4.25	479	Crosley
CRTE187AS2	240379015	4.25	407	Crosley
CRTE187AS4	240379015	4.25	407	Crosley
CRTE187ES0	240379015	4.25	407	Crosley
CRTE187EW0	240379015	4.25	407	Crosley
E23CS75DSS3	241532603	5.75	687	Electrolux
E23CS75DSS5	241532603	5.75	687	Electrolux
E23CS75DSS7	241532603	5.75	687	Electrolux
E23CS78DSS1	241532603	6	584	Electrolux
E23CS78DSS3	241532603	6	584	Electrolux
E23CS78EPS1	241639000	6	584	Electrolux
E23CS78ESS1	241639000	6	584	Electrolux
FLSC238DB3	241532603	6	584	Frigidaire
FLSC238DS4	241532603	6	584	Frigidaire
FLSC238DS5	241532603	6	584	Frigidaire
FLSC238DS7	241532603	6	584	Frigidaire
FLSC238DS9	241532603	6	584	Frigidaire
FLSC23F6DB3	241532603	6	584	Frigidaire
FLSC23F6DB5	241532603	6	584	Frigidaire
FLSC23F6DS5	241532603	6	584	Frigidaire
FLSC23F6DS7	241532603	6	584	Frigidaire
FRS23F4DQ4	240389621	5	686	Frigidaire
FRS23F4DW4	240389621	5	686	Frigidaire
FRS23H5DSBA	240389621	5	583	Frigidaire
FRS23KF5DB2	240389616	5	686	Frigidaire
FRS23KF5DB4	240389621	5	686	Frigidaire
FRS23KF5DQ4	240389621	5	686	Frigidaire
FRS23KF5DS4	240389621	5	686	Frigidaire
FRS23KF5DW4	240389621	5	686	Frigidaire
FRS23KF6DB8	240389621	5	583	Frigidaire
FRS23KF6DQ8	240389621	5	583	Frigidaire
FRS23KF6DW8	240389621	5	583	Frigidaire
FRS23LH5DB9	240389616	5	584	Frigidaire
FRS23LH5DQ9	240389616	5	585	Frigidaire
FRS23LH5DS9	240389616	5	587	Frigidaire
FRS23LH5DSN	240389616	5	586	Frigidaire
FRS23LH5DW9	240389616	5	588	Frigidaire
FRS23R4CB9	240389616	5	686	Frigidaire
FRS23R4CQ9	240389616	5	686	Frigidaire
FRS23R4CW9	240389616	5	686	Frigidaire
FRS23W3AQG	240389616	5	686	Frigidaire

Model	Service Data Sheet	Charge (oz.)	Energy Efficiency Rating (KWH / Year)	Brand
FRS23W3AWG	240389616	5	686	Frigidaire
FRS266ZDSB4	240389616	5.25	727	Frigidaire
FRS266ZDSB7	240389616	5.25	727	Frigidaire
FRS26BRDSB5	240389616	5.25	727	Frigidaire
FRS26BRDSB7	240389616	5.25	727	Frigidaire
FRS26BRDSB9	240389616	5.25	727	Frigidaire
FRS26DR7DS6	240389616	5.25	618	Frigidaire
FRS26DR7DS7	240389616	5.25	618	Frigidaire
FRS26F4DB3	240389621	5.25	727	Frigidaire
FRS26F4DQ3	240389621	5.25	727	Frigidaire
FRS26F4DW3	240389621	5.25	727	Frigidaire
FRS26F4DW5	240389621	5.25	727	Frigidaire
FRS26H5DSB5	240389621	5.25	618	Frigidaire
FRS26HR4DB5	240389616	5.25	618	Frigidaire
FRS26HR4DQ5	240389616	5.25	618	Frigidaire
FRS26HR4DW5	240389616	5.25	618	Frigidaire
FRS26KF5DB3	240389621	5.25	727	Frigidaire
FRS26KF5DB5	240389621	5.25	727	Frigidaire
FRS26KF5DW5	240389621	5.25	727	Frigidaire
FRS26KF6DB5	240389621	5.25	618	Frigidaire
FRS26KF6DQ5	240389621	5.25	618	Frigidaire
FRS26KF6DW5	240389621	5.25	618	Frigidaire
FRS26KR4DB6	240389616	5.25	727	Frigidaire
FRS26KR4DB7	240389616	5.25	727	Frigidaire
FRS26KR4DQ6	240389616	5.25	727	Frigidaire
FRS26KR4DQ7	240389616	5.25	727	Frigidaire
FRS26KR4DS6	240389616	5.25	727	Frigidaire
FRS26KR4DW6	240389616	5.25	727	Frigidaire
FRS26KR4DW7	240389616	5.25	727	Frigidaire
FRS26LF7DS6	240389616	5.25	618	Frigidaire
FRS26LF7DS7	240389616	5.25	618	Frigidaire
FRS26LF7DS9	240389616	5.25	618	Frigidaire
FRS26LF7DSN	240389616	5.25	618	Frigidaire
FRS26LF8CS9	240389616	5.25	618	Frigidaire
FRS26LF8CSN	240389616	5.25	618	Frigidaire
FRS26LF8CW4	240389616	5.25	618	Frigidaire
FRS26LH5DB7	240389616	5.25	618	Frigidaire
FRS26LH5DQ7	240389616	5.25	618	Frigidaire
FRS26LH5DS9	240389616	5.25	618	Frigidaire
FRS26R2AQ1	240389604	5.25	727	Frigidaire
FRS26R2AW1	240389604	5.25	727	Frigidaire
FRS26R4CBE	240389616	5.25	727	Frigidaire
FRS26R4CQE	240389616	5.25	727	Frigidaire
FRS26R4CWE	240389616	5.25	727	Frigidaire
FRS26RBCWA	240389616	5.25	727	Frigidaire
FRS26RLECSG	240389616	5.25	727	Frigidaire
FRS26RLECSN	240389616	5.25	727	Frigidaire
FRS26RLECSP	240389616	5.25	727	Frigidaire
FRS26RLECSR	240389616	5.25	727	Frigidaire
FRS26TS6DW5	240389621	5.25	618	Frigidaire
FRS26TS7DB3	240389621	5.25	618	Frigidaire
FRS26TS7DB5	240389621	5.25	618	Frigidaire
FRS26TS7DW5	240389621	5.25	618	Frigidaire
FRS26W2AWG	240389621	5.25	727	Frigidaire

Model	Service Data Sheet	Charge (oz.)	Energy Efficiency Rating (KWH / Year)	Brand
FRS3R3EW1	240389616	5	686	Frigidaire
FRS3R4EB0	240389616	5	686	Frigidaire
FRS3R4EMB0	240389616	5	686	Frigidaire
FRS3R4EQ0	240389616	5	686	Frigidaire
FRS3R4EW0	240389616	5	686	Frigidaire
FRS6B5EEQ1	240389622	5.25	727	Frigidaire
FRS6B5EEQ3	240389624	5.25	727	Frigidaire
FRS6B5EEW1	240389622	5.25	727	Frigidaire
FRS6B5EEW3	240389624	5.25	727	Frigidaire
FRS6B6EEB1	240389620	5.25	727	Frigidaire
FRS6B6EEB3	240389623	5.25	727	Frigidaire
FRS6B6EEW1	240389620	5.25	727	Frigidaire
FRS6B6EEW3	240389623	5.25	727	Frigidaire
FRS6B7EESB1	241636600	5.25	618	Frigidaire
FRS6B7EESB5	241636600	5.25	618	Frigidaire
FRS6L7EES1	240389622	5.25	618	Frigidaire
FRS6L9EES1	241636600	5.25	618	Frigidaire
FRS6L9EES3	241636600	5.25	618	Frigidaire
FRS6R3EB0	240389616	5.25	727	Frigidaire
FRS6R3EB1	240389616	5.25	727	Frigidaire
FRS6R3EQ0	240389616	5.25	727	Frigidaire
FRS6R3EW0	240389616	5.25	727	Frigidaire
FRS6R3EW1	240389616	5.25	727	Frigidaire
FRS6R3EW1	240389616	5.25	727	Frigidaire
FRS6R3EW3	240389616	5.25	727	Frigidaire
FRS6R5EMB1	240389616	5.25	727	Frigidaire
FRS6R5EMB3	240389616	5.25	727	Frigidaire
FRT15A2DW0	240379015	4.5	443	Frigidaire
FRT15A2DW1	240379015	4.5	443	Frigidaire
FRT15A2DW2	240379015	4.5	443	Frigidaire
FRT15A2DZ0	240379015	4.5	443	Frigidaire
FRT15A2DZ1	240379015	4.5	443	Frigidaire
FRT15A2DZ2	240379015	4.5	443	Frigidaire
FRT15B1BW2	240379015	4.5	443	Frigidaire
FRT15B3AQ5	240379015	4.5	443	Frigidaire
FRT15B3AQ6	240379015	4.5	443	Frigidaire
FRT15B3AQ7	240379015	4.5	443	Frigidaire
FRT15B3AW5	240379015	4.5	443	Frigidaire
FRT15B3AW6	240379015	4.5	443	Frigidaire
FRT15B3AW7	240379015	4.5	443	Frigidaire
FRT15B3AZ5	240379015	4.5	443	Frigidaire
FRT15B3AZ6	240379015	4.5	443	Frigidaire
FRT15B3AZ7	240379015	4.5	443	Frigidaire
FRT15G4BQ3	240379015	4.5	443	Frigidaire
FRT15G4BQ4	240379015	4.5	443	Frigidaire
FRT15G4BQ5	240379015	4.5	443	Frigidaire
FRT15G4BW3	240379015	4.5	443	Frigidaire
FRT15G4BW4	240379015	4.5	443	Frigidaire
FRT15G4BW5	240379015	4.5	443	Frigidaire
FRT15G5CSB3	240379015	4.25	443	Frigidaire
FRT15G5CSB4	240379015	4.25	443	Frigidaire
FRT15G5CSK3	240379015	4.25	443	Frigidaire
FRT15HB3DQ1	240379015	4.25	376	Frigidaire
FRT15HB3DQ2	240379015	4.25	376	Frigidaire

Model	Service Data Sheet	Charge (oz.)	Energy Efficiency Rating (KWH / Year)	Brand
FRT15HB3DW1	240379015	4.25	376	Frigidaire
FRT15HB3DW2	240379015	4.25	376	Frigidaire
FRT15HB3DW3	240379015	4.25	376	Frigidaire
FRT15HB3DZ1	240379015	4.25	376	Frigidaire
FRT15HB3DZ2	240379015	4.25	376	Frigidaire
FRT15HB3DZ3	240379015	4.25	376	Frigidaire
FRT15MB3AW0	240379015	4.5	443	Frigidaire
FRT17A2AW4	240379011	4.5	460	Frigidaire
FRT17A2AZ4	240379011	4.5	460	Frigidaire
FRT17B3AQ5	240379011	4.5	460	Frigidaire
FRT17B3AQ6	240379015	4.5	460	Frigidaire
FRT17B3AW5	240379011	4.5	460	Frigidaire
FRT17B3AW6	240379015	4.5	460	Frigidaire
FRT17B3AZ5	240379011	4.5	460	Frigidaire
FRT17B3AZ6	240379015	4.5	460	Frigidaire
FRT17B3AZ7	240379015	4.5	460	Frigidaire
FRT17G4BQ3	240379011	4.5	460	Frigidaire
FRT17G4BQ4	240379015	4.5	460	Frigidaire
FRT17G4BW3	240379011	4.5	460	Frigidaire
FRT17G4BW4	240379015	4.5	460	Frigidaire
FRT17G4BW5	240379015	4.5	460	Frigidaire
FRT17G5CSB3	240379015	4.25	460	Frigidaire
FRT17G5CSB4	240379015	4.25	460	Frigidaire
FRT17G5CSB5	240379015	4.25	460	Frigidaire
FRT17G5CSB6	240379015	4.25	460	Frigidaire
FRT17G5CSK3	240379015	4.25	460	Frigidaire
FRT17G5CSK4	240379015	4.25	460	Frigidaire
FRT17G5CSK5	240379015	4.25	460	Frigidaire
FRT17G5CSK6	240379015	4.25	460	Frigidaire
FRT17IB3AW5	240379015	4.5	460	Frigidaire
FRT17IB3AW6	240379015	4.5	460	Frigidaire
FRT17IB3AW7	240379015	4.5	460	Frigidaire
FRT17IB3AZ5	240379015	4.5	460	Frigidaire
FRT17IB3AZ7	240379015	4.5	460	Frigidaire
FRT18B1BW4	240379015	4.5	479	Frigidaire
FRT18B4AQA	240379015	4.5	479	Frigidaire
FRT18B4AWA	240379015	4.5	479	Frigidaire
FRT18B4AZA	240379015	4.5	479	Frigidaire
FRT18B5ABC	240379014	4.25	479	Frigidaire
FRT18B5AW6	240379015	4.5	479	Frigidaire
FRT18B5AWC	240379014	4.25	479	Frigidaire
FRT18FP5DK0	240379015	4.5	479	Frigidaire
FRT18FP5DQ0	240379015	4.5	479	Frigidaire
FRT18FP5DQ4	240379015	4.5	479	Frigidaire
FRT18FP5DW0	240379015	4.5	479	Frigidaire
FRT18FP5DW4	240379015	4.5	479	Frigidaire
FRT18FR7EB2	241643300	4.25	407	Frigidaire
FRT18FR7EB4	240379015	4.25	407	Frigidaire
FRT18FR7EQ0	241643300	4.25	407	Frigidaire
FRT18FR7EQ2	241643300	4.25	407	Frigidaire
FRT18FR7EW0	241643300	4.25	407	Frigidaire
FRT18FR7EW2	241643300	4.25	407	Frigidaire
FRT18G4AQC	240379011	4.5	479	Frigidaire
FRT18G4AQD	240379015	4.5	479	Frigidaire

Model	Service Data Sheet	Charge (oz.)	Energy Efficiency Rating (KWH / Year)	Brand
FRT18G4AQE	240379015	4.5	479	Frigidaire
FRT18G4AWC	240379011	4.5	479	Frigidaire
FRT18G4AWD	240379015	4.5	479	Frigidaire
FRT18G4AWE	240379015	4.5	479	Frigidaire
FRT18G4AWH	240379015	4.25	479	Frigidaire
FRT18G7CW4	240379015	4.5	479	Frigidaire
FRT18G7CW6	240379015	4.5	479	Frigidaire
FRT18G7CW8	240379015	4.5	479	Frigidaire
FRT18HB5DW0	240379015	4.25	407	Frigidaire
FRT18HB5DW2	240379015	4.25	407	Frigidaire
FRT18HB5DW4	240379015	4.25	407	Frigidaire
FRT18HP7DB0	240379015	4.25	407	Frigidaire
FRT18HP7DB2	240379015	4.25	407	Frigidaire
FRT18HP7DW0	240379015	4.25	407	Frigidaire
FRT18HP7DW2	240379015	4.25	407	Frigidaire
FRT18HS6DB2	240379015	4.25	407	Frigidaire
FRT18HS6DB5	240379014	4.25	407	Frigidaire
FRT18HS6DQ0	240379015	4.25	407	Frigidaire
FRT18HS6DQ2	240379015	4.25	407	Frigidaire
FRT18HS6DW0	240379015	4.25	407	Frigidaire
FRT18HS6DW2	240379015	4.25	407	Frigidaire
FRT18HS6DW4	240379015	4.25	407	Frigidaire
FRT18IB4AWA	240379015	4.5	479	Frigidaire
FRT18IG4AQA	240379015	4.5	479	Frigidaire
FRT18IG4ATA	240379015	4.5	479	Frigidaire
FRT18IG4AWA	240379015	4.5	479	Frigidaire
FRT18IG4AZA	240379015	4.5	479	Frigidaire
FRT18IL6DB3	240379014	4.25	479	Frigidaire
FRT18IL6DBA	241643300	4.25	479	Frigidaire
FRT18IL6DBB	240379015	4.25	479	Frigidaire
FRT18IL6DBC	240379015	4.25	479	Frigidaire
FRT18IL6DK6	240379015	4.25	479	Frigidaire
FRT18IL6DKA	241643300	4.25	479	Frigidaire
FRT18IL6DKB	240379015	4.25	479	Frigidaire
FRT18IL6DKC	240379015	4.25	479	Frigidaire
FRT18IL6DQ8	240379015	4.25	479	Frigidaire
FRT18IL6DQA	241643300	4.25	479	Frigidaire
FRT18IL6DQB	240379015	4.25	479	Frigidaire
FRT18IL6DQC	240379015	4.25	479	Frigidaire
FRT18IL6DS6	240379015	4.25	479	Frigidaire
FRT18IL6DSA	241643300	4.25	479	Frigidaire
FRT18IL6DSB	240379015	4.25	479	Frigidaire
FRT18IL6DSC	240379015	4.25	479	Frigidaire
FRT18IL6DW8	240379015	4.25	479	Frigidaire
FRT18IL6DWA	241643300	4.25	479	Frigidaire
FRT18IL6DWB	240379015	4.25	479	Frigidaire
FRT18IL6DWC	240379015	4.25	479	Frigidaire
FRT18IS6CB3	240379014	4.25	479	Frigidaire
FRT18IS6CBC	240379015	4.25	479	Frigidaire
FRT18IS6CBD	240379015	4.25	479	Frigidaire
FRT18IS6CQB	241643300	4.25	479	Frigidaire
FRT18IS6CQC	240379015	4.25	479	Frigidaire
FRT18IS6CWA	240379015	4.25	479	Frigidaire
FRT18IS6CWB	241643300	4.25	479	Frigidaire

Model	Service Data Sheet	Charge (oz.)	Energy Efficiency Rating (KWH / Year)	Brand
FRT18IS6CWC	240379015	4.25	479	Frigidaire
FRT18IS6CWD	240379015	4.25	479	Frigidaire
FRT18KB2DW0	240379015	4.5	479	Frigidaire
FRT18KB2DW2	240379015	4.5	479	Frigidaire
FRT18KB2DW4	240379015	4.5	479	Frigidaire
FRT18KG3DW0	240379015	4.5	479	Frigidaire
FRT18KG3DW2	240379015	4.5	479	Frigidaire
FRT18KG3DW4	240379015	4.5	479	Frigidaire
FRT18KG4DW0	240379015	4.5	479	Frigidaire
FRT18KG4DW2	240379015	4.5	479	Frigidaire
FRT18KG4DW4	240379015	4.5	479	Frigidaire
FRT18KP5DQ0	240379015	4.5	479	Frigidaire
FRT18KP5DW0	240379015	4.5	479	Frigidaire
FRT18KR7EB2	240379015	4.25	407	Frigidaire
FRT18KR7EQ2	240379015	4.25	407	Frigidaire
FRT18KR7EW0	240379015	4.25	407	Frigidaire
FRT18KR7EW2	240379015	4.25	407	Frigidaire
FRT18KR7EW4	240379015	4.25	407	Frigidaire
FRT18P6BSB4	240379015	4.25	479	Frigidaire
FRT18P6BSB6	240379015	4.25	479	Frigidaire
FRT18P6BSK4	240379015	4.25	479	Frigidaire
FRT18P6BSK6	240379015	4.25	479	Frigidaire
FRT18S6ABH	240379015	4.25	479	Frigidaire
FRT18S6ABJ	240379015	4.25	479	Frigidaire
FRT18S6AQH	240379015	4.25	479	Frigidaire
FRT18S6AQJ	240379015	4.25	479	Frigidaire
FRT18S6AWH	240379015	4.25	479	Frigidaire
FRT18S6AWJ	240379015	4.25	479	Frigidaire
FRT18S6AWK	240379015	4.25	479	Frigidaire
FRT1S6ESB1	240379014	4.25	509	Frigidaire
FRT1S6ESB3	240379014	4.25	509	Frigidaire
FRT1S6ESB5	240379014	4.25	509	Frigidaire
FRT1S6ESK1	240379014	4.25	509	Frigidaire
FRT1S6ESK3	240379014	4.25	509	Frigidaire
FRT1S6ESK5	240379014	4.25	509	Frigidaire
FRT21BH8DW3	241588200	4.25	432	Frigidaire
FRT21BSDSB5	241588200	4.25	432	Frigidaire
FRT21BSDSB7	241588200	4.25	432	Frigidaire
FRT21BSDSK5	241588200	4.25	432	Frigidaire
FRT21BSDSK7	241588200	4.25	432	Frigidaire
FRT21BW8DB1	241588200	4.25	432	Frigidaire
FRT21BW8DB3	241588200	4.25	432	Frigidaire
FRT21FG3DQ6	240379014	4.25	432	Frigidaire
FRT21FG3DW6	240379014	4.25	509	Frigidaire
FRT21FR7EB1	240379014	4.25	432	Frigidaire
FRT21FR7EB3	240379014	4.25	432	Frigidaire
FRT21FR7EQ1	240379014	4.25	432	Frigidaire
FRT21FR7EQ3	240379014	4.25	432	Frigidaire
FRT21FR7EW1	240379014	4.25	432	Frigidaire
FRT21FR7EW3	240379014	4.25	432	Frigidaire
FRT21FS6DQ2	240379014	4.25	509	Frigidaire
FRT21FS6DW2	240379014	4.25	509	Frigidaire
FRT21FS6DW3	241643300	4.25	509	Frigidaire
FRT21G3CWA	240379014	4.25	509	Frigidaire

Model	Service Data Sheet	Charge (oz.)	Energy Efficiency Rating (KWH / Year)	Brand
FRT21G4BWC	240279014	4.25	509	Frigidaire
FRT21HC5DW5	240279014	4.25	432	Frigidaire
FRT21HC5DW7	240379014	4.25	432	Frigidaire
FRT21HS6DB3	240379014	4.25	432	Frigidaire
FRT21HS6DB5	240379014	4.25	432	Frigidaire
FRT21HS6DQ5	240379014	4.25	432	Frigidaire
FRT21HS6DQ7	240379014	4.25	432	Frigidaire
FRT21HS6DW3	240379014	4.25	432	Frigidaire
FRT21HS6DW5	240379014	4.25	432	Frigidaire
FRT21HS6DW7	240379014	4.25	432	Frigidaire
FRT21IL5DB8	240379014	4.25	509	Frigidaire
FRT21IL5DB9	240379014	4.25	509	Frigidaire
FRT21IL5DBN	240379014	4.25	509	Frigidaire
FRT21IL5DQ8	240379014	4.25	509	Frigidaire
FRT21IL5DQ9	241643300	4.25	509	Frigidaire
FRT21IL5DQN	240379014	4.25	509	Frigidaire
FRT21IL5DW8	240379014	4.25	509	Frigidaire
FRT21IL5DW9	241643300	4.25	509	Frigidaire
FRT21IL5DWN	240379014	4.25	509	Frigidaire
FRT21IS6BBN	240379014	4.25	509	Frigidaire
FRT21IS6BWN	240379014	4.25	509	Frigidaire
FRT21KG3DQ8	240379014	4.25	509	Frigidaire
FRT21KG3DW0	240379014	4.25	509	Frigidaire
FRT21KG3DW8	240379014	4.25	509	Frigidaire
FRT21KG4DW8	240379014	4.25	509	Frigidaire
FRT21KG4EW1	240379014	4.25	509	Frigidaire
FRT21KG4EW3	240379014	4.25	509	Frigidaire
FRT21KR7EB1	240379014	4.25	432	Frigidaire
FRT21KR7EB3	240379014	4.25	433	Frigidaire
FRT21KR7EQ1	240379014	4.25	434	Frigidaire
FRT21KR7EQ3	240379014	4.25	435	Frigidaire
FRT21KR7EW1	240379014	4.25	436	Frigidaire
FRT21KR7EW3	240379014	4.25	437	Frigidaire
FRT21KS6DQ4	240379014	4.25	509	Frigidaire
FRT21KS6DW4	240379014	4.25	509	Frigidaire
FRT21LR7ABB	240379014	4.25	432	Frigidaire
FRT21LR7ABC	240379014	4.25	432	Frigidaire
FRT21LR7ABN	240379014	4.25	432	Frigidaire
FRT21LR7ABP	240379014	4.25	432	Frigidaire
FRT21LR7ABR	240379014	4.25	432	Frigidaire
FRT21LR7AQB	240379014	4.25	432	Frigidaire
FRT21LR7AQN	240379014	4.25	432	Frigidaire
FRT21LR7AWB	240379014	4.25	432	Frigidaire
FRT21LR7AWC	240379014	4.25	432	Frigidaire
FRT21LR7AWN	240379014	4.25	432	Frigidaire
FRT21LR7AWP	240379014	4.25	432	Frigidaire
FRT21LR7AWR	240379014	4.25	432	Frigidaire
FRT21LR7DS4	240379014	4.25	432	Frigidaire
FRT21LR7DS5	240379014	4.25	432	Frigidaire
FRT21LR7DS7	241643300	4.25	432	Frigidaire
FRT21LR8DK9	240379014	4.25	432	Frigidaire
FRT21LR8DS5	240379014	4.25	432	Frigidaire
FRT21LR8DS9	240379014	4.25	432	Frigidaire
FRT21LR8DSN	240379014	4.25	432	Frigidaire

Model	Service Data Sheet	Charge (oz.)	Energy Efficiency Rating (KWH / Year)	Brand
FRT21P5AB1	240379005	4.25	509	Frigidaire
FRT21P5AQ1	240379005	4.25	509	Frigidaire
FRT21P5AW1	240379005	4.25	509	Frigidaire
FRT21P6CSBB	240379014	4.25	509	Frigidaire
FRT21P6CSKB	240379014	4.25	509	Frigidaire
FRT21S6ABA	240379014	4.25	509	Frigidaire
FRT21S6ABN	240379014	4.25	509	Frigidaire
FRT21S6AQA	240379014	4.25	509	Frigidaire
FRT21S6AQN	240379014	4.25	509	Frigidaire
FRT21S6AWA	240379014	4.25	509	Frigidaire
FRT21S6AWN	240379014	4.25	509	Frigidaire
FRT8B5EQ0	240379015	4.5	479	Frigidaire
FRT8B5EQ2	240379015	4.5	479	Frigidaire
FRT8B5EQ4	240379015	4.5	479	Frigidaire
FRT8B5EW0	240379015	4.5	479	Frigidaire
FRT8B5EW2	240379015	4.5	479	Frigidaire
FRT8B5EW4	240379015	4.5	479	Frigidaire
FRT8B5EZ0	240379015	4.5	479	Frigidaire
FRT8B5EZ2	240379015	4.5	479	Frigidaire
FRT8B5EZ4	240379015	4.5	479	Frigidaire
FRT8B6EB0	240379015	4.5	479	Frigidaire
FRT8B6EB2	240379015	4.5	479	Frigidaire
FRT8B6EB4	240379015	4.5	479	Frigidaire
FRT8IB5EQ2	241643300	4.5	479	Frigidaire
FRT8IB5EQ4	240379015	4.5	479	Frigidaire
FRT8IB5EW2	241643300	4.5	479	Frigidaire
FRT8IB5EW4	240379015	4.5	479	Frigidaire
FRT8S6ESB0	240379015	4.25	479	Frigidaire
FRT8S6ESB2	240379015	4.25	479	Frigidaire
FRT8S6ESK0	240379015	4.25	479	Frigidaire
FRT8S6ESK2	240379015	4.25	479	Frigidaire
FRT8WR6EB0	241643400	4.25	479	Frigidaire
FRT8WR6EB2	241643400	4.25	479	Frigidaire
FRT8WR6EB4	241588201	4.25	479	Frigidaire
FRT8WR6EB6	241588201	4.25	479	Frigidaire
FRT8WR6EW0	241643400	4.25	479	Frigidaire
FRT8WR6EW2	241643400	4.25	479	Frigidaire
FRT8WR6EW4	241588201	4.25	479	Frigidaire
FRT8WR6EW6	241588201	4.25	479	Frigidaire
FSC23BBDSB5	241532603	6	584	Frigidaire
FSC23F7DB2	241532603	5.75	684	Frigidaire
FSC23F7DB3	241532603	5.75	684	Frigidaire
FSC23F7DB5	241532603	5.75	684	Frigidaire
FSC23F7DSB5	241532603	5.75	684	Frigidaire
FSC23F7DSB7	241532603	5.75	684	Frigidaire
FSC23F7DSB9	241532603	5.75	684	Frigidaire
FSC23F7DSBN	241532603	5.75	684	Frigidaire
FSC23F7DW3	241532603	5.75	684	Frigidaire
FSC23F7DW5	241532603	5.75	684	Frigidaire
FSC23F7TDB5	241532603	5.75	687	Frigidaire
FSC23F7TDS3	241532603	5.75	687	Frigidaire
FSC23F7TDS5	241532603	5.75	687	Frigidaire
FSC23F7TDW5	241532603	5.75	687	Frigidaire
FSC23R5DB5	241532603	5.75	687	Frigidaire

Model	Service Data Sheet	Charge (oz.)	Energy Efficiency Rating (KWH / Year)	Brand
FSC23R5DSB5	241532603	5.75	687	Frigidaire
FSC23R5DSB7	241532603	5.75	687	Frigidaire
FSC23R5DSB9	241532603	5.75	687	Frigidaire
FSC23R5DW5	241532603	5.75	687	Frigidaire
GHSC239DB3	241532603	6	584	Frigidaire
GHSC239DB5	241532603	6	584	Frigidaire
GHSC239DW3	241532603	6	584	Frigidaire
GHSC239TDB3	241532603	6	584	Frigidaire
GHSC239TDS3	241532603	6	584	Frigidaire
GHSC39EEPB1	241639000	6	584	Frigidaire
GHSC39EEPW1	241639000	6	584	Frigidaire
GHSC39ETEB1	241639000	6	584	Frigidaire
GHSC39ETES1	241639000	6	584	Frigidaire
GHSC39ETEW1	241639000	6	584	Frigidaire
GLHS238ZDB8	240389621	5	583	Frigidaire
GLHS238ZDQ8	240389621	5	583	Frigidaire
GLHS238ZDSA	240389621	5	583	Frigidaire
GLHS238ZDW8	240389621	5	583	Frigidaire
GLHS268ZDB5	240389618	5.25	618	Frigidaire
GLHS268ZDQ5	240389618	5.25	618	Frigidaire
GLHS268ZDS6	240389618	5.25	618	Frigidaire
GLHS268ZDS7	240389618	5.25	618	Frigidaire
GLHS268ZDW5	240389618	5.25	618	Frigidaire
GLHS269ZDB7	240389618	5.25	618	Frigidaire
GLHS269ZDW7	240389618	5.25	618	Frigidaire
GLHS36EEB0	240389622	5	583	Frigidaire
GLHS36EEB1	240389624	5	583	Frigidaire
GLHS36EEPB0	240389620	5	583	Frigidaire
GLHS36EEPB1	240389623	5	583	Frigidaire
GLHS36EEPW0	240389620	5	583	Frigidaire
GLHS36EEPW1	240389623	5	583	Frigidaire
GLHS36EEQ0	240389622	5	583	Frigidaire
GLHS36EEQ1	240389624	5	583	Frigidaire
GLHS36EESB0	240389622	5	583	Frigidaire
GLHS36EESB1	240389624	5	583	Frigidaire
GLHS36EESB3	240389624	5	583	Frigidaire
GLHS36EEW0	240389622	5	583	Frigidaire
GLHS36EEW1	240389624	5	583	Frigidaire
GLHS38EEQ0	240389620	5	583	Frigidaire
GLHS38EEQ1	240389623	5	583	Frigidaire
GLHS38EESB0	240389620	5	583	Frigidaire
GLHS38EESB3	240389623	5	583	Frigidaire
GLHS38EEW0	240389620	5	583	Frigidaire
GLHS38EEW1	240389623	5	583	Frigidaire
GLHS66EEB0	240389622	5.25	618	Frigidaire
GLHS66EEB1	240389624	5.25	618	Frigidaire
GLHS66EEQ0	240389622	5.25	618	Frigidaire
GLHS66EEQ1	240389624	5.25	618	Frigidaire
GLHS66EESB0	240389622	5.25	618	Frigidaire
GLHS66EESB1	240389624	5.25	618	Frigidaire
GLHS66EEW0	240389622	5.25	618	Frigidaire
GLHS66EEW1	240389624	5.25	618	Frigidaire
GLHS67EEPB0	240389622	5.25	618	Frigidaire
GLHS67EEPB1	240389624	5.25	618	Frigidaire

Model	Service Data Sheet	Charge (oz.)	Energy Efficiency Rating (KWH / Year)	Brand
GLHS67EEPQ0	240389622	5.25	618	Frigidaire
GLHS67EEPQ1	240389624	5.25	618	Frigidaire
GLHS67EEPW0	240389622	5.25	618	Frigidaire
GLHS67EEPW1	240389624	5.25	618	Frigidaire
GLHS68EEB0	240389620	5.25	618	Frigidaire
GLHS68EEB1	240389623	5.25	618	Frigidaire
GLHS68EEPB0	240389620	5.25	618	Frigidaire
GLHS68EEPB1	240389623	5.25	618	Frigidaire
GLHS68EEPW0	240389620	5.25	618	Frigidaire
GLHS68EEPW1	240389623	5.25	618	Frigidaire
GLHS68EEQ0	240389620	5.25	618	Frigidaire
GLHS68EEQ1	240389623	5.25	618	Frigidaire
GLHS68EESB0	240389620	5.25	618	Frigidaire
GLHS68EESB5	240389623	5.25	618	Frigidaire
GLHS68EEW0	240389620	5.25	618	Frigidaire
GLHS68EEW1	240389623	5.25	618	Frigidaire
GLHS69EEPB1	241636600	5.25	618	Frigidaire
GLHS69EEPB3	241636601	5.25	618	Frigidaire
GLHS69EEPW1	241636600	5.25	618	Frigidaire
GLHS69EEPW3	241636601	5.25	618	Frigidaire
GLRS233ZDB4	240389621	5	686	Frigidaire
GLRS233ZDW5	240389621	5	686	Frigidaire
GLRS237ZDB4	240389621	5	686	Frigidaire
GLRS237ZDQ4	240389621	5	686	Frigidaire
GLRS237ZDW4	240389621	5	686	Frigidaire
GLRS263ZDB6	240389621	5.25	727	Frigidaire
GLRS263ZDQ6	240389621	5.25	727	Frigidaire
GLRS263ZDW6	240389621	5.25	727	Frigidaire
GLRS267ZDB4	240389621	5.25	727	Frigidaire
GLRS267ZDB5	240389621	5.25	727	Frigidaire
GLRS267ZDQ4	240389621	5.25	727	Frigidaire
GLRS267ZDQ5	240389621	5.25	727	Frigidaire
GLRS267ZDW4	240389621	5.25	727	Frigidaire
GLRS267ZDW5	240389621	5.25	727	Frigidaire
GLRS64ZEB0	240389616	5.25	727	Frigidaire
GLRS64ZEB1	240389616	5.25	727	Frigidaire
GLRS64ZEQ0	240389616	5.25	727	Frigidaire
GLRS64ZEQ1	240389616	5.25	727	Frigidaire
GLRS64ZEW0	240389616	5.25	727	Frigidaire
GLRS64ZEW1	240389616	5.25	727	Frigidaire
GLRT13TEB0	240379014	4.25	509	Frigidaire
GLRT13TEB1	240379014	4.25	509	Frigidaire
GLRT13TEK0	240379014	4.25	509	Frigidaire
GLRT13TEK1	240379014	4.25	509	Frigidaire
GLRT13TEQ0	240379014	4.25	509	Frigidaire
GLRT13TEQ1	240379014	4.25	509	Frigidaire
GLRT13TES0	240379014	4.25	509	Frigidaire
GLRT13TES1	240379014	4.25	509	Frigidaire
GLRT13TEW0	240379014	4.25	509	Frigidaire
GLRT13TEW1	240379014	4.25	509	Frigidaire
GLRT183TDB5	240379014	4.25	479	Frigidaire
GLRT183TDBA	240379015	4.25	479	Frigidaire
GLRT183TDQ8	240379015	4.25	479	Frigidaire
GLRT183TDQA	240379015	4.25	479	Frigidaire

Model	Service Data Sheet	Charge (oz.)	Energy Efficiency Rating (KWH / Year)	Brand
GLRT183TDQB	240379015	4.25	479	Frigidaire
GLRT183TDW8	240379015	4.25	479	Frigidaire
GLRT183TDWA	240379015	4.25	479	Frigidaire
GLRT183TDWB	240379015	4.25	479	Frigidaire
GLRT184TCB9	240379014	4.25	479	Frigidaire
GLRT184TCQA	240379015	4.25	479	Frigidaire
GLRT184TCWA	240379015	4.25	479	Frigidaire
GLRT185TDB5	240379014	4.25	479	Frigidaire
GLRT185TDK6	240379015	4.25	479	Frigidaire
GLRT185TDQ8	240379015	4.25	479	Frigidaire
GLRT185TDS6	240379015	4.25	479	Frigidaire
GLRT185TDW8	240379015	4.25	479	Frigidaire
GLRT188WDB2	241643400	4.25	479	Frigidaire
GLRT188WDB3	241588200	4.25	479	Frigidaire
GLRT188WDB4	241588201	4.25	479	Frigidaire
GLRT188WDB6	241588201	4.25	479	Frigidaire
GLRT188WDK0	241588200	4.25	479	Frigidaire
GLRT188WDK2	241643400	4.25	479	Frigidaire
GLRT188WDK4	241588201	4.25	479	Frigidaire
GLRT188WDK6	241588201	4.25	479	Frigidaire
GLRT188WDL2	241643400	4.25	479	Frigidaire
GLRT188WDL3	241588200	4.25	479	Frigidaire
GLRT188WDL4	241588201	4.25	479	Frigidaire
GLRT188WDL5	241643400	4.25	479	Frigidaire
GLRT188WDL6	241588201	4.25	479	Frigidaire
GLRT188WDS0	241588200	4.25	479	Frigidaire
GLRT188WDS2	241643400	4.25	479	Frigidaire
GLRT188WDS4	241588201	4.25	479	Frigidaire
GLRT188WDS6	241588201	4.25	479	Frigidaire
GLRT188WDW0	241588200	4.25	479	Frigidaire
GLRT188WDW2	241643400	4.25	479	Frigidaire
GLRT188WDW4	241588201	4.25	479	Frigidaire
GLRT188WDW6	241588201	4.25	479	Frigidaire
GLRT188WDZ	241588201	4.25	479	Frigidaire
GLRT188WDZ0	241588200	4.25	479	Frigidaire
GLRT188WDZ2	241643400	4.25	479	Frigidaire
GLRT212IDB4	240379014	4.25	509	Frigidaire
GLRT212IDB5	240379014	4.25	509	Frigidaire
GLRT212IDB7	241643300	4.25	509	Frigidaire
GLRT212IDB9	240379014	4.25	509	Frigidaire
GLRT212IDQ4	240379014	4.25	509	Frigidaire
GLRT212IDQ5	240379014	4.25	509	Frigidaire
GLRT212IDQ7	241643300	4.25	509	Frigidaire
GLRT212IDQ9	240379014	4.25	509	Frigidaire
GLRT212IDW4	240379014	4.25	509	Frigidaire
GLRT212IDW5	240379014	4.25	509	Frigidaire
GLRT212IDW7	241643300	4.25	509	Frigidaire
GLRT212IDW9	240379014	4.25	509	Frigidaire
GLRT214TCBC	240379014	4.25	509	Frigidaire
GLRT214TCQC	240379014	4.25	509	Frigidaire
GLRT214TCWC	240379014	4.25	509	Frigidaire
GLRT217TDB9	241588200	4.25	509	Frigidaire
GLRT217TDBN	241588200	4.25	509	Frigidaire
GLRT217TDKA	241588200	4.25	509	Frigidaire

Model	Service Data Sheet	Charge (oz.)	Energy Efficiency Rating (KWH / Year)	Brand
GLRT217TDKN	241588200	4.25	509	Frigidaire
GLRT217TDQ9	241588200	4.25	509	Frigidaire
GLRT217TDQN	241588200	4.25	509	Frigidaire
GLRT217TDSA	241588200	4.25	509	Frigidaire
GLRT217TDSN	241588200	4.25	509	Frigidaire
GLRT217TDSP	241588200	4.25	509	Frigidaire
GLRT217TDW9	241588200	4.25	509	Frigidaire
GLRT217TDWN	241588200	4.25	509	Frigidaire
GLRT218WDB2	241588200	4.25	509	Frigidaire
GLRT218WDB3	241643400	4.25	509	Frigidaire
GLRT218WDB5	241588200	4.25	509	Frigidaire
GLRT218WDB7	241588200	4.25	509	Frigidaire
GLRT218WDK3	241643400	4.25	509	Frigidaire
GLRT218WDK5	241588200	4.25	509	Frigidaire
GLRT218WDK7	241588200	4.25	509	Frigidaire
GLRT218WDQ2	241588200	4.25	509	Frigidaire
GLRT218WDS3	241588200	4.25	509	Frigidaire
GLRT218WDS5	241588200	4.25	509	Frigidaire
GLRT218WDS7	241588200	4.25	509	Frigidaire
GLRT218WDS9	241588200	4.25	509	Frigidaire
GLRT218WDW2	241588200	4.25	509	Frigidaire
GLRT218WDW3	241588200	4.25	509	Frigidaire
GLRT218WDW5	241588200	4.25	509	Frigidaire
GLRT218WDW7	241588200	4.25	509	Frigidaire
GLRT218WDZ3	241588200	4.25	509	Frigidaire
GLRT218WDZ5	241588200	4.25	509	Frigidaire
GLRT218WDZ7	241588200	4.25	509	Frigidaire
GLRT83TEK0	240379015	4.25	479	Frigidaire
GLRT83TEK2	240379015	4.25	479	Frigidaire
GLRT83TEK4	240379015	4.25	479	Frigidaire
GLRT83TES0	240379015	4.25	479	Frigidaire
GLRT83TES2	240379015	4.25	479	Frigidaire
GLRT83TES4	240379015	4.25	479	Frigidaire
GLRT86TEB0	240379015	4.25	479	Frigidaire
GLRT86TEB2	240379015	4.25	479	Frigidaire
GLRT86TEB4	240379015	4.25	479	Frigidaire
GLRT86TEK0	240379015	4.25	479	Frigidaire
GLRT86TEK2	240379015	4.25	479	Frigidaire
GLRT86TEQ0	240379015	4.25	479	Frigidaire
GLRT86TEQ2	240379015	4.25	479	Frigidaire
GLRT86TEQ4	240379015	4.25	479	Frigidaire
GLRT86TES0	240379015	4.25	479	Frigidaire
GLRT86TES2	240379015	4.25	479	Frigidaire
GLRT86TEW0	240379015	4.25	479	Frigidaire
GLRT86TEW2	240379015	4.25	479	Frigidaire
GLRT86TEW4	240379015	4.25	479	Frigidaire
GS18HTZDB4	240379015	4.25	407	Frigidaire
GS18HTZDB5	241588200	4.25	407	Frigidaire
GS18HTZDPB4	240379015	4.25	407	Frigidaire
GS18HTZDPB5	240379014	4.25	407	Frigidaire
GS18HTZDQ0	240379015	4.25	407	Frigidaire
GS18HTZDSB2	240379015	4.25	407	Frigidaire
GS18HTZDSB4	240379015	4.25	407	Frigidaire
GS18HTZDSK2	240379015	4.25	407	Frigidaire

Model	Service Data Sheet	Charge (oz.)	Energy Efficiency Rating (KWH / Year)	Brand
GS18HTZDSK4	240379015	4.25	407	Frigidaire
GS18HTZDSW0	240379015	4.25	407	Frigidaire
GS18HTZDSW4	240379015	4.25	407	Frigidaire
GS21HTZDB3	240379014	4.25	432	Frigidaire
GS21HTZDB5	240379014	4.25	432	Frigidaire
GS21HTZDK5	240379014	4.25	432	Frigidaire
GS21HTZDPB5	240379014	4.25	432	Frigidaire
GS21HTZDPW5	240379014	4.25	432	Frigidaire
GS21HTZDQ3	240379014	4.25	432	Frigidaire
GS21HTZDW3	240379014	4.25	432	Frigidaire
GS21HTZDW5	240379014	4.25	432	Frigidaire
PHSC239DSB5	241532603	6	584	Frigidaire
PHSC239DSB7	241532603	6	584	Frigidaire
PHSC39EESS1	241639000	6	584	Frigidaire
PHSC39EESS3	241639000	6	584	Frigidaire
PLHS237ZDBA	240389621	5	583	Frigidaire
PLHS239ZDBA	240389621	5	583	Frigidaire
PLHS267ZDB6	240389621	5.25	618	Frigidaire
PLHS267ZDB7	240389621	5.25	618	Frigidaire
PLHS269ZDB7	240389621	5.25	618	Frigidaire
PLHS269ZDB9	240389621	5.25	618	Frigidaire
PLHS37EESB0	240389620	5	583	Frigidaire
PLHS37EESB3	240389623	5	583	Frigidaire
PLHS39EESS1	241636600	5	583	Frigidaire
PLHS39EESS3	241636601	5	583	Frigidaire
PLHS39EESS5	241636601	5	583	Frigidaire
PLHS67EESB0	240389620	5.25	618	Frigidaire
PLHS67EESB5	240389623	5.25	618	Frigidaire
PLHS68EESB1	241636600	5.25	618	Frigidaire
PLHS69EESS1	241636600	5.25	618	Frigidaire
PLHS69EESS5	241636600	5.25	618	Frigidaire
PLHS69EESS7	241636600	5.25	618	Frigidaire
PLHT189CSB4	240379015	4.25	407	Frigidaire
PLHT189CSB6	240379015	4.25	407	Frigidaire
PLHT189CSB8	240379015	4.25	407	Frigidaire
PLHT189CSBA	240379015	4.25	407	Frigidaire
PLHT189CSBB	240379015	4.25	407	Frigidaire
PLHT189CSK4	240379015	4.25	407	Frigidaire
PLHT189CSK6	240379015	4.25	407	Frigidaire
PLHT189CSK8	240379015	4.25	407	Frigidaire
PLHT189CSKA	240379015	4.25	407	Frigidaire
PLHT189CSKB	240379015	4.25	407	Frigidaire
PLHT189SSB2	240379015	4.25	407	Frigidaire
PLHT189SSB4	240379015	4.25	407	Frigidaire
PLHT189SSK2	240379015	4.25	407	Frigidaire
PLHT189SSK4	240379015	4.25	407	Frigidaire
PLHT19WEB5	241588200	4.25	432	Frigidaire
PLHT19WEB7	241588200	4.25	432	Frigidaire
PLHT219SCB1	240379014	4.25	432	Frigidaire
PLHT219SCB3	241643300	4.25	432	Frigidaire
PLHT219SCB5	240379014	4.25	432	Frigidaire
PLHT219SCB7	240379014	4.25	432	Frigidaire
PLHT219SCK3	241643300	4.25	432	Frigidaire
PLHT219SCK5	240379014	4.25	432	Frigidaire

Model	Service Data Sheet	Charge (oz.)	Energy Efficiency Rating (KWH / Year)	Brand
PLHT219TCBN	240379014	4.25	432	Frigidaire
PLHT219TCBP	241643300	4.25	432	Frigidaire
PLHT219TCBR	241643300	4.25	432	Frigidaire
PLHT219TCBS	240379014	4.25	432	Frigidaire
PLHT219TCKN	240379014	4.25	432	Frigidaire
PLHT219TCKP	241643300	4.25	432	Frigidaire
PLHT219TCKR	241643300	4.25	432	Frigidaire
PLHT219TCKS	240379014	4.25	432	Frigidaire
GRT17G4BW3	240379011	4.5	460	Gibson
GRT17G4BW4	240379015	4.5	460	Gibson
GRT18S6AWG	240379015	4.25	479	Gibson
GRT18S6AWH	240379015	4.25	479	Gibson
GRT18S6AWJ	240379015	4.25	479	Gibson
WRS23MF5ASF	240389616	5	686	White-Westinghouse
WRS23MW3AWD	240389616	5	686	White-Westinghouse
WRS23W0AWF	240389616	5	686	White-Westinghouse
WRS26MF5ASF	240389616	5.25	727	White-Westinghouse
WRS3R3EW0	240389616	5	686	White-Westinghouse
WRS6R3EW0	240389616	5.25	727	White-Westinghouse
WRS6R3EW1	240389616	5.25	727	White-Westinghouse
WRS6W1FW0	240389616	5.25	727	White-Westinghouse
WRT15MG4BQ3	240379015	4.25	433	White-Westinghouse
WRT15MG4BQ4	240379015	4.25	433	White-Westinghouse
WRT15MG4BQ5	240379015	4.25	433	White-Westinghouse
WRT15MG4BW3	240379015	4.25	433	White-Westinghouse
WRT15MG4BW4	240379015	4.25	433	White-Westinghouse
WRT15MG5CS3	240379015	4.25	433	White-Westinghouse
WRT15MG5CS4	240379015	4.25	433	White-Westinghouse
WRT17MG4BW3	240379015	4.25	433	White-Westinghouse
WRT18MP5AQH	240379015	4.25	479	White-Westinghouse
WRT18MP5AQJ	240379015	4.25	479	White-Westinghouse
WRT18MP5AWH	240379015	4.25	479	White-Westinghouse
WRT18MP5AWJ	240379015	4.25	479	White-Westinghouse
WRT18MP6CS8	240379015	4.25	479	White-Westinghouse
WRT18MP6CSA	240379015	4.25	479	White-Westinghouse
WRT1G3EW0	240379014	4.25	509	White-Westinghouse
WRT1G3EW1	240379014	4.25	509	White-Westinghouse
WRT21MG3AQB	240379014	4.25	509	White-Westinghouse
WRT21MG3AWB	240379014	4.25	509	White-Westinghouse
WRT21MG3AWN	240379014	4.25	509	White-Westinghouse
WRT21MP5AWA	240379014	4.25	509	White-Westinghouse
WRT21MR7ASE	240379014	4.25	509	White-Westinghouse
WRT21MR7ASN	240379014	4.25	509	White-Westinghouse
WRT21S4AW9	240379014	4.25	509	White-Westinghouse
WRT5B1EW0	240379015	4.5	443	White-Westinghouse
WRT5B1EW1	240379015	4.5	443	White-Westinghouse
WRT5B1EW2	240379015	4.5	443	White-Westinghouse
WRT7A2EW0	240379015	4.5	460	White-Westinghouse
WRT7A2EW1	240379015	4.5	460	White-Westinghouse
WRT7A2EW2	240379015	4.5	460	White-Westinghouse
WRT8A1EW0	240379015	4.5	479	White-Westinghouse
WRT8A1EW2	240379015	4.5	479	White-Westinghouse
WRT8A1EW4	240379015	4.5	479	White-Westinghouse
WRT8G3EQ0	240379015	4.5	479	White-Westinghouse

Model	Service Data Sheet	Charge (oz.)	Energy Efficiency Rating (KWH / Year)	Brand
WRT8G3EQ2	240379015	4.5	479	White-Westinghouse
WRT8G3EW0	240379015	4.5	479	White-Westinghouse
WRT8G3EW2	240379015	4.5	479	White-Westinghouse
WRT8G3EW4	240379015	4.5	479	White-Westinghouse

TROUBLESHOOTING GUIDE

PROBLEM	CAUSE	SOLUTION
Compressor will not run.	No voltage at wall receptacle.	Check circuit breaker, fuse or GFCI (Ground Fault Circuit Interruptor - It is not recommended to connect your refrigerator to a GFCI.)
	Service cord defective or unplugged at wall receptacle.	Check service cord.
	Low voltage causing compressor to cycle on overload.	Voltage fluctuation should not exceed \pm 10% of 115 vac (104-127)
	Control thermostat knob in OFF position or electronic control is in the off position.	Turn control thermostat knob to ON position. In the case of the electronic control press and hold the ON/OFF switch on the control until the OFF in the display is replaced with the set point.
	Inoperative control thermostat on electrical mechanical models. Bad Electronic control on counter depth or standard depth with electronic control.	Replace control thermostat on electrical mechanical models. On electronic models follow the test procedure for the type control the product is equipped with.
	Compressor stuck.	Replace compressor.
	Compressor windings open.	Replace compressor.
	Defrost timer stuck in defrost mode.	Replace defrost timer. (if equipped)
	ADC (Adaptive Defrost Control) not turning on compressor after defrost.	Replace ADC.
	Compressor overload stuck open on standard compressor models. On variable speed (VCC) models the inverter may be bad.	Replace compressor overload. (if equipped – compressor starter relay & overload may be plugged into each other) If the product is equipped with a VCC compressor and you have 2 to 5 VDC at the connection from the control board, 115 VAC at the connection for the service cord and the compressor windings check good, replace the inverter.
	Relay lead loose.	Repair or replace lead.
	Relay loose or inoperative.	Repair or replace relay. (if equipped)
	Service cord pulled out of harness.	Repair connection.
	Faulty cabinet wiring.	Repair wiring.
Compressor runs but does not cool.	System out of refrigerant.	Check for leaks. *
	Compressor not pumping.	Replace compressor. *
	Restricted filter drier.	Replace filter drier. *
	Restricted capillary tube.	Replace heat exchanger and evaporator assembly.
	Moisture in system.	See NOTE. *

*** NOTE:**

- Repair or replace component that is leaking.
- Replace the compressor if the system is contaminated.
- Blow out remaining part of system with dry Nitrogen.
- Pump down and recharge per listing on product serial label.
- Always replace filter drier when repairing sealed system.

PROBLEM	CAUSE	SOLUTION
Compressor short cycles.	Erratic control thermostat.	Replace control thermostat.
	Faulty relay.	Replace relay or starter.
	Restricted air flow over condenser.	Ensure air flow is unobstructed over condenser.
	Low voltage ... fluctuation exceeds $\pm 10\%$ of 115 vac (104-127).	Call qualified electrician.
	Compressor draws excessive watts.	Replace compressor.
	Inoperative condenser fan motor.	Replace condenser fan motor.
Compressor runs too much.	Control thermostat is erratic or not properly set.	Replace control thermostat or reset to normal position.
	Refrigerator exposed to high heat. (110° or higher)	Move refrigerator to cooler location.
	High room temperature. (110° F or higher)	Advise customer not to install refrigerator where temperature will rise above 110°F because compressor will not maintain proper temperatures.
	Low pumping capacity compressor.	Replace compressor.
	Door gaskets not sealing.	Adjust doors or replace door gaskets.
	System undercharged.	Check for leaks. *
	System overcharged.	Charge per listing on product serial plate. *
	Interior light stays on.	Check door switch and door adjustment.
	Contaminants in system.	Flush out system. Replace filter drier, evacuate, and recharge. *
	Capillary tube kinked or partially restricted.	Replace heat exchanger and evaporator assembly. *
	Filter drier partially restricted.	Replace filter drier. *
	Refrigerator and/or freezer compartment overloaded ... poor air circulation	Advise customer.
	Restricted air flow over condenser.	Ensure air flow is unobstructed over condenser.
	Condenser fan motor is inoperative. (Forced air condenser models only)	Replace condenser fan motor.
Noisy.	Tubing vibrates.	Adjust tubing.
	Internal compressor noise.	Replace compressor.
	Loose parts.	Check shelving.
	Compressor operating at high head pressure due to restricted air flow over condenser.	Ensure air flow is unobstructed over condenser.

* See NOTE at bottom of page 18.

PROBLEM	CAUSE	SOLUTION
<p>Freezer compartment too warm.</p> <div data-bbox="120 302 522 667"> <p>Fig. A</p> <p>The front edge of each fan blade must extend 1/8" beyond the face of the coil cover</p> </div>	<p>Inoperative evaporator fan motor.</p> <p>Improperly positioned fan blade.</p> <p>Evaporated frosted up.</p> <p>Inoperative condenser fan motor. (Forced air condenser models only)</p> <p>Restricted air flow over condenser – On static condensers, be sure you have 1" between condenser and wall, and 3" over top, or 1" side of condenser is clear.</p> <p>Freezer compartment overloaded – poor air circulation.</p> <p>Low room temperature.(55°)</p> <p>Freezer or refrigerator compartment doors left open.</p> <p>Control thermostat out of calibration. Thermistor checks open or shorted.</p> <p>Door gaskets not sealing.</p> <p>Control thermostat capillary tube improperly positioned. Thermistor is improperly positioned on electronic control models.</p> <p>Shortage of refrigerant.</p> <p>Restricted filter drier or capillary tube.</p> <p>Evaporator fan motor covered in ice.</p>	<p>Check wiring and evaporator fan motor. Check ADC on Side-by-Sides with electrical mechanical control. Check the electronic control on SxS models equipped with the electronic control system.</p> <p>Position fan blade properly. See Figure A.</p> <p>Check defrost system timers ADC and electronic control depending on control system product is equipped with. Check the door adjustments, and door gaskets.</p> <p>Replace condenser fan motor.</p> <p>Clean condenser. (Dynamic models only.)</p> <p>Advise customer.</p> <p>Advise customer not to install refrigerator where temperature will drop below 60°F. Compressor will not maintain proper temperatures.</p> <p>Advise customer.</p> <p>Replace control thermostat. Replace thermistor.</p> <p>Adjust doors or replace door gaskets.</p> <p>Reposition temperature sensing element.</p> <p>Check for leaks. *</p> <p>Check for leaks and burnt compressor windings. *</p> <p>Check seal around ice maker fill spout. Check seal between evaporator cover and liner. (Side-by-sides only)</p>
<p>Freezer compartment too cold.</p>	<p>Inoperative cold control. (Top mount-No Frost or Side-by-Side freezer cold control) Bad electronic control on SxS equipped with electronic control system.</p> <p>Freezer compartment inlet air duct is loose or restricted. Door is loose.</p> <p>Food compartment air return duct blocked (Top Mount only)</p> <p>Diffuser (foam block) in top of food compartment is broken. (Foam block located in control housing.)</p>	<p>Replace cold control or electronic control.</p> <p>Re-install air duct or remove obstruction from inlet air duct. Adjust door.</p> <p>If foam block is frozen, replace block. If duct is blocked, remove obstruction.</p> <p>Replace diffuser. (Top Mount only) Freezer compartment cold control installed incorrectly. (Side-by-Sides only)</p>

* See NOTE at bottom of page 18.

PROBLEM	CAUSE	SOLUTION
Refrigerator compartment too warm.	Inoperative evaporator fan motor.	Check wiring and evaporator fan motor. (Check ADC on Side-by-Sides.)
	Improperly positioned fan blade.	Position fan blade properly. See page 20, Figure A.
	Evaporated frosted up.	Check defrost system timers ADC and electronic control depending on control system product is equipped with. Check the door adjustments and door gaskets.
	Refrigerator compartment overloaded – poor air circulation.	Advise customer.
	Low room temperature. (55°)	Advise customer not to install refrigerator where temperature will drop below 60°F. Compressor will not maintain proper temperatures.
	Freezer or refrigerator compartment doors left open.	Advise customer.
	Damper control out of calibration or not opening.	Replace damper control.
	Shortage of refrigerant.	Check for leaks. *
	Restricted filter drier or capillary tube.	Check for leaks and burnt compressor windings. *
	Refrigerator compartment inlet air duct loose or restricted. Door is loose.	Re-install air duct or remove obstruction from air duct. Adjust door.
	Freezer compartment return air duct restricted.	Remove obstruction from return air duct.
	Control thermostat knob or electronic control is set at too warm a position.	Set control to a colder position.
	Inoperative or erratic refrigerator/freezer compartment door switch.	Replace door switch.
	Freezer compartment inlet air duct is loose or restricted. Door is loose.	Re-install air duct or remove obstruction from inlet air duct. Adjust door.
	Food compartment air return duct blocked (Top Mount only)	If foam block is frozen, replace block. If duct is blocked, remove obstruction.
Refrigerator compartment too cold.	Inoperative cold control. (Top mount-No Frost or Side-by-Side freezer cold control) Bad electronic control on SxS equipped with electronic control system.	Replace cold control or electronic control.
	Refrigerator compartment inlet air duct loose or restricted. Door is loose.	Re-install air duct or remove obstruction from air duct. Adjust door.
	Diffuser (foam block) in top of food compartment is broken. (Foam blocked located in control housing.)	Replace diffuser. (Top Mounts only)

* See NOTE at bottom of page 18.

PROBLEM	CAUSE	SOLUTION
Refrigerator compartment too cold. (Continued)	Inoperative cold control or electronic control.	Replace cold control or electronic control.
	Refrigerator compartment inlet air duct loose or restricted. Door is loose.	Re-install air duct or remove obstruction from air duct. Adjust door.
	Diffuser (foam block) in top of food compartment is broken. (Foam blocked located in control housing)	Replace diffuser. (Top Mounts only)
	Door in damper control not closing or not closing all the way.	Replace damper control.
		Check freezer control bulb for correct positioning to ensure it is installed correctly.
Cold air blowing into food compartment with damper door closed all the way.	Check foam seal between damper housing and cabinet liner. Check to see that the control box is mounted flush against the cabinet liner.	
Evaporator blocked with ice. (See Adaptive defrost Control or electronic control system)	Inoperative defrost timer, ADC, Electronic Control.	Check wiring. Repair or replace defrost control.
	Defrost thermostat terminates too early. Thermostat is open.	Check for correct positioning of defrost thermostat. Repair or replace.
	Refrigerator/Freezer compartment doors left open.	Advise customer.
	Open defrost heater.	Replace heater.
	Air leak around ice maker fill tube, or water line opening, or door seals.	Seal fill tube and/or water lines with permagum. If door seals are bad, replace. If seals are not tight in channel, seal channel with silicone sealer.
Frozen drain.	Ice maker water line and wiring harness openings not sealed.	Seal water line and wiring harness openings.
	Drain trough not properly formed.	Ensure drain trough is at 90° angle to back of freezer and that lip is up on front and ends.
	Divider (foam block) frozen.	Replace divider. Check drain trough.
Adaptive Defrost Control (ADC) or Electronic Control not responding correctly.	Faulty ADC board or electronic control	Replace ADC board or Electronic Control..
	Bad wire between ADC/Electronic Control, defrost heater, and limiter.	Check wiring and wiring connectors.

PERFORMANCE DATA NO LOAD AND NO DOOR OPENINGS AT MID-POINT CONTROL SETTING				
Type A With Run Capacitor	65°F (18°C) Ambient	90°F (32°C) Ambient		
Operating Time	25 to 35%	45 to 55%		
Freezer Temperature	2° to 8°F -17° to -13°C	0° to 5°F -18° to -15°C		
Refrigerature Temperature	35° to 40°F 2° to 4°C	35° to 40°F 2° to 4°C		
Low Side Pressure (cut-in)	8 to 16 psig 55 to 110 kPa	8 to 16 psig 55 to 110 kPa		
Low Side Pressure (cut-out)	1 to 4 psig 7 to 28 kPa	1 to 4 psig 7 to 28 kPa		
High Side Pressure (Last 1/3 of cycle)	110 to 120 psig 758 to 827 kPa	150 to 175 psig 1034 to 1207 kPa		
Wattage (Last 1/3 of cycle)	140 to 185	140 to 185		
Amps (Running)	1.1 to 1.6	1.1 to 1.6		
Base Voltage	115 VAC	115 VAC		
DEFROST SPECIFICATIONS				
Cabinet Size	Thermostat		Heater	
	Cut-in	Cut-out	Watts	Ohms
18' & 21'	25°F -4°C	47°F 8°C	375	35
15' & 17'	25°F -4°C	47°F 8°C	325	41
Defrost 30 Minutes Every 10 Hours of Compressor Run Time				
CONDENSER FAN MOTOR				
Watts	RPM	Amps		
2.3	1100 CW Opposite Shaft	.15 Running		
ICE MAKER SPECIFICATIONS				
Electrical	115 Volts	60 Hertz		
Thermostat	Opens at 48°F (9°C)	Closes at 15°F (-9°C)		
Heater Wattage	165			
ICE MAKER CONNECTOR PLUG CONNECTIONS				
Wire Number	Wire Color	Connects to:		
1	Green/Yellow	Ground		
2	Yellow	Water Valve		
3	Black	Line		
4	Lt. Blue	Neutral		

SERVICE DATA SHEET

STANDARD - AUTOMATIC
DEFROST TOP FREEZER
MODELS (R134a)

P/N: 240379005
(12594301)

IMPORTANT SAFETY NOTICE

The information provided herein is designed to assist qualified repair personnel only. Untrained persons should not attempt to make repairs due to the possibility of electrical shock. Disconnect power cord before servicing.

IMPORTANT

If any green grounding wires are moved during servicing, they must be returned to their original position and properly secured.

CAUTION: All electrical parts and wiring must be shielded from torch flame. Do not allow torch to contact insulation; it will char at 200°F and flash ignite (burn) at 500°F. Excessive heat will distort the plastic liner.

ICE MAKER INFORMATION

Test Cycling

Remove cover by inserting screwdriver in notch at bottom and prying cover from housing. Use screwdriver to rotate motor gear counterclockwise until *Holding Switch* circuit is completed. All components of ice maker should function to complete the cycle.

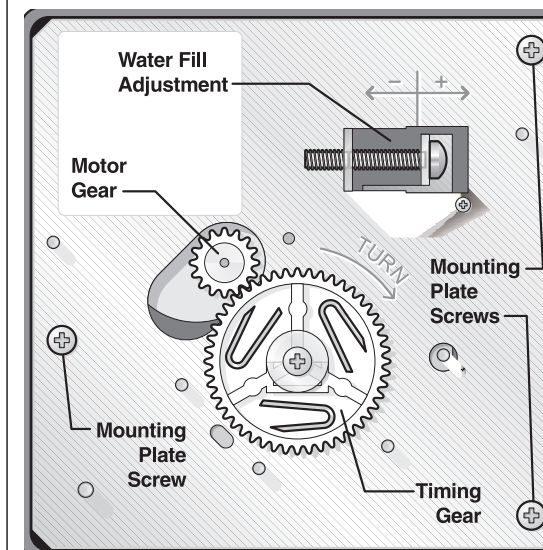

Water Fill Volume

The water fill adjustment screw will change the fill time. One full turn is equal to 20cc (.68 oz.). The correct fill is 102 to 130cc (3.4 to 4.3 oz.). When a water valve is replaced, the fill volume must be checked.

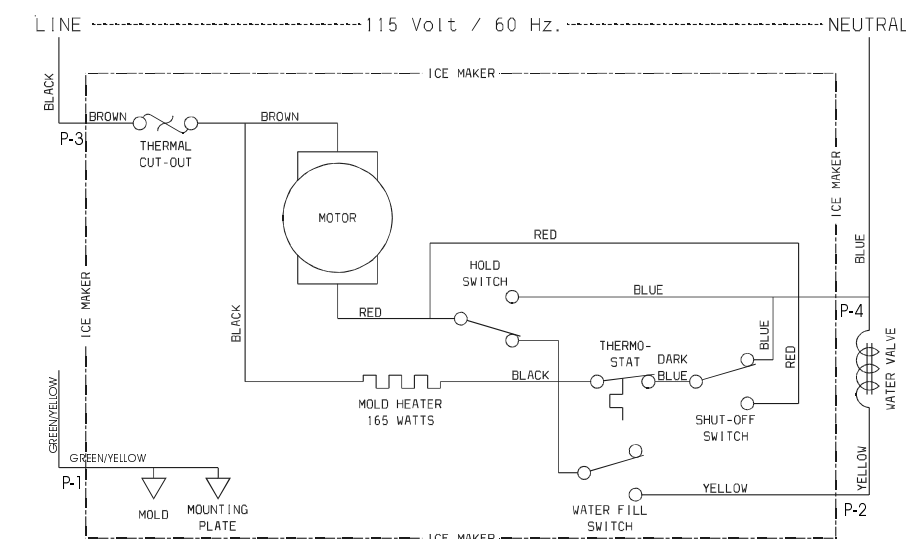
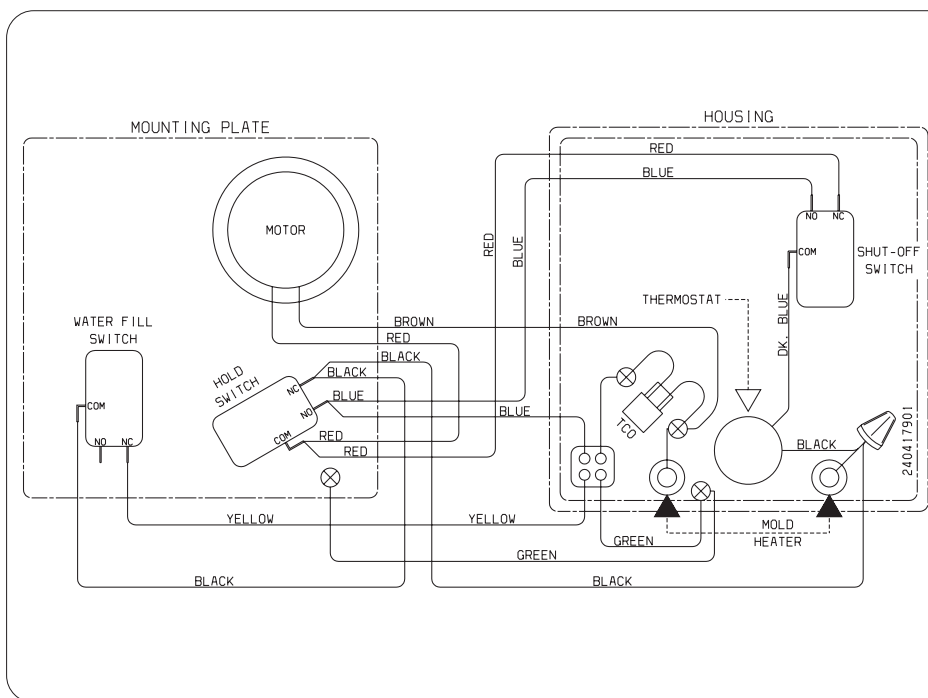

Pictorial Schematic

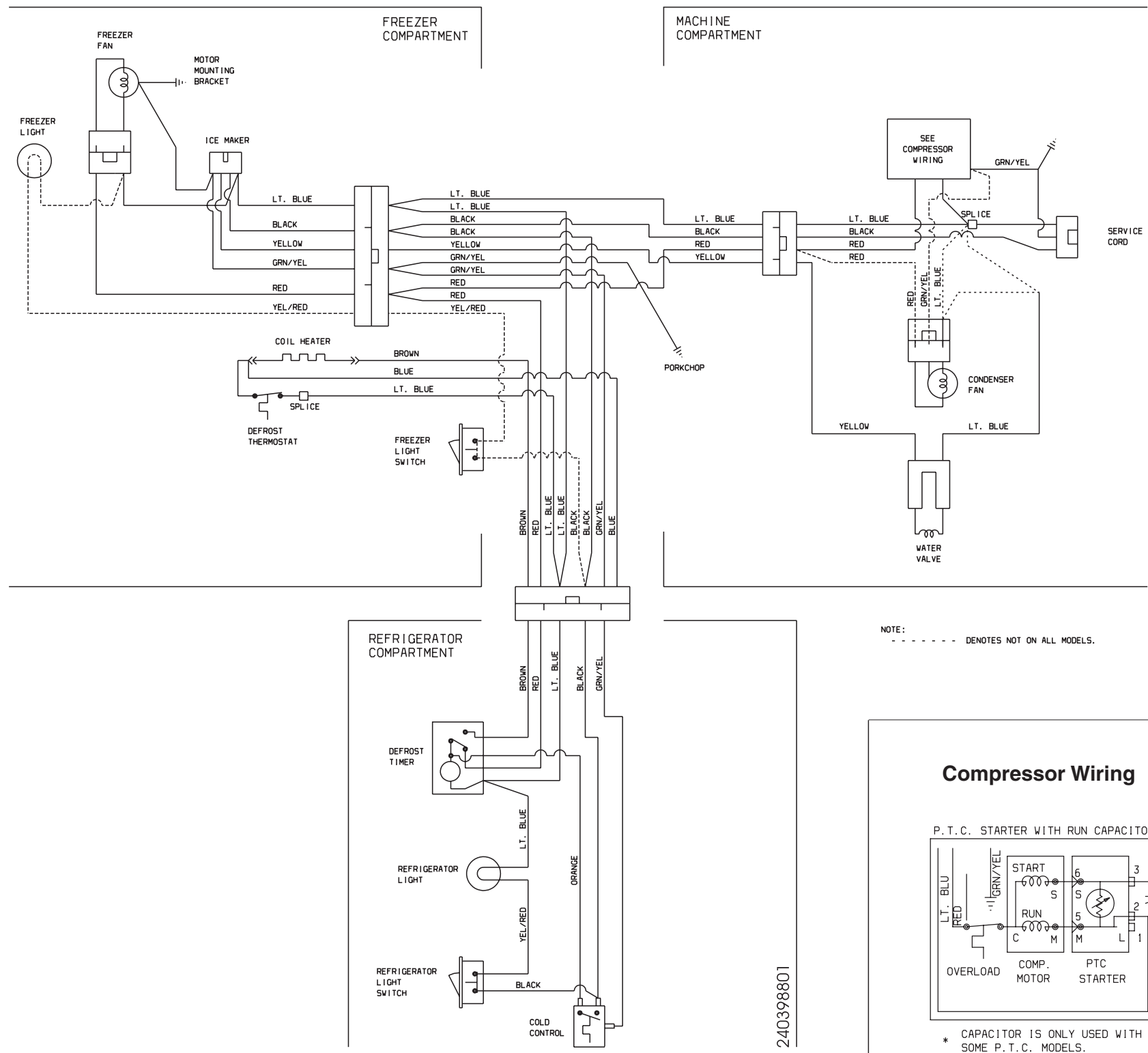

NOTE: - - - - DENOTES NOT ON ALL MODELS.

Compressor Wiring

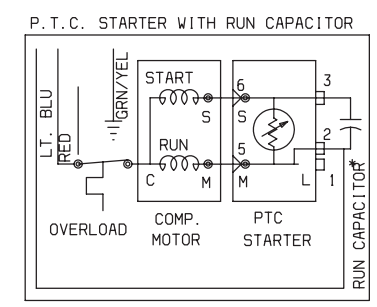

* CAPACITOR IS ONLY USED WITH SOME P. T. C. MODELS.

Ladder Schematic

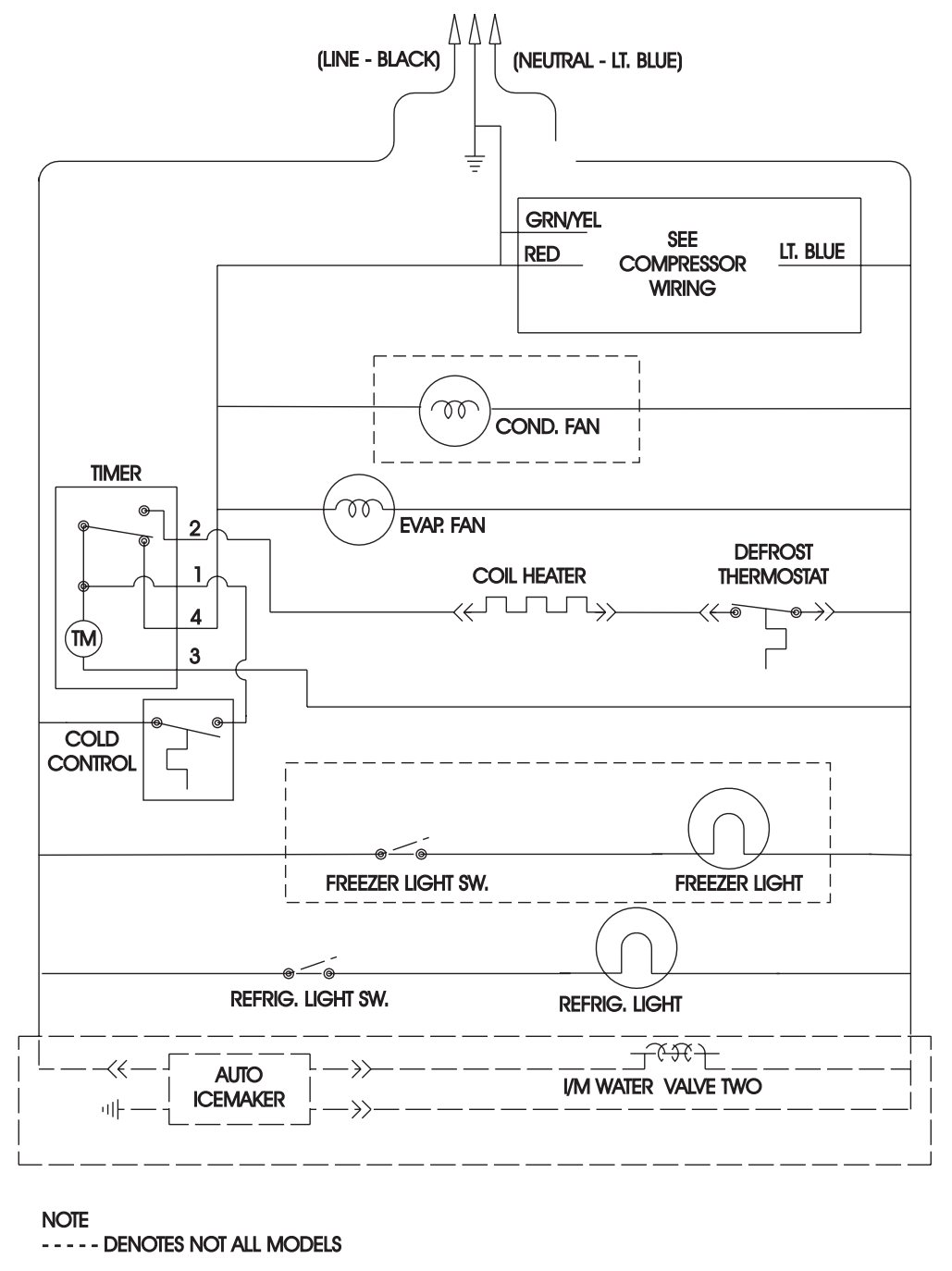

PERFORMANCE DATA NO LOAD AND NO DOOR OPENINGS AT MID-POINT CONTROL SETTING				
Capacitor Run or Induction Run	65°F (18°C) Ambient	90°F (32°C) Ambient		
Operating Time	25 to 35%	45 to 55%		
Freezer Temperature	2° to 8°F -17° to -13°C	0° to 5°F -18° to -15°C		
Refrigerature Temperature	35° to 40°F 2° to 4°C	35° to 40°F 2° to 4°C		
Low Side Pressure (cut-in)	8 to 16 psig 55 to 110 kPa	8 to 16 psig 55 to 110 kPa		
Low Side Pressure (cut-out)	1 to 4 psig 7 to 28 kPa	1 to 4 psig 7 to 28 kPa		
High Side Pressure (Last 1/3 of cycle)	110 to 120 psig 758 to 827 kPa	150 to 175 psig 1034 to 1207 kPa		
Wattage (Last 1/3 of cycle)	140 to 185	140 to 185		
Amps (Running)	1.1 to 1.6	1.1 to 1.6		
Base Voltage	115 VAC (127 VAC Max)	115 VAC (127 VAC Max)		
DEFROST SPECIFICATIONS				
Cabinet Size	Thermostat		Heater	
	Cut-in	Cut-out	Watts	Ohms
18' & 21'	25°F -4°C	47°F 8°C	375	35
14', 15' & 17'	25°F -4°C	47°F 8°C	325	41
Mechanical Timer - Defrost 30 Minutes Every 10 Hours of Compressor Run Time Electronic Timer (ADC) Defrost Up To 24 Minutes Every 6 - 72 Hours of Compressor Run Time				
CONDENSER FAN MOTOR				
Watts	RPM	Amps		
2.3	1100 CW Opposite Shaft	.15 Running		
ICE MAKER SPECIFICATIONS				
Electrical	115 VAC (127 VAC Max)	60 Hertz		
Thermostat	Opens at 48°F (9°C)	Closes at 15°F (-9°C)		
Heater Wattage	165			
ICE MAKER CONNECTOR PLUG CONNECTIONS				
Wire Number	Wire Color	Connects to:		
1	Green/Yellow	Ground		
2	Yellow	Water Valve		
3	Black	Line		
4	Lt. Blue	Neutral		

SERVICE DATA SHEET

STANDARD - AUTOMATIC
DEFROST TOP FREEZER
MODELS (R134a) | P/N: 240379011

IMPORTANT SAFETY NOTICE

The information provided herein is designed to assist qualified repair personnel only. Untrained persons should not attempt to make repairs due to the possibility of electrical shock. Disconnect power cord before servicing.

IMPORTANT

If any green grounding wires are moved during servicing, they must be returned to their original position and properly secured.

CAUTION: All electrical parts and wiring must be shielded from torch flame. Do not allow torch to contact insulation; it will char at 200°F and flash ignite (burn) at 500°F. Excessive heat will distort the plastic liner.

NOTE: Some products come equipped with an Electronic Defrost Control. To initiate defrost, depress the fresh food light switch 5 times in 6 seconds (light bulb must be working). To terminate defrost, depress the fresh food light switch 5 times in 6 seconds.

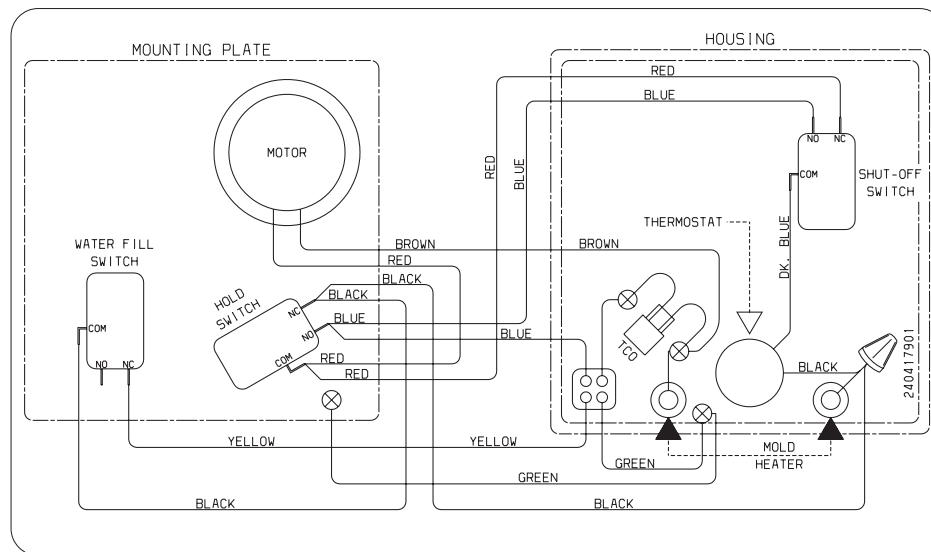

ICE MAKER INFORMATION

Test Cycling

Remove cover by inserting screwdriver in notch at bottom and prying cover from housing. Use screwdriver to rotate motor gear counterclockwise until *Holding Switch* circuit is completed. All components of ice maker should function to complete the cycle.

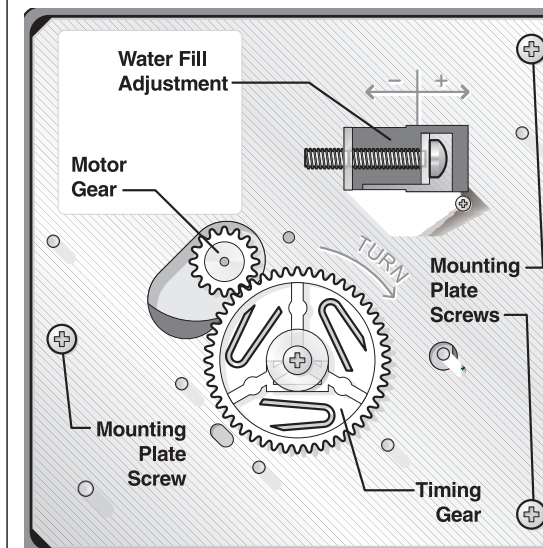

Water Fill Volume

The water fill adjustment screw will change the fill time. One full turn is equal to 20cc (.68 oz.). The correct fill is 95 to 105cc (3.2 to 3.6 oz.). When a water valve is replaced, the fill volume must be checked.

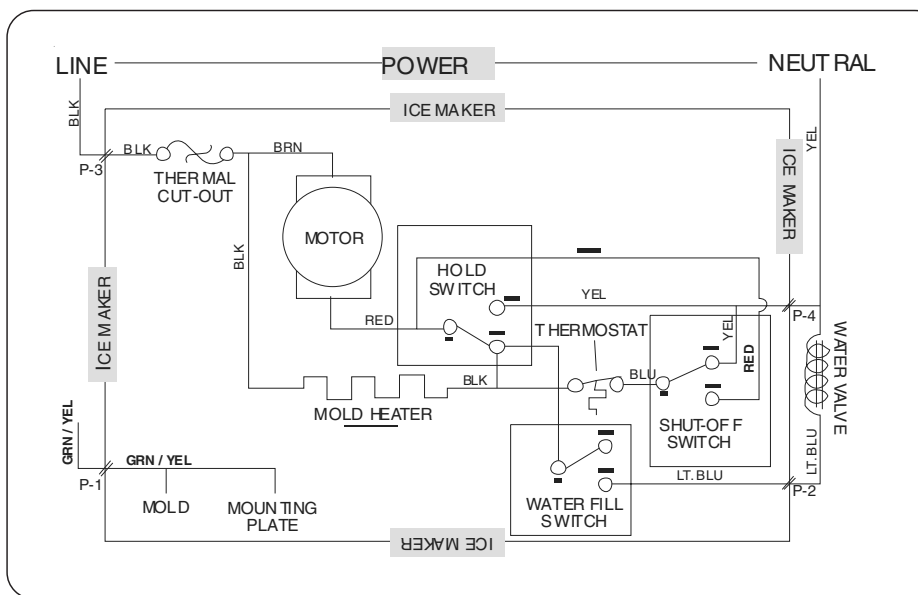

Pictorial Schematic

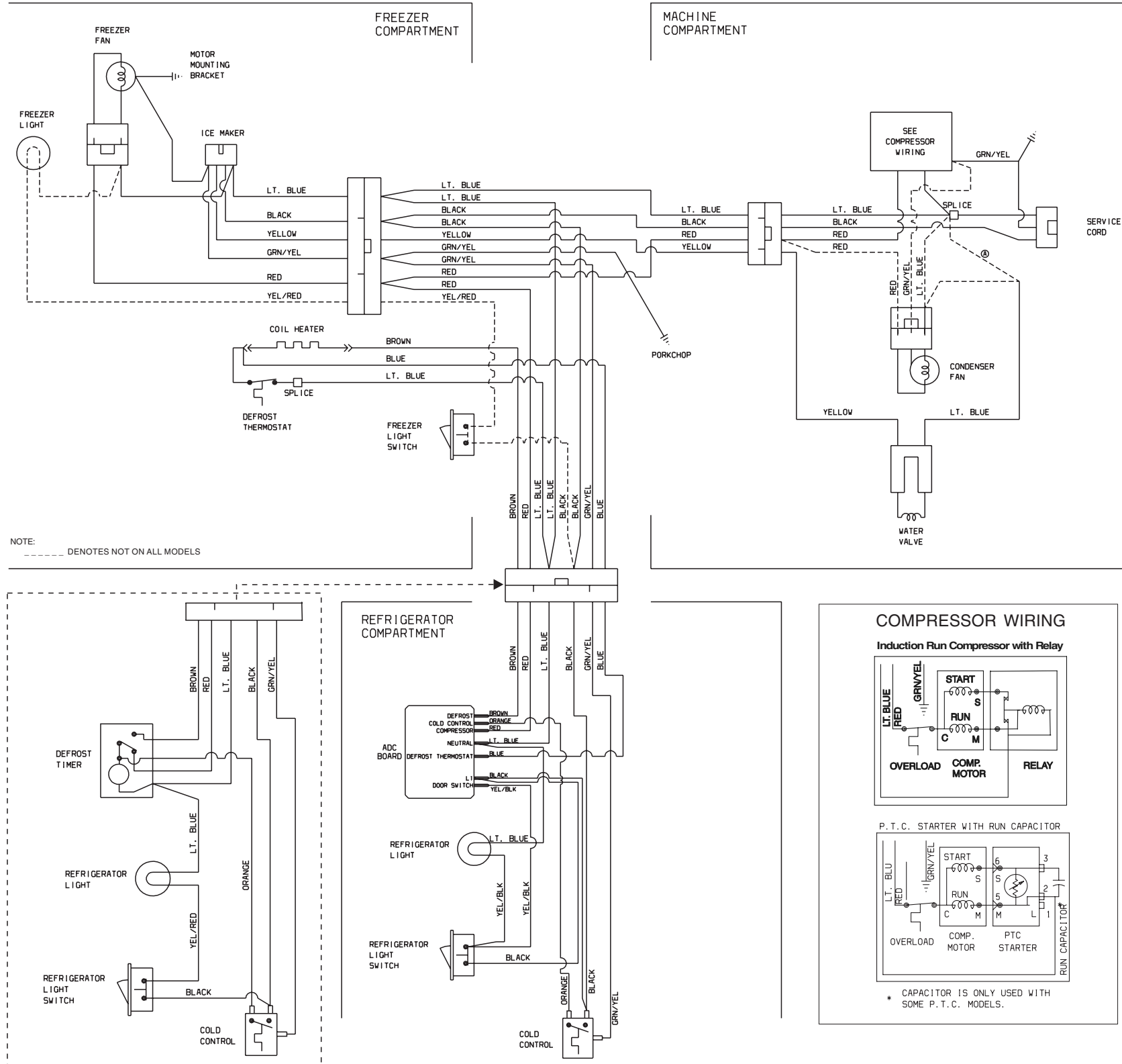

Ladder Schematic

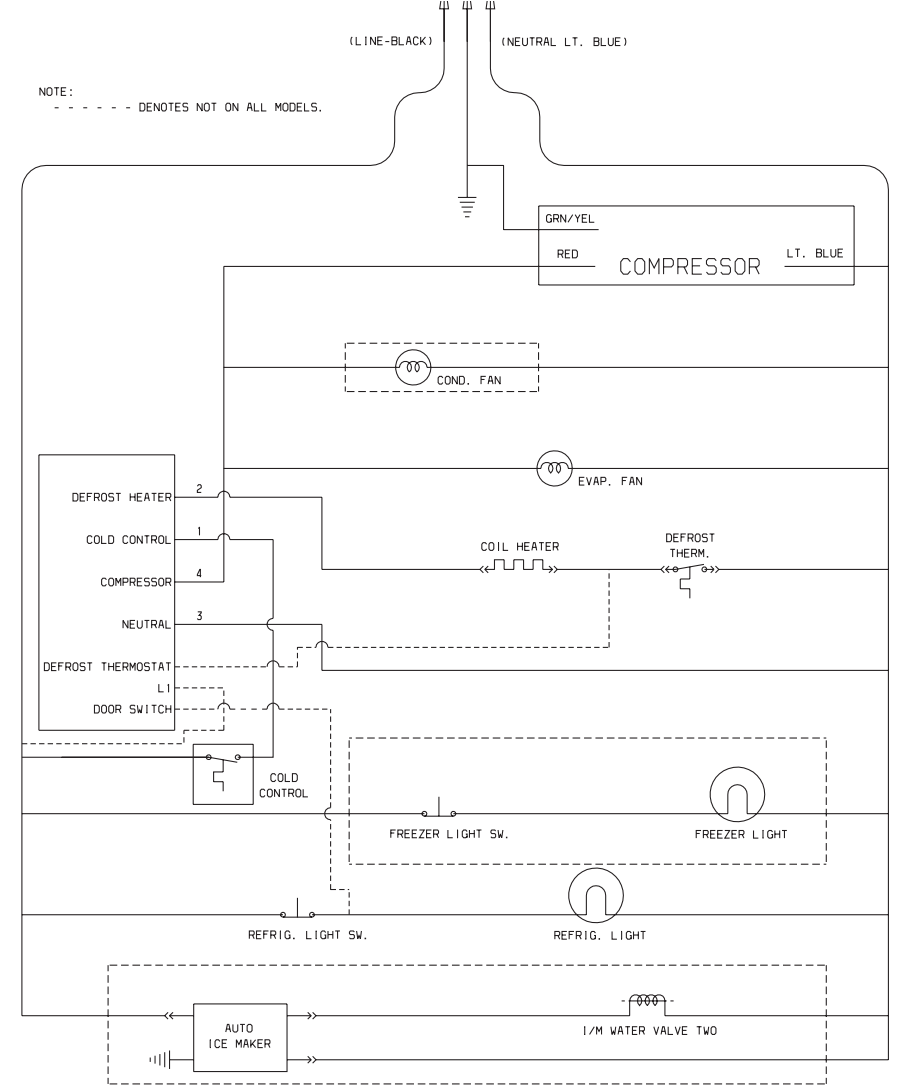

SERVICE PARTS	15 & 17 CUBIC FOOT			18 CUBIC FOOT			21 CUBIC FOOT	
	STATIC	DYNAMIC	E-STAR	STATIC	DYNAMIC	E-STAR	DYNAMIC	E-STAR
Compressor / Kit *	5303918264	5303918264	5303918295	240435705	240435705	5303918295	5303918264	5303918295
Starter/PTC *	218721120	218721120	218721120	218721120	218721120	218721120	218721120	218721120
Run Capacitor *	218909913	218909913	218909912	218909913	218909913	218909912	218909913	218909912
Relay	N/A	N/A	N/A	5304433579	5304433579	N/A	N/A	N/A
Overload	N/A	N/A	N/A	5304433578	5304433578	N/A	N/A	N/A
Temperature Control	5304421256	5304421256	5304421256	5304421256	5304421256	5304421256	5304421256	5304421256
Timer (if applicable)	215846606	215846606	215846606	215846606	215846606	215846606	215846606	215846606
ADC (if applicable)	N/A	N/A	N/A	N/A	N/A	N/A	N/A	N/A
Defrost Heater Kit	5303918203	5303918203	5303918203	5303918208	5303918208	5303918208	5303918247	5303918247
Defrost Thermostat Kit	5303918202	5303918202	5303918202	5303918202	5303918202	5303918202	5303918202	5303918202
Evaporator Fan Motor	240369701	240369701	240369701	240369701	240369701	240369701	240369701	240369701
Condenser Fan Motor	N/A	240523601	240523601	N/A	240523601	240523601	240334001	240334001

PERFORMANCE DATA NO LOAD AND NO DOOR OPENINGS AT MID-POINT CONTROL SETTING		
Capacitor Run or Induction Run	65°F (18°C) Ambient	90°F (32°C) Ambient
Operating Time	25 to 35%	45 to 55%
Freezer Temperature	2° to 8°F -17° to -13°C	0° to 5°F -18° to -15°C
Refrigerature Temperature	35° to 40°F 2° to 4°C	35° to 40°F 2° to 4°C
Low Side Pressure (cut-in)	8 to 16 psig 55 to 110 kPa	8 to 16 psig 55 to 110 kPa
Low Side Pressure (cut-out)	1 to 4 psig 7 to 28 kPa	1 to 4 psig 7 to 28 kPa
High Side Pressure (Last 1/3 of cycle)	110 to 120 psig 758 to 827 kPa	150 to 175 psig 1034 to 1207 kPa
Wattage (Last 1/3 of cycle)	140 to 185	140 to 185
Amps (Running)	1.1 to 1.6	1.1 to 1.6
Base Voltage	115 VAC (127 VAC Max)	115 VAC (127 VAC Max)

DEFROST SPECIFICATIONS				
Cabinet Size	Thermostat		Heater	
	Cut-in	Cut-out	Watts	Ohms
18' & 21'	25°F -4°C	47°F 8°C	375	35
14', 15' & 17'	25°F -4°C	47°F 8°C	325	41

Mechanical Timer - Defrost 30 Minutes Every 10 Hours of Compressor Run Time
Electronic Timer (ADC) Defrost Up To 24 Minutes Every 6 - 72 Hours of Compressor Run Time

CONDENSER FAN MOTOR		
Watts	RPM	Amps
2.3	1100 CW Opposite Shaft	.15 Running

ICE MAKER SPECIFICATIONS		
Electrical	115 VAC (127 VAC Max)	60 Hertz
Thermostat	Opens at 48°F (9°C)	Closes at 15°F (-9°C)
Heater Wattage	165	

ICE MAKER CONNECTOR PLUG CONNECTIONS		
Wire Number	Wire Color	Connects to:
1	Green/Yellow	Ground
2	Yellow	Water Valve
3	Black	Line
4	Lt. Blue	Neutral

SERVICE DATA SHEET

STANDARD - AUTOMATIC
DEFROST TOP FREEZER MODELS (R134a) | P/N: 240379014

IMPORTANT SAFETY NOTICE

The information provided herein is designed to assist qualified repair personnel only. Untrained persons should not attempt to make repairs due to the possibility of electrical shock. Disconnect power cord before servicing.

IMPORTANT

If any green grounding wires are moved during servicing, they must be returned to their original position and properly secured.

CAUTION: All electrical parts and wiring must be shielded from torch flame. Do not allow torch to contact insulation; it will char at 200°F and flash ignite (burn) at 500°F. Excessive heat will distort the plastic liner.

NOTE: Some products come equipped with an Electronic Defrost Control. To initiate defrost, depress the fresh food light switch 5 times in 6 seconds (light bulb must be working). To terminate defrost, depress the fresh food light switch 5 times in 6 seconds.

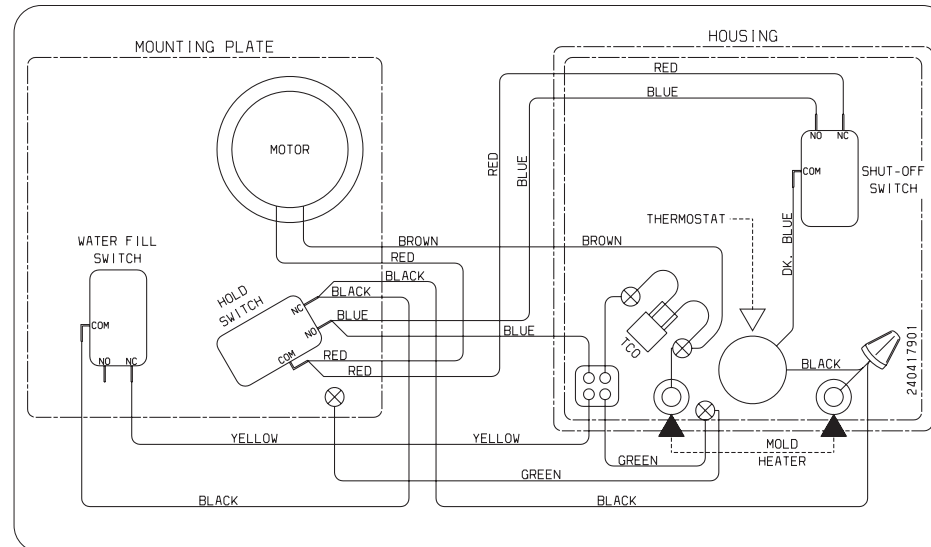

ICE MAKER INFORMATION

Test Cycling

Remove cover by inserting screwdriver in notch at bottom and prying cover from housing. Use screwdriver to rotate motor gear counterclockwise until *Holding Switch* circuit is completed. All components of ice maker should function to complete the cycle.

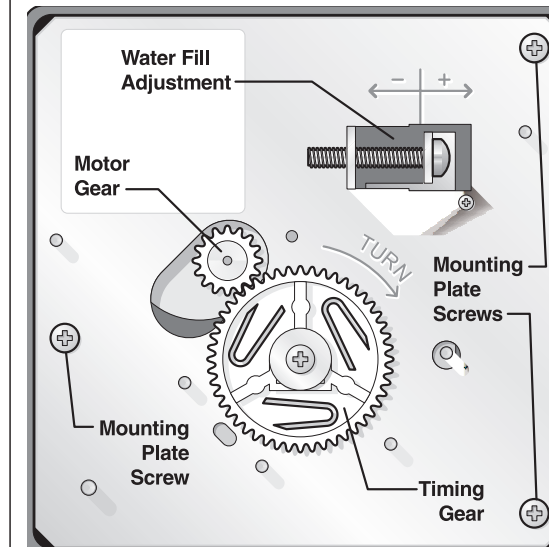

Water Fill Volume

The water fill adjustment screw will change the fill time. One full turn is equal to 20cc (.68 oz.). The correct fill is 95 to 105cc (3.2 to 3.6 oz.). When a water valve is replaced, the fill volume must be checked.

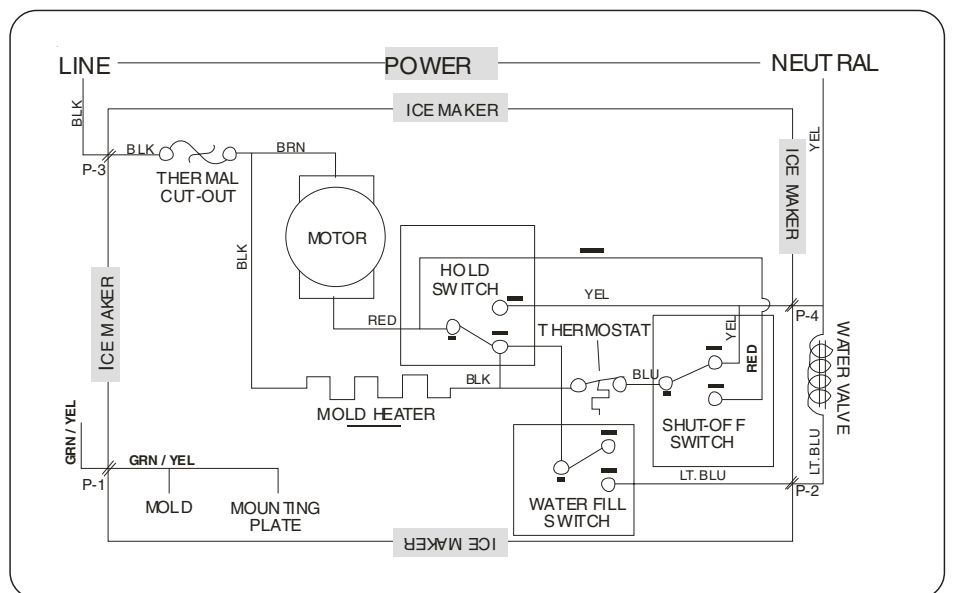

Pictorial Schematic

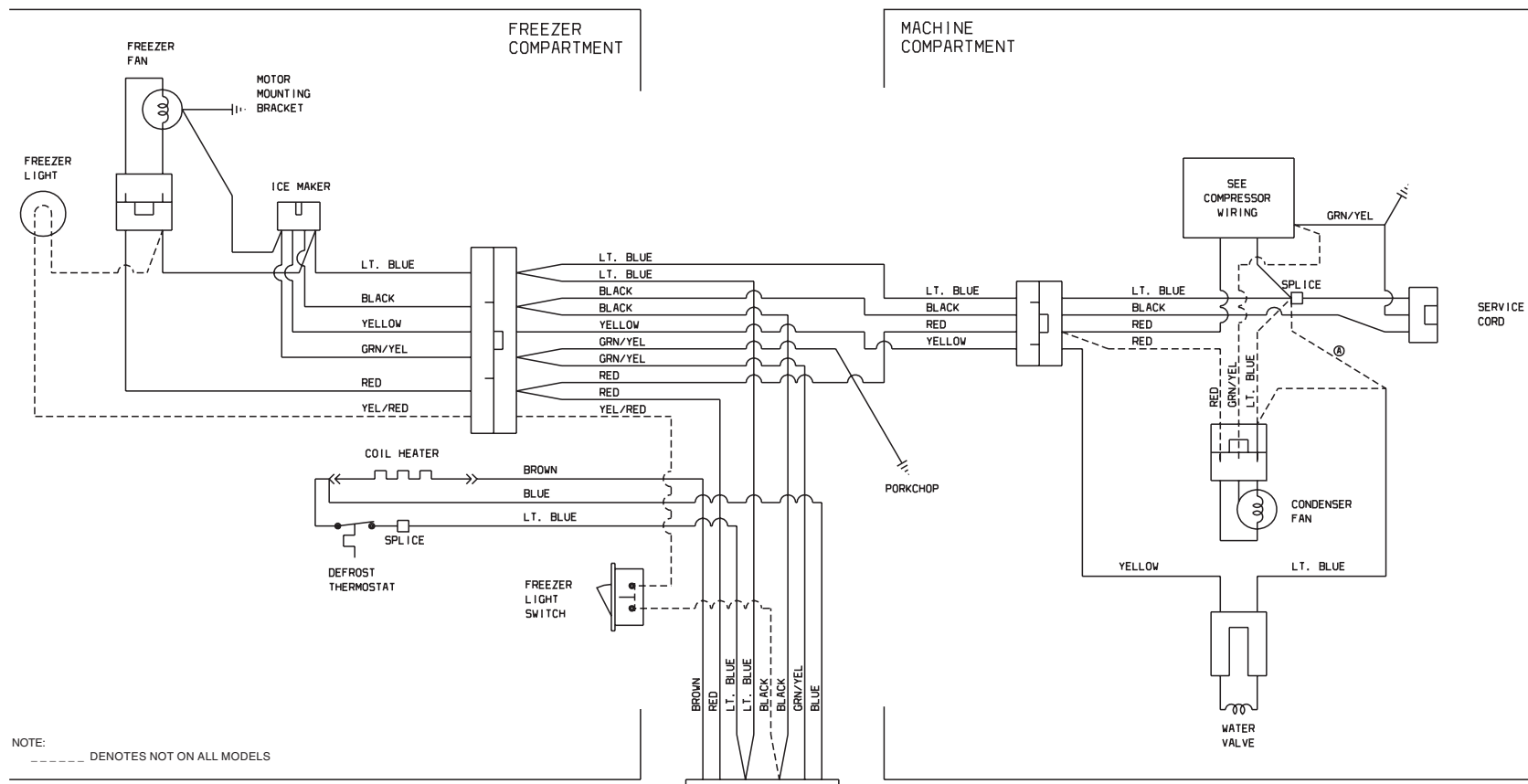

NOTE: ----- DENOTES NOT ON ALL MODELS

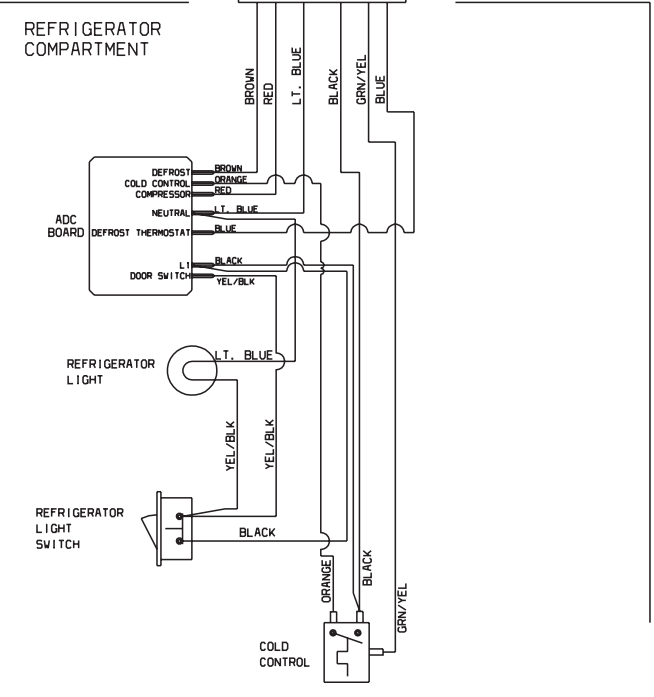
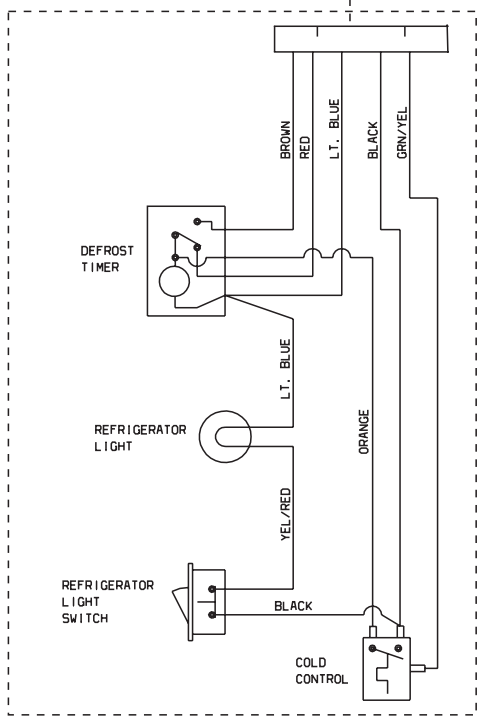

COMPRESSOR WIRING

Induction Run Compressor with Relay

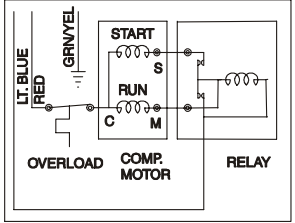

P. T. C. STARTER WITH RUN CAPACITOR

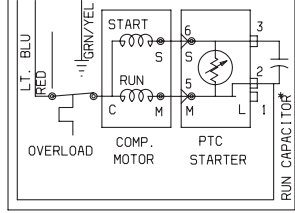

* CAPACITOR IS ONLY USED WITH SOME P. T. C. MODELS.

Ladder Schematic

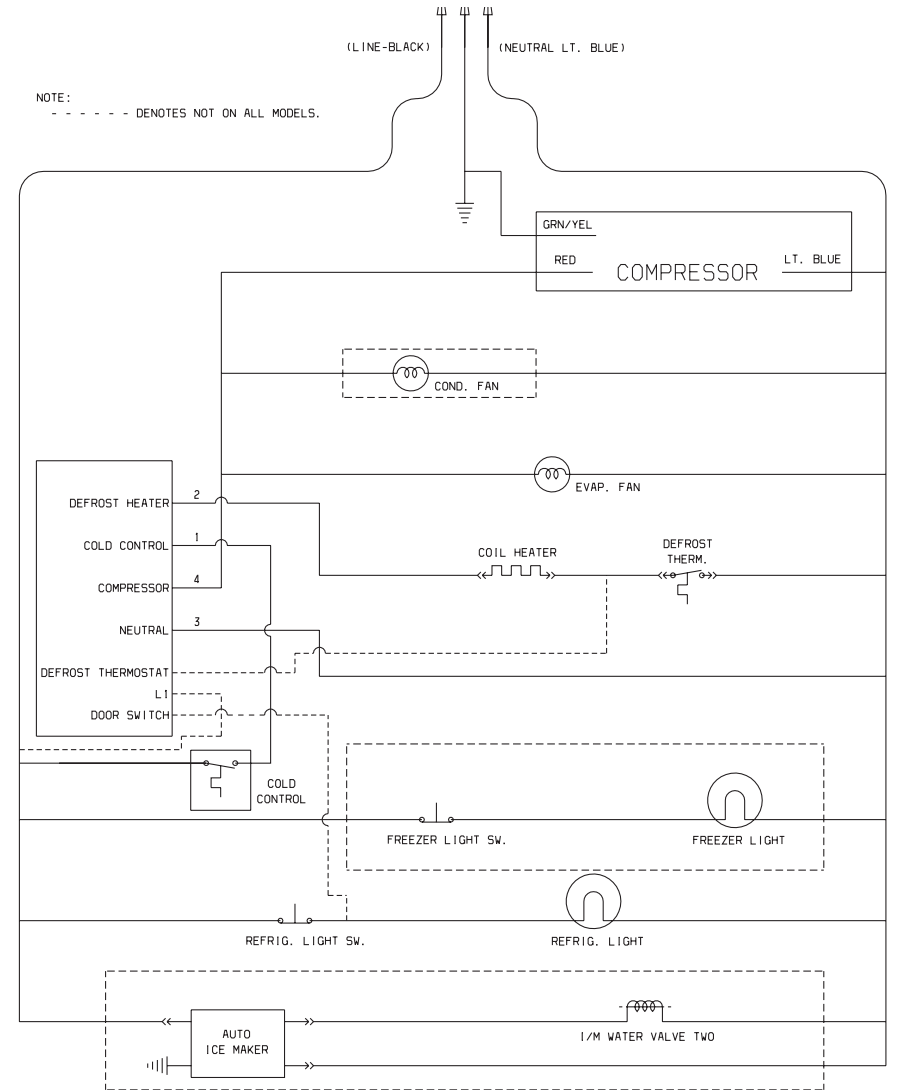

NOTE: ----- DENOTES NOT ON ALL MODELS.

SERVICE PARTS	15 & 17 CUBIC FOOT			18 CUBIC FOOT			21 CUBIC FOOT	
	STATIC	DYNAMIC	E-STAR	STATIC	DYNAMIC	E-STAR	DYNAMIC	E-STAR
Compressor / Kit *	5303918264	5303918264	5303918299	5303918297	5303918297	5303918299	5303918297	5303918299
Starter/PTC/TSD *	218721120	218721120	241527802	N/A	N/A	241527802	N/A	241527802
Run Capacitor *	218909913	218909913	218909915	N/A	N/A	218909915	N/A	218909915
Relay	N/A	N/A	N/A	5304433579	5304433579	N/A	5304433579	N/A
Overload	N/A	N/A	N/A	5304433578	5304433578	N/A	5304433578	N/A
Temperature Control	5304421256	5304421256	5304421256	5304421256	5304421256	5304421256	5304421256	5304421256
Timer (if applicable)	215846606	215846606	215846606	215846606	215846606	215846606	215846606	215846606
ADC (if applicable)	N/A	N/A	N/A	N/A	N/A	N/A	N/A	N/A
Defrost Heater Kit	5303918203	5303918203	5303918203	5303918208	5303918208	5303918208	5303918247	5303918247
Defrost Thermostat Kit	5303918202	5303918202	5303918202	5303918202	5303918202	5303918202	5303918202	5303918202
Evaporator Fan Motor	240369701	240369701	240369701	240369701	240369701	241537301	240369701	240369701
Condenser Fan Motor	N/A	240523601	240523601	N/A	240523601	240523601	240523601	241538001

* Typical compressor kit includes compressor, electrical components, and filter-drier

PERFORMANCE DATA NO LOAD AND NO DOOR OPENINGS AT MID-POINT CONTROL SETTING				
Capacitor Run or Induction Run	65°F (18°C) Ambient	90°F (32°C) Ambient		
Operating Time	25 to 35%	45 to 55%		
Freezer Temperature	2° to 8°F -17° to -13°C	0° to 5°F -18° to -15°C		
Refrigerature Temperature	35° to 40°F 2° to 4°C	35° to 40°F 2° to 4°C		
Low Side Pressure (cut-in)	8 to 16 psig 55 to 110 kPa	8 to 16 psig 55 to 110 kPa		
Low Side Pressure (cut-out)	1 to 4 psig 7 to 28 kPa	1 to 4 psig 7 to 28 kPa		
High Side Pressure (Last 1/3 of cycle)	110 to 120 psig 758 to 827 kPa	150 to 175 psig 1034 to 1207 kPa		
Wattage (Last 1/3 of cycle)	140 to 185	140 to 185		
Amps (Running)	1.1 to 1.6	1.1 to 1.6		
Base Voltage	115 VAC (127 VAC Max)	115 VAC (127 VAC Max)		
DEFROST SPECIFICATIONS				
Cabinet Size	Thermostat		Heater	
	Cut-in	Cut-out	Watts	Ohms
18' & 21'	25°F -4°C	47°F 8°C	375	35
14', 15' & 17'	25°F -4°C	47°F 8°C	325	41
Mechanical Timer - Defrost 30 Minutes Every 10 Hours of Compressor Run Time Electronic Timer (ADC) Defrost Up To 24 Minutes Every 6 - 72 Hours of Compressor Run Time				
CONDENSER FAN MOTOR				
Watts	RPM	Amps		
2.3	1100 CW Opposite Shaft	.15 Running		
ICE MAKER SPECIFICATIONS				
Electrical	115 VAC (127 VAC Max)	60 Hertz		
Thermostat	Opens at 48°F (9°C)	Closes at 15°F (-9°C)		
Heater Wattage	165			
ICE MAKER CONNECTOR PLUG CONNECTIONS				
Wire Number	Wire Color	Connects to:		
1	Green/Yellow	Ground		
2	Yellow	Water Valve		
3	Black	Line		
4	Lt. Blue	Neutral		

SERVICE DATA SHEET

STANDARD - AUTOMATIC
DEFROST TOP FREEZER
MODELS (R134a) | P/N: 240379015

IMPORTANT SAFETY NOTICE

The information provided herein is designed to assist qualified repair personnel only. Untrained persons should not attempt to make repairs due to the possibility of electrical shock. Disconnect power cord before servicing.

IMPORTANT

If any green grounding wires are moved during servicing, they must be returned to their original position and properly secured.

CAUTION: All electrical parts and wiring must be shielded from torch flame. Do not allow torch to contact insulation; it will char at 200°F and flash ignite (burn) at 500°F. Excessive heat will distort the plastic liner.

NOTE: Some products come equipped with an Electronic Defrost Control. To initiate defrost, depress the fresh food light switch 5 times in 6 seconds (light bulb must be working). To terminate defrost, depress the fresh food light switch 5 times in 6 seconds.

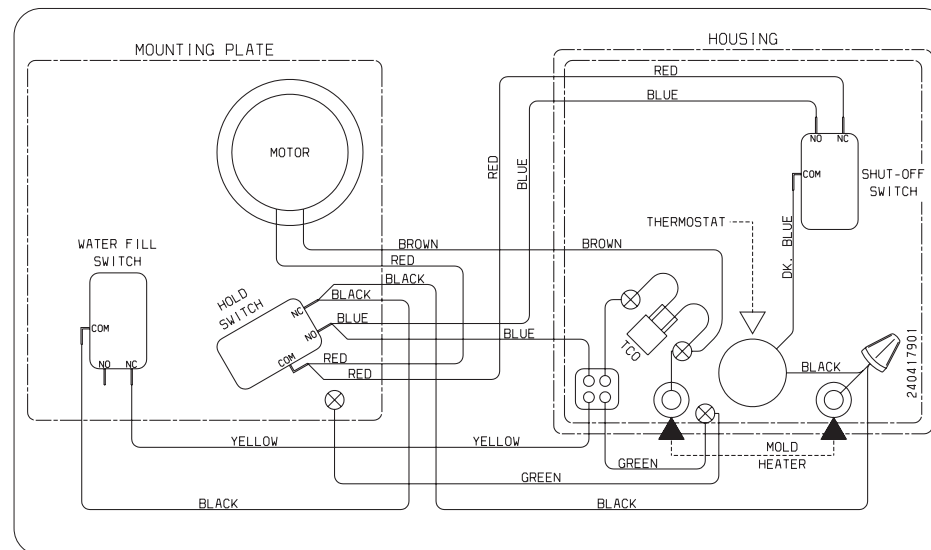

ICE MAKER INFORMATION

Test Cycling

Remove cover by inserting screwdriver in notch at bottom and prying cover from housing. Use screwdriver to rotate motor gear counterclockwise until *Holding Switch* circuit is completed. All components of ice maker should function to complete the cycle.

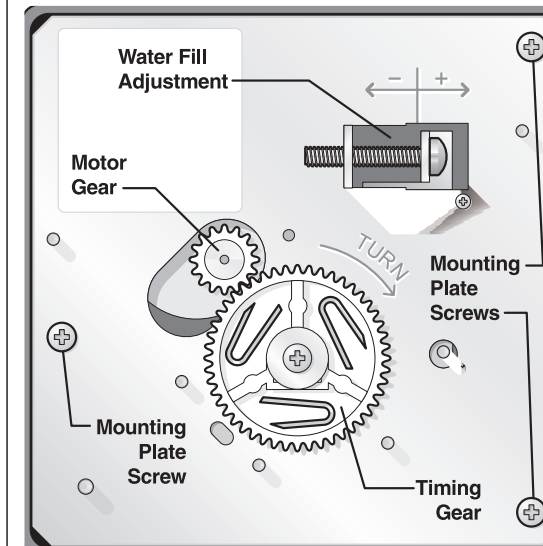

Water Fill Volume

The water fill adjustment screw will change the fill time. One full turn is equal to 20cc (.68 oz.). The correct fill is 95 to 105cc (3.2 to 3.6 oz.). When a water valve is replaced, the fill volume must be checked.

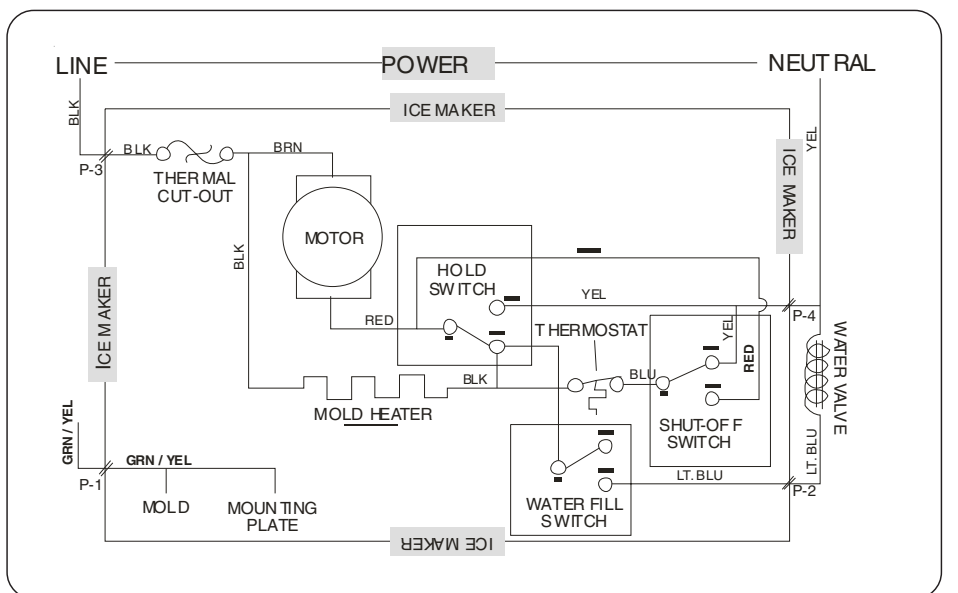

Pictorial Schematic

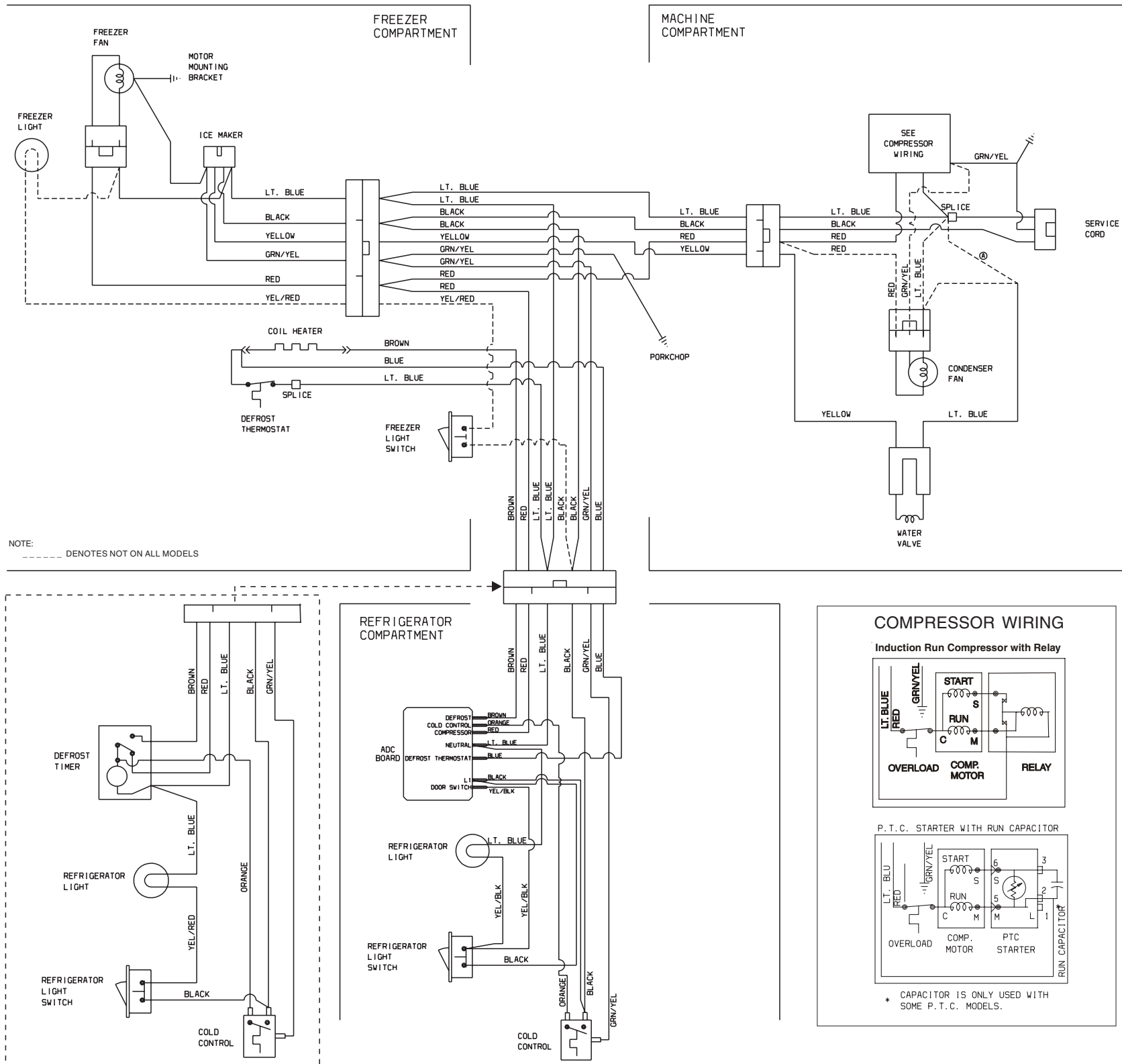

Ladder Schematic

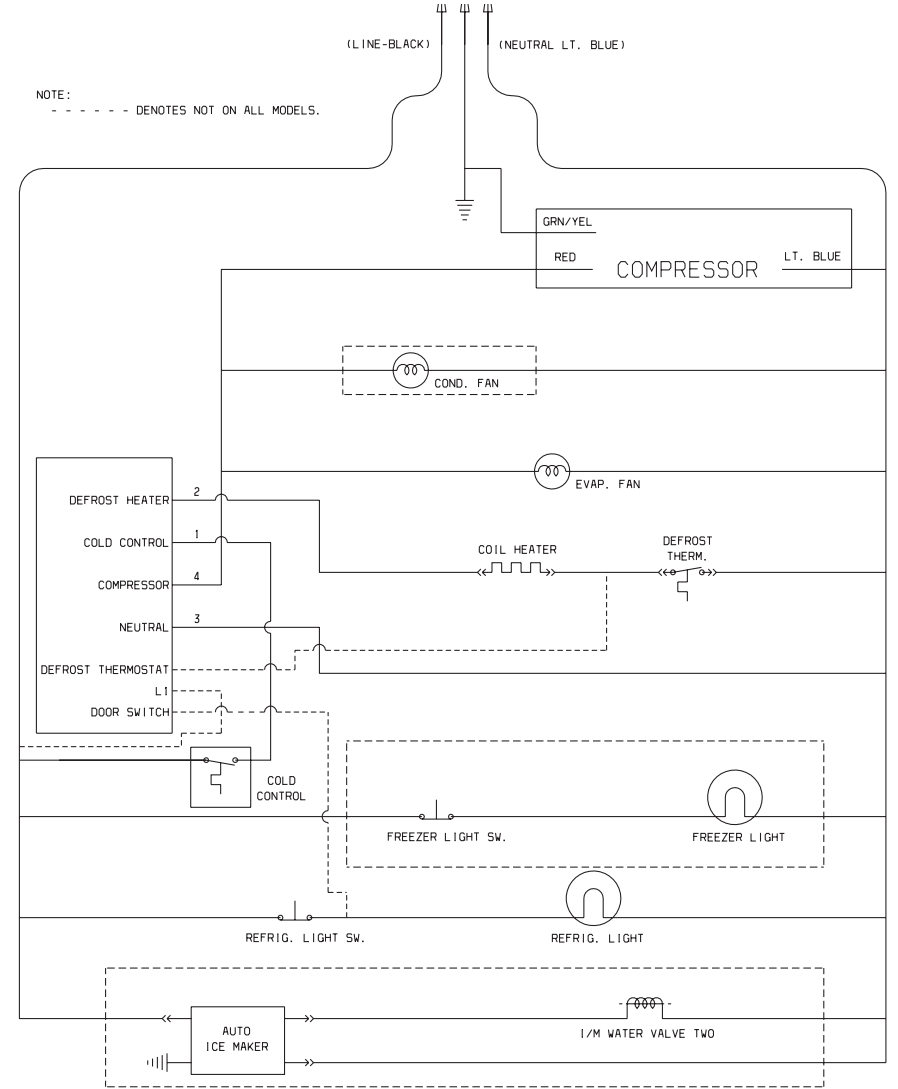

SERVICE PARTS	15 & 17 CUBIC FOOT			18 CUBIC FOOT			21 CUBIC FOOT	
	STATIC	DYNAMIC	E-STAR	STATIC	DYNAMIC	E-STAR	DYNAMIC	E-STAR
Compressor / Kit *	240550915	240550915	5303918299	240550915	240550915	5303918299	240550915	5303918299
Starter/PTC/TSD *	N/A	N/A	241527802	N/A	N/A	241527802	N/A	241527802
Run Capacitor *	N/A	N/A	218909915	N/A	N/A	218909915	N/A	218909915
Relay	5304433579	5304433579	N/A	5304433579	5304433579	N/A	5304433579	N/A
Overload	5304433578	5304433578	N/A	5304433578	5304433578	N/A	5304433578	N/A
Temperature Control	5304421256	5304421256	5304421256	5304421256	5304421256	5304421256	5304421256	5304421256
Timer (if applicable)	215846606	215846606	215846606	215846606	215846606	215846606	215846606	215846606
ADC (if applicable)	N/A	N/A	N/A	N/A	N/A	N/A	N/A	N/A
Defrost Heater Kit	5303918203	5303918203	5303918203	5303918208	5303918208	5303918208	5303918247	5303918247
Defrost Thermostat Kit	5303918202	5303918202	5303918202	5303918202	5303918202	5303918202	5303918202	5303918202
Evaporator Fan Motor	240369701	240369701	240369701	240369701	240369701	240369701	240369701	240369701
Condenser Fan Motor	N/A	240523601	240523601	N/A	240523601	240523601	240334001	240334001

* Typical compressor kit includes compressor, electrical components, and filter-drier

PERFORMANCE DATA NO LOAD AND NO DOOR OPENINGS AT MID-POINT CONTROL SETTING				
Type A With Run/Start Capacitor	65°F (18°C) Ambient	90°F (32°C) Ambient		
Operating Time	32 to 40%	55 to 65%		
Freezer Temperature	0° to 4°F -18° to -16°C	-1° to 3°F -18° to -16°C		
Refrigerator Temperature	34° to 39°F 1° to 4°C	34° to 39°F 1° to 4°C		
Low Side Pressure (cut-in)	5 to 12 psig 34 to 83 kPa	5 to 12 psig 34 to 83 kPa		
Low Side Pressure (cut-out)	-2 to 2 psig -14 to 14 kPa	-2 to 2 psig -14 to 14 kPa		
High Side Pressure (Last 1/3 of cycle)	90 to 115 psig 621 to 793 kPa	130 to 155 psig 896 to 1069 kPa		
Wattage (Last 1/3 of cycle)	120 to 150	130 to 160		
Amps (Running)	1.2 to 1.5	1.2 to 1.5		
Base Voltage	115 VAC	115 VAC		
DEFROST SPECIFICATIONS				
Cabinet Size	Thermostat		Heater	
	Cut-in	Cut-out	Watts	Ohms
23' & 26'	25°F -4°C	47°F 8°C	450	30
Electronic Timer - (ADC) Defrost 24 minutes every 6 to 72 hours of compressor run time.				
CONDENSER FAN MOTOR				
Watts	RPM	Amps		
7	1100 CW Opposite Shaft	.1 Running		
ICE MAKER SPECIFICATIONS				
Electrical	115 Volts	60 Hertz		
Thermostat	Opens at 48°F (9°C)	Closes at 15°F (-9°C)		
Heater Wattage	165			
ICE MAKER CONNECTOR PLUG CONNECTIONS				
Wire Number	Wire Color	Connects to:		
1	Green/Yellow	Ground		
2	Yellow	Water Valve		
3	Black	Line		
4	Lt. Blue	Neutral		

SERVICE DATA SHEET - 240389604
R134a
ICE & WATER - AUTOMATIC DEFROST
SIDE BY SIDE MODELS

IMPORTANT SAFETY NOTICE
The information provided herein is designed to assist qualified repair personnel only. Untrained persons should not attempt to make repairs due to the possibility of electrical shock. Disconnect power cord before servicing.

IMPORTANT
If any green grounding wires are moved during servicing, they must be returned to their original position and properly secured.

CAUTION: All electrical parts and wiring must be shielded from torch flame. Do not allow torch to contact insulation; it will char at 200°F and flash ignite (burn) at 500°F. Excessive heat will distort the plastic liner.

NOTE: This product comes equipped with an Electronic Defrost Control. To initiate defrost, depress the fresh food light switch 5 times in 6 seconds (light bulb must be working). To terminate defrost, depress the fresh food light switch 5 times in 6 seconds.

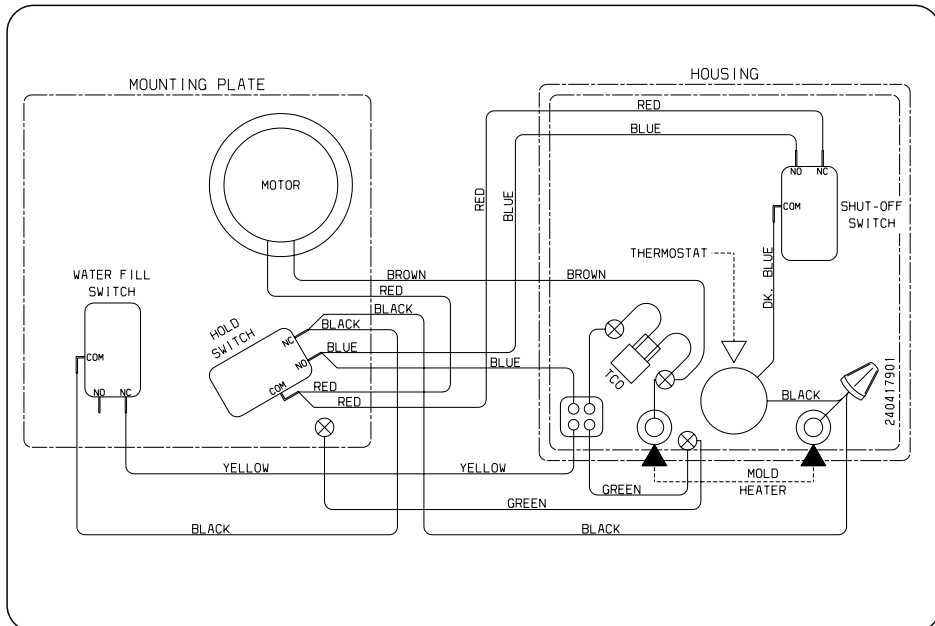

ICE MAKER INFORMATION

Test Cycling

Remove cover by inserting screwdriver in notch at bottom and prying cover from housing. Use screwdriver to rotate motor gear counterclockwise until holding switch circuit is completed. All components of ice maker should function to complete the cycle.

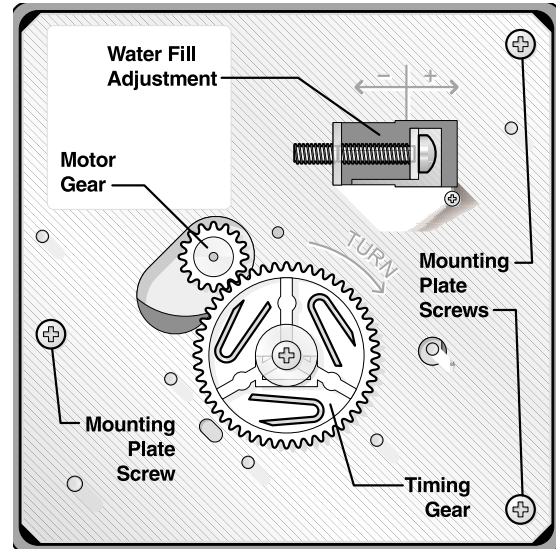

Water Fill Volume

The water fill adjustment screw will change the fill time. One full turn is equal to 20cc (.68 oz.). The correct fill is 102 to 130cc (3.4 to 4.3 oz.). When a water valve is replaced, the fill volume must be checked.

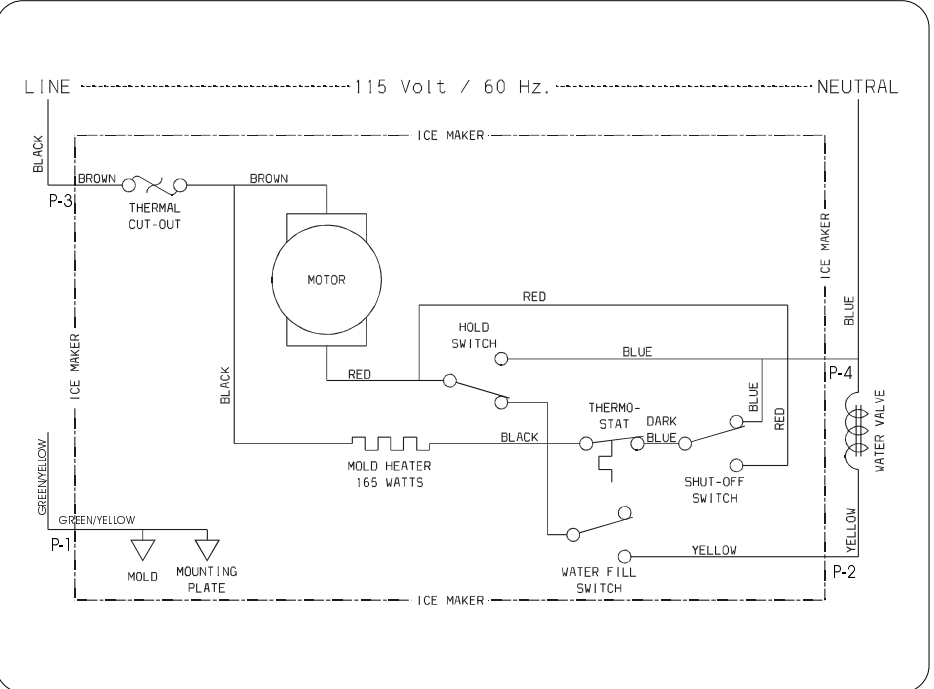

Pictorial Schematic

5.50

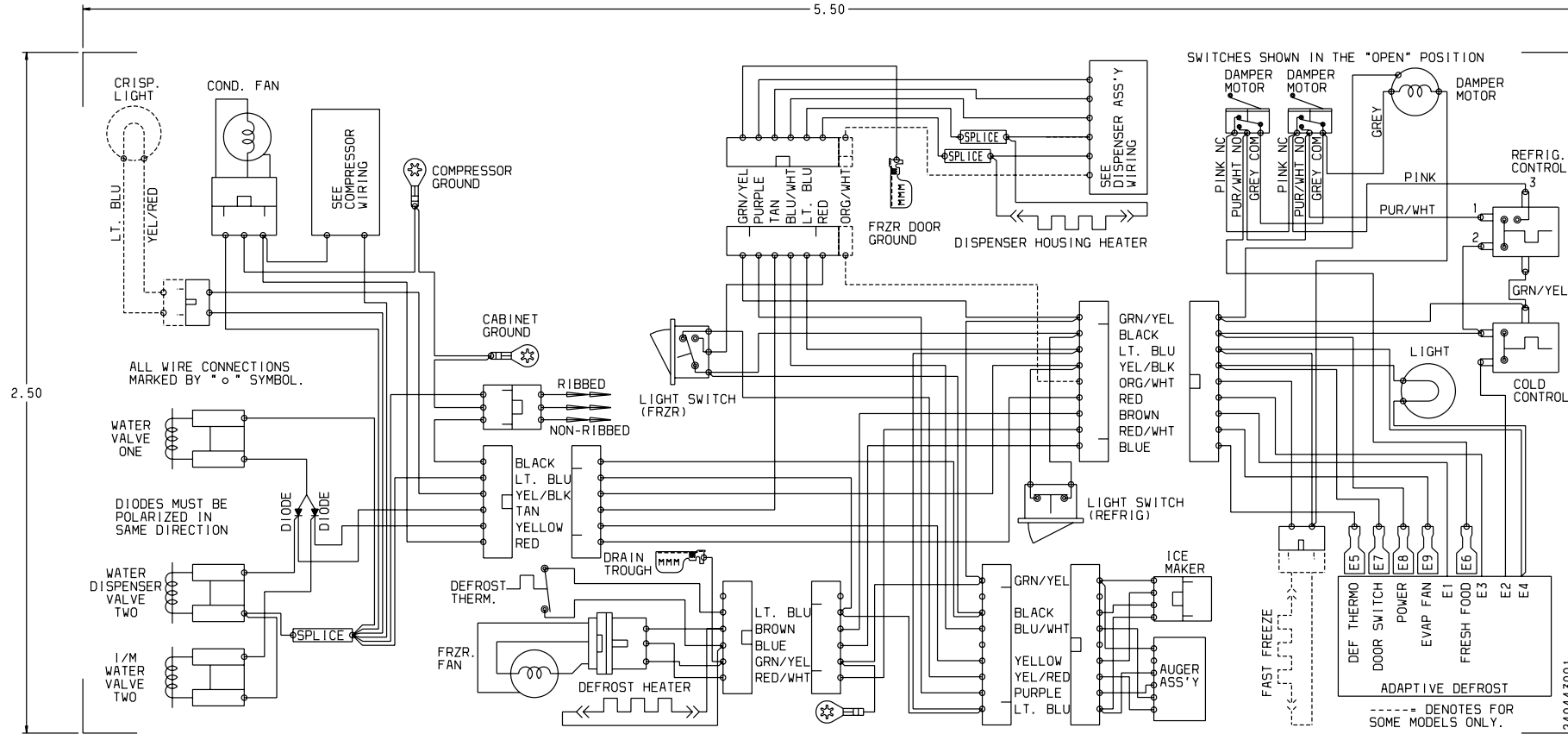

Ladder Schematic

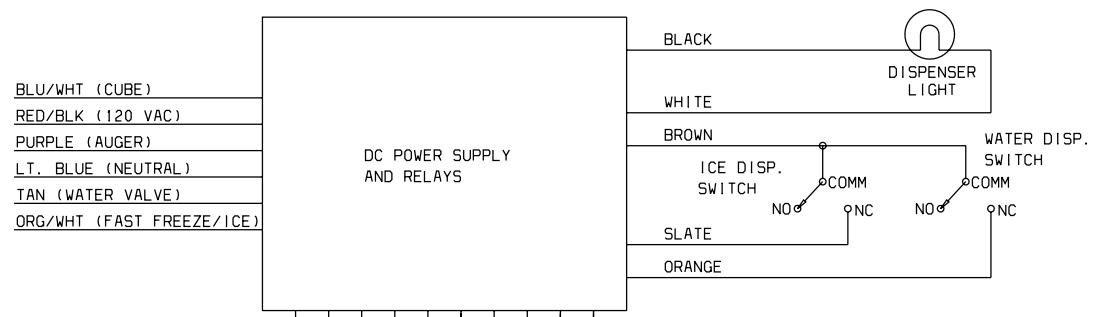
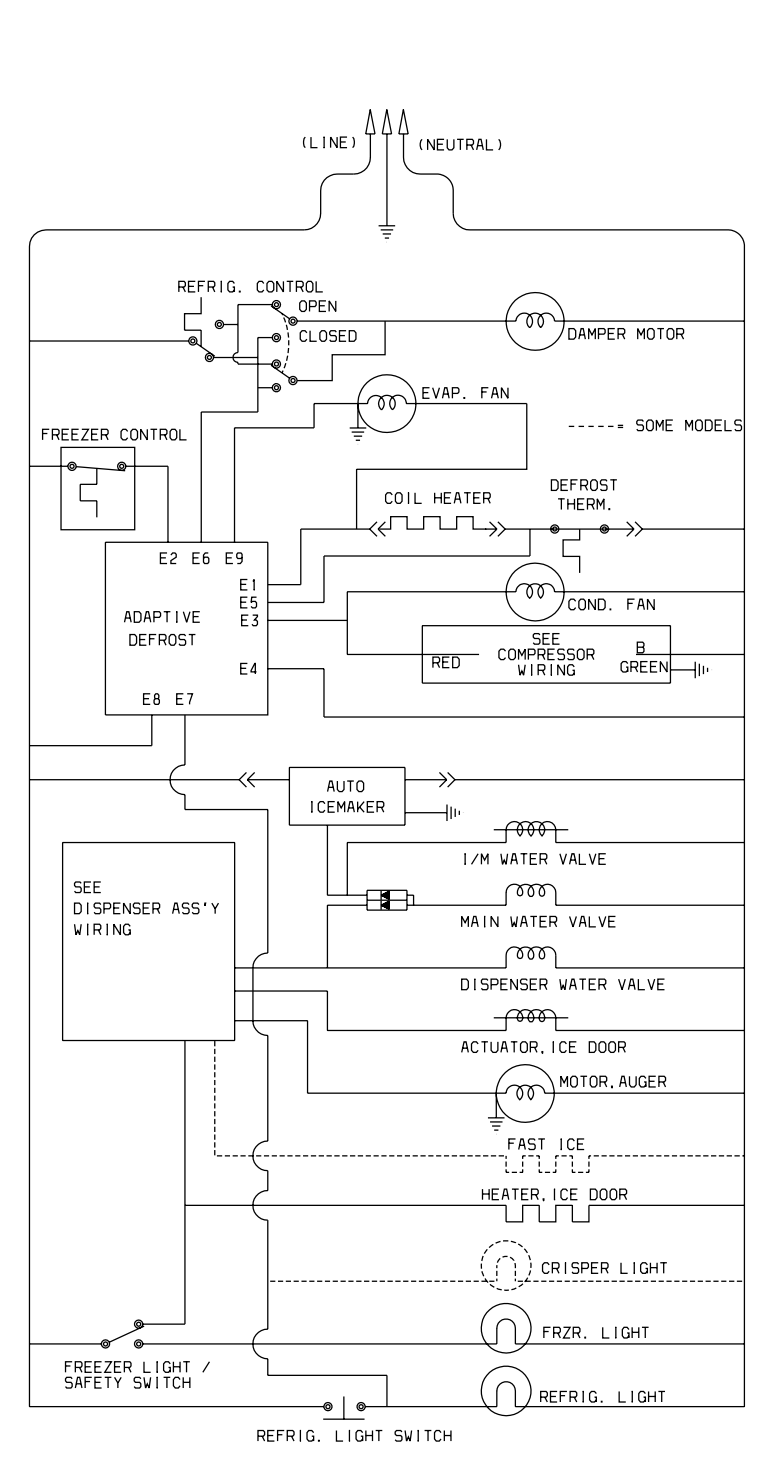

Electro-Mechanical Dispenser

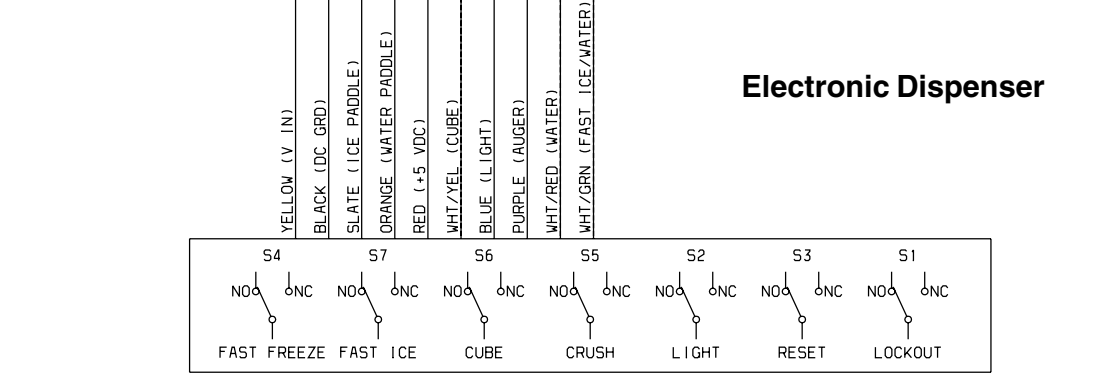
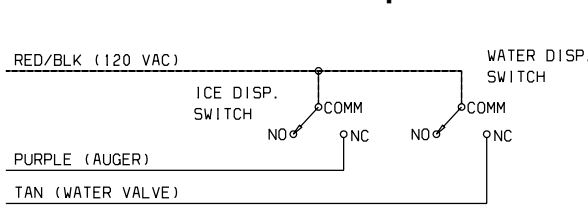

Electronic Dispenser

Compressor Wiring

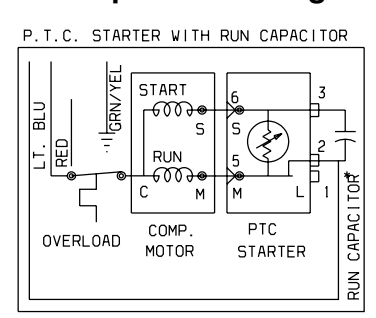

* CAPACITOR IS ONLY USED WITH SOME P.T.C. MODELS.

PERFORMANCE DATA NO LOAD AND NO DOOR OPENINGS AT MID-POINT CONTROL SETTING				
Type A With Run/Start Capacitor	65°F (18°C) Ambient	90°F (32°C) Ambient		
Operating Time	32 to 40%	55 to 65%		
Freezer Temperature	0° to 4°F -18° to -16°C	-1° to 3°F -18° to -16°C		
Refrigerator Temperature	34° to 39°F 1° to 4°C	34° to 39°F 1° to 4°C		
Low Side Pressure (cut-in)	5 to 12 psig 34 to 83 kPa	5 to 12 psig 34 to 83 kPa		
Low Side Pressure (cut-out)	-2 to 2 psig -14 to 14 kPa	-2 to 2 psig -14 to 14 kPa		
High Side Pressure (Last 1/3 of cycle)	90 to 115 psig 621 to 793 kPa	130 to 155 psig 896 to 1069 kPa		
Wattage (Last 1/3 of cycle)	120 to 150	130 to 160		
Amps (Running)	1.2 to 1.5	1.2 to 1.5		
Base Voltage	115 vac (127 vac max)	115 vac (127 vac max)		
DEFROST SPECIFICATIONS				
Cabinet Size	Thermostat		Heater	
	Cut-in	Cut-out	Watts	Ohms
23' & 26'	25°F -4°C	47°F 8°C	450	30
Electronic Timer - (ADC) Defrost 24 minutes every 6 to 72 hours of compressor run time.				
CONDENSER FAN MOTOR				
Watts	RPM	Amps		
7	1100 CW Opposite Shaft	.1 Running		
ICE MAKER SPECIFICATIONS				
Electrical	115 vac (127 vac max)	60 Hertz		
Thermostat	Opens at 48°F (9°C)	Closes at 15°F (-9°C)		
Heater Wattage	165			
ICE MAKER CONNECTOR PLUG CONNECTIONS				
Wire Number	Wire Color	Connects to:		
1	Green/Yellow	Ground		
2	Yellow	Water Valve		
3	Black	Line		
4	Lt. Blue	Neutral		

SERVICE DATA SHEET - 240389616

R134a ICE & WATER - AUTOMATIC DEFROST SIDE BY SIDE MODELS

IMPORTANT SAFETY NOTICE

The information provided herein is designed to assist qualified repair personnel only. Untrained persons should not attempt to make repairs due to the possibility of electrical shock. Disconnect power cord before servicing.

IMPORTANT

If any green grounding wires are moved during servicing, they must be returned to their original position and properly secured.

CAUTION: All electrical parts and wiring must be shielded from torch flame. Do not allow torch to contact insulation; it will char at 200°F and flash ignite (burn) at 500°F. Excessive heat will distort the plastic liner.

NOTE: This product comes equipped with an Electronic Defrost Control. To initiate defrost, depress the fresh food light switch 5 times in 6 seconds (light bulb must be working). To terminate defrost, depress the fresh food light switch 5 times in 6 seconds.

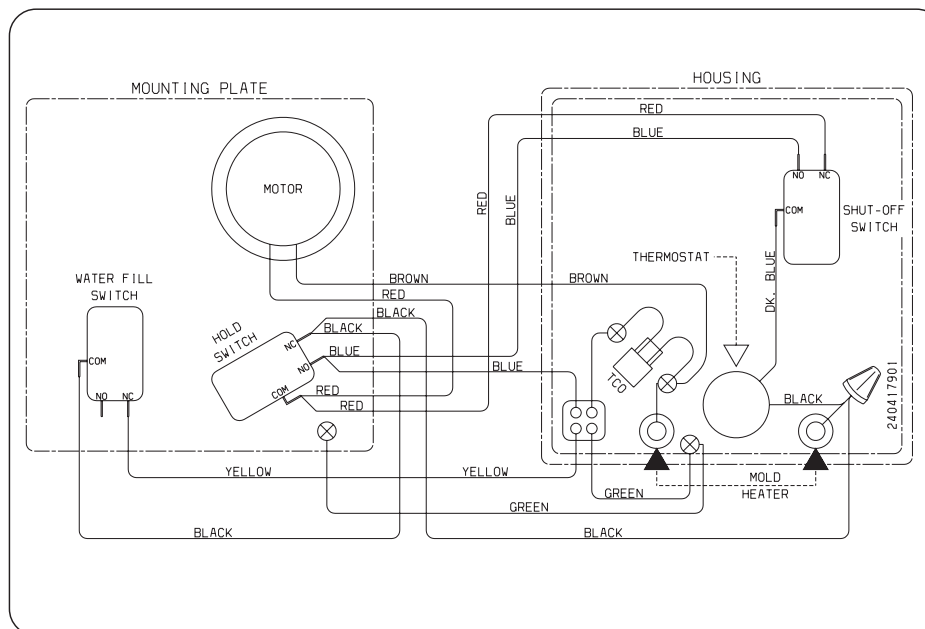

ICE MAKER INFORMATION

Test Cycling

Remove cover by inserting screwdriver in notch at bottom and prying cover from housing. Use screwdriver to rotate motor gear counterclockwise until holding switch circuit is completed. All components of ice maker should function to complete the cycle.

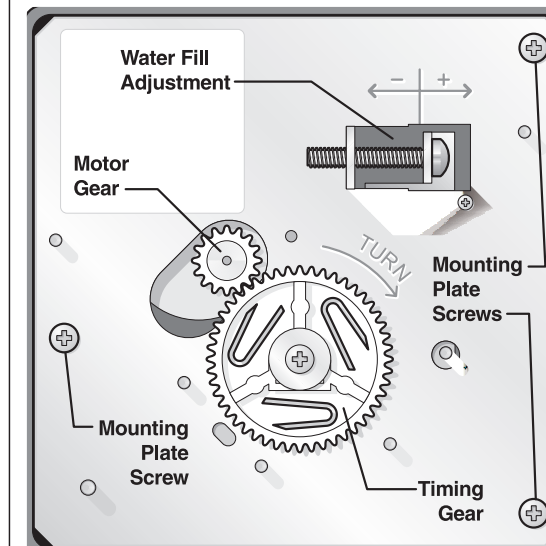

Water Fill Volume

The water fill adjustment screw will change the fill time. One full turn is equal to 20cc (.68 oz.). The correct fill is 102 to 130cc (3.4 to 4.3 oz.). When a water valve is replaced, the fill volume must be checked.

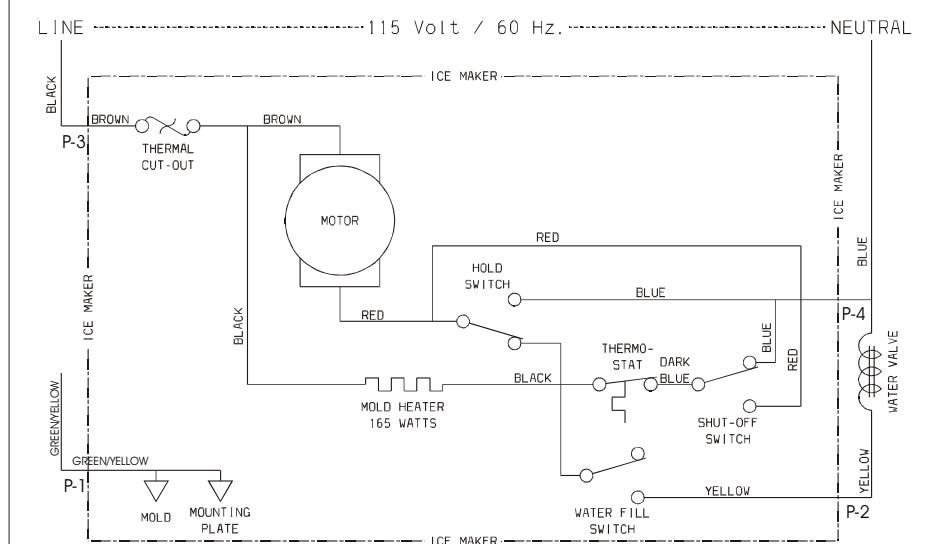

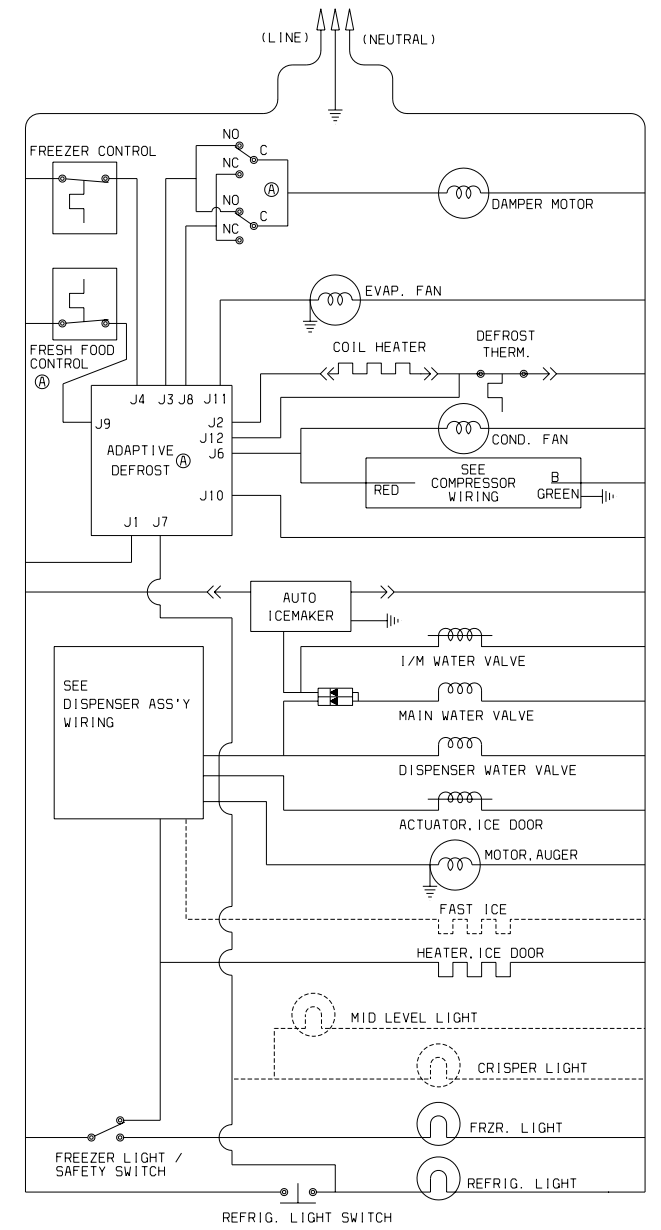
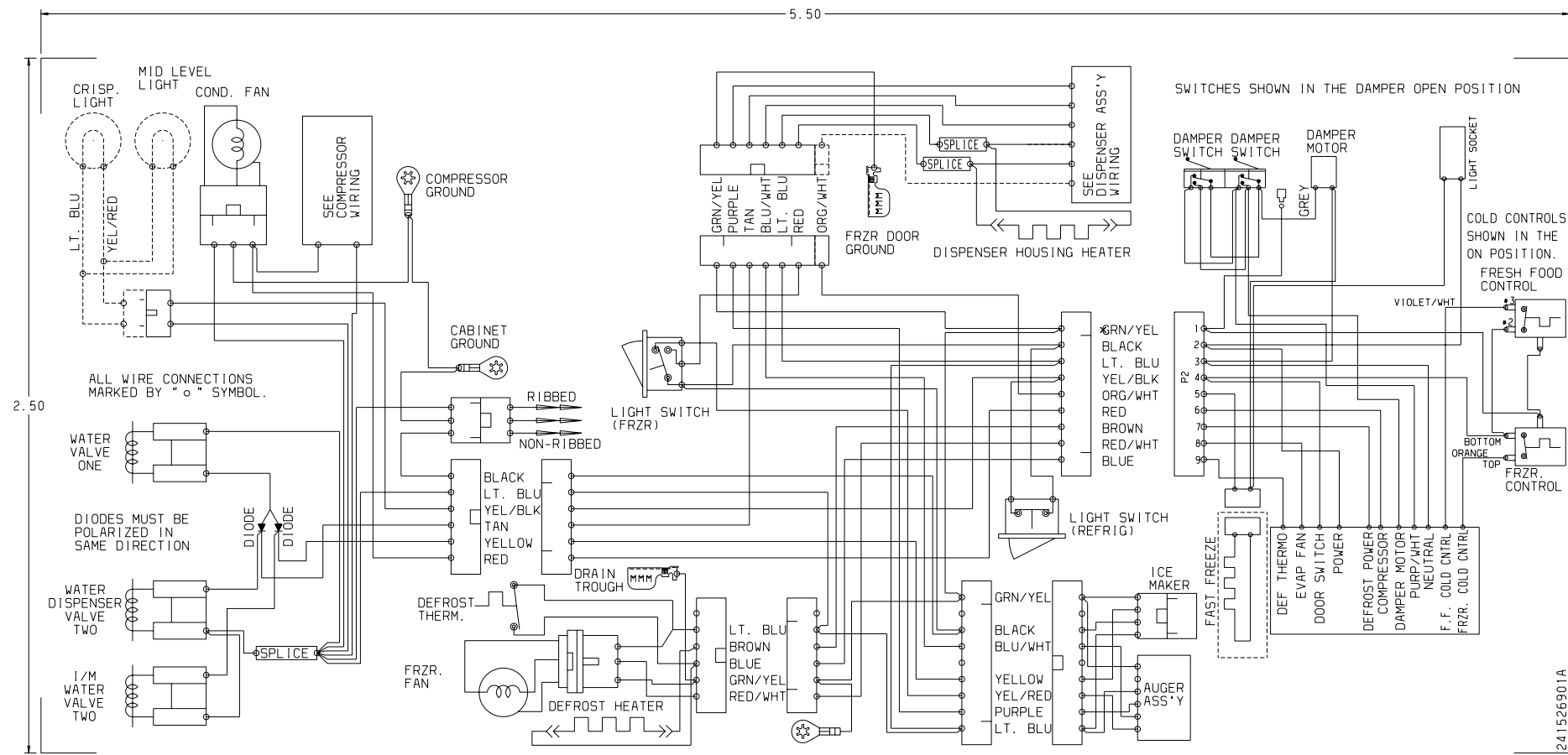

A-12

ELECTRONIC DISPENSER

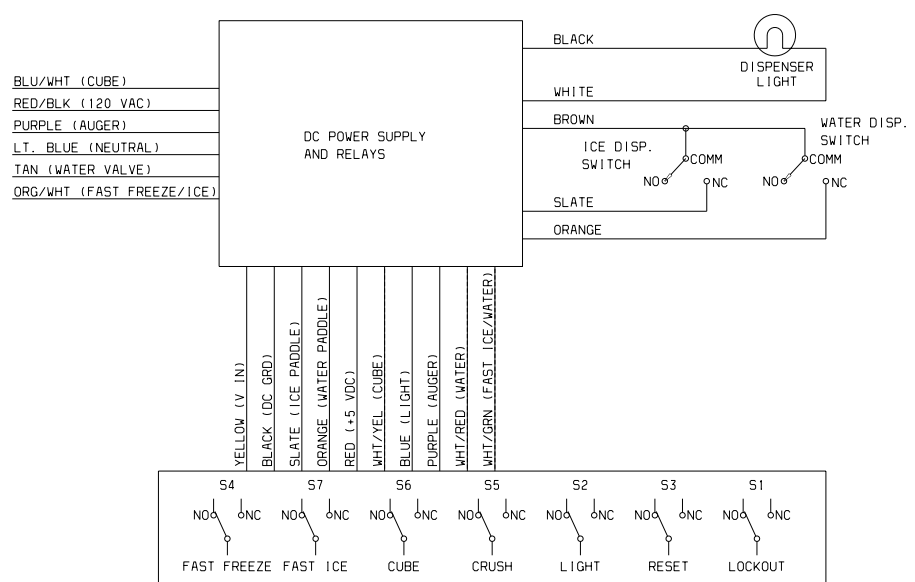

ELECTRO-MECHANICAL DISPENSER

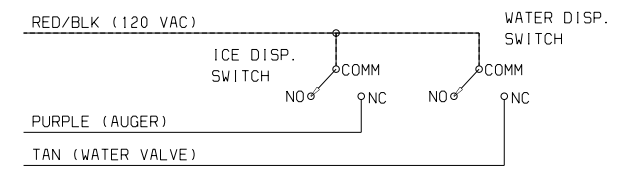

P. T. C. STARTER WITH RUN CAPACITOR

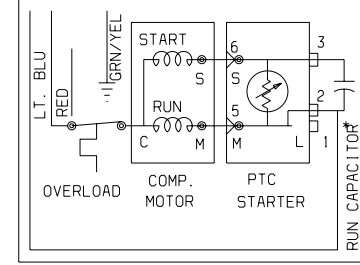

* CAPACITOR IS ONLY USED WITH SOME P. T. C. MODELS.

SERVICE PARTS	23 CUBIC FOOT		26 CUBIC FOOT	
	STANDARD	E-STAR	STANDARD	E-STAR
Compressor Kit *	5303918303	5303918299	5303918303	5303918298
Starter/PTC/TSD *	241524604	241527802	241524604	241527801
Run Capacitor *	218909913	218909915	218909913	218909915
Temp. Control-Refr	241507701	241507701	241507701	241507701
Temp. Control-Frzzr	450226-07	450226-07	450226-07	450226-07
Timer (if applicable)	N/A	N/A	N/A	N/A
ADC (if applicable)	241508001	241508001	241508001	241508001
Defrost Heater Kit	5303918253	5303918253	5303918253	5303918253
Defrost Thermostat Kit	5303918214	5303918214	5303918214	5303918214
Evaporator Fan Motor	240369701	240369701	240369701	241537301
Condenser Fan Motor	240523601	241538001	240523601	241538001

* Typical compressor kit includes compressor, electrical components, and filter-drier

**PERFORMANCE DATA
NO LOAD AND NO DOOR OPENINGS AT MID-POINT CONTROL SETTING**

Type A With Run/Start Capacitor	65°F (18°C) Ambient	90°F (32°C) Ambient
Operating Time	32 to 40%	55 to 65%
Freezer Temperature	0° to 4°F -18° to -16°C	-1° to 3°F -18° to -16°C
Refrigerator Temperature	34° to 39°F 1° to 4°C	34° to 39°F 1° to 4°C
Low Side Pressure (cut-in)	5 to 12 psig 34 to 83 kPa	5 to 12 psig 34 to 83 kPa
Low Side Pressure (cut-out)	-2 to 2 psig -14 to 14 kPa	-2 to 2 psig -14 to 14 kPa
High Side Pressure (Last 1/3 of cycle)	90 to 115 psig 621 to 793 kPa	130 to 155 psig 896 to 1069 kPa
Wattage (Last 1/3 of cycle)	120 to 150	130 to 160
Amps (Running)	1.2 to 1.5	1.2 to 1.5
Base Voltage	115 vac (127 vac max)	115 vac (127 vac max)

DEFROST SPECIFICATIONS

Cabinet Size	Thermostat		Heater	
	Cut-in	Cut-out	Watts	Ohms
23' & 26'	25°F -4°C	47°F 8°C	450	30

Electronic Timer - (ADC) Defrost 24 minutes every 6 to 72 hours of compressor run time.

CONDENSER FAN MOTOR

Watts	RPM	Amps
7	1100 CW Opposite Shaft	.1 Running

ICE MAKER SPECIFICATIONS

Electrical	115 vac (127 vac max)	60 Hertz
Thermostat	Opens at 48°F (9°C)	Closes at 15°F (-9°C)
Heater Wattage	165	

ICE MAKER CONNECTOR PLUG CONNECTIONS

Wire Number	Wire Color	Connects to:
1	Green/Yellow	Ground
2	Yellow	Water Valve
3	Black	Line
4	Lt. Blue	Neutral

SERVICE DATA SHEET - 240389618

**R134a
ICE & WATER - AUTOMATIC DEFROST
SIDE BY SIDE MODELS**

IMPORTANT SAFETY NOTE

The information provided herein is designed to assist qualified repair personnel only. Untrained persons should not attempt to make repairs due to the possibility of electrical shock. Disconnect power cord before servicing this appliance.

IMPORTANT

If any green grounding wires are removed during servicing, they must be returned to their original position and properly secured.

CAUTION

All electrical parts and wiring must be shielded from torch flame. DO NOT allow torch to touch insulation; it will char at 200°F and flash ignite (burn) at 500°F. Excessive heat will distort the plastic liner.

NOTE

This product comes equipped with an Electronic Defrost Control. To initiate defrost, depress the fresh food light switch 5 times in 6 seconds (light bulb must be working). To terminate defrost, depress the fresh food light switch 5 times in 6 seconds.

ICE MAKER INFORMATION

Test Cycling

Press the momentary contact on the ON/OFF switch for approximately 15 seconds. Ice maker will continue to complete the cycle.

Water Fill Volume

Remove cover by inserting screwdriver in notch at bottom and prying cover from housing. The water fill adjustment screw will change the fill time. One turn is equal to 20cc (.68 oz.). The correct fill is 102 to 110cc (3.25 to 3.5 oz.). When a water valve is replaced, the fill volume must be checked

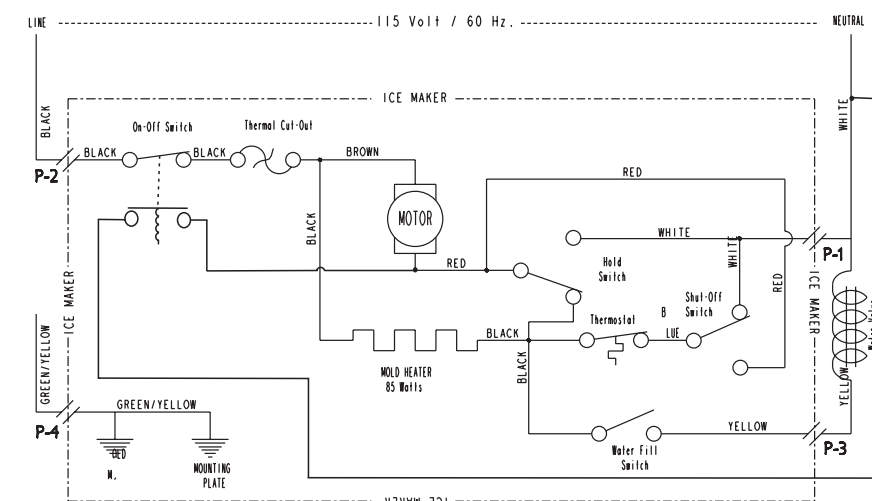
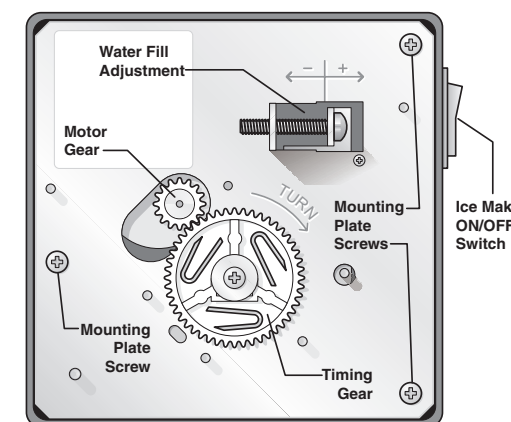

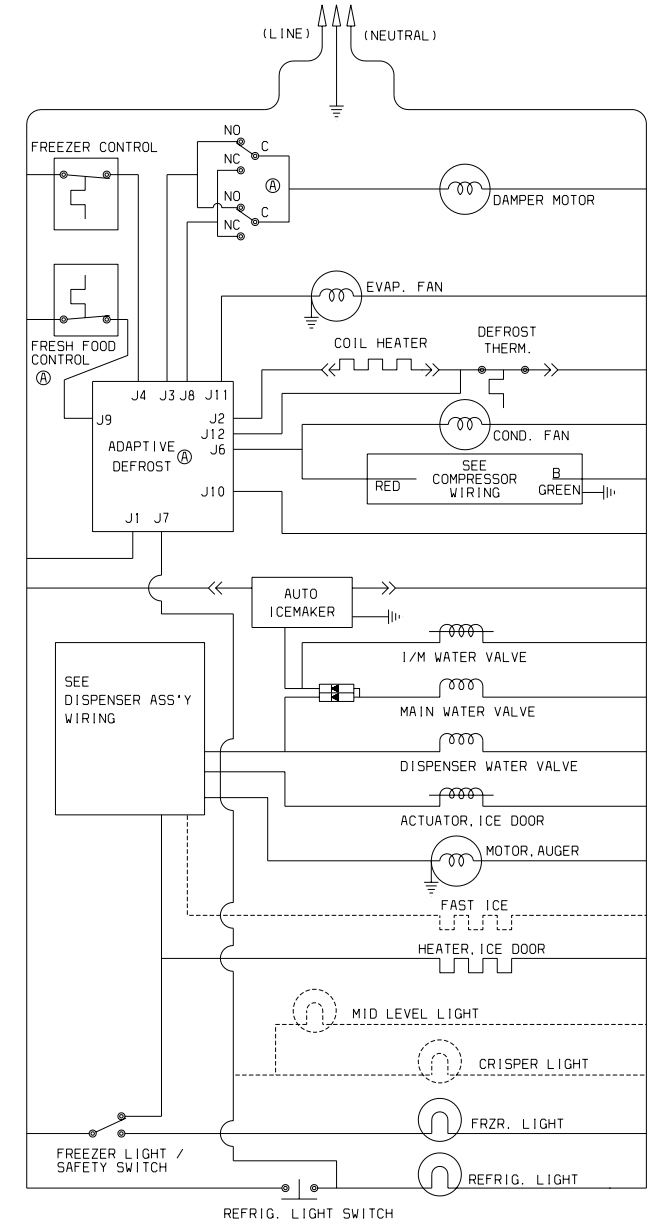
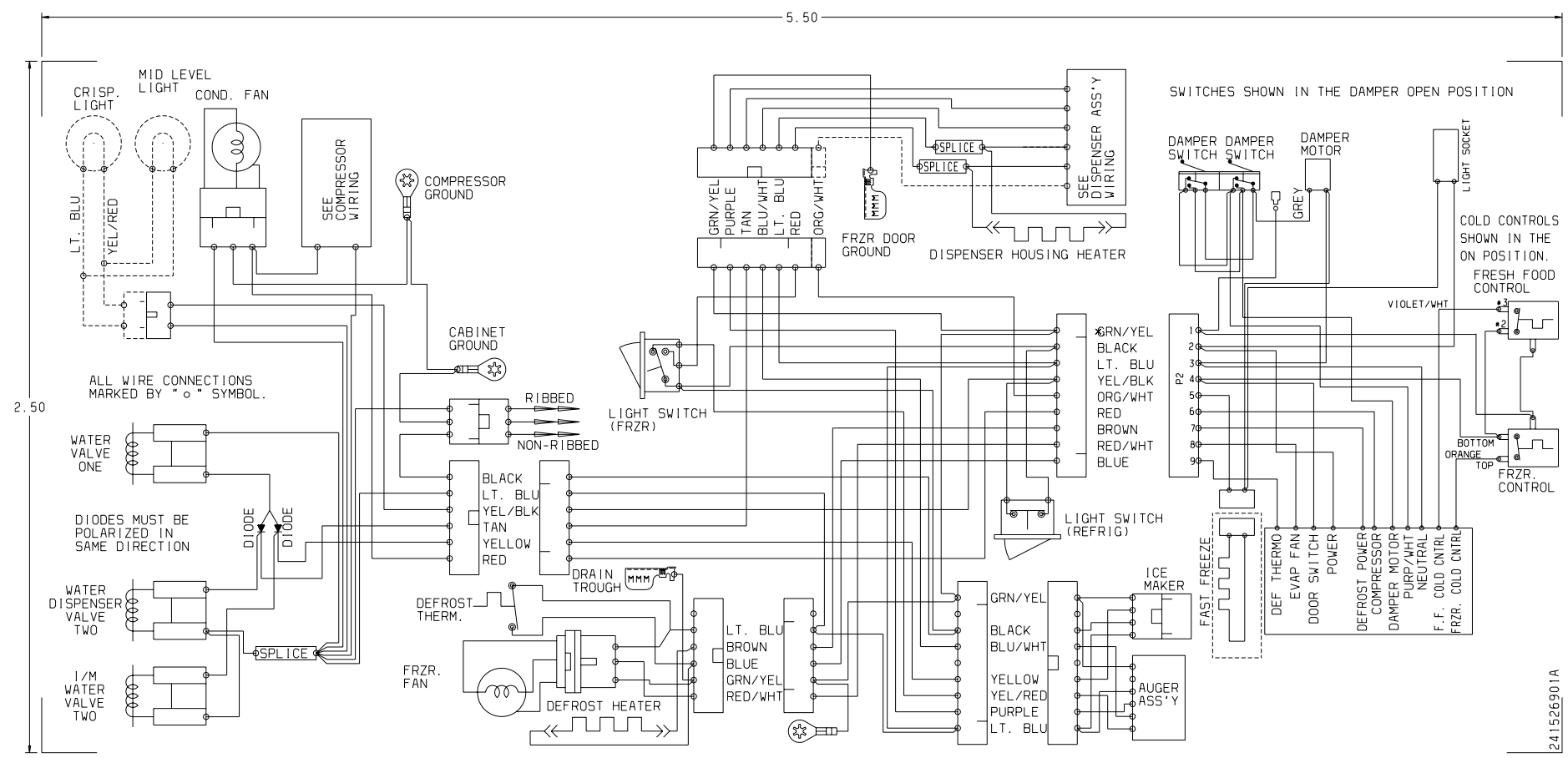

ELECTRONIC DISPENSER

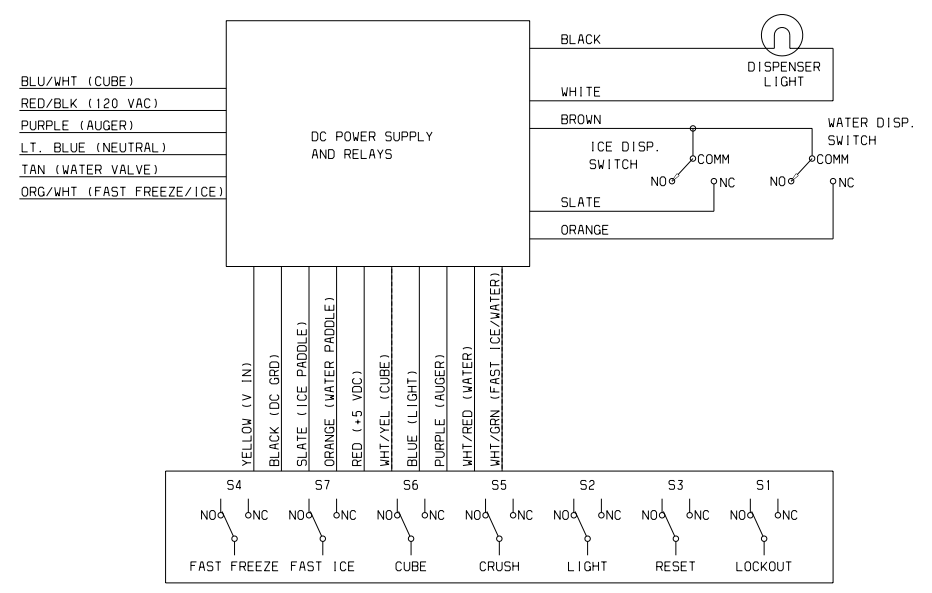

ELECTRO-MECHANICAL DISPENSER

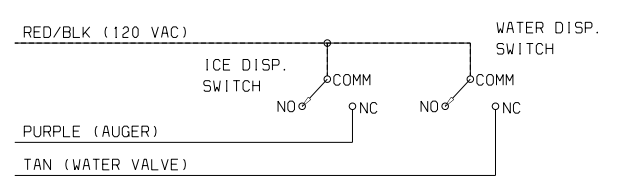

P. T. C. STARTER WITH RUN CAPACITOR

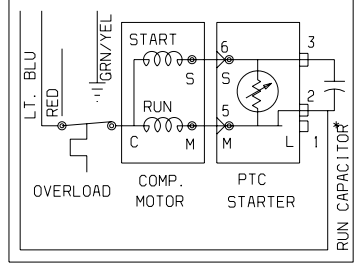

* CAPACITOR IS ONLY USED WITH SOME P. T. C. MODELS.

SERVICE PARTS	23 CUBIC FOOT		26 CUBIC FOOT	
	STANDARD	E-STAR	STANDARD	E-STAR
Compressor Kit *	5303918303	5303918299	5303918303	5303918298
Starter/PTC/TSD *	241524604	241527802	241524604	241527801
Run Capacitor *	218909913	218909915	218909913	218909915
Temp. Control-Refr	241507701	241507701	241507701	241507701
Temp. Control-Frزر	450226-07	450226-07	450226-07	450226-07
Timer (if applicable)	N/A	N/A	N/A	N/A
ADC (if applicable)	241508001	241508001	241508001	241508001
Defrost Heater Kit	5303918253	5303918253	5303918253	5303918253
Defrost Thermostat Kit	5303918214	5303918214	5303918214	5303918214
Evaporator Fan Motor	240369701	240369701	240369701	241537301
Condenser Fan Motor	240523601	241538001	240523601	241538001

* Typical compressor kit includes compressor, electrical components, and filter-drier

PERFORMANCE DATA NO LOAD AND NO DOOR OPENINGS AT MID-POINT CONTROL SETTING				
Type A With Run/Start Capacitor	65°F (18°C) Ambient	90°F (32°C) Ambient		
Operating Time	32 to 40%	55 to 65%		
Freezer Temperature	0° to 4°F -18° to -16°C	-1° to 3°F -18° to -16°C		
Refrigerator Temperature	34° to 39°F 1° to 4°C	34° to 39°F 1° to 4°C		
Low Side Pressure (cut-in)	5 to 12 psig 34 to 83 kPa	5 to 12 psig 34 to 83 kPa		
Low Side Pressure (cut-out)	-2 to 2 psig -14 to 14 kPa	-2 to 2 psig -14 to 14 kPa		
High Side Pressure (Last 1/3 of cycle)	90 to 115 psig 621 to 793 kPa	130 to 155 psig 896 to 1069 kPa		
Wattage (Last 1/3 of cycle)	120 to 150	130 to 160		
Amps (Running)	1.2 to 1.5	1.2 to 1.5		
Base Voltage	115 vac (127 vac max)	115 vac (127 vac max)		
DEFROST SPECIFICATIONS				
Cabinet Size	Thermostat		Heater	
	Cut-in	Cut-out	Watts	Ohms
23' & 26'	25°F -4°C	47°F 8°C	450	30
Electronic Timer - (ADC) Defrost 24 minutes every 6 to 72 hours of compressor run time.				
CONDENSER FAN MOTOR				
Watts	RPM	Amps		
7	1100 CW Opposite Shaft	.1 Running		
ICE MAKER SPECIFICATIONS				
Electrical	115 vac (127 vac max)	60 Hertz		
Thermostat	Opens at 48°F (9°C)	Closes at 15°F (-9°C)		
Heater Wattage	165			
ICE MAKER CONNECTOR PLUG CONNECTIONS				
Wire Number	Wire Color	Connects to:		
1	Green/Yellow	Ground		
2	Yellow	Water Valve		
3	Black	Line		
4	Lt. Blue	Neutral		

SERVICE DATA SHEET - 240389620
R134a
ICE & WATER - AUTOMATIC DEFROST
SIDE BY SIDE MODELS

IMPORTANT SAFETY NOTE

The information provided herein is designed to assist qualified repair personnel only. Untrained persons should not attempt to make repairs due to the possibility of electrical shock. Disconnect power cord before servicing this appliance.

IMPORTANT

If any green grounding wires are removed during servicing, they must be returned to their original position and properly secured.

CAUTION

All electrical parts and wiring must be shielded from torch flame. DO NOT allow torch to touch insulation; it will char at 200°F and flash ignite (burn) at 500°F. Excessive heat will distort the plastic liner.

NOTE

This product comes equipped with an Electronic Defrost Control. To initiate defrost, depress the fresh food light switch 5 times in 6 seconds (light bulb must be working). To terminate defrost, depress the fresh food light switch 5 times in 6 seconds.

ICE MAKER INFORMATION

Test Cycling

Press the momentary contact on the ON/OFF switch for approximately 15 seconds. Ice maker will continue to complete the cycle.

Water Fill Volume

Remove cover by inserting screwdriver in notch at bottom and prying cover from housing. The water fill adjustment screw will change the fill time. One turn is equal to 20cc (.68 oz.). The correct fill is 102 to 110cc (3.25 to 3.5 oz.). When a water valve is replaced, the fill volume must be checked

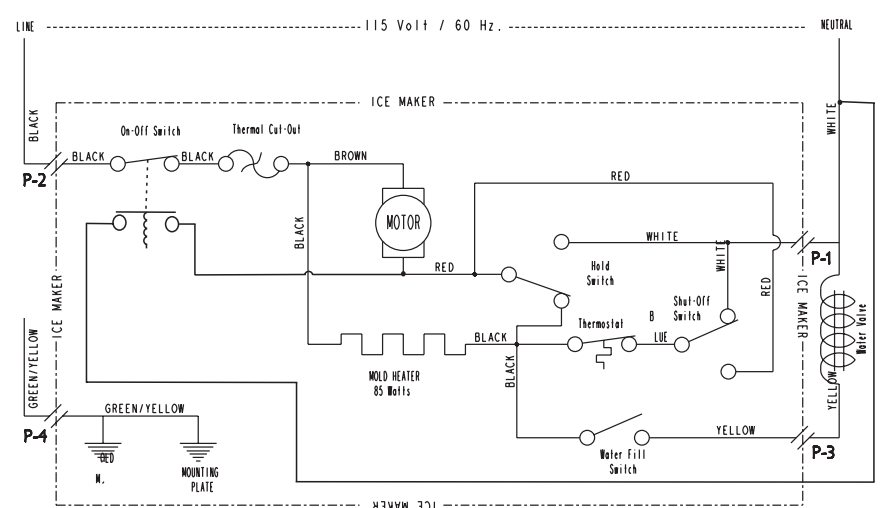
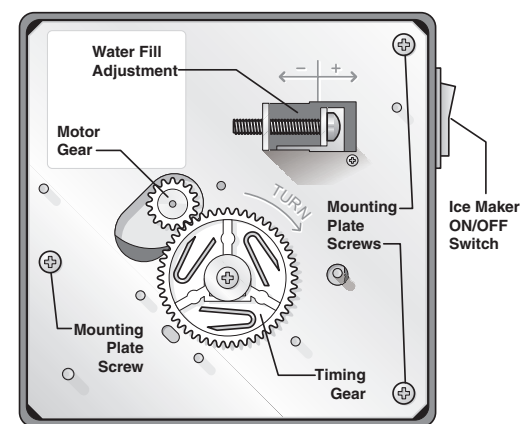

ELECTRONIC DISPENSER

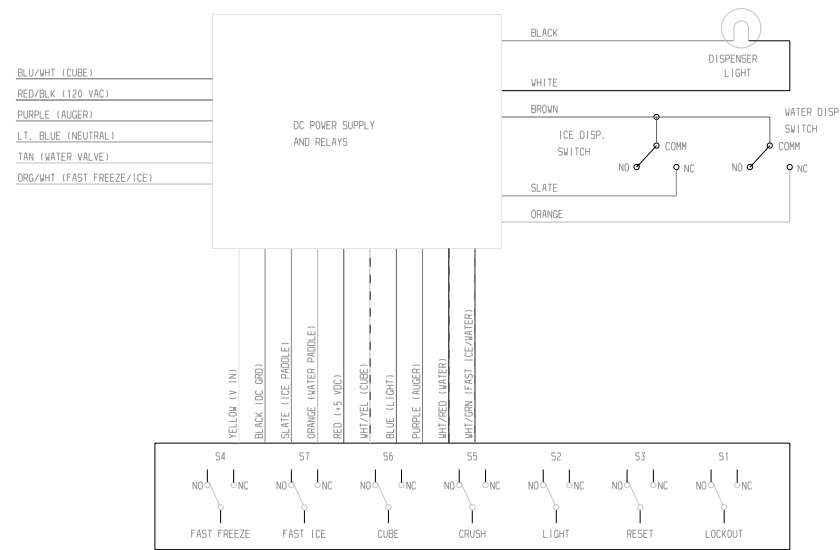

ELECTRO-MECHANICAL DISPENSER

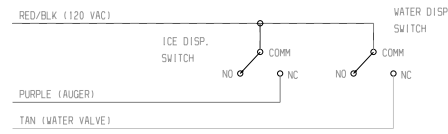

P. T. C. STARTER WITH RUN CAPACITOR

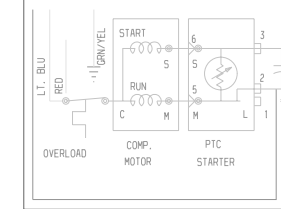

* CAPACITOR IS ONLY USED WITH SOME P.T.C. MODELS.

SERVICE PARTS	23 CUBIC FOOT		26 CUBIC FOOT	
	STANDARD	E-STAR	STANDARD	E-STAR
Compressor Kit *	5303918303	5303918299	5303918303	5303918298
Starter/PTC/TSD *	241524604	241527802	241524604	241527801
Run Capacitor *	218909913	218909915	218909913	218909915
Temp. Control-Refr	241507701	241507701	241507701	241507701
Temp. Control-Frzt	450226-07	450226-07	450226-07	450226-07
Timer (if applicable)	N/A	N/A	N/A	N/A
ADC (if applicable)	241508001	241508001	241508001	241508001
Defrost Heater Kit	5303918253	5303918253	5303918253	5303918253
Defrost Thermostat Kit	5303918214	5303918214	5303918214	5303918214
Evaporator Fan Motor	240369701	240369701	240369701	241537301
Condenser Fan Motor	240523601	241538001	240523601	241538001

* Typical compressor kit includes compressor, electrical components, and filter-drier

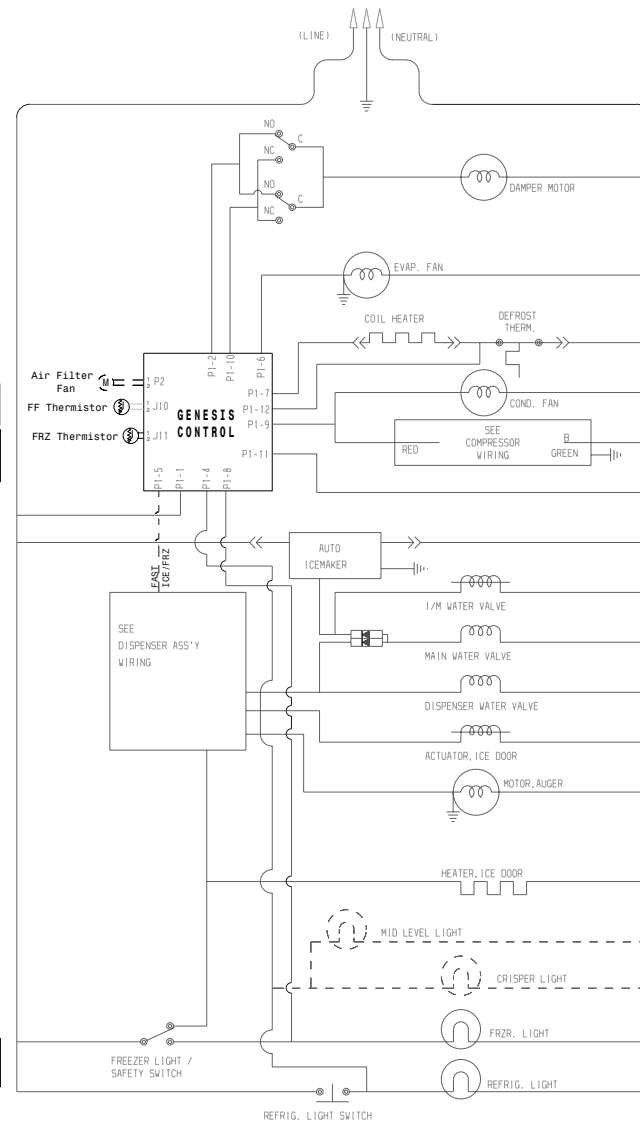
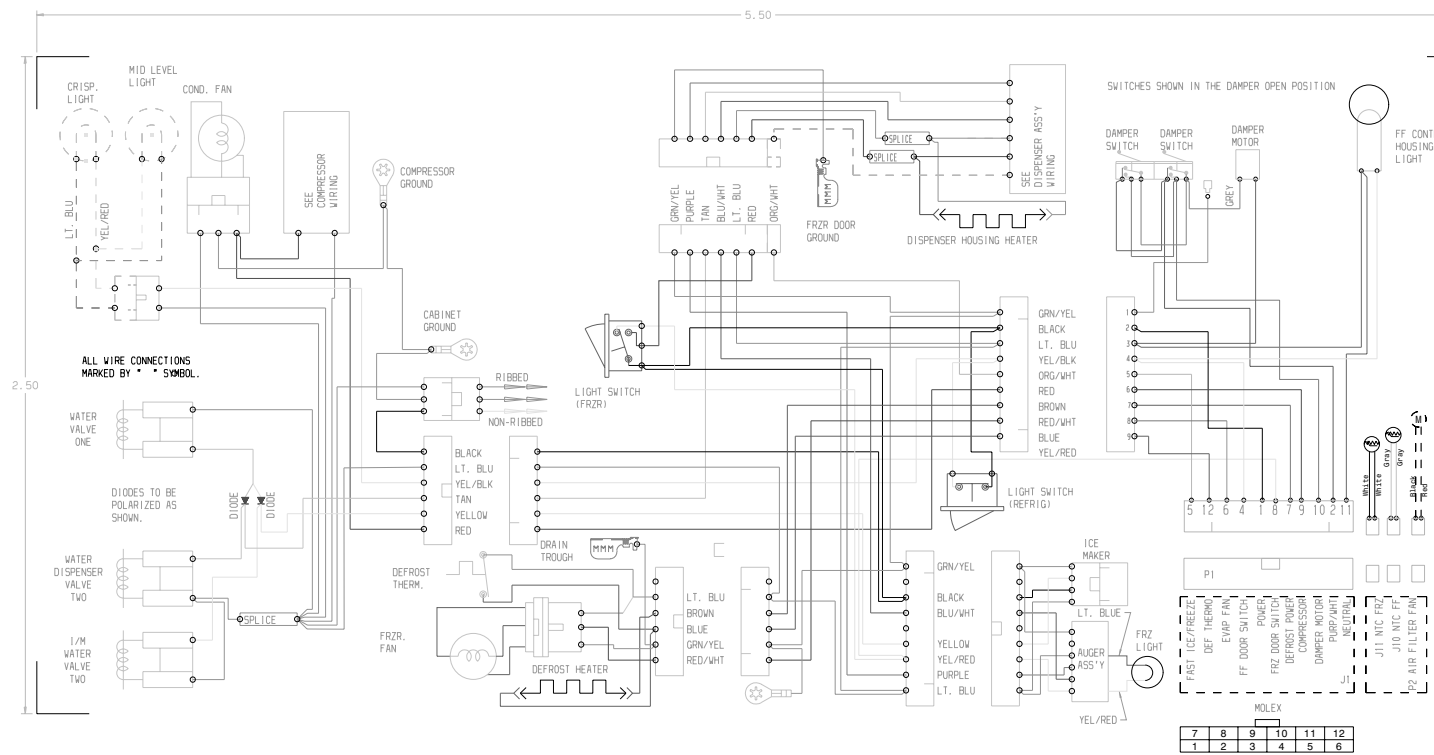

PERFORMANCE DATA NO LOAD AND NO DOOR OPENINGS AT MID-POINT CONTROL SETTING				
Type A With Run/Start Capacitor	65°F (18°C) Ambient	90°F (32°C) Ambient		
Operating Time	32 to 40%	55 to 65%		
Freezer Temperature	0° to 4°F -18° to -16°C	-1° to 3°F -18° to -16°C		
Refrigerator Temperature	34° to 39°F 1° to 4°C	34° to 39°F 1° to 4°C		
Low Side Pressure (cut-in)	5 to 12 psig 34 to 83 kPa	5 to 12 psig 34 to 83 kPa		
Low Side Pressure (cut-out)	-2 to 2 psig -14 to 14 kPa	-2 to 2 psig -14 to 14 kPa		
High Side Pressure (Last 1/3 of cycle)	90 to 115 psig 621 to 793 kPa	130 to 155 psig 896 to 1069 kPa		
Wattage (Last 1/3 of cycle)	120 to 150	130 to 160		
Amps (Running)	1.2 to 1.5	1.2 to 1.5		
Base Voltage	115 vac (127 vac max)	115 vac (127 vac max)		
DEFROST SPECIFICATIONS				
Cabinet Size	Thermostat		Heater	
	Cut-in	Cut-out	Watts	Ohms
23' & 26'	25°F -4°C	47°F 8°C	450	30
Electronic Timer - (ADC) Defrost 24 minutes every 6 to 72 hours of compressor run time.				
CONDENSER FAN MOTOR				
Watts	RPM	Amps		
7	1100 CW Opposite Shaft	.1 Running		
ICE MAKER SPECIFICATIONS				
Electrical	115 vac (127 vac max)	60 Hertz		
Thermostat	Opens at 48°F (9°C)	Closes at 15°F (-9°C)		
Heater Wattage	165			
ICE MAKER CONNECTOR PLUG CONNECTIONS				
Wire Number	Wire Color	Connects to:		
1	Green/Yellow	Ground		
2	Yellow	Water Valve		
3	Black	Line		
4	Lt. Blue	Neutral		

SERVICE DATA SHEET - 240389621
R134a
ICE & WATER - AUTOMATIC DEFROST
SIDE BY SIDE MODELS

IMPORTANT SAFETY NOTE
The information provided herein is designed to assist qualified repair personnel only. Untrained persons should not attempt to make repairs due to the possibility of electrical shock. Disconnect power cord before servicing this appliance.
IMPORTANT
If any green grounding wires are removed during servicing, they must be returned to their original position and properly secured.

CAUTION
All electrical parts and wiring must be shielded from torch flame. DO NOT allow torch to touch insulation; it will char at 200°F and flash ignite (burn) at 500°F. Excessive heat will distort the plastic liner.

NOTE
This product comes equipped with an Electronic Defrost Control. To initiate defrost, depress the fresh food light switch 5 times in 6 seconds (light bulb must be working). To terminate defrost, depress the fresh food light switch 5 times in 6 seconds.

ICE MAKER INFORMATION

Test Cycling

Press the momentary contact on the ON/OFF switch for approximately 15 seconds. Ice maker will continue to complete the cycle.

Water Fill Volume

Remove cover by inserting screwdriver in notch at bottom and prying cover from housing. The water fill adjustment screw will change the fill time. One turn is equal to 20cc (.68 oz.). The correct fill is 102 to 110cc (3.25 to 3.5 oz.). When a water valve is replaced, the fill volume must be checked

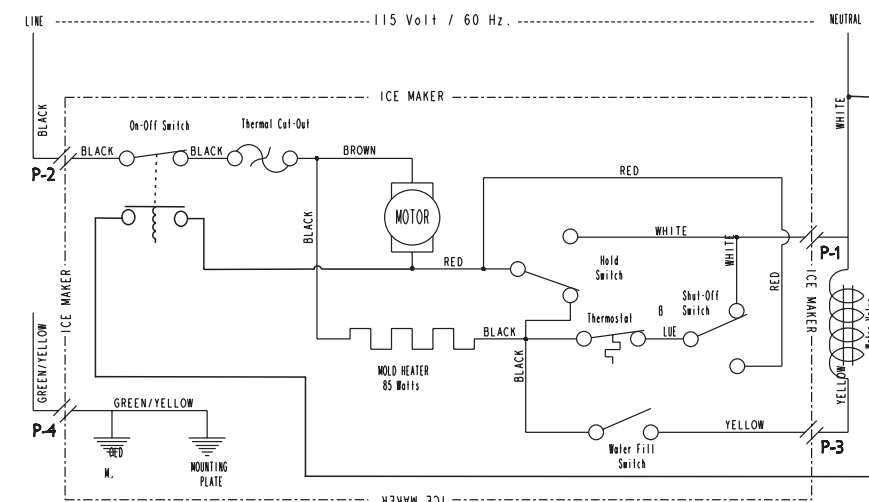
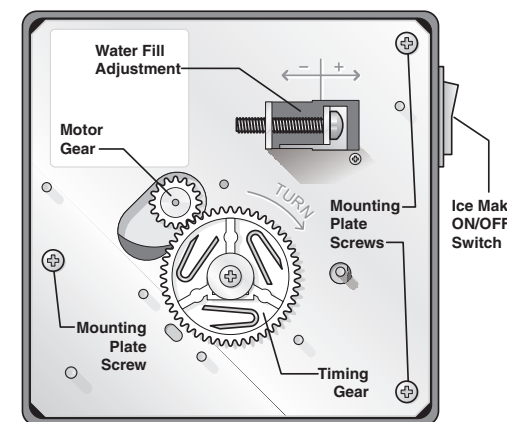

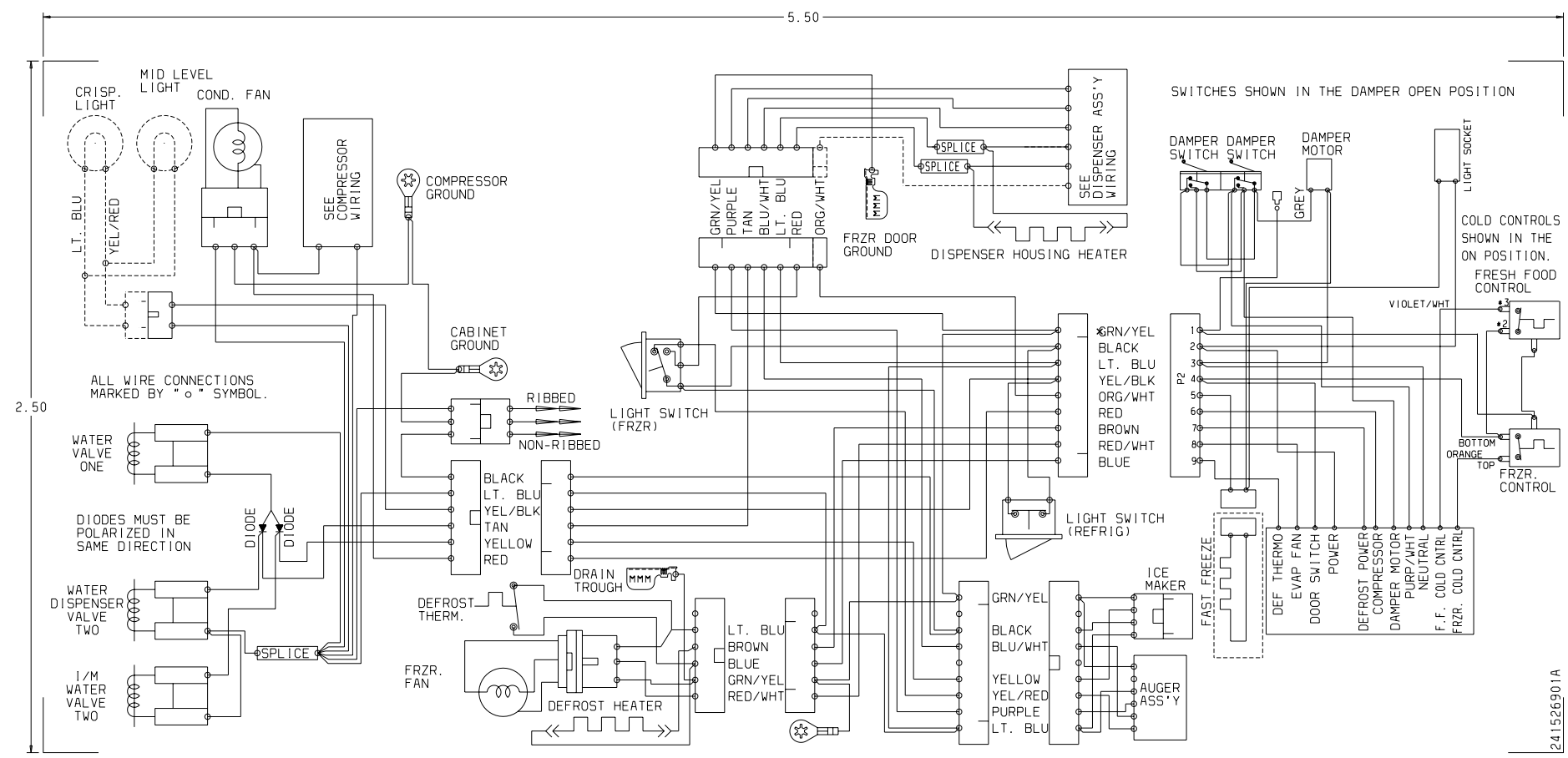

241526901A

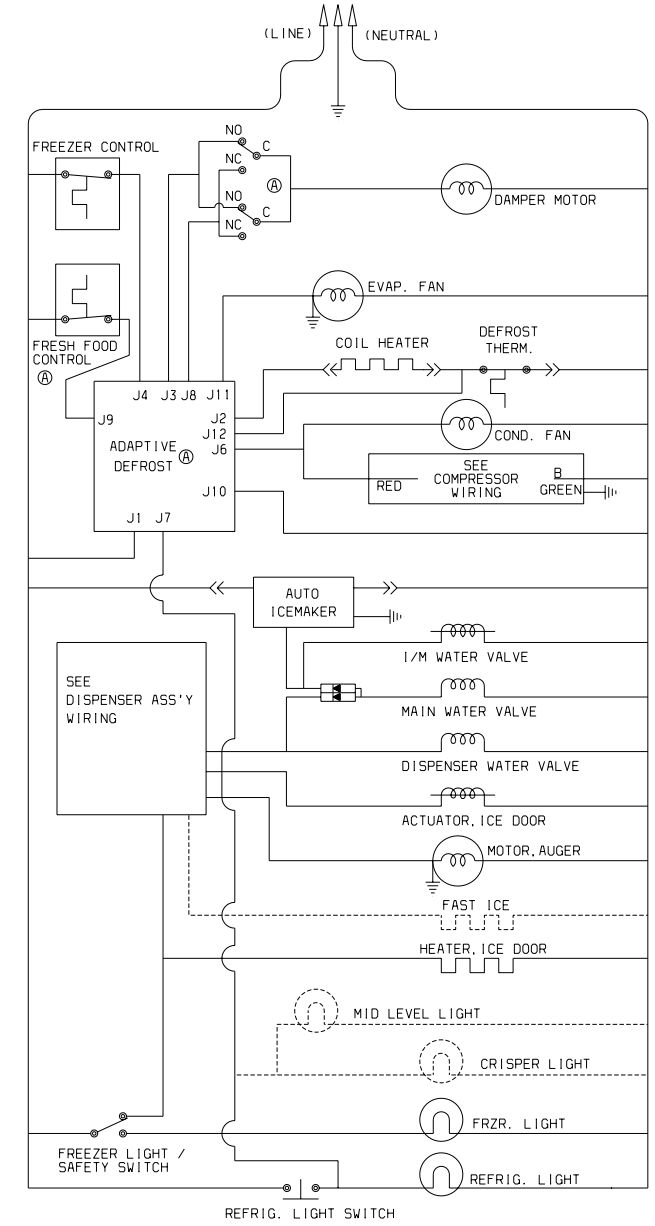

ELECTRONIC DISPENSER

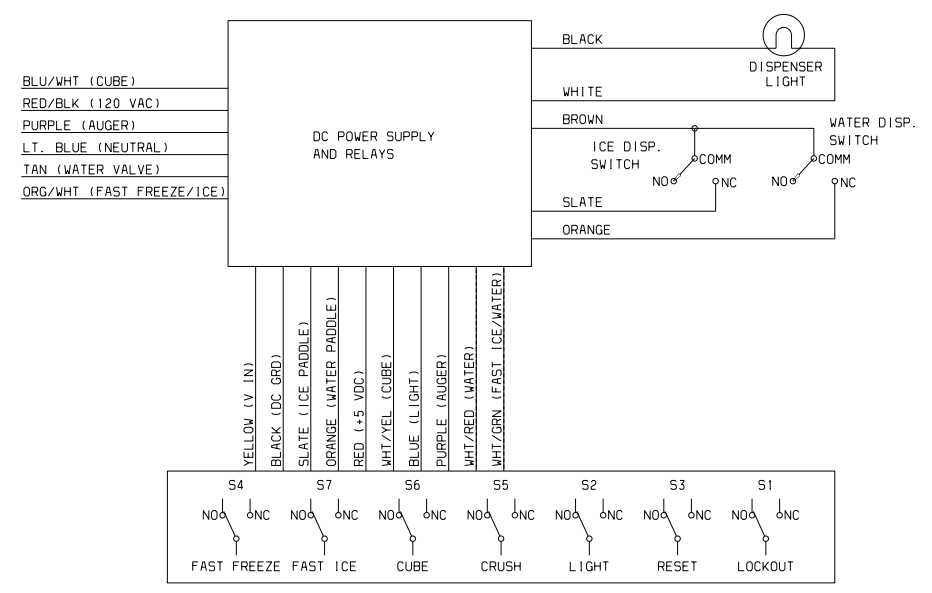

ELECTRO-MECHANICAL DISPENSER

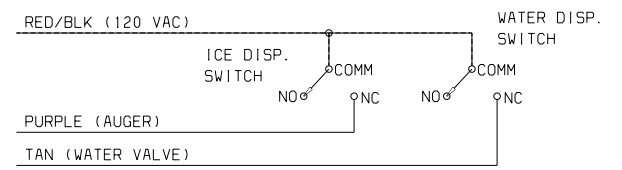

P. T. C. STARTER WITH RUN CAPACITOR

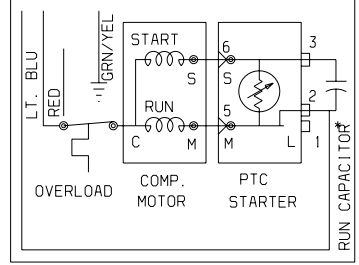

* CAPACITOR IS ONLY USED WITH SOME P. T. C. MODELS.

SERVICE PARTS	23 CUBIC FOOT		26 CUBIC FOOT	
	STANDARD	E-STAR	STANDARD	E-STAR
Compressor Kit *	5303918303	5303918299	5303918303	5303918298
Starter/PTC/TSD *	241524604	241527802	241524604	241527801
Run Capacitor *	218909913	218909915	218909913	218909915
Temp. Control-Refr	241507701	241507701	241507701	241507701
Temp. Control-FrZR	450226-07	450226-07	450226-07	450226-07
Timer (if applicable)	N/A	N/A	N/A	N/A
ADC (if applicable)	241508001	241508001	241508001	241508001
Defrost Heater Kit	5303918253	5303918253	5303918253	5303918253
Defrost Thermostat Kit	5303918214	5303918214	5303918214	5303918214
Evaporator Fan Motor	240369701	240369701	240369701	241537301
Condenser Fan Motor	240523601	241538001	240523601	241538001

* Typical compressor kit includes compressor, electrical components, and filter-drier

PERFORMANCE DATA NO LOAD AND NO DOOR OPENINGS AT MID-POINT CONTROL SETTING				
Type A With Run/Start Capacitor	65°F (18°C) Ambient	90°F (32°C) Ambient		
Operating Time	32 to 40%	55 to 65%		
Freezer Temperature	0° to 4°F -18° to -16°C	-1° to 3°F -18° to -16°C		
Refrigerator Temperature	34° to 39°F 1° to 4°C	34° to 39°F 1° to 4°C		
Low Side Pressure (cut-in)	5 to 12 psig 34 to 83 kPa	5 to 12 psig 34 to 83 kPa		
Low Side Pressure (cut-out)	-2 to 2 psig -14 to 14 kPa	-2 to 2 psig -14 to 14 kPa		
High Side Pressure (Last 1/3 of cycle)	90 to 115 psig 621 to 793 kPa	130 to 155 psig 896 to 1069 kPa		
Wattage (Last 1/3 of cycle)	120 to 150	130 to 160		
Amps (Running)	1.2 to 1.5	1.2 to 1.5		
Base Voltage	115 vac (127 vac max)	115 vac (127 vac max)		
DEFROST SPECIFICATIONS				
Cabinet Size	Thermostat		Heater	
	Cut-in	Cut-out	Watts	Ohms
23' & 26'	25°F -4°C	47°F 8°C	450	30
Electronic Timer - (ADC) Defrost 24 minutes every 6 to 72 hours of compressor run time.				
CONDENSER FAN MOTOR				
Watts	RPM	Amps		
7	1100 CW Opposite Shaft	.1 Running		
ICE MAKER SPECIFICATIONS				
Electrical	115 vac (127 vac max)	60 Hertz		
Thermostat	Opens at 48°F (9°C)	Closes at 15°F (-9°C)		
Heater Wattage	165			
ICE MAKER CONNECTOR PLUG CONNECTIONS				
Wire Number	Wire Color	Connects to:		
1	Green/Yellow	Ground		
2	Yellow	Water Valve		
3	Black	Line		
4	Lt. Blue	Neutral		

SERVICE DATA SHEET - 240389622
R134a
ICE & WATER - AUTOMATIC DEFROST
SIDE BY SIDE MODELS

IMPORTANT SAFETY NOTE

The information provided herein is designed to assist qualified repair personnel only. Untrained persons should not attempt to make repairs due to the possibility of electrical shock. Disconnect power cord before servicing this appliance.

IMPORTANT

If any green grounding wires are removed during servicing, they must be returned to their original position and properly secured.

CAUTION

All electrical parts and wiring must be shielded from torch flame. DO NOT allow torch to touch insulation; it will char at 200°F and flash ignite (burn) at 500°F. Excessive heat will distort the plastic liner.

NOTE

This product comes equipped with an Electronic Defrost Control. To initiate defrost, depress the fresh food light switch 5 times in 6 seconds (light bulb must be working). To terminate defrost, depress the fresh food light switch 5 times in 6 seconds.

ICE MAKER INFORMATION LEFT SIDE MOUNTED

Test Cycling

Remove cover by inserting screwdriver in notch at bottom and prying cover from housing. Use screwdriver to rotate motor gear counterclockwise until holding switch circuit is completed. All components of ice maker should function to complete the cycle.

Water Fill Volume

The water fill adjustment screw will change the fill time. One full turn is equal to 20cc (.68 oz.). The correct fill is 102 to 130cc (3.4 to 4.3 oz.). When a water valve is replaced, the fill volume must be checked.

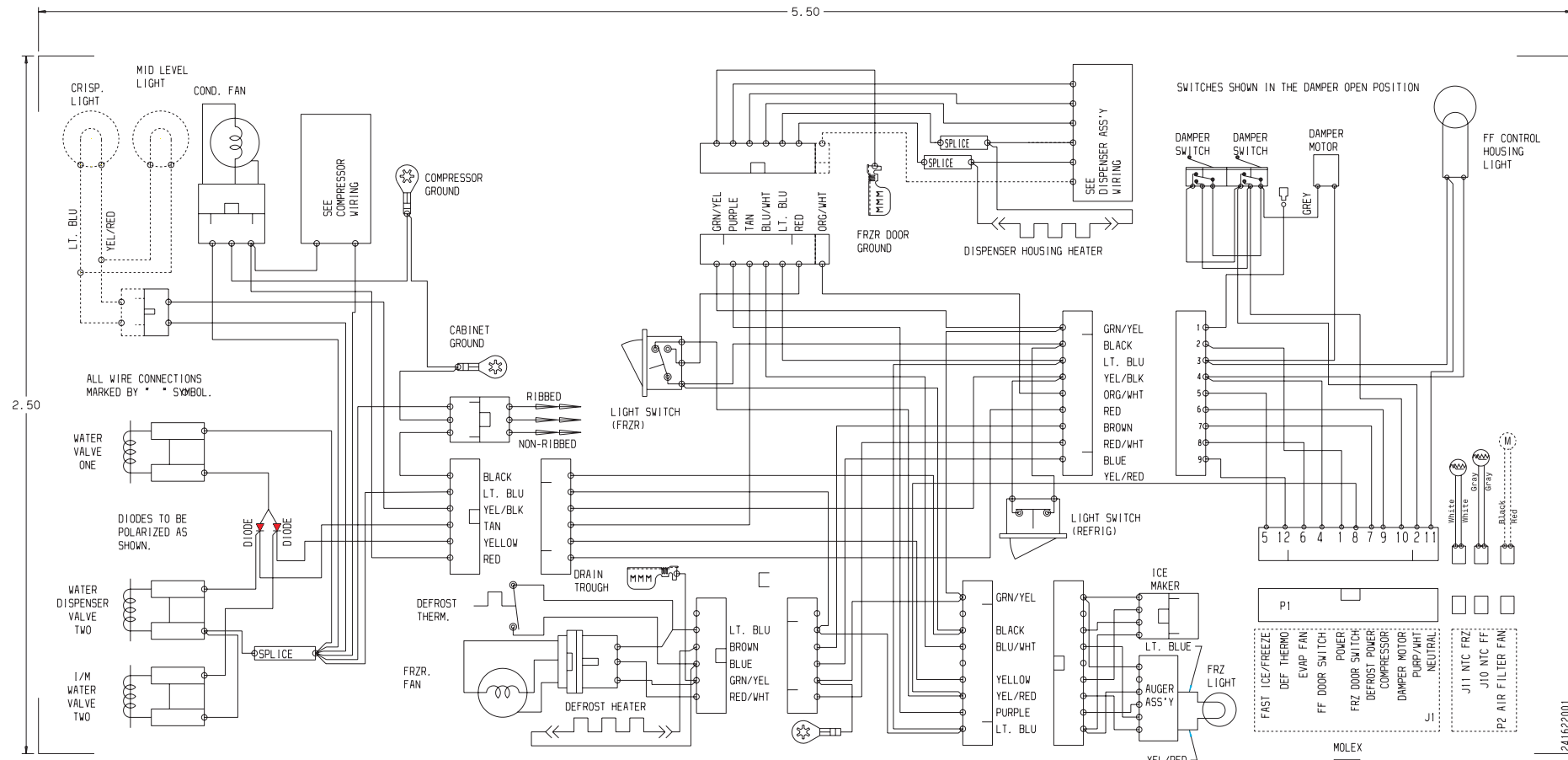

ELECTRONIC DISPENSER

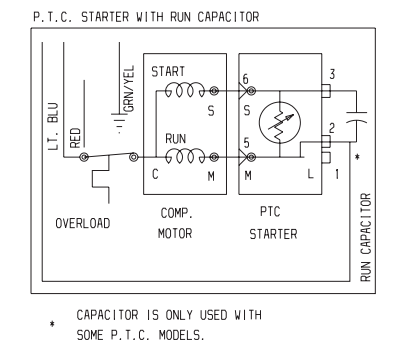
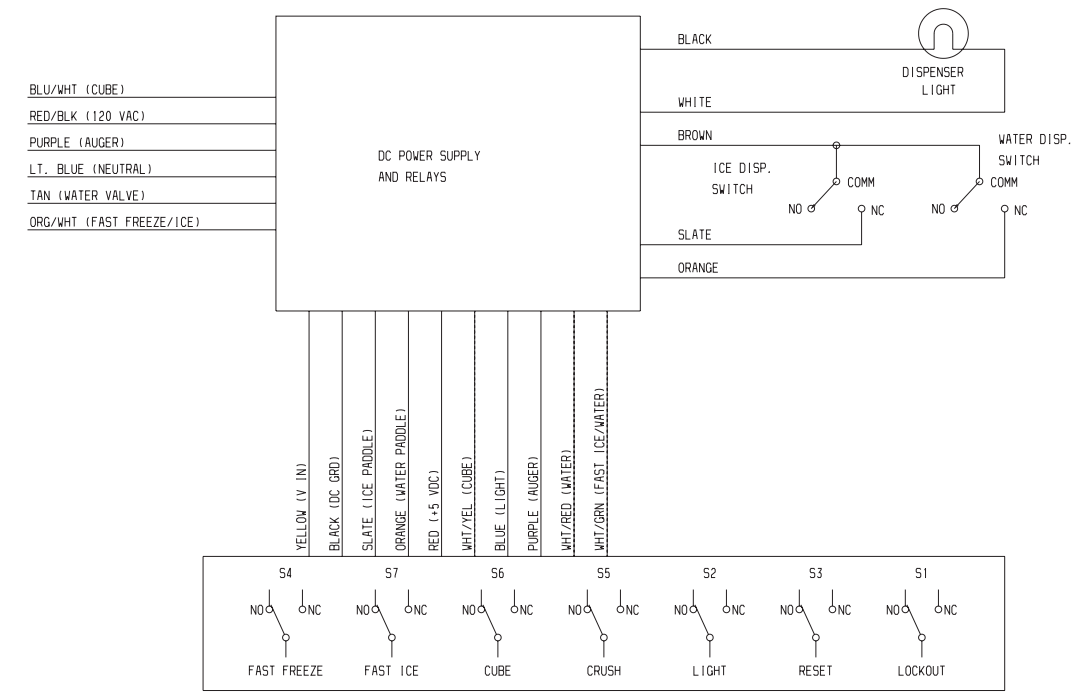

ELECTRO-MECHANICAL DISPENSER

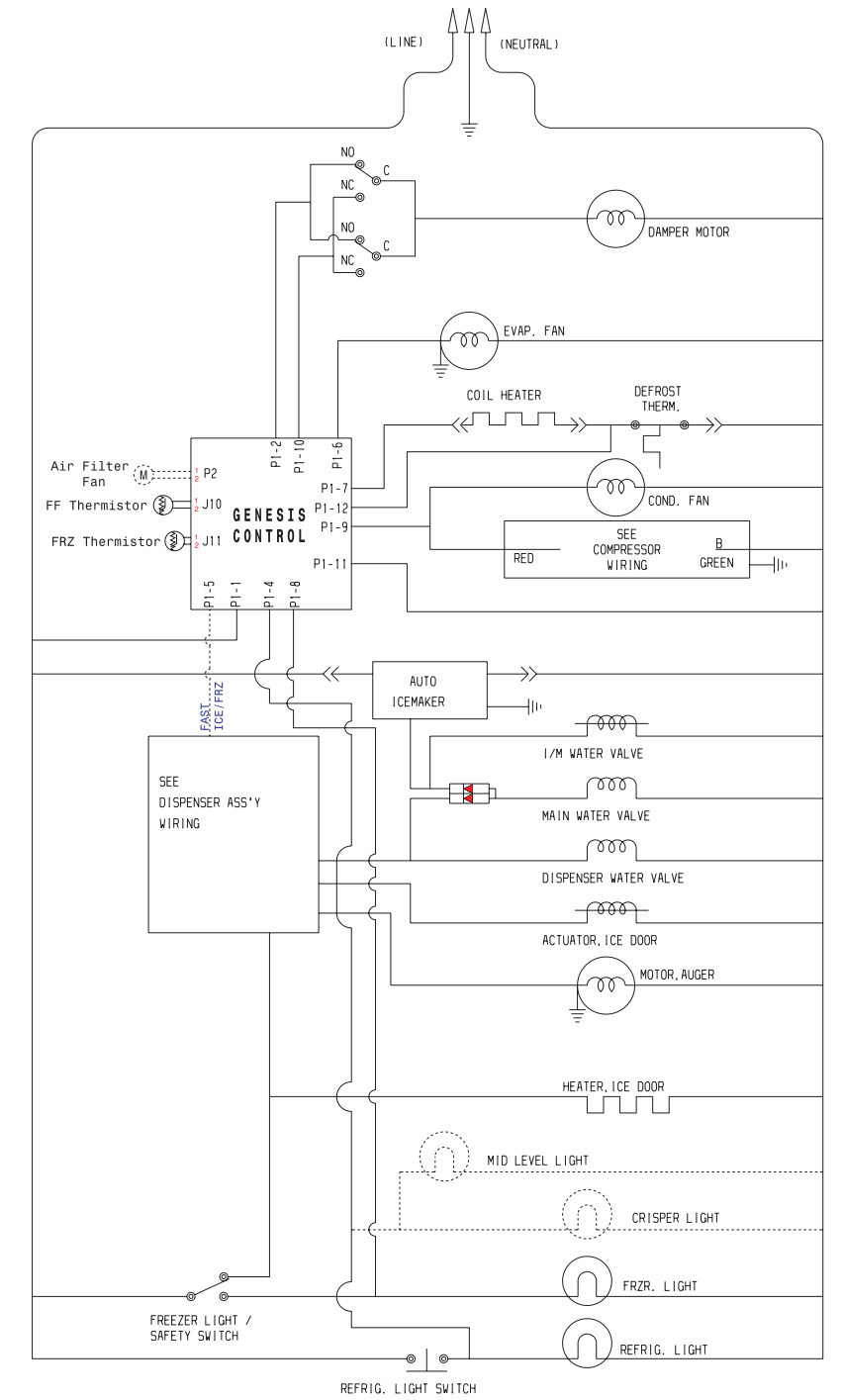
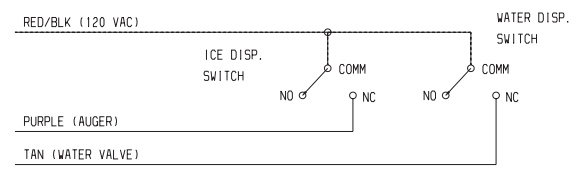

PRINTED IN USA

PERFORMANCE DATA
NO LOAD AND NO DOOR OPENINGS AT MID-POINT CONTROL SETTING

Type A With Run/Start Capacitor	65°F (18°C) Ambient	90°F (32°C) Ambient
Operating Time	32 to 40%	55 to 65%
Freezer Temperature	0° to 4°F -18° to -16°C	-1° to 3°F -18° to -16°C
Refrigerator Temperature	34° to 39°F 1° to 4°C	34° to 39°F 1° to 4°C
Low Side Pressure (cut-in)	5 to 12 psig 34 to 83 kPa	5 to 12 psig 34 to 83 kPa
Low Side Pressure (cut-out)	-2 to 2 psig -14 to 14 kPa	-2 to 2 psig -14 to 14 kPa
High Side Pressure (Last 1/3 of cycle)	90 to 115 psig 621 to 793 kPa	130 to 155 psig 896 to 1069 kPa
Wattage (Last 1/3 of cycle)	120 to 150	130 to 160
Amps (Running)	1.2 to 1.5	1.2 to 1.5
Base Voltage	115 vac (127 vac max)	115 vac (127 vac max)

DEFROST SPECIFICATIONS

Cabinet Size	Thermostat		Heater	
	Cut-in	Cut-out	Watts	Ohms
23' & 26'	25°F -4°C	47°F 8°C	450	30

Electronic Timer - (ADC) Defrost 24 minutes every 6 to 72 hours of compressor run time.

CONDENSER FAN MOTOR

Watts	RPM	Amps
7	1100 CW Opposite Shaft	.1 Running

ICE MAKER SPECIFICATIONS

Electrical	115 vac (127 vac max)	60 Hertz
Thermostat	Opens at 48°F (9°C)	Closes at 15°F (-9°C)
Heater Wattage	165	

ICE MAKER CONNECTOR PLUG CONNECTIONS

Wire Number	Wire Color	Connects to:
1	Green/Yellow	Ground
2	Yellow	Water Valve
3	Black	Line
4	Lt. Blue	Neutral

SERVICE DATA SHEET - 240389623

R134a
ICE & WATER - AUTOMATIC DEFROST
SIDE BY SIDE MODELS

IMPORTANT SAFETY NOTE

The information provided herein is designed to assist qualified repair personnel only. Untrained persons should not attempt to make repairs due to the possibility of electrical shock. Disconnect power cord before servicing this appliance.

IMPORTANT

If any green grounding wires are removed during servicing, they must be returned to their original position and properly secured.

CAUTION

All electrical parts and wiring must be shielded from torch flame. DO NOT allow torch to touch insulation; it will char at 200°F and flash ignite (burn) at 500°F. Excessive heat will distort the plastic liner.

NOTE

This product comes equipped with an Electronic Defrost Control. To initiate defrost, depress the fresh food light switch 5 times in 6 seconds (light bulb must be working). To terminate defrost, depress the fresh food light switch 5 times in 6 seconds.

ICE MAKER INFORMATION

Test Cycling

Press the momentary contact on the ON/OFF switch for approximately 15 seconds. Ice maker will continue to complete the cycle.

Water Fill Volume

Remove cover by inserting screwdriver in notch at bottom and prying cover from housing. The water fill adjustment screw will change the fill time. One turn is equal to 20cc (.68 oz.). The correct fill is 102 to 110cc (3.25 to 3.5 oz.). When a water valve is replaced, the fill volume must be checked

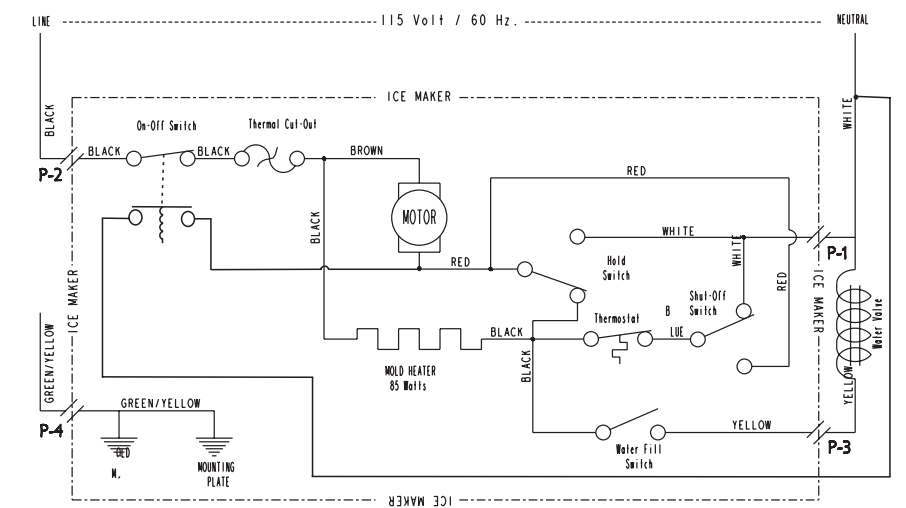
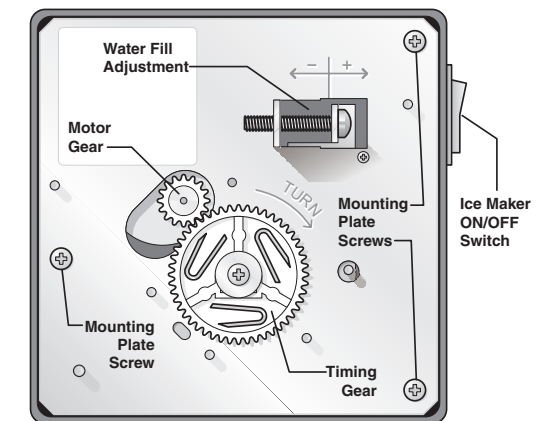

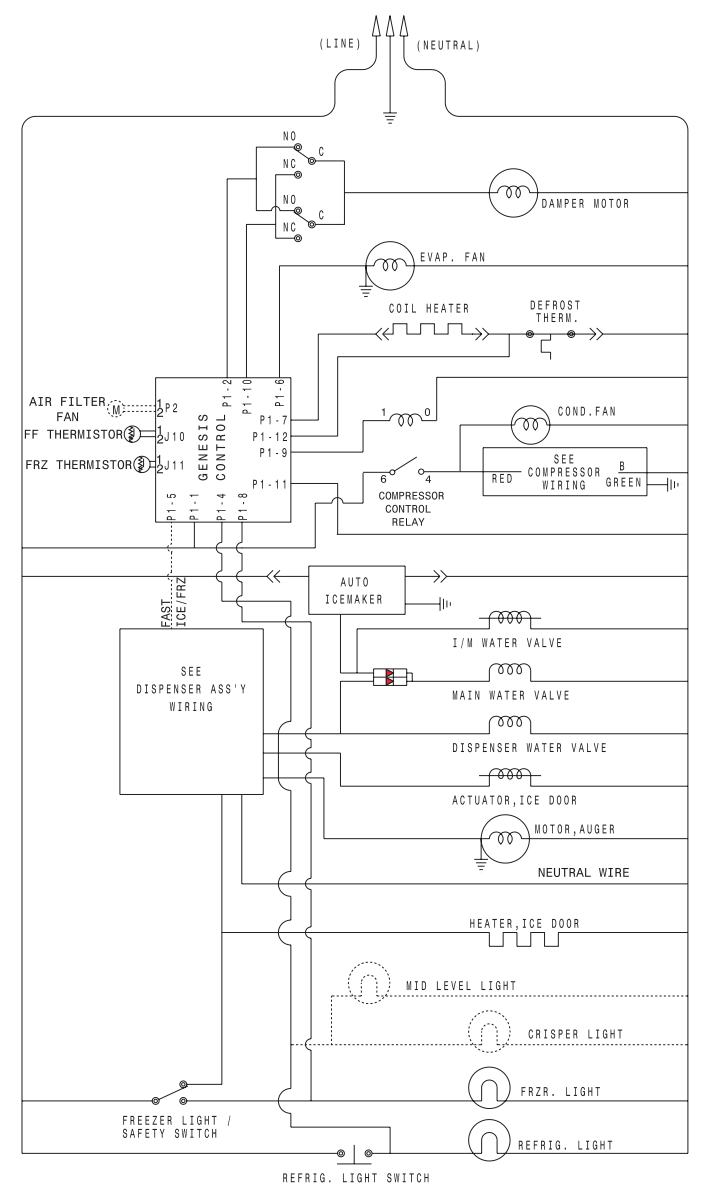
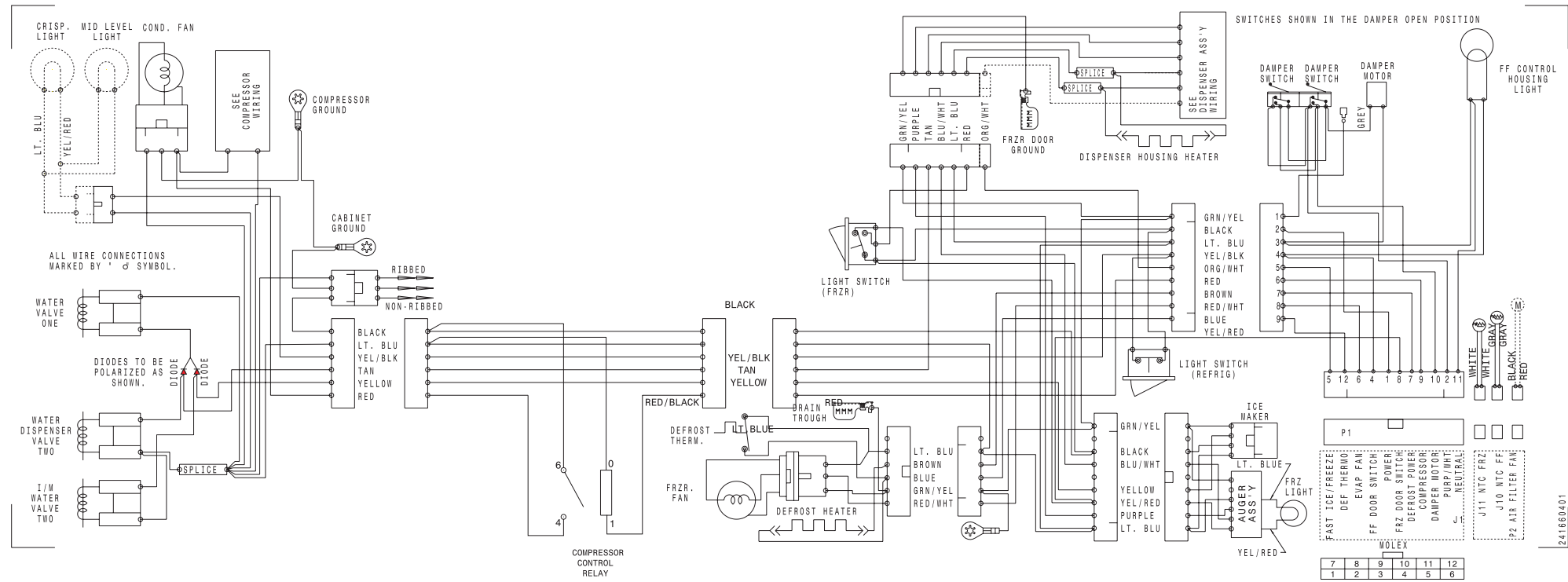

ELECTRONIC DISPENSER

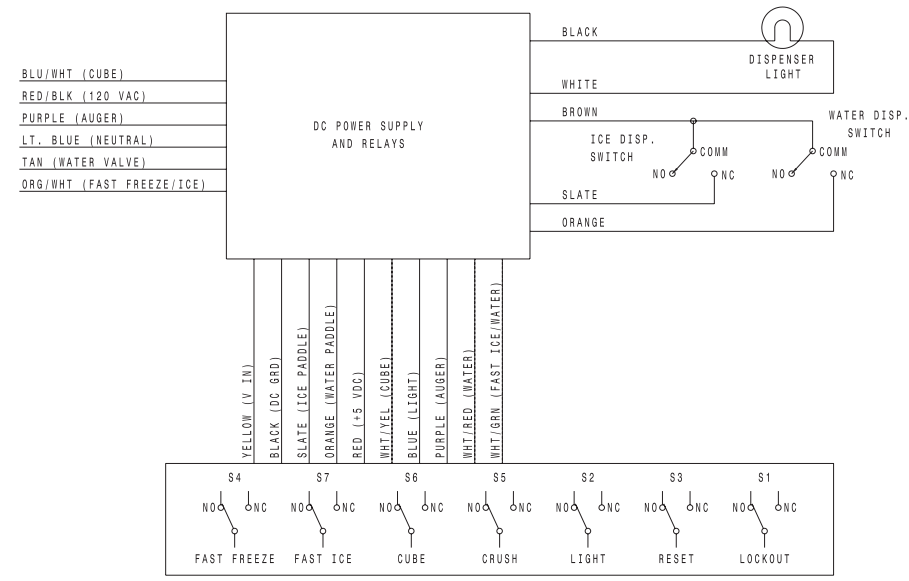

ELECTRO-MECHANICAL DISPENSER

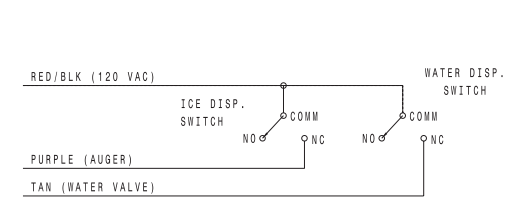

P.T.C. STARTER WITH RUN CAPACITOR

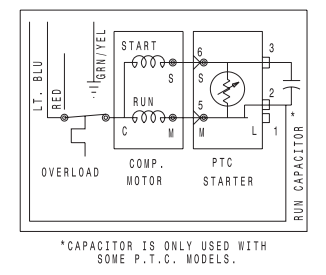

PERFORMANCE DATA NO LOAD AND NO DOOR OPENINGS AT MID-POINT CONTROL SETTING				
Type A With Run/Start Capacitor	65°F (18°C) Ambient	90°F (32°C) Ambient		
Operating Time	32 to 40%	55 to 65%		
Freezer Temperature	0° to 4°F -18° to -16°C	-1° to 3°F -18° to -16°C		
Refrigerator Temperature	34° to 39°F 1° to 4°C	34° to 39°F 1° to 4°C		
Low Side Pressure (cut-in)	5 to 12 psig 34 to 83 kPa	5 to 12 psig 34 to 83 kPa		
Low Side Pressure (cut-out)	-2 to 2 psig -14 to 14 kPa	-2 to 2 psig -14 to 14 kPa		
High Side Pressure (Last 1/3 of cycle)	90 to 115 psig 621 to 793 kPa	130 to 155 psig 896 to 1069 kPa		
Wattage (Last 1/3 of cycle)	120 to 150	130 to 160		
Amps (Running)	1.2 to 1.5	1.2 to 1.5		
Base Voltage	115 vac (127 vac max)	115 vac (127 vac max)		
DEFROST SPECIFICATIONS				
Cabinet Size	Thermostat		Heater	
	Cut-in	Cut-out	Watts	Ohms
23' & 26'	25°F -4°C	47°F 8°C	450	30
Electronic Timer - (ADC) Defrost 24 minutes every 6 to 72 hours of compressor run time.				
CONDENSER FAN MOTOR				
Watts	RPM	Amps		
7	1100 CW Opposite Shaft	.1 Running		
ICE MAKER SPECIFICATIONS				
Electrical	115 vac (127 vac max)	60 Hertz		
Thermostat	Opens at 48°F (9°C)	Closes at 15°F (-9°C)		
Heater Wattage	165			
ICE MAKER CONNECTOR PLUG CONNECTIONS				
Wire Number	Wire Color	Connects to:		
1	Green/Yellow	Ground		
2	Yellow	Water Valve		
3	Black	Line		
4	Lt. Blue	Neutral		

SERVICE DATA SHEET - 240389624
R134a
ICE & WATER - AUTOMATIC DEFROST
SIDE BY SIDE MODELS

IMPORTANT SAFETY NOTE

The information provided herein is designed to assist qualified repair personnel only. Untrained persons should not attempt to make repairs due to the possibility of electrical shock. Disconnect power cord before servicing this appliance.

IMPORTANT

If any green grounding wires are removed during servicing, they must be returned to their original position and properly secured.

CAUTION

All electrical parts and wiring must be shielded from torch flame. DO NOT allow torch to touch insulation; it will char at 200°F and flash ignite (burn) at 500°F. Excessive heat will distort the plastic liner.

NOTE

This product comes equipped with an Electronic Defrost Control. To initiate defrost, depress the fresh food light switch 5 times in 6 seconds (light bulb must be working). To terminate defrost, depress the fresh food light switch 5 times in 6 seconds.

ICE MAKER INFORMATION
LEFT SIDE MOUNTED
Test Cycling

Remove cover by inserting screwdriver in notch at bottom and prying cover from housing. Use screwdriver to rotate motor gear counterclockwise until holding switch circuit is completed. All components of ice maker should function to complete the cycle.

Water Fill Volume

The water fill adjustment screw will change the fill time. One full turn is equal to 20cc (.68 oz.). The correct fill is 102 to 130cc (3.4 to 4.3 oz.). When a water valve is replaced, the fill volume must be checked.

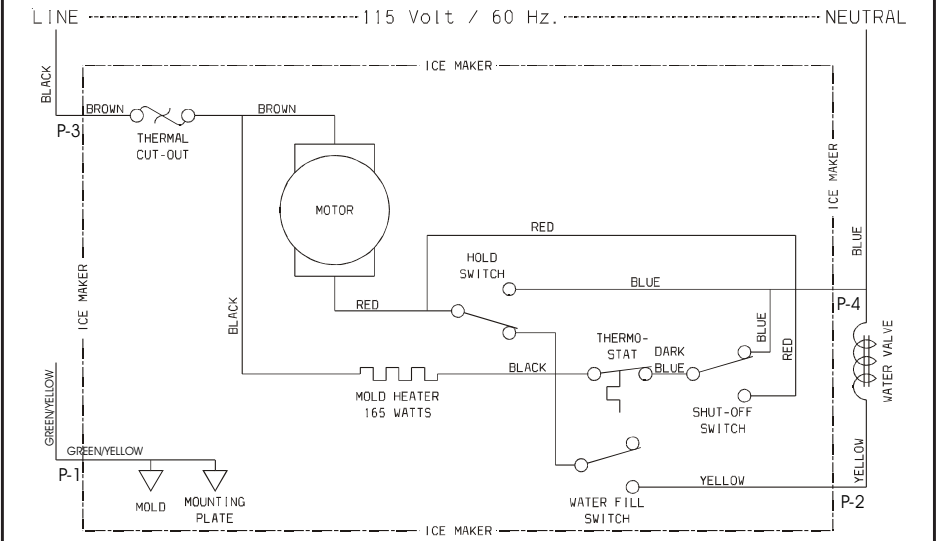
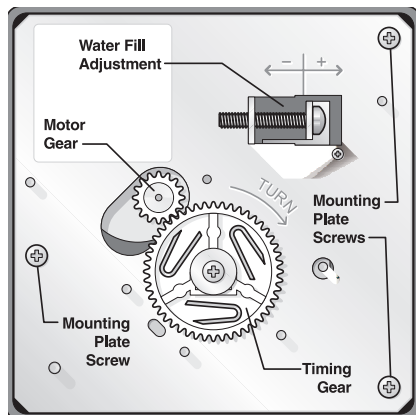

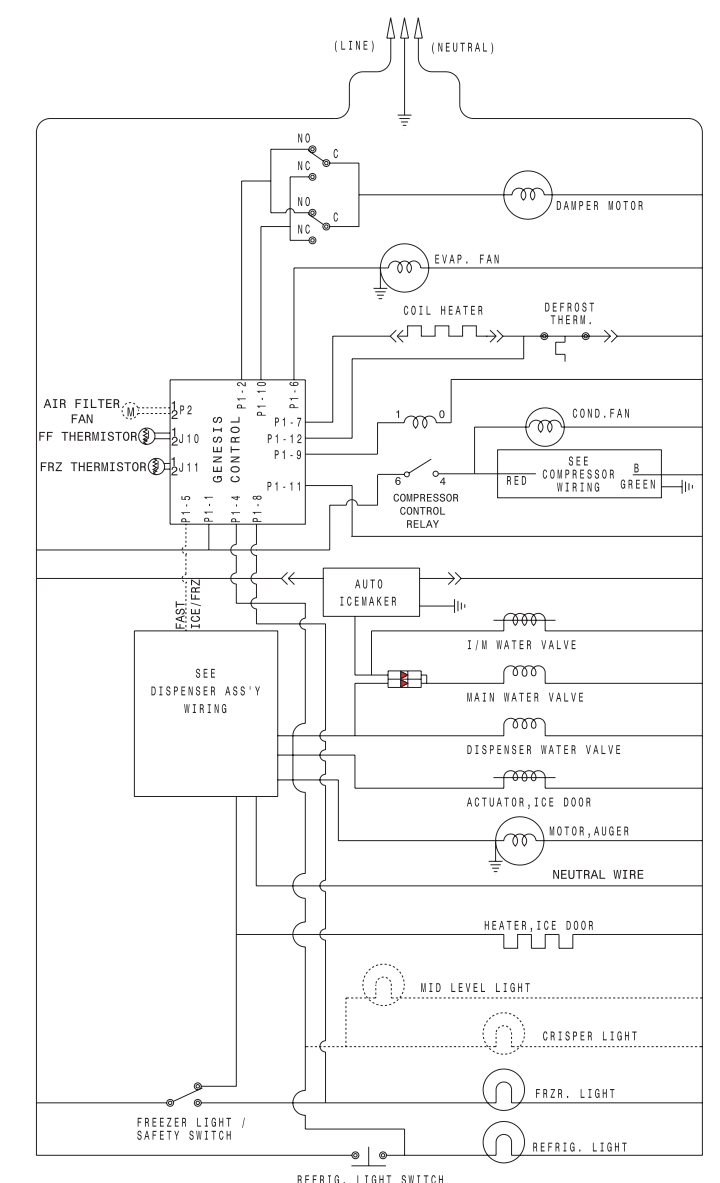
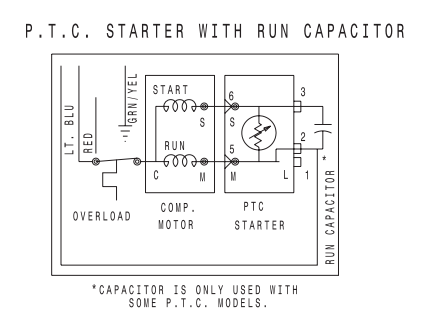
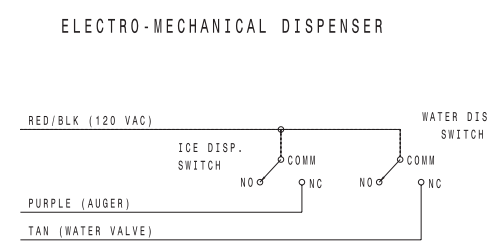
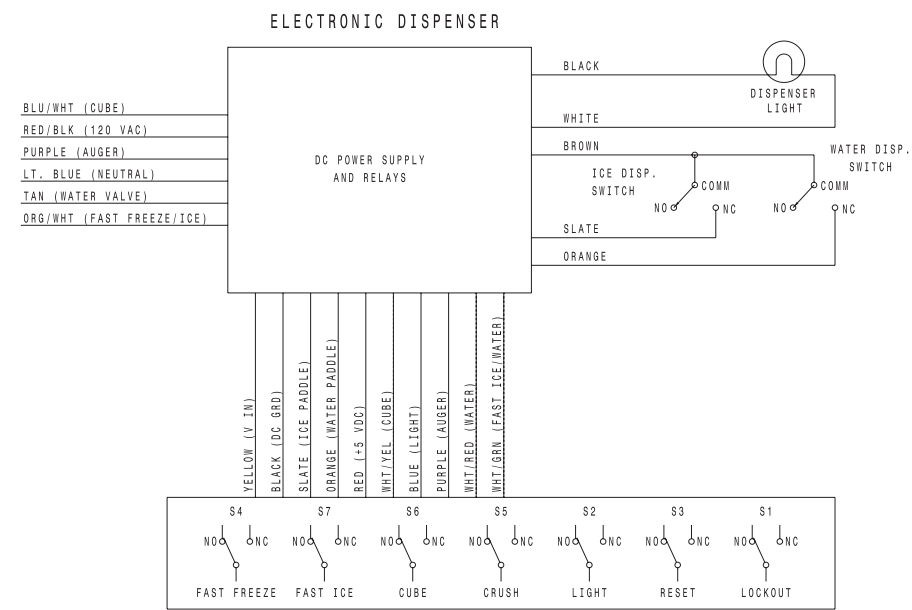
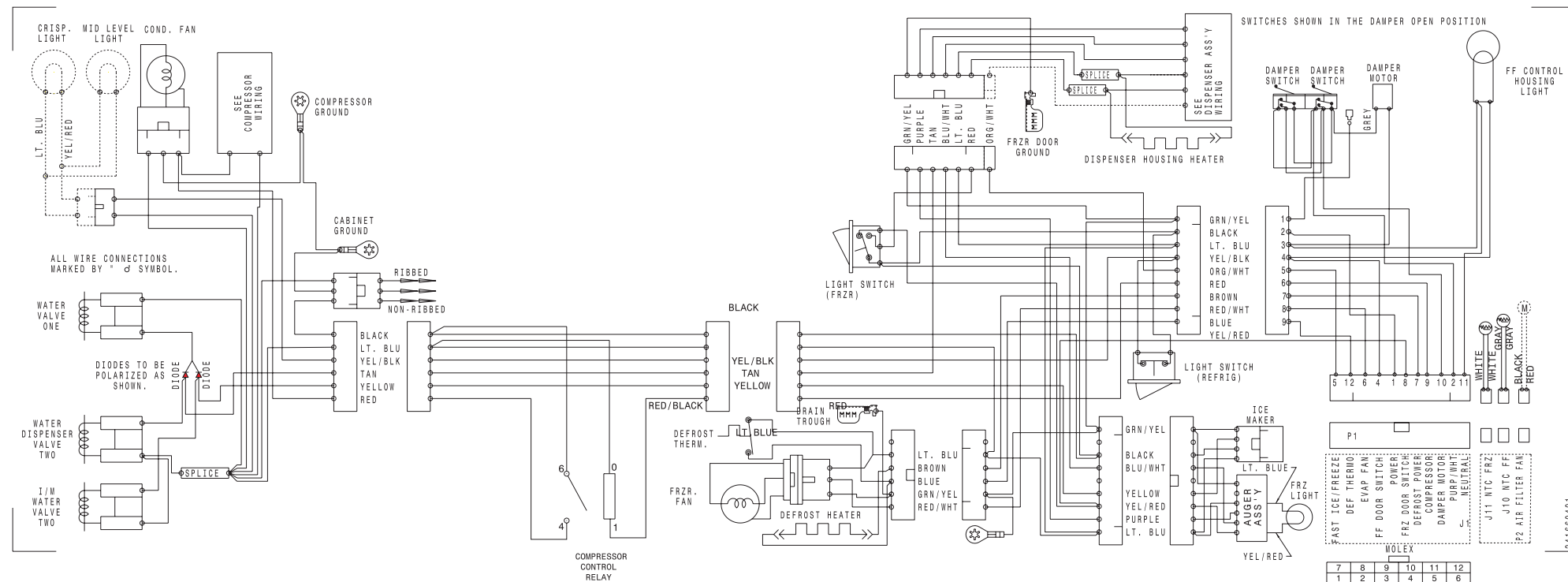



PERFORMANCE DATA NO LOAD AND NO DOOR OPENINGS AT MID-POINT CONTROL SETTING				
Type A with Run/Start Capacitor	65°F (18°C) Ambient		90°F (32°C) Ambient	
	Variable Speed	Standard	Variable Speed	Standard
Operating Time	74 to 84%	32 to 40%	100%	55 to 65%
Freezer Temperature	-2° to 2°F -19° to -17°C	0° to 4°F -18° to -16°C	-1° to 3°F -18° to -16°C	-1° to 3°F -18° to -16°C
Refrigerator Temperature	34° to 39°F 1° to 4°C	34° to 39°F 1° to 4°C	34° to 39°F 1° to 4°C	34° to 39°F 1° to 4°C
Low Side Pressure (cut-in)	5 to 12 psig 43 to 83 kPa	5 to 12 psig 43 to 83 kPa	N/A	5 to 12 psig 43 to 83 kPa
Low Side Pressure (cut-out)	-2 to 2 psig -14 to 14kPa	-2 to 2 psig -14 to 14kPa	-2 to 2 psig -14 to 14kPa	-2 to 2 psig -14 to 14kPa
High Side Pressure (last 1/3 cycle)	90 to 105 psig 621 to 724 kPa	90 to 115 psig 621 to 793 kPa	120 to 135 psig 827 to 931 kPa	130 to 155 psig 896 to 1069 kPa
Wattage (last 1/3 cycle)	60 to 65	120 to 150	65 to 80	130 to 160
Amps (running)	.7 to 1.1	1.0 to 1.4	.9 to 1.3	1.1 to 1.5
Base Voltage	115 vac (127 vac max)		115 vac (127 vac max)	
DEFROST SPECIFICATIONS				
Cabinet Size	Thermostat		Heater	
	Cut-in	Cut-out	Watts	Ohms
23"	25°F (-4°C)	47°F (8°C)	450	30
Electronic Timer – (ADC) Defrost 24 minutes every 6 – 96 hours of compressor run time.				
CONDENSER FAN MOTOR				
Watts	RPM		Amps	
2.8	950 CW Opposite Shaft		.1 Running	
ICE MAKER SPECIFICATIONS				
Electrical	115 vac (127 vac max)			
Thermostat	Opens at 48°F (9°C)		Closes at 15°F (-9°C)	
Heater Voltage	85 vac			
ICE MAKER CONNECTOR PLUG CONNECTIONS				
Wire Number	Wire Color	Connects to:		
1	Green/Yellow	Ground		
2	Yellow	Water Valve		
3	Black	Line		
4	Light Blue	Neutral		

IMPORTANT

Please return this sheet to its original location.

SERVICE DATA SHEET

241532603

ICE & WATER - AUTOMATIC DEFROST
COUNTER DEPTH SIDE BY SIDE - R134a

IMPORTANT SAFETY NOTE

The information provided herein is designed to assist qualified repair personnel only. Untrained persons should not attempt to make repairs due to the possibility of electrical shock. Disconnect power cord before servicing this appliance.

IMPORTANT

If any green ground wiring are removed during servicing, they must be returned to their original position and properly secured.

CAUTION

All electrical parts and wiring must be shielded from torch flame. DO NOT allow torch to touch insulation; it will char at 200°F and flash ignite (burn) at 500°F. Excessive heat will distort the plastic liner.

NOTE

This product comes equipped with an Adaptive Defrost Control (ADC). To activate manual defrost, press and hold the Freezer temperature UP (WARMER) key while pressing the Fresh Food temperature DOWN (COLDER) key 5 times within 6 seconds. A "d" in the freezer temperature window and "F" in the refrigerator temperature window will display when the heater is activated. To deactivate manual defrost, press and hold Freezer temperature UP (WARMER) key while pressing the Fresh Food temperature DOWN (COLDER) key 5 times within 6 seconds. "d" and "F" will be displayed until the defrost cycle is complete. (approx. 8 minutes)

ICE MAKER INFORMATION

Test Cycling

Press the momentary contact on the ON/OFF switch for approximately 15 seconds. Ice maker will continue to complete the cycle.

Water Fill Volume

Remove cover by inserting screwdriver in notch at bottom and prying cover from housing. The water fill adjustment screw will change the fill time. One turn is equal to 20cc (.68 oz.). The correct fill is 102 to 110cc (3.25 to 3.5 oz.). When a water valve is replaced, the fill volume must be checked

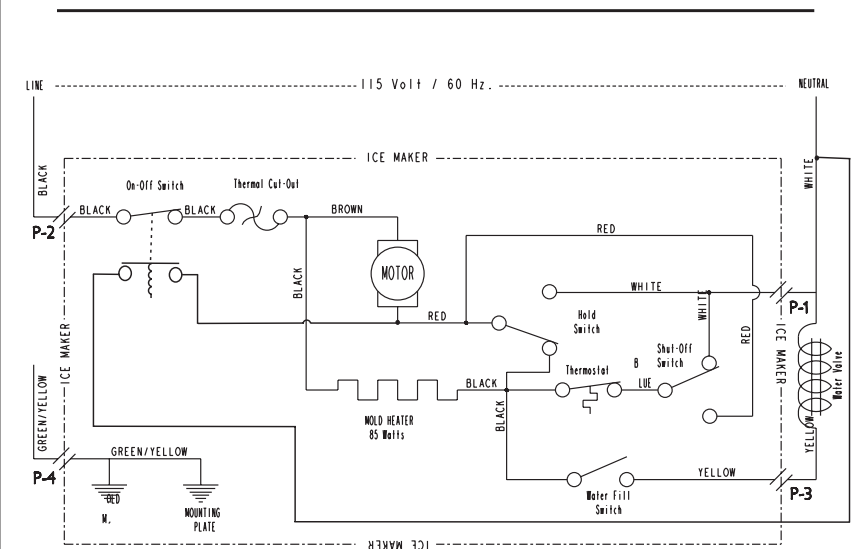
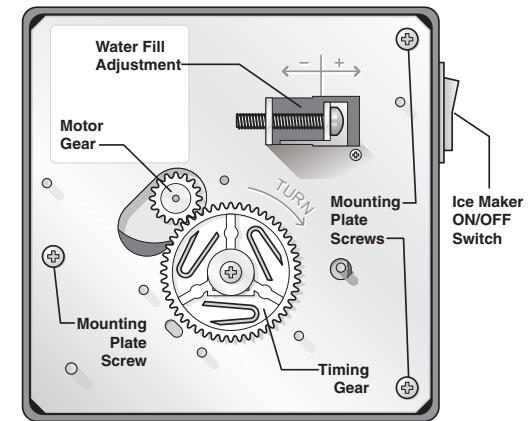

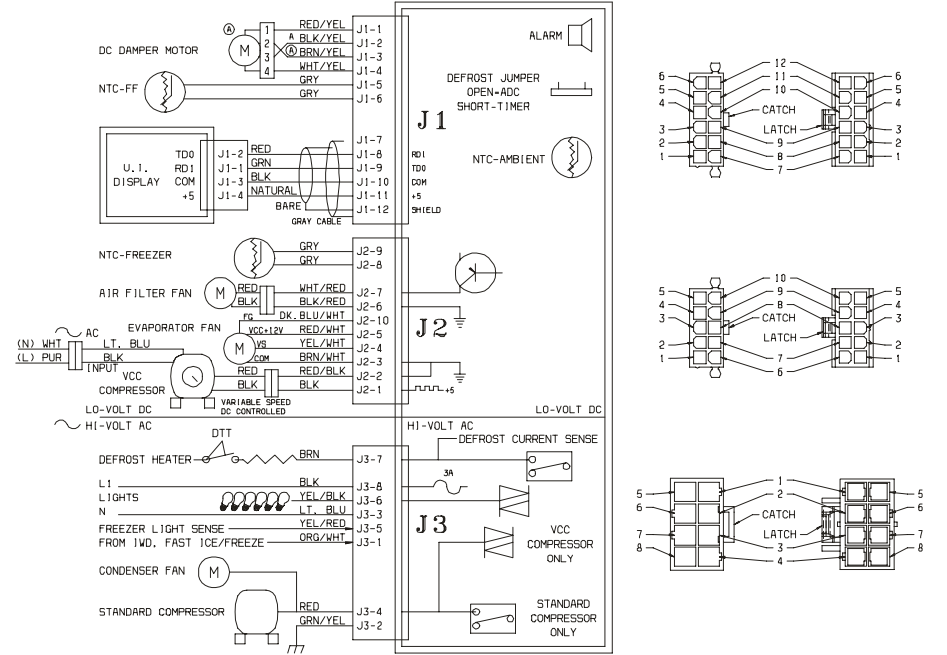
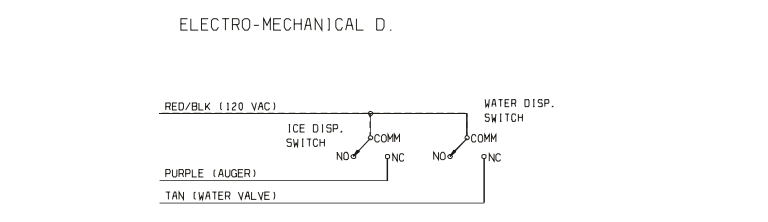
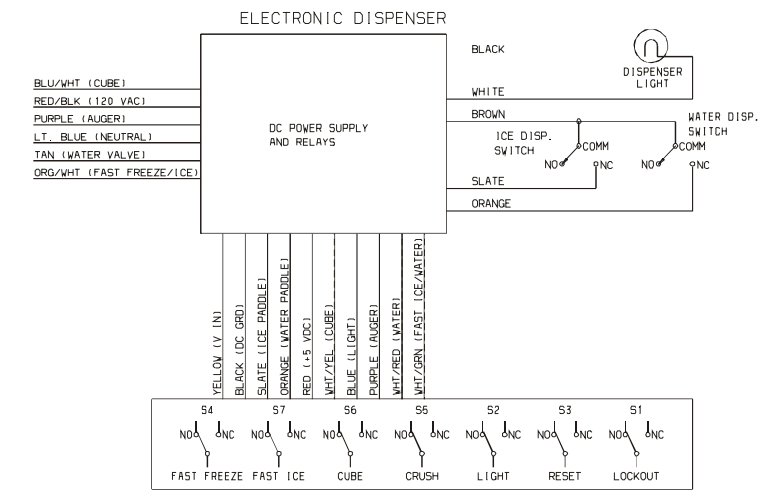
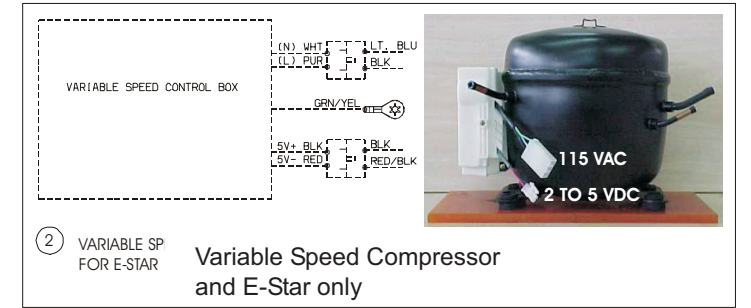
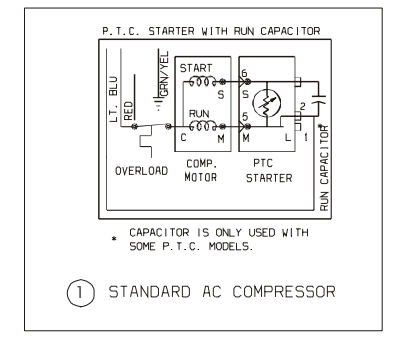
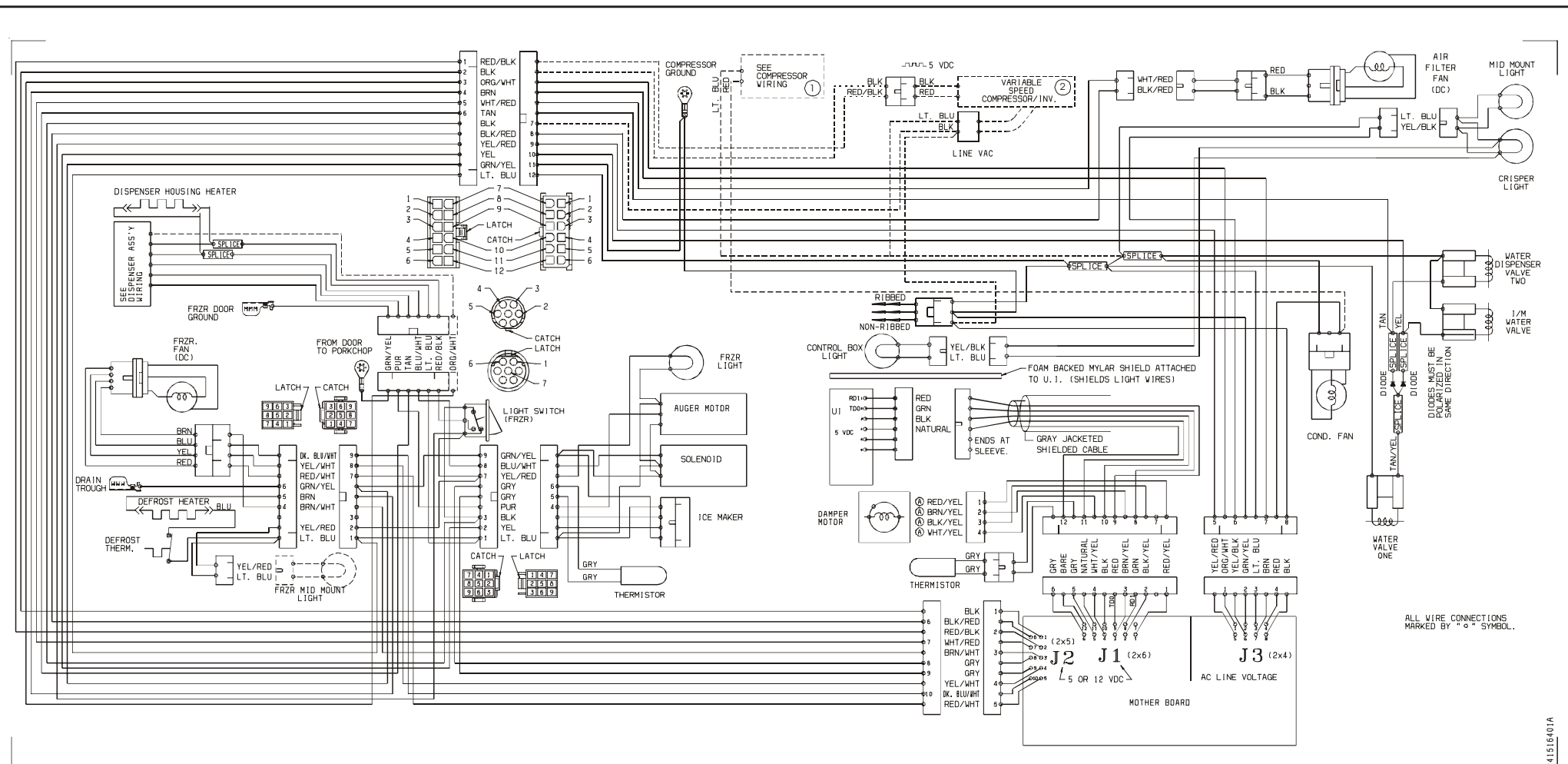

SERVICE PARTS	23 CUBIC FOOT	
	STANDARD ①	E-STAR ②
Compressor Kit *	5303918298	241547601
Power Board (Sigma Main)	N/A	241511102
Inverter	N/A	241577501
Starter/PTC	241527801	N/A
Run Capacitor	218909915	N/A
Sensor, Temperature	240597201	240597201
Damper Assembly	241518401	241518401
Defrost Heater Kit	5303918253	5303918253
Defrost Thermostat Kit	5303918214	5303918214
Evaporator Fan Motor	241509401	241509401
Condenser Fan Motor	241537901	241537901

* Typical Compressor Kit includes compressor, electrical components and filter-drier.

PERFORMANCE DATA NO LOAD AND NO DOOR OPENINGS AT MID-POINT CONTROL SETTING		
Capacitor Run or Induction Run	65°F (18°C) Ambient	90°F (32°C) Ambient
Operating Time	25 to 35%	45 to 55%
Freezer Temperature	2° to 8°F -17° to -13°C	0° to 5°F -18° to -15°C
Refrigerature Temperature	35° to 40°F 2° to 4°C	35° to 40°F 2° to 4°C
Low Side Pressure (cut-in)	8 to 16 psig 55 to 110 kPa	8 to 16 psig 55 to 110 kPa
Low Side Pressure (cut-out)	1 to 4 psig 7 to 28 kPa	1 to 4 psig 7 to 28 kPa
High Side Pressure (Last 1/3 of cycle)	110 to 120 psig 758 to 827 kPa	150 to 175 psig 1034 to 1207 kPa
Wattage (Last 1/3 of cycle)	140 to 185	140 to 185
Amps (Running)	1.1 to 1.6	1.1 to 1.6
Base Voltage	115 VAC (127 VAC Max)	115 VAC (127 VAC Max)

DEFROST SPECIFICATIONS				
Cabinet Size	Thermostat		Heater	
	Cut-in	Cut-out	Watts	Ohms
18' & 21'	25°F -4°C	47°F 8°C	375	35
14', 15' & 17'	25°F -4°C	47°F 8°C	325	41

Mechanical Timer - Defrost 30 Minutes Every 10 Hours of Compressor Run Time
Electronic Timer (ADC) Defrost Up To 24 Minutes Every 6 - 72 Hours of Compressor Run Time

CONDENSER FAN MOTOR		
Watts	RPM	Amps
2.3	1100 CW Opposite Shaft	.15 Running

ICE MAKER SPECIFICATIONS		
Electrical	115 VAC (127 VAC Max)	60 Hertz
Thermostat	Opens at 48°F (9°C)	Closes at 15°F (-9°C)
Heater Wattage	165	

ICE MAKER CONNECTOR PLUG CONNECTIONS		
Wire Number	Wire Color	Connects to:
1	Green/Yellow	Ground
2	Yellow	Water Valve
3	Black	Line
4	Lt. Blue	Neutral

SERVICE DATA SHEET

STANDARD - AUTOMATIC DEFROST TOP FREEZER MODELS (R134a) | P/N: 241588200

IMPORTANT SAFETY NOTICE

The information provided herein is designed to assist qualified repair personnel only. Untrained persons should not attempt to make repairs due to the possibility of electrical shock. Disconnect power cord before servicing.

IMPORTANT

If any green grounding wires are moved during servicing, they must be returned to their original position and properly secured.

CAUTION: All electrical parts and wiring must be shielded from torch flame. Do not allow torch to contact insulation; it will char at 200°F and flash ignite (burn) at 500°F. Excessive heat will distort the plastic liner.

NOTE: Some products come equipped with an Electronic Defrost Control. To initiate defrost, depress the fresh food light switch 5 times in 6 seconds (light bulb must be working). To terminate defrost, depress the fresh food light switch 5 times in 6 seconds.

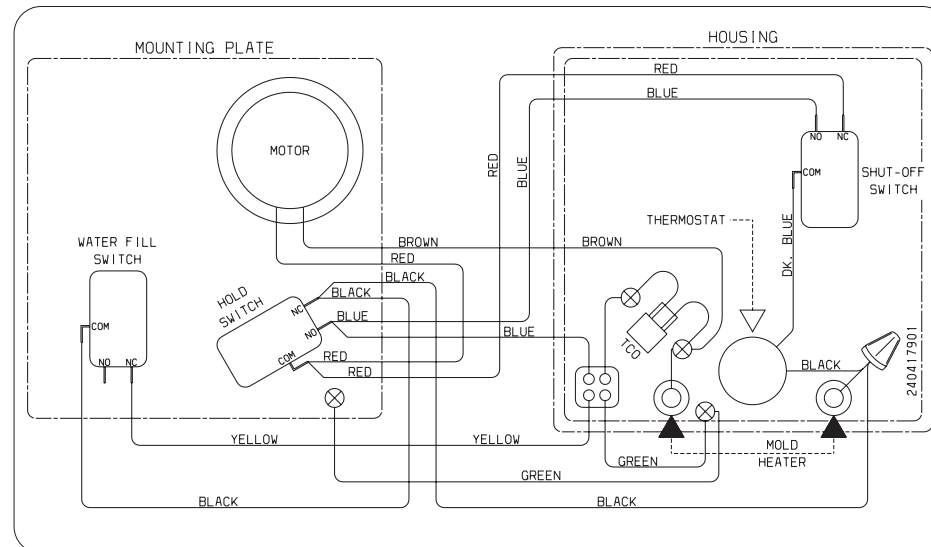

ICE MAKER INFORMATION

Test Cycling

Remove cover by inserting screwdriver in notch at bottom and prying cover from housing. Use screwdriver to rotate motor gear counterclockwise until *Holding Switch* circuit is completed. All components of ice maker should function to complete the cycle.

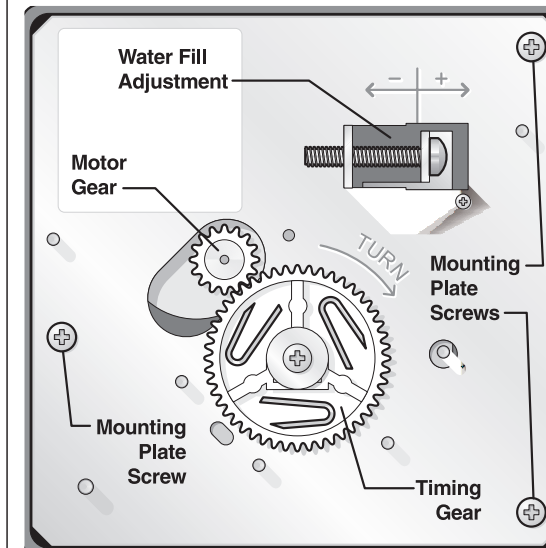

Water Fill Volume

The water fill adjustment screw will change the fill time. One full turn is equal to 20cc (.68 oz.). The correct fill is 95 to 105cc (3.2 to 3.6 oz.). When a water valve is replaced, the fill volume must be checked.

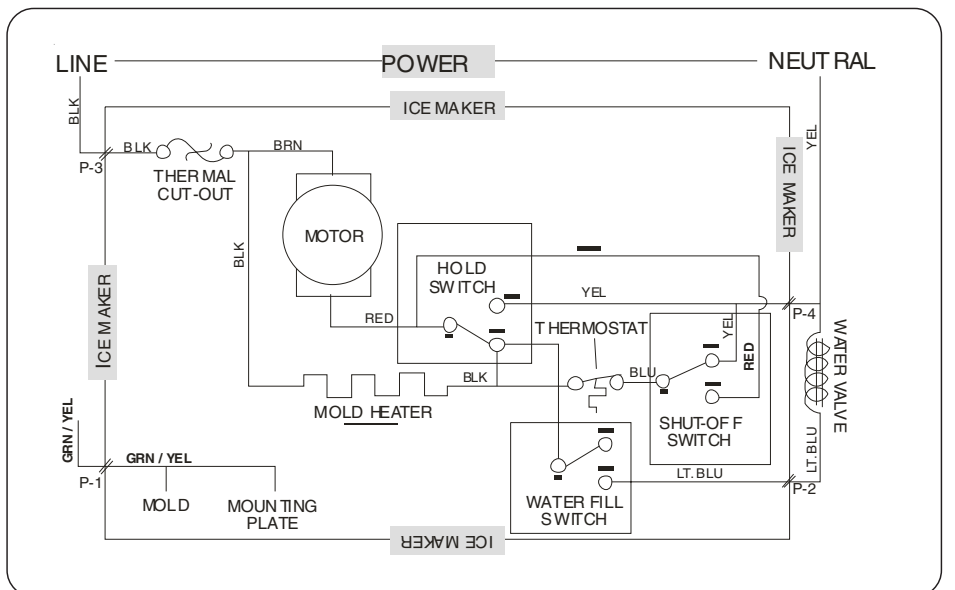

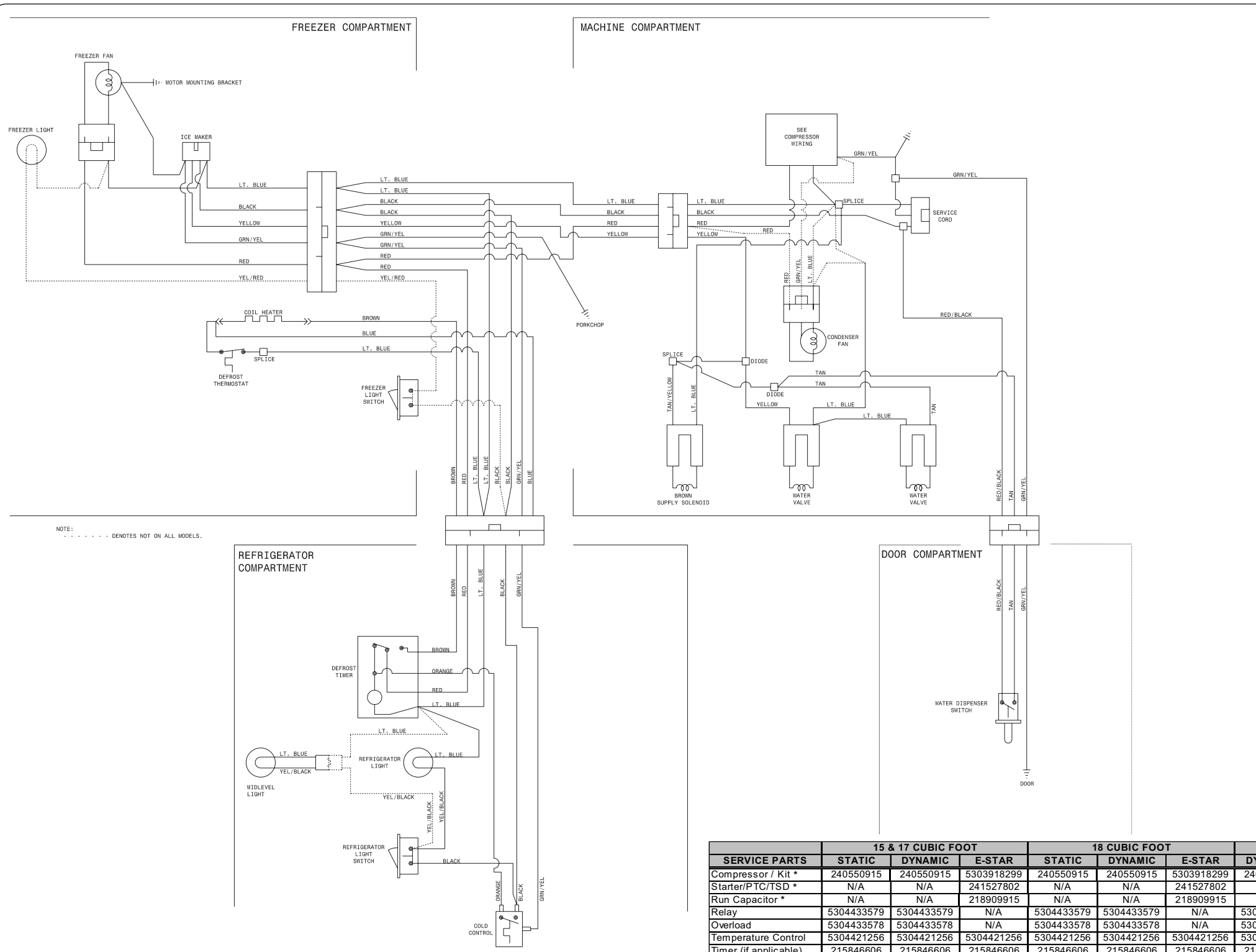

LADDER SCHEMATIC-TM DYNAMIC WITH WATER THRU DOOR MODELS

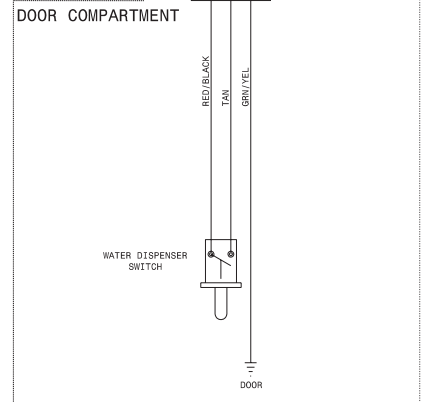
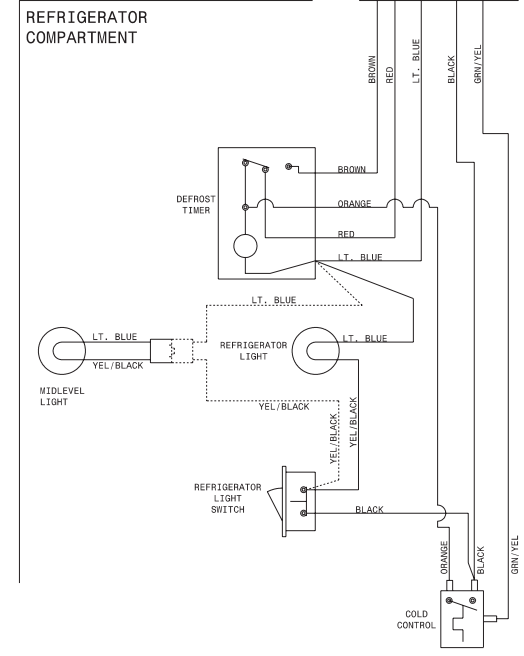
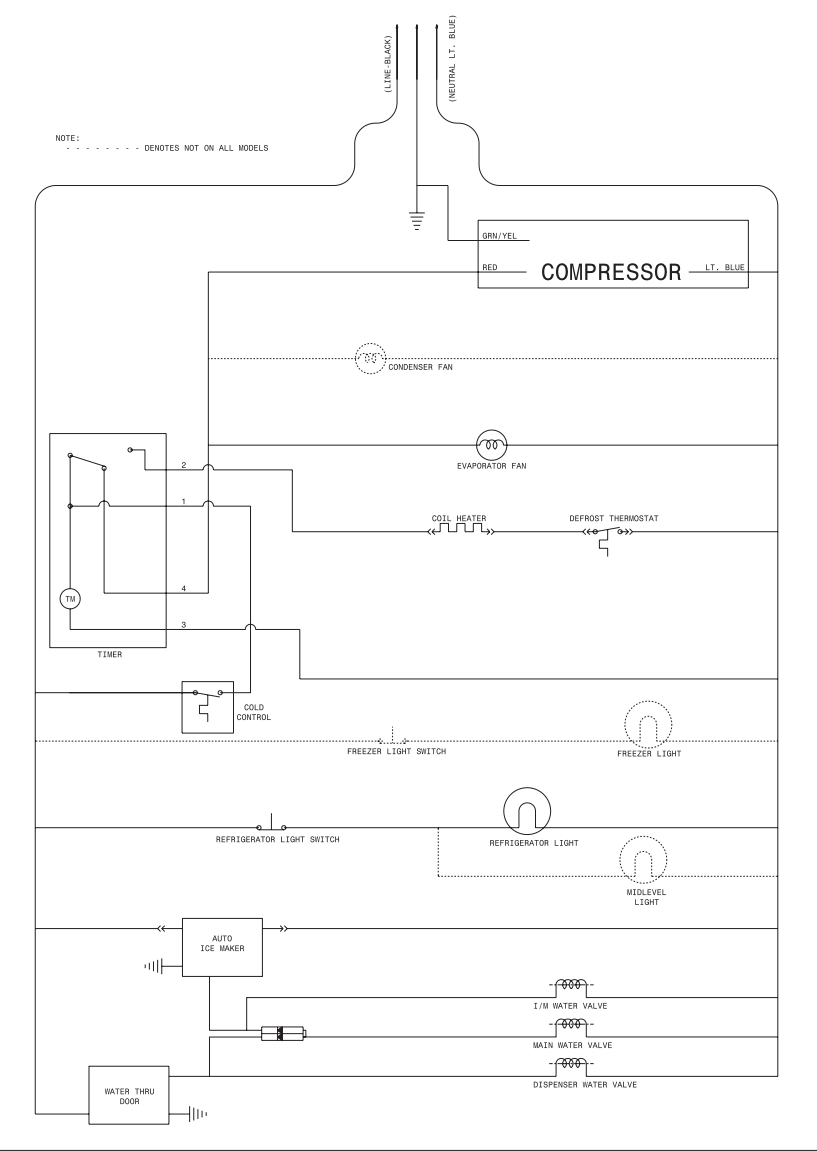

SERVICE PARTS	15 & 17 CUBIC FOOT			18 CUBIC FOOT			21 CUBIC FOOT	
	STATIC	DYNAMIC	E-STAR	STATIC	DYNAMIC	E-STAR	DYNAMIC	E-STAR
Compressor / Kit *	240550915	240550915	5303918299	240550915	240550915	5303918299	240550915	5303918299
Starter/PTC/TSD *	N/A	N/A	241527802	N/A	N/A	241527802	N/A	241527802
Run Capacitor *	N/A	N/A	218909915	N/A	N/A	218909915	N/A	218909915
Relay	5304433579	5304433579	N/A	5304433579	5304433579	N/A	5304433579	N/A
Overload	5304433578	5304433578	N/A	5304433578	5304433578	N/A	5304433578	N/A
Temperature Control	5304421256	5304421256	5304421256	5304421256	5304421256	5304421256	5304421256	5304421256
Timer (if applicable)	215846606	215846606	215846606	215846606	215846606	215846606	215846606	215846606
ADC (if applicable)	N/A	N/A	N/A	N/A	N/A	N/A	N/A	N/A
Defrost Heater Kit	5303918203	5303918203	5303918203	5303918208	5303918208	5303918208	5303918247	5303918247
Defrost Thermostat Kit	5303918202	5303918202	5303918202	5303918202	5303918202	5303918202	5303918202	5303918202
Evaporator Fan Motor	240369701	240369701	240369701	240369701	240369701	240369701	240369701	240369701
Condenser Fan Motor	N/A	240523601	240523601	N/A	240523601	240523601	240334001	240334001

* Typical compressor kit includes compressor, electrical components, and filter-drier

COMPRESSOR WIRING

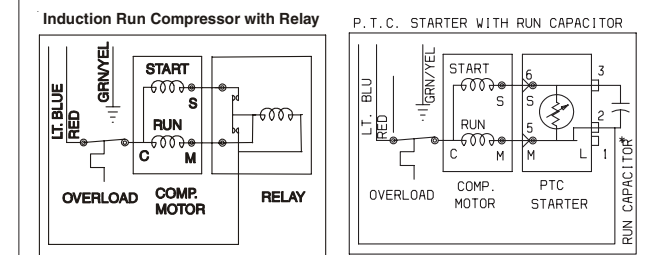

* CAPACITOR IS ONLY USED WITH SOME P.T.C. MODELS.

PERFORMANCE DATA NO LOAD AND NO DOOR OPENINGS AT MID-POINT CONTROL SETTING		
Capacitor Run or Induction Run	65°F (18°C) Ambient	90°F (32°C) Ambient
Operating Time	25 to 35%	45 to 55%
Freezer Temperature	2° to 8°F -17° to -13°C	0° to 5°F -18° to -15°C
Refrigerature Temperature	35° to 40°F 2° to 4°C	35° to 40°F 2° to 4°C
Low Side Pressure (cut-in)	8 to 16 psig 55 to 110 kPa	8 to 16 psig 55 to 110 kPa
Low Side Pressure (cut-out)	1 to 4 psig 7 to 28 kPa	1 to 4 psig 7 to 28 kPa
High Side Pressure (Last 1/3 of cycle)	110 to 120 psig 758 to 827 kPa	150 to 175 psig 1034 to 1207 kPa
Wattage (Last 1/3 of cycle)	140 to 185	140 to 185
Amps (Running)	1.1 to 1.6	1.1 to 1.6
Base Voltage	115 VAC (127 VAC Max)	115 VAC (127 VAC Max)

DEFROST SPECIFICATIONS				
Cabinet Size	Thermostat		Heater	
	Cut-in	Cut-out	Watts	Ohms
18' & 21'	25°F -4°C	47°F 8°C	375	35
14', 15' & 17'	25°F -4°C	47°F 8°C	325	41

Mechanical Timer - Defrost 30 Minutes Every 10 Hours of Compressor Run Time
Electronic Timer (ADC) Defrost Up To 24 Minutes Every 6 - 72 Hours of Compressor Run Time

CONDENSER FAN MOTOR		
Watts	RPM	Amps
2.3	1100 CW Opposite Shaft	.15 Running

ICE MAKER SPECIFICATIONS		
Electrical	115 VAC (127 VAC Max)	60 Hertz
Thermostat	Opens at 48°F (9°C)	Closes at 15°F (-9°C)
Heater Wattage	165	

ICE MAKER CONNECTOR PLUG CONNECTIONS		
Wire Number	Wire Color	Connects to:
1	Green/Yellow	Ground
2	Yellow	Water Valve
3	Black	Line
4	Lt. Blue	Neutral

SERVICE DATA SHEET

STANDARD - AUTOMATIC
DEFROST TOP FREEZER MODELS (R134a) | P/N: 241588201

IMPORTANT SAFETY NOTICE

The information provided herein is designed to assist qualified repair personnel only. Untrained persons should not attempt to make repairs due to the possibility of electrical shock. Disconnect power cord before servicing.

IMPORTANT

If any green grounding wires are moved during servicing, they must be returned to their original position and properly secured.

CAUTION: All electrical parts and wiring must be shielded from torch flame. Do not allow torch to contact insulation; it will char at 200°F and flash ignite (burn) at 500°F. Excessive heat will distort the plastic liner.

NOTE: Some products come equipped with an Electronic Defrost Control. To initiate defrost, depress the fresh food light switch 5 times in 6 seconds (light bulb must be working). To terminate defrost, depress the fresh food light switch 5 times in 6 seconds.

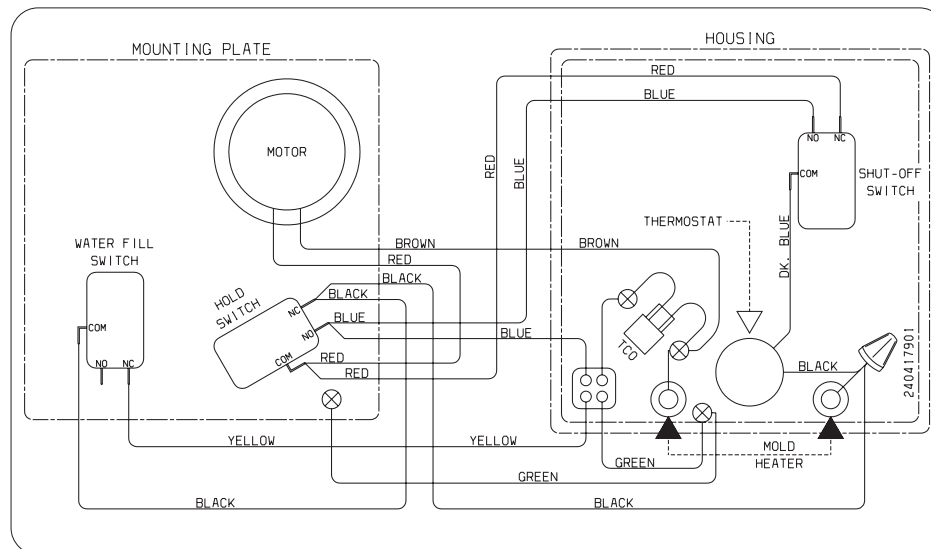

ICE MAKER INFORMATION

Test Cycling

Remove cover by inserting screwdriver in notch at bottom and prying cover from housing. Use screwdriver to rotate motor gear counterclockwise until *Holding Switch* circuit is completed. All components of ice maker should function to complete the cycle.

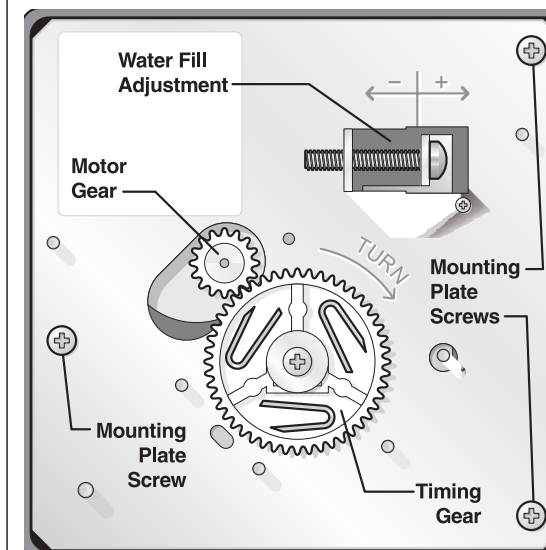

Water Fill Volume

The water fill adjustment screw will change the fill time. One full turn is equal to 20cc (.68 oz.). The correct fill is 95 to 105cc (3.2 to 3.6 oz.). When a water valve is replaced, the fill volume must be checked.

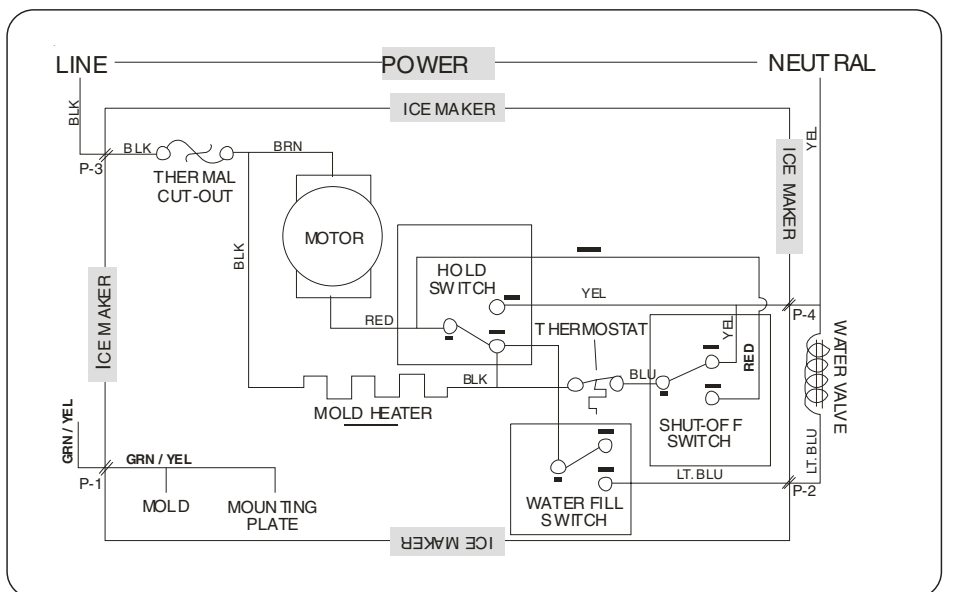

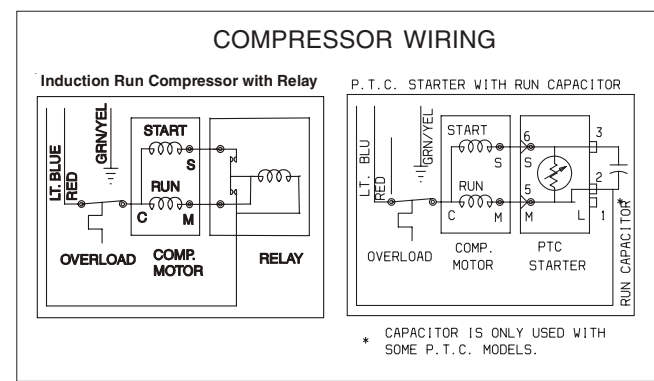
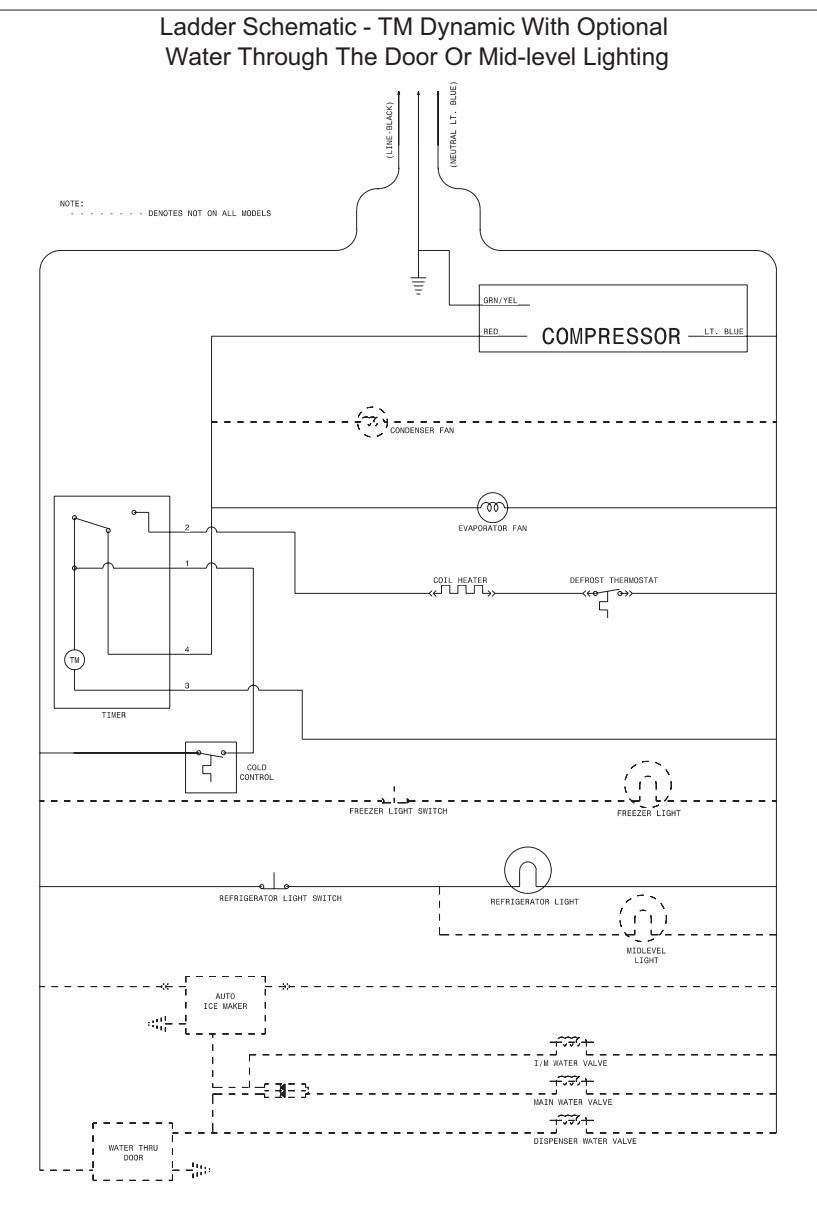
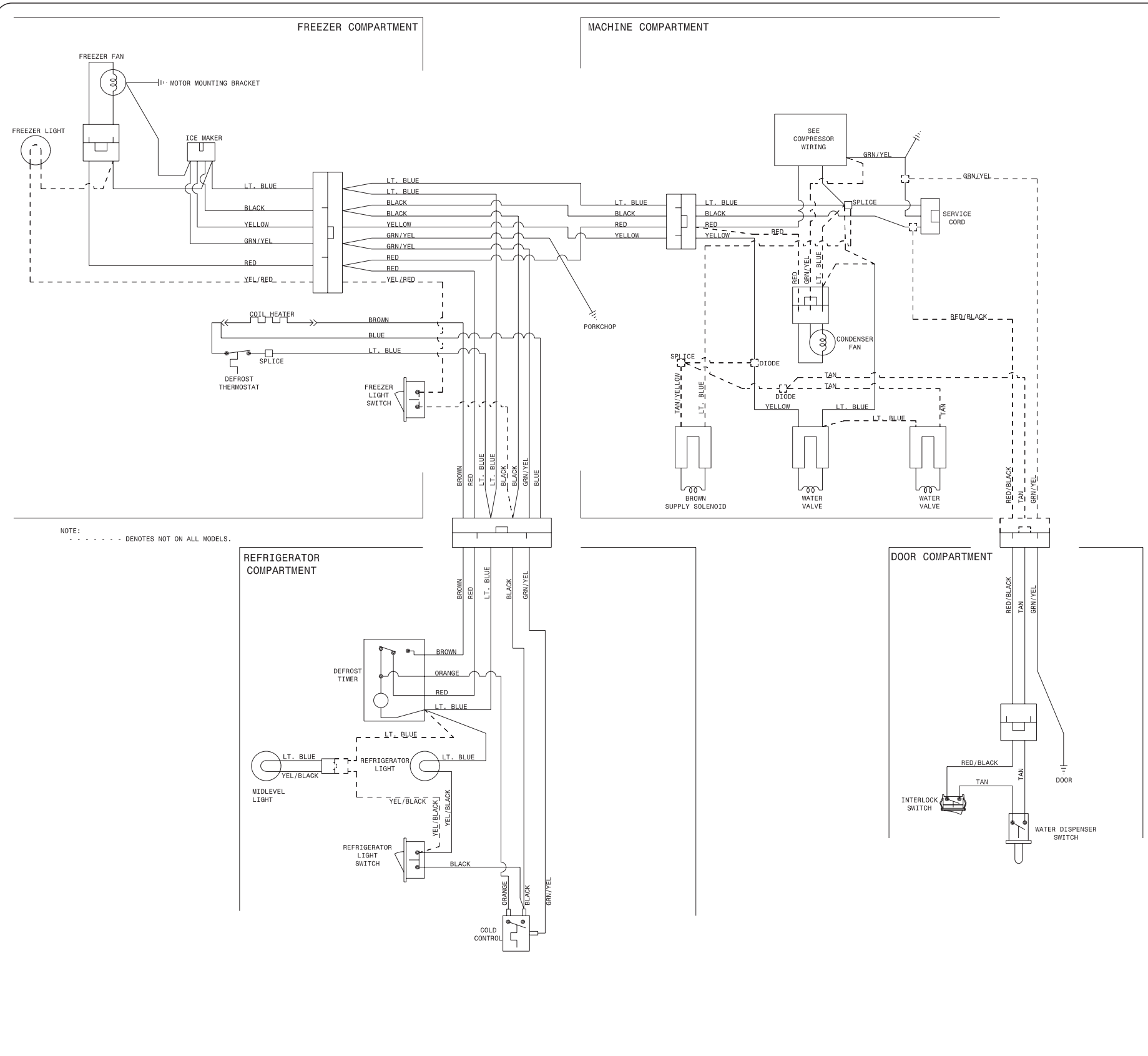

PERFORMANCE DATA NO LOAD AND NO DOOR OPENINGS AT MID-POINT CONTROL SETTING				
Type A With Run/Start Capacitor	65°F (18°C) Ambient	90°F (32°C) Ambient		
Operating Time	32 to 40%	55 to 65%		
Freezer Temperature	0° to 4°F -18° to -16°C	-1° to 3°F -18° to -16°C		
Refrigerator Temperature	34° to 39°F 1° to 4°C	34° to 39°F 1° to 4°C		
Low Side Pressure (cut-in)	5 to 12 psig 34 to 83 kPa	5 to 12 psig 34 to 83 kPa		
Low Side Pressure (cut-out)	-2 to 2 psig -14 to 14 kPa	-2 to 2 psig -14 to 14 kPa		
High Side Pressure (Last 1/3 of cycle)	90 to 115 psig 621 to 793 kPa	130 to 155 psig 896 to 1069 kPa		
Wattage (Last 1/3 of cycle)	120 to 150	130 to 160		
Amps (Running)	1.2 to 1.5	1.2 to 1.5		
Base Voltage	115 vac (127 vac max)	115 vac (127 vac max)		
DEFROST SPECIFICATIONS				
Cabinet Size	Thermostat		Heater	
	Cut-in	Cut-out	Watts	Ohms
23' & 26'	25°F -4°C	47°F 8°C	450	30
Electronic Timer - (ADC) Defrost 24 minutes every 6 to 72 hours of compressor run time.				
CONDENSER FAN MOTOR				
Watts	RPM	Amps		
7	1100 CW Opposite Shaft	.1 Running		
ICE MAKER SPECIFICATIONS				
Electrical	115 vac (127 vac max)	60 Hertz		
Thermostat	Opens at 48°F (9°C)	Closes at 15°F (-9°C)		
Heater Wattage	165			
ICE MAKER CONNECTOR PLUG CONNECTIONS				
Wire Number	Wire Color	Connects to:		
1	Green/Yellow	Ground		
2	Yellow	Water Valve		
3	Black	Line		
4	Lt. Blue	Neutral		

SERVICE DATA SHEET - 241636600
R134a
ICE & WATER - AUTOMATIC DEFROST
SIDE BY SIDE MODELS

IMPORTANT SAFETY NOTE
The information provided herein is designed to assist qualified repair personnel only. Untrained persons should not attempt to make repairs due to the possibility of electrical shock. Disconnect power cord before servicing this appliance.
IMPORTANT
If any green grounding wires are removed during servicing, they must be returned to their original position and properly secured.

CAUTION
All electrical parts and wiring must be shielded from torch flame. DO NOT allow torch to touch insulation; it will char at 200°F and flash ignite (burn) at 500°F. Excessive heat will distort the plastic liner.

NOTE
This product comes equipped with an Electronic Defrost Control. To initiate defrost, depress the fresh food light switch 5 times in 6 seconds (light bulb must be working). To terminate defrost, depress the fresh food light switch 5 times in 6 seconds.

ICE MAKER INFORMATION

Test Cycling
Press the momentary contact on the ON/OFF switch for approximately 15 seconds. Ice maker will continue to complete the cycle.

Water Fill Volume
Remove cover by inserting screwdriver in notch at bottom and prying cover from housing. The water fill adjustment screw will change the fill time. One turn is equal to 20cc (.68 oz.). The correct fill is 102 to 110cc (3.25 to 3.5 oz.). When a water valve is replaced, the fill volume must be checked

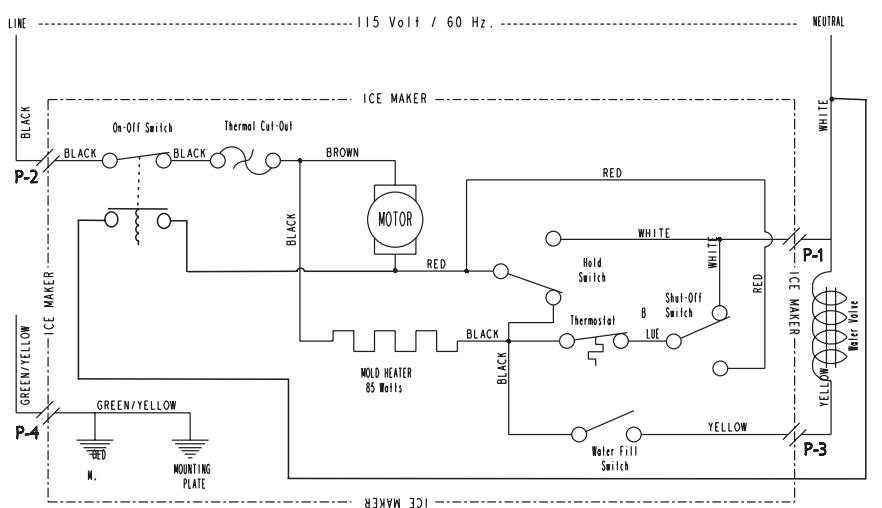
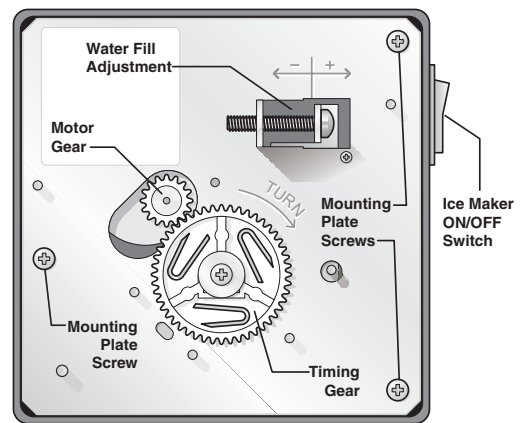

ELECTRONIC DISPENSER

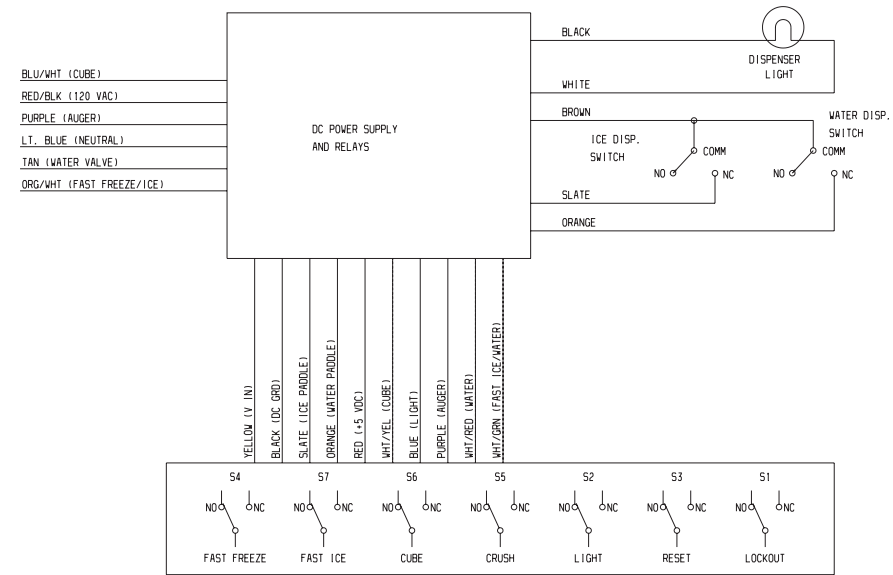

ELECTRO-MECHANICAL DISPENSER

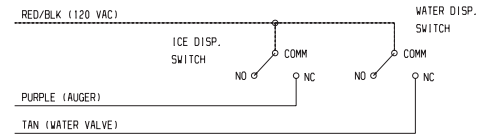

P.T.C. STARTER WITH RUN CAPACITOR

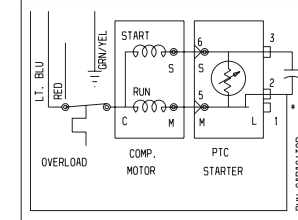

* CAPACITOR IS ONLY USED WITH SOME P.T.C. MODELS.

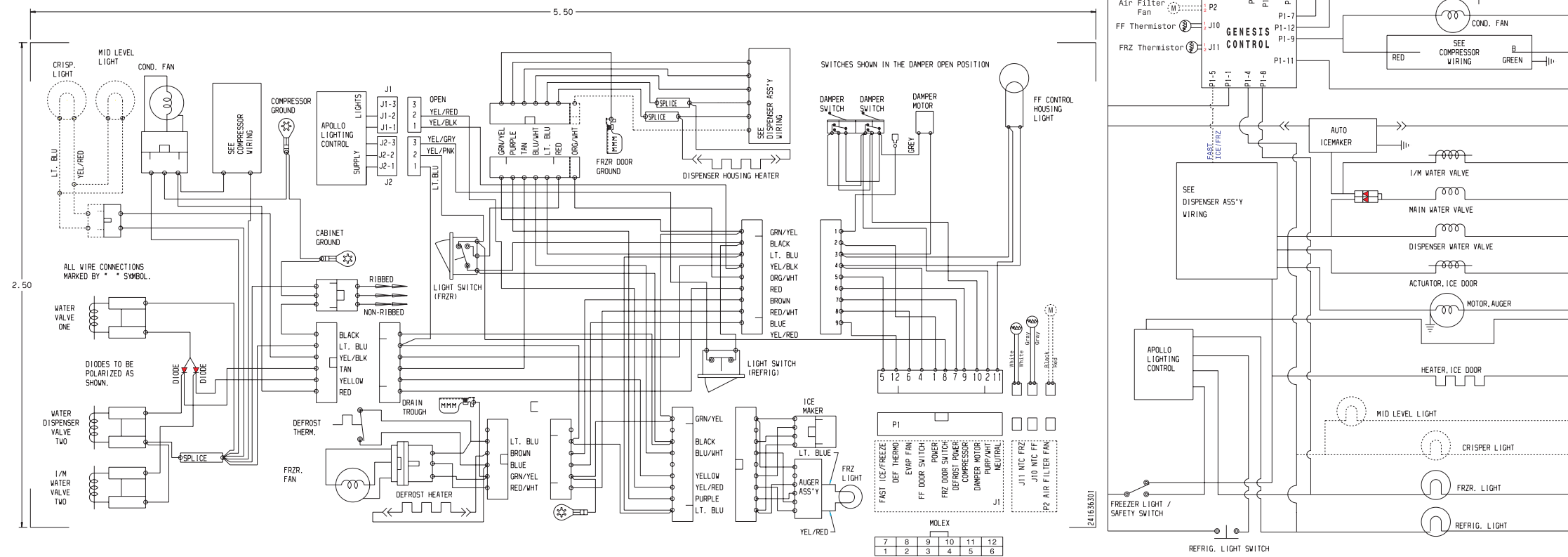

PERFORMANCE DATA NO LOAD AND NO DOOR OPENINGS AT MID-POINT CONTROL SETTING				
Type A With Run/Start Capacitor	65°F (18°C) Ambient	90°F (32°C) Ambient		
Operating Time	32 to 40%	55 to 65%		
Freezer Temperature	0° to 4°F -18° to -16°C	-1° to 3°F -18° to -16°C		
Refrigerator Temperature	34° to 39°F 1° to 4°C	34° to 39°F 1° to 4°C		
Low Side Pressure (cut-in)	5 to 12 psig 34 to 83 kPa	5 to 12 psig 34 to 83 kPa		
Low Side Pressure (cut-out)	-2 to 2 psig -14 to 14 kPa	-2 to 2 psig -14 to 14 kPa		
High Side Pressure (Last 1/3 of cycle)	90 to 115 psig 621 to 793 kPa	130 to 155 psig 896 to 1069 kPa		
Wattage (Last 1/3 of cycle)	120 to 150	130 to 160		
Amps (Running)	1.2 to 1.5	1.2 to 1.5		
Base Voltage	115 vac (127 vac max)	115 vac (127 vac max)		
DEFROST SPECIFICATIONS				
Cabinet Size	Thermostat		Heater	
	Cut-in	Cut-out	Watts	Ohms
23' & 26'	25°F -4°C	47°F 8°C	450	30
Electronic Timer - (ADC) Defrost 24 minutes every 6 to 72 hours of compressor run time.				
CONDENSER FAN MOTOR				
Watts	RPM	Amps		
7	1100 CW Opposite Shaft	.1 Running		
ICE MAKER SPECIFICATIONS				
Electrical	115 vac (127 vac max)	60 Hertz		
Thermostat	Opens at 48°F (9°C)		Closes at 15°F (-9°C)	
Heater Wattage	165			
ICE MAKER CONNECTOR PLUG CONNECTIONS				
Wire Number	Wire Color	Connects to:		
1	Green/Yellow	Ground		
2	Yellow	Water Valve		
3	Black	Line		
4	Lt. Blue	Neutral		

SERVICE DATA SHEET - 241636601
R134a
ICE & WATER - AUTOMATIC DEFROST
SIDE BY SIDE MODELS

IMPORTANT SAFETY NOTE

The information provided herein is designed to assist qualified repair personnel only. Untrained persons should not attempt to make repairs due to the possibility of electrical shock. Disconnect power cord before servicing this appliance.

IMPORTANT

If any green grounding wires are removed during servicing, they must be returned to their original position and properly secured.

CAUTION

All electrical parts and wiring must be shielded from torch flame. DO NOT allow torch to touch insulation; it will char at 200°F and flash ignite (burn) at 500°F. Excessive heat will distort the plastic liner.

NOTE

This product comes equipped with an Electronic Defrost Control. To initiate defrost, depress the fresh food light switch 5 times in 6 seconds (light bulb must be working). To terminate defrost, depress the fresh food light switch 5 times in 6 seconds.

ICE MAKER INFORMATION

Test Cycling

Press the momentary contact on the ON/OFF switch for approximately 15 seconds. Ice maker will continue to complete the cycle.

Water Fill Volume

Remove cover by inserting screwdriver in notch at bottom and prying cover from housing. The water fill adjustment screw will change the fill time. One turn is equal to 20cc (.68 oz.). The correct fill is 102 to 110cc (3.25 to 3.5 oz.). When a water valve is replaced, the fill volume must be checked

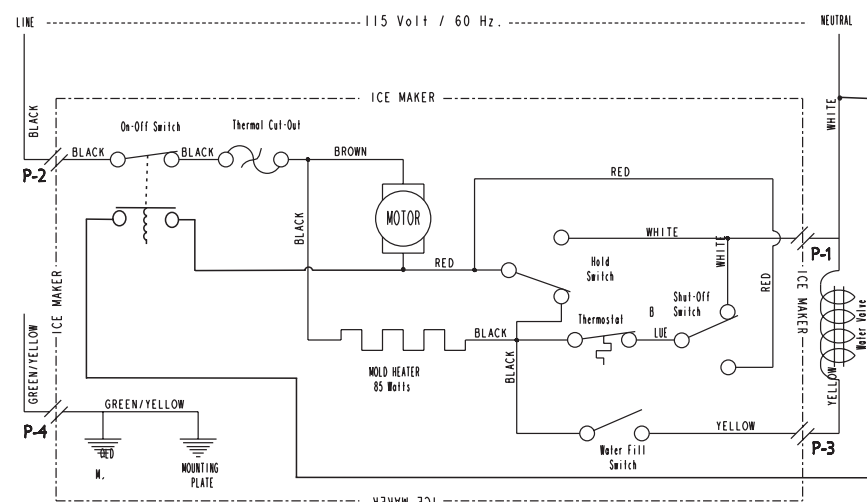
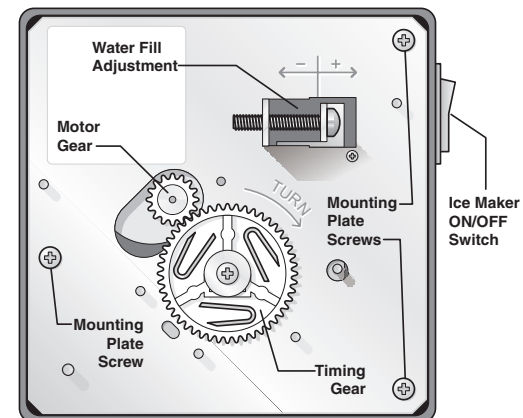

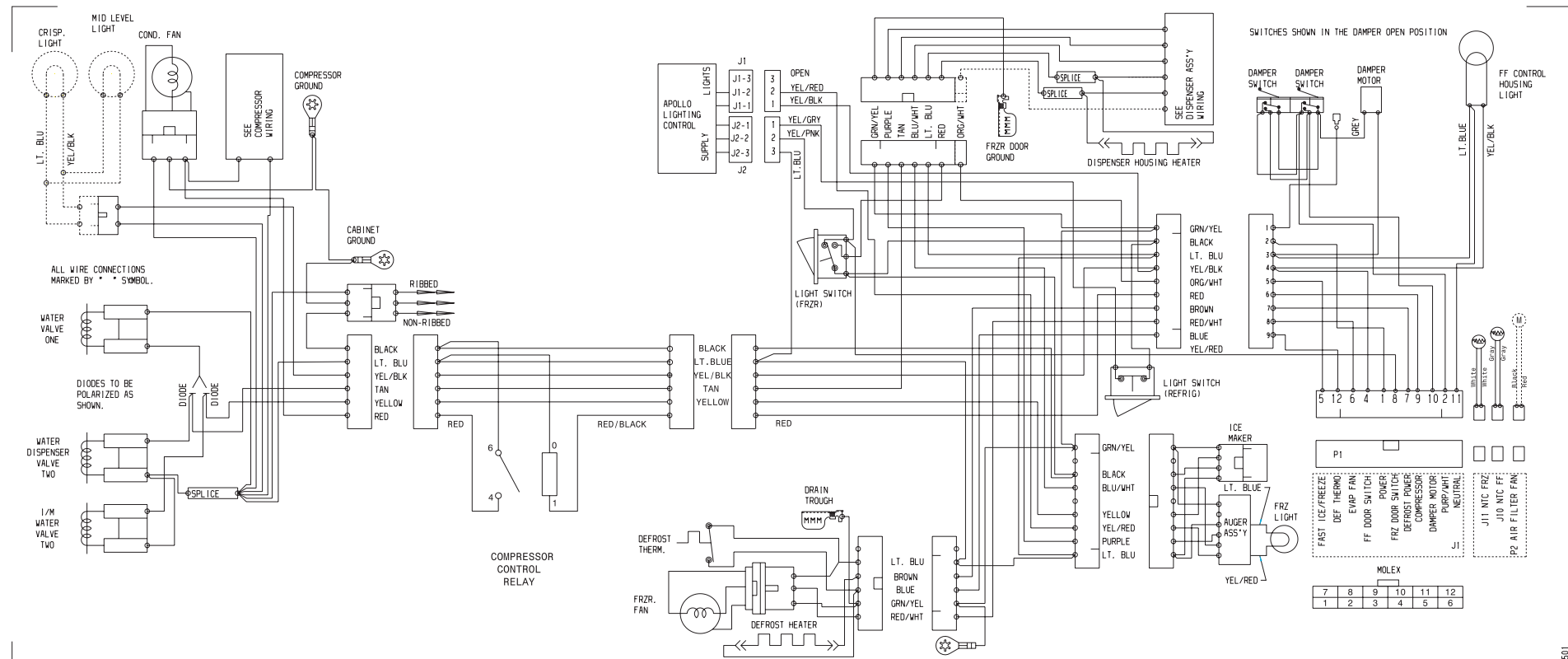

241660501

ELECTRONIC DISPENSER

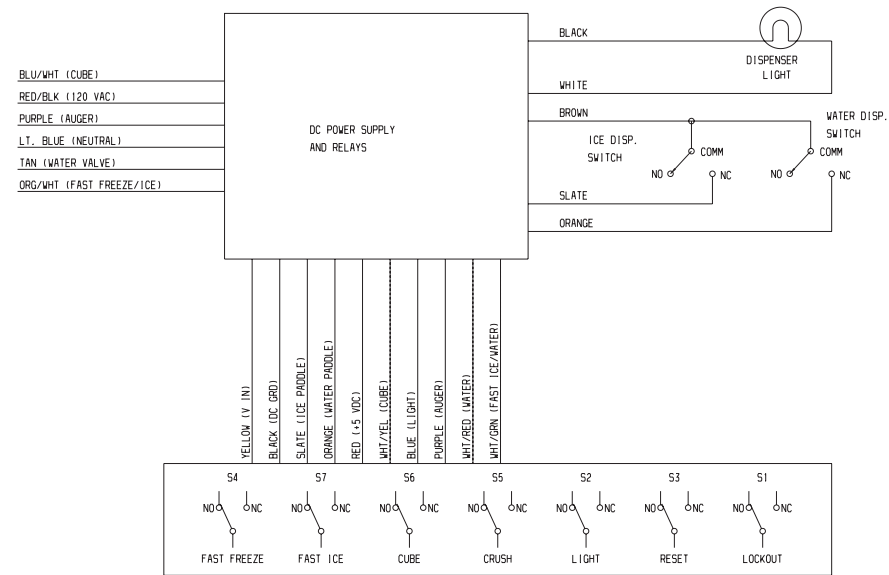

ELECTRO-MECHANICAL DISPENSER

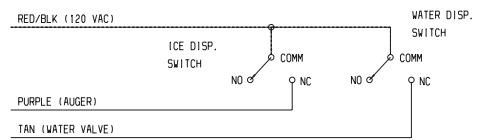

P. T. C. STARTER WITH RUN CAPACITOR

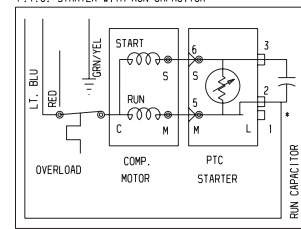

* CAPACITOR IS ONLY USED WITH SOME P. T. C. MODELS.

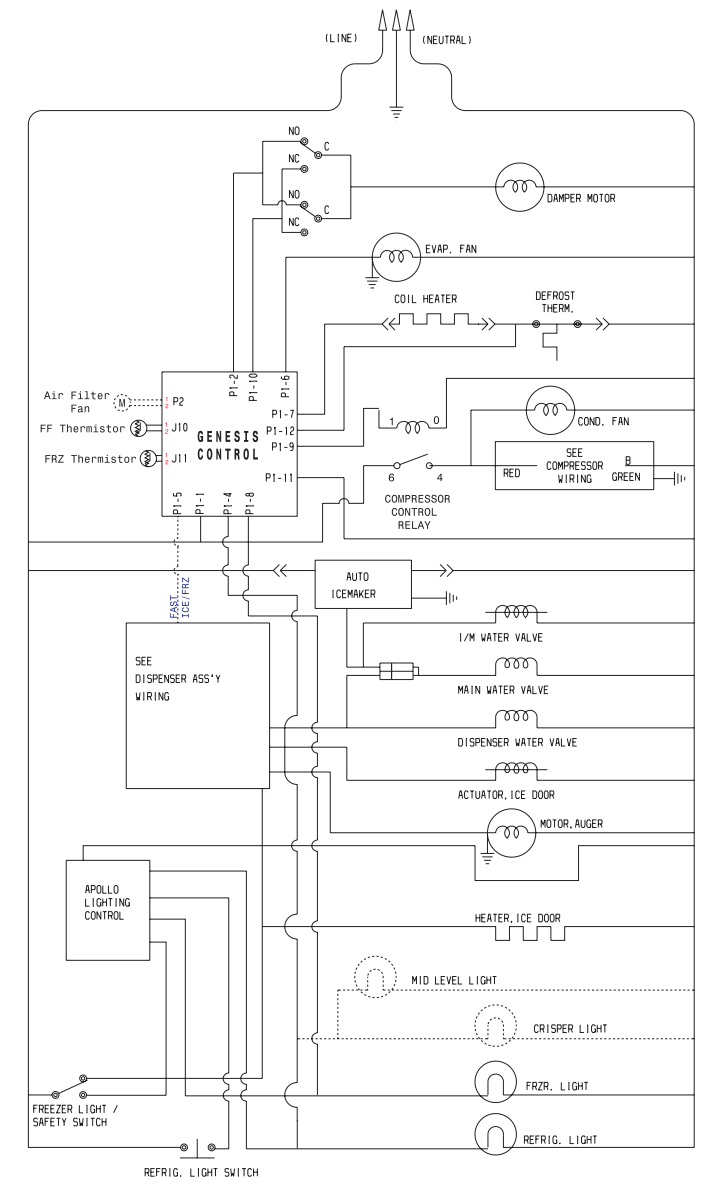



PERFORMANCE DATA				
NO LOAD AND NO DOOR OPENINGS AT MID-POINT CONTROL SETTING				
Type A with Run/Start Capacitor	65°F (18°C) Ambient		90°F (32°C) Ambient	
	Variable Speed	Standard	Variable Speed	Standard
Operating Time	74 to 84%	32 to 40%	100%	55 to 65%
Freezer Temperature	-2° to 2°F -19° to -17°C	0° to 4°F -18° to -16°C	-1° to 3°F -18° to -16°C	-1° to 3°F -18° to -16°C
Refrigerator Temperature	34° to 39°F 1° to 4°C	34° to 39°F 1° to 4°C	34° to 39°F 1° to 4°C	34° to 39°F 1° to 4°C
Low Side Pressure (cut-in)	5 to 12 psig 43 to 83 kPa	5 to 12 psig 43 to 83 kPa	N/A	5 to 12 psig 43 to 83 kPa
Low Side Pressure (cut-out)	-2 to 2 psig -14 to 14kPa	-2 to 2 psig -14 to 14kPa	-2 to 2 psig -14 to 14kPa	-2 to 2 psig -14 to 14kPa
High Side Pressure (last 1/3 cycle)	90 to 105 psig 621 to 724 kPa	90 to 115 psig 621 to 793 kPa	120 to 135 psig 827 to 931 kPa	130 to 155 psig 896 to 1069 kPa
Wattage (last 1/3 cycle)	60 to 65	120 to 150	65 to 80	130 to 160
Amps (running)	.7 to 1.1	1.0 to 1.4	.9 to 1.3	1.1 to 1.5
Base Voltage	115 vac (127 vac max)		115 vac (127 vac max)	
DEFROST SPECIFICATIONS				
Cabinet Size	Thermostat		Heater	
	Cut-in	Cut-out	Watts	Ohms
23"	25°F (-4°C)	47°F (8°C)	450	30
Electronic Timer – (ADC) Defrost 24 minutes every 6 – 96 hours of compressor run time.				
CONDENSER FAN MOTOR				
Watts	RPM		Amps	
2.8	950 CW Opposite Shaft		.1 Running	
ICE MAKER SPECIFICATIONS				
Electrical	115 vac (127 vac max)			
Thermostat	Opens at 48°F (9°C)		Closes at 15°F (-9°C)	
Heater Voltage	85 vac			
ICE MAKER CONNECTOR PLUG CONNECTIONS				
Wire Number	Wire Color	Connects to:		
1	Green/Yellow	Ground		
2	Yellow	Water Valve		
3	Black	Line		
4	Light Blue	Neutral		

IMPORTANT

Please return this sheet to its original location.

SERVICE DATA SHEET

241639000

ICE & WATER - AUTOMATIC DEFROST
COUNTER DEPTH SIDE BY SIDE - R134a

IMPORTANT SAFETY NOTE

The information provided herein is designed to assist qualified repair personnel only. Untrained persons should not attempt to make repairs due to the possibility of electrical shock. Disconnect power cord before servicing this appliance.

IMPORTANT

If any green grounding wires are removed during servicing, they must be returned to their original position and properly secured.

CAUTION

All electrical parts and wiring must be shielded from torch flame. DO NOT allow torch to touch insulation; it will char at 200°F and flash ignite (burn) at 500°F. Excessive heat will distort the plastic liner.

NOTE

This product comes equipped with an Adaptive Defrost Control (ADC). To activate manual defrost, press and hold the Freezer temperature UP (WARMER) key while pressing the Fresh Food temperature DOWN (COLDER) key 5 times within 6 seconds. A "d" in the freezer temperature window and "F" in the refrigerator temperature window will display when the heater is activated. To deactivate manual defrost, press and hold Freezer temperature UP (WARMER) key while pressing the Fresh Food temperature DOWN (COLDER) key 5 times within 6 seconds. "d" and "F" will be displayed until the defrost cycle is complete. (approx. 8 minutes)

ICE MAKER INFORMATION

Test Cycling

Press the momentary contact on the ON/OFF switch for approximately 15 seconds. Ice maker will continue to complete the cycle.

Water Fill Volume

Remove cover by inserting screwdriver in notch at bottom and prying cover from housing. The water fill adjustment screw will change the fill time. One turn is equal to 20cc (.68 oz.). The correct fill is 102 to 110cc (3.25 to 3.5 oz.). When a water valve is replaced, the fill volume must be checked.

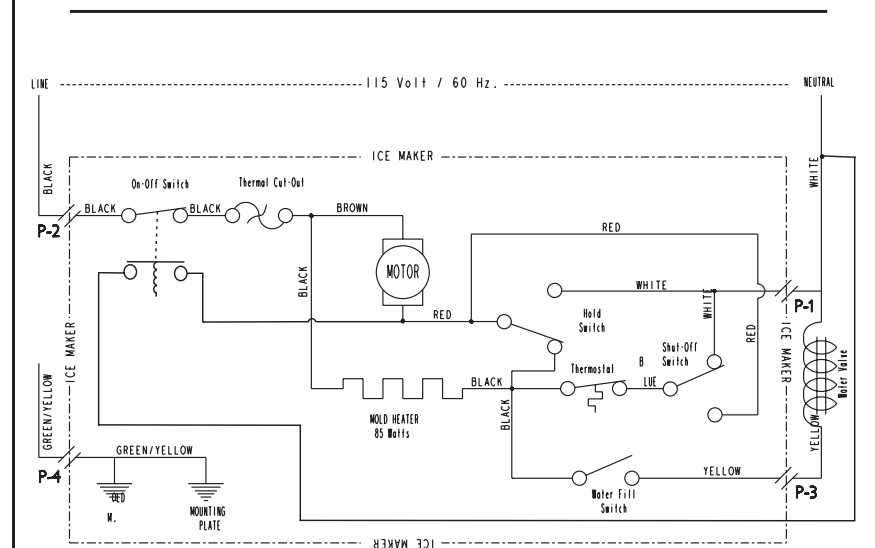
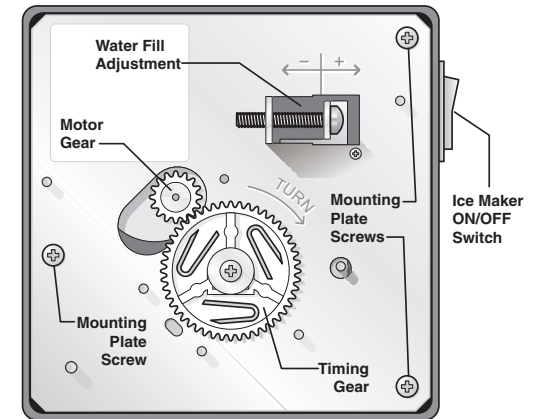

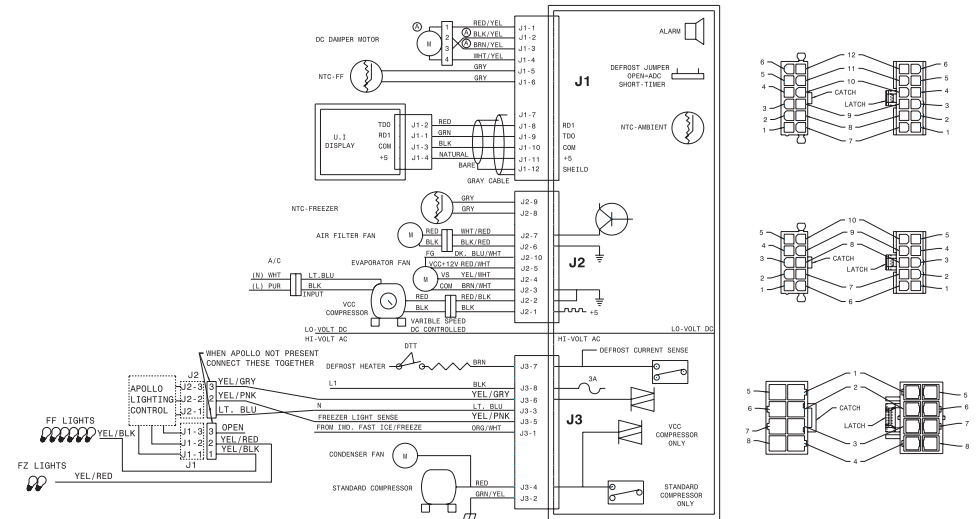
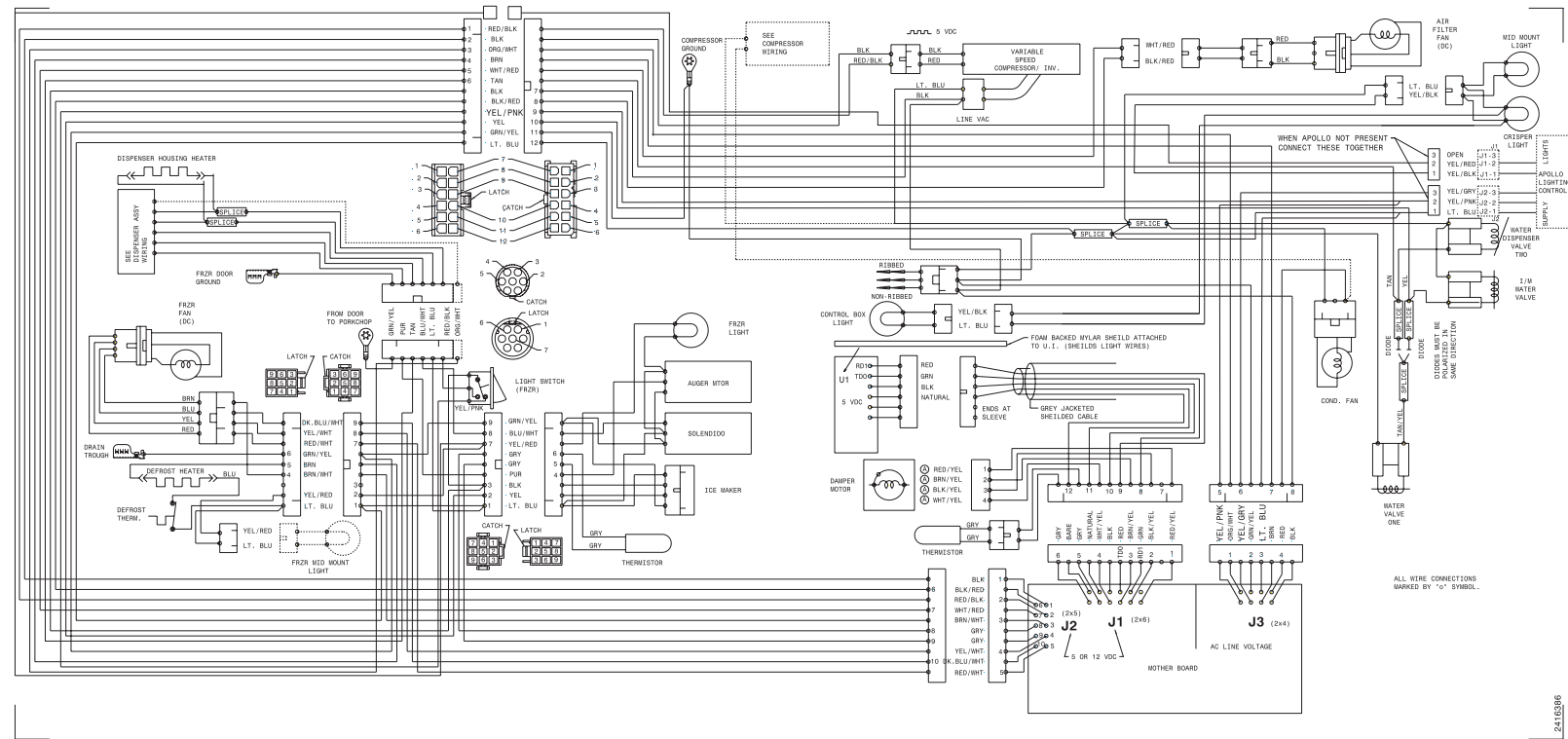
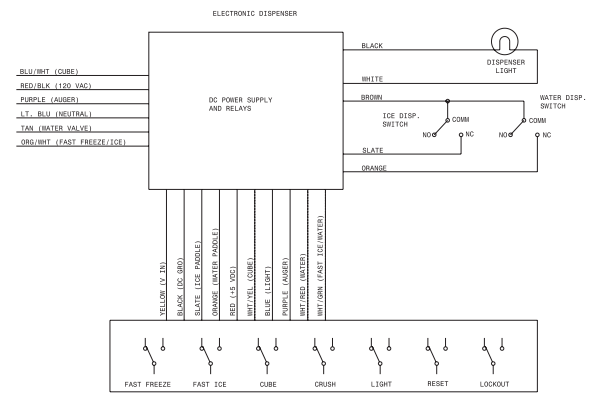
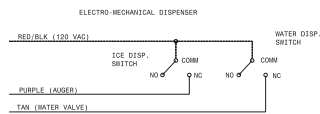
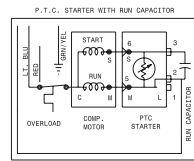
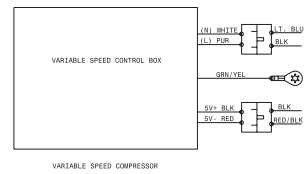

PERFORMANCE DATA NO LOAD AND NO DOOR OPENINGS AT MID-POINT CONTROL SETTING		
Capacitor Run or Induction Run	65°F (18°C) Ambient	90°F (32°C) Ambient
Operating Time	25 to 35%	45 to 55%
Freezer Temperature	2° to 8°F -17° to -13°C	0° to 5°F -18° to -15°C
Refrigerature Temperature	35° to 40°F 2° to 4°C	35° to 40°F 2° to 4°C
Low Side Pressure (cut-in)	8 to 16 psig 55 to 110 kPa	8 to 16 psig 55 to 110 kPa
Low Side Pressure (cut-out)	1 to 4 psig 7 to 28 kPa	1 to 4 psig 7 to 28 kPa
High Side Pressure (Last 1/3 of cycle)	110 to 120 psig 758 to 827 kPa	150 to 175 psig 1034 to 1207 kPa
Wattage (Last 1/3 of cycle)	140 to 185	140 to 185
Amps (Running)	1.1 to 1.6	1.1 to 1.6
Base Voltage	115 VAC (127 VAC Max)	115 VAC (127 VAC Max)

DEFROST SPECIFICATIONS				
Cabinet Size	Thermostat		Heater	
	Cut-in	Cut-out	Watts	Ohms
18' & 21'	25°F -4°C	47°F 8°C	375	35
14', 15' & 17'	25°F -4°C	47°F 8°C	325	41

CONDENSER FAN MOTOR		
Watts	RPM	Amps
2.3	1100 CW Opposite Shaft	.15 Running

ICE MAKER SPECIFICATIONS		
Electrical	115 VAC (127 VAC Max)	60 Hertz
Thermostat	Opens at 48°F (9°C)	Closes at 15°F (-9°C)
Heater Wattage	165	

ICE MAKER CONNECTOR PLUG CONNECTIONS		
Wire Number	Wire Color	Connects to:
1	Green/Yellow	Ground
2	Yellow	Water Valve
3	Black	Line
4	Lt. Blue	Neutral

SERVICE DATA SHEET

STANDARD - AUTOMATIC DEFROST TOP FREEZER MODELS (R134a) **P/N: 241643300**

IMPORTANT SAFETY NOTICE

The information provided herein is designed to assist qualified repair personnel only. Untrained persons should not attempt to make repairs due to the possibility of electrical shock. Disconnect power cord before servicing.

IMPORTANT

If any green grounding wires are moved during servicing, they must be returned to their original position and properly secured.

CAUTION: All electrical parts and wiring must be shielded from torch flame. Do not allow torch to contact insulation; it will char at 200°F and flash ignite (burn) at 500°F. Excessive heat will distort the plastic liner.

NOTE: Some products come equipped with an Electronic Defrost Control. To initiate defrost, depress the fresh food light switch 5 times in 6 seconds (light bulb must be working). To terminate defrost, depress the fresh food light switch 5 times in 6 seconds.

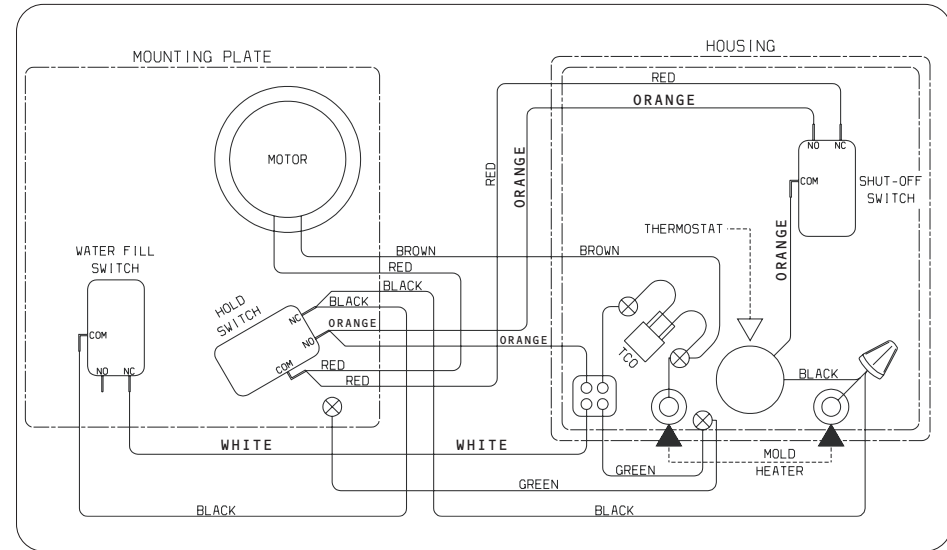

ICE MAKER INFORMATION

Test Cycling

Remove cover by inserting screwdriver in notch at bottom and prying cover from housing. Use screwdriver to rotate motor gear counterclockwise until *Holding Switch* circuit is completed. All components of ice maker should function to complete the cycle.

Water Fill Volume

The water fill adjustment screw will change the fill time. One full turn is equal to 20cc (.68 oz.). The correct fill is 95 to 105cc (3.2 to 3.6 oz.). When a water valve is replaced, the fill volume must be checked.

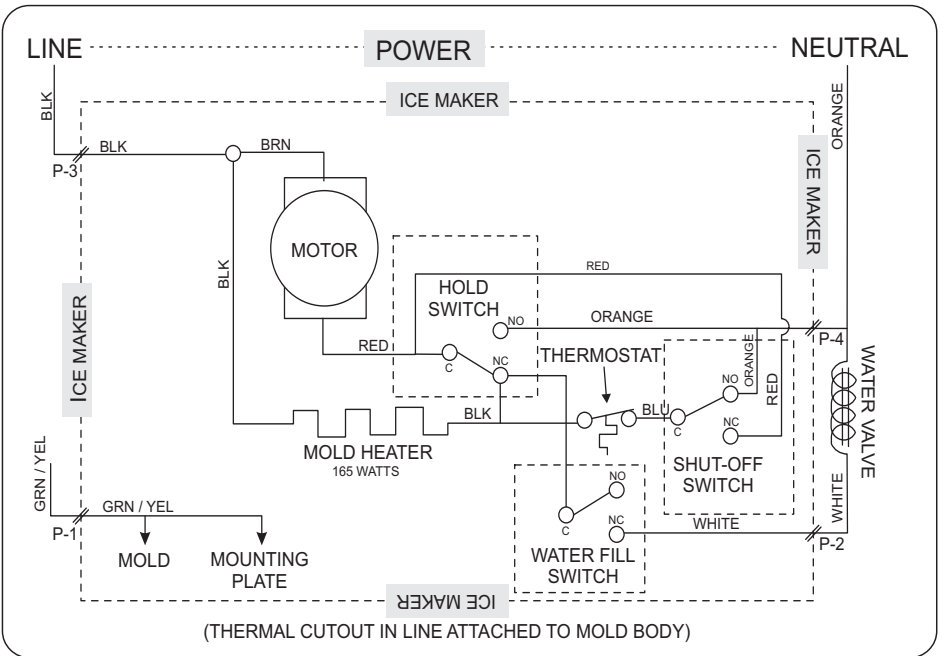

Pictorial Schematic

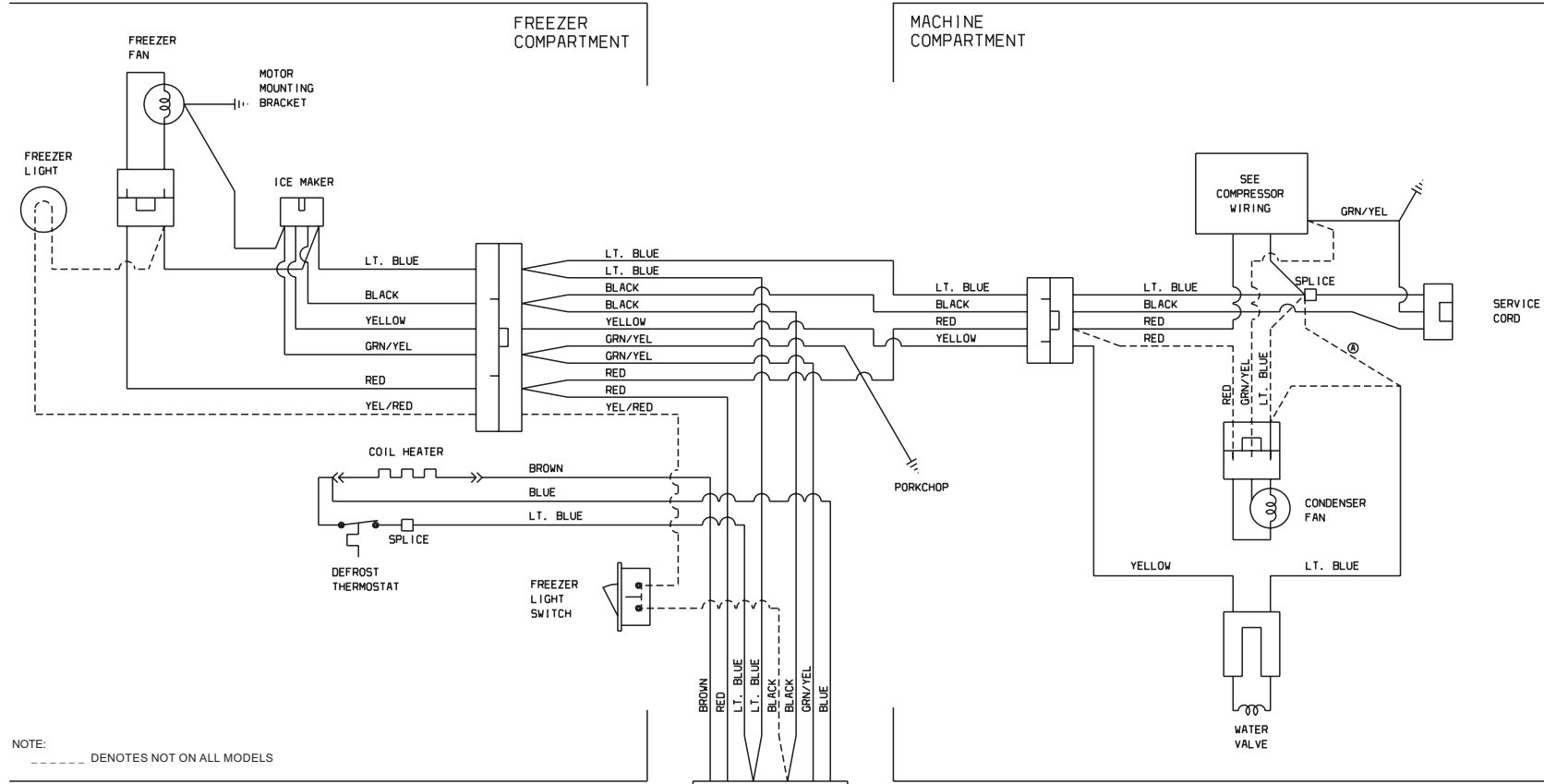

NOTE: - - - - DENOTES NOT ON ALL MODELS

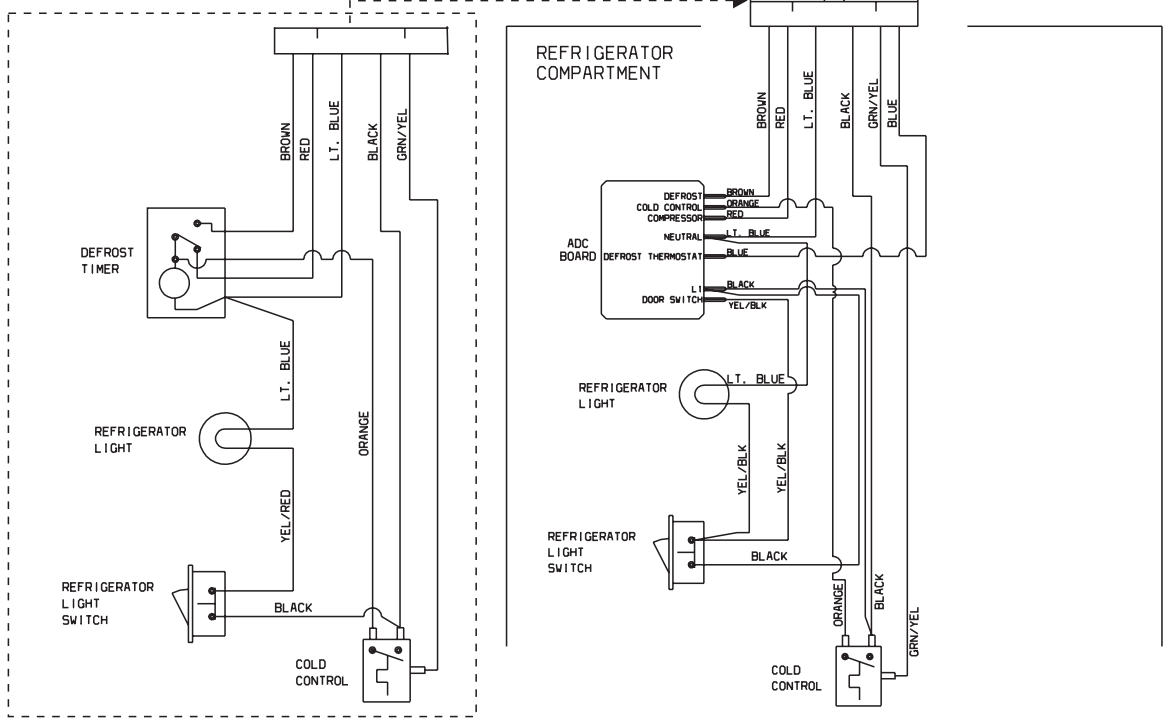

COMPRESSOR WIRING

Induction Run Compressor with Relay

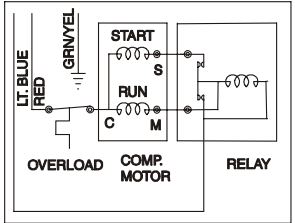

P.T.C. STARTER WITH RUN CAPACITOR

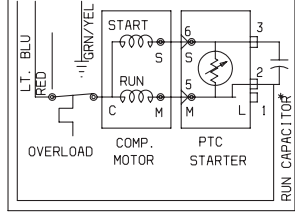

* CAPACITOR IS ONLY USED WITH SOME P.T.C. MODELS.

Ladder Schematic

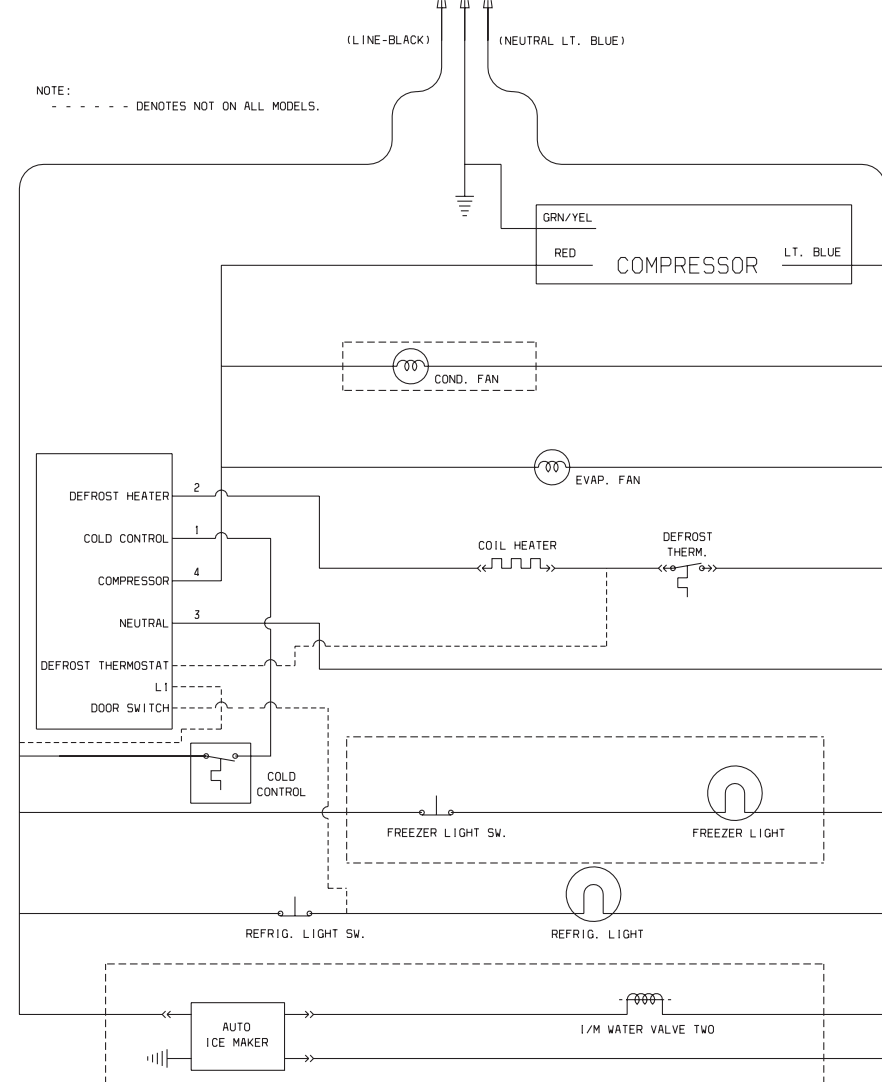

NOTE: - - - - DENOTES NOT ON ALL MODELS.

SERVICE PARTS	15 & 17 CUBIC FOOT			18 CUBIC FOOT			21 CUBIC FOOT	
	STATIC	DYNAMIC	E-STAR	STATIC	DYNAMIC	E-STAR	DYNAMIC	E-STAR
Compressor / Kit *	240550915	240550915	5303918299	240550915	240550915	5303918299	240550915	5303918299
Starter/PTC/TSD *	N/A	N/A	241527802	N/A	N/A	241527802	N/A	241527802
Run Capacitor *	N/A	N/A	218909915	N/A	N/A	218909915	N/A	218909915
Relay	5304433579	5304433579	N/A	5304433579	5304433579	N/A	5304433579	N/A
Overload	5304433578	5304433578	N/A	5304433578	5304433578	N/A	5304433578	N/A
Temperature Control	5304421256	5304421256	5304421256	5304421256	5304421256	5304421256	5304421256	5304421256
Timer (if applicable)	215846606	215846606	215846606	215846606	215846606	215846606	215846606	215846606
ADC (if applicable)	N/A	N/A	N/A	N/A	N/A	N/A	N/A	N/A
Defrost Heater Kit	5303918203	5303918203	5303918203	5303918208	5303918208	5303918208	5303918247	5303918247
Defrost Thermostat Kit	5303918202	5303918202	5303918202	5303918202	5303918202	5303918202	5303918202	5303918202
Evaporator Fan Motor	240369701	240369701	240369701	240369701	240369701	240369701	240369701	240369701
Condenser Fan Motor	N/A	240523601	240523601	N/A	240523601	240523601	240334001	240334001

* Typical compressor kit includes compressor, electrical components, and filter-drier

PERFORMANCE DATA NO LOAD AND NO DOOR OPENINGS AT MID-POINT CONTROL SETTING		
Capacitor Run or Induction Run	65°F (18°C) Ambient	90°F (32°C) Ambient
Operating Time	25 to 35%	45 to 55%
Freezer Temperature	2° to 8°F -17° to -13°C	0° to 5°F -18° to -15°C
Refrigerature Temperature	35° to 40°F 2° to 4°C	35° to 40°F 2° to 4°C
Low Side Pressure (cut-in)	8 to 16 psig 55 to 110 kPa	8 to 16 psig 55 to 110 kPa
Low Side Pressure (cut-out)	1 to 4 psig 7 to 28 kPa	1 to 4 psig 7 to 28 kPa
High Side Pressure (Last 1/3 of cycle)	110 to 120 psig 758 to 827 kPa	150 to 175 psig 1034 to 1207 kPa
Wattage (Last 1/3 of cycle)	140 to 185	140 to 185
Amps (Running)	1.1 to 1.6	1.1 to 1.6
Base Voltage	115 VAC (127 VAC Max)	115 VAC (127 VAC Max)

DEFROST SPECIFICATIONS				
Cabinet Size	Thermostat		Heater	
	Cut-in	Cut-out	Watts	Ohms
18' & 21'	25°F -4°C	47°F 8°C	375	35
14', 15' & 17'	25°F -4°C	47°F 8°C	325	41

Mechanical Timer - Defrost 30 Minutes Every 10 Hours of Compressor Run Time
Electronic Timer (ADC) Defrost Up To 24 Minutes Every 6 - 72 Hours of Compressor Run Time

CONDENSER FAN MOTOR		
Watts	RPM	Amps
2.3	1100 CW Opposite Shaft	.15 Running

ICE MAKER SPECIFICATIONS		
Electrical	115 VAC (127 VAC Max)	60 Hertz
Thermostat	Opens at 48°F (9°C)	Closes at 15°F (-9°C)
Heater Wattage	165	

ICE MAKER CONNECTOR PLUG CONNECTIONS		
Wire Number	Wire Color	Connects to:
1	Green/Yellow	Ground
2	Yellow	Water Valve
3	Black	Line
4	Lt. Blue	Neutral

SERVICE DATA SHEET

STANDARD - AUTOMATIC DEFROST TOP FREEZER MODELS (R134a) | P/N: 241643400

IMPORTANT SAFETY NOTICE

The information provided herein is designed to assist qualified repair personnel only. Untrained persons should not attempt to make repairs due to the possibility of electrical shock. Disconnect power cord before servicing.

IMPORTANT

If any green grounding wires are moved during servicing, they must be returned to their original position and properly secured.

CAUTION: All electrical parts and wiring must be shielded from torch flame. Do not allow torch to contact insulation; it will char at 200°F and flash ignite (burn) at 500°F. Excessive heat will distort the plastic liner.

NOTE: Some products come equipped with an Electronic Defrost Control. To initiate defrost, depress the fresh food light switch 5 times in 6 seconds (light bulb must be working). To terminate defrost, depress the fresh food light switch 5 times in 6 seconds.

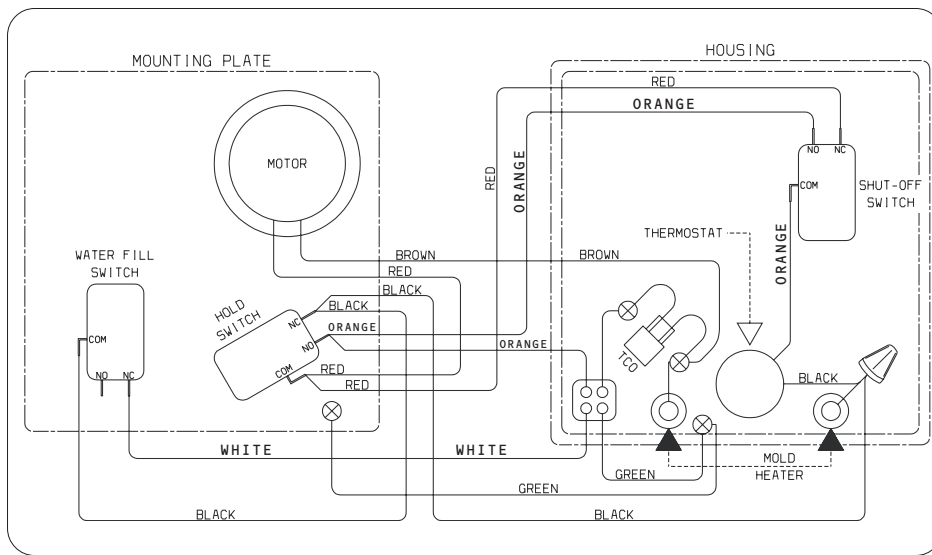

ICE MAKER INFORMATION

Test Cycling

Remove cover by inserting screwdriver in notch at bottom and prying cover from housing. Use screwdriver to rotate motor gear counterclockwise until *Holding Switch* circuit is completed. All components of ice maker should function to complete the cycle.

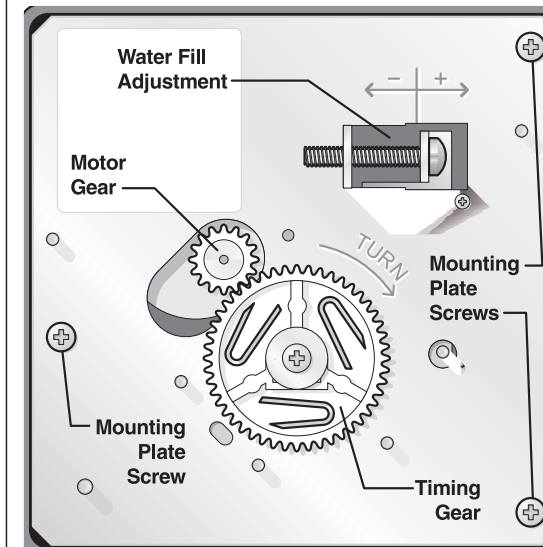

Water Fill Volume

The water fill adjustment screw will change the fill time. One full turn is equal to 20cc (.68 oz.). The correct fill is 95 to 105cc (3.2 to 3.6 oz.). When a water valve is replaced, the fill volume must be checked.

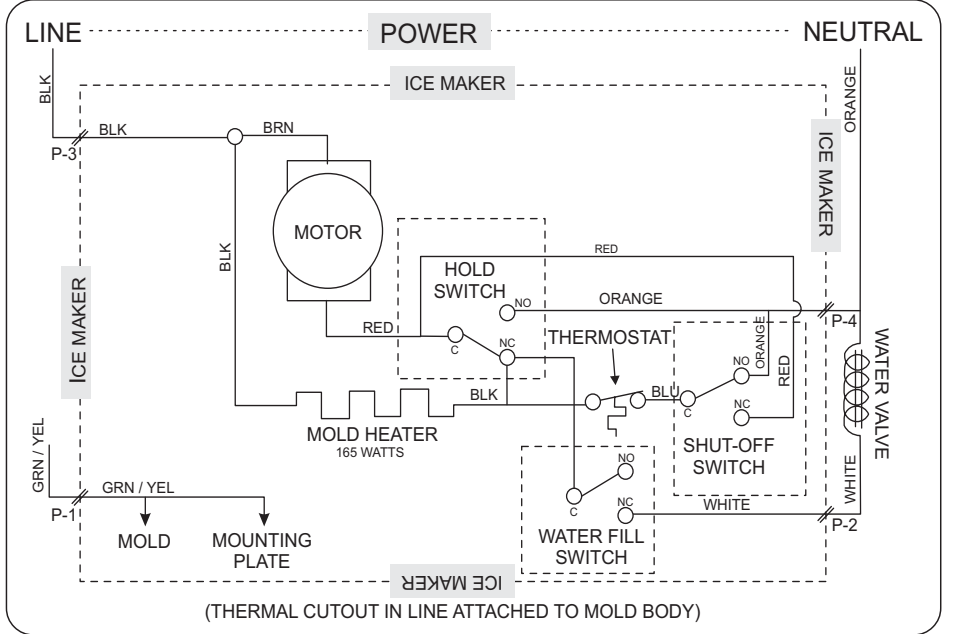

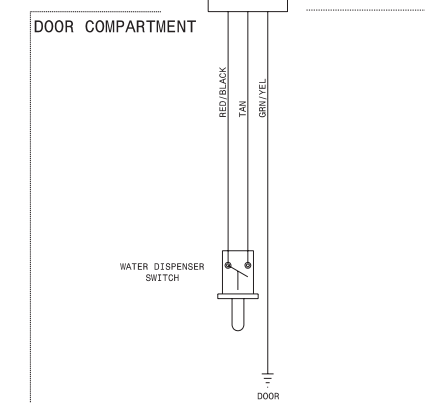
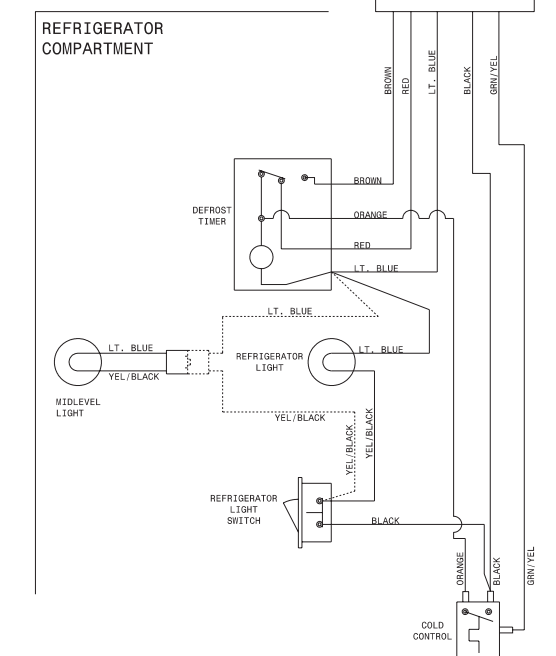
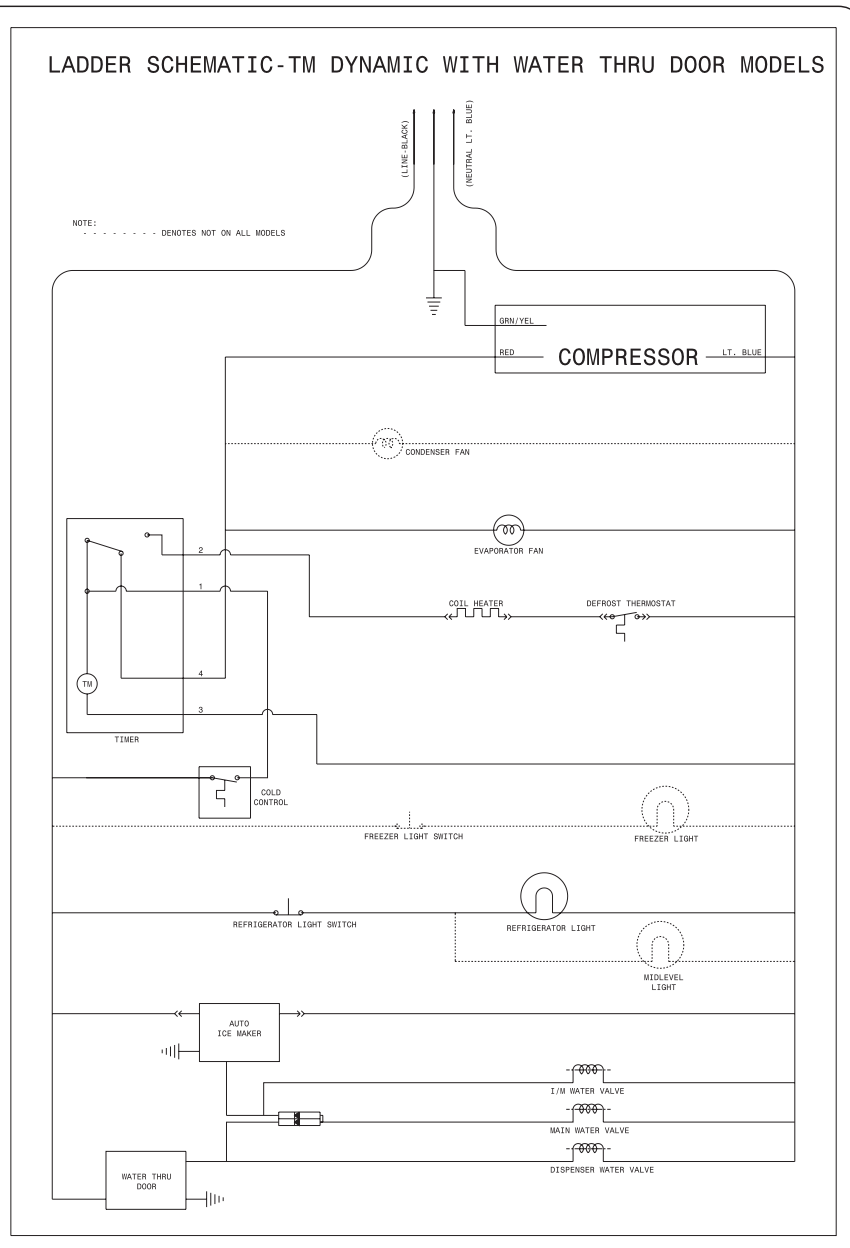
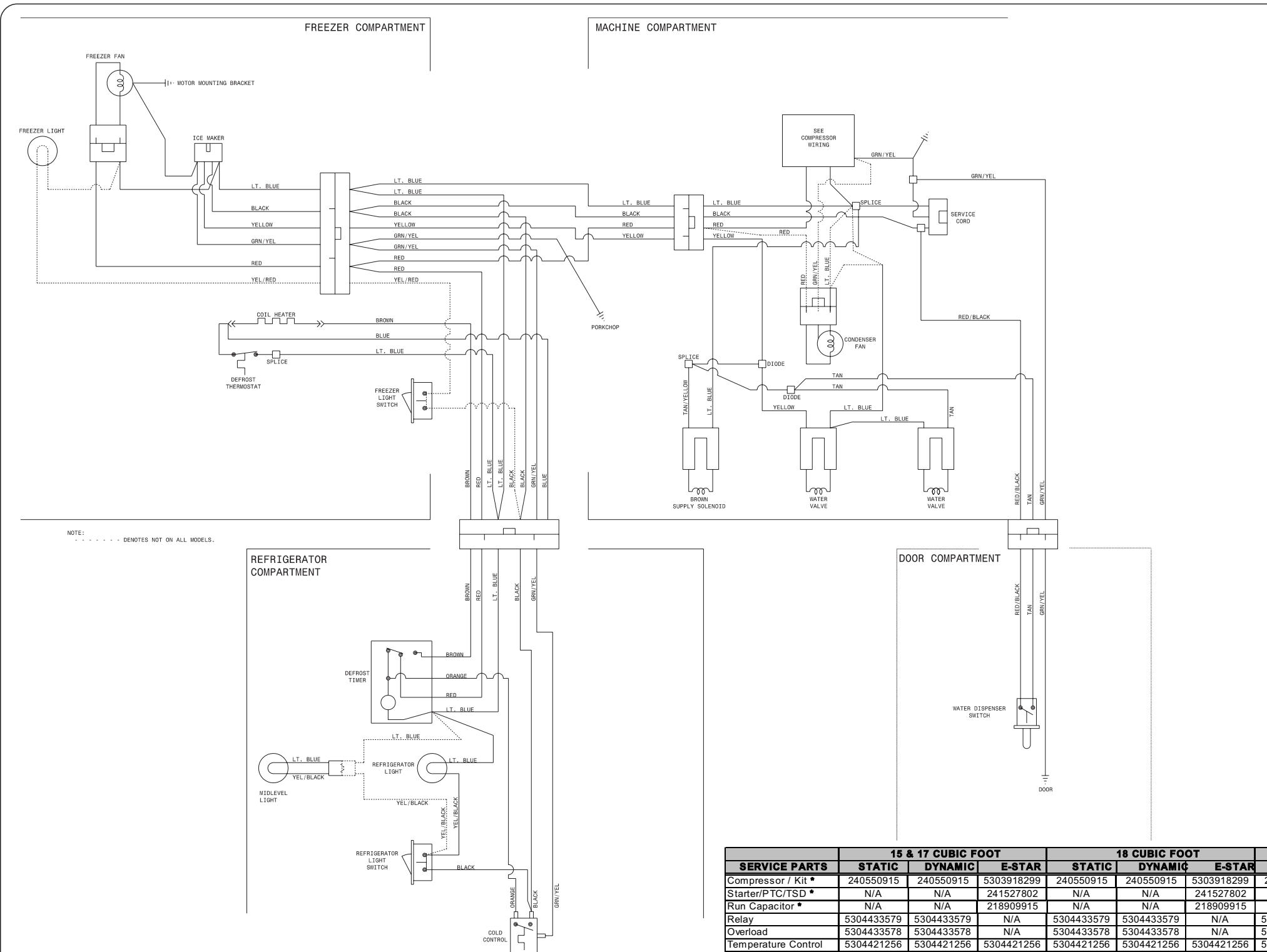

SERVICE PARTS	15 & 17 CUBIC FOOT			18 CUBIC FOOT			21 CUBIC FOOT	
	STATIC	DYNAMIC	E-STAR	STATIC	DYNAMIC	E-STAR	DYNAMIC	E-STAR
Compressor / Kit *	240550915	240550915	5303918299	240550915	240550915	5303918299	240550915	5303918299
Starter/PTC/TSD *	N/A	N/A	241527802	N/A	N/A	241527802	N/A	241527802
Run Capacitor *	N/A	N/A	218909915	N/A	N/A	218909915	N/A	218909915
Relay	5304433579	5304433579	N/A	5304433579	5304433579	N/A	5304433579	N/A
Overload	5304433578	5304433578	N/A	5304433578	5304433578	N/A	5304433578	N/A
Temperature Control	5304421256	5304421256	5304421256	5304421256	5304421256	5304421256	5304421256	5304421256
Timer (if applicable)	215846606	215846606	215846606	215846606	215846606	215846606	215846606	215846606
ADC (if applicable)	N/A	N/A	N/A	N/A	N/A	N/A	N/A	N/A
Defrost Heater Kit	5303918203	5303918203	5303918203	5303918208	5303918208	5303918208	5303918247	5303918247
Defrost Thermostat Kit	5303918202	5303918202	5303918202	5303918202	5303918202	5303918202	5303918202	5303918202
Evaporator Fan Motor	240369701	240369701	240369701	240369701	240369701	240369701	240369701	240369701
Condenser Fan Motor	N/A	240523601	240523601	N/A	240523601	240523601	240334001	240334001

* Typical compressor kit includes compressor, electrical components, and filter-drier

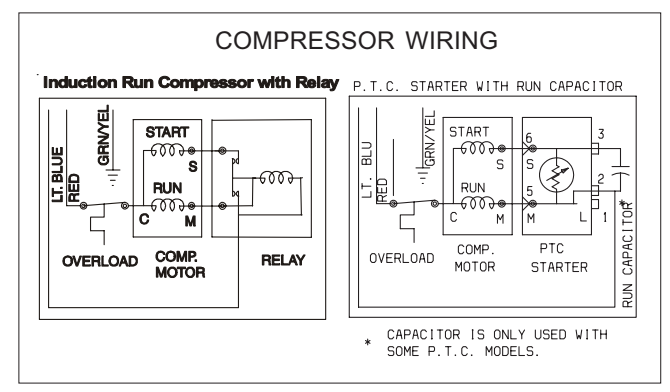

3 Ways To Contact Us!
¡3 formas de contactar nos!
3 façons de nous contacter!

USA, EE.UU., É.-U.,
1-800-944-9044

CANADA, CANADÁ
1-800-265-8352

Or, O, Ou

USA, EE.UU., É.-U.

Electrolux Major Appliances North America,
a division of Electrolux Home Products, Inc.
P.O. Box 212378
Augusta, GA 30917

CANADA, CANADÁ

Electrolux Major Appliances North America,
a division of Electrolux Home Products, Inc.
5855 Terry Fox Way
Mississauga, Ontario, Canada
L5V 3E4

Or, O, Ou

Visit Frigidaire's Web Site at:
Visite la página de Frigidaire en Internet:
Visitez le site Internet de Frigidaire au:

<http://www/frigidaire.com>

© 2005 Electrolux Major Appliances North America,
a division of Electrolux Home Products, Inc.

 **The Electrolux Group.** *The world's No. 1 choice.*

The Electrolux Group is the world's largest producer of powered appliances for kitchen, cleaning and outdoor use combined. More than 55 million Electrolux Group products (such as refrigerators, cookers, washing machines, vacuum cleaners, chain saws and lawn mowers) are sold each year to a value of approximately USD 14 billion in more than 150 countries around the world.

PRINTED IN USA