

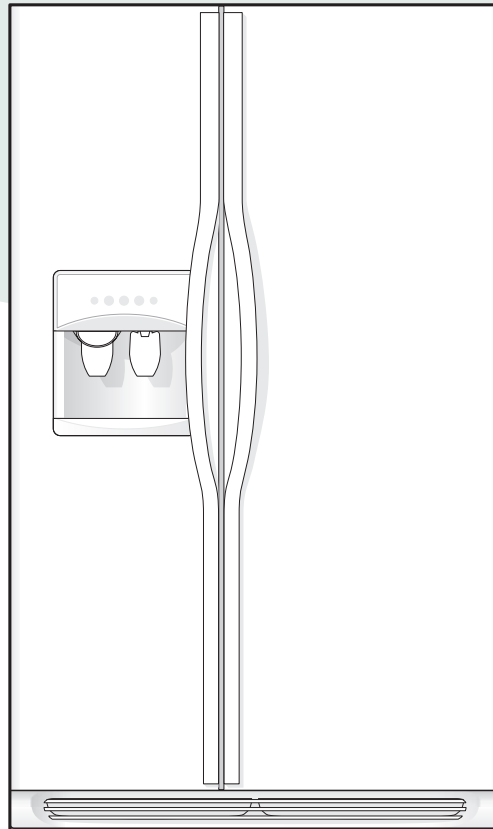

ELECTROLUX HOME PRODUCTS NORTH AMERICA

Service Manual

Side by Side Refrigerator



Frigidaire
Built for Generations

Gibson

Backed by the Platinum Advantage™ Warranty.
Built to Deserve it.

TAPPAN
For The Love Of Cooking™



White-Westinghouse
There's Extra Value In Everything We Do.

Kelvinator
Sensible, Dependable, Affordable.

SAFE SERVICING PRACTICES - ALL APPLIANCES

To avoid personal injury and/or property damage, it is important that **Safe Servicing Practices** be observed. The following are some limited examples of safe practices:

1. **DO NOT** attempt a product repair if you have any doubts as to your ability to complete it in a safe and satisfactory manner.
2. Before servicing or moving an appliance:
 - Remove the power cord from the electrical outlet, trip the circuit breaker to the OFF position, or remove the fuse.
 - Turn off the gas supply.
 - Turn off the water supply.
3. Never interfere with the proper operation of any safety device.
4. **USE ONLY REPLACEMENT PARTS CATALOGED FOR THIS APPLIANCE. SUBSTITUTIONS MAY DEFEAT COMPLIANCE WITH SAFETY STANDARDS SET FOR HOME APPLIANCES.**
5. **GROUNDING:** The standard color coding for safety ground wires is **GREEN**, or **GREEN** with **YELLOW STRIPES**. Ground leads are not to be used as current carrying conductors. It is **EXTREMELY** important that the service technician reestablish all safety grounds prior to completion of service. Failure to do so will create a hazard.
6. Prior to returning the product to service, ensure that:
 - All electrical connections are correct and secure
 - All electrical leads are properly dressed and secured away from sharp edges, high-temperature components, and moving parts
 - All non-insulated electrical terminals, connectors, heaters, etc. are adequately spaced away from all metal parts and panels
 - All safety grounds (both internal and external) are correctly and securely connected
 - All panels are properly and securely reassembled

ATTENTION!!!

This service manual is intended for use by persons having electrical and mechanical training and a level of knowledge of these subjects generally considered acceptable in the appliance repair trade. Electrolux Home Products cannot be responsible, nor assume any liability, for injury or damage of any kind arising from the use of this manual.

TABLE OF CONTENTS

SAFE SERVICING PRACTICES ARE ON THE BACK OF THE FRONT COVER

SECTION A - INSTALLATION INSTRUCTIONS

Uncrating	6
Electrical Information	6
Door Removal	7

SECTION B - REFRIGERATOR CABINET

Basic Construction	9
Cabinet Doors and Gaskets	9
Front Rollers BB	9
Cabinet Touch-Up Procedure	10

SECTION C - ELECTRICAL COMPONENTS

Electrical Grounding	11
Compressor Electrical Components and Circuits for Standard Compressor	11
Solid State Relay	11
To Check/Replace Relay	11
Overload Protector	11
To Check/Replace Overload Protector	11
To Check/Replace Run Capacitor	12
Compressor Start Circuit	12
Compressor Run Circuit	12
Compressor Operating Characteristics	12
Compressor Electrical Check	13
Perimeter and Mullion Hot Tube	13
Evaporator Fan & Motor Assembly	13
To Remove Evaporator Fan Motor	13
Defrost Thermostat	14
To Test Defrost Thermostat	14
To Remove Defrost Thermostat	14
Defrost Heater	15
To Remove Defrost Heater	15
Electrical Mechanical Control System	16
Description	16
Freezer Control	16
Food Compartment Control	17
Air Damper Control	18
Defrost Control	20
System Diagnostics	21
Electronic Control System	29
Start Up Test	29
Discription	30
Alarms and Signals	31
Show Room Settings	31
Change Between Fahrenheit and Centigrade	31
Glass Touch Panel Interface "A"	31
Operation	32
Setting Cooling Temperatures (Two Position Control)	32
Setting Cooling Temperatures (One Position Control)	33
Wiring Schematic	34

Service Diagnostics	37
Manual Defrost	38
Damper	38

SECTION D - AIR CIRCULATION

Principles of Automatic Defrost Operation	39
Air Circulation Patterns	39

SECTION E - REFRIGERATION SYSTEM

Definitions	40
Recovery	40
Recycling	40
Reclaim	40
Safety Warnings	40
Compressor Testing	40
Charging Sealed Systems	40
Soldering	41
Basic Components	41
Perimeter Hot Tube	41
Refrigerant Cycle	41
Low or High Side Leak or Undercharge	41
Testing for Refrigerant Leaks	42
Checking for Internal (Hot Tube) Leaks	42
Compressor Replacement	42
To Flush The System	42
To Use Dry Nitrogen To Flush The System	43
To Use Refrigerant To Flush The System	43
Installing a New Compressor	43
Evaporator Replacement	44
Heat Exchanger Replacement	46
Perimeter Hot Tube Repair Kit	47
Condenser Replacement	49
Filter-Drier Installation	49
Evacuating & Recharging	49
Equipment Needed for Evacuation & Recharging	50
Installing Evacuation & Recharging Equipment	50
Evacuating System	50
Charging The System	50
Final Leak Test	51
R-134a Service Information	52
Verify Refrigerant Type In The System	52
Dedicated Equipment	52
R-134a Refrigeration Systems	52
Miscibility of R-134a and Ester Oil	52
Water in Refrigeration System	53
Vacuum Pump Maintenance	53
Refrigerant Leaks	54
Leak Detection	54
R-134a Properties	54
HFC-134a, CFC-12 Pressure Temperature Chart	55
R-134a Health & Safety Information	56
Inhalation Toxicity	56
Cardiac Sensitization	56
Spills or Leaks	56
Skin and Eye Contact	56
Combustibility of HFC-134a	57
Leak Testing	57
Bulk Delivery & Storage	57

Filling & Charging Systems	57
Refrigerant Recovery Systems	57
Thermal Decomposition	57

SECTION F - ICE MAKER

Rear Mount Ice Mkaer

Ice Maker for Side by Side Models	58
Front Cover	58
Ice Maker Components	58
Ice Mold	58
Mold Heater	58
Ice Stripper	58
Ice Ejector	58
Water Valve Assembly	58
Thermostat	59
Sensing Arm & Linkage	59
Timing Switches	59
Thermal Cutout (TCO)	59
Timing Cam & Coupler	59
Timing Gear	59
Motor	59
Fill Trough	59
Wiring	59
Installing Water Supply Line to Ice Maker	60
Test Cycling Ice Maker	60
Water Valve Switch - Water Fill Switch	60
Parts Replacement	60
To Replace Front Cover	60
To Replace Fill Trough	60
To Replace Ice Stripper	61
To Replace Motor & Switch Mounting Plate	61
To Replace Ejector Blades	61
To Replace Motor	61
To Replace Water Fill Switch	61
To Replace Hold Switch	62
To Replace Ice Maker Control Arm Shut-Off Switch	62
To Replace Ice Maker Thermostat	62
To Replace Thermal Cut-Out (TCO)	62
To Replace Mold and Heater	62
Fault Diagnosis	63
Complaint - Ice Maker Fails To Start	63
Complaint - Ice Maker Fails To Complete Cycle	63
Complaint - Ice Maker Fails To Stop At End Of Cycle	63
Complaint - Ice Maker Continues To Eject When Container Is Full	63
Complaint - Ice Maker Produces Undersized Ice Cubes	63
Ice Maker Testing Procedures	64
Operating Cycle	64
Operating Cycle Illustrations - Manual Cycle	64
Operating Cycle Illustrations - Electrical	64
Operating Cycle Illustrations - Mechanical	F14
Ice Maker Wiring Diagrams (Enlarged View)	F17

SECTION G - ICE & WATER DISPENSER

Ice Dispenser Container & Rail Assembly	75
Dispenser Auger Motor & Solenoid Assembly	75
To Remove Auger Motor	75
To Test Auger Motor	75
To Remove Solenoid Assembly	75
To Test Solenoid Assembly	76
To Remove Lamp Socket & Light Bulb	76
Ice Auger & Crusher Assembly	76
To Replace Crusher Blades	76
Ice & Water Dispenser Assembly	77
Feature Levels	77
To Gain Access to Control Area	78
Fast Freeze - Fast Ice	82
Voltage Testing	84
To Remove Control Board	84

SECTION H - WATER SYSTEM

Water Systems	86
Water Valve	86
Pure Source Water Filters	86
Water Tanks	87
To Test The Water Fill System	89
Diode Replacement	89

SECTION A

INSTALLATION INSTRUCTIONS

UNCRATING

Uncrating instructions are clearly printed on the shipping carton. Under no circumstances should a refrigerator be uncrated until these instructions have been read.

Additional handling and installation information is provided in the "Installation Tips" affixed to the refrigerator door and in the Owner's Guide, located in one of the drawers inside the refrigerator. Pay particular attention to the information regarding hand trucking, leveling and door alignment.

MODEL AND SERIAL NUMBER

Model and Serial Numbers are found on the Serial Plate located on the ceiling of the refrigerator compartment, just behind the compartment light. Or on the right side at the top (See Figure A1)

AIR CIRCULATION

Proper air circulation must be maintained for efficient refrigerator operation. Refer to the Owner's Guide for recommended clearances. Install the refrigerator out of direct sunlight and away from the range, dishwasher, or other heat sources.

CAUTION: Do not install the refrigerator where the temperature will drop below 55°F (13°C), or rise above 110°F (43°C) because the compressor will not be able to maintain proper temperatures.

Allow an extra 3/8" on the top and sides, and 1" from the back for ease of installation, proper air circulation, and plumbing and electrical connections. If the hinge side of the unit is placed against a wall, allow a 1/2" minimum between hinges and wall to permit proper door swing.

NOTE: Do not block the toe grille on the lower front of the refrigerator. Sufficient air circulation is essential for proper operation of the refrigerator.

ELECTRICAL INFORMATION

The refrigerator must be plugged into its own 115 Volt, 60 Hz, AC only electrical outlet. The circuit should be protected by a 15 or 20 Amp circuit breaker or time delay type fuse.

NOTE: If voltage varies by ±10% of 115 volts, performance of the refrigerator may be affected. Operating the refrigerator with insufficient power can damage the compressor.

The refrigerator power cord is equipped with a three prong grounding plug. It must be plugged directly into a properly grounded three prong receptacle. The receptacle must be installed in accordance with local codes and ordinances. **Do not use an extension cord or an adapter plug.**

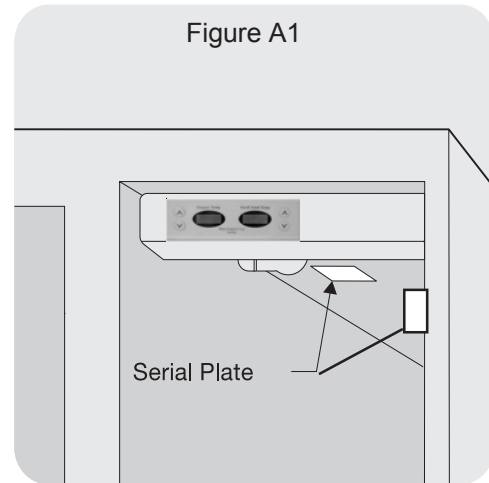

LEVELING

The refrigerator must be leveled with all bottom corners resting firmly on a solid floor. Adjust the front rollers to level the cabinet from side-to-side and front-to-rear. Keep the cabinet as low as possible for stability. Never adjust the cabinet rollers so the front is lower than the rear.

To adjust the front rollers:

1. Open refrigerator and freezer doors.
2. Remove toe grill by pulling it straight out. (See Figure A2.)
3. Adjust rollers by turning each roller adjusting bolt with flat-blade screwdriver, adjustable wrench, 3/8" socket wrench, or 3/8" nutdriver until refrigerator is level and stable. (See Figure A3.)

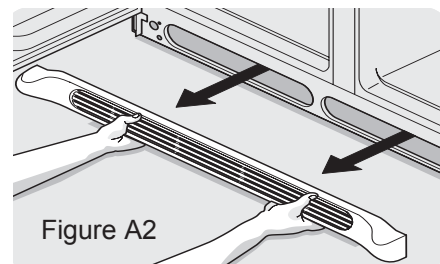

Figure A2

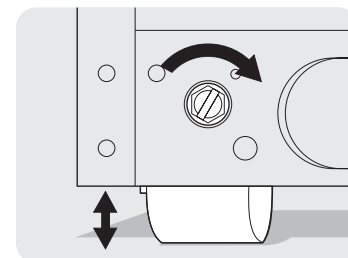

Figure A3

NOTE: Rear rollers are not adjustable.

Door Removal

NOTE: If installation requires the removal of the doors, trace around all hinges with a soft lead pencil for easy relocation.

1. Disconnect electrical supply.
2. Open both doors, then remove toe grille.
3. Close doors.

To Remove Refrigerator Door:

1. Remove top hinge cover screw. Remove cover.

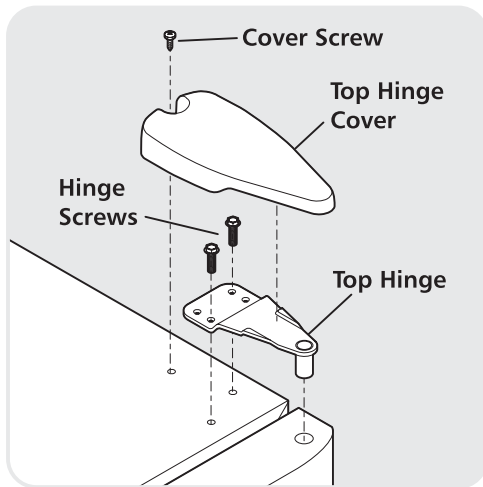

2. Trace around hinge with soft lead pencil. This will make it easier to realign doors when they are replaced.
3. Remove top hinge.
4. Lift refrigerator door off bottom hinge pin. Set door aside.
5. Remove bottom hinge, if necessary.
6. Reverse this procedure to reinstall refrigerator door.

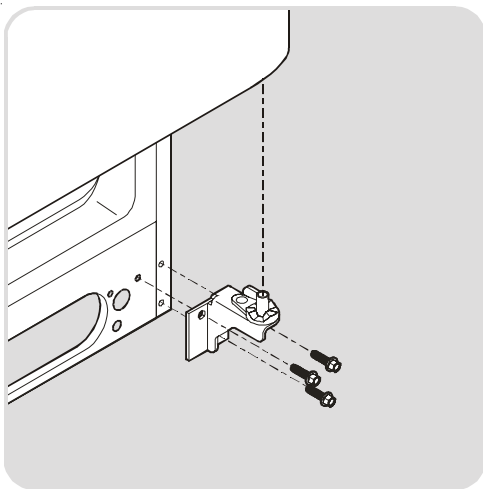

To Remove Freezer Door:

1. Disconnect water line that goes through lower hinge of freezer door at connection located under front of freezer: grip water line firmly in one hand, then with 3/8" wrench or fingers, push in on gray collar to release water connector.

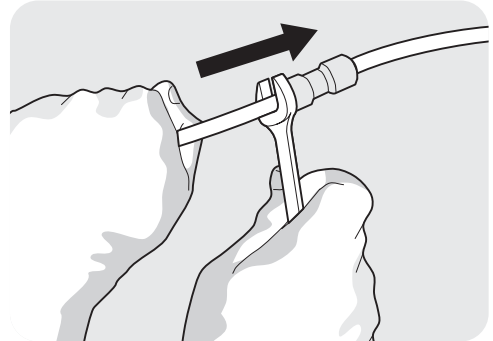

2. Remove top hinge screw on freezer door, then remove cover.

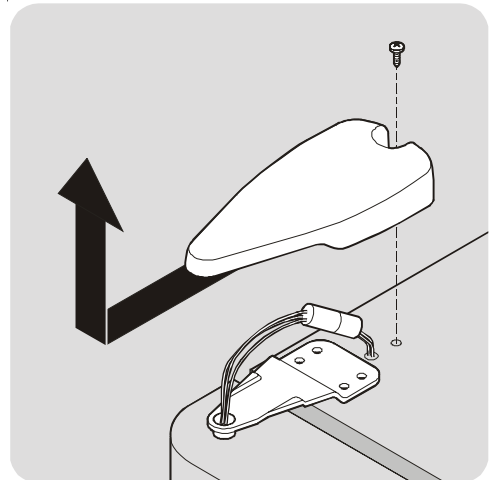

3. Disconnect wiring harness connector plug at top hinge: place your thumbs on flat sides of each connector bending both sides back and forth, then with firm grasp, pull both pieces apart.

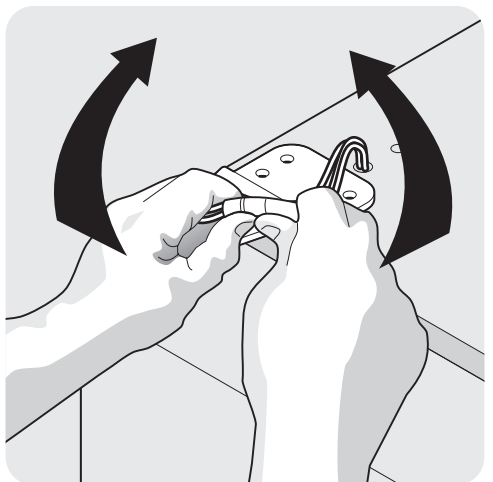

- Trace around hinge with soft lead pencil. This will make it easier to realign doors when they are reinstalled.

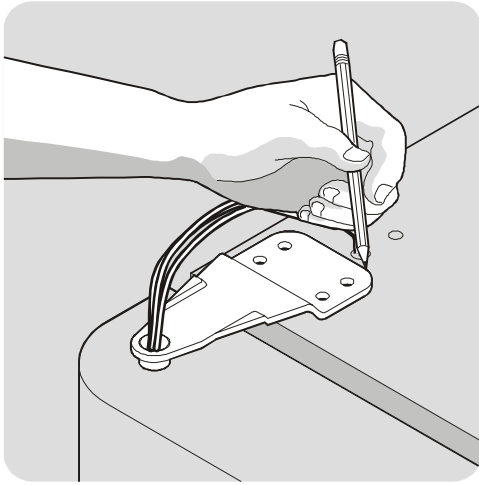

- Remove top hinge, allowing wiring harness to pull through hinge.
- Lift freezer door off bottom hinge pin. Lay door down flat to avoid kinking water line.

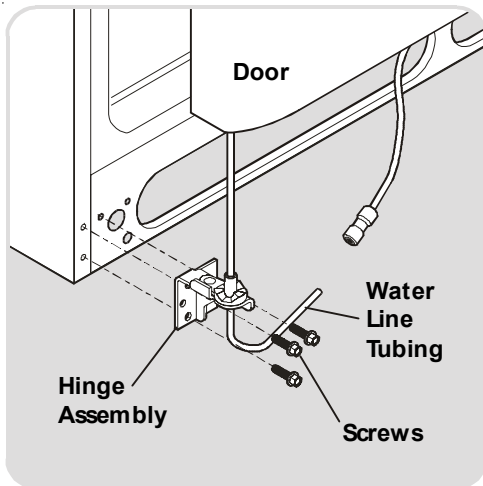

- Remove bottom hinge, if necessary.
- Reverse this procedure to reinstall freezer door.

Door Alignment

Side by Side cabinets, due to their large size, may flex when installed on an uneven floor. To correct alignment, proceed as follows:

- Level refrigerator, front to back and side to side. Open doors and rock refrigerator after each adjustment to relieve cabinet strains.

- After refrigerator is level, close doors and check for proper alignment.
- If refrigerator door is higher than freezer door, raise left corner of cabinet by adjusting roller.

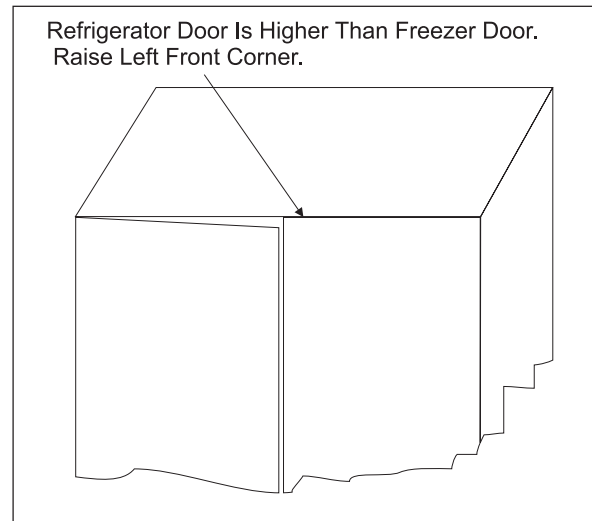

- If refrigerator door is lower than freezer door, raise right corner of cabinet by adjusting roller.

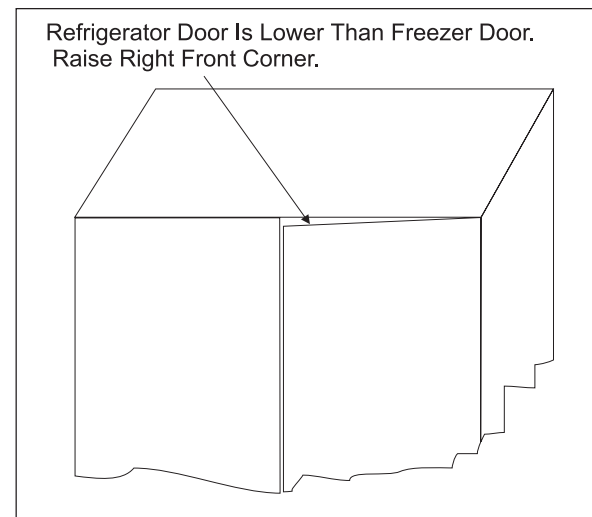

- After cabinet is leveled and doors are properly aligned, ensure refrigerator sets solidly on all four corners.

When both doors have been reinstalled and are correctly aligned, replace toe grille and plug in electrical power cord. Turn both temperature controls to center position. Adjust settings as necessary.

SECTION B - REFRIGERATOR CABINET

BASIC CONSTRUCTION

Counter Depth models have clean back cabinets and/or forced air condensers. The condenser is located under the cabinet bottom. The cabinet wrapper consists of a one-piece top and sides formed of prepainted steel, with an interlocking, snap-in, galvanized steel back panel. A separate steel frame is attached to the cabinet bottom. The compressor compartment houses the compressor, condenser, and fan motor.

All cabinet seams have special sealing materials applied as vapor barriers, prior to installation of the inner liner and foam insulation.

COMPRESSOR MOUNTING

All basic Construction Counter Depth models Side by Sides will have a dynamic condenser and a unitary drain pan assembly that is mounted to the bottom of the refrigerator cabinet just behind the toe grille. (See Figure B1.)

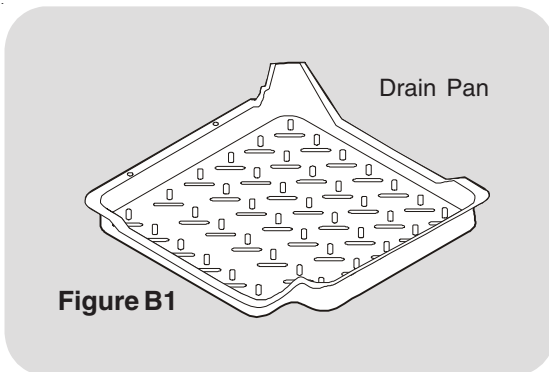

The compressor is mounted on rubber grommets with metal inserts, then bolted to the base using three Hex head, 14-28 shoulder screws. (See Figure B2)

INSULATION AND INNER LINER

The cabinet wrapper and compartment liner are bonded together with a core of "Urethane" foam insulation to form a slim three-ply wall of single-unit construction.

The one piece freezer and the one piece food inner liners are vacuum formed of tough corrosion-proof ABS/HIPS plastic material. The liners are not removable.

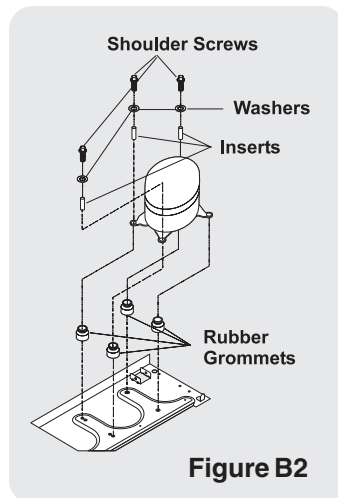

CABINET DOORS AND GASKETS

The exterior door panels are made from one piece of heavy gauge, deep drawn, cold-rolled steel. A wide flange at the periphery is formed integral with the exterior door panel.

Next generation model doors are filled with rigid Urethane foam insulation prior to assembly of the inner panel and door gasket.

The door inner panels are vacuum formed from high strength plastic.

Adjustable Door Bins

Some models have adjustable door bins that can be moved to suit individual needs.

To move door bins:

1. Lift bin straight up.
2. Remove bin.
3. Place bin in desired position.
4. Lower bin onto supports until locked in place.

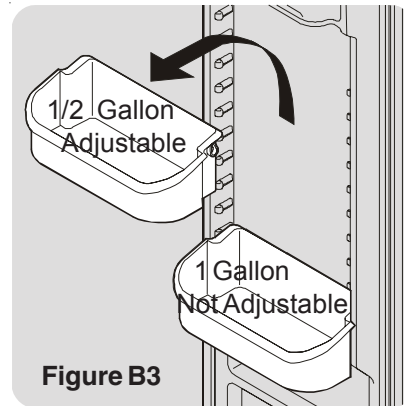

FRONT AND REAR ROLLERS

The front roller is mounted with two screws to the cabinet base and one screw to the front of the cabinet. (See Figure B4) The adjustment screw at the top of the roller is turned clockwise to raise the cabinet, and counter-clockwise to lower the cabinet (See Figure B5). While making adjustments, slightly raise the cabinet to reduce the strain on the roller assembly.

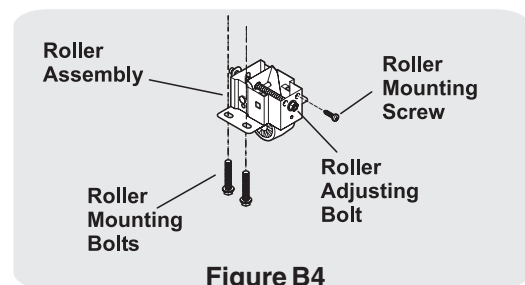
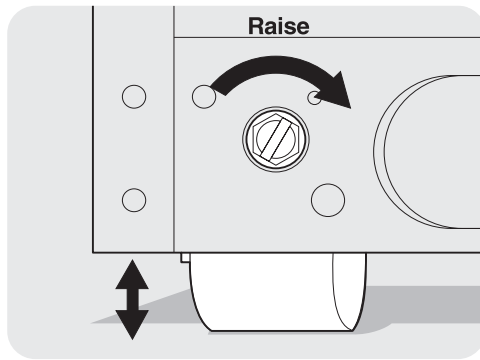

Figure B5



To Remove Front Roller Assembly:

1. Disconnect refrigerator from electrical power.
2. Raise and support cabinet.
3. Remove two bolts securing roller to bottom of refrigerator.
4. Remove one screw securing roller to front of cabinet. Roller should fall free.
5. Reassemble in reverse order.

To Remove Rear Roller: (See Figure B6)

NOTE: The rear roller assembly is mounted to the bottom of the compressor base. Raise and support cabinet before removing rear roller.

1. Disconnect refrigerator from electrical power.
2. Raise and support cabinet.

NOTE: The end of the roller pin that protrudes through the roller has been flared to prevent it from slipping out. You will have to squeeze it back together with a pair of pliers before it will slide out for removal.

3. Squeeze flared end of roller pin together using pair of pliers.
4. Pull roller pin free of roller and compressor base. Roller should fall free. If not, you may have to tap roller lightly with hammer to free it from compressor base.
5. Reassemble in reverse order.

Figure B6

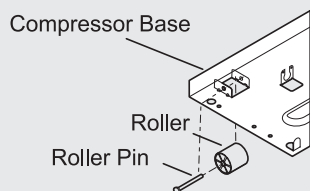

CABINET TOUCH-UP PROCEDURE

Vinyl gaskets are used on all models. Lacquer repairs can be made on all areas of the cabinet except any painted surface that comes in contact with the vinyl gasket. Since prolonged contact of vinyl gaskets with lacquer will soften the lacquer, repairs in these areas should not be attempted.

Lacquer Refinishing

The following steps to touch-up or refinish a acrylic painted cabinet, **except in gasket contact areas**.

1. Sand out spot to be repaired with 360 or 400 wet-or-dry sandpaper. Finish sanding to feather edge with 600 wet-or-dry sandpaper. Wipe area dry. Hand rub with fine rubbing compound (Dupont VZ1090® or equivalent), the area extending at least six inches beyond edges of lacquer repair spot. Wipe compound off and wash area with Naphtha. Dry with clean cloth.
2. Prepare bare metal with Sol-Kleen® cleaner and rust remover. Reduce cleaner with two parts water, and apply with a clean wet rag. Do not touch painted surface with this cleaner. Stubborn or deep seated rust can be removed by applying cleaner with steel wool.

NOTE: Prepare surface of bare metal with Sol-Kleen® regardless if rust is present.

3. Before cleaner dries, wipe surface dry with clean rag.
4. Wipe over surface thoroughly second time with solution of 50-50 alcohol and water. Wipe again with clean dry rags, preferably new cheesecloth.
5. Allow to dry for at least 10 to 15 minutes.
6. Apply primer surfacer, reduced by approximately equal parts of lacquer thinner, to build bare metal area up to surrounding surface. Any imperfections which primer has not filled should be knifed out with lacquer type putty glaze.
7. If no putty glaze is used, allow to dry about 30 minutes and, if necessary, sand out lightly with 360 wet-or-dry sandpaper. If putty glaze is used, allow about three hours before sanding with sandpaper and water. Remove sanding residue thoroughly by wiping with clean rag soaked in naphtha. Wiping surface with tack rag will remove dust and lint.
8. Finish repair with two or more coats of lacquer (reduce approximately one part of lacquer to 1½ parts of thinner). Finally, apply mist coat of lacquer thinner to flow out surface.
9. Patched area should be allowed to dry three or more hours before rubbing with compound or polish.

This procedure also applies to the complete refinishing of the cabinet, except gasket contact areas. All damaged areas should be repaired as outlined in steps 1 through 6 above. The overall surface of the cabinet should be sanded thoroughly and cleaned as outlined in step 7.

The cabinet should be given two or more coats of touch-up lacquer and polished as outlined in steps 8 and 9.

SECTION C - ELECTRICAL COMPONENTS

ELECTRICAL GROUNDING

All refrigerators are equipped with a power supply cord incorporating a three-prong grounding plug and a ground wire which is attached to the refrigerator cabinet for protection against shock hazard. Each electrical component is either cabinet mounted or connected through a ground wire to the cabinet to complete the ground. Certain components, such as defrost timers, may be double insulated and do not require a ground wire.

Ensure the electrical wall receptacle is of the three prong type and is properly grounded in accordance with the National Electrical Code and/or local codes.

COMPRESSOR ELECTRICAL COMPONENTS AND CIRCUITS

The new series of very high efficiency compressor is equipped with all new electrical components consisting of a solid state PTC relay with a thermally operated overload protector, and a run capacitor.

Solid State Relay

The solid state relay has no moving parts. It consists of a PTC resistor mounted in a plastic case with appropriate terminals. PTC (Positive Temperature Coefficient) simply denotes a resistor which increases in resistance as its temperature is increased. The self-heating PTC resistor used in the solid state relay has the unique characteristic of changing from low to very high resistance very abruptly, thus serving as an on-off switch (See Figure C1).

The solid state relay plugs directly onto the compressor start and run terminals. Relay terminals 1, 2, and 5 are connected within the relay, as are terminals 3 and 6.

A run capacitor is connected to relay terminals 2 and 3, so it is connected in parallel with the PTC resistor. One side of the 120 VAC power is connected to relay terminal 1. The other side of line is connected to the overload protector. (See figure C1)

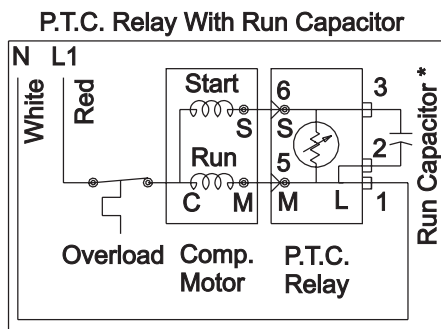

* Capacitor Is Only Used With Some P.T.C. Models.

Figure C1

To Check/Replace Relay

1. Disconnect electrical supply to refrigerator.
2. Remove bale wire holding relay to compressor.
3. Remove relay assembly from compressor.
(See Figure C2)

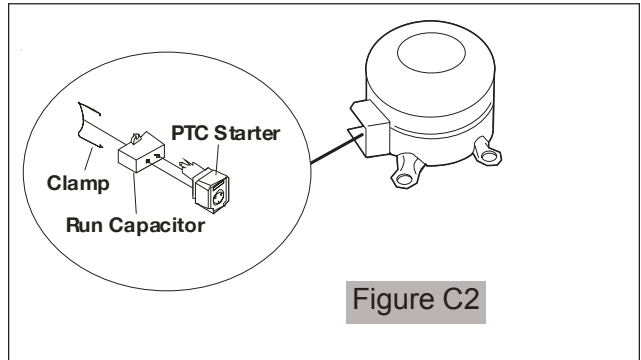

Figure C2

4. Use small, flat-bladed screwdriver to disconnect leads to relay assembly.
5. Use flat headed screwdriver to gently pry capacitor from relay assembly.
6. Use ohmmeter to check resistance between terminals 5 and 6. Resistance should be 3 to 12 ohms, at normal room temperature. Shorted relay will read 0 ohms. Open relay will read very high or infinite resistance.
7. If ohm readings are out of range, replace relay.
8. Reverse this procedure to re-assemble.

NOTE: When replacing leads to the PTC relay, ensure locking tabs snap into terminal.

Overload Protector

The overload protector is completely thermally operated. It will open from excessive heat or current. Unlike prior overloads, the internal bi-metal is not self-heating, and is not a part of the electrical circuit. The overload has a small built-in coil heater that is in series with the compressor start and run windings (See Figure C1).

To Check/Replace The Overload Protector

1. Disconnect electrical supply to refrigerator.
2. Remove bale wire holding relay to compressor.
3. Remove relay assembly from compressor.
4. Use flat headed screwdriver to gently pry capacitor from relay assembly.
5. Use small, flat-bladed screwdriver to disconnect leads to relay assembly. (Note: On some models you will have to remove bale wire and cover, to gain access to relay and overload protector.)
6. Use ohmmeter to check resistance between tab terminal and female pin terminal. Overload protector should have less than 1 ohm of resistance at normal room temperature.

- If ohm readings are out of range, install new Starter/Overload Assembly.

NOTE: The Overload Protector is built into the Starter Overload Assembly.

- Reverse this procedure to re-assemble.

NOTE: When replacing leads to the PTC Relay, ensure the locking tabs snap back into the terminal.

Run Capacitor

The run capacitor has permanently attached terminals which are connected to relay terminals 2 and 3.

NOTE: Some models are not equipped with a Run capacitor

To Check/Replace The Run Capacitor

- Disconnect electrical supply to refrigerator.
- Remove bale wire holding relay to compressor.
- Use small, flat-bladed screwdriver to disconnect leads to relay assembly.
- Use flat-bladed screwdriver and gently pry capacitor from relay assembly.
- Discharge capacitor by shorting across terminals with 500K (1 watt) resistor for one minute.
- Use ohmmeter set on the “**Ohms times 1000**” scale (if available), to check resistance across capacitor wire terminals.
 - The needle should jump towards zero ohms and quickly move back to infinity.
 - If the needle does not move, the capacitor is open.
 - If the needle reads a constant value at or near zero ohms, the capacitor is shorted out.
 - If the needle jumps toward zero and then moves back to constant high resistance (not infinity), the capacitor has a high resistance leak.
- If ohm readings are out of range, replace capacitor.
- Reverse procedures to re-assemble.

Compressor Start Circuit

When the compressor circuit is first energized, the solid state relay has low resistance (3-12 ohms), and both the run and start windings are energized to start the compressor. The run capacitor¹ is being bypassed by the relay, and it has a minor function during compressor starting (See Figure C3).

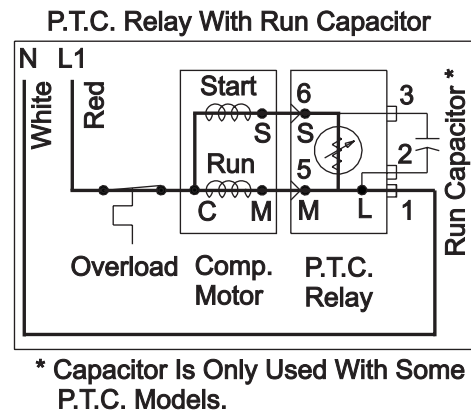

Figure C3

Compressor Run Circuit

When the self-heating solid state relay has reached sufficient temperature, it will abruptly change from low resistance (3-12 ohms) to very high resistance (10-20K ohms) and, in effect, switches off the start windings.

The relay no longer shunts the run capacitor. The run capacitor is now in series with the start windings. The only purpose of the run capacitor is to improve compressor operating efficiency, which it does by correcting the power factor of the compressor motor (See Figure C4).

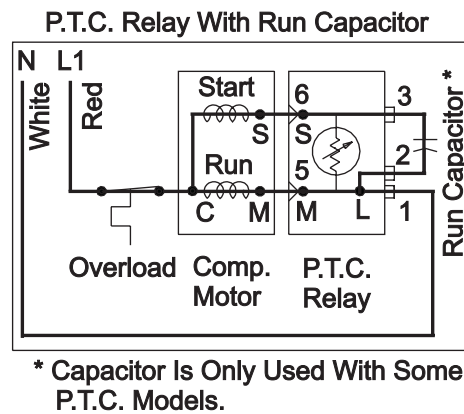

Figure C4

COMPRESSOR OPERATING CHARACTERISTICS

- When the compressor electrical circuit is energized, the start winding current causes the relay to heat and switch off the start winding circuit.

NOTE: The relay will switch off the start winding circuit even though the compressor has not started (as when attempting to re-start after momentary power interruption).

- The overload protector is designed and calibrated to open the compressor electrical circuit with locked rotor run winding current only.

- With an open relay, the compressor will not start since there is little or no current to the start windings. The overload protector will open due to high locked rotor run winding current.
- With a shorted relay or capacitor, the compressor will start, and the overload protector will open.
- With an open or weak capacitor, the compressor will start and run. The compressor, however, will be operating at reduced efficiency of energy usage.

COMPRESSOR ELECTRICAL CHECK

If the compressor will not run, make a voltage check across the power lead terminals on the PTC Relay. (See Figure C4.)

The voltmeter should show line voltage if the thermostat knob is in normal operating position and not in the OFF position. If this check does not show a live circuit, the control thermostat and defrost timer wiring should be checked for loose and/or broken connections.

A control thermostat check can be made by using a piece of wire as a temporary bridge across two thermostat terminals. If the compressor starts and runs with the bridge, the control thermostat is at fault and should be replaced.

If the voltage check shows power supply at the PTC Relay terminals, use a test cord to check the compressor.

If the compressor does not start and run with the test cord, check the line voltage to see if there is more than 10% variation from the rated voltage. If voltage is correct and the compressor will not start and run, replace the compressor.

If the compressor starts and runs with the test cord, replace the PTC Relay.

PERIMETER AND MULLION HOT TUBE

To reduce the possibility of condensation forming on the exterior of the cabinet in high humidity areas, units are equipped with a one piece perimeter and mullion hot tube which is part of the refrigeration system. No electric heaters are used. Refer to the Refrigeration Section for more information.

EVAPORATOR FAN & MOTOR ASSEMBLY

The fan and motor assembly are located behind the freezer compartment air duct directly above the evaporator in the freezer compartment.

The fan is a suction type, pulling air up through the evaporator and blowing it through the refrigerator compartment fan grille.

On current production models, the fan blade is not adjustable and is designed to be pressed onto the motor shaft until it bottoms out against the stop at the front of the fan blade.

To Remove Evaporator Fan Motor

1. Disconnect refrigerator from electrical supply.
2. Remove freezer section bottom shelves and baskets.
3. Remove ice container and rail assembly. The multiconnector at the back of the rail assembly must be disconnected before rail assembly will come free.
4. Loosen the 2 screws holding ice maker to right side of compartment just enough to lift ice maker free. The multiconnector must be disconnected before ice maker will come free from compartment.
5. Remove two rail assembly supports. (two screws on each one).
6. Remove four screws from evaporator cover.
7. Remove five screws on evaporator air duct cover.
8. Disconnect connector and green ground lead connected to evaporator fan motor. Evaporator fan motor assembly can now be pulled free.
9. Remove two screws holding fan motor bracket to shroud.
10. Remove fan blade and slinger washer.
11. Remove two screws holding front and rear motor brackets together. Pull evaporator fan motor free.
12. Reverse procedure to complete repairs.

NOTE: The Slinger washer on the fan motor shaft must be adjusted to within 1/16" to 1/8" from motor to prevent water from entering motor bearing.

NOTE: When replacing the fan blade, press the blade onto the motor shaft until the blade bottoms out on the shaft.

Figure C5



Evaporator Fan Motor Assembly

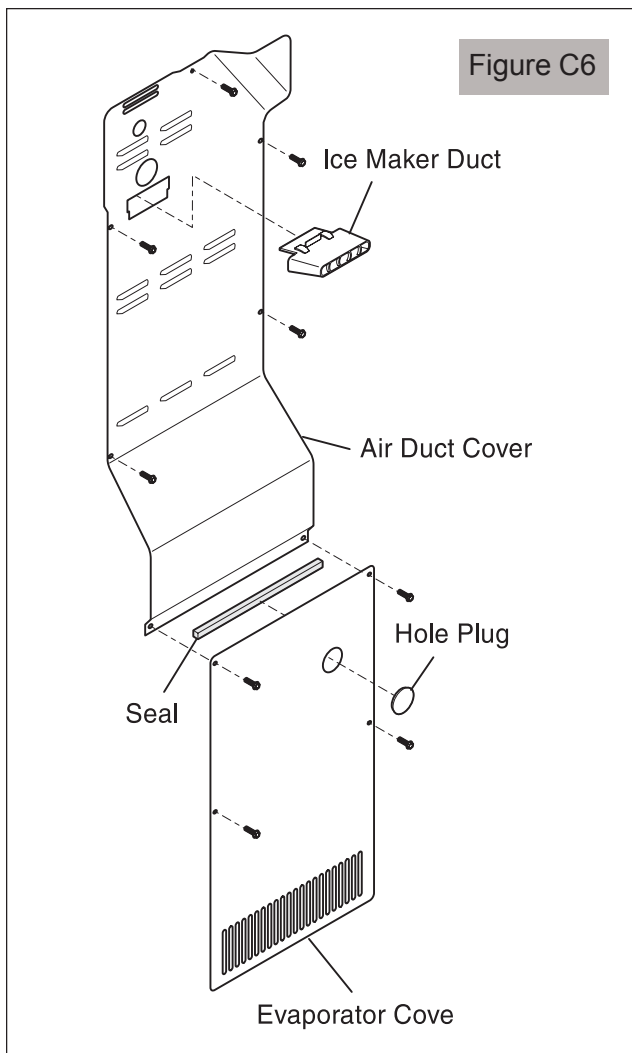

DEFROST THERMOSTAT

The defrost thermostat is a temperature sensing device. Wired in series with the defrost timer and the evaporator defrost heater, it senses the rise in evaporator temperature during a defrost cycle and cycles the defrost heater off after all frost is melted. It is calibrated to permit a defrost cycle only when the temperature is below a preset temperature. The contacts in the defrost thermostat are set to open at 47°F and close at 25°F.

To Test The Defrost Thermostat

1. Measure resistance across two thermostat leads at the connector plug. At room temperature, resistance should be infinity. The contacts are open.
2. Place a couple ice cubes on sides of thermostat. After a few seconds, thermostat should reset.
3. Measure resistance again. This time, reading should be 0. Contacts have closed.
4. If you get resistance readings that differ from this procedure, replace defrost thermostat. Contacts are probably burnt.

To Remove The Defrost Thermostat

1. Disconnect refrigerator from electrical supply.
2. Remove freezer section bottom shelves and baskets.
3. Remove ice container and rail assembly. The multiconnector at the back of the rail assembly must be disconnected before rail assembly will come free.
4. Loosen the 2 screws holding ice maker to right side of compartment just enough to lift ice maker free. The multiconnector must be disconnected before ice maker will come free from compartment.
5. Remove two rail assembly supports. (two screws on each one).
6. Remove four screws from evaporator cover.
7. Remove five screws on evaporator air duct cover.
8. Cut the two leads coming from the thermostat close to the base. You must leave enough wire coming from the connector to allow for splicing the new thermostat in.
9. Remove faulty thermostat.

NOTE: The Defrost Thermostat Replacement Kit comes with a new thermostat, 2 solderless connectors and two pieces of heat shrink to allow for splicing the new thermostat to the connector plug.

10. Crimp the two solderless connectors to the two leads on the new thermostat.
11. Slip the two pieces of heat shrink onto the two leads coming from the connector plug.
12. Crimp the two solderless connectors to the two leads coming from the connector plug.
13. Slip the heat shrink over the solderless connectors and heat that area with a heat gun until the heat shrink is tight around the solderless connectors.
14. Hook the thermostat back on the evaporator near or at the same place it was before.
15. Reverse Steps 1 - 7 to complete repairs.

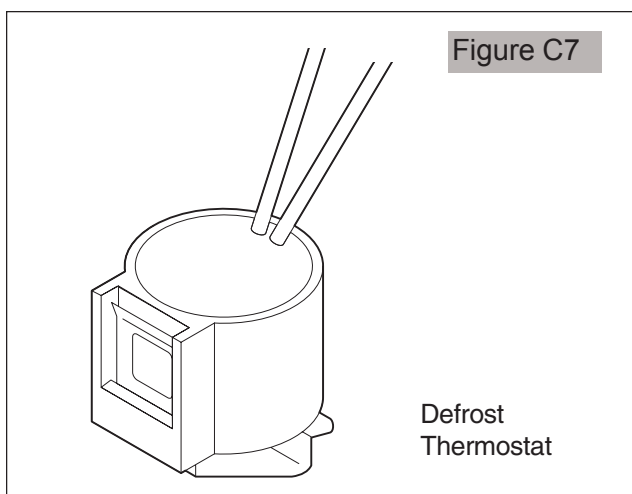

DEFROST HEATER

The defrost heater is a radiant “U” shaped resistance heater, rated at 450 watts. The defrost heater is energized during that period of the cycle when the defrost thermostat contacts are closed.

The length of time the heater is energized depends on the amount of frost accumulation on the evaporator.

How To Remove The Defrost Heater

1. Disconnect refrigerator from electrical supply.
2. Remove freezer section bottom shelves and baskets.
3. Remove ice container and rail assembly. The multiconnector at the back of the rail assembly must be disconnected before rail assembly will come free.
4. Loosen the 2 screws holding ice maker to right side of compartment just enough to lift ice maker free. The multiconnector must be disconnected before ice maker will come free from compartment.
5. Remove two rail assembly supports. (two screws on each one).
6. Remove four screws from evaporator cover.
7. Remove five screws on evaporator air duct cover.
8. Disconnect two leads to defrost heater.

NOTE: This is a good time to test the heater. Check resistance of defrost heater using a multimeter. Resistance should be very close to 30 ohms. Replace defrost heater if resistance readings are out of range.

9. Unclip ground wire hooked to drain trough.
10. Remove screw holding evaporator bracket through drain trough to cabinet.
11. Remove rivet holding bracket to trough and set bracket aside for reuse.
12. Remove screw holding drain trough to cabinet.
13. Lift up and pull evaporator and drain trough out at bottom.

NOTE: Use caution not to damage suction line or cap tube.

14. Slide the drain trough off the evaporator.
15. Remove the retainer clamp from bottom of evaporator holding the heater in place.
16. Grab heater from bottom and pull free of the evaporator. It's very snug so you'll need to use a little force.
17. Replace with new defrost heater.
18. Re-assemble in reverse order.

Figure C8

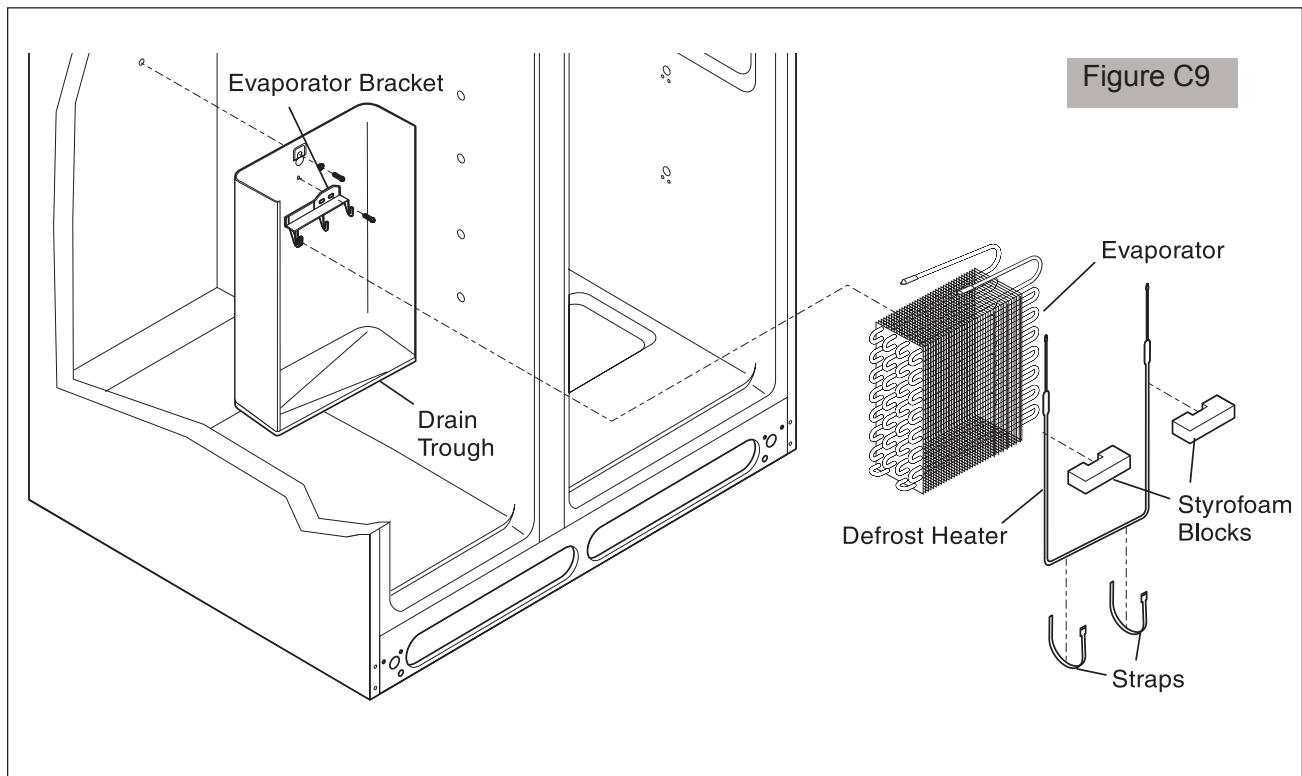
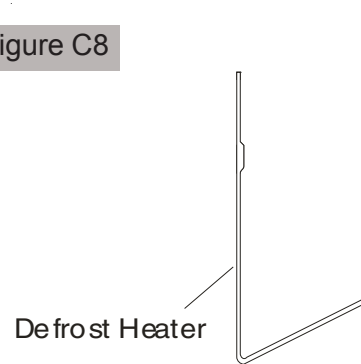

ELECTRICAL MECHANICAL CONTROL SYSTEM

The *Freezer* and *Refrigerator* controls are located in the same housing, mounted in the food compartment along with the light, Damper and Automatic Defrost Control (ADC). See Figure 1.

The 2 housings will separate at the left back of the front housing by sliding the rear housing to the right until the buttons line up with the larger hole in the slots. (See Figure 3.)

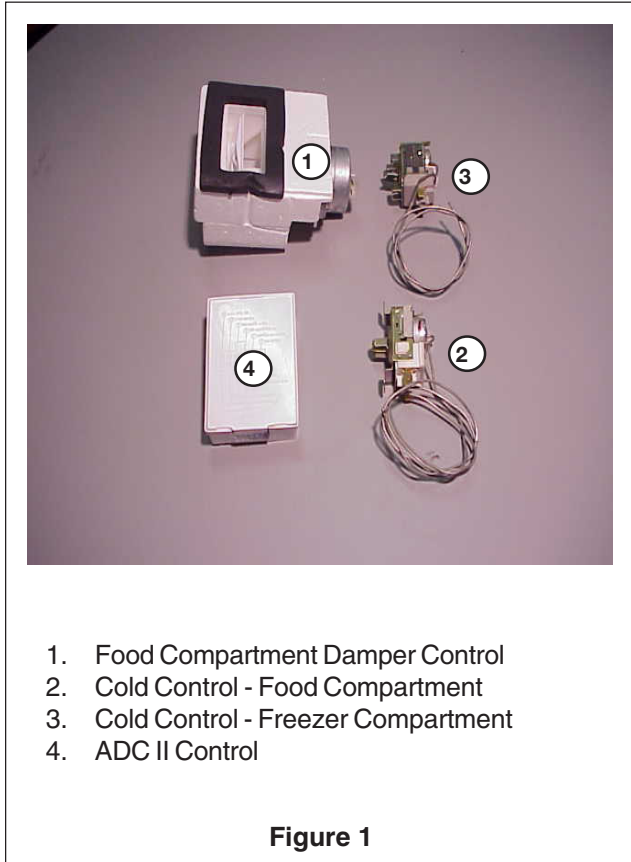

To remove the *Control Housing Assembly*, remove the three screws across the front control box and the two screws located in the rear control box. (See Figure 2.)

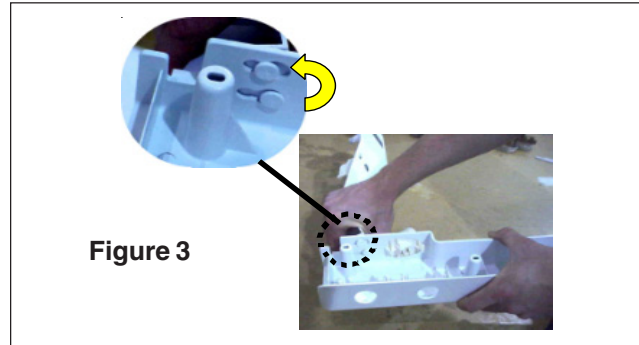
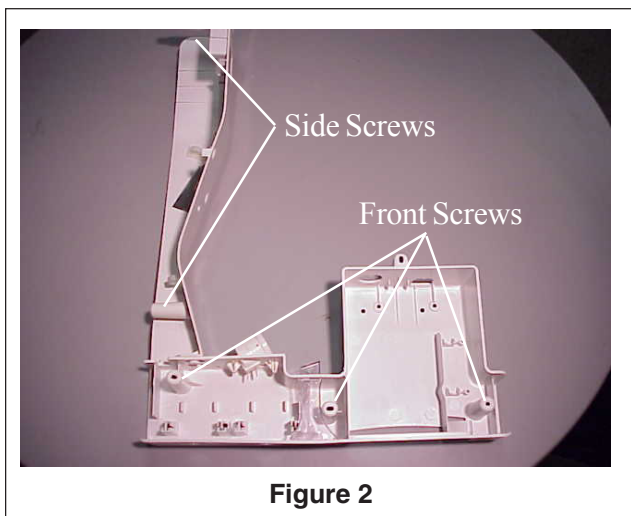

Freezer Compartment Control

The Freezer Control is mounted on the left (as shown in Figure 4) and it controls the cycling of the compressor and fan motors. The cap tube for the control runs along the right side of the rear housing and has a plastic sleeve installed on the last eight inches.

To replace the Freezer Control, remove screws and drop housing. Pull the cap tube for the control from the guide tube under the air inlet at the back of the rear housing. (See figure 4.)

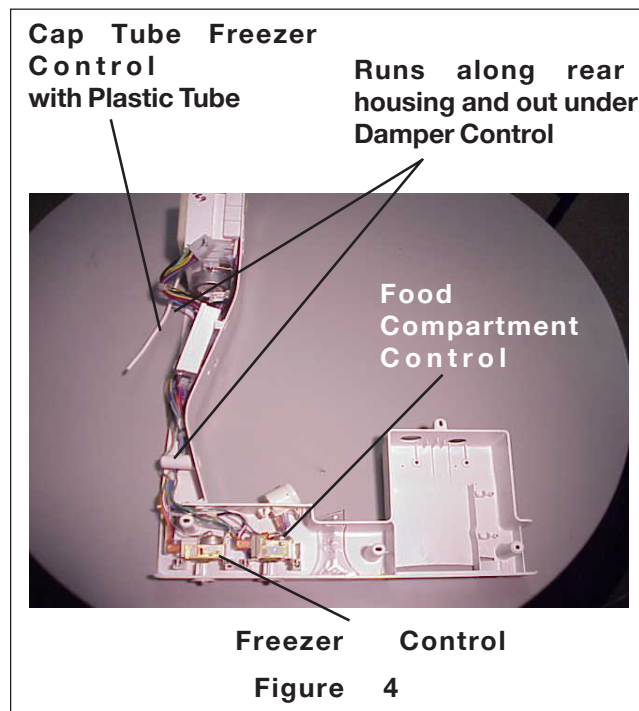

When you install the new Freezer Control, connect wires as shown in Figure 5. The ground wire (green) must be attached as well.

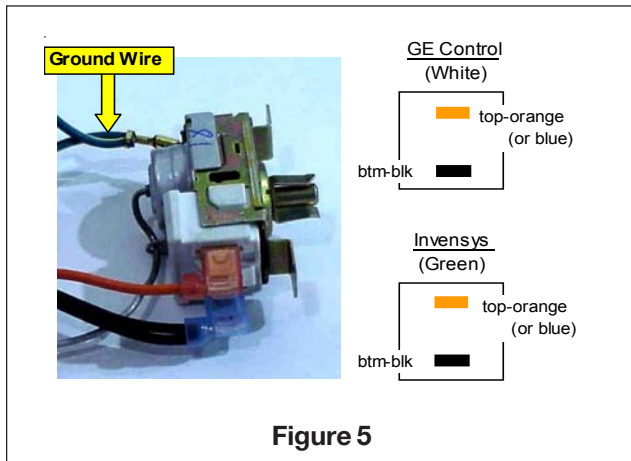

Figure 5

After the wires are connected, snap the control into place and route the wires around the screw boss. (See Figure 6.)

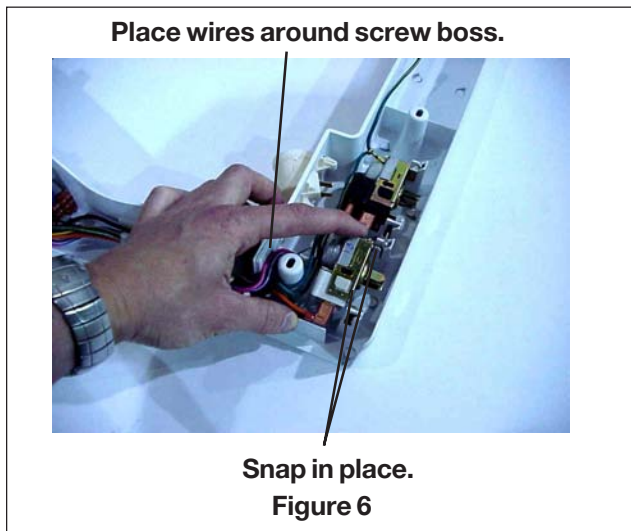

Figure 6

Route the wire harness and capillary tube through wireway, under boss screw, and snap into clip as shown in Figure 7.

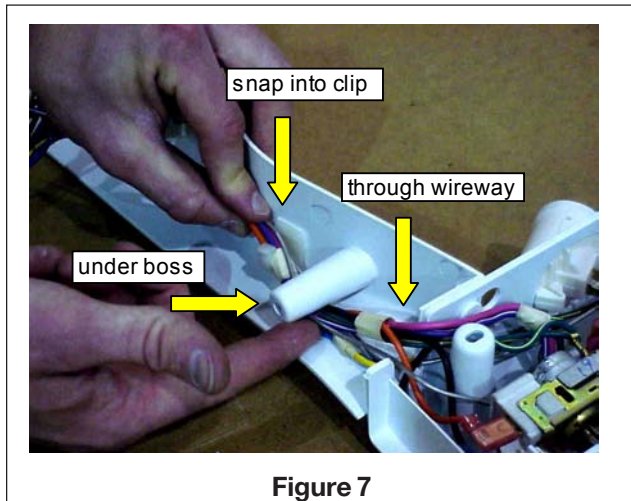

Figure 7

Snaps wires and capillary tube into clip behind defrost control. Place the plastic tube over the end of the control cap tube until it is even with the end of the tube. Make a 90° bend in the tube at the end of the plastic sleeve. (See Figure 8.)

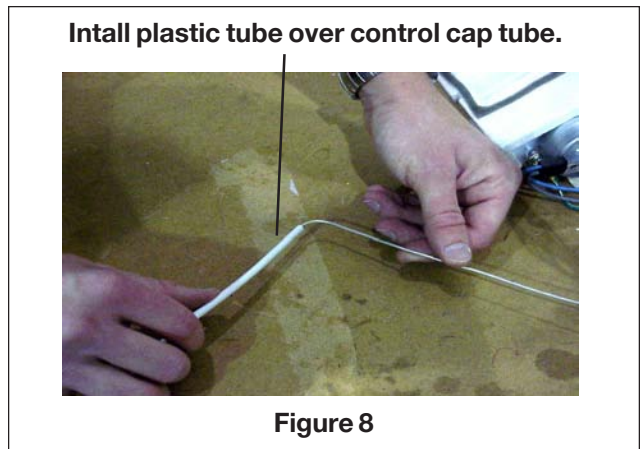

Figure 8

Tape freezer cap tube to damper control and install damper into rear control box. (See Figure 9.) Slide the end of the cap tube in the slot under the air duct which runs from the freezer to the fresh food compartment until the seal on the damper housing contacts the liner. Install the screws to hold the control housing in place.

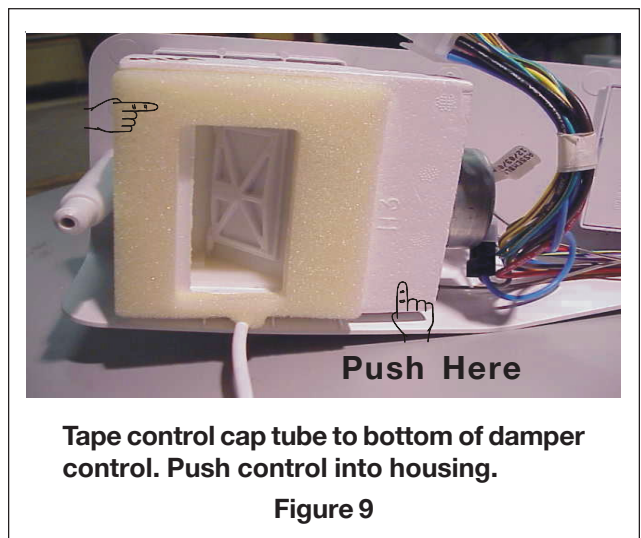
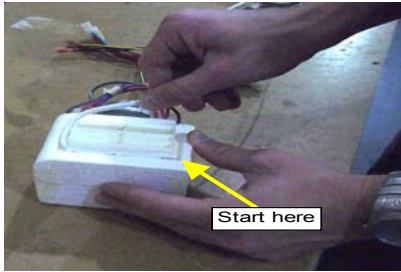

Figure 9

Fresh Food Compartment Control

The *Fresh Food Compartment Control* is located on the right side on the front control box. The cap tube for the control runs alongside the freezer cap tube back to the damper control. Like the freezer control, the last 8 inches is covered with a plastic sleeve. The end of the cap tube with the sleeve is snapped into a channel in the air diffuser in front of the damper control. (See Figure 10.) The Fresh Food Compartment Control will have an OFF position for the servicer to use in testing, but the word "OFF" will not show on the dial plate. To turn the control OFF, turn knob counterclockwise past WARM to the straight down position and you will feel the OFF position.



Press cap tube with plastic shield in channel on diffuser.

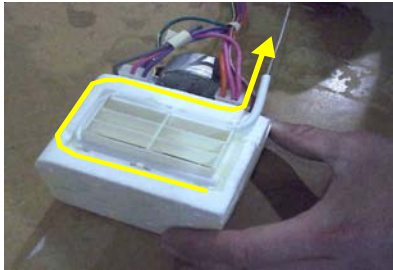

Figure 10

When the control is off, the damper should close and the fan should shut off, if the compressor is not running. To replace the Fresh Food Compartment Control, remove screw and drop housing (follow freezer control instructions). Snap control out of housing, then remove damper control and cap tube for control. Connect wiring to new control as shown in Figure 11.



Invensys
 3 White
 2 Black

FIGURE 11

Place control metal wing in solid clip first, then snap other side in place. Route wires and cap tube behind boss. (See Figure 12.)

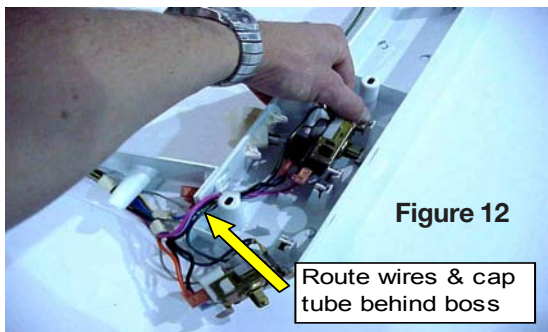

Figure 12

Place the air damper in the housing and reinstall housing in the fresh food compartment.

Air Damper Control

The air damper is used to control the fresh food compartment temperature by controlling air flow into the food compartment from the freezer. (See Figure 13.)

Damper Control



Figure 13

When the food compartment control calls for cooling, the contacts in the control will close sending a signal to the ADC. The ADC then will start the damper motor running to open the damper. (See Figure 14.)

As the damper motor opens the damper, the switches on the damper will change from NO (normally open) to the NC (normally closed) position one at a time to prevent the stopping of the motor in a 1/2 open position, as a result of a power outage as the damper is opening or closing. When both switches have reached the NC position, the damper will be all the way open and the motor will stop.

The damper will remain open and the fan motor will continue to run as long as the food compartment control calls for cooling. Once the food compartment control is satisfied, the contacts in the cold control will open. This will brake the signal to the ADC and start the damper motor running again, closing the damper and shutting off the freezer fan motor.

As the damper motor closes the damper, the switches on the damper will change from the NC to the NO position one at a time. When both switches have reached the NO position, the damper will be all the way closed and the motor will stop.

CONTROL HOUSING WIRING

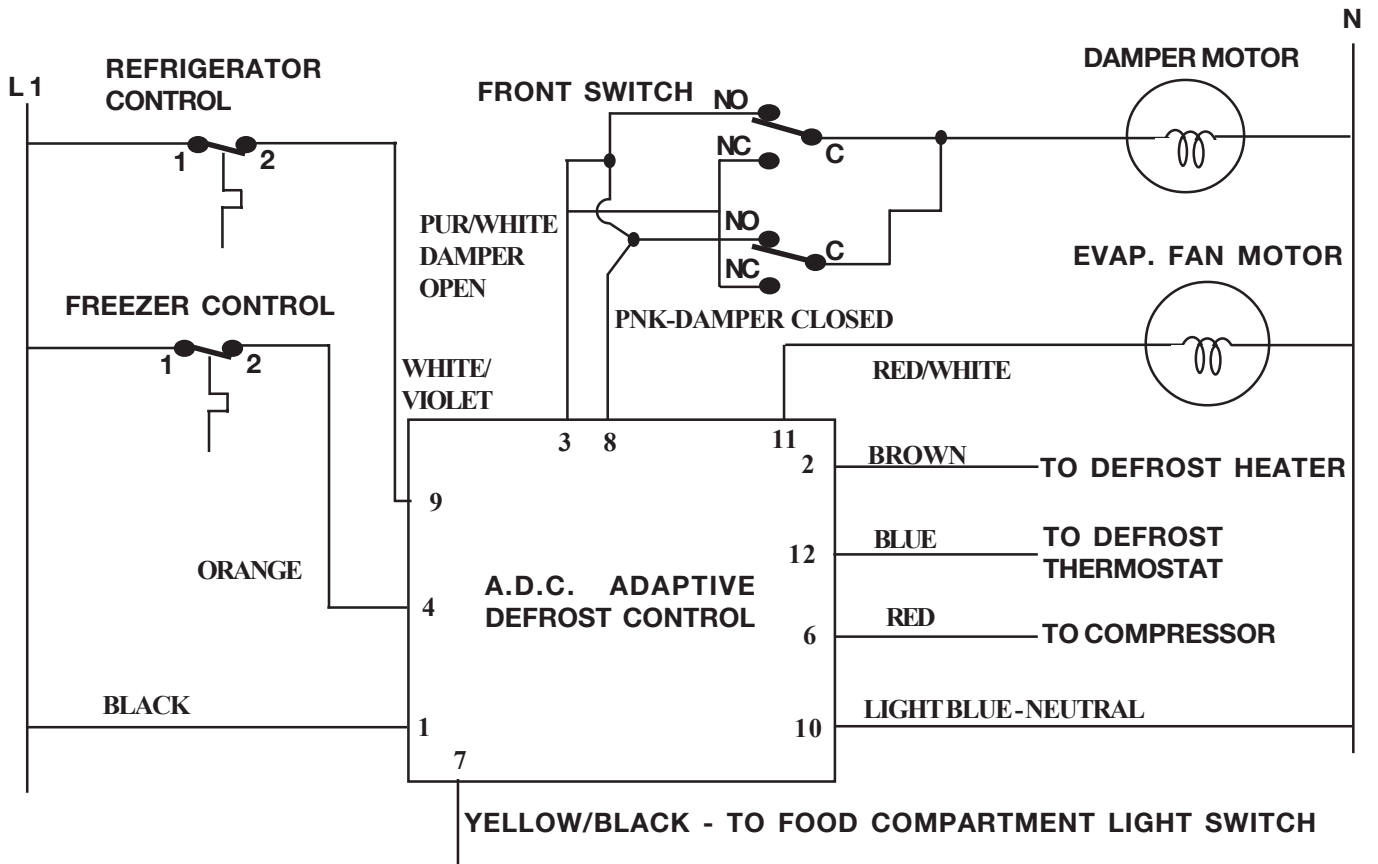
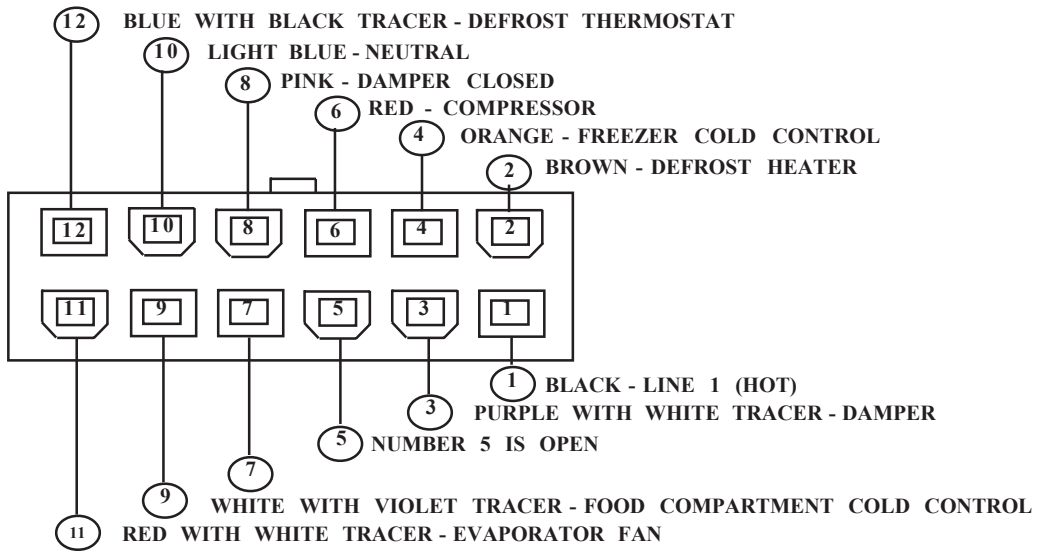

FIGURE 14 **NOTE:** SWITCHES WILL CLOSE AND OPEN ONE AT A TIME TO PREVENT STALLING IN A HALF OPEN POSITION AS A RESULT OF A POWEROUTAGE

Defrost Control

The ADC 11(Adaptive Defrost Control # 2) is used on all Side by Side with mechanical control system. (See Figure 15) In addition to controlling the defrost cycles the ADC supplies power to the evaporator fan motor, the compressor and condenser fan motor as well as the damper motor.



Figure 15

- Voltage between number 1 (BLK-HOT) and number 10 (LT BLU-Neutral) on the ADC is 115 VAC \pm 10%, 60 Hertz. This supplies the power to operate the processes, Evaporator fan motor and Damper motor.
- The freezer cold control (4) supplies line voltage to the ADC relay common contact to run the compressor and condenser fan motor, as well as the defrost system. It also supplies the signal to run the evaporator fan motor that is connected to 11. The board has a built in 6 minute delay on starting the compressor after the Defrost limit thermostat has shut the defrost heater off. This is to allow the evaporator time to drain.
- The food compartment cold control (9) also supplies the signal to the board to run the evaporator fan motor and tell the ADC to start the damper motor opening the damper door. When the control contacts open braking the signal, the ADC will turn the damper motor back on and close the damper door.
- The defrost thermostat is sensing the suction line temperature. The contacts will open to shut off the defrost heater at 47.5 F. The wire connected to the 12 position on the ADC receives a change in the signal from the defrost thermostat indicating the heater has cut off. This change in signal change will start the 6 minute drip time before the compressor restarts.
- The Food Compartment Door Switch has a wire connecting to (7) on the ADC. Sensing is between the door switch and the light bulb. This signal change is used to manually put the refrigerator into a defrost cycle and is used to monitor door openings for the vacation mode.
- The evaporator fan motor is connected to (11) on

the ADC. This will allow the fan to run when the food compartment control or the freezer control is calling for cooling. The board also has a built in 7 minute delay on starting the evaporator fan motor after the Defrost thermostat has shut off the heater. This is to allow the evaporator to drain and the temperature to drop slightly before starting the fan motor.

Output Voltage

- Output voltage to the defrost heater (2) and compressor (6) is equal to the input voltage from the freezer control (4). The PC board will withstand the following electrical loads for temperatures as high as 110° F.

Amps	Duration of Load	Reason for Load
15	3 Seconds	Locked Rotor
5	30 Minutes	Defrost Heater
3	Indefinite	Compressor Running

The ADC will dissipate an average of no more than 0.4 watts. The normal operating life is 22,000 defrost cycles over a 15 year period.

Initial Start & Power Interruptions

When power is applied to the power cord:

- If the defrost termination thermostat is closed, the compressor will start and the ADC will start a defrost cycle after 1 hour.
- If the defrost termination thermostat is open, a compressor cycle starts immediately. The ADC will start the first defrost cycle in 6 hours of compressor run time.

ADC Characteristics

The ADC has a base defrost interval of 6 hours of run time. All defrost interval timing starts with the compressor pull-down after a defrost or initial cabinet power.

When time for defrost:

- If the compressor has been running equal to or more than one hour, defrost immediately.
- If the compressor continues to run less than one hour, initiate the defrost at beginning of next "NO" cycle.
- If compressor continues to run for one hour after time for defrost, initiate the defrost immediately after that one hour.

The maximum defrost cycle is 30 minutes. If the Defrost thermostat does not open shutting off the defrost heater the ADC will shut off the heater and start the compressor after 30 minutes. After each defrost termination, there must be a 6 minute delay before compressor start and one additional minute before evaporator fan start. The exception is if the heater is on the full 30 minutes, the

compressor will start as soon as the heater shuts off and the fan will start in one minute.

Vacation Mode

When the defrost interval has reached 12 hours or less and the door has not been opened in the last 24 hours, the ADC places the product in vacation mode. Once in vacation mode, the defrost heater will be turned on after 96 hours. Should the door not be opened but the heater runs for longer than 16 minutes, then the ADC control restarts in 6 hours. Once the ADC control unit has entered vacation mode, if the food door is opened and the compressor run time since the last defrost has been at least 5 hours, a defrost is initiated after one hour of compressor run time since the initial door opening.

The maximum defrost cycle must be terminated after 30 minutes. After each defrost termination, there must be 6 minute delay before compressor start, except no time delay when the defrost heater has been on for 30 minutes.

System Diagnostics

An electrical connection between the light switch and refrigerator light bulb is coupled to the ADC system board, providing a manual method of initiating defrost and back to compressor. The actuation code will be a minimum of (5) depressions of the light switch within a (6) second time period.

- If a defrost is initiated manually and the termination thermostat is closed, the heater will be actuated until the termination thermostat opens. A 6 minute drip time follows before actuating the compressor and setting the next defrost time.
- When terminating the defrost manually and the termination thermostat is closed or open, the compressor is activated and sets the next defrost time.

An electrical connection between the defrost heater and the defrost termination thermostat is coupled to the ADC for system data, but also gives the technician the ability to check electrical continuity individually of either the defrost heater or termination thermostat from the ADC mounting area.

The ADC printed circuit board has component identification and lead wire color (name) listed on the cover over of the heat resistant box the ADC is mounted into.

NOTE: Because the evaporator fan motor operates through the ADC control, you can not replace the ADC with a defrost timer.

To check input power to the board: (See Figure 14.)

1. Check voltage between 1 and 10. You should have 115 VAC \pm 10% as long as the refrigerator is connected to house current.
2. If the freezer control contacts are closed, there should have 115 VAC \pm 10% between 10 and 4. If no

voltage is present, check control.

3. If the food compartment control contacts are closed, there should be 115 VAC \pm 10% between 9 and 10. If no voltage is present, check control.
4. With the door open and the food compartment light switch contacts closed, there should be 115 VAC \pm 10% between 7 and 10. If no voltage is present, check light switch.

NOTE: Remember to initiate defrost with the light switch, **both the switch and the light bulb** must be operating. The board is looking for the change from L1 when the switch is closed and Neutral through the light bulb, when the switch is open.

To check output power from the board: (See Figure 14.)

1. If there is voltage coming in from the freezer or food compartment control, there should be 115 VAC \pm 10% between 10 and 11 to operate the evaporator fan motor, unless it is in defrost or within the 7 minute delay after defrost. If no voltage is present, replace the board.
2. If there is voltage coming in from the freezer control, there should be 115 VAC \pm 10% at either 2 to 10 if the relay is set in defrost, or 6 to 10, if the relay is set for the compressor to run.
3. If there is voltage between 6 and 10, the compressor and condenser fan should be running. If they are not, check the voltage at the compressor. If voltage is present, follow procedure to check compressor. If voltage is not present, check wiring between ADC and compressor.

NOTE: To change relay from compressor run to defrost, open door and push light switch in and out 5 times within 6 seconds. The relay contact should open from Number 6 and close to number 2 shutting off the compressor and supplying power to the defrost heater.

4. If there is 115 VAC \pm 10% between 2 and 10, there should be power to the defrost heater. If the limit switch is closed, the heater should be on. If the heater is not operating, check the voltage between 12 and 10. If the heater is not working but line voltage is present, the heater is open. If the heater is not operating, and there is no voltage between 12 and 10, the limit switch is open.
5. To open the damper door the ADC will get 115 VAC \pm 10% from the food compartment cold control on number 9 terminal. The ADC will then supply 115 VAC \pm 10% to the number 3 contact starting the damper motor and opening the damper. If the food compartment control contacts are closed you should have 115 VAC \pm 10% between 9 and 10 if not check the control and wiring to the control. If voltage is present between 9 and 10, you should have 115 VAC

$\pm 10\%$ between 3 and 10 supplying voltage to the damper motor switches and damper motor opening the damper door. If no voltage is present replace the ADC. If voltage is present check for voltage at damper switches if voltage is present and the motor will run replace the damper.

6. To close the damper door, the ADC will lose 115 VAC $\pm 10\%$ from the food compartment cold control on number 9 terminal. The ADC will then supply 115 VAC $\pm 10\%$ to the number 8 contact starting the damper motor and closing the damper. If the food compartment control contacts are open, you should not have 115 VAC $\pm 10\%$ between 9 and 10. If voltage is present, check the control and wiring to the control. If no voltage is present between 9 and 10, you should have 115 VAC $\pm 10\%$ between 8 and 10, supplying voltage to the damper motor switches and damper motor, closing the damper door. If no voltage is present, replace the ADC. If voltage is present, check for voltage at damper switches. If voltage is present and the motor will run, replace the damper.

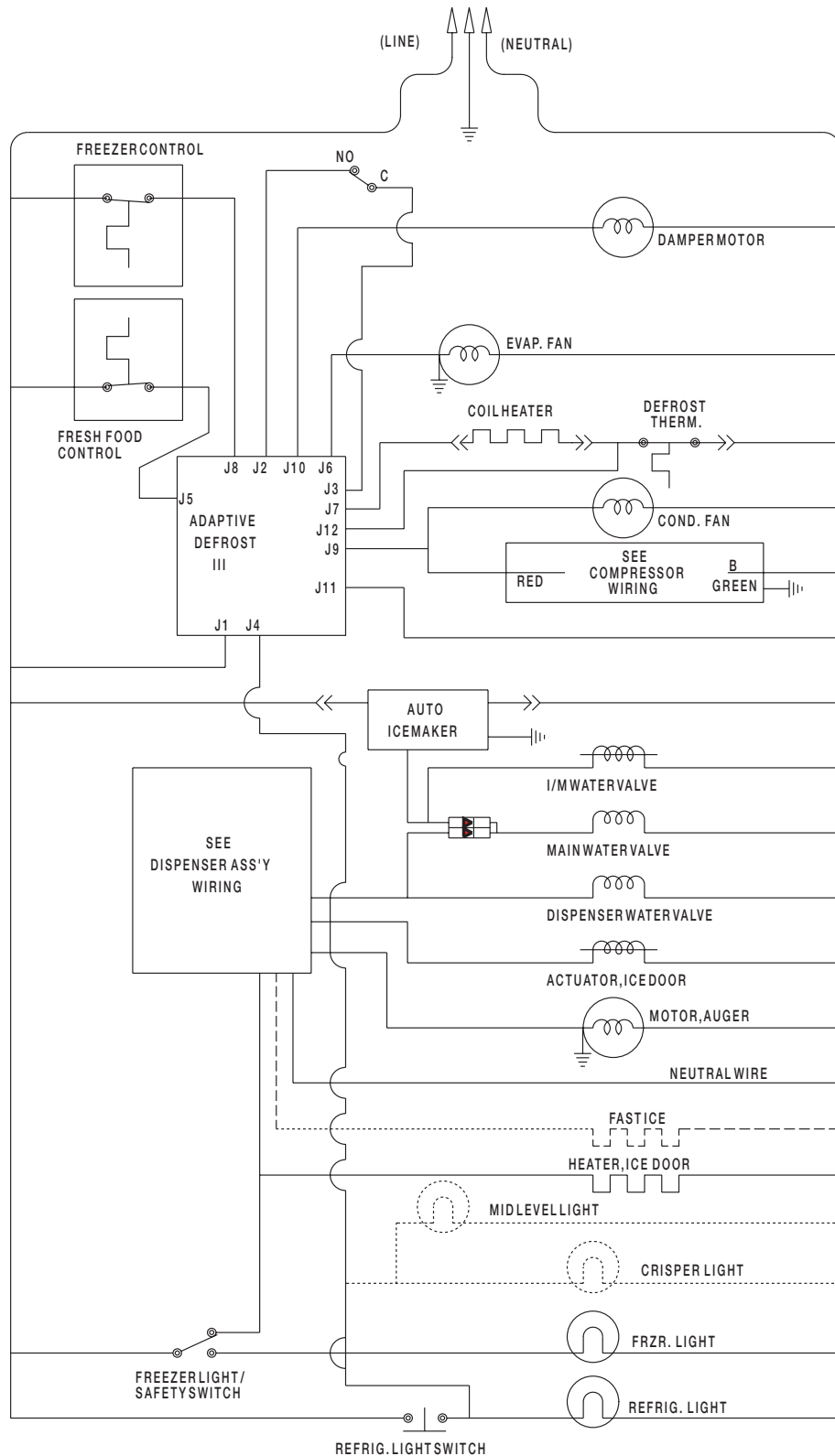

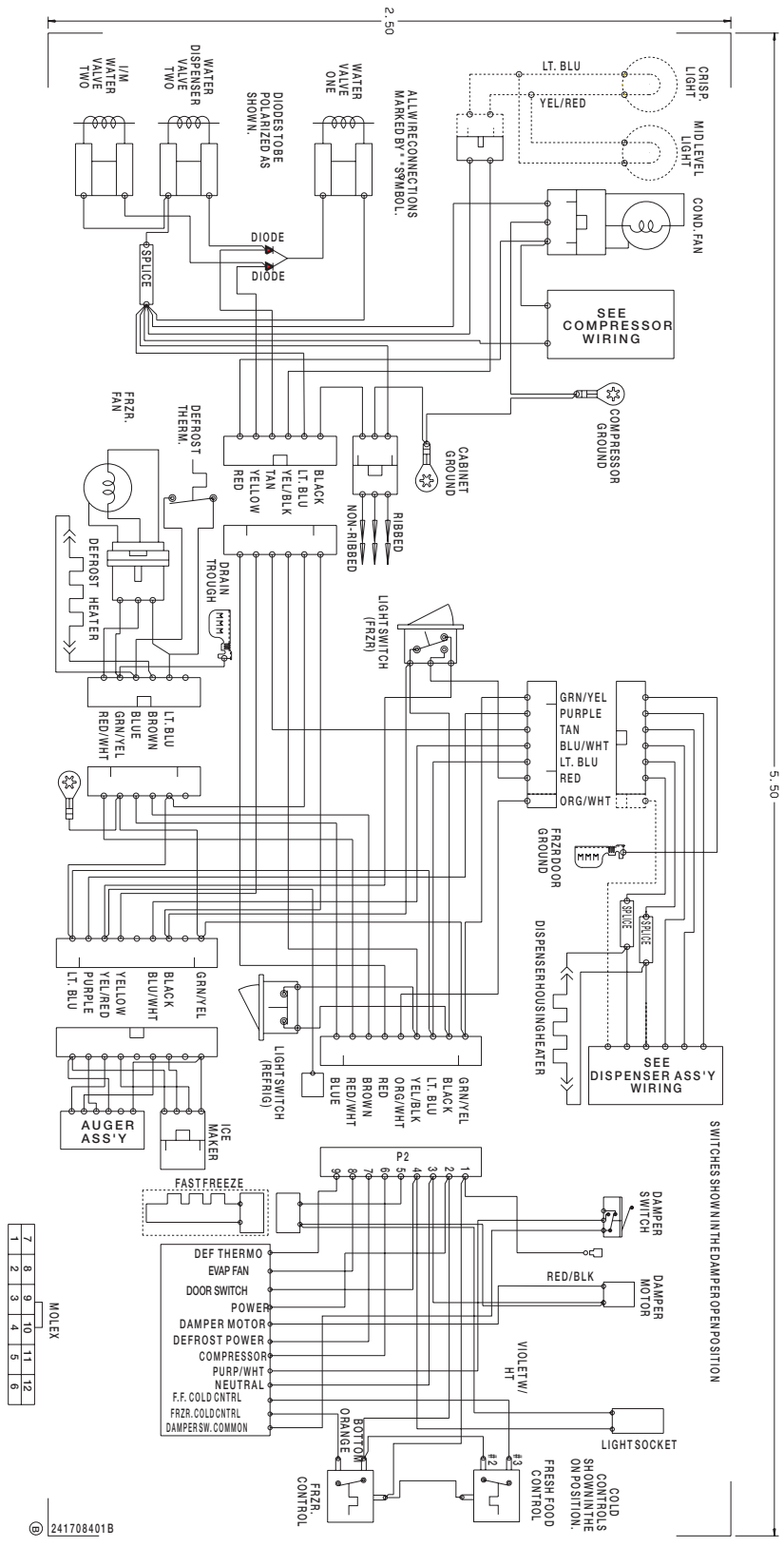

ELECTRONIC DISPENSER

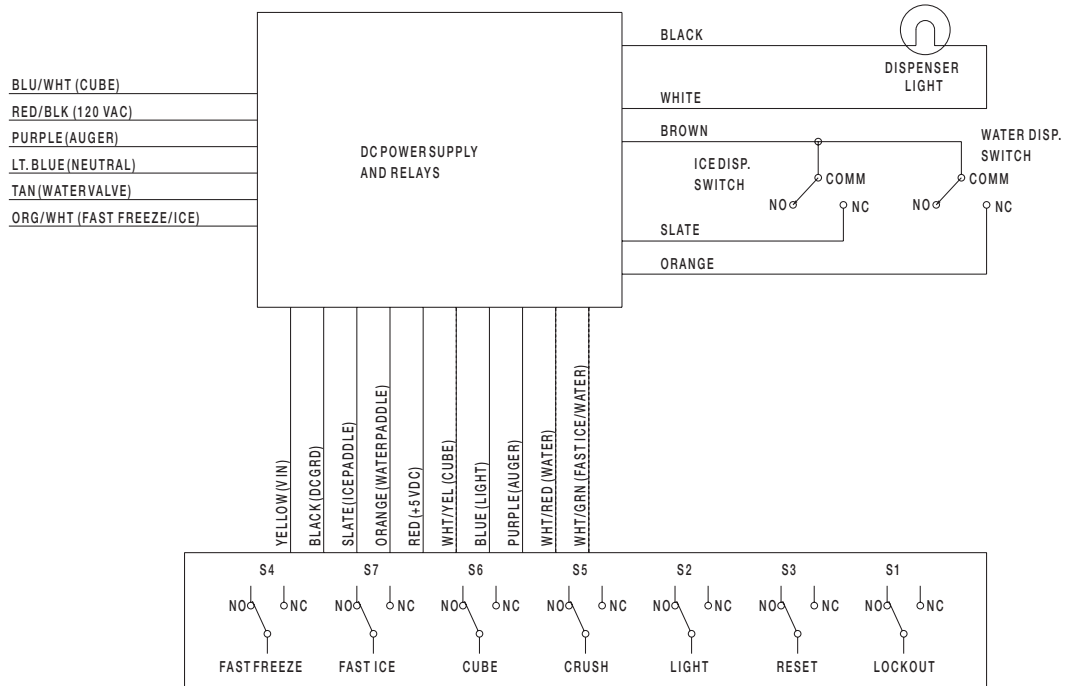

ELECTRO-MECHANICAL DISPENSER

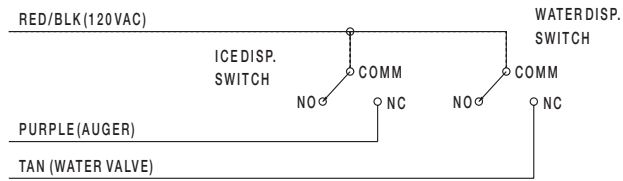

P.T.C. STARTER WITH RUN CAPACITOR

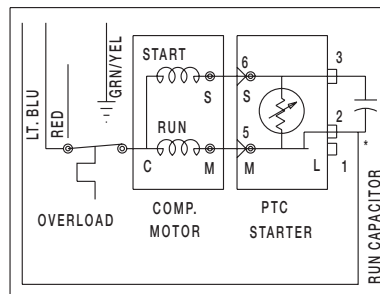

* CAPACITOR IS ONLY USED WITH SOME P.T.C. MODELS.

SYSTEM EXPLODED VIEW DIAGRAM

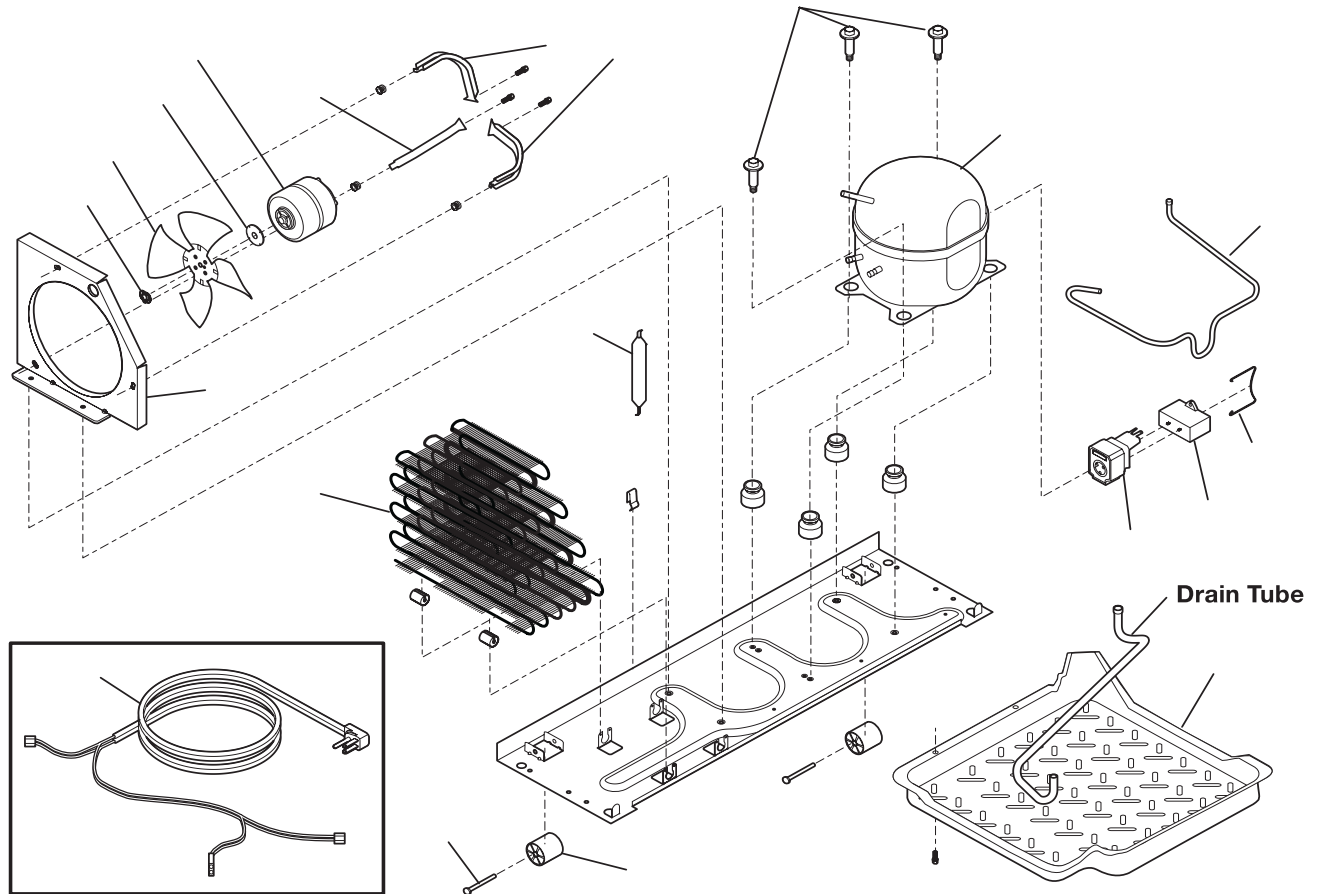
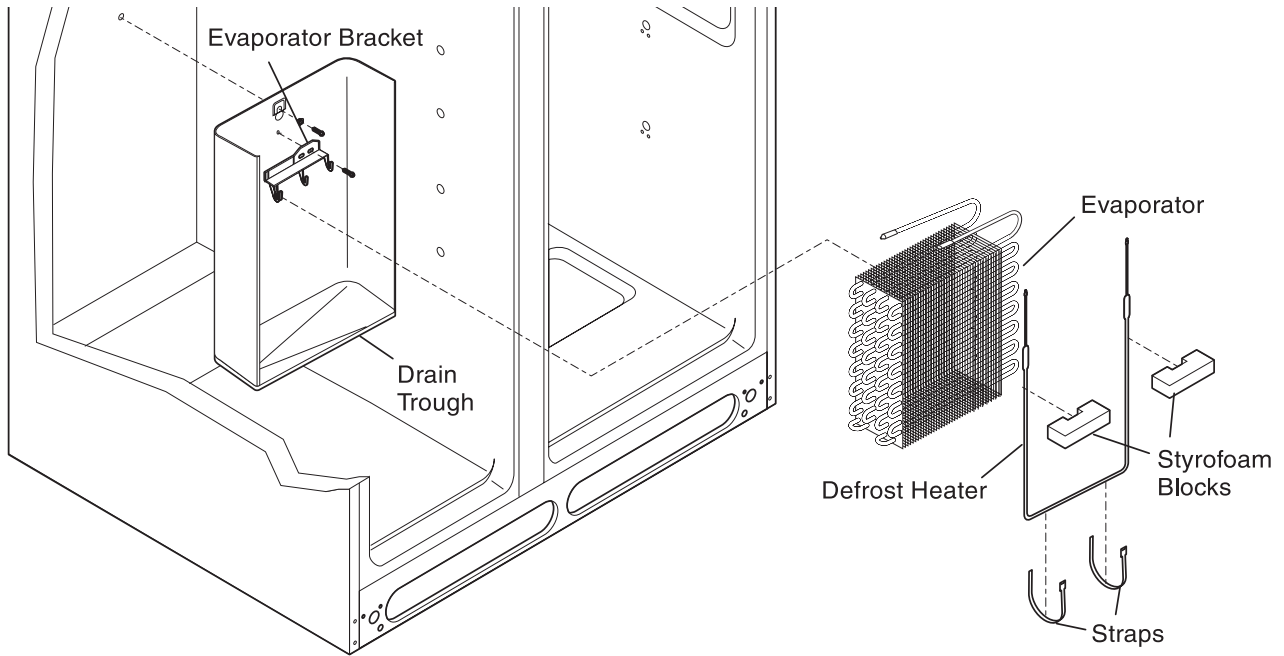

CONTROLS EXPLODED VIEW DIAGRAM (Rear Filter)

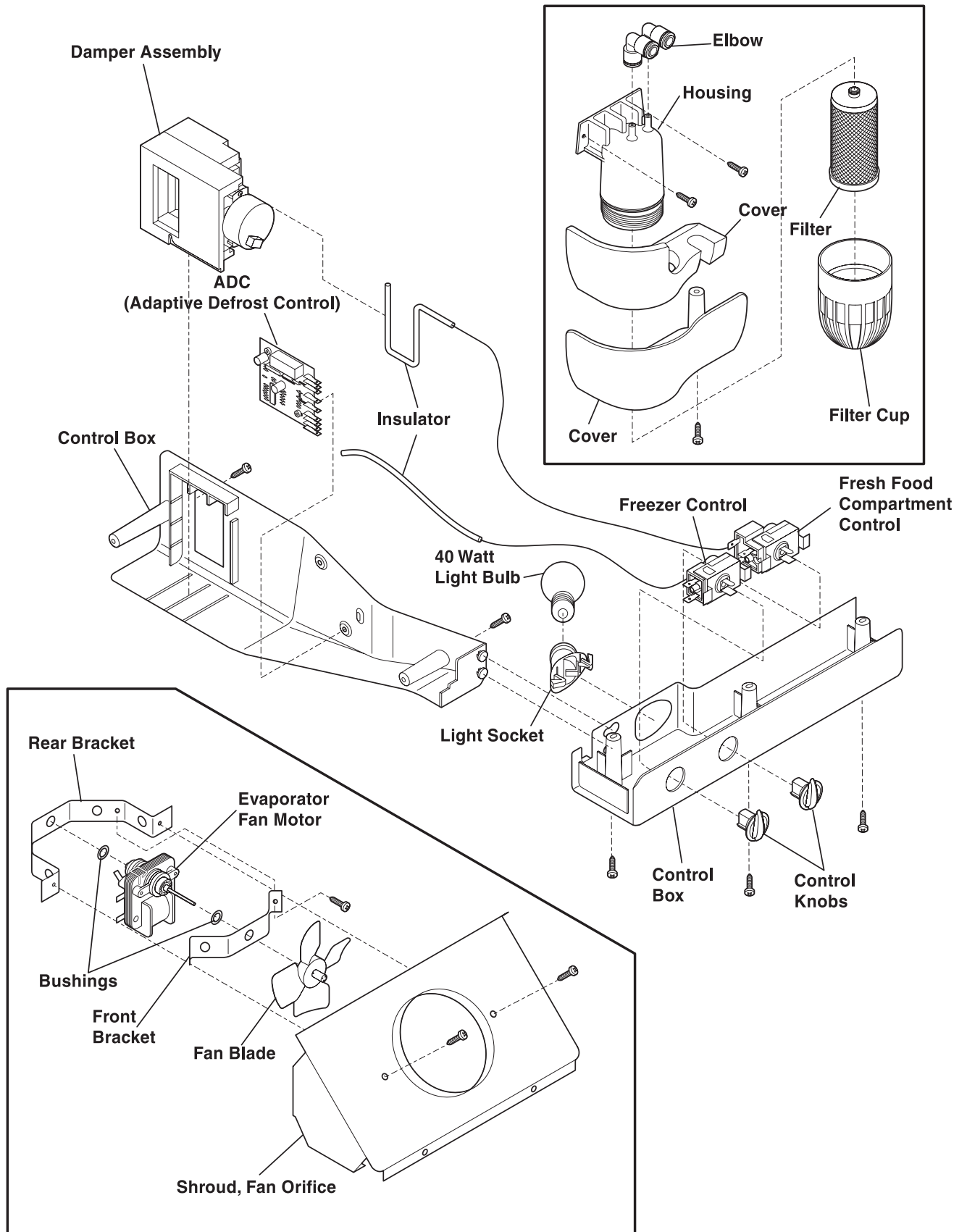

CONTROLS EXPLODED VIEW DIAGRAM (Front Filter)

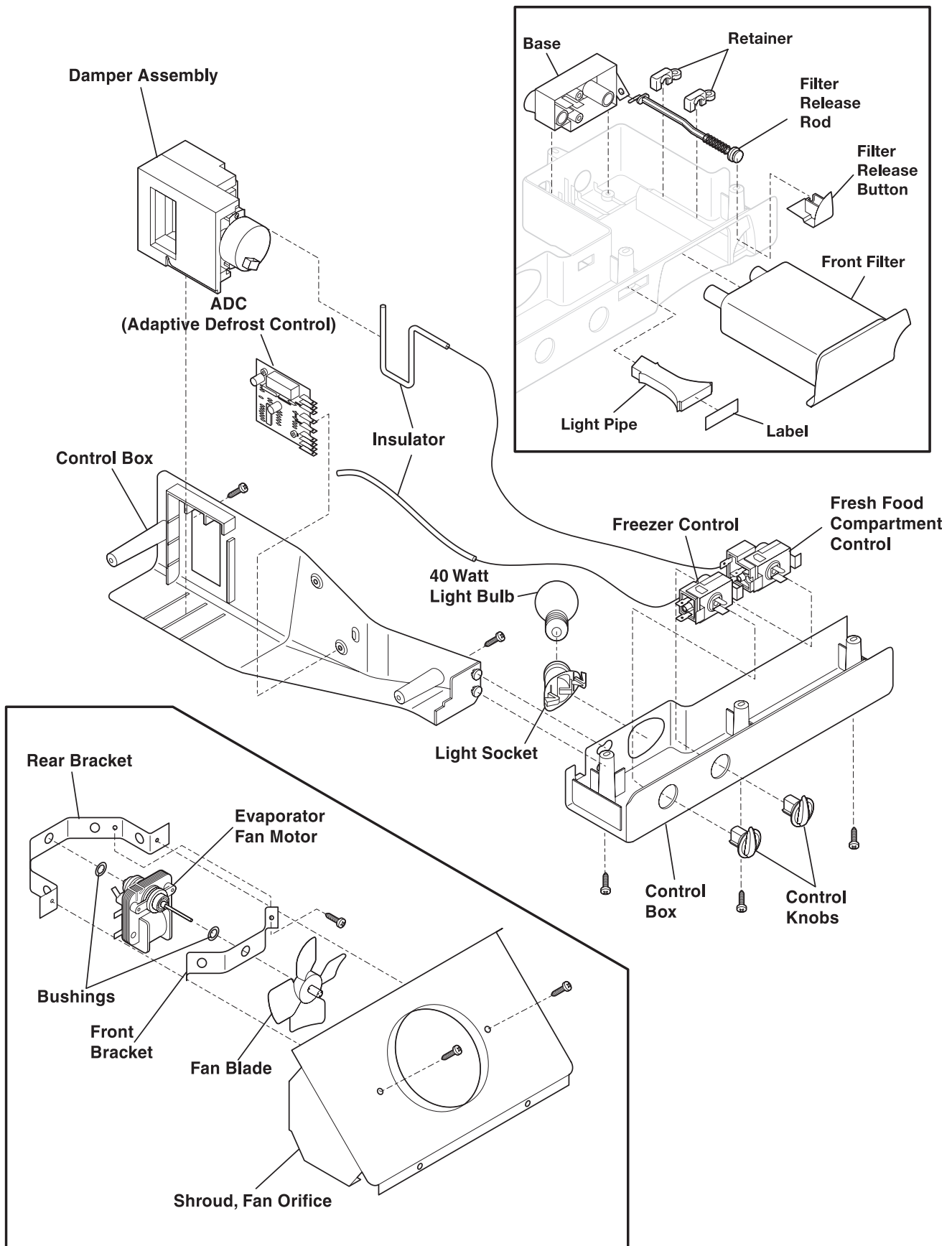

ELECTRONIC CONTROL SYSTEM



The **ELECTRONIC** control is located inside the housing mounted in the food compartment, along with the light and damper assembly. See Figure 1.

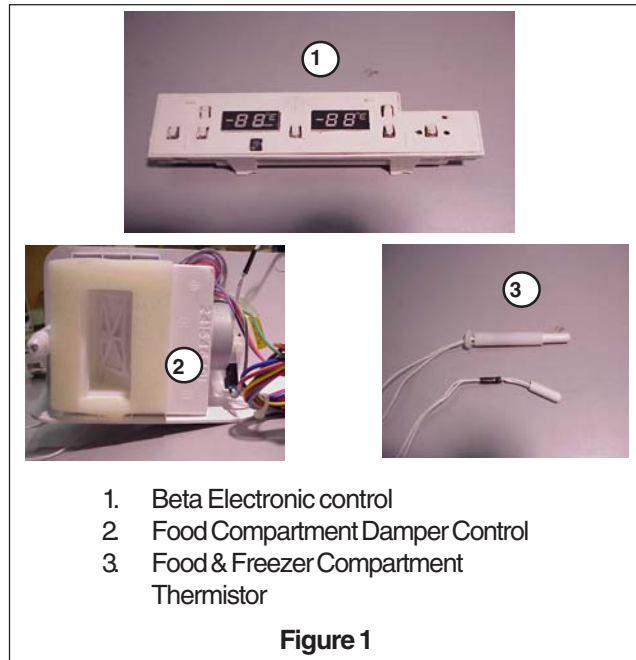

To remove the *Control Housing Assembly*, remove the three screws at the front of the control box, and the two screws located in the rear of the control box. After removing the cover over the water line on front filter models, remove the screw from the back of the control box. (See Figure 2.)

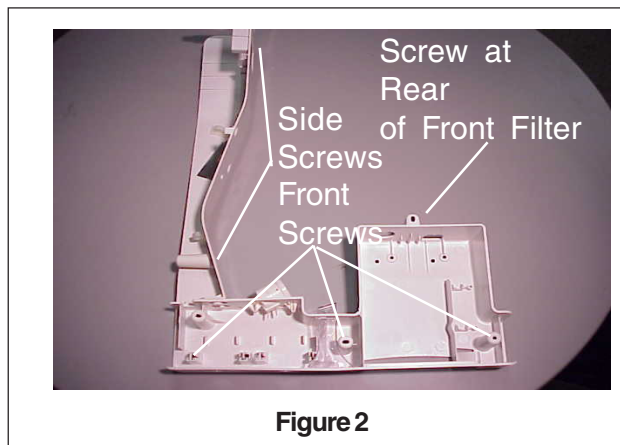

Separate the two housings at the left back of the front housing by sliding the rear housing to the right until the buttons line up with the larger hole in the slots. (See Figure 3.)

Electronic Control

The control is mounted on the left (as shown in Figure 4) It controls the cycling of the compressor, condenser fan motor, damper motor, evaporator fan motor, as well as the defrost cycle.

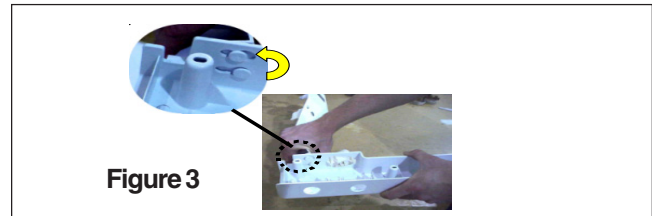

The door alarms are also part of this control. (See Figure 4.) The freezer and food compartment thermistors plug into the back of the control at the top. The main electrical connector is plugged in at the bottom left corner of the control. To remove the control from the housing, disconnect the two thermistors from the top of the control and disconnect the wiring harness from the lower connector. Push the front of the control box forward to clear the display windows and slide the control straight up and out of the housing. Reinstall in reverse order.

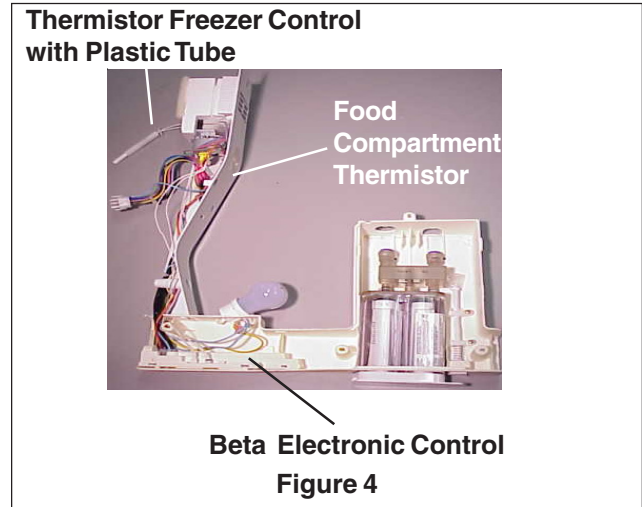

Start up Test

At the time the product is connected to line voltage it will run a self test. If all components pass a your set points will appear in the display. If there is a failure you will see a fault code appear in the display.

- Test 1 - Evaporator fan motor. Alternating E in food display F in freezer display indicates test failed.
- Test 2 - Freezer Thermistor. Flash 2 or 3 if failed test
- Test 3 - Food Thermistor. Flash 2 or 3 if failed test
 - Flash "2" Thermistor is open
 - Flash "3" Thermistor is sensor shorted
- Test 4 - Damper - Flash "4" in food display indicates the damper test failed

ELECTRONIC CONTROL SYSTEM FOR GENESIS CONTROL REFRIGERATORS

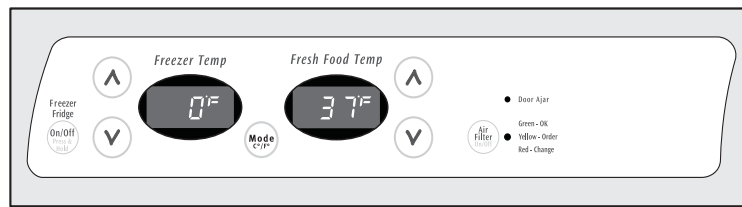

DESCRIPTION

Damper Assembly

Motorized door (115 VAC \pm 10 %) located between the freezer section and the fresh food section in the back of left side of control box of the refrigerator. This control system uses the same damper as the electro-mechanical control system covered in previous section.

Freezer Temperature Control

Electronic thermostat regulating the temperature of the frozen food section. A Negative Temperature Coefficient Thermistor monitors freezer compartment temperature. Loads controlled are the compressor, condenser fan and evaporator fan motor.

Fresh Food Temperature Control

Electronic thermostat regulating the temperature of the fresh food section. A Negative Temperature Coefficient Thermistor monitors Fresh Food Compartment Temperature. Loads controlled are the damper motor and evaporator fan motor .

Defrost Heater

A 450 watt heating element (115VAC) is located in the evaporator assembly to melt frost during the defrost cycle. The defrost heater is connected to the NO contact of a relay. Defrost Heater Operation is detected and internally monitored by the microprocessor.

Defrost Termination Thermostat (DTT)

Bi-metal disc thermostat attached via a clamp to the evaporator tubing. During the defrost cycle, the device is a closed circuit between the defrost heater and Neutral. The DTT is designed to open at a predetermined temperature, ending the defrost cycle.

Compressor

Motorized pump (115VAC) that creates the high and low pressures required for heat exchange. The Compressor is controlled by a relay.

Evaporator Fan

Motorized Fan (115 VAC) that circulates freezer and fresh food section air. The evaporator fan motor speed is controlled via a triac located on the control board.

Condenser Fan

Motorized Fan (115VAC) that circulates air through the condenser coils. The relay controlling compressor is used to control the condenser fan motor.

Fresh Food Door Switch

Single pole, single throw mechanical switch.

Air Filter

Motorized Fan (12VDC) that circulates air through a filter in the Fresh Food Section.

Sensors

Negative Temperature Coefficient Thermistor.

Alarm

Audible Transducer (Piezo)

Control, Main Board

Power Supply -AC Input Voltage – 115 V AC @ 60 Hz.

Numeric Display

Version A

2-digit, 7 segment numeric with degrees symbol, minus sign segment and a 4 segment character to represent F and C.

Version B

1-digit, 7 segment numeric.

Fresh Food Door Sensor

Magnetically activated reed switch. Switch will detect Fresh Food Door state.

Show Room Setting

Active Function

Displays

Freezer/Fresh Food Temperature Keys

Fresh Food Lights

Air Filter Key.

Key Tone and green LED toggles on & off.

All other functions are disabled including alarm(s) enabling.

Alarms and Signals

Door Ajar LED (flashing green)

Either door open for 5 minutes, this light blinks and control beeps.

Condition is reset if the opened door is closed.

Disabling Door Ajar Alarm Audio.

Press and hold Freezer UP Key while pressing the Fresh Food DOWN Key 3 Times. Only the audio transducer is disabled. Door Ajar monitoring and LED remain enabled.

Enabling Door Ajar Alarm Audio after Disabling.

Press and hold Freezer UP Key while pressing the Fresh Food DOWN Key 3 times.

Alarm Condition

Alarm is enabled and active. Alarm LED (Green) is ON and steady state.

Show Room Setting

Activation

Press and hold Fresh Food Temperature UP (WARMER) Key while pressing the fresh food temperature DOWN (COLDER) key 3 times within 5 seconds. Both displays will flash "0" for 10 seconds. While the displays are flashing, press the Freezer Temperature UP key to confirm activation

Deactivation

Mode automatically deactivates at a power on reset

Active Function

Displays

Freezer/Fresh Food Temperature Keys

Fresh Food Lights

Alarm Key. (Key Tone ONLY)

Air Filter Key. (Key Tone and green LED toggles on & off.)

All other functions are disabled including alarm(s) enabling

NOTE: The "Show Room" mode doesn't recognize Alarm/Power Off conditions during activation.

Change Between Fahrenheit and Centigrade (Models with mode Key Only)

To change form Fahrenheit to Centigrade, press the mode key.

Advance into defrost cycle manually.

Activation

Press and hold Freezer Temperature UP (WARMER) Key while pressing the fresh food temperature DOWN (COLDER) key 5 times within 6 seconds. This will advance the processor into defrost cycle.

Deactivation

Press and hold Freezer Temperature UP (WARMER) Key while pressing the fresh food temperature DOWN (COLDER) key 5 times within 6 seconds. This will advance the processor out of defrost cycle by making the control work as if the defrost limit switch had opened. You will still have the 6 minute drip time before the compressor starts and one additional minute before the evaporator fan will restart. Or just let the refrigerator alone and it will go through a normal defrost cycle and start running after defrost limit switch has turned off the heater and the controller has allowed for a normal drip time.

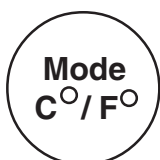

OPERATION - Control System

(Two Position Read out for Freezer and Food Compartment)



Freezer

Temperature UP key adjust temperature setting in one degree, F or C, each key press.

Setting Upper Limit = +6°F (-14°C).

One key press past +6°F = Off (All Loads. Damper Closed). Displays will show "off".

Temperature DOWN key decreases temperature setting one degree, F or C, each key press.

Setting Lower Limit = -6° F (-21°C).

Each key press (Temperature UP or DOWN) displays temperature setting. Actual temperature will be displayed after 10 seconds if no key entries are made as well as during normal operation.

Displays are off when Fresh Food Door is closed.

Communications remain active.

Default = 0°F (-18°C).

Fresh Food

Temperature UP key adjust temperature setting in one degree, F or C, each key press.

Setting Upper Limit = 47°F (8°C).

Temperature DOWN key decreases temperature setting one degree, F or C, each key press.

Setting Lower Limit = 33°F (1°C).

Each key press (Temperature UP or DOWN) displays temperature setting. Actual temperature will be displayed after 10 seconds if no entries are made.

Default = 37°F (3°C)

Air Filter Control (Not on all Models)

Pressing the "Air Filter" key activates the fresh food filter and turns the air filter LED (tri-color) on. Press "Filter" key again to deactivate and turn the air filter LED (tri-color) off.

When activated, the air filter fan motor is on until the customer turns off the motor and Air Filter LED.

Air filter fan motor run time is monitored during activation as to determine and display air filter status via LED color.

Green. 0 to 3600 minutes run time.

Amber.: 3600 to 4344 minutes run time.

Red = 4344 minutes run time.

Air filter status is reset by pressing and holding "Air Filter" key for 5 seconds.

Fast Freeze/Fast Ice Mode

Fast Freeze

Freezer temperature set point is adjusted to -6°F when this option is selected from the IWD (Ice and Water Dispenser). Set point will return to the previous setting after the mode terminates in 14 hours.

Fast Ice

Freezer temperature set point is adjusted to -6°F when this option is selected from the IWD. Set Point will return to the previous setting when the mode terminates in 12 hours.

Over Temperature Shut Off

Compressor operation is terminated at ambient temperatures over 85°C (185°F).

Compressor operation continues at 65°C (149°F).

Control System (One position read out for freezer and food compartments)

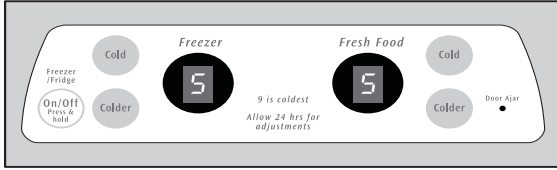

Freezer

Temperature colder key adjust temperatures one number with each key press. Setting Upper Limit = 9
Temperature warmer key decreases temperature setting one number with each key press. Setting Lower Limit = 0 (Off).

Number Setting to Temperature Conversion

0 = Off (All Loads. Damper Closed). Displays = "0".

1 = +6°F (-14°C).

2 = +4 (-15.5°C).

3 = +3 (-16°C).

4 = +2 (-17°C).

5 = 0°F (-18°C).

6 = -2°F (-19°C).

7 = -3°F (-19.5°C).

8 = -4°F (-20°C).

9 = -6°F (-21°C).

Displays are off when Fresh Food Door is closed. Communications remain active.

Default = 5.

Fresh Food

Temperature colder key adjust temperatures settings by one number with each key press. Upper Limit = 9
Temperature warmer key decreased settings by one number with each key press. Lower Limit = 1.

Number Setting to Temperature Conversion

1 = 47°F (8°C).

2 = 44°F (6.5°C).

3 = 42°F (5.5°C).

4 = 40°F (4°C).

5 = 38°F (3.5°C).

6 = 37°F (3°C).

7 = 36°F (2.5°C).

8 = 35°F (2°C).

9 = 33°F (1°C).

Default = 5.

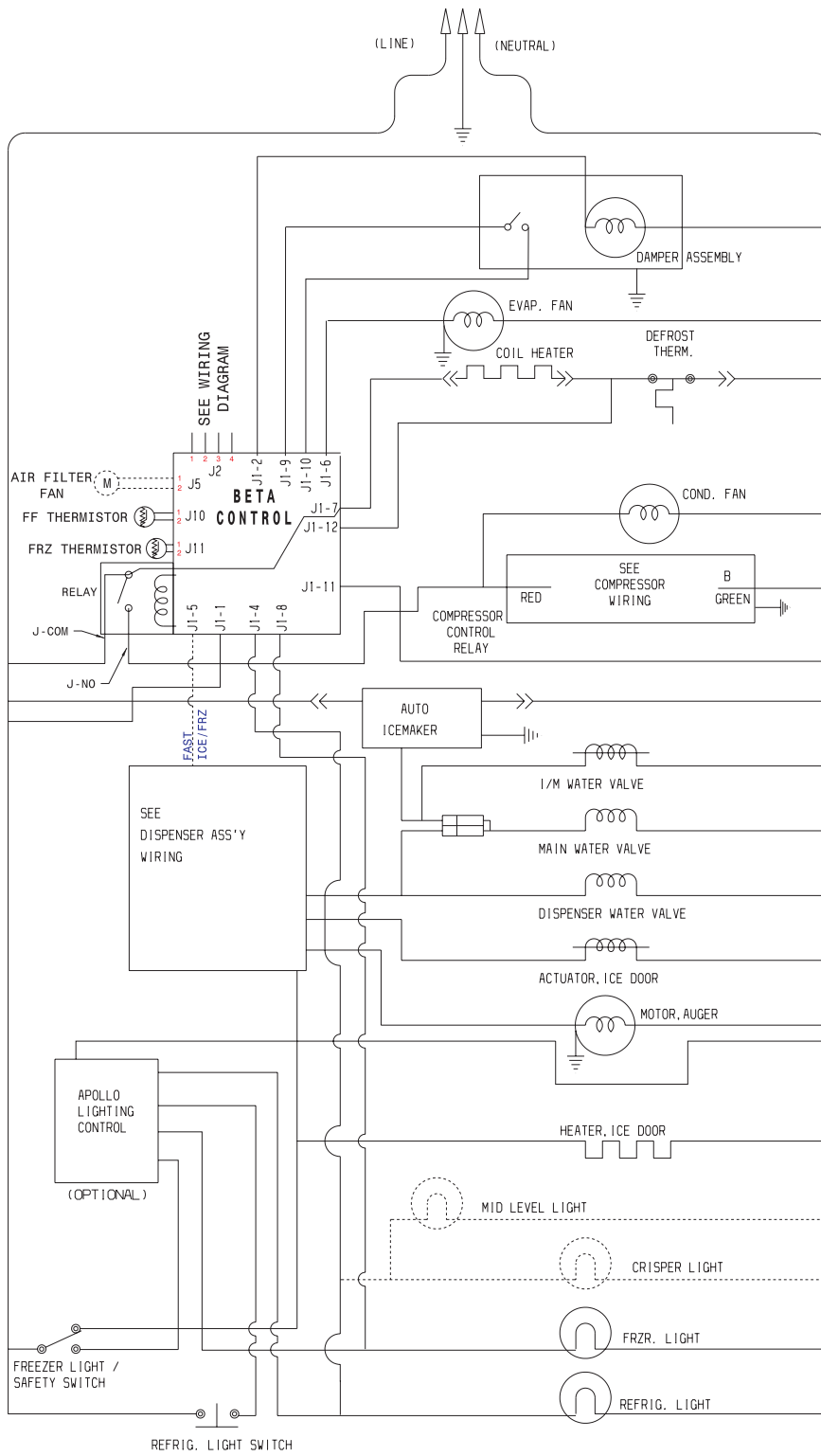

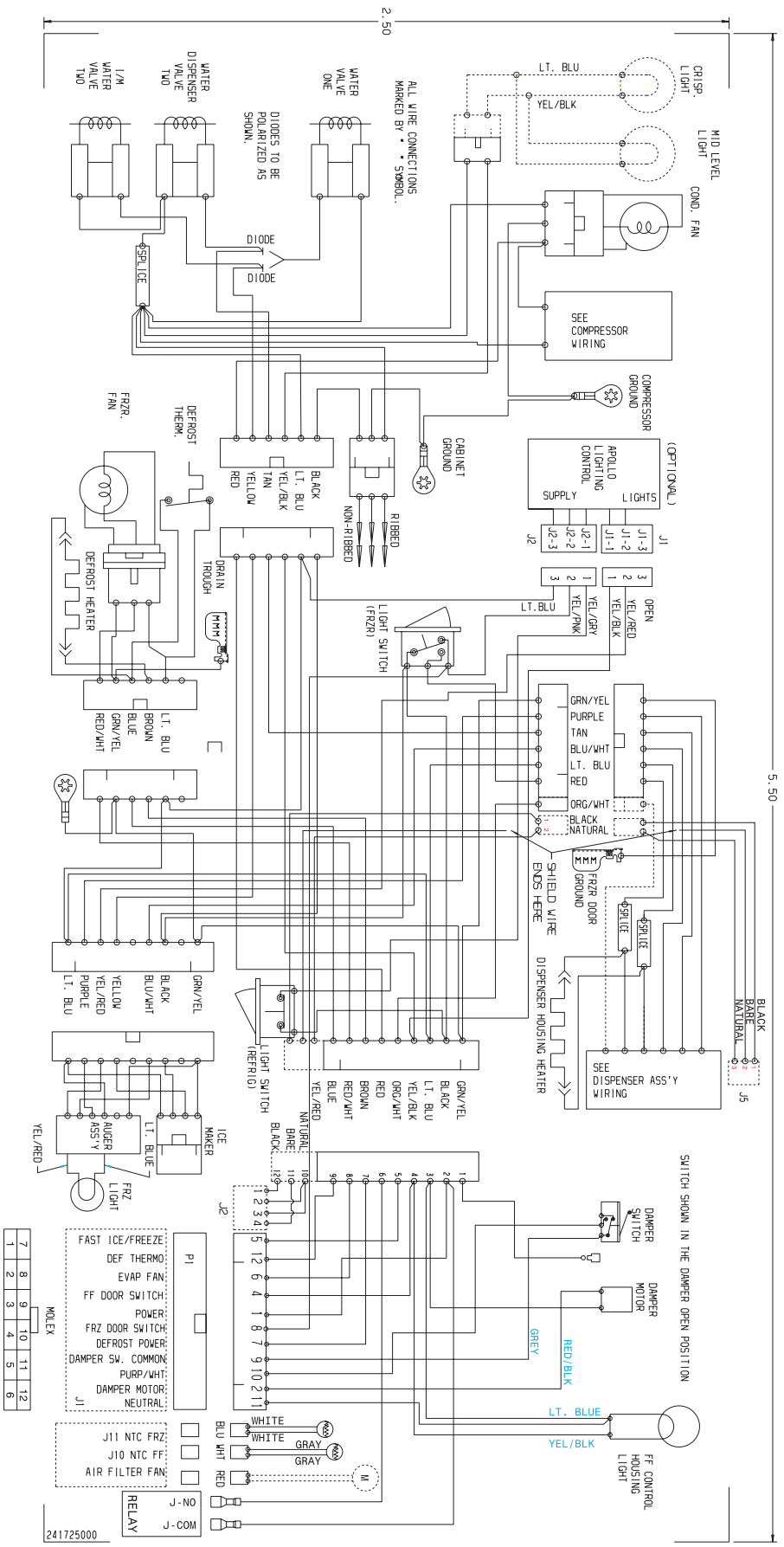

7	8	9	10	11	12
1	2	3	4	5	6

- FAST ICE/FREEZE
DEF THERMO
EVAP FAN
FF DOOR SWITCH
POWER
FRZ DOOR SWITCH
DEFROST POWER
DAMPER SW. COMMON
DAMPER MOTOR
NEUTRAL
- J1
- J11 NTC FRZ
J10 NTC FF
AIR FILTER FAN
- RELAY
J-NO
J-COM

241725000

ELECTRONIC DISPENSER

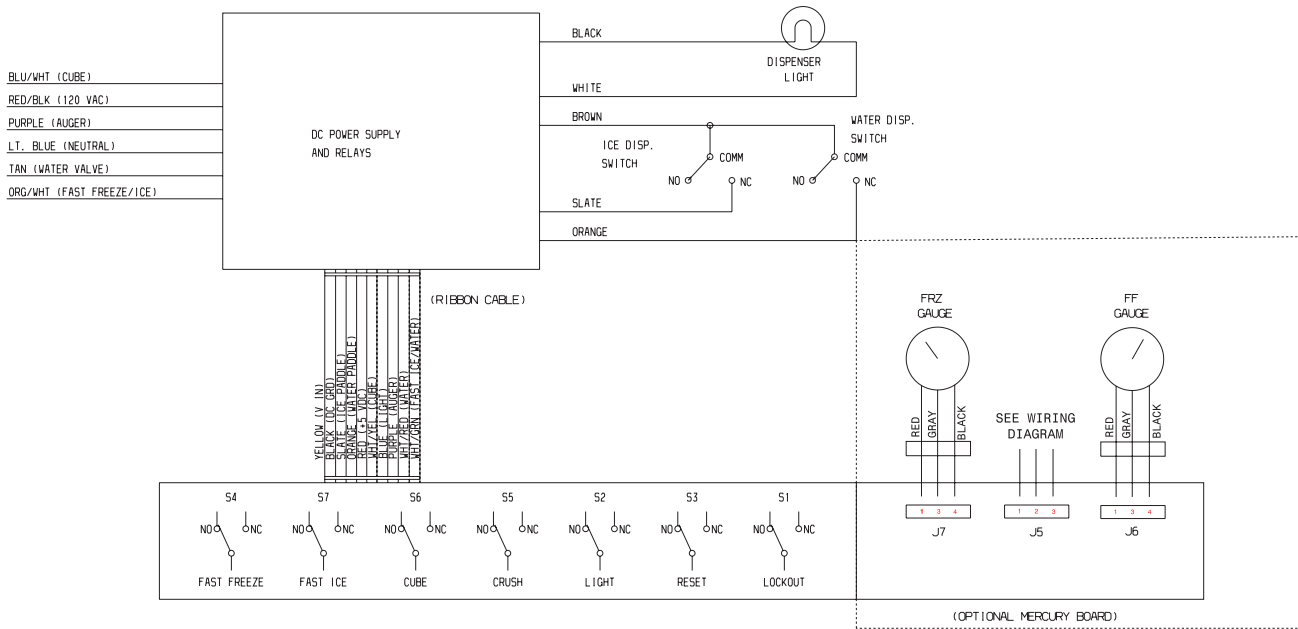

ELECTRO-MECHANICAL DISPENSER

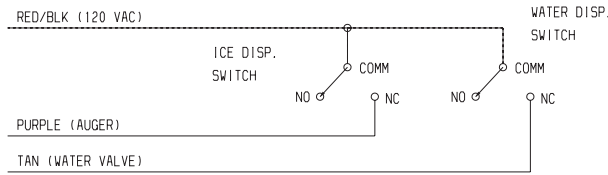

P. T. C. STARTER WITH RUN CAPACITOR

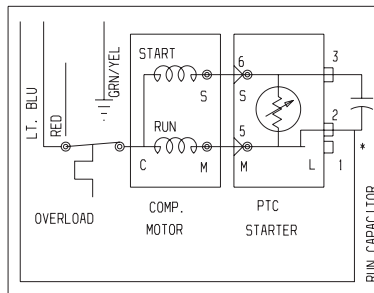

* CAPACITOR IS ONLY USED WITH SOME P.T.C. MODELS.

Service Diagnostics Mode

With a series of key presses, a service technician can view data, via the display and exercise loads to help troubleshoot the product. Following are a list of capabilities.

View

Firmware Version (What version of software)
Indicate an open or shorted sensor condition.

Test

Manually test sensors.
Run evaporator fan motor
Operate damper to full open, full close
Turn defrost heater on.
Turn compressor on.

To enter the test mode press and hold the Freezer Temperature UP (Warmer) key while pressing the Freezer Temperature DOWN (Colder) key 3 times within 5 seconds.



The freezer display will show "1". The fresh food display will be blank. Each press of the freezer temperature up (Warmer) or the freezer temperature DOWN (Colder) key will step you through the service menu tests, "1" through "8". Each press of the fresh food temperature UP (Warmer) or fresh food temperature DOWN (Colder) key will step you through variables of each test.

Note: If you are in test 1 and press the freezer up key you will go to test 8. At the start of test 1, if you press the food compartment UP key it will beep at you.

Deactivation

Press and hold Freezer Temperature "UP" key for 5 seconds. The control will beep and service mode is deactivated.
Mode automatically deactivates after 5 minutes of no key entry.

Service Test Menu

Test 1 Firmware Version
Variable 1. Display software version.

Test 2 Evaporator Fan Test
Variable 1. Motor runs at high speed continuously on 115 V AC



Test 3

Variable 1. Freezer sensor circuit condition;
Flash "1" Freezer sensor OK
Flash "2" Freezer sensor open
Flash "3" Freezer sensor shorted

Variable 2. Disables buffer to allow technician to place his finger on the freezer sensor and observe an immediate temperature rise.



Test 4

Variable 1. Fresh Food sensor circuit condition will be displayed in Fresh Food Window;
Flash "1" Fresh Food sensor OK
Flash "2" Fresh Food sensor open
Flash "3" Fresh Food sensor shorted

Variable 2. Disables buffer to allow technician to place his finger on the Fresh Food sensor and observe an immediate rise in temperature.

Note: The upper control limit is 2 degrees over set temperature.



Test 5

Damper Motor is a 115 V AC
Variable 1. Damper to full open
Variable 2. Damper to full closed



The display will show the following symbols to indicate the door position: **0 FULL OPEN**
— CLOSED

Test 6

Defrost
Variable 1. Will turn on defrost heater. If current flow to heater is sensed the letter 'D' will be displayed. If no current flow is sensed the letter 'D' will flash.

Test 7 Compressor and condenser fan on
Variable 1. Run compressor and condenser fan motor. The display will show the letter 'C' when the compressor and condenser fan are running.

Test 8 Default Settings

Variable 1. Display "1" Indicates default should show -88.

Manual Defrost

Activation

Press and hold Freezer Temperature UP (WARMER) key while pressing the fresh food temperature DOWN (COLDER) key 5 times within 6 seconds.

Deactivation

Press and hold Freezer Temperature UP (WARMER) key while pressing the fresh food temperature DOWN (COLDER) key 5 times within 6 seconds.

Function

Initiates a defrost cycle.

All other functions are disabled including alarm(s) enabling

Show Room Setting

Activation

Press and hold Fresh Food Temperature UP (WARMER) Key while pressing the fresh food temperature DOWN (COLDER) key 3 times within 5 seconds. Both displays will flash "0" for 10 seconds. While the displays are flashing, press the Freezer Temperature UP key to confirm activation.

Change Between Fahrenheit and Centigrade

To change form Fahrenheit to Centigrade press and hold the fresh food up key. At the same time press the Freezer up key 3 times in 5 seconds.

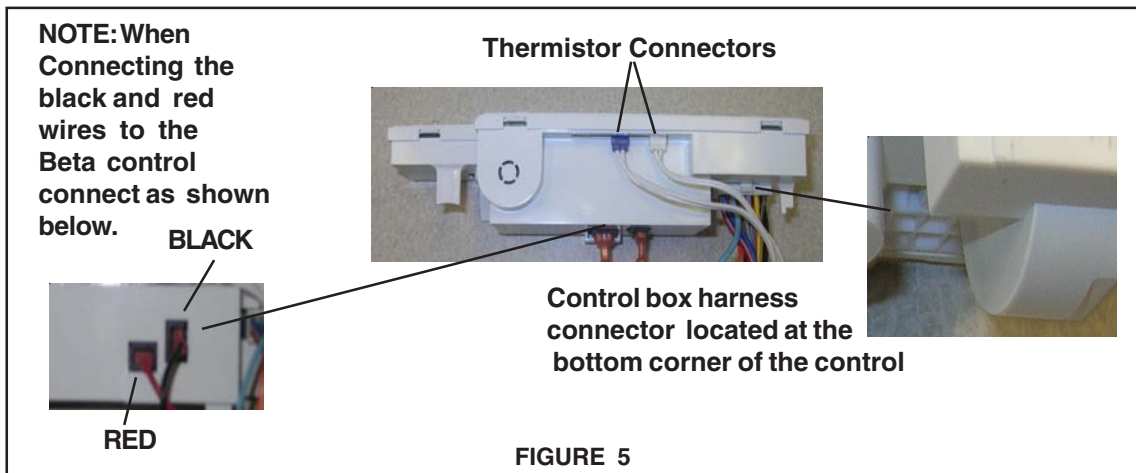

DAMPER

The damper used with the Beta control only has one switch, located next to the foam insulation on the damper housing. The electrical mechanical control and the Genesis uses a damper with two switches.

The Beta control can be used to replace a Genesis but you will need to replace the control box wiring harness. The damper switch located next to the motor will not be used with a Beat control. The Beta control is slightly larger than the Genesis but it will mount in the same control box. (See Figure 6)

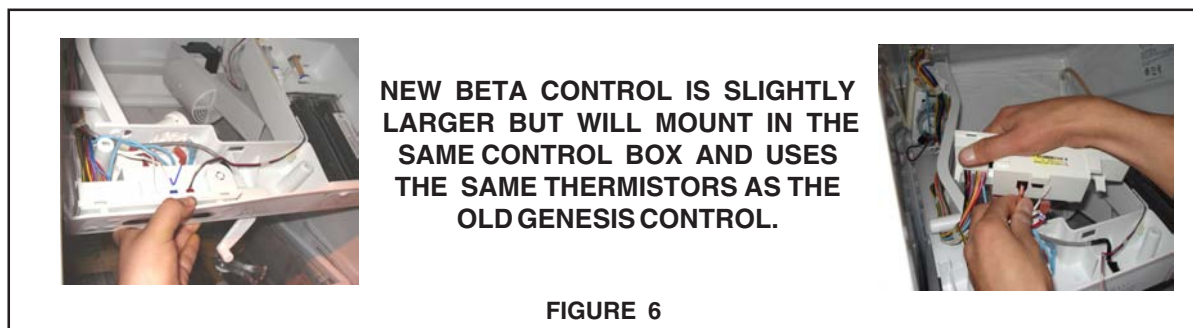

SECTION D - AIR CIRCULATION

AUTOMATIC DEFROST MODELS

Principals Of Automatic Defrost Operation

Automatic defrost refrigerators operate on the principle that moisture or frost transfers or migrates to the coldest surfaces (evaporator) in the freezer compartment. For example, a small amount of water spilled in the freezer compartment will freeze immediately. However, this ice in time will evaporate and transfer to the colder surfaces of the freezer evaporator coil.

Air Circulation Patterns

Automatic defrost models have a single evaporator in the freezer compartment, and have forced air cooling in the freezer and refrigerator compartments.

The “fin and tube” aluminum type evaporator is located on the lower back wall of the freezer compartment. A circulating fan (suction type) pulls air from the freezer compartment through the grill in the bottom of the freezer and from the refrigerator compartment through a duct located in the separating wall in the bottom rear left hand corner of the cabinet interior. The air is then drawn up through the fin and tubes of the evaporator surface. The cold air is forced into a fan cover and discharged into the top of the freezer and out the air discharge under the ice maker. Figure D1. If the food compartment control in the top of the food compartment will open and allow cold air to enter the food compartment. If the food compartment calls for cooling but the fan is not running, the fan will start is soon as the damper is open and will continue to run as long as the food compartment control or the freezer control call for cooling.

The air circulating fan operates any time the food compartment control or the freezer compartment control call for cooling on ELECTRICAL MECHANICAL CONTROL models. On ELECTRONIC CONTROL the thermistors sense the temperature of the compartment and send the information to the electronic control. If the temperature in the food compartment is too warm the control will open the damper door and start the evaporator fan. If the freezer is too warm the control will start the compressor as well as the condenser and evaporator fan motors. During the defrost period, the compressor and circulating fan do not operate. The ADC (Adaptive Defrost Control) opens the electrical circuit to the fan motor and compressor on Electrical Mechanical Control models. The Electronic Control opens the electrical circuit to the fan motor and compressor on Electronic Control models.

ELECTRICAL MECHANICAL CONTROL

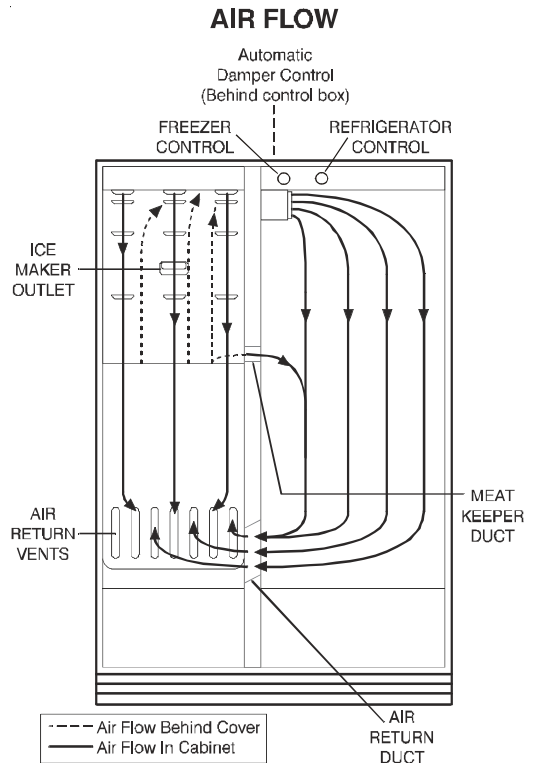
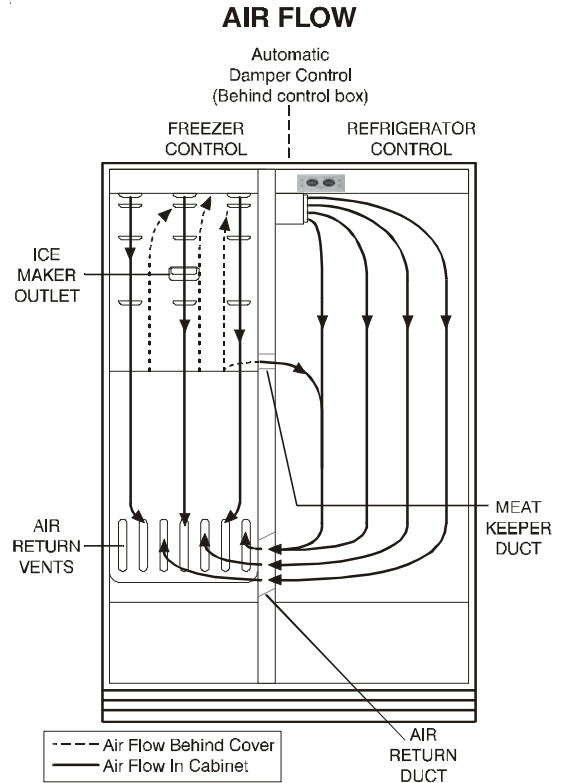

Figure D1

ELECTRONIC CONTROL



SECTION E - REFRIGERATION SYSTEM

NOTICE: Instructions given here are furnished as a guide. Persons attempting to use these instructions to make repairs to the sealed refrigeration system should have a working knowledge of refrigeration and previous training on sealed system repair, and an EPA certification for servicing refrigeration systems.

IMPORTANT NOTICE

Effective July 1, 1992, the United States clean air act governs the disposal of refrigerants such as R-134a. Therefore, when discharging or purging the sealed system use an epa approved refrigerant recovery system as outlined in the final rule on the protection of stratospheric ozone and refrigerant recycling, which was published in the Federal Register May 14, 1993.

NOTE: Frigidaire does not permit the use of recovered refrigerant in the servicing of our products for in-warranty and out-of-warranty repairs or for products covered by service contracts. Therefore, only new refrigerant or refrigerant that has been reclaimed back to new specifications by a refrigerant manufacturer is to be used.

DEFINITIONS

Recovery:

To remove refrigerant in any condition from a system and store it in an external container without necessarily testing or processing it in any way.

Recycling:

To clean refrigerant for reuse by oil separation and single or multiple passes through devices, such as replaceable core filter-driers, which reduce moisture, acidity and particulate matter. This term usually applies to procedures implemented at the field job site or at a local service shop.

Reclaim:

To reprocess refrigerant to new product specifications by means which may include distillation. Will require chemical analysis of the refrigerant to determine that appropriate product specifications are met. This term usually implies the use of processes or procedures available only at a reprocessing or manufacturing facility.

SAFETY WARNINGS

Compressor Testing

Whenever testing a compressor, extreme caution should be used to prevent damaging the terminals. A compressor with a damaged terminal or a grounded winding can expel a terminal from its insulated housing when the compressor is energized. If this happens, a mixture of refrigerant and oil will be released that could be ignited by an external heat source (open flame, heater, etc.). Also, if there is air in the system when this happens, a spark at the compressor shell could ignite the refrigerant and oil mixture.

Charging Sealed Systems

Overcharging a refrigeration system with refrigerant can be dangerous. If the overcharge is sufficient to immerse the major parts of the motor and compressor in liquid refrigerant, a situation has been created which, when followed by a sequence of circumstances can lead to the compressor shell seam separating.

A hydraulic block occurs, preventing the compressor from starting. This condition is known as locked rotor. Electric current continues to flow through the compressor motor windings which become, in effect, electric resistance heaters. The heat produced begins to vaporize the excess refrigerant liquid causing a rapid increase in system pressure. If the compressor protective devices fail, the pressure within the system may rise to extremes far in excess of the design limits. Under these conditions, the weld seam around the compressor shell can separate with explosive force, spewing oil and refrigerant vapor which could ignite.

To eliminate this exceedingly rare but potential hazard, never add refrigerant to a sealed system. If refrigerant is required, evacuate the existing charge and recharge with the correct measured amount of the refrigerant specified for the system.

SOLDERING

WARNING: WEAR APPROVED SAFETY GLASSES WHEN WORKING WITH OR ON ANY PRESSURIZED SYSTEM OR EQUIPMENT. HAVE AN APPROVED DRY TYPE FIRE EXTINGUISHER HANDY WHEN USING ANY TYPE OF GAS OPERATED TORCH.

1. All joints to be soldered must have proper fit. Clearance between tubes to be soldered should be from .001" to .006". It is not practical to actually measure this; however, you do not want a dry fit or loose fit. Tubing joints should overlap about the distance of their diameter except for restrictor tubes, which should be inserted 1.25"
2. Clean all joint areas with fine steel wool or preferably an abrasive cloth, such as grit cloth No. 23 or Scotch-Brite.
3. Apply a thin film of liquid flux recommended for silver soldering to surfaces to be joined and to surfaces immediately adjacent to joint.
4. Align tubing so no stress is on joint. Do not move tubing while solder is solidifying or leaks will result.

CAUTION: During application of heat, use wet cloths to prevent heat from conducting to areas other than the soldered joint. Use a sheet of metal or torch guard pad as a heat deflector to keep flame away from inflammable materials and painted surfaces.

5. Use a torch of adequate capacity so joint can be quickly heated with a minimum of heat travel to other points. Use a good grade of silver solder.
6. Solder connections. If tubing is properly cleaned and fluxed, solder will flow readily. Use only enough solder to make a good bond.
7. Allow joint to cool, then wash exterior with water to remove flux.

BASIC COMPONENTS

The basic components of a refrigerator are a compressor, condenser, evaporator, heat exchanger (capillary tube and suction line), drier and perimeter hot tube.

PERIMETER HOT TUBE

To reduce the possibility of condensation forming on the exterior of the cabinet in high humidity areas, a perimeter hot tube (refrigerant tube) has been installed in the unit. The perimeter tube extends up the left side, across the top of the freezer and down the center mullion and into the filter drier. When the compressor operates, warm refrigerant flows through the primary condenser, then into the primary hot tube, warming the cabinet front exterior.

The perimeter hot tube is not replaceable. In the unlikely event of a leak in the hot tube, a kit is available to bypass the hot tube in the sealed system. A electrical heater wire must be installed within the tubing. Refer to the appropriate parts list of the model being serviced for the correct kit part number.

REFRIGERANT CYCLE

The refrigerant cycle is a continuous cycle that occurs whenever the compressor is in operation. Liquid refrigerant is evaporated in the evaporator by the heat that enters the cabinet through the insulated walls and by the heat from product load and door openings. The refrigerant vapor is then drawn from the evaporator, through the suction line to the compressor. Compression raises the pressure and temperature of the vapor in the compressor and the vapor is then forced through the discharge valve into the discharge line and into the condenser. Air passing over the condenser surface removes heat from the high pressure vapor which then condenses to a liquid. The liquid refrigerant then flows from the condenser to the evaporator through the small diameter liquid line (capillary tube). Before it enters the evaporator, the liquid refrigerant is sub-cooled in the heat exchanger by the low temperature suction vapor in the suction line.

LOW OR HIGH SIDE LEAK OR UNDERCHARGE

A loss of refrigerant can result in any of the following:

1. Excessive or continuous compressor operation.
2. Above normal freezer and /or food compartment temperature.
3. A partially frosted evaporator (depending on amount of refrigerant loss).
4. Low suction pressure (vacuum).
5. Low wattage.

The condenser will be "warm to cool", depending on the amount of refrigerant lost.

When refrigerant is added, the frost pattern will improve, the suction and discharge pressures will rise, the condenser will become hot and the wattage will increase.

In the case of a low side refrigerant leak resulting in complete loss of refrigerant, the compressor will run but will not refrigerate. Suction pressure will drop below atmospheric pressure and air and moisture will be drawn into the system saturating the filter drier.

If there is reason to believe the system has operated for a considerable length of time with no refrigerant and the leak occurred in the evaporator, excessive amounts of moisture may have entered the system. In such cases the compressor may need to be replaced to prevent repetitive service.

If a slight undercharge of refrigerant is indicated and no leak can be found after a thorough leak test, the charge can be corrected without changing the compressor.

If a high side leak is located and some refrigerant remains in the system it is not necessary to change the compressor.

TESTING FOR REFRIGERANT LEAKS

If the system is diagnosed as short of refrigerant and the system has not been recently opened, there is probably a leak in the system. Adding refrigerant without first locating and repairing the leak or replacing the component will not permanently correct the difficulty. **The leak must be found.** Sufficient refrigerant may have escaped to make it impossible to leak test effectively. In such cases, add a ¼" line piercing valve to the compressor process tube. Add sufficient refrigerant vapor to increase the pressure to 40 to 50 lb. per sq. in. Check the low side for leaks. Run the compressor 2 or 3 minutes and check the high side for leaks. Recover refrigerant using an EPA approved recovery system.

NOTE: The line piercing valve (clamp-on type) should be used for test purposes only. It must be removed from system after it has served its purpose.

CHECKING FOR INTERNAL (HOT TUBE) LEAKS

Before checking for internal leaks, check all accessible system components and joints for leaks.

If an internal hot tube leak is suspected, it must be confirmed. Use the following procedure:

1. Recover refrigerant by using EPA approved recovery system.
2. After *system refrigerant* is completely recovered, disconnect drier from hot tube. Pinch off and solder end of hot tube closed.
3. Cut line from condenser to hot tube and solder a ¼" charging hose fitting to open end of hot tube or put compression fitting on tube.
4. Connect pressure gauge and access valve to hot tube and pressurize to 250 psig using dry nitrogen or carbon dioxide.

WARNING: NEVER PRESSURIZE WITH OXYGEN. NEVER OPEN A HIGH PRESSURE TANK UNLESS IT IS EQUIPPED WITH A PRESSURE REGULATOR. NEVER PUT HIGH PRESSURE ON DOME OF COMPRESSOR—IT COULD EXPLODE. MAKE SURE GAUGE, HOSES, AND ALL FITTINGS ARE IN GOOD CONDITION AND DO NOT LEAK.

5. Leave pressure on hot tube for 24 hours. Any drop in pressure is indication of leak.

If dry nitrogen or carbon dioxide is not available, follow steps 1 through 3 above, then steps 4 and 5 below:

4. Connect gauges to charging hose fittings. Pull vacuum on hot tube.
5. Leave vacuum on each side of system for 24 hours. Any loss of vacuum indicates leak.

COMPRESSOR REPLACEMENT

CAUTION: NEVER install a new compressor without first checking for possible system contamination.

To check for contamination, obtain oil sample from old compressor.

- If the oil has burned odor, but no color change or residue — follow instructions in section *“Installing A New Compressor on page 24”*.
- If oil has a burned odor and a sugar or gritty feel as well as showing signs of contamination (dark color) — follow instructions in next section, *To Flush The System*. Remove as much of contamination as possible from system before installing new compressor and filter-drier.

To Flush The System

NOTE: It is recommended that system be flushed with dry Nitrogen. However, if refrigerant is used to flush the system you must look at the serial plate to see what type of refrigerant is used in the system. This is the only refrigerant that can be used to flush the system and it must be recovered.

CAUTION: Use extreme care when using Dry Nitrogen to flush systems. Pressure in nitrogen cylinder could be as high as 2000 psi. Nitrogen cylinder must be equipped with approved pressure regulator and pressure relief valve. Ensure that your hoses have adequate ratings for pressure involved and that all of your equipment is in good condition.

CAUTION: The end of the flushing hose on this tank regulator must be equipped with a hand shut-off valve (Robinair No. 40380). Close hand shut-off valve and adjust nitrogen regulator to correct pressure before proceeding with flushing procedure.

To Use Dry Nitrogen To Flush The System:

1. Remove compressor and filter-drier. Connect process coupling to outlet tube of condenser.
2. Fasten cloth over other end of coil to prevent old oil from spraying over room.
3. Connect hand shut-off valve on flushing hose to process coupling.
4. Slowly open hand shut-off valve and allow nitrogen to flow through condenser until discharge is clear.

CAUTION: DO NOT exceed 300 PSIG.

5. Disconnect cap tube from evaporator. Flush evaporator in same manner as condenser.

CAUTION: DO NOT exceed 150 PSIG.

6. Flush cap tube. This is only possible if you have proper service valve adaptor.

CAUTION: DO NOT exceed 300 PSIG.

7. Reassemble system.

To Use Refrigerant To Flush The System:

CAUTION: Refrigerant used for flushing must be recovered into a recovery system. Meter amount of refrigerant used for flushing with your charging cylinder. DO NOT OVERFILL THE SYSTEM.

1. Disconnect the suction and discharge lines from the compressor and remove the filter-drier. Connect process coupling to outlet and inlet tube of condenser.
2. Connect hose to outlet process coupling and charging cylinder. Connect another hose to inlet coupling and recovery system.
3. Open charging cylinder and allow refrigerant to flow through condenser until discharge into bag is clear.

NOTE: To flush evaporator and heat exchanger you must remove evaporator from inside product to disconnect cap tube.

4. Disconnect capillary tube from evaporator. Flush evaporator in same manner as condenser.
5. Flush cap tube. This is only possible if you have proper service valve adaptor.
6. Reassemble system.

Installing a New Compressor

NOTE: Entirely new compressors have been developed for use with R-134a and Ester oil refrigeration systems. Both compressor and electric motor have been modified. Old compressors intended for R-12 refrigerant must not be used for new systems charged with R-134a.

Replacement of compressor and installation of filter-drier must be done in a continuous sequence so system is exposed to atmosphere no longer than necessary.

All replacement compressors are shipped with rubber plugs in the suction, discharge and process tubes and contain the correct oil charge and a holding charge of inert gas. Compressors have a low-side process tube attached to the compressor shell. A high-side process tube is attached to the filter-drier.

WARNING: DO NOT OPERATE RECIPROCATING COMPRESSOR WHEN CHARGING LIQUID REFRIGERANT INTO SYSTEM THROUGH ITS PROCESS TUBE.

Replacement compressors for refrigerator may have an oil cooler even if the original compressor did not. If the product is not equipped for an oil cooler, leave the plastic caps in place and install the compressor connecting only to the suction and discharge lines of the new compressor.

Before installing the replacement compressor remove the discharge plug and check for the pop sound of the inert gas leaving the compressor.

CAUTION: DO NOT use compressor if you do not hear this sound.

If the compressor checks OK, reinstall the plug. Do not remove any of the plugs again until the compressor is in position and you are ready to braze the lines.

CAUTION: On R-134a systems, compressor must NOT be left open to atmosphere for more than 10 minutes to prevent moisture contamination of oil.

A new compressor which is cold (e.g. after having been kept in a cold service van) should be left to warm to the surrounding temperature before the plugs on the compressor connections are removed. This will help prevent condensation from forming in the oil and the compressor. Also, avoid opening the system when any of the components or lines are cold.

NOTE: Release holding charge (release slowly to avoid oil discharge) on new compressor to ensure there is no leak in seam or tubing. Reinstall rubber plug.

1. Disconnect electrical supply to refrigerator.
2. Remove compressor access panel.
3. Recover refrigerant by using EPA approved recovery system.
4. Remove condenser fan mounting screws.
5. Unplug fan motor harness located in back of fan motor.
6. Remove fan motor and fan blade.
7. Remove leads from compressor motor terminals.
8. Remove mounting clips and washers.

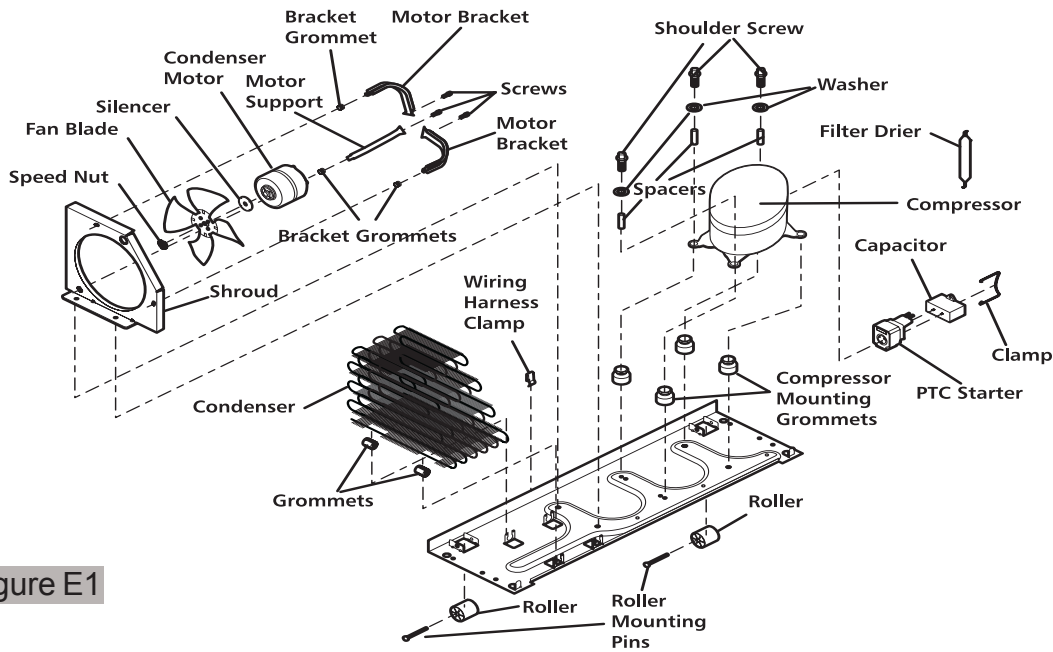

Figure E1

9. After refrigerant is completely recovered, cut suction and discharge lines as close to compressor as possible. Leave only enough tubing to pinch off and seal defective compressor. Plug or tape any open system tubing to avoid entrance of moisture and air into system. Remove inoperable compressor and transfer mounting parts to new compressor.
10. Install new compressor in exact same manner as original compressor.
11. Reform both suction and discharge lines to align with new compressor. If they are too short, use additional lengths of tubing. Joints should overlap 0.5" to provide sufficient area for good solder joint. Clean and mark area where tubing should be cut. Cut tubing with tubing cutter. Work as quickly as possible to avoid letting moisture and air into system.

NOTE: If low-side process tube is too short, silver solder four inch piece of tubing onto process tube at this time.

12. Solder all connections according to soldering procedure outlined on page 21.
13. Remove original filter-drier.

CAUTION: DO NOT unbraze old filter-drier from system. This will vaporize and drive moisture from desiccant back into system. The old filter-drier should be cut out of system.

14. Install new filter-drier at condenser outlet.
15. Evacuate and charge system using recommended procedure described under Evacuating and Recharging.

16. Reconnect compressor terminal leads in accordance with refrigerator wiring diagram.
17. Reassemble unit.

EVAPORATOR REPLACEMENT

CAUTION: Always use the TORCH GUARD heat shield part number 5304418872, behind evaporator before attempting to solder. The excessive heat from soldering will warp the plastic liner.

The evaporator is located in the lower section of the freezer and is secured to the drain pan by a bracket at the top. Styrofoam blocks are located on each side, directly across from each other to ensure proper air flow through the evaporator.

The heat exchanger on this style of refrigerator is in the insulation between the food liner and the cabinet back. You will not be able to remove the heat exchanger with the evaporator. Because of this, all line welds will be made inside the freezer. The evaporator kit contains a heat shield to protect the liner from damage when brazing.

Evaporator Kit Contains:

1 Evaporator	1 Heat Shield
1 Drier-Filter	1 Instruction Sheet

1. Disconnect refrigerator from electrical supply.
2. Remove all freezer section shelves and baskets.
3. Remove bottom evaporator cover.
4. Disconnect wiring harness at liner plug. Remove defrost limiter and disconnect defrost heater. (See Figure 1)

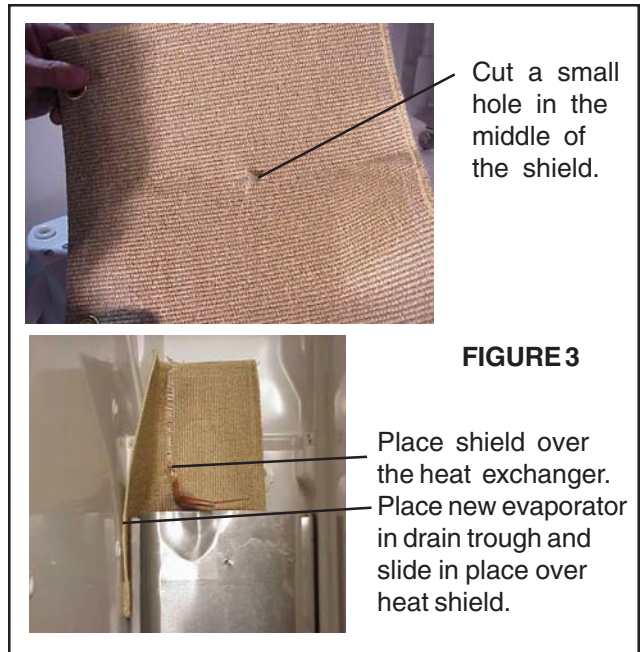
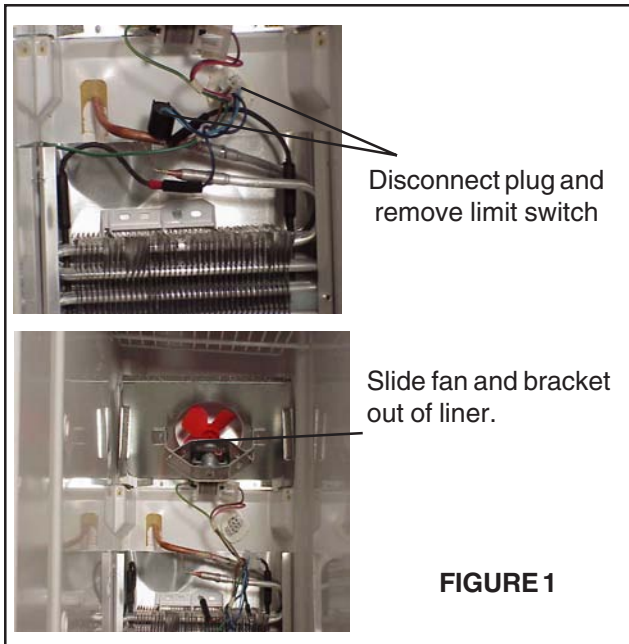

5. Cut suction line in front of weld at evaporator. Using a file, score and break the cap tube just in front of the weld. (See Figure 2.)

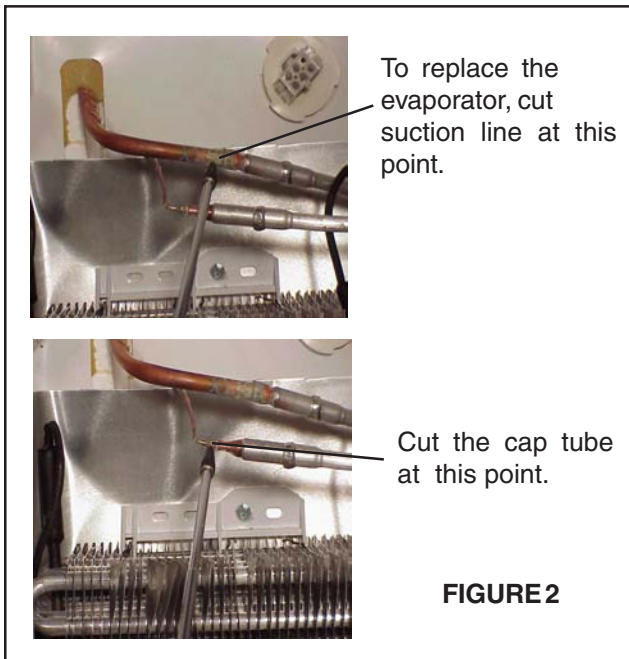

9. Remove rivet in retainer at top of old evaporator. Slide evaporator out top of drain trough.
10. Transfer defrost heater from old evaporator to new evaporator, then slide evaporator into top of drain trough.
11. Slide evaporator and drain trough in place and push drain trough over heat shield. This will help hold shield in place. (See Figure 3.)
12. Place cap tube in new evaporator and weld in place.
13. Place suction line in new evaporator and weld in place.

6. Remove drain trough and evaporator from inside the freezer.
7. Clean end of suction line and cap tube. Straighten line and slightly bend toward front of cabinet to aid in installing shield.
8. Cut a small "X" in heat shield, then slide cap tube and suction line through hole. Pack heat shield in back corner of liner. (See Figure 3.) **Note:** You may need to use a small pair of vise-grips on the suction line to help hold the heat shield in place.

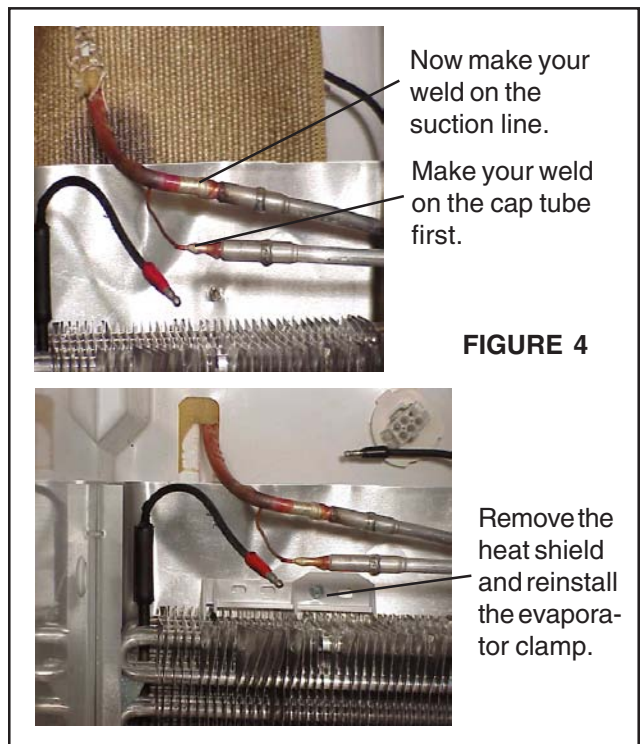

14. With a sharp knife, cut along a seam on the heat shield from center hole to edge of shield. Slide shield from between liner, drain trough and suction line assembly.
15. Push evaporator back in place and reinstall plastic clamp at top. (See Figure 4.)
16. Slide fan and bracket assembly in place and connect defrost heater. Mount limit switch on evaporator. Plug wiring harness into connector on liner.
17. Replace Drier-Filter. Pump down and recharge system.
18. Allow product to run and make sure refrigerant is circulating. Reinstall evaporator cover and machine compartment cover.

HEAT EXCHANGER REPLACEMENT

CAUTION: Always use the TORCH GUARD heat shield behind evaporator before attempting to solder. The excessive heat from soldering will warp the plastic liner.

The original heat exchanger (Suction Line & Cap Tube Assembly) in this product is enclosed in the insulation between the liner and the cabinet back. Because of this, the original part can not be removed. There is a service kit to bypass the internal heat exchanger. It will be necessary to run a new heat exchanger down the back of the product and bypass the internal heat exchanger.

Heat Exchanger Kit Contents:

1 Heat Exchanger	6 Screws
1 Drier-Filter	1 Cover
1 Armor Flex	1 Package Permagum
2 Tape	1 Instruction Sheet

To replace the heat exchanger:

1. Recover refrigerant from sealed system.
2. Disconnect wiring harness at liner plug.
3. Remove defrost limiter and disconnect defrost heater.



Cut suction line off at liner. Remove evaporator and save for reuse.

FIGURE 1

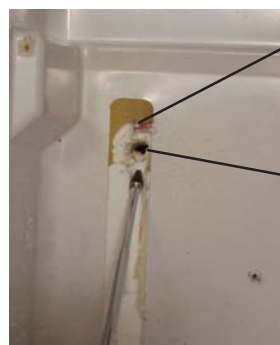

Old Heat Exchanger Location

Drill 1/2 inch hole through cabinet 1 inch below old Heat Exchanger.

FIGURE 2

4. Remove fan motor and wiring.
5. Cut heat exchanger off flush with liner. (See Figure 1.)
6. Remove evaporator and drain trough. **NOTE:** You do not need to remove rivet or defrost heater.
7. Using a 1/4" drill bit, drill hole through cabinet from inside at location shown in Figure 2.
8. Using a 1/2" drill bit, open hole drilled in Step 7 to 1/2" from back of product. (See Figure 2.)
9. Remove stubs of old heat exchanger from evaporator and install new heat exchanger into evaporator.
10. Push heat exchanger through hole in cabinet (See



Push the heat exchange through the hole in the cabinet.

Install the armorflex over the heat exchanger. Seal hole using the permagum.

FIGURE 3



Using screws in kit, attach cover to back of cabinet. Line lower cover up with top of machine compartment opening

FIGURE 4



Using the permagum provided in kit, seal hole and end of old heat exchanger.

FIGURE 5



Using the permagum provided in kit, seal hole and end of old heat exchanger.

FIGURE 6

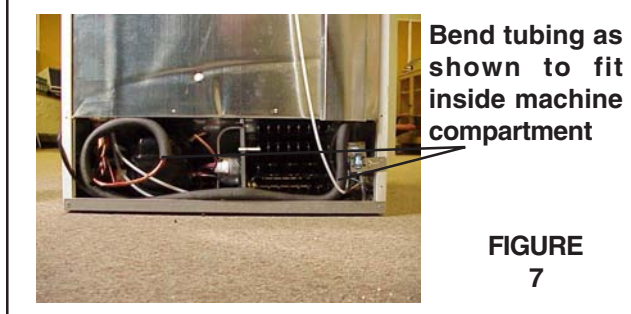

Bend tubing as shown to fit inside machine compartment

FIGURE 7

- figures 3 & 5.) and set evaporator back in place.
11. Slide Armor-Flex over heat exchanger until cover is against hole at back of cabinet. The excess cap tube can be wound around the suction line.
 12. Seal the hole on the inside and outside using Permagem. (See Figures 3 & 5)
 13. The one piece cover can now be installed over heat exchanger. Place open end of cover with top of compressor compartment opening. Attach cover to back of cabinet using screws provided. There is no need to predrill holes as the screws are self cutting. (See Figure 4.)
 14. Seal hole and end of old heat exchanger with Permagem. (See Figure 6.)
 15. Replacr Drier-Filter.
 16. Evacuate and recharge system.
 17. Bend remaining tubing to fit into machine compartment opening, being careful not to set up any excess noise from line vibration. (See Figure 7.)
 18. Run product to make sure refrigerant is circulating.
 19. Reinstall evaporator and machine compartment cover.

PERIMETER HOT TUBE REPAIR KIT

Effective July 1, 1992, Section 608 of the **Clean Air Act** prohibits Individuals from knowingly venting ozone depleting compounds used as refrigerants into the atmosphere while maintaining, servicing, repairing, or disposing of refrigerant equipment.

A hot tube repair kit is used to bypass a leaking Perimeter Hot Tube (Yoder-Loop). The Perimeter Hot Tube must be bypassed in the sealed refrigeration system and a low wattage heater wire installed inside the tube. This heater will prevent condensation from forming on the exterior front edge of the cabinet.

Hot Tube Heater Kit Contants:

1	Copper Bypass Tube	1	Plastic Sleeve
1	Drier-Filter	1	Heater Wire
3	Clamps	1	Harness Adapter
3	Screws	2	Wire Connectors

BYPASSING PERIMETER HOT TUBE - STEP 1

1. Disconnect service cord from power supply.
2. Recover refrigerant from system.
3. Remove filter-drier.
4. Using tubing cutter, cut and de-burr tubing from perimeter hot tube at points shown in figure below.

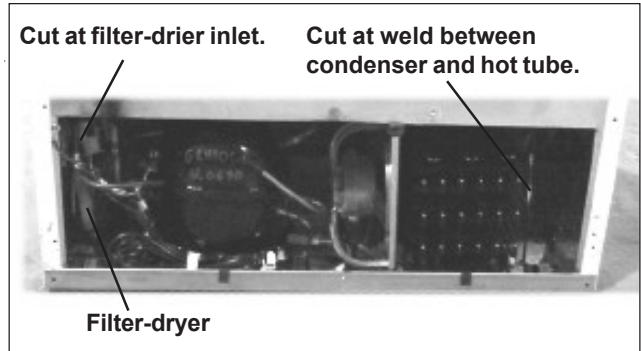

5. Install copper bypass tube and replacement filter-drier as shown in figure below. Use 45% silver solder for all connections.

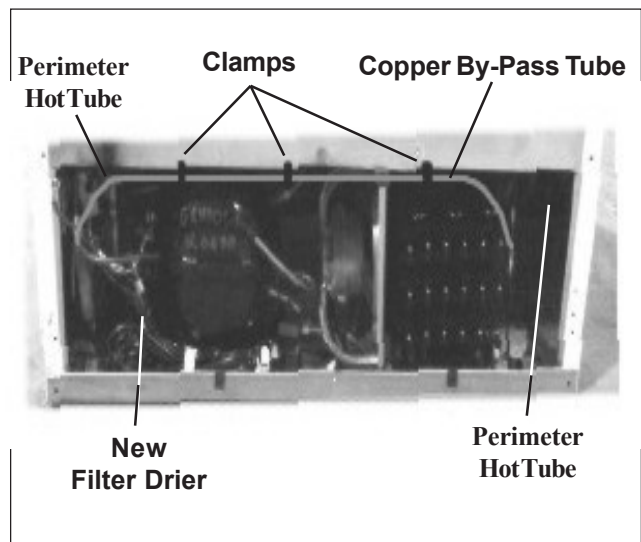

6. Drill or pierce three holes in cabinet to hold clamps. Secure by-pass tube just below cabinet edge with three clamps and screws provided.

NOTE: When clamped in place the by-pass tube should NOT touch any plastic lines, such as water lines for ice makers and/or filters as well as drain lines.

7. Evacuate and recharge refrigeration system. Refer to serial plate for correct charge.

INSTALLING THE HEATER WIRE - STEP 2

1. Attach Vacuum Pump and Gauge Set to one end of Perimeter Hot Tube with an Adapter and Plastic Sleeve. See illustration on next page.
2. Cutoff waxed end of Fiberglass braid that is extended past end of heater wire and make knot in end just a little smaller than inside diameter of hot tube.
3. Insert knot on end of braid into open end of Perimeter Hot Tube.
4. With braid inserted, start Vacuum Pump and place your thumb over end of tube. When good vacuum is obtained, release your thumb and begin to feed braid into Hot tube. Continue this process until string reaches Plastic Sleeve.

NOTE: Take the time to remove all the bends from the heater (caused from being rolled up) by pulling the heater and braid through a shop rag with a small amount of silicone on the rag and laying it in a roll at the open end of the Hot Tube. It will make heater installation go faster. Using of a good two stage, 5 CFM Vacuum Pump will also make heater installation go faster.

5. Disconnect Plastic Sleeve.
6. Pull braid out while pushing equal amount of braided heater into tube at other end until heater wire inside braid appears.

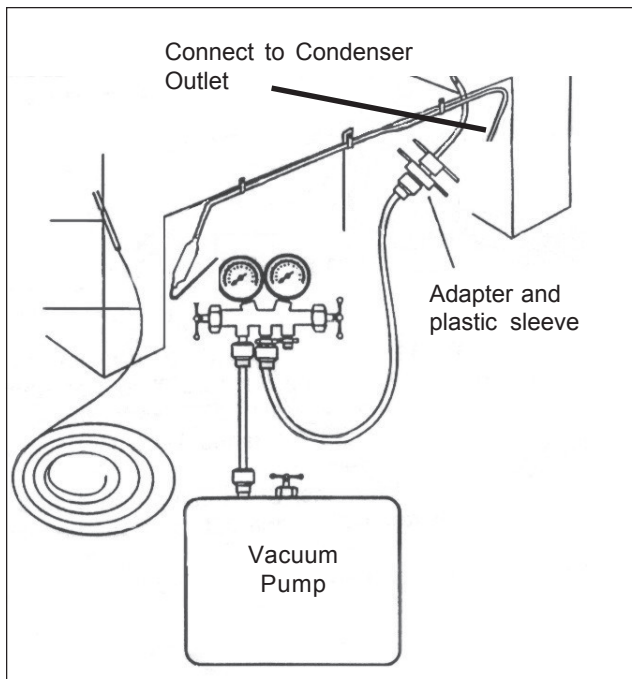

INSTALLING THE HEATER WIRE - STEP 3

1. Remove wires (with terminals) from compressor starter/overload. On some models you will need to depress locking tabs located in relay housing (See Drawing below.)

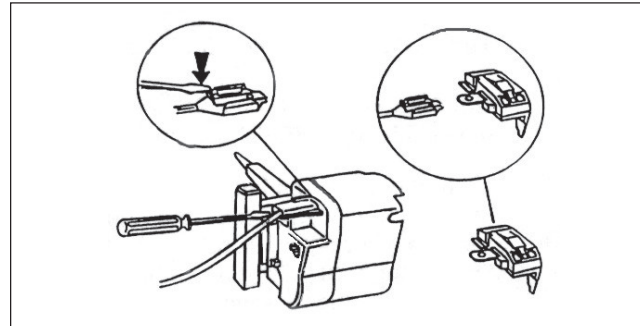

2. Install harness adapter into refrigerator circuit as shown below.

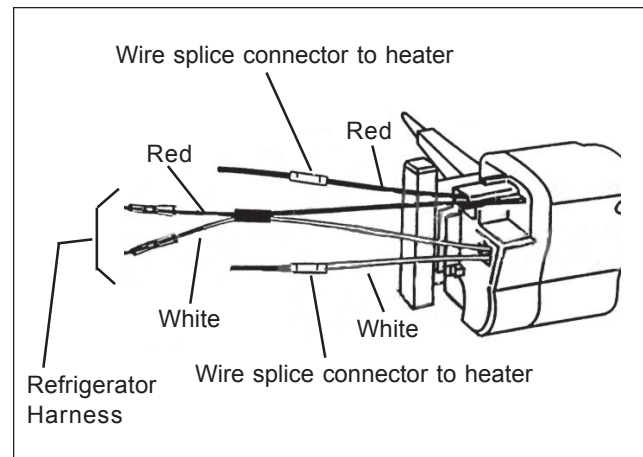

3. Cut off braid at start of heater. Strip insulation back about 5/16 inch. Be careful not to damage heater resistance wire. Splice heater wire ends to loose leads of adapter harness with furnished wire connectors.
4. Dress wires away from Condenser Fan Blade and any sharp edges.
5. Secure wires with electrical tape as necessary.
6. Reinstall Back Panel for proper air flow over condenser and compressor.

CONDENSER REPLACEMENT

1. Disconnect electrical supply to refrigerator.
2. Remove compressor access panel.
3. Recover refrigerant by using EPA approved recovery system.
4. Remove condenser fan mounting screws.
5. Unplug fan motor harness located in back of fan motor.
6. Remove fan motor and fan blade.
7. After refrigerant is completely recovered, disconnect inlet and discharge lines from condenser.
8. Remove white condenser retainer clip from fan bracket and condenser.
9. Lift front of condenser and the two rubber grommets out of retainer in base plate.
10. Remove old condenser out the back of cabinet.
11. Install replacement condenser.
12. Remove original filter-drier.

CAUTION: DO NOT unbrazed the old filter-drier from the system. This will vaporize and drive moisture from the desiccant back into the system. The old filter-drier should be cut out of the system.

13. Install new filter-drier at condenser outlet.
14. Evacuate and charge the system using recommended procedure described under Evacuating and Recharging on pages 27-28.
15. Reassemble unit.

FILTER-DRIER INSTALLATION

Any time the sealed system is opened and the refrigerant charge is removed, the liquid line filter-drier must be replaced and the system thoroughly evacuated before recharging.

CAUTION: DO NOT unbrazed the old filter-drier from the system. This will vaporize and drive moisture from the desiccant back into the system. The old filter-drier should be cut out of the system.

CAUTION: Use only a 15 gram XH9 liquid line filter-drier (part number 5303305677) when servicing refrigerator and freezer systems. This filter-drier is compatible with either R-12 or R-134a refrigerant.

1. Disconnect unit from source of power.
2. Recover refrigerant by using an EPA approved recovery system.
3. Using a 3 cornered file, score a groove around capillary tube as close to old filter-drier as possible. Break capillary tube along score mark from filter-drier.
4. Cut condenser outlet tube at filter-drier. Discard filter-drier.

5. Thoroughly clean condenser outlet tube and capillary tube.
6. Place inlet connection of filter-drier over condenser tube approximately 1/4" and solder.
7. Insert capillary tube input end into filter-drier outlet. Do not allow tube to bottom against screen. Solder carefully so that solder does not plug capillary tube.
8. Install process tube adaptor to filter-drier.
9. Evacuate and charge system using the recommended procedure described under Evacuating and Recharging on pages 27-28.
10. Reassemble unit.

EVACUATING AND RECHARGING

CAUTION: Check the serial plate for the correct refrigerant type. It is extremely important to verify the type of refrigerant in the system before starting any sealed system repairs.

CAUTION: With the possible exception of the vacuum pump, all service equipment that comes in contact with R-134a during evacuation and recharging must be dedicated. Accordingly, R-134a will require a dedicated charging cylinder, manifold gauge set, process tube adaptors, and hoses. Any residual mineral oil on other tools (tubing cutter, etc.) must be thoroughly cleaned off before using on R-134a/Ester oil systems. It will be necessary to check with the manufacturer of your vacuum pump for refrigerant and oil compatibility issues.

CAUTION: If you use a vacuum pump with mineral oil to evacuate an R-134a system, it is ABSOLUTELY ESSENTIAL to have a shut-off valve between the pump and your manifold gauge set as shown on page 32, Figure E2. The hand valve must be closed during all times when the vacuum pump is not operating. This will prevent the migration of mineral oil vapor into the R134a/Ester oil system. If the vacuum pump should stop during evacuation for any reason, the hand pump shut-off valve must be closed immediately.

CAUTION: Insure that your refrigeration hoses are specified for use with R-134a refrigerant. Research has shown that compounds in standard refrigeration hoses may enter sealed systems and ultimately restrict the cap tube in an R-134a system.

Equipment Needed for Evacuation & Recharging:

- Heated charging cylinder
- Standard 3-port manifold gauge set:
 - 4 charging hoses
 - Tee fitting with valve core stem removed (Robinair No. 40396)
 - Hand shut-off valve (Robinair No.40380)
- Two stage vacuum pump
- Process tube adapter kit (Robinair No. 12458)
- Tubing cutter
- Pinch-off tool capable of making leak proof seal
- Complete brazing torch set
- Small 3-corner file
- Grit cloth or Scotch-Brite
- 45% silver solder and flux
- Heat Gun

Installing Evacuation and Recharging Equipment

1. Disconnect refrigerator from electrical supply.
2. If compressor was replaced, install correct sized process tube adaptor on process tube. If compressor was not replaced, cut process tube with tubing cutter leaving as much tube as possible and install correct size process tube adaptor.
3. Install correct sized process tube adaptor on high-side process tube.
4. Attach refrigeration service gauge manifold to system in following order:
 - Low-side (compound gauge) hose to suction side process tube adaptor.
 - High-side (pressure gauge) hose to high-side process tube adaptor.
 - Center port manifold hose before hand shut-off valve to charging cylinder.
 - Center port manifold hose after hand shut-off valve to vacuum pump.

Evacuating System

WARNING: R-134A SYSTEMS ARE PARTICULARLY SUSCEPTIBLE TO MOISTURE CONTAMINATION WHICH CAN ONLY BE PREVENTED BY EVACUATING THE SYSTEM FOR A MINIMUM OF 30 MINUTES TO ATTAIN A MINIMUM 29.9 INCH (500 MICRON OR LOWER) VACUUM.

To achieve the required levels of evacuation, a properly maintained two stage vacuum pump in good condition is required. It is absolutely essential to maintain your vacuum pump according to the manufacturer's instructions including required oil changes at the recommended intervals. Vacuum pump oil should always be changed after evacuating a contaminated system.

Vacuum pump performance should be checked periodically with a micron gauge.

1. Make certain that charging cylinder valve, hand shut-off valve, and manifold gauge valves are closed.

2. Start vacuum pump.
3. Open hand shut-off valve and slowly open both manifold valves, turning counterclockwise, for two full rotations.

CAUTION: If high vacuum equipment is used, just crack both manifold valves for a few minutes and then open slowly for the two full turns counterclockwise. This will prevent the compressor oil from foaming and being drawn into the vacuum pump.

4. Operate the vacuum pump for a minimum of 30 minutes to a minimum of 29.9" (500 micron) vacuum. **NOTE:** On products with Low side leaks you must heat the crankcase area of the compressor though out the 30 minutes you are running your vacuum pump to pull a vacuum on the system. Every 4 to 5 minutes while you are running your vacuum pump and heating the crankcase area shake the compressor. By heating the crankcase you are heating the oil in the compressor. This will drive the moisture out of the oil. By shaking the compressor this will allow the moisture to come to the top of the oil faster so the vacuum pump can remove the moisture from the system.
5. Close hand shut-off valve to vacuum pump. Watch compound gauge for several minutes. If reading rises, there is a leak in the system, go to step 6. If no leak is indicated, stop vacuum pump. System is now ready for charging.
6. If a leak is indicated, stop vacuum pump and introduce a small charge of refrigerant into system by cracking valve on bottom of charging cylinder until system is pressurized to 40 or 50 lbs psig.
7. Leak test low-side. Close compound gauge. Run compressor for a few minutes and leak test high-side. When leak is found, recapture refrigerant using EPA approved recovery system Repair and go back to step 1.

Charging The System

CAUTION: Check the serial plate for the correct refrigerant type. It is extremely important to verify the type of refrigerant in the system before starting any sealed system repairs.

CAUTION: After charging the system with liquid be certain to wait at least 5 minutes before starting the compressor to give the refrigerant a chance to disperse throughout the system. Otherwise the compressor could be damaged by attempting to pump excessive quantities of liquid.

Preparing The Charging Cylinder:

1. Make certain that hand shut-off valve to vacuum pump is closed.
2. Close high-side manifold gauge valve.
3. Set charging cylinder scale to pressure indicated on cylinder pressure gauge.
4. Observe refrigerant level in sight glass. Subtract amount to be charged into system and note shut off point.
5. Open charging cylinder valve slowly and allow proper charge to enter system.
6. As soon as refrigerant in sight glass has gone down to predetermined level, close charging cylinder valve.

WARNING: DISCONNECT THE CHARGING CYLINDER HEATER AT THIS TIME TO PREVENT THE CYLINDER PRESSURE FROM EXCEEDING ITS MAXIMUM LIMITS.

7. Allow system to sit for five minutes.
8. Turn on refrigerator compressor. Run compressor for a few minutes and monitor system pressures.
9. When satisfied that the unit is operating correctly, clamp the high-side process tube with the pinch-off tool while the unit is still running.

10. Slowly open the high-side manifold gauge valve to allow the compressor to remove any refrigerant trapped in the high-side hose and the process fitting.
11. Close both of the manifold gauge valves. If the high-side gauge reading rises, the pinch-off must be corrected before proceeding.
12. Remove the high-side process tube adaptor and solder the process tube closed.
13. Clamp the low-side process tube with the pinch-off tool while the unit is running. Remove the low-side process tube adaptor and solder the process tube closed.
14. Check the process tubes for refrigerant leaks.

NOTE: Process valves are not to be left on the tubing in any application, except the valve on EMA Service drier part # 5303918288.

FINAL LEAK TEST

1. With the refrigerator turned OFF leak test all low-side system components.
2. Turn the unit ON and run until the condenser is warm. Leak test the high-side system components.

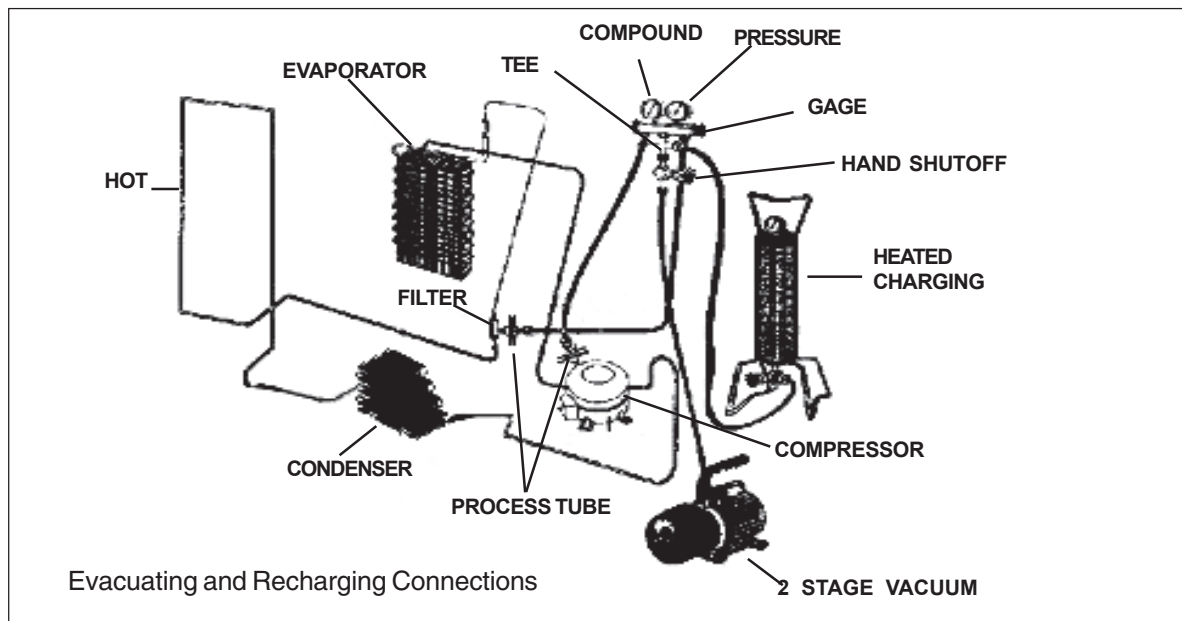

R-134a SERVICE INFORMATION

NOTICE: Instructions given here are furnished as a guide. Persons attempting to use these instructions to make repairs to the sealed refrigeration system should have a working knowledge of refrigeration and previous training on sealed system repair.

VERIFY REFRIGERANT TYPE IN THE SYSTEM

CAUTION: R-134a and R-12 are completely incompatible. Before starting any sealed system repair, it is extremely important to check serial plate of product to verify the type of refrigerant in the system.

Dedicated Equipment

R-134a must not be mixed with other types of refrigerants. R-134a must be recovered in dedicated and properly identified recovery bags and tanks.

It will be necessary to check with the manufacturer of your recovery equipment to determine R-134a compatibility. Some recovery equipment manufacturers have changeover instructions for switching between refrigerant types. Protect yourself and your equipment by following all manufacturer guidelines.

Also, ensure that your refrigeration hoses are specified for use with R-134a refrigerant. Research has shown that compounds in standard refrigeration hoses may enter sealed systems and ultimately restrict the cap tube in an R-134a system.

R-134a REFRIGERATION SYSTEMS

The sealed refrigeration system will consist of the same basic components being utilized in the R-12 systems.

There is a 10% to 15% discharge pressure increase using R-134a, with a 5% to 10% decrease in suction pressure when compared to the same product with an R-12 system operating at 90°F (32°C) ambient temperature conditions. Lower suction pressures result from the lower density of R-134a refrigerant which effects refrigerant flow rate. R-134a systems commonly operate in a 1"-2" vacuum on the suction side.

Products using R-134a refrigerant will generally have a longer capillary tube to maintain a similar flow rate and some models will have a larger condenser to reduce the discharge pressures and lower start-up sound transmission.

MISCIBILITY OF R-134a AND ESTER OIL

A special synthetic oil known as Ester oil is used as a lubricant in refrigeration systems operating on R-134a. Ester oils are produced from alcohols and fatty acids

and are available in several different variants. Ester oils have a pleasant aroma reminiscent of fruit.

Ester oils generally include various types of additives for improving certain properties such as viscosity, temperature sensitivity, etc. These additives are often aggressive, and skin contact with Ester oils should therefore be avoided.

One of the most important requirements made on a refrigerant system is that the oil mix with the refrigerant. Since mineral oil and ordinary synthetic oil DO NOT mix with R-134a, Ester oil is used for lubrication. Ester oil dissolves in R-134a.

Ester oil is broken down by chlorine and cannot be used with R-12 (R-12 contains chlorine) or any other compound containing chlorine. Therefore, R-134a refrigeration systems have virtually no tolerance for chlorine molecules from CFC refrigerants (R-134a is an HFC and contains no chlorine).

CAUTION: During R-134a service, it is extremely important to avoid using equipment that may contain residual amounts of mineral oil, CFC's or HCFC's which could enter and contaminate the sealed system.

For example, hoses that were used for a refrigeration system operating on R-12 may contain small quantities of mineral oil which can block the capillary tube in a system operating on R-134a. As little as one milligram may be sufficient to cause a blockage. In addition, sealed system components that have been used with CFC systems must not be used with R-134a systems. These components may contain residual amounts of refrigerant and oil which could damage an R-134a system.

At the earliest stage of development work on R-134a, tests were carried out on a different type of synthetic oil known as Poly-Alkaline Glycol (PAG). This oil is also used in certain air conditioning systems for cars. PAG and Ester oil DO NOT mix with one another. Service equipment used for R-134a / Ester oil must not come into contact with PAG.

WATER IN THE REFRIGERATION SYSTEM

Even in very small quantities, water in any refrigeration system can cause the following problems:

- Ice plugs in capillary tubes.
- Copper plating in compressor.
- Reactions with organic materials in systems.
- Corrosion of metals.

R-134a and Ester oil will aggravate the problem of water in the refrigeration system. Ester oil may react with water vapor and is hydroscopic (it will absorb water if it comes in contact with humid air). Water is also more soluble in R-134a than R-12.

To minimize the water content whenever service work is performed, the refrigeration system should always be thoroughly evacuated through process tube adaptors on both the high and low sides of the system. Evacuation must be for a minimum of 30 minutes to at least a 29.9 inch (500 micron) vacuum.

VACUUM CHART		
Vacuum Inches Hg.	Microns	Boiling Point of Water °F
28.940	25000	77.9
29.530	10000	52.0
29.832	4600	32.0
29.882	1000	1.0
29.901	500	-11.2
29.915	150	-32.8
29.917	100	-38.2
29.919	50	-49.0

To achieve the required 29.9 inch (500 micron) vacuum, a properly maintained two-stage vacuum pump in good condition is required. A two stage pump can reach a deeper vacuum than a single stage because the exhaust from the first pumping stage is discharged into the second pumping stage. This means the second stage begins pumping at a lower pressure so a lower ultimate vacuum can be achieved (See 2-Stage Vacuum Pump, Figure E3).

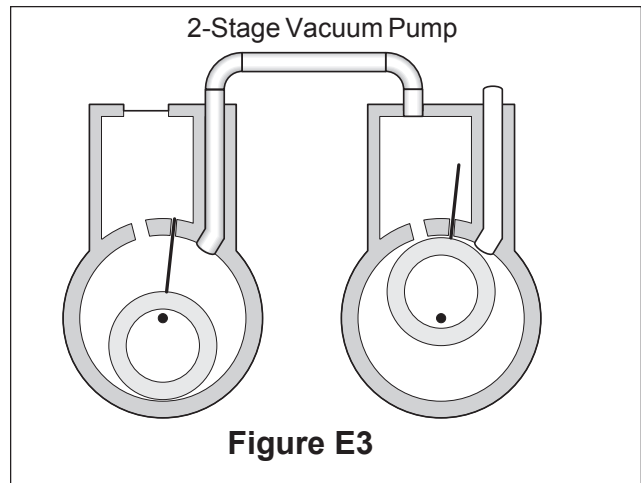

VACUUM PUMP MAINTENANCE

It is absolutely essential to maintain your vacuum pump according to the manufacturer's instructions including required oil changes at the recommended intervals. Vacuum pump oil should always be changed after evacuating a contaminated system. Vacuum pump performance should be checked periodically with a micron gauge.

Vacuum pump suppliers may or may not recommend changing the vacuum pump oil to the same type that's in the system being evacuated. Some manufacturers may recommend a vacuum pump that's dedicated to R-134a systems.

Robinair has stated that their current and discontinued vacuum pump models, using mineral oil currently specified for use in their vacuum pumps, can be used to evacuate R-134a/Ester oil systems. Robinair also states that it is acceptable to alternate between evacuating R-12/mineral oil and R-134a/Ester oil systems without adversely effecting the vacuum pump's performance.

For other brands of vacuum pumps, check with the manufacturer for restrictions and guidelines when using with R-134a.

CAUTION: If you use a vacuum pump with mineral oil to evacuate an R-134a system, it is ABSOLUTELY ESSENTIAL to have a shut-off valve between pump and your manifold gauge set as shown in Figure E4. The hand valve must be closed during all times when vacuum pump is not operating. This will prevent migration of mineral oil vapor into R134a/Ester oil system. If vacuum pump should stop during evacuation for any reason, the hand pump shut-off valve must be closed immediately.

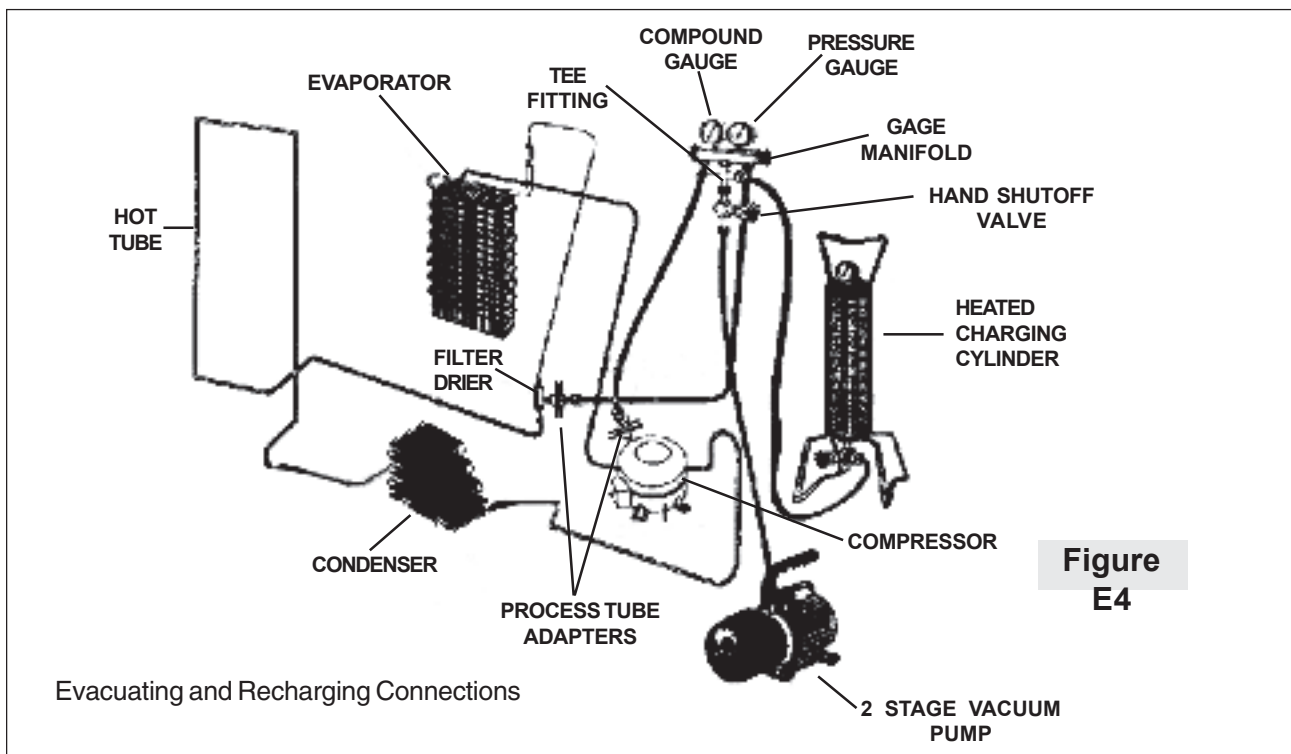

REFRIGERANT LEAKS

A system with R-134a and Ester oil will become saturated with moisture much faster than a system with R-12 and mineral oil. The compressor in an R-134a system will have to be replaced if the product has had a low side leak.

R-134a refrigerant molecules are smaller than R-12 molecules. This means that R-134a will pass more minor leaks and the rate of flow will be greater than for R-12. Therefore, it is now more important than ever to follow good brazing practices. Use a good grade of silver solder. 45% silver solder is recommended.

LEAK DETECTION

R-134a system leaks can be pinpointed by means of an electronic leak detector or by bubble solution.

Electronic leak detectors for R-134a service are currently available from several manufacturers. The least expensive models are non-selective detectors that will detect any type of emission or vapor present, regardless of its chemical composition. Some non-selective detectors designed for use with R-12 may have a much lower sensitivity when used with R-134a. However, newly designed detectors with good R-134a sensitivity are now available. Be sure to consult with the manufacturer before selecting or using a non-selective detector with R-134a.

Halogen-specific detectors use a specialized sensor that allows detection of compounds containing chlorine, fluorine, bromine, and iodine without being activated by other species. The major advantage of this type of

detector is a reduction in the number of “nuisance alarms”. Halogen-specific detectors are generally more expensive than non-selective detectors but feature higher sensitivity.

R-134a PROPERTIES

The properties of R-134a are very similar to those of R12. The principal data for the two refrigerants are shown in the chart below.

	REFRIGERANTS	
	R-12	R-134a
NAME	Dichlorodifluoromethane	1,1,1,2--Tetrafluoromethane
Formula	CCl_2F_2	$\text{CH}_2\text{F}-\text{CF}_3$
Molecular Weight (g/mol)	120.93	102.3
Ozone Depletion Potential (ODP)	1	0
Global Warming Potential (GWP)	3.1	0.3
Boiling Point °F	-21.6	-15.7
Vapor Pressure (77°F)	80 psig	82 psig
Flammability	None	None
Solubility of Water in Refrigerant (wt% @ 77°F)	0.009	0.11

HFC-134a, CFC-12 PRESSURE TEMPERATURE CHART

°F	°C	HFC-134a	CFC-12		°F	°C	HFC-134a	CFC-12
-60	-51.1	21.8*	19.0*		55	12.8	51.1	52.0
-55	-48.3	20.4*	17.3*		60	15.6	57.3	57.7
-50	-45.6	18.7*	15.4*		65	18.3	63.9	63.8
-45	-42.8	16.9*	13.3*		70	21.1	70.9	70.2
-40	-40.0	14.8*	11.0*		75	23.9	78.4	77.0
-35	-37.2	12.5*	8.4*		80	26.7	86.4	84.2
-30	-34.4	9.8*	5.5*		85	29.4	94.9	91.8
-25	-31.7	6.9*	2.3*		90	32.2	103.9	99.8
-20	-28.9	3.7*	0.6		95	35.0	113.5	108.3
-15	-26.1	0.0	2.4		100	37.8	123.6	117.2
-10	-23.3	1.9	4.5		105	40.6	134.3	126.6
-5	-20.6	4.1	6.7		110	43.3	145.6	136.4
0	-17.8	6.5	9.2		115	46.1	157.6	146.8
5	-15.0	9.1	11.8		120	48.9	170.3	157.7
10	-12.2	12.0	14.6		125	51.7	183.6	169.1
15	-9.4	15.0	17.7		130	54.4	197.6	181.0
20	-6.7	18.4	21.0		135	57.2	212.4	193.5
25	-3.9	22.1	24.6		140	60.0	227.9	206.6
30	-1.1	26.1	28.5		145	62.8	244.3	220.3
35	1.7	30.4	32.6		150	65.6	261.4	234.6
40	4.4	35.0	37.0		155	68.3	279.5	249.5
45	7.2	40.0	41.7		160	71.1	298.4	265.1
50	10.0	45.3	46.7		165	73.9	318.3	281.4

FIGURES WITH ASTERISKS (*) = IN. HG. VACUUM

FIGURES WITHOUT ASTERISKS = PSIG

R-134A HEALTH AND SAFETY INFORMATION

INHALATION TOXICITY

HFC-134a poses no acute or chronic hazard when it is handled in accordance with DuPont recommendations and when exposures are maintained at or below the DuPont Acceptable Exposure Limit (AEL) of 1,000 ppm (8 and 12 hour Time-Weighted Average or TWA).

An AEL is an airborne exposure limit established by DuPont scientists that specifies time-weighted average (TWA) airborne concentrations to which nearly all workers may be repeatedly exposed without adverse effects. The AEL for HFC-134a has the same value as the Threshold Limit Values (TLVs) established for CFC-12 and HCFC-22. TLVs are established by the American Conference of Governmental and Industrial Hygienists (ACGIH).

However, inhaling high concentrations of HFC-134a vapor may cause temporary central nervous system depression with narcosis, lethargy and anesthetic effects. Other effects that may occur include dizziness, a feeling of intoxication and a loss of coordination. Continued breathing of high concentrations of HFC-134a vapors may produce cardiac irregularities (cardiac sensitization), unconsciousness, and with gross overexposure, death. Intentional misuse or deliberate inhalation of HFC-134a may cause death without warning. This practice is **extremely dangerous**.

If you experience any of the initial symptoms, move to fresh air and seek medical attention.

CARDIAC SENSITIZATION

If vapors are inhaled at a concentration of 75,000 ppm, which is well above the AEL, the heart may become sensitized to adrenaline, leading to cardiac irregularities and, possibly, to cardiac arrest. The likelihood of these cardiac problems increases if you are under physical or emotional stress.

Medical attention must be given immediately if exposed to high concentrations of HFC-134a. **DO NOT** treat with adrenaline (epinephrine) or similar drugs. These drugs may increase the risk of cardiac arrhythmias and cardiac arrest. If the person is having difficulty breathing, administer oxygen. If breathing has stopped, give artificial respiration.

SPILLS OR LEAKS

If a large release of vapor occurs, such as from a large spill or leak, the vapors may concentrate near the floor or low spots and displace the oxygen available for breathing, causing suffocation.

Evacuate everyone until the area has been ventilated. Use blowers or fans to circulate the air at floor level. DO NOT reenter the affected area unless you are equipped with a self-contained breathing apparatus or unless an area monitor indicates that the concentration of HFC-134a vapors in the area is below the AEL.

Always use self-contained breathing apparatus or an air-line mask when entering tanks or other areas where vapors might exist. Use the buddy system and a lifeline. Refer to the Material Safety Data Sheet (MSDS) for HFC-134a for more information.

HFC-134a vapors have a slightly sweet odor that can be difficult to detect. Therefore, frequent leak checks and the installation of permanent area monitors may be necessary in enclosed spaces. Refer to ASHRAE Standards 15 and 34 for refrigeration machinery rooms.

To ensure safety when working with HFC-134a in enclosed areas:

1. Route relief and purge vent piping (if present) outdoors, away from air intakes.
2. Make certain area is well ventilated, using auxiliary ventilation, if necessary, to move vapors.
3. Make sure area is clear of vapors prior to beginning work.
4. Install air monitoring equipment to detect leaks.

SKIN AND EYE CONTACT

At room temperature, HFC-134a vapors have little or no effect on the skin or eyes. However, in liquid form, HFC-134a can freeze skin or eyes on contact, causing frostbite. Following contact, soak the exposed area in lukewarm water, not cold or hot. If medical treatment cannot begin immediately, apply a light coat of a nonmedicated ointment, such as petroleum jelly. If the exposed area is in a location where the presence of the ointment would be awkward, such as on the eye, apply a light bandage. In all cases of frostbite, seek medical attention as soon as possible.

Always wear protective clothing when there is a risk of exposure to liquid HFC-134a. Where splashing is possible, **always** wear eye protection and a face shield.

COMBUSTIBILITY OF HFC-134a

HFC-134a is nonflammable at ambient temperatures and atmospheric pressure. However, tests have shown HFC-134a to be combustible at pressures as low as 5.5 psig (139.3 kPa absolute) at 177°C (350°F) when mixed with air at concentrations generally greater than 60% volume air. At lower temperatures, higher pressures are required for combustibility. (HCFC-22 is also combustible at pressures above atmospheric in the presence of high air concentrations). Test results and calculations have shown:

- At ambient temperature, all concentrations of HFC-134a in air are nonflammable at pressures below 15 psig (205 kPa absolute).
- Combustible mixtures of air and HFC-134a will not form when liquid HFC-134a is pumped into closed vessel if initial air pressure in vessel is limited to one atmosphere absolute and final pressure is limited to 300 psig (2,170 kPa absolute). If initial air pressure is greater than one atmosphere, combustible mixtures may form as tank is filled.

Based on above information, the following operating practices are recommended:

Leak Testing

- Equipment should **NEVER** be leak tested with a pressurized mixture of HFC-134a and air. HFC-134a may be safely pressured with dry nitrogen.

Bulk Delivery and Storage

- Tanks should normally be evacuated at start of filling, and should never be filled while under positive air pressure.
- Tank pressure should never be allowed to exceed 300 psig (2,170 kPa) when filling with HFC-134a. Relief devices on either tanks or HFC-134a supply system usually prevent this.
- Tank pressures should be monitored routinely.
- Air lines should never be connected to storage tanks.

Filling and Charging Operations

- Before evacuating cylinders or refrigeration equipment, any remaining refrigerant should be removed by recovery system.
- Vacuum pump discharge lines should be free of restrictions that could increase discharge pressures above 15 psig (205 kPa) and result in formation of combustible mixtures.
- Cylinders or refrigeration equipment should normally be evacuated at start of filling, and should never be filled while under positive air pressure.
- Final pressures should not exceed 300 psig (2,170 kPa).
- Filled cylinders should periodically be analyzed for air (nonabsorbable gas or NAG).

Refrigerant Recovery Systems

Efficient recovery of refrigerant from equipment or containers requires evacuation at the end of the recovery cycle. Suction lines to a recovery compressor should be periodically checked for leaks to prevent compressing air into the recovery cylinder during evacuation. In addition, the recovery cylinder pressure should be monitored, and evacuation stopped in the event of a rapid pressure rise indicating the presence of noncondensable air. The recovery cylinder contents should then be analyzed for NAG, and the recovery system leak checked if air is present. DO NOT continue to evacuate a refrigeration system that has a major leak.

THERMAL DECOMPOSITION

HFC-134a vapors will decompose when exposed to high temperatures from flames or electric resistance heaters. Decomposition may produce toxic and irritating compounds, such as hydrogen fluoride. The pungent odors released will irritate the nose and throat and generally force people to evacuate the area. Therefore, it is important to prevent decomposition by avoiding exposure to high temperatures.

SECTION F - ICE MAKER

REAR MOUNTED ICE MAKER

The automatic ice maker is mounted in the freezer compartment. It is attached to a bracket extending up from the back of the auger motor cover.

The Ice Maker is designed to produce ice automatically. The length of time between harvest cycles will vary, depending on load conditions, door openings, ambient temperature and freezer temperature and water temperature. These factors must be taken into consideration when checking the ice production rate.

With a temperature of -2°F to $+5^{\circ}\text{F}$ in the freezer, the rate of harvest will be 40 to 96 cubes per 24 hour period.

The ice maker is wired across the line and will harvest ice in the refrigeration or defrost cycles.

The water valve and solenoid assembly are both mounted in the compressor compartment.

A tube extends from the water valve up the rear wall of the refrigerator to a water inlet spout that directs the water into the fill trough. The water fill spout will twist lock into a housing in the back of the refrigerator and direct water flow into the ice maker from the side of the mold.

Front Cover (Figure F4)

A decorative front cover, made of molded plastic, encloses the operating mechanism of the ice maker, protecting it from moisture. It is essential that the cover be in place on an operating ice maker to protect against possible contact with the mechanism by the user. (See Figure F1)

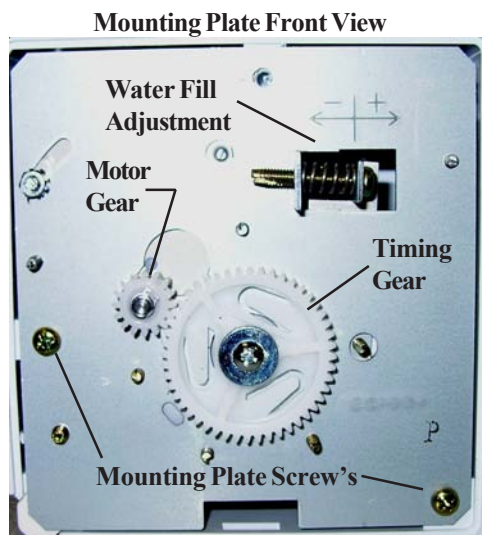

Figure F1

ICE MAKER COMPONENTS

Ice Mold (Figure F5)

The ice mold is die-cast aluminum with the ice maker thermostat bonded to its front surface. The mold has a semi-circular interior partitioned into equal size compartments. Water enters at the side of the mold, through a fill trough. A film of silicon grease on the top edge of the mold prevents siphoning of water by capillary action.

Mold Heater (Figure F6)

A mold heater, rated at 112 watts at 115volts, $\pm 10\%$ it is covered with an aluminum sheath and embedded in the grooved section on the underside of the Ice Mold. When the mold heater is energized, the ice contact surface within the mold is heated enough to allow harvest of the ice pieces.

The mold heater is wired in series with the Ice Maker thermostat, which acts as a safety device.

The heater is staked in place, and is replaced as part of the ice maker Mold.

A thermal mastic sealer is placed between the heater and the mold to ensure good thermal contact.

Ice Stripper (Figure F5)

An Ice Stripper is attached to the mold to prevent ice pieces from falling back into the mold. It also serves as a decorative side cover.

Ice Ejector (Figure F5)

The Ejector blades are molded from delrin, and extend from a central shaft, which turns in nylon bearings at the front and rear. Each blade sweeps an ice section out of the mold. The drive end of the Ice ejector is "D" shaped. Food Grade Silicone grease is used to lubricate the bearing surfaces.

Water Valve Assembly

The water valves are solenoid operated and when energized, releases water from the water tank in the food compartment into the Ice Mold. The amount of water released is directly proportional to the length of time the water valve Switch is energized. A flow washer, inside the water valve, maintains a constant rate of water flow over a supply line with pressure ranging from 20 to 100 psig. It will not compensate for pressures below 20 psig, or greater than 100 psig. A No. 80-mesh screen, placed ahead of the flow washer, filters out foreign materials.

The solenoid coil draws 10 to 20 watts of power. The coil is wired in series with the mold heater, across the supply voltage.

Thermostat (Figure F6)

The thermostat is a single-pole, single throw (SPST), bimetallic, disk-type, thermal switch. It automatically starts the harvest cycle when the ice is frozen. The thermostat closes at a temperature of $9^{\circ}\text{F} \pm 2^{\circ}$. Wired in series with the mold heater, the thermostat acts as a safety device against overheating in the event of mechanical failure. A thermal mastic bond is provided where the thermostat is mounted against the mold. A gasket prevents water from leaking into the support housing.

Sensing Arm & Linkage (Figure F5 & 6)

The sensing arm is cam-driven and operates a switch that controls the quantity of ice produced. In the harvest Cycle, the arm is raised and lowered during each of the two revolutions of the timing cam. If the sensing arm comes to rest on top of ice in the storage compartment during either revolution, the switch will remain open and stop the ice maker at the end of that revolution. When sufficient ice is removed from the storage container, the sensing arm lowers and ice production resumes. To manually stop the ice maker turn the switch located on the housing at the left end of the icemaker to off. Operation is resumed when the switch is turned back to on.

Timing Switches (See Figure F2)

The three timing switches used are single-pole, double throw (SPDT). They are identical except for function, and can be used interchangeably.

1. **Hold Switch** - assures completion of a revolution once the ice maker operation has started.
2. **Water Fill Switch** - opens the water valve during the fill cycle. It is the only adjustable component in the ice maker.
3. **Shut-Off Switch** - stops ice maker operation when the storage container is full of ice. The switch is opened after the sensing arm is raised to its most upright position. The switch is mounted to the top right wall of the ice maker support. (Not shown in Figure F6)

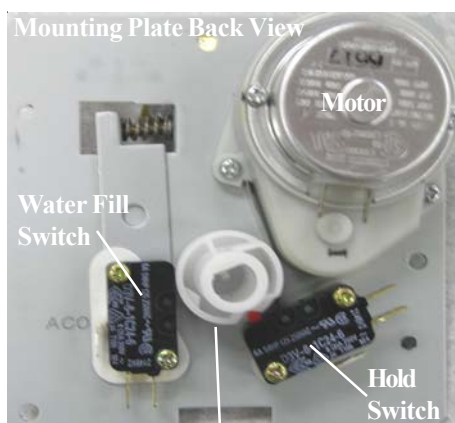

Timing Cam
Figure F2

Thermal Cut-Out (TCO)

The thermal cut-out is a one-time limit fuse used as a safety device. It is located under the mounting plate, in the head of the ice maker, between the thermostat and wire connector.

If the thermal cut-out opens, the cause of failure must be determined and corrected prior to replacing the TCO. Normal causes of the TCO failing are a bad thermostat or a shorted coil on the water valve.

Timing Cam & Coupler

Three separate cams are combined in one molded Delrin part:

1. Inner cam operates shut-off switch lever arm.
2. Center cam operates hold switch.
3. Outer cam operates water fill switch.

One cam end is attached to a large timing gear. The other cam end is coupled to the ejector.

Timing Gear (Figure F1)

This large molded plastic gear is driven by the motor and, in turn, rotates the cam and ejector. A "D" shaped hole in the gear fits over the timing cam hub. Spacer tabs on the backside of the gear prevent the gear from binding on the mounting plate.

Motor (Figure F2)

A low wattage, stall-type motor drives the timing gear. This gear turns the timing cam and ejector blades approximately one revolution every three minute (1/3 RPM).

On/Off Switch (Figure F5 & 6)

A single-pole, single-throw switch is mounted on the right side of the housing at the front of the ice maker. This switch is used to turn the ice maker off. Unlike the switch on the bail arm the on/off switch will stop the ice maker as soon as it is pushed, and it will not allow the ice maker to complete the revolution.

Wiring

A four-prong plug connects the ice maker wiring to the cabinet wiring harness. (See Figure F3.) The ice maker assembly is wired across the line and will harvest in either the refrigeration or defrost cycles. A wiring diagram is located inside the front cover of the ice maker.

Ice Maker Connector Plug

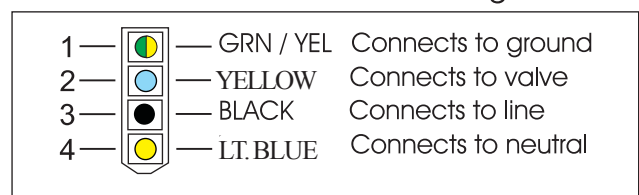

Figure F3

INSTALLING WATER SUPPLY LINE TO ICE MAKER

Supply line installation must comply with all applicable plumbing codes. Refer to the **Ice Maker Installation Instructions** in appendix A.

The ¼" tubing, and any other plumbing materials required, should be obtained locally.

The ice maker should be connected to a frequently used cold water line to ensure a fresh water supply.

NOTE: A vertical cold water line should be selected for the water supply. If a vertical line is not available, a horizontal line may be used, providing the connection is on the side or top of the pipe, but **not on the bottom**. Scale and foreign material in the pipe could cause stoppage of water flow if the connection is on the bottom.

Be sure to leak test all connections after the water supply has been turned on.

TEST CYCLING ICE MAKER (See *Ice Maker Testing Procedures* on pages F7 to F16).

It may be necessary, on occasion, to test-cycle an ice maker to check its operation. This can be done on the repair bench or while mounted in the refrigerator.

If the ice maker is in an operating refrigerator, take precautions against the formation of condensate by allowing the cold, metal components to warm up before removing the front cover. This can be expedited by cycling the assembly with the cover in place and the water supply valve closed.

To manually cycle the ice maker, push the on off switch to the on position then push in harder against the spring loaded second set of contacts in the switch and hold in until the hold switch circuit to the motor is completed. When the motor starts, all components except the ice maker thermostat should perform normally. Once the ice maker completes its cycle, if additional testing is necessary you can push in on the switch again to start the icemaker into another cycle.

WATER VALVE SWITCH – WATER FILL VOLUME

The amount of water fill is directly proportional to the length of time terminals "C-NC" of the water fill switch are closed. Closing occurs when the switch plunger drops into a cavity formed in the cam.

Different water valves have different flow rates. For this reason, anytime a water valve is replaced, the water fill must be checked and the fill switch must be adjusted if needed.

The correct water fill volume is 80 to 100 cc. To measure the fill volume, test-cycle the Ice Maker and collect the water. Measure in a container calibrated in cubic centimeters (CC) the fill time is 5.0 seconds.

The fill volume is adjusted by increasing or decreasing the length of time the water fill switch remains closed.

To adjust the water fill switch, first determine how much water is needed. The adjusting screw is calibrated so that one complete revolution changes the water fill about 18 cubic centimeters. Turning the screw clockwise decreases the fill, while turning counterclockwise increases the fill.

EXAMPLE: An ice maker is test-cycled and the water fill sample is 93 cubic centimeters. Subtracting 80 cc from 93, the adjustment needed is 13 cc. Since one turn of the adjusting screw changes the fill 18 cc, ¾ of a turn clockwise would reduce the fill about 13 cc, the desired amount. (This example is for manual models only.)

PARTS REPLACEMENT

Disconnect electrical supply to refrigerator.

To Replace Front Cover (Figure F4)

1. Remove ice maker from freezer.
2. Ensure that ice maker is at room temperature before removing Cover.
3. Remove screw at the top of the cover and tip it out until the tab at the bottom comes out of the housing.
5. Install in reverse order.

To Replace Fill Trough (Figure F6)

1. Remove ice maker form Freezer.
2. Push trough retaining tab back against the mold.
3. Pull the trough up until it is clear of the mold.
4. Replace in reverse order.



Figure F 4

To Replace Ice Stripper (Figure F5)

1. Remove ice maker from freezer.
2. Pull out on the stripper about 1 inch back from the front the ice maker till the retaining tab is away from the tab on the ice mold.
3. Pull back on ice stripper to disengage it from front of mold support housing.
4. Replace in reverse order.

To Replace Ejector Blades (Figure F5)

1. Remove ice maker form freezer.
2. Remove front cover.
3. Remove two screws holding mounting plate in place.
4. Carefully remove mounting plate, disengaging end of ice maker control arm and ejector blades from motor coupling, noting relative position of ice maker control arm spring.
5. Remove fill trough and bearing.
6. Turn blades to 12 O'clock position.
7. Slide ejector blades back and up to remove.
8. Replace in reverse order.
9. Lubricate bearing ends of ejector with silicone grease.

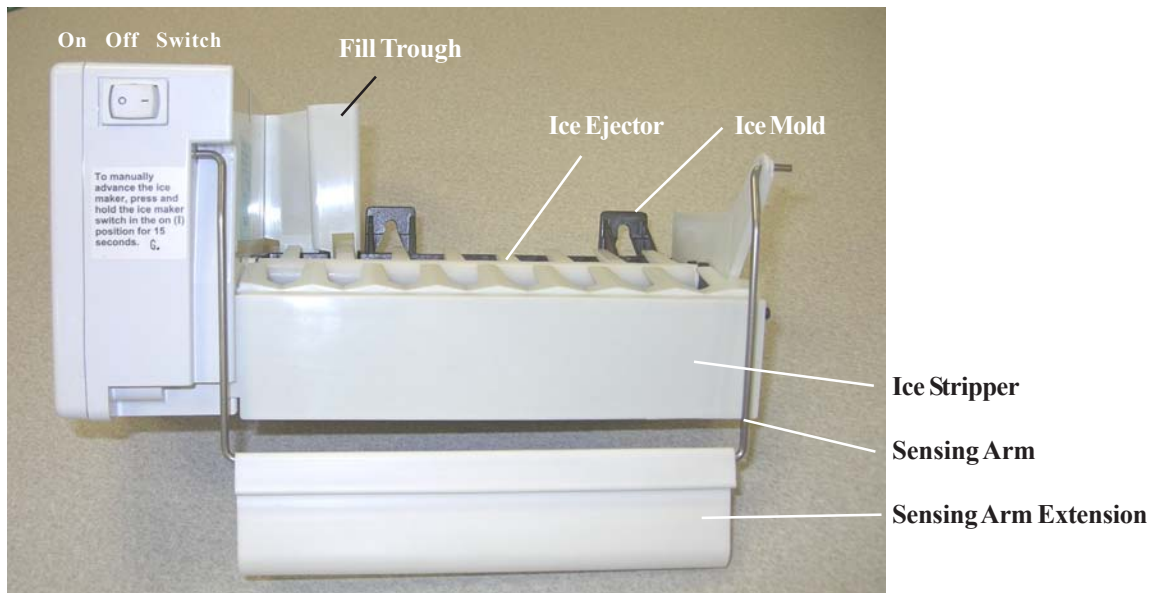

Figure F 5

To Replace Motor and Switch Mounting Plate

1. Remove ice maker from freezer.
2. Remove front Cover.
3. Remove two screws that attach mounting plate to support housing.
4. Carefully remove mounting plate, disengaging end of sweep arm and noting relative position of sweep arm spring.
5. Transfer motor, switches, cam, gear, and water fill adjusting spring and arm to replacement mounting plate.
6. Attach new mounting plate to support housing with three screws.

NOTE: Ensure that the wiring harness is properly positioned and the sweep arm is in place.

7. Check water fill cycle and adjust as required.
8. Replace front cover.

To Replace Motor (Figure F2)

1. Remove ice maker from freezer.
2. Remove front cover.
3. Remove two screws that attach mounting plate to support housing.
4. Disconnect two motor leads.
5. Remove two motor mounting screws.
6. Replace motor in reverse order.

To Replace Water Fill Switch (Figure F2)

1. Remove ice maker from freezer.
2. Remove front Cover.
3. Remove two screws that attach mounting plate to support housing.
4. Disconnect two water fill switch wire leads.
5. Remove two switch mounting screws.
6. Remove switch.

7. Replace switch in reverse order, ensuring that switch insulator is in place.
8. Check water fill cycle and adjust as required.

To Replace Hold Switch (Figure F2)

1. Remove ice maker form freezer.
2. Remove front cover.
3. Remove two screws that attach mounting plate to support housing.
4. Disconnect six hold switch wire leads.
5. Remove two hold switch mounting screws.
6. Remove hold switch.
7. Replace in reverse order.

To Replace Ice Maker Control Arm Shut-OFF Switch

1. Remove ice maker form freezer.
2. Remove front Cover.
3. Remove two screws that attach mounting plate to support housing.
4. Disconnect three ice maker control arm shut-off switch wire leads.
5. Raise ice maker control arm lever.
6. Remove two ice maker control arm shut-off switch mounting screws.
7. Remove switch.
8. Replace switch in reverse order.

To Replace Ice Maker Thermostat (Figure F6)

1. Remove Ice Maker form Freezer.
2. Remove front Cover.
3. Remove two screws that attach mounting plate to support housing and remove plate.
4. Disconnect two thermostat wire leads and remove thermostat.
5. Remove two screws that attach mold to support Housing separate housing and ice mold.
6. Remove thermostat.
7. Apply thermal mastic sealer to sensing surface of replacement thermostat to ensure a positive bond to mold.
8. Replace thermostat in reverse order.

To Replace Thermal Cut-Out (TCO)

1. Remove Ice maker form freezer.
2. Remove front Cover.
3. Remove two screws that attach mounting plate to support housing.
4. Pull cable assembly free from support housing. It will slide out easily.
5. Loosen screw securing clamp to TCO. TCO should come free after tension from clamp is released.
6. Disconnect TCO from two wire nuts. One end is connect to the cable assembly and the other end is connected to the motor and mold heater.

7. Replace with new TCO.
8. Reassemble in reverse order.

To Replace Ice Mold and Heater

1. Remove ice maker form freezer.
2. Remove front cover.
3. Remove ice stripper. (Refer to Section "To Replace Ice Stripper" on page F 4)
4. Remove two screws that attach mounting plate to support housing.
5. Remove two screws that attach mold to support Housing.
6. Disconnect the wire nut on the right holding three black leads together and separate them.

NOTE: One black lead is connected to the mold heater. Another is connected to the thermostat and the third lead goes to the hold switch.

7. Disconnect the wire nut on the left holding three black leads together and separate them.
8. Separate mold from support housing.
9. Remove hex head screw holding ice maker leveling bracket to mold.
10. Apply layer of thermal mastic sealer to the new ice mold in the location the thermostat mounts.
11. Replace parts in reverse order. Ensure that thermostat gasket is in place. Bond thermostat to mold with thermal mastic sealer.

NOTE: For best operation, the freezer temperature should be between -2°F to +4°F.

FAULT DIAGNOSIS

Complaint - Ice Maker Fails to Start

1. Check to see if ice maker control arm is locked in raised position.
2. Check terminals from cabinet wiring to ice maker for open circuit in wiring or components.
3. Check operation of the ice maker with test service cord.
4. Check mold temperature at a mounting screw. If temperature is above 15°F, freezer air temperature is not cold enough to switch ice maker thermostat to closed position. If mold is below 9°F, manually start ice maker by rotating timer gear. If motor fails to start, check motor for continuity. If motor starts, thermostat, shut-off switch, or hold switch is inoperative.
5. Check hold switch first. with ejector blades in the starting position, check terminals "C" and "NC" for continuity. Replace switch if continuity readings are open. check shut-off switch linkage. Then check terminals "NO" and "C" for continuity with ice maker control arm in lowest position. Replace switch if continuity readings are open. If hold switch and shut-off switch are operative, then replace thermostat.

Complaint-Ice Maker Fails to Complete Cycle.

1. With Ejector blades at 10 o'clock position, hold switch plunger depressed, check terminals "C" and "NO" for continuity. Replace switch if continuity readings are open.
2. With Ejector blades at 12 o'clock position, check shut-off switch terminals "C" and "NC" for continuity. Replace thermostat if continuity readings are open.

3. With ejector blades at 4 o'clock position, check mold heater and ice maker thermostat for continuity. Replace heater if continuity readings are open. If heater shows continuity, replace thermostat.
4. Check Motor operation with a test cord. Replace motor if it fails to start.

Complaint-Ice Maker Fail to Stop at End of Cycle

With the ejector blades in the starting position, check the hold switch terminals "C" and "NO" for continuity. Replace the switch if the continuity readings are indicating a closed circuit.

Complaint-Ice Maker Continues to Eject When Container is Full.

1. Check for loose linkage to the Ice maker control arm shut-off switch. Switch should open when arm is in raised position. Adjust, if required.
2. Check shut-off switch terminals "C" and "NO" for continuity with Ice maker control arm raised. Replace switch if continuity readings are indicating a closed circuit.

Complaint-Ice Maker Produces Undersized Ice Pieces

1. Ensure that ice maker mold is level.
2. Check for partial restriction in supply line or water valve strainer.
3. Ensure that the water pressure to water valve is sufficient. (20 psi min., 120 psi max.)
4. Ensure that the water valve switch is adjusted for proper water fill, 78 to 83 cc's.
5. Check thermal bond between thermostat and mold. If necessary, rebond with thermal mastic sealer.

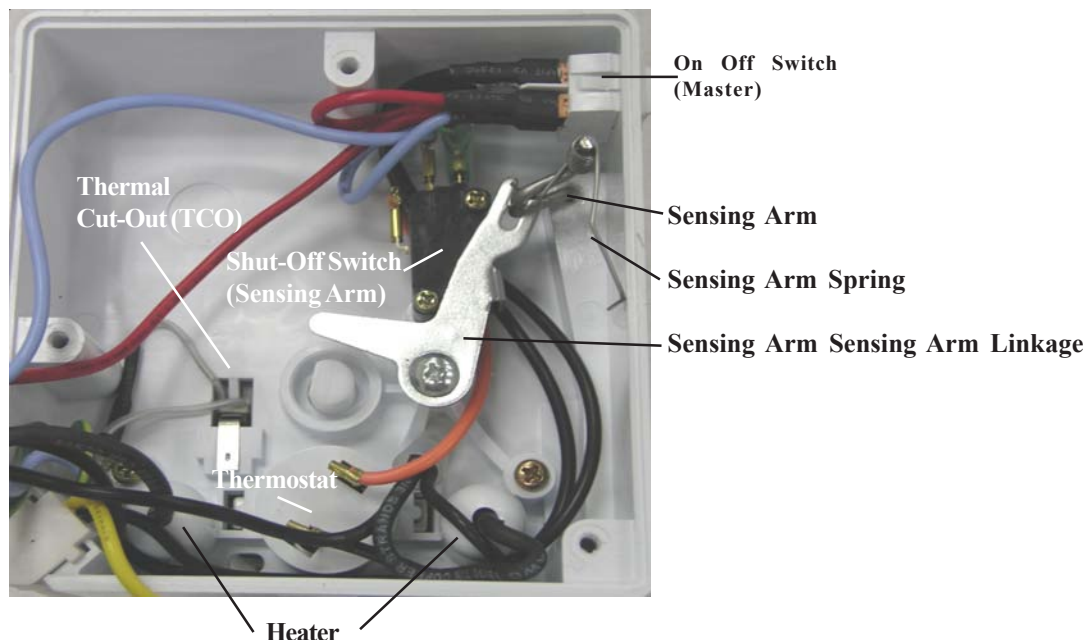

Figure F 6

ICE MAKER TESTING PROCEDURES

Operating Cycle

Operation of the ice Maker, water refilling, and controlled ice storage, require proper functioning and timing of all components.

Consider the following:

- Has refrigerator been properly installed and connected to sources of electrical power and water?
- Has freezer compartment evaporator pulled down to temperature?
- Is the ice maker turned on?
- Have several ice making cycles been completed to remove all the air form the water lines?
- Do the ejector blades make two revolutions per cycle? Is ice stored on blades after harvest?
- Is the water solenoid wired in series with the mold heater?

Operating Cycle Illustrations - Manual Cycle

To manually cycle ice maker:

1. Turn the On Off switch to ON
2. Press in on switch holding the spring loaded contact set closed, this will allow the motor to start.
3. Hold in on the switch for 10 seconds to allow hold switch contacts to close allowing the ice maker to continue through a cycle.

Operating Cycle Illustrations - Electrical

The following wiring diagrams illustrate the electrical operation of a rear mount ice maker.

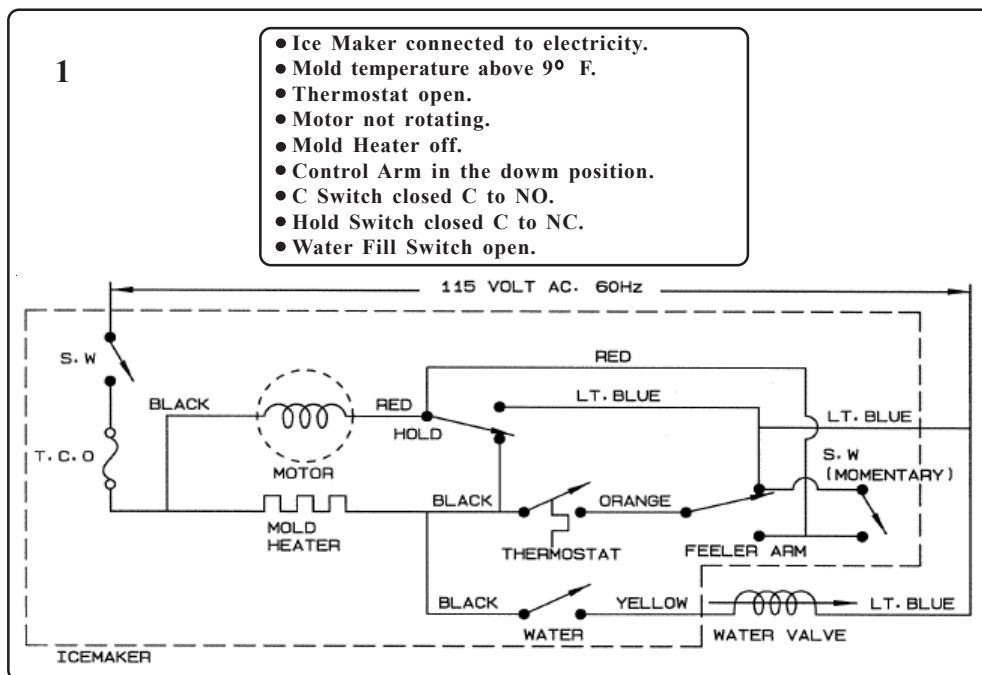

2

- Ice Maker connected to electricity.
- Mold temperature above 9° F.
- Thermostat closes.
- Motor starting.
- Mold starting to heat.
- Control Arm in the down position.
- Feeler Arm Switch closed C to NO.
- Hold Switch closed C to NC.
- Water Fill Switch open.

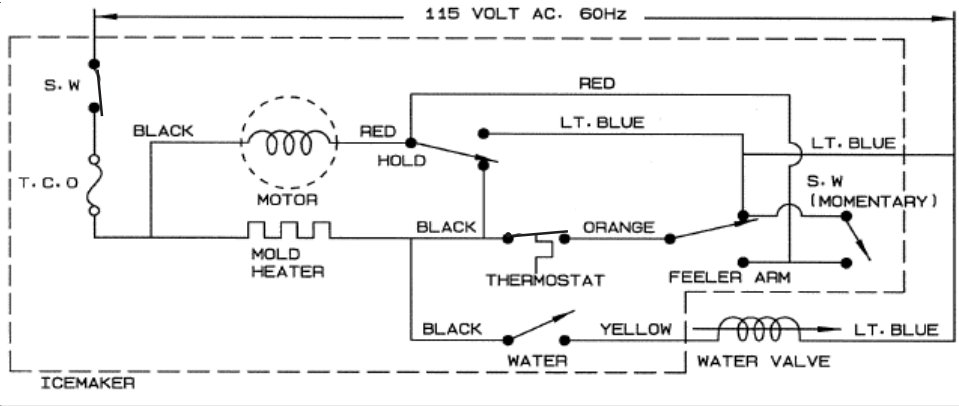

3

- Ice Maker connected to electricity.
- Mold temperature above 9° F.
- Thermostat closed.
- Motor starting to rotate.
- Mold starting to heat.
- Control Arm in the down position.
- Feeler Arm Switch closed C to NO.
- Hold Switch closed C to NO.
- Water Fill Switch open.

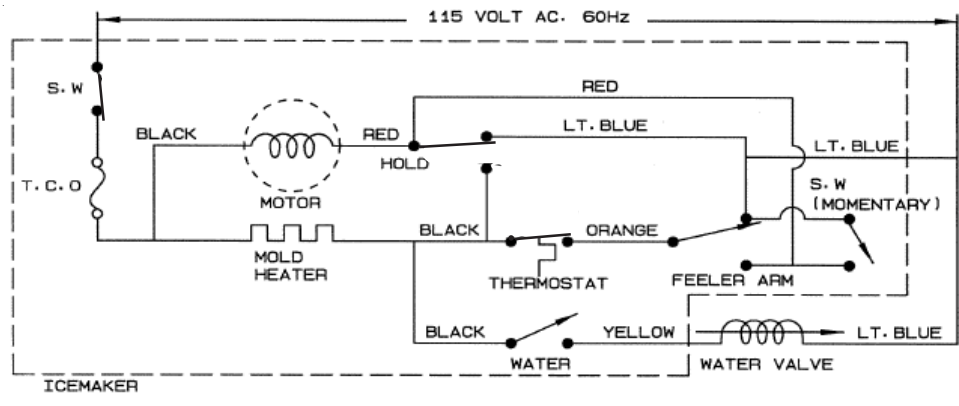

4

- Ice Maker connected to electricity.
- Mold temperature above 90° F.
- Thermostat closed.
- Motor rotating.
- Mold Heating.
- Control Arm swinging up.
- Feeler Arm Switch closed C to NC.
- Hold Switch closed C to NO.
- Water Fill Switch open.

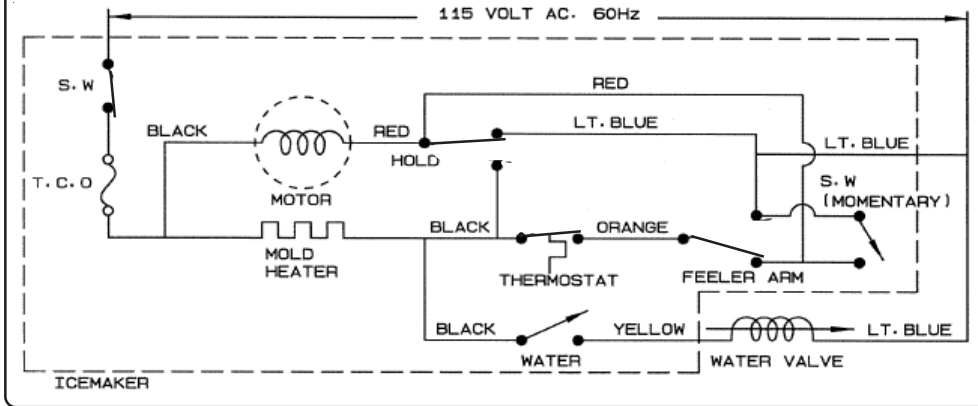

5

- Ice Maker connected to electricity.
- Mold temperature above 90° F.
- Thermostat closed.
- Motor stalls as ejector hits ice in mold.
- Mold Heating.
- Control Arm swinging down.
- Feeler Arm Switch closed C to NC.
- Hold Switch closed C to NO.
- Water Fill Switch open.

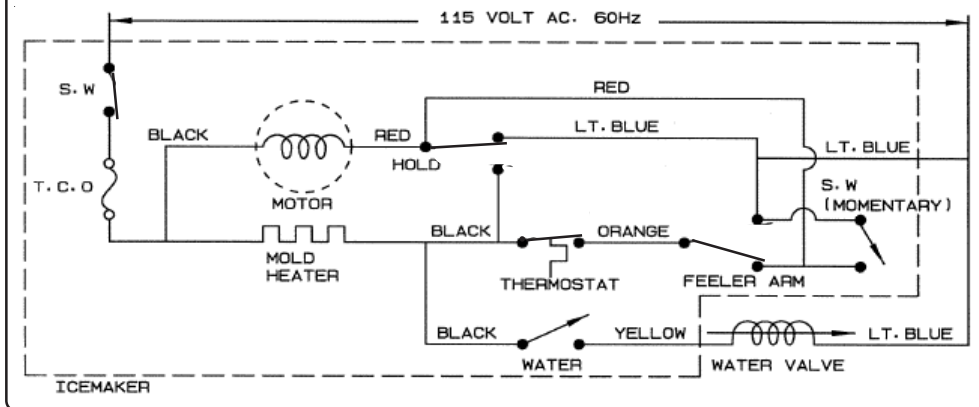

6

- Ice Maker connected to electricity.
- Mold temperature above 90° F.
- Thermostat closed.
- Motor starts to rotate as ice brakes loose.
- Mold Heating.
- Control Arm is down.
- Feeler Arm Switch closed C to NO.
- Hold Switch closed C to NO.
- Water Fill Switch closed but shorted out by thermostat.

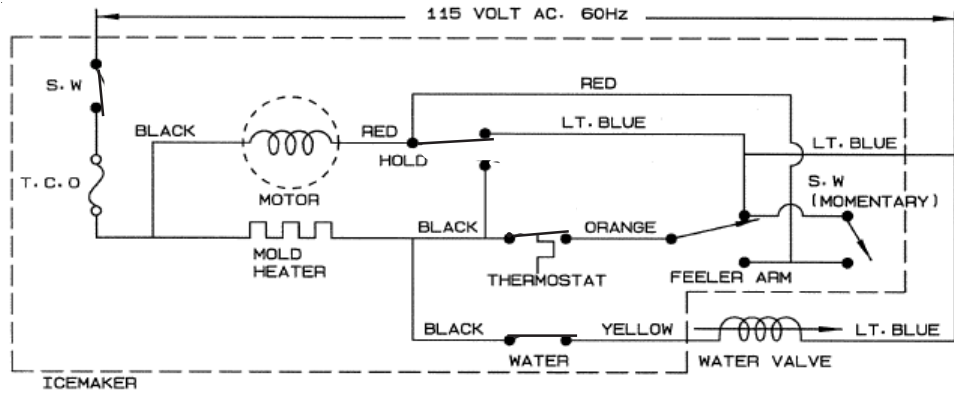

7

- Ice Maker connected to electricity.
- Mold temperature above 90° F.
- Thermostat closed.
- Motor is rotating.
- Mold Heating.
- Control Arm is down.
- Feeler Arm Switch closed C to NO.
- Hold Switch closed C to NC.
- Water Fill Switch open.

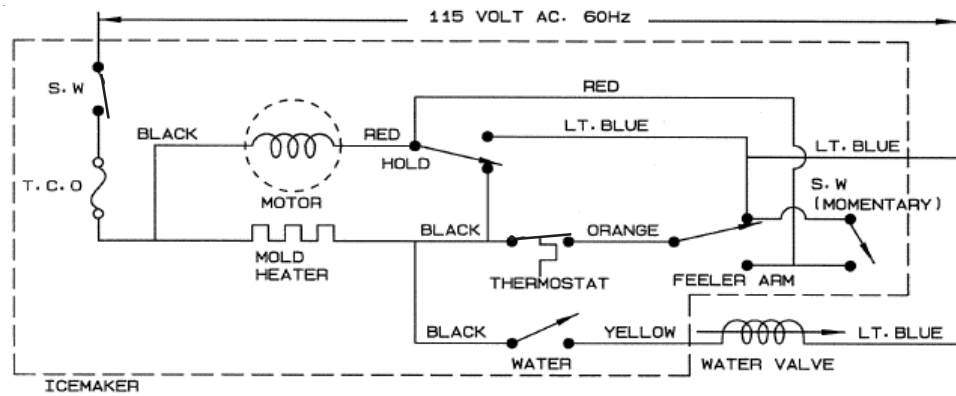

8

- Ice Maker connected to electricity.
- Mold temperature above 90° F.
- Thermostat closed.
- Motor is rotating.
- Mold Heating.
- Control Arm swinging up.
- Feeler Arm Switch closed C to NO.
- Hold Switch closed C to NO.
- Water Fill Switch open.

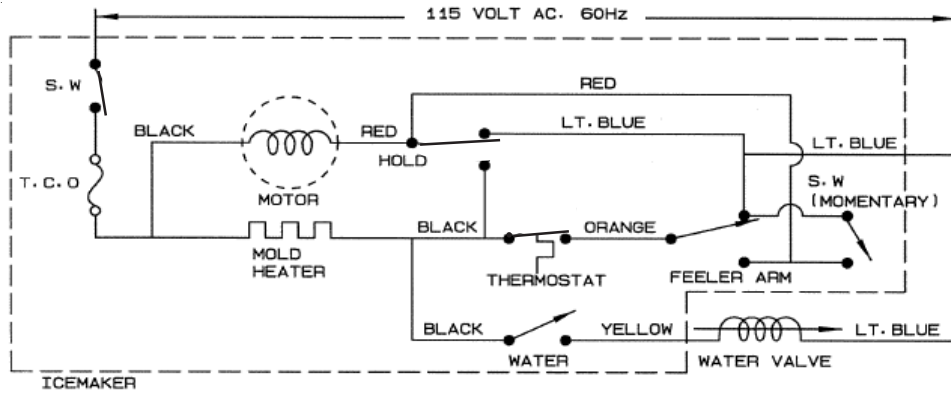

9

- Ice Maker connected to electricity.
- Mold temperature above 90° F.
- Thermostat closed.
- Motor is rotating.
- Mold Heating.
- Control Arm swinging up.
- Feeler Arm Switch closed C to NC.
- Hold Switch closed C to NO.
- Water Fill Switch open.

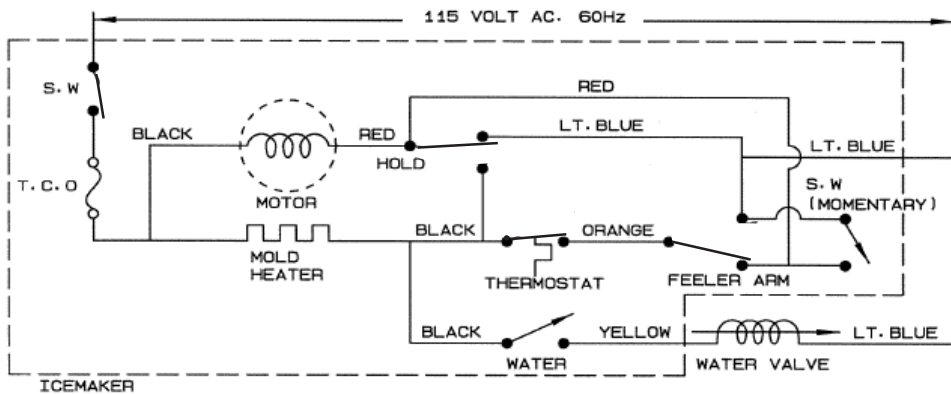

10

- Ice Maker connected to electricity.
- Mold temperature above 40° F.
- Thermostat opens.
- Motor is rotating.
- Mold Heater off.
- Control Arm swinging up.
- Feeler Arm Switch closed C to NC.
- Hold Switch closed C to NO.
- Water Fill Switch open.

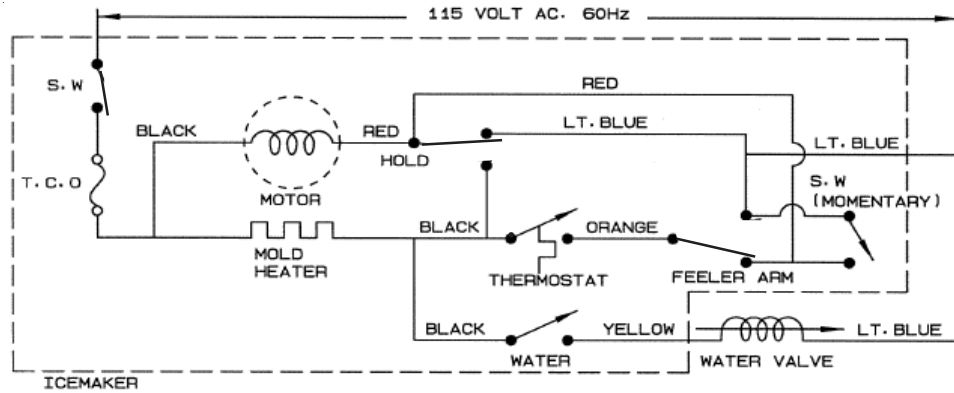

11

- Ice Maker connected to electricity.
- Mold temperature above 9 °F.
- Thermostat open.
- Motor is rotating.
- Mold Heater off.
- Control Arm swinging down.
- Feeler Arm Switch closed C to NO.
- Hold Switch closed C to NO.
- Water Fill Switch open.

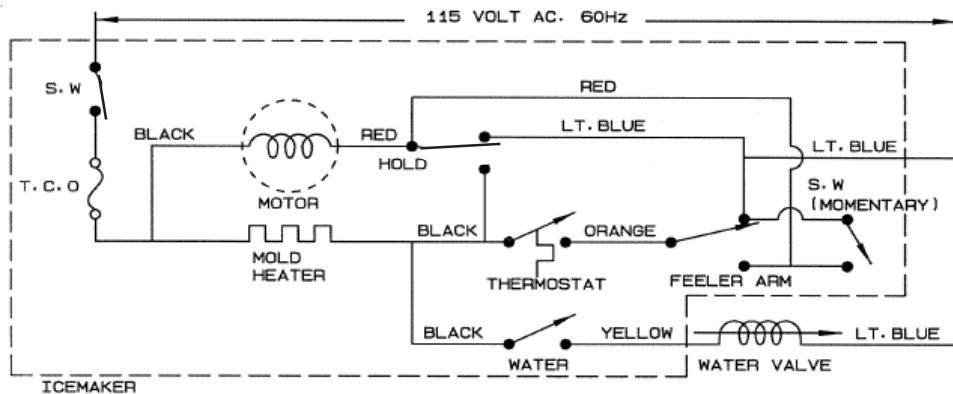

12

- Ice Maker connected to electricity.
- Mold temperature above 9 °F.
- Thermostat open.
- Motor is rotating.
- Mold Heater is in series with water valve.
- Control Arm swinging down.
- Feeler Arm Switch closed C to NO.
- Hold Switch closed C to NO.
- Water Fill Switch closed.

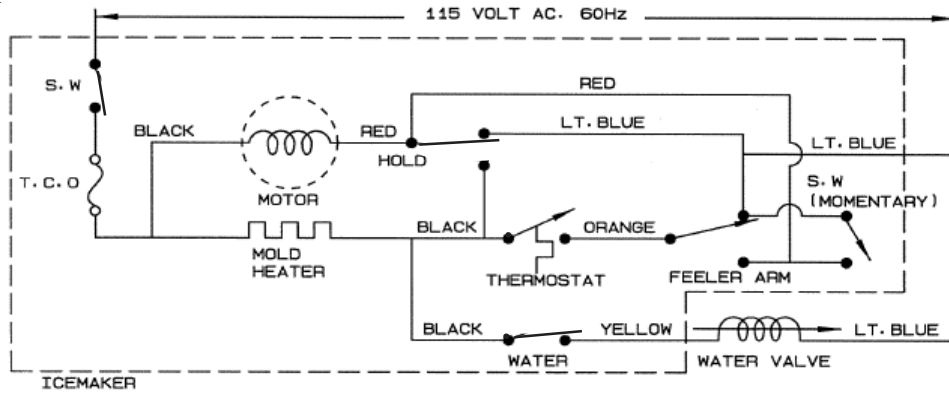

13

- Ice Maker connected to electricity.
- Mold temperature above 9 °F.
- Thermostat open.
- Motor is rotating.
- Mold Heater off.
- Control Arm swinging down.
- Feeler Arm Switch closed C to NO.
- Hold Switch closed C to NO.
- Water Fill Switch open.

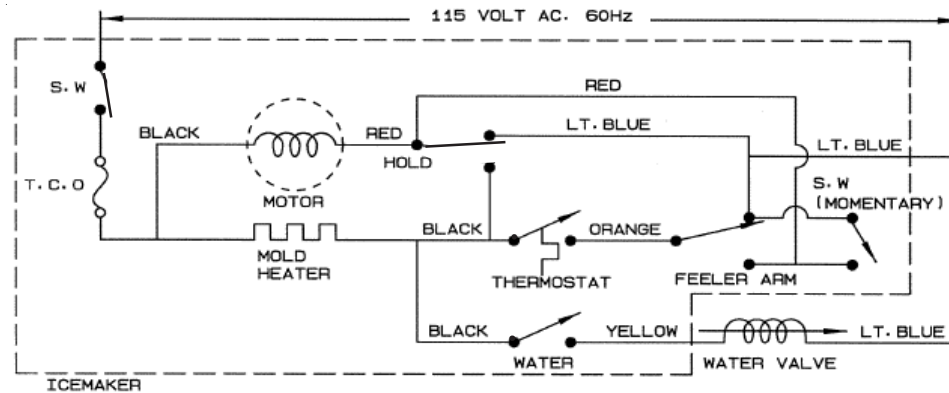

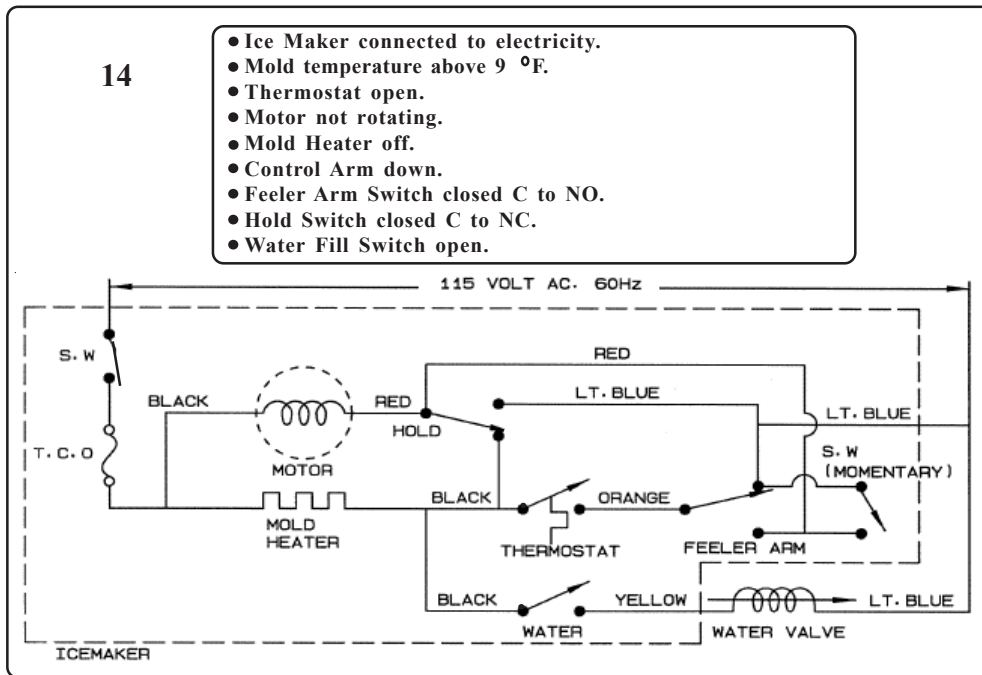

Operating Cycle Illustrations - Mechanical

The following Figures illustrate the mechanical operation of an Ice Maker.

Step 1

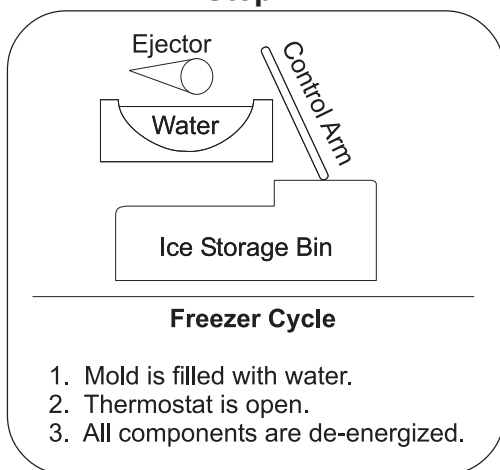

Step 2

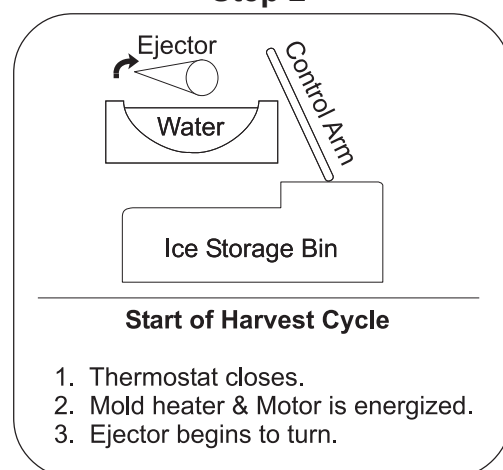

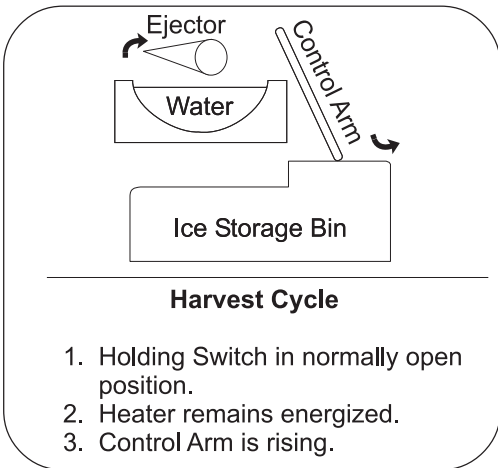

Step 3

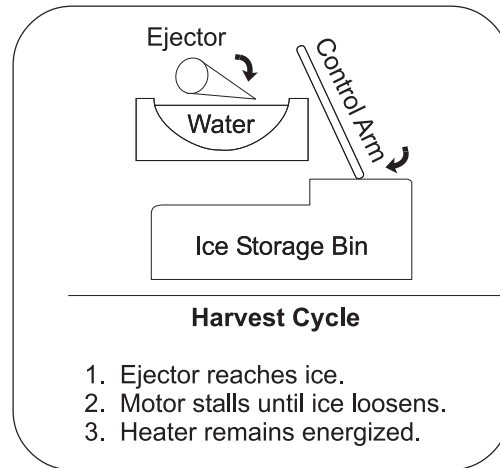

Step 4

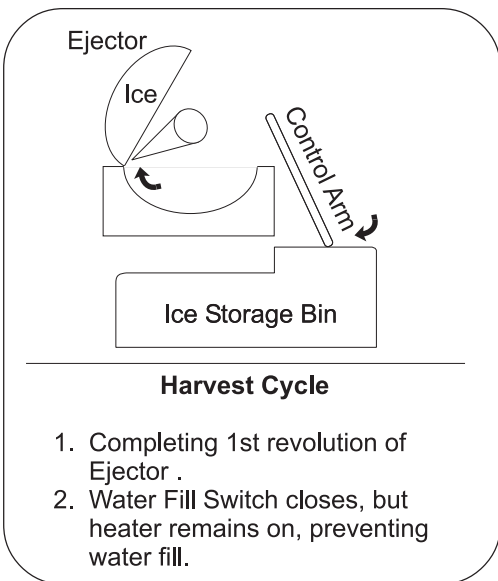

Step 5

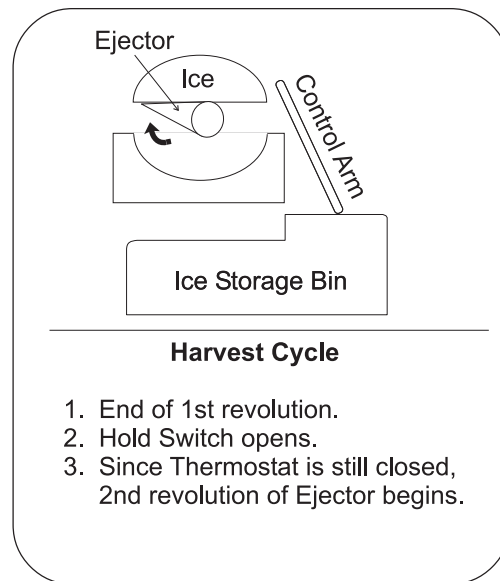

Step 6

Step 7

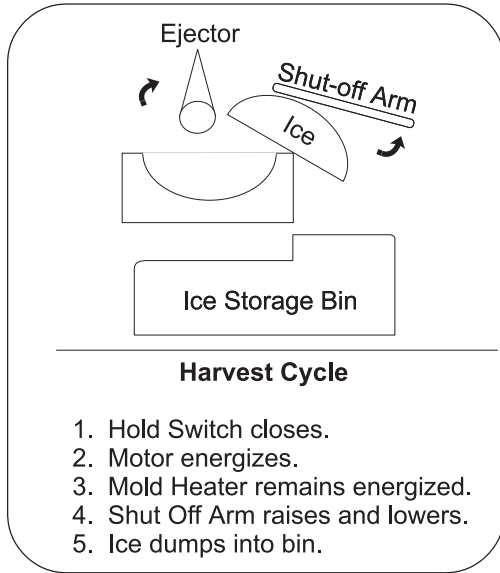

Step 8

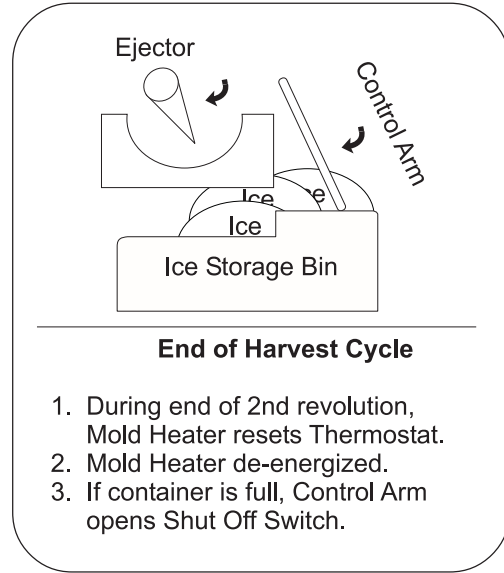

Step 9

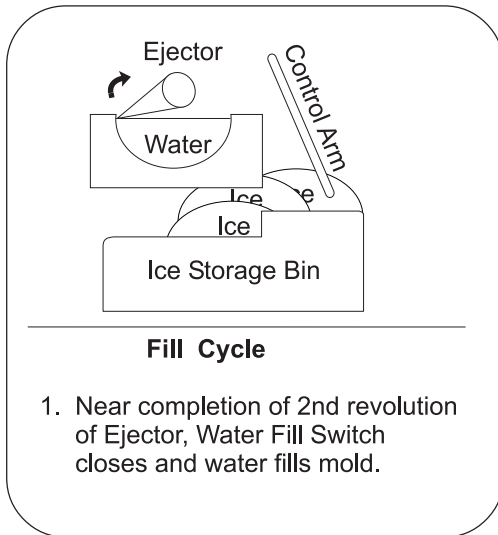

Step 10

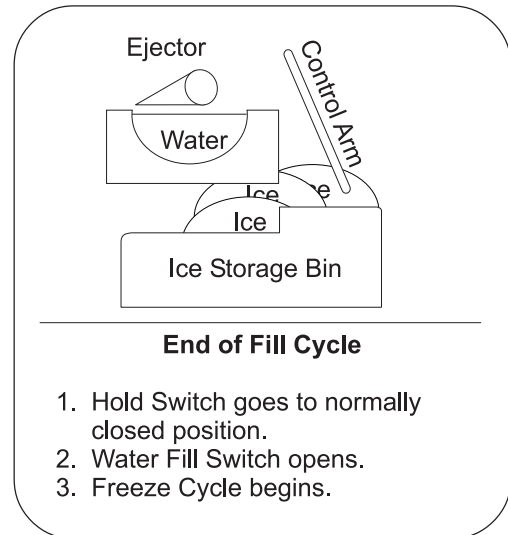

Ice Maker Wiring Diagrams (Enlarged view)

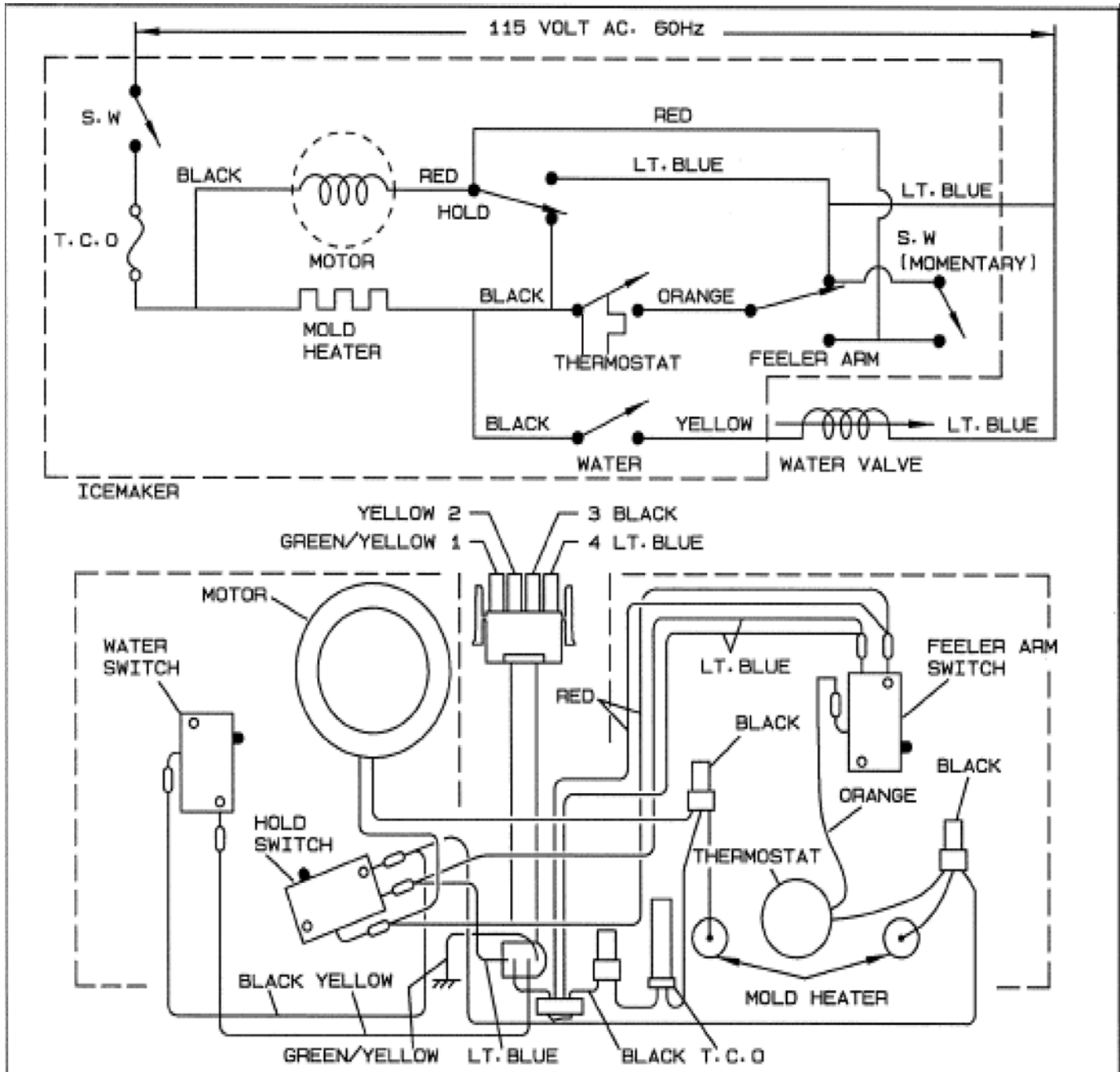

SECTION G - ICE & WATER DISPENSER

ICE DISPENSER CONTAINER & RAIL ASSEMBLY

The Ice Dispenser Container slides into the Rail Assembly mounted directly below the Ice Maker. Ice is ejected from the container by an Ice Auger connected to the Solenoid Assembly, and dispensed at the bottom front of the container where it enters through a Gate on the Crusher Housing. The Gate is opened and closed by a Control Rod that fits in the Actuator of the Solenoid Assembly. The ice is then directed into an ice chute mounted on the interior of the freezer door. The Ice Container must be properly placed on the rail assembly to assure proper dispensing. The container should be slid on top of the rails on the Rail Assembly up against the Motor Cover, with the Rotation Stop and Ice Auger protruding through the holes in the back of the Ice Container.

Dispenser Auger Motor & Solenoid Assembly (Solenoid Assembly not on all models)

The dispenser Auger Motor, Solenoid Assembly, Light Socket and Bulb (40 Watt appliance bulb), and wiring disconnects are mounted on the back on the Rail Assembly Motor Cover. The motor and solenoid mounting screws are located on the front of the Motor Cover.

To Remove Auger Motor:

1. Disconnect refrigerator from electrical supply.
2. Slide Ice Container forward and off of Rail Assembly. Remove 2 screws holding Rail Assembly to Evaporator Cover.
3. Lift up on Rail Assembly and pull forward, freeing it from mounting brackets.
4. Disconnect Molex connector located at back of Rail Assembly and pull Rail Assembly free.
5. Remove screw securing green ground wire to motor housing on back of Motor Cover. (See Figure G1)
6. Disconnect two (2) leads hooked to Auger Motor windings (Leads are purple and white - See Figure G1).
7. Rotate Drive Bar and Nut (located on front of Motor Cover) in counterclockwise position until it comes free of Auger Motor shaft. (See Figure G2)
8. Remove four (4) motor mounting screws and pull Auger Motor free from Motor Cover.
9. Replace assembly in reverse order.

To Test Auger Motor:

1. Read ohmic value of motor windings using Multimeter on resistance scale. (Put test leads on terminals where purple and white wires were disconnected from Step 6 of procedure "To Remove Auger Motor").

2. Resistance reading should be low ohms. If you get anything else, replace motor.

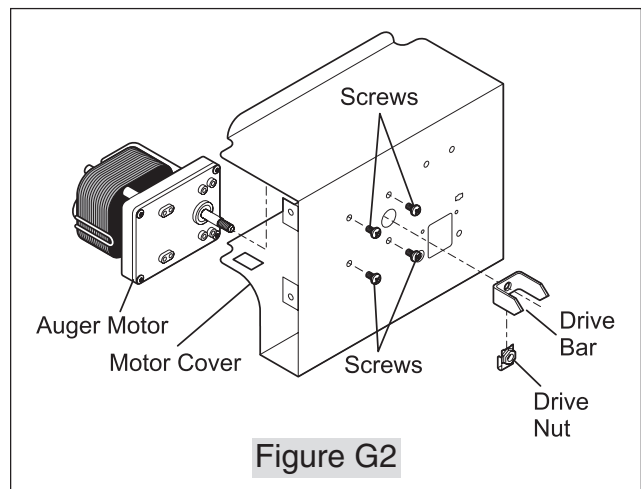
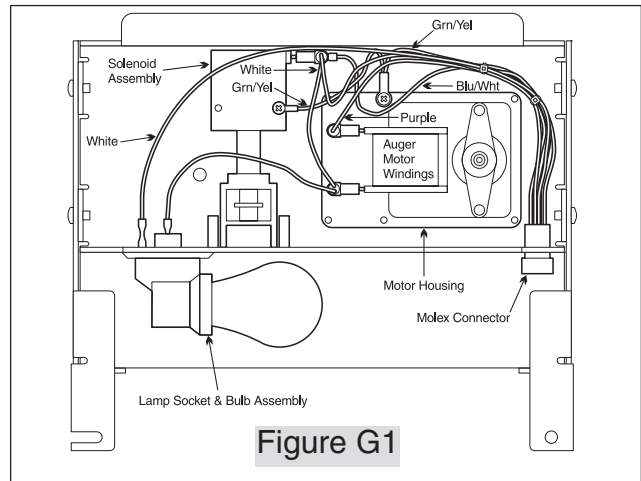

To Remove Solenoid Assembly:

1. Disconnect refrigerator from electrical supply.
2. Slide Ice Container forward and off Rail Assembly.
3. Lift up on Rail Assembly and pull forward, freeing it from mounting brackets.
4. Disconnect Molex connector located at back of Rail Assembly and pull Rail Assembly free.
5. Remove screw securing green ground wire to Solenoid Assembly on the back of Motor Cover. (See Figure G1)
6. Disconnect two (2) leads hooked to solenoid coil (Leads are blue with a white stripe and white - See Figure G1).
7. Remove four (4) mounting screws on front of Motor Cover and pull Solenoid Assembly free. (See Figure G3)
8. Replace assembly in reverse order.

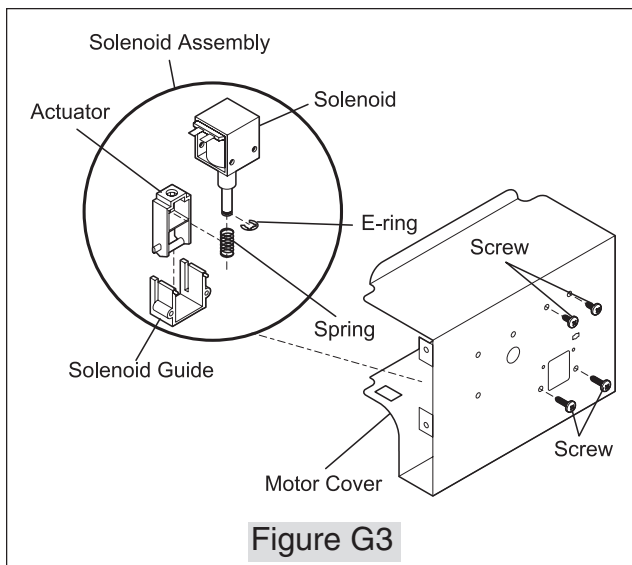

Figure G3

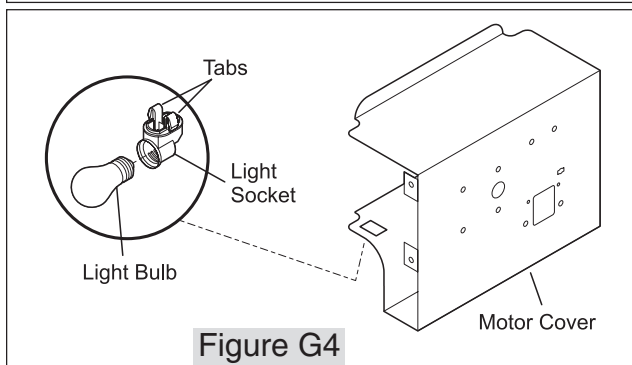

Figure G4

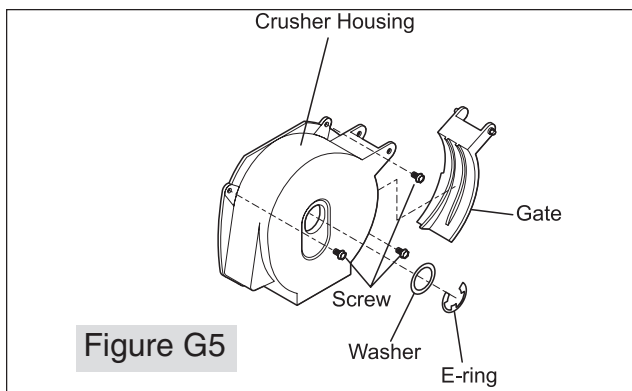

Figure G5

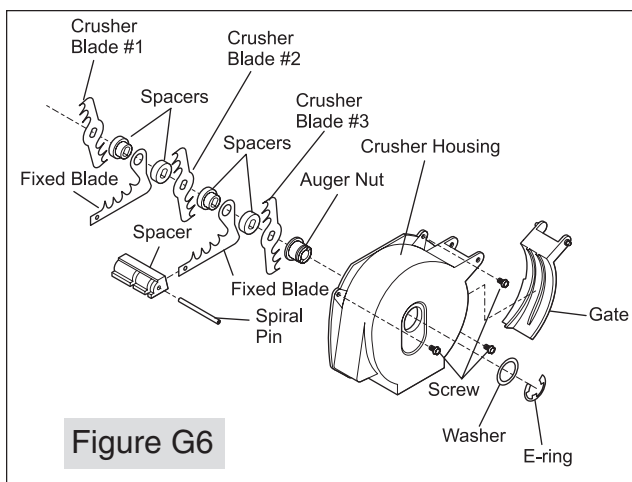

Figure G6

To Test Solenoid Assembly:

1. Read ohms value of solenoid coil using Multi meter on resistance scale. (Put test leads on terminals where blue with white stripe and white wires were disconnected from Step 6 of procedure "To Remove Solenoid Assembly").
2. If resistance reading is extremely high or low, replace solenoid coil.

To Remove Lamp Socket and Light Bulb:

1. Disconnect refrigerator from electrical supply.
2. Slide Ice Container forward and off of Rail Assembly. Remove two (2) screws mounting the rail assembly to the Evaporator Cover.
3. Lift up on Rail Assembly and pull forward, freeing it from mounting brackets.
4. Disconnect Molex connector located at back of Rail Assembly and pull Rail Assembly free.
5. Disconnect yellow and white wires connected to lamp socket located behind Motor Cover.
6. Press in on two tabs on bottom of lamp socket base and push through mounting hole. (See Figure G4)
7. Replace lamp socket in reverse order.

Ice Auger & Crusher Assembly

To remove Ice Auger & Crusher Assembly:

1. Remove four (4) screws holding Ice Container Front to Ice Container.
2. Remove two (2) screws on underside of Ice Container, holding Crusher Housing to container.
3. Remove screw holding Control Rod to container, located on underside of container.
4. Remove three (3) Hex head screws holding Crusher Housing to Front Plate. (See Figure G5)
5. Remove E-ring and washer on front of Crusher Housing. (See Figure G5)
6. Slide Control Rod free of Crusher Housing Gate.

CAUTION: The Crusher Blades are very sharp. Use protective gloves when handling Crusher Blades.

To replace Crusher Blades:

1. Remove Auger Nut to gain access to Crusher Blades. Each blade is separated by Spacer. (See Figure G6)
2. Remove Crusher Blades and Spacers until you get to one that needs replacement.
3. Replace assembly in reverse order.

ICE AND WATER DISPENSER ASSEMBLY

FEATURE LEVELS

The ice and water dispenser will have two actuators. One for water and a second for ice. (See Figure 1)

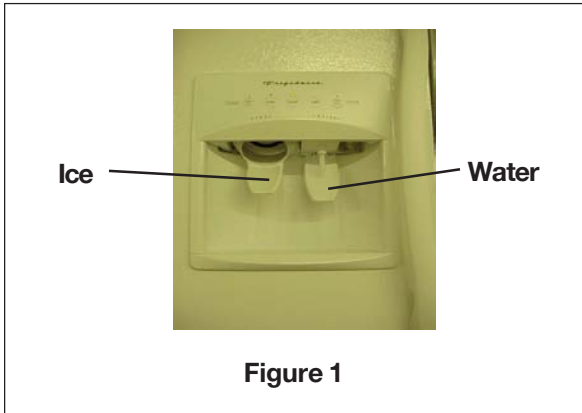

There will be different feature lay outs used on the ice and water side by sides.

Seven Selection Dispenser: (See Figure 2)

1. ACCELER FREEZE Press to drop freezer temp to -6 F for a period of 16 hours.
2. ACCELER ICE Press to increase ice production for a period of 12 hours
3. CUBE Press to get cubed ice.
4. CRUSH Press to get crushed ice.
5. LIGHT Press to turn on light in dispenser.
6. Filter RESET Press and Hold five seconds to reset light. (This light will tell you when to replace the water filter.)
7. LOCK Press to disable dispenser. (Child Lock)

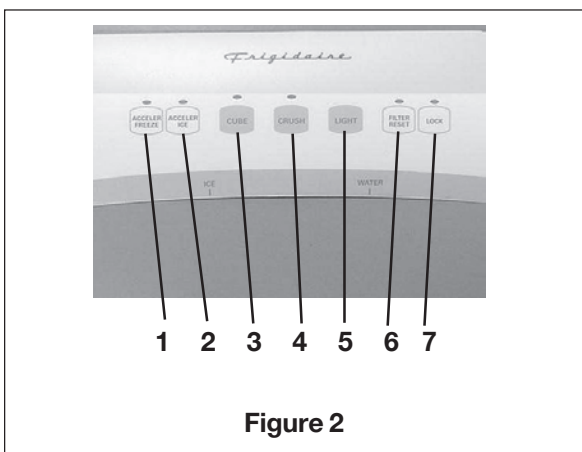

Five Selection Dispenser: (See Figure 3)

1. Extra Ice Press to increase ice production.
2. Cube Press to get cubed ice.
3. Crush Press to get crushed ice.
4. Light Press to turn on light in dispenser.
5. Filter Status Press and Hold five seconds to reset light. (This light will tell you when to replace the water filter.)

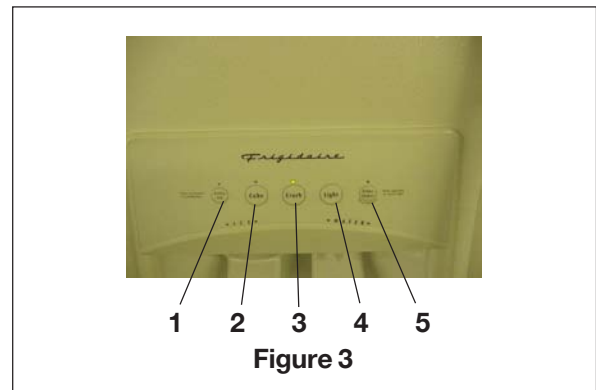

Four Selection Dispenser: (See Figure 4)

1. Cube Press to get cubed ice.
2. Crush Press to get crushed ice.
3. Light Press to turn on light in dispenser.
4. Filter Status Press and Hold five seconds to reset light. (This light will tell you when to replace the water filter.)

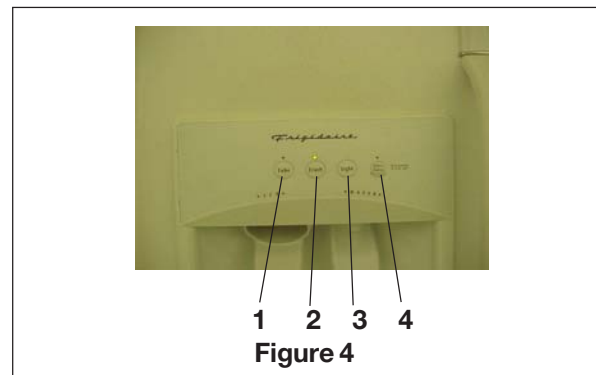

Three Selection Dispenser: (See Figure 5)

- 1. Cube Press to get cubed ice.
- 2. Crush Press to get crushed ice.
- 3. Light Press to turn on light in dispenser.

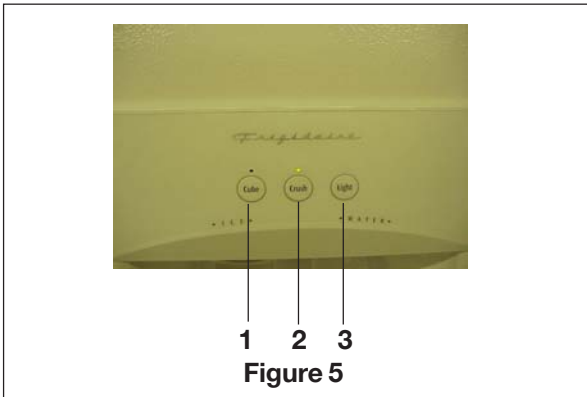
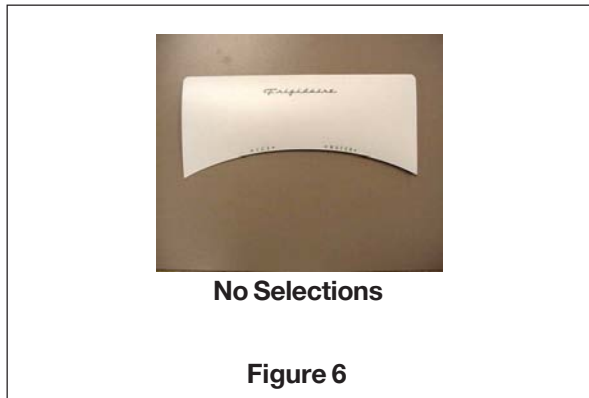

Figure 5

Ice and Water Only

The last model will not have any selections, you will get water or ice cubes depending which actuator you push your glass against. (See Figure 6)



No Selections

Figure 6

All models with a touch selection on the front will have an electronic control behind the front panel of the dispenser.

GAINING ACCESS

Two gain access to the control area you will need to pull the drip tray out first. (See Figure 7)

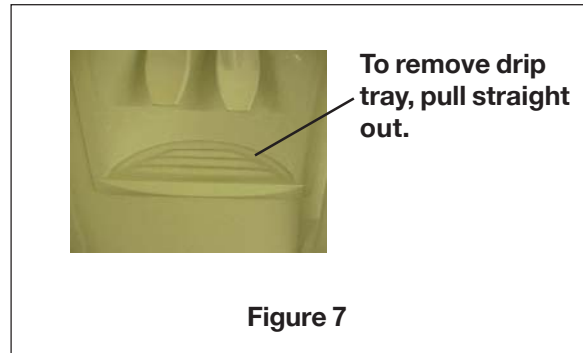

Figure 7

With the drip tray removed, remove the 3 screws at the bottom of the front panel. (See Figure 8)

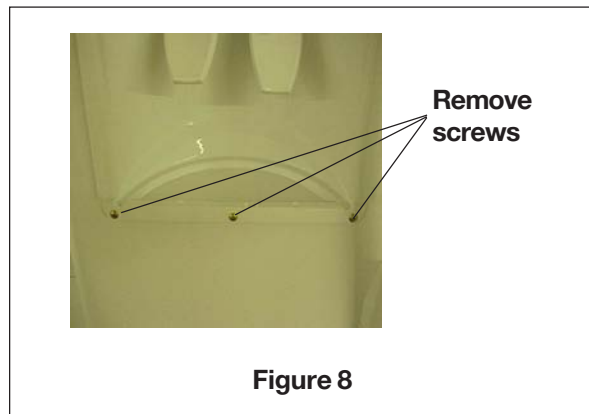

Figure 8

Lift up on the front panel, there are tabs on the top of the panel that slide into holes in the door panel. (See Figure 9)

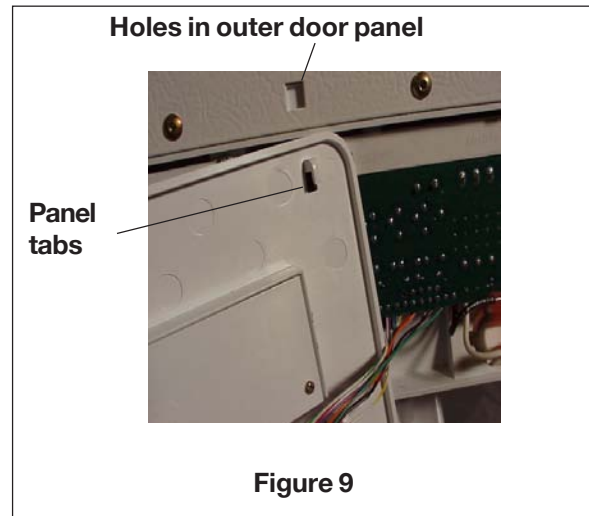
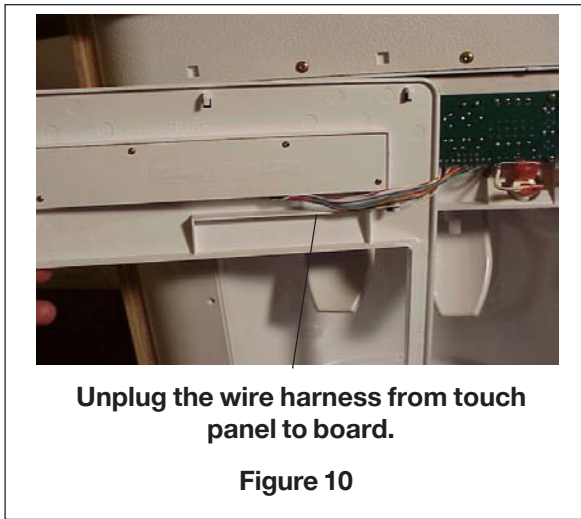
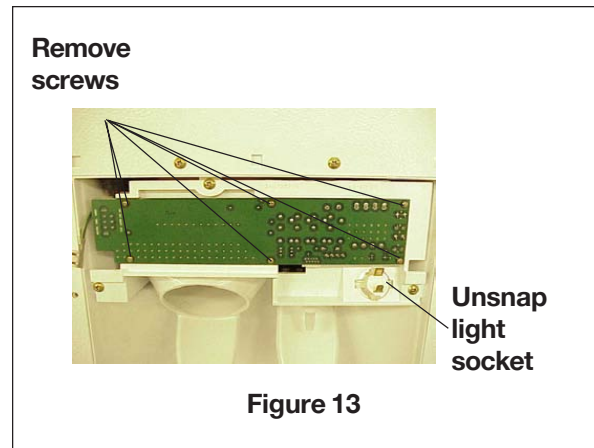

Figure 9

Swing panel out to side, being careful not to pull the wires out of the disconnect plug or the board itself.



On models with electronic control to gain access to the control, snap the light socket loose and remove the 6 small screws from the board. (See Figure 13)



Carefully unplug the wiring harness from the touch panel on the front cover. (See Figure 10) This will give you access to the control board. (See Figure 11)

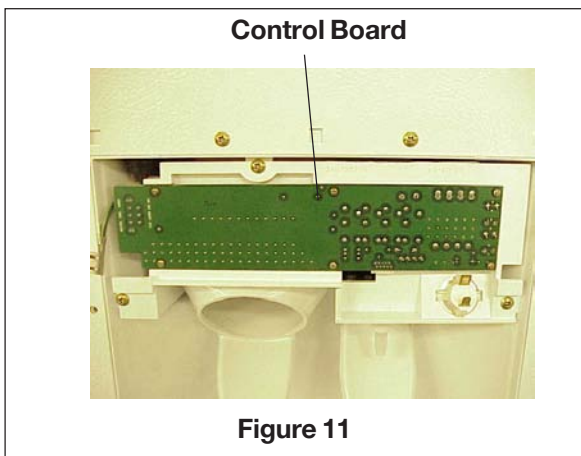

Pull board straight out of housing. Disconnect plug on left side of board. Disconnect 4 wires to dispenser actuator switches. (See Figure 14)

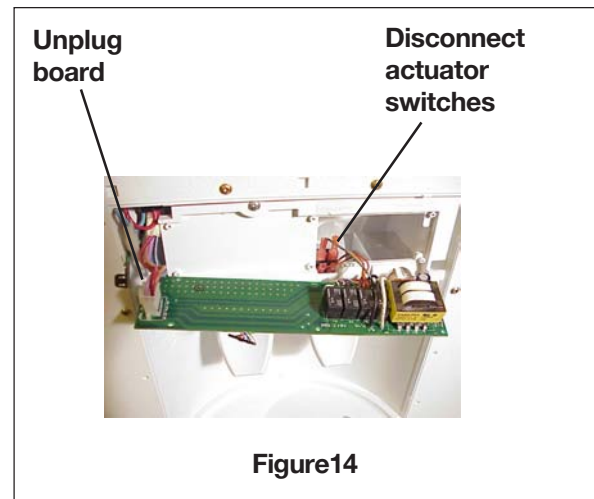

On models with no selector on the front panel, when you remove the front you can gain access directly to dispenser because you do not have a touch pad or board on dispenser. (See Figure 12)

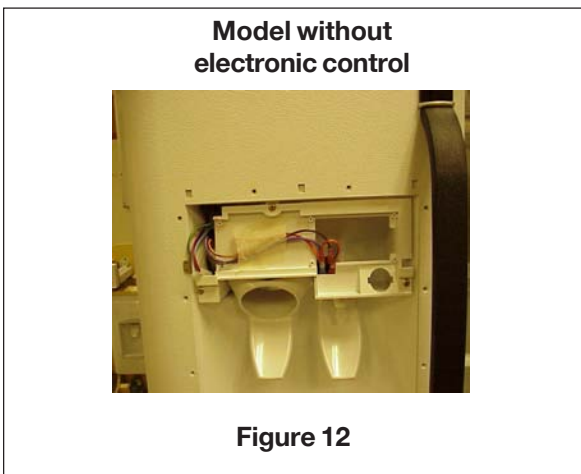

With the board removed, remove the 3 screws from the dispenser housing and pull the dispenser forward. (See Figure 15)

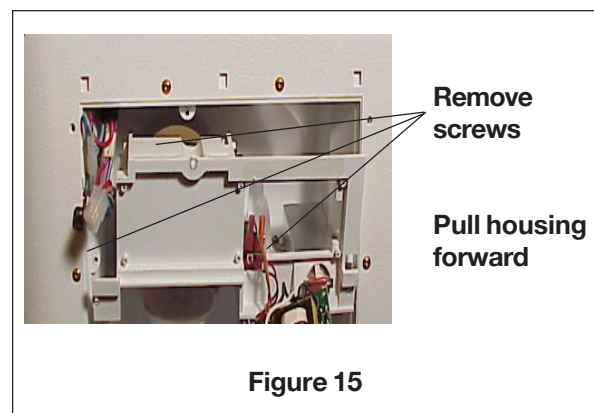

Remove water line from dispenser housing by pulling straight out. (See Figure 16)

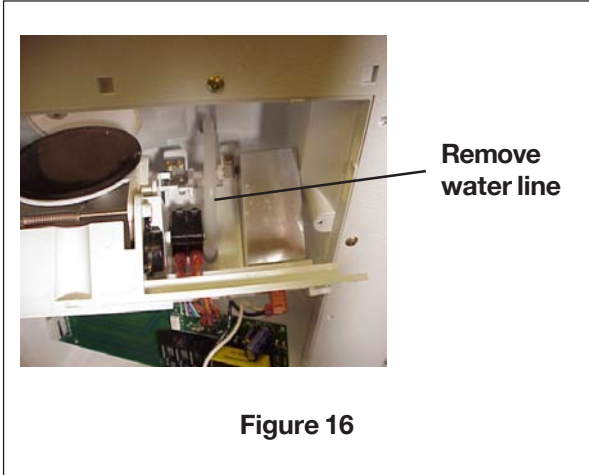

Figure 16

With the water line removed, the upper part of the dispenser is free of the freezer door panel. The main housing is part of the door panel, and is not removable. (See Figure 17)

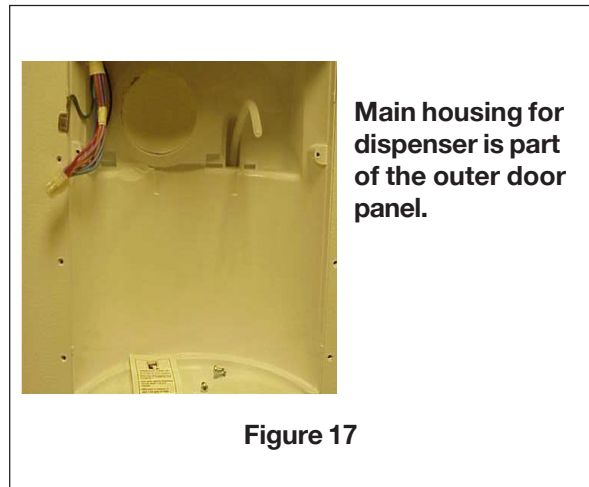

Figure 17

The ice door and actuator switches, as well as the return springs, can be serviced with the control module removed. (See Figure 18)

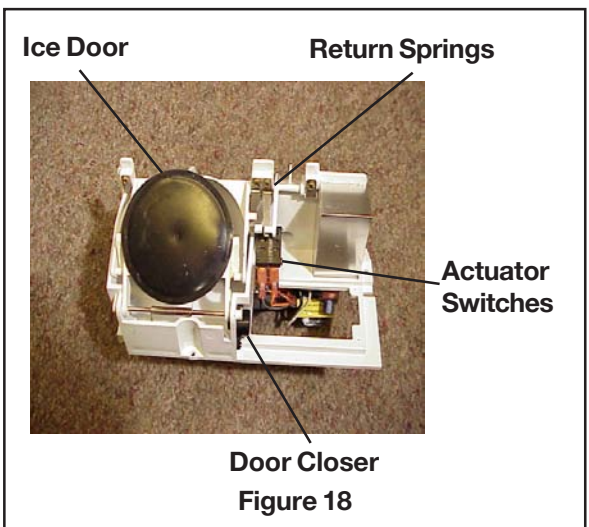
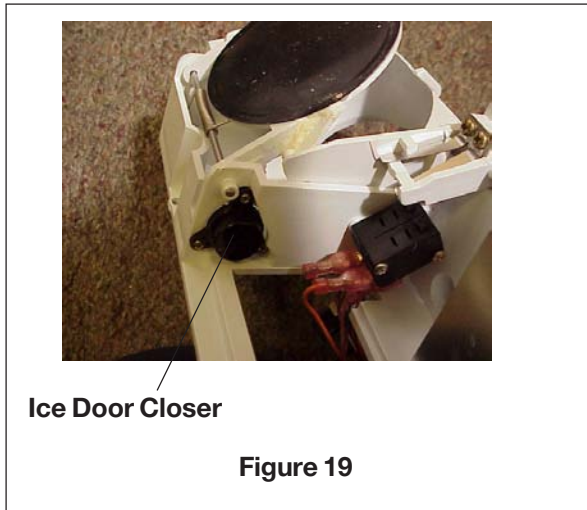

Figure 18

The door closer is mounted on the side of the housing (See Figure 19) and connected to the door arm with a gear wheel to slow the closing of the door. (See Figure 20) This allows enough time for the ice to clear the chute. The door will take approximately 20 seconds to close after the glass is removed from the actuator.



Ice Door Closer

Figure 19



Gear driver used to connect door closer to arm on door.

Figure 20

The closer can be replaced by removing 3 screws and lifting closer from housing. The door is held in place with a shaft at the top. The spring that holds the door closed and sealed against the housing is over the shaft and can be replaced by using a small punch and removing the shaft. (See Figure 21)

Use a small punch to remove shaft.



Figure 21

Tension is held against both the water and ice actuator by a stainless steel, two bladed spring mounted behind the actuator switches. The spring is held in place with 2 screws. (See Figure 22)

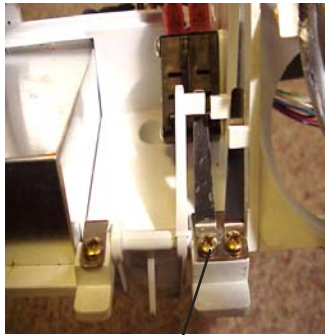

TENSION SPRING FOR ACTUATORS

FIGURE 22

The Actuators are held in place by stainless clamps at each end of the actuator and the two bladed spring in the middle. (See Figure 23) The actuators can be removed by removing the 4 screws and lifting the paddle / ice chute out of the housing.

SSpring and clamps used to hold actuators in place.

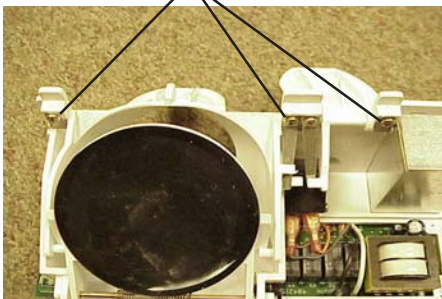

Figure 23

On models that only dispense water and ice cubes the dispenser will come apart the same way as models with a control board. The difference is there is no light in the housing and the wiring to the actuator switches is connected directly the plug in the door wiring harness. (See Figure 24)



Connector from door harness to actuator switches

Figure 24

The original heater for the ice chute and housing are foamed in place with the one piece door. It is connected to the door wiring (See Figure 25) harness by a plug coming out of the inner door panel with 2 black wires connected to it. (See Figure 25) If the heater fails, it will be necessary to install an external heater on the housing chute opening in place of the internal heater. The replacement heater will connect to the same plug as the original heater. (See Figure 26)

Check across the two black wires to test the internal chute heater.

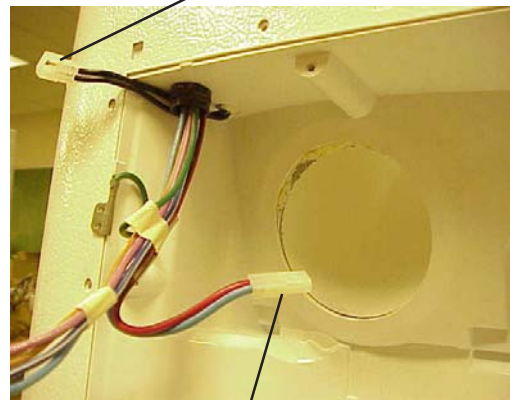

Plug for chute heater

Figure 25

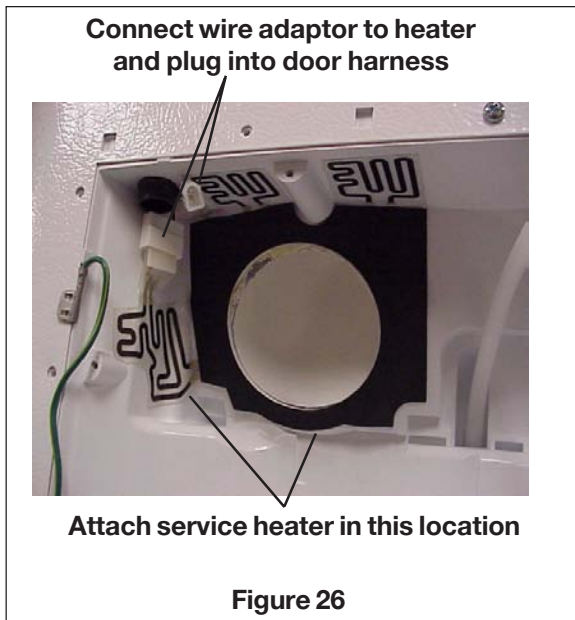

The ice door will be replaced with a new door that will have a heater in the door to prevent sticking and sweating. (See Figure 27)



The ice door with the heater can be installed in the field with the internal chute heater to control moisture on the outside of the door. This may appear in certain areas with high humidity.

FAST FREEZE - FAST ICE

The Fast Freeze (Acceler Freeze) and Fast Ice (Acceler Ice) Feature are accomplished by the use of a 2 watt electric heater on the control thermostat cap tube. (See Figure 28)

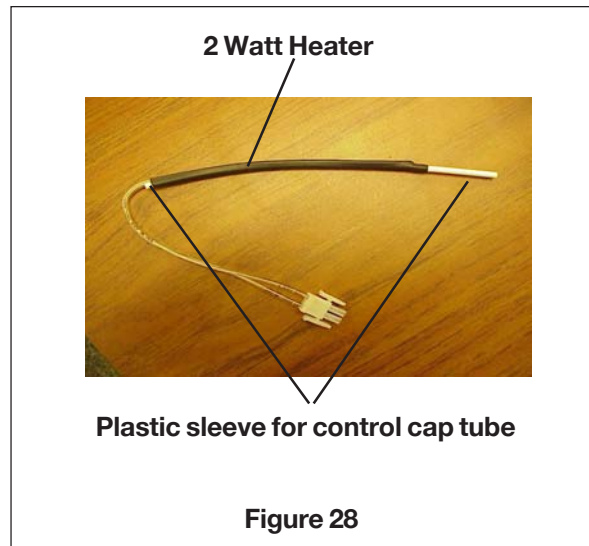

When you select the Fast Freeze (Acceler Freeze), the control board will turn the heater on 100 % of the time for a period of 16 hours, to pull the freezer temperature down to -6°F for faster freezing of food. When you select Fast Ice (Acceler Ice), the control board will cycle the heater so that it is on 50 % of the time over a 12 hour period to maintain a colder freezer temperature to increase ice production. To test the heater, unplug the connector and take a ohm reading across the terminals. You should read 6.6 K Ohms ± 10%.

The connector on the left side of the board is for the door wiring harness to plug into. (See Figure 29) This wiring harness connects with the Main Harness through the top freezer door hinge. (See Figure 30) The main harness will connect to the machine compartment harness and to the service cord. The board will then send power to other parts that operate through the board.

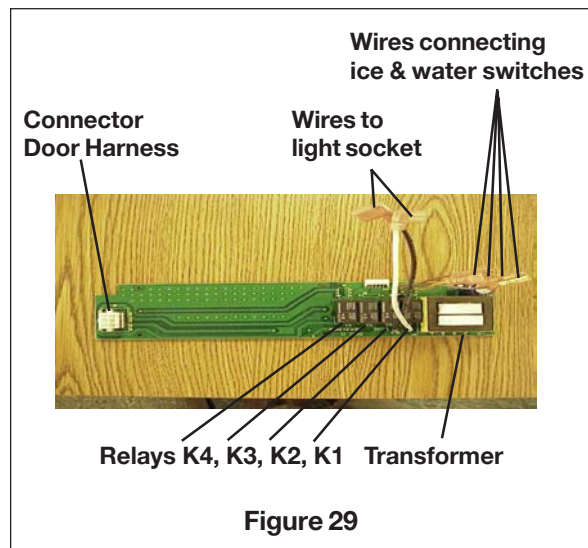

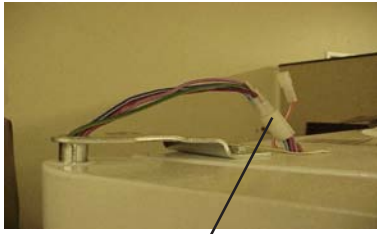

Door wiring harness will connect to the main harness at the plug under the top hinge cover.

Figure 30

The labeling is as follows:

1. NEUTRAL (one side of line to power the board)
 2. CUBE (connected to solenoid for ice cubes)
 3. AUGER (connected to auger motor)
 4. FICE (fast ice/fast freeze feature)
 5. WATER (connected to water valve yellow coil)
 6. 120 V AC (other side of line to power the board)
- (See Figure 31)

Connector on Control Board

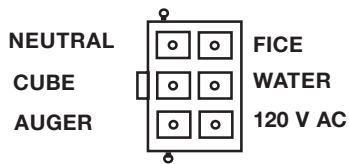

Figure 31

The relays mounted on the board are numbered.
(See Figure 32)

- K1 - Controls the Light in the Dispenser.
- K2 - Controls the Water to the Door
- K3 - Controls the Solenoid for Cube Ice
- K4 - Controls the Auger motor

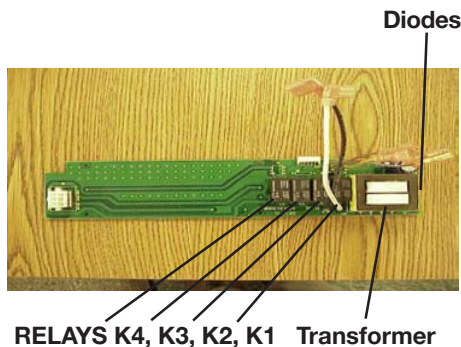

Figure 32

The power supply onto the board is 120 VAC. The transformer is mounted on the board and is used to reduce the operating voltage. (See Figure 32) There are 4 diodes mounted on the board to convert the AC current to DC current. (Touch Board - See Figure 33). The operating voltage for the control board is 8 to 13 V DC.

Control Board

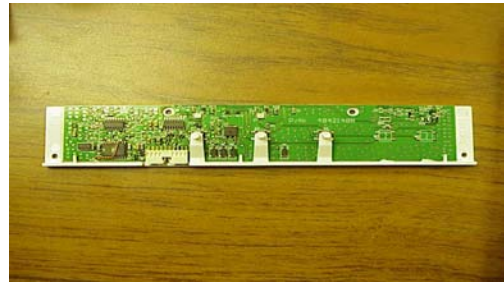

Figure 33

The control board is mounted on the front face and can be serviced by removing the front face and removing the 4 screws holding the cover over the board. (See Figure 34)



Remove 4 screws and lift up the Control Board to replace

Figure 34

Current will be carried between the power board and the control board by a wire connector (See Figure 35). You can check the wires with a ohm meter if you suspect a broken wire.

Wire connector

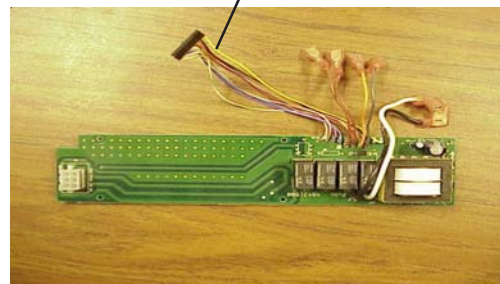

Figure 35

The test points to check for voltage are located on the face of the power board. (See Figure 36)

To do your voltage test, it will be necessary to remove the front cover, but do not disconnect the wire connector. Using a paper clip, bend a loop around the end hook on the front face and a hook in the other end of the wire. Place the second hook in the center slot used for holding the front face. (See Figure 37) Use electrical tape around the wire to prevent it from bridging some of the connection points on the power board.

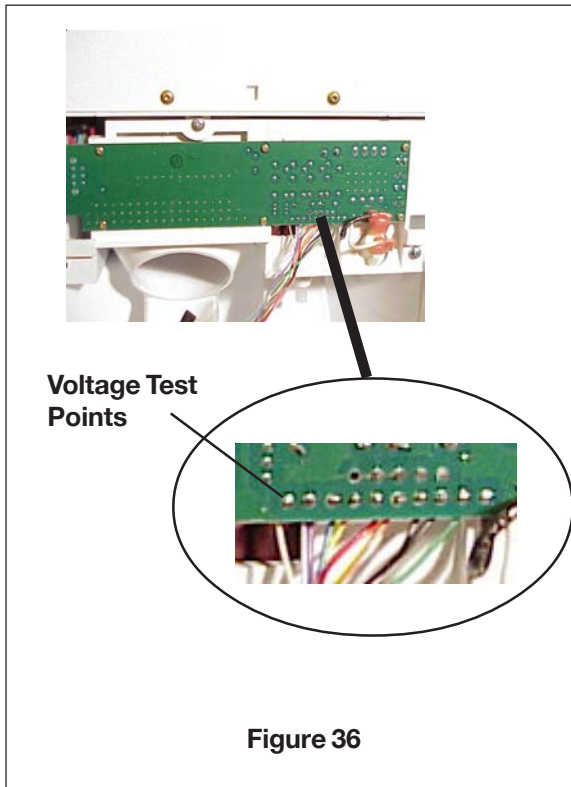

Figure 36

To test voltage, set your volt meter on DC 25 volts or higher scale. With the front removed and hanging on the wire, you can check for 8 to 12 VDC to supply voltage to the control board between the points called out in Figure 38. You will be able to make water and ice selections on the control board. Press in the actuator arm and look for your voltage drop to close the relay on the board that operates the Auger, Water Valve, Solenoid, or light.

VOLTAGE TESTING

The wire color is called out on the board but the lettering is on the relay side of the board. You would need to remove the board to see the lettering, but you can follow the wire to the connector without removing the board. Do your voltage test by following the color wire to the connection point and make your test.

Bend a piece of wire around hook on face and push into center hook slot to hold front face while testing voltage.

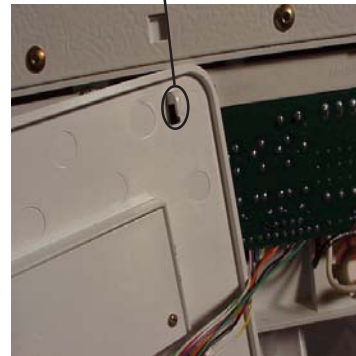
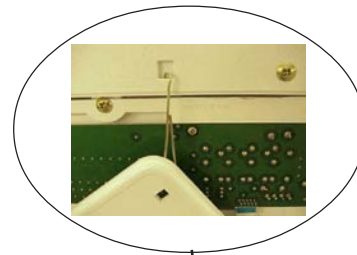

Figure 37

The power to the control board from the power board is coming in on the Green and Black wire. Green is neutral and Black is power. To do the rest of the test you will use the black wire, your readings will be 5 VDC + or - 2 until you make a selection. At the time you press the actuator your voltage will drop to less than 1 VDC on the wires listed to test the component, but the voltage will remain around 5 VDC on the remaining wires. (See Figure 38)

TO REMOVE CONTROL BOARD

To remove the control board from the front, remove the screws and lift straight up. Slide the board out from between the cover and the push buttons. When you install the new board, make certain you line the pads on the cover with the switches on the board. (See Figure 39) Reinstall front frame on freezer door making sure you plug wire harness from power board into control board before you slide the front frame into slots at top.

Test Points on Power Board wire connector

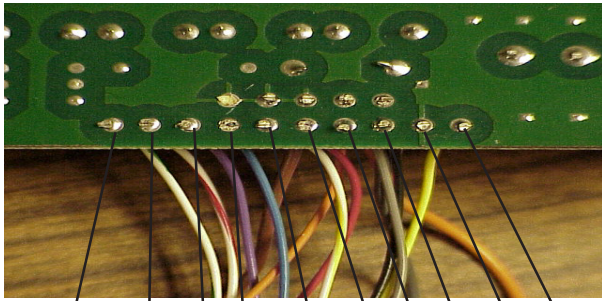

WH/GR WR/R V BL WH/Y R OR SL BK GR

Power to control GR to BK 8.9 to 12.2 VDC

Light BK to BL less than 1 VDC

Water BK to BL less than 1 VDC
BK to WH/R less than 1 VDC
BK to SL less than 1 VDC

Crushed Ice BK to BL less than 1 VDC
BK to V less than 1 VDC
BK to SL less than 1 VDC

Cube Ice BK to BL less than 1 VDC
BK to V less than 1 VDC
BK to SL less than 1 VDC
BK to WH/Y less than 1 VDC

SEE NOTE:

Color Code

GR	Green
BK	Black
SL	Silver/Gray
OR	Orange
R	Red
WH/Y	White with Yellow Trace
BL	Blue
V	Violet
WR/R	White with Red Trace
WH/GR	White with Green Trace

Figure 38

Control Board



Push Tabs

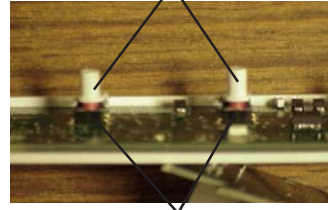

Switches

When you install control board in cover, make sure you position Push Tabs over switches on board.

Figure 39

NOTE: When you are filling a glass with water, on models without the change filter feature, you do not need to check from BK to SL.

SECTION H - WATER SYSTEM

Water Systems

Water for the ice maker and water dispenser is controlled by a dual coil valve and a single coil valve joined together as one. It's mounted just to the right of the condenser on the cabinet. Plastic tubing connects the water valve/valves to the ice maker fill tube, the water dispenser and water filter on models so equipped.

Water Valve

Next Generation models have 1 dual coil valve and 1 single coil valve (see figure H1). The green coil on dual coil valve is for the ice maker and the yellow coil is for the water dispenser. The beige coil on the single coil valve is energized for both water for the ice maker and water for the dispenser. Plastic tubing connects the primary water valve to the filter, water tank and to the secondary valve.

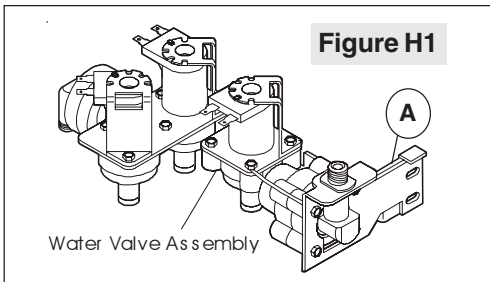

On models with a single coil valve for a primary, you have 2 diodes in the wiring harness connecting the coil of the single coil valve to the 2 coils of the dual coil valve. The diodes are used to prevent current leakage from opening both coils on the dual coil valve everytime the single coil valve is energized.

If a diode is shorted, when the single coil valve opens, current leakage through the shorted diode will cause both coils on the secondary valve to open and you'll have water going into the ice maker and coming out the door at the same time. If the the diode fails in the open position, the coil on your secondary valve will open, but the coil on the primary valve will not. As a result, you will not get water to the ice maker or dispenser. Both diodes can be checked with an ohmmeter to see if they are opened or shorted.

The coils on all water valves can be checked with an ohmmeter to see if the coils are opened or shorted. If the coil checks bad, replace the coil. If the coils check good and water pressure is between 20-120 psi, and the valve will not allow water to flow through, replace valve. It is not necessary to replace the whole valve assembly if one coil is bad. The two valves can be separated by inserting a screwdriver at point A in Figure H1.

PureSource Water Filters

Next Generation models can have either a Front Filter (see Figure H2) or a Rear Filter (see figure H3). The water filter must be changed at a minimum of twice a year. But, under certain water conditions such as large concentrations of calcium, alkali, or other particulate matter in the water, a filter may require changing more frequently. A good way to judge whether the filter needs to be replaced is when the water flow to the dispenser starts slowing down and there has been no change to the water pressure to the product. Operating water pressure should be a minimum of 20-120 psi.

PureSource2 (Front Filter)

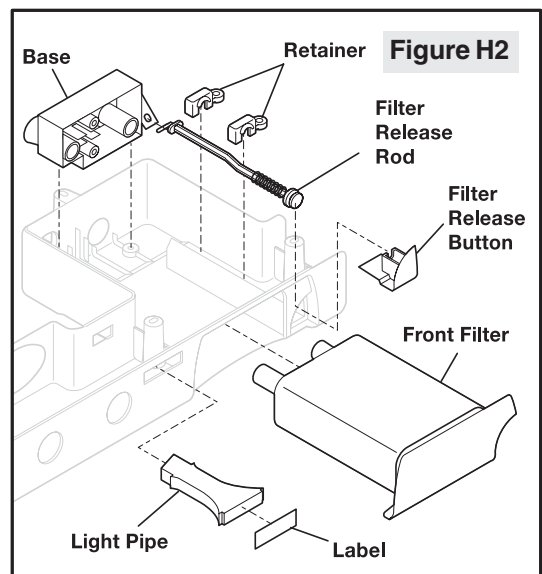

PureSourcePlus (Rear Filter)

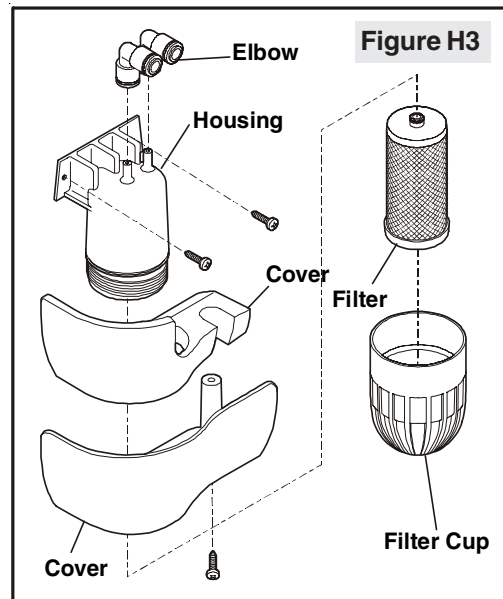

Water Tanks

Next Generation Side by Sides may have either a Water Tank Assembly or a Water Tube Assembly as shown in Figure H4.

The water line from the primary water valve (single coil valve) goes behind the trim located on the right side of the inside food compartment liner to the water filter. From the water filter the line goes to the water tank, then to the secondary water valve (two coil valve). The two coil valve dispenses water to the ice maker and to the dispenser in the door. By filling the ice maker for the water tank you will get chilled water to the ice maker helping to increase ice production. See Figures H5, H6 and H7 for water system flow diagrams.

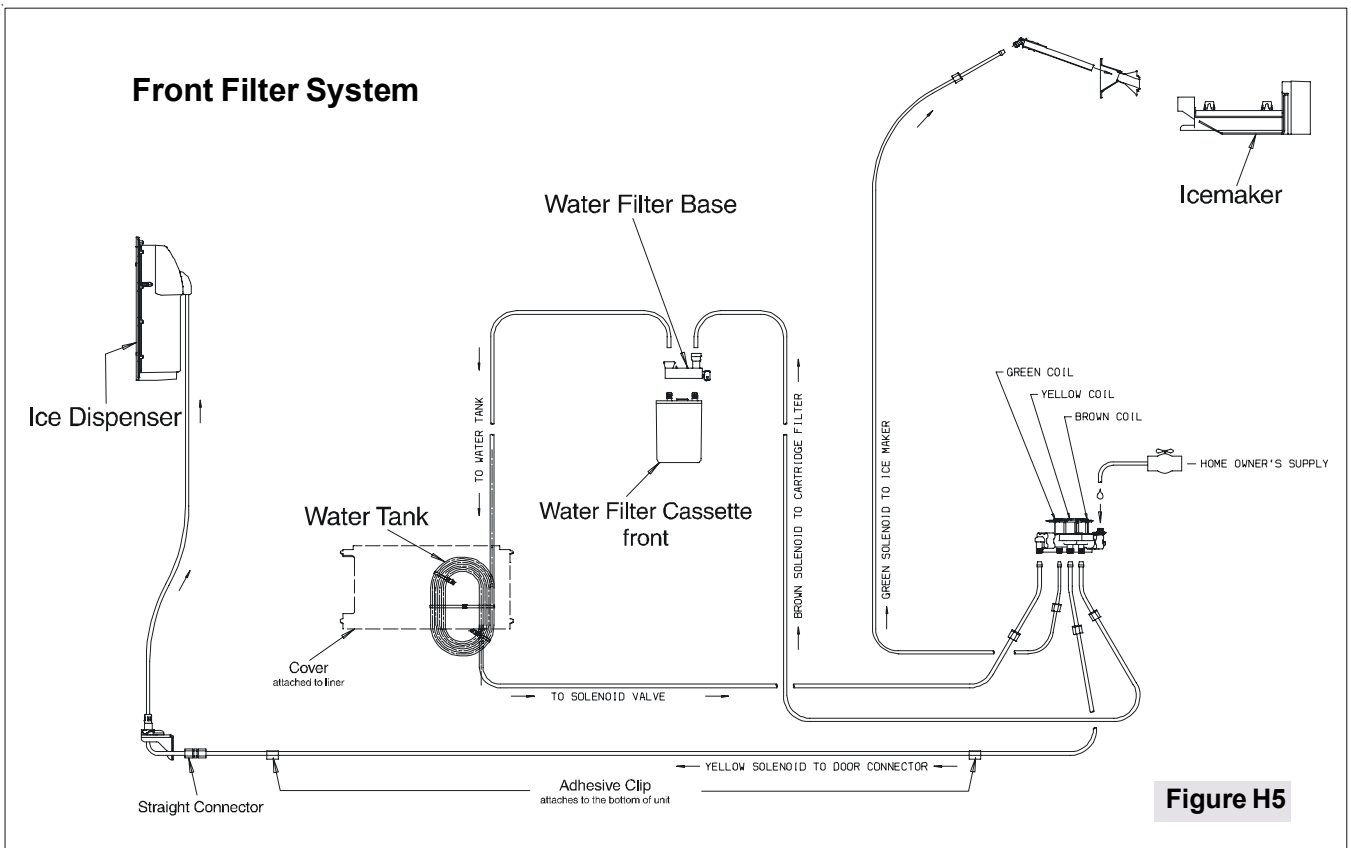
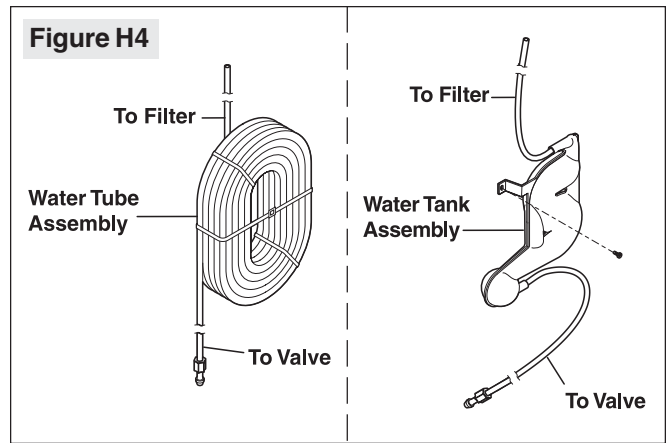

Figure H5

Rear Filter System

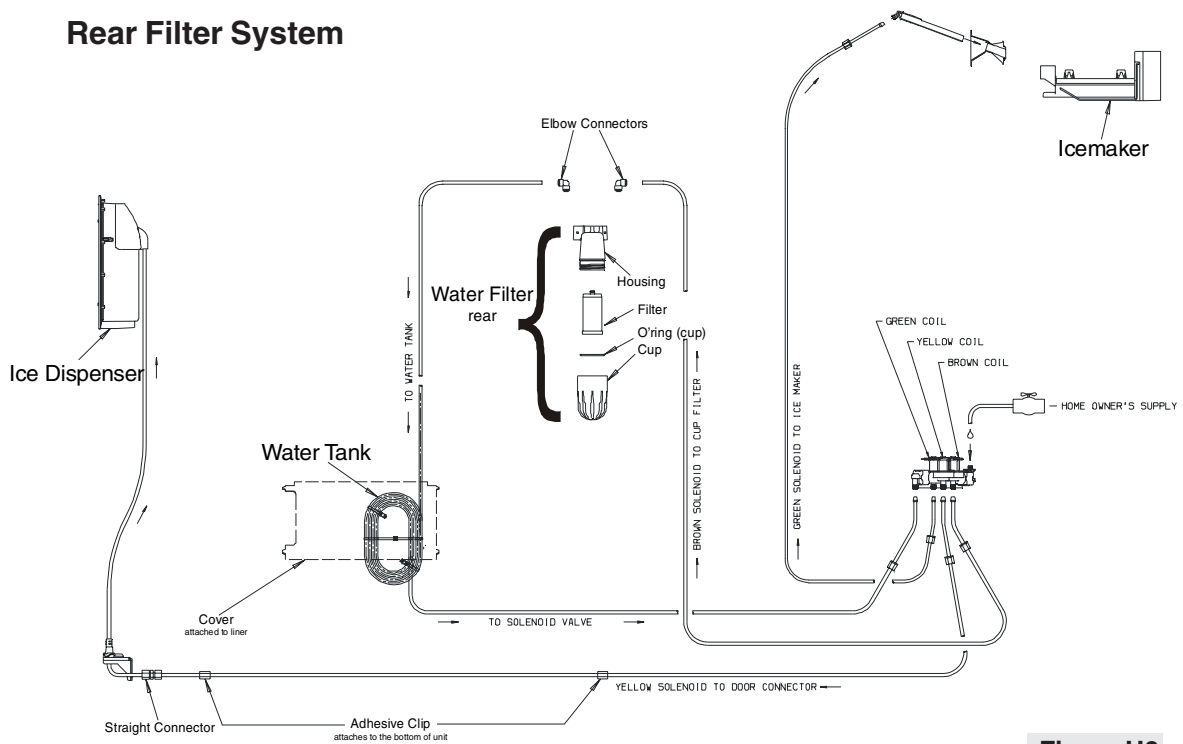

Figure H6

No Filter System

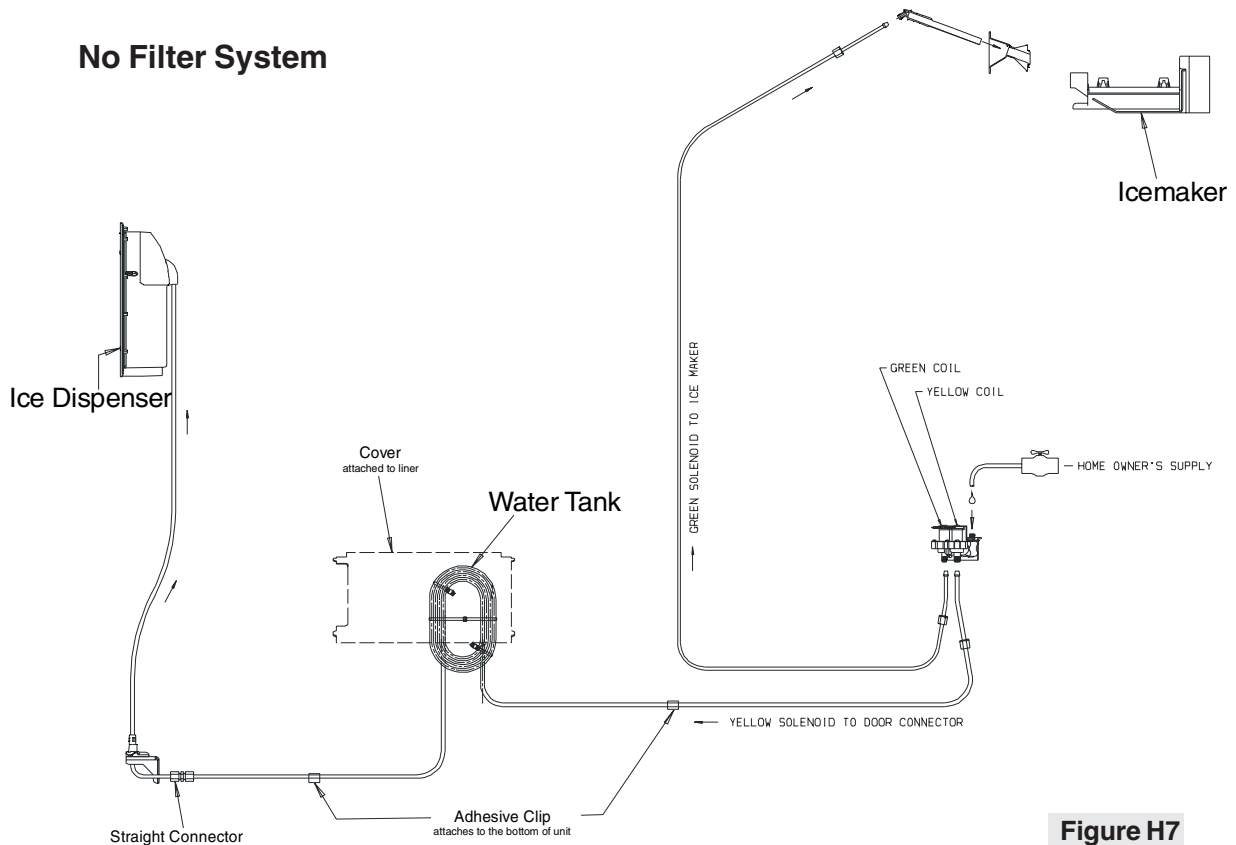

Figure H7

TO TEST THE WATER FILL SYSTEM

The wiring harness has two diodes in the line between the fill switch on the ice maker and the green coil of the secondary water valve, as well as the water switch or relay on the freezer door and the secondary valve. The diodes are part of the wiring harness. (See wiring diagram Figure G10).

If the diodes fail open, the primary valve will not open for ice and/or water depending on what diode is open. The open diode will not effect the coil on the secondary valve, the secondary valve will open but if the primary valve does not open you will not supply water to the secondary valve.

Resistance Check	To test the diodes you can use a ohm meter with at least a 10K ohm or higher scale. Take a reading across the diode, reverse your leads and take another reading, the diode should check 10 times higher in one direction than the other.
Voltage Check	You can also use a volt meter to check the circuit. Connect a volt meter to the valve coil of the primary valve, and connect a second volt meter to the green coil of the secondary valve, if the problem is with the ice maker, or the yellow coil of the secondary valve if the problem is with the water dispenser.
Digital Meter	If you are using a good meter you will read between 0 and 10 volts with a open diode on the primary valve but you will have over 90 at the secondary.
Voltage Drop From Heater	In checking the voltage on a ice maker fill you must keep in mind that the coils of the water valves are in series with the heater on the ice maker. The resistance of the heater will cause a drop in voltage. Example, if you have 110 to120 at the outlet with the product running, between 92 and 101 will be present at the green coil of the secondary valve.
Valve Coil	The production valves use a 20 watt coil to open the valve. This should open the valve down to about 90 volts at the green coil of the secondary valve. If the voltage is lower than 90 but above 80 you can install a 50 watt service coil (Part Number 5304401081) Keep in mind you must replace the coil on the primary and the green coil on the secondary valve to resolve the problem.
Voltage Readings Are Different Between Primary And Secondary Valve Coils	If you are getting 10 volts or less at the primary valve but you are getting 85 to 100 at the secondary you have a bad diode. If you are getting 48 to 58 volts at the primary valve and 90 or higher at the secondary this is normal. With the current flowing to the primary valve coil through the diode you are getting 30 cycle instead of 60 cycle current at the coil of the primary valve. Because of this your meter will only read about 1/2 the voltage that is going to the coil.
No Water at Door	If the ice maker is operating but you can not get water out the door the test and operation of the diode is the same as for the ice maker except for the voltage readings. On the water side you should read the same voltage at the coil of the secondary valve as you have at the outlet. On the primary valve the voltage should read 60 to 70 V AC. If the voltage is low at the primary but good at the secondary, you have a bad diode. If the voltage is low at both the primary and secondary you have a bad connection or a bad switch in the door dispenser.
Diode Kit	If you have a problem with the diodes,order the diode kit (part number 5304418384). (See Figure H8.) The diodes are part of the wiring harness for the machine compartment.
Checking Water Valves	If you do your voltage checks and find you have the correct voltage at the coils and the valve is not letting water through, replace the valve. To see which valve is bad, disconnect the water line from the filter to the secondary valve at the inlet of the secondary valve. Place the line in a bucket.
Ice Maker Valve (Green Coil)	Run the ice maker through a fill and see if water will pass through the valve and the filter into the bucket. If it does replace the secondary valve. If it does not, remove the primary valve, disconnect the outlet line from the primary valve and run the ice maker through a fill. If still no water, replace the primary valve. If water is coming through, replace the water filter.
Chilled Water Valve (Yellow Coil)	Place a glass against the actuator and push in to see if water will pass through the valve and the filter into the bucket. If it does, replace the secondary valve. If it does not, remove the primary valve, disconnect the outlet line from the primary valve and place a glass against the actuator and push. If still no water, replace the primary valve. If water is coming through, replace the water filter.

**Low/No Voltage
At Coil(s)**

One point we need to cover in our testing is good connections at all points in the ice and water wiring. There are a number of connections in the wiring of a refrigerator. On the ice maker, the wiring runs through the plug by the condenser fan motor up to the ice maker, back down to the same plug and into the diode harness. On the water dispenser the wiring runs from the plug by the condenser fan motor to the plug at the bottom of the freezer door up to the dispenser and back down through the same plugs to the diode harness. A bad connection at any of the plugs or wire terminals can stop the valves from operating. One of the problems we have found is at the connector on the water valve coils is pushed on with the valve terminal over top the terminal in the plug. (See Figure H9.)

The Diode kit part number is 5304418384, this kit will contain:

- (2) Crimp Connectors
- (2) Pieces of heat shrink
- (1) Instruction sheet
- (1) Diode Harness

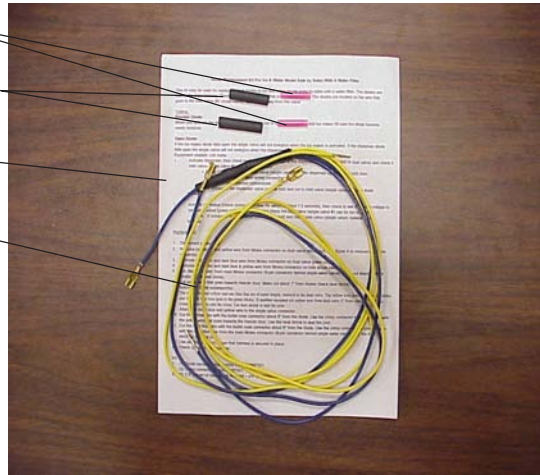
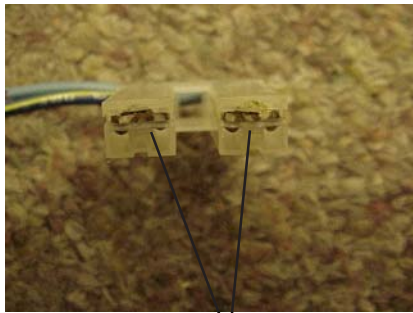
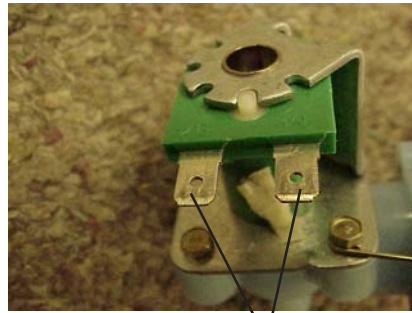

Figure H8



Terminals in Connector



Terminals on Coil



Terminal on Coil is Installed Over
Top of Terminal on Left Side of Plug

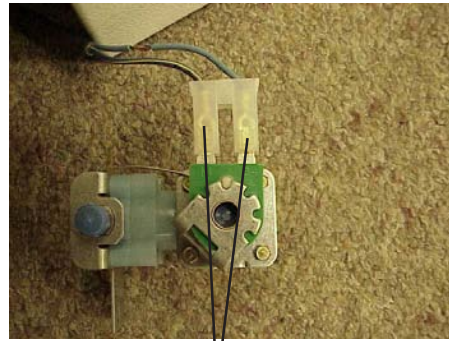

Terminals and Plug
Installed Correctly

Figure H9

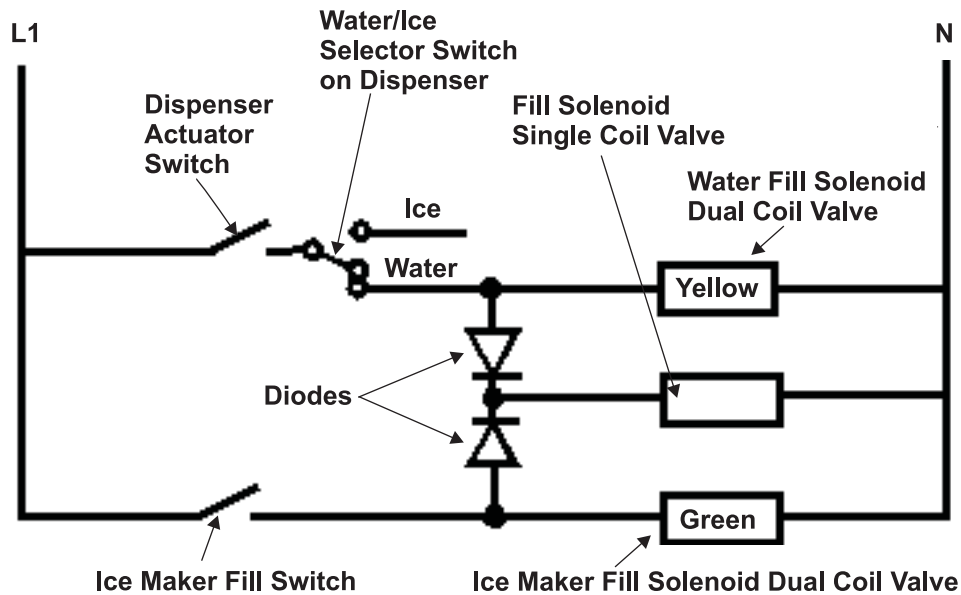

VOLTAGE READINGS AT GREEN COIL OF SECONDARY VALVE

When Ice Maker is Filling:

Voltage at Outlet	Voltage at Coil	
120 VAC	100 ± 10% VAC	Normal
100 VAC	85 ± 10% VAC	Normal at 105 VAC (Will require use of 50 watt coil)
100 - 120 VAC	20 - 76 VAC	Bad connection, Fill Switch, or Heater in Ice Maker.

VOLTAGE READING AT YELLOW COIL OF SECONDARY VALVE

When Filling A Glass With Water:

Voltage at Outlet	Voltage at Coil	
120 VAC	119 ± 10% VAC	Normal
100 VAC	99 ± 10% VAC	Normal
100 - 120 VAC	0 - 90 VAC	Bad connection or bad Fill Switch

VOLTAGE READING AT COIL OF PRIMARY VALVE

When Ice Maker is filling:

Voltage at Outlet	Voltage at Coil	
120 VAC	56 ± 10% VAC	Normal
100 VAC	48 ± 10% VAC	Normal
100 - 120 VAC	10 - 43 VAC	Bad connection, Fill Switch, or Heater in Ice Maker
100 - 120 VAC	0 VAC	Open Diode (if current is normal at secondary coil)

NOTE: You must remember that with the current flowing to the Primary Valve Coil through the Diode, you are getting 30 cycle instead of 60 cycle current at the coil of the Primary Valve. Because of this, your volt meter will only read about 1/2 the voltage that is going to the coil. The change in the cycle of current does not effect the efficiency of an electromagnetic coil.

Figure H10

 **Electrolux**
