

SXS - 25 DISPENSER-FILTER

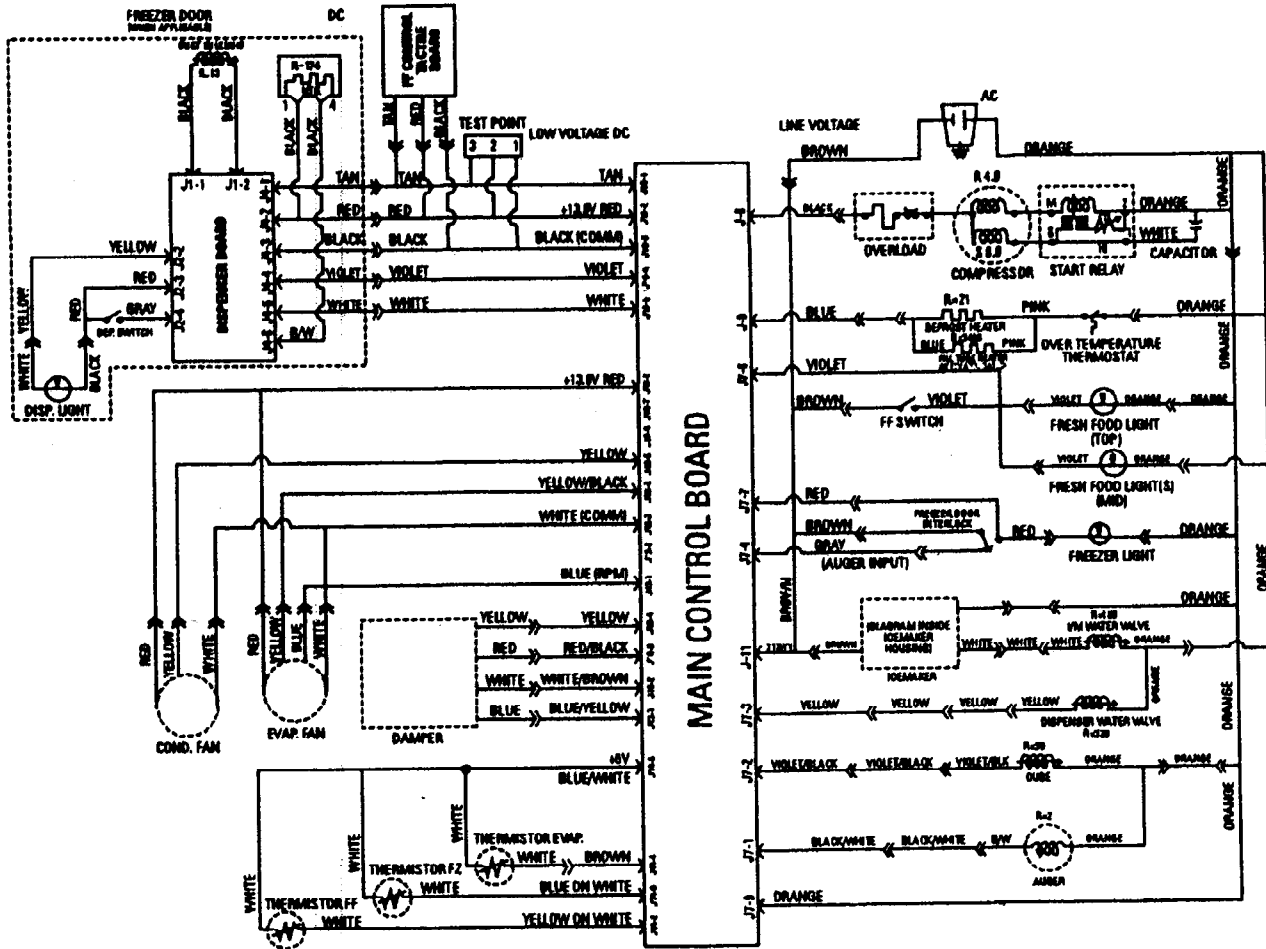

197D4106P068

197D4106P068

197D4106P068

197D4106P068

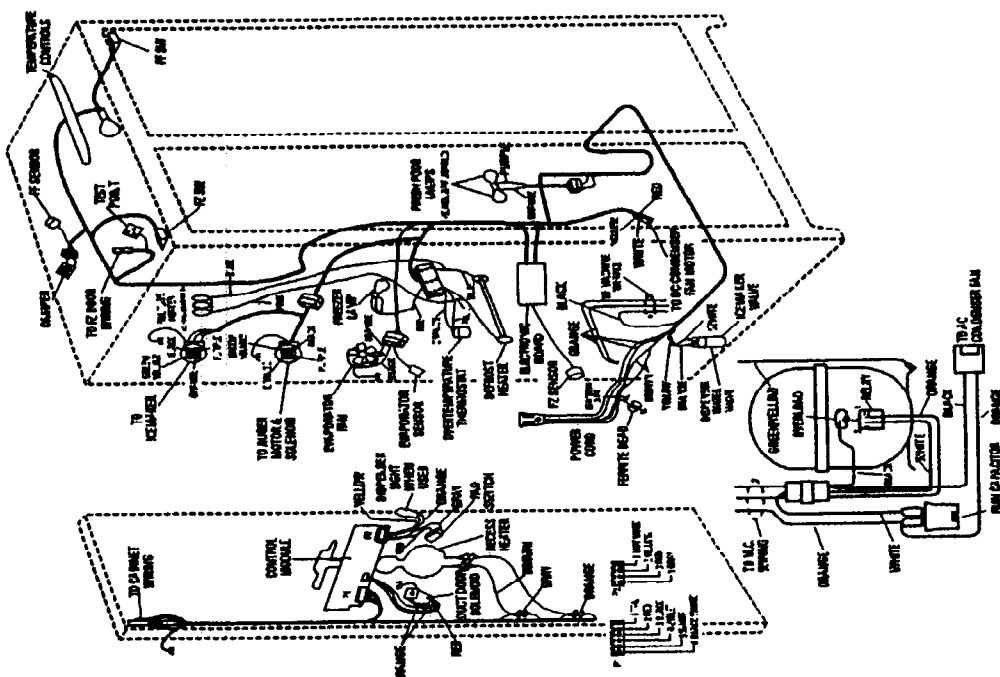

**DISCONNECT POWER CORD BEFORE SERVICING**  
**IMPORTANT - RECONNECT ALL GROUNDING DEVICES**  
 All parts of this appliance capable of conducting electrical current are grounded. If grounding wires, screws, straps, clips, nuts or washers used to complete a path to ground are removed for service, they must be returned to their original position and properly fastened.

**IMPORTANT SAFETY NOTICE**  
 This information is intended for use by individuals possessing adequate backgrounds of electrical, electronic and mechanical experience. Any attempt to repair a major appliance may result in personal injury and property damage. The manufacturer or seller cannot be responsible for the interpretation of this information, nor can it assume any liability in connection with its use.

**ELECTRICAL SPECIFICATIONS**

Thermistor calibration: kilo-ohm resistance..... @ 0°F 62.79  
 @ 37°F 24.48  
 @ 77°F 10.00  
 Defrost Control..... adaptive system  
 Overtemperature Thermostat..... 140-110°F

**INSTALLATION**

Clearance must be provided for air circulation  
 AT TOP..... 1"  
 AT SIDES..... 0.13"  
 AT REAR..... 1"

**ELECTRICAL RATING**

Maximum Current Leakage.....0.75 mA.  
 Maximum Ground Path Resistance..... 0.14 Ohms

**NO LOAD PERFORMANCE**

Control Position 5/5 and Ambient of 65°F - 90°F  
 Fresh Food, °F..... 34-41  
 Frozen Food, °F..... (-3) -3  
 Run Time, % @ 65 Ambient..... 23-35%  
 Run Time, % @ 90 Ambient..... 48-80%

**REFRIGERATION SYSTEM**

Refrigerant Charge (R134a).....4.75 ounces  
 Compressor.....900 BTU/hr  
 Minimum Compressor Capacity.....21 inches  
 Minimum Equalized Pressure  
 @ 70°F..... 55 PSIG  
 @ 90°F..... 63 PSIG

**AIR FLOW**

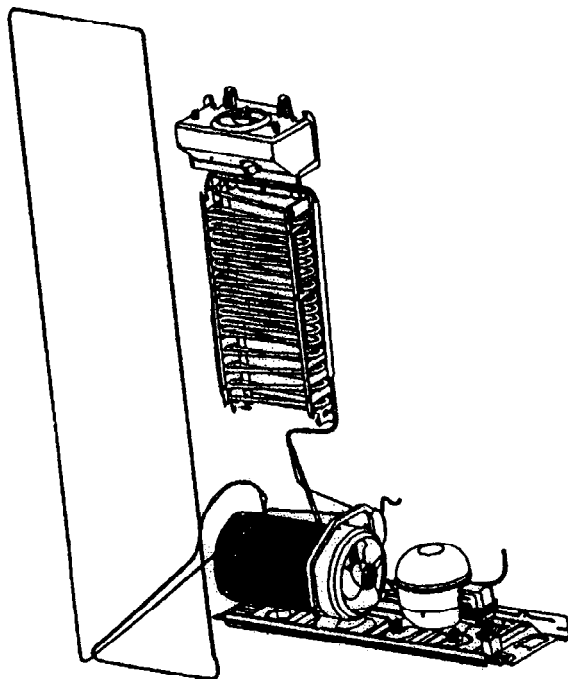
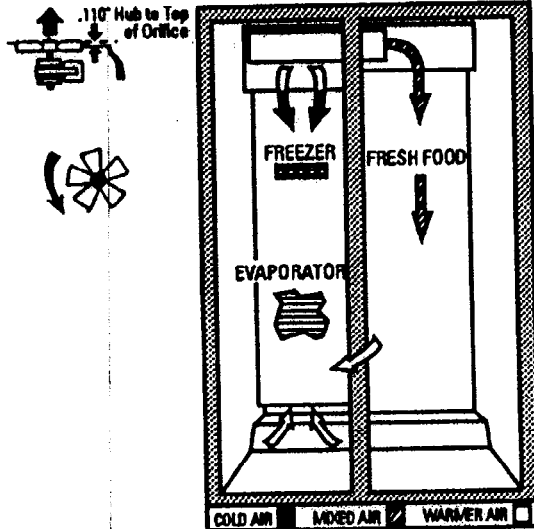

197D4106P068

197D4106P068

197D4106P068

197D4106P068