



<http://biz.lgservice.com>

# REFRIGERATOR

# SERVICE MANUAL

**CAUTION**  
BEFORE SERVICING THE UNIT,  
READ THE SAFETY PRECAUTIONS IN THIS MANUAL.

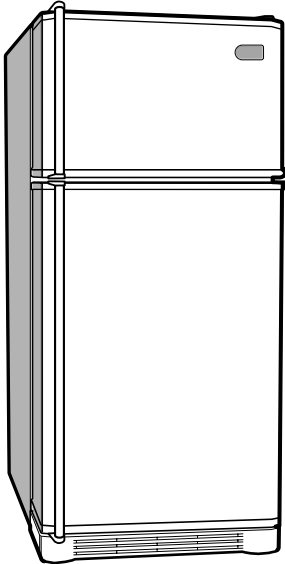

**MODEL : LRTBC1825T**  
**LRTBC2025T**

**COLOR: TITANIUM**

# CONTENTS

---

<b>SAFETY PRECAUTIONS</b> .....	<b>2</b>
<b>SERVICING PRECAUTIONS</b> .....	<b>3</b>
<b>SPECIFICATIONS</b> .....	<b>4</b>
<b>PARTS IDENTIFICATION</b> .....	<b>5</b>
<b>DISASSEMBLY</b> .....	<b>6-7</b>
DOOR.....	6
DOOR SWITCH.....	6
THERMOSTAT .....	6
FAN AND FAN MOTOR.....	7
DEFROST CONTROL ASSEMBLY.....	7
LAMP .....	7
CONTROL BOX-R.....	7
<b>ADJUSTMENT</b> .....	<b>8</b>
COMPRESSOR.....	8
POSITIVE TEMPERATURE COEFFICIENT-STARTER.....	8
OVERLOAD PROTECTOR .....	9
<b>CIRCUIT DIAGRAM</b> .....	<b>9</b>
<b>TROUBLESHOOTING</b> .....	<b>10-15</b>
COMPRESSOR AND ELECTRIC COMPONENTS .....	10
POSITIVE TEMPERATURE COEFFICIENT AND OVERLOAD PROTECTOR .....	11
DEFROST TIMER .....	11
OTHER ELECTRIC COMPONENTS .....	12
SERVICE DIAGNOSIS CHART.....	13
REFRIGERATING CYCLE .....	14-15
<b>OPERATION PRINCIPLE AND REPAIR METHOD OF ICE MAKER</b> .....	<b>16-27</b>
<b>EXPLODED VIEW</b> .....	<b>28-31</b>
<b>REPLACEMENT PARTS LIST</b> .....	<b>32-</b>

# SAFETY PRECAUTIONS

---

Please read the following instructions before servicing your refrigerator.

1. Check the refrigerator for current leakage.
2. To prevent electric shock, unplug before servicing.
3. Always check line voltage and amperage.
4. If you use any kind of appliance, check regular current, voltage, and capacity.
5. Don't touch metal products in the freezer with wet hands. This may cause frostbite.
6. Prevent water from following onto electric elements in the mechanical parts.
7. Close the top door before opening the bottom door. Otherwise, you might hit your head when you stand up.
8. When tilting the refrigerator, remove any materials on the refrigerator, especially the thin plates (ex. Glass shelf or books.)
9. When servicing the evaporator, wear cotton gloves. This is to prevent injuries from the sharp evaporator fins.
10. Leave the disassembly of the refrigerating cycle to a specialized service center. The gas inside the circuit may pollute the environment.

# SERVICING PRECAUTIONS

## AIR RECHARGING IN COMPRESSOR

Test the refrigeration system connecting it electrically before refilling operation. It is necessary to ascertain the function of the motor-compressor and identify the defects immediately. If defects have been found, empty the old system of possible R-134a residue by breaking off the end of the extension piece at its narrow point. (Figure 1) Replace the filter and any damaged components. Unsolder and pull off the piece remaining inside the service tube and then attach a complete extension with male Hansen and at last, solder it to the same tube again. (Figure 2)

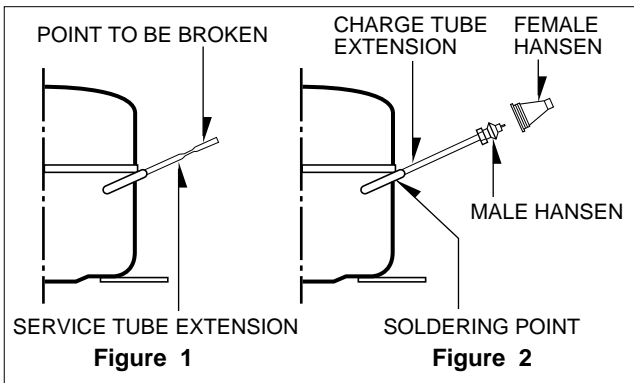

It is necessary to execute the soldering operation with valve open so that the fumes caused by oil residue can come out freely without blowholes between two tubes during the heating of the point to be soldered. The extension fitted with the male Hansen is connected to the female fitting of the vacuum pump tube. (Figure 3)

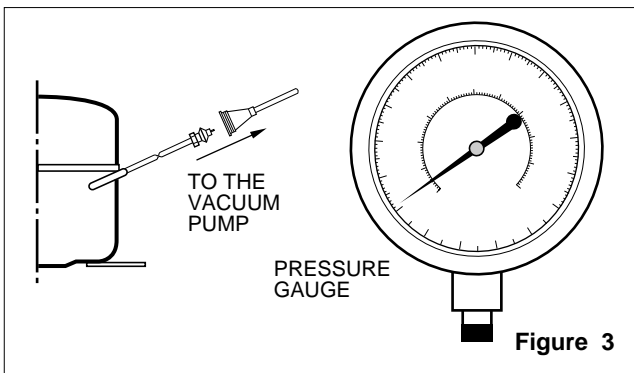

Air evacuating from the system begins as soon as the pump starts. The refrigeration system must be kept under vacuum until the reading on the low-pressure gauge indicates vacuum (0 absolute, -1 atm., -760 mm hg). In any case it is advisable to keep the pump running for about 30 minutes. (Figure 3)

If considerable leakage occurs, it will be necessary to stop the vacuum pump and to add a small quantity of Freon to the system. If vacuum should not be obtained (pressure gauge can't fall to 1 atmosphere), start the refrigeration unit and find the leakage with special leak-finder. When the defective soldering point is visible, repair it after opening the extension tube valve and reestablishing the normal outside pressure inside the group.

Because the melted alloy is sucked into the tubes and blocks them, the pressure must be rebalanced when vacuum is in the system when soldering. As soon as the

vacuum operation is over, add the quantity in grams of R-134a to the refrigeration system. Remember that every system has an exact quantity of R-134a that can be added with a tolerance of  $\pm 5$  grams. (Figure 4)

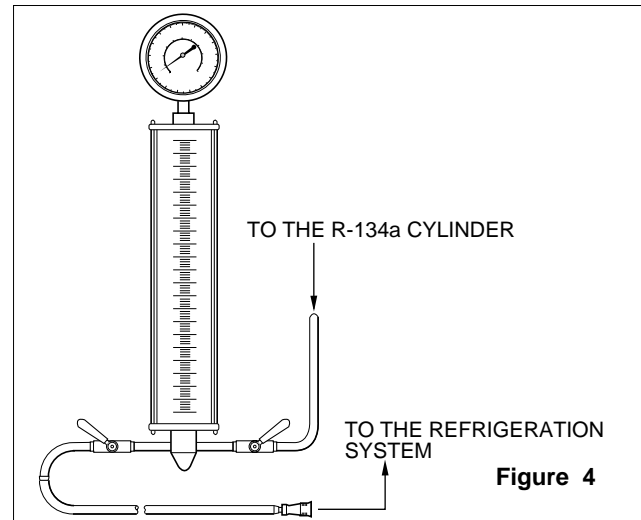

Before performing this operation (if the vacuum pump and refilling cylinder are connected), make sure that the valve placed between the vacuum pump and the refilling tube is closed in order to keep the Freon for addition to the system. (Figure 5)

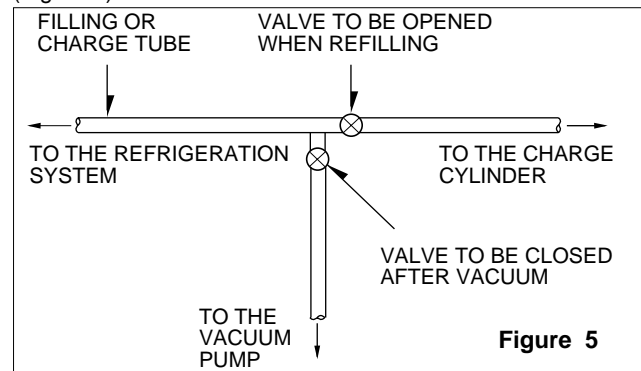

In addition, check the graduated scale on the cylinder for the quantity of R-134a to be added, for example, if we have 750 grams of Freon in the cylinder and must add 140 grams to the group, this amount will be reached when R-134a has dropped to 610 grams, remembering that the indicator shows a lower limit of meniscus. Do this after choosing the scale corresponding to the gas pressure different scales reported as the same gas pressure indicated by the pressure gauge on the top of the column.

To make R-134a flow into the system, open the valve placed at the base of the cylinder connected to the filling tube. The amount of Freon cannot be added to the system all at once because it may cause a blocking of motor-compressor. Therefore, proceed by adding the original quantity of about 20-30 grams and close the valve immediately.

The pressure rises and the motor compressor must start sucking the gas and lowering the pressure again. Open the valve again, maintaining the same manner until reaching to the quantity of R-134a established for the system being charged. When the system is running, the suction pressure must be stabilized between 0.30 to 0.6 (0.10 to 0.4) atmosphere.

# 1. SPECIFICATIONS

## 1. Ref. No.: LRTBC1825T

ITEMS	SPECIFICATIONS
DOOR DESIGN	All Rounded
DIMENSIONS (mm)	754.5 x 735 x 1732 (W x D x H)
NET WEIGHT (kg)	90
COOLING SYSTEM	Fan Cooling
TEMPERATURE CONTROL	Knob Dial
DEFROSTING SYSTEM	Full Automatic Heater Defrost With a Timer
DOOR FINISH	Vinyl Coated Metal
HANDLE TYPE	Bar
INNER CASE	ABS Resin
INSULATION	Polyurethane Foam

ITEMS	SPECIFICATIONS	
VEGETABLE TRAY	Transparent Drawer Type	
COMPRESSOR	PTC Starting Type	
EVAPORATOR	Fin Tube Type	
CONDENSER	Wire Condenser	
REFRIGERANT	R-134a (155 g)	
LUBRICATING OIL	ISO10 (280 cc)	
DEFROSTING DEVICE	SHEATH HEATER	
LAMP	FREEZER	25 W
	REFRIGERATOR	40 W

## 2. Ref. No.: LRTBC2025T

ITEMS	SPECIFICATIONS
DOOR DESIGN	All Rounded
DIMENSIONS (mm)	754.5 x 788 x 1732 (W x D x H)
NET WEIGHT (kg)	93
COOLING SYSTEM	Fan Cooling
TEMPERATURE CONTROL	Knob Dial
DEFROSTING SYSTEM	Full Automatic Heater Defrost With a Timer
DOOR FINISH	Vinyl Coated Metal
HANDLE TYPE	Bar
INNER CASE	ABS Resin
INSULATION	Polyurethane Foam

ITEMS	SPECIFICATIONS	
VEGETABLE TRAY	Transparent Drawer Type	
COMPRESSOR	PTC Starting Type	
EVAPORATOR	Fin Tube Type	
CONDENSER	Wire Condenser	
REFRIGERANT	R-134a (155 g)	
LUBRICATING OIL	ISO10 (280 cc)	
DEFROSTING DEVICE	SHEATH HEATER	
LAMP	FREEZER	25 W
	REFRIGERATOR	40 W

# 2. PARTS IDENTIFICATION

## FREEZER COMPARTMENT

Freezer Shelf

Automatic Ice Maker

Ice Cube Box

Freezer Temperature Control Dial

## REFRIGERATOR COMPARTMENT

Temperature Control Dial

Lamp

Shelves

Egg Box (option)

Snack Corner

Crisper

Used to keep fruits and vegetables fresh and crisp.

Base Grille

1. Bend @ down.
2. Push the grille toward the refrigerator.
3. (b) <Three protecting parts> should be beneath the bottom plate while pushing the grille.

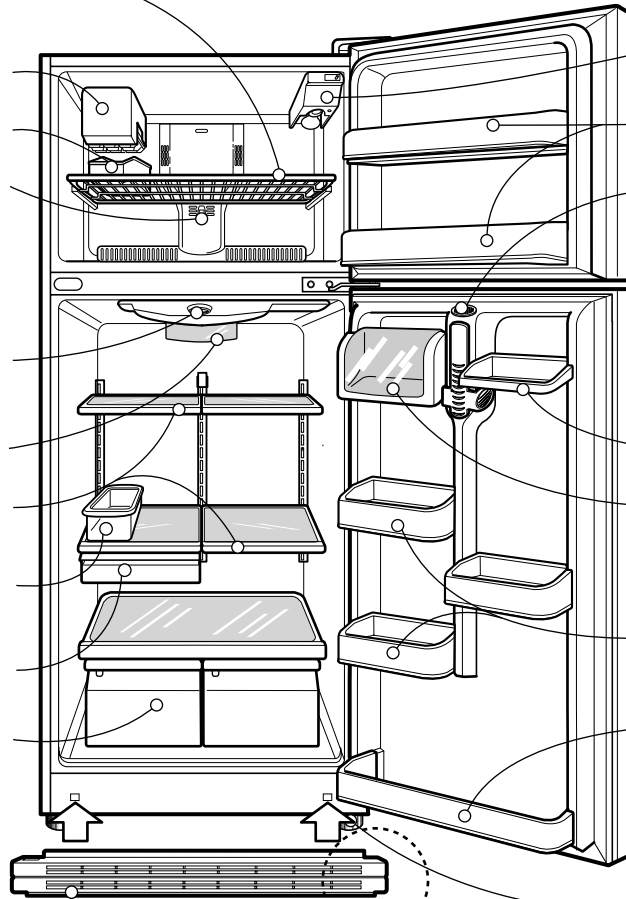

Lamp

Freezer Door Bin

**Door Cooling**  
On the refrigerator door, the cold air passageway is installed to supply cold air to the doorside of the refrigerator compartment.

Can Server

Dairy Corner

Adjustable Door Bin

Refrigerator Door Rack

Leveling Screw (Inside)

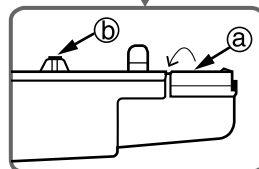

# 3. DISASSEMBLY

## 3-1 DOOR

### ● Freezer Door

1. Remove the hinge cover by pulling it upwards.
2. Loosen hexagonal bolts fixing the upper hinge to the body and lift the freezer door.

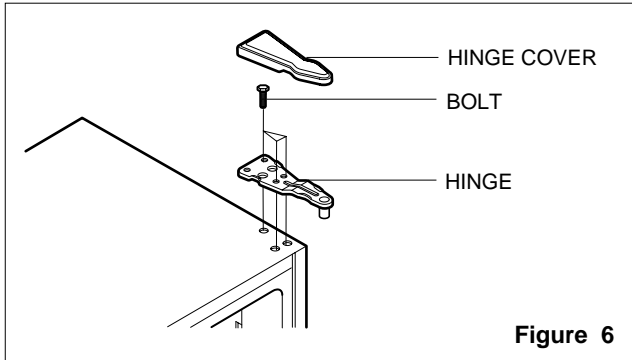

3. Pull out the door gasket to remove from the door foam assembly.

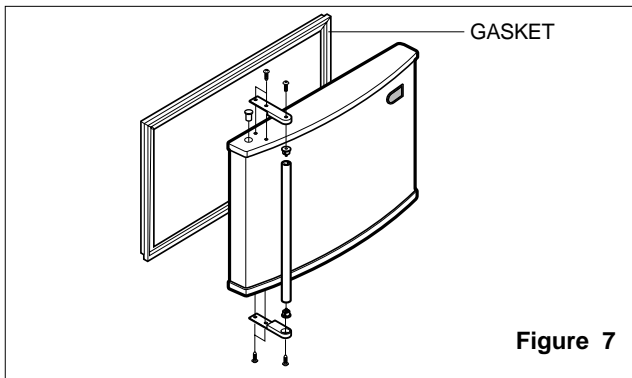

### ● Refrigerator Door

1. Loosen hexagonal bolts attaching the lower hinge to the body to remove the refrigerator door only.

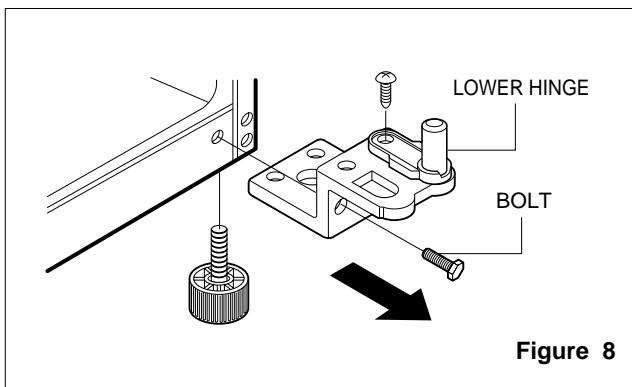

2. Pull out the door gasket to remove from the door foam assembly.

## 3-2 DOOR SWITCH

1. To remove the door switch, pull out it with a slotted type driver as shown in (figure 9).
2. Disconnect the lead wire from the switch.

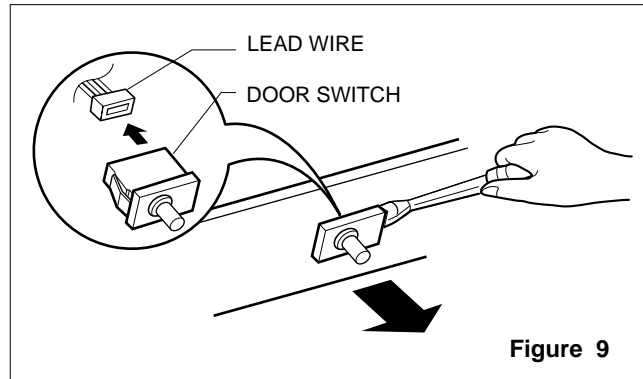

## 3-3 THERMOSTAT

1. Remove Control Box-R by loosening 2 screws attached to ceiling of Refrigerator compartment (Figure 10)
2. Separate the thermostat and dial knob F.
3. Remove the thermostat by disconnecting the lead wire.

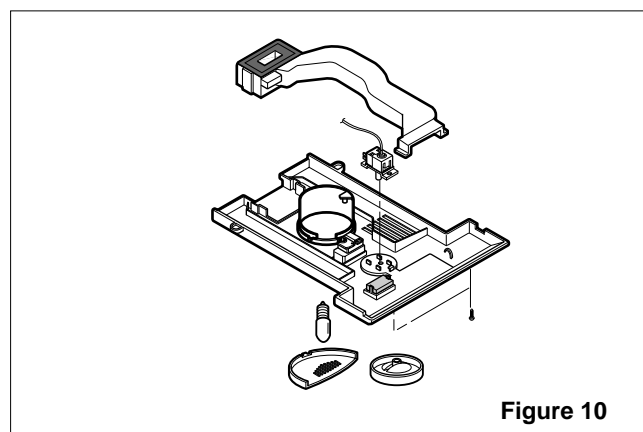

### 3-4 FAN AND FAN MOTOR

1. Remove the freezer shelf. (If your refrigerator have an Ice Maker, disassemble the Ice maker first)
2. Remove the grille by pulling it out and by loosening a screw.
3. Remove the Fan Motor assembly by loosening 4 screws and disassemble the shroud.
4. Pull out the fan and separate the Fan Motor and Bracket.

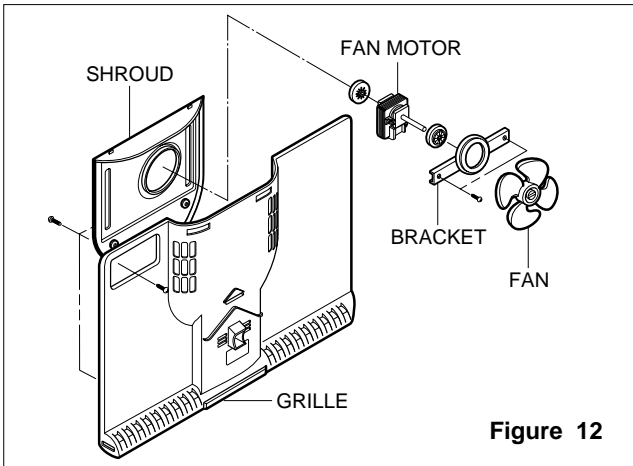

Figure 12

### 3-5 DEFROST CONTROL ASSEMBLY

Defrost control assembly consists of Defrost Thermostat and FUSE-M.

Defrost Thermostat functions to defrost automatically and it is attached to metal side of the Evaporator and senses Temp.

Fuse-M is a safety device for preventing over-heating of the Heater when defrosting.

At the temperature of 77°C, it stops the emission of heat from the Heater.

1. Pull out the grille assembly.
2. Separate the connector connected with the Defrost Control assembly and replace the Defrost Control assembly after cutting the Tie Wrap. (Figure 14)

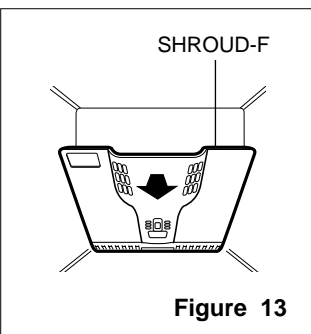

Figure 13

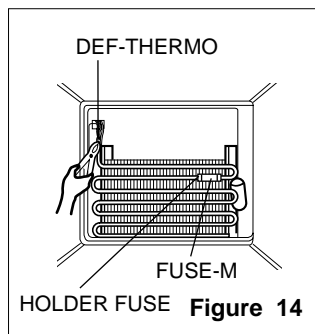

Figure 14

### 3-6 LAMP

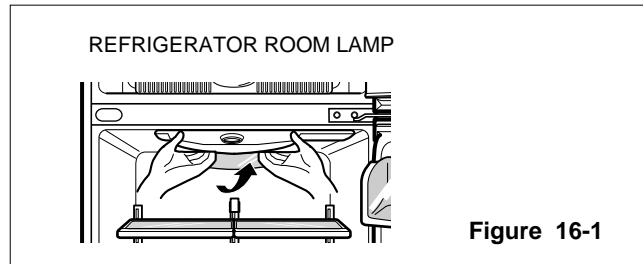

Figure 16-1

#### 3-6-1 Refrigerator room lamp

1. Unplug the power cord from the outlet.
2. Remove refrigerator shelves.
3. Release the hooks on both ends of the lamp shield and pull the shield downward to remove it.
4. Turn the lamp counterclockwise.
5. Assemble in reverse order of disassembly. Replacement bulb must be the same specification as original. (Max 40 W)

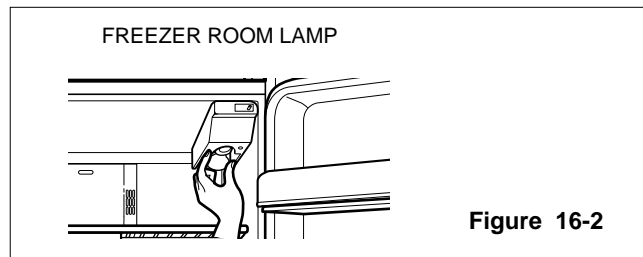

Figure 16-2

#### 3-6-2 Freezer room lamp

1. Unplug refrigerator or disconnect power.
2. Reach behind light shield to remove bulb.
3. Replace bulb with a 25-watt appliance bulb.
4. Plug in refrigerator or reconnect power.

### 3-7 CONTROL BOX-R

1. First, remove all shelves in the refrigerator and Control Box-R by loosening 2 screws.

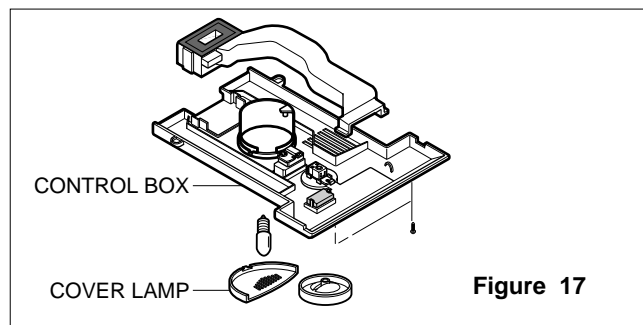

Figure 17

2. Remove the Control Box-R by pulling it downward.
3. Disconnect the lead wire on the right position and separate timer, thermostat, Lamp socket, etc.

# 4. ADJUSTMENT

## 4-1 COMPRESSOR

### 4-1-1 Role

The compressor intakes low temperature and low pressure gas evaporated from evaporator of the refrigerator, and condenses this gas to high temperature and high pressure gas, and then plays delivering role to condenser.

### 4-1-2 Composition

The compressor includes overload protection. The PTC starter and OLP (overload protector) are outside the compressor. Since the compressor is manufactured to tolerances of 1 micron, and is sealed in a dust - and moisture - free environment, use extreme caution when repairing it.

### 4-1-3 Note for Usage

- (1) Be careful not to allow over-voltage and over-current.
- (2) No Strike  
If applying forcible power or strike (dropping or careless handling), poor operation and noise may occur.
- (3) Use proper electric components appropriate to the Compressor.
- (4) Note to Keep Compressor.  
If Compressor gets wet in the rain and rust in the pin of Hermetic Terminal, the result may be poor operation and poor contact may cause.
- (5) Be careful that dust, humidity, and welding flux don't contaminate the compressor inside when replacing the Compressor. Dust, humidity, and flux due to welding which contaminates the cylinder may cause lockage and noise.

## 4-2 PTC-STARTER

### 4-2-1 Composition of PTC-Starter

- (1) PTC (Positive Temperature Coefficient) is a no-contact semiconductor starting device which uses ceramic material consisting of BaTiO<sub>3</sub>.
- (2) The higher the temperature is, the higher the resistance value. These features are used as starting device for the Motor.

### 4-2-2 Role of PTC-Starter

- (1) PTC is attached to Hermetic Compressor used for Refrigerator, Show Case, and starting Motor.
- (2) Compressor for household refrigerator applies to single-phase induction Motor.  
For normal operation of the single-phase induction motor, in the starting operation flows in both main coil and sub-coil. After the starting is over, the current in subcoil is cut off. The proper features of PTC play all the above roles. So, PTC is used as a motor starting device.

## 4-2-3 PTC-Applied Circuit Diagram

### ● According to Starting Method for the Motor

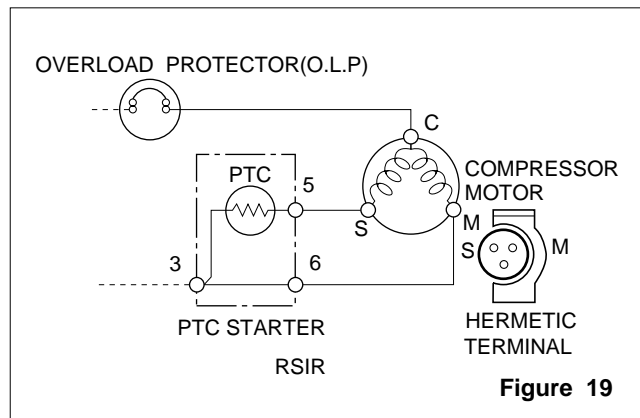

## 4-2-4 Motor Restarting and PTC Cooling

- (1) For restarting after power off during normal Compressor Motor operation, plug the power cord after 5 min. for pressure balance of Refrigerating Cycle and PTC cooling.
- (2) During normal operation of the Compressor Motor, PTC elements generate heat continuously. Therefore, if PTC isn't cooled for a while after the power has been shut off, the motor will not restart.

## 4-2-5 Relation of PTC-Starter and OLP

- (1) If the power is off during operation of Compressor and the power is on before the PTC is cooled, (instant shut-off within 2 min. or unplugging and reconnecting), the PTC isn't cooled and a resistance value grows. As a result, current can't flow to the sub-coil, the Motor can't operate, and the OLP operates by flowing over current in only in the main-coil.
- (2) While the OLP repeats on and off operation about 3-5 times, PTC is cooled and Compressor Motor performs normal operation.  
If OLP doesn't operate when PTC is not cooled, Compressor Motor is worn away and causes circuit-short and fire. Therefore, always use a properly attached OLP.

## 4-2-6 Note to Use PTC-Starter

- (1) Be careful not to allow over-voltage and over-current.
- (2) Do not strike  
Don't apply a forcible power or strike.
- (3) Keep apart from any liquid.  
If liquid, such as oil or water away enters the PTC, PTC materials may fail due to insulation breakdown of the material itself.
- (4) Don't change PTC at your convenience.  
Don't disassemble PTC and case. If the exterior to the PTC-starter is damaged, resistance value is altered and it may cause poor starting of the compressor motor may cause.
- (5) Use a properly attached PTC.



### 4-3 OLP (OVERLOAD PROTECTOR)

#### 4-3-1 Definition of OLP

- (1) OLP (OVERLOAD PROTECTOR) is attached to the Compressor and protects the Motor by cutting the current to the Motor if the temperature rises and activates the bimetal spring in the OLP.
- (2) When over-voltage flows to Compressor motor, the Bimetal works by heating the heater inside the OLP, and the OLP protects Motor by cutting off current which flows to the Compressor Motor.

#### 4-3-2 Role of the OLP

- (1) The OLP is attached to the Hermetic Compressor used for the Refrigerator and prevents the Motor Coil from being started in the Compressor.
- (2) Do not turn the Adjust Screw of the OLP in any way for normal operation of the OLP.  
(Composition and connection diagram of OLP)

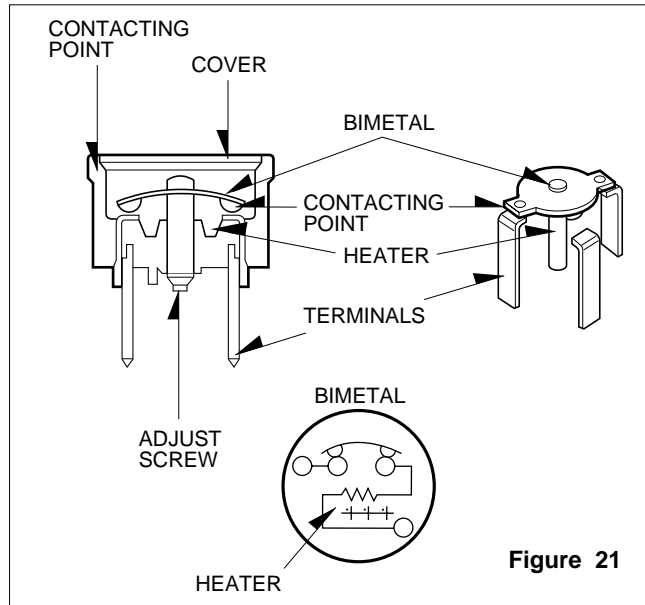
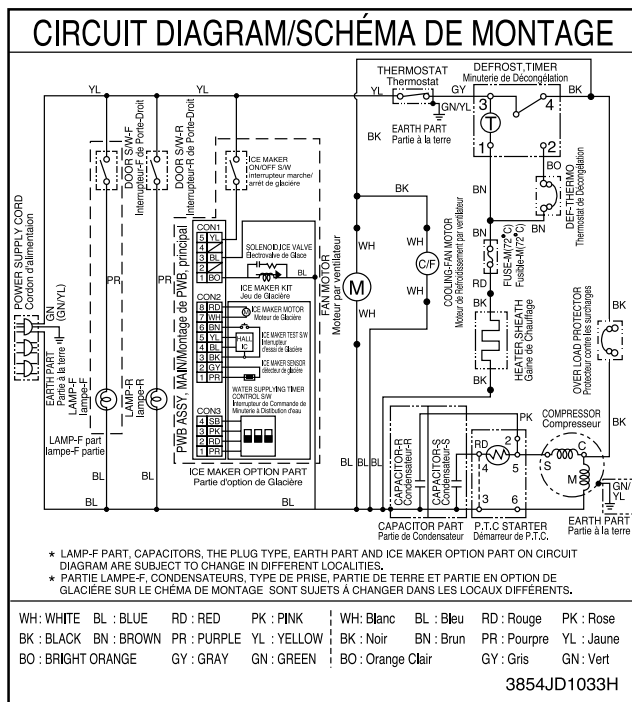

Figure 21

## 5. CIRCUIT DIAGRAM

Ref. No.: LRTBC1825T



Ref. No.: LRTBC2025T

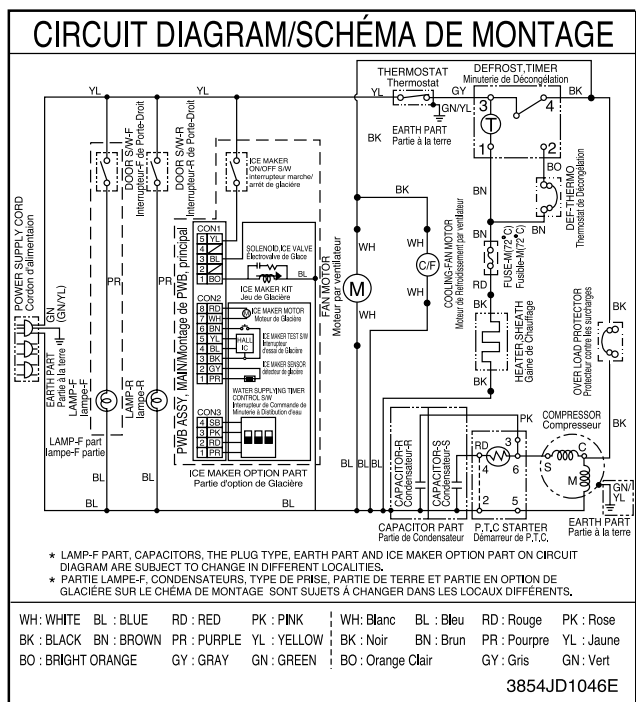

# 6. TROUBLESHOOTING

## 6-1 COMPRESSOR AND ELECTRIC COMPONENTS

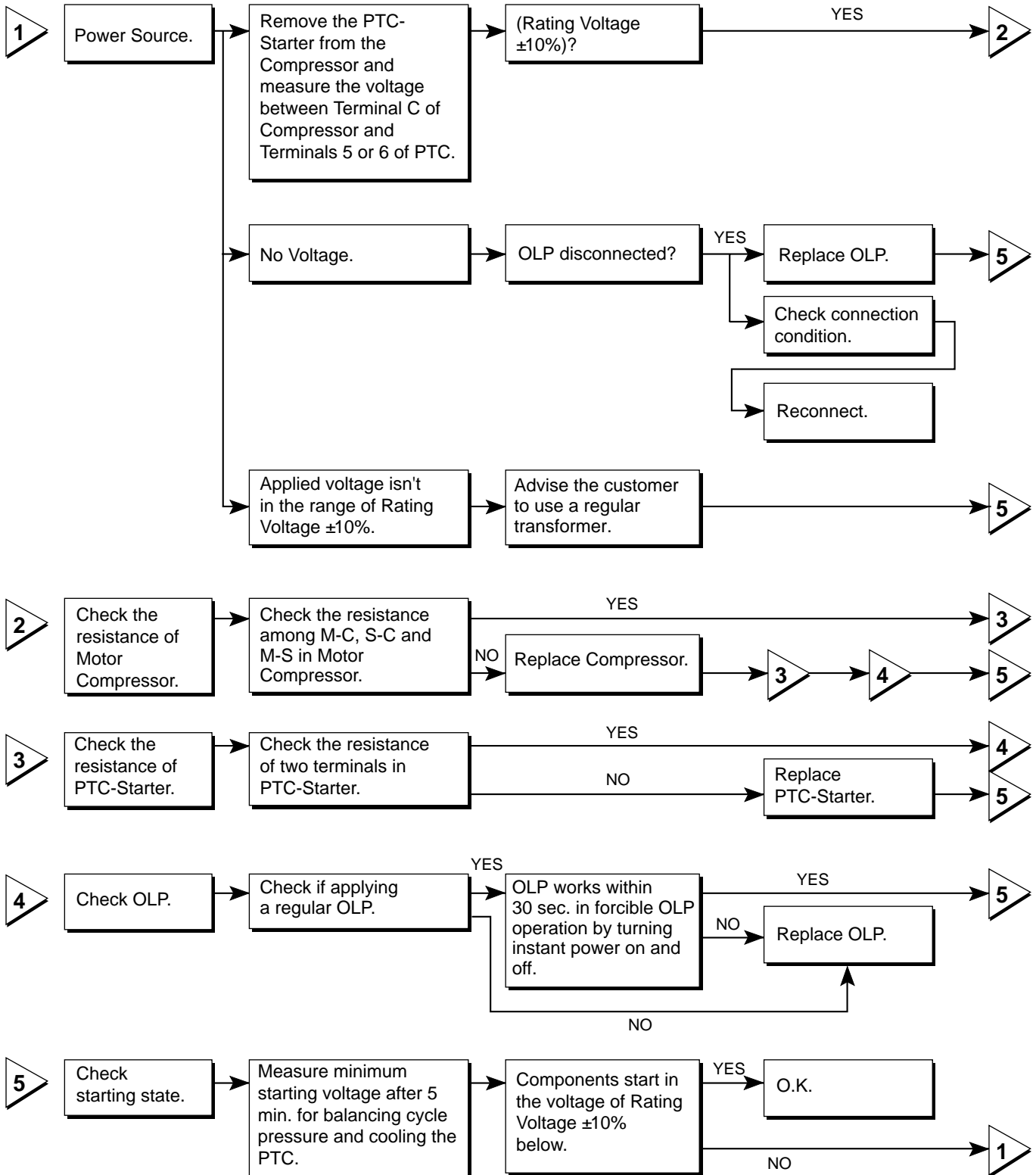

## 6-2 PTC AND OLP

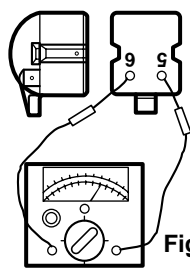
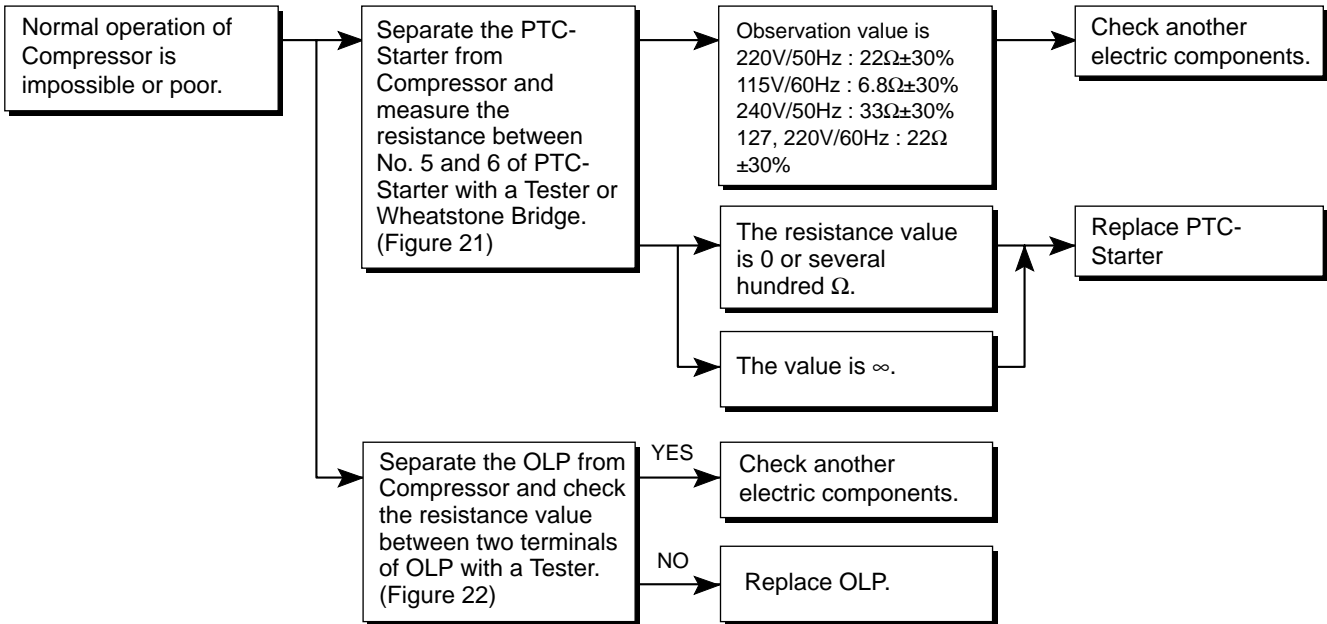

Figure 21

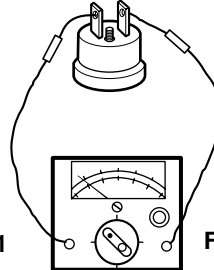

Figure 22

## 6-3 DEFROST TIMER

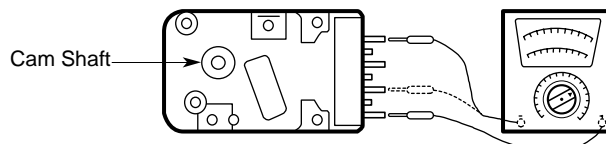
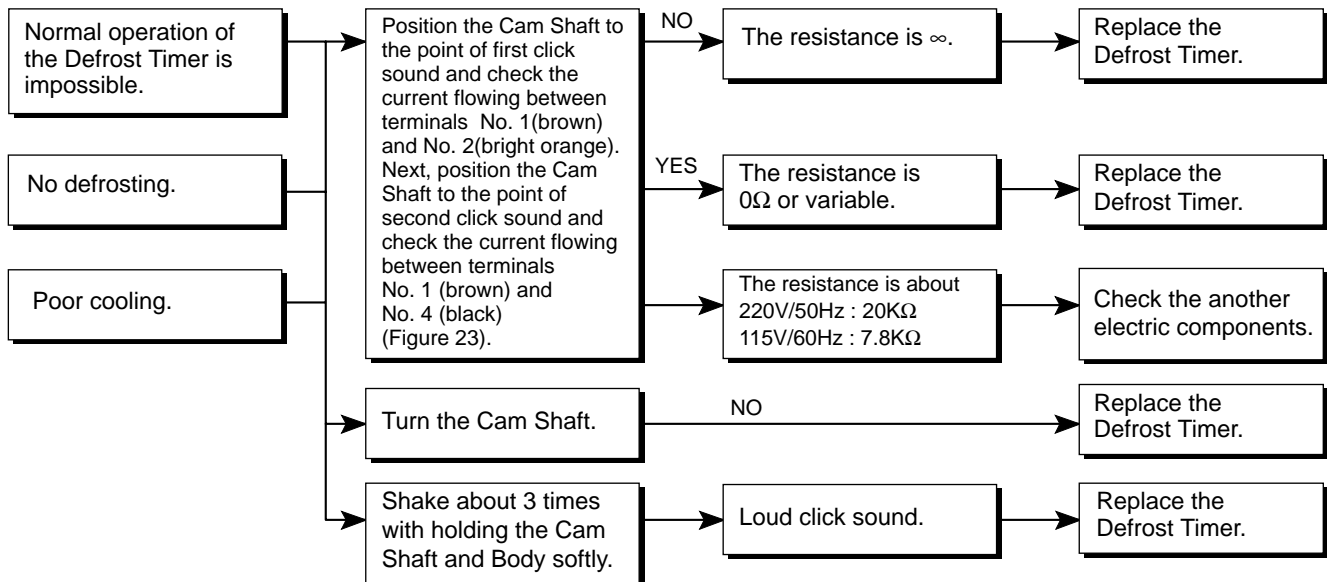
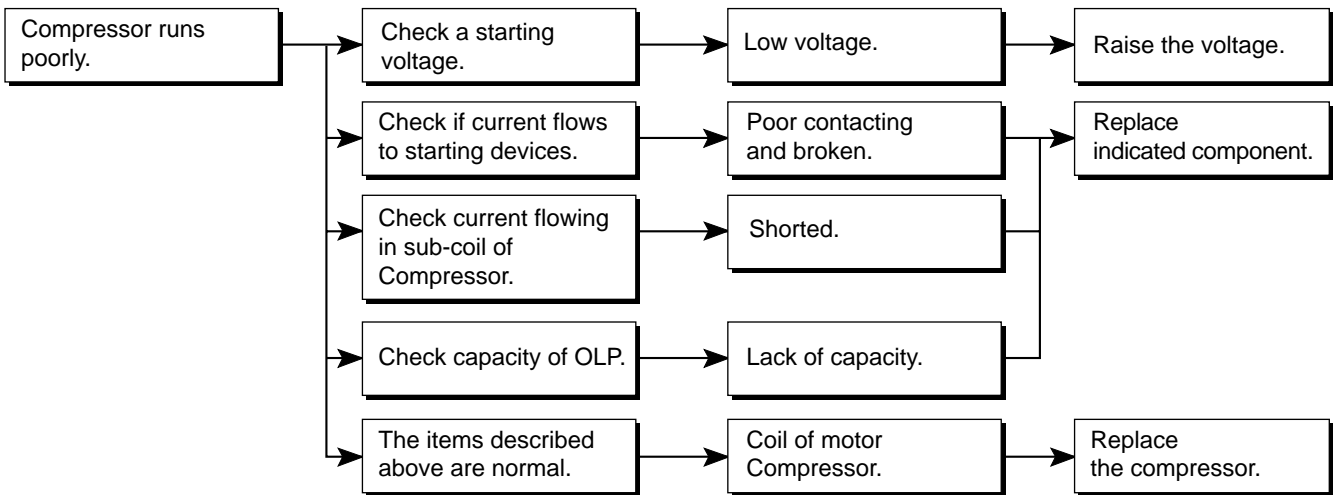
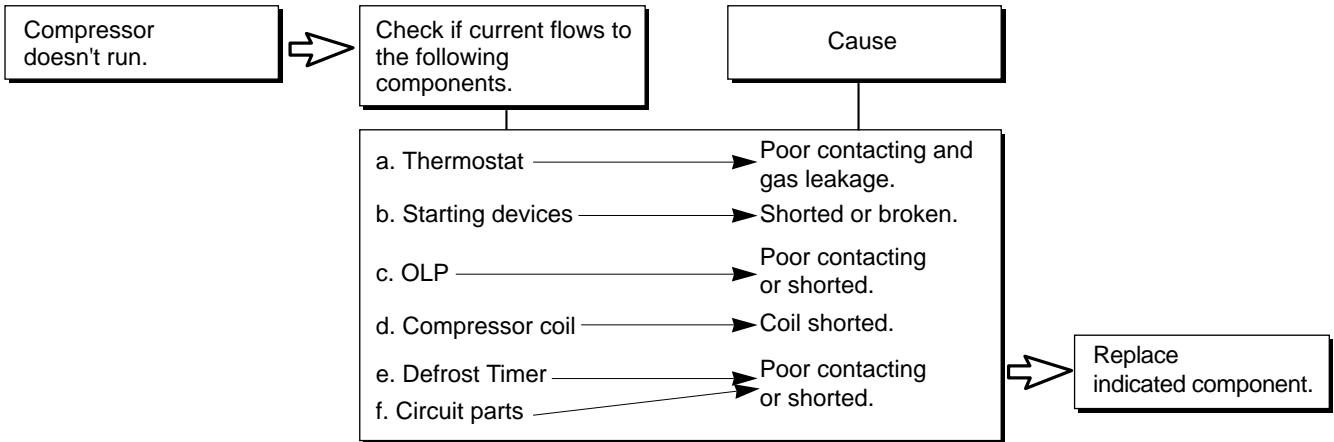

Figure 23

## 6-4 OTHER ELECTRIC COMPONENTS

### ▼ Cooling is impossible



### ▼ Cooling ability is poor

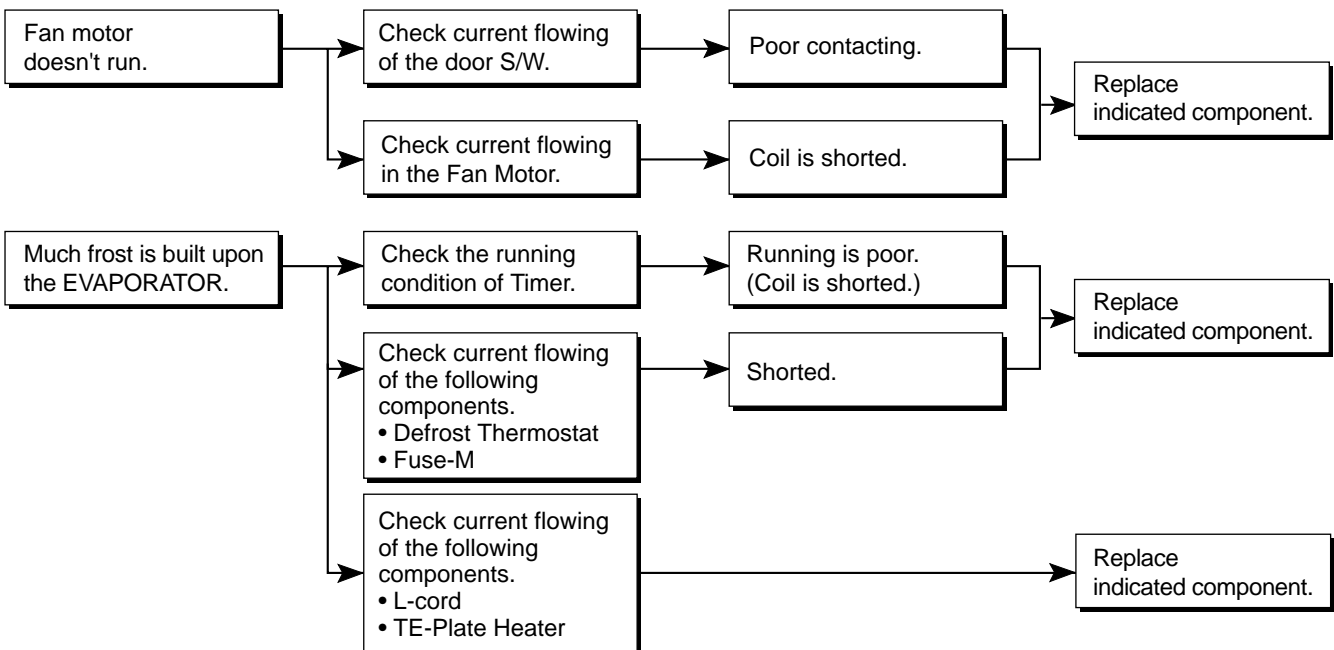

## 6-4 SERVICE DIAGNOSIS CHART

COMPLAINT	POINTS TO BE CHECKED	REMEDY
Cooling is impossible.	<ul style="list-style-type: none"> <li>Is the power cord unplugged from the outlet?</li> <li>Check if the power S/W is set to OFF.</li> <li>Check if the fuse of power S/W is shorted.</li> <li>Measure the voltage of power outlet.</li> </ul>	<ul style="list-style-type: none"> <li>Plug to the outlet.</li> <li>Set the switch to ON.</li> <li>Replace fuse.</li> <li>If voltage is low, correct wiring.</li> </ul>
Cooling ability is poor.	<ul style="list-style-type: none"> <li>Check if the set is placed close to wall.</li> <li>Check if the set is placed close to stove, gas cooker and direct rays.</li> <li>Is the ambient temperature high or the room door closed?</li> <li>Check if put in is hot.</li> <li>Did you open the door of the set too often or check if the door is closed up?</li> <li>Check if the Control is set to WARM.</li> </ul>	<ul style="list-style-type: none"> <li>Place the set with the space of about 10 cm (4 inches).</li> <li>Place the set apart from these heat appliances.</li> <li>Make the ambient temperature below.</li> <li>Put in foods after cooled down.</li> <li>Don't open the door too often and close it firmly.</li> <li>Set the control to mid-position.</li> </ul>
Foods in the Refrigerator are frozen.	<ul style="list-style-type: none"> <li>Is food placed in cooling air outlet?</li> <li>Check if the Dial is set to COLD.</li> <li>Is the ambient temperature below 5°C?</li> </ul>	<ul style="list-style-type: none"> <li>Place foods in high temperature section. (Front Part)</li> <li>Set the dial to MID.</li> <li>Set the dial to WARM.</li> </ul>
Dew or ice forms inside the set.	<ul style="list-style-type: none"> <li>Is liquid food stored?</li> <li>Check if put in hot.</li> <li>Did you open the door of the set too often or check if the door is closed.</li> </ul>	<ul style="list-style-type: none"> <li>Seal up liquid foods with wrap.</li> <li>Put in foods after cooled down.</li> <li>Don't open the door too often and close it firmly.</li> </ul>
Dew forms in the Exterior Case.	<ul style="list-style-type: none"> <li>Check if ambient temperature and humidity of surrounding air are high.</li> <li>Is there gap in the door gasket?</li> </ul>	<ul style="list-style-type: none"> <li>Wipe dew with a dry cloth. This occurrence is solved naturally in low temperature and humidity.</li> <li>Fill up the gap.</li> </ul>
Abnormal noise.	<ul style="list-style-type: none"> <li>Is the set positioned in a firm and even place?</li> <li>Are any unnecessary objects set in the back side of the set?</li> <li>Check if the Drip Tray is not firmly fixed.</li> <li>Check if the cover of mechanical room in below and front side is taken out.</li> </ul>	<ul style="list-style-type: none"> <li>Adjust the Adjust Screw, and position in the firm place.</li> <li>Remove the objects.</li> <li>Fix it firmly on the original position.</li> <li>Place the cover at the original position.</li> </ul>
Door does not close well.	<ul style="list-style-type: none"> <li>Check if the door packing is dirty with filth such as juice.</li> <li>Is the set positioned in a firm and even place?</li> <li>Is too much food putted in the set?</li> </ul>	<ul style="list-style-type: none"> <li>Clean the door packing.</li> <li>Position in the firm place and level the Adjust Screw.</li> <li>Keep foods not to reach the door.</li> </ul>
Ice and foods smell unpleasant.	<ul style="list-style-type: none"> <li>Check if the inside of the set is dirty.</li> <li>Did you keep fragrant foods without wrapping?</li> <li>It smells of plastic.</li> </ul>	<ul style="list-style-type: none"> <li>Clean the inside of the set.</li> <li>Wrap fragrant foods.</li> <li>The new products smells of plastic, but it will go away after 1-2 weeks.</li> </ul>

● In addition to the items described left, refer to the followings to solve the complaint.

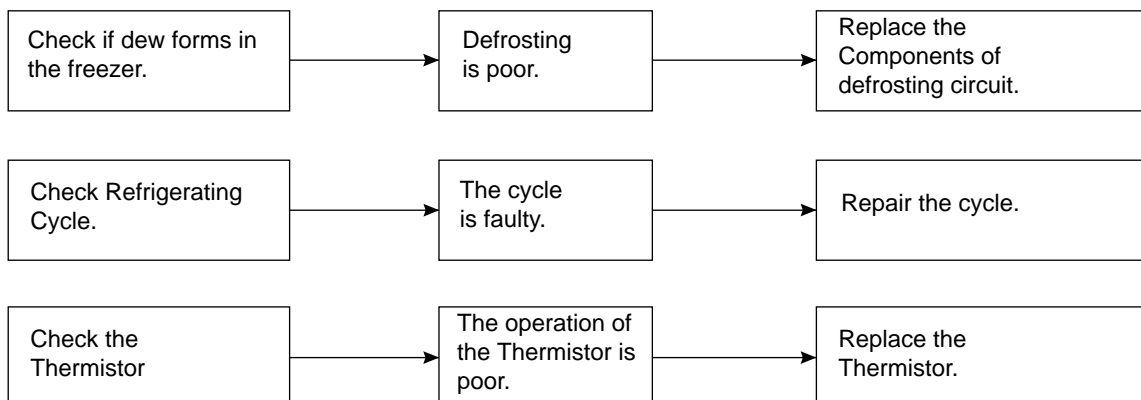

## 6-5 REFRIGERATING CYCLE

### ▼ Troubleshooting Chart

CAUSE		STATE OF THE SET	STATE OF THE EVAPORATOR	TEMPERATURE OF THE COMPRESSOR	REMARKS
LEAKAGE	PARTIAL LEAKAGE	Freezer compartment and Refrigerator don't cool normally.	Low flowing sound of Refrigerant is heard and frost forms in inlet only	A little higher than ambient temperature.	<ul style="list-style-type: none"> <li>Refrigerant level is low due to a leak.</li> <li>Normal cooling is possible when injecting of Refrigerant the regular amount.</li> </ul>
	WHOLE LEAKAGE	Freezer compartment and Refrigerator don't cool normally.	Flowing sound of refrigerant is not heard and frost isn't formed.	Equal to ambient temperature.	<ul style="list-style-type: none"> <li>No discharging of Refrigerant.</li> <li>Normal cooling is possible when injecting of Refrigerant the regular amount.</li> </ul>
CLOGGED BY DUST	PARTIAL CLOG	Freeze compartment and Refrigerator don't cool normally.	Flowing sound of refrigerant is heard and frost forms in inlet only.	A little higher than ambient temperature.	<ul style="list-style-type: none"> <li>Normal discharging of refrigerant.</li> <li>The capillary tube is faulty.</li> </ul>
	WHOLE CLOG	Freezer compartment and Refrigerator don't cool.	Flowing sound of refrigerant is not heard and frost isn't formed.	Equal to ambient temperature.	<ul style="list-style-type: none"> <li>Normal discharging of Refrigerant.</li> </ul>
MOISTURE CLOG		Cooling operation stops periodically.	Flowing sound of refrigerant is not heard and frost melts.	Lower than ambient temperature	<ul style="list-style-type: none"> <li>Cooling operation restarts when heating the inlet of capillary tube.</li> </ul>
DEFECTIVE COMPRESSION	COMP-RESSION	Freezer and Refrigerator don't cool.	Low flowing sound of refrigerant is heard and frost forms in inlet only.	A little higher ambient temperature.	<ul style="list-style-type: none"> <li>Low pressure at high side of compressor due to low refrigerant level.</li> </ul>
	NO COMP-RESSION	No compressing operation.	Flowing sound of refrigerant is not heard and no frost.	Equal to ambient temperature.	<ul style="list-style-type: none"> <li>No pressure of high pressure part in the compressor.</li> </ul>

### ▼ Leakage Detection

- Observe discharging point of refrigerant which may be in the oil discharging part in the compressor and hole of evaporator.

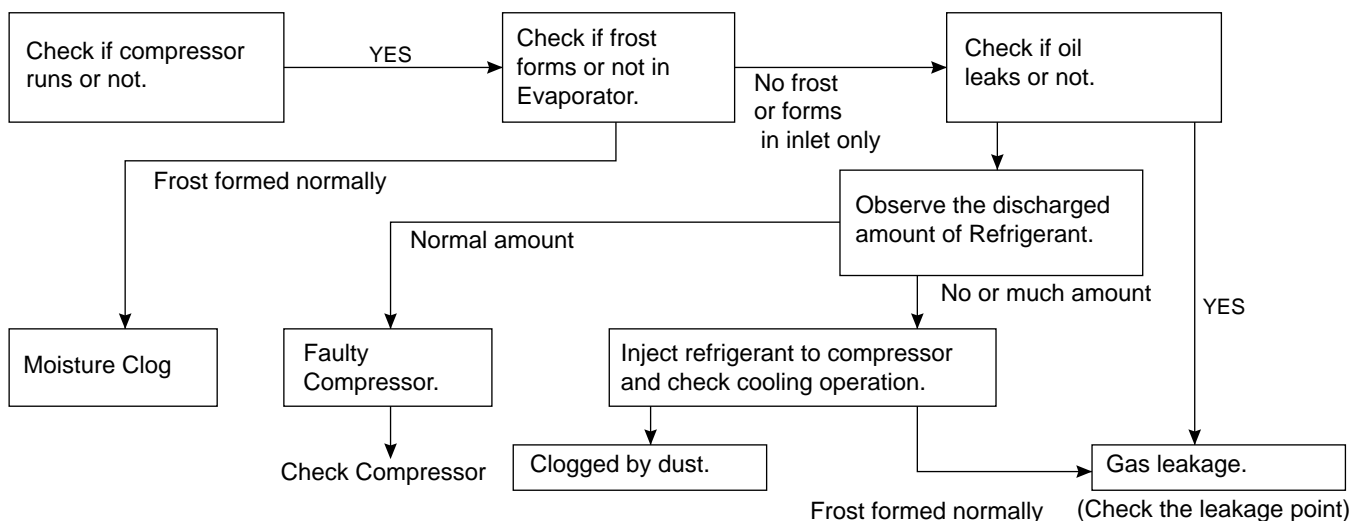

▼ General Control of Refrigerating Cycle

NO.	ITEMS	UNIT	STANDARDS	PURPOSES	REMARKS	
1	Pipe and piping system opening time	Min.	Pipe: within 1 hour. Comp: within 10 minutes. Drier: within 20 minutes.	To protect moisture penetration.	The opening time should be reduced to a half of the standards during rain and rainy seasons (the penetration of water into the pipe is dangerous).	
2	Welding	Nitrogen pressure	Weld under Nitrogen atmosphere. (N <sub>2</sub> pressure: 0.1~0.2 kg/cm <sup>2</sup> )	To protect oxide scale formation.	- Refer to repair note in each part. - R-134a refrigerant is more susceptible to leaks than R-12 and requires more care during welding. - Do not apply force to pipes before and after welding to protect pipe from cracking.	
3	N <sub>2</sub> sealed parts	Confirm N <sub>2</sub> leak	Confirm air leaking sounds when removing cap. Sound: usable No sound: not usable	To protect moisture penetration.	- In case of evaporator parts, if it doesn't make sound when removing cap, blow dry air or N <sub>2</sub> gas for more than 1 min and use the parts.	
4	Refrigeration Cycle	Evacuation time	Min.	More than 40 minutes	To remove moisture.	
		Vacuum degree	Torr	Below 0.03 (ref)		Note: Only applicable to the model equipped with reverse flow protect plate.
		Vacuum	EA	High and low pressure sides are evacuated at the same time for models above 200 l.		Vacuum efficiency can be improved by operating compressor during evacuation.
		Vacuum piping	EA	Use R-134a exclusive manifold.	To protect mixing of mineral and ester oils.	The bushing pipes for R-12 refrigerant shall be melted when they are used for R-134a refrigerant (causes of leak.)
		Pipe coupler	EA	Use R-134a exclusive.	To protect R-12 refrigerant mixing.	
		Outlet (Socket)		R-134a exclusive.	"	
	Plug		R-134a exclusive.	"		
5	Refrigerant weighing	EA	Use R-134a exclusively. Weighing allowance: ±5g Note: Winter: -5g Summer: +5g	Do not mix with R-12 refrigerant.	- Do not weigh the refrigerant at too hot or too cold an area. (77°F[25°C] is adequate.) - Make Copper bombe (Device filling refrigerant) Socket: 2SV Plug: 2PV R-134a Note: Do not burn O-ring (bushing) during welding.	
6	Drier replacement		- Use R-134a exclusively for R-134a refrigerator. - Use R-12 exclusively for R-12 refrigerator. - Replace drier whenever repairing refrigerator cycle piping.	To remove the moisture from pipe inside.		
7	Leak check		- Do not use soapy water for check. It may be sucked into the pipe by vacuum.	Defect refrigerant leak area.	- Check oil leak at refrigerant leak area. Use electronic leak detector if oil leak is not found. - The electronic leak detector is very sensitive to halogen gas in the air. It also can detect R-141b in urethane. Practice many times before using this type of detector.	

# 7. OPERATION PRINCIPLE AND REPAIR METHOD OF ICE MAKER

This manual describes function of models adhering Ice Maker.

## 7-1 OPERATION PRINCIPLE

### 7-1-1 Operation principle of Ice Maker

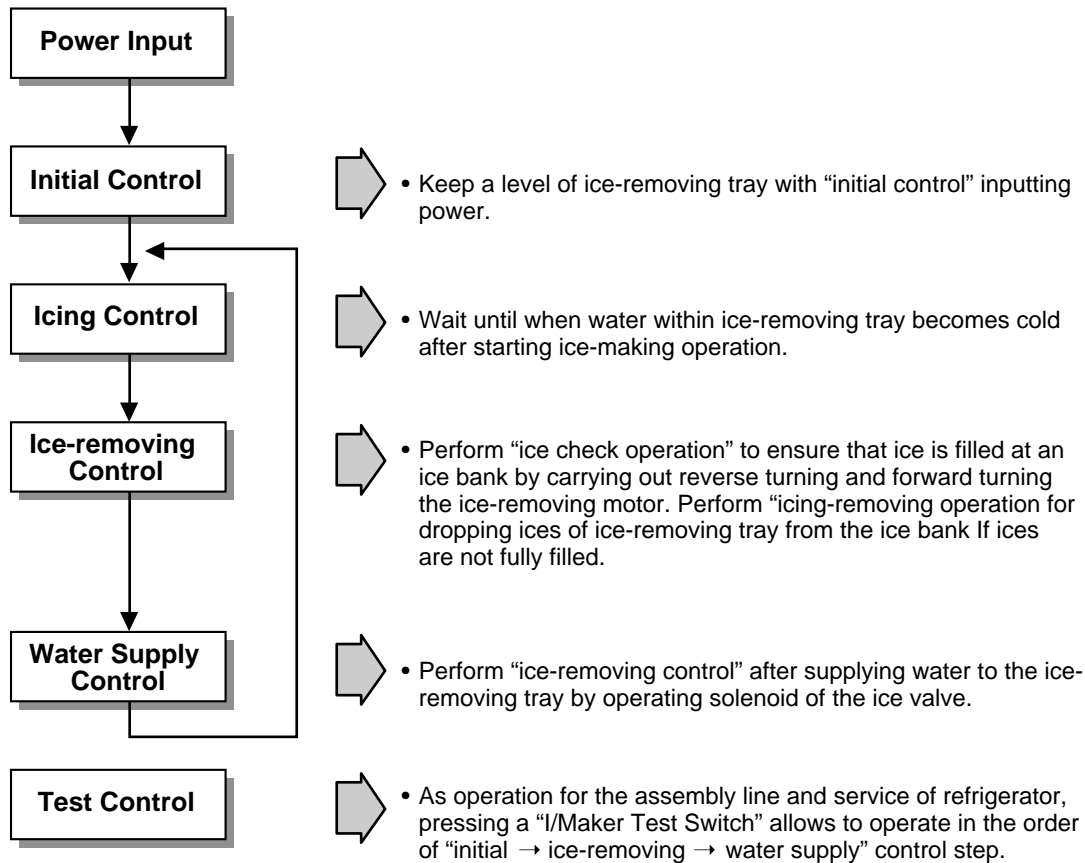

1. Turning the ice-making stop switch off stops ice-making function of the ice-maker and thus no ice is made .
2. Ice-making function stops at the time of selecting ice-making function and release of the ice-making function allows to perform the initial control function again.

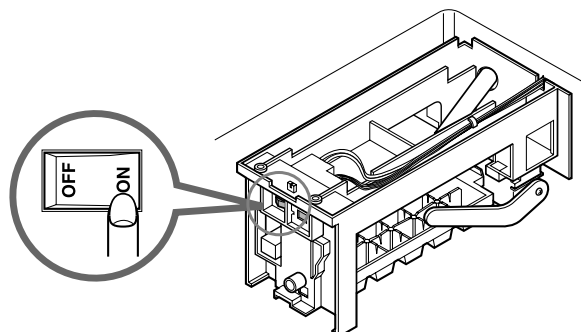

\* Make sure the switch on the ice maker assy is turned "on".





### 7-2-4 Ice-removing control function

1. Ice-removing control means operation to separate ice within ice-making tray ( ice-making container) after ice-making is completed.
2. Step to check ices stored at the ice bank (container for storing ice) are fully filled. It is considered as they are fully filled if signals of the hall sensor are at the On status ("high") before 3.6seconds after rotating positively the ice-making motor. In this case, the ice-making motor remains at the waiting status without performing ice-removing function. Perform ice-detecting operation after rotating positively the ice-making motor in the cycle of an hour if the full ice status is detected. Perform water supply control function after completing ice-removing function in the short of ices stored. Reversely rotating the ice-removing motor in the storage of full ices and then let the motor stop at the position of the ice-making or waiting status.
3. Ice-removing control performs ice-removing operation immediately if ices stored at the ice bank (container for storing ice) are not fully filled (the hall sensor are at the Off status ("low") within 3.6seconds after rotating positively the ice-making motor). In this case, it positively rotates (CW) the ice-removing motor and keeps the ice-making tray at the maximum distortion status and makes ices be separated from the ice-making tray. In this case, ice-detecting lever automatically operates lifting operation with ice-removing operation.
4. Ice-removing control positively rotates (CW) the ice-removing motor and stops it for a second as it considers as maximum distortion point (ice-detecting axle = 160°) if the sensor signal changes from the Off status ("low") to the On status ("high") after 3.6 seconds pass.
5. Ice-removing control positively rotates (CW) the ice-removing motor at the cycle of an hour if problems in ice-making motor or hall sensor are found and performs initial operation or operates initialization of product if normal.
6. Ice-removing control stops for a second at the maximum distortion status of the ice-removing tray (container for storing ice).
7. Step that the ice-removing tray stops for a second and then returns to the level. It returns to the level status returns to the ice-removing tray by reversely rotating the ice-making motor.
8. The cycle of "water supply → ice-making → ice-removing → returning to the level" if becoming the level status.

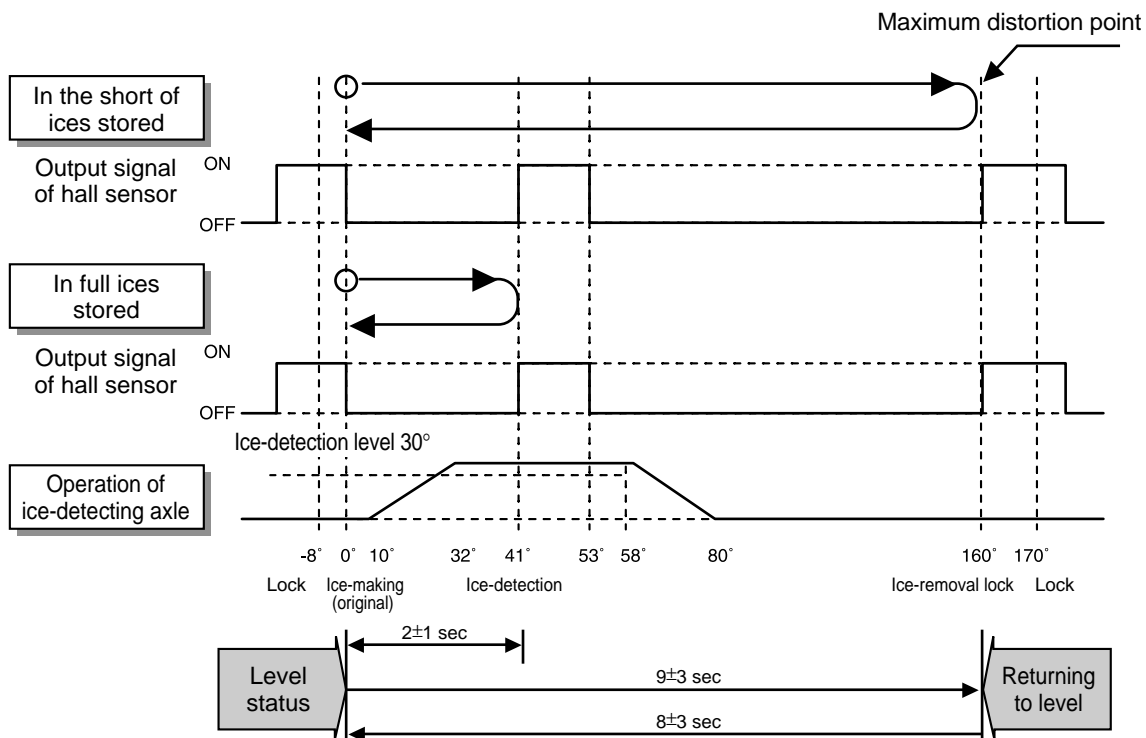

<Timing chart for ice-removal>

---

### 7-2-5 Test Function

1. Function used compulsory operation for the purpose of performing operation test, service and cleaning. This test function is performed if pressing the test switch mounted on the automatic ice-maker itself for 0.5 second or more.
2. The test button operates when the test function is not input but at the level status. It does not perform ice-removal control and water supply control if ices are full during operation of test function
3. Pressing the test button for more than 0.5 seconds at the level the status immediately performs ice-removing operation irrespective of the ice generation conditions of the ice-making tray.  
Caution shall be exercised as water may overflow if operating the test function at the water status that ice-making is not done. A cycle of water supply is performed at the level adjusting operation after ice-removing operation.  
Therefore, the test button allows to check problems in ice-removing operation, level operation and water supply.
4. The test function operates in the normal cycle of ice-making → ice-removal → returning to the level → water supply if water supply is completed.

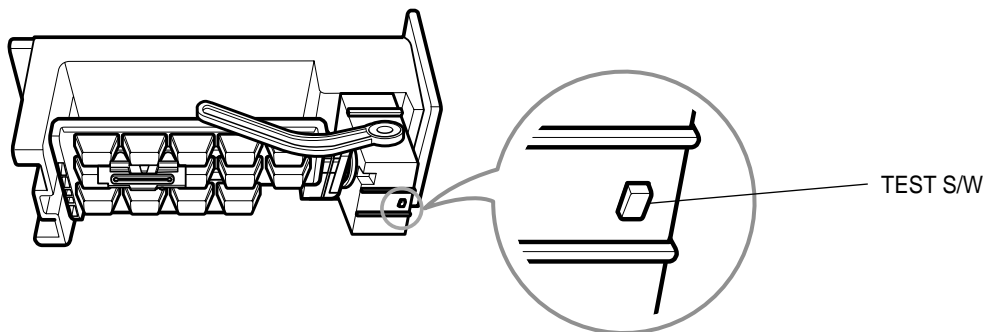

\* To check on the amount of water being supplied, press the Test button. (Hold for 0.5 seconds)

### 7-3 Failure diagnosis method of ice maker

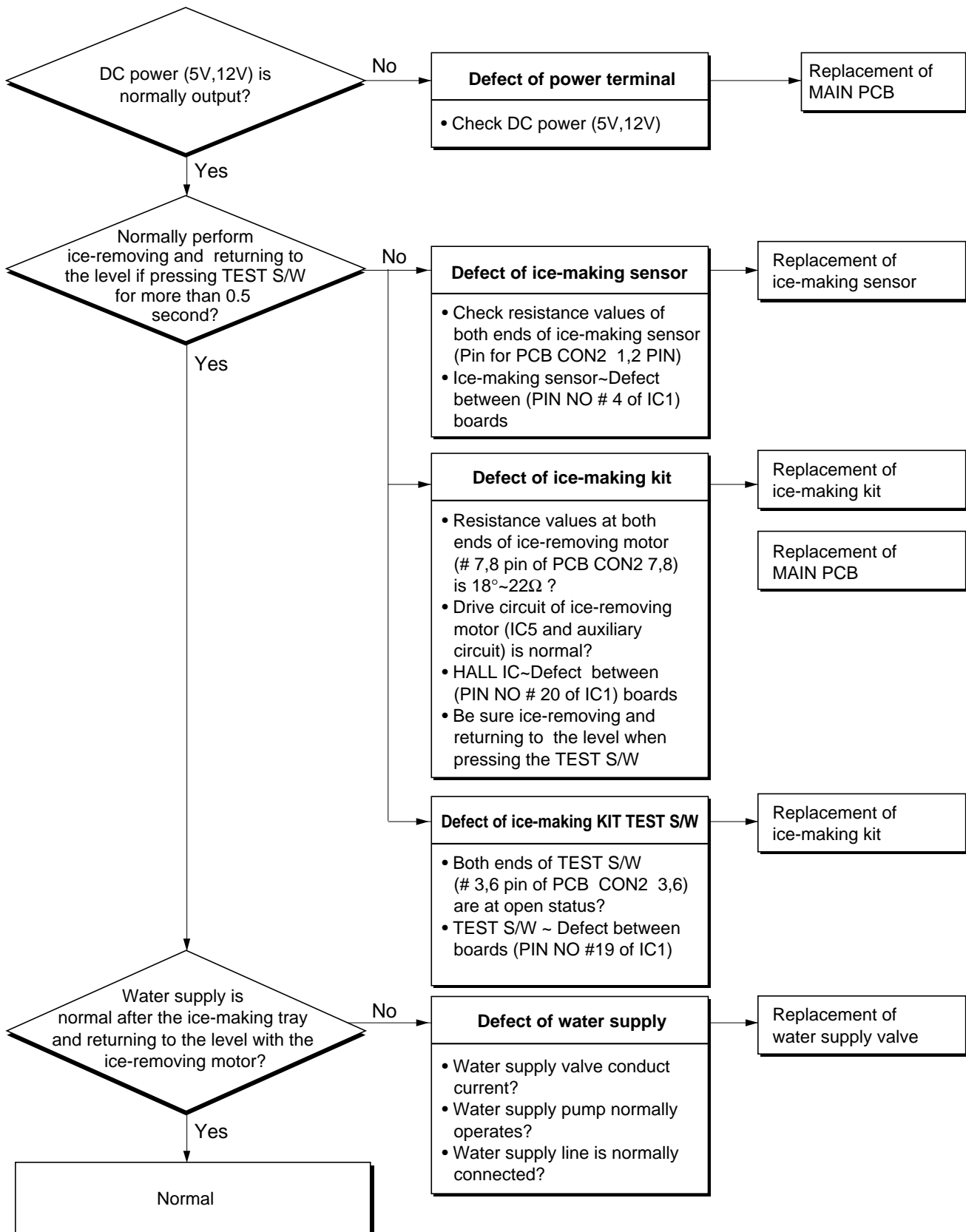

## 7-4 Explanation of ice maker circuits

### 7-4-1 Power circuit

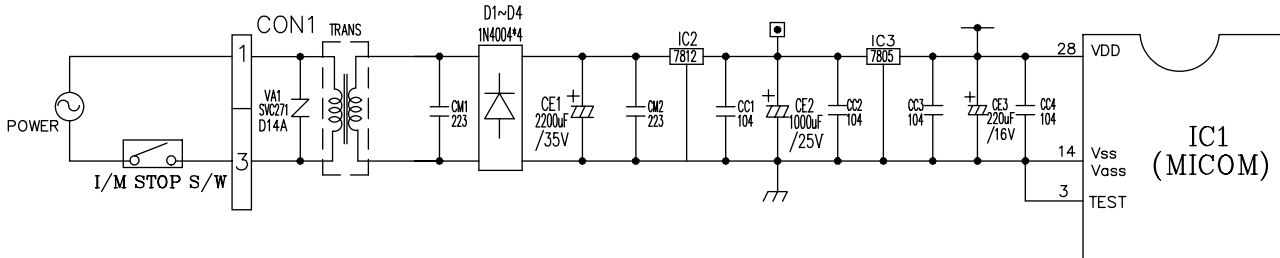

The secondary party of transformer consists of power (12Vdc) for driving display and relay and power (5Vdc) supplying power to MICOM and IC.

In this case, voltage at each part is as follows:

Part	Both ends of VA1	Both ends of CE2	Both ends of CE3
Voltage	115Vac	12Vdc	5Vdc

VA1 is parts for preventing over-voltage and noise and plays a role of protecting elements of the secondary part of transformer as the inside of element becomes short and is broken and power fuse is cut off when power of more than 175V is applied.

### 7-4-2 Vibration circuit

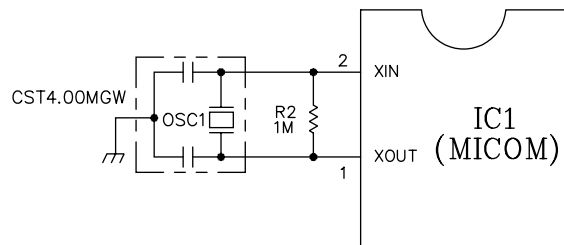

Circuit used for synchronous clock generation for transmitting/receiving information of the inside logic elements of IC and basic time generation for calculating time. Rated parts must be used as counting time is changed at the IC1 or the OSC1 does not operate if SPEC would be changed.

### 7-4-3 Reset circuit

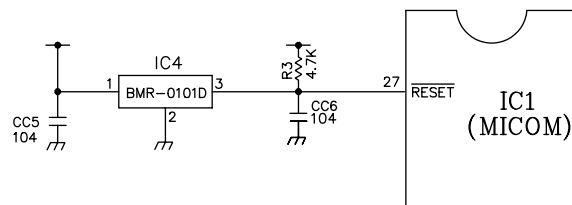

The reset circuit is a circuit that initializes various parts such as RAM, etc inside of the MICOM (IC1) and starts the whole of function from the initial status and 'low' voltage is applied for a constant time (10ms) at the reset terminal of the MICOM at the start of power input.

The reset terminal is at 5V during general operation (the MICOM does not operate in the defect of the reset IC).

## 7-4-4 Load drive circuit

### 1. Load drive status check

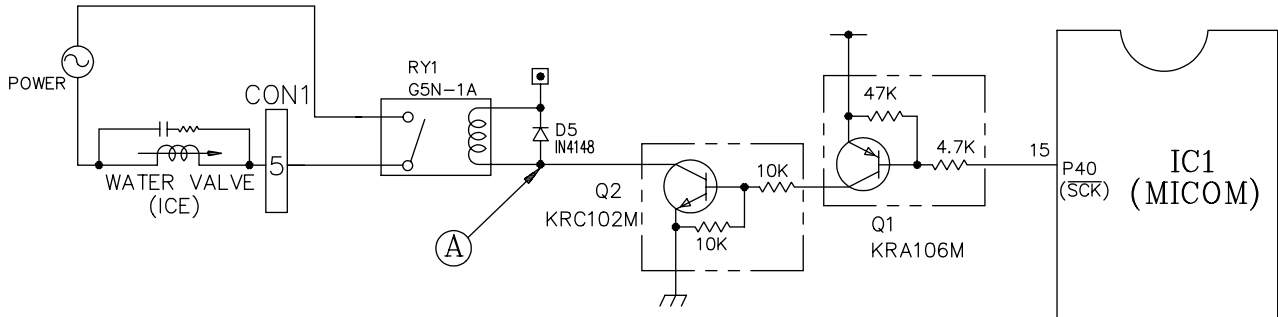

Load Type		Water Valve
Measurement Location		(A)
Condition	ON	1V below
	OFF	12V

### 7-4-5 ICE MAKER drive/circuit

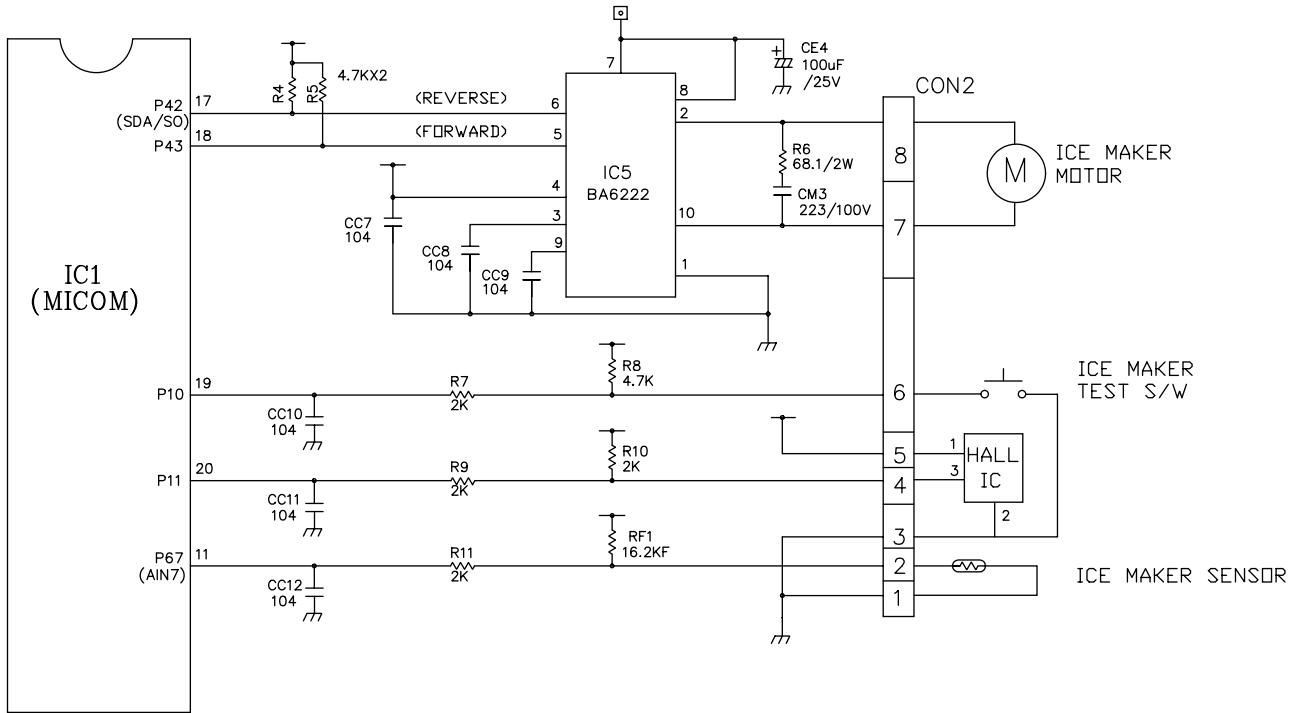

This circuit is a circuit used to embody functions such as ice-removing, full-ice detection, level noise, and ice-making temperature detection of ice-making tray (ice-making container).

## 7-5 Main PWB Assembly and Parts List

### 7-5-1 MAIN PWB

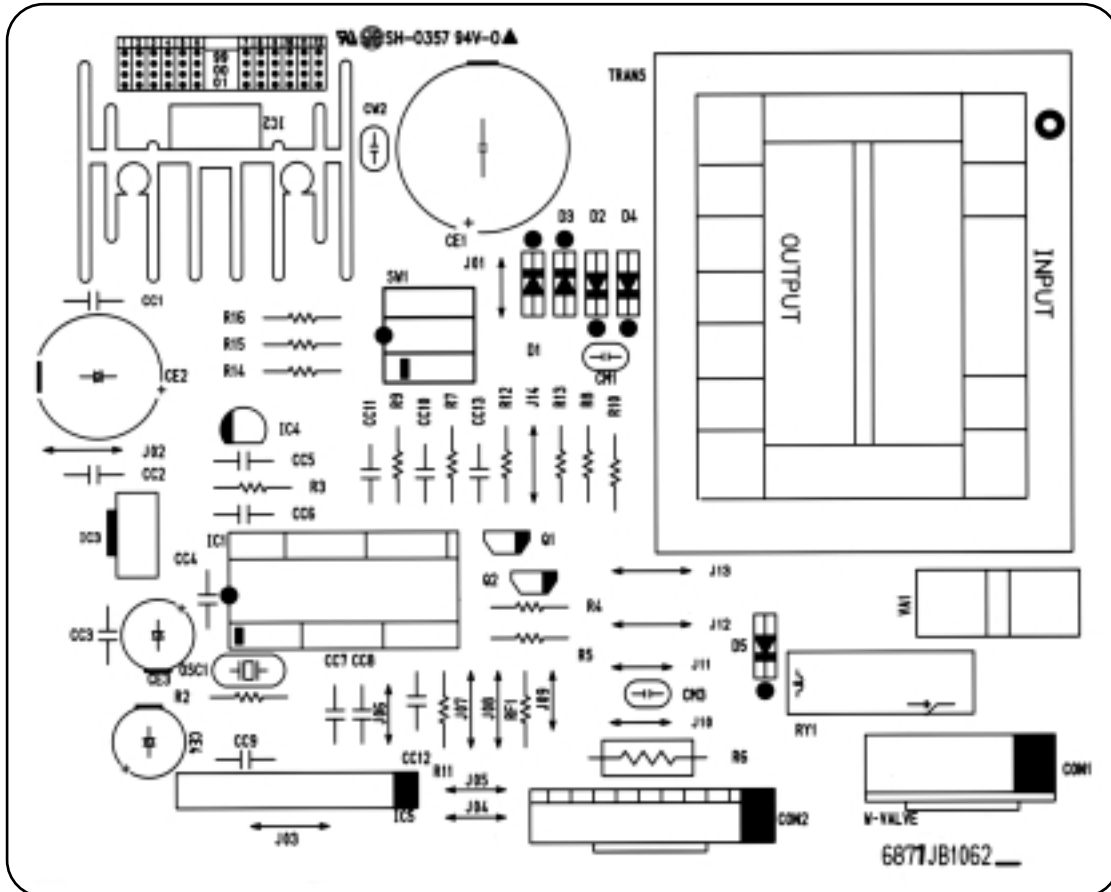



7-5-2 Replacement Part List

NO.	DWG. NO.	DESCRIPTION	SPEC'	MAKER	REMARK
1	6870JB2039	PWB,MAIN	FR-1(DS-1107A)	DOO SAN	t=1.6
2	6170JB2002	TRANS PCB	I: 117V, O: 15V	TAE SUNG	TRANS
3	6630JB8001B	WAFER	JE202-1I-03(SP-24)	JAE EUN	CON1
4	6630JB8004G		SMW250-08	YEON HO	CON2
5	6630JB8004D		SMW250-04		CON3
6	01ZZJB2004A		MICOM CHIP	TMP87C409N	TOSHIBA
8	01RH178050B 01KE780500A	REGULATOR	(1)BA17805T (2)KIA78S05P	ROHM KEC	IC3
9	01RH178120A 01NE781200B	REGULATOR	(1)BA17812T uPC7812AHF	ROHM NEC	IC2
10	01KE704200A 01KD010100A	RESET IC	K1A7042P BMR-0101D	K.E.C KODENSHI	IC4
11	6920JB2003A	RELAY	G5N-1	OMRON	RY1
12	J570-00012A J570-00012B	RESONATOR	CST4.00MGW CST4.00MGW-TF01	MURATA	OSC1 (=6212A09002B)
13	J572-00001C (=6102A09075A)	VARISTOR	(1)INR14D471	IL JIN	VA1
14	6102JB8001B		(2)SVC471D-14A	SAMHWA	
15	6102JB8001A		(1)INR14D621	IL JIN	
16	J572-00001D 6102JB8003A		(2)SVC621D-14A	SAMHWA	
			(1)SVC271D-14A	SAMHWA	
17	0DD414809BB	SWITCHING DIODE	1N4148	(1)P c (2)ROHM	D5
18	0DD400409CC	DIODE,RECTIFIER	1N4004	(1)P c (2)ROHM	D1~D4
19	6600JB8003A	DIP S/W	3P,DIP	OTAX	SW1
20	01RH622200A	DRIVE IC	BA6222	ROHM	IC5
21	OCE2286J618	ELE' CAPACITOR	2200uF/35V	(1)SAM HWA (2)SAM YOUNG	CE1
22	OCE1081H618		1000uF/25V		CE2
23	OCE1071H638		100uF/25V		CE4
24	OCE4771H618		470uF/25V		
25	OCE2271F638		220uF/16V		CE3
26	OCE4761H638		47uF/25V		
27	0CQ2231N409		MYL' CAPACITOR		223/100V
28	0CK1020H908	CER' CAPACITOR	102/25V	TAE YANG	
29	0CK2230H908		223/25V		
30	0CK1040H908		104/50V		CC1~12
31					
32	0RD0682H609	R,CARBON FILM	68J 1/2W	(1)JO YANG (2)K-OHM (3)DONG HO (4)SUNG YO	R6
33	0RD2001G608		2KJ 1/4W		R7,R9~11
34	0RD4701G609		4.7K 1/4W		R3~5,8 R14~16
35	0RD1004G608		1MJ 1/4W		R2
36	0RN1612G408		R,METAL FILM		16.2KF 1/4W
37					
38					
39	0TR106009AC	TRANSISTOR	KRA106M(KRA2206)	K.E.C	Q1
40	0TR102009AB	TRANSISTOR	KRC102M(KRC1202)	K.E.C	Q2
41	43607015	JUMP WIRE	0.6*5mm 0.6*8mm 0.6*10mm 0.6*12.5mm 0.6*15mm		J01,J04~J06 J09~J11,CC1,3 J02,J03,J07, J08,J12~J14
42	4920JB3003A	HEAT SINK(12V)	(=J572-00004A)		(IC2)
43	4920JB3001A	HEAT SINK(5V)	(=J572-00002A)		
44	1SBF0302418	SCREW	ASSEMBLE WITH H/SINK		
45	49111001	SOLDER	ALMIT KR-19RMA	HEE SUNG	SOLD'
46	49111004	SOLDER LEAD BAR	H63A		
47	59333105	FLUX AUTO	JS71	KOKI	
48					

7-6 PWB DIAGRAM

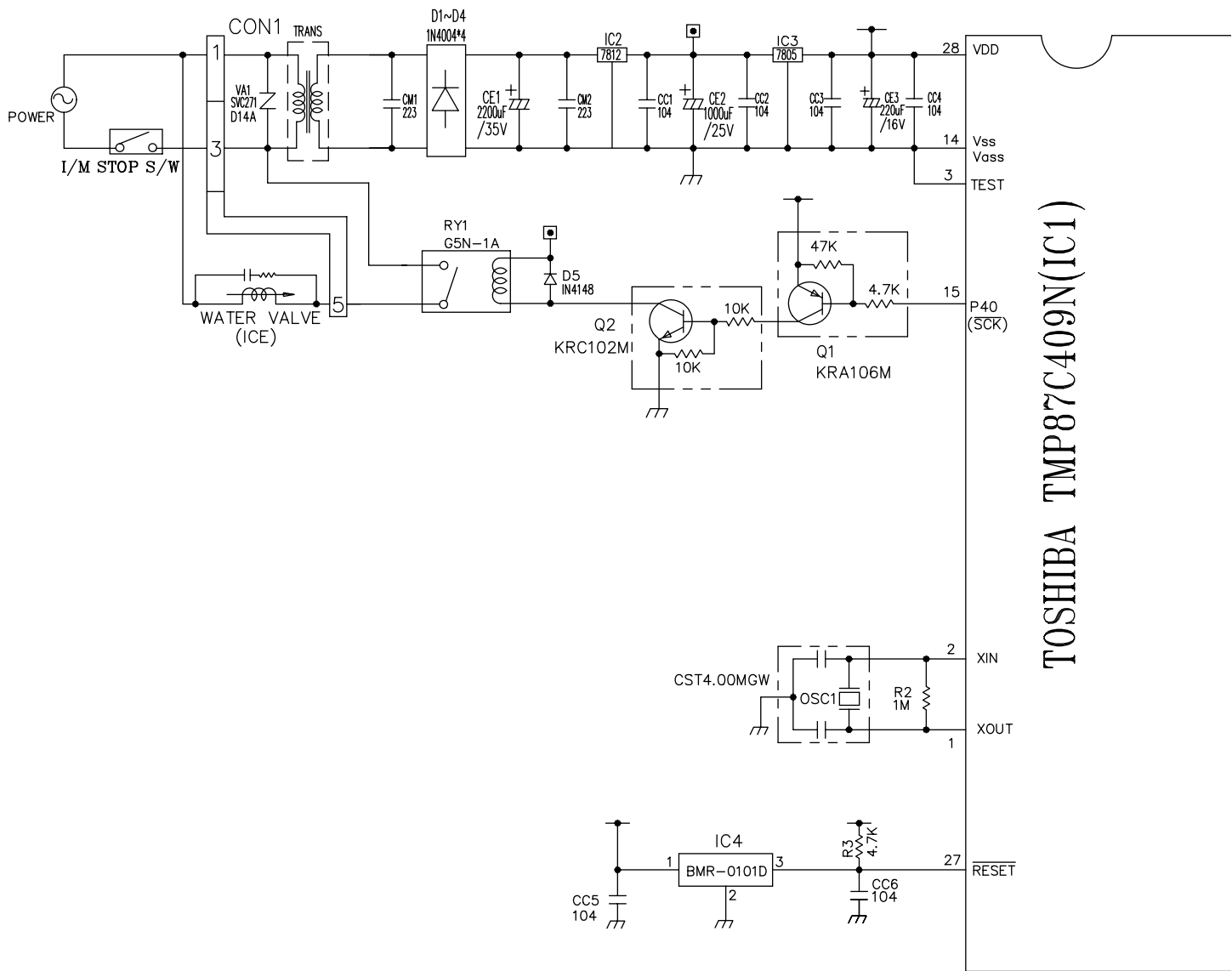

TOSHIBA TMP87C409N(IC1)

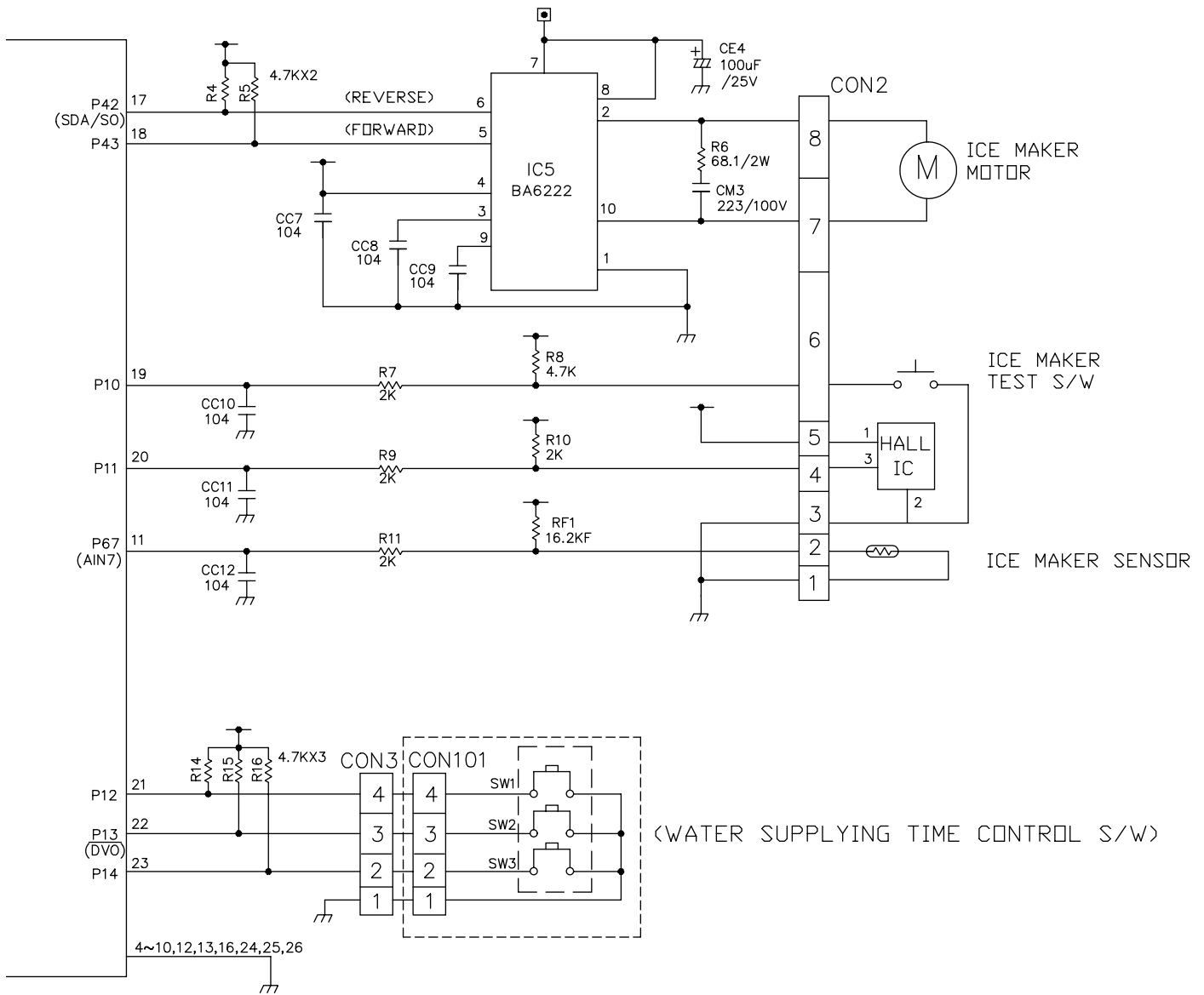



\* : Option

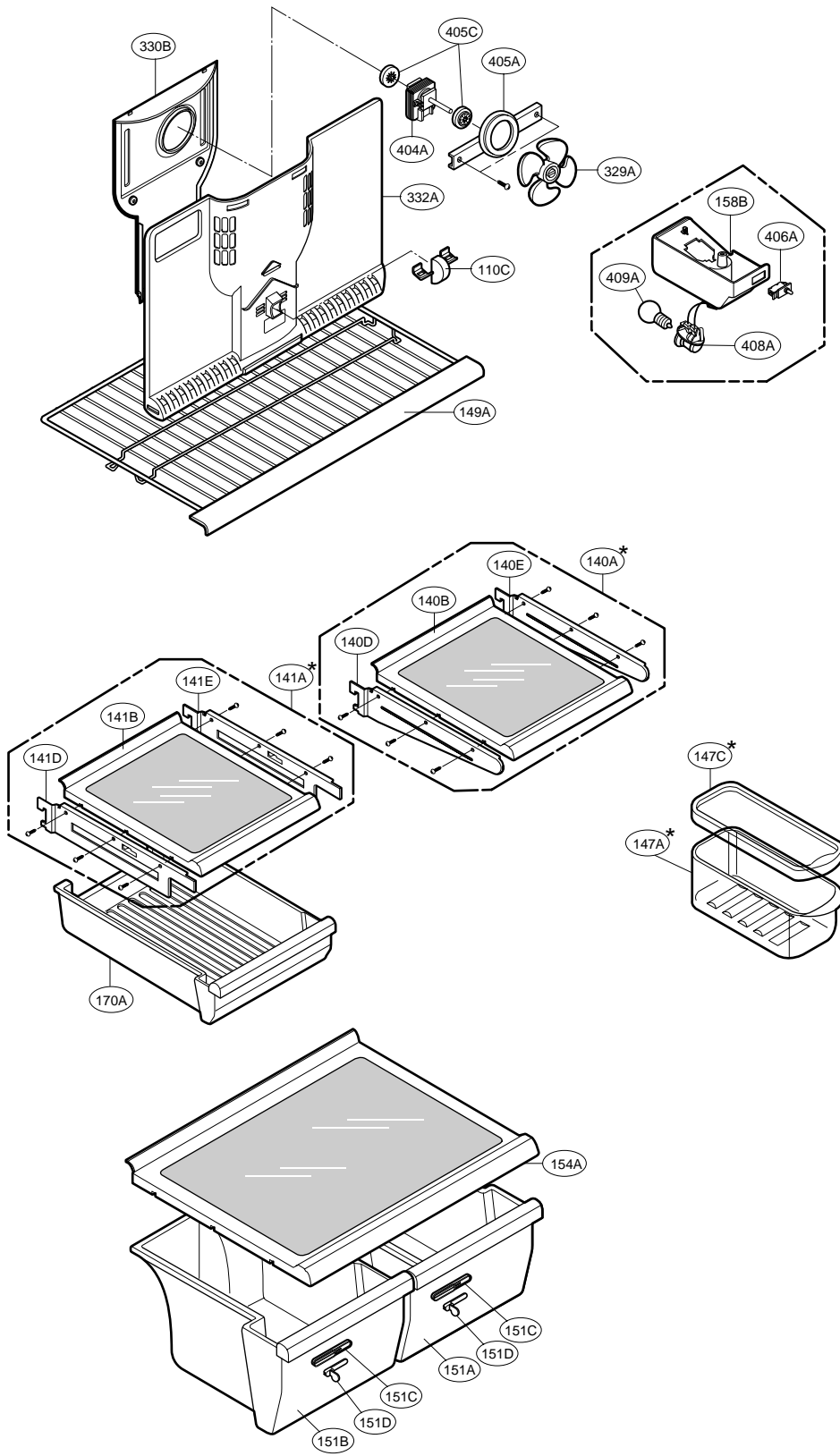

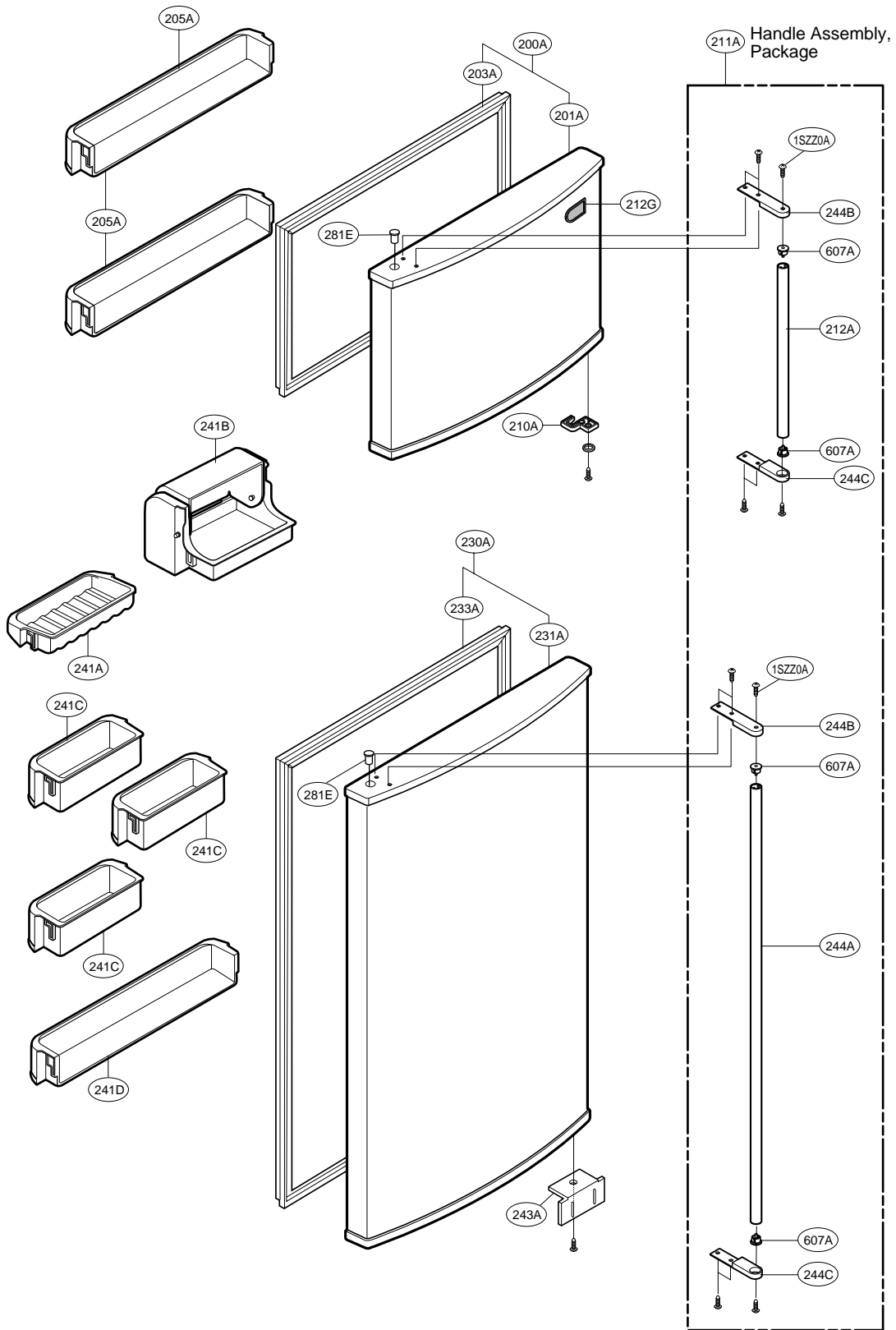

ICE MAKER PART

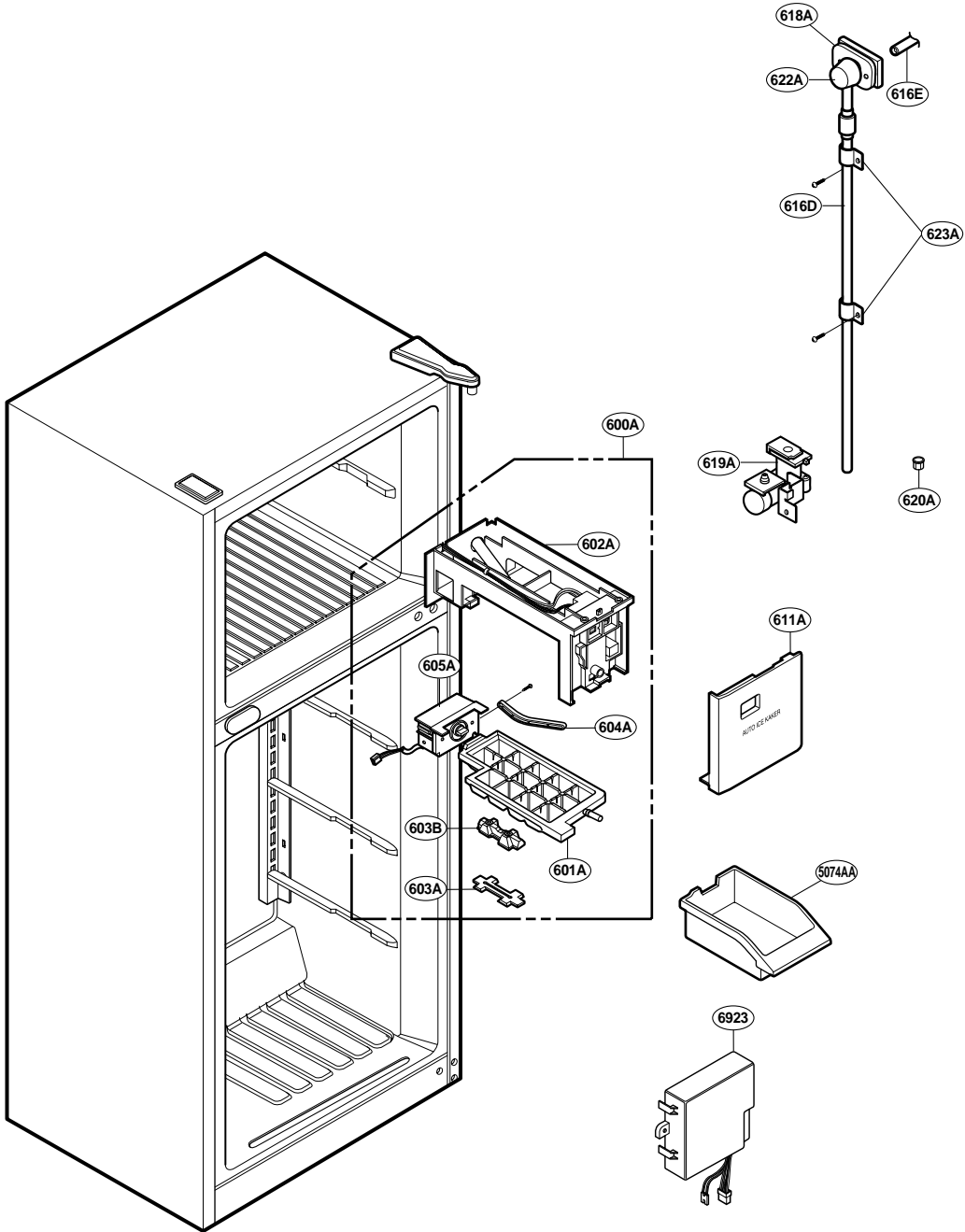

BUYER NAME:LGEUS      MODEL NAME:LRTBC1825T      LG REFERENCE NO:GR-T622ATC.ATICLGX  
 COLOR:TITANIUM

S	AL	LOCA.NO	PART NO(LG)	DESCRIPTION	SPECIFICATION	REMARK
		6923	6923JB1001A	MICOM ASSEMBLY		
		103A	3650JA2004U	HANDLE,BACK		
		103B	3650JA2004V	HANDLE,BACK		
		103C	3551JA2082D	COVER ASSEMBLY,LOWER		
		104A	4441JA3001A	CASTER ASSEMBLY		
	A	105A	5250JA2009A	DRAIN,PIPE-Z		
		106A	4779JA2003B	LEG ASSEMBLY,ADJUST		
		110A	6930JB1007C	THERMOSTAT		
		110C	4940JD1007C	KNOB,DAMPER		
		113B	4974JA2033A	GUIDE,DUCT		
		113C	4970JA3016A	SPRING,W		
		113D	4986JA2024A	GASKET,DOOR		
		120A	4995JA1024K	CONTROL BOX ASSEMBLY,R		
		120B	4994JD1037A	CONTROL BOX,R		
		120C	4940JD1006E	KNOB,DAMPER		
		140A	5027JA1041E	SHELF ASSEMBLY,NET		
		140B	5027JA1029F	SHELF ASSEMBLY,R		
		140D	5026JA2024E	SHELF,NET		
		140E	5026JA2024F	SHELF,NET		
		141A	5027JA1019Q	SHELF ASSEMBLY,R		
		141B	5027JA1029F	SHELF ASSEMBLY,R		
		141D	5026JA2020C	SHELF,NET		
		141E	5026JA2020F	SHELF,NET		
		145A	4930JA2032A	HOLDER,SHELF		
		145B	4930JA2031A	HOLDER,SHELF		
		149A	5026JA1108B	SHELF ASSEMBLY,F		
		151A	3391JA1036G	TRAY ASSEMBLY,VEGETABLE		
		151B	3391JA1036H	TRAY ASSEMBLY,VEGETABLE		
		151C	4940JA2012A	KNOB,DAMPER		
		151D	4940JA2011A	KNOB,DAMPER		
		154A	3551JA1027D	COVER ASSEMBLY,T/V		
		158B	4930JA1034A	HOLDER,LAMP		
		158C	3550JA2096A	COVER,LAMP		
		170A	3390JD1050G	TRAY,MEAT		
		1SZZ0A	1TCG0403232	SCREW TAPPING,COUNTER SUNK HEAD		
		200A	3581JA1045Q	DOOR ASSEMBLY,F		
	A	201A	5433JA0076F	DOOR FOAM ASSEMBLY,F		
		203A	4987JA1024A	GASKET ASSEMBLY,DOOR		
		205A	5004JD1110B	BASKET,DOOR		
		210A	4620JA2011A	STOPPER,DOOR		
		211A	3651JA2212A	HANDLE ASSEMBLY,PACKAGE		
		212A	3650JA2053A	HANDLE,F		



BUYER NAME:LGEUS      MODEL NAME:LRTBC1825T      LG REFERENCE NO:GR-T622ATC.ATICLGX  
 COLOR:TITANIUM

S	AL	LOCA.NO	PART NO(LG)	DESCRIPTION	SPECIFICATION	REMARK
		212G	4140JD2001C	NAME PLATE,P(H)		
	A	230A	3581JA8475C	DOOR ASSEMBLY,R		
		231A	5433JA0077L	DOOR FOAM ASSEMBLY,R		
		233A	4987JA1024B	GASKET ASSEMBLY,DOOR		
		241A	5004JD1119A	BASKET,DOOR		
		241B	5005JA1001B	BASKET ASSEMBLY,DOOR		
		241C	5004JD1112B	BASKET,DOOR		
		241D	5004JD1111B	BASKET,DOOR		
		243A	4620JA3010B	STOPPER,DOOR		
		244A	3650JA2054A	HANDLE,R		
		244B	3650JA2055A	HANDLE,DECO		
		244C	3650JA2056A	HANDLE,DECO		
		281A	3550JA2132K	COVER,HINGE		
		281B	4775JA2031B	HINGE ASSEMBLY,U		
		281E	5006JA3054H	CAP,HINGE		
		282B	4774JA2005A	HINGE ASSEMBLY,C		
		282C	1WPZJA3007A	WASHER,DRAWING		
		282E	5006JA2011U	CAP,HINGE		
		282H	5006JA2020B	CAP,HINGE		
		283B	4775JA2026A	HINGE ASSEMBLY,L		
		301A	5421JA1032A	EVAPORATOR ASSEMBLY		
		304A	3550JA1117A	COVER,BACK-M/C		
	A	307A	2521C-B6282	COMPRESSOR,ASSEMBLY	LA62LBCMC2 D DREF	
		308A	6748C-0004D	P.T.C ASSEMBLY	P6R8MD #250 MURATA	
		309A	6750C-0004M	O.L.P	4TM414KFBYY-520	
		310A	3550JA2087A	COVER,P.T.C		
		312A	5040JA3044A	RUBBER,SEAT		
		314A	4620JA3009A	STOPPER,COMP		
		315A	3103JA1015A	COMP BASE ASSEMBLY,STD		
		317A	5851JA2003B	DRIER		
		318A	J719-00006A	HOLDER,DRIER		
		319A	3390JA1115A	TRAY,DRIP		
		319C	4974JA1046A	GUIDE,FAN		
		323B	5403JA1026A	CONDENSER ASSEMBLY,WIRE		
		327A	4J04328A	RUBBER,DAMPING		
		328A	4J03020A	RUBBER,DAMPING		
		329A	J753-00011A	FAN ASSEMBLY		
		329C	5901JA1005B	FAN ASSEMBLY		
		330B	4998JA1010A	SHROUD,F		
		332A	3531JA1018L	GRILLE ASSEMBLY,FAN		
		334A	3550JA2095A	COVER,PIPE		
		334B	5040JA3039A	RUBBER,PIPE		

BUYER NAME:LGEUS      MODEL NAME:LRTBC1825T      LG REFERENCE NO:GR-T622ATC.ATICLGX  
 COLOR:TITANIUM

S	AL	LOCA.NO	PART NO(LG)	DESCRIPTION	SPECIFICATION	REMARK
		401A	6615JB2003F	CONTROLLER ASSEMBLY		
		404A	4681JB1011P	MOTOR ASSEMBLY,REF FAN		
		405A	4810JA3007A	BRACKET,MOTOR		
	A	405C	J756-00008B	RUBBER,MOTOR-N		
		406A	6600JB1005C	SWITCH,[PUSH]		
	A	406B	6600JB1002K	SWITCH,[PUSH]		
		408A	6621JB2005A	SOCKET ASSEMBLY,LAMP		
		409A	6912JB2004F	LAMP,[INCANDESCENT]	120V 25W	
		409B	6912JB2004C	LAMP,[INCANDESCENT]	125V 40W	
		410C	6914JB2006G	TIMER	120V	
		410G	0CBZJB2001E	CAPACITOR,DRAWING	250VAC 12UF	
		411A	6411JB1013B	POWER CORD ASSEMBLY		
		418A	5300JB1050R	HEATER,SHEATH	115V 270W	
		420A	4681JB1013G	MOTOR ASSEMBLY,REF FAN		
		5074AA	5074JA1023A	BANK,ICE		
		600A	5989JA1004B	ICE MAKER ASSEMBLY,KIT		
		601A	3390JA1118A	TRAY,ICE		
		602A	4810JA1022A	BRACKET,ICE MAKER		
		603A	3550JA3095A	COVER,SENSOR		
		603B	5410JA3011A	INSULATION,BACK		
		604A	4510JA3003A	LEVER,ICE MAKER		
		605A	5988JA1001A	ICE MAKER(MECH),UNIT		
		607A	4930JA3068A	HOLDER,BRACKET		
		611A	3551JA2074A	COVER ASSEMBLY,TRAY		
		616D	5210JA3005J	TUBE,PE		
		616E	5210JA3021A	TUBE,INJECT		
		618A	4810JA3036A	BRACKET,COVER		
		619A	5220JA2009D	VALVE,WATER		
		620A	1NZZJA3005A	NUT,DRAWING		
		620A	1NZZJA3005A	NUT,DRAWING		
		622A	5040JA3025A	RUBBER,INJECT		
		623A	4770JA3001A	BAND (MECH)		

BUYER NAME:LGEUS      MODEL NAME:LRTBC2025T      LG REFERENCE NO:GR-T722ATC.ATICLGX  
 COLOR:TITANIUM

S	AL	LOCA.NO	PART NO(LG)	DESCRIPTION	SPECIFICATION	REMARK
		6923	6923JB1001A	MICOM ASSEMBLY		
		103A	3650JA2004U	HANDLE,BACK		
		103B	3650JA2004V	HANDLE,BACK		
		103C	3551JA2082D	COVER ASSEMBLY,LOWER		
		104A	4441JA3001A	CASTER ASSEMBLY		
	A	105A	5250JA2009A	DRAIN,PIPE-Z		
		106A	4779JA2003B	LEG ASSEMBLY,ADJUST		
		110A	6930JB1007C	THERMOSTAT		
		110C	4940JD1007C	KNOB,DAMPER		
		113B	4974JA2033A	GUIDE,DUCT		
		113C	4970JA3016A	SPRING,W		
		113D	4986JA2024A	GASKET,DOOR		
		120A	4995JA1022H	CONTROL BOX ASSEMBLY,R		
		120B	4994JD1037B	CONTROL BOX,R		
		120C	4940JD1006E	KNOB,DAMPER		
		140A	5027JA1041J	SHELF ASSEMBLY,NET		
		140B	5027JA1030E	SHELF ASSEMBLY,R		
		140D	5026JA2016E	SHELF,NET		
		140E	5026JA2016F	SHELF,NET		
		141A	5027JA1019U	SHELF ASSEMBLY,R		
		141B	5027JA1030E	SHELF ASSEMBLY,R		
		141D	5026JA2012C	SHELF,NET		
		141E	5026JA2012F	SHELF,NET		
		145A	4930JA2032A	HOLDER,SHELF		
		145B	4930JA2031A	HOLDER,SHELF		
		147A	5074JA1008A	TRAY,EGG		
		147C	3550JA1077A	COVER,BANK		
		149A	5026JA1108A	SHELF ASSEMBLY,F		
		151A	3391JA1036G	TRAY ASSEMBLY,VEGETABLE		
		151B	3391JA1036H	TRAY ASSEMBLY,VEGETABLE		
		151C	4940JA2012A	KNOB,DAMPER		
		151D	4940JA2011A	KNOB,DAMPER		
		154A	3551JA1027D	COVER ASSEMBLY,T/V		
		158B	4930JA1034A	HOLDER,LAMP		
		158C	3550JA2096A	COVER,LAMP		
		170A	3390JD1050H	TRAY,MEAT		
		1SZZ0A	1TCG0403232	SCREW TAPPING,COUNTER SUNK HEAD		
		200A	3581JA1045Q	DOOR ASSEMBLY,F		
	A	201A	5433JA0076F	DOOR FOAM ASSEMBLY,F		
		203A	4987JA1024A	GASKET ASSEMBLY,DOOR		
		205A	5004JD1110B	BASKET,DOOR		
		210A	4620JA2011A	STOPPER,DOOR		

BUYER NAME:LGEUS      MODEL NAME:LRTBC2025T      LG REFERENCE NO:GR-T722ATC.ATICLGX  
 COLOR:TITANIUM

S	AL	LOCA.NO	PART NO(LG)	DESCRIPTION	SPECIFICATION	REMARK
		211A	3651JA2212A	HANDLE ASSEMBLY,PACKAGE		
		212A	3650JA2053A	HANDLE,F		
		212G	4140JD2001C	NAME PLATE,P(H)		
		230A	3581JA8475C	DOOR ASSEMBLY,R		
	A	231A	5433JA0077L	DOOR FOAM ASSEMBLY,R		
		233A	4987JA1024B	GASKET ASSEMBLY,DOOR		
		241A	5004JD1119A	BASKET,DOOR		
		241B	5005JA1001B	BASKET ASSEMBLY,DOOR		
		241C	5004JD1112B	BASKET,DOOR		
		241D	5004JD1111C	BASKET,DOOR		
		243A	4620JA3010B	STOPPER,DOOR		
		244A	3650JA2054A	HANDLE,R		
		244B	3650JA2055A	HANDLE,DECO		
		244C	3650JA2056A	HANDLE,DECO		
		281A	3550JA2132K	COVER,HINGE		
		281B	4775JA2031B	HINGE ASSEMBLY,U		
		281E	5006JA3054H	CAP,HINGE		
		282B	4774JA2005A	HINGE ASSEMBLY,C		
		282C	1WPZJA3007A	WASHER,DRAWING		
		282E	5006JA2011U	CAP,HINGE		
		282H	5006JA2020B	CAP,HINGE		
		283B	4775JA2026A	HINGE ASSEMBLY,L		
		301A	5421JA1032A	EVAPORATOR ASSEMBLY		
		304A	3550JA1117A	COVER,BACK-M/C		
		307A	2521JA1006C	COMPRESSOR,ASSEMBLY		
		308A	6748JA3001A	P.T.C		
		309A	6750JA3001A	O.L.P		
		310A	3550JA2158A	COVER,P.T.C		
		310B	4620JA3014A	STOPPER,CORD		
		312A	5040JA3044A	BUSHING,SEAT		
		314A	4620JA3009A	STOPPER,COMP		
		315A	3103JA1015B	COMP BASE ASSEMBLY,STD		
		317A	5851JA2003B	DRIER		
		318A	J719-00006A	HOLDER,DRIER		
		319A	3390JA1115A	TRAY,DRIP		
		319C	4974JA1046A	GUIDE,FAN		
		323B	5403JA1026A	CONDENSER ASSEMBLY,WIRE		
		328A	4J03020A	BUSHING,DAMPING		
		329A	J753-00011A	FAN ASSEMBLY		
		329C	5901JA1005B	FAN ASSEMBLY		
		330B	4998JA1010A	SHROUD,F		
		332A	3531JA1018L	GRILLE ASSEMBLY,FAN		

BUYER NAME:LGEUS      MODEL NAME:LRTBC2025T      LG REFERENCE NO:GR-T722ATC.ATICLGX  
 COLOR:TITANIUM

S	AL	LOCA.NO	PART NO(LG)	DESCRIPTION	SPECIFICATION	REMARK
		334A	3550JA2095A	COVER,PIPE		
		334B	5040JA3039A	BUSHING,PIPE		
		401A	6615JB2003F	CONTROLLER ASSEMBLY		
		404A	4681JB1011P	MOTOR ASSEMBLY,REF FAN		
		405A	4810JA3007A	BRACKET,MOTOR		
	A	405C	J756-00008B	BUSHING,MOTOR-N		
		406A	6600JB1005C	SWITCH,[PUSH]		
	A	406B	6600JB1002K	SWITCH,[PUSH]		
		408A	6621JB2005A	SOCKET ASSEMBLY,LAMP		
		409A	6912JB2004F	LAMP,[INCANDESCENT]	120V 25W	
		409B	6912JB2004C	LAMP,[INCANDESCENT]	125V 40W	
		410C	6914JB2006G	TIMER	120V	
		410G	0CBZJB2001E	CAPACITOR,DRAWING	250VAC 12UF	
		411A	6411JB1013B	POWER CORD ASSEMBLY		
		418A	5300JB1050R	HEATER,SHEATH	115V 270W	
		420A	4680JB1029A	MOTOR ASSEMBLY,REF FAN	115V/60HZ	
		5074AA	5074JA1023A	BANK,ICE		
		600A	5989JA1004B	ICE MAKER ASSEMBLY,KIT		
		601A	3390JA1118A	TRAY,ICE		
		602A	4810JA1022A	BRACKET,ICE MAKER		
		603A	3550JA3095A	COVER,SENSOR		
		603B	5410JA3011A	INSULATION,BACK		
		604A	4510JA3003A	LEVER,ICE MAKER		
		605A	5988JA1001A	ICE MAKER(MECH),UNIT		
		607A	4930JA3068A	HOLDER,BRACKET		
		611A	3551JA2074A	COVER ASSEMBLY,TRAY		
		616D	5210JA3005J	TUBE,PE		
		616E	5210JA3021A	TUBE,INJECT		
		618A	4810JA3036A	BRACKET,COVER		
		619A	5220JA2009D	VALVE,WATER		
		620A	1NZZJA3005A	NUT,DRAWING		
		620A	1NZZJA3005A	NUT,DRAWING		
		622A	5040JA3025A	BUSHING,INJECT		
		623A	4770JA3001A	BAND (MECH)		

