

SAMSUNG

SAMSUNG Home Appliance Service

***SERVICE* GUIDE**

Bottom-Mounted Freezer

**Model:
RB2055SL**

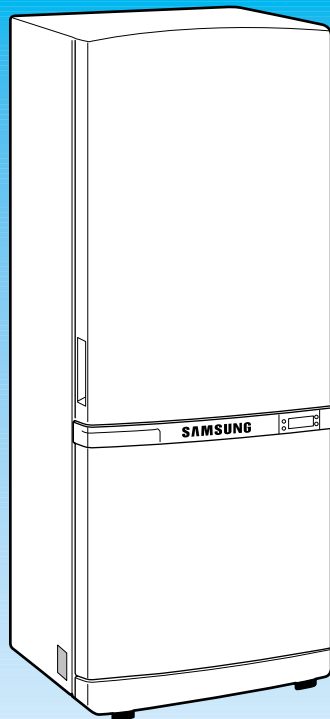

SAM0055



WARNING

IMPORTANT SAFETY NOTICE

The service guide is for service men with adequate backgrounds of electrical, electronic, and mechanical experience. Any attempt to repair a major appliance may result in personal injury and property damage. The manufacturer or dealer cannot be responsible for the interpretation of this information.

SAMSUNG ELECTRONICS AMERICA, INC.

Technical Service Guide

Copyright ©2004

All rights reserved. This service guide may not be reproduced in whole or in part in any form without written permission from the SAMSUNG ELECTRONICS Company.

Contents

1. Installation	4
2. Nomenclature	4
3. Product Specifications	5
4. Electrical part specifications & standard	5
5. Warranty information	7
6. Interior Views and Dimensions	8
7. Refrigeration Cycle and Cool Air Circulation Route	10
8. Mechanical Disassembly	12
9. Operation Function	19
13. Safety instruction on services	26
• Appendix I (Reference for circuit diagnostics)	27
• Appendix II (Circuit diagram)	30

1. INSTALLATION



- 1) **To protect refrigerator in movement**
Use padded hand truck from side only.
- 2) **Remove all protective tape and pad from the refrigerators.**
Connect power cord. Adjust the clearance between the doors.
- 3) **Temperature controls are preset in the factory for recommended settings.**
The refrigerator should run smoothly and lower the temperature gradually.
- 4) **Once the refrigerator temperature is sufficiently low**
It is recommended to store foods in the refrigerator.
It takes a few hours to reach the preset temperatures.

2. NOMENCLATURE

2002 Models

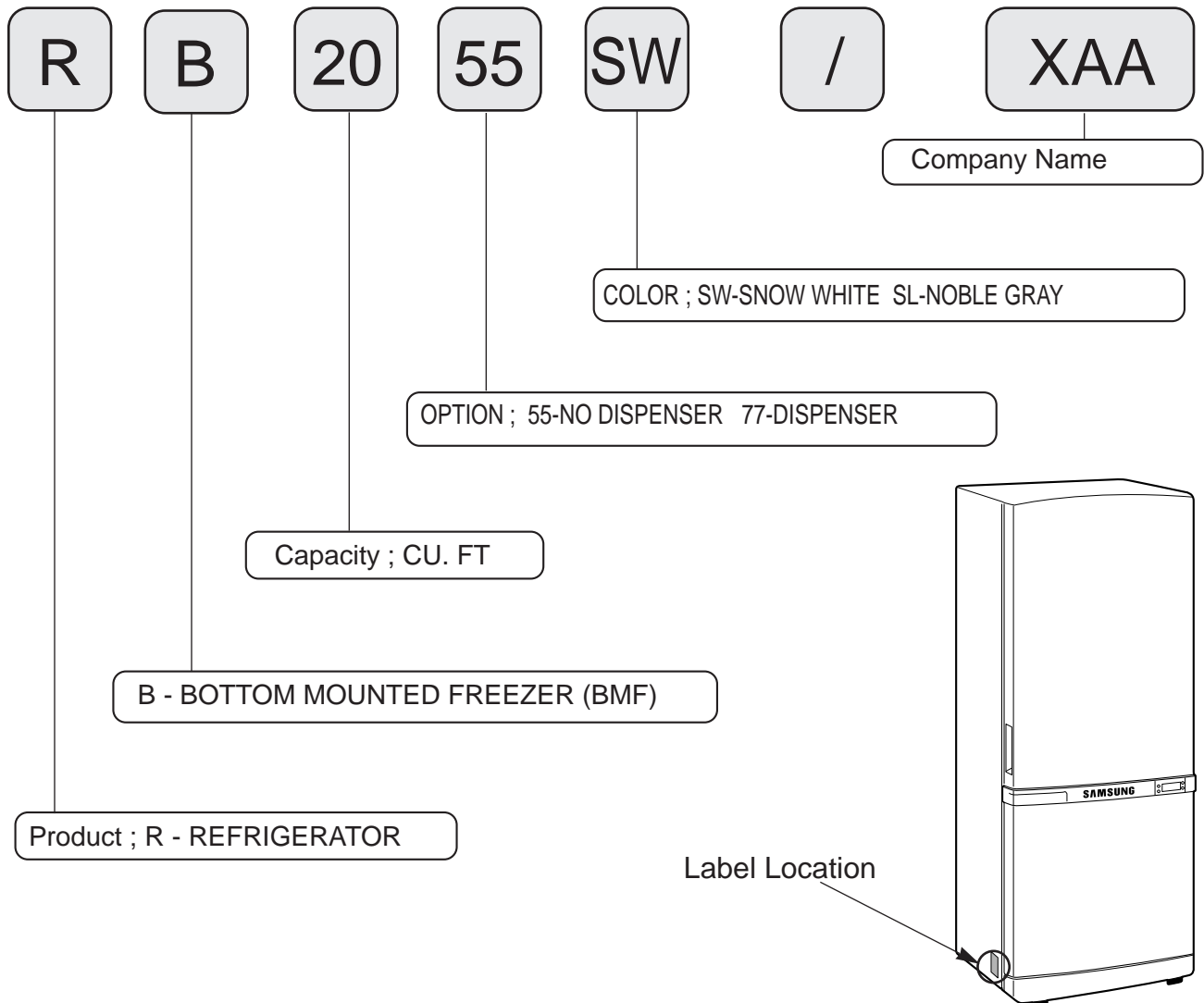

3. PRODUCT SPECIFICATIONS

Model		RB1855SW	RB1855SL	RB2055SW	RB2055SL
Type		BMF 2 Door			
Temperature control		Electronic control			
Net Capacity (ft ³)	Total	18.7	18.7	20.4	20.4
	Freezer	5.9	5.9	6.5	6.5
	Refrigerator	12.8	12.8	13.9	13.9
Net dimension (W x D x H)		32.3 x 28.3 x 69.9		32.3 x 30.3 x 69.9	
Foam	Cabinet insulation	CYCLO-PENTANE			
	Door insulation	CYCLO-PENTANE			
Liner	Cabinet	A.B.S			
	Door	A.B.S			
Net weight(lb)		227	227	241	241

4. ELECTRICAL PART SPECIFICATIONS & STANDARD

ITEM		STANDARD			
Model		RB1855SW	RB1855SL	RB2055SW	RB1855SL
Rated Voltage		115V			
Frequency		60HZ			
Compressor	Model	MK172C-L2U			
	Starting type	RSCR			
	Refrigerant	R134a			
	Oil Charge	Freol α-10c(Ester), 265cc			
Evaporator	Freezer	Split Fin & Tube Type			
	Refrigerator	Split Fin & Tube Type			
Condenser		Forced & Natural Convection Type			
Dryer		Molecular Sieve XH-9			
Capillary tube		ID0.82 x L3000			
Earth screw		BSBN(Brass screw)			
Door switch		AC125V 1.4A(SSD-6D)			

ELECTRICAL PART SPECIFICATIONS & STANDARD

ITEM			STANDARD		
Temperature	Freezer	Type	Temperature Selection	ON(°F)	OFF(°F)
		F-Sensor	-14°F	-12.0°F	-16.0°F
			-2°F	0°F	-4°F
	Refrigerator	R-Sensor	8°F	10°F	6°F
			34°F	36°F	32°F
		40°F	42°F	38°F	
Electrical parts	Defrosting	First Defrost Cycle (Concurrent Defrost of F and R)		4hr ±10min	
		Defrost Cycle(FRE)		Min. 12hrs, Max. 22Hrs	
		Defrost Cycle(REF)		Min. 6hrs, Max. 11Hrs	
		Pause Time		10±2min	
	Sensor	Freezer-Sensor		THERMISTOR (502AT), SPEC:5.0KΩ AT 77°F	
		Refrigerator-Sensor			
		FRE Evap-Sensor			
		REF Evap-Sensor			
		Ambient TEMP-Sensor			
	Heater	Defrost Heater(FRE)		242W	
		Drain Heater(FRE)		52W	
		Defrost Heater(REF)		120W	
		Drain Heater(REF)		38W	
	Fuse	Thermal-Fuse for preventing overheating of Freezer Defrost-Heater		AC250V 10A 77±5°C	
		Thermal-Fuse for preventing overheating of Freezer Defrost-Heater			
Capacitor	RUNNING	RSCR 250VAC, 12 μ F			
Over-Load Protector	MODEL	4TM437RHBYY-53			
	TEMP. ON	130±5			
STARTING- RELAY	TEMP. OFF	69±9			
	MODEL	J531Q33E100M200-2			
	OPERATION	10±20%			
MOTOR- FAN	FRE.	IS3210-SNP6D			
	REF.	IS3208-SNP6H			
	CIRCUIT	IS3208-SCH6A			
LAMP	FRE(INCANDESCENT)	110V-130V/15W			
	REF(INCANDESCENT)	110V-130/30W			

5. WARRANTY INFORMATION

SAMSUNG REFRIGERATOR (18 Cubic Feet and Larger Capacity)

LIMITED WARRANTY TO ORIGINAL PURCHASER

This SAMSUNG brand product, as supplied and distributed by Samsung Electronics America, Inc. (SAMSUNG) and delivered new, in the original carton to the original consumer purchaser, is warranted by SAMSUNG against manufacturing defects in materials and workmanship for a limited warranty period of:

One (1) Year Parts and Labor on Refrigerator
Five (5) Years Parts and Labor on Sealed Refrigeration System Only*
(*Compressor evaporator, condenser, drier, connecting tubing)

This limited warranty begins on the original date of purchase, and is valid only on products purchased and used in the United States. To receive warranty service, the purchaser must contact SAMSUNG for problem determination and service procedures. Warranty service can only be performed by a SAMSUNG authorized service center. The original dated bill of sale must be presented upon request as proof of purchase to SAMSUNG or SAMSUNG's authorized service center.

SAMSUNG will repair or replace any part found to be defective, at our option and at no charge as stipulated herein, with new or reconditioned parts during the limited warranty period specified above. All replaced parts and products become the property of SAMSUNG and must be returned to SAMSUNG. Replacement parts and products assume the remaining original warranty, or ninety (90) days, whichever is longer.

In-home service will be provided during the warranty labor period subject to availability within the contiguous United States. In-home service is not available in all areas. To receive in-home service, the product must be unobstructed and accessible from floor level to service personnel. If during in-home service repair cannot be completed, it may be necessary to remove, repair and return the product. If in-home service is unavailable, SAMSUNG may elect, at our option, to provide for transportation of our choice to and from a SAMSUNG authorized service center. Otherwise, transportation to and from the SAMSUNG authorized service center is the responsibility of the purchaser.

This limited warranty covers manufacturing defects in materials and workmanship encountered in normal, noncommercial use of this product, and shall not apply to the following, including, but not limited to: damage which occurs in shipment; delivery and installation; applications and uses for which this product was not intended; altered product or serial numbers; cosmetic damage or exterior finish; accidents, abuse, neglect, fire, water, lightning or other acts of nature; use of products, equipment, systems, utilities, services, parts, supplies, accessories, applications, installations, repairs, external plumbing and leaks, external wiring, circuit breakers, fuses or connectors not supplied and authorized by SAMSUNG, or which damage this product or result in service problems; incorrect electrical line voltage, fluctuations and surges; customer adjustments and failure to follow operating instructions, cleaning, maintenance and environmental instructions that are covered and prescribed in the instruction book; loss of food due to spoilage; consumable items including filters and light bulbs.

THERE ARE NO EXPRESS WARRANTIES OTHER THAN THOSE LISTED AND DESCRIBED ABOVE, AND NO WARRANTIES WHETHER EXPRESS OR IMPLIED, INCLUDING, BUT NOT LIMITED TO, ANY IMPLIED WARRANTIES OF MERCHANTABILITY OR FITNESS FOR A PARTICULAR PURPOSE, SHALL APPLY AFTER THE EXPRESS WARRANTY PERIODS STATED ABOVE, AND NO OTHER EXPRESS WARRANTY OR GUARANTEE GIVEN BY ANY PERSON, FIRM OR CORPORATION WITH RESPECT TO THIS PRODUCT SHALL BE BINDING ON SAMSUNG. SAMSUNG SHALL NOT BE LIABLE FOR LOSS OF REVENUE OR PROFITS, FAILURE TO REALIZE SAVINGS OR OTHER BENEFITS, OR ANY OTHER SPECIAL, INCIDENTAL OR CONSEQUENTIAL DAMAGES CAUSED BY THE USE, MISUSE OR INABILITY TO USE THIS PRODUCT, REGARDLESS OF THE LEGAL THEORY ON WHICH THE CLAIM IS BASED, AND EVEN IF SAMSUNG HAS BEEN ADVISED OF THE POSSIBILITY OF SUCH DAMAGES. NOR SHALL RECOVERY OF ANY KIND AGAINST SAMSUNG BE GREATER IN AMOUNT THAN THE PURCHASE PRICE OF THE PRODUCT SOLD BY SAMSUNG AND CAUSING THE ALLEGED DAMAGE. WITHOUT LIMITING THE FOREGOING, PURCHASER ASSUMES ALL RISK AND LIABILITY FOR LOSS, DAMAGE OR INJURY TO PURCHASER AND PURCHASER'S PROPERTY AND TO OTHERS AND THEIR PROPERTY ARISING OUT OF THE USE, MISUSE OR INABILITY TO USE THIS PRODUCT SOLD BY SAMSUNG NOT CAUSED DIRECTLY BY THE NEGLIGENCE OF SAMSUNG. THIS LIMITED WARRANTY SHALL NOT EXTEND TO ANYONE OTHER THAN THE ORIGINAL PURCHASER OF THIS PRODUCT, IS NONTRANSFERABLE AND STATES YOUR EXCLUSIVE REMEDY.

Some states do not allow limitations on how long an implied warranty lasts, or the exclusion or limitation of incidental or consequential damages, so the above limitations or exclusions may not apply to you. This warranty gives you specific legal rights, and you may also have other rights, which vary from state to state.

To obtain warranty service, please contact SAMSUNG at:

SAMSUNG CUSTOMER CARE CENTER
400 Valley Road, Suite 201, Mt. Arlington, NJ 07856, Tel: 973-601-6000, Fax: 973-601-6001
1-800-SAMSUNG (1-800-726-7864) and www.SAMSUNGUSA.com

6. Interior Views and Dimensions

6-1) Shelves and Bins

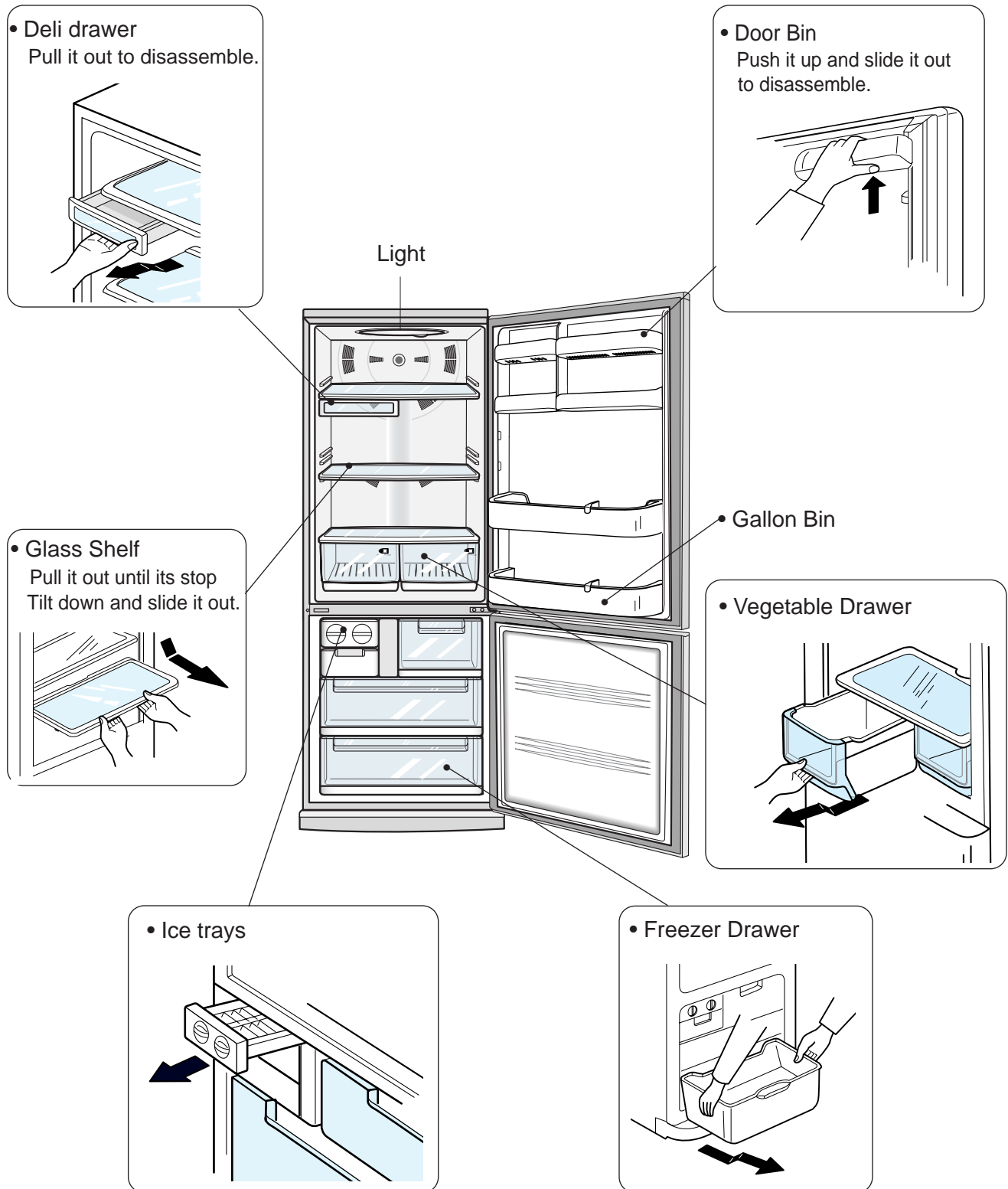

Interior Views and Dimensions

6-2) Dimensions of Refrigerator (Inches)

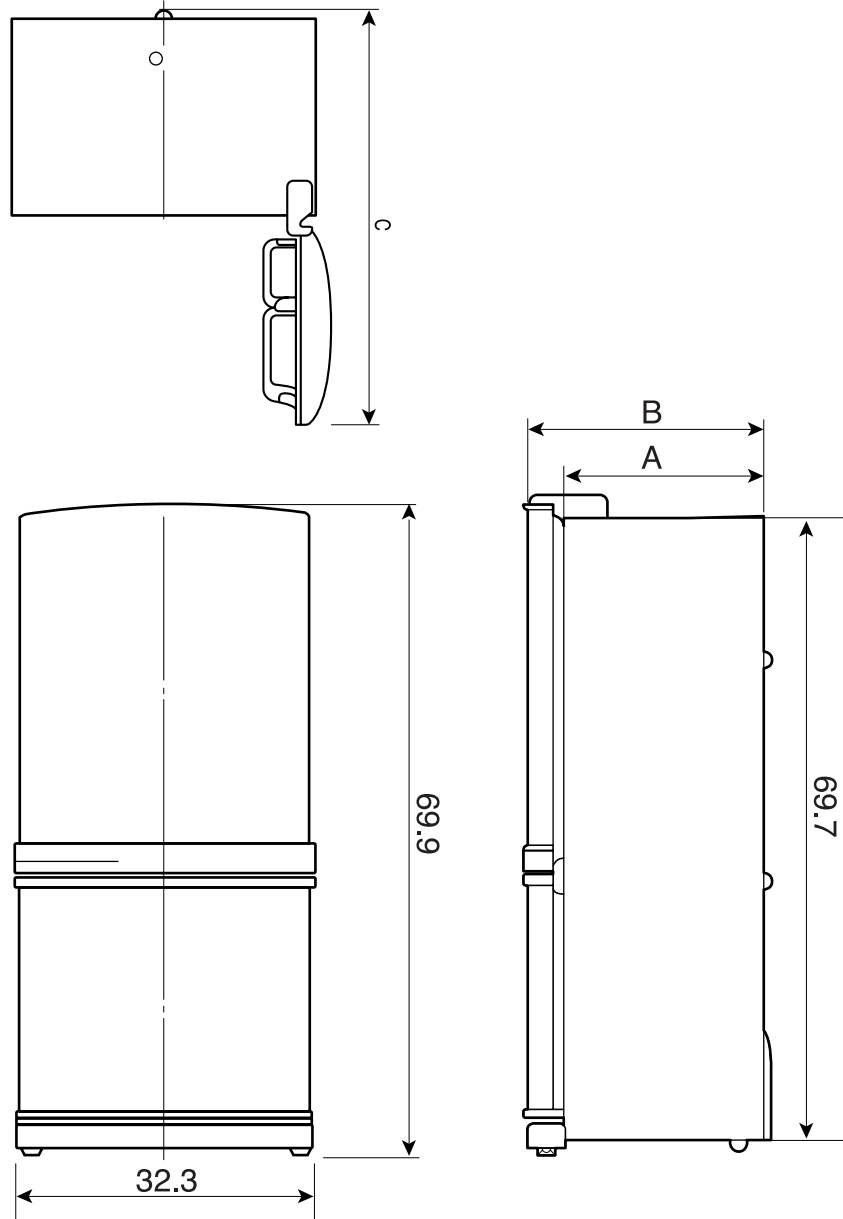

MODEL	A	B	C
RB1855	24.3	28.3	57.8
RB2055	26.3	30.3	59.8

7. Refrigeration Cycle and Cool Air Circulation Route

7-1) Refrigerant Route in Refrigeration cycle

Compressor → Sub condenser → Cluster pipe → Hot pipe → Dryer → Capillary tube → R-Evaporator → F-Evaporator → Accumulator → Suction pipe → Compressor

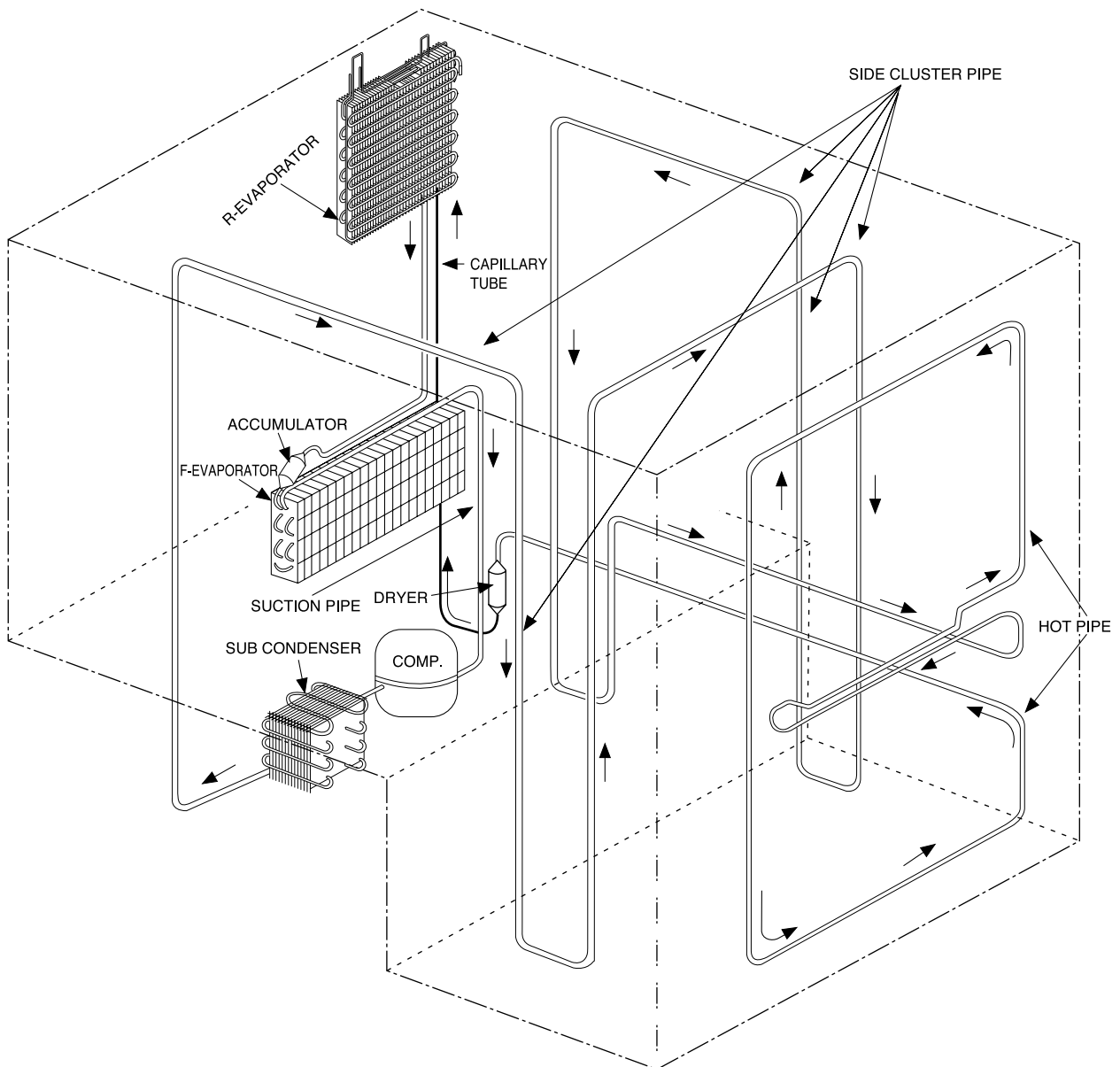

Refrigeration Cycle and Cool Air Circulation Route

7-2) Cool Air Circulation

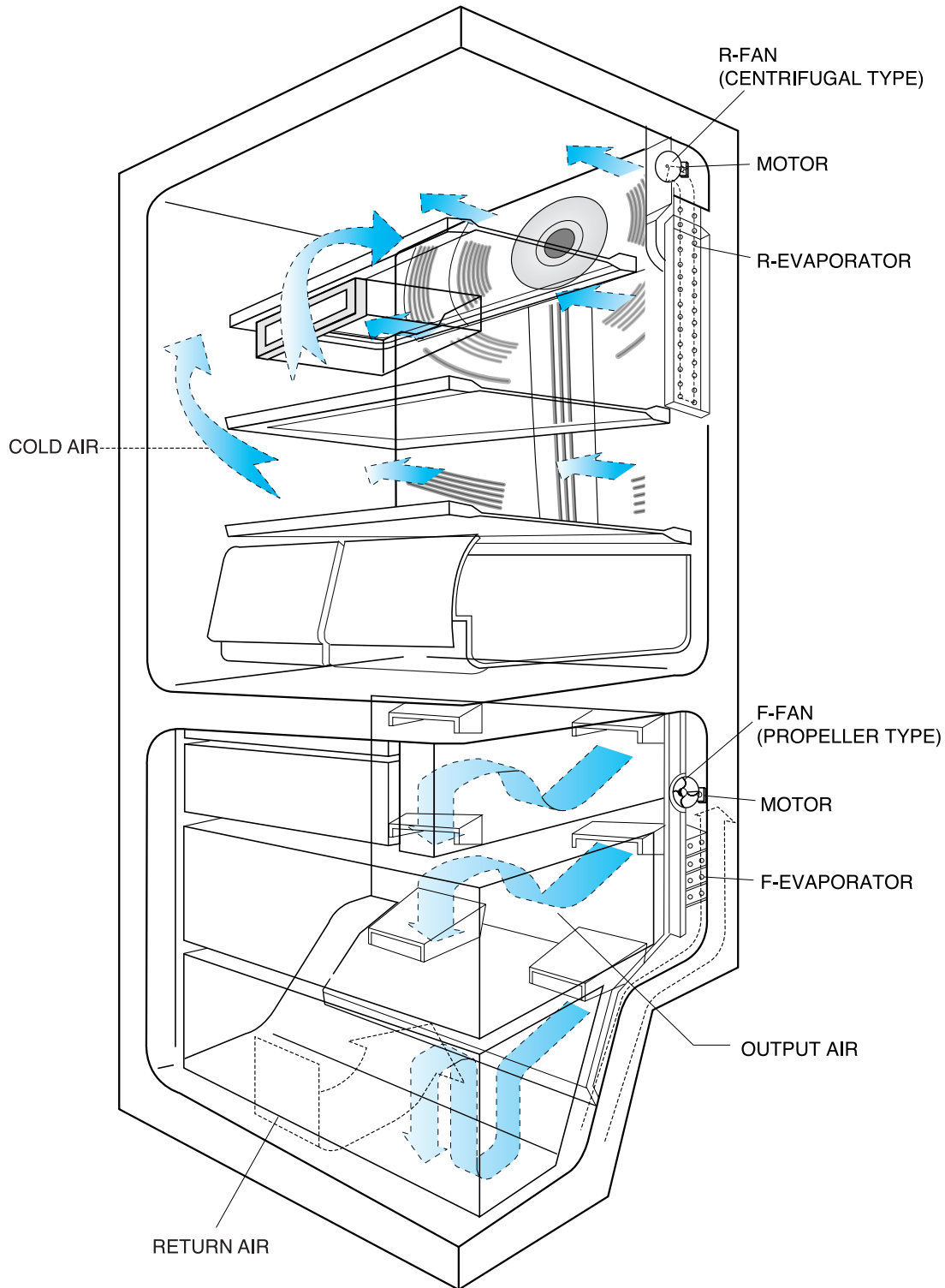

8. Mechanical Disassembly

Refrigerator Disassembly

Control Panel	13
Refrigerator Light	14
Freezer Light	14
Evaporator Cover in the Refrigerator	15
Evaporator Cover in the Freezer	16
Evaporator in the Freezer	17
Evaporator in the Refrigerator	17
Machine Compartment & Electric Box	18

Mechanical Disassembly

Control Panel

1. Remove the screws.
2. Pull out the control panel.
3. Disconnect the wire connector.

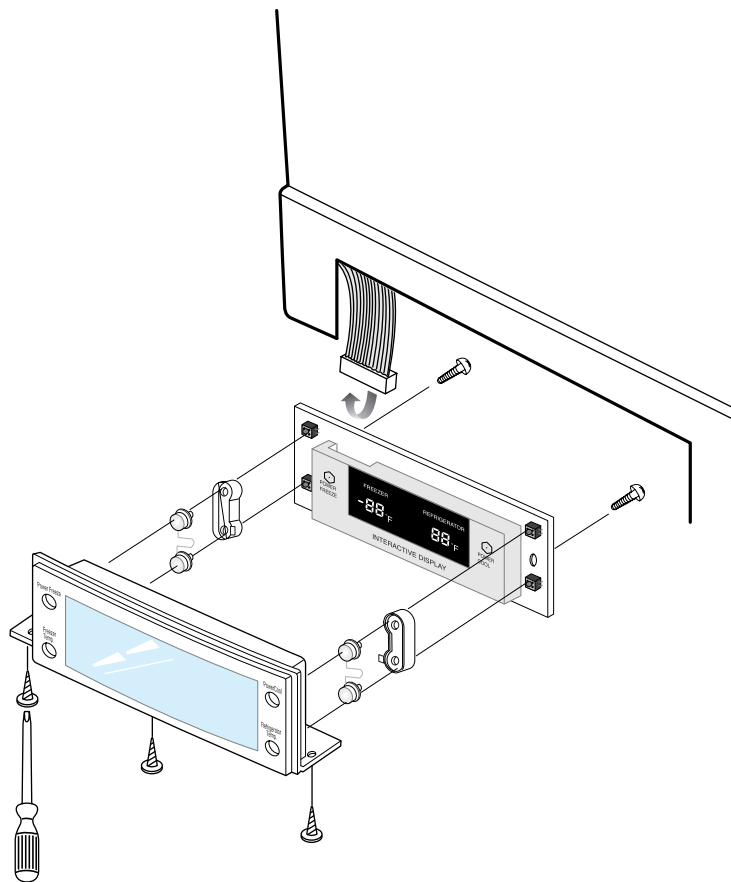

Mechanical Disassembly



Always unplug the power cord before replacing the refrigerator lamp.
There is the danger of electric shock.

Refrigerator Light

1. Remove the screw.



2. Remove the lamp cover by unlocking the tabs and pulling the cover down.



3. Replace the lightbulb by turning it counter-clockwise.



4. After replacing the bulb, reattach the cover and screw it again.
5. Plug the power cord in and check the lamp by pressing the R-door switch.

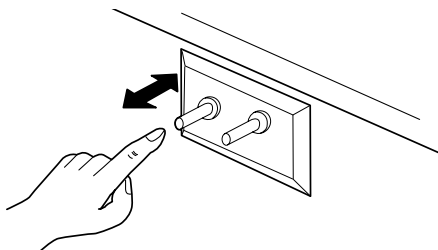

Freezer Light

1. Remove the cover by pressing the bottom tab.

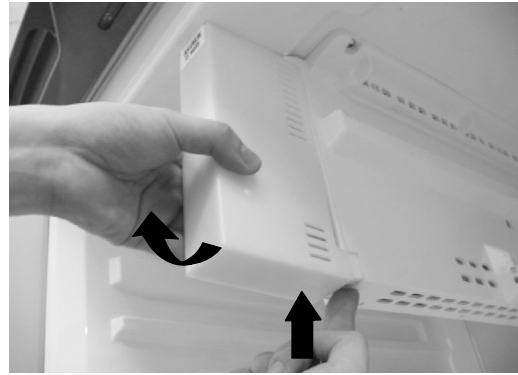

2. Replace the lightbulb by turning it counter-clockwise.

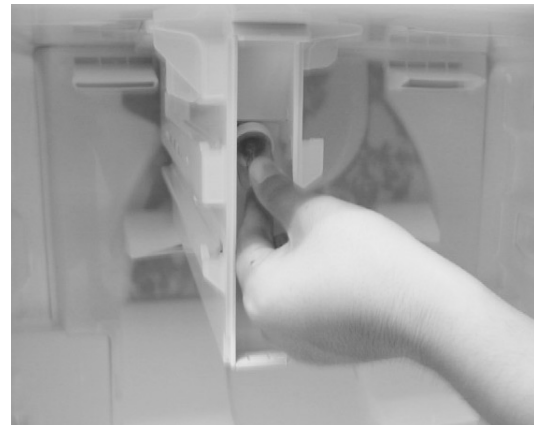

3. Reattach the cover and check the lamp by pressing door switch.

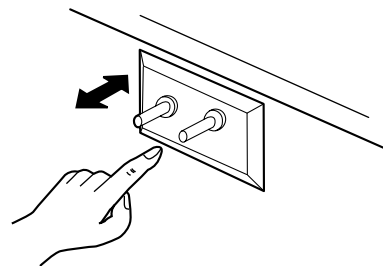

Mechanical Disassembly

Evaporator Cover in the Refrigerator

1. Remove all shelves and drawers from the refrigerator.

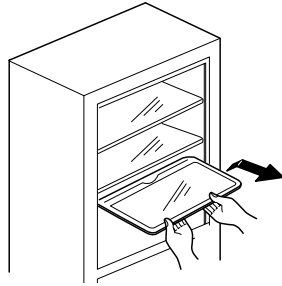

2. Pull out the screw caps with a small flat-blade screwdriver.
3. Remove 6 Phillips screws from the cover.

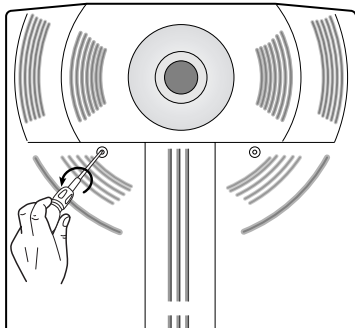

4. Unlock the 2 tabs with a flat-blade screwdriver on each side of the bottom cover.
5. Remove the evaporator cover by pulling out from the bottom of the evaporator cover.

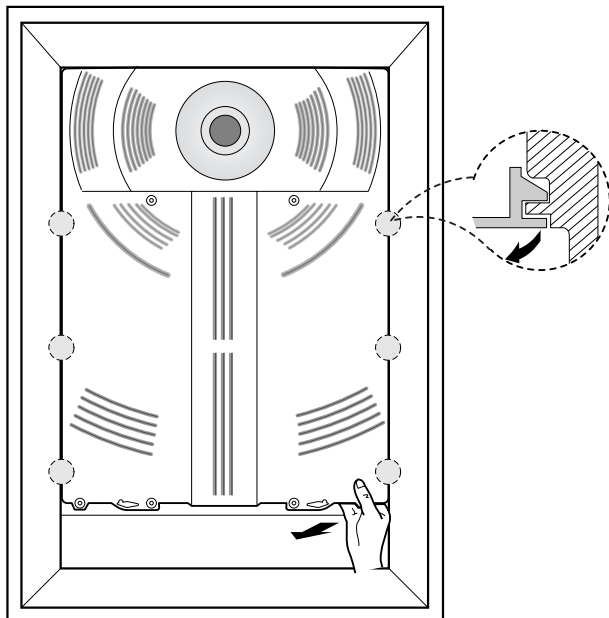

6. Disconnect the wire connector.

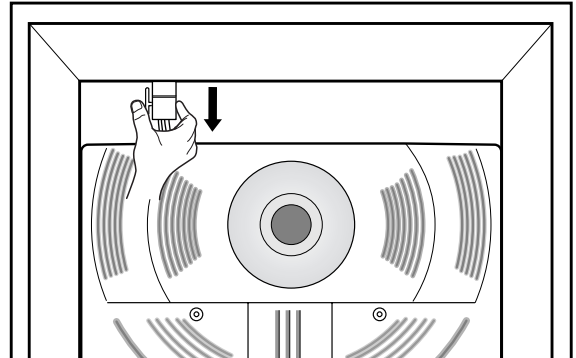

- Ductwork of the evaporator fan assembly.

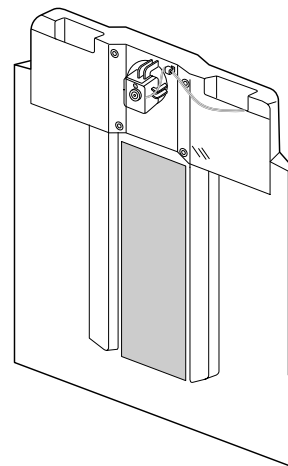

Mechanical Disassembly

Evaporator Cover in Freezer

1. Remove all drawers from the freezer.

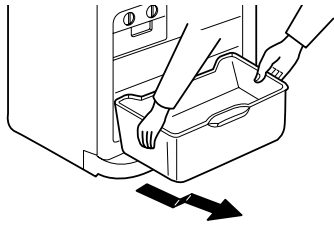

2. Remove screws (2) from the support rail.

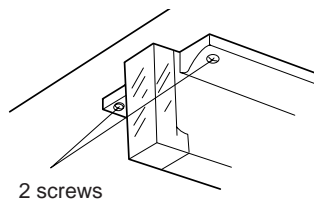

3. Pull down the holder of the support rail and disconnect the wire connector to remove it.

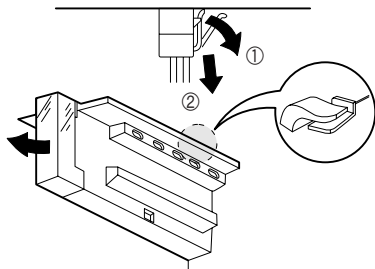

4. Unlock the tabs around the evaporator cover from the bottom.

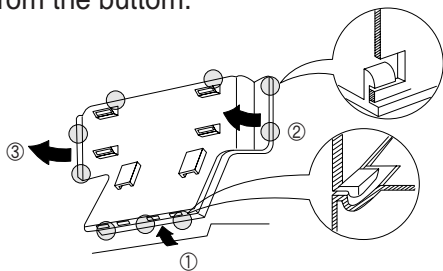

5. Disconnect wire connector from the top-left corner.

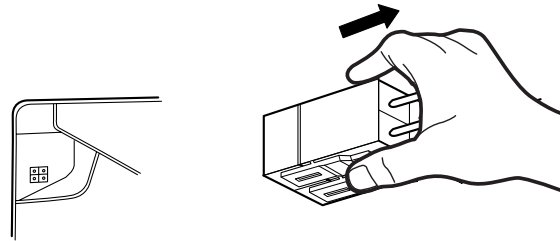

6. Remove 2 screws from the rear cover of the freezer evaporator and unlock the tabs to remove it.

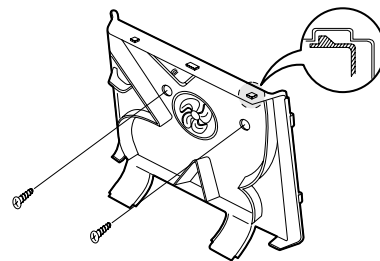

Mechanical Disassembly

Evaporator in Refrigerator

Evaporator is located in the bottom of refrigerator.

1. Take off the ductwork in refrigerator.
2. Disconnect the wire connector.(Heater and Thermistor)
3. Desolder the capillary tube and the suction line from the evaporator.
4. Remove the evaporator.
5. With a file, score the capillary tube just upstream of the soldered point. Break off the soldered section to help prevent solder from plugging the tube during soldering.
6. Place a new evaporator and braze the suction and capillary tube to evaporator using silver solder.
7. Install a replacement dryer.
8. Evacuate and recharge the system using reasonable procedures.

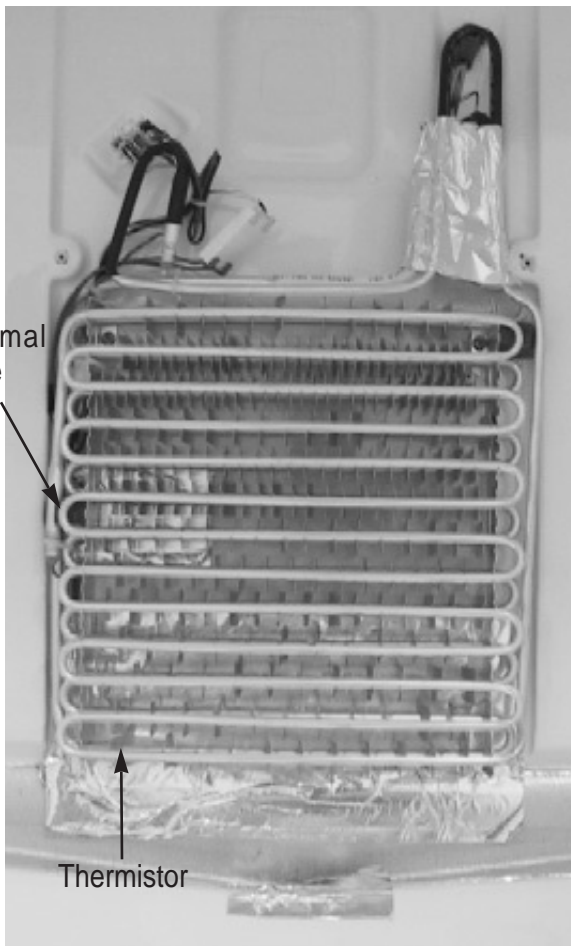

Evaporator in Freezer

Evaporator is located in the bottom of freezer to produce cold air driven across the evaporator coils.

1. Take off the ductwork in Freezer.
2. Disconnect the wire connector (Heater, Bimetal, and Thermistor).
3. Desolder the inlet and outlet tubes.
4. Remove the evaporator.
5. Take the same steps to seal the system as mentioned earlier.

Accumulator

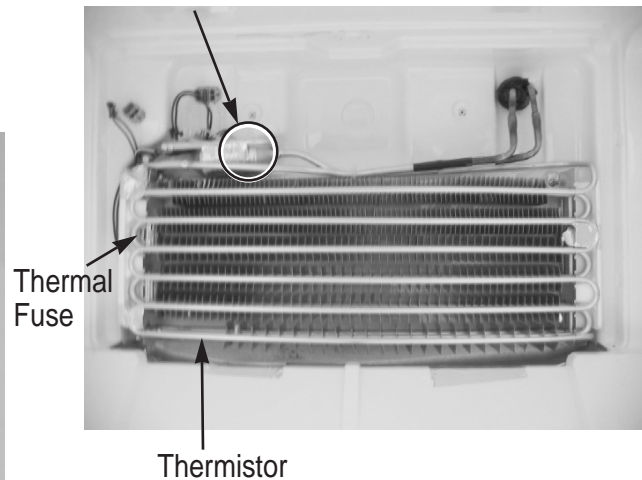

Mechanical Disassembly

Machine Compartment & Electric Box



Warning

Make sure the power cord is unplugged before replacing any electric components.

1. Unplug the power cord.

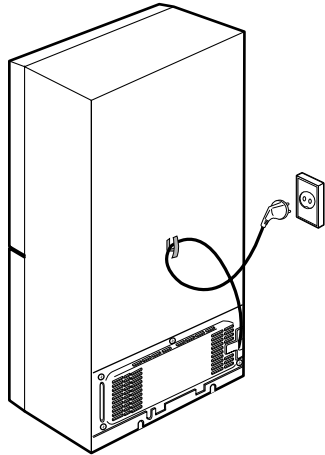

2. Remove the screws of the compartment cover. Slide it up and take out from the refrigerator.

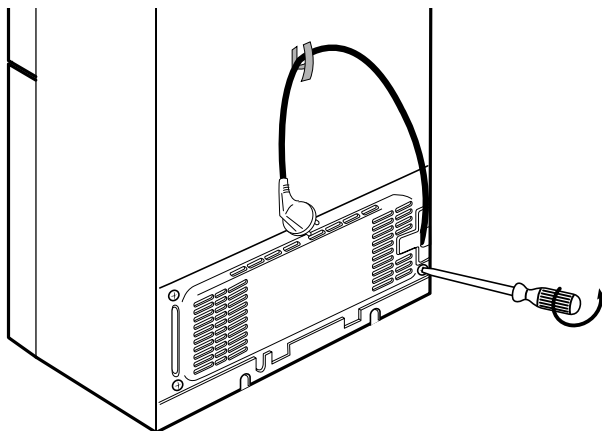

3. Machine compartment assembly

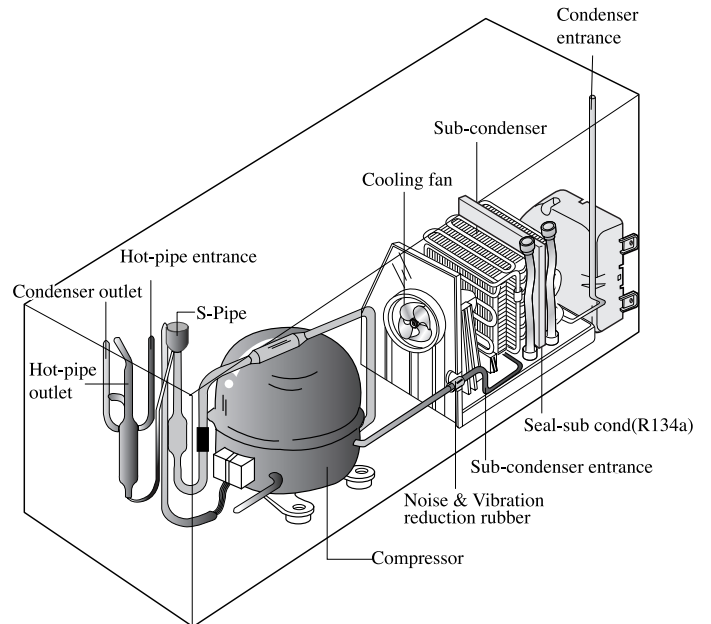

4. Disassemble the electric box cover after removing the screws with a Phillips screwdriver.

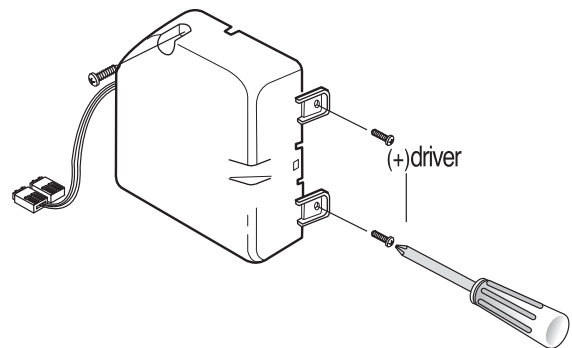

5. Electric box assembly

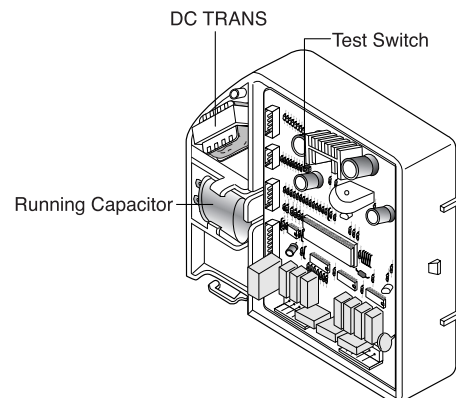

9. Operation Function

9-1) Digital Panel	20
9-2) Temperature Control Function	20
9-3) Power Freeze and Power cool Functions	20
9-4) Sound Function	21
9-5) Defrost Function	21
9-6) Forced Operation Function	22
9-7) Power failure compensating Function	23
9-8) Exhibition Function	23
9-9) Self - Diagnostics Function	23
9-10) Component Load Operation Function.	24
9-11) C-Fan Motor Delay function	25

Operation Function

9-1) Digital Panel

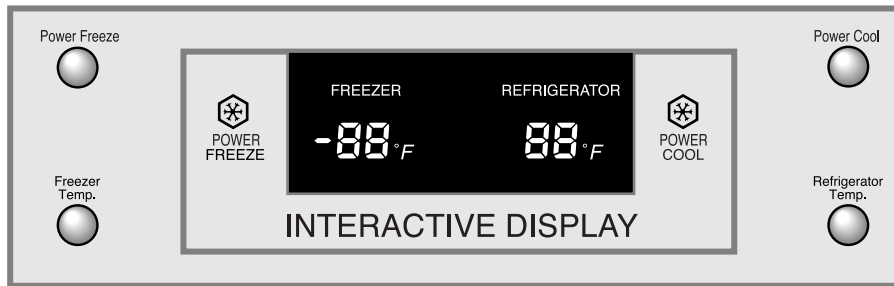

9-2) Temperature Control Function

When the system power is initially engaged, the default set temperatures are -2°F for the freezer and 38°F for the refrigerator, respectively. The numbers shown on the digital display panel stand for the actual compartment temperatures. When the compartment temperatures go down, so do the numbers on the display panel, and finally they reach the set temperatures. Once the system is stabilized, the display temperatures are the set temperature.

1) Freezer Temperature Control.

To select a set temperature, press the Freezer Temp. button. The display shows the set temperature from -14°F to 8°F in sequence.

2) Refrigerator Temperature Control.

To select a set temperature, press the Refrigerator Temp. button. The display shows the set temperature from 34°F to 46°F in sequence.

note) Because of the temperature sensor sensitivity, the refrigerator can be under and/or over cooled when the air flow is blocked by stored foods. (Temperature range of the sensor : $15^{\circ}\text{F} \sim 80^{\circ}\text{F}$)
In the event of a power failure, if the freezer temperature is maintained lower than 41°F , the last selected set temperature and functions memorized in EEPROM will be restored when the power is on.

9-3) Power Freeze Function and Power Cool Functions.

- Select the Power Freeze or Power Cool buttons separately.
- These buttons are toggled ON and OFF and the indicators as well.
- Although you select Power Freeze or Power Cool, the set temperatures in the freezer and refrigerator are not changed.
- The set temperatures for the compartments can be changed while these functions are in use.

1) Power Freeze function

- 1-1) When you press the Power Freeze button, the LED indicator lights right away, but there is 10 seconds lag time to an actual operation. When this button is pressed again, the Power Freeze function stops and the indicator is off immediately.
- 1-2) If you select Power Freeze, both the compressor and the freezer fan run for $2 \frac{1}{2}$ hours continuously.
- 1-3) During Power Freeze, the freezer retains the current settings.
- 1-4) When Power Freeze expires, the indicator goes off and the freezer set temperature will be restored.

2) Power Cool function

- 2-1) Power Cool operation and the indicator work exactly same as the Power Freeze function.
- 2-2) When Power Cool is selected, COMP and R-FAN operate continuously until the refrigerator reaches 25°F . This function will be terminated after $2 \frac{1}{2}$ hr running.

Operation Function

- 3) When you select Power Freeze and Power Cool together
Each function works at the same time. The COMP and F-FAN run continuously and the R-FAN runs until 25°F in the refrigerator.
- 4) Initial Power-On
 - 4-1) When the freezer and the refrigerator temperatures are higher than 14°F and 50°F, respectively, if Power Freeze is selected, then the R-FAN will be off. If Power Cool is selected, then the F-FAN will be off.
 - 4-2) When both functions are selected, there is no benefit of fast cooling for each compartment.

9-4) Sound Function

- 1) Sound function
 - 1-1) To make sure a command input, whenever a button is pressed, a “ding-dong” sounds.
 - 1-2) When two or more buttons are pressed simultaneously or if a wrong button is pressed, there is no sound.
- 2) Door Open Alarm
 - 2-1) When the doors remain open for 2 minutes, there are 10 times beeps.
 - 2-2) If the doors continue to remain open more than 2 minutes, the additional 10 beeps interval will change to 1 minute.
 - 2-3) The beeps will cease immediately when the doors are closed.

9-5) Defrost Function

- 1) A defrost is determined based on the accumulated compressor on-time.
- 2) When the power is engaged for the first time, the defrost cycle for the freezer and the refrigerator will begin after 4 hours of the accumulated compressor on-time.
- 3) A defrost interval depends on the ambient temperature, the number of door openings, and the door open time.
- 4) The defrost cycle is composed of a pre-cool process (F-Fan and COMP) for 30 minutes, a heating process, and a resting for 8-12 minutes to drain.
- 5) A minimum interval is 6 hours and a maximum is 11 hours for the refrigerator, and 12 hours and 22 hours for the freezer, respectively.
- 6) When the system runs only for the refrigerator (R-Fan and COMP) and if the refrigerator can not reach the set.

Operation Function

9-6) Forced Operation function (Power cool key + Refrigerator Temp 8sec.)

- This function enables a pull-down mode, a defrost mode for the refrigerator only, a defrost mode refrigerator at the same time, and a cancellation of this function.
- Press Power Freeze and Refrigerator Temp. buttons for 8 seconds simultaneously to get in the ready mode for a forced operation.
- The display panel will return to normal after 15 seconds in the ready mode.
- At the ready mode, press any button once to start a pull-down operation, twice for a defrost cycle for the refrigerator, three times for a defrost cycle for the freezer and the refrigerator, and finally four times for cancellation of this function.
- Another way to cancel this function is to simply plug out and in the power cord.

1) Pull-down Operation

1-1) At the ready mode, press any button once then the buzzer will beep (ON for 1/2 second and OFF for 1/2 second) until this mode is cancelled.

1-2) At this pull-down mode, the compressor will start immediately (No 5 minute delay) and if the system is in the defrost cycle, it will be cancelled right away.

note) If this pull-down mode begins right after the compressor was off, the compressor may not start to run due to an overload condition.

1-3) At this mode, the compressor and freezer fan will operate continuously for 24 hours and the refrigerator fan will be on and off according to the set temperature(34°F)

1-4) After 24 hour operation, the system will be cycled at -14°F for the freezer and 34°F for the refrigerator.

1-5) In order to cancel this mode at any time, select the next mode on the ready mode or power off the system.

2) Defrost operation

2-1) At the pull-down mode, press any button again on the ready mode to begin the defrost cycle for the refrigerator.

2-2) The beep sound continues for 3 second at the beginning, then ON for 3/4 seconds and OFF for 1/4 second until this mode cease.

2-3) After this operation, the system will come back to normal operation.

2-4) At this mode, press any button again on the ready mode to operate the defrost cycles for both compartments.

2-5) The beep sound continues for 3 seconds at that time, then ON for 1/4 second and OFF for 3/4 seconds until the defrost operation cease.

3) Cancellation

3-1) At the R,F-Defrost mode, press any button again on the ready mode to return to a normal operation.

3-2) Simply unplug the power cord, then plug it again to return to a normal operation.

Operation Function

9-7) Power failure compensating function

- 1) When the freezer temperature is lower than 50°F, all functions on the display panel will be restored.
- 2) When the freezer temperature is higher than 50°F, all functions will be initialized.
(2°F for the freezer, 38°F for the refrigerator, and Cubed for the Ice Type)

9-8) Exhibition Function

- 1) This function is for a display purpose on the floor of show room or store.
 - 1) Mode ON/OFF
 - 1-1) For the exhibition mode, press Power Freeze and Freezer Temp. buttons simultaneously for 5 seconds until a “ding-dong” sounds.
 - 1-2) Press the same time buttons again for 5 seconds to cancel this mode put with a “ding-dong” sound.
 - 2) Operation
 - 2-1) Most of the system function except the compressor operation are working properly.
 - 2-2) There is no defrost cycle in this mode.

9-9) Self-Diagnostics function

- 1) Self-Diagnostics in the initial Power ON
 - 1-1) The control board performs a self diagnostics test within 1 second and check out the temperature sensors abilities.
 - 1-2) If a sensor failure occurs, a corresponding LED segment will blink.
 - 1-3) When a LED segment blinks, only the cancellation function (Press Power Freeze and Power Cool buttons simultaneously for 8 seconds) is acceptable.
 - 1-4) After a replacement of bad sensor or a cancellation of this function, this self diagnostics will end.
- 2) Self-Diagnostics in the normal operation
 - 2-1) To select this function, press Power Freeze and Power Cool buttons simultaneously for 5 seconds with an audible tone.
 - 2-2) In the self diagnostic mode, only corresponding LED segments will be illuminated (see the check list on)
 - 2-3) After a 30 second illumination of error signal, the system will return to the normal operation.

Operation Function

Table 1. Display table of self diagnosis.

No	Item	LED Display	Details	Remarks
1	R-sensor	REFRIGERATOR 5	<ul style="list-style-type: none"> • Connector contact failure • Short-circuit 	<ul style="list-style-type: none"> • Suspected to be below -58°F • Suspected to be over 150°F
2	R-defroster sensor	REFRIGERATOR d	<ul style="list-style-type: none"> • Connector contact failure • Short-circuit 	<ul style="list-style-type: none"> • Suspected to be below -58°F • Suspected to be over 150°F
3	Outer sensor	FREEZER E5	<ul style="list-style-type: none"> • Connector contact failure • Short-circuit 	<ul style="list-style-type: none"> • Suspected to be below -58°F • Suspected to be over 150°F
4	F-sensor	FREEZER F5	<ul style="list-style-type: none"> • Connector contact failure • Short-circuit 	<ul style="list-style-type: none"> • Suspected to be below -58°F • Suspected to be over 150°F
5	F-defroster sensor	FREEZER d5	<ul style="list-style-type: none"> • Connector contact failure • Short-circuit 	<ul style="list-style-type: none"> • Suspected to be below -58°F • Suspected to be over 150°F

9-10) Component Load Operation Function

- 1) In the normal operation, press Power Freeze and Power Cool buttons simultaneously for 3 second, then the display panel will blink for 2 seconds.
- 2) Press Refrigerator Temp. button to get into this check mode with an audible tone.
- 3) Each illuminating LED segment stands for the component which has an output signal from the control board.
- 4) This mode will terminate automatically after 30 seconds.

Operation Function

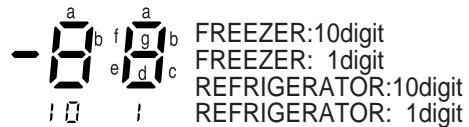
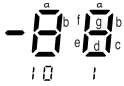

Table 2. Display table of the presently operating parts.

No	Content	Display LED	Operation	Remark
1	R-fan	a : REFRIGERATOR 1 digit	Include R-fan activation	Ref. 6.button scan and display circuitry 
2	R-defrost heater	c : REFRIGERATOR 1 digit	Defrost heater activation	
3	Initial start mode	d : REFRIGERATOR 1 digit	Initial power is activated ON	
4	Over load mode	e : REFRIGERATOR 1 digit	Outer temperature is over 95 °F	
5	Low temp.mode	f : REFRIGERATOR 1 digit	Outer temperature is below 68 °F	
6	Exhibition mode	g : REFRIGERATOR 1 digit	Exhibition mode is operated together	
7	Comp	a : FREEZER 1 digit	Led ON when COMP activation is included	
8	F-fan	b : FREEZER 1 digit	Led ON F-fan activation is included	
9	F-defrost heater	d : FREEZER 1 digit	Led ON when F-heater activation is included	
10	F-Lamp	a : FREEZER 10 digit	Led ON when F-lamp activation is included	
11	R-Lamp	b : FREEZER 10 digit	Led ON when R-lamp activation is included	

※ 3, 4, and 5 only explains the system operation states according to the ambient condition.

9-11) C-Fan Motor Delay Function of the Machine Compartment

- According to the ambient temperature, the condenser fan located in the machine compartment is operated with different modes.

	Ranges of ambient temp.	Operation
C-FAN Delay function	Above 66 °F	C-FAN is ON as soon as the compressor is on.
	61 °F ~ 65 °F	C-FAN is ON with 5 minutes delay from the compressor on.
	Below 60 °F	C-FAN is OFF regardless of the compressor operation.

13. Safety Instructions on Service

- Unplug the refrigerator before making any repair or any replacement.
 - ⇒ Avoid the electric shock.
- Use the rated components on the replacement.
 - ⇒ Check the correct model number, rated voltage, rated current, operating temperature and so on.
- On repair, be sure that the wires such as harness are bundled tightly and are not exposed by water.
 - ⇒ Bundle wires tightly in order not to be detached by the external force.
- On repair, remove completely dust, particles or other things on housing parts, harness parts, and connectors.
 - ⇒ Cleaning may prevent fire by tracking or short.
- Check if there is any trace indicating the infiltration of water on electrical parts.
 - ⇒ If there is a trace, change the related components or do the necessary action such as taping using the insulating tape.
- After repair, check the assembled state of parts.
 - ⇒ It must be the same assembled state as before.
- Check the surrounding conditions of the installed refrigerator.
 - ⇒ When the refrigerator is located at humid or wet place, or the installed state is unstable, change the location.
- If needed, do the ground.
 - ⇒ Especially, if there is a possibility of the electric leakage, this appliance must be properly grounded.
- Do not allow consumers to use one outlet for several plugs.
- Check if the power cord is placed under other appliance and so was damaged, worm-out and squeezed.
 - ⇒ Repair defective power plug or outlet immediately.
 - ⇒ Make sure that the power cord is not placed under other appliance or squeezed.
- Do not allow consumers to keep bottles or the likes in the Freezer or to keep foods in unstable position.
- Do not allow consumers to repair the appliance by themselves.
- Do not allow consumers to keep other chemicals except food.
 - ⇒ Medicines and other materials for research ; This appliance will not maintain the precisely constant temperature for them.
 - ⇒ Volatile material(Alcohol, Benzene, Ether, LP gas etc.) : possibility of explosion

Appendix I (Reference for circuit diagnostics)

Ref.1) Wire connector on the cabinet door.

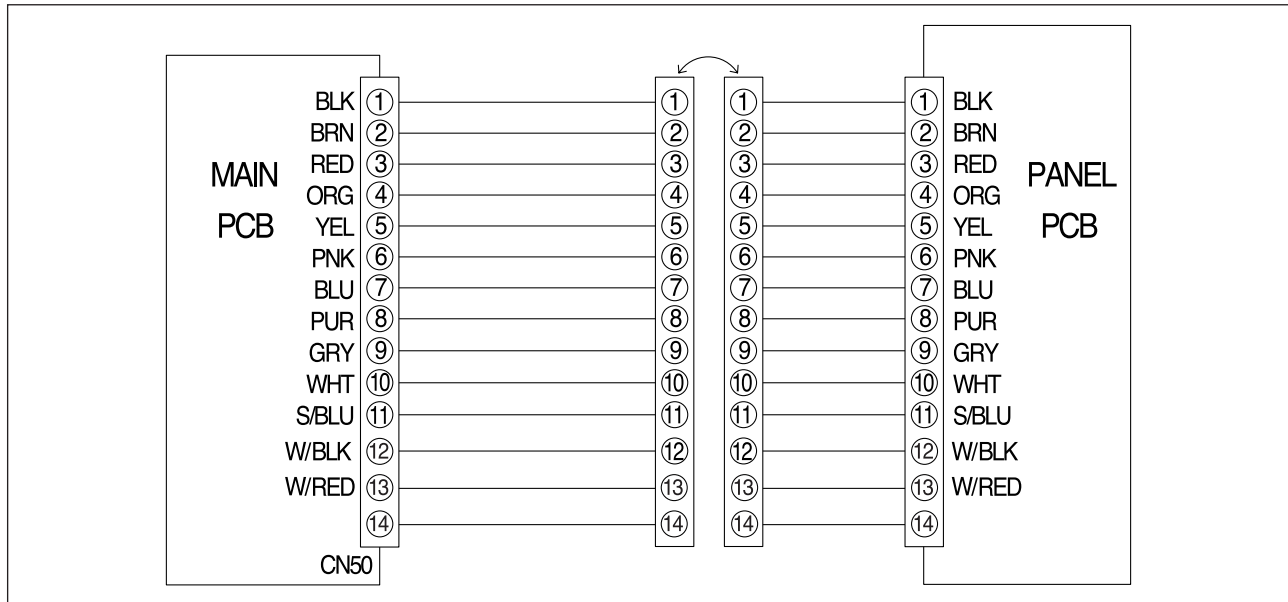

Ref. 2) How to check relay failure

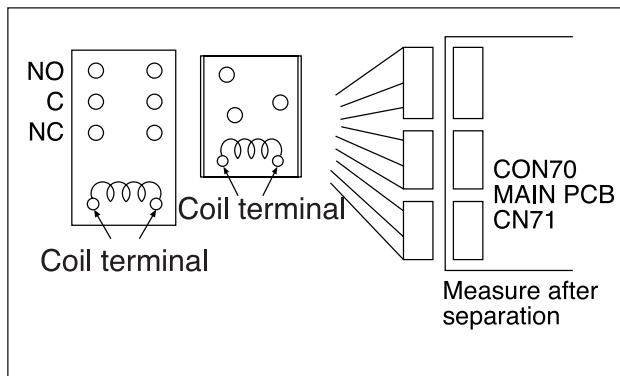

* Disconnect the wire connector from the main PCB CN70, 71 and measure the following items.

1. Measure the coil bisection of the relay and check whether it works.
2. Measure the apex bisection for open circuit.

Category	Voltage of coil terminal	Judge
3-contact terminal Relay	DC 12V(Operation)	C-NO:SHORT C-NC:OPEN
	DC 0V(Standstill)	C-NO:OPEN C-NO:SHORT
2-contact terminal Relay	DC 12V(Operation)	SHORT
	DC 0V(Standstill)	OPEN

Note) C → Common, NO → Normal open, NC → Normal close

3. When it operates as above, it is normal and when it does not operate, repair the corresponding relay.

Ref. 3) Check a load

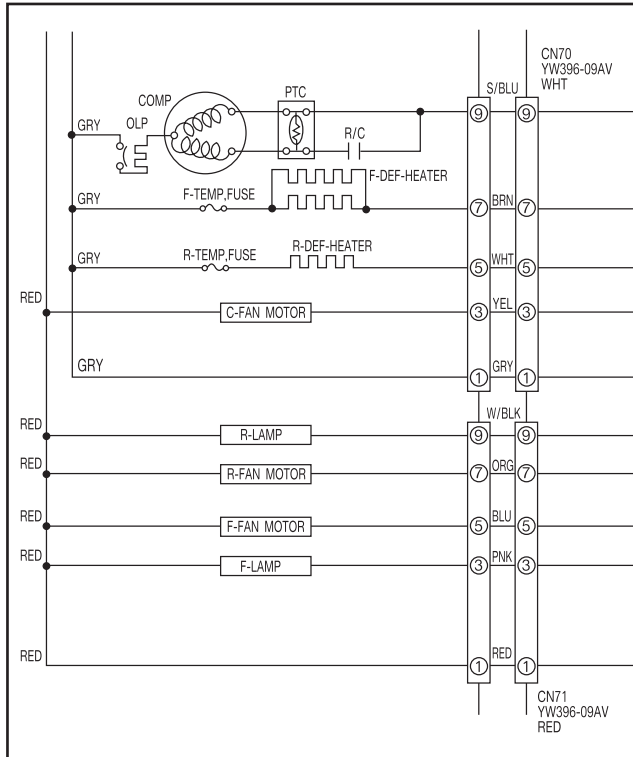

* Unplug the power cord and disconnect the connector from the main PCB CN70, 71 and measure the following:

1. Measure resistance between the terminals and check for malfunctioning of a load and wire connection.

Subordinate	Measurement terminal	Evaluation of measurement result
R Defrost heater	CN70 ⑤ - ①	
F Defrost heater	CN70 ⑦ - ①	
Comp	CN70 ⑨ - ①	
Comp-circulation fan	CN71 ⑦ - ①	
R-Circulation fan	CN71 ⑤ - ①	
F-Circulation fan	CN70 ③ - ①	
R-Lamp	CN71 ⑨ - ①	
F-Lamp	CN71 ③ - ①	

Ref. 4) Check sensors

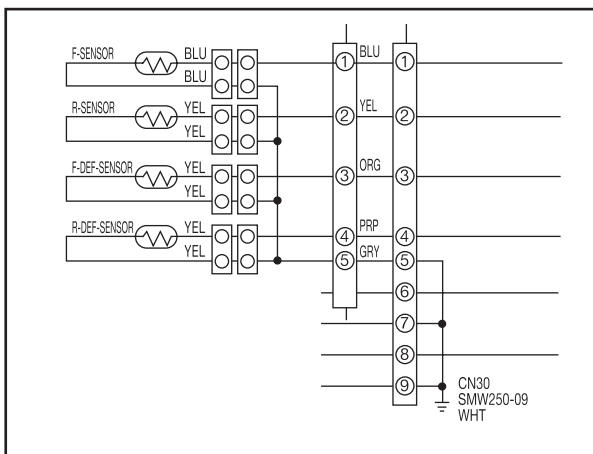

* Disconnect the connector from the main PCB CN30.

* Resistance will be lowered while the temperature rises due to a NTC type sensor.

1. R sensor measures resistance of CN30 between ② ~ ⑤.
2. Freezer sensor measures resistance of CN30 between ① ~ ⑤.

3. R-defrost sensor measures resistance of CN30 between ④ ~ ⑤.
4. F-defrost sensor measures resistance CN30 between ③ ~ ⑤.
5. The measured value above is compared to the sensor specification and the temperature table in specification found in the manual.

Ref. 5) Check Door S/W

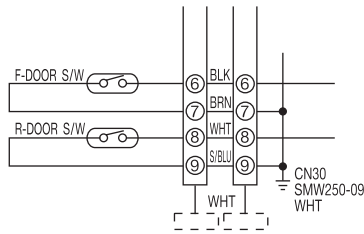

(Refrigerator Bulb)

1. Open the door and check if the freezer lamp turns on.
2. Press the Door S/W and check if the freezer lamp turns off.
3. Close the freezer door and repeat 1 and 2 for refrigerator door.
4. If there is a problem, check lightbulb and door S/W.
5. Check wire connection.

(Micom signal)

1. Check if CN30 ⑥ and ⑧ is 5V DC after closing the F-R doors.
2. Check if CN30 ⑥ is 0V DC when opening F door.
Check if CN30 ⑧ is 0V DC when opening R door.
3. If there is problem, check door S/W and wire connection.

Ref. 6) Forced Operation and Forced Defrosting

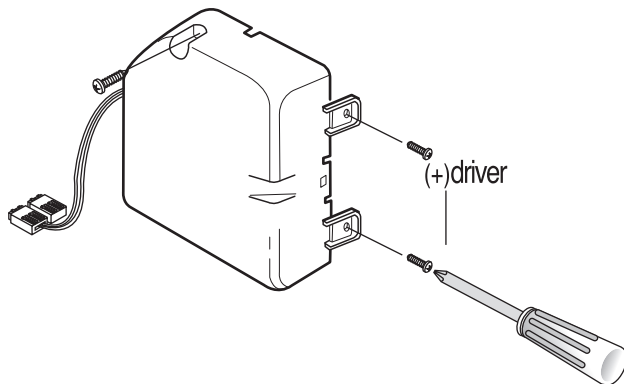

(Forced running)

* This function is used to turn on the comp and fan immediately regardless of the temperature of freezer using the test button on the main PCB.

1. Press the TEST button on the PCB after removing the main PCB cover in the machine compartment.
2. Buzzer will sound to indicate the forced running.

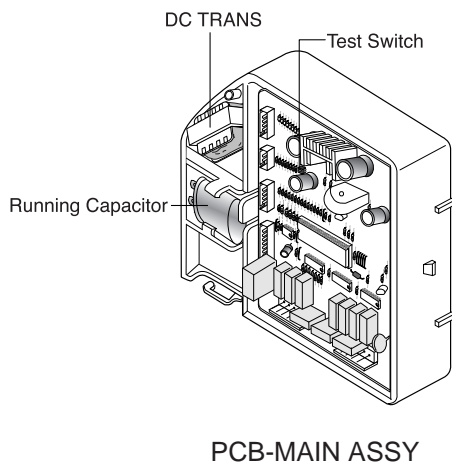

(Forced defrosting)

* This function is used to turn on the defrosting regardless of defrost time.

1. Press the button during forced running. Then, R-defrosting is performed.
2. If the button is press during R-defrosting, F-defrosting is also performed at the same time.
3. If the button is pressed during R-F defrosting, test mode is released.

11. PCB Circuit Diagram

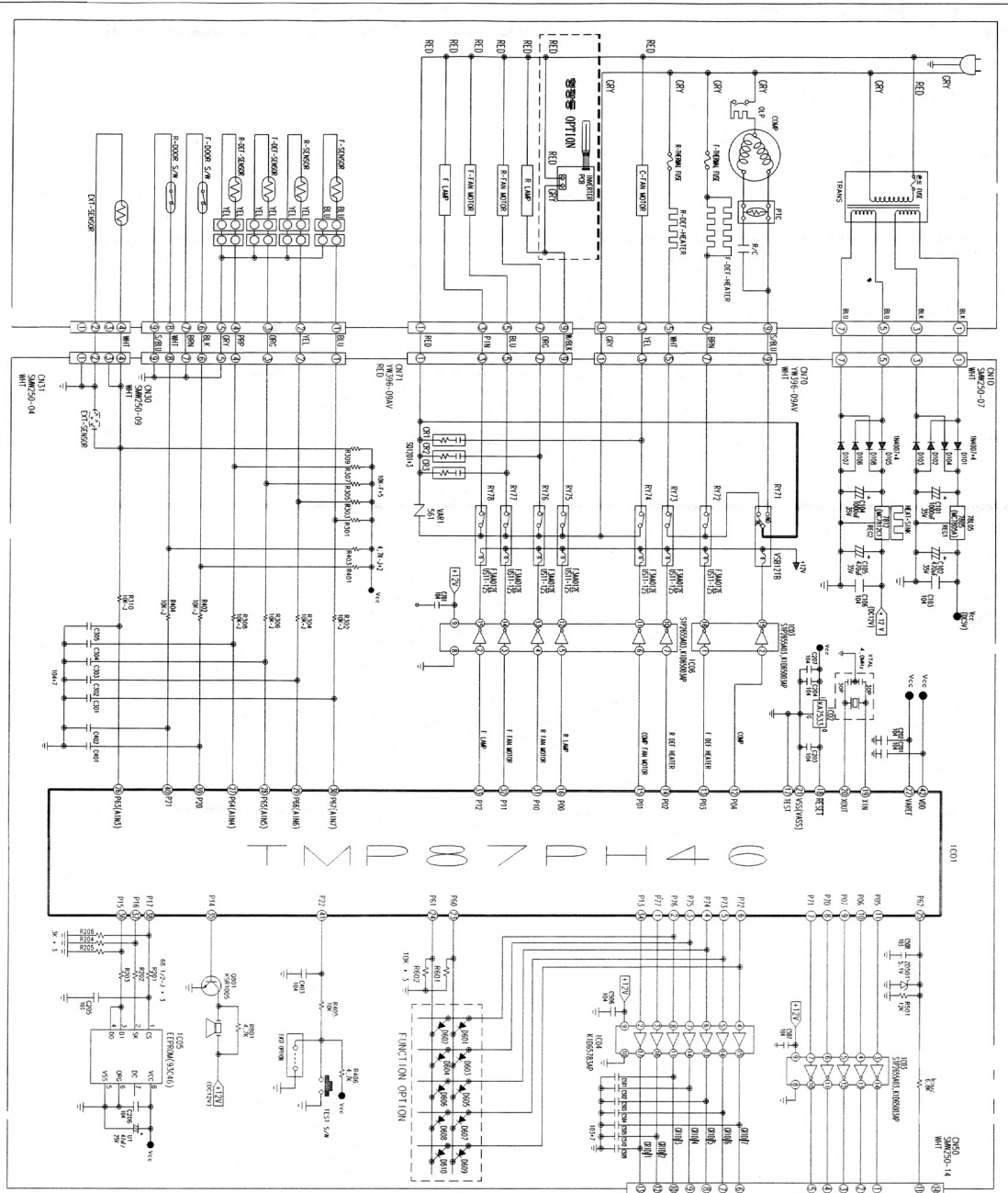

IC1: 74VHC04

IN	OUT
0	1
1	0
0	0
1	1

IC2: 74VHC00

IN1	IN2	OUT
0	0	1
0	1	1
1	0	1
1	1	0

IC3: 74VHC125

EN	IN	OUT
0	0	0
0	1	0
1	0	1
1	1	1

IC4: 74VHC126

EN	IN	OUT
0	0	0
0	1	0
1	0	0
1	1	1

IC5: 74VHC127

EN	IN	OUT
0	0	0
0	1	0
1	0	0
1	1	1

