



SAMSUNG

REFRIGERATOR

**RB215LASH
RB215LABP**

SERVICE Manual

REFRIGERATOR

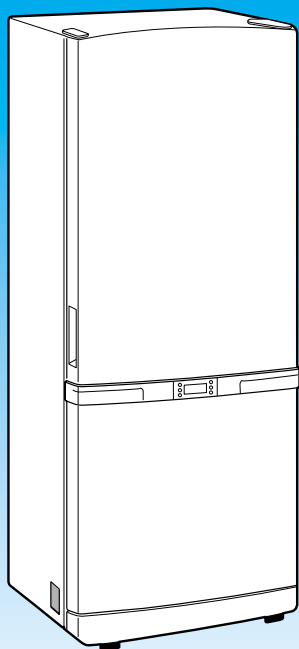

PRODUCT FEATURE

- Reversible Door
- Auto Ice-Maker
- Freezer Wire Box

SAM0075



WARNING

IMPORTANT SAFETY NOTICE

The service guide is for service men with adequate backgrounds of electrical, electronic, and mechanical experience. Any attempt to repair a major appliance may result in personal injury and property damage. The manufacturer or dealer cannot be responsible for the interpretation of this information.

SAMSUNG ELECTRONICS AMERICA, INC.

Technical Service Guide

Copyright ©2005

All rights reserved. This service guide may not be reproduced in whole or in part in any form without written permission from the SAMSUNG ELECTRONICS Company.

Contents

1. INSTALLATION	4
2. NOMENCLATURE	4
3. PRODUCT SPECIFICATIONS	5
4. ELECTRICAL PART SPECIFICATIONS & STANDARD	5
5. INTERIOR VIEWS AND DIMENSIONS	7
6. REFRIGERATION CYCLE AND COOL AIR CIRCULATION ROUTE	9
7. MECHANICAL DISASSEMBLY	11
8. REVERSIBLE THE DOOR SWING	18
9. INSTALLATION OF THE WATER LINE	23
10. TEMP CONTROL & OPERATION FUNCTIONS	25
11. OPERATION PRINCIPLES BY PARTS OF CIRCUIT	46
12. DIAGNOSTICS	54
13. ILLUSTRATED PARTS CATALOG	71
14. REFERENCE	76
15. PCB DIAGRAM	79
16. CONNECTOR ARRANGEMENT & DESCRIPTIONS	80
17. BLOCK DIAGRAM	81
18. CIRCUIT DIAGRAM	82
19. WIRING SCHEMATIC	83
20. TEMP TO RESISTANCE OF SENSOR & MICOM PORT VOLTAGE	84

1. INSTALLATION



- 1) **To protect refrigerator in movement**
Use padded hand truck from side only.
- 2) **Remove all protective tape and pad from the fridge.**
Connect power cord. Adjust the clearance between the doors.
- 3) **Temperature controls and preset in the factory for recommended settings.**
The refrigerator should runs smoothly and lower the temperature gradually.
- 4) **Once the refrigerator temperature is sufficiently low**
It is recommended to store foods in the refrigerator.
It takes a few hours to reach the preset temperatures.

2. NOMENCLATURE

2005 Models

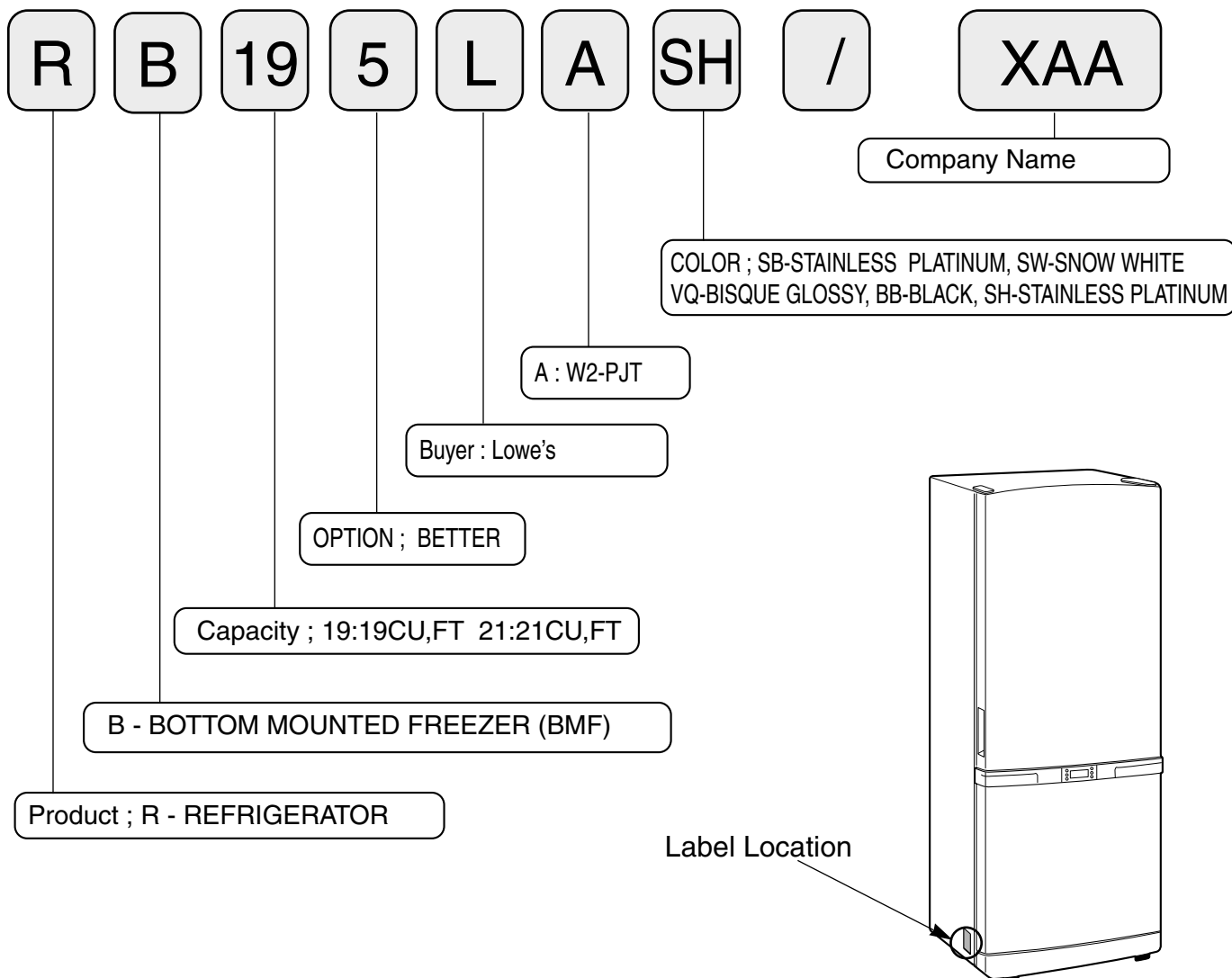

3. PRODUCT SPECIFICATIONS

Model		RB215LASH, RB215LABP
Type		BMF 2 Door
Temperature control		Electronic control
Net Capacity (ft ³)	Total	20.4
	Freezer	6.5
	Fridge	13.9
Net dimension (W x D x H)		32.3 x 28.3 x 69.9
Foam	Cabinet insulation	CYCLO-PENTANE
	Door insulation	CYCLO-PENTANE
Liner	Cabinet	A.B.S
	Door	A.B.S
Net weight(lb)		241

4. ELECTRICAL PART SPECIFICATIONS & STANDARD

ITEM		STANDARD
Model		RB215LASH, RB215LABP
Rated Voltage		115V
Frequency		60HZ
Compressor	Model	MK172C-L2U
	Starting type	RSCR
	Refrigerant	R134a
	Oil Charge	Freol α-10c(Ester), 265cc
Evaporator	Freezer	Split Fin & Tube Type
	Fridge	Split Fin & Tube Type
Condenser		Forced & Natural Convection Type
Dryer		Molecular Sieve XH-9
Capillary tube		ID0.82 x L3000
Earth screw		BSBN(Brass screw)
Door switch		AC125V 1.4A(SSD-6D)

ELECTRICAL PART SPECIFICATIONS & STANDARD

ITEM			STANDARD			
Temperature	Freezer	Type	Temperature Selection	ON(°F)	OFF(°F)	
		F-Sensor	-14°F	-12.0°F	-16.0°F	
			-2°F	0°F	-4°F	
			8°F	10°F	6°F	
	Fridge	Type	Temperature Selection	ON(°F)	OFF(°F)	
		R-Sensor	34°F	36°F	32°F	
38°F			40°F	36°F		
		46°F	48°F	44°F		
Electrical parts	Defrosting	First Defrost Cycle (Concurrent Defrost of F and R)		4hr ±10min		
		Defrost Cycle(FRE)		Min. 12hrs, Max. 22Hrs		
		Defrost Cycle(REF)		Min. 6hrs, Max. 11Hrs		
		Pause Time		10 ±2min		
	Sensor	Freezer-Sensor		THERMISTOR (502AT), SPEC:5.0KΩ AT 77°F		
		Fridge-Sensor				
		FRE Evap-Sensor				
		REF Evap-Sensor				
		Ambient TEMP-Sensor				
	Heater	Defrost Heater(FRE)		242W		
		Drain Heater(FRE)		52W		
		Defrost Heater(REF)		120W		
		Drain Heater(REF)		38W		
		Ice-maker Heater		10W		
	Fuse	Thermal-Fuse for preventing overheating of Freezer Defrost-Heater		AC250V 10A 170.6±9°F		
		Thermal-Fuse for preventing overheating of Freezer Defrost-Heater				
	Capacitor	RUNNING	250VAC, 12μF			
	Over-Load Protector	MODEL	4TM437RHBYY-53			
TEMP. ON		156 ± 16°F				
TEMP. OFF		266 ± 9°F				
STARTING- RELAY	MODEL	J531Q33E100M200-2				
	INITIAL RESISTANCE	10 ± 20 Ω				
MOTOR-FAN	FRE.	IS3210-SNP6D				
	REF.	IS3208-SNP6H				
	CIRCUIT	IS3208-SCH6A				
LAMP	FRE(INCANDESCENT)	110V-130V/15W X2				
	REF(INCANDESCENT)	110V-130V/30W				

5. Interior Views and Dimensions

5-1) Shelves and Bins

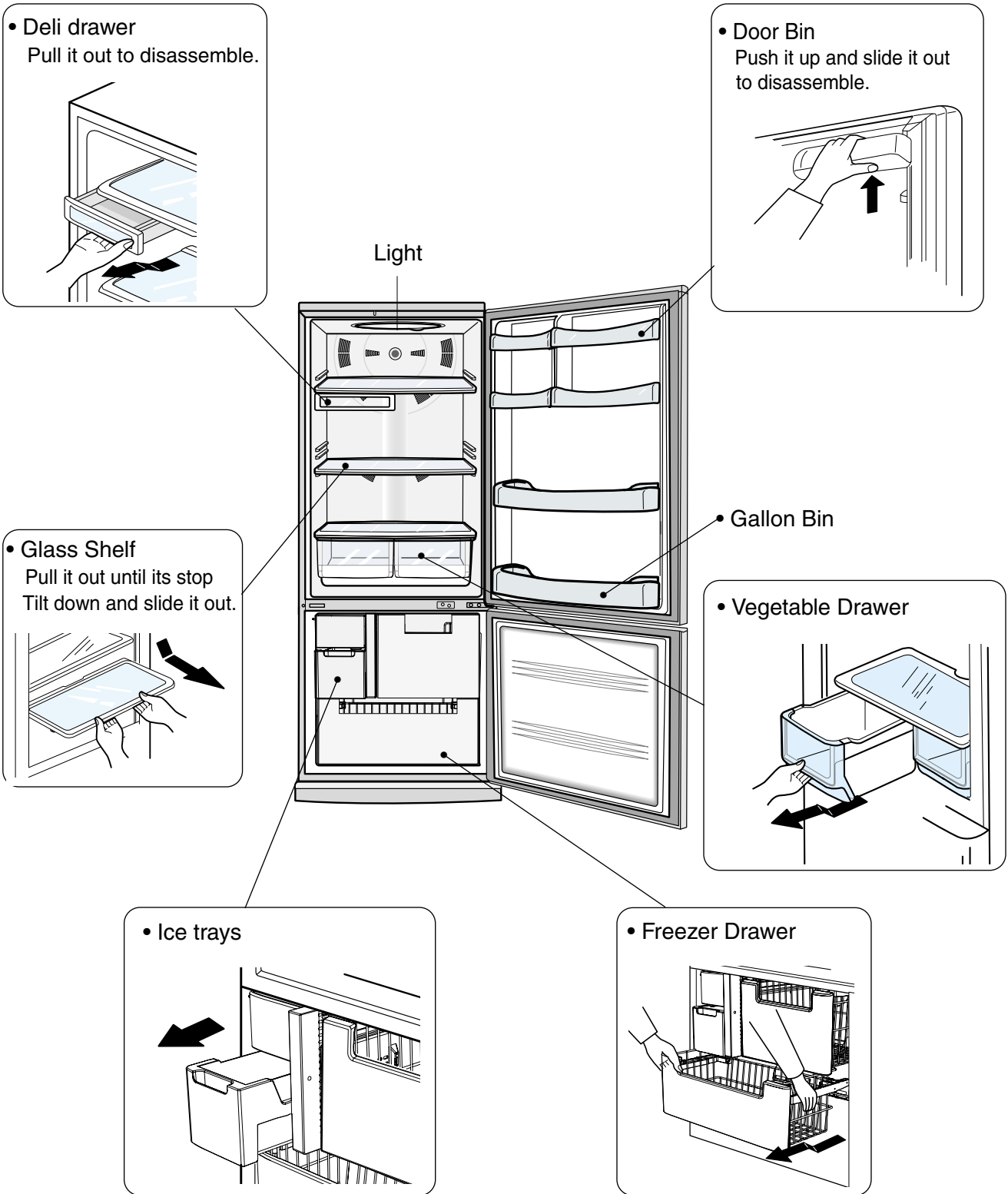

Interior Views and Dimensions

5-2) Dimensions of Fridge (Inches)

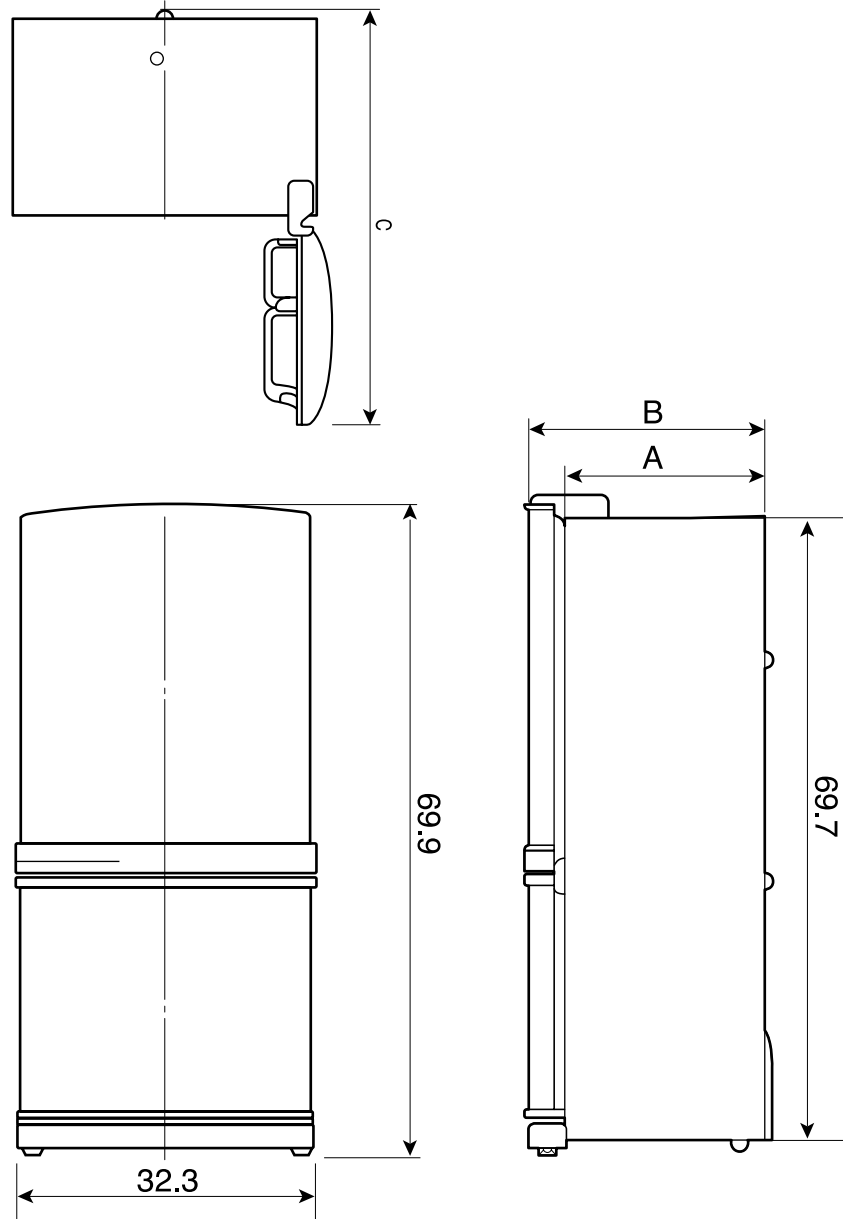

MODEL	A	B	C
RB215	26.3	30.3	59.8

6. Refrigeration Cycle and Cool Air Circulation Route

6-1) Refrigerant Route in Refrigeration cycle

Compressor → Sub condenser → Cluster pipe → Hot pipe → Dryer → Capillary tube → R-Evaporator → F-Evaporator → Accumulator → Suction pipe → Compressor

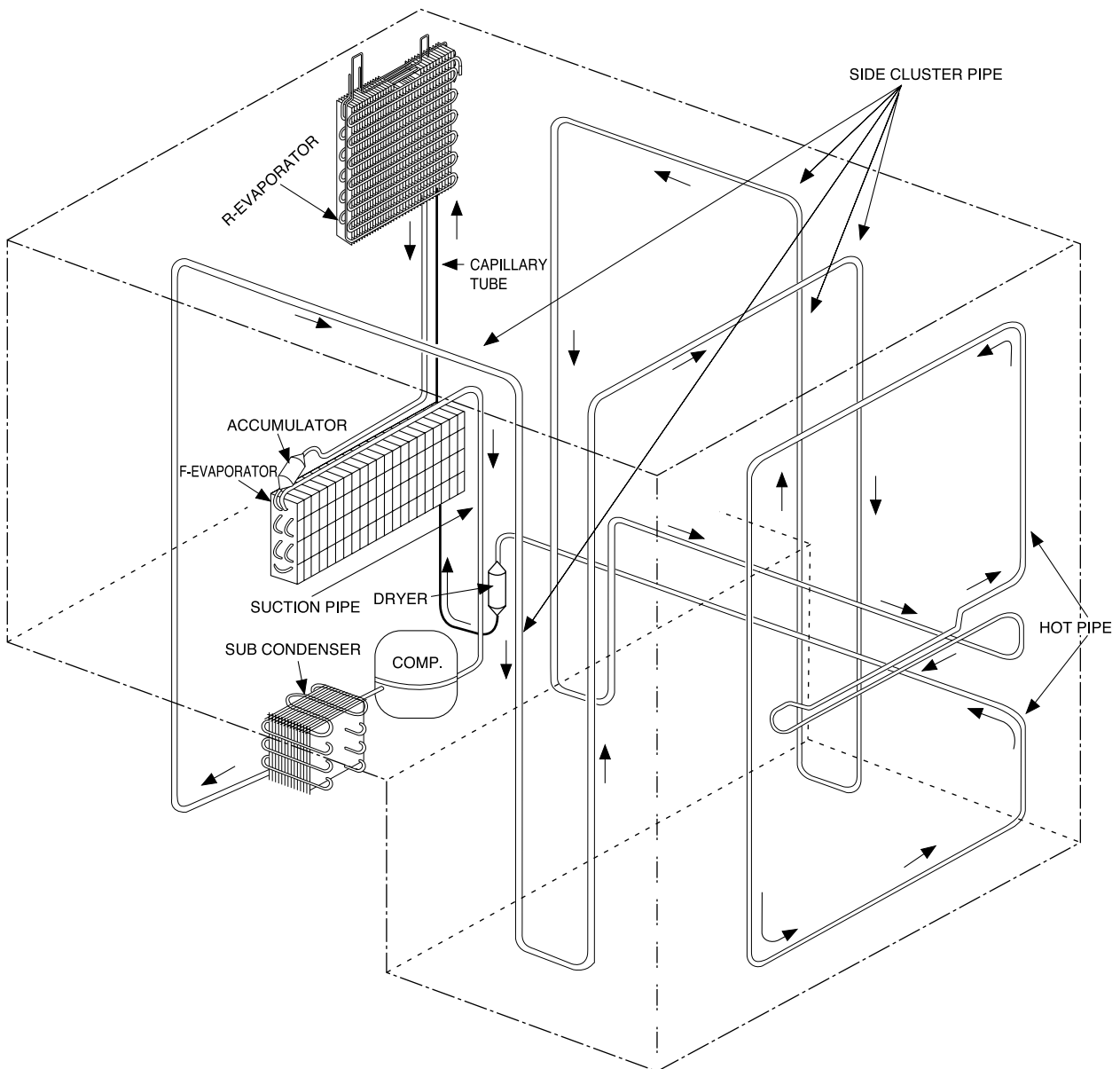

Refrigeration Cycle and Cool Air Circulation Route

6-2) Cool Air Circulation

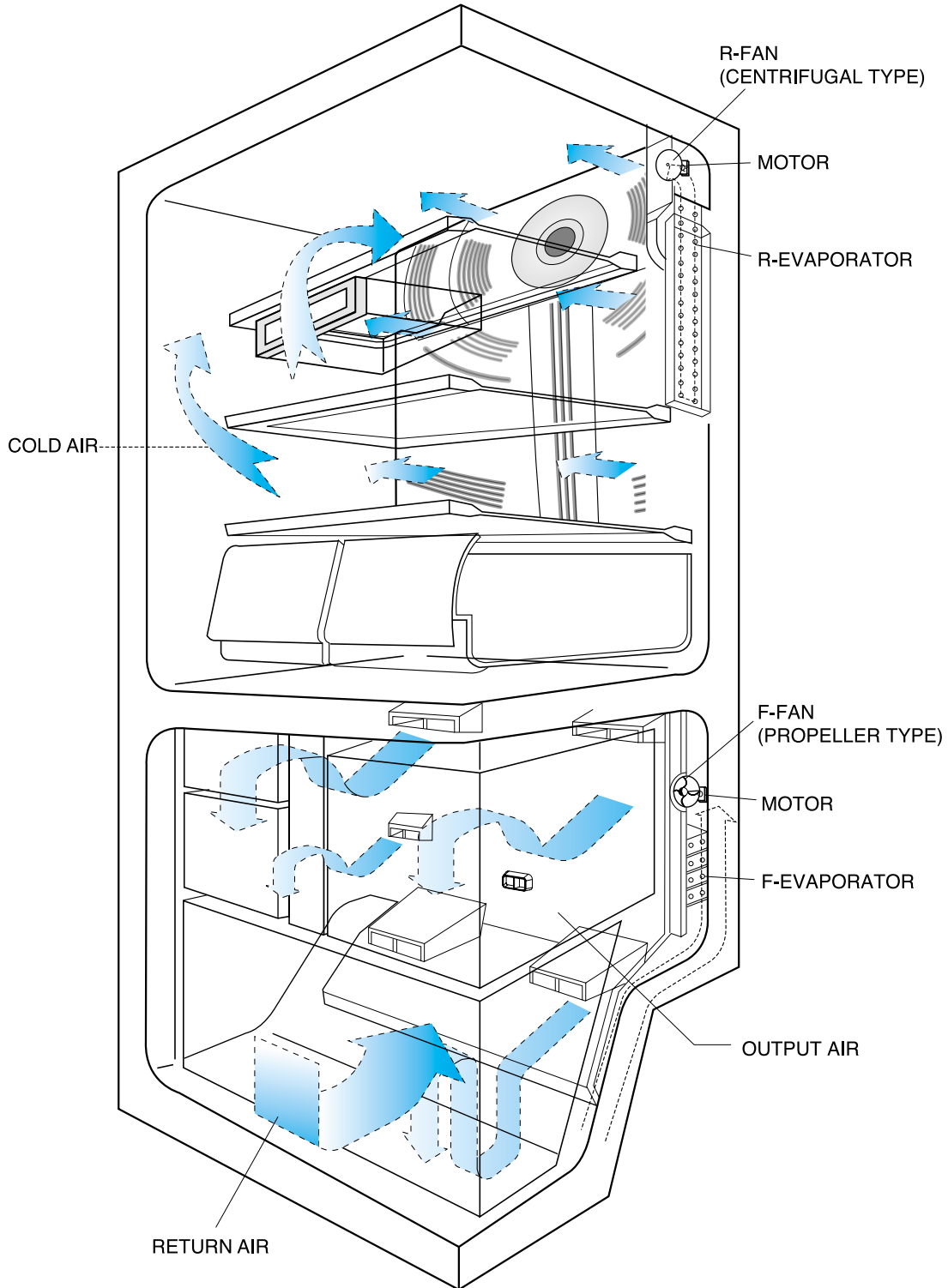

7. Mechanical Disassembly

Fridge Disassembly

Control Panel	12
Fridge Light	13
Freezer Light	13
Evaporator Cover in the Fridge	14
Evaporator Cover in the Freezer	15
Evaporator in the Freezer	16
Evaporator in the Fridge	16
Machine Compartment & Electric Box	17

Mechanical Disassembly

Control Panel

1. Remove the screws.
2. Pull out the control panel.
3. Disconnect the wire connector.

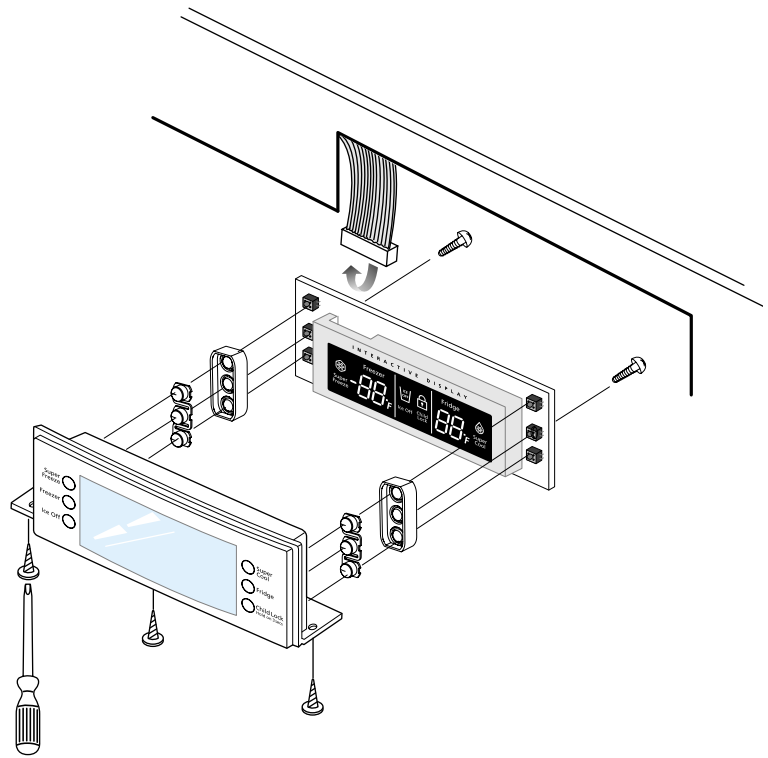

Mechanical Disassembly



Warning

Always unplug the power cord before replacing the fridge lamp. There is the danger of electric shock.

Fridge Light

1. Remove the screw.



2. Remove the lamp cover by unlocking the tabs and pulling the cover down.



3. Replace the lightbulb by turning it counter-clockwise.



4. After replacing the bulb, reattach the cover and screw it again.
5. Plug the power cord in and check the lamp by pressing the R-door switch.

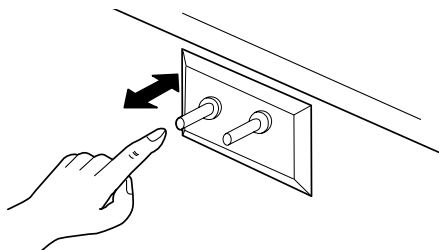

Freezer Light

1. Remove the cover by pressing the bottom tab.



2. Replace the two bulb by turning it counter-clock wise.



3. Reattach the cover and check the lamp by pressing door switch.

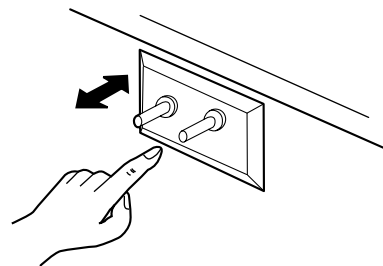

Mechanical Disassembly

Evaporator Cover in the Fridge

1. Remove all shelves and drawers from the fridge.

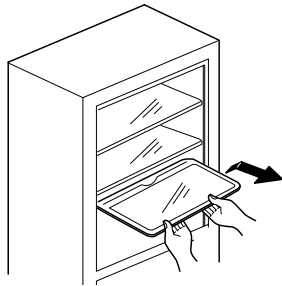

2. Pull out the screw caps with a small flat-blade screwdriver.
3. Remove 6 Phillips screws from the cover.

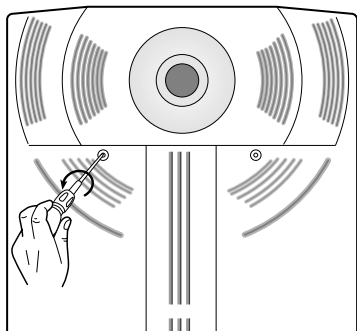

4. Unlock the 2 tabs with a flat-blade screwdriver on each side of the bottom cover.
5. Remove the evaporator cover by pulling out from the bottom of the evaporator cover.

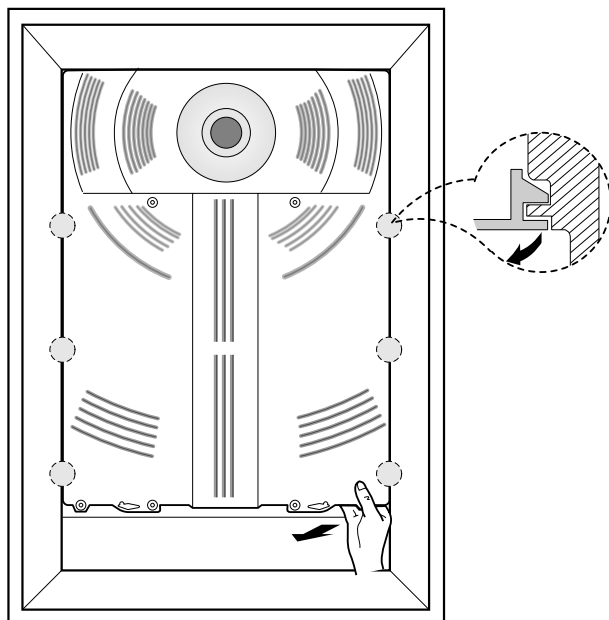

6. Disconnect the wire connector.

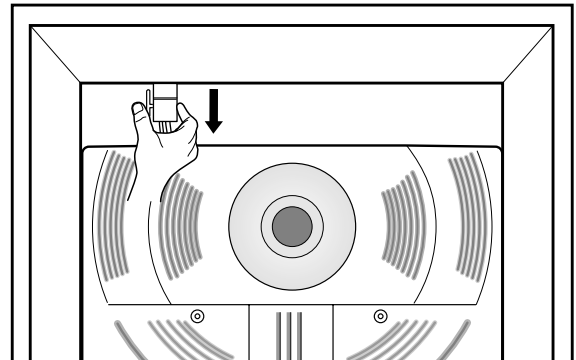

- Ductwork of the evaporator fan assembly.

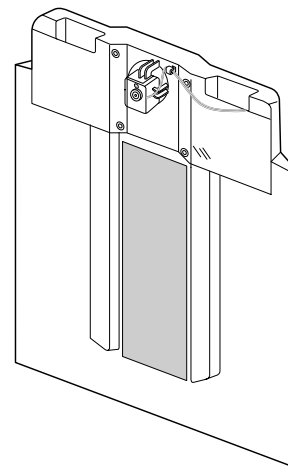

Mechanical Disassembly

Evaporator Cover in Freezer

1. Remove all drawers from the freezer.

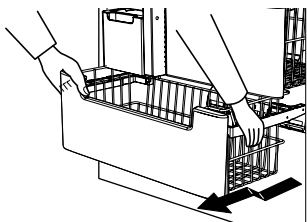

2. Remove screws (2) from the support rail.

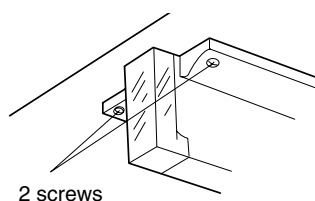

3. Pull down the holder of the support rail and disconnect the wire connector to remove it.

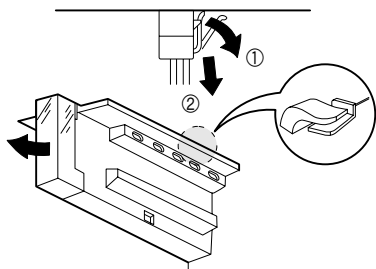

4. Unlock the tabs around the evaporator cover from the bottom.

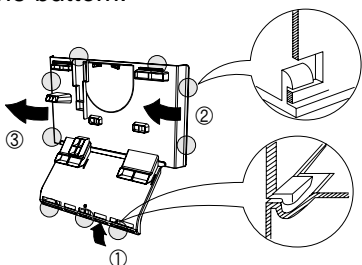

5. Disconnect wire connector from the top-left corner.

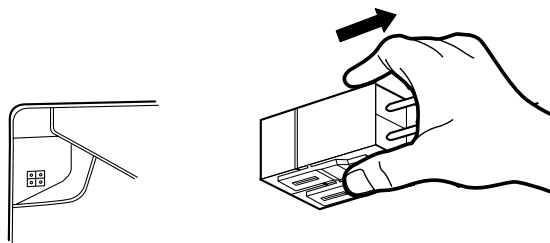

6. Remove 2 screws from the rear cover of the freezer evaporator and unlock the tabs to remove it.

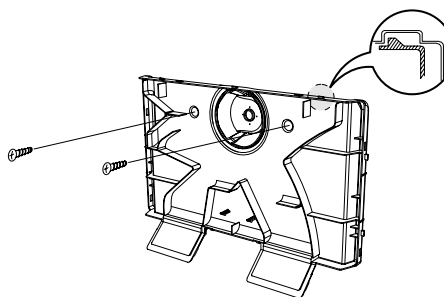

Mechanical Disassembly

Evaporator in Fridge

Evaporator is located in the bottom of fridge.

1. Take off the ductwork in fridge.
2. Disconnect the wire connector.(Heater and Thermistor)
3. Desolder the capillary tube and the suction line from the evaporator.
4. Remove the evaporator.
5. With a file, score the capillary tube just upstream of the soldered point. Break off the soldered section to help prevent solder from plugging the tube during soldering.
6. Place a new evaporator and braze the suction and capillary tube to evaporator using silver solder.
7. Install a replacement dryer.
8. Evacuate and recharge the system using reasonable procedures.

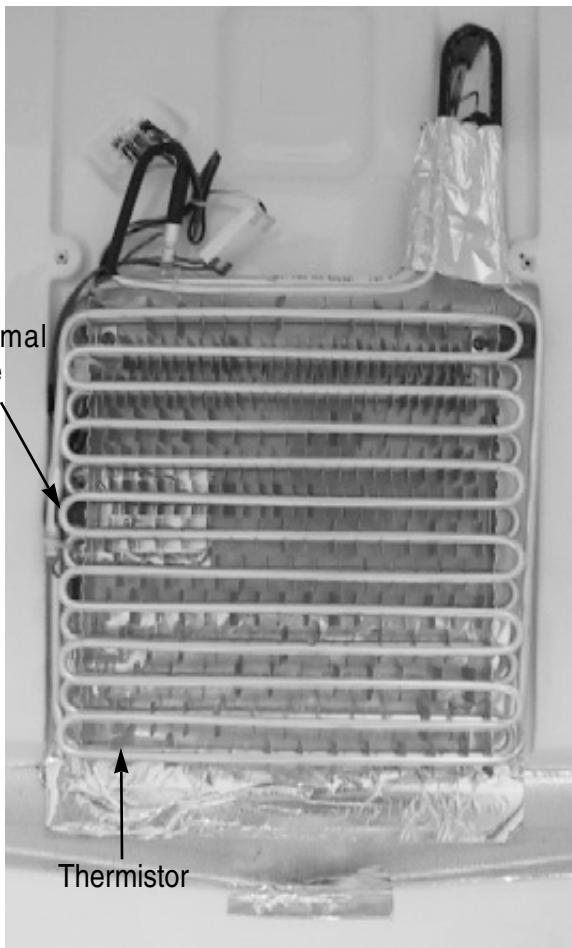

Evaporator in Freezer

Evaporator is located in the bottom of freezer to produce cold air driven across the evaporator coils.

1. Take off the ductwork in Freezer.
2. Disconnect the wire connector (Heater, Bimetal, and Thermistor).
3. Desolder the inlet and outlet tubes.
4. Remove the evaporator.
5. Take the same steps to seal the system as mentioned earlier.

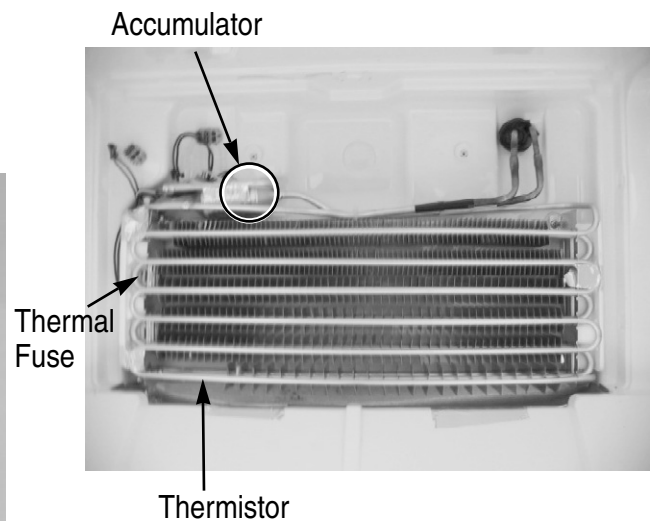

Mechanical Disassembly

Machine Compartment & Electric Box



Warning

Make sure the power cord is unplugged before replacing any electric components.

1. Unplug the power cord.

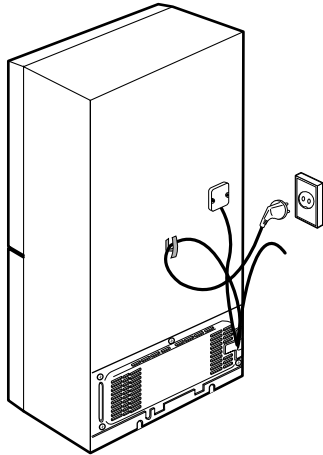

2. Remove the screws of the compartment cover. Slide it up and take out from the fridge.

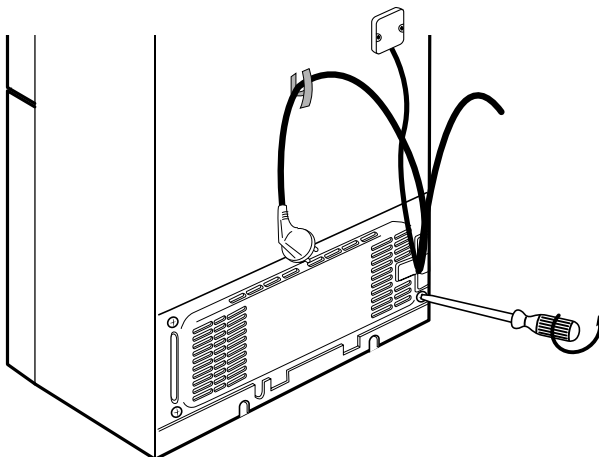

3. Machine compartment assembly

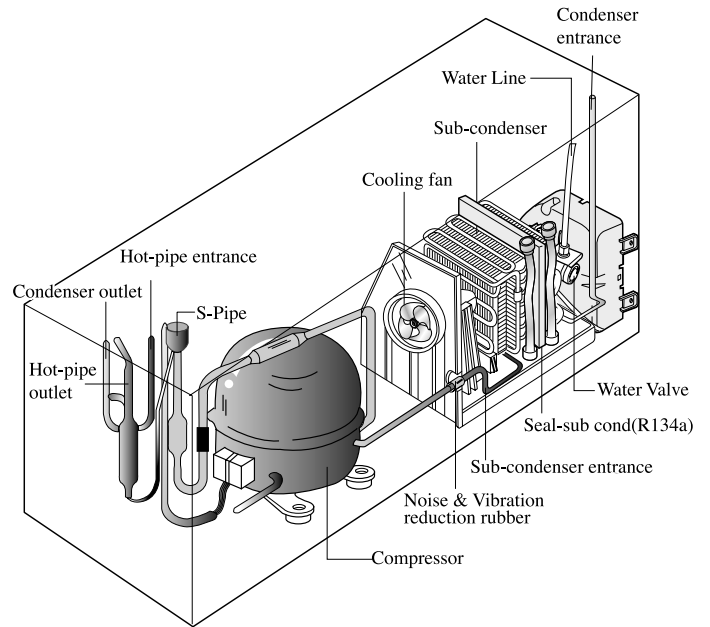

4. Disassemble the electric box cover after removing the screws with a Phillips screwdriver.

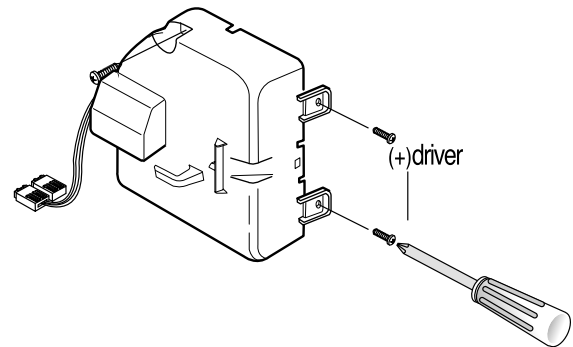

5. Electric box assembly

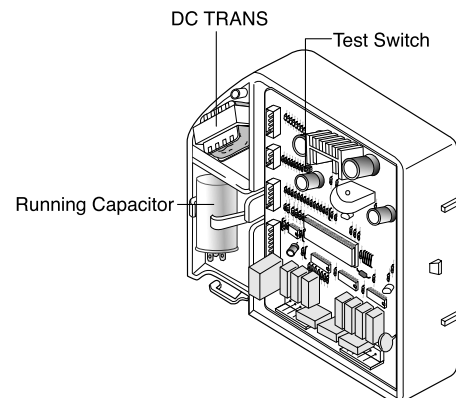

8. REVERSING THE DOOR SWING Read these instructions completely and carefully

- IMPORTANT NOTES



Warning

Unplug the fridge from its electrical outlet.
Empty all door guards / racks.

1. If you want to change the door direction.
2. Read the instructions carefully before starting.
3. Handle parts carefully to avoid scratching paint.
4. Set screws down by their related parts to avoid using them in the wrong places.
5. Provide a non-scratching work surface for the doors. (ex : blanket)
6. During door reversing, fridge should not be stained with oil.

- TOOLS YOU WILL NEED



screwdriver



10 inch wrench

- ADDITIONAL PARTS

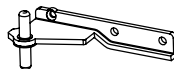

Hinge Mid



Screw



Compression Fitting



Compression Nut

- DISASSEMBLY THE FRIDGE DOOR

1. After removing the screw, disassemble the Upper Right Cover Hinge.



2. Disconnect electric wire on the top of the fridge.



3. With the 10 inch wrench, remove the four bolts that hold the top of the fridge.



4. Apart Hinge from electric wire as below picture.



REVERSING THE DOOR SWING

Read these instructions completely and carefully

5. Disassemble the fridge door by lifting it upward.
Be careful not to drop and scratch the fridge door.

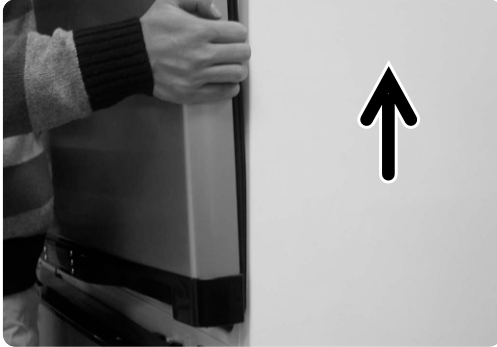

- ASSEMBLY OF FREEZER DOOR

8. After removing the screw, disassemble the Cover Hinge(left) and the Hinge(right).

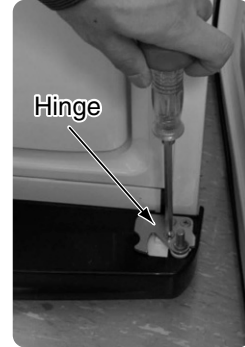

- DISASSEMBLY OF FREEZER DOOR

6. After removing the screw and two bolts, disassemble Hinge Mid.



9. Move the hardware found on the right side of the cabinet to the left and vice-versa.

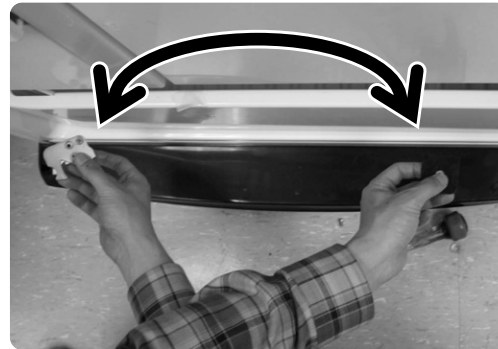

7. Disassemble the Freezer Door by lifting it upward.
Be careful not to drop and scratch the Freezer door.



10. After removing the left and right side screws, disassemble the Grommet, Stopper Door and Stopper-Mid of the right bottom of freezer-door.



REVERSING THE DOOR SWING

Read these instructions completely and carefully

11. Move the hardware found on the right side of the door to the left and vice-versa.

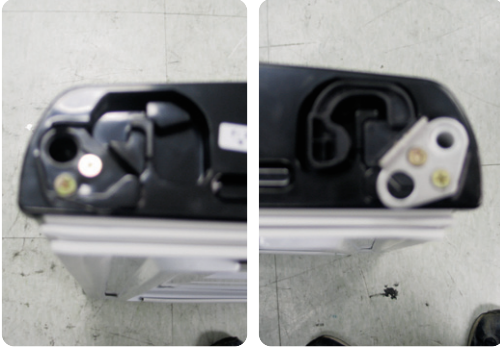

12. Disassemble the Door S/W with tools. Be careful not to scratch.



13. Disassemble the Cap Door S/W, Sleeve and the screws.

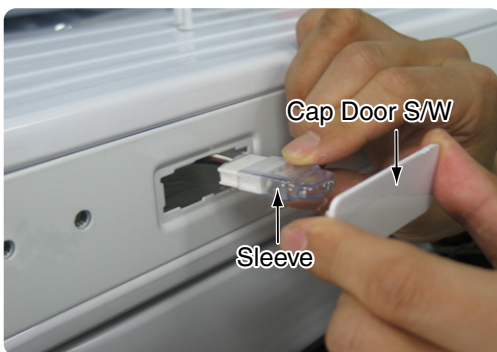

14. Re-install parts in their opposing sides. Assemble the Door S/W as it is. (Make sure not to insert it upside down)



15. Assemble Freezer Door by fitting the lower hinge into the hinge grommet hole. Don't forget to insert washer with grease.



16. Fix the additional Hinge mid into the door hole.

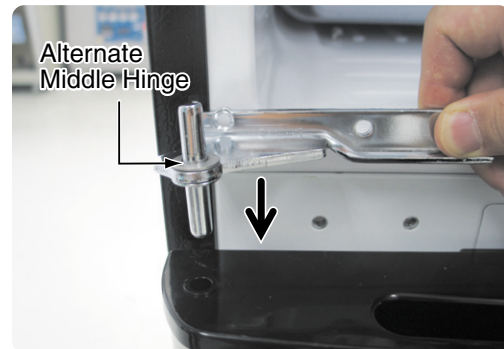

REVERSING THE DOOR SWING Read these instructions completely and carefully

17. Reinstall the middle hinge on the left side of the cabinet. (Use the alternative hinge supplied) Don't forget to insert washer with grease.



20. Move the hardware from left side of door to the right side and vice-versa.

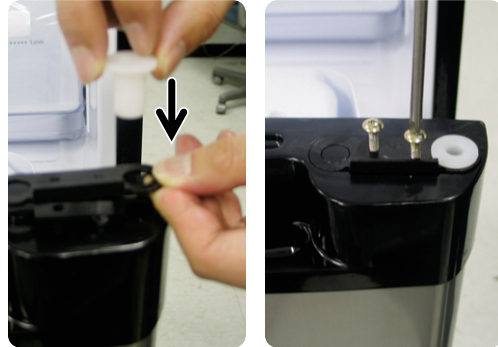

18. Confirm opening and closing of the door.



21. Fit the fridge door into the middle hinge.



- ASSEMBLY OF FRIDGE DOOR

19. After removing the screws, disassemble the Stopper Door and Grommet.



22. After removing the screw, disassemble the Cover-Cap Door and Cover Hinge.

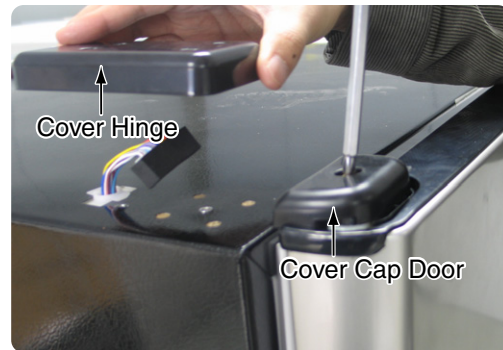

REVERSING THE DOOR SWING Read these instructions completely and carefully

23. Place the Grommet and Cap wire taken from the left connector on the right connector.

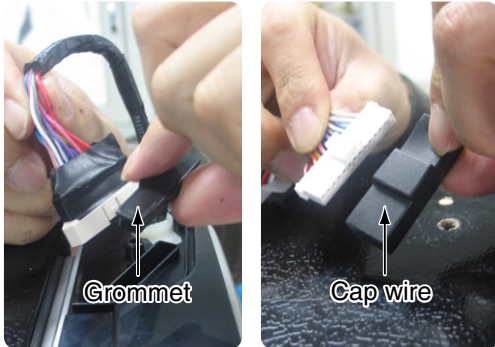

24. Re-install parts in their opposing sides. Electric wires must be sealed in covers.



25. After securing the top hinge with the screws, connect the electric wire.



26. Assemble the Cover Hinge with the screws.

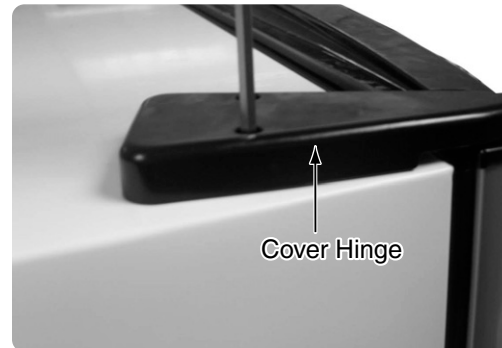

27. Finally, confirm opening and closing of the fridge door.



28. Make any necessary adjustments to insure proper sealing of the doors.

9. INSTALLATION OF THE WATER LINE

9-1) Before You Install the water line

- This water line installation is not warranted by the fridge or icemaker manufacturer. Follow these instructions carefully to minimize the risk of expensive water damage.
- Banging pipes (water banging in the pipes) in house plumbing can cause damage to fridge parts and lead to water leakage or flooding. Call a qualified plumber to correct the problem before installing the water supply line to the fridge.
- To prevent burns and product damage, do not hook up the water line to the hot water line.
- Do not install the icemaker tubing in areas where temperatures fall below freezing.
- When using any electrical device (such as a power drill) during installation, be sure the device is insulated or wired in a manner to prevent electric shock.
- All installations must be in accordance with local plumbing code requirements.



NOTE

- Water line Kit and water filter are not covered by Samsung Warranty and manufacturer (or dealer, installer) of them should be responsible for the defect and all the loss caused by water filter & water line kit.
- Filter should be replaced according to manufacturer (or dealer)'s instruction.
- To order additional water filters, please contact the manufacturer (or dealer) of the filter.

- For using the water filter

9-2) Connecting to water supply line

- Shut off the main water supply line and turn the Ice maker to the off position.
- Locate the nearest cold drinking water line.
- Follow the instructions in the ice maker installation kit.
- After connecting the water supply line with Cartridge Holder inlet and installing the Filter Cartridge (insert plastic line to the case water filter inlet until you feel its limit).
- Turn on water supply and flush 4 or more gallon into a bucket to clear the water filter.

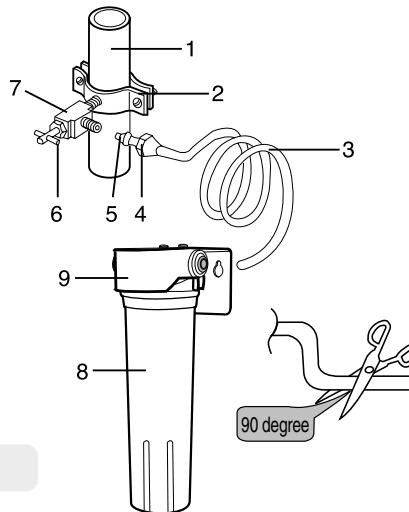

1. Cold Water line
2. Pipe Clamp.
3. Plastic line
4. Compression Nut
5. Compression Sleeve
6. Shut Off Valve
7. Packing Nut.
8. Filter Cartridge
9. Cartridge Holder



NOTE

- Do not use copper line.

INSTALLATION OF THE WATER LINE

9-3) Connect the water line to the fridge

- Connect the plastic line on the back of your fridge to the outlet of cartridge holder (insert plastic line to the cartridge holder outlet until its limit)
- Insert plastic clip to the cartridge holder inlet and outlet.
- Turn water on and check for any leakage.

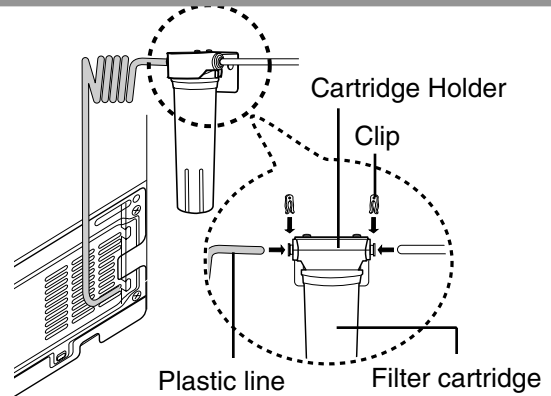

NOTE

- You can purchase the necessary filter cartridge at your nearest Lowe's, make sure you buy SAMSUNG filter cartridge (Replacement cartridge No : DA29-00015A) to ensure its performance.
- Waterline must be connected to drinkable water only

9-4) Connecting to water supply line

- Shut off the main water supply line and turn the Ice maker to the off position.
- Locate the nearest cold drinking water line.
- Follow the instructions in the ice maker installation kit.

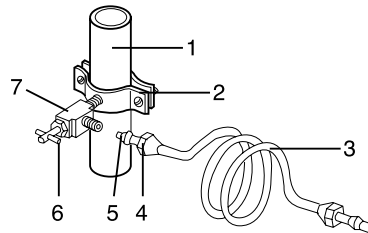

1. Cold Water line
2. Pipe Clamp.
3. Copper (or Plastic) line
4. Compression Nut
5. Compression Sleeve
6. Shut Off Valve
7. Packing Nut.

9-5) Connect the water line to the fridge

- Slip the compression nut through the plastic tube.
- After inserting the compression nut into plastic tube, tighten the compression nut onto 1/4" compression fitting(union).

NOTE

Do not overtighten the compression nut.

- Slip the compression ferrule and nut on copper(or plastic) tubing as shown.
- After inserting the sleeve, tighten the compression nut onto the compression fitting(union).
- Turn water on and check for any leakage.

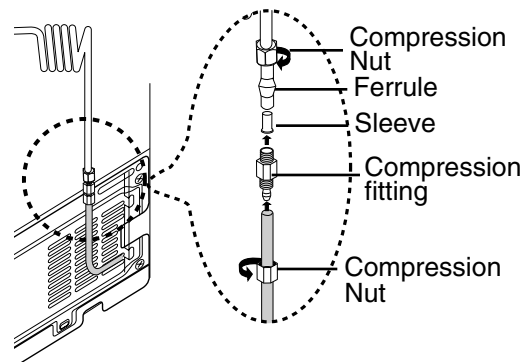

NOTE

- You can purchase the necessary filter cartridge at your nearest Lowe's, make sure you buy SAMSUNG filter cartridge (Replacement cartridge No : DA29-00015A) to ensure its performance.
- Waterline must be connected to drinkable water only
- Compression fitting and nut will be given inside of ice bucket.

10. Temp Control & Operation Functions

10-1) DISPLAY DESIGN	26
10-2) Temp Control Function	26
10-3) Super Freeze Function and Super Cool Functions	27
10-4) Ice Off Function	29
10-5) Child Lock Function	29
10-6) Buzzer Alarm Function	30
10-7) Machine Compartment F-Fan Motor Delay Function	30
10-8) Ice Maker Function (Only applicable to Model with the Auto Ice Maker function)	31
10-9) Defrost Function	35
10-10) Test Function	35
10-10) Function when the power is applied for the first time.	36
10-12) Power Compensation Function	37
10-13) Self Diagnosis Function	37
10-14) Power Compensation Function	40
10-15) Option Setting Function (EEPROM)	41
10-16) Option Table	43

Temp Control & Operation Functions

10-1) DISPLAY DESIGN



10-2) Temp Control Function

1) Freezer Temperature Control



※ When the Freezer button is pressed, the current set temp will be displayed. And, when the button is pressed again within 5 seconds, it will carry out the following 1-2) and when there is no button press, it will go back to the previous display.

1-1) The temperature will be selected between 8 °F and -14 °F at an interval of 2 °F by pressing one button.

1-2) The temperature will be selected in the following order.

(-2 °F → -4 °F → -6 °F → -8 °F → -10 °F → -12 °F → -14 °F → 8 °F → 6 °F → 4 °F → 2 °F → 0 °F)

1-3) When power is on or there is a power failure, it will display the real temperature.

(It displays the real temperature when a function button is pressed)

1-4) The STD temperature for each step is as follows. (Based on 1/3H copper bar)

Step	1	2	3	4	5	6	7	8	9	10	11	12
Temp	8°F	6°F	4°F	2°F	0°F	-2°F	-4°F	-6°F	-8°F	-10°F	-12°F	-14°F

1-5) When the Freezer button is pressed, 7-SEG will be changed immediately. But, its function will go into operation in 10 seconds.

Temp Control & Operation Functions

2) Fridge Temperature Control



- 2-1) The temperature will be selected between 46 °F and 34 °F at an interval of 2 °F by pressing one button.
- 2-2) When the Fridge button is pressed, the current set temp will be displayed. And, when the button is pressed again within 5 seconds, it will carry out the following 2 -3) and when there is no button press for 10 seconds, it will display the finally selected temperature.
- 2-3) The temperature will be selected in the following order.
(38 °F → 36 °F → 34 °F → 46 °F → 44 °F → 42 °F → 40 °F)
- 2-4) When power is on or there is a power failure, it will display the real temperature.
(It displays the real temperature when a function button is pressed)
- 2-5) The STD temperature for each step is as follows. (Based on 1/3H copper bar)

Step	1	2	3	4	5	6	7
Temp	46°F	44°F	42°F	40°F	38°F	36°F	34°F

- 2-6) When the Fridge button is pressed, 7-SEG will be changed immediately. But, its function will go into operation in 10 seconds.

10-3) Super Freeze Function and Super Cool Functions

1) Super Freeze Function



- 1-1) It is selected by pressing the Super Freeze button.
- 1-2) When the Super Freeze button is pressed once, Super Freeze will be turned on. And then, it will repeat Off and On each time you press the button after the above
- 1-3) With the initial Power On, the LED is off. (When the F-Room temperature is over 41°F (5 °C))

Category	Initial Power On	Pressed Once	Pressed Again	Other
Display Change	OFF	Super Freeze	OFF	

- A. When it goes into Super Freeze with the Super Freeze button pressed, the LED will be changed immediately. But, its function will go into operation in 10 seconds.
(Comp and Fan will operate continuously for 2 and a half hours.)
- B. When Super Freeze is selected, it goes into operation regardless of the compartment temperature.
- C. During the operation of Super Freeze, the fridge compartment will be controlled according to the Fridge Notch setting.
- D. The Freezer display will show the real temperature.

Temp Control & Operation Functions

2) Super Cool Function



2-1) It is selected by pressing the Super Cool button.

2-2) When the Super Cool button is pressed once, Super Cool will be turned on. And then, it will repeat Off and On each time you press the button.

2-3) With the initial Power On, the LED is off. (When the F-Room temperature is over 41°F (5 °C))

Category	Initial Power On	Pressed Once	Pressed Again	Other
Display Change	OFF	Super Cool	OFF	

A. When it goes into Super Cool with the Super Cool button pressed, the LED will be changed immediately. But, its function will go into operation in 10 seconds.

(Comp and Fan will operate continuously until it reaches to 28 °F.)

B. Comp and R-Fan will operate continuously until it reaches to 28 °F. But, the operation time will not exceed 2 and a half hours.

C. During the operation of Super Cool, the freezer compartment will be controlled according to the Freezer Notch setting.

※ Super Freeze and Super Cool Functions

Each function will go into operation independently. With Super Freeze, Comp and F-Fan will operate continuously for 2 and a half hours regardless of the Fridge compartment and with Super Cool, Comp and R-Fan will operate continuously until the Fridge compartment reaches to 28 °F.

Note

When Super Freezer or Super Cool is selected with the Freezer temperature over 14 °F and the Fridge temperature over 50 °F it will operate differently. But, it is not a normal case. So, the explanation will be skipped.

Temp Control & Operation Functions

10-4) Ice Off Function

1) Ice Off Function



- 1-1) Year 2005 W2 Model is one with Auto Ice Maker and Ice Water Valve.
- 1-2) When the Ice Off button is pressed, the Auto Ice Maker does not operate.
- 1-3) Ice stored in the ice bin is available with the Ice Off button selected.
- 1-4) The Auto Ice Maker function is introduced in the Ice Maker function.

10-5) Child Lock Function

1) Child Lock Function

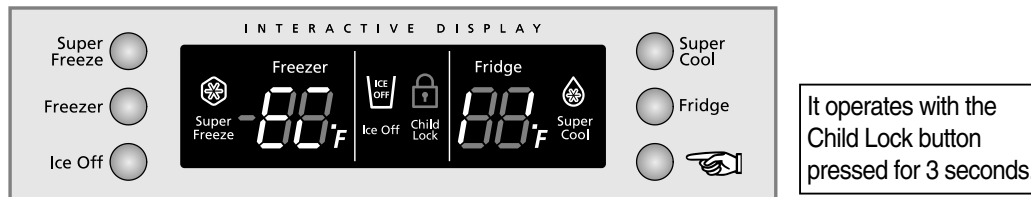

- 1-1) When the Child Lock is selected, the Child Lock LED will light up. Press the button one more time to cancel its function. When the Child Lock is selected, all of the function buttons do not operate. So, temperature control, Super and Ice Off functions will keep their current settings. It is devised to prevent children from changing the settings.
 - 1-2) When the Child Lock button is pressed, the Child Lock LED will light up and when its function is cancelled, the Child Lock LED will go off and other buttons will work.
- Select the function if necessary. But, keep it in mind that this function can bring up consumer calls. So, have a better understanding of it.

Temp Control & Operation Functions

10-6) Buzzer Alarm Function

1) Button Touch Tone ("DING-DONG")

- 1-1) When each button on the control panel is pressed, it will send out an input signaling "DING-DONG" sound.
- 1-2) When buttons are not pressed correctly, it won't send out the "DING-DONG" sound.
- 1-3) Buttons are recognized within 0.2 sec and when buttons are pressed continuously, it sends out only a "DING" sound.
- 1-4) This Button Touch sound has priority over other alarm sounds.

2) Door-Open Alarm Sound

- 2-1) With either of the doors open for more than 2 minutes continuously, it sends out a "Ding Dong" sound.
- 2-2) When the door keeps being opened, it will send out the "DING-DONG" sound every minute.
- 2-3) The alarm sound will stop immediately when both of the doors are closed.

3) Alarm Sound for Forced Operation & Forced Defrost ("BEEP" Sound)

- 3-1) When Forced Operation or Forced Defrost is selected, it will send out a "BEEP" sound.
- 3-2) When the Forced Operation button is pressed once, the "BEEP" sound (0.25Sec ON/0.75Sec OFF) will keep on until it is cancelled automatically (24 Hr) or forcefully.
- 3-3) During Forced Operation, it will send out a "BEEP" sound until the Defrost is completed (idling time included) or the cancellation is selected.
- 3-4) With Forced R-Defrost, it will send out a "BEEP" sound (0.1sec ON/0.75sec OFF) and with Forced F/R-Defrost, it will send out a "BEEP" sound (0.5sec ON/0.5sec OFF).

10-7) Machine Compartment F-Fan Motor Delay Function

- 1) The fridge is automatically controlled by temperature control programs according to the ambient temperature. The machine compartment fan is controlled as follows according to the ambient temperature. The fan does operate or does not operate according to operating conditions with Comp on. So, make sure to take it into consideration during service.

	Temp Range	Load Operation Status
Machine Compartment Fan Delay Function	Ambient Temp 71.6°F (22°C) or over	Machine Compartment Fan On with Comp On
	Ambient Temp 62.6°F (17°C) ~ 69.8°F (21°C)	Machine Compartment Fan On in 3 minutes after Comp On
	Ambient Temp 53.6°F (12°C) ~ 60.8°F (16°C)	Machine Compartment Fan On in 6 minutes after Comp On
	Ambient Temp 44.6°F (7°C) ~ 51.8°F (11°C)	Machine Compartment Fan On in 9 minutes after Comp On
	Ambient Temp 42.8°F (6°C) or under	Machine Compartment Fan Off regardless of Comp

Temp Control & Operation Functions

10-8) Ice Maker Function (Only applicable to Model with the Auto Ice Maker function)

- This Ice Maker function is an option. So, the following can be applied only to Model mentioned.
- Ice Maker has an automatic ice production function without extra controlling by users. It is a kit performing a series of automatic ice producing operation that it supplies water and stores ice in the ice bin upon the completion of ice production.

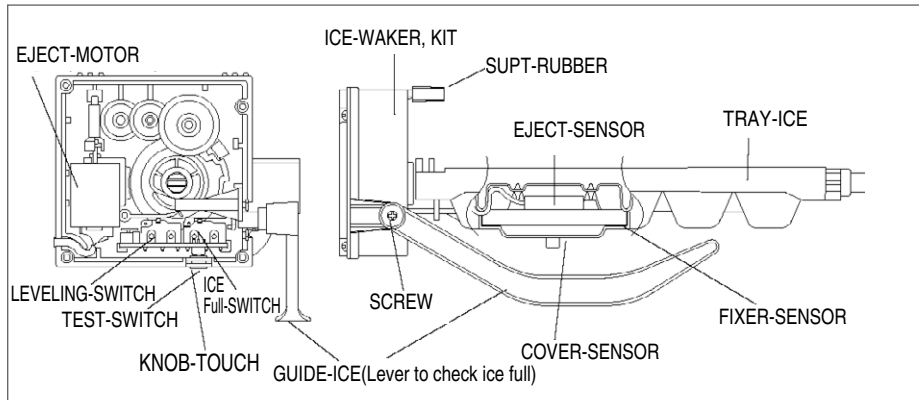

1) Initial Operation Function

- 1-1) When the initial power is applied, the ice tray will stand by for 2 hours.
- 1-2) After the 2-hour standby time, the Ice Maker Sensor will check the temperature and when it is lower than 5°F (-15°C) for more than 5 minutes, it will separate the ice from the ice tray into the ice bin by rotating and twisting the ice tray. At this time, it carries out the ice separation whether there is ice in the ice tray or not.

2) Water Supply Function

- 2-1) Upon the completion of ice separating operation (initial ice separating operation, normal ice separating operation, ice separating operation by Test function) and the horizontal leveling of the ice tray, when it is evaluated that the ice tray is horizontally leveled, water will be supplied to the ice tray by turning on the Water Solenoid in the machine compartment. (When it is detected as no water supply with low water pressure taken into consideration, it will perform water supply operation up to 4 times.)

2-2) Water Supply Operation

- The Water Supply Valve opens after the completion of normal ice ejection, water is supplied for the previously set option time (Factory set value: 5.0 sec) and the Water Supply Valve is shut off.
- Water is to be supplied regardless of F/R-Door Open.
- The Ice Test S/W does not operate during water supply.
- After the water supply is completed, it will evaluate Water Supply or No Water Supply one and a half minutes later.
- When it becomes water supply condition due to no water supply, water supply time will be 1.5 sec, 1 sec and 2 sec.
- When it is judged to do water supply after the 4-time water supply attempts, water supply operation will stop. In this case, the ice eject will standby for 58 minutes.
- To prevent additional water supply due to the remaining ice in the ice tray slot with the ice maker sensor on the bottom of it, it will stop water supply operation when there are no water supply signals keep on after the water supply attempts for the number of previous water supply. For the first time water supply after the power on, it will perform water supply once and if it is sensed as no water supply, it will stop water supply operation. If the number of previous water supply is 3 times, it will try to supply water for 3 times. And, if it is sensed as no water supply, it will stop water supply operation. In this case, the ice eject standby time is 70~110 minutes.
- When it is sensed as no water supply continuously, it will carry out water supply operation for the number of previous water supply +1 times.

Temp Control & Operation Functions

2-3) Water Supply/No Water Supply Evaluation by Ice Maker Sensor

- When it passes one and a half minutes after the completion of water supply, it will evaluate Water Supply/No Water Supply by comparing the temp changes of the Ice Maker Sensor on the bottom of the Ice Tray. If the temperature of the Ice Maker Sensor is 35.6 °F (2 °C) (5 COUNT) higher when it is measured in one and a half minutes after the completion of water supply operation than when it is measured upon the completion of water supply, it will be evaluated as Water Supply. And, if it is increased by lower than 35.6 °F (2 °C) or decreased, it will be evaluated as No Water Supply.

2-4) Water Supply Operation Spec with Ice Test S/W Input

- It will carry out water supply for once regardless of the previous water supply status.
- The ice eject standby time after the completion of water supply is the same as that after the completion of the previous water supply regardless of the recognition of Water Supply/No Water Supply.
- The number of the previous water supply does not change. In other words, if the number of water supply before the Ice Test S/W is pressed is 3 times, the number of previous water supply after the completion of water supply by the Ice Test S/W is 3 times.

※ Example of Water Supply according to Water Pressure

On the Assumption of Room Temp over 18 °C

Low Water Pressure

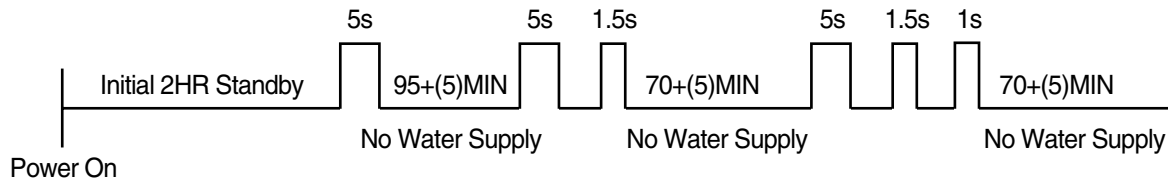

High Water Pressure

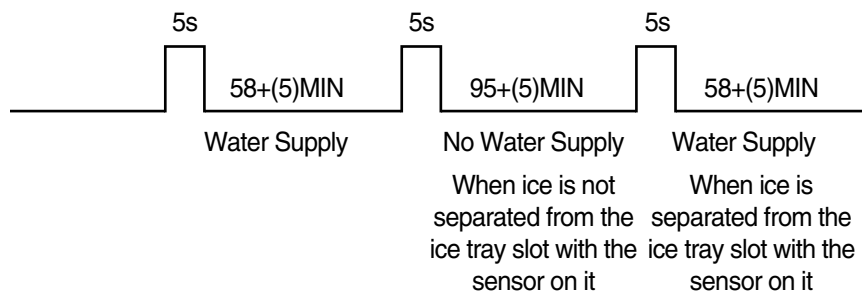

High Water Pressure → Low Water Pressure

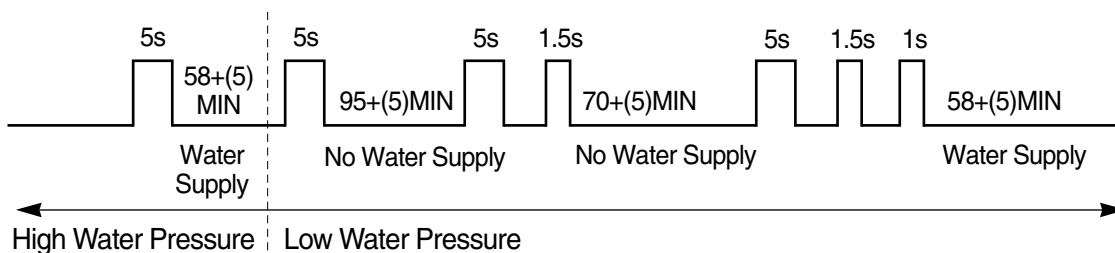

Temp Control & Operation Functions

Low Water Pressure → High Water Pressure

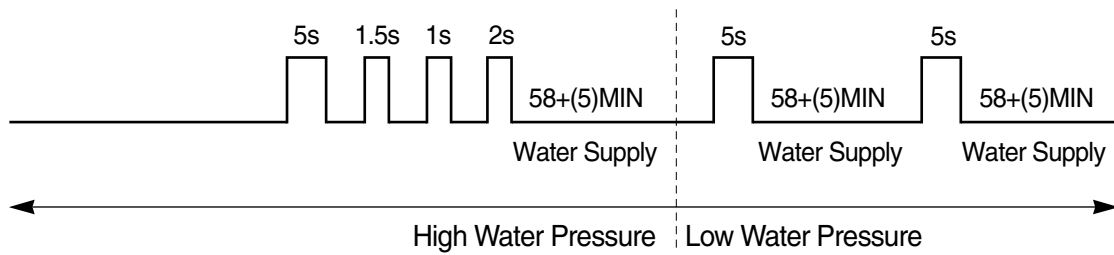

3) Ice Making Function

- It is until the water in the Ice Tray is judged as completely frozen after the completion of water supply operation. And, it is judged by the sensor temperature (can be set to other values).

3-1) When it passes 58 minutes after water is supplied to the Ice Tray, the Ice Maker Sensor temperature will be.

3-2) When the Ice Maker Sensor maintains lower than 5°F (-15°C) for 5 minutes, it will be evaluated as the completion of ice making.

3-3) Standby for One Cycle: After the completion of the initialization with the power on, it will standby for a cycle (2 hours) and carry out the ice ejecting operation even if the temperature conditions of the Ice Maker Sensor are satisfied.

4) Ice Ejection Function

- After the completion of the ice making operation, the operation of ice separation from the ice tray will be carried out as follows. Ice ejection will be performed by checking the status and the time of the Horizontal S/W (if available) and the Lever S/W. When it is sensed as No Water Supply, it will carry out ice ejection for twice in case ice is not separated from the ice tray.

※ Motor Rotating Directions

- CW Rotation: The motor rotates in clockwise direction.

- CCW Rotation: The motor rotates in counter clockwise direction.

4-1) 1) Detailed movements by step during Ejection.

- 1st step : Ejection Temp Check

Check whether the temp sensor is below -15 °C and whether the Ejection Standby time after Water Supply has passed. At this time, the Ejection Standby time will be reset when it goes into F-Defrost during the standby and it will be recounted from the beginning after the completion of Defrost. Then, it checks if 58(58~110) minutes has passed. If the Ice Maker Sensor temp gets 5 °F (-15 °C) or lower and maintains it for 5 minutes, it will carry on the next step.

- 2nd step : Full Ice Bin Check

To check if the ice bin is full, it will check whether the Ice Full S/W is ON/OFF (Low/High).

If the Ice Full S/W is ON (Low), it means the ice bin is full and it will standby without ejection. And as the Ice Full S/W signal is changed to OFF and it will carry out the ejection in 40 minutes.

- 3rd step : Ice Tray Rotation (clockwise)

The Eject Motor rotates clockwise for a certain time and turns over the ice tray. At this point, the Feeler Arm will be raised up to prevent ice from contacting it. The ice tray will rotate for up to one minute or until the Leveling S/W is ON (Low) after 5 sec. from the beginning of the third step when referring to the Leveling S/W. If F-Door is open, it will stop rotating and resume the operation when the door is closed. During the pause, clockwise rotation will not be counted.

- 4th step : Ice Ejection (Standby for 2 sec. at the maximum twist point)

It is operation twisting the ice tray one more time with its reversed state to separate ice from the ice tray completely. The ice tray will standby for 2 seconds at the maximum twist point.

Temp Control & Operation Functions

- 5th step: Restoration to Horizontal State (counter clockwise)

The ice tray restores to its horizontal position by rotating the Ice Eject Motor counter clockwise. When the Leveling S/W is ON (Low) after 5 seconds, it will stop rotating. At this point, the raised Feeler Arm will get lowered again and set on the highest point of stored ice to check the ice level.

- 6th step: Initialization of motor (clockwise)

Upon the completion of ice ejection, it will carry out 2) Water Supply to fill the ice tray.

5) Test Function

- It is to operate forcefully for the purpose of operation tests, A/S, maintenance, etc. And, it operates when the Ice Test S/W (refer to Ice Maker Kit) is pressed for more than one and a half seconds.

5-1) This test button is not selected during water supply or ice ejection. It will carry out the test function when being selected with water supply or ice ejection being completed. When the test button is selected, the Ice Eject Motor will rotate ejecting ice regardless of the ice making temperature. And then, it will be restored to the horizontal level and supply water to the ice tray.

5-2) It operates normally regardless of the F,R-Door opening

5-3) The other functions are the same as the ice ejection and the water supply operation.

5-4) Even when it stops ice-making due to errors more than 3 times during normal operation, the Test S/W shall work. At this time, when it performs normal ice ejection and water supply by pressing the Test S/W, it will send out a "Ding Dong" sound before supplying water and carry out normal ice production by canceling the 3-time error mode.

6) Ice Making Stop (Ice Off Function)



- When there is no demand for ice, turn off the Ice Off button on the display and stop ice making.

6-1) Whenever the Ice Off button is pressed on the display, the Ice Off LED will repeat On (light up) and Off (go off).

6-2) When power comes on, it will check the previously setting and display it. (The F-Room temperature should be lower than 50 °F.)

6-3) If necessary, turn off the ice maker by pressing the Ice Off button. Then, the ice maker will not produce ice.

6-4) When the function is selected, the indicator will be off immediately. But, when the ice maker is supplying water, ejecting ice or performing horizontal leveling, it will stop operating after the completion of the next water supply.

6-5) When the ice making function is selected again, it will accumulate time from the point of the selection and carry out the normal ice making and ejection functions after checking the Ice Maker Sensor temperature in 90 minutes.

7) Function according to F-Door Open

- When F-Door is open, it will stop the operation to minimize the noise.

7-1) When F-Door is open during the ice ejection or horizontal leveling, it will stop operating and resume its operation right after the door is closed again.

7-2) During water supply, it will carry on the water supply regardless of the state of the doors.

7-3) Therefore, when the freezer door is opened, the Ice Tray will stop operating. So you can find that the Ice Tray is slanted or rotated partially with the door open. So, shut off the freezer door and wait for more than 30 seconds. Then, check if the Ice Tray is leveled horizontally. If not, it can be regarded as product failure. When the ice ejection stops upon the opening of the freezer door, the Test function does not work because it is normal operation and it will operate upon the completion of the water supply.

Temp Control & Operation Functions

10-9) Defrost Function

- 1) The F/R-Room defrost depends on the accumulated comp-on time.
- 2) With the initial power on, defrost starts at the both rooms after 4 hour accumulated comp-on time.
- 3) The defrost cycle can be changed from Min 6 hours to Max 7 hours according to various conditions.
- 4) The defrost cycle depends on the ambient temperature, the frequency of F/R-Door open and the duration of the F/R-Door open.
- 5) The Defrost Heater Off temperatures are compared using the temperature values of R-Defrost Sensor and F-Defrost Sensor and they are as follows.

	R-Room	F-Room	E t c
Defrost Start	Lower than 50°F (10°C)	Lower than 23°F (-5°C)	
Defrost Restoration Temp	62.6°F (17°C)	53.6°F (12°C)	

Note

Defrost restoration temperatures could be changed without notice for the purpose of performance improvements.

10-10) Test Function

- This function is for PCB, Product and Process Test, and SVC.
- After checking the product functions by selecting Test S/W, turn on the power again.

1) Forced Operation Function



Display for Forced Operation

Display for Forced Operation and How to Turn it On
 ① (Press for 8 seconds simultaneously) +
 ② All LEDs Off, Press one of the following buttons (Super Freeze, Super Cool, Freezer, Fridge Key)

- 1-1) When the Super Cool button and the Fridge button on the display panel are pressed for 8 seconds simultaneously, the display panel will be shifted to the Test Setting Mode and all the LEDs will be off.
- 1-2) When any of Super Freeze, Super Cool, Freezer and Fridge buttons is pressed within 15 seconds with the display panel shifted to the Test Setting Mode, it will be selected in the order of Forced Operation → Forced R-Defrost → Forced F/R-Defrost → Cancel.
- 1-3) When there is no button press within 15 seconds after the display panel is shifted to the Test Setting Mode, it will go back to the previous display mode.
- 1-4) When the Test Setting Mode is selected or cancelled, it will send out a "BEEP" sound.
- 1-5) When Forced Operation is selected, the F-Room LED will display "FF" and the R-Room LED will display its real compartment temperature.
 But, when it passes more than a minute with Forced Operation selected, and then Forced Defrost or Test Cancellation is selected, the temperature setting will not be changed (maintaining -14 °F and 34°F)
 When Forced Defrost or Test Cancellation is selected within a minute after Forced Operation is selected, the Notch will go back to the previous notch setting.
- 1-6) During Forced Operation, the Full-Down function will be maintained only for 24 hours. After that, it will go in to normal operation after carrying out F/R-Defrost automatically.

Temp Control & Operation Functions

- 1-7) To cancel Forced Operation, turn off and on the power or select the Test Cancellation Mode.
- 1-8) It will send out an alarm sound (0.25sec ON/0.75sec OFF) during Forced Operation until it is completed.
It will keep on alarming regardless of the selection or cancellation of the alarm button.
- 1-9) When Forced Operation is selected, Super Freeze and Super Cool won't operate.

2) Forced Defrost Function

- 2-1) When the Test button is pressed one more time during Forced Operation, it will go into R-Room Forced Defrost.



Display for Forced R-Defrost
-. Press one of Super Freeze, Super Cool, Freezer, Fridge buttons once during Forced Operation

- 2-2) When it is selected once more, it will go into F/R-Defrost.



Display for Forced F/R-Defrost

Display for Forced F/R-Defrost
-. Press one of Super Freeze, Super Cool, Freezer, Fridge buttons once during Forced R-Defrost Operation

- 2-3) When it goes into Forced Defrost, Forced Operation will be cancelled automatically.
And then, it will carry out normal operation after completing Forced Defrost.

3) Test Cancellation Mode

- 3-1) When the Test button is pressed once more during F/R-Forced Defrost, it will go back to normal operation.
- 3-2) When the Test Cancellation Mode is selected, it will stop alarming.

10-11) Function when the power is applied for the first time.

- 1) When power is applied, it will carry out the initial self diagnosis. And, if there is no error, all the LEDs on the display panel will light up for 2 seconds.
- 2) When there is any error found during the initial self diagnosis, relevant LEDs will blink at an interval of 0.5 sec.
- 3) After lighting up all the LEDs for 2 seconds, the display panel will display the real temperatures of the F-Room and the R-Room.
- 4) It will turn on R-Defrost Heater and F-Defrost Heater at an interval of 0.5 sec and keep them being turned on for 3 seconds.
- 5) When the initial F/R-Defrost is completed, COMP, C-FAN, F-FAN and R-FAN will be on at an interval of 0.5 sec and they will operate for 5 minutes regardless of the compartment temperatures.
- 6) When the Test S/W is pressed during 4) and 5), the functions related to 4) and 5) will stop immediately and it will go into the Test function.

Temp Control & Operation Functions

10-12) Power Compensation Function

1) Notch Save Function

- 1-1) Whenever the Super Freeze, Super Cool, Fridge or Freezer button is pressed, it will save the current display setting. And, when the power goes off and comes back on, it will display the stored setting. (But, the Test Mode will not be saved.)
- 1-2) Upon the initial power on, the above 1-1) will be performed when the F-Room temperature is lower than 41°F (5°C) and it will operate on the initial mode regardless of the saved setting when the temperature is over 41°F (5°C).
- 1-3) When the power goes off during Super Freeze and comes back on, it will carry out Super Freeze when the F-Room temperature is lower than 41°F (5°C). But, the previously accumulated operating time will be reset and it will count from the start.
- 1-4) When the power goes off during Super Cool and comes back on, it will carry out Super Cool when the F-Room temperature is lower than 41°F (5°C). But, the previously accumulated operating time will be reset and it will count from the start.
- 1-5) When the power is off with various functions in operation, it will light up the entire display for about 3 seconds from the power-on point regardless of the notch save if the F-Room temperature is lower than 41°F (5°C).

※ Exhibition Mode

- When the Super Freeze and the Freezer buttons are pressed for 5 seconds simultaneously, it will go into the Exhibition Mode with a “Ding-Dong” sound.
- With the Exhibition Mode selected, the compressor will be off immediately and there will be no defrost.
- Press the Super Freeze and the Freezer buttons for 5 seconds simultaneously to cancel the Exhibition Mode. Then, it will carry out the normal operation.

10-13) Self Diagnosis Function

1) Self-diagnosis with initial power on

- 1-1) With power on, MICOM checks the temperature sensors for errors in a second.
- 1-2) If inferior sensor is found by self-diagnosis, relevant display LEDs will be all on and off at the interval of 0.5 sec. (There will be no beep sound with at this time.)
- 1-3) When display LEDs are blinking with inferior sensors found, it only recognizes the self-diagnosis buttons and normal temp control will be on hold.
- 1-4) Upon self-diagnosis error, when the faulty sensor is repaired or when the Super Freeze button and the Super Cool button are pressed for 5 sec simultaneously, the initial self diagnosis will be canceled automatically. (Below, How to Select)

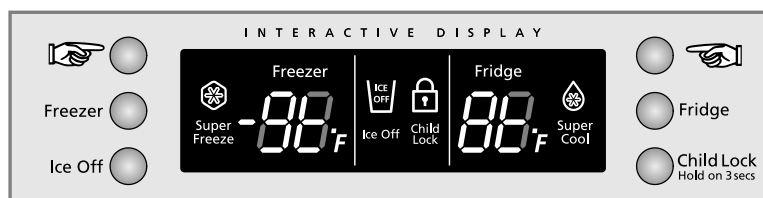

Temp Control & Operation Functions

2) Self-diagnosis with initial power on



- 2-1) When pressing the Super Freeze button and the Super Cool button simultaneously for 6 sec during normal operation, the entire temperature setting display will blink for 2 sec at the interval of 0.5 sec and when pressing the Super Cool button and the Super Cool button simultaneously for 8 sec including 2 sec blinking, self-diagnosis will be selected.
- 2-2) It goes into the Self Diagnosis function with a “Ding-Dong” sound and it shows error codes on the LED display. And then, it will be restored to the normal operation.
- 2-3) During self-diagnosis, button inputs will not be recognized but only the canceling buttons.

- Self Diagnosis Check List

No	Error	LED Display	Description	Others
1	F-SENSOR ERROR		Fault rated F-SENSOR?	
2	R-SENSOR ERROR		Fault rated R-SENSOR?	
3	F-DEFROST SENSOR ERROR		Fault rated F-DEFROST SENSOR?	
4	R-DEFROST SENSOR ERROR		Fault rated R-DEFROST SENSOR?	
5	ICE MAKER SENSOR ERROR		Fault rated ICE MAKER SENSOR?	
6	AMBIENT SENSOR ERROR		Fault rated AMBIENT SENSOR?	
7	F-DEFROST HEATER ERROR		Fault rated F-DEFROST?	
8	R-DEFROST HEATER ERROR		Fault rated R-DEFROST?	
9	ICE MAKER FUNCTION ERROR		Fault ICE MAKER OPERATION?	
10	U-ART TELECOM ERROR		Fault SENSOR?	

Temp Control & Operation Functions

- Descriptions for each Self Diagnosis Lamp

No	Item	Error	Self Diagnosis
1	F-SENSOR	SENSOR HOUSING SLIP-OUT, CONTACT DEFECT, WIRE CUT, WIRE SHORT, SENSOR TEMP MORE THAN 122°F (+50°C) OR LOWER THAN 122°F (-50°C)	VOLTAGE BETWEEN MAIN PCB CN30 2↔3 SHALL BE WITHIN 4.5V~1.0V.
2	R-SENSOR	SENSOR HOUSING SLIP-OUT, CONTACT DEFECT, WIRE CUT, WIRE SHORT, SENSOR TEMP MORE THAN 122°F (+50°C) OR LOWER THAN 122°F (-50°C)	VOLTAGE BETWEEN MAIN PCB CN30 6↔7 SHALL BE WITHIN 4.5V~1.0V.
3	F-DEFROST SENSOR	SENSOR HOUSING SLIP-OUT, CONTACT DEFECT, WIRE CUT, WIRE SHORT, SENSOR TEMP MORE THAN 122°F (+50°C) OR LOWER THAN 122°F (-50°C)	VOLTAGE BETWEEN MAIN PCB CN30 2↔4 SHALL BE WITHIN 4.5V~1.0V.
4	R-DEFROST SENSOR	SENSOR HOUSING SLIP-OUT, CONTACT DEFECT, WIRE CUT, WIRE SHORT, SENSOR TEMP MORE THAN 122°F (+50°C) OR LOWER THAN 122°F (-50°C)	VOLTAGE BETWEEN MAIN PCB CN30 6↔8 SHALL BE WITHIN 4.5V~1.0V.
5	I/M-SENSOR	SENSOR HOUSING SLIP-OUT, CONTACT DEFECT, WIRE CUT, WIRE SHORT, SENSOR TEMP MORE THAN 122°F (+50°C) OR LOWER THAN 122°F (-50°C)	VOLTAGE BETWEEN MAIN PCB CN90 3↔4 SHALL BE WITHIN 4.5V~1.0V.
6	AMBIENT SENSOR	SENSOR HOUSING SLIP-OUT, CONTACT DEFECT, WIRE CUT, WIRE SHORT, SENSOR TEMP MORE THAN 122°F (+50°C) OR LOWER THAN 122°F (-50°C)	VOLTAGE BETWEEN MAIN PCB CN31 1↔4 SHALL BE WITHIN 4.5V~1.0V.
7	F-DEFROST ERROR	F-ROOM HEATER (SENSOR HOUSING SLIP-OUT, CONTACT DEFECT, WIRE CUT, WIRE SHORT OR TEMP FUSE DEFECT) WHEN DEFROST DOES NOT FINISH EVEN AFTER A 70-MINUTE CONTINUOUS HEATING, IT DISPLAYS THE ERROR.	AFTER SEPARATING THE MAIN PCB CN70 WIRE FROM PCB, CHECK THE RESISTANCE BETWEEN BROWN ↔ ORANGE. IT SHALL BE WITHIN ***OHM. (THE RESISTANCE VARIES ACCORDING TO THE INPUT POWER.) WHEN THE RESISTANCE IS 0 OHM, CHECK IF THE HEATER IS SHORT AND WHEN IT IS ∞OHM, CHECK IF THE WIRE/TEMP FUSE IS OPEN
8	R-DEFROST ERROR	R-ROOM HEATER (SENSOR HOUSING SLIP-OUT, CONTACT DEFECT, WIRE CUT, WIRE SHORT OR TEMP FUSE DEFECT) WHEN DEFROST DOES NOT FINISH EVEN AFTER A 80-MINUTE CONTINUOUS HEATING, IT DISPLAYS THE ERROR.	AFTER SEPARATING THE MAIN PCB CN70 WIRE FROM PCB, CHECK THE RESISTANCE BETWEEN WHITE ↔ ORANGE. IT SHALL BE WITHIN ***OHM. (THE RESISTANCE VARIES ACCORDING TO THE INPUT POWER.) WHEN THE RESISTANCE IS 0 OHM, CHECK IF THE HEATER IS SHORT AND WHEN IT IS ∞OHM, CHECK IF THE WIRE/TEMP FUSE IS OPEN
9	I/M FUNCTION ERROR	MORE THAN 3 TIMES OF ICE MAKER KIT ICE EJECTION OR HORIZONTAL LEVELING ERROR	ONLY APPLIED TO MODEL WITH ICE MAKER
10	U-ART TELECOM ERROR	LED IS DISPLAYED WITH THE SENSOR ERROR SIMULTANEOUSLY	IF SENSOR ERROR IS REPAIRED, LED IS RECOVERED PROMPTLY

Temp Control & Operation Functions

10-14) Power Compensation Function



It is the initial Sensor Error Display. Hold on the Super Freeze and the Super Cool buttons for 3 seconds and take off the fingers. Then, press the Fridge button.

- 1) During the normal operation, when the Super Freeze and the Super Cool buttons are pressed for 3 seconds at the same time, the Freezer and the Fridge temp LEDs will blink for 2 seconds at the interval of 0.5 second.
- 2) At this time, when pressing the Fridge button ("Ding-Dong" goes off) after taking off the fingers from the Super Freeze and the Super Cool buttons, it will be changed to the Load Status Display Mode.
- 3) The Load Status Display Mode only shows the status of the load operation command from MICOM. MICOM sends out command signals. So, it does not mean the related components are in operation. For example, even though it shows that a load is operating, it is not operating due to the load defect or the PCB relay defect. It can be applied to A/S.
- 4) The Load Status Display function maintains for 30 seconds and it goes back to the normal operation.

- Self Diagnosis Check List

LOAD	DISPLAY	OTHERS
R-FAN	R-Room second digit "a"	
R-DEFROST HEATER	R-Room second digit "c"	
COMPRESSOR	F-Room second digit "a"	
F-FAN	F-Room second digit "b"	
F-DEFROST HEATER	F-Room second digit "d"	
INITIAL START MODE	R-Room second digit "d"	
OVERLOAD MODE	R-Room second digit "e"	
LOW TEMP MODE	R-Room second digit "f"	
R-LAMP	F-Room first digit "b"	
F-LAMP	F-Room first digit "a"	
EXHIBITION MODE	R-Room second digit "g"	

Temp Control & Operation Functions

10-15) Option Setting Function (EEPROM)

- During the normal operation, when the Super Cool and the Freezer buttons are pressed for 12 seconds, the Fridge or Freezer temp setting display will be shifted to the Option Setting Mode.

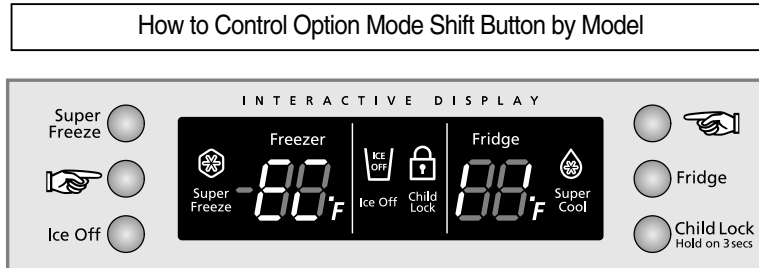

When the Super Cool and the Freezer buttons are pressed for 12 seconds at the same time, the Fridge/Freezer display will be shifted to the Option Setting Mode.

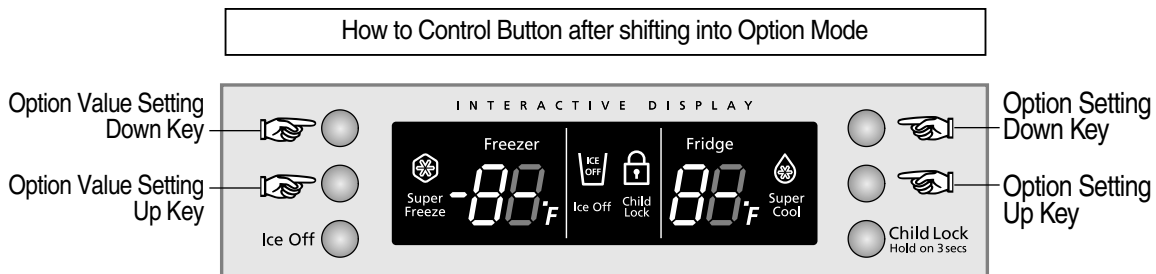

※ Button Press at Option Mode

Press Super Freeze	Option Value Down (Decrease)
Press Freezer	Option Value Up (Increase)
Press Super Cool	Option Moving Down
Press Fridge	Option Moving Up

- When the display is shifted to the Option Setting Mode, all the LEDs will be turned off except Freezer and Fridge. (All the options operate according to the Option Table. So, only Fridge and Freezer will be introduced.)

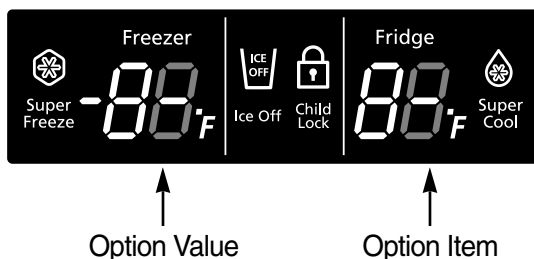

- 1) For example, if you want to change option and shift the standard temp of R-Room to 28.4°F (-2°C), follow the directions below. This function is to change the standard temp and if the current standard temp of F-Room is -2°F (-19°C), it can be lowered by 28.4°F (-2°C) using the options and the standard temp will be controlled at -6°F (-21°C). That is, in the case of changing temp options, although you set it to -2°F (-19°C) on the display panel, the fridge will operate to -6°F (-21°C) internally. Therefore, the temp will be controlled by lowering 28.4 °F (-2°C) compared to that set on the display panel.

Temp Control & Operation Functions

Note

Basically, when sending out products, their option will be all cleared. That is, their set values are all "0". However, for the purpose of quality improvement, set values could be changed. Therefore, make sure to check quality information

- 2) After changing to the Option Mode, the display panel will blink "0" (ALL OFF) for R-Room and "0" (ALL OFF) for F-Room. (When sending out products, there shall be "0" set for R-Room and "0" set for F-Room. But, for the purpose of quality improvement, the standard set values can be changed.)
 - If only "0" for R-Room blinks, F-Room temp option item will be set and the current F-Room temp set value will be shown on the temp display of F-Room.
- 3) After setting "0" for R-Room and selecting "6" as in the option table of F-Room below, the standard temp of F-Room will be lowered by 28.4°F (-2.0°C). (Refer to F-Room temp change figure)

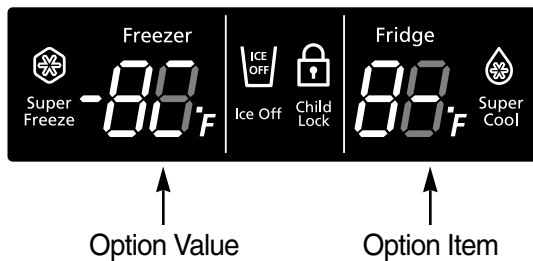

: In 20 seconds after the completion of the adjustment, MICOM will store the set value in EEPROM and it will be restored to the normal display and the option setting mode will be cancelled.

- 4) The above option setting method is the same for all models whether they have Ice Maker or not.
- 5) With the same as the above method, R-Room Temp, Water Supply Qty, Ice Maker Eject Temp/Time, Defrost Restoration Temp, Hysteresis & Notch Gap for each temperature can be controlled.
- 6) **Since option is already set in EEPROM while sending out products at the factory, do not change it randomly except for special occasions and do not turn off power before restoring to the normal display because option will be completed when it is restored to the normal display in 20 seconds.**

Note

There are other options including the functions mentioned above. But, they are related to the fridge controlling. They are dropped here since they are not relevant to A/S. (Do not set other options except for those in this A/S manual.)

Temp Control & Operation Functions

10-16) Option Table

1) F-Room Temp Shift Table

Set Item	F-Room Temp Shift
Model	Common (All Models)
Option Item	Fridge LED
	0

Set Value	Option Value
Freezer LED	
0	0
1	31.1°F(-0.5°C)
2	30.2°F(-1.0°C)
3	29.3°F(-1.5°C)
4	28.4°F(-2.0°C)
5	27.5°F(-2.5°C)
6	26.6°F(-3.0°C)
7	25.7°F(-3.5°C)
8	32.9°F(+0.5°C)
9	33.8°F(+1.0°C)
10	34.7°F(+1.5°C)
11	35.6°F(+2.0°C)
12	36.5°F(+2.5°C)
13	37.4°F(+3.0°C)
14	38.3°F(+3.5°C)
15	39.2°F(+4.0°C)



Option Value

Option Item

Ex) When raising the Freezer standard temperature by 28.4°F(-2°C)

Temp Control & Operation Functions

2) R-Room Temp Shift Table

Set Item	R-Room Temp Shift
Model	Common (All Models)
Option Item	Fridge LED
	1

Set Value	Option Value
Fridge LED	
0	0
1	31.1°F(-0.5°C)
2	30.2°F(-1.0°C)
3	29.3°F(-1.5°C)
4	28.4°F(-2.0°C)
5	27.5°F(-2.5°C)
6	26.6°F(-3.0°C)
7	25.7°F(-3.5°C)
8	32.9°F(+0.5°C)
9	33.8°F(+1.0°C)
10	34.7°F(+1.5°C)
11	35.6°F(+2.0°C)
12	36.5°F(+2.5°C)
13	37.4°F(+3.0°C)
14	38.3°F(+3.5°C)
15	39.2°F(+4.0°C)



Ex) When raising the fridge standard temperature by 35.6°F(+2°C)

Temp Control & Operation Functions

- The following options are only applicable to the models with Ice Maker.
The following can not be set to the models without Ice Maker

3) Ice Maker Sensor Temp Shift

This is the standard temperature checking if ice in the ice tray is frozen completely.

Set Item	LED (Fridge)
Ice Maker Sensor Standard Temp Control	4

Set Value	Option Value
F-Room Temp Set Value	
0	5.0°F(-15°C)
1	3.2°F(-16°C)
2	1.4°F(-17°C)
3	7.8°F(-14°C)
4	8.6°F(-13°C)
5	10.4°F(-12°C)
6	12.2°F(-11°C)
7	14.0°F(-10°C)

Ex) When changing the Defrost Sensor temperature to 1.4°F(-17°C)

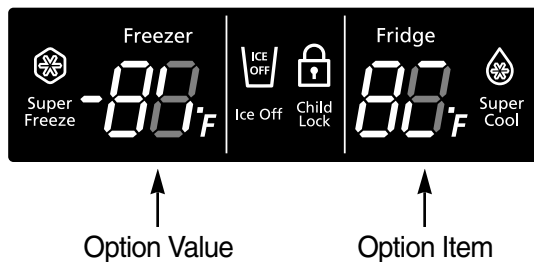

4) Ice Maker Water Supply Time Control Function

It is an option for Water Supply Time and it may be deleted when the time is confirmed at the factory.

Set Item	LED (Fridge)
Ice Maker Water Supply Time Control	20

Set Value	Option Value
F-Room Temp Set Value	
0	5 sec
1	6 sec
2	7 sec
3	8 sec
4	9 sec
5	10 sec
6	11 sec
7	12 sec

Ex) When changing the water supply time to 9 seconds

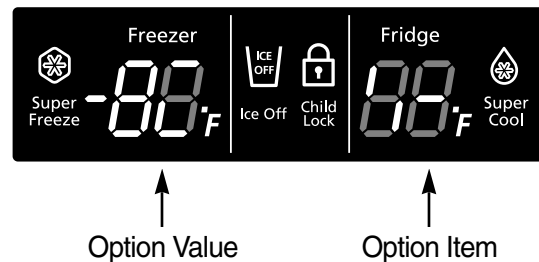



11. OPERATION PRINCIPLES BY PARTS OF CIRCUIT

11-1) SOURCE POWER CIRCUIT	47
11-2) OSCILLATION CIRCUIT	47
11-3) RESET CIRCUIT	48
11-4) EEPROM DETECTION CIRCUIT	48
11-5) DOOR SWITCH DETECTON CIRCUIT	48
11-6) TEMP SENSING CIRCUIT	49
11-7) ICE MAKER OPERATION CIRCUIT	50
11-8) DISPLAY DRIVING CIRCUIT	51
11-9) LOAD DRIVING CIRCUIT	52
11-10) BUZZER CIRCUIT DIAGRAM	53

OPERATION PRINCIPLES BY PARTS OF CIRCUIT

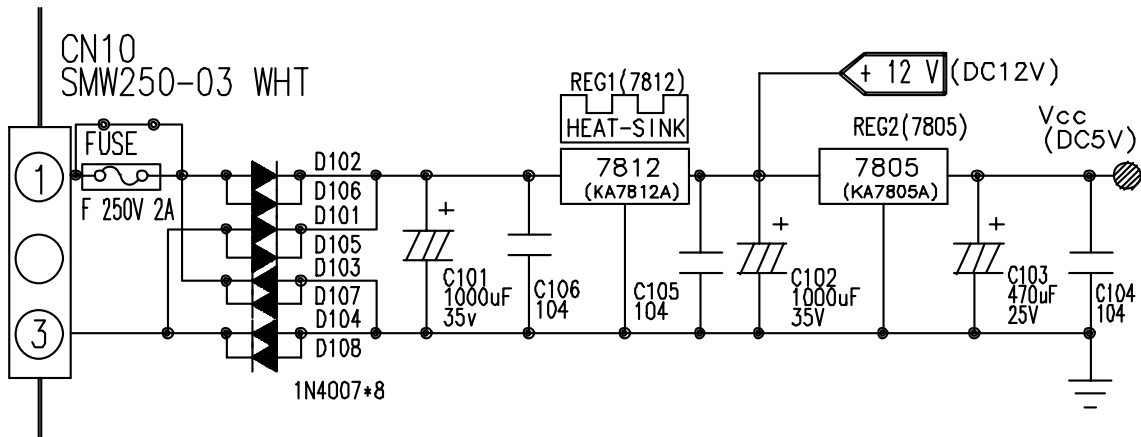
11-1) SOURCE POWER CIRCUIT

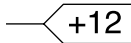

Power	Circuit
 Vcc(DC 5V)	MICOM POWER AND SENSORS
 +12V (DC 12V)	RELAY,PANEL DRIVING CIRCUIT

- 1) When the power is supplied, AC voltage stepped down on the 2nd transformer flows between ① and ③ at about AC 16V and changes to DC voltage when it goes through the diode D101 ~ D108, and constant 12V will be output via regulator REG1(7812). And, it will supply DC5V to MICOM and power to other circuits via regulator REG2 (MC7805ACT), and make entire PCB operate.

11-2) OSCILLATION CIRCUIT

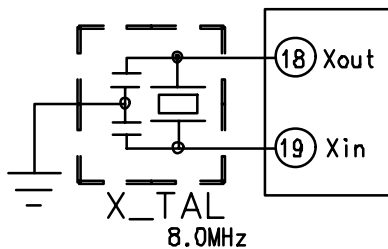

Terminal	Oscillation Freq.
Xin(#19)	8MHz
Xout(#18)	8MHz

- 1) It is an Oscillation Circuit for synchronism clock generation and time calculation on the information sending & receiving of the MICOM internal logic elements and when specifications for Resonator change, the timing system of MICOM changes resulting in errors. (Rated parts must be used)

OPERATION PRINCIPLES BY PARTS OF CIRCUIT

11-3) RESET CIRCUIT

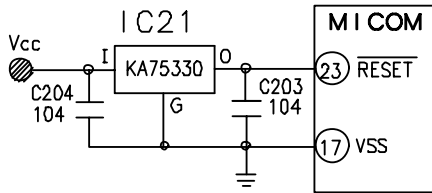

Terminal	Power
Vcc	DC 5V
Reset	DC 5V

- 1) RESET Circuit allows the whole program to go back to the initial setting by initializing parts such as the RAM in MICOM with the power supply into MICOM or with an instant power failure. Upon the power supply, the reset terminal voltage becomes "LOW" for several tens of μs compared to Vcc voltage (DC 5V) at MICOM, and it maintains "HIGH" (Vcc Voltage) during normal operation. But, when Vcc drops down to 3.4~3.7V, the reset terminal voltage becomes "LOW".

11-4) EEPROM DETECTION CIRCUIT

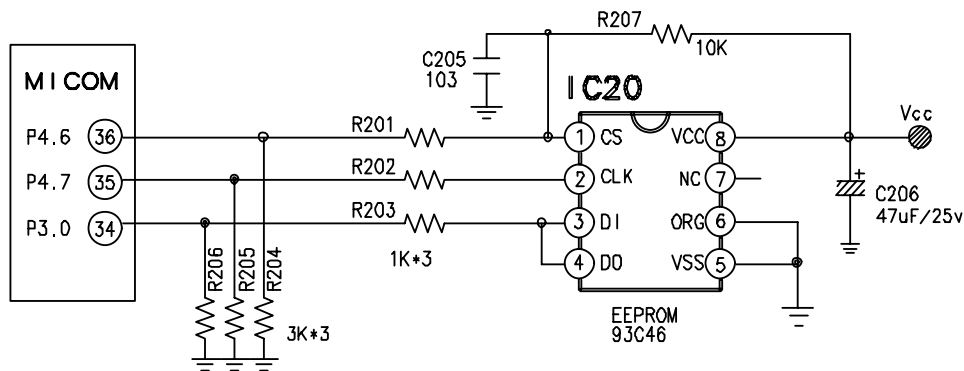

- 1) A semiconductor memory EEPROM stores data remembering previous settings regardless of power-off, which are indispensable especially in power fluctuating areas. Also, EEPROM sets and uses other options in principle.

11-5) DOOR SWITCH DETECTION CIRCUIT

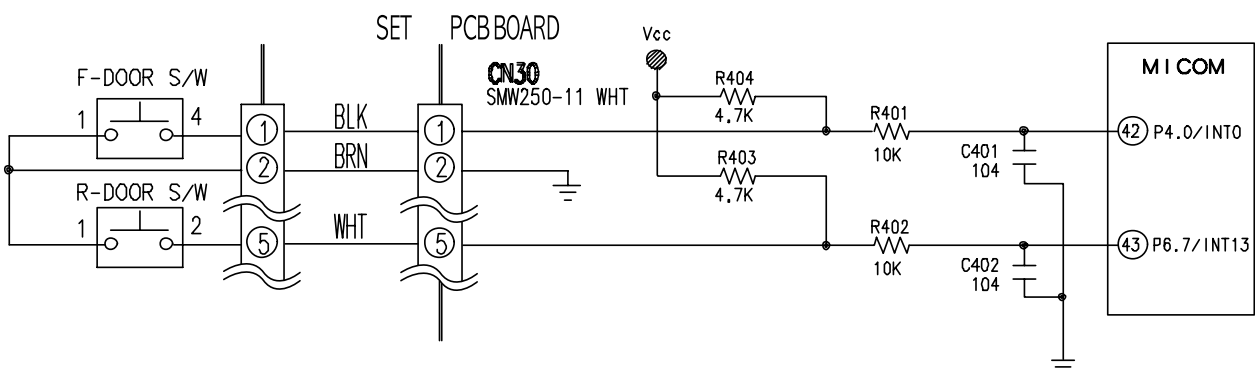

OPERATION PRINCIPLES BY PARTS OF CIRCUIT

ITEM	DOOR OPEN/CLOSE	DOOR S/W CONTACT POINT	MICOM PIN NO	MICOM INPUT
F	CLOSE	OPEN	# 42	“HIGH”
	OPEN	CLOSE		“LOW”
R	CLOSE	OPEN	# 43	“HIGH”
	OPEN	CLOSE		“LOW”

- 1) If F-Door is opened, the contact point of the door switch (4-1) becomes closed. Then, the power of the PCB line flows to the door switch through R404 and 0V is applied to the MICOM terminal. And, when the door is closed, the contact point of the door switch (4-1) becomes open. Then, the power of the PCB line supplies 5V to MICOM via R404 and R401, which recognize the door as closed, turn on the fan at the extra load terminal and control the Room Lamp Relay (K73) turning off the lamp.
- 2) If R-Door is opened, the contact point of the door switch (2-1) becomes closed. Then, the power of the PCB line flows to the door switch through R403 and 0V is applied to the MICOM terminal. And, when the door is closed, the contact point of the door switch (2-1) becomes open. Then, the power of the PCB line supplies 5V to MICOM via R403 and R402, which recognize the door as closed, turn on the fan at the extra load terminal and control the Room Lamp Relay (K75) turning off the lamp.

11-6) TEMP SENSING CIRCUIT

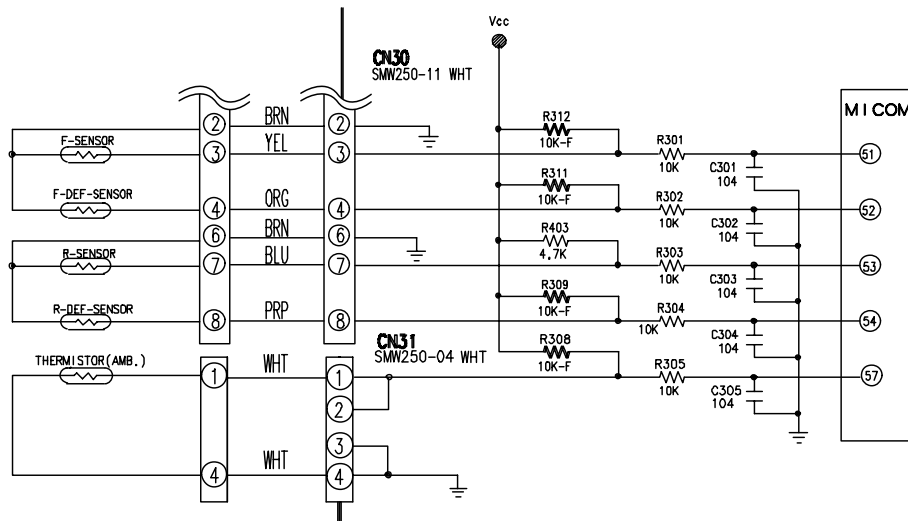

- 1) Sensor uses a thermistor which has a temp coefficient of negative resistance and controls resistance. When the heat goes up, the resistance gets down and vice versa. R301~R305 and C301~C305 are parts for noise prevention but they are not related to temp sensing characteristics.
- 2) If V_f is the incoming voltage to MICOM in case of F-Sensor, V_f equals $(R_{th} * V_{cc}) / ((R_{312} + R_{th}))$. Where R_{th} is resistance of THERMISTOR corresponding to Temp. Please refer to the Appendix Temp-to-Sensor Resistance/Voltage conversion table (Temp-to-MICOM Terminal Voltage included) on A/S. (88page)

OPERATION PRINCIPLES BY PARTS OF CIRCUIT

11-7) ICE MAKER OPERATION CIRCUIT

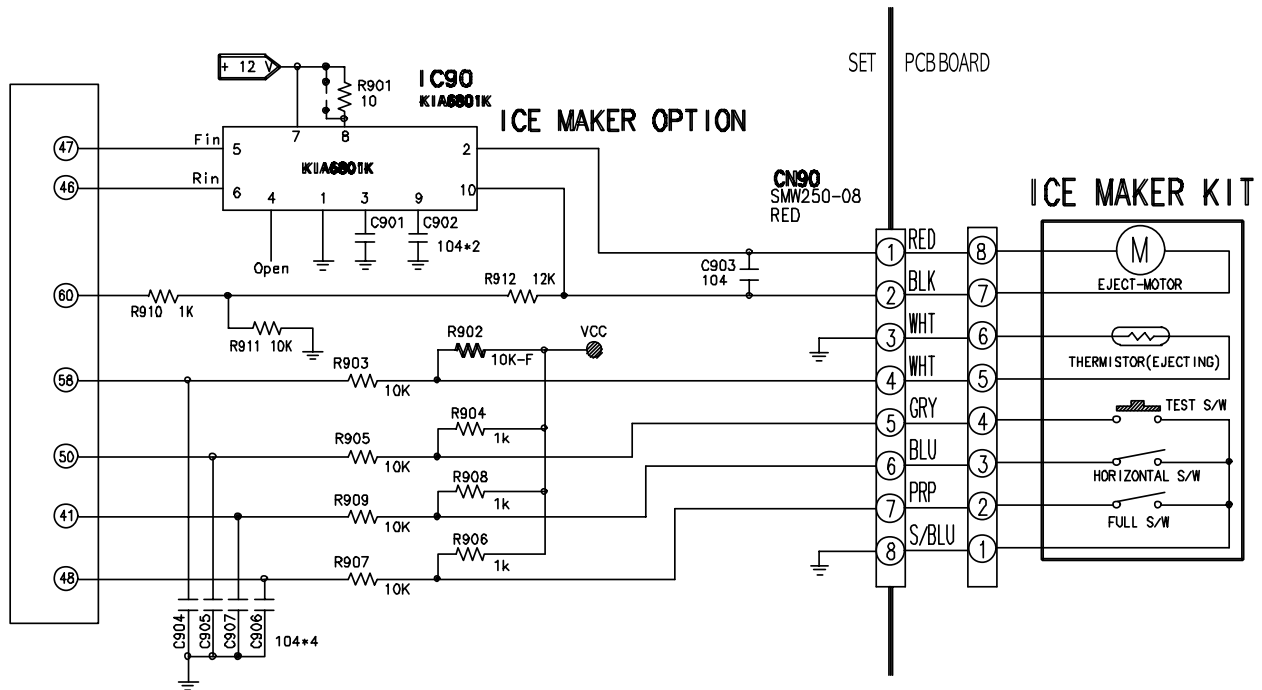

1) The ice maker circuit above is to control the ice maker kit installed on the F room.

This circuit is the hardware to control ejection and horizontal positioning, ice making temperature detection and full icing detection. Temperature detection circuit is the same as temperature detection circuit on 4-6 and the explanation will be skipped and only the ejection circuit will be explained. If MICOM PORT NO #47 is outputted with High to rotate motor in ejection direction and the pin #5 of IC90 is inputted, 12V is outputted on pin #2 of IC90, goes to motor and supplied to pin #10 of IC90. The current flows to the pin #10 of IC90 making motor rotates. This motor rotates the gear and rotates the ejection tray. The tray twists to separate the ice from the tray and return to the horizontal state. For restoration, motor stops for 2 seconds when the ejection is completed and to rotate in opposite direction, output horizontal MICOM PORT NO #46 with high and perform horizontal positioning. Motor rotation for ejection operates for 8.3 seconds and stays for 2 seconds. Horizontal positioning rotates motor in opposite direction and it stops when the horizontal switch becomes ON (Low) or when the voltage of the motor voltage sensing part (MICOM PORT NO #60) is over 0.55V. The test S/W is off in normal cases and MICOM PORT NO #50 stays high. When necessary, press the switch for more than 1.5 seconds executing forced ejection. Full S/W has a lever that detects the amount of ice in the ice-maker kit and based on the status of MICRO S/W connected to the lever, if ice is full in the container, ejection is not executed, and only if it is off (MICOM PORT NO #48 is high), the ejection is executed.

OPERATION PRINCIPLES BY PARTS OF CIRCUIT

11-8) DISPLAY DRIVING CIRCUIT

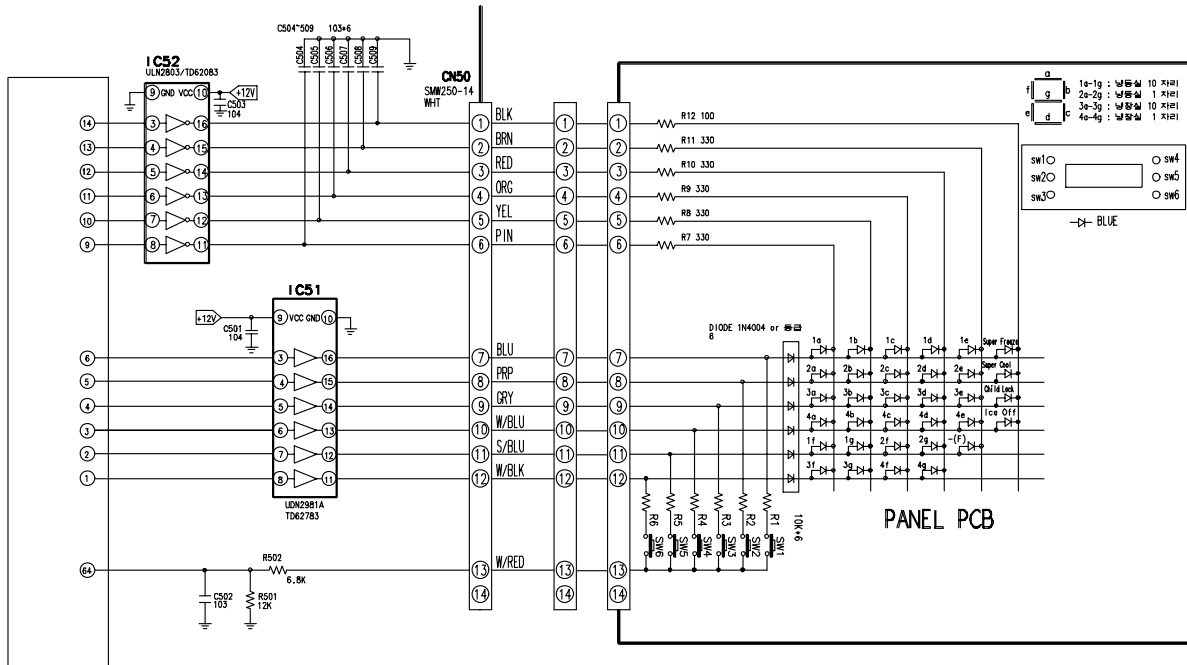

1) KEY SCAN & DISPLAY DRIVING PRINCIPLE

As shown in the wave diagram below, Micom sends out "high" signals through the MICOM 6 terminals of NO #1 → 2 → 3 → 4 → 5 → 6 for 2ms each every 12ms. This signal goes to output terminal via input terminal of IC51 (TD62783AP or KID65783AP). Here, the peak to peak voltage of the square wave is 11~12V DC and each output wave is as follows.

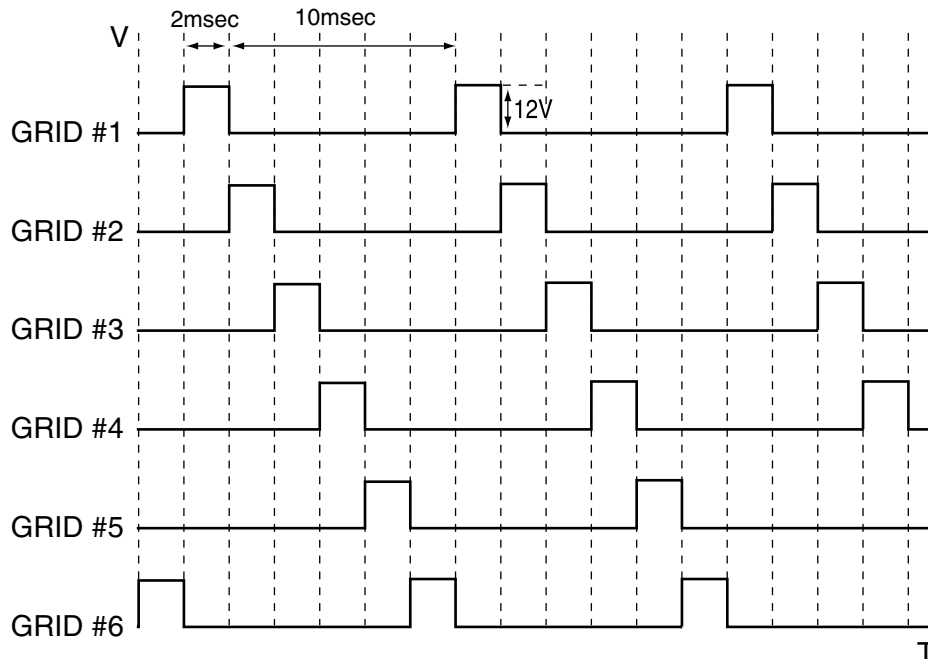

OPERATION PRINCIPLES BY PARTS OF CIRCUIT

11-9) LOAD DRIVING CIRCUIT

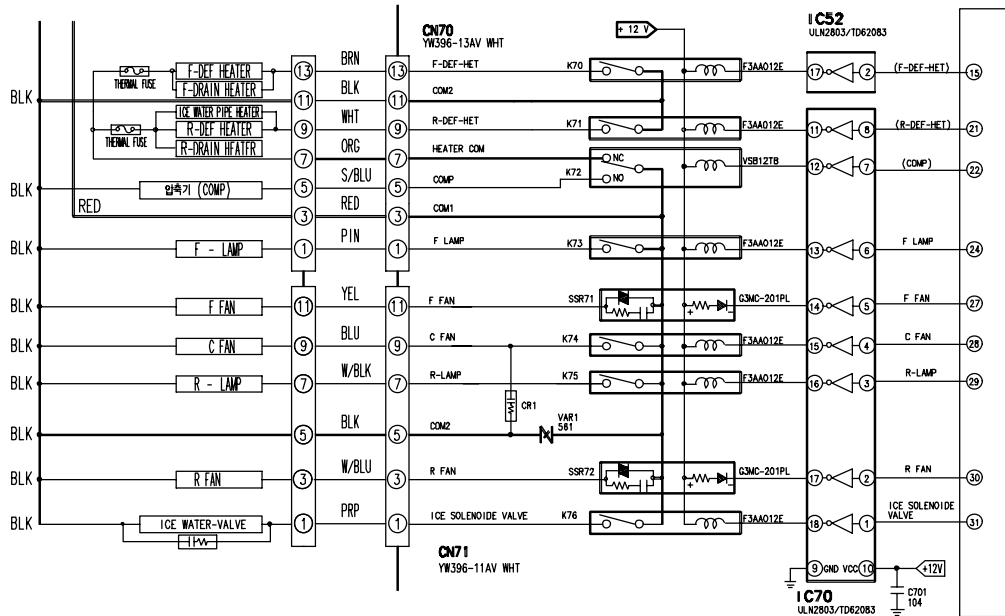

- 1) The main PCB processes most of the load control for electronic fridge.
- 2) Compressor, F-Room, defrost heater, and other functions are controlled by relays.
- 3) For example, to operate the compressor, MICOM Pin #22 outputs high (5V) signals which go into IC70 Pin #7. The IC70 Pin #7 plays the same role as the base of NPN TR. The Pin #12 works as the collector of TR. So, if 5V is supplied to the Pin #7 of IC70, the Pin #12 will be turned on and connected to the ground. Then, the relay K72 and the coil connected to the Pin #12 of IC70 becomes low (0V) and +12V (opposite side of coil) flows to the Pin #12 of IC70 via the coil and goes into the ground. While current flows to the coil, the magnetic power arises, it turns on the secondary contact point inside K72, and operates when the AC power is supplied to the both sides of the compressor. When MICOM Pin #22 becomes Low (0V), IC70 Pin #7 becomes Low which cuts out the power and the current of K72 RELAY. So, the secondary contact becomes off due to the magnetic field cut, which turns off the compressor. All other loads work based on the same principle. The defrost heater operates only if the compressor is turned off like the circuit above and it is connected like the equivalent circuit below.

- COMP & DEFROST HEATER EQUIVALENT

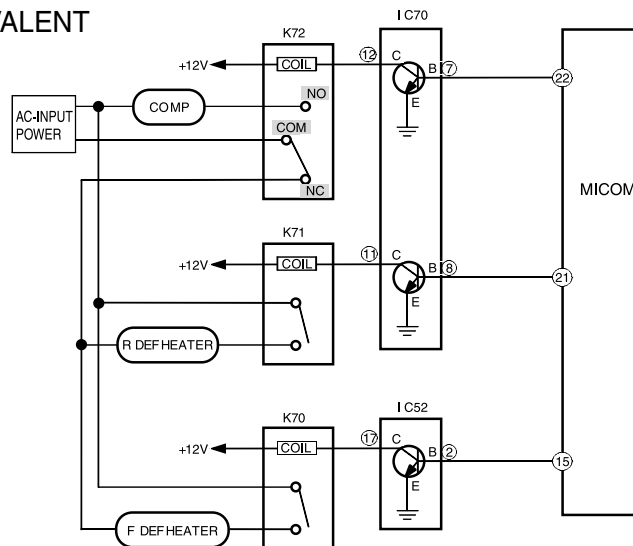

OPERATION PRINCIPLES BY PARTS OF CIRCUIT

11-10) Buzzer Circuit Diagram

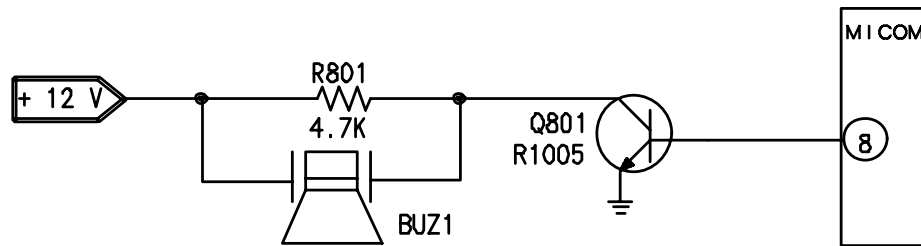

- 1) The circuit is composed of like the above and MICOM controls the alarm function with 2KHz. 12V is always applied to the circuit. So, when MICOM sends alarm signals to Q801 Transistor Base, the transistor is turned on applying 12V to the buzzer, which operates the buzzer. 4.7Kohm of R801 is a resistance for the production of quality buzzer sound.

12. DIAGNOSTICS

12-1) When power is not supplied	55
12-2) If there is a trouble with self-diagnosis	56
12-3) When COMP does not operate	59
12-4) When FAN does not operate	60
12-5) When Defrost does not operate	63
12-6) When Alarm Sound continues without stop	65
12-7) Panel PCB Defect	66
12-8) When Room Lamp does not light up(F &R Rooms are the same)	67
12-9) When Ice Water Valve does not operate (Option)	69
12-10) When Ice Maker does not operate (Option:Model installed)	70

Diagnostics

12-1) When power is not supplied

Pre-Check

1. Check if power is supplied at Concent and Power Cord is connected properly before repair
2. Check by referring to the followings.

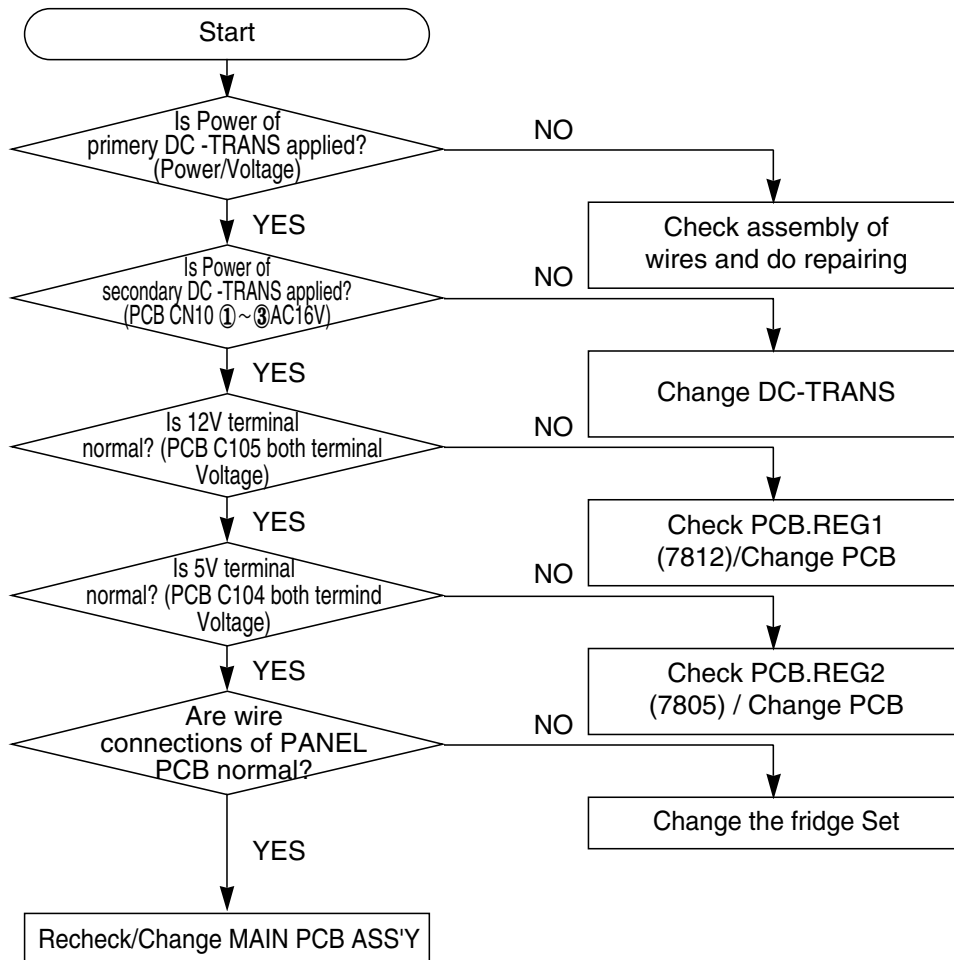

Diagnostics

12-2) If there is a trouble with self-diagnosis

1) Ambient Sensor trouble =>(applied to Ambient Sensor Temp type)

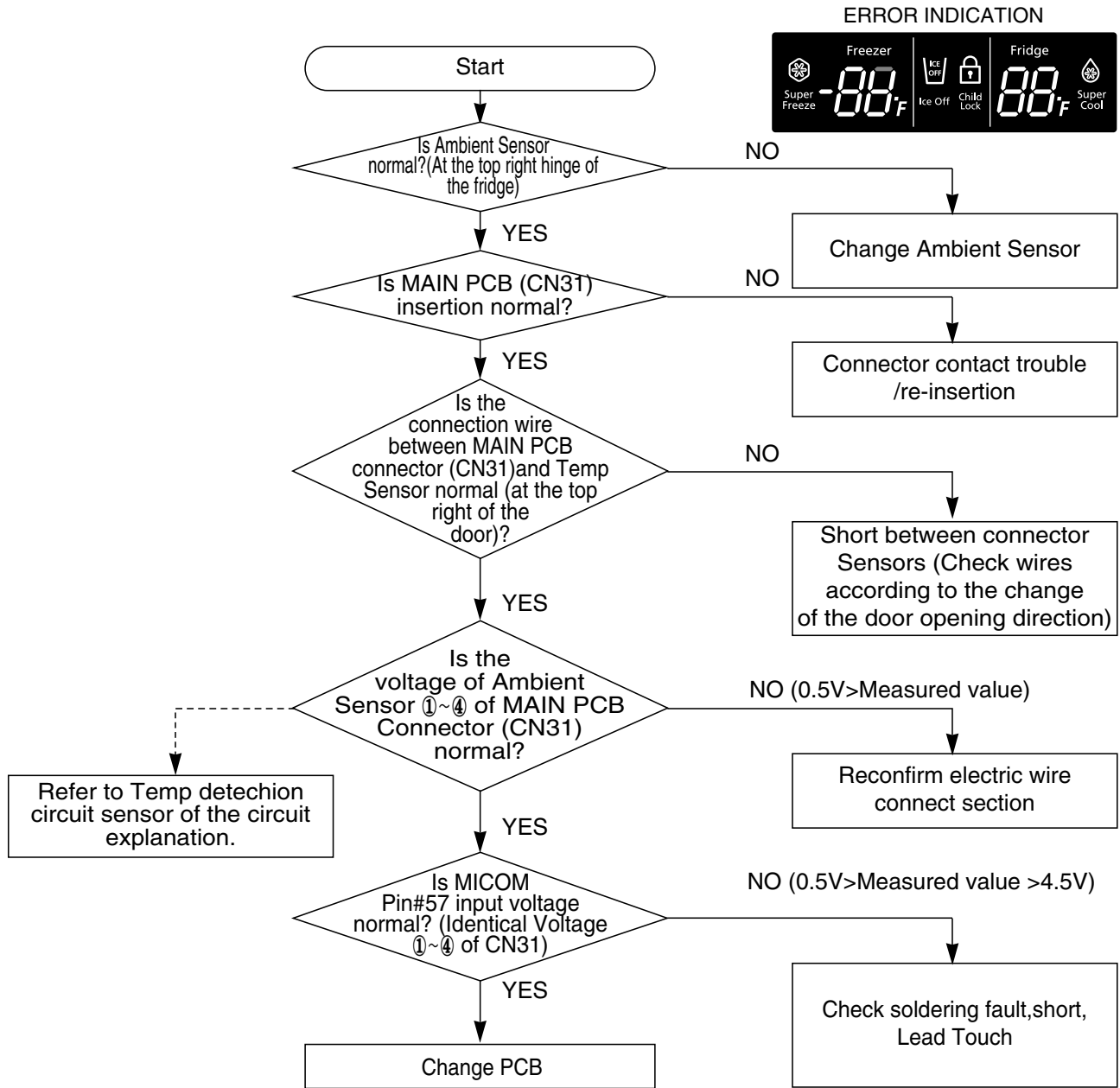

Diagnostics

2) R-Room Temp Sensor trouble

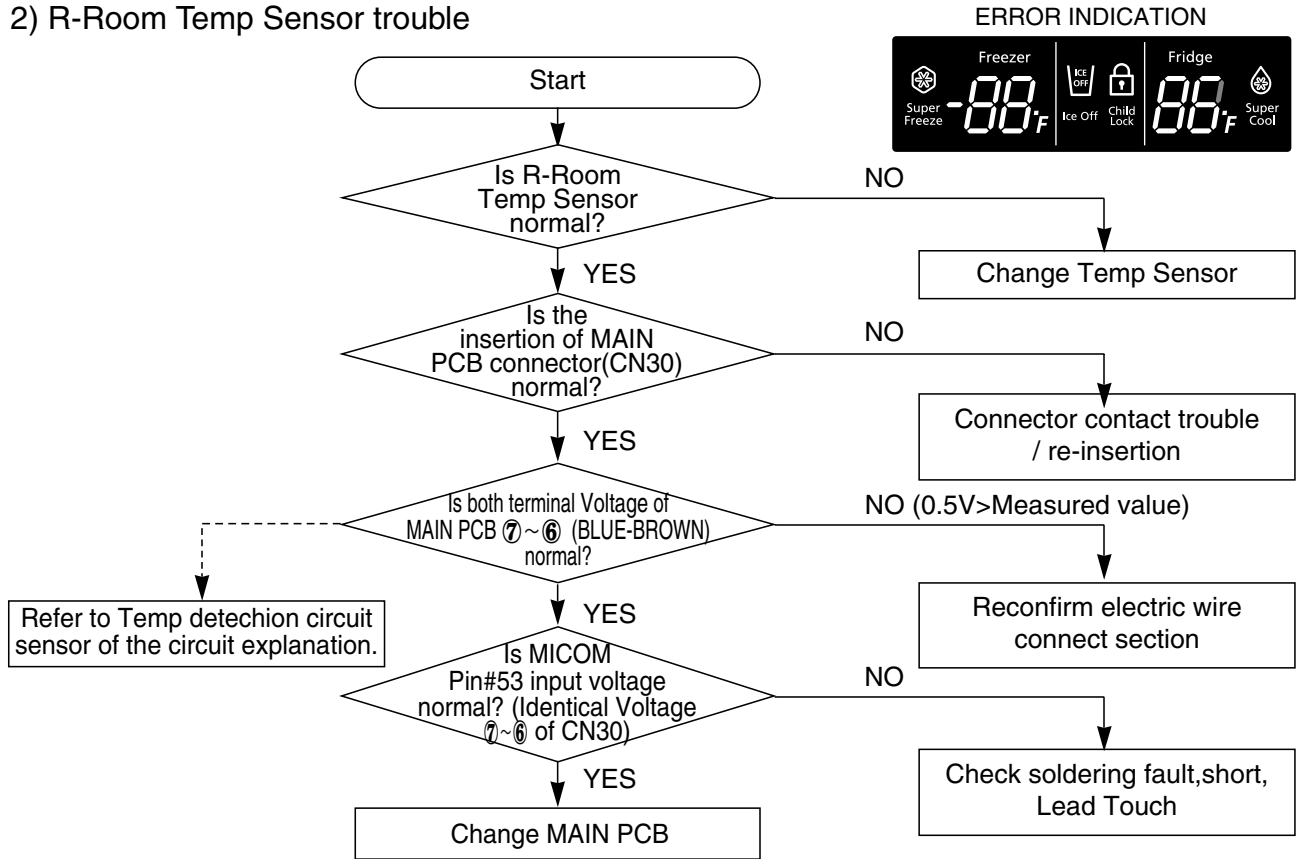

3) R-Room Defrost Sensor trouble

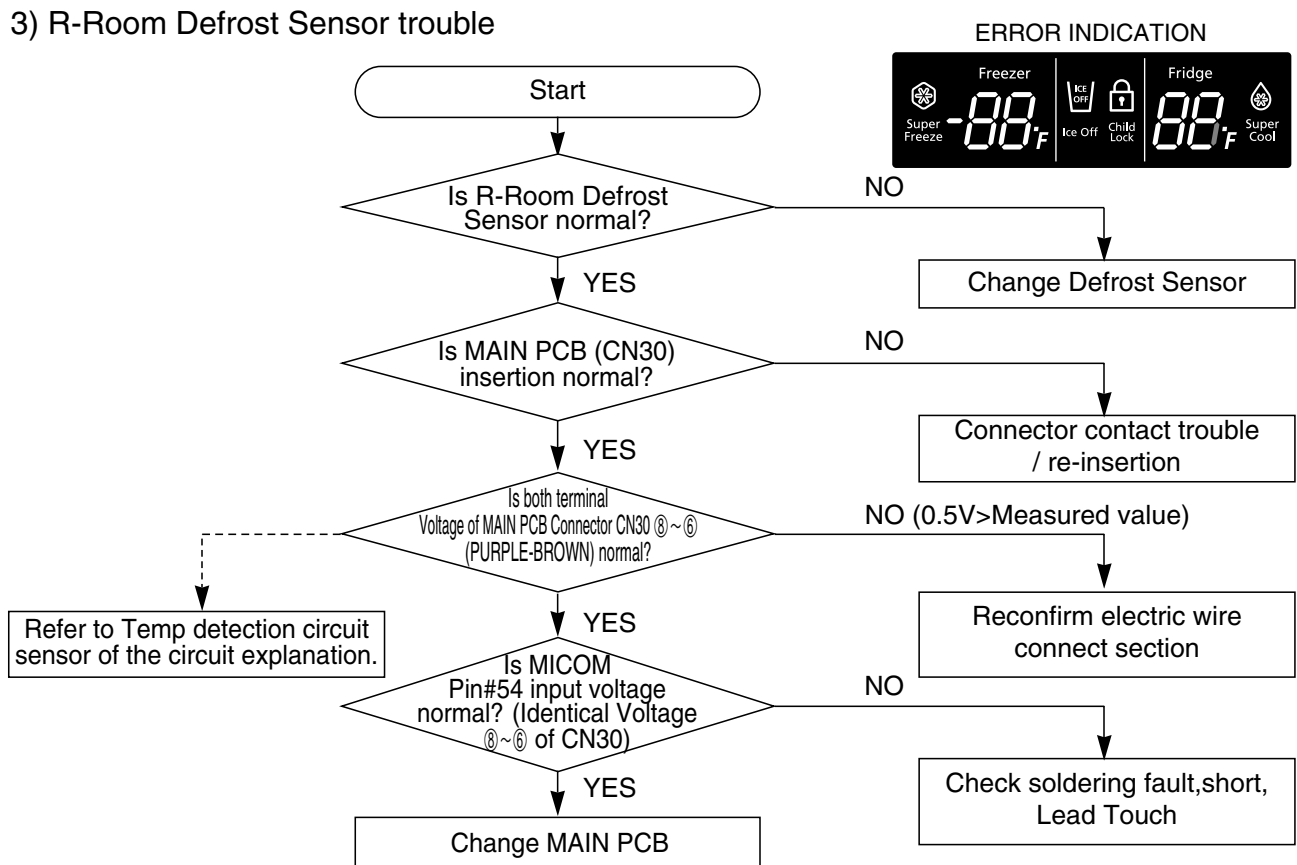

Diagnostics

4) F-Room Temp Sensor trouble

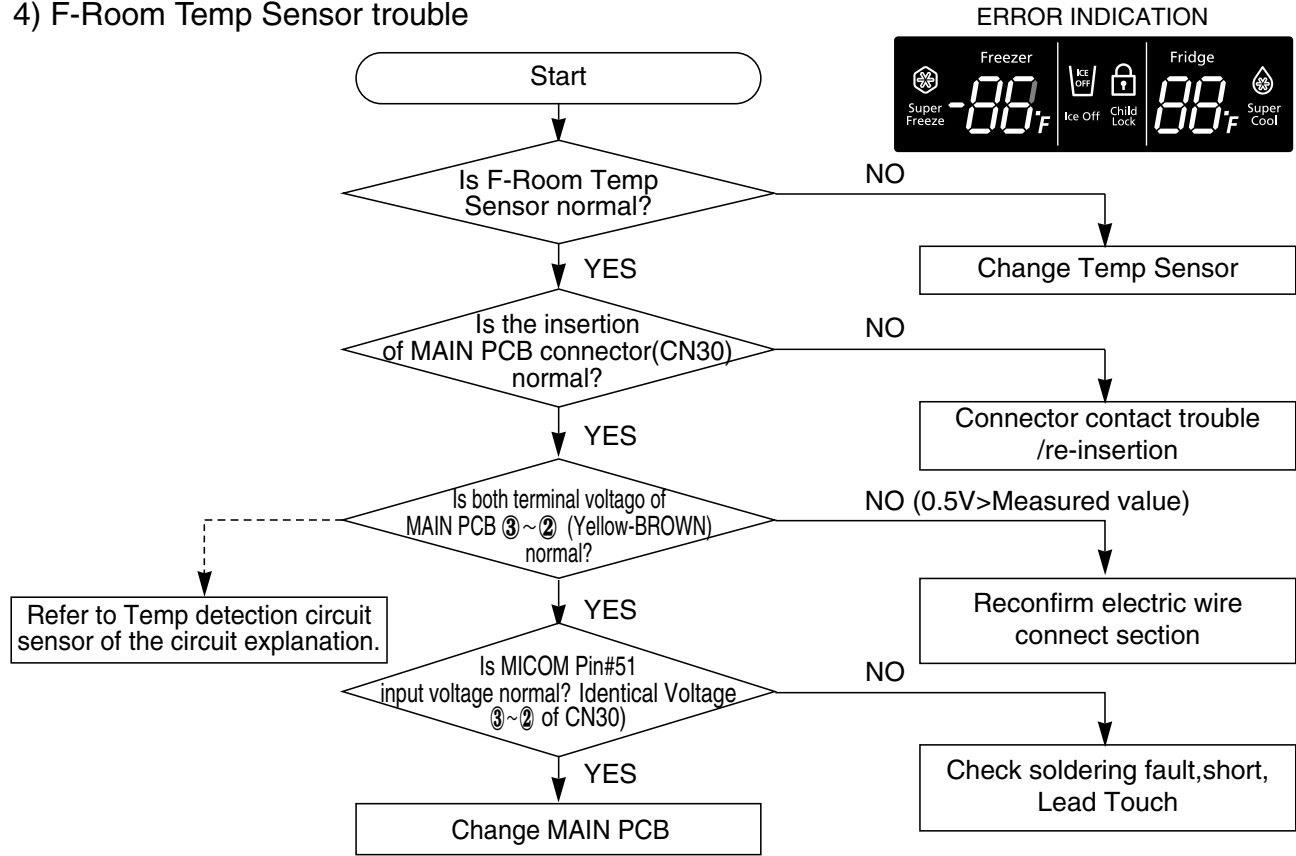

5) F-Room Defrost Sensor trouble

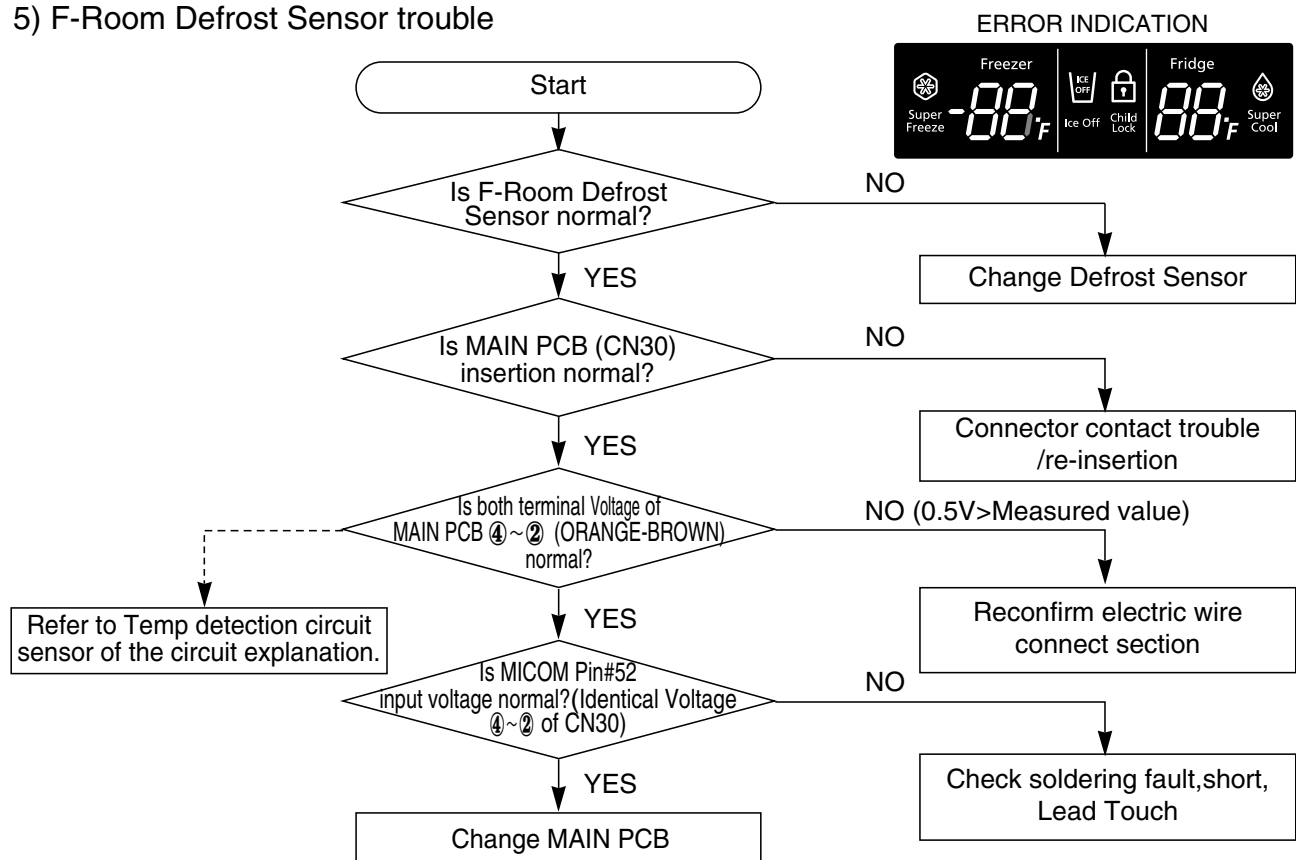

Diagnostics

12-3) When COMP does not operate

Pre-Check

“Check out the COMP with the Forced Operation selected”

1. If it does not pass 5 min after a desired Temp reached,COMP does not operate.
2. During Defrost,COMP does not operate.
3. With the disconnected F-Sensor or R-Sensor,COMP does not operate because low temperature is detected.

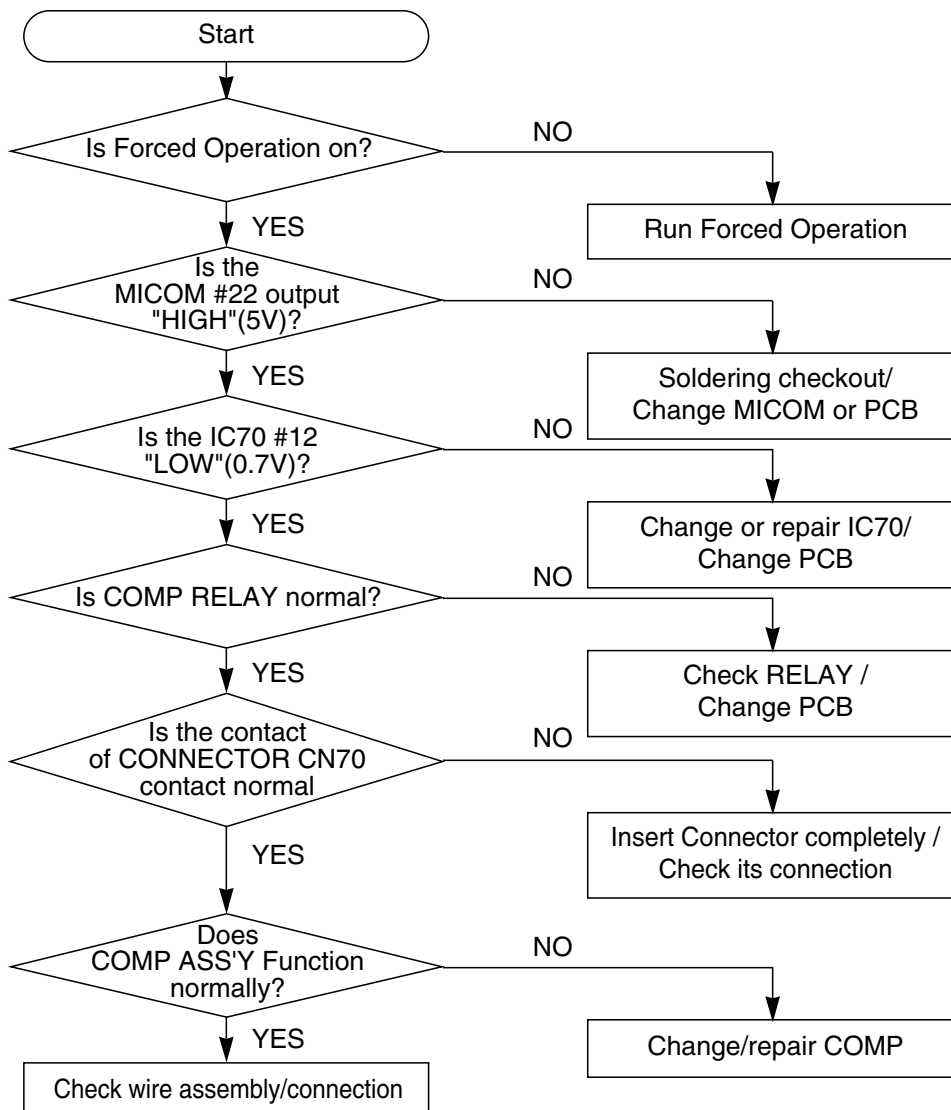

Diagnostics

12-4) When FAN does not operate

Note

"Check out the F-FAN with the Forced Operation selected"

1. F-Room FAN, R-Room FAN and COMP COOLING FAN remains OFF while COMP is off. (R-FAN can be on with the defrost function.)
2. When Comp is ON, R-FAN does not always remain ON (including Forced Operation) and when R-Room temp reaches to set temp, R-FAN remains OFF.
3. When R-Room & F-Room are closed after being opened, each FAN starts up with a delay time (5sec ~ 1min) immediately. (Comp ON condition)

1) When F-Room FAN(F-FAN) does not operate

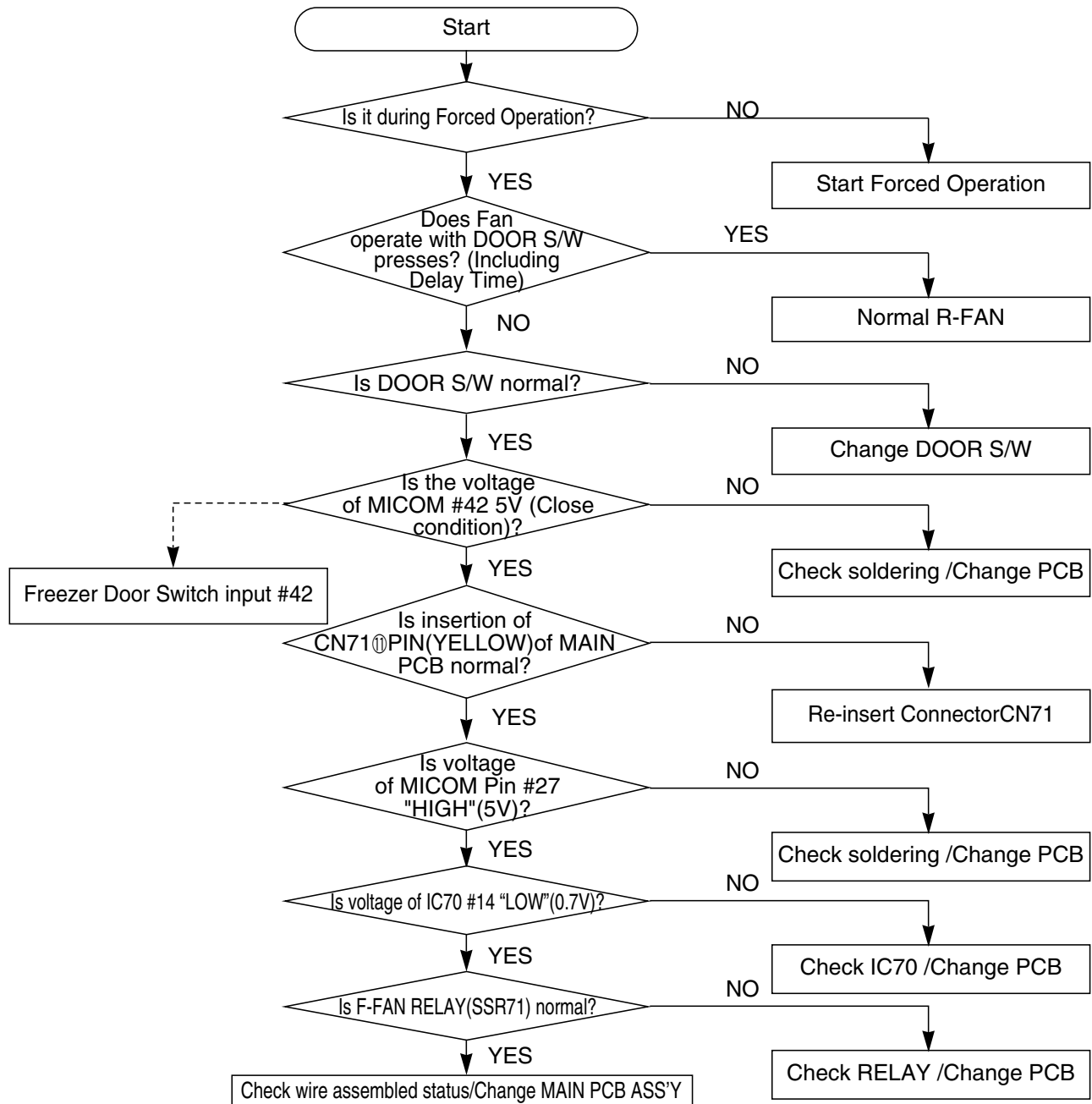

Diagnostics

2) When R-Room FAN(R-FAN)does not operate

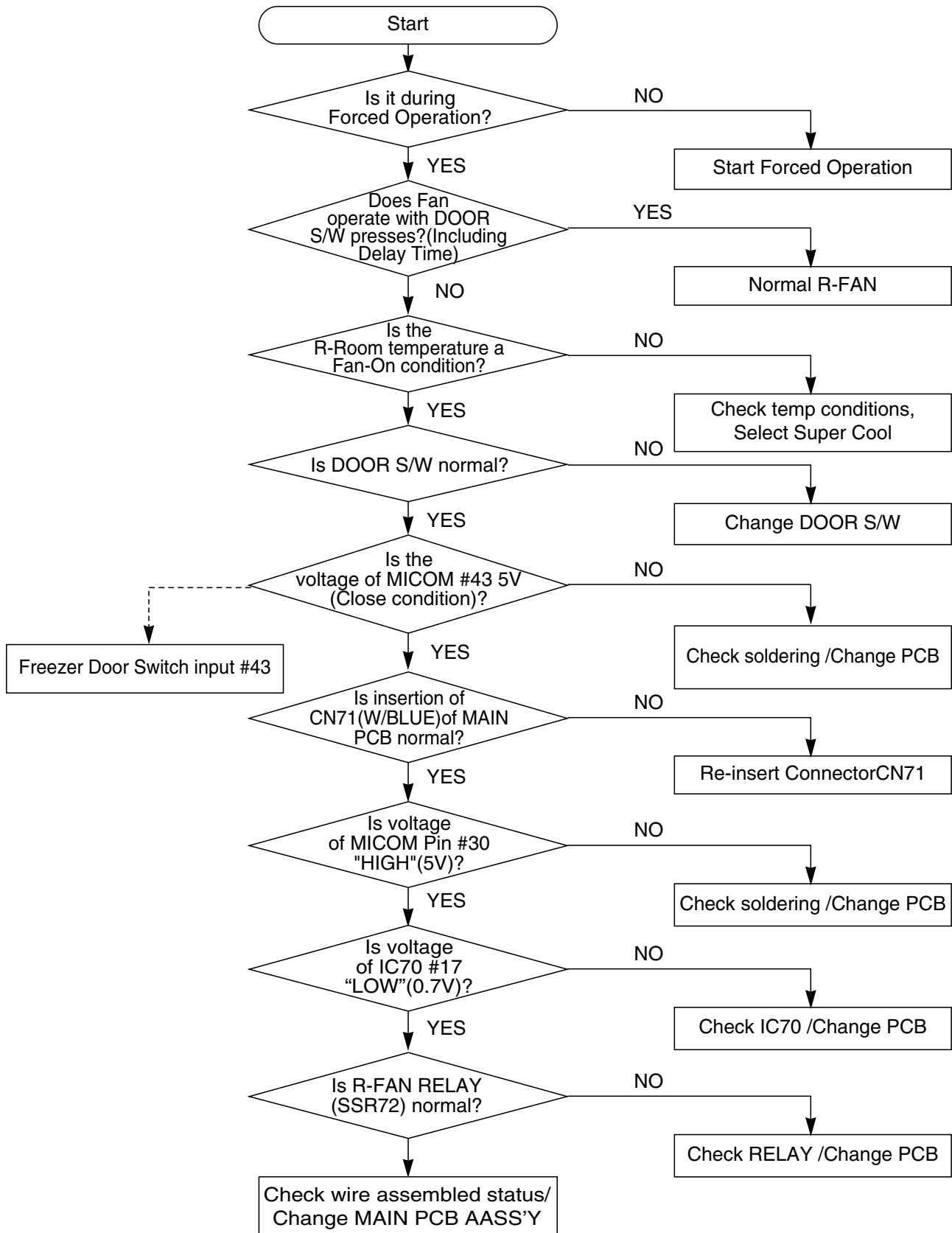

Diagnostics

3) When COMP COOLING FAN does not operate

Comp Fan operates immediately upon COMP ON
 Comp Fan operates in 3 min after COMP ON
 Comp Fan operates in 6 min after COMP ON
 Comp Fan operates in 9 min after COMP ON
 Comp Fan gets off regardless of COMP

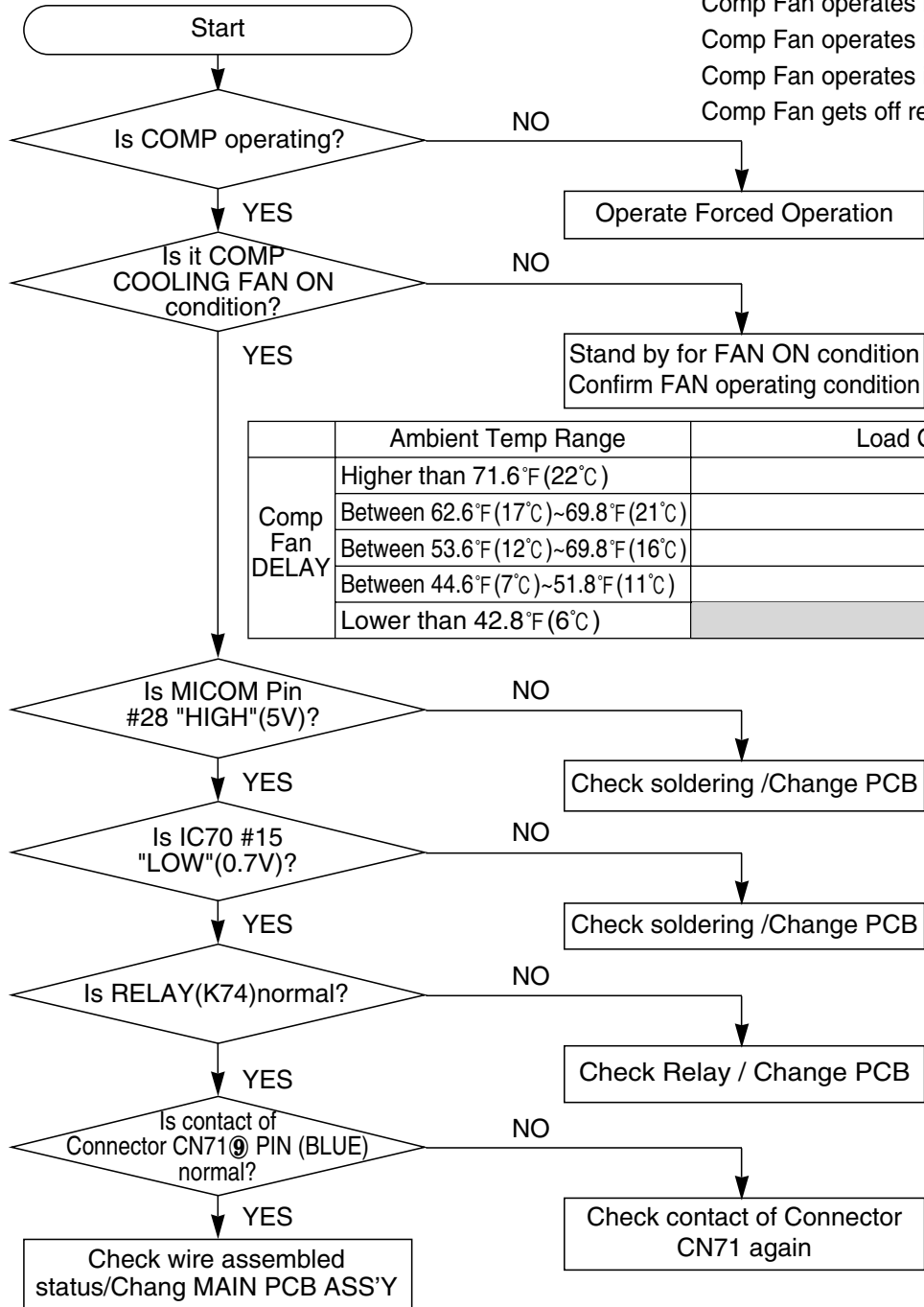

Diagnostics

12-5) When Defrost does not operate

Pre-Check

1. With a shorted-out F or R Defrost Sensor, the fridge operates normally excepting Defrost (The fault can be picked up with self-diagnosis, POWER ON/OFF).
2. There will be Heating trouble with a shorted-out Temp FUSE, which contributes to Defrost by natural Temp increase resulting in a Temp Control problem stemmed from the increased COMP OFF time.
3. When a F or R Defrost Sensor is faulty as OPEN, Heating will not be terminated, and COMP will remain off following the Temp FUSE short-off. (The fault can be picked up with self-diagnosis, POWER ON/OFF)

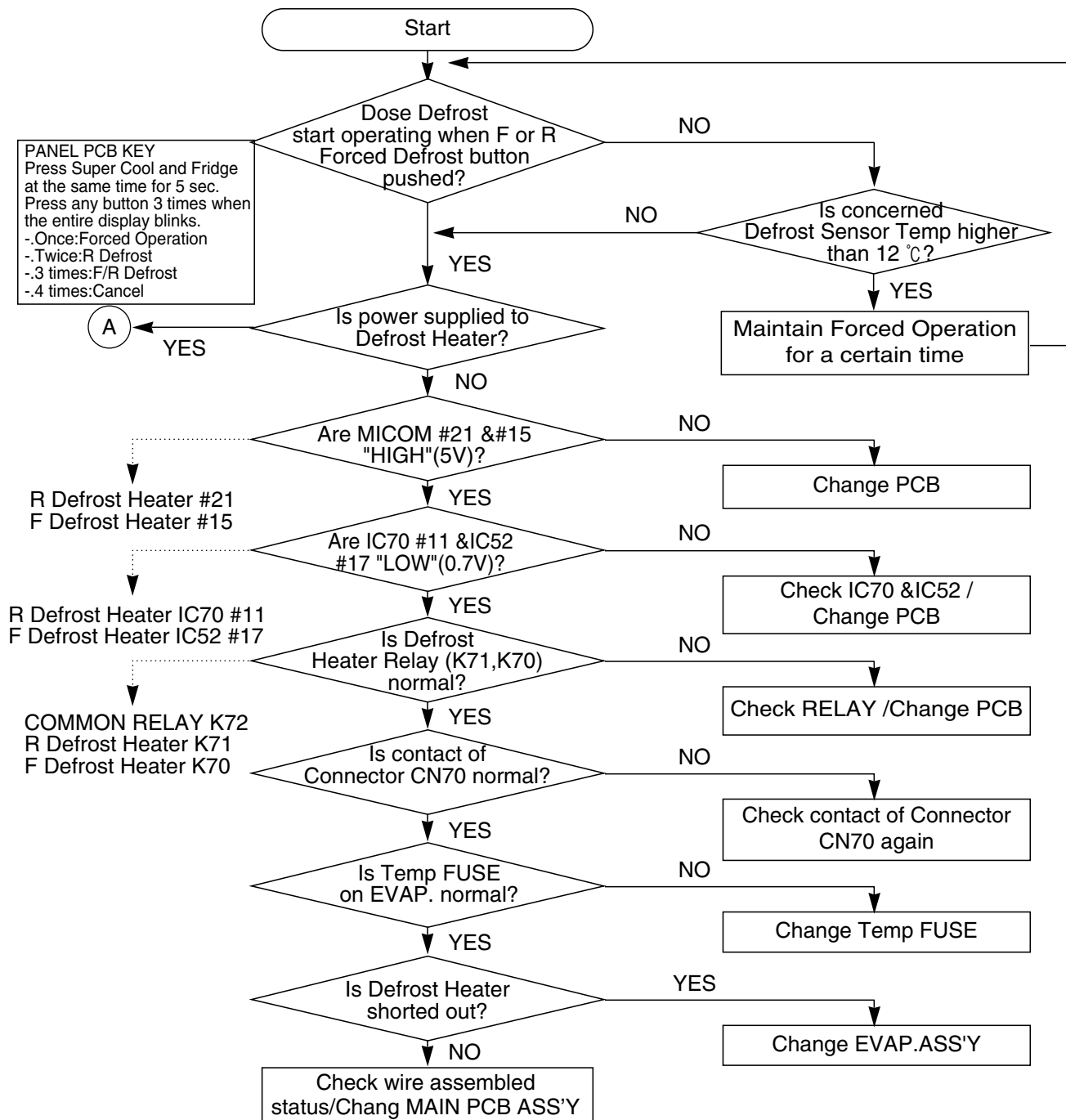

Diagnostics

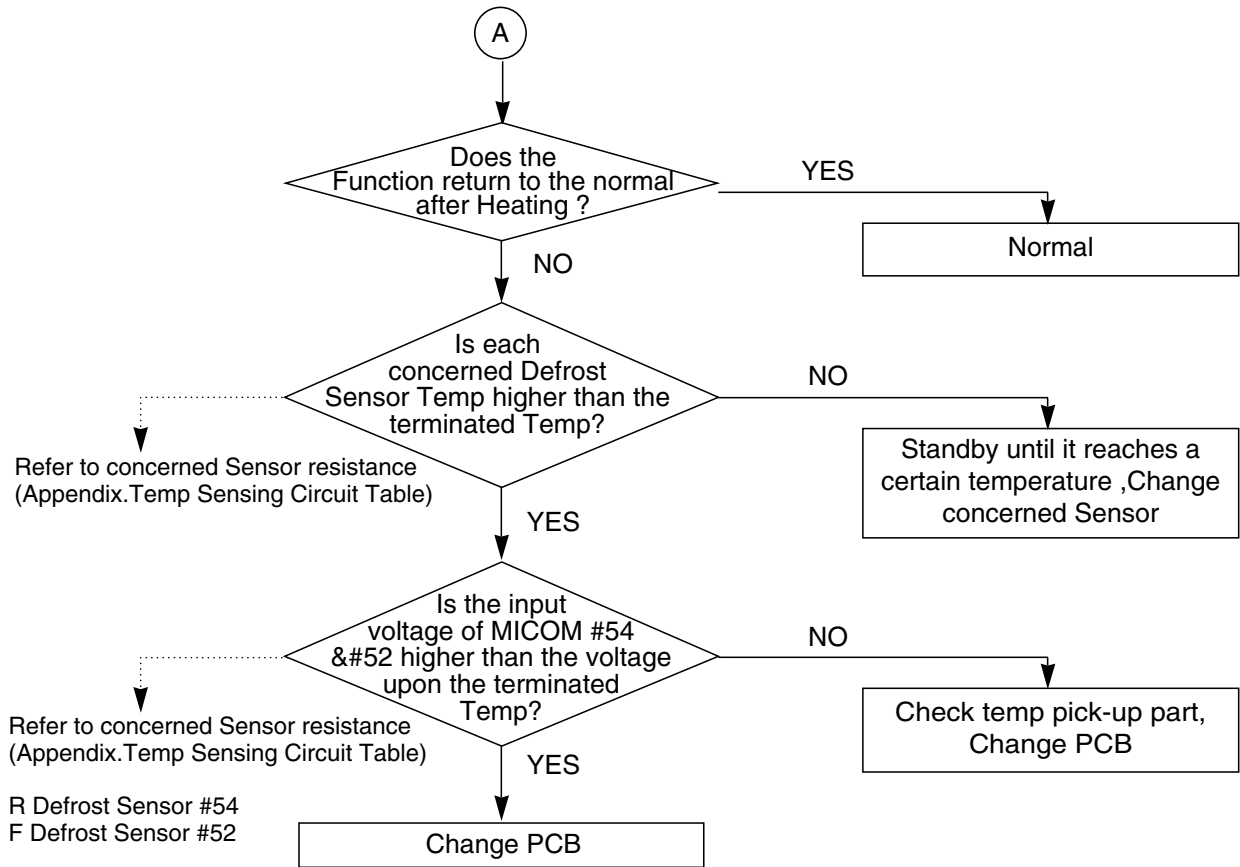

Diagnostics

12-6) When Alarm Sound continues without stop

Note

1. When Door gets open, Door Open alarm ("Ding Dong") goes off in 2 minutes with Door opened. When Door remains open after this, the alarm goes off every minute.
2. When Door Switch is not pressed well, MICOM considers it as opened and alarming sound goes off. Room Lamp becomes OFF in 10 minutes since it detects Door Open. In this case, even though Door gets opened, Room Lamp does not come ON.

1) If melody sounds continuously

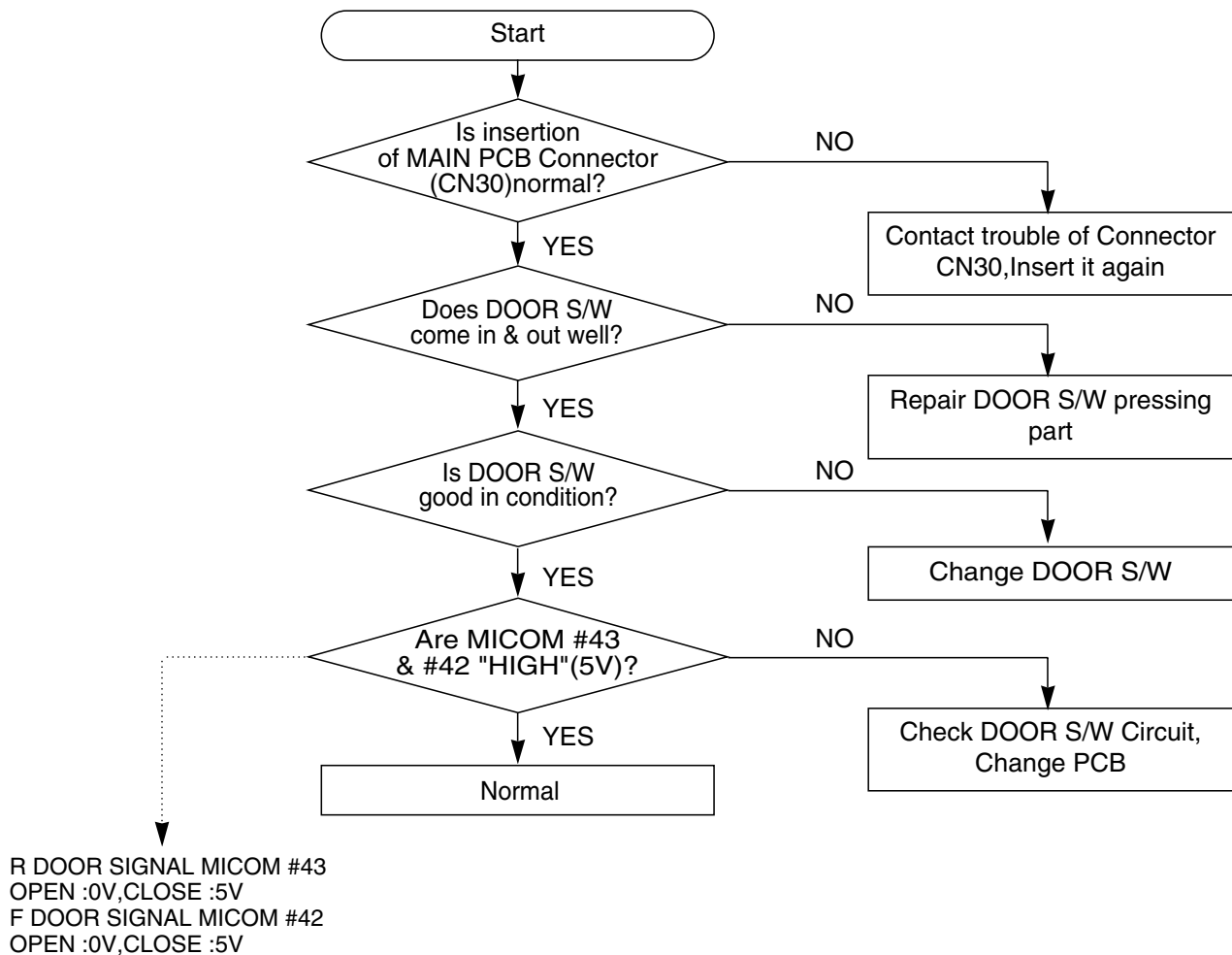

Diagnostics

2) When "Beep Beep" sound continues

Note

1. "Beep-Beep" sounds do not go off except Forced Operation & Forced Defrost.
2. It is checkable at Panel PCB when Forced Operation or Forced Defrost is selected, so when error occurs, check it and correct the error.

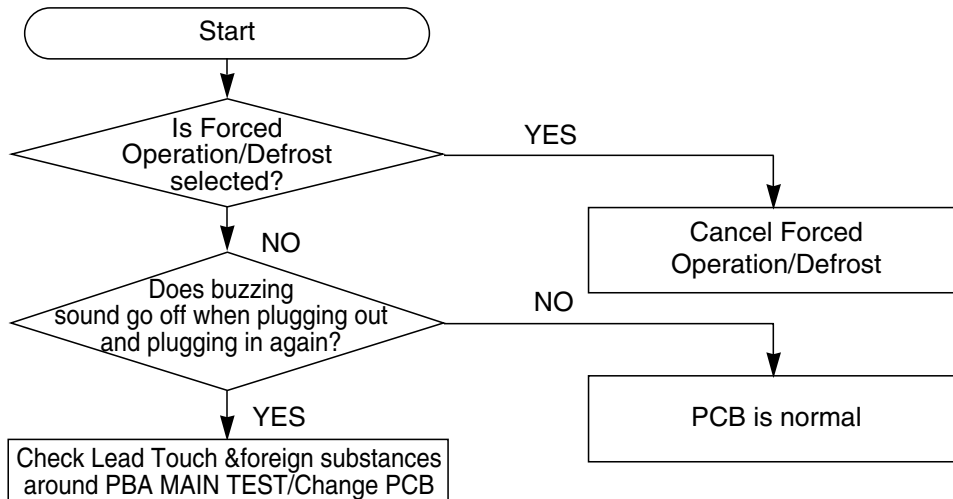

12-7) Panel PCB Defect

1) When PANEL PCB doesn't light up

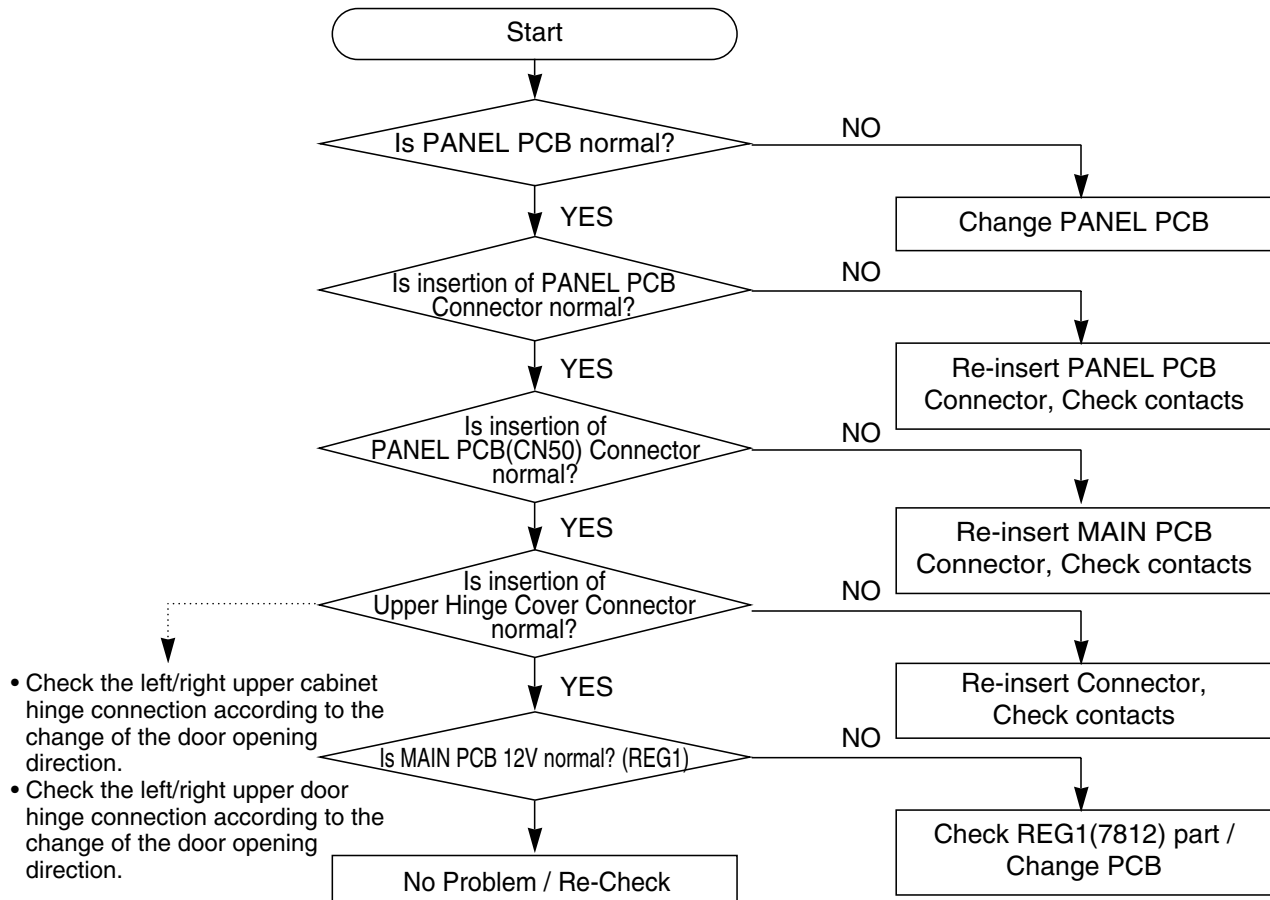

Diagnostics

2) When PANEL PCB Buttons do not work

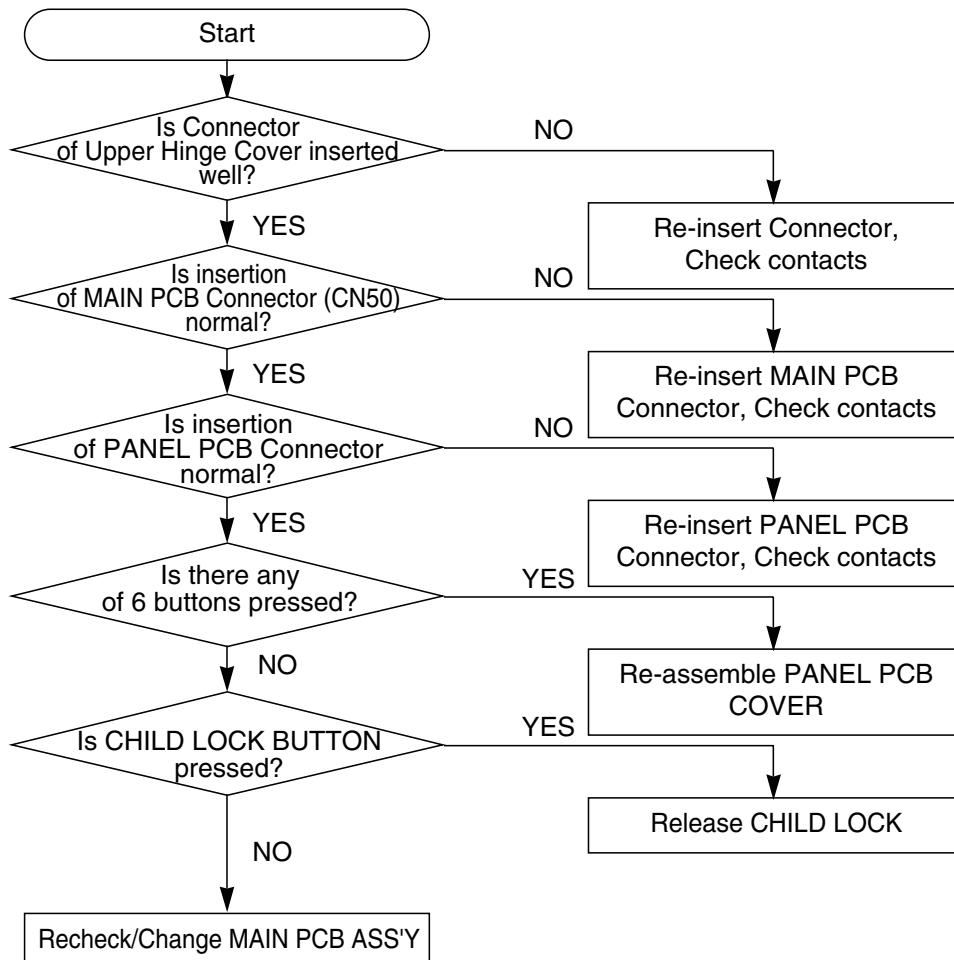

12-8) When Room Lamp does not light up(F &R Rooms are the same)

1) When F &R Room Lamps do not light up

Pre-Check

- Room Lamp(F,R)
- 1. Check F-Room Lamp ON after opening Freezer Door.
- 2. Check F-Room Lamp OFF by pushing Door S/W.
- 3. Check R-Room with using the same method ①,② after closing Freezer Door.
- 4. When it's problems, check Room Lamp and Door S/W (Refer to Door S/W sensor circuit)
- 5. Check the electric wire connect status.

Diagnostics

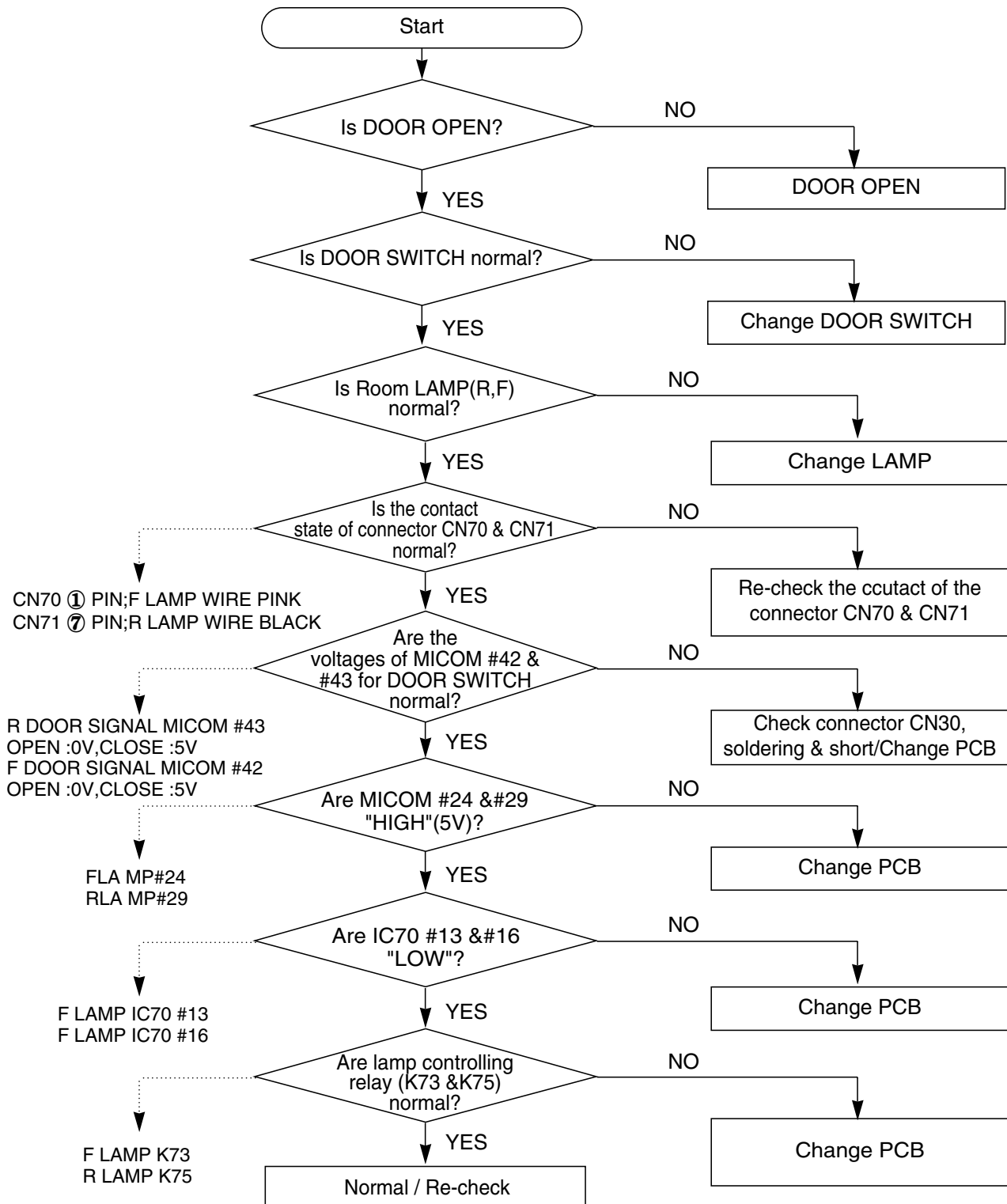

12-9) When Ice Water Valve does not operate (Option)

Pre-Check

1. While disassembling, make sure to cut off water since the ice water valve is directly connected with water.
2. Make sure to avoid the electric shock while disassembling because one end of wire is applied with power.
3. Check the operation of the ice water valve only after the ice maker test switch is pressed.
(F-Room Ice Maker)

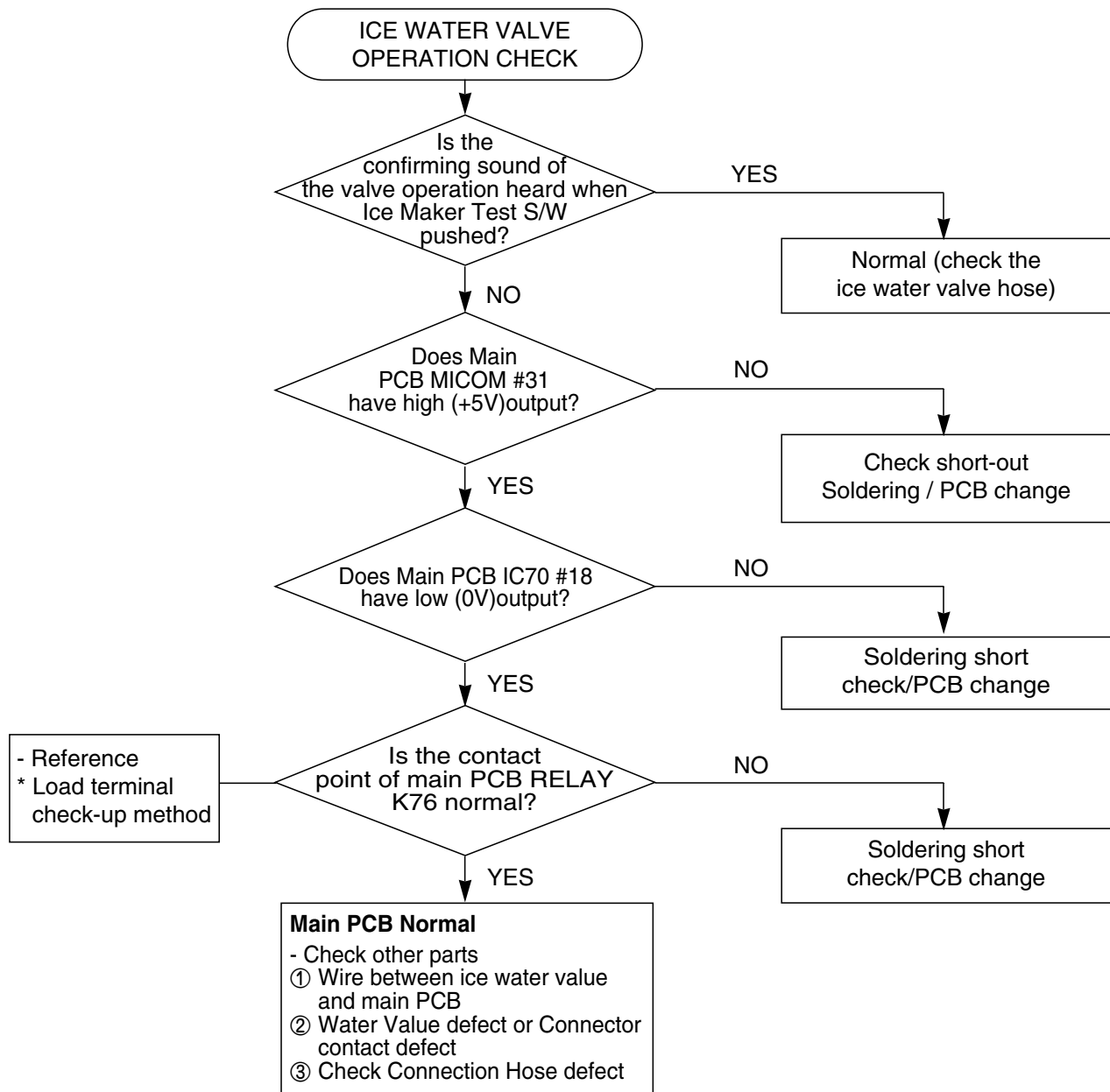

12-10) When Ice Maker does not operate (Option:Model installed)

Pre-Check

1. Water is automatically supplied to the Ice Maker and it dispenses cubed or crushed ice according to its setting.
2. Power is applied to one of its wires. So, be sure to refer to its exploded view when disassembling.
3. To check the operation of the Ice Maker, press the Ice Maker Test S/W. (F-Room Ice Maker) It is not possible to check with the power disengaged.

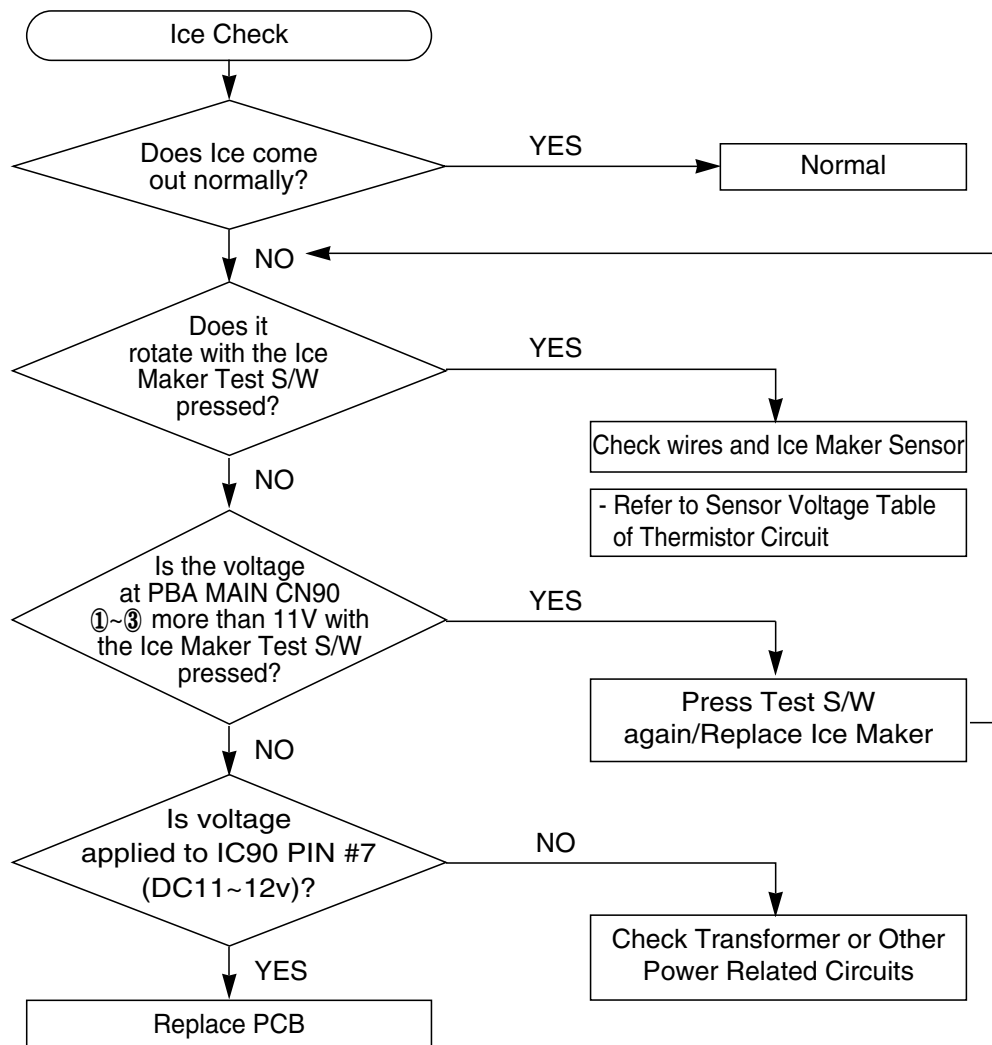

13 . Illustrated Parts Catalog.

13-1) Freezer

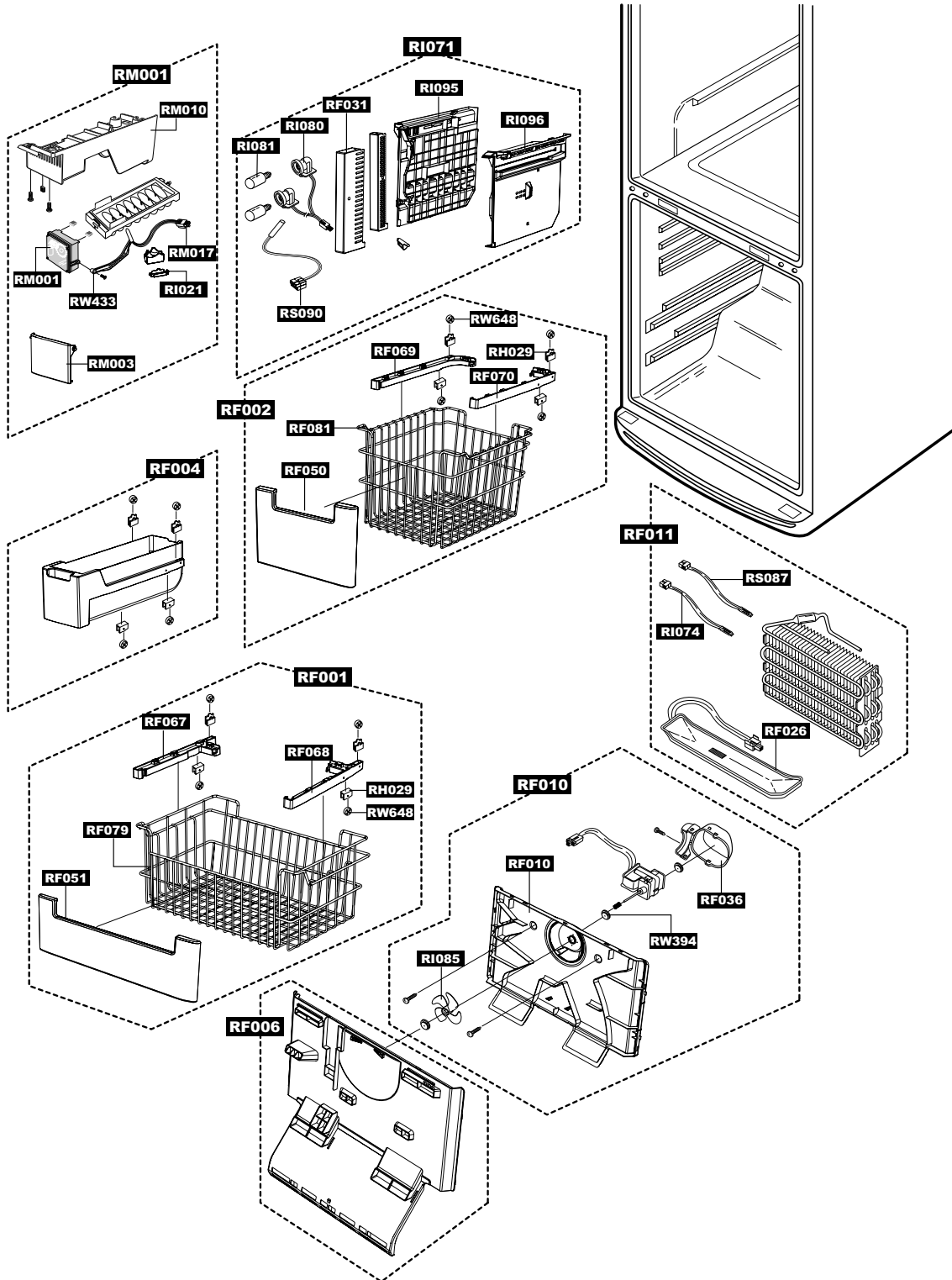

Illustrated Parts Catalog.

13-2) Fridge

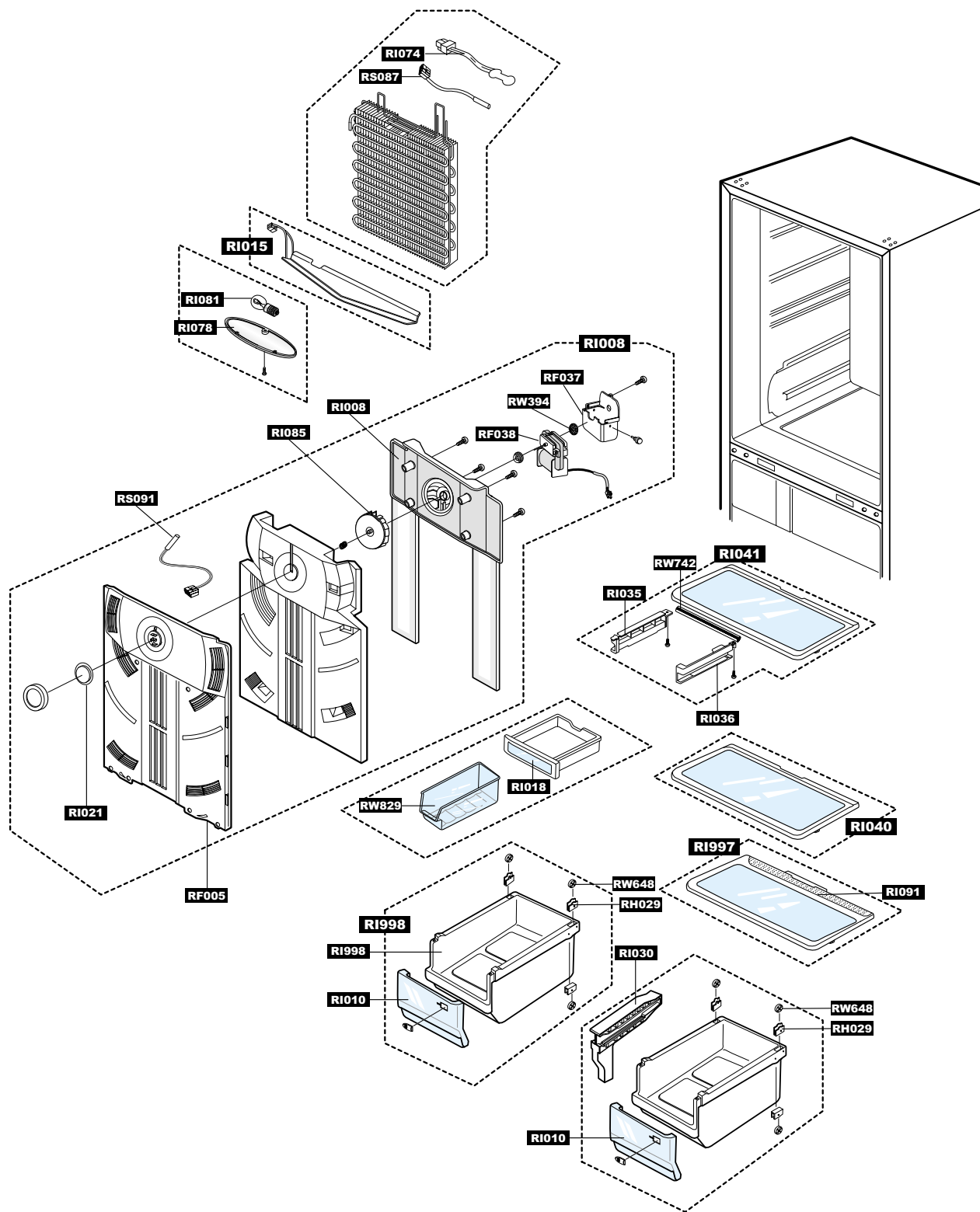

Illustrated Parts Catalog.

13-3) Door of Fridge

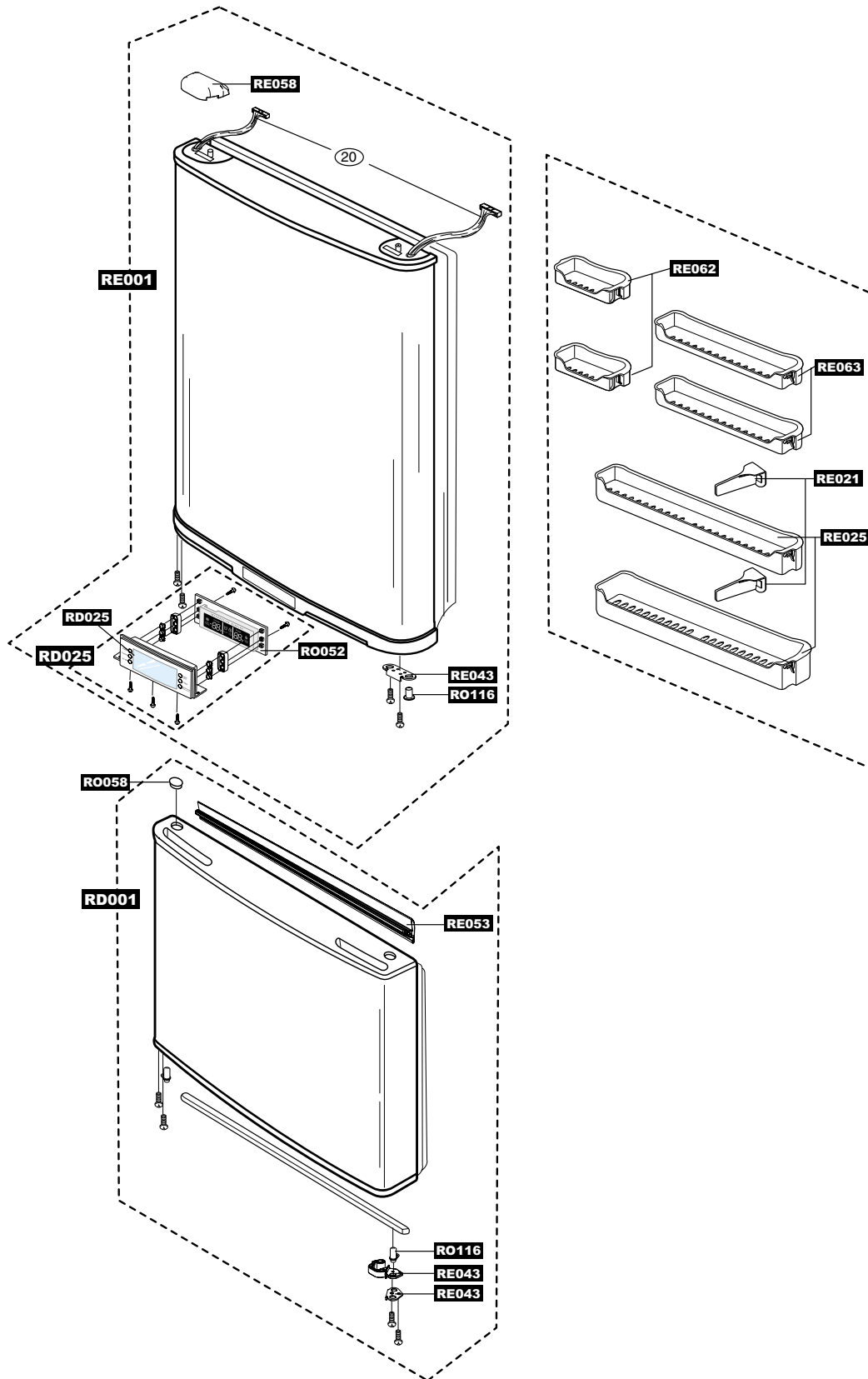

Illustrated Parts Catalog.

13-4) Cabinet

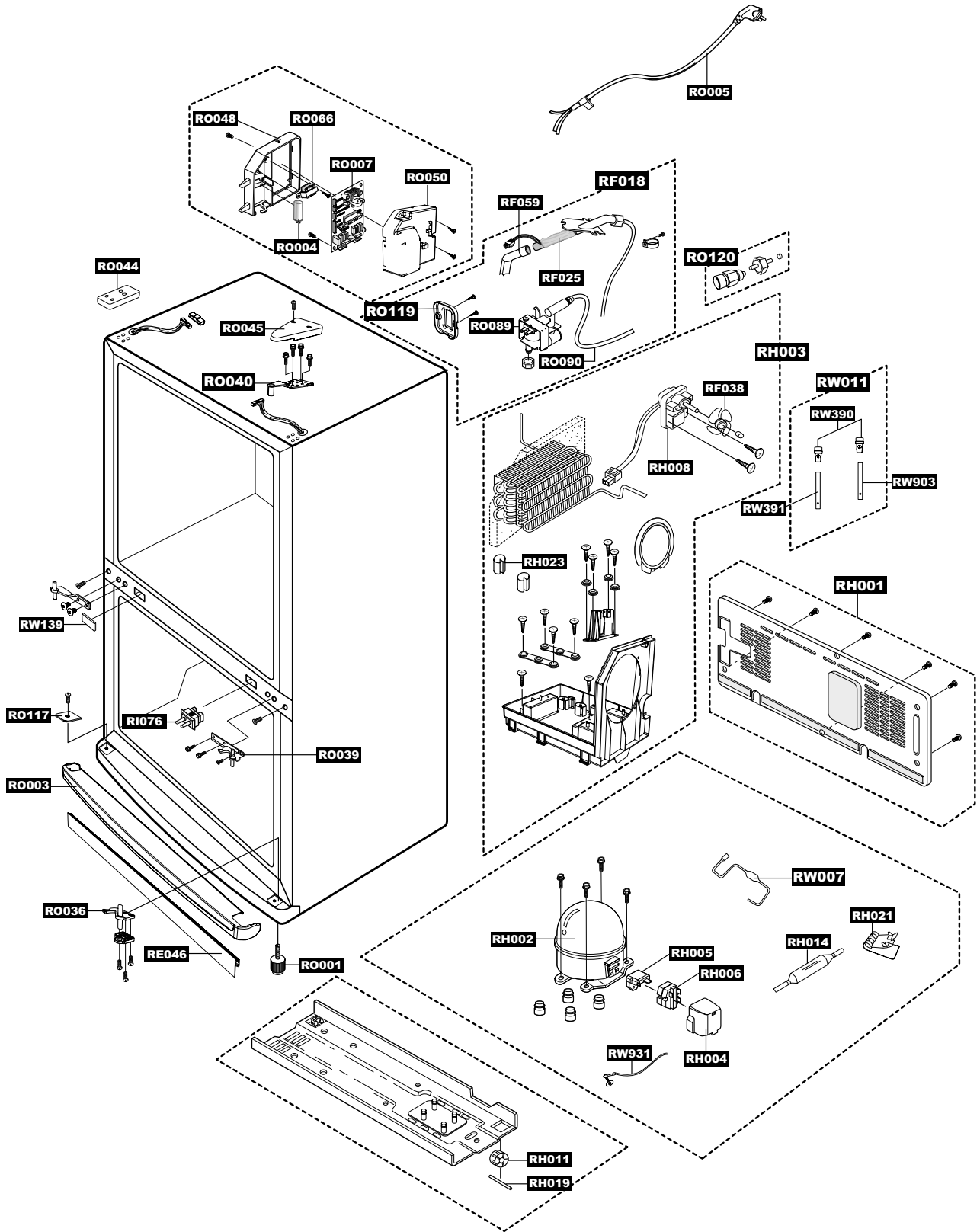

SAFETY PRECAUTIONS FOR AS

- Upon electronic Control system repair/change,make sure the set unplugged.
 - ⇒ Be ware of electric shock.
- Use rated electronic Control equipment.
 - ⇒ Make sure to check out ModeL name,Rated voltage,Rated current,Operation Temp,etc.
- Upon repair,make sure that harnesses are not to be water-penetrated and are bundled tight.
 - ⇒ Should not be detached by a certain amount of external force.
- Upon repair,completely remove dust or other foreign substances from housing,harness, connector,etc.
 - ⇒ To prevent fire by tracking,short,etc.
- Check out whether water has penetrated into the electronic Control system.
 - ⇒ If there is any kind of trace,take necessary measures such as related component change, insulation tapping,etc.
- After repair,check out the assembled state of parts.
 - ⇒ It should be the same as the previous state.
- Check out the surrounding conditions.
 - ⇒ Change the location,if the fridge is located at humid,wet places or the installed state is unstable.
- If needed,ground the fridge.
 - ⇒ Especially,if there is a possibility of electric leakage,ground is indispensable.
- Do not allow consumers to overload a certain outlet.
- Check out whether the power cord or the outlet is broken,squeezed,chopped off or heat-deformed.
 - ⇒ Repair or replace the defective power cord/outlet immediately.
 - ⇒ Make sure the power cord is not punctuated or stomped down.
- Do not allow consumers to keep food unstable or place bottles in the Freezer Room.
- Do not allow consumers to repair the fridge for themselves.
- Do not allow consumers to keep things except for food.
 - ⇒ Pharmaceutical,Chemical substances :These are not possible to be fine-Controlled with a consumer fridge.
 - ⇒ Flammable material (alcohol,benzene,ether,LPG,etc):possibility of explosion.

14. REFERENCE

14-1) Reference (Measure Load Terminals)

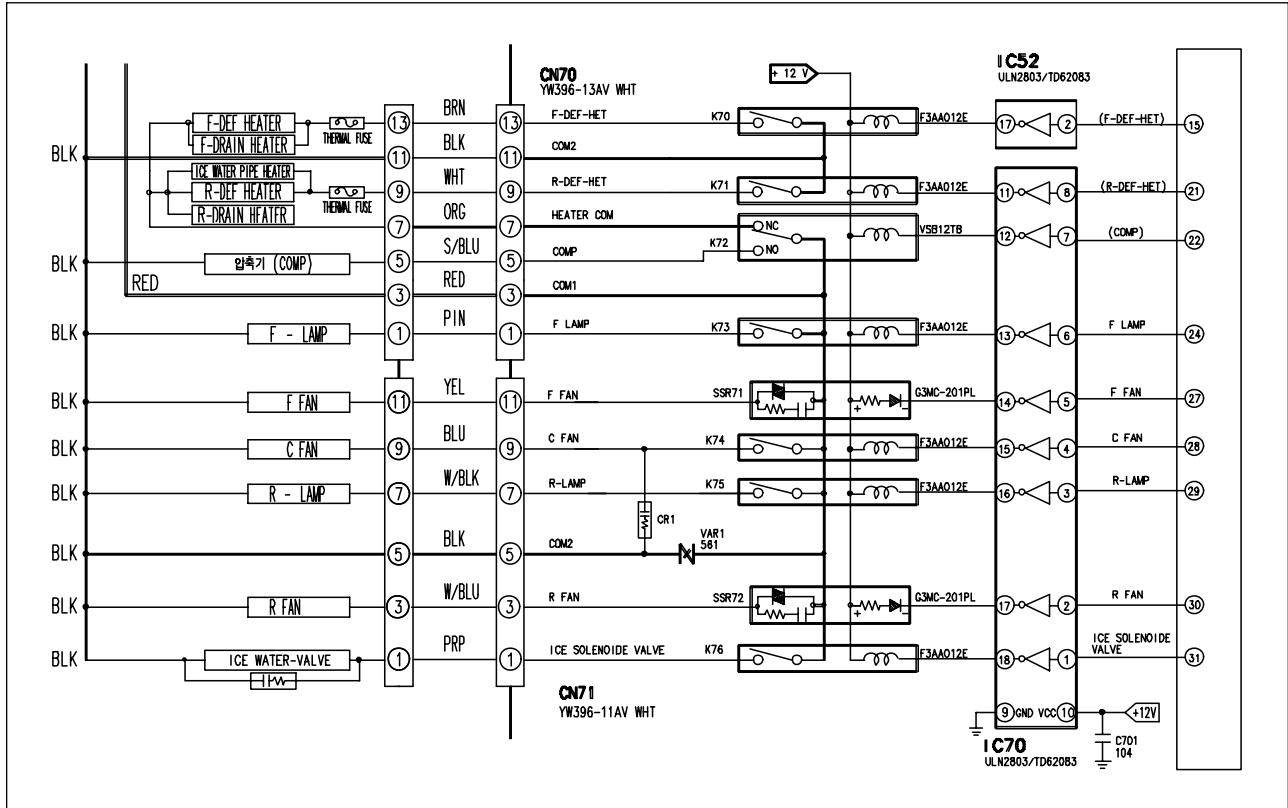

* Turn off Power, disassemble Housing connected to MAIN PCB CN70,71 and measure followings

LOAD	MEASURING TERMINALS PCB MAIN	VALUE	DEFECTS	OTHERS
1) F DEFROST HEATER 2) F DRAIN HEATER	CN70 ⑬ & ⑦	0 Ω	THERMAL FUSE, HEATER, WIRE SHORT	VALUE FOR NORMAL HETAER
		∞ Ω	THERMAL FUSE, HEATER, WIRE CUT	
1) R DEFROST HEATER 2) ICE WATER PIPE HEATER	CN71 ⑨ & ⑦	0 Ω	THERMAL FUSE, HEATER, WIRE SHORT	VALUE FOR NORMAL MOTOR
		∞ Ω	THERMAL FUSE, HEATER, WIRE CUT	
ICE WATER VALVE	CN71 ① & ⑤	0 Ω	COIL, WIRE SHORT	VALUE FOR NORMAL MOTOR
		∞ Ω	COIL, WIRE CUT	
F FAN MOTOR	CN71 ⑪ & ⑤	0 Ω	MOTOR, WIRE SHORT MOTOR, WIRE	VALUE FOR NORMAL MOTOR
		∞ Ω	CUT, HOUSING SLIPPED AWAY	
R FAN MOTOR	CN71 ③ & ⑤	0 Ω	MOTOR, WIRE SHORT MOTOR, WIRE	VALUE FOR NORMAL MOTOR
		∞ Ω	CUT, HOUSING SLIPPED AWAY	
COMP. FAN MOTOR	CN71 ⑨ & ⑤	0 Ω	MOTOR, WIRE SHORT MOTOR, WIRE	VALUE FOR NORMAL MOTOR
		∞ Ω	CUT, HOUSING SLIPPED AWAY	
R LAMP	CN71 ⑦ & ⑤	0 Ω	LAMP, WIRE SHORT LAMP, WIRE	VALUE FOR NORMAL MOTOR
		∞ Ω	CUT, HOUSING/LAMP SLIPPED AWAY	
F LAMP	CN70 ① & ⑪	0 Ω	LAMP, WIRE SHORT LAMP, WIRE	VALUE FOR NORMAL MOTOR
		∞ Ω	CUT, HOUSING/LAMP SLIPPED AWAY	

* Turn on Power and check status of Relay & Driving Circuit by checking followings according to load operation .

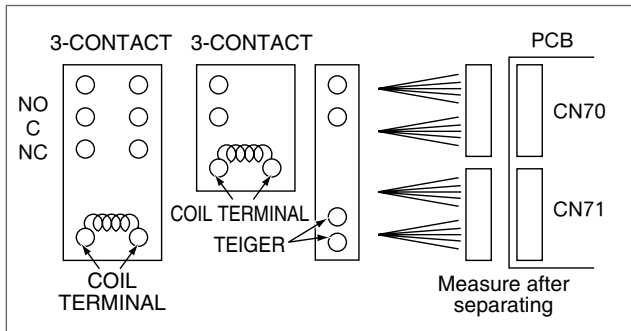

Note) NC →NORMAL CLOSE
(C-TERMINAL & ON-TERMINAL)
NO →NORMAL OPEN
(C-TERMINAL & OPEN-TERMINAL)
C →COMMON TERMINAL

OPERATION	RELAY	TERMINALS	VALUE	WHEN IT IS DIFFERENT FROM MEASURED VALUE
R,F DEFROST & COMP OFF	K70	CN70 ⑪-⑬	SUPPLY VOLTAGE (SV)	K70 CONTACT SHORT,FAULTY DRIVING CIRCUIT
	K71	CN70 ⑪-⑨	SV	K71 CONTACT SHORT,FAULTY DRIVING CIRCUIT
	K72	CN70 ⑤-③	SV	K72 NO CONTACT SHORT,FAULTY DRIVING CIRCUIT
COMP ON	K70	CN70 ⑪-③	5~30V	FAULTY K70 OR K72 NC CONTACT SHORT,FAULTY DRIVING CIRCUIT
	K71	CN70 ⑪-⑨	5~30V	FAULTY K71 OR K72 NC CONTACT SHORT,FAULTY DRIVING CIRCUIT
	K72	CN70 ⑤-③	0V	K72 NO CONTACT OPEN,FAULTY DRIVING CIRCUIT
R DEFROST ON	K71	CN70 ⑪-⑨	0V	FAULTY K71,K72 NC CONTACT OPEN,FAULTY DRIVING CIRCUIT
	K72	CN70 ⑤-③	SV	K72 NO CONTACT SHORT,FAULTY DRIVING CIRCUIT
F DEFROST ON	K70	CN70 ⑬-⑨	0V	K70 CONTACT SHORT,FAULTY DRIVING CIRCUIT
	K72	CN71 ⑤-③	SV	K72 NO CONTACT SHORT,FAULTY DRIVING CIRCUIT
F FAN ON R FAN	SSR71	CN71 ⑪-CN70 ③	0V	SSR71 OPEN,FAULTY DRIVING CIRCUIT
ON C FAN ON	SSR72	CN71 ③-CN70 ③	0V	SSR72 OPEN,FAULTY DRIVING CIRCUIT
ICE WATER	K74	CN71 ⑨-CN70 ③	0V	K74 NO CONTACT OPEN,FAULTY DRIVING CIRCUIT
VALVE ON R	K76	CN71 ①-CN70 ③	0V	K76 NO CONTACT SHORT,FAULTY DRIVING CIRCUIT
LAMP ON	K75	CN70 ①-③	0V	K75 NO CONTACT OPEN,FAULTY DRIVING CIRCUIT(DOOR SWITCH)
F LAMP ON	K73	CN71 ⑦-CN70 ③	0V	K73 NO CONTACT SHORT,FAULTY DRIVING CIRCUIT(DOOR SWITCH)

14-2 Reference (Measure Sensor Terminals)

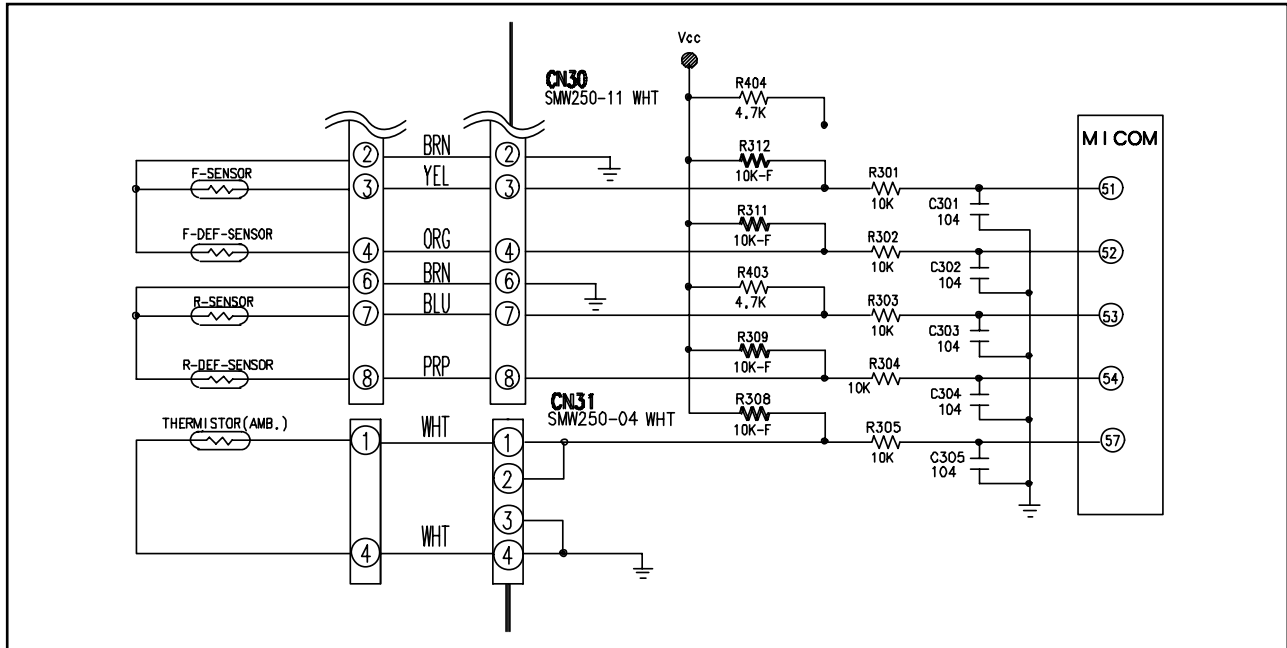

* Check after disassembling connected to MAIN PCB CN30&CN31

* Because it is NTC TYPE Sensor, resistance decreases as temp increases

1. Measure resistance between CN30 ⑦ and ⑥ for R-Sensor.
2. Measure resistance between CN30 ② and ③ for F-Sensor.
3. Measure resistance between CN30 ⑧ and ⑥ for R Defrost Sensor.
4. Measure resistance between CN30 ② and ④ for F Defrost Sensor.
5. Measure resistance between CN31 ① and ④ for Ambient Sensor.
6. Compare the above values with current temps of Sensor locations (21.Temp Sensing Circuit Table)and Part Spec in Manual and evaluate them.

14-3 Others (Measure Load Terminals)

NO	ITEM	SPEC	CODE NO	REMARK
1	PBA MAIN	05 W2 PBA MAIN	DA41-00293A	
2	PBA PANEL	05 W2 PBA PANEL,BLUE	DA41-00264A	
3	TRANS DC	115V/60Hz	DA26-00022B	
		220V/50,60Hz	DA26-00022C	
		127V/60Hz	DA26-00022D	
		230V/60Hz	DA26-00022E	
4	SENSOR	F DEFROST SENSOR	DA32-00006C	
		R DEFROST SENSOR	DA32-00006C	
		F SENSOR	DA32-10105S	
		R SENSOR	DA32-10105T	
		AMBIENT SENSOR	DA32-00011L	

- The second part (DA41-XXXXX?)of CODE for MAIN PCB ASS'Y PART may change according to MICOM or Option change,so check it when asking for parts.

15. PCB DIAGRAM

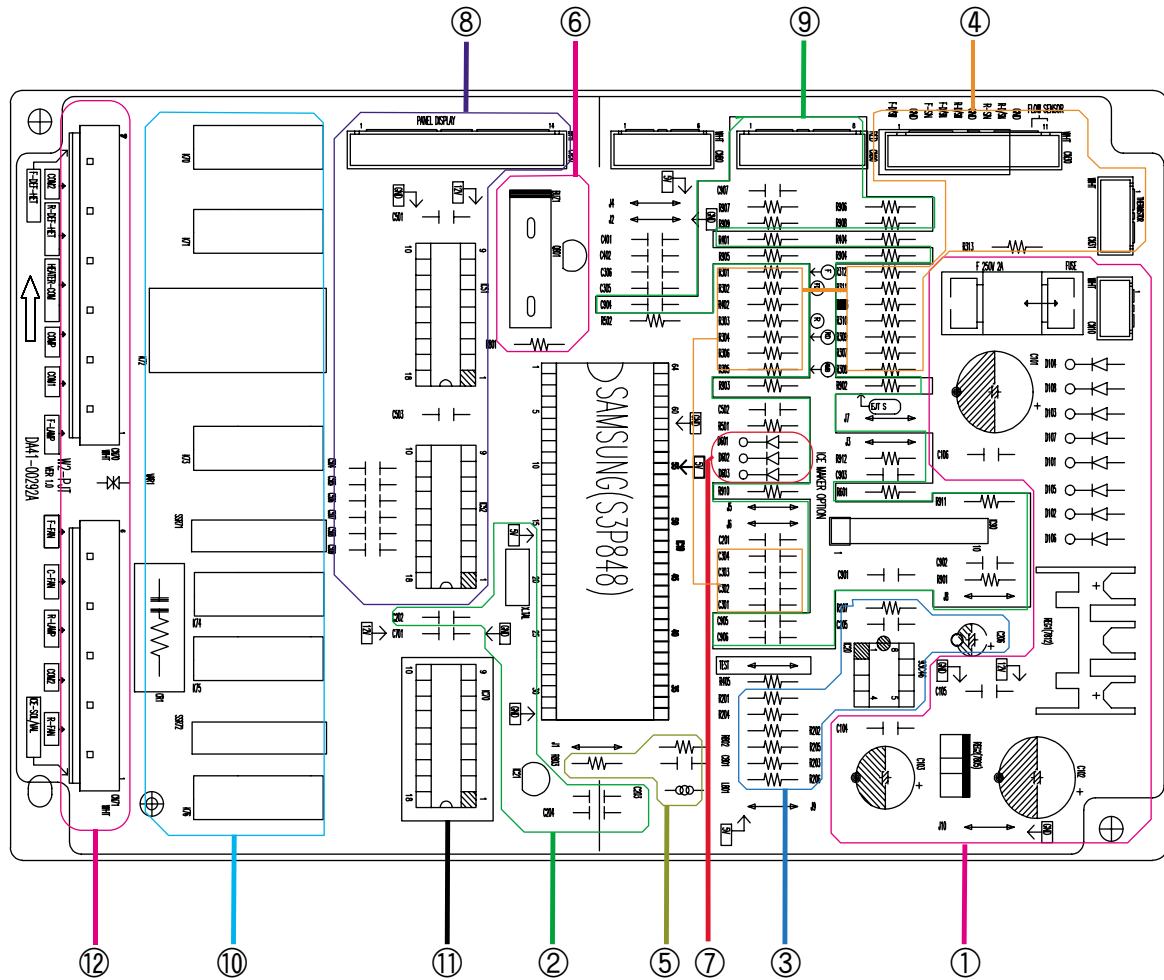

1. AC is input via Connector CN10 and DC12V,5V and GND are supplied via Regulator.
2. Oscillator generating clocks required for the MICOM program control & Reset circuit initializing programs upon power on/off.
3. EEPROM: It stores data.
4. It receives various sensor signals such as F/R Door S/W On/Off and sends them to MICOM after filtering their noises.
5. PLC (Power Line Communication) Circuit
6. Buzzer Circuit
7. Circuit for model classifying options
8. It is the display driving part controlling the LEDs and the button signals.
9. It carries out the Ice Maker operation, supplies power to the motor and detects the S/W on/off.
10. It is Relay controlling AC load and operates by receiving drive signals through IC ⑪.
11. Relay Driver IC
12. AC connector

16. CONNECTOR ARRANGEMENT & DESCRIPTIONS

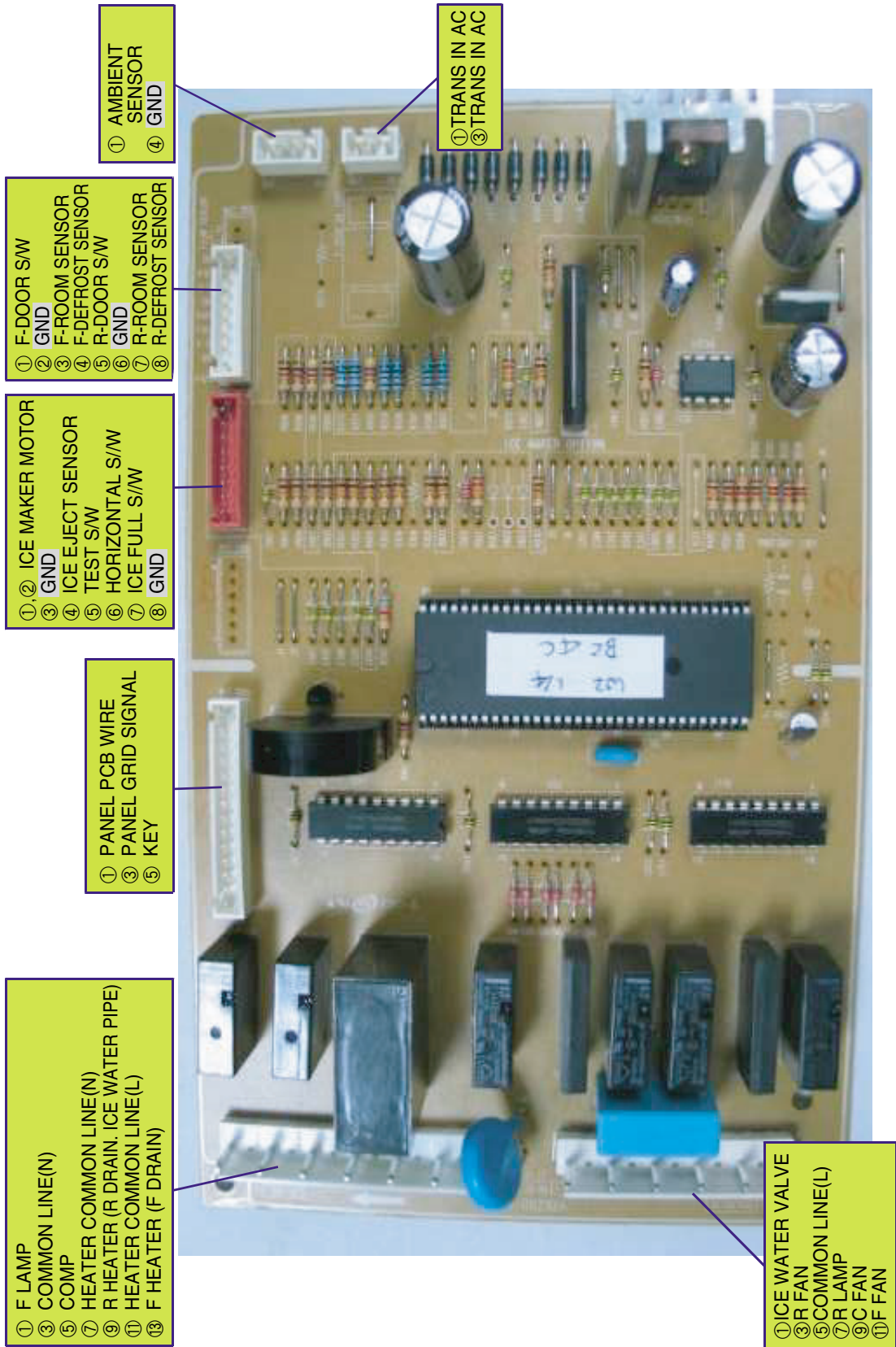

- ① F LAMP
- ③ COMMON LINE(N)
- ⑤ COMP
- ⑦ HEATER COMMON LINE(N)
- ⑨ R HEATER (R DRAIN, ICE WATER PIPE)
- ⑪ HEATER COMMON LINE(L)
- ⑬ F HEATER (F DRAIN)

- ① PANEL PCB WIRE
- ③ PANEL GRID SIGNAL
- ⑤ KEY

- ①, ② ICE MAKER MOTOR
- ③ GND
- ④ ICE EJECT SENSOR
- ⑤ TEST S/W
- ⑥ HORIZONTAL S/W
- ⑦ ICE FULL S/W
- ⑧ GND

- ① F-DOOR S/W
- ② GND
- ③ F-ROOM SENSOR
- ④ F-DEFROST SENSOR
- ⑤ R-DOOR S/W
- ⑥ GND
- ⑦ R-ROOM SENSOR
- ⑧ R-DEFROST SENSOR

- ① AMBIENT SENSOR
- ④ GND

- ① TRANS IN AC
- ③ TRANS IN AC

- ① ICE WATER VALVE
- ③ R FAN
- ⑤ COMMON LINE(L)
- ⑦ R LAMP
- ⑨ C FAN
- ⑪ F FAN

17. BLOCK DIAGRAM

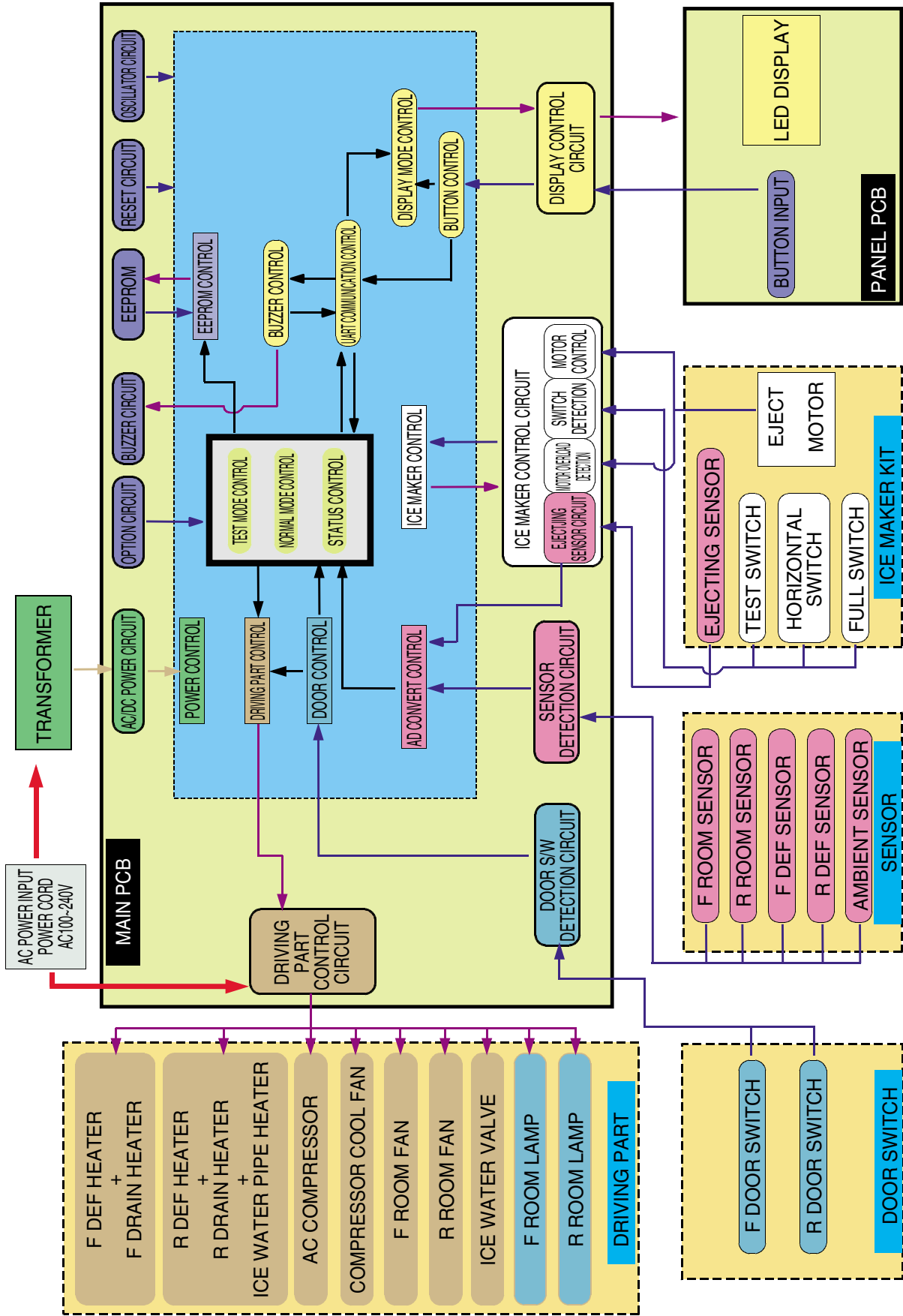

18. CIRCUIT DIAGRAM

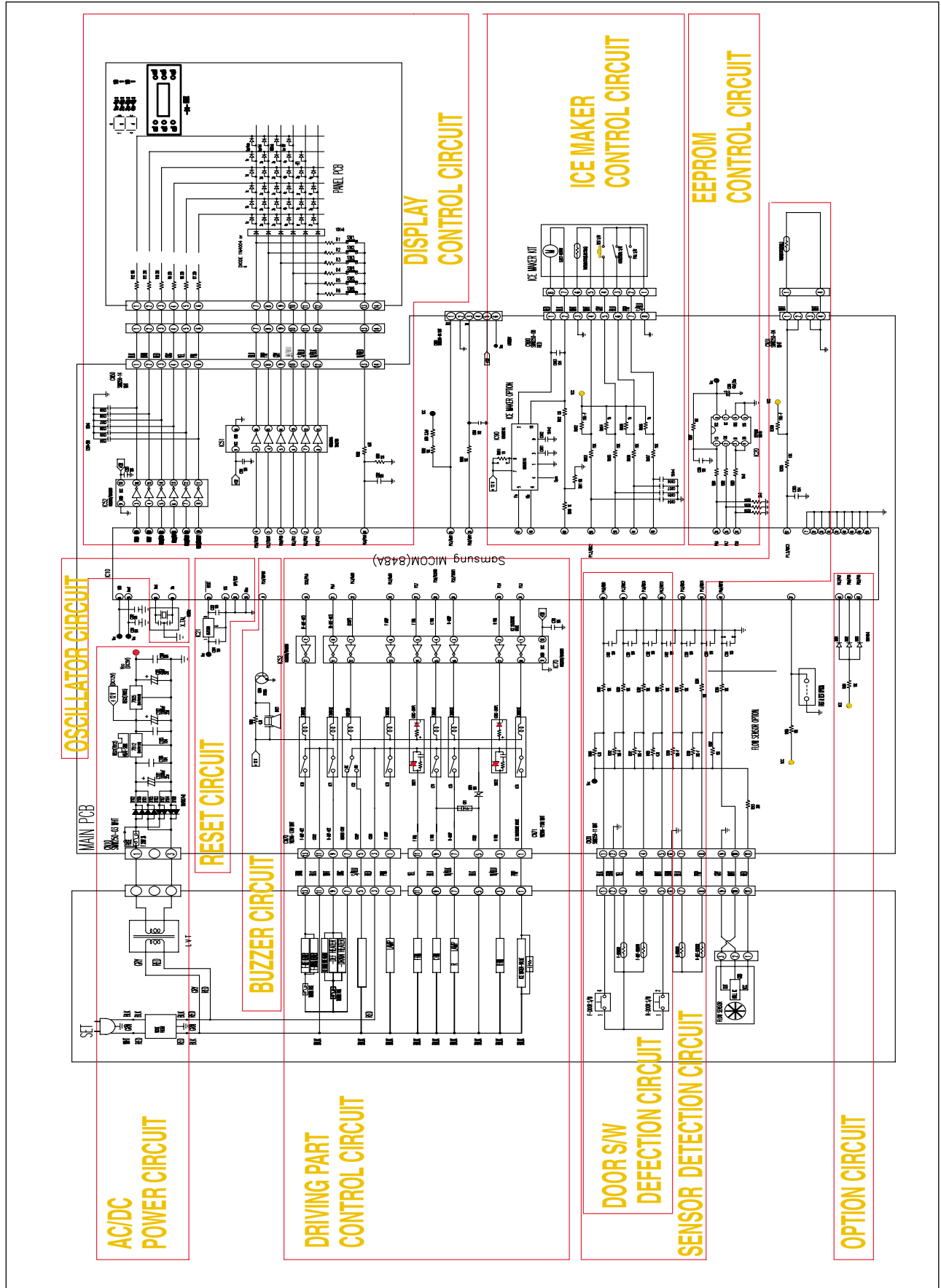

19. WIRING SCHEMATIC

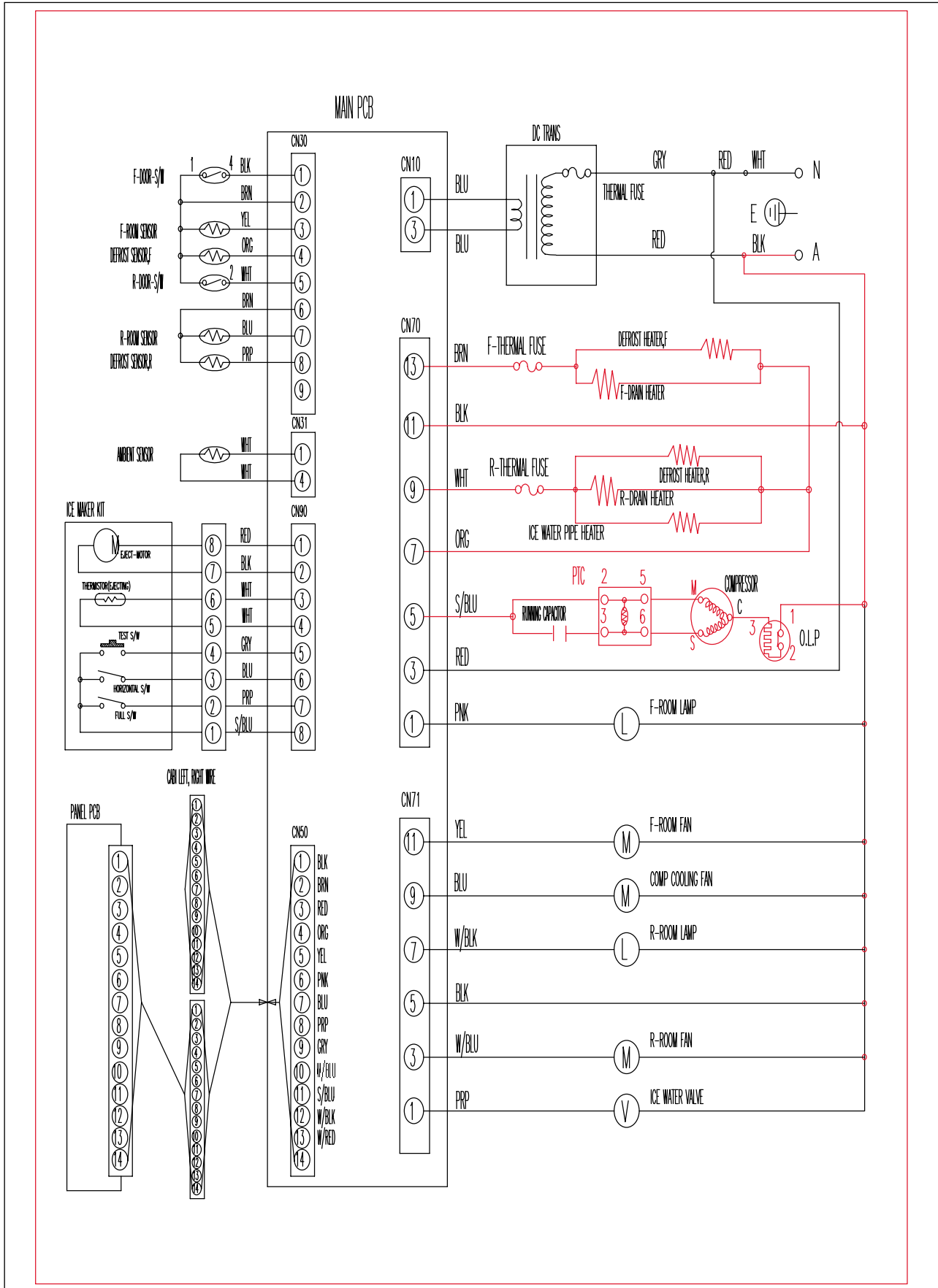

20. Temp to Resistance of Sensor & MICOM PORT Voltage

- Sensor CHIP:PX41C Standard

°C	°F	V	Ω	°C	°F	V	Ω	°C	°F	V	Ω
-50	-58	4.694	153319	-5	23	3.107	16419	40	104	1.153	2997
-49	-56.2	4.677	144794	-4	24.8	3.057	15731	41	105.8	1.124	2899
-48	-54.4	4.659	136798	-3	26.6	3.006	15076	42	107.6	1.095	2805
-47	-52.6	4.641	129294	-2	28.4	2.955	14452	43	109.4	1.068	2714
-46	-50.8	4.622	122248	-1	30.2	2.904	13857	44	111.2	1.040	2627
-45	-49	4.602	115631	0	32	2.853	13290	45	113	1.014	2543
-44	-47.2	4.581	109413	1	33.8	2.802	12749	46	114.8	0.988	2462
-43	-45.4	4.560	103569	2	35.6	2.751	12233	47	116.6	0.963	2384
-42	-43.6	4.537	98073	3	37.4	2.700	11741	48	118.4	0.938	2309
-41	-41.8	4.514	92903	4	39.2	2.649	11271	49	120.2	0.914	2237
-40	-40	4.490	88037	5	41	2.599	10823	50	122	0.891	2167
-39	-38.2	4.465	83456	6	42.8	2.548	10395	51	123.8	0.868	2100
-38	-36.4	4.439	79142	7	44.6	2.498	9986	52	125.6	0.846	2036
-37	-34.6	4.412	75077	8	46.4	2.449	9596	53	127.4	0.824	1973
-36	-32.8	4.385	71246	9	48.2	2.399	9223	54	129.2	0.803	1913
-35	-31	4.356	67634	10	50	2.350	8867	55	131	0.783	1855
-34	-29.2	4.326	64227	11	51.8	2.301	8526	56	132.8	0.762	1799
-33	-27.4	4.296	61012	12	53.6	2.253	8200	57	134.6	0.743	1745
-32	-25.6	4.264	57977	13	55.4	2.205	7888	58	136.4	0.724	1693
-31	-23.8	4.232	55112	14	57.2	2.158	7590	59	138.2	0.706	1642
-30	-22	4.199	52406	15	59	2.111	7305	60	140	0.688	1594
-29	-20.2	4.165	49848	16	60.8	2.064	7032	61	141.8	0.670	1547
-28	-18.4	4.129	47431	17	62.6	2.019	6771	62	143.6	0.653	1502
-27	-16.6	4.093	45146	18	64.4	1.974	6521	63	145.4	0.636	1458
-26	-14.8	4.056	42984	19	66.2	1.929	6281	64	147.2	0.620	1416
-25	-13	4.018	40938	20	68	1.885	6052	65	149	0.604	1375
-24	-11.2	3.980	39002	21	69.8	1.842	5832	66	150.8	0.589	1335
-23	-9.4	3.940	37169	22	71.6	1.799	5621	67	152.6	0.574	1297
-22	-7.6	3.899	35433	23	73.4	1.757	5419	68	154.4	0.560	1260
-21	-5.8	3.858	33788	24	75.2	1.716	5225	69	156.2	0.546	1225
-20	-4	3.816	32230	25	77	1.675	5039	70	158	0.532	1190
-19	-2.2	3.773	30752	26	78.8	1.636	4861	71	159.8	0.519	1157
-18	-0.4	3.729	29350	27	80.6	1.596	4690	72	161.6	0.506	1125
-17	1.4	3.685	28021	28	82.4	1.558	4526	73	163.4	0.493	1093
-16	3.2	3.640	26760	29	84.2	1.520	4369	74	165.2	0.481	1063
-15	5	3.594	25562	30	86	1.483	4218	75	167	0.469	1034
-14	6.8	3.548	24425	31	87.8	1.447	4072	76	168.8	0.457	1006
-13	8.6	3.501	23345	32	89.6	1.412	3933	77	170.6	0.446	978
-12	10.4	3.453	22320	33	91.4	1.377	3799	78	172.4	0.435	952
-11	12.2	3.405	21345	34	93.2	1.343	3670	79	174.2	0.424	926
-10	14	3.356	20418	35	95	1.309	3547	80	176	0.414	902
-9	15.8	3.307	19537	36	96.8	1.277	3428	81	177.8	0.404	877
-8	17.6	3.258	18698	37	98.6	1.253	3344	82	179.6	0.394	854
-7	19.4	3.208	17901	38	100.4	1.213	3204	83	181.4	0.384	832
-6	21.2	3.158	17142	39	102.2	1.183	3098	84	183.2	0.375	810

