

SERVICE NOTE BOOK
ALL REFRIGERATOR MODELS
VUAR--VRBD--VUBD--VUWC



VIKING RANGE CORPORATION

VIKING RANGE CORPORATION, P.O. DRAWER 956, GREENWOOD, MS. 38930-USA

TABLE OF CONTENTS

General Information -----	4
Most often Misdiagnosed Problem -----	4
Troubleshooting Guide	
1. Interior too Cool or Contents Freezing -----	6
2. Interior too Warm (Compressor Operates) -----	8
3. Excessive Frost Build-up on Evaporator. (Interior Temperatures Normal and Frost Pattern Uniform.) -----	10
4. Compressor, Fan and Interior Light do not Function -----	11
5. Interior Light Functions but Compressor will not Run -----	12
6. Compressor Runs, Fan does not Run -----	12
7. Fan Runs, but Compressor does not Run -----	12
8. Interior Light will not turn OFF when Door is Closed -----	12
Thermostat Specifications -----	13
Wiring Diagram -----	14
Appendix: Solid State Control -----	15

VIKING RANGE ALL-REFRIGERATION MODELS

VUWC140/150—VUAR140/150—VRBD—VUBD

The all-refrigerator product line encompasses traditional all-refrigerators, beverage storage all-refrigerators with temperature barriers to create different temperature zones, refrigerator beverage dispensers, and wine storage refrigerators.

All these models employ an evaporator plate for cooling the cabinet interior and an evaporator plate sensing thermostat to control the compressor operation and therefore, the interior temperature.

A cycle defrost system is also used on all these models. The plate sensing thermostat is designed such that at the end of each compressor run cycle, the evaporator plate must “warm-up” above a freezing temperature before the compressor will restart. During this “warm-up” period, any accumulated frost on the evaporator melts and drips off the evaporator plate into drip channels and a drip tray. From the drip tray, a drain tube carries the defrost water to a pan in the mechanical compartment. There, condenser fan air movement and compressor heat evaporate the water.

Most Often Misdiagnosed Problem

Sealed refrigeration system leaks are the most often misdiagnosed problem on the Viking all-refrigerator models. The interaction between the evaporator sensing thermostat, the mounting location of the thermostat thermobulb, and a low refrigerant condition within the evaporator, yields a condition in which the cabinet interior air temperature drops below freezing and stored commodities become frozen.

End users respond to the colder interior temperatures by adjusting the thermostat knob to a warmer setting, until they reach the warmest available. When their stored commodities continue to freeze at the warmest setting, they call for service. The end user states the problem as “the thermostat is set at its warmest setting yet everything inside freezes.”

This leads most service technicians to suspect a bad thermostat. When the technician examines the unit and finds that the compressor runs continuously, the tentative diagnosis is confirmed. The technician’s diagnosis is that the thermostat is not functioning properly and he replaces it. When this does not correct the problem, often the thermostat is replaced a second time because the technician believes the first replacement thermostat might have also been defective. By this time, the end user is upset because the technician cannot repair his unit and the technician is contacting the Viking Customer Services Department to inform us that he has received two “defective” thermostat service assemblies!

What a mess! Let’s back-up to the beginning to determine where this service call went wrong. When the end user stated the problem as “the thermostat is set at its warmest setting yet everything inside freezes”, the technician automatically thought, “too much run time”, probably bad thermostat. But the problem was actually a low refrigerant charge or leak. Typically, when

Customers complain about a refrigerator operating too cold, we don't usually think about a low refrigerant charge or leak. A low charge or leak typically causes the opposite problem – the interior becomes too warm as the system runs out of cooling capacity.

The rest of the problem is the “unique” way, some call it the “backwards” way, that the Viking all refrigerator models react to a low refrigerant volume condition.

When there is a low refrigerant condition in the unit, the gas volume is insufficient to fill all the tracks in the plate evaporator. As a result, areas not filled with gas do not achieve the very cold plate sensing thermostats cut-out temperatures. Therefore, whenever the remaining refrigerant gas volume is not sufficient to fill the area of the evaporator where the thermostat's sensing thermobulb is mounted, the compressor runs continuously. Usually the cooling capacity of the remaining portion of the evaporator which still contains refrigerant, is sufficient to achieve air temperatures below freezing in the unit when the compressor runs continuously.

Therefore, when dealing with plate sensing thermostats, as opposed to air temperature sensing thermostats, we must adjust our thinking about how the sealed refrigeration system can react to a low or leak condition. The conditions described above are representative of a slow leak where the system still retains a partial charge.

The recommended diagnostic approach for complaints of “operation too cold on lowest setting” is to insure the compressor is operating and then open the unit door. Allow the door to remain open for about 5 minutes and observe the frost pattern that forms on the evaporator.

On a properly charged unit, the frost pattern should be continuous and uniform over the entire surface of the evaporator. The frost pattern should extend from the left-hand wing of the evaporator across the back segment and around to the right-hand wing. If this frost pattern is present, the thermostat or its thermo-bulb mount are possible the source of the too cold condition.

On a unit with a low charge or leak condition, the frost pattern, if present, will typically cover the left wing and perhaps a part of the back. It will not be present on the entire back or right wing of the evaporator plate as viewed.

The thermo-bulb mounting location on the VRBD—VUBD—VUAR is at the top of the evaporator plate on the portion across the rear of the cabinet. On the model VUWC, the thermo-bulb is mounted to the right wing of the evaporator plate as viewed.

When an incomplete frost pattern is present which does not cover the area where the thermo-bulb is mounted, the problem is a leak or low refrigerant charge. Changing the thermostat will not correct the “too cold” condition. Locating the leak, sealing it and evacuation and recharging the system is the only permanent solution. Leak check all braze joints on the refrigerant tubes and check all sealed system components for the source of the leak. Include the tubes themselves, the process stub close-out welds and the copper-to-aluminum braze way joints at the evaporator inlet and outlet. The braze way welds are difficult to leak check in the cabinet. If the rest of the system has been thoroughly checked and no leaks have been found, the braze ways are the likely

source of a leak. The braze ways cannot be brazed/repared. The evaporator assembly must be replaced to repair a leak in this area.

Occasionally, corrosion develops under the thermo-bulb mounting clamp causing a leak, so leak check this area thoroughly. Also, if this is the leak source, replace the evaporator assembly.

Hopefully, this information will help you properly diagnose sealed refrigeration system leak conditions which you encounter on Viking all-refrigerator models in the field. When these problems are properly diagnosed and promptly repaired, the customer, the service technician and Viking all benefit.

**TROUBLESHOOTING FOR VIKING ALL-REFRIGERATOR
AND WINE STORAGE ALL-REFRIGERATOR MODELS**

PROBLEM	CHECK	POSSIBLE CAUSE	REMEDY
1. Interior too cold or contents freezing.	a. Thermostat setting	1. Thermostat set to too cold of a setting for ambient conditions.	1. Adjust thermostat to warmer setting (lower number on knob)
	b. The evaporator for the presence of a uniform frost pattern Is the frost confined to left wing and left side of the back? Note compressor should be operating for at least 5 minutes with door open to perform this check. See previous page for explanation unique problem.	1. Refrigerant leak or low refrigerant charge in the sealed system. Refrigerant volume is evaporator is not sufficient to cool the region of the plate where the evaporator plate sensing thermostat's thermo-bulb mounts. Therefore the control thermostat never reaches its cut-out temperature and the compressor Operates 100% of the time. The remaining evaporator volume is sufficient to cool the air temperature below freezing.	1. locate and correct cause of refrigerant leak. Replace drier, evaporator, and Recharge sealed refrigerant system with the proper amount of charge as listed on the unit's data plate.

PROBLEM	CHECK	POSSIBLE CAUSE	REMEDY
	c. Thermostat (compressor control) thermo-bulb mounting or routing.	1. Mounting location incorrect. Model VUCW should be on the right wing of the evaporator plate. All other models mount at rear top center of the evaporator.	1. Relocate thermo-bulb to proper location
		2. Thermostat sensing tube (capillary tube) resting on or above compressor dome in mechanical compartment causing false sensing.	2. Reroute sensing tube clear of compressor dome area.
		3. Thermostat thermo-bulb mounting bracket not secure, causing false sensing.	3. Securely tighten thermo-bulb mounting bracket.
		4. Insufficient thermo-bulb contact area. on evaporator U-shaped loop with 3-inch long legs required bracket Bracket should be located at midpoint of each 3-inch leg. Both legs secured under bracket	4. Adjust thermo-bulb contact area to achieve sufficient contact. A U-shaped loop with 3-inch long legs is required. The mounting bracket should be located at the mid point of each 3-inch leg. Both legs secured under bracket.
	d. Compressor control thermostat cut-out temperature.	1. Cut-out temperature too low due to internal failure in the thermostat	1. Replace the thermostat

PROBLEM	CHECK	POSSIBLE CAUSE	REMEDY
	e. Placement of glass shelves in cabinet	1. If white rubber “shelf bumper” do not space the glass shelf out away from the molded inner-liner shelf supports on the back of the cabinet interior. The cold air from the evaporator can be “trapped” above the the shelf resulting in the area above the shelf becoming too cold and below too warm. (This applies to models with glass shelves only.)	1. Properly place the glass shelves in the unit. White rubber “shelf bumper” must be placed so as to create an air space gap between the rear edge of the glass shelf and the molded shelf supports on the cabinet interior.
2. Interior too warm	a. Thermostat	1. Thermostat set to too low (warm) of a setting.	1. Adjust thermostat, to a colder setting (higher number on knob).
		2. Thermostat failed, cutting compressor off too soon.	2. Replace thermostat. Leak check the sealed Refrigeration system. Locate and correct the source of the leak. Replace the drier and recharge to proper amount. 2a. Replace the thermostat with the solid state AC control..(See appendix page15).
	b. the evaporator for the presence of a frost pattern not present with compressor operating.	1. Refrigerant leak.	1. Leak check the sealed refrigeration system. locate and correct the source of the leak. Replace the drier and recharge to proper amount.

PROBLEM	CHECK	POSSIBLE CAUSE	REMEDY
	c. High and low side pressure in the sealed system.	1. Compressor valve failure, preventing compressor from developing required refrigerant pressures for system operation.	1. Replace compressor and drier, evacuate and recharge with refrigerant to the proper amount.
		2. Restriction in the sealed refrigerant system causing high compressor discharge pressures and low pressure or vacuum Conditions on the suction side. Pressure does not equalize quickly when the compressor is turned off.	2. Locate the restriction and correct the cause. Evacuate, replace drier and recharge the sealed refrigeration system to the proper level.
	d. Interior light-- does it remain on with door closed, adding heat to the	1. Striker plate on bottom of door not present or not positioned properly to depress light switch in grille area when door is closed.	1. Replace or install striker plate on door so light switch is depressed when door is closed.
		2. Failed light activation switch not turning off light when switch is depressed.	2. Replace light activation switch.
		3. Wiring connection to or from light activation switch improperly wired bypassing switch.	3. Correct improper wiring connection.
		4. Door light activation switch over-ride switch in the "on" position permitting light to remain "on" with door closed. (Present on some but not all models.)	4. Place over-ride switch in the "door" position. Verify light goes out when door is closed by depressing Light activation switch and confirming light goes out.

PROBLEM	CHECK	POSSIBLE CAUSE	REMEDY
	e. Condenser fan operation.	1. Condenser fan blade jammed against shroud or otherwise bound.	1. Free condenser fan blade so it rotates freely.
		2. Wiring connection to and from fan motor, terminal block and thermostat loose or incorrect.	2. Correct loose or incorrect wiring connections.
		3. Condenser fan motor failed.	3. Replace condenser fan Assembly.
	f. Condenser air flow blocked or restricted.	1. Condenser air flow blocked by dirt, lint, trash , etc.	1. Clean condenser to restore air flow.
		2. Air flow in or out of toe space grille restricted.	2. Clear restriction to air flow Through toe space grille. No obstruction to air flow permitted in an area 3 feet out from the grille.
	3.Excessive frost built-Up on Evaporator (interior temperatures are normal and frost pattern is uniform).	a. Cabinet for proper sealing (absence of air leaks).	1, Exterior door of unit not hanging straight, preventing proper gasket sealing.
2. Door hinges bent.			2. Install new hinge kit to correct hang of door. Door shims may also be required. See hinge and Shim installation instructions.
3. Air leaks at locations where refrigerant line, electrical wiring or thermostat capillary tubes enter cabinet interior.			3. Seal around these entry points with refrigeration putty (permagum) to eliminate air leaks.

PROBLEM	CHECK	POSSIBLE CAUSE	REMEDY
		4. Air leaks around door gasket due to physical contour of gasket.	4. Reform gasket using heat to achieve a complete seal.
		5 Door gasket torn or has lost magnetism.	5. Replace gasket if stiff or has weak magnetism.
		6. Damage to cabinet front flange (gasket sealing area).	6 Straighten area to permit proper seal. If unable to achieve proper seal, unit is non-repairable.
	b. Extended or too frequent door openings.	1. Extended or too frequent door openings allow warm, moist air to reach cold evaporator plate causing heavier frost built-up.	1. Reduce frequency and duration of door openings.
4. Compressor and interior lights don't function.	a. Power supply.	1. Unit not plugged into power outlet.	1. Plug unit into power outlet.
		2. Fuses or circuit breaker tripped.	2. Replace fuse. Reset circuit breaker. Correct power supply problem.
	b. Power cord and wiring connections within unit from power cord to thermostat and terminal block.	1. Loose or incorrect wiring connections at power cord, thermostat input or terminal block.	1. correct loose or incorrect wiring connections.

PROBLEM	CHECK	POSSIBLE CAUSE	REMEDY
5. Interior light functions but compressor will not run.	a. Compressor control thermostat.	1. Compressor control thermostat.	1. Replace compressor control thermostat.
		2. Wiring connections from compressor control Thermostat to terminal Block loose or incorrect.	2. Correct loose or incorrect wiring connections.
6. Compressor runs: fan does not run.	a. Fan motor blade assembly.	1. Fan blade jammed by shroud, refrigerant line, mount bracket, foreign objects, etc.	1. Free fan blade so fan operates freely.
		2. Fan motor failed.	2. Replace fan motor.
		3. Connection loose or incorrect on wiring from fan motor to terminal block.	3. Correct loose or incorrect wiring connections.
7. Fan runs, but	a. PTC starter.	1. Failed PTC starter.	1. Replace PTC starter.
	b. Wiring PTC start to terminal block.	1. loose or incorrect wiring connections at PTC starter to terminal block.	1. Correct loose or incorrect wiring.
	c. Compressor	1. Failed motor in compressor.	1. Replace compressor
2. Compressor cycled off on thermal overload protector.		2. Unplug unit. Allow compressor to cool 30-45 minutes. Plug unit in. If compressor starts, locate cause of thermal overload. may be power interruption, high ambient temperature, or fan/condenser blocked.	
8. Interior light will not turn	a. Striker plate on bottom of door.	1. Striker plate not present or not positioned properly to depress light switch when door is closed.	1. Replace or install striker plate so light switch is depressed when door is closed.

PROBLEM	CHECK	POSSIBLE CAUSE	REMEDY
	b. Light activation switch.	1. Failed light activation switch.	1. Replace light activation switch.
	c. Wiring connection to and from light activation switch and over-ride switch.	1. Improperly wired bypass switch or over-ride switch.	1. Correct improper wiring connections
	d. Position of door light activation over-ride switch is in the “on” position.	1. If over-ride switch is in the “on” position instead of the “door” position, the light will remain on with the door closed. This is intended for glass door viewing with door closed.	1. Place over-ride switch in the “door” position. Verify light goes out when door is closed by depressing light activation switch and confirming light goes out.
	e. Over-ride switch operation.	1. Failed over-ride switch.	1. Replace over-ride switch.

THERMOSTAT SPECIFICATIONS VUAR—VRBD—VUBD			
	Thermostat Knob Setting	(°F) Cut-In	(°F) Cut-Out
Warmest Setting	No. 1	38° ± 2.7°	7.5° ± 2.7°
Mid Setting	No. 3 ½	38° ± 1.5°	1° ± 2°
Coldest Setting	No. 7	38° ± 2.7°	.6° ± 2.7°

- Light bulb is intermediate 15 watt bulb. DO NOT use a higher wattage bulb.
- Optional item.

WIRING DIAGRAM VUAR—VUWC

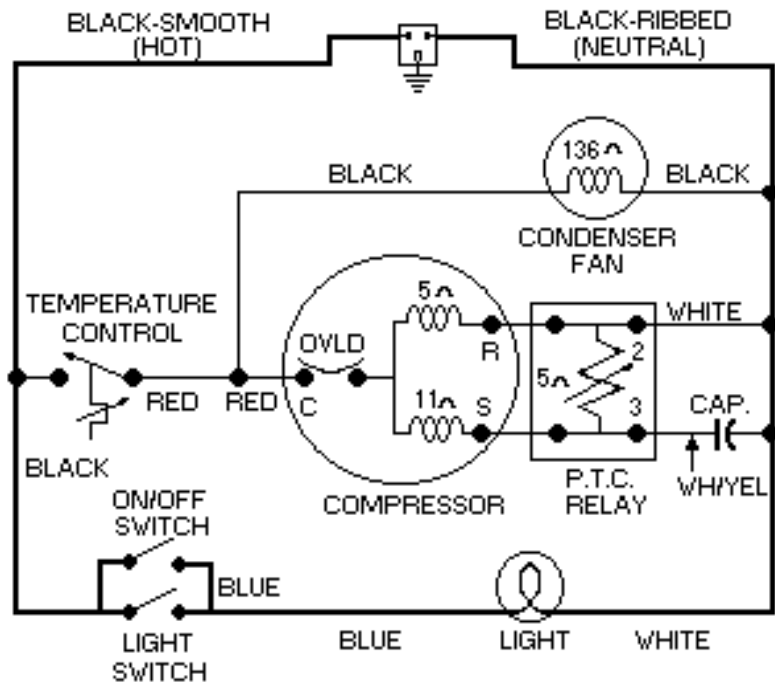

WIRING DIAGRAM VUBD—VRBD

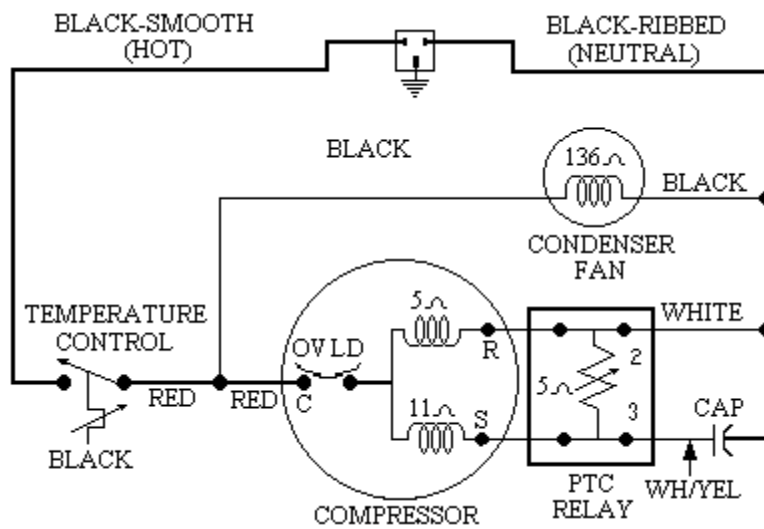

APPENDIX:

INSTRUCTIONS FOR FIELD INSTALLATION SOLID STATE AC CONTROLS ON VUAR140 / VRBD / VUBD / VUAR150 / VUWC150 ONLY

TOOLS NEEDED: 5/16" NUT DRIVER AND PHILLIPS SCREW DRIVER

1. Before working on the unit unplug it first.
2. Using the Phillips screwdriver, remove the screws from the grille on the front of the unit.
3. Carefully pull the wires off of the old thermostat.
4. Unscrew the thermostat from the bracket.
5. Loosen the screw holding the thermobulb clamp on.
6. Gently remove the thermobulb away from clamp.
7. Go to rear of unit and gently pull the capillary tube from the thermostat out of the unit.
8. Set dip switches for the correct unit. (Ill # 1)

9. Mount control on base plate in location shown in the supplied drawing.
10. Plug in molded connector from the power cord to control (match up according to the color of the wires).
11. Install neutral wire to control.

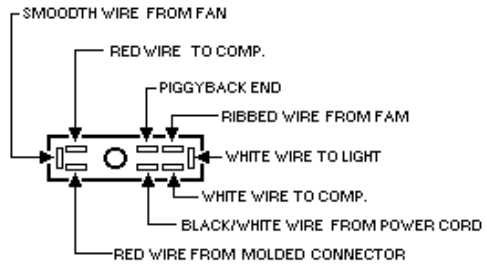

12. Install Potentiometer according to supplied drawing.
13. Route wire back and plug into control.
14. Feed thermistor from the back and install on evaporator plate
15. Route remaining thermistor wire along insulated tube and cable tie securely.
16. Plug thermistor into control.
17. Put unit back together.

SWITCH SETTING	UNIT APPLICATION	SWITCH SETTING	UNIT APPLICATION	
	VUAR140 VRBD VUBD		VUWC140	THE REMAINING SWITCH COMBINATIONS ARE NOT USED. SETTING THE SWITCHES TO AN UNLISTED COMBINATION WILL CAUSE THE UNIT TO NOT WORK.
	VUAR150		VUWC150	

Ill. # 1

9. Mount control on base plate in location

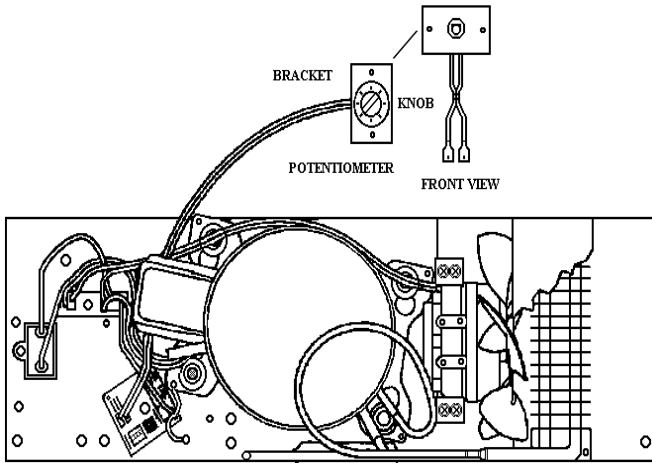

TERMINAL BLOCK

