

SERVICE MANUAL

for

THERMADOR® CHAR GLO® OUTDOOR BARBECUES

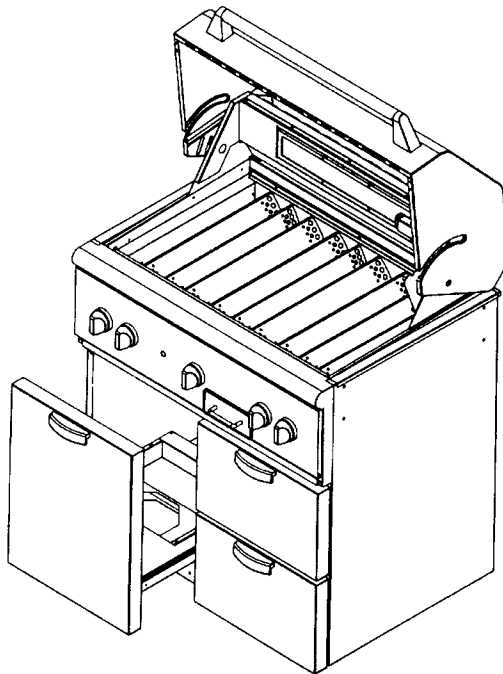

**Models:
CGB30RCULP / CGB36RU /
CGB48RU / CGB48RSBU**

Thermador®
CORPORATION

THIS MANUAL CONTAINS INFORMATION THAT IS NECESSARY FOR SERVICING THE THERMADOR® CHAR GLO® OUTDOOR BARBECUES, MODELS:
CGB30RCULP, CGB36RU, CGB48RU, & CGB48RSBU

THIS MANUAL IS DESIGNED TO BE USED ONLY BY QUALIFIED SERVICE PERSONNEL. THERMADOR RECOMMENDS THAT CUSTOMERS DO NOT SER-VICE THEIR OWN UNITS, DUE TO THE COMPLEX-ITY AND THE RISK OF HIGH-VOLTAGE ELECTRICAL SHOCK.

THE INFORMATION IS ORGANIZED TO HELP THE SERVICER EASILY FIND WHAT IS NEEDED TO REPAIR THE UNIT.

Table Of Contents

	Page
General	1-1
Serial Number/Data Sticker Location	1-1
Outdoor Barbecue Models	1-2
Symbols You Will See In The Manual	1-3
Thermador Warranty	1-4
Servicing The Components	2-1
Component Locations	2-1
Removing A Main Burner & Spark Ignitor	2-2
Removing The Smoker Burner & Spark Ignitor	2-4
Removing The Infrared Burner & Hot Surface Ignitor	2-6
Removing The Front Panel & Bullnose	2-7
Removing A Burner Control Valve, Safety Valve, Pressure Regulator, & Switch	2-8
Removing The Ignitor Switch	2-10
Removing The Spark Module & Terminal Block	2-11
Removing A Drawer Front Assembly, Handle, Thermometer, Hood, Caster, & Kick Panel	2-12
Removing A Burner Base, Jet Holder, Ignitor Plug, Spark Module, Terminal Block, & Resistor (48" Models Only)	2-14
Removing A Burner Orifice	2-16
Troubleshooting	3-1
Testing The Components	3-1
Operational Tests	3-3
Wiring Diagrams	4-1

— NOTES —

GENERAL

SERIAL NUMBER/DATA STICKER LOCATION

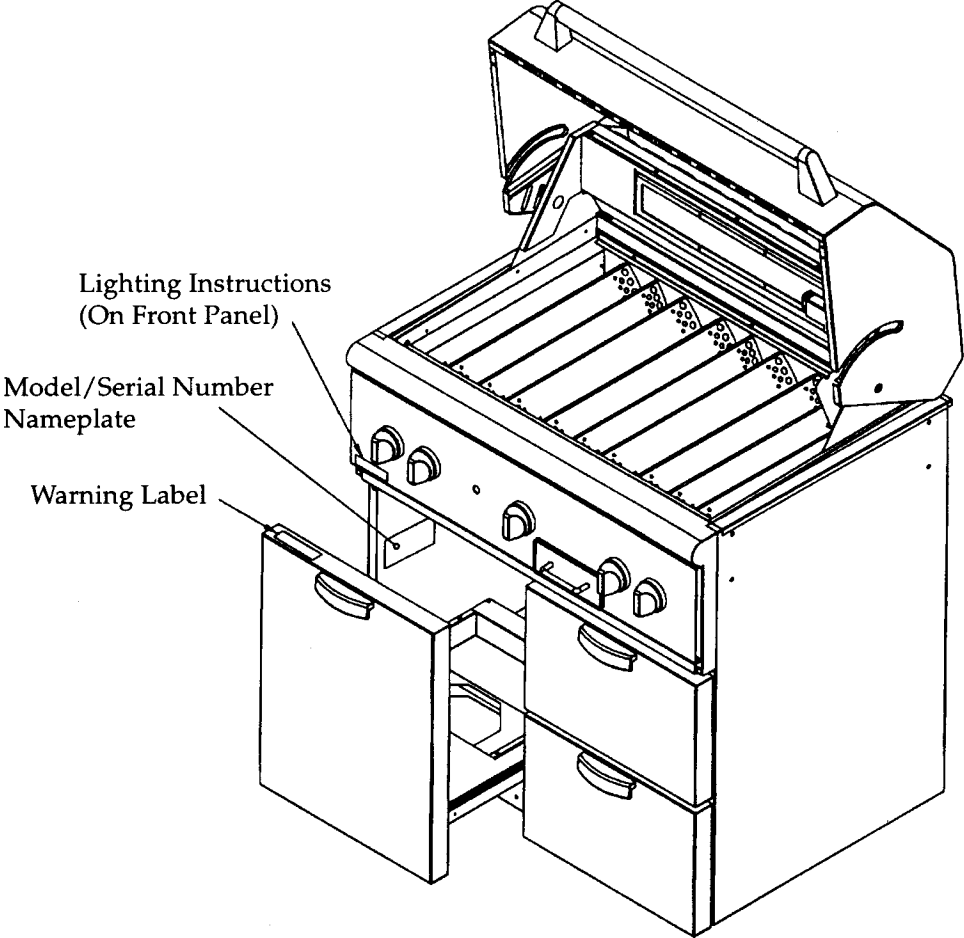

NOTE: Model CGB36RU is shown above. All other models have the Serial Number/Data Sticker in the same location.

OUTDOOR BARBECUE MODELS

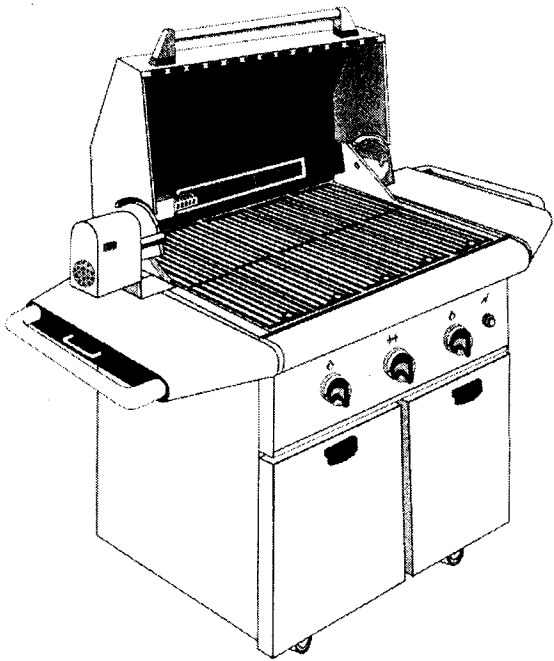

CGB30RCULP

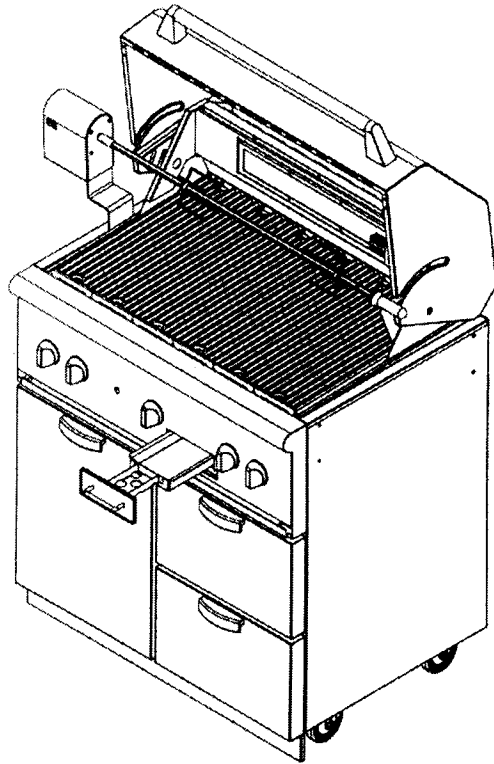

CGB36RU

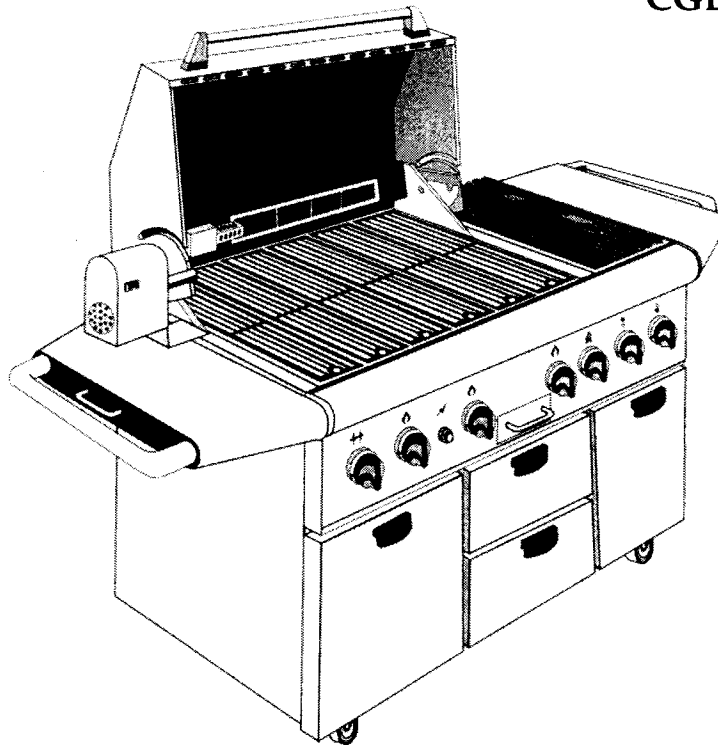

CGB48RSBU

SYMBOLS YOU WILL SEE IN THE MANUAL

The following symbols are provided throughout this manual. For reasons of personal safety and

proper operation and servicing of the barbecue, follow the instructions carefully each time you see one of the symbols.

WARNING

This symbol alerts you to such dangers as personal injury, burns, fire, and electrical shock.

CAUTION

This symbol alerts you to actions that could cause product damage (scratches, dents, etc.), and damage to your personal property.

IMPORTANT SAFETY INFORMATION

WARNING

Be sure to turn off all electrical and gas supplies to the barbecue before servicing; otherwise, a fire may result causing property damage, personal injury, or death.

Do not store or use gasoline or other flammable vapors and liquids in the vicinity of this or any other appliance.

Installation and service must be performed by a qualified installer, service agency, or the gas supplier.

This unit is for outdoor use only in a well-ventilated area. It is not to be used in a building, garage, or any other enclosed area.

WHAT TO DO IF YOU SMELL GAS

- Turn off the gas to the barbecue.
- Extinguish any open flame.
- Open the cover.
- If gas odors continue, immediately turn off the propane tank, or phone your gas supplier.
- If you cannot reach the gas supplier, call the fire department.

THERMADOR ASSUMES NO RESPONSIBILITY FOR ANY REPAIRS MADE ON OUR PRODUCTS BY ANYONE OTHER THAN AUTHORIZED THERMADOR SERVICE TECHNICIANS.

THERMADOR® WARRANTY

Length of Warranty	Thermador will pay for:	Thermador will not pay for:
<p>FULL ONE YEAR</p> <p>For one year from date of installation or date of occupancy for a new previously unoccupied dwelling. Save all dated receipts or other evidence of date of installation/occupancy date.</p>	<p>All repair labor and replacement parts found to be defective due to materials and workmanship. Service must be provided by a Factory Authorized Service Agency, during normal working hours. For a Service Agency nearest you, please call: 1-800/735-4328.</p>	<ol style="list-style-type: none"> 1. Service by an unauthorized agency. Damage or repairs by an unauthorized agency or use of unauthorized parts. 2. Service visits to: <ul style="list-style-type: none"> • Teach you how to use the appliance. • Correct the installation. You are responsible for providing electrical wiring and/or gas installation and other connecting facilities. • Reset circuit breakers or replace home fuses. 3. Damage caused from accident, abuse, alteration, misuse, incorrect installation or installation not in accordance with local codes, or improper storage of the appliance. 4. Repairs due to other than normal home use. 5. Any service visits and labor costs during the limited warranty. 6. Travel fees and associated charges incurred when the product is installed in a location with limited or restricted access, (i.e., airplane flights, ferry charges, isolated geographic regions).

This warranty applies to appliances used in normal family households; it does not cover their use in commercial situations. This warranty is for products purchased and retained in the 50 states of the U.S.A., the District of Columbia, and Canada. The warranty applies even if you should move during the warranty period. Should the appliance be sold by the original purchaser during the warranty period, the new owner continues to be protected until the expiration of the original purchaser's warranty period.

THERMADOR DOES NOT ASSUME ANY RESPONSIBILITY FOR INCIDENTAL OR CONSEQUENTIAL DAMAGES. Some states do not allow the exclusions or limitation of incidental or consequential damages, so the above limitation or exclusion may not apply to you. This warranty gives you specific legal rights. You may also have other rights which vary from state-to-state or province-to-province.

SERVICING THE COMPONENTS

COMPONENT LOCATIONS

Model CGB36RU

The serviceable components inside the Barbecue are included in this section of the manual. The procedures shown are for the Model CGB36RU, but can also be used when servicing

any of the other models. Refer to the section that deals with the component you wish to service. The component locations are shown in the illustration.

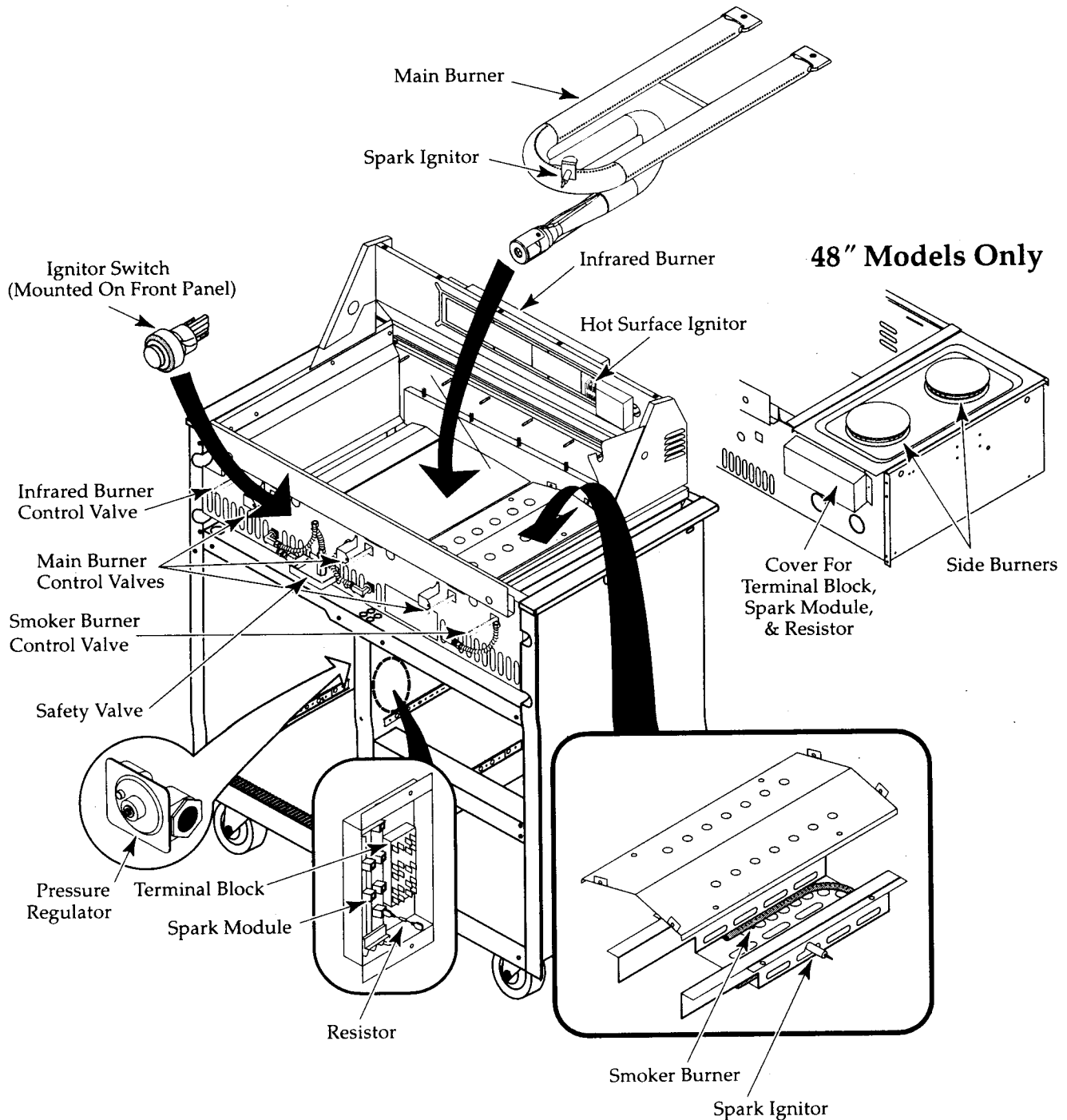

REMOVING A MAIN BURNER & SPARK IGNITOR

WARNING

Turn off the gas supply and disconnect the power cord from the AC outlet before servicing this unit.

CAUTION

When you work on the barbecue, be careful when handling the sheet metal parts. There are sharp edges present and you can cut yourself if you are not careful.

1. Turn off the gas supply and disconnect the electrical power going to the barbecue.
2. Lift the hood.
3. Remove the grates and radiant heat baffle from over the burner/spark ignitor that you wish to service.

Refer to Figure 1 for the following steps.

4. **To remove the spark ignitor (see the inset),**
 - a) Rotate the ignitor shield back just far enough to access the ignitor wire.
 - b) Disconnect the ignitor wire from the ignitor terminal.
 - c) Unclip the e-ring from the spark ignitor body and remove the ignitor from the bracket.
5. **To remove a main burner:**
 - a) Rotate the ignitor shield back just far enough to access the ignitor wire.
 - b) Disconnect the ignitor wire from the ignitor terminal.
 - c) Remove the two hex nuts w/lock-washers from the studs.
 - d) Lift the back of the burner off the studs and remove the burner.

REASSEMBLY NOTE: Be sure to rotate the ignitor shield back into position after the burner and spark ignitor are back in place.

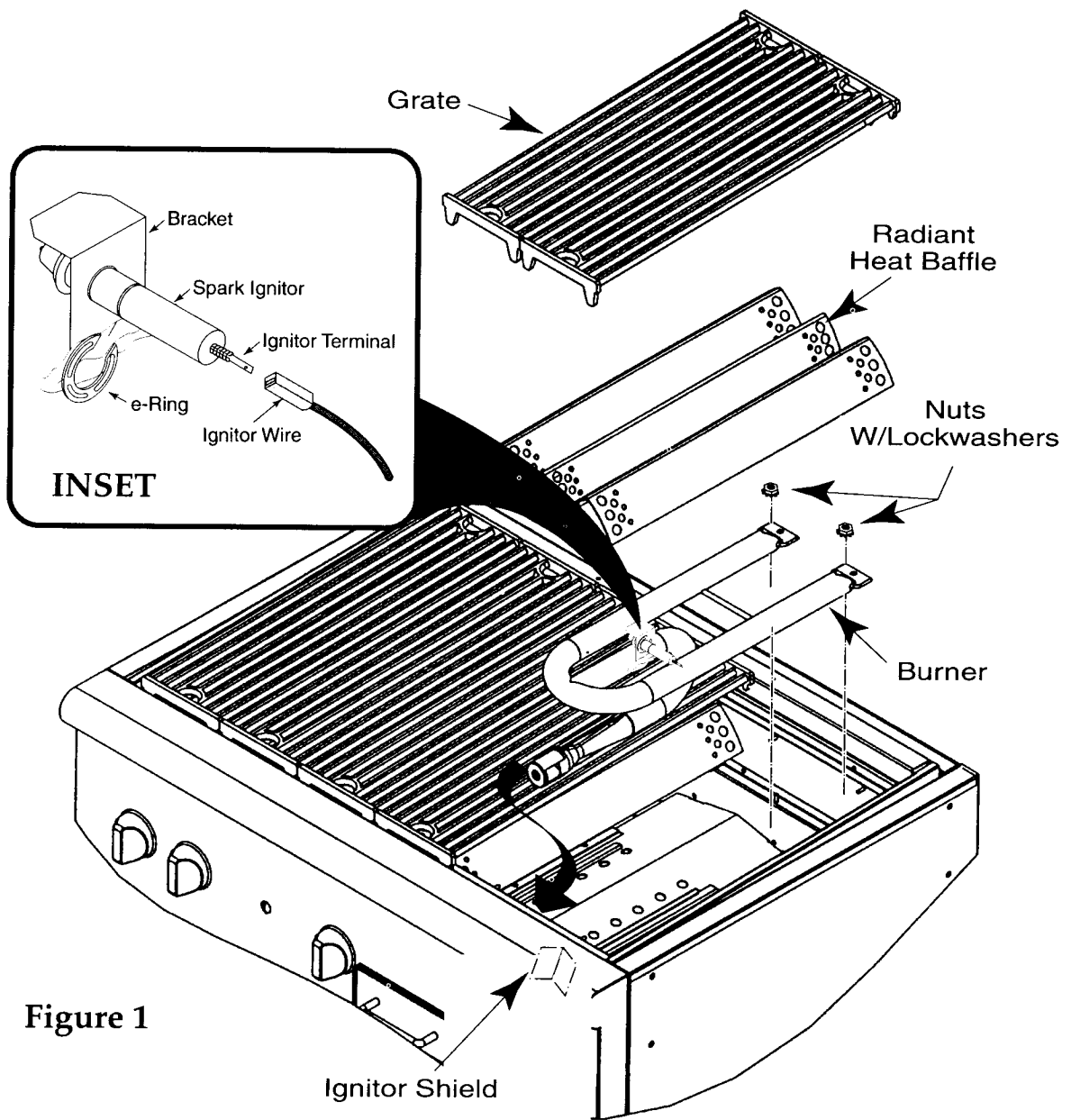

REMOVING THE SMOKER BURNER & SPARK IGNITOR

WARNING

Turn off the gas supply and disconnect the power cord from the AC outlet before servicing this unit.

CAUTION

When you work on the barbecue, be careful when handling the sheet metal parts. There are sharp edges present and you can cut yourself if you are not careful.

1. Turn off the gas supply and disconnect the electrical power going to the barbecue.
 2. Lift the hood.
 3. Remove the smoker tray from the barbecue.
 4. Remove the grate and radiant heat baffle from over the smoker burner.
- Refer to Figure 2 for the following steps.
5. Remove the six screws from the smoker burner baffle and remove the baffle.
 6. **To remove the smoker burner:**
 - a) Remove the gas line fitting from the end of the burner.
 - b) Lift the bracket and remove the mounting nuts with lockwashers from the burner studs, then lift the burner off the bracket.
 7. **To remove the spark ignitor:**
 - a) Unplug the ignitor wire from the spark ignitor terminal.
 - b) Unclip the e-ring from the spark ignitor body and remove the ignitor from the bracket.

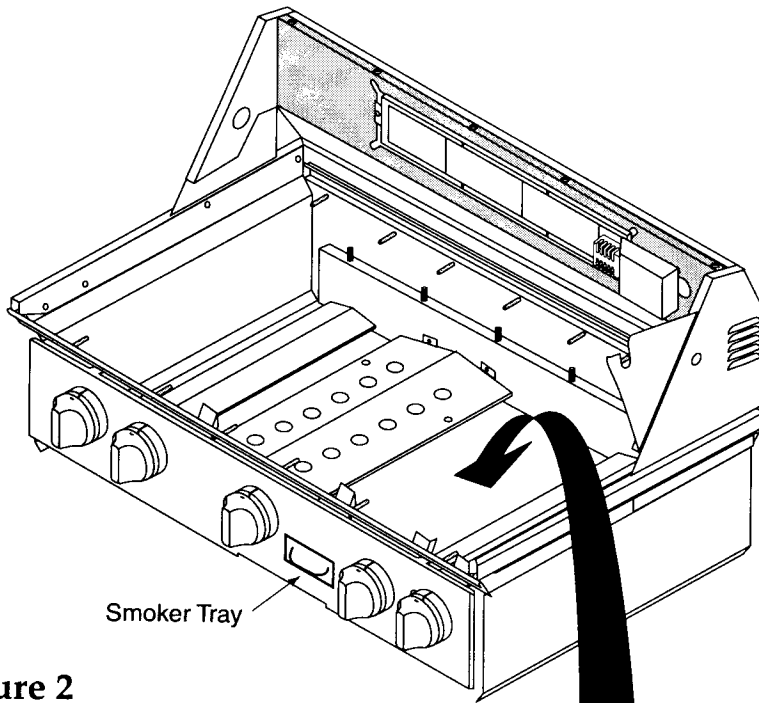
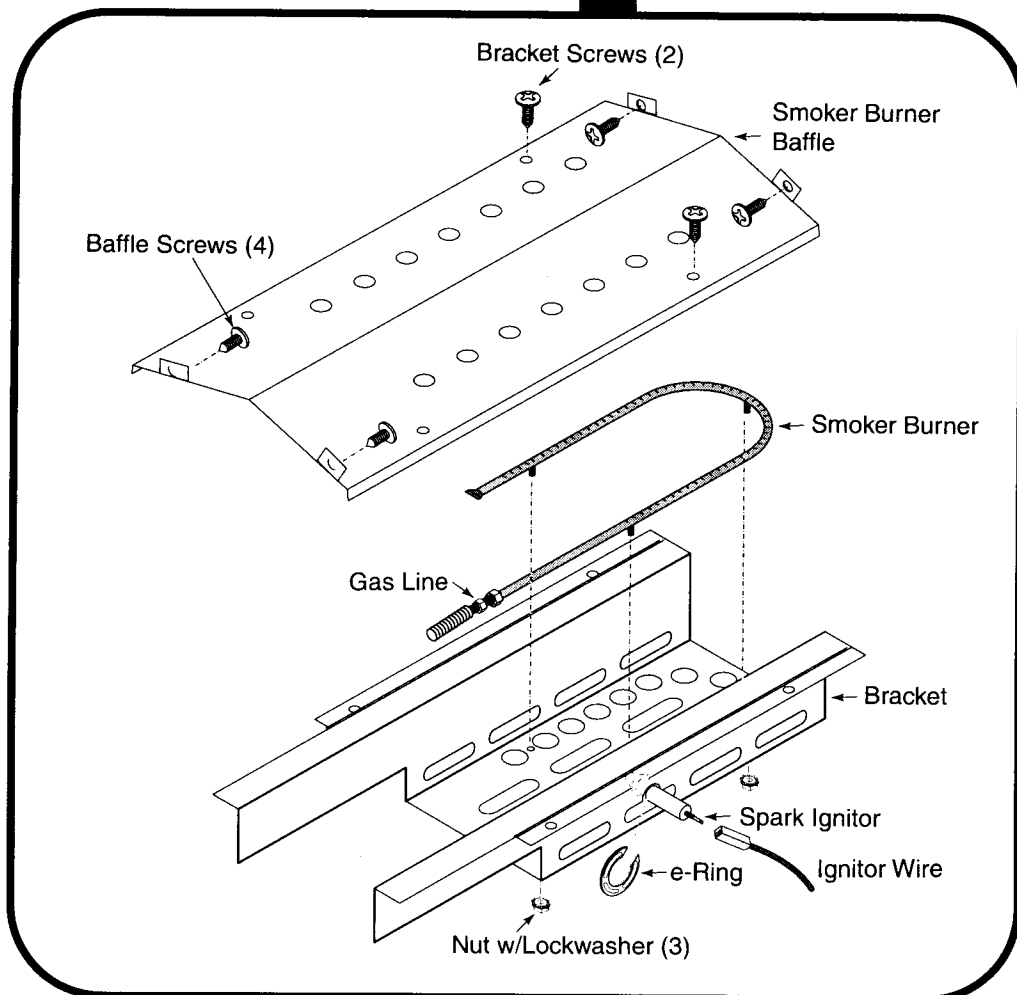

Figure 2



REMOVING THE INFRARED BURNER & HOT SURFACE IGNITOR

⚠ WARNING

Turn off the gas supply and disconnect the power cord from the AC outlet before servicing this unit.

⚠ CAUTION

When you work on the barbecue, be careful when handling the sheet metal parts. There are sharp edges present and you can cut yourself if you are not careful.

1. Turn off the gas supply and disconnect the electrical power going to the barbecue.
2. Lift the hood.
3. Remove the back cover from the barbecue.

Refer to Figure 3 for the following steps.

4. **To remove the infrared burner:**
 - a) Remove the hex nut from the gas line fitting and remove it from the bracket.
 - b) Remove the two mounting screws from the burner and remove it.
5. **To remove the hot surface ignitor:**
 - a) Remove the twist-on connectors from the hot surface ignitor wires and untwist the wires.
 - b) Remove the screw from the shield and remove the shield.
 - c) Remove the mounting screws and flat washers from the hot surface ignitor and remove the ignitor.

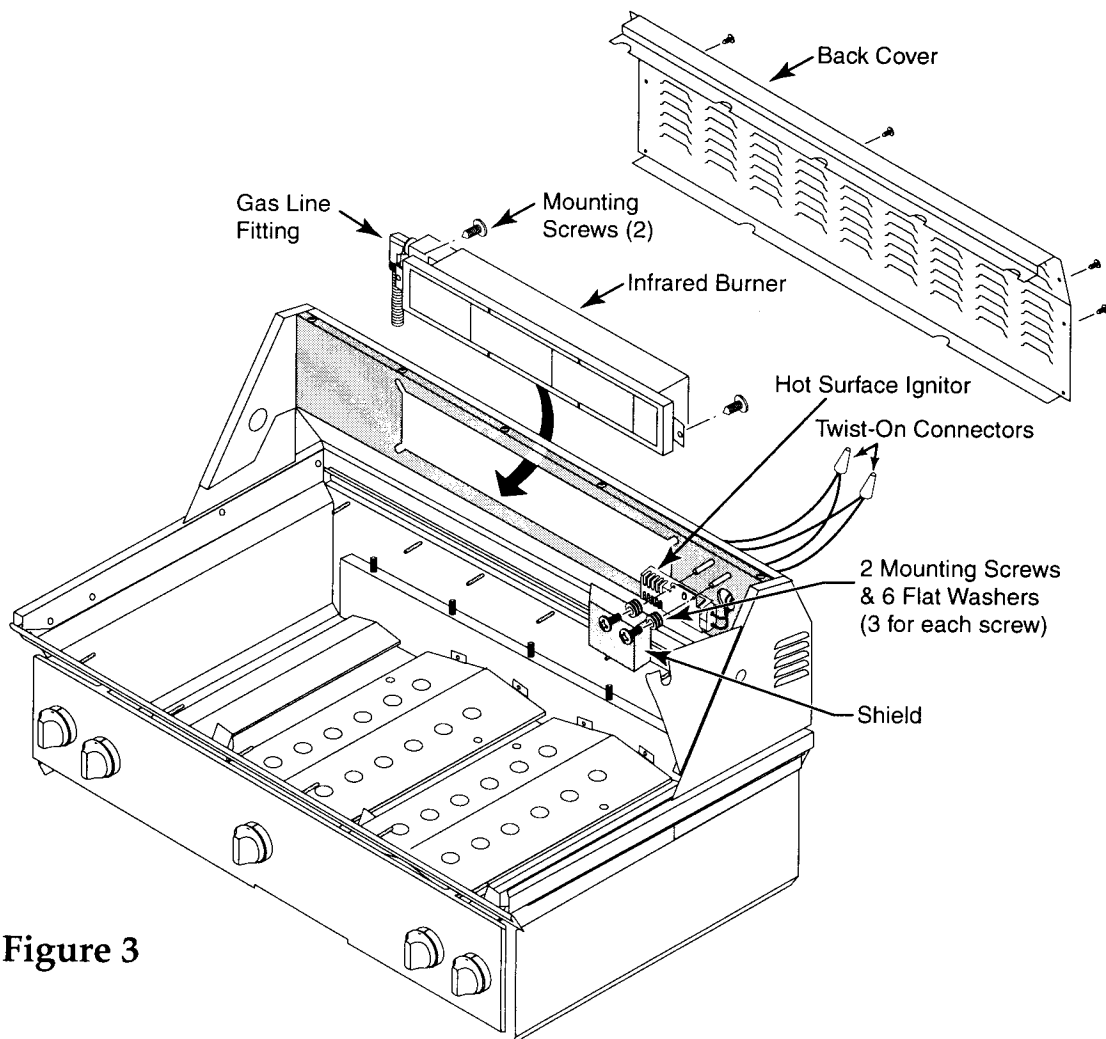

Figure 3

REMOVING THE FRONT PANEL & BULLNOSE

⚠ WARNING

Turn off the gas supply and disconnect the power cord from the AC outlet before servicing this unit.

⚠ CAUTION

When you work on the barbecue, be careful when handling the sheet metal parts. There are sharp edges present and you can cut yourself if you are not careful.

1. Turn off the gas supply and disconnect the electrical power going to the barbecue.
2. Lift the hood.
3. Remove the smoker tray and the drip pan.

Refer to Figure 4 for the following steps.

4. Remove the five knobs from the control stems.
5. Remove the larger mounting screw from each of the three center (main burner) bezels. Do not remove the two smaller bezel mounting screws.
6. Open the left and top right drawers as far as they will go.
7. Remove the two screws and flat washers from the bottom ends of the front panel.
8. Pull the front panel straight forward off the control stems and set it face up on the left drawer. Be careful not to scratch the panel.
9. Remove the four screws (2 on each side) from the bullnose and remove it from the barbecue.

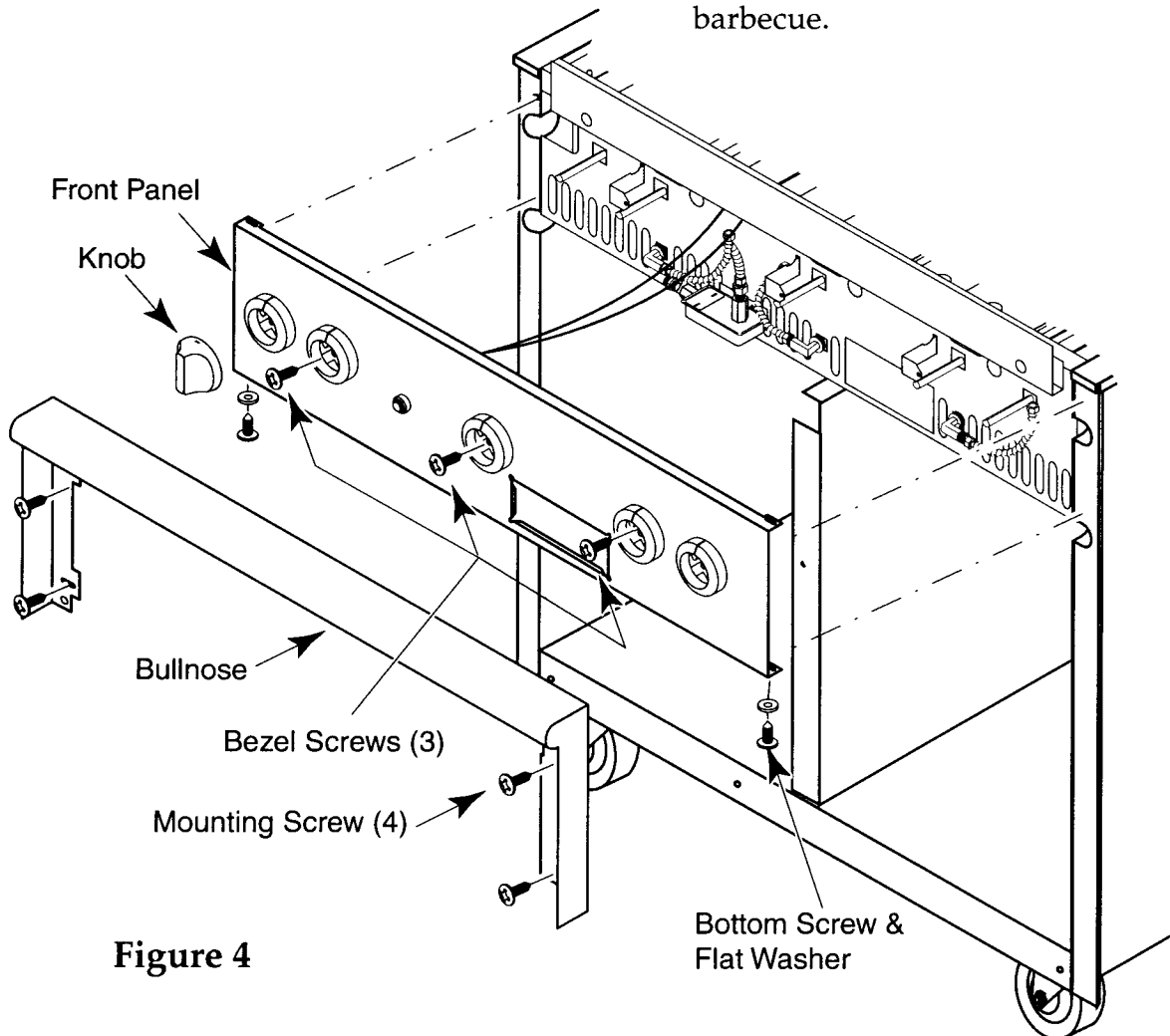

Figure 4

REMOVING A BURNER CONTROL VALVE, SAFETY VALVE, PRESSURE REGULATOR, & SWITCH

WARNING

Turn off the gas supply and disconnect the power cord from the AC outlet before servicing this unit.

CAUTION

When you work on the barbecue, be careful when handling the sheet metal parts. There are sharp edges present and you can cut yourself if you are not careful.

1. Turn off the gas supply and disconnect the electrical power going to the barbecue.
2. Lift the hood.
3. Remove the front panel (see page 2-7 for the procedure).

Refer to Figure 5 for the following steps.

4. **To remove a burner control valve:**
 - a) Remove the gas line from the valve fitting.
 - b) Remove the two screws from the manifold clamp and pull the valve off the manifold.
 - c) If you are replacing the control valve for the infrared burner, remove the two switch wires from the terminals.

IMPORTANT NOTE: Make sure to replace the valve with the type shown in the illustration on the next page.

5. **To remove the safety valve (see the small inset):**
 - a) Remove the two gas lines.
 - b) Remove the two wires from the terminals.
 - c) Remove the two hex nuts w/lockwashers from the studs and remove the valve from the bracket.
6. **To remove the pressure regulator:**
 - a) Open the left drawer as far as possible.
 - b) Remove the gas hose connector from the regulator.
 - c) Grip the hose (hex) end of the regulator with a 1-1/2" adjustable or open-end wrench, and twist it off the end of the manifold.
7. **To remove the switch from the infrared burner control valve:**
 - a) Disconnect the wires from the switch terminals.
 - b) Remove the mounting screw and pull the switch off the valve.

REASSEMBLY NOTE: When you make a gas line connection, use an approved thread sealant, (such as Loctite® 592), on the manifold threads, and then leak check the connection.

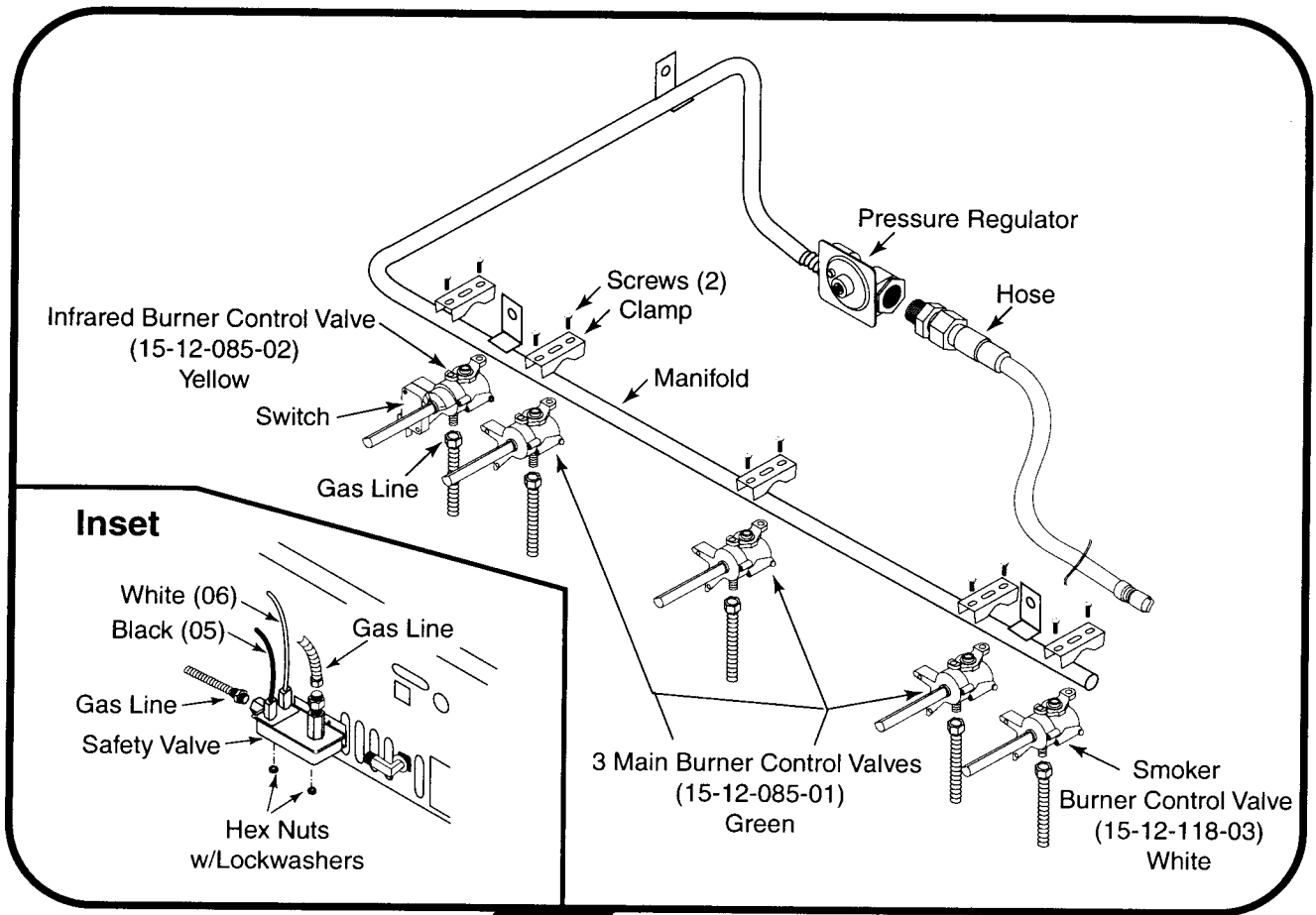
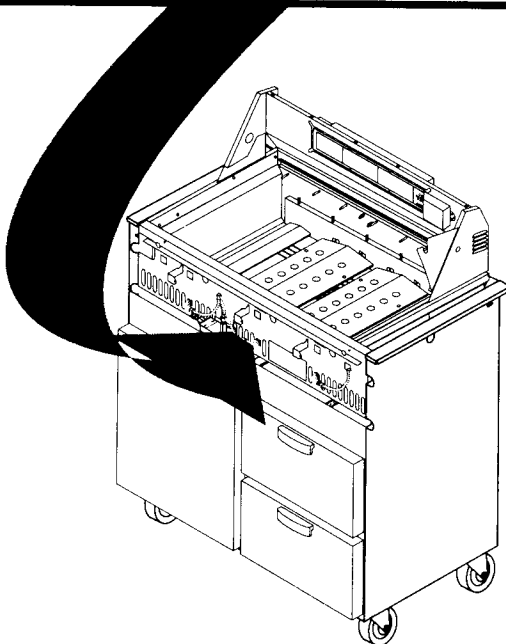

Figure 5



REMOVING THE IGNITOR SWITCH

WARNING

Turn off the gas supply and disconnect the power cord from the AC outlet before servicing this unit.

CAUTION

When you work on the barbecue, be careful when handling the sheet metal parts. There are sharp edges present and you can cut yourself if you are not careful.

1. Turn off the gas supply and disconnect the electrical power going to the barbecue.
2. Remove the front panel from the barbecue (see page 2-7 for the procedure).

Refer to Figure 6 for the following steps.

3. Disconnect the two wires from the ignitor switch terminals.
4. Push in on the locking arms on the sides of the ignitor switch body and push the switch out of the hole in the front panel.

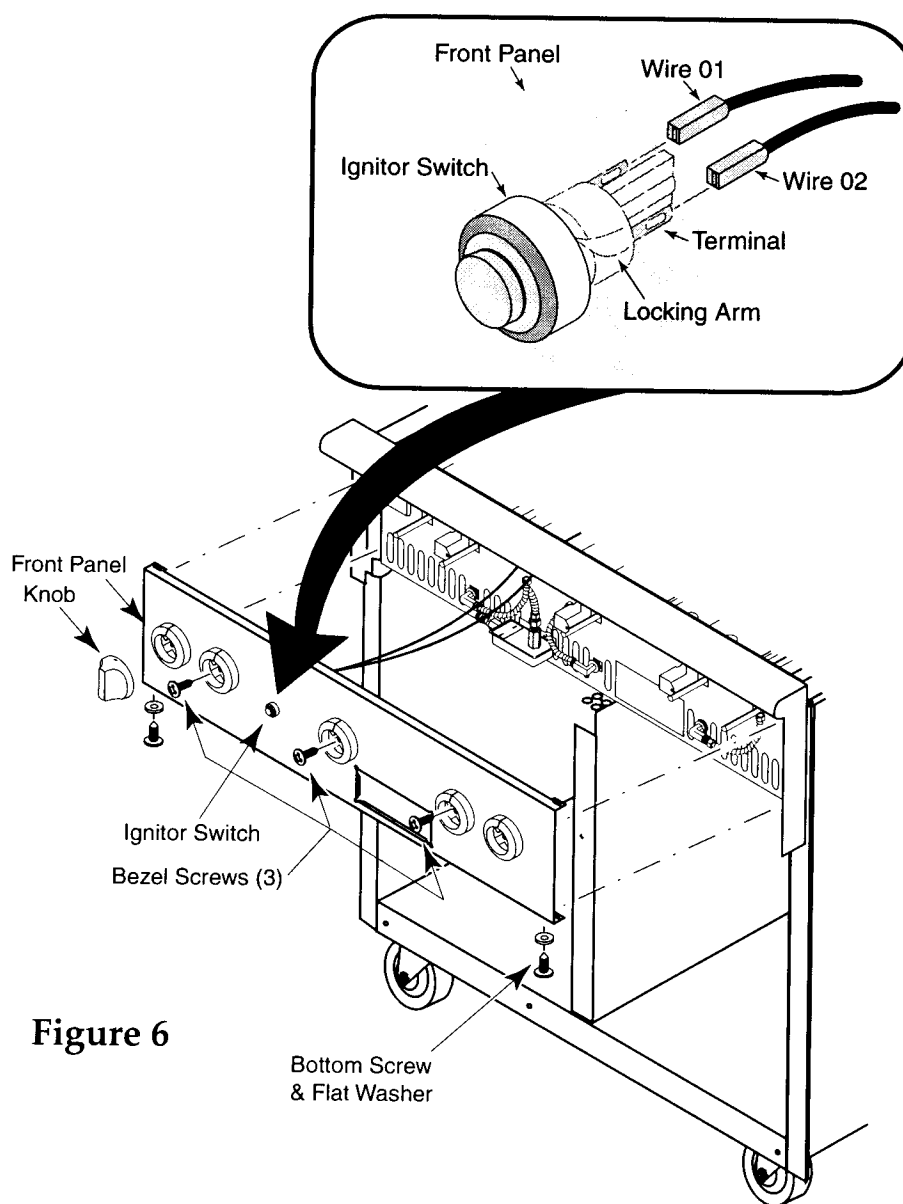

Figure 6

REMOVING THE SPARK MODULE & TERMINAL BLOCK

⚠ WARNING

Turn off the gas supply and disconnect the power cord from the AC outlet before servicing this unit.

⚠ CAUTION

When you work on the barbecue, be careful when handling the sheet metal parts. There are sharp edges present and you can cut yourself if you are not careful.

1. Turn off the gas supply and disconnect the electrical power going to the barbecue.
2. Open the three drawers as far as possible.

Refer to Figure 7 for the following steps.

3. Remove the two screws from the ignitor box and position it so you can access the components.
4. To remove the spark module or terminal block, remove the two screws and hex nuts w/lockwashers, and disconnect the wires from the terminals.

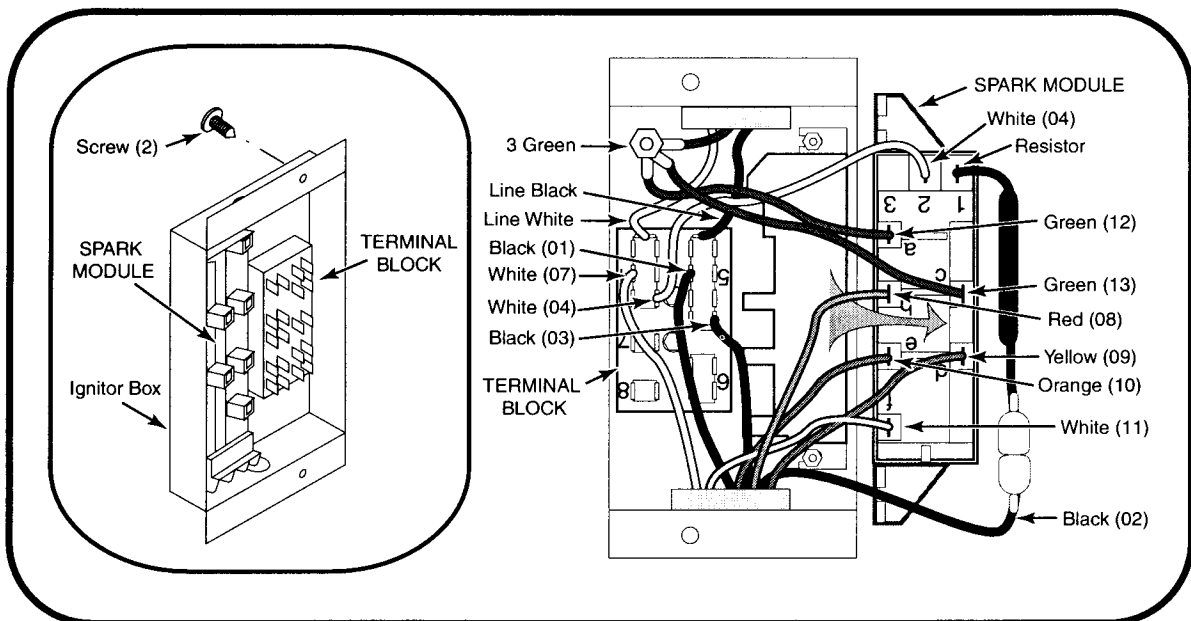

Figure 7

REMOVING A DRAWER FRONT ASSEMBLY, HANDLE, THERMOMETER, HOOD, CASTER, & KICK PANEL

WARNING

Turn off the gas supply and disconnect the power cord from the AC outlet before servicing this unit.

CAUTION

When you work on the barbecue, be careful when handling the sheet metal parts. There are sharp edges present and you can cut yourself if you are not careful.

1. Turn off the gas supply and disconnect the electrical power going to the barbecue.

Refer to Figure 8 for the following steps.

2. **To remove a drawer front assembly:**
 - a) Open the drawer that you wish to service.

NOTE: When you remove the front of the drawer in the next step, hold the front to keep it from falling as you remove the mounting screws.

- b) Remove the screws that hold the drawer front assembly to the drawer and remove the assembly.
- c) Remove the screws from the rear panel and remove it from the assembly.
- d) Remove the two screws from the drawer handle and remove the handle.

3. **To remove the front panel and handle from the smoker tray,** remove the two screws from the back of the panel.
4. **To remove the handle and end cap assembly from the hood:**
 - a) Remove the four screws from the inside of the hood.
 - b) Remove the end cap screws and remove the end caps from the handle.
5. **To remove the hood from the barbecue,** remove the two shoulder bolts and acorn nuts.
6. **To remove the thermometer,** remove the two screws from the inside of the hood.
7. **To remove a caster,** remove the four screws from the bottom of the barbecue.
8. **To remove the kick panel,** remove the four screws.

NOTE: The drip tray is one unit and is non-serviceable.

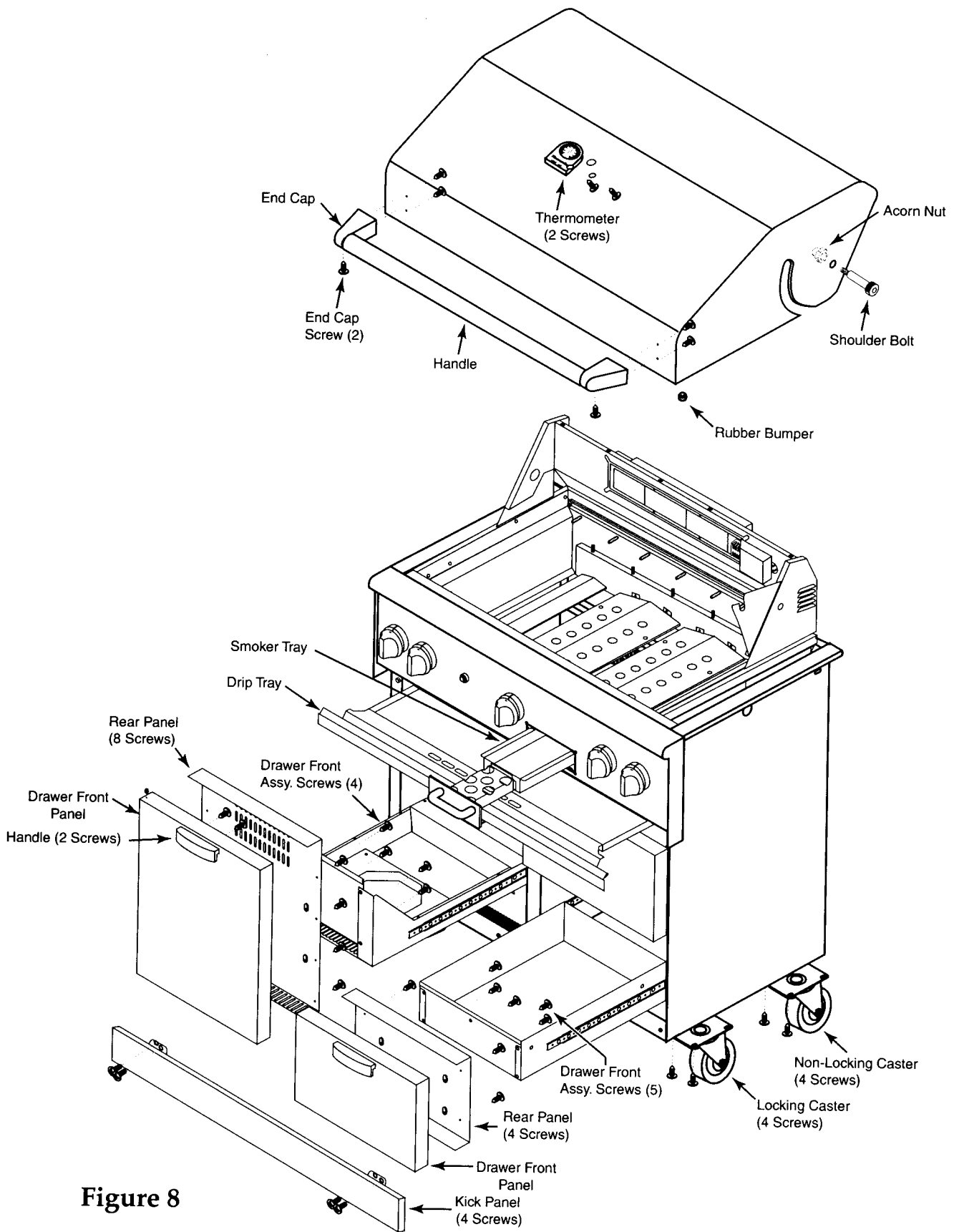

Figure 8

REMOVING A BURNER BASE, JET HOLDER, IGNITOR PLUG, SPARK MODULE, TERMINAL BLOCK, & RESISTOR (48" MODELS ONLY)

WARNING

Turn off the gas supply and disconnect the power cord from the AC outlet before servicing this unit.

CAUTION

When you work on the barbecue, be careful when handling the sheet metal parts. There are sharp edges present and you can cut yourself if you are not careful.

1. Turn off the gas supply and disconnect the electrical power going to the barbecue.

Refer to Figure 9 for the following steps.

2. To remove a burner base:

- a) Remove the grate and burner cap from over the side burners.
- b) Remove the venturi nut from the burner you wish to service.
- c) Remove the burner base from the drip tray.

3. To remove a jet holder:

- a) Remove both burner bases from the drip tray (refer to step 2).
- b) Lift the drip tray off the burner mounting channel and position it out of the way.
- c) Remove the nut from the jet holder.
- d) Remove the gas line from the jet holder and remove the jet holder.

4. To remove an ignitor plug:

- a) Remove both burner bases from the drip tray (refer to step 2).
- b) Lift the drip tray off the burner mounting channel and disconnect the ignitor wire from the ignitor terminal.
- c) Remove the clip from the ignitor plug and remove the ignitor plug from the drip tray.

5. To remove the spark module, terminal block, or resistor:

- a) Remove the front panel.
- b) Remove the two screws from the cover and turn the cover over.
- c) Remove the two screws from the spark module or the terminal block and disconnect the wires from the terminals.
- d) Disconnect the leads of the resistor from the wire terminals.

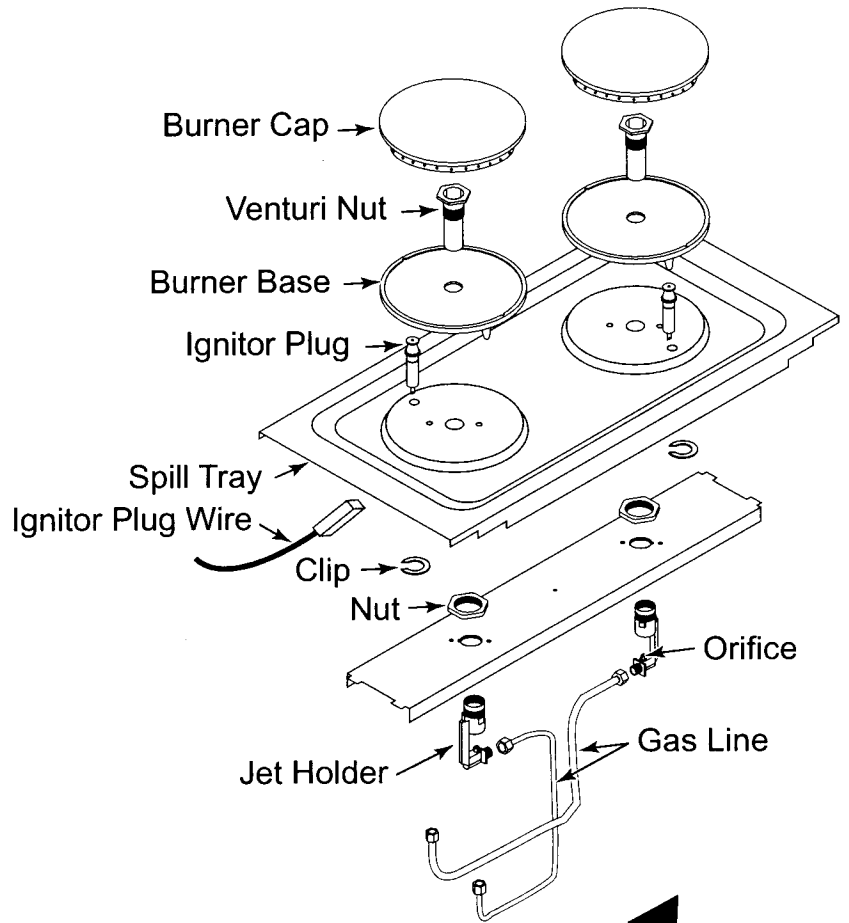

48" Models Only

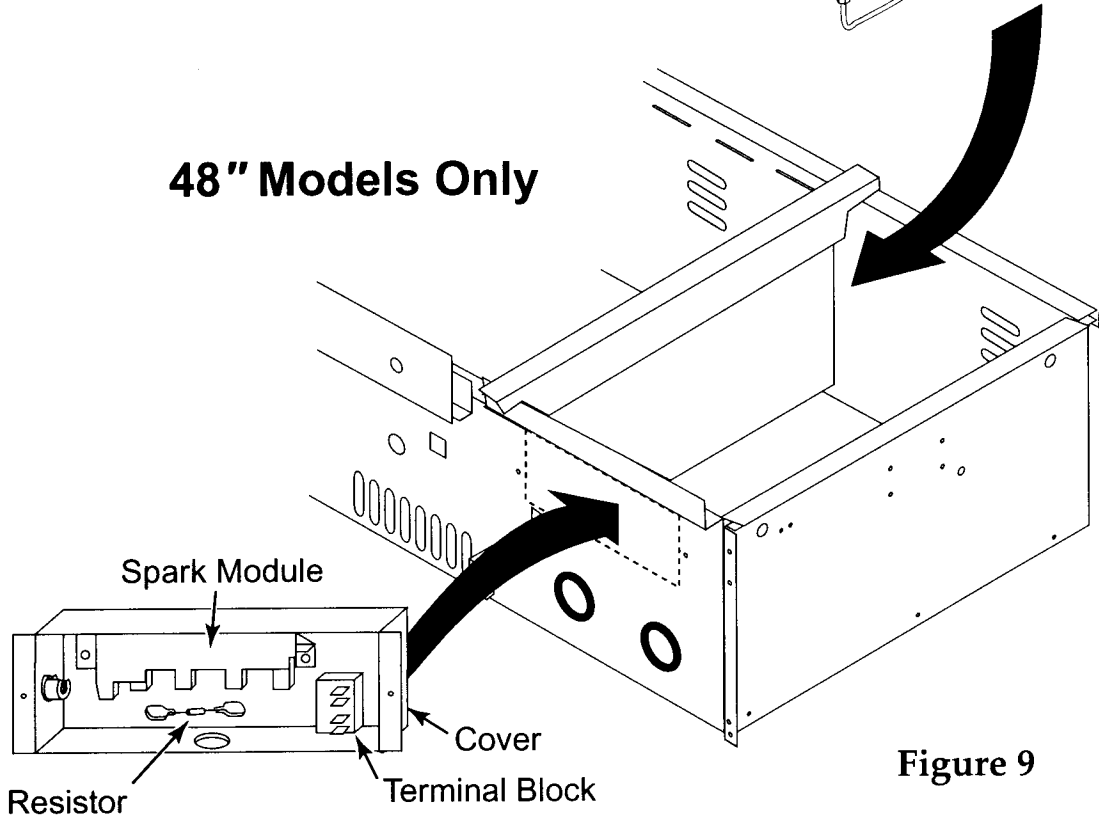

Figure 9

REMOVING A BURNER ORIFICE

⚠ WARNING

Turn off the gas supply and disconnect the power cord from the AC outlet before servicing this unit.

⚠ CAUTION

When you work on the barbecue, be careful when handling the sheet metal parts. There are sharp edges present and you can cut yourself if you are not careful.

1. Turn off the gas supply and disconnect the electrical power going to the barbecue.

Refer to Figure 10 for the following steps.

2. **To remove any of the three main burner orifices:**

- a) Remove the burner and front panel (see pages 2-2 and 2-7 for the procedures).
- b) Use a 1/2" open-end or adjustable wrench and remove the burner orifice from the fitting. The replacement orifices for the three burners are as follows:

Natural Gas—.0810 (#46 drill)

L.P. Gas—.0550 (#54 drill)

3. **To remove the infrared burner orifice:**

- a) Remove the back cover from the barbecue.
- b) Use a 1/2" open-end or adjustable wrench, and remove the burner orifice from the fitting. The replacement orifices for the infrared burner are as follows:

Natural Gas—.0595 (#53 drill)

L.P. Gas—.0410 (#59 drill)

4. **To remove the smoker burner orifice:**

- a) Remove the smoker tray.
- b) Use a 1/2" open-end or adjustable wrench, and remove the burner orifice from the fitting. The replacement orifices for the smoker burner are as follows:

Natural Gas—#63

L.P. Gas—#73

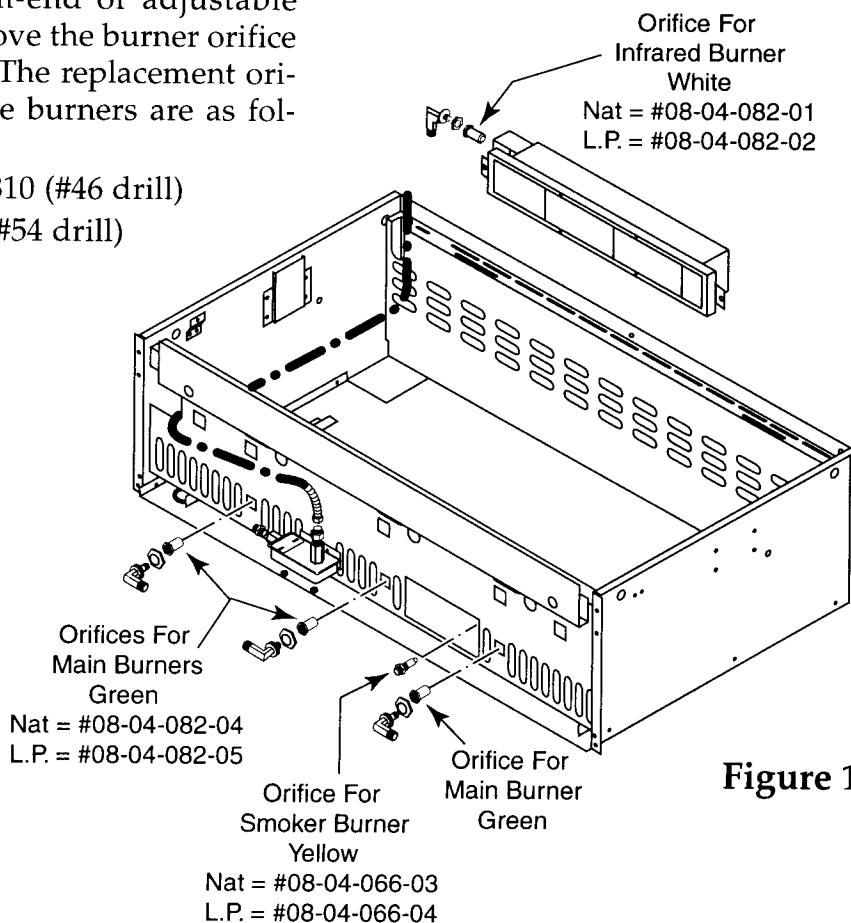

Figure 10

TROUBLESHOOTING

TESTING THE COMPONENTS

Resistance Measurements

⚠ WARNING

TO AVOID ELECTRICAL SHOCK
DISCONNECT THE POWER TO THE
APPLIANCE BEFORE TESTING.

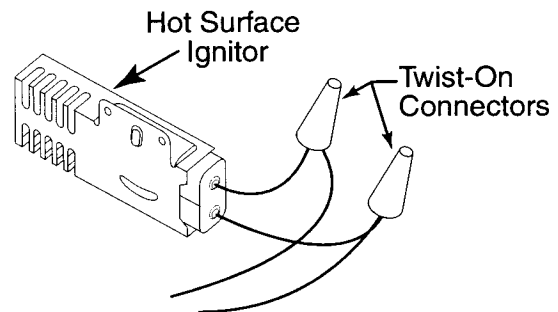
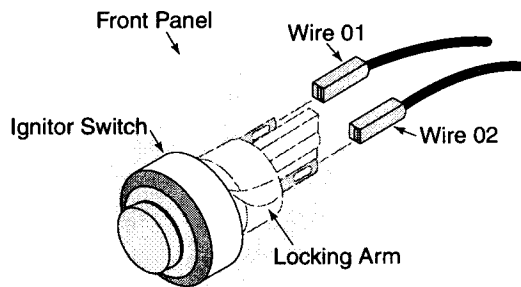

IGNITOR SWITCH

To test an ignitor switch, perform the following steps (see page 2-10 to access the switch):

1. Turn off the gas supply and electrical power to the barbecue.
2. Remove the front panel to access the ignitor switch (see page 2-7 for the procedure).
3. Disconnect one of the wires from the switch.
4. Set the ohmmeter to the $R \times 1$ scale.
5. Touch the meter leads to the switch terminals. The meter should indicate infinity (open).
6. Press the ignitor switch button and the meter should indicate a short (closed contacts).
7. If the readings are not correct, the switch is defective and should be replaced.

HOT SURFACE IGNITOR

To test the hot surface ignitor for the rotisserie, perform the following steps (see page 2-6 to access the ignitor):

1. Turn off the gas supply and electrical power to the barbecue.
2. Remove the back cover from the barbecue to access the hot surface ignitor.
3. Disconnect one of the wires from the hot surface ignitor.
4. Set the ohmmeter to the $R \times 1$ scale.
5. Touch the meter leads to the bare lead ends of the hot surface ignitor. The meter should indicate between 40Ω and $400 \Omega @ 75^\circ\text{F}$.
6. If the readings are not within the indicated range, the ignitor is defective and should be replaced.

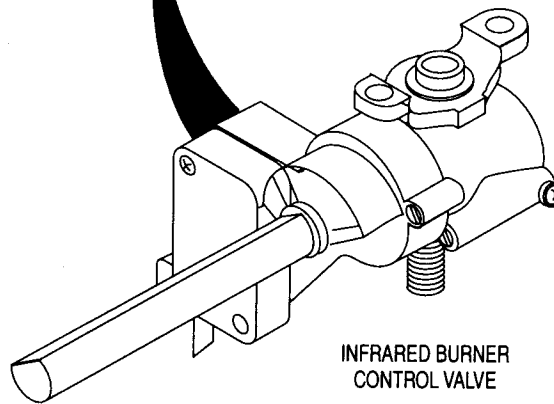
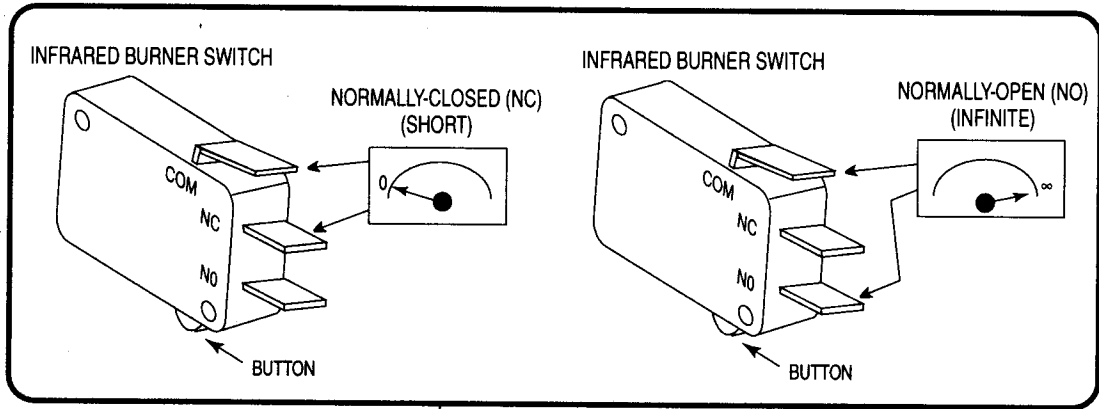

INFRARED BURNER
CONTROL VALVE

INFRARED BURNER SWITCH

To test an infrared burner switch, perform the following steps (see page 2-8 to access the switch):

1. Turn off the gas supply and electrical power to the barbecue.
2. Remove the front panel to access the switch (see page 2-7 for the procedure).
3. Disconnect one of the wires from the switch.
4. Set the ohmmeter to the R x 1 scale.
5. Touch the meter leads to the NO and COM switch terminals and the meter should indicate infinity (open).
6. Press the switch button and the meter should indicate a short (closed contacts).
7. Touch the meter leads to the NC and COM switch terminals and the meter should indicate a short (closed contacts).
8. Press the switch button and the meter should indicate infinity (open).
9. If the readings are not correct, the switch is defective and should be replaced.

OPERATIONAL TESTS

THE BURNERS FAIL TO IGNITE

1. Make sure that the unit is connected to a properly grounded duplex outlet.
2. If electricity is present, look for a spark from the spark ignitor to the burner when the ignition switch is depressed and held.
3. Make sure that the spark ignitors and burners are clean and dry.
4. On Model **CGB48RSBU**, verify that the side burner caps are properly installed on their burner bases.

THE ROTISSERIE MOTOR DOES NOT WORK

1. Make sure that the motor is connected to a properly grounded duplex outlet.
2. Make sure that the skewer is fully engaged in the motor drive shaft.

SERVICE INFORMATION

The Serial Number/Data sticker (see page 1-1) shows the model and serial number for your barbecue. It also gives information regarding burner rating and installation requirements.

— NOTES —

WIRING DIAGRAMS

MODEL CGB30RCLP

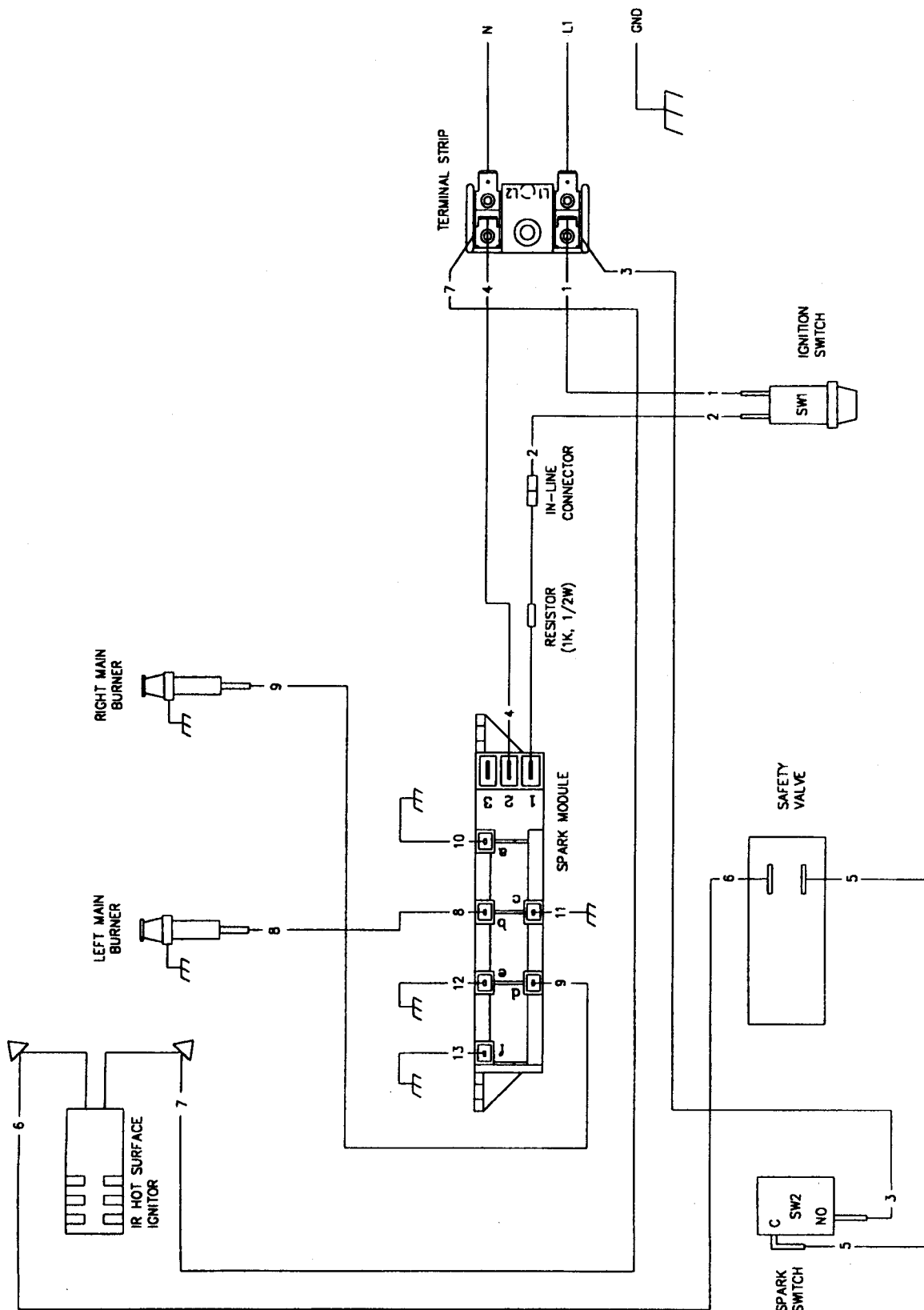

Part No. 08-04-352, Rev. B

MODEL CGB36R

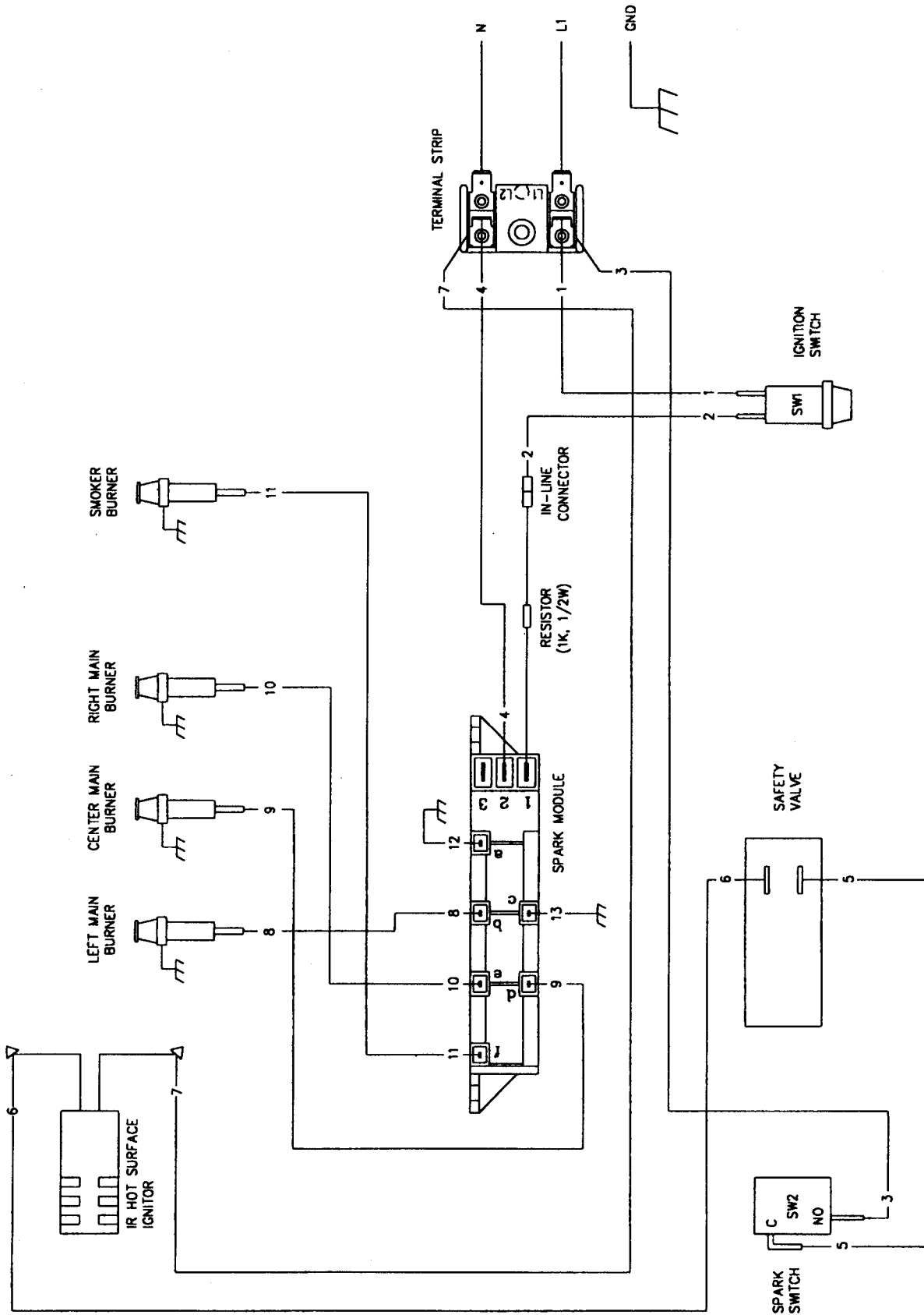

MODEL CGB48RSB

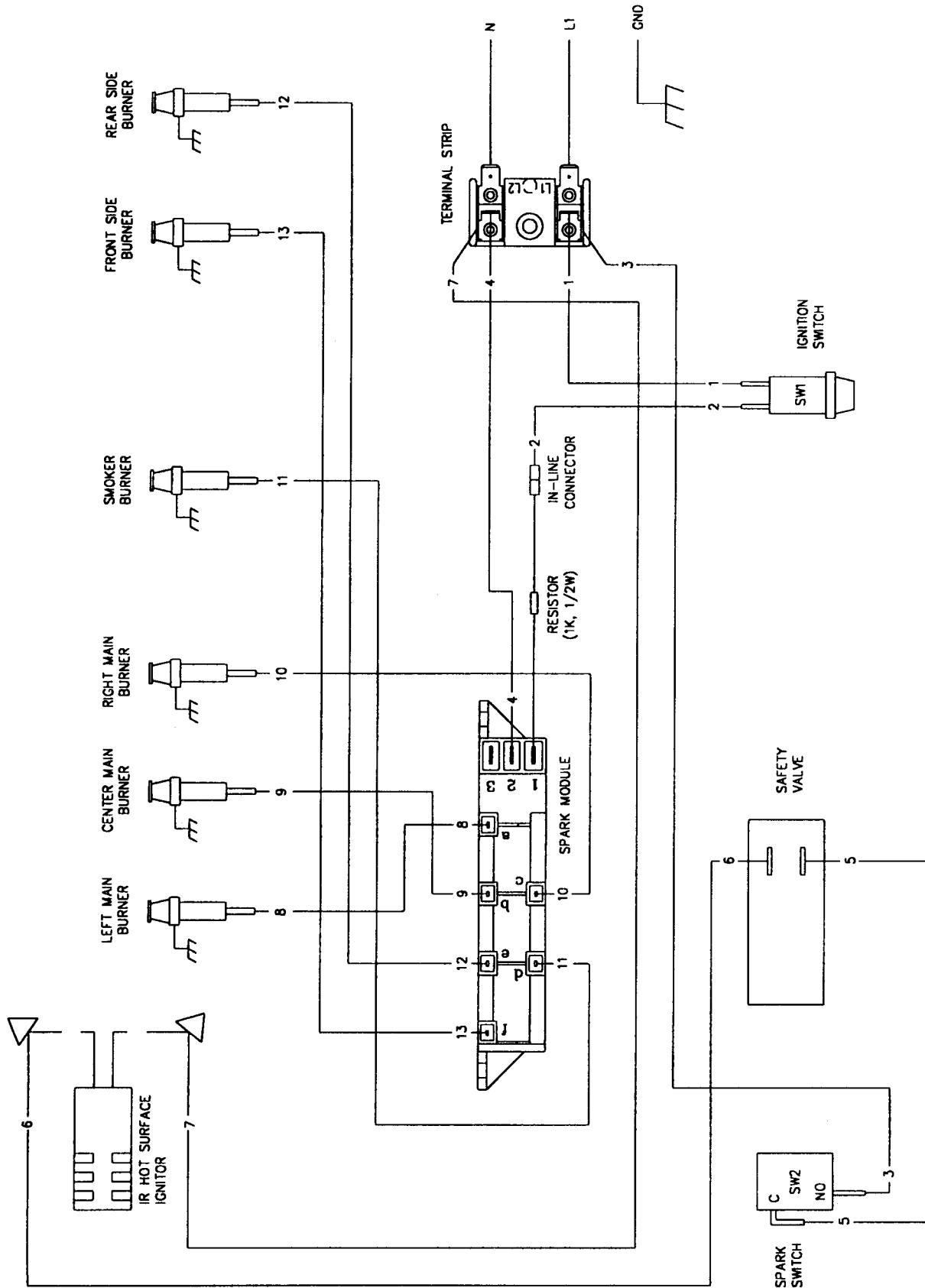

— NOTES —