



# Service Manual

## Electric Slide-in Range



 **Electrolux**

318 202 118 (0711)

# Table of Contents

<b>SAFE SERVICING PRACTICES .....</b>	<b>1</b>
<b>PRODUCT FEATURES .....</b>	<b>2-3</b>
<b>WIRING DIAGRAM .....</b>	<b>4-5</b>
<b>SECTION A - INSTALLATION INSTRUCTIONS .....</b>	<b>6</b>
CLEARANCE AND DIMENSIONS .....	6-8
IMPORTANT NOTES TO THE INSTALLER .....	9
IMPORTANT NOTE TO THE CONSUMER .....	9
IMPORTANT SAFETY INSTRUCTIONS .....	9
1. POWER SUPPLY CORD KIT (U.S.A.) .....	10
2. FACTORY CONNECTED POWER SUPPLY CORD (CANADA ONLY) .....	10
3. ELECTRICAL CONNECTION TO RANGE (U.S.A.) .....	11-13
4. CABINET CONSTRUCTION .....	13
5. RANGE INSTALLATION .....	14
6. LEVELING THE RANGE .....	15
7. CHECK OPERATION .....	15
8. ANTI-TIP BRACKET INSTALLATION .....	16
<b>SECTION B - ELECTRONIC OVEN CONTROL .....</b>	<b>17</b>
OVEN CONTROL PAD FUNCTIONS .....	17-19
SETTING THE CLOCK AT POWER UP .....	20
CONTROL PANEL DISPLAY MODES .....	20
TEMPERATURE VISUAL DISPLAY .....	20
OVEN LIGHT .....	21
CONTROL LOCK .....	21
SETTING THE KITCHEN TIMER .....	21
BAKING .....	22
COOK TIME .....	23
END TIME .....	23
BROILING .....	24
CONVECTION BAKING .....	25
CONVECTION CONVERT .....	26
RAPID PREHEAT .....	26
CONVECTION ROASTING .....	27
CONVECTION BROILING .....	28
KEEP WARM .....	29
SLOW COOK .....	30
DEHYDRATING .....	31
DEFROSTING .....	31

# Table of Contents



BREAD PROOFING .....	32
PERFECT TURKEY .....	33
TEMPERATURE PROBE .....	34
MULTI STAGE .....	35-36
USER PREFERENCES .....	37-39
MY FAVORITES .....	40
SABBATH FEATURE .....	41-42
STARTING SELF-CLEAN CYCLE .....	43

## **SECTION C - SERVICE DATA ..... 44**

ELECTRONIC OVEN CONTROL .....	44-46
CONVECTION MODE .....	47
CONVECTION FAN MOTOR .....	47
OVEN CALIBRATION .....	48
FIRST RISE .....	48
ELECTRONIC OVEN CONTROL - FAULT CODES .....	48-49
ELECTRONIC SURFACE ELEMENT CONTROL - FAULT CODE DESCRIPTIONS .....	49
RTD SCALE .....	50
ELECTRICAL RATING .....	50
ELECTRIC SLIDE-IN OVEN CIRCUIT ANALYSIS MATRIX .....	50
EXPLODED VIEW OF CONVECTION SYSTEM .....	51
FAN BLADE .....	51
MOUNTING PLATE OVEN .....	51
COOLING FAN MOTOR .....	51
MEAT PROBE RESISTANCE .....	52
OVEN DOOR REMOVAL AND REPLACEMENT .....	52
TRUE HIDDEN BAKE ELEMENT REMOVAL .....	53
DOOR LOCK MECHANISM .....	53
OVEN LIGHT .....	54
BLOCK DIAGRAM AND SYSTEM INTERCONNECTIONS .....	55



# Table of Contents

---

## **SECTION D - REPLACEMENT OF PARTS ..... 56**

1.0	HOW TO ACCESS THE CONTROL PANEL AND COOKTOP AREA .....	56-60
2.0	HOW TO ACCESS THE CONTROL PANEL AREA (ELECTRONIC OVEN AND SURFACE CONTROLS) .....	60-61
3.0	DOOR LOCK ASSEMBLY .....	61-62
4.0	HALOGEN LIGHT SOCKET, HINGE RECEPTACLE AND RACK SENSOR .....	63-65
5.0	OVEN RACKS, LADDER RACKS AND HALOGEN LIGHT .....	65-66
6.0	MEAT PROBE .....	67
7.0	OVEN TEMPERATURE SENSOR .....	68
8.0	BROIL ELEMENT .....	68
9.0	CONVECTION ELEMENT .....	69-72
10.0	UNIT BACK VIEW AND COMPONENTS .....	72
11.0	HIDDEN BACK AND MINI OVEN ELEMENT .....	73-76
12.0	MINI OVEN LIGHT AND GLIDES .....	76-77
13.0	MINI OVEN DRAWER ASSEMBLY .....	77-79
14.0	COMPLETE MAIN OVEN DOOR ASSEMBLY .....	79-82

## **SECTION E - EXPLODED VIEW DRAWINGS .....**

CONTROL PANEL EXPLODED VIEW .....	
CONTROL PANEL PART DESCRIPTION .....	
BODY EXPLODED VIEW .....	
BODY PART DESCRIPTION .....	
DOOR EXPLODED VIEW .....	
DOOR PART DESCRIPTION .....	

---

# SAFE SERVICING PRACTICES 1

To avoid personal injury and/or property damage, it is important that **Safe Servicing Practices** be observed. The following are some limited examples of safe practices:

1. **DO NOT** attempt a product repair if you doubt your ability to complete it in a safe and satisfactory manner.
2. Before servicing or moving an appliance:
  - Remove power cord from electrical outlet, trip circuit breaker to the **OFF** position, or remove fuse.
  - Turn off gas supply
  - Turn off water supply
3. Never interfere with the proper operation of any safety device.
4. **Use The Correct Replacement Parts Cataloged For This Appliance. Substitutions May Defeat Compliance With Safety Standards Set For Home Appliances.**
5. **GROUNDING:** The standard color code for safety ground wires is **GREEN**, or **GREEN** with **YELLOW STRIPES**. **DO NOT** use ground leads as current carrying conductors. It is **EXTREMELY** important that the service technician reestablish all safety grounds prior to completion of service. Failure to do so will create a hazard.
6. Prior to returning the product to service, ensure that:
  - All electrical connections are correct and secure.
  - All electrical leads are properly dressed and secured away from sharp edges, high-temperature components, and moving parts
  - All non-insulated electrical terminals, connectors, heaters, etc. are adequately spaced away from all metal parts and panels
  - All safety grounds (both internal and external) are correctly and securely connected
  - All panels are properly and securely reassembled



## WARNING

This service manual is intended for use by persons having electrical and mechanical training and a level of knowledge of these subjects generally considered acceptable in the appliance repair trade. Electrolux Home Products cannot be responsible, nor assume any liability, for injury or damage of any kind arising from the use of this manual.

## 2 Product Features

CERAMIC GLASS  
COOKTOP

TOUCH ACTIVATED  
GLASS CONTROL  
PANEL

LARGE METAL  
HANDLE

CURVED GLASS  
OVEN DOOR

LOWER OVEN  
DOOR WINDOW  
GLASS

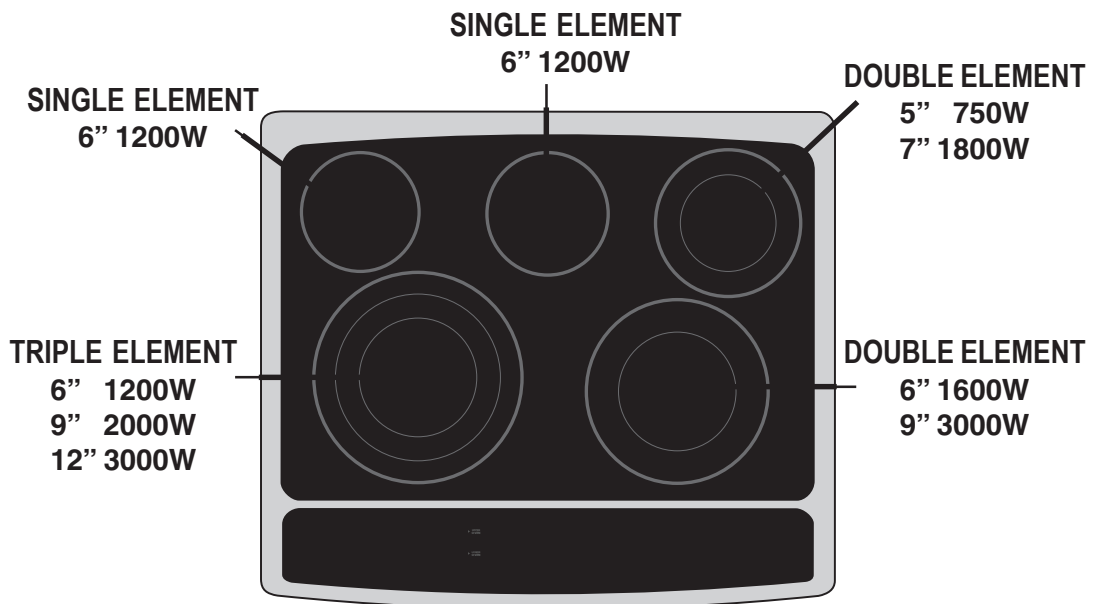
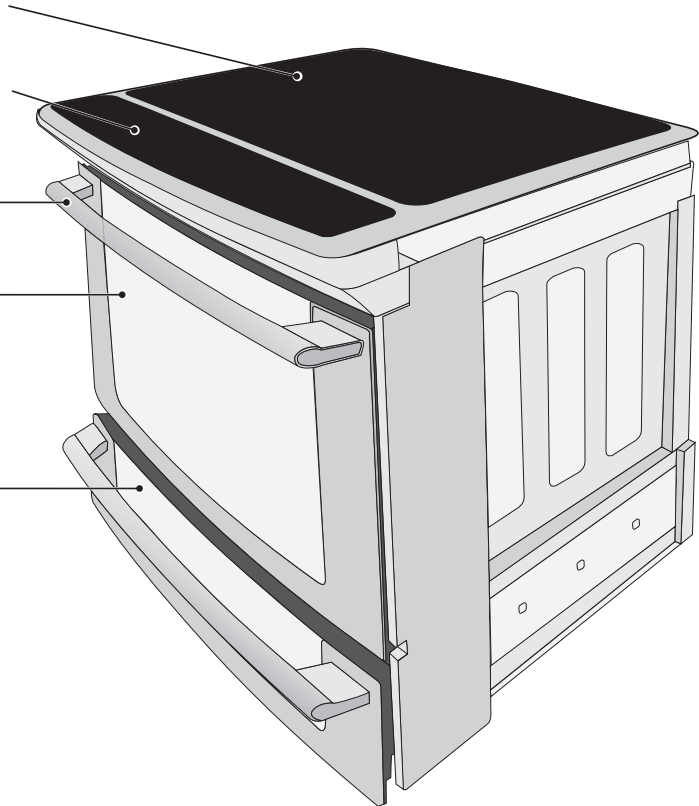

# Product Features 3

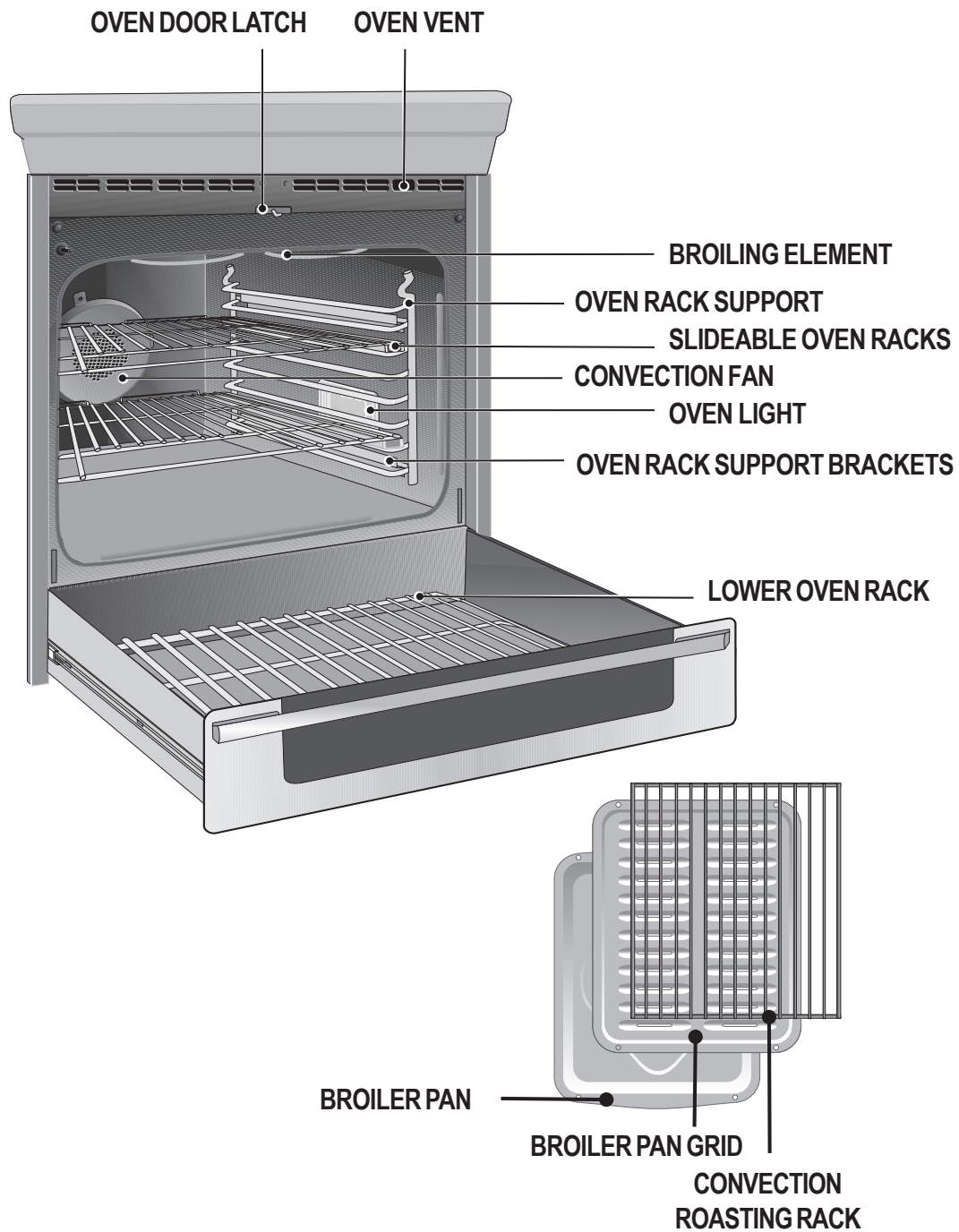

# 4 Wiring Diagram

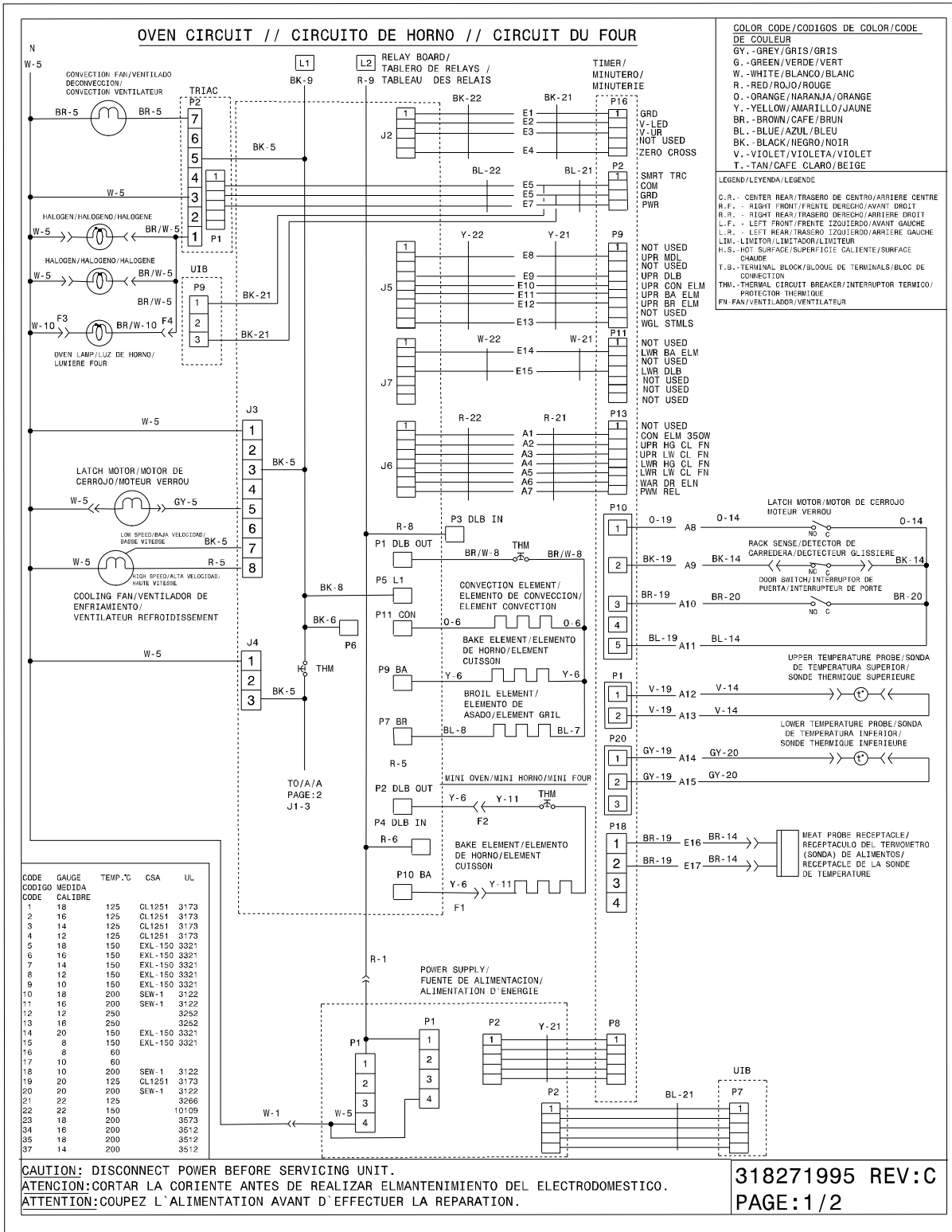



# Wiring Diagram 5

## COOKTOP CIRCUIT // CIRCUITO DE PLANCHA DE COCINAR // CIRCUIT TABLE CUISSON

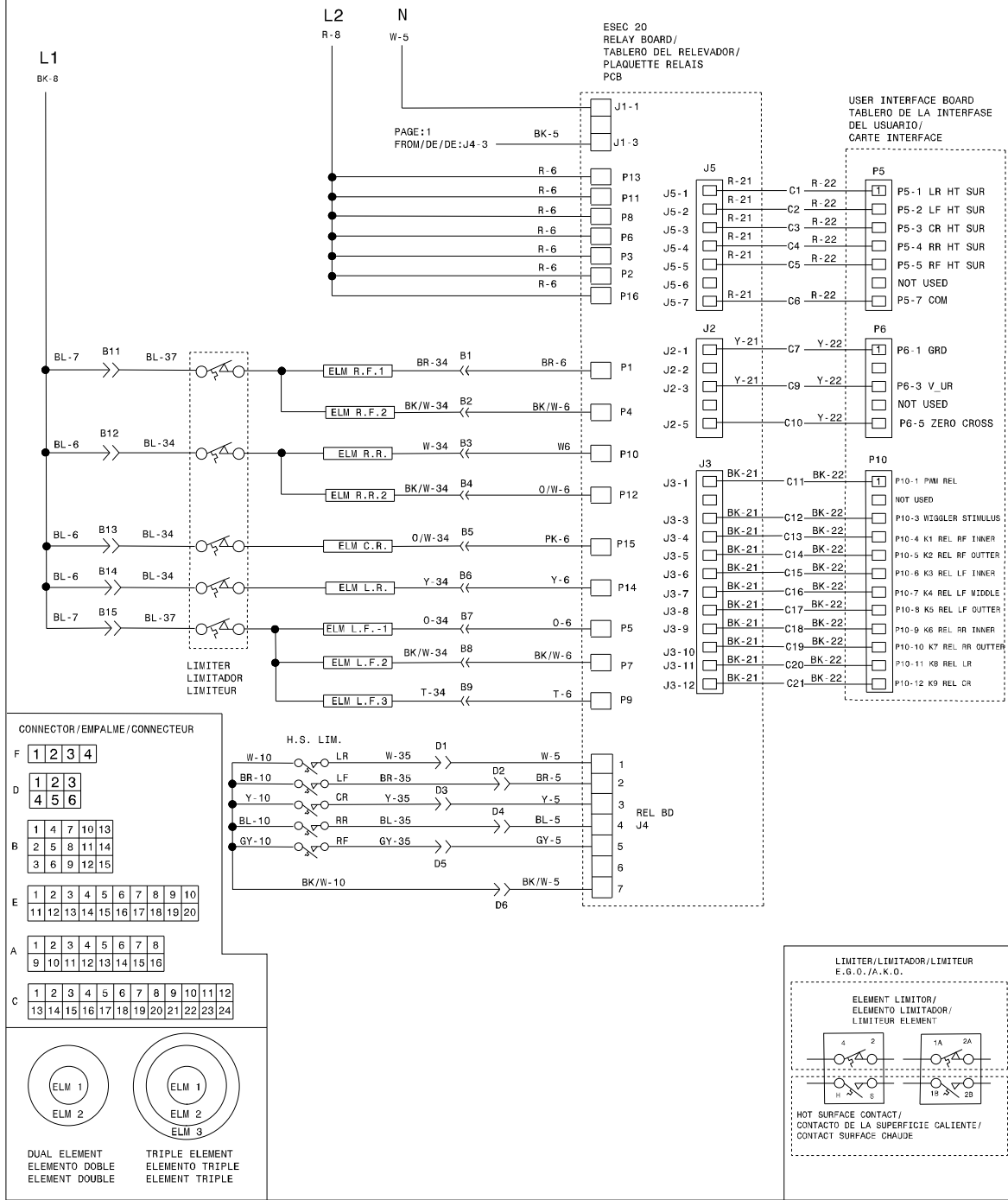

CAUTION: DISCONNECT POWER BEFORE SERVICING UNIT.  
 ATENCION: CORTAR LA CORRIENTE ANTES DE REALIZAR EL MANTENIMIENTO DEL ELECTRODOMESTICO.  
 ATTENTION: COUPEZ L'ALIMENTATION AVANT D'EFFECTUER LA REPARATION.

318271995 REV:C  
 PAGE: 2/2

# 6 Section A - Installation Instructions

**INSTALLATION AND SERVICE MUST BE PERFORMED BY A QUALIFIED INSTALLER.  
 IMPORTANT: SAVE FOR LOCAL ELECTRICAL INSPECTOR'S USE.  
 READ AND SAVE THESE INSTRUCTIONS FOR FUTURE REFERENCE.**

For existing 29" (73.7 cm) cutout wide opening, you must call the Service Center for optional thinner side trims. Also you must prepare the countertop edge as shown in the "Countertop Preparation" section (see page 8).

**These surfaces should be flat & leveled (hatched area).**

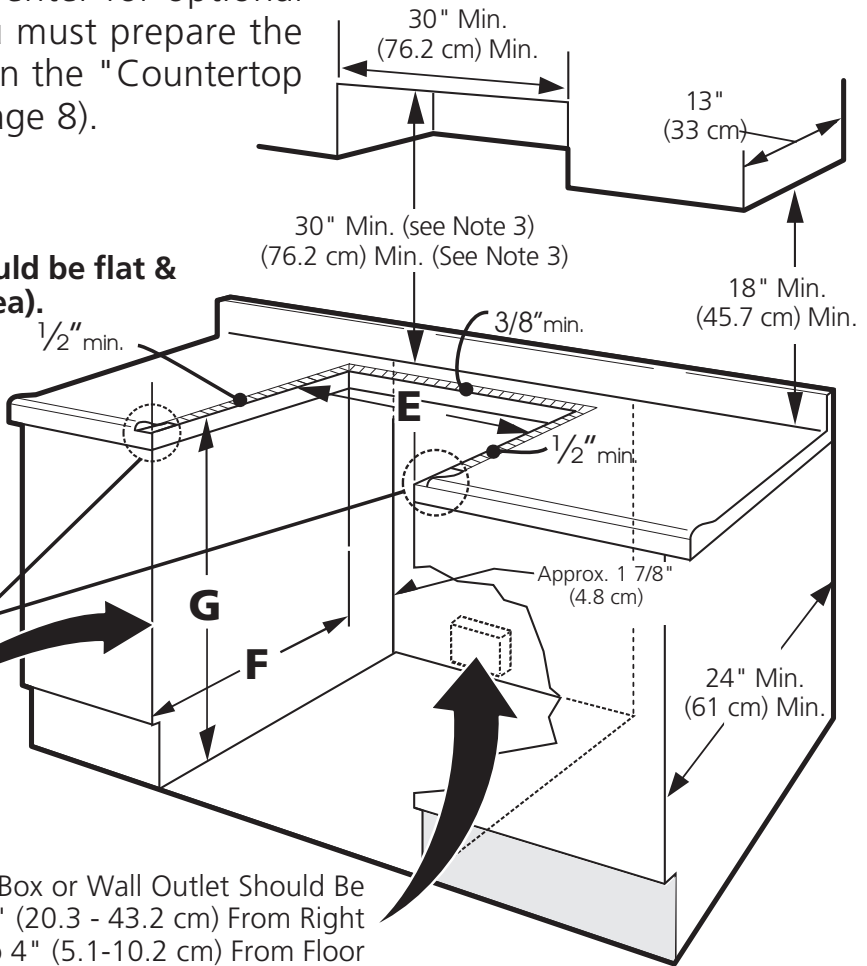
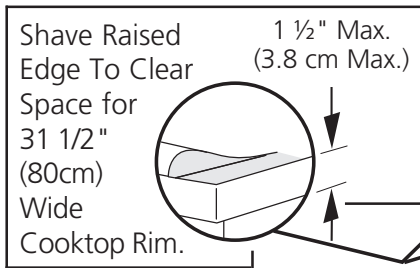

Locate Cabinet Doors 1" (2.5 cm) Min. From Cutout Opening

Grounded Junction Box or Wall Outlet Should Be Located 8" to 17" (20.3 - 43.2 cm) From Right Cabinet and 2" to 4" (5.1-10.2 cm) From Floor

**IMPORTANT:**  
 Cabinet and countertop width should match the cutout width.

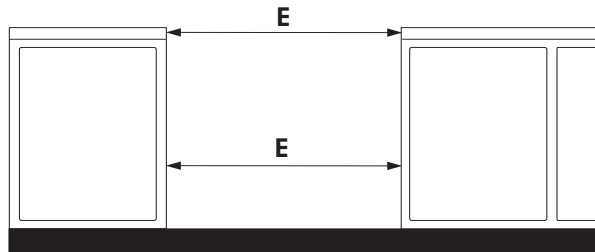

**⚠ WARNING Do not install the unit in the cabinet before reading next two pages.**

A. HEIGHT (Under Cooktop)	B. WIDTH	C. COOKTOP WIDTH	D. TOTAL DEPTH TO FRONT OF RANGE	E. CUTOUT WIDTH*** (Countertop and cabinet)	F. CUTOUT DEPTH	G. HEIGHT OF COUNTERTOP
35 5/8" (90.5 cm) - 36 5/8" (93 cm)	30" (76,2 cm)	31 1/2" (80 cm)	28 5/16" (71,9 cm)	30±1/16" (76,2±0,15 cm)	21 3/4" (55,2 cm) Min. 22 1/8" (56,2 cm) Max 24" (61 cm) Min. with backguard	36 5/8" (93 cm) Max. 35 5/8" (90.5 cm) Min.

# Section A - Installation Instructions 7

## NOTES:

- 1** Do not pinch the power supply cord between the range and the wall.
- 2** Do not seal the range to the side cabinets.  
24" (61 cm) minimum clearance between the cooktop and the bottom of the cabinet when the bottom of wood or metal cabinet is protected by not less than 1/4" (0.64 cm) flame retardant millboard covered with not less than No. 28 MSG sheet metal, 0.015" (0.4 mm) stainless steel, 0.024" (0.6 mm) aluminum, or 0.020" (0.5 mm) copper.
- 3** 30" (76.2 cm) minimum clearance when the cabinet is unprotected.
- 4** For cutouts below 22 7/8" (58.1 cm), appliance will slightly show out of the cabinet.
- 5** Allow at least 19 1/4" (48.9 cm) clearance for door depth when it is open.

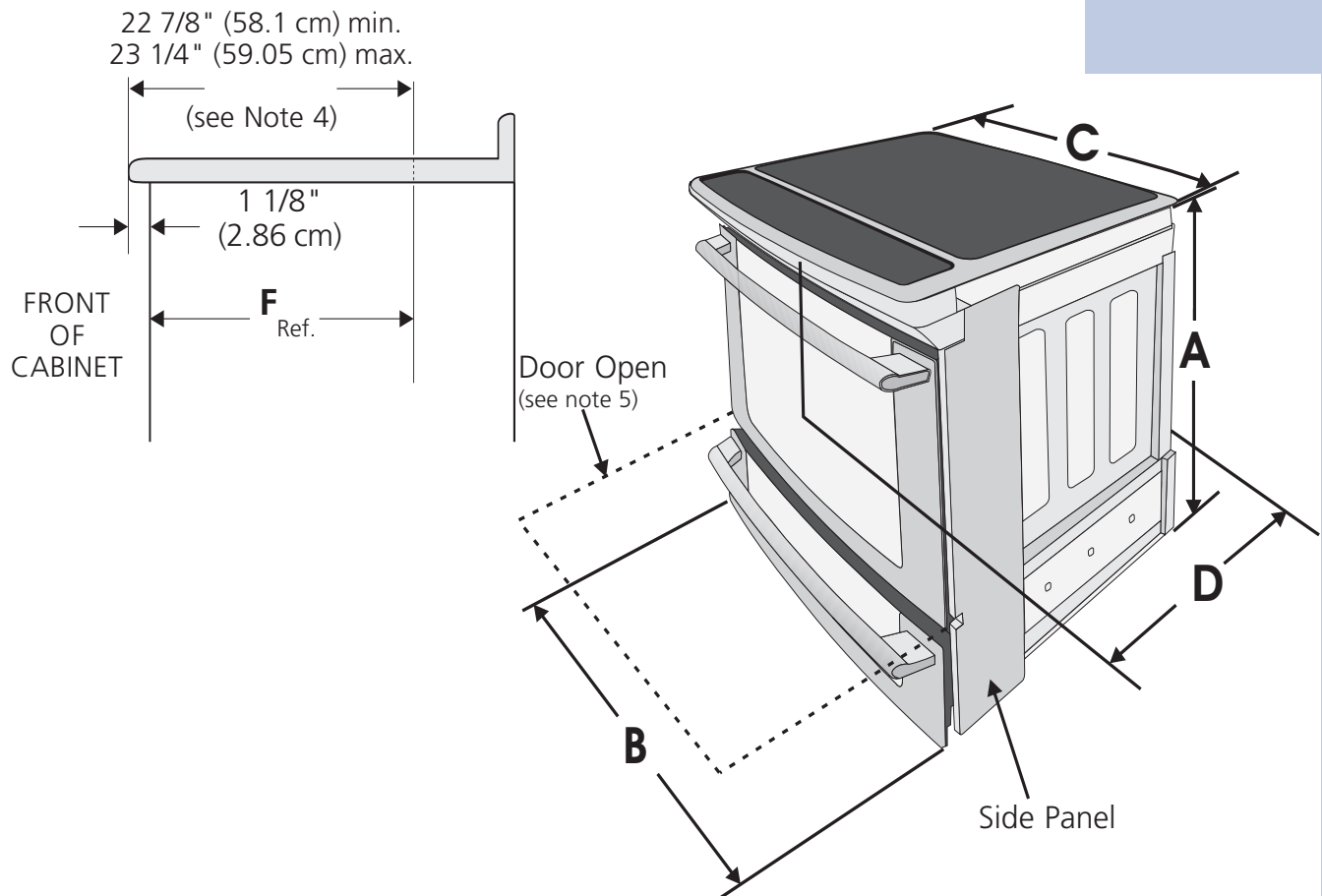

A. HEIGHT (Under Cooktop)	B. WIDTH	C. COOKTOP WIDTH	D. TOTAL DEPTH TO FRONT OF RANGE	E. CUTOUT WIDTH*** (Countertop and cabinet)	F. CUTOUT DEPTH	G. HEIGHT OF COUNTERTOP
35 5/8" (90.5 cm) - 36 5/8" (93 cm)	30" (76,2 cm)	31 1/2" (80 cm)	28 5/16" (71,9 cm)	30±1/16" (76,2±0,15 cm)	21 3/4" (55,2 cm) Min. 22 1/8" (56,2 cm) Max 24" (61 cm) Min. with backguard	36 5/8" (93 cm) Max. 35 5/8" (90.5 cm) Min.

# 8 Section A - Installation Instructions

**To avoid breakage: Do NOT handle or manipulate the unit by the cooktop glass.**

**1** The counter-top around the cut-out should be flat and leveled (see hatched area on illustration 1).

**2** Before installing the unit, measure the heights of the two (2) cabinet sides (H1-4), front and back (see illustration 1) from the floor to the top of the counter.

**3** Level the range using the four (4) leveling legs so that the height from the floor to the underside of the metal flange is greater than the tallest cabinet measurement by at least 1/16" (see illustration 2).

Shave Raised Edge to Clear Space for a 31½" (81 cm) Wide Cooktop.

1 ½" Max. (3.8 cm Max.)

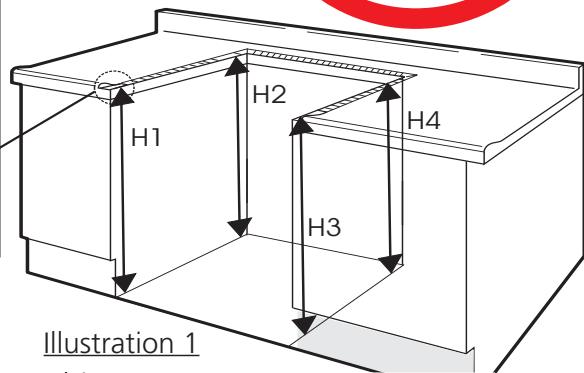
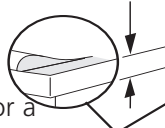
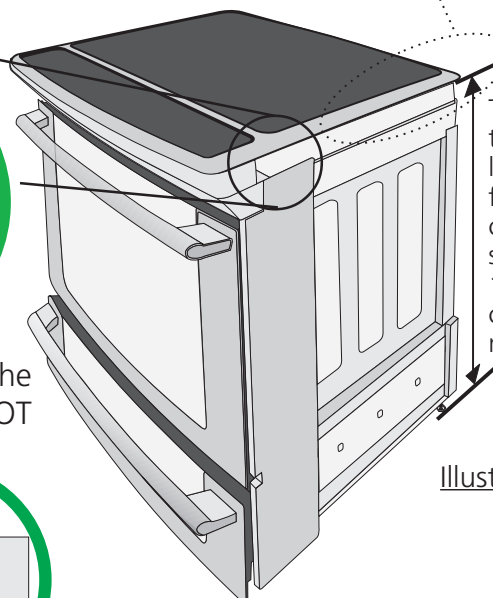
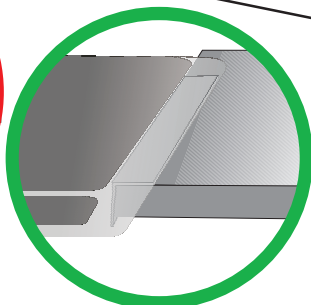
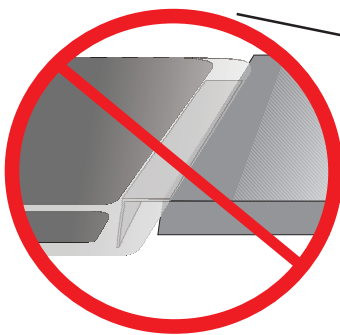
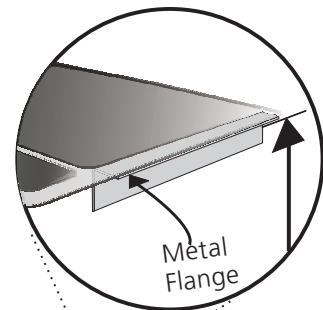

Illustration 1

**4** Slide the unit into the cabinet. Make sure the center of the unit is aligned with the center of the cabinet cut-out.

**5** Remove the protective channels on each side of the glass cooktop (if provided).

**6** The metal flange under each side of the cooktop **MUST** be placed over the cabinet countertop for proper unit support. The cooktop should **NOT** directly touch the countertop (see illustration 2) or could cause glass breakage voiding the warranty. Level the unit if needed.



To successfully install the range, the initial level height from floor to underside of cooktop frame should be at least 1/16" taller than cabinet sides as measured in step 1.

Illustration 2

**7** After the installation, MAKE SURE that the unit is supported by the leveling legs NOT by the cooktop.

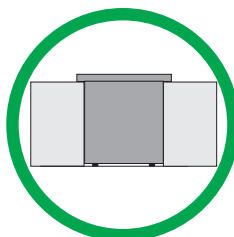
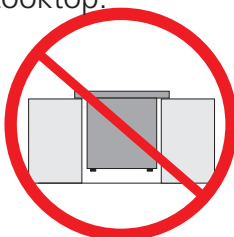

## Important Notes to the Installer

1. Read all instructions contained in these installation instructions before installing range.
2. Remove all packing material from the oven compartments before connecting the electrical supply to the range.
3. Observe all governing codes and ordinances.
4. Be sure to leave these instructions with the consumer.

## Important Note to the Consumer

Keep these instructions with your owner's guide for future reference.

# IMPORTANT SAFETY INSTRUCTIONS

**⚠ CAUTION** Cold temperatures can damage the electronic control. When using the appliance for the first time, or when the appliance has not been used for an extended period of time, be certain the unit has been in temperatures above 32°F (0°C) for at least 3 hours before turning on the power to the appliance.

- **Be sure your range is installed and grounded properly by a qualified installer or service technician.**
- **This range must be electrically grounded in accordance with local codes or, in their absence, with the National Electrical Code ANSI/NFPA No. 70—latest edition in United States or with CSA Standard C22.1, Canadian Electrical Code, Part 1 in Canada.**
- The installation of appliances designed for manufactured (mobile) home installation must conform with Manufactured Home Construction and Safety Standard, title 24CFR, part 3280 [Formerly the Federal Standard for Mobile Home Construction and Safety, title 24, HUD (part 280)] or when such standard is not applicable, the Standard for Manufactured Home Installation 1982 (Manufactured Home Sites, Communities and Setups), ANSI Z225.1/NFPA 501A—latest edition, or with local codes in United States and with CAN/CSA-Z240 MH in Canada.

- **Make sure the wall coverings around the range can withstand the heat generated by the range.**
- **Before installing the range in an area covered with linoleum or any other synthetic floor covering, make sure the floor covering can withstand heat at least 90°F (32.2°C) above room temperature without shrinking, warping or discoloring.** Do not install the range over carpeting unless you place an insulating pad or sheet of ¼" (0.64 cm) thick plywood between the range and carpeting.

**⚠ WARNING** Never leave children alone or unattended in the area where an appliance is in use. As children grow, teach them the proper, safe use of all appliances. Never leave the oven door open when the range is unattended.

**⚠ WARNING** Stepping, leaning or sitting on the door or drawer of this range can result in serious injuries and can also cause damage to the range.

- **Do not store items of interest to children in the cabinets above the range.** Children could be seriously burned climbing on the range to reach items.
- **To eliminate the risk of burns or fire by reaching over heated surface units, cabinet storage space above the surface unit should be avoided.** If cabinet storage is to be provided the risk can be reduced by installing a range hood that projects horizontally a minimum of 5 inches beyond the bottom of the cabinet.
- **Do not use the oven as a storage space.** This creates a potentially hazardous situation.
- **Never use your range for warming or heating the room.** Prolonged use of the range without adequate ventilation can be dangerous.
- **Do not store or use gasoline or other flammable vapors and liquids near this or any other appliance.** Explosions or fires could result.
- **Reset all controls to the "off" position after using a programmable timing operation.**



**⚠ WARNING**

- **All ranges can tip.**
- **Injury to persons could result.**
- **Install anti-tip device packed with range.**

To reduce the risk of tipping of the range, the range must be secured by properly installed anti-tip bracket(s) provided with the range. To check if the bracket(s) is installed properly, grasp the top rear edge of the range and carefully tilt it forward to make sure the range is anchored.

## FOR MODELS WITH SELF-CLEAN FEATURE:

- **Remove oven racks, broiler pan, food and other utensils before self-cleaning the oven.** Wipe up excess spillage. Follow the precleaning instructions in the Owner's Guide.

# 10 Section A - Installation Instructions

## 1. Power Supply Cord Kit (U.S.A.)

The user is responsible for connecting the power supply cord to the connection block located behind the back panel access cover.

This appliance may be connected by means of permanent "hard wiring"; flexible armored or nonmetallic shielded copper cable (when local code allow it) or by means of a power supply cord kit. See chart (on next page) for the minimum wire size (general UL listing, local code may differ).

Appliance Rating Watts	Minimum Conductor Size, AWG		
	L1 and L2 Conductors	Neutral Conductor	Ground Conductor
<b>120V / 208V</b>			
0 - 3120	16	16	14
3121 - 3900	16	16	12
3901 - 4160	14	16	12
4161 - 5200	14	16	10
5201 - 5570	12	16	10
5571 - 7430	12	14	10
7431 - 7800	12	12	10
7801 - 12500	10	12	10
12501 - 14500	8	12	10

Appliance Rating Watts	Minimum Conductor Size, AWG		
	L1 and L2 Conductors	Neutral Conductor	Ground Conductor
<b>120V / 240V</b>			
0 - 3600	16	16	14
3601 - 4500	16	16	12
4501 - 4800	14	16	12
4801 - 6000	14	16	10
6001 - 6425	12	16	10
6426 - 8749	12	12	10
8750 - 14500	10	12	10
14501 - 16500	10	10	10
16501 - 24000	8	10	8

**NOTE:** Electric Slide-in Range is shipped from factory with 1 1/8" (2.9 cm) dia. hole as shown on figure 4. If a larger hole is required, punch out the knockout.

**⚠ WARNING** Risk of fire or electrical shock exists if an incorrect size range cord kit is used, the Installation Instructions are not followed, or the strain relief bracket is discarded.

For mobile homes, new installations or recreational vehicles, use only a power supply kit designed for a range at 125V/250V 50A. Cord must have either 3 (when local code permits grounding through neutral) or 4 conductors. Terminal on end of wires must be either closed loop or open spade lug with upturned ends. Cord must have strain-relief clamp. See chart for the minimum wire size (general UL listing, local code may differ).

**⚠ CAUTION** Do not loosen the nuts which secure the factory-installed range wiring to terminal block while connecting range. Electrical failure or loss of electrical connection may occur.

## 2. Factory Connected Power Supply Cord (Canada only)

This range is equipped with a factory-connected power cord (see Figure 2). Cord must be connected to a grounded 120/240 volt or 120/208 volt range outlet with a 50A recommended circuit. If no outlet is available, have one installed by a qualified

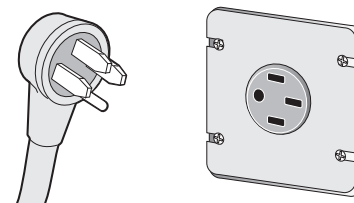

Canada Style  
Figure 2

### ⚠ WARNING

#### Electrical Shock Hazard

- Electrical ground is required on this appliance.
- Do not connect to the electrical supply until appliance is permanently grounded.
- Disconnect power to the circuit breaker or fuse box before making the electrical connection.
- This appliance must be connected to a grounded, metallic, permanent wiring system, or a grounding connector should be connected to the grounding terminal or wire lead on the appliance.

Failure to do any of the above could result in a fire, personal injury or electrical shock.

#### Serial Plate Location

You will find the model and serial number printed on the serial plate. The serial plate is located as shown.

Remember to record the serial number for future reference.

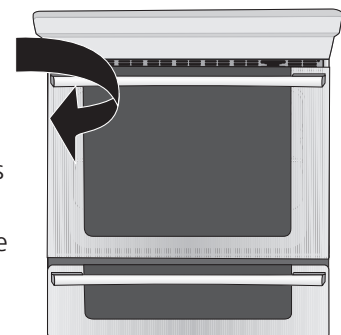

## 3. Electrical Connection to the Range (U.S.A.)

This appliance is manufactured with the neutral terminal connected to the frame.

### Three Conductor Wire Connection to Range

If local codes permit connection of the frame grounding conductor to the neutral wire of the copper power supply cord (see Figure 4):

1. Remove the 3 screws at the lower end of the rear wire cover, then bend the lower end of the rear wire cover (access cover) upward to expose range terminal connection block (see Figure 3).

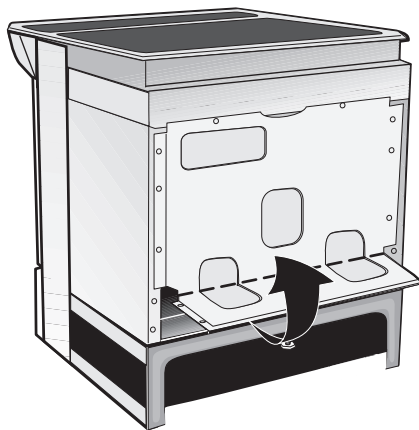

BEND REAR WIRE COVER HERE FOR ACCESS TO TERMINAL BLOCK

Figure 3

2. Remove the 3 loose nuts (after you remove the rubber band) on the terminal block using 3/8" nut driver or socket.
3. Connect the neutral of the copper power supply cord to the center silver-colored terminal of the terminal block, and connect the other wires to the outer terminals. Match wires and terminals by color (red wires connected to the right terminal, black wires connected to the left terminal).
4. Replace the 3 nuts on the terminal block (see figure 4).
5. Lower the terminal cover and replace the 3 screws.

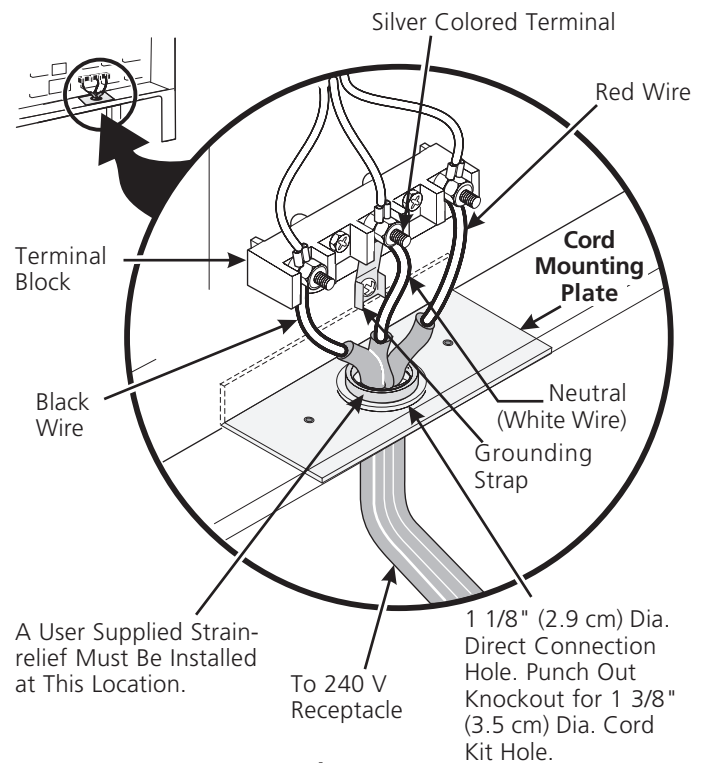

Figure 4

# 12 Section A - Installation Instructions

## Four Conductor Wire Connection to Range (mobile homes)

1. Remove the 3 screws at the lower end of the rear wire cover, then raise the lower end of the rear wire cover (access cover) upward to expose range terminal connection block (see figure 3).
2. Remove the 3 loose nuts (after you remove the rubber band) on the terminal block using a 3/8" (0,95 cm) nut driver or socket.
3. Remove the ground strap from the terminal block and from the appliance frame.
4. Connect the ground wire (green) of the copper power supply cord to the frame of the appliance with the ground screw, using the hole in the frame where the ground strap was removed (see Figure 5).
5. Connect the neutral of the copper power supply cord to the center silver-colored terminal of the terminal block, and connect the other wires to the outer terminals. Match wires and terminals by color (red wires connected to the right terminal, black wires connected to the left terminal).
6. Replace the 3 nuts on the terminal block (see figure 5).
7. Lower the terminal cover and replace the 3 screws.

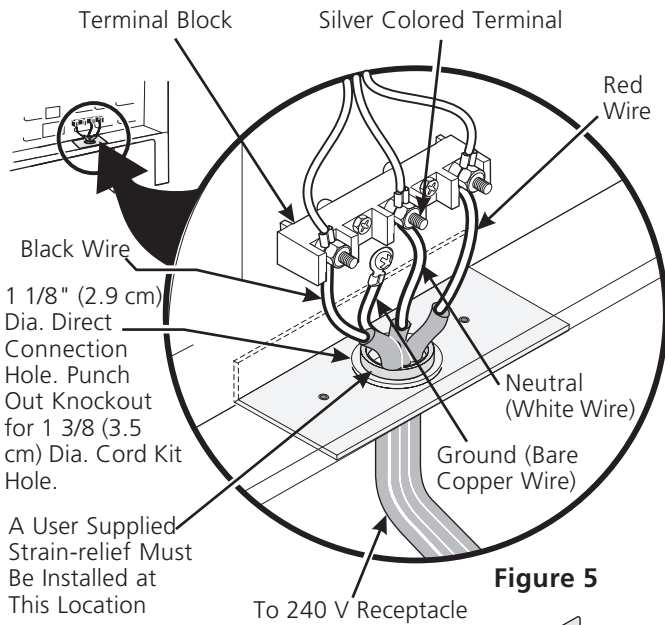
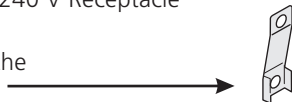

Figure 5

**NOTE:** Be sure to remove the supplied grounding strap.



## Direct Electrical Connection to the Circuit Breaker, Fuse Box or Junction Box

If the appliance is connected directly to the circuit breaker, fuse box or junction box, use flexible, armored or nonmetallic sheathed copper cable (with grounding wire). Supply a U.L. listed strain-relief at each end of the cable. At the appliance end, the cable goes through the Direct Connection Hole (see Figure 5) on the Cord Mounting Plate. Wire sizes (**copper wire only**) and connections must conform to the rating of the appliance.

### Where local codes permit connecting the appliance-grounding conductor to the neutral (white) wire (see Figure 6):

1. Disconnect the power supply.
2. In the circuit breaker, fuse box or junction box:
  - a) Connect the green (or bare copper) wire, the white appliance cable wire, and the neutral (white) wire together.
  - b) Connect the 2 black wires together.
  - c) Connect the 2 red wires together.

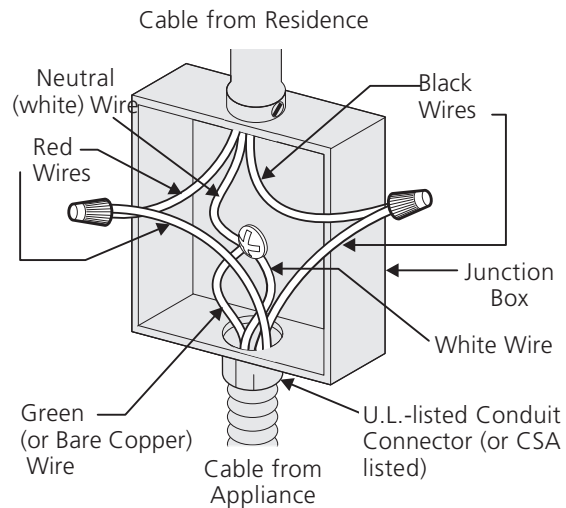
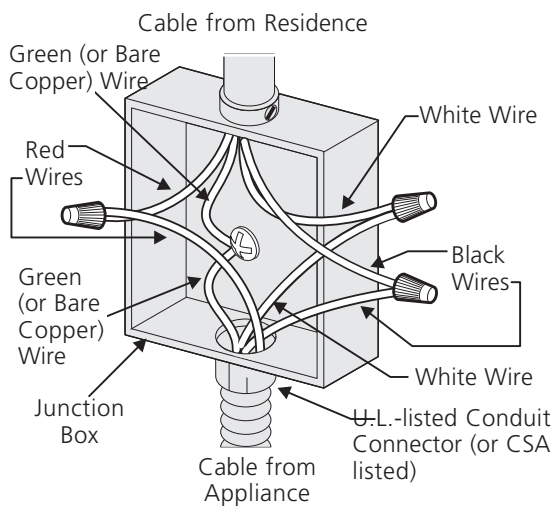

Figure 6  
3-Wire (Grounded Neutral) Electrical System  
(Example: Junction Box)



Where local codes DO NOT permit connecting the appliance-grounding conductor to the neutral (white) wire, or if connecting to 4-wire electrical system (see Figure 7):

1. Disconnect the power supply.
2. Separate the green (or bare copper) and white appliance cable wires.
3. In the circuit breaker, fuse box or junction box:
  - a) Connect the white appliance cable wire to the neutral (white) wire.
  - b) Connect the 2 black wires together.
  - c) Connect the 2 red wires together.
  - d) Connect the green (or bare copper) grounding wire to the grounding wire of the circuit breaker, fuse box or junction box.



**Figure 7 – 4-Wire Electrical System (Example: Junction Box)**

## 4. Cabinet Construction

- 4.1** **CAUTION** To eliminate the risk of burns or fire by reaching over heated surface units, do not have cabinet storage space above the range. If there is cabinet storage space above range, reduce risk by installing a range hood that projects horizontally a minimum of 5" (12.7 cm) beyond the bottom of the cabinet.

## 4.2 Countertop Preparation

- The cooktop sides of the range fit over the cutout edge of your countertop.
- If you have a **square finish (flat) countertop**, no countertop preparation is required. Cooktop sides lay directly on edge of countertop.
- **Formed front-edged countertops** must have molded edge shaved flat  $\frac{3}{4}$ " (1.9 cm) from each front corner of opening (Figure 8).
- **Tile countertops** may need trim cut back  $\frac{3}{4}$ " (1.9 cm) from each front corner and/or rounded edge flattened (Figure 8).

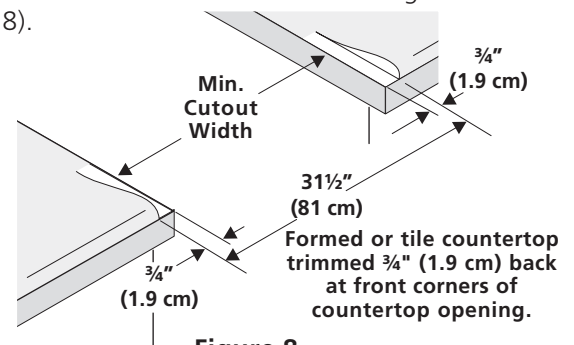

**Figure 8**

- If the existing cutout width is greater than **30 1/16" (76,4 cm)**, reduce the  $\frac{3}{4}$ " (1.9 cm) dimension.
- **Countertop must be level.** Place a level on the countertop, first side to side, then front to back. If the countertop is not level, the range will not be level. The oven must be level for satisfactory baking results. Cooktop sides of range fit over edges of countertop opening

**4.3** **IMPORTANT** For existing cutout width of **29" (73.7 cm)** (Figure 9):

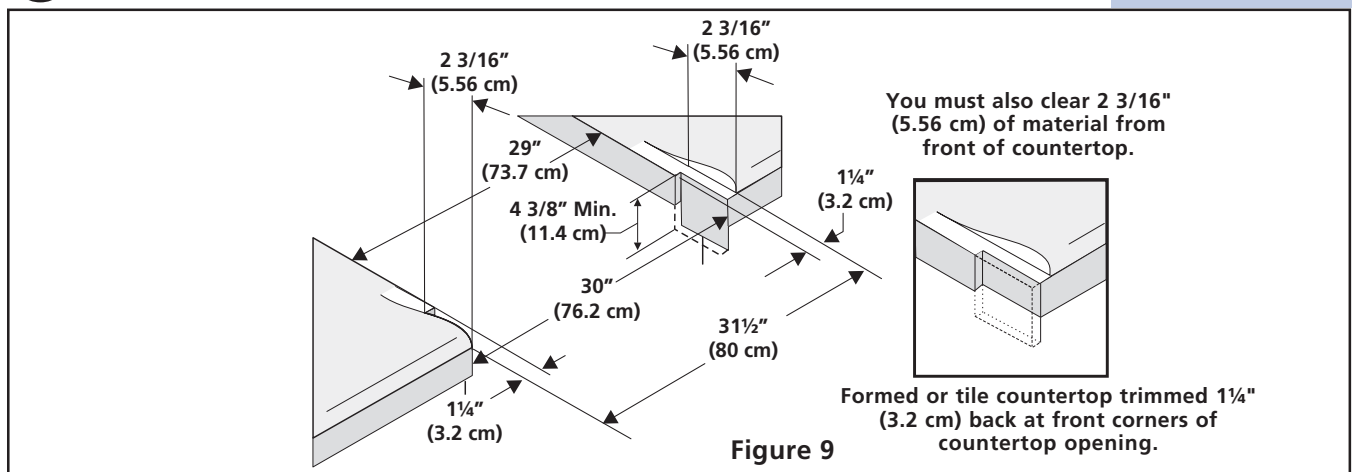
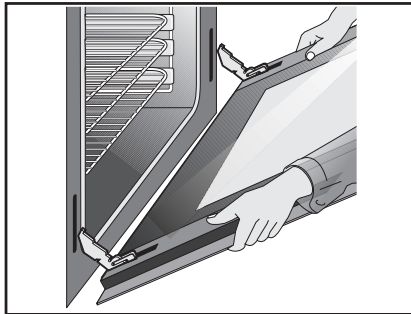

**Figure 9**

# 14 Section A - Installation Instructions

## 5. Range Installation

**Important Note:** Door removal is not a requirement for installation of the range, but is an added convenience. Refer to the Use and Care Guide for oven door removal instructions.



### Standard Installation

- 1 The range cooktop overlaps the countertop at the sides and the range rests on the floor. The cooktop is 31½" (80 cm) wide.
- 2 Install base cabinets 30" (76.2 cm) apart. Make sure they are plumb and level before attaching cooktop. Shave raised countertop edge to clear 31½" (80 cm) wide range top rim.
- 3 Install cabinet doors 32" (81.3 cm) min. apart so as not to interfere with range door opening.
- 4 Cutout countertop exactly as shown on page 1.
- 5 Make sure the four leveling legs (front and rear) are setup higher than the height of the cabinet (shown on page 3).

- CAUTION** Install the anti-tip bracket at this point before placing the range at its final position. Follow the installation instructions on page 11 or on the anti-tip bracket template supplied with the range.

- 7 To provide an optimum installation, the top surface of the countertop must be level and flat (lie on the same plane) around the 3 sides that are adjacent to range cooktop. Proper adjustments to make the top flat should be made or gaps between the countertop and the range cooktop may occur.

- 8 **CAUTION** To reduce the risk of damaging your appliance, do not handle or manipulate it by the ceramic glass. Manipulate with care.

- 9 Position range in front of the cabinet opening.
- 10 Make sure that the glass which overhangs the countertop clears the countertop. If necessary, raise the unit by lowering the leveling legs.
- 11 **Level the range** (see section 6). The floor where the range is to be installed must be level. Follow the instructions under "Leveling the Range".
- 12 Slide the range into the cutout opening.

### **IMPORTANT** If Accessories Needed :

#### Installation For 29" Existing Cutout Wide Opening

1. You must replace the actual side trims by new and smaller side trims. These new side trims can be ordered through a Service Center.
2. Follow instructions supplied with your new side trims to replace the actual side trims with the new ones.
3. Check if the countertop and cabinet opening are prepared for 29" cutout wide opening in "**Countertop Preparation**" section (see page 8).
4. Install range as in the "**Installation without side panels**" section.

#### Installation With Backguard

The cutout depth of (21 3/4" (55.2 cm) Min., 22 1/8" (56.2cm) Max.) needs to be increased to 24" (61 cm) when installing a backguard.

#### Installation With End Panel

A End Panel kit can be ordered through a Service Center.

#### Installation With Side Panels

A Side Panels kit can be ordered through a Service Center.

Install cabinet doors 32" (81.3 cm) min. apart so as not to interfere with range door opening.

## 6. Leveling the Range

**Models Equipped with Leveling Device**  
Level the range after installation in the cutout opening.

1. Open the range drawer. The leveling screws control the height of the rear leg.
2. Adjust the appliance legs as follows until the underside of the cooktop surface is sitting level on the countertop (Figure 10).
  - a. To adjust the front legs, use a wrench on the leg base and turn clockwise to lower or counterclockwise to raise.
  - b. To adjust the rear legs, use a ratchet or a nutdriver and turn the leveling screws counterclockwise to lower or clockwise to raise.
3. Check if the range is level by installing an oven rack in the center of the oven and placing a level on the rack (Figure 11).
4. Take 2 readings with the level placed diagonally in one direction and then the other. Level the range, if necessary, by adjusting the leveling legs.
5. If the range cannot be level, contact a carpenter to correct sagging or sloping floor.

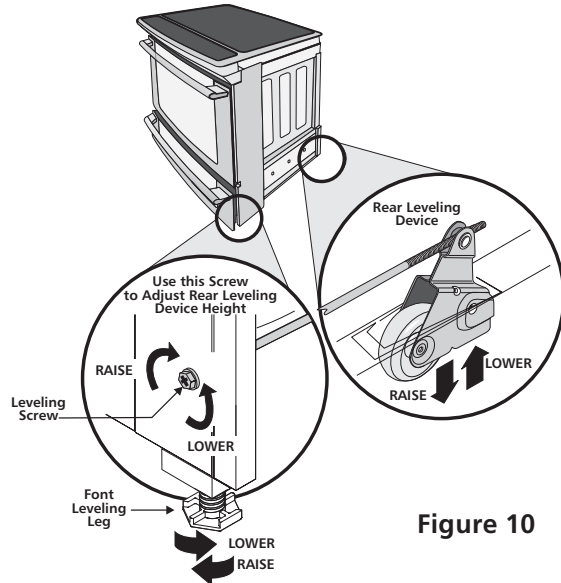

Figure 10

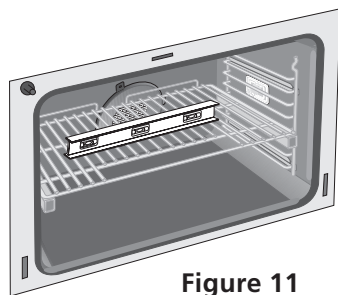

Figure 11

## 7. Check Operation

Refer to the Use and Care Manual packaged with the range for operating instructions and for care and cleaning of your range.

**CAUTION** Do not touch the elements. They may be hot enough to cause burns.

Remove all packaging from the oven before testing.

### 1. Operation of Surface Elements

Turn on each of the four surface elements and check to see that they heat. Check the surface element indicator light(s), if equipped.

### 2. Operation of Oven Elements

The oven is equipped with an electronic oven control. Each of the functions has been factory checked before shipping. However, it is suggested that you verify the operation of the electronic oven controls once more. Refer to the Use and Care Manual for operation. Follow the instructions for the Clock, Timer, Bake, Broil, Convection (some models) and Clean functions.

**Bake**—After setting the oven to 350°F (177°C) for baking, the lower element in the oven should become red.

**Broil**—When the oven is set to BROIL, the upper element in the oven should become red.

**Clean**—When the oven is set for a self-cleaning cycle, the upper element should become red during the preheat portion of the cycle.

**Convection (some models)**—When the oven is set to CONV. BAKE/ROAST at 350°F (177°C), both elements cycle on and off alternately and the convection fan will turn. The convection fan will stop turning when the oven door is opened during convection baking or roasting.

**Warmer Drawer (some models)**—Set the control knob to HI and check to see the drawer is heating.

### When All Hookups are Complete

Make sure all controls are left in the OFF position.

### Model and Serial Number Location

The serial plate is located on the oven front frame behind the oven door (some models) or behind the drawer (some models).

When ordering parts for or making inquiries about your range, always be sure to include the model and serial numbers and a lot number or letter from the serial plate on your range.

### Before You Call for Service

Read the Before you call list and operating instructions in your Use and Care Manual . It may save you time and expense. The list includes common occurrences that are not the result of defective workmanship or materials in this appliance.

Refer to the warranty and service information in your Use and Care Manual for our phone number and address. Please call or write if you have inquiries about your range product and/or need to order parts.

# 16 Section A - Installation Instructions

## 8. Anti-Tip Brackets Installation Instructions

**⚠ WARNING** To reduce the risk of tipping of the range, the range must be secured to the floor by properly installed anti-tip bracket and screws packed with the range. These parts are located in the oven. Failure to install the anti-tip bracket will allow the range to tip over if excessive weight is placed on an open door or if a child climbs upon it. Serious injury might result from spilled hot liquids or from the range itself.

Follow the instructions below to install the anti-tip brackets.

If range is ever moved to a different location, the anti-tip brackets must also be moved and installed with the range.

### Tools Required:

Adjustable Wrench  
Ratchet  
Drill & 1/8" (0,32 cm) bit  
5/16" (0,8 cm) Nutdriver  
Level

The anti-tip bracket attaches to the floor at the back of the range to prevent range from tipping. When fastening bracket to the floor, be sure that screws do not penetrate electrical wiring or plumbing. The screws provided will work in either wood or concrete.

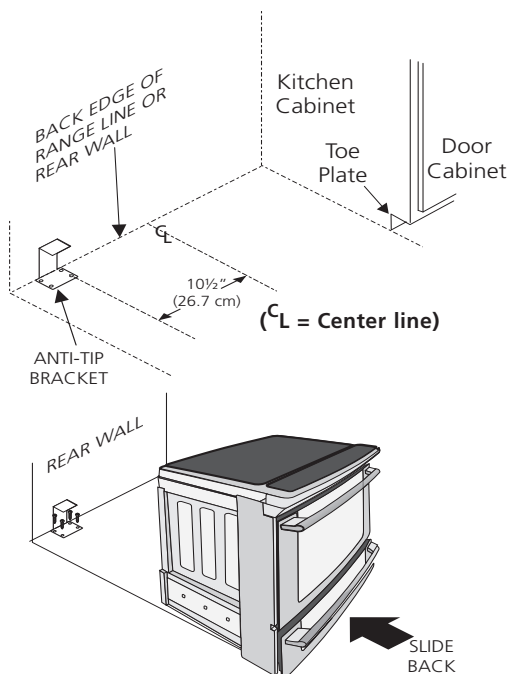

Figure 12

1. Draw a center line (CL) on the floor where the range should be installed. Also draw a line on the floor at the range back position if there is no wall.
2. Unfold paper template and place it flat on the floor with the right rear corner positioned exactly on the intersection of the center and back lines you just drew before. (Use the diagram below to locate brackets if template is not available. (Figure 12))
3. Mark on the floor the location of the 4 mounting holes shown on the template. For easier installation, 3/16" (0,48 cm) diameter pilot holes 1/2" (1,27 cm) deep can be drilled into the floor.
4. Remove template and place bracket on floor. Line up holes in bracket with marks on floor and attach with 4 screws provided. Bracket must be secured to solid floor (Figure 13). If attaching to concrete floor, first drill 3/16" (0,48 cm) dia. pilot holes using masonry drill bit.
5. Be sure the 4 levelling legs are at the highest position they can be.
6. Slide range into place making sure structure of the range is trapped by the anti-tip bracket (Figure 12). Lower the range by adjusting the 4 levelling legs until the underside of the cooktop is sitting level on the countertop. Refer to "Levelling the Range" section.
7. After installation, verify that the anti-tip bracket is engaged by grasping the top rear edge of the range and carefully attempt to tilt it forward to make sure range is properly anchored.

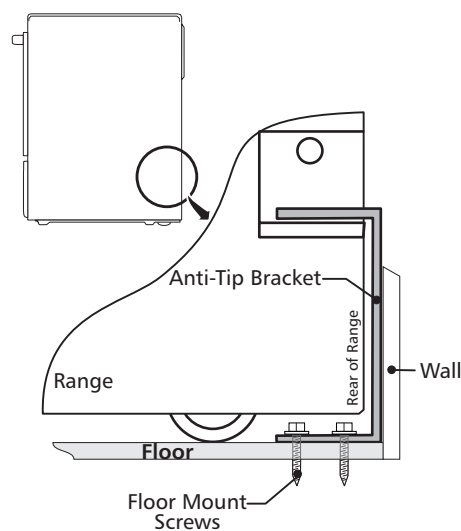
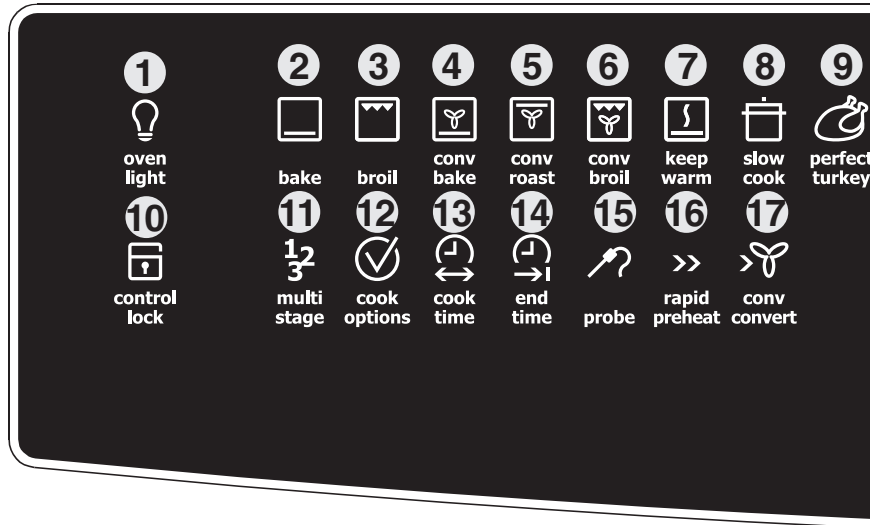

Figure 13

## OVEN CONTROL PAD FUNCTIONS



- 1 Light Pad-** Used to turn the oven light on and off.
- 2 Bake Pad-** Used to enter the normal baking mode temperature.
- 3 Broil Pad-** Used to select the variable broil mode.
- 4 Convection Bake Pad-** Used to select the convection baking mode.
- 5 Convection Roast Pad-** Used to select the convection roasting mode.
- 6 Convection Broil Pad-** Used to select the convection broil mode.
- 7 Keep Warm Pad-** Used to select the keep warm mode.
- 8 Slow Cook Pad-** Used to select the slow cook mode.
- 9 Perfect Turkey Pad-** Used to select the perfect turkey cooking mode.
- 10 Control Lock Pad-** Used to disable all oven function.
- 11 Multi Stage Pad-** Used to enter up to three subsequent modes.
- 12 Cook Options Pad-** Used to light up the cooking options pads.
- 13 Cook Time Pad-** Used to set a cooking duration time.
- 14 End Time Pad-** Used to select the time at which the cooking will end.
- 15 Probe Pad-** Used to activate the meat probe mode.
- 16 Rapid Preheat Pad-** Used to preheat the oven to the desired temperature.
- 17 Conv. Convert Pad-** Used to convert a standard temperature to a convection temperature.

# 18 Section B - Electronic Controls

## COOKTOP CONTROL PAD FUNCTIONS

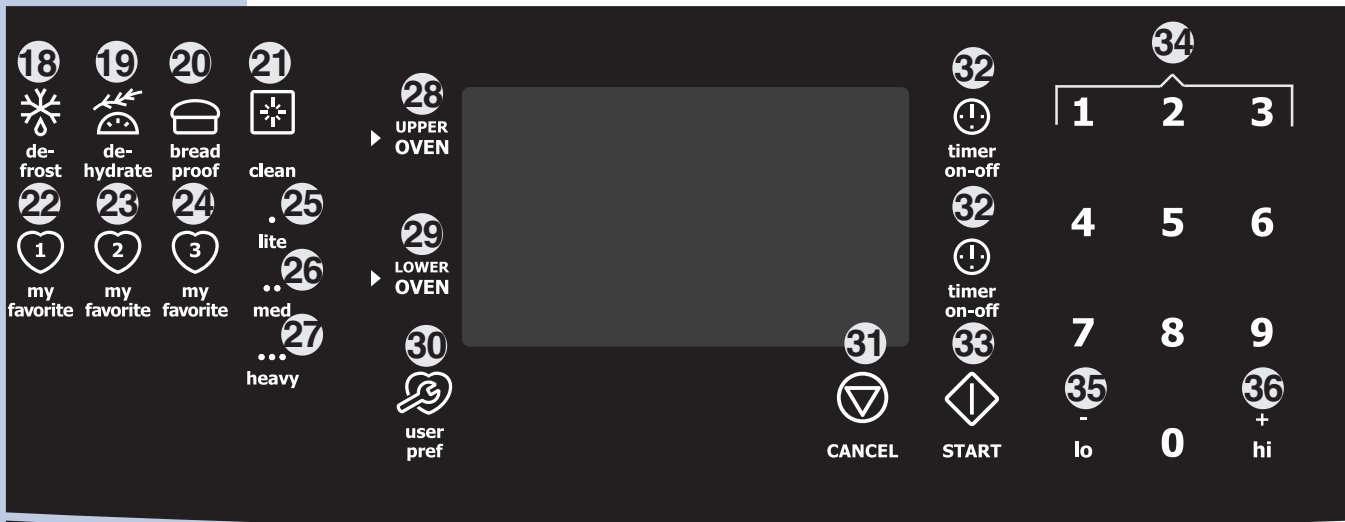

- 18 Defrost Pad**- Used to select the defrost mode.
- 19 Dehydrate Pad**- Used to select the dehydrate mode.
- 20 Bread Proof Pad**- Used to select the bread proof mode.
- 21 Clean Pad**- Used to select the self-cleaning mode.
- 22 My Favorite 1 Pad**- Used to save or recall the favorite 1 cooking mode.
- 23 My Favorite 2 Pad**- Used to save or recall the favorite 2 cooking mode.
- 24 My Favorite 3 Pad**- Used to save or recall the favorite 3 cooking mode.
- 25 Lite Pad**- Used to start a 2 hours self-clean cycle.
- 26 Med Pad**- Used to start a 3 hours self-clean cycle.
- 27 Heavy Pad**- Used to start a 4 hours self-clean cycle.
- 28 Upper Oven Pad**- Used to activate the upper oven for cooking operation.
- 29 Lower Oven Pad**- Used to activate the lower oven for cooking operation.
- 30 User Preference Pad**- Used to bring the user preference menu in the display.
- 31 Cancel Pad**- Used to cancel any function previously entered except the time of day and minute timer. Push **Cancel pad** to stop cooking.
- 32 Timer Pads**- Used to set or cancel the minute timer. The minute timer does not start or stop cooking.
- 33 Start Pad**- Used to start all oven functions.
- 34 0 Through 9 Number Pads**- Used to enter temperature and times.
- 35 - lo Pad**- Used to lower the temperature and times.
- 36 + hi Pad**- Used to raise the temperature and times.

## COOKTOP CONTROL PAD FUNCTIONS

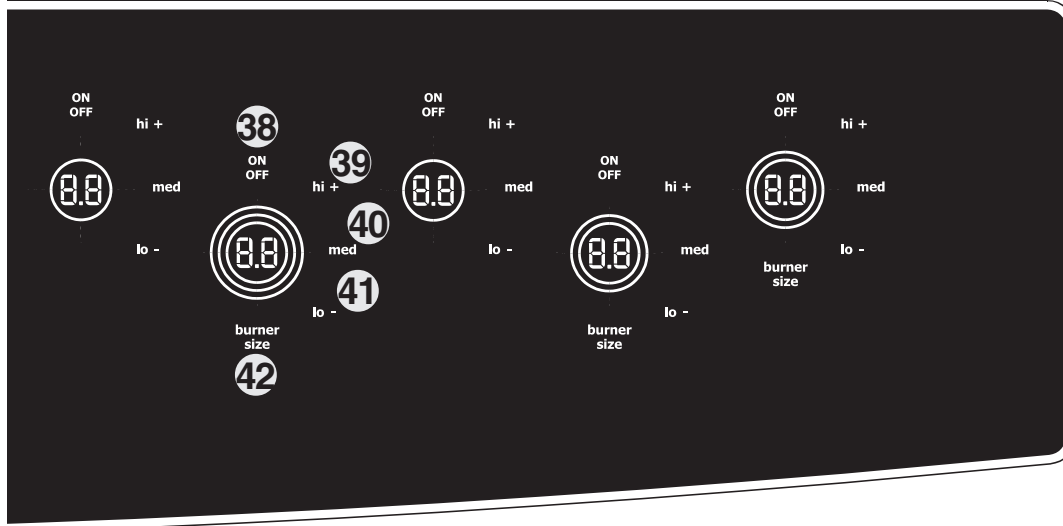



- 38 ON / OFF Pad-** Used to toggle ON and OFF the associated surface element.
- 39 HI + Pad-** Used to select the highest element temperature or raise the temperature currently displayed.
- 40 MED Pad-** Used to select the medium element temperature.
- 41 LO - -** Used to select the lower element temperature or lower the temperature currently displayed.
- 42 Burner Size Pad-** Used to toggle between the available surface element burner sizes.

## SETTING CLOCK AT POWER UP

When the unit is first plugged in, or when the power supply to the range has been interrupted, the timer in the display will flash with "12:00". The clock cannot be set when the oven is on. If an invalid time of day is entered, the control will triple beep to prompt you to re-enter a valid time of day.

### To set the clock (example for 1:30):

1. Press **1** **3** **0** pads to set the time of day to 1:30. The pads  $^{+}$ <sub>hi</sub> or  $^{-}$ <sub>lo</sub> can also be pressed to raise or lower the actual time displayed.
2. Press **START**  to accept the changes or **CANCEL**  to start with a time of 12:00.

## CONTROL PANEL DISPLAY MODES

### Sleep Mode:

Your control will remain in a sleep mode when not in use. Only the clock will display during this mode. You will need to wake the control to begin any function.



### Wake Mode:

To wake the control, touch within the display panel. After 2 minutes without activity the control will beep and go back into sleep mode.

To start a cooking feature you must select either the upper oven or the lower oven. User preferences will be available during this mode as well as timers, oven light and the control lock.

## TEMPERATURE VISUAL DISPLAY

Your oven is equipped with a temperature visual display for each oven. When a cooking mode is set, the actual temperature will be shown in the display and will rise as the unit preheat. When the unit has reached its target temperature, a chime will sound to remind you to place the food in the oven. This feature will be active with some cooking modes; bake, convection bake, convection roast and perfect turkey. The cooking modes which does not feature the temperature visual display will be noted in their descriptions.

NOTE: The lowest temperature that can be displayed is 100°F.



## OVEN LIGHT

Your appliance includes “theater” style oven lighting feature that gradually lights both the upper and lower oven interiors to full brightness. The upper oven is equipped with 2 halogen lights and the lower oven is equipped with 1 incandescent light. The oven lights will turn on automatically when the oven door is opened. The oven light may be turned on when the door is closed by using the oven light pad located on the control panel. The oven light key will toggle the lights in both ovens at the same time at full intensity.

### To toggle the Oven Lights ON and OFF:

1. Press **OVEN LIGHT** .



## CONTROL LOCK

The Control Lock feature automatically locks the upper oven door, control panel and the cooktop. The Control Lock is only allowed when the oven and the cooktop are turned OFF (not active). DOOR LOCK will flash in the display for 20 seconds or until the door has finished locking. Once the door has been locked, **Loc** message will appear in the upper display and “- -” will appear in the cooktop displays. Do not attempt to open the oven door while DOOR LOCK is flashing.

### To toggle the Control Lock ON and OFF:





1. Keep **CONTROL LOCK**  pressed for 3 seconds.



## SETTING THE KITCHEN TIMER

This unit is equipped with 2 Kitchen Timers which serves as extra timers in the kitchen that will beep when the set time has run out. It does not start or stop cooking. The Timer feature can be used during any of the other oven control functions and cooking modes.

### To set the Timer (example for 5 minutes):

1. Press **TIMER** . “00:00” will appear in the display.
2. Press **5** pad to set the timer to 5 minutes. The pads  $_{hi}^{+}$  or  $_{lo}^{-}$  can also be pressed to raise or lower the actual time displayed.
3. Press again **TIMER**  to accept and start the countdown.
4. When the set time has run out, “00:00” will be displayed and the **TIMER**  pad will flash. The clock will sound a chime that will be repeated at regular intervals until the **TIMER**  pad is pressed.



### To cancel the Timer before the set time has run out:

Press **TIMER** . The display will return to the time of day.

## BAKING



This mode is best used for your standard recipes. The hidden bake element is used to heat the air and maintain temperature. The temperature probe can be used in this cooking mode. The upper oven can be programmed to bake at any temperature from 170°F to 550°F with a default temperature of 350°F. The lower oven can be programmed to bake at any temperature from 170°F to 450°F with a default temperature of 350°F.

### Upper Oven Baking Tips:

- Always preheat your oven before using the bake mode.
- During preheat, the 3 elements and the convection fan are used in cycle to quickly heat the oven.
- Use only one rack and center the pans as much as possible.
- If using two racks, place the oven racks in positions 2 and 6.
- Allow 2" to 4" (5,1 to 10,2 cm) around the utensil(s) for proper air circulation.
- Be sure the pans do not touch each other, the door, sides or back of the oven.

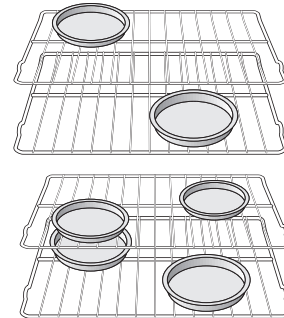

**If using multiple pans or racks, stagger as shown.**



### Lower Oven Baking Tips:

- Follow recommendations for lower oven cooking modes in the **Lower Oven Operation** section of this manual.

### To set a Bake Temperature of 350°F:

1. Arrange interior oven racks.
2. Select oven by pressing **UPPER OVEN** <sup>UPPER</sup> <sub>OVEN</sub> or **LOWER OVEN** <sup>LOWER</sup> <sub>OVEN</sub>.
3. Press **BAKE** .
4. Press **START** . The oven display shows **PRE-HEATING**.
5. Place food in the oven when the chime signals and temperature display shows that the oven has reached the set target temperature and the **PRE-HEATING** message disappear.
6. Cook Time, Timer and End Time features can be set to control your cooking time in both ovens (read their sections for directions). The Temperature Probe and Rapid Preheat features can be used only with the upper oven.
7. Remove food. Always use oven mitts when removing hot pans from the oven.
8. Press **CANCEL**  to stop or cancel the Bake feature at any time.

### To change to a Bake Temperature of 425°F:

1. Select oven by pressing **UPPER OVEN** <sup>UPPER</sup> <sub>OVEN</sub> or **LOWER OVEN** <sup>LOWER</sup> <sub>OVEN</sub>.
2. Press the **HI** <sup>+</sup> <sub>hi</sub> or **LO** <sup>-</sup> <sub>lo</sub> pads to get to the desired temperature.
3. Press **START** .

### Baking Problems





Refer to the Baking Problems Table in the Solutions to Common Problems section of this manual.

## COOK TIME

Cook Time allows the oven to be set to cook for a set length of time and shut off automatically. The time remaining will always be shown in the timer section of the display. The oven will shut off and will beep when the countdown is finished. This feature can be used with Bake, Convection Bake, Convection Roast, Slow Cook, Keep Warm, Defrost, Bread Proof, Dehydrate and Perfect Turkey cooking modes. It can also be part of a Multi-Stage sequence.



**To set a timed cooking** (example is a 450°F Bake for 30 minutes):







1. Select oven by pressing **UPPER OVEN** UPPER OVEN.
2. Press **BAKE** . The temperature numbers will blink in the display.
3. Enter temperature needed; **4 5 0**.
4. Press **COOK OPTIONS**  to bring up the cook options items.
5. Press **COOK TIME** .
6. Enter time needed; **3 0**.
7. Press **START** . The oven will start heating. The cook time will start counting down for the set time.
8. Press **CANCEL**  to stop the audible alarm or to cancel cooking at anytime.

## END TIME

End Time allows the oven to be set to shut off automatically at a set time of day. The oven control will calculate the remaining time by itself. The time remaining will always be shown in the timer section of the display. The oven will shut off and will beep when the countdown is finished. This feature can be used with Bake, Convection Bake, Convection Roast, Slow Cook, Keep Warm, Defrost, Dehydrate, Clean and Bread Proof cooking modes. This oven can be programmed with Cook Time and End Time to start and stop by itself at the right time.



**To set a delayed timed cooking** (example is a 450°F Bake for 30 minutes which will end at 6:00PM):

1. Select oven by pressing **UPPER OVEN** UPPER OVEN.
2. Press **BAKE** . The temperature numbers will blink in the display.
3. Enter temperature needed; **4 5 0**.
4. Press **COOK OPTIONS**  to bring up the cook options items.
5. Press **COOK TIME** .
6. Enter time needed; **3 0**. Press **END TIME** .
7. Enter time of day needed; **6 0 0**.
8. Press **START** . The time remaining will be shown in the display.
9. Press **CANCEL**  to stop the audible alarm or to cancel cooking at anytime.

**CAUTION** Use caution with the **COOK TIME** or **END TIME** features. Use the automatic timer when cooking cured or frozen meats and most fruits and vegetables. Foods that can easily spoil such as milk, eggs, fish, meat or poultry, should be chilled in the refrigerator first. Even when chilled, they should not stand in the oven for more than 1 hour before cooking begins, and should be removed promptly when cooking is completed. Eating spoiled food can result in sickness from food poisoning.

## BROILING







This mode is best for meats, fish and poultry up to 1" thick. Broiling is a method of cooking tender cuts of meat by direct heat under the broil element of the oven. The high heat cooks quickly and gives a rich, brown outer appearance. The temperature probe cannot be used with this mode. The oven can be programmed to broil at any temperature from 300°F to 550°F with a default temperature of 550°F.

### Broiling Tips:

- For optimum browning, preheat the broil element for 2 minutes.
- Broil one side until the food is browned; turn and cook on the second side. Season and serve.
- Always pull the rack out to the "stop" position before turning or removing food.
- Always use the broiler pan and its grid when broiling. It allows the dripping grease to be kept away from the high heat of the broil element (see Figure 1).
- For best broiling results, broil with the oven door slightly open.
- **DO NOT** use the broil pan without the insert. **DO NOT cover the broil pan insert with foil.** The exposed grease could catch fire. **DO NOT** use the roasting rack when broiling.

### To set a Broil Temperature of 550°F:

1. Arrange interior oven racks.
2. Select oven by pressing **UPPER OVEN** .
3. Press **BROIL** .
4. Press **START** .
5. Place food in the oven after 2 minutes.
6. Turn food when the top side is browned and cook on the second side.
7. Remove food. Always use oven mitts when removing hot pans from the oven.
8. Press **CANCEL**  to stop or cancel the Broil feature at any time.

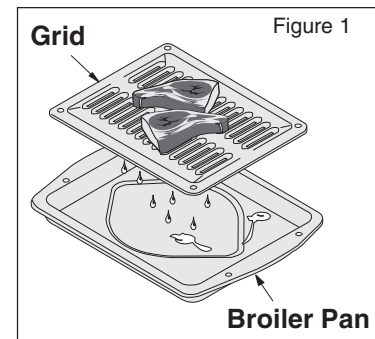

### Broiling Times

Electric Wall Oven Broiling Table Recommendations					
Food Item	Rack Position	Temp Setting	Cook Time		Doneness
			1st side	2nd side	
Steak 1" thick	7	550° F	6:00	4:00	Rare
	7	550° F	7:00	5:00	Medium
Pork Chops 3/4" thick	7	550° F	8:00	6:00	Well
Chicken - Bone In	5	450° F	20:00	10:00	Well
Chicken - Boneless	7	450° F	8:00	6:00	Well
Fish	7	500° F	13:00	0:00	Well
Shrimp	5	550° F	5:00	0:00	Well
Hamburger 1" thick	7	550° F	9:00	7:00	Medium
	5	550° F	10:00	8:00	Well

**WARNING** Should an oven fire occur, close the oven door and turn off the oven. If the fire continues, throw baking soda on the fire or use a fire extinguisher. **DO NOT** put water or flour on the fire. Flour may be explosive and water can cause a grease fire to spread and cause personal injury.

## CONVECTION BAKING

This mode of cooking enables you to obtain the best culinary results when baking with multiple pans and racks. Multiple rack baking may slightly increase cook time for some foods but the overall result is time saved. Most foods cooked in a standard oven will cook faster and more evenly with Convection Bake. Convection baking uses the three elements and a fan to circulate the oven's heat evenly and continuously within the oven. The temperature probe can be used in this cooking mode. The oven can be programmed for Convection baking at any temperature between 170°F to 550°F with a default temperature of 350°F.



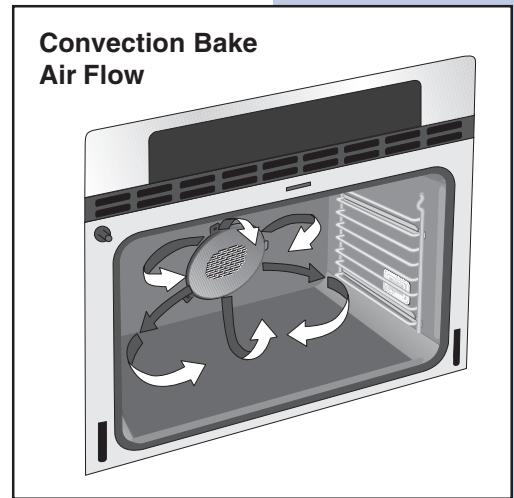

### Convection Baking Tips:

- Always preheat your oven before using the Convection Bake mode.
- If your recipe cooking temperature has already been converted for convection baking there is no need to reduce your oven temperature. If your recipe has not had the temperature converted for convection baking you can easily reduce the temperature using the Convection Convert feature. Please see Convection Convert section on next page for further instruction on temperature conversion.
- Use tested recipes with times adjusted for convection baking when using this mode. With single rack convection baking some foods may have as much as a 25% reduction in cook time; check food at minimum time. Time reductions will vary depending on the amount and type of food to be cooked.
- When using Convection Bake with a single rack, place oven rack in position 3 or 4. If cooking on multiple racks, place the oven racks in positions 2 and 6 or 1, 4 and 7.
- Most bakeries (except cakes) should be baked on pans with no sides or very low sides to allow heated air to circulate around the food.
- Food baked on pans with a dark finish will cook faster.



### To set a Convection Bake Temperature of 350°F:

1. Arrange interior oven racks.
2. Select oven by pressing **UPPER OVEN** UPPER OVEN.
3. Press **CONVECTION BAKE** .
4. Press **START** . The oven display shows **PRE-HEATING**.
5. Place food in the oven when the chime signals and temperature display shows that the oven has reached the set target temperature and the **PRE-HEATING** message disappear.
6. The Temperature Probe, Cook Time, Timer, End Time and Rapid Preheat features can be set to control your cooking time (read their sections for directions).
7. Remove food. Always use oven mitts when removing hot pans from the oven.
8. Press **CANCEL**  to stop or cancel the Convection Bake feature at any time.





## CONVECTION CONVERT



The Convection Convert pad is used to automatically convert a standard baking recipe for convection baking. When set properly, this feature is designed to display the actual converted (reduced) temperature in the display. Convection Convert may ONLY be used with a Convection Bake cooking mode. It can be used with the features End Time and Cook Time (see their sections for directions). If convection conversion is used with the cook time and end time features, “CF” (check food) will be displayed when 75% of the bake time is complete. At this time the oven control will sound 3 long beeps at regular intervals until baking had finished. When the bake time has completely finished the control will beep at regular interval until the **CANCEL**  pad is pressed.

**NOTE:** To use this feature with the **COOK TIME**  option, the **COOK TIME**  pad must be pressed before the **CONVECTION CONVERT**  pad.

### Changing from a normal bake temperature to a convection bake temperature:

1. Select oven by pressing **UPPER OVEN** .
2. Press **CONVECTION BAKE** .
3. Press **COOK OPTIONS** . The cook options items will light up.
4. Press **CONVECTION CONVERT** . The temperature displayed will be 25°F lower than what it used to be.
5. Press **START**  to begin the convection baking (see Convection Baking section for more informations).





## RAPID PREHEAT



The Preheat feature will bring the oven up to temperature faster than a regular preheat and then indicate when to place the food in the oven. Preheating is not necessary when roasting or cooking casseroles. The oven can be programmed to preheat at any temperature between 170°F to 550°F with some of the cooking modes; Bake, Convection Bake and Convection Roast.

**IMPORTANT:** The rapid preheat feature is for single rack ONLY. The heat distribution with multiple rack will be uneven.

### To set a rapid preheat (example is for a 350°F Bake):

1. Select oven by pressing **UPPER OVEN** .
2. Press **BAKE** .
3. Press **COOK OPTIONS** . The cook options items will light up.
4. Press **RAPID PREHEAT** .
5. Press **START**  to begin the baking with the rapid preheat feature enabled.
6. Place food in the oven when the chime signals and temperature display shows that the oven has reached the set target temperature.

## CONVECTION ROASTING



This mode is best for cooking tender cuts of beef, lamb, pork and poultry. Use this mode when cooking speed is desired. The Convection Roasting gently browns the exterior and seals in the juices. Convection roasting uses the hidden bake element, the hidden convection element, the broil element and a fan to circulate the oven's heat evenly and continuously within the oven. The temperature probe can be used in this cooking mode. The oven can be programmed for Convection Roasting at any temperature between 170°F to 550°F with a default temperature of 350°F.



### Convection Roasting Tips:

- Use the broiler pan and grid, and the roasting rack (Figure 1). The broiler pan will catch grease spills and the grid will help prevent spatters. The roasting rack will hold the meat.
- Place an oven rack on rack position 2 (next-bottom).
- Make sure the roasting rack is securely seated on the grid in the broiler pan. The roasting rack fits on the grid allowing the heated air to circulate under the food for even cooking and helps to increase browning on the underside.
- There is no need to reduce the convection temperature or to use the Convection Convert feature with this cooking mode.
- **DO NOT** use the broiler pan without the grid or cover the grid with aluminum foil.
- Always pull the rack out to the stop position before removing food.
- Position food (fat side up) on the roasting rack.

### To set a Convection Roast Temperature of 350°F:

1. Arrange interior oven racks.
2. Select oven by pressing **UPPER OVEN** UPPER OVEN.
3. Press **CONVECTION ROAST** .
4. Press **START** .
5. The Temperature Probe, Cook Time, Timer, End Time and Rapid Preheat features can be set to control your cooking time (read their sections for directions).
6. Remove food. Always use oven mitts when removing hot pans from the oven.
7. Press **CANCEL**  to stop or cancel the Convection Roast feature at any time.

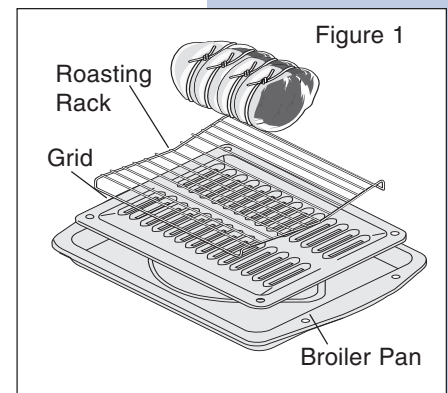

Convection Roasting Chart					
Meat		Weight	Oven Temp	Internal Temp	Min per lb.
Beef	Standing rib roast	4 to 6 lbs.	350° F	*	25-30
	Rib eye roast	4 to 6 lbs.	350° F	*	25-30
	Tenderloin roast	2 to 3 lbs.	400° F	*	15-25
Poultry	Turkey, whole**	12 to 16 lbs.	325° F	180° F	8-10
	Turkey, whole**	16 to 20 lbs.	325° F	180° F	10-15
	Turkey, whole**	20 to 24 lbs.	325° F	180° F	12-16
	Chicken	3 to 4 lbs.	350-375° F	180° F	12-16
Pork	Ham roast, fresh	4 to 6 lbs.	325° F	160° F	30-40
	Shoulder blade roast	4 to 6 lbs.	325° F	160° F	20-30
	Loin	3 to 4 lbs.	325° F	160° F	20-25
	Pre-cooked ham	5 to 7 lbs.	325° F	160° F	30-40

\* For beef: med rare 145°F, med 160°F, well done 170°F

\*\* Stuffed turkey requires additional roasting time. Shield legs and breast with foil to prevent overbrowning and drying of the skin.

## CONVECTION BROILING



Use this mode for thicker cuts of meat, fish and poultry. The Convection Broiling gently browns the exterior and seals in the juices. Convection broiling uses the broil element and a fan to circulate the oven's heat evenly and continuously within the oven. The temperature probe cannot be used in this cooking mode. The oven can be programmed for Convection Broiling at any temperature between 300°F to 550°F with a default temperature of 550°F.

### Convection Broiling Tips:

- For optimum browning, preheat the broil element for 2 minutes.
- Broil one side until the food is browned; turn and cook on the second side. Season and serve.
- Always pull the rack out to the "stop" position before turning or removing food.
- Always use the broiler pan and its grid when broiling. It allows the dripping grease to be kept away from the high heat of the broil element (see Figure 1).
- **DO NOT** use the broil pan without the insert. **DO NOT cover the broil pan insert with foil.** The exposed grease could catch fire. **DO NOT** use the roasting rack when broiling.
- Convection broiling is generally faster than conventional broiling. Check for doneness at the minimum recommended time.

**IMPORTANT:** Always use this cooking mode with the oven door closed or the fan will not turn on.

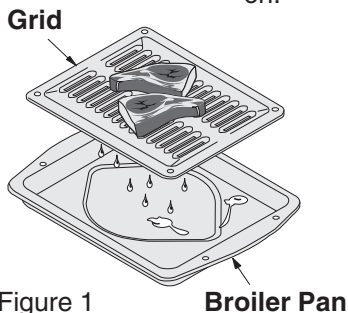





Figure 1

### To set a Convection Broil Temperature of 550°F:

1. Arrange interior oven racks.
2. Select oven by pressing **UPPER OVEN** UPPER OVEN.
3. Press **CONVECTION BROIL** .
4. Press **START** .
5. Place food in the oven after 2 minutes.
6. Turn food when the top side is browned and cook on the second side.
7. Remove food. Always use oven mitts when removing hot pans from the oven.
8. Press **CANCEL**  to stop or cancel the Convection Broil feature at any time.

**⚠ WARNING** Should an oven fire occur, leave the oven door closed and turn off the oven. If the fire continues, throw baking soda on the fire or use a fire extinguisher. **DO NOT** put water or flour on the fire. Flour may be explosive and water can cause a grease fire to spread and cause personal injury.



## KEEP WARM

This mode is best for keeping oven baked foods warm for serving after cooking has finished. The Keep Warm feature uses the hidden bake element to maintain the temperature within the oven. The Keep Warm feature may be used with Multi-Stage (refer to its section for directions) if you wish to have the Keep Warm feature turn ON automatically when cooking has finished. The oven can be programmed for Keep Warm at any temperature between 150°F to 190°F with a default temperature of 170°F.





### Keep Warm Tips for Upper Oven:

- Always start with hot food.
- Do not use the Keep Warm feature to heat cold food.
- Food in heat-safe glass and glass ceramic containers may need higher temperature settings compared to food in regular containers.
- Avoid repeated openings of the oven, it will allow hot air to escape and the food to cool.
- Aluminum foil may be used to cover food to increase moisture content.

### Keep Warm Tips for Lower Oven:

- Follow recommendations for lower oven cooking modes in the **Setting Lower Oven** section of this manual.

### To set a Keep Warm Temperature of 170°F:

1. Arrange interior oven racks (for upper oven only).
2. Select oven by pressing **UPPER OVEN** <sup>UPPER</sup><sub>OVEN</sub> or **LOWER OVEN** <sup>LOWER</sup><sub>OVEN</sub>.
3. Press **KEEP WARM** .
4. Press **START** .
5. The Multi-Stage, Cook Time, Timer and End Time features can be set to control your warming time (read their sections for directions).
6. Remove food. Always use oven mitts when removing hot pans from the oven.
7. Press **CANCEL**  to stop or cancel the Keep Warm feature at any time.

## SLOW COOK





This mode may be used to cook foods more slowly, at lower oven temperatures and provide cooking results much the same way as a Slow Cooker or Crock-Pot. The Slow Cook feature is ideal for roasting beef, pork & poultry. Slow Cooking meats may result in the exterior of meats becoming dark but not burnt. This is normal. The Slow Cook mode uses the hidden bake element to maintain a low temperature in the oven. The temperature probe cannot be used in this cooking mode. There are 2 settings available, high (HI) or low (LO). The maximum cook time for the Slow Cook feature is 12 hours unless the oven control has been changed to the Continuous Bake mode or the Sabbath mode has been activated.

### Slow Cook Tips:

- Completely thaw all frozen foods before cooking with the Slow Cook feature.
- When using a single rack, position it in the center of the oven.
- Position multiple racks to accommodate size of cooking utensils when cooking multiple food items.
- Do not open the oven door often or leave the door open when checking foods. If the oven heat escapes often, the Slow Cook time may need to be extended.
- Cover the foods to keep them moist or use a loose or vented type cover to allow foods to turn crisp or brown.
- Cook times will vary; depending on the weight, fat content, bone & the shape of the meat.
- Use the recipe's recommended food temperature and a food thermometer to determine when the food is done.
- Preheating the oven will not be necessary when using the Slow Cook feature.
- Add any cream or cheese sauces during the last hour of cooking.

### To set a Slow Cook:

1. Arrange interior oven racks and place food in the oven.
2. Select oven by pressing **UPPER OVEN** UPPER OVEN or **LOWER OVEN** LOWER OVEN.
3. Press **SLOW COOK** .
4. Press  $\overset{+}{\text{hi}}$  for high (**HI**) setting or  $\overset{-}{\text{lo}}$  low (**Lo**) setting.
5. Press **START** .
6. The Cook Time, Timer and End Time features can be set to control your Slow Cook time (read their sections for directions).
7. Remove food. Always use oven mitts when removing hot pans from the oven.
8. Press **CANCEL**  to stop or cancel the Slow Cook feature at any time.

## DEHYDRATING



This mode dries foods with heat from the bake and the convection element. The heat is circulated throughout the oven by the convection fan. Dehydrating is used to dry and/or preserve foods such as fruits, meats, vegetables and herbs. This mode holds an optimum low temperature while circulating the heated air to slowly remove moisture. The oven can be programmed for Dehydrating at any temperature between 100°F to 225°F with a default temperature of 120°F.



### Dehydrating Tips:

- Do not preheat the oven.
- Multiple racks can be used simultaneously.
- Drying times vary depending on the moisture and sugar content of the food, the size of the pieces, the amount being dried and the humidity in the air.
- Check food at the minimum drying time.
- Treat fruits with antioxidants to avoid discoloration.
- Consult a food preservation book or a library for additional information.

### To set a Dehydrate Temperature of 120°F:

1. Arrange interior oven racks and place food.
2. Select oven by pressing **UPPER OVEN** UPPER OVEN.
3. Press **DEHYDRATE** .
4. Press **START**  to begin dehydrating.
5. Remove food. Always use oven mitts when removing hot pans from the oven.
6. Press **CANCEL**  to stop or cancel the Dehydrate feature at any time.

## DEFROSTING



This mode uses a fan controlled defrosting to quickly warm your food at the room's temperature. Suitable for delicate items such as cream cakes, this light defrost circulates room temperature air around the food slowly, defrosting it hygienically in less time!



### Defrosting Tips:

- Place an oven rack on rack position 2 (next-bottom).

### To set a Defrost:

1. Arrange interior oven racks and place food in the oven.
2. Select oven by pressing **UPPER OVEN** UPPER OVEN.
3. Press **DEFROST** .
4. Press **START**  to start the defrosting. A "dEF" message is displayed when active.
5. The Cook Time, End Time and Timer features can be set to control your Defrost time (read their sections for directions).
6. Remove food.
7. Press **CANCEL**  to stop or cancel the Defrost feature at any time.

**CAUTION** It is not recommended to use food that can spoil due to bacteria growth. Defrost only items which are recommended for countertop thawing.

## BREAD PROOFING





Proofing bread prepares the dough for baking by activating the yeast. This feature is ideal for proofing, or rising bread dough. The oven can be programmed for Bread Proofing at any temperature between 85°F to 100°F with a default temperature of 100°F. The temperature visual display is not available for this function.

### Bread Proofing Tips:

- No need to preheat for this feature.
- Proof bread until dough has doubled in bulk.
- For best results, place a shallow pan with 1 to 3 cups of boiling hot water on the lowest rack position to keep the air moist inside the oven cavity.
- Allow at least 1" between edge of pan and walls of the oven.
- Limit frequent door openings to prevent losing heat and lengthening proofing time.

### To set a Bread Proof temperature of 100°F:

1. Arrange interior oven racks and place bread dough in the oven.
2. Select oven by pressing **UPPER OVEN** UPPER OVEN.
3. Press **BREAD PROOF** .
4. Press **START**  to begin the bread proofing.
5. The Cook Time, Timer and End Time features can be set to control your Bread Proof time (read their sections for directions).
6. Remove food.
7. Press **CANCEL**  to stop or cancel the Bread Proof feature at any time.

### To change a Bread Proof temperature while the function is active:

1. Select oven by pressing **UPPER OVEN** UPPER OVEN.
2. Press the **HI** <sup>+</sup><sub>hi</sub> or **LO** <sup>-</sup><sub>lo</sub> pads to get to the desired temperature.
3. Press **START**  to continue the bread proofing with the new setting.

## PERFECT TURKEY

This mode uses the temperature probe to control precisely the cooking of a perfect turkey. The convection system gently browns the turkey's exterior and seals in the juices. The temperature probe is **required** with this cooking mode (read its section on next page for more details). The oven can be programmed for Perfect Turkey at any temperature between 170°F to 550°F with a default temperature of 325°F. The probe default temperature for the perfect turkey feature is 180°F.





### Perfect Turkey Tips:

- Thaw the turkey in the refrigerator at least 24 hours per 5 lbs before cooking the bird.
- Use the broiler pan and grid, and the roasting rack. The broiler pan will catch grease spills and the grid will help prevent spatters. The roasting rack will hold the turkey.
- Place an oven rack on rack position 2 (next-bottom).
- Make sure the roasting rack is securely seated on the grid in the broiler pan. The roasting rack fits on the grid allowing the heated air to circulate under the food for even cooking and helps to increase browning on the underside.

### To set a Perfect Turkey of 325°F:

1. Arrange interior oven racks and place food in the oven.
2. Insert the meat probe into the bird and connect it in the oven (read the probe section on next page for more details).
3. Select oven by pressing **UPPER OVEN** UPPER OVEN.
4. Press **PERFECT TURKEY** . A temperature can be entered if another value than the default is needed.

Optional : Press **PROBE**  if you wish to change the probe target temperature (see PROBE section).

5. Press **START** .
6. Remove food from the oven when the temperature probe chime signals that the oven has reached the set target temperature.
7. Press **CANCEL**  to stop or cancel the Perfect Turkey feature at any time.

Perfect Turkey Chart		Weight	Oven Temp	Internal Temp	Min per lb.
Poultry	Turkey, whole*	12 to 16 lbs.	325° F	180° F	8-10
	Turkey, whole*	16 to 20 lbs.	325° F	180° F	10-15
	Turkey, whole*	20 to 24 lbs.	325° F	180° F	12-16
	Chicken	3 to 4 lbs.	350-375° F	180° F	12-16

\* Stuffed turkey requires additional roasting time. Shield legs and breast with foil to prevent overbrowning and drying of the skin.

# 34 Section B - Electronic Controls

## TEMPERATURE PROBE



For many foods, especially roasts and poultry, testing the internal temperature is the best method to insure properly cooked food. The Temperature Probe gets the exact temperature you desire without having to guess. This feature can be used with Bake, Convection Bake, Convection Roast and Perfect Turkey cooking modes. The oven can be programmed for Probe at any temperature between 130°F to 210°F with a default temperature of 170°F. This unit is equipped with one temperature probe entry in the upper oven.

### IMPORTANT:

1. Use only the probe supplied with your appliance; any other may result in damage to the probe or the appliance.
2. Handle the Temperature Probe carefully when inserting and removing it from the food and outlet.
3. Do not use tongs to pull the cable when inserting or removing the Probe. It could damage the Probe.
4. Defrost your food completely before inserting the Probe to avoid breaking it.
5. Never leave or store the Temperature Probe inside the oven when not in use.
6. To prevent the possibility of burns, carefully unplug the Temperature Probe using hot pads.

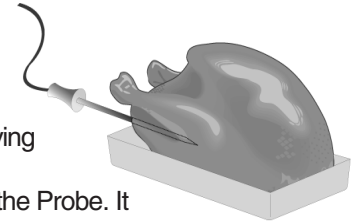







Figure 1

### Proper Temperature Probe Placement:

1. Always insert the probe so that the tip rests in the center of the thickest part of the meat. Do not allow probe to touch bone, fat, gristle or pan.
2. For bone-in ham or lamb, insert the Probe into the center of the lowest large muscle or joint. For dishes such as meat loaf or casseroles, insert the Probe into the center of the food. When cooking fish, insert the Probe from just above the gill into the meatiest area, parallel to the backbone.
3. For whole poultry (chicken, turkey, etc.), insert the probe into the thickest part of the inner thigh from below and parallel to the leg (see figure 1).

### Setting the Oven when using the Temperature Probe:













1. Insert the Temperature Probe into the food (see Proper Temperature Probe Placement above).
2. Plug the Temperature Probe into its outlet in the oven. (**The outlet is located on the top left hand side of the cavity wall, near front of the oven**). Always insert the probe into a cool oven. Make sure it is pushed all the way into the outlet. Close the oven door.
3. Select oven by pressing either **UPPER OVEN** UPPER OVEN.
4. Select a cooking mode. A target temperature must be set to trigger the buzzer when the food reaches the set temperature. Press **COOK OPTIONS**  to bring up the cook options items and press **PROBE**  pad to enter the temperature. Adjust temperature to the desired setting using the numeric pads or just press **START**  to use the default target temperature of 170°F. The pads  $+$  hi or  $-$  lo can also be pressed to raise or lower the temperature. The target temperature setting will be accepted after the **START**  pad is pressed.
5. At any time during the cooking, the **PROBE**  pad can be pressed once to display the actual meat temperature or pressed twice to display the target temperature. When on the target temperature display, a new temperature can be entered. After 5-8 seconds, the display will go back to showing the oven temperature.
6. When the food reach the target temperature, the oven will go into a **KEEP WARM** mode until you press **CANCEL** .

## MULTI STAGE



This feature enables you to perform sequential cooking at the touch of a button. Its purpose is to program a queue of up to three cooking modes with individual cooking time and temperatures in a sequence. This feature can be used with most cooking modes; Baking, Broiling, Convection Baking, Convection Roasting, Convection Broiling, Keep Warm and Bread Proof. A Cook Time can be programmed with your cooking mode and then queued. No Auto-Suggest default temperature is provided with this feature. Any stage programmed with Broil or Convection Broil cannot last longer than 10 minutes. A proper cook time and a set temperature are required for every stage programming. At least two stages must be programmed before a Multi-Stage cooking operation starts.

### To set a Multi Stage sequence (Timed Convection Bake, Timed Broil, Keep Warm):

1. Arrange interior oven racks and place food.
  2. Select oven by pressing **UPPER OVEN** .
  3. Press **MULTI STAGE**  <sup>1</sup>/<sub>2</sub>/<sub>3</sub>.
- 
- Stage 1*
4. Press **CONVECTION BAKE** . "000" will flash in the display prompting to enter a temperature.
  5. Enter a temperature using the numeric pads **0** to **9**.
  6. Press **START** . "00:00" will start flashing in the display prompting to enter a cook time.
  7. Enter a cook time using the numeric pads **0** to **9**.
  8. Press **START** . The Multi-Stage indicator will now display the 2nd stage.
- 
- Stage 2*
9. Press **BROIL** . "000" will start flashing in the display prompting to enter a temperature.
  10. Enter a temperature using the numeric pads **0** to **9**.
  11. Press **START** . "00:00" will start flashing in the display prompting to enter a cook time.
  12. Enter a cook time using the numeric pads **0** to **9**.
  13. Press **START** . The Multi-Stage indicator will now display the 3rd stage. If a third stage is not needed, press **START**  a second time. This will start the cooking sequence.
- 
- Stage 3*
14. Press **KEEP WARM** . "000" will start flashing in the display prompting to enter a temperature.
  15. Enter a temperature using the numeric pads **0** to **9**.
  16. Press **START** . "00:00" will start flashing in the display prompting to enter a cook time.
  17. Enter a cook time using the numeric pads **0** to **9**.
  18. Press **START**  **twice**. The cooking sequence will begin.
- 
- Canceling*
19. At the end of the sequence, the display will show "End" and a chime will sound.
  20. Remove food.
  21. Press **CANCEL**  to stop or cancel the Multi-Stage sequence at any time.

# 36 Section B - Electronic Controls



## MULTI STAGE (CONTINUED)

1  
2  
3

### To review and edit a Multi Stage sequence:

Once the first and second stages have been programmed, the control displays a Review Screen. During this mode, the temperature display is cleared, the stage numbers are lit and the numeric pads corresponding to the programmed stages are lit.

**To review a programmed stage** cooking mode, press the corresponding numeric pad. The temperature and cook time pads will light up and the control will display the programmed values.

**To edit a programmed stage** cooking mode being reviewed, press **CANCEL** . This will bring you back to the programming steps explained in the previous page. The third stage cannot be edited but can be deleted by pressing **CANCEL**  on the review screen. To return to the review screen from the programming screen, at any time press **MULTI STAGE** .

**To begin the cooking sequence** from the review screen, simply press **START** .







## USER PREFERENCES

The User Preferences menu includes all user defined options. This feature enables you to control the various options of the electronic controls. This menu features the Time of Day, Celsius or Fahrenheit display mode, Continuous Bake or 12 Hour Energy Saving modes, Clock display or No-Clock display, 12 Hours Time of Day or 24 Hours Time of Day, Audio Control, and Adjusting the oven temperature. The User Preferences menu is only available when the oven is not being used (not cooking).



### To browse through the User Preferences menu:

1. Press **USER PREF**  to bring up the User Preferences menu.
2. Press **USER PREF**  again to browse through the menu pages.
3. Press  $\overset{+}{hi}$  or  $\overset{-}{lo}$  to toggle between the available options.
4. Press **START**  while the chosen option is on display to change.
5. Press **CANCEL**  when finished to get back to the standard oven display.

### User Preferences menu items:



- **CLO 12:00**; Setting the clock.
- **CLO on**; Clock on/off.
- **CLO 12hr**; 12/24 hour time of day display.
- **UPO**; Adjusting oven temperature.
- **F-C F** ; Fahrenheit / Celsius display.
- **AUd** ; Audio on/off and volume.
- **E S on** ; 12 hour Energy Saving on/off.
- **rSt** ; Reset to default factory settings.

## SETTING THE CLOCK - TIME OF DAY

The clock may be set for 12 or 24 hour time of day operation (see advanced settings section). The clock has been preset at the factory for the 12 hour operation. When the range is first plugged in, or when the power supply to the range has been interrupted, the display will show "**CLO 12:00**". The clock must be set before the oven can be used.

When power to the unit has been interrupted, "**12:00**" appears and flashes in the display. To set the Clock in this case, skip step 1 in the example below and follow steps 2 and 3.

### To set the clock (example for 1:30):

1. Press **USER PREF**  until you get to the **CLO 12:00** menu page.
2. Press **1** **3** **0** pads to set the time of day to 1:30. The pads  $\overset{+}{hi}$  or  $\overset{-}{lo}$  can also be pressed to raise or lower the actual time displayed.
3. Press **START**  to accept the changes and go back to user preferences menu display.

# 38 Section B - Electronic Controls



## USER PREFERENCES (CONTINUED)



### SETTING CLOCK DISPLAY — ON OR OFF

The oven control can be programmed to display the time of day or not. The oven has been preset at the factory to display the time of day.



#### Changing clock display between ON and OFF:

1. Press **USER PREF**  until you get to the **CLO on** menu page.
2. Press  $\overset{-}{\text{lo}}$  or  $\overset{+}{\text{hi}}$  to toggle between displaying or hiding the clock.
3. Press **START**  to accept the changes and go back to user preferences menu display.

### SETTING TIME OF DAY DISPLAY — 12 OR 24 HOURS

The oven control can be programmed to display time of day in 12 hours or 24 hours mode. The oven has been preset at the factory to display in 12 hours mode.



#### Changing between 12 or 24 hour time of day display:

1. Press **USER PREF**  until you get to the **CLO 12hr** menu page.
2. Press  $\overset{-}{\text{lo}}$  or  $\overset{+}{\text{hi}}$  to toggle the display of the clock in 12 or 24 hours.
3. Press **START**  to accept the changes and go back to user preferences menu display.
4. Remember to set your clock after changing the time of day display mode.

### ADJUSTING OVEN TEMPERATURE

The temperature in the oven has been pre-set at the factory. When first using the oven, be sure to follow recipe times and temperatures. If you think the oven is too hot or too cool, the temperature in the oven can be adjusted. Before adjusting, test a recipe by using a temperature setting that is higher or lower than the recommended temperature. The baking results should help you to decide how much of an adjustment is needed. Each oven can be individually adjusted.

#### To adjust the oven temperature:



1. Press **USER PREFERENCES**  until you get to the **UPO** menu page.
2. To select the oven you want to adjust, press **USER PREFERENCES**  again to toggle between the upper and the lower display.
3. Enter the temperature by pressing the  $\overset{+}{\text{hi}}$  or  $\overset{-}{\text{lo}}$  pads. The temperature can only be adjusted by  $\pm 35^{\circ}\text{F}$ .
4. Press **START**  to accept the changes and go back to user preferences menu display.

## USER PREFERENCES (CONTINUED)

### SETTING TEMPERATURE DISPLAY — FAHRENHEIT OR CELSIUS

The oven control can be programmed to display temperatures in Fahrenheit or Celsius. The oven has been preset at the factory to display in Fahrenheit.



#### To change display from Fahrenheit to Celsius or Celsius to Fahrenheit:

1. Press **USER PREF**  until you get to the **F-C F** menu page.
2. Press  $\overset{+}{hi}$  or  $\overset{-}{lo}$  to toggle between the °C and °F display options.
3. Press **START**  to accept the changes and go back to user preferences menu display.

### AUDIO CONTROL

The Audio Control feature allows the oven control to be operated without sounds or beeps whenever necessary. If desired the control can be programmed for silent operation and later returned to operating with all the default sounds and beeps. The volume of the beeps can also be adjusted.



#### To change the audio mode or audio volume:

1. Press **USER PREF**  until you get to the **AUd** menu page.
2. Press  $\overset{+}{hi}$  or  $\overset{-}{lo}$  to toggle between the available volume settings. **AUd 5** for the highest volume setting to **AUd 1** for the lowest volume. **AUd OFF** to disable the beeps.
3. Press **START**  to accept the changes and go back to user preferences menu display.

### SETTING CONTINUOUS BAKE OR 12 HOUR ENERGY SAVING

The oven control has a factory preset built-in 12 Hour Energy Saving feature that will shut off the oven if the oven control is left on for more than 11 hours and 59 minutes. The oven can be programmed to override this feature for Continuous Baking.



#### Changing between 12 hour energy saving and continuous bake:

1. Press **USER PREF**  until you get to the **E S** menu page.
2. Press  $\overset{+}{hi}$  or  $\overset{-}{lo}$  to toggle the energy saving setting on and off.
3. Press **START**  to accept the changes and go back to user preferences menu display.

### RE-SETTING TO DEFAULT FACTORY SETTINGS

The oven control can be set to return to its original factory settings. This includes: Setting the Clock ON/OFF to ON, Setting the clock display mode to 12h, Display mode to Fahrenheit, Setting the oven temperature adjustment to zero, Setting audio level to 5 and Enabling the 12h energy saving mode. Resetting the control also erases the My Favorite recipes.

#### To reset the oven control to its original settings:

1. Press **USER PREF**  until you get to the **rSt no** menu page.
2. Press  $\overset{+}{hi}$  or  $\overset{-}{lo}$  to select **YES**.
3. Press **START**  to reset to default factory settings.



## MY FAVORITES

1





2

3

The Favorites settings allows you to save your most frequently used or most complex cooking sequences. This feature will save the cooking mode, the target temperature and the cooktime (if any). The oven can recall up to six cooking sequences from its internal memory, three for each oven, which are easily accessible from a one touch button. These functions can be used with all cooking modes and features.



### To save a Favorite (example is a 450°F Bake for 30 minutes):

- Saving a Favorite can only be done for an oven which is currently in operation.

1. Select oven by pressing either **UPPER OVEN** UPPER OVEN or **LOWER OVEN** LOWER OVEN.
2. Press **BAKE** . The default temperature will appear in the display.
3. Enter temperature needed; **4 5 0**.
4. Press **COOK OPTIONS**  to bring up the cook options items.
5. Press **COOK TIME** .
6. Enter time needed; **3 0**.
7. Press **START** .
8. Press and hold for 3 seconds any **MY FAVORITE**  pad. Notice that the red indicator above the key will light up.

### To recall a Favorite:

- Recalling a Favorite can only be done for an oven which is not currently in operation.

1. Select oven by pressing either **UPPER OVEN** UPPER OVEN or **LOWER OVEN** LOWER OVEN.
2. Press any **MY FAVORITE**  pad which is currently lighted up.
3. Press **START** .

### To overwrite a Favorite:

1. To overwrite a My Favorite simply start a new cooking sequence and save it into the same My Favorite location (1, 2 or 3) for the selected oven as shown in example above. The new My Favorite settings will overwrite the old ones.



### To delete a Favorite:

1. Select oven by pressing either **UPPER OVEN** UPPER OVEN or **LOWER OVEN** LOWER OVEN.
2. Press the currently lighted up **MY FAVORITE**  pad you wish to delete for **3 seconds**.







## SABBATH FEATURE (FOR USE ON THE JEWISH SABBATH & HOLIDAYS)

The  $HI_{hi}^{+}$  and  $LO_{lo}^{-}$  pads are used to set the Sabbath feature. The Sabbath feature may only be used with the **BAKE**  pad. The oven temperature may be set higher or lower after setting the Sabbath feature (the oven temperature adjustment feature should be used only during Jewish Holidays), however the display will not visibly show or provide any audible tones indicating whether the change occurred correctly. Once the oven is properly set using Bake with the Sabbath feature active, the oven will remain continuously ON until cancelled. This will override the factory preset 12-Hour Energy Saving feature.

If the oven light will be needed during the Sabbath, press **OVEN LIGHT**  before activating the Sabbath feature. Once the oven light is turned ON and the Sabbath feature is active, the oven light will remain ON until the Sabbath feature is turned OFF. If the oven light needs to be OFF, be sure to turn the oven light OFF before activating the Sabbath feature.

**IMPORTANT NOTES:** It is not advised to attempt to activate any other program feature other than **BAKE** while the Sabbath feature is active. ONLY the following key pads will function after setting the Sabbath feature; **0** to **9**, **BAKE** , **START** , **CANCEL** ,  $HI_{hi}^{+}$  and  $LO_{lo}^{-}$ . **ALL OTHER KEYPADS** will not function once the Sabbath feature is properly activated.

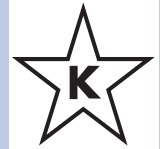

### To Program the Upper Oven to Begin Baking Immediately & Activate the Sabbath feature (example: baking at 350°F)

1. Place the food in the oven.
2. Select oven by pressing either **UPPER OVEN**  or **LOWER OVEN** .
3. Press **BAKE** .
4. If you desire to set the oven control for a **COOK TIME**  do so at this time. If not, skip this step and continue to step 5. Refer to their section for complete instructions. Remember the oven will shut down after using **COOK TIME**  and therefore may only be used once during the Sabbath/Jewish Holidays.
5. Press **START** .
6. The oven will turn ON and begin heating immediately.
7. Press and hold both the  $HI_{hi}^{+}$  and  $LO_{lo}^{-}$  pads for at least 3 seconds. **SAb** will appear in the oven display and **Sb** in the cooktop displays. Once **SAb** appears in the display the oven control will no longer beep or display any further changes and the oven is properly set for the Sabbath feature.



## SABBATH FEATURE (CONTINUED)



**Note:** You may change the oven temperature once baking has started. Press **UPPER OVEN**, **BAKE** , the numeric key pads for the temperature you want (example for 425°F press **4**, **2**, **5**) and then press **START**  **TWICE** (for Jewish Holidays only). Remember that **the oven control will no longer beep or display any further changes** once the oven is set for the Sabbath feature.

8. The oven may be turned OFF at any time by pressing **CANCEL**  pad (this will turn the oven OFF only). To turn OFF the Sabbath feature press and hold both the **HI<sub>hi</sub><sup>+</sup>** and **LO<sub>lo</sub><sup>-</sup>** pads for at least 3 seconds. **SAb** will disappear from the display.

Should you experience a power failure or interruption, the oven will shut off. When power is returned the oven will not turn back on automatically. **SF** (Sabbath Failure) will be displayed in the oven control display and the surface element displays. The oven will remember that it is set for the Sabbath and the food may be safely removed from the oven while still in the Sabbath feature, however the oven cannot be turned back on until after the Sabbath. After the Sabbath observance turn OFF the Sabbath feature. Press and hold both the **HI<sub>hi</sub><sup>+</sup>** and **LO<sub>lo</sub><sup>-</sup>** pads for at least 3 seconds. **SAb** will disappear from the display and the oven may be used with all normal functions. For further assistance, guidelines for proper usage, and a complete list of models with the Sabbath feature, please visit the web at <http://www.star-k.org>.

### Notes for the use of the cooktop in Sabbath mode:

- When the Sabbath feature is enabled on the oven control, it is also enabled on the cooktop. To activate the Sabbath feature, it is not necessary to have one burner ON, but it is necessary to have a Bake function active in the oven.
- When the Sabbath feature is enabled, a surface element can be turned ON by pressing the ON/OFF pad. The element will turn ON 15 to 30 seconds after the ON/OFF pad was pressed.
- When the Sabbath feature is enabled, the power level of an active element can be changed. The change will take effect after a 15 to 30 seconds delay. The element size (inner/outer) CANNOT be changed.
- All surface element displays will show "**Sb**" regardless of if the element is ON or OFF. All red rings will be illuminated, regardless of the burner size.

## STARTING SELF-CLEAN CYCLE

A self-cleaning oven cleans itself with high temperatures (well above cooking temperatures) which eliminate soil completely or reduce it to a fine powdered ash you can whisk away with damp cloth. If you are planning to use the oven directly after a self-clean cycle remember to allow time for the oven to cool down and the oven door to unlock. This normally takes about one hour.



### To set the controls for a Self-Cleaning cycle:

1. Remove the oven racks and the racks supports.
2. Be sure the clock is set with the correct time of day and the oven door is closed.
3. Press **CLEAN**
4. Press **LITE** ● for a 2 hour self-clean, or press **MEDIUM** ●● for 3 hours, or press **HEAVY** ●●● for 4 hours.
5. Press **START**
6. As soon as the control is set, the motor driven oven door lock will begin to close automatically. Once the door has been locked the "DOOR

Note: Allow about 15 seconds for the oven door lock to close.

### To set the controls for a delayed Self-Cleaning cycle:

1. Follow the instructions above.
2. Press **COOK OPTIONS**
3. Press **END TIME**
4. Enter time of day needed for the end of the cycle (example for "6:00";
5. Press **START**

### When the Self-Clean Cycle is Completed:

1. The time of day and "DOOR
2. The display will show an "Hot" message while the oven is still too hot to open door.
3. Once the oven has cooled down for 1 HOUR, and the "DOOR

### Stopping or Interrupting a Self-Cleaning Cycle:

If it becomes necessary to stop or interrupt a self-cleaning cycle due to excessive smoke:

1. Press **CANCEL**
2. Once the oven has cooled down for approximately 1 HOUR and the "DOOR

**⚠ WARNING** During the self-cleaning cycle, the outside of the wall oven can become very hot to the touch. **DO NOT** leave small children unattended near the appliance; they may be burned if they touch the hot oven door surfaces.

**⚠ CAUTION** **DO NOT** force the oven door open. This can damage the automatic door locking system. Use care when opening the oven door after the self-cleaning cycle. Stand to the side of the oven when opening the door to allow hot air or steam to escape. The oven may still be VERY HOT.

## ELECTRONIC OVEN CONTROL

1. This self-cleaning controller offers Bake, Broil, Convection Bake, Convection Roasting and Convection Broil modes, Dehydrating, Defrosting, Temperature Probe, Perfect Turkey, Bread Proof, Keep Warm and Cleaning functions.
2. Convection operates with an element and a fan dedicated to convection.
3. This controller includes a display board, a relay board, and a convection fan and oven light control board.

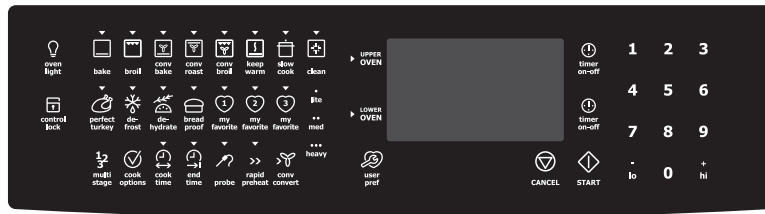
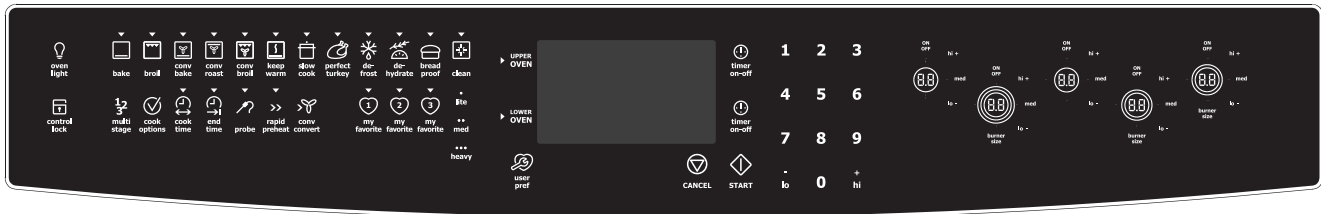

**NOTE:** The controllers are not field repairable. Only temperature settings can be changed. See oven calibration.

## ELECTRONIC OVEN CONTROL RELAY BOARD

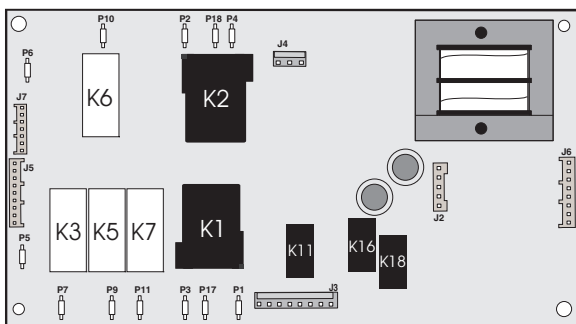

*This relay board serves to energize the upper and lower oven heating elements, door lock motor and cooling fan.*

- J2 - DC Power Output To Display Board
- J3 - AC Power Output (motor door latch, cooling fan) For Upper Oven
- J4 - Power Input (L1, Neutral)
- J5 - Relay Control Inputs (bake, broil and convection elements, motor door latch, DLB) For Upper Oven
- J6 - Relay Control Inputs (cooling fan) For Upper Oven
- J7 - Relay Control Inputs (bake element and DLB) For Lower Oven

### Relay Board Legend:

- K1. Double Line Break - Upper Oven
- K2. Double Line Break - Lower Oven
- K3. Broil Relay - Upper Oven
- K5. Bake Relay - Upper Oven
- K6. Bake Relay - Lower Oven
- K7. Convection Element Relay - Upper Oven
- K11. Motor Door Latch - Upper Oven
- K16. Cooling Fan Relay Low Speed - Upper Oven
- K18. Cooling Fan Relay High Speed - Upper Oven

- P1 - L2 Out, Upper Oven
- P2 - L2 Out, Lower Oven
- P3 - L2 In, Upper Oven
- P4 & P17 - Not Used
- P5 - L1, Upper Oven
- P6 - L1, Lower Oven
- P7 - Broil, Upper Oven
- P9 - Bake, Upper Oven
- P10 - Bake, Lower Oven
- P11 - Convection Element, Upper Oven
- P18 - L2 In, Lower Oven



## ELECTRONIC SURFACE ELEMENT CONTROL (ESEC)

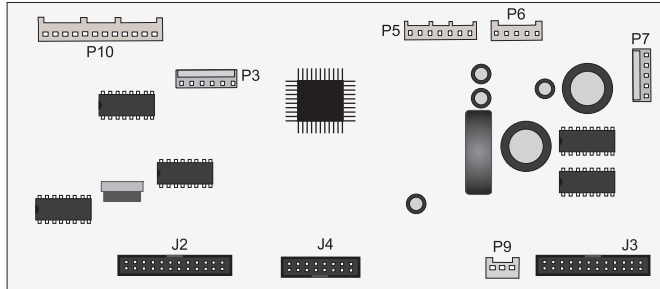

**User Interface Board (UIB)**

### User Interface Board (UIB) Legend:

- J2. Connector for Touch Panel LEDs and Display Indicators
- J3. Connector for Touch Panel LEDs and Display Indicators
- J4. Connector for Keyboard (Touch Panel)
- P3. Micro Programming Header (Not Used)
- P5. Connector for the hot element indicators from Relay Board
- P6. Power Supply Input (from relay board)
- P7. Power Supply Input (from power supply board for touch panel LEDs)
- P9. Communication with Oven Control
- P10. Surface Elements Relay Controls

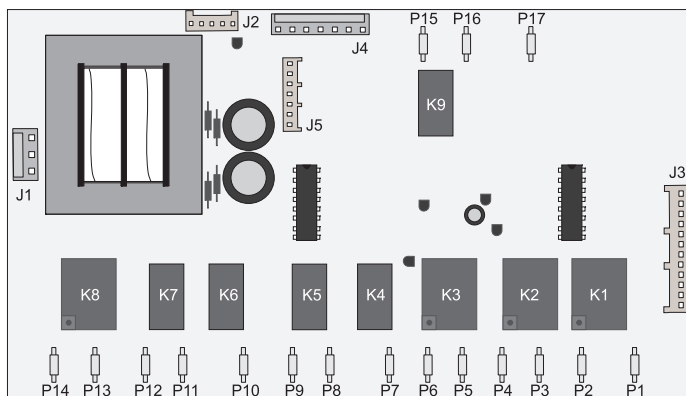

**ESEC Relay Board**

### ESEC Relay Board Legend:

- K1. Right Front Inner Element Relay
- K2. Right Front Outer Element Relay
- K3. Left Front Inner Element Relay
- K4. Left Front Middle Element Relay
- K5. Left Front Outer Element Relay
- K6. Right Rear Inner Element Relay
- K7. Right Rear Outer Element Relay
- K8. Left Rear Element Relay
- K9. Center Rear Element Relay

- P1. Right Front Inner Element Connection
- P2. Line In (120V AC)
- P3. Line In (120V AC)
- P4. Right Front Outer Element Connection
- P5. Left Front Inner Element Connection
- P6. Line In (120V AC)
- P7. Left Front Middle Element Connection
- P8. Line In (120V AC)
- P9. Left Front Outer Element Connection
- P10. Right Rear Element Connection
- P11. Line In (120V AC)
- P12. Right Rear Outer Element Connection
- P13. Line In (120V AC)
- P14. Left Rear Element Connection
- P15. Center Rear Element Connection
- P16. Line In (120V AC)
- P17. Not Used

- J1. Line Voltage Input (120V, Neutral)
- J2. Low Voltage Supply Output For UIB
- J3. Surface Element Relay Control Inputs
- J4. Surface Element Hot Signal Inputs
- J5. Hot Element Signals to UIB

### ELECTRONIC CONTROL DISPLAY BOARD

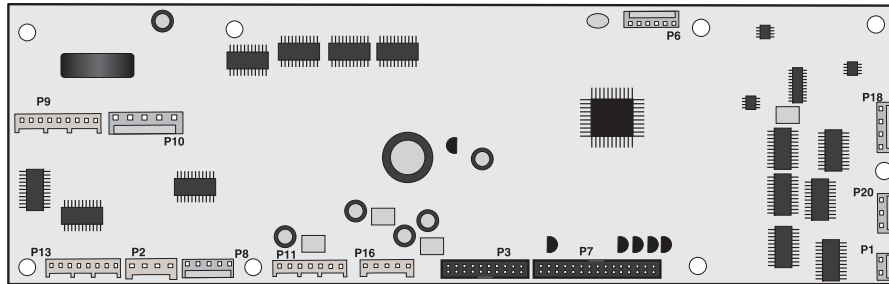

Electronic oven display board for electric ranges

#### Connector Legend:

- P1 - Upper Oven Probe Input
- P2 - Communication with Convection Fan and Oven Light Control Board, Communication with ESEC30 UIB (electric only)
- P3 - Keyboard (touch panel)
- P6 - Microprocessor Programming (not used)
- P7 - Touch Panel LEDs
- P8 - Power Supply Input for Display LEDs
- P9 - Relay Control Output (heating elements, DLB, motor door latch) for Upper Oven
- P10 - Switches Input (motor door latch switch, door switch, rack switch) for Upper Oven
- P11 - Relay Control Output (heating element, DLB) for Lower Oven
- P13 - Relay Control Output (cooling fan)
- P16 - DC Power Supply Input
- P18 - Meat Probe Input
- P20 - Lower Oven Probe Input

### POWER SUPPLY BOARD

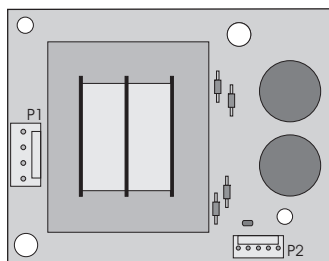

This board provides power to the oven control display.  
P1 - AC Power Input (L2 and Neutral)

P2 - DC Power Output

### CONVECTION FAN AND OVEN LIGHTS CONTROL BOARD

This board control the power output of the convection fan and oven lights.



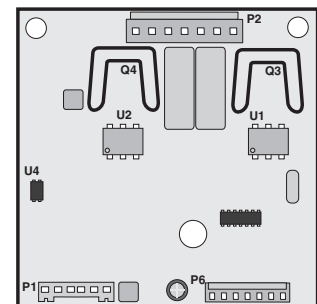



- P1 - Communication with display board and power supply input
- P2 - AC power output for convection fan and oven lights, power inputs (L1, neutral)
- P6 - Microprocessor programming (not used)



## CONVECTION MODE

The convection oven uses the addition of a fan and an element to heat and to move the air already in the oven. Moving the heated air helps to destratify the heat and cause uniform heat distribution. The air is drawn in through a fan shroud and the element located on the rear wall of the oven. It is then discharged around the outer edges of this shroud. The air circulates around the food and then enters the shroud again. As with conventional electric wall ovens, there is still an oven vent which discharges above the door. In preheat of non-convection cooking modes, the convection fan will be operating until the oven has reached the target temperature.

To set the control in convection mode, follow these steps:

1. Select upper oven by pressing **UPPER OVEN** .
2. Press **CONVECTION BAKE**  or **CONVECTION ROAST**  or **CONVECTION BROIL** .
3. Press **START** . The oven will automatically start and the fan will begin to run.
4. Press **CANCEL**  to stop or cancel the Convection feature at any time.

**NOTE:** The fan runs continuously while in the convection mode. The fan will stop if the door is opened while convection baking/roasting/broiling. The convection element will stop operating if the door is opened.

The speed of the convection fan will vary depending on which cooking function is used. Convection Roast uses a fast fan speed, while convection bake uses a slower fan speed.

## CONVECTION FAN MOTOR

The 120V fan motor is located on the outside of the rear of the oven.

The fan motor runs continuously while in convection mode unless the door is opened.

It is normal to see the fan speed changing depending on the cooking function that is used. This appliance uses the optimum fan speed for each convection function.

It is the Convection Fan and Oven Lights Control Board that modulates the speed of the convection fan. It uses the fan speed information communicated by the display board.

If the fan does not operate, check the following:

- The oven control display will give you an indication on when the convection fan should be on: rotating fan blades in the display means the fan should be ON. No rotating blades mean the convection fan is purposely not used.
- Verify proper operation of the door switch. If the control thinks the door is opened the convection fan will not work. If the oven light turns on when the door is opened and turn off when the door is closed then it's a good indication the door switch is good.
- If you are getting an F23 error code it means the display board is not able to communicate with the Convection Fan and Oven Lights Control Board, thus the convection fan will not operate. Check connections between the display board and the Convection Fan and Oven Lights Control Board. Refer to the fault code section for corrective actions.
- Check connections on the Convection Fan and Oven Lights Control Board. On connector P2: pin 3 should be Neutral, pin 5 should be L1 (120VAC) and pin 7 should go to the convection fan motor. The other terminal of the convection fan motor should be connected to Neutral.
- Fan motor coil resistance should be 15.0 ohm +/- 10%
- When the fan is ON you should see between 20 and 120VAC on the motor, depending on the fan speed.
- If there is no error code, the wiring is good and the fan coil is good then replace the Convection Fan and Oven Lights Control Board.

## OVEN CALIBRATION

Set the electronic oven control for normal baking at 350°F. Obtain an average oven temperature after a minimum of 5 cycles.

The oven calibration can be modified using the oven control display. Please refer to the Owner's Guide manual.

**Note:** Changing calibration affects all the cooking modes but not the clean and the broil modes.

## FIRST RISE

It is normal to see a temperature overshoot in the first rise of all modes when you monitor the temperature.

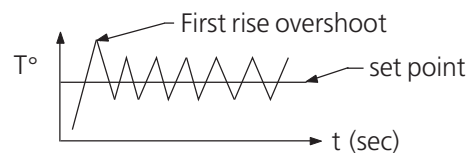

## ELECTRONIC OVEN CONTROL (FAULT CODES)

### ELECTRONIC OVEN CONTROL (EOC) FAULT CODE DESCRIPTIONS

**Note:** Generally speaking "F1X" implies a control failure, "F3X" an oven probe problem, and "F9X" a latch motor problem.

Failure Code/Condition/Cause	Suggested Corrective Action
<b>F10</b> Control has sensed a potential runaway oven condition. Control may have shorted relay, RTD sensor probe may have a gone bad.	<b>1)</b> Check RTD sensor probe and replace if necessary. If oven is overheating, disconnect power. If oven continues to overheat when power is reapplied, replace relay board and/or display board.
<b>F11</b> Shorted Key: a key has been detected as pressed for a long period and will be considered a shorted key alarm and will terminate all oven activity.	<b>1)</b> Press any key to clear the error. <b>2)</b> If fault returns, replace the keyboard (touch panel). <b>3)</b> If the problem persists, replace the display board.
<b>F13</b> Control's internal checksum may have become corrupted.	<b>1)</b> Press any key to clear the error. <b>2)</b> Disconnect power, wait 30 seconds and reapply power. If fault returns upon power-up, replace display board.
<b>F14</b> Misconnected keyboard cable	<b>1)</b> Verify connection between display board and touch panel (2 ribbon cables). Make sure the cables are well connected at both ends. <b>2)</b> If the cables are good, replace the touch panel. <b>3)</b> If the problem persists, replace the display board.
<b>F15</b> Controller self check failed.	<b>1)</b> Replace the display board.
<b>F23</b> The controller failed to communicate with the convection fan and oven lights control board.	<b>1)</b> Verify wiring between P2 on the display board and P2 on the convection fan and oven lights control board. <b>2)</b> If wiring is good, replace convection fan and oven lights board. <b>3)</b> If the problem persists, replace the display board.
<b>F25</b> No zero cross signal detected on the convection fan and oven lights control board.	<b>1)</b> Make sure L1 and Neutral are connected to the convection fan and oven lights control board on connector P2 (P2 pin 3= neutral/P2 pin 5=L1). <b>2)</b> If problem persists, replace the oven convection fan and oven lights control board.

## ELECTRONIC OVEN CONTROL (FAULT CODES) (continued)

### ELECTRONIC OVEN CONTROL (EOC) FAULT CODE DESCRIPTIONS

Failure Code/Condition/Cause	Suggested Corrective Action
<p><b>F30</b> Open RTD sensor probe/ wiring problem. Note: EOC may initially display an "F10", thinking a runaway condition exists.</p> <p><b>F31</b> Shorted RTD sensor probe / wiring problem.</p> <p>Note: <b>F30</b> or <b>F31</b> is displayed when oven is in active mode or an attempt to enter an active mode is made.</p>	<p><b>1)</b> Check wiring in probe circuit for possible open condition. <b>2)</b> Check RTD resistance at room temperature (compare to probe resistance chart). If resistance does not match the chart, replace the RTD sensor probe. <b>3)</b> Let the oven cool down and restart the function. <b>4)</b> If the problem persists, replace the display board.</p>
<p><b>F90</b> Door motor mechanism failure.</p>	<p><b>1)</b> Press any key to clear the error. <b>2)</b> If it does not eliminate the problem, turn off power for 30 seconds, then turn on power. <b>3)</b> Check wiring of Lock Motor, Lock Switch and Door Switch circuits. <b>4)</b> Unplug the lock motor from the board and apply power (L1) directly to the Lock Motor. If the motor does not rotate, replace Lock Motor Assembly. <b>5)</b> Check Lock Switch for proper operation (do they open and close, check with ohmmeter). The Lock Motor may be powered as in above step to open and close Lock Switch. If the Lock Switch is defective, replace Motor Lock Assembly. <b>6)</b> If all above steps fail to correct situation, replace the display board and/or the relay board in the event of a motor that does not rotate. <b>7)</b> If all the above steps fail to correct the situation, replace the display board in the event of a motor that rotates endlessly.</p>

### ELECTRONIC SURFACE ELEMENT CONTROL (ESEC- some models) FAULT CODE DESCRIPTIONS

<b>E11</b>	Shorted Keypad.	Disconnect power, wait 30 seconds and reapply power. If fault returns upon power-up: <b>1.</b> Replace UIB. <b>2.</b> Replace Glass Touch Panel
<b>E13</b>	Bad EEPROM.	Replace UIB (User Interface Board).
<b>E14</b>	TST/Display tail missing	Check connection between UIB (connector J2, J3 & J4) & glass touch panel. If connections are good, replace UIB. If problem persist, replace touch panel.
<b>E15</b>	ESEC self test failed.	Replace UIB. If problem returns, replace the relay board.

# 50 Section C - Service Data

RTD SCALE		
Temp. °F	Temp. °C	Resistance (ohms)
32 ± 1.9	0.0 ± 1.1	1000 ± 4.0
75 ± 2.5	23.9 ± 1.4	1091 ± 5.3
250 ± 4.4	121.1 ± 2.4	1453 ± 8.9
350 ± 5.4	176.7 ± 3.0	1654 ± 10.8
450 ± 6.9	232.2 ± 3.8	1852 ± 13.5
550 ± 8.2	287.8 ± 4.6	2047 ± 15.8
650 ± 9.6	343.3 ± 5.3	2237 ± 18.5
900 ± 13.6	482.2 ± 7.6	2697 ± 24.4

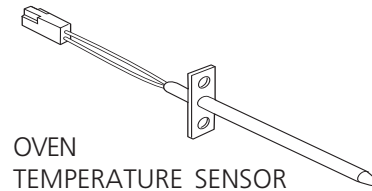

ELECTRICAL RATING			
Kw Rating 240/208 V	See Nameplate	Bake Element Wattage	2500W / 1879W
Broil Element Wattage	4000W / 3004W	Convection Element Wattage	2500W / 1879W

ELECTRIC SLIDE-IN OVEN CIRCUIT ANALYSIS MATRIX										
	On Relay Board ELEMENTS				On Convection Fan and Oven Lights Control Board		On Display Board	On Relay Board		
	Bake P9	Broil P7	Conv. P13	Door Motor J3-5	Light P2-1	Convection Fan P2-7	Door Switch P8-3 / P8-5	DLB L2 out P1	Cooling Fan Low speed J3-7	Cooling Fan High speed J3-8
Bake	X	X	X*			X*		X	X	
Keep Warm	X							X	X	
Broil		X						X		X
Conv. Bake	X	X	X			X		X	X	
Conv. Roast	X	X	X			X		X	X	
Conv. Broil		X				X		X		X
Clean	X	X						X	X	X
Locking				X						
Locked										
Unlocking				X						
Unlocked										
Light					X					
Door Open					X		X			
Door Closed										
Bread Proof	X							X	X	

■ Relay will operate in this condition only

\* Convection element and fan are used for the first rise of temperature.

## EXPLODED VIEW OF CONVECTION SYSTEM

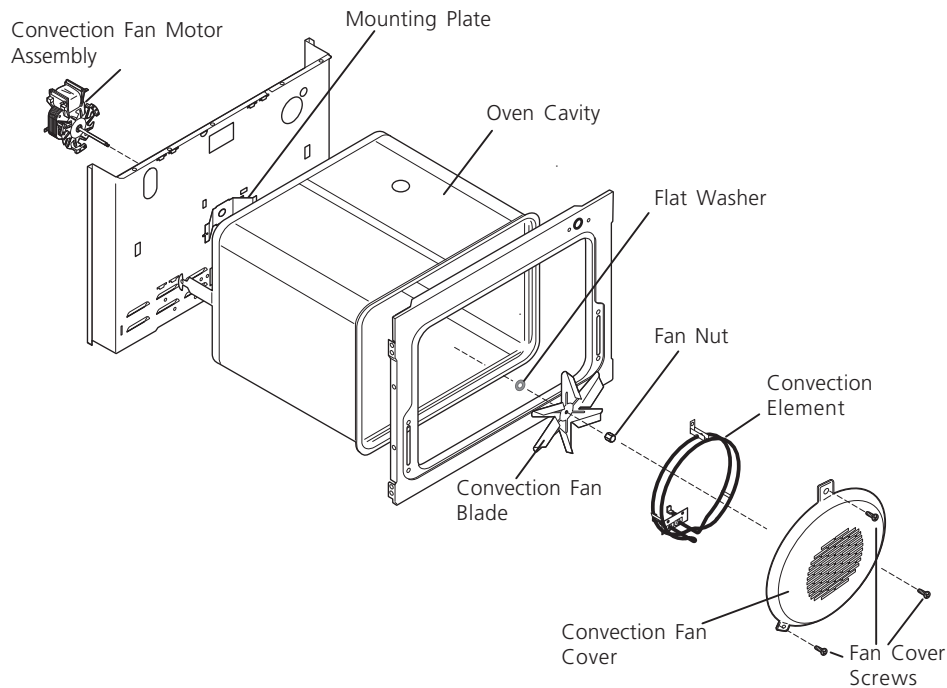

### FAN BLADE

The fan blade is mounted in the rear of the unit and has a "D" shaped mounting hole. Only minimum clearance exists between the oven back, fan blade, and fan shroud. Be careful not to bend blade when removing or installing.

Access to the fan blade is gained by removing the fan shroud, held in place by three screws, from the inside of the oven.

The fan blade is held in place with a hex nut that has left handed threads. When removing this nut, gently hold the fan blade, and turn the nut clockwise. If one of the blades becomes deformed, it may be bent back into shape using a flat surface as a reference.

A flat washer is located on the motor shaft between the snap ring on the shaft and the fan blade.

**NOTE:** If the fan blade is bent and motor vibrations increase, the noise made by the fan will be greater.

### MOUNTING PLATE OVEN

The fan motor on the rear of the unit is mounted to the main back (with three screws). There is a mounting plate held in place between the main back (with 2 screws) and the rear oven wall (with 2 screws). Should it be necessary to replace the oven cavity, you must remove the 2 screws located inside the unit at the rear of the oven cavity.

### COOLING FAN MOTOR

The 120 volt fan motor is located on the outside of the rear of the oven. The cooling fan has 2 speed options, which are driven by the oven controller. The high speed mode is used on self-clean when the temperature gets over 575F. The high speed is also used anytime the broil or convection broil function is used. The cooling fan may remain at high speed after the broil function is cancelled to allow better cooling of the oven.

# 52 Section C - Service Data

## MEAT PROBE RESISTANCE

**Meat Probe Temperature VS Resistance Table**

Temp. Celsius	Temp. Fahrenheit	Probe Resistance
25°C	77°F	49.478 Kohm +/- 7%
50°C	122°F	17.737 Kohm +/- 4.9%
80°C	176°F	6.107 Kohm +/- 3.3%
100°C	212°F	3.264 Kohm +/- 4.6%

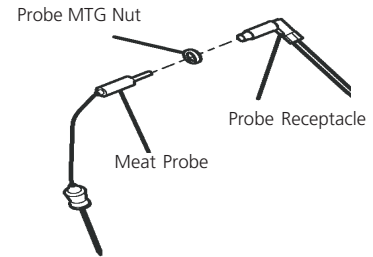

## OVEN DOOR REMOVAL AND REPLACEMENT

### To Remove and Replace Oven Door

1. Open the door to the fully opened position.
2. Pull up the lock located on each hinge support toward front of range. You may have to apply a little upward pressure on the lock to pull it up.
3. Grasp the door by the sides, pull the bottom of the door up and toward you to disengage the hinge supports.  
Keep pulling the bottom of the door toward you while rotating the top of the door toward the appliance to completely disengage the hinge levers.
4. Proceed in reverse to re-install the door. Make sure the hinge supports are fully engaged before unlocking the door

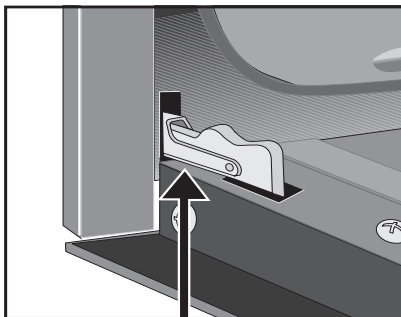

**Lock in normal position**

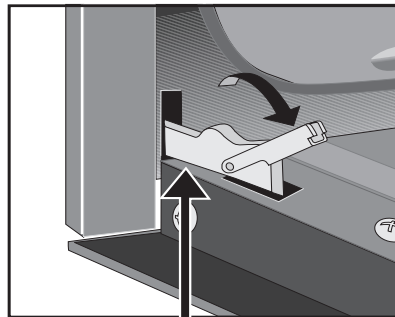

**Lock engaged for door removal**



**HINGE SLOT - Door removed from the appliance**



## TRUE HIDDEN BAKE ELEMENT REMOVAL

Follow the steps below in order to replace the through hidden bake element on a single wall oven and the lower through hidden bake element of a double wall oven.

1. Remove the lower decorative trim (2 screws).
2. Using a pair of long nose pliers, remove the cutter pins and the screw which are holding the true hidden bake element service panel in place (under the oven liner).
3. Disconnect the two bake element wires.
4. Slide the true hidden bake service panel and element out of its operational emplacement.

The steps below are to follow in order to replace a double wall oven's upper true hidden bake element only.

5. Remove the center trim. You may use a flat screwdriver in order to pull the center trim out.
6. Remove the door lock assembly.
7. Follow the same steps as for the single wall oven (2-4 above).

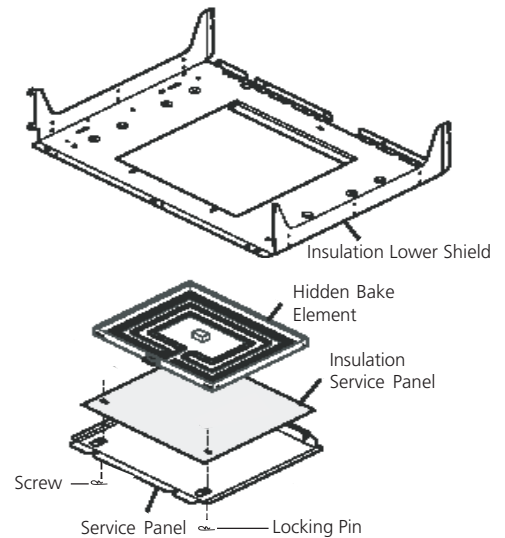

## DOOR LOCK MECHANISM

The appliance is equipped with an electronic oven control and has an auto locking door latch feature. When the self clean cycle is programmed, the door is locked by a motor operated latch system. The interior of oven doesn't need to heat up to 500°F/260°C before the door locks. However, until the temperature inside oven reaches 500°F/260°C, the self-clean program can be canceled and door will unlock immediately. After oven reaches temperatures over 500°F/260°C, the door will not unlock until temperature drops below 500°F/260°C.

If a problem appears and the door stays locked it is possible for the **servicer** to unlock the door without removing the appliance from its place. Follow the steps below:

1. Trip the circuit breaker to **OFF** position.
2. Remove the 2 screws, which are fixing the oven door latch, located between the control panel and the oven door.
3. When the screws are removed it is possible to unlock the latch with a flat screwdriver, or one of the tools supplied with the wall oven which are used to take off the oven from the cabinet. Insert the tool tip through the slot on top of the oven door. During this step it's important to take care to not damage the appliance.
4. As soon as the latch is in the unlock position, you can open the door.
5. Replace the motor latch:

Upper Oven:

1. To have access to the door latch assembly, remove the 3 screws under the control panel which are fixing it.
2. Remove the electronic plate located on the access plate.
3. Remove the access plate located on the upper air channel by removing the screw.
4. Replace the motor latch with a new one and reassemble in opposite order and manner of removal.

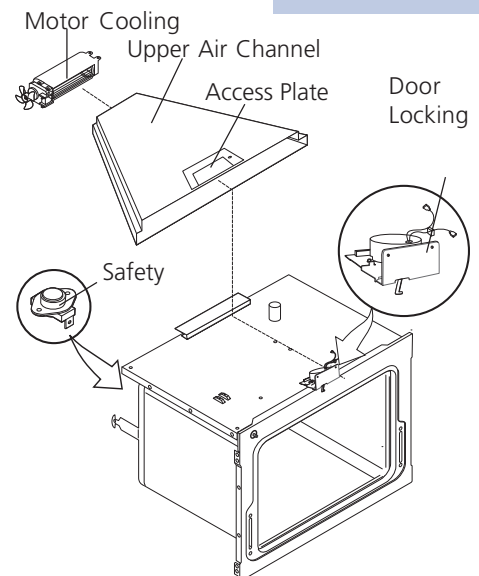

## OVEN LIGHT

This appliance is equipped with electronics that control the intensity of the oven lights. This is done with the Convection Fan and Oven Lights Control Board that modulates the AC voltage going to the 120V halogen lamps. When the light key is pressed or when the oven door is opened the display board communicates with the Convection Fan and Oven Lights Control Board to specify the required light intensity. The Convection Fan and Oven Lights Control Board also add a "theater-like" effect on the light: the light intensity is gradually ramp-up or ramp-down as the light is turned on or off.

The lights of the upper and lower oven (warmer oven) are connected together and will turn on or off at the same time, they cannot be controlled individually.

If the oven lights do not operate, check the following:

- If you are getting an F23 error code it means the display board is not able to communicate with the Convection Fan and Oven Lights Control Board, thus the oven light will not operate. Check connections between the display board and the Convection Fan and Oven Lights Control Board. Refer to the fault code section for corrective actions.
- If the lights are always ON (even with the door closed), it could be because the control mistakenly thinks the door is opened. Verify door switch and its wiring.
- Check connections on the Convection Fan and Oven Lights Control Board. On connector P2: pin 3 should be Neutral, pin 5 should be L1 (120VAC) and pin 1 should go to the oven lights. The other terminal of the light should be connected to Neutral.
- Verify if light bulbs need to be replaced.
- If there is no error code, the wiring is good and still the oven lights are not working then replace the Convection Fan and Oven Lights Control Board.

## Block Diagram and System Interconnections Slide-in electric

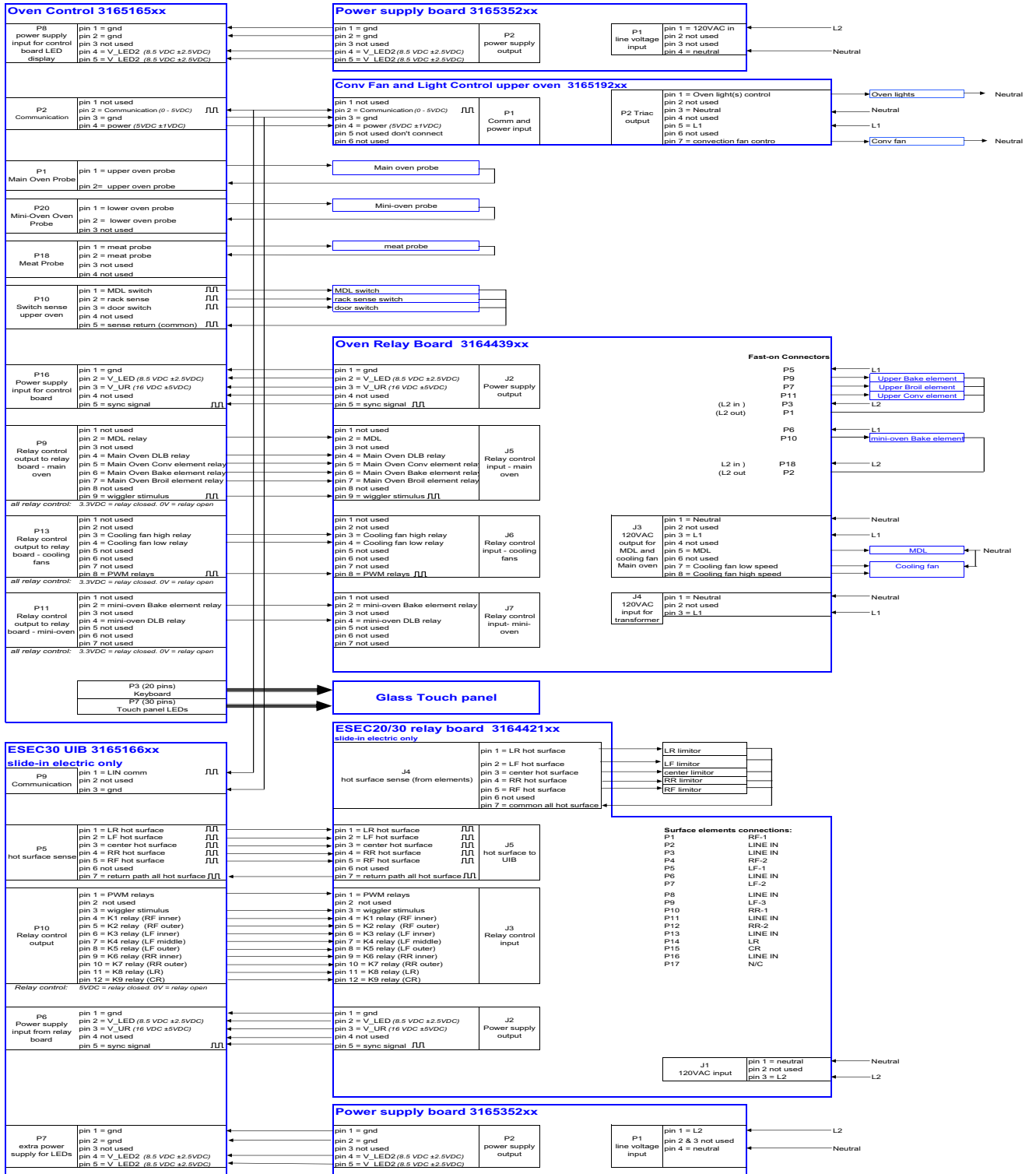

## 1.0 HOW TO ACCESS THE CONTROL PANEL AND COOKTOP AREA

ALWAYS TURN THE HOUSE BREAKER OR FUSES TO THE OFF POSITION, OR UNPLUG THE UNIT FROM THE WALL OUTLET BEFORE WORKING ON THE UNIT



**Note:** It is suggested to always remove the oven door prior to working on the unit. This will lighten the unit and prevent damaging the unit and the oven door assembly.

1.1 Fully open the oven door and locate hinge lock lever.



1.2 After locating the hinge lock lever, pull it to the lock position as shown.



1.3 Pull the oven door up at roughly 45° as shown; this will lock the oven door hinges, and pull the oven door out of its hinge receptacles and away from the unit.



1.4 Gently pull the unit out of its cutouts.

1.5 Remove the 2 screws from the decorative side panel.

**IMPORTANT:** If ever you need to replace the left hand side trim, it is imperative to remove the name plate off the trim and to glue it back on the new trim or store it in a safe place.



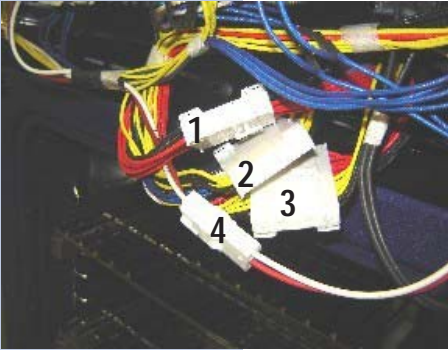

**1.10** Unplug the 4 “idiot proof” quick connections from under the control panel.



**1.11** Unplug the 2 wires from the safety thermostat located on the front of the burner box, behind the electronic oven and surface controls.

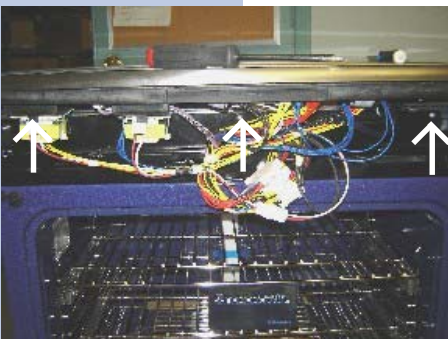

**1.12** Remove the 3 screws that hold the front of the burner box to the center trim.

**1.13** Pull the cooktop and console up (at the front) and pull it 6" toward you in order to unlock it from its 2 anchorage point at the back of the burner box.



**View of cooktop locked**



**View of cooktop unlocked**





**1.18** In order to free the cooktop element from its holder, with a screwdriver, push on the spring clip and with the other hand; push the spring clip holder away from its bracket holder.

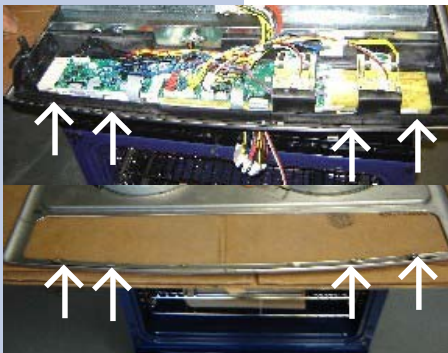

**Note:** On some models, screw 1 & 2 of the burner box of step 1.16 may be screwed from the inside. If this is the case, first unscrew the 3rd screw of step 1.16 and also unscrew the 4 screws which hold the plastic console to the front portion of the cooktop. This way, the front plastic holder will move away with the burner box.

View of the 4 screws location with and without electronics...

## 2.0 HOW TO ACCESS THE CONTROL PANEL AREA (electronic oven and surface controls)

**ALWAYS TURN THE HOUSE BREAKER OR FUSES TO THE OFF POSITION, OR UNPLUG THE UNIT FROM THE WALL OUTLET BEFORE WORKING ON THE UNIT.**

**Note:** All depending on your physical abilities, you can either work on the electronic components from under the control panel by following steps 1.1 through 1.8 or remove the cooktop and work on them standing up by following steps 1.1 through 1.115.

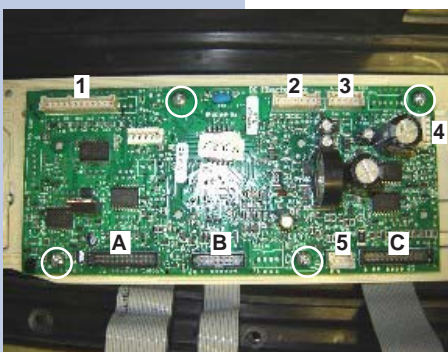

### Control panel component identification

#### *User Interface Board (UIB) for the surface elements*

**2.1** Remove 3 flex connectors (ABC).

**2.2** Remove 5 quick connectors (1 to 5).

**2.3** Remove 4 screws (circles).



## **Electronic Oven Control (Oven UIB)**

**2.1** Remove 2 flex connectors (AB).

**2.2** Remove 10 quick connectors (1 to 10).

**2.3** Remove 6 screws\* (circles).

\* There are only 5 visible screws; you will need to remove the power supply that is over the EOC (2 screws) which is over this 6th screw.

**2.4** Remove the 2 screws that hold the power supply that is over the EOC.

**2.5** Remove the hidden 6th screw that hold the EOC.

**Note:** Both power supplies have 2 screws and 2 quick connectors.

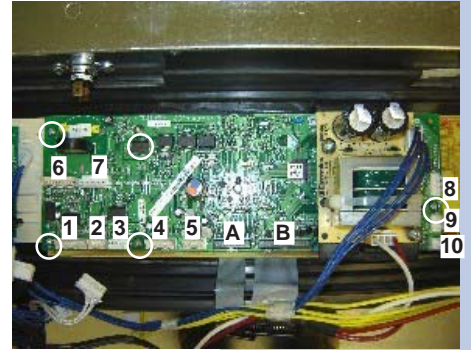

## **3.0 DOOR LOCK ASSEMBLY**

**ALWAYS TURN THE HOUSE BREAKER OR FUSES TO THE OFF POSITION, OR UNPLUG THE UNIT FROM THE WALL OUTLET BEFORE WORKING ON THE UNIT.**

### **With the oven door locked**

**3.1** Remove the right hand side screw.

**3.2** Loosen the left hand side screw and with the screwdriver still in the left hand side screw, slide the door lock assembly to the left.

### **With the oven door unlocked**

**3.3** Follow steps 1.1 through 1.12 in order to have access to the door lock assembly service panel



## 62 Section D - Replacement of parts

---

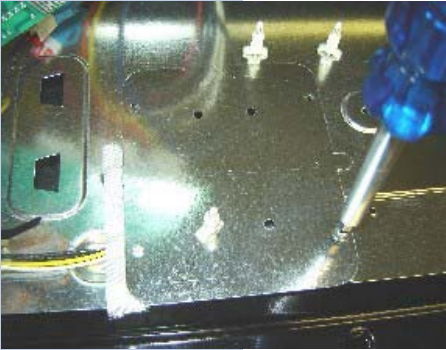

3.4 Remove the screw that holds the service panel in place.

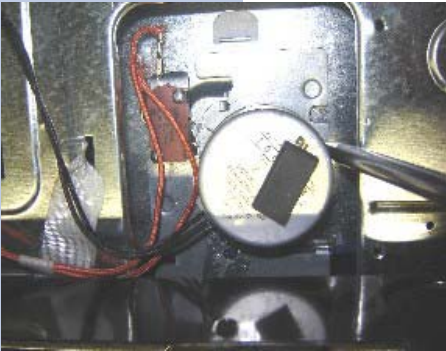

3.5 Remove the shoulder screw that holds the door lock assembly in place.



3.6 Remove the door lock assembly; unplug all wires and quick connector in order to replace the door lock assembly...

---



# 64 Section D - Replacement of parts

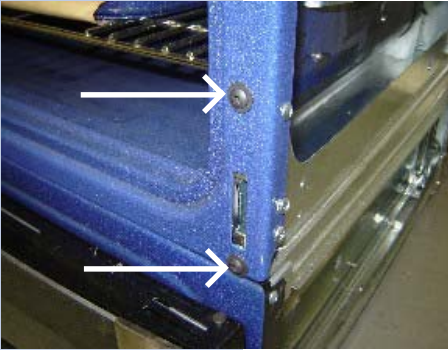

**4.10** Remove the 2 screws which hold the hinge receptacle.

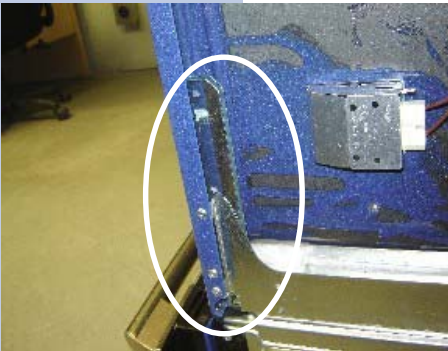

**4.11** Locate hinge receptacle from the side and remove from the back of the front frame.



**4.12** Push the insulation back into its original emplacement making sure that it's properly tucked in behind the lower panels.



**4.13** Upon replacing the side panel, make sure that it will be inserted between the frame and the upper side panel as shown.



# 66 Section D - Replacement of parts



5.41 To remove the ladder rack from the oven liner, push the ladder racks up in order to free them from their holders.



5.42 View of the ladder rack out and ready to be removed from its holder.

**Important:** Oven and ladder racks have to be removed from the oven in self-clean mode.



5.5 Gently pull on the light cover in order to have access to the halogen lamp.

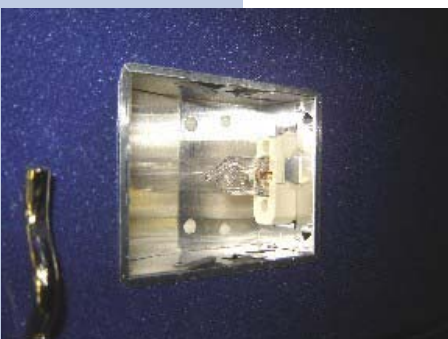

5.6 Gently pull on the halogen lamp in order to remove it from its socket.

### Important

Upon installing a new halogen lamp into its socket, the halogen lamp manufacturer suggests not to touch the lamp with your bare hands.



# 68 Section D - Replacement of parts

## 7.0 OVEN TEMPERATURE SENSOR

ALWAYS TURN THE HOUSE BREAKER OR FUSES TO THE OFF POSITION, OR UNPLUG THE UNIT FROM THE WALL OUTLET BEFORE WORKING ON THE UNIT

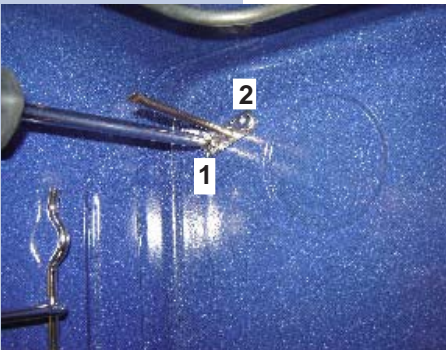

7.1 Remove the 2 screws which hold the oven temperature sensor to the oven liner.

**Note:** In order to facilitate the removal of the oven temperature sensor, you may remove the oven racks.



7.2 Gently pull the oven temperature sensor out.

**Note:** There is long enough wire in order to replace the oven temperature sensor without removing the unit from its cutouts.

## 8.0 BROIL ELEMENT

ALWAYS TURN THE HOUSE BREAKER OR FUSES TO THE OFF POSITION, OR UNPLUG THE UNIT FROM THE WALL OUTLET BEFORE WORKING ON THE UNIT



8.1 Remove the 4 screws from the broil element.

**Note:** In order to facilitate the removal of the broil element, you may remove the oven racks.



8.2 Pull the broil element out and unplug the two blue wires.

**Note:** There is long enough wire in order to service by the front without having to move the unit out of its cutouts.

**IMPORTANT:** Gently push the broil element back in place taking care not to pinch the wires between the oven cavity and the broil element.

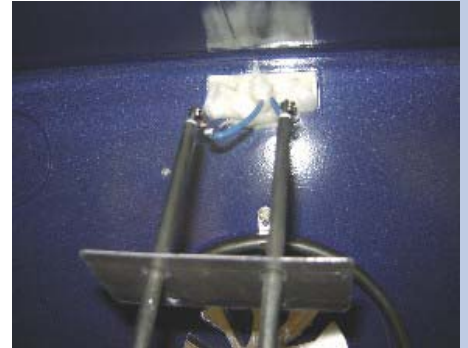

## 5.0 CONVECTION ELEMENT

**ALWAYS TURN THE HOUSE BREAKER OR FUSES TO THE OFF POSITION, OR UNPLUG THE UNIT FROM THE WALL OUTLET BEFORE WORKING ON THE UNIT.**

9.1 Remove the 3 screws that hold the convection fan cover to the back of the oven liner.

**Note:** In order to facilitate the removal of the convection fan cover, you may remove the oven racks.

9.2 Remove the 3 screws which hold the convection element to the back of the oven liner.

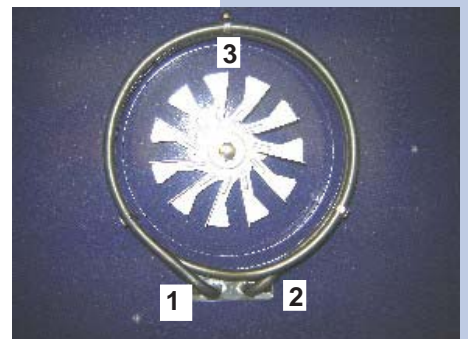
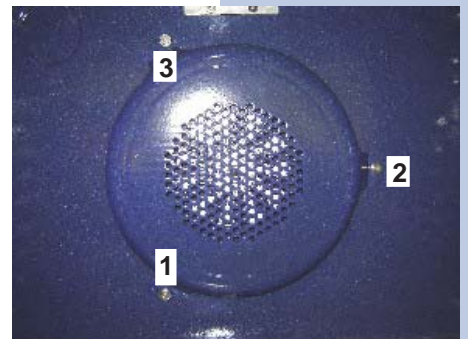

# 70 Section D - Replacement of parts



**9.3** Pull the convection element out and unplug the two orange wires.

**Note:** There is long enough wire in order to service by the front without having to move the unit out of its cutouts.

**IMPORTANT:** Gently push the convection element back in place taking care not to pinch the wires between the oven cavity and the convection element.



**9.4** Remove the convection fan cover as shown in section 9.1.

**9.5** Hold the convection fan with one hand and unscrew the nut with a pair of pliers (clockwise).



**9.6** Remove the convection fan.

**Note:** Be careful, there is a small washer on the shaft behind the fan.

**IMPORTANT:** Do not remove the 2 screws on the left and right and side of the convection motor shaft, they hold the oven liner to the back side of the unit.

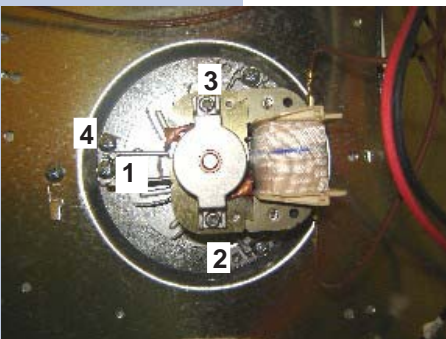

**9.7** Remove the 4 screws from the convection motor and remove from the unit.

**IMPORTANT:** The #4 screw holds the convection motor mounting plate.



# 72 Section D - Replacement of parts

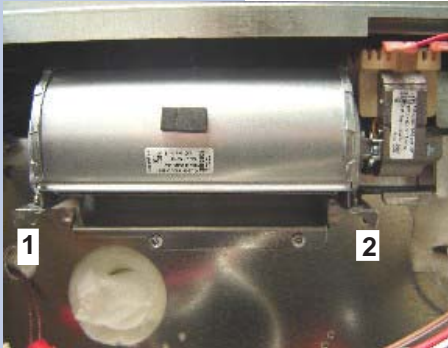

9.11 Pull the unit out and remove the back cover.

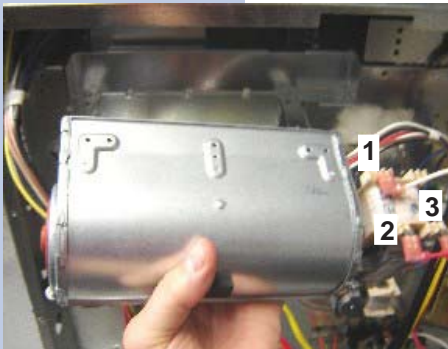

9.12 Remove the 2 screws which hold the cooling fan in place.

## 10.0 UNIT BACK VIEW AND COMPONENTS

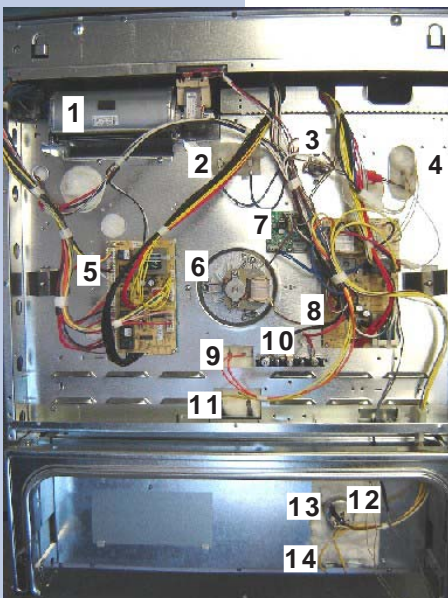

- 1 Cooling fan
- 2 Broil element
- 3 Safety thermostat
- 4 Oven temperature sensor
- 5 Cooktop relay board
- 6 Convection motor
- 7 Triac
- 8 Oven relay board
- 9 Convection element
- 10 Terminal block
- 11 Hidden bake element
- 12 Mini oven temperature sensor
- 13 Mini oven light socket
- 14 Mini oven element



# 74 Section D - Replacement of parts

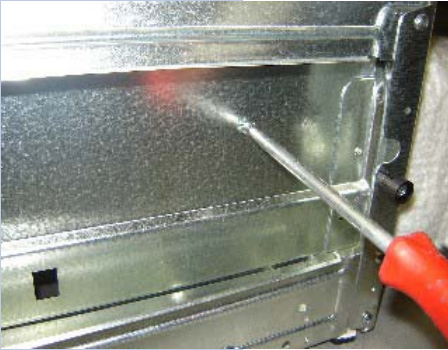

**11.5** Remove the 2 screws (one on each side) of the lower back side of the mini oven.

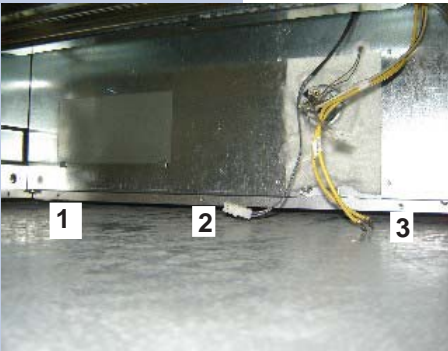

**11.6** Remove the 3 screws from under the back panel of the mini oven.



**11.7** Remove the wires from the mini oven sensor, mini oven light and mini oven element.



**11.8** Insert these wired between the upper and lower frame as shown.



# 76 Section D - Replacement of parts



**11.14** After having removed these 3 screws, the hidden bake element will lower itself as shown.

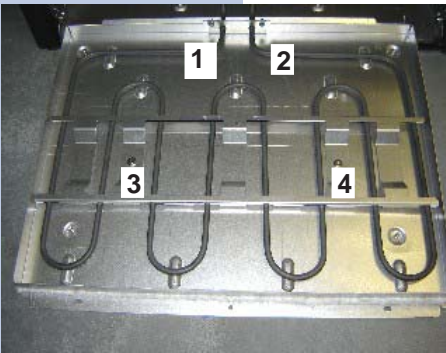

**11 15** Remove the four screws that hold the hidden bake element to its service panel.

## 12.0 MINI OVEN Light AND GLIDES

**ALWAYS TURN THE HOUSE BREAKER OR FUSES TO THE OFF POSITION, OR UNPLUG THE UNIT FROM THE WALL OUTLET BEFORE WORKING ON THE UNIT.**



**12.1** Remove the mini oven drawer as shown in section 11.1.

**12.2** Locate the spring clip holder, move it either to the left or right hand side, remove the light cover and replace the light bulb.





# 78 Section D - Replacement of parts



**13.3** Remove the 6 screws from the upper trim, turn the mini oven door and also remove the 6 ones from the lower trim.

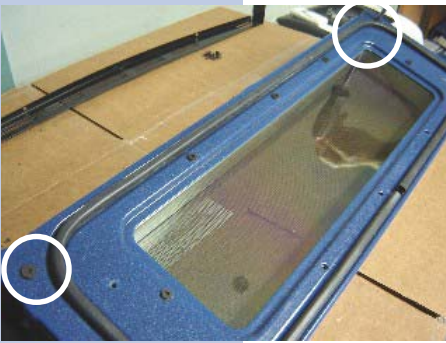

**13.4** Remove the 2 screws which hold the mini oven door handle.



**13.5** Pull the mini oven door apart.

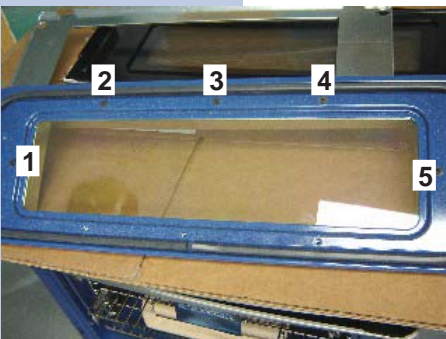

**13.6** Remove the 5 screws that hold the inner mini oven door liner to the inner glass frame assembly.



# 80 Section D - Replacement of parts



**14.3** Remove the center screw of the lower trim; the one closest from the oven door glass.



**14.4** Remove the 10 screws that hold the front decorative glass assembly; 4 at the top and 3 on each of the left and right hand side.

**Important:** Upon installing the decorative glass assembly back on the door, remember that the smallest screw goes on the lower left and ring hand side through the side and lower trim as well as into the hinge assembly.

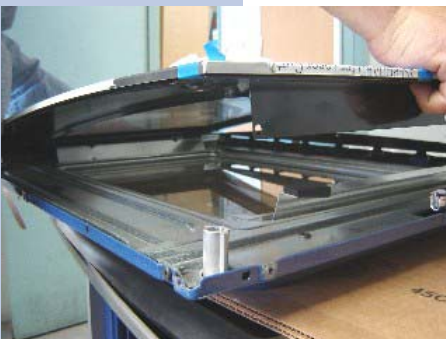

**14.5** Pull the decorative glass assembly off of the oven door.

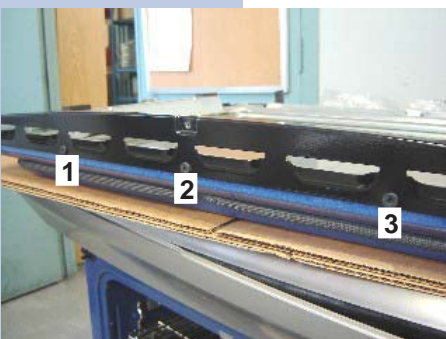

**14.6** Remove the 3 screws that hold the lower trim.



## 82 Section D - Replacement of parts

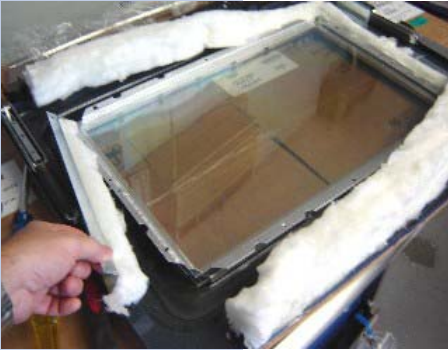

14.11 Remove the glass holders and insulation.

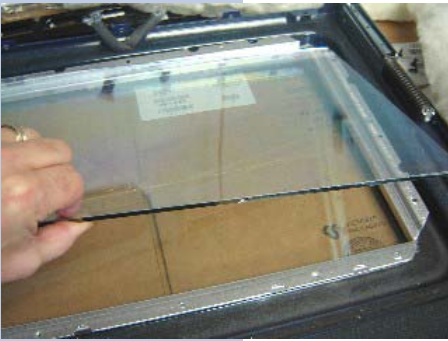

14.12 Remove the 2<sup>nd</sup> inner glass from the glass pack assembly.



14.13 Remove the inner glass pack frame.



14.14 Remove the first inner door glass.

14.15 In order to remove the oven door gasket, refer to section 13.8 Refer to section 13.9 in order to properly install the oven door handle screw spacer.



 **Electrolux**

