

Technical Service Manual

Over The Range Microwave Oven



Models
E130SM55JB
E130SM55JS
E130SM55JW

 **Electrolux**

Safe Servicing Practices

Avoid personal injury and/or property damage by observing important Safe Servicing Practices.

Following are some limited examples of safe practices:

1. DO NOT attempt a product repair if you have any doubts as to your ability to complete the repair in a safe and satisfactory manner.
2. Always Use The Correct Replacement Parts as indicated in the parts documentation. Substitutions may defeat compliance with Safety Standards Set For Home Appliances. Do not exceed maximum recommended wattage on light bulb replacements. Doing so could blow fuses and/or damage transformers.
3. Before servicing or moving an appliance:
 - Remove power cord from the electrical outlet, trip circuit breaker to the OFF position, or remove fuse.
4. Never interfere with the proper operation of any safety device.
5. Use ONLY REPLACEMENT PARTS CATALOGED FOR THIS APPLIANCE. Substitutions may defeat compliance with Safety Standards Set For Home Appliances.
6. GROUNDING: The standard color coding for safety ground wires is GREEN, or GREEN with YELLOW STRIPES. Ground leads are not to be used as current carrying conductors. It is EXTREMELY important that the service technician reestablish all safety grounds prior to completion of service. Failure to do so will create a hazard.
7. Prior to returning the product to service, ensure that:
 - All electrical connections are correct and secure.
 - All electrical leads are properly dressed and secured away from sharp edges, high-temperature components, and moving parts.
 - All non-insulated electrical terminals, connectors, heaters, etc. are adequately spaced away from all metal parts and panels.
 - All safety grounds (both internal and external) are correctly and securely connected.
 - All panels are properly and securely reassembled.

© 2010 Electrolux Home Products, Inc.

Basic Information

This Manual has been prepared to provide Electrolux Service Personnel with Operation and Service Information for Electrolux Microwave Oven EI30SM55JB, EI30SM55JS and EI30SM55JW.

Table of Contents

Section 1 Basic Information

Safe Servicing Practices.....	1-1
Table of Contents	1-2
Warnings and Safety Information	1-3
Precautions To Be Observed Before And During Servicing To Avoid Possible Exposure To Excessive Microwave Energy	1-4
Before Servicing	1-4
Danger High Voltage	1-4
Before Servicing	1-5
When Testing Is Completed	1-5
Microwave Measurement Procedure USA	1-6
Microwave Measurement Procedure Canada	1-7
Product Specification.....	1-8
Grounding Instructions	1-9
Discharging Capacitor	1-9
Oven Diagram	1-10
Special Instructions for the Turntable Support and Turntable Glass Tray.....	1-11

Section 2 Operation

Operating Sequence Description.....	2-1
Off Condition.....	2-1
Cooking Condition	2-1
Variable Cooking	2-3
Power Output Reduction	2-3
Cook Top Lamp	2-3
Ventilation Methods	2-3
Sensor Cooking Condition.....	2-4
Cooking Sequence	2-4
Component Descriptions	2-5
Door Open Mechanism	2-5
Door Sensing Switch, Secondary Interlock Switch.....	2-5
Monitor Switch.....	2-5
Thermal Cut-Out (Cavity)	2-6
Turntable Motor.....	2-6
Cooling Fan Motor.....	2-6
Hood Fan Motor	2-6
Thermostat (60°C On).....	2-6
Thermostat (70°C Off).....	2-6
Antenna Motor.....	2-6
Hood Lamp.....	2-6
Touch Control Panel Assembly	2-7
Humidity Sensor Circuit.....	2-8

Section 3 Troubleshooting and Error Codes

Warnings and Cautions	3-1
Troubleshooting Guide Chart	3-2
Test Procedures	3-3

Section 4 Component Teardown and Testing

Warnings and Cautions	4-1
Removal Of Oven From Wall.....	4-2
Hood Louver Removal.....	4-2
Outer Case Removal.....	4-2
Power Transformer Removal.....	4-3
Positive Lock® Connector (No-Case Type) Removal	4-3
Hood Fan Motor, Hood Duct, Oven Lamp Socket And AH Sensor Removal.....	4-4
Magnetron Removal	4-5
High Voltage Rectifier And High Voltage Capacitor Removal.....	4-5
Hood Fan Thermostat (60°C ON and 70°C OFF) Removal	4-6
Cooling Fan Motor Removal.....	4-6
Turntable Motor Removal.....	4-7
Antenna Motor Removal.....	4-8
Oven Lamp Removal.....	4-8
Stirrer Cover And Stirrer Fan Installation.....	4-8
Servicing For Touch Control Panel.....	4-8
Panel Sub Assembly And Control Unit Removal.....	4-10
Door Sensing Switch / Secondary Interlock Switch And Monitor Switch Removal	4-10
Door Sensing Switch / Secondary Interlock Switch And Monitor Switch Adjustment.....	4-11
Door Replacement.....	4-12
Door Disassembly	4-13
Cook Top Lamp Socket Removal.....	4-13

Section 5 Wire Diagrams

Circuit Components	5-1
Glass Touch Key Unit Diagram	5-2
Control Unit Circuit	5-3
Oven Wiring Schematic Off Condition	5-4

Section 6 Parts List

Parts List.....	6-1
Parts List.....	6-2
Oven And Cabinet Parts Exploded View	6-3
Door Assembly and Control Unit	6-4
Packing And Accessories	6-5

WARNING

CERTAIN INITIAL PARTS ARE INTENTIONALLY NOT GROUNDED AND PRESENT A RISK OF ELECTRICAL SHOCK ONLY DURING SERVICING. SERVICE PERSONNEL - DO NOT CONTACT THE FOLLOWING PARTS WHILE THE APPLIANCE IS ENERGIZED:

INVERTER UNIT, THAT INCLUDES HIGH VOLTAGE CAPACITOR, HIGH VOLTAGE POWER TRANSFORMER, HIGH VOLTAGE RECTIFIER, HEAT SINK, ETC., AND MAGNETRON, HIGH VOLTAGE HARNESS ETC.; IF PROVIDED, FAN ASSEMBLY, COOLING FAN MOTOR.

ALL THE PARTS MARKED “*” ON PARTS LIST ARE USED AT VOLTAGES MORE THAN 250V.

REMOVAL OF THE OUTER WRAPPER GIVES ACCESS TO VOLTAGE ABOVE 250V.

ALL THE PARTS MARKED “Δ” ON PARTS LIST MAY CAUSE UNDUE MICROWAVE EXPOSURE, BY THEMSELVES, OR WHEN THEY ARE DAMAGED, LOOSENED OR REMOVED.

WARNING

THIS SERVICE MANUAL IS INTENDED FOR USE BY PERSONS HAVING ELECTRICAL AND MECHANICAL TRAINING AND A LEVEL OF KNOWLEDGE OF THESE SUBJECTS GENERALLY CONSIDERED ACCEPTABLE IN THE APPLIANCE REPAIR TRADE. ELECTROLUX HOME PRODUCTS CANNOT BE RESPONSIBLE, NOR ASSUME ANY LIABILITY, FOR INJURY OR DAMAGE OF ANY KIND ARISING FROM THE USE OF THIS MANUAL.

WARNING

NEVER OPERATE THE OVEN UNTIL THE FOLLOWING POINTS ARE ENSURED.

- (A) THE DOOR IS TIGHTLY CLOSED.
- (B) THE DOOR BRACKETS AND HINGES ARE NOT DEFECTIVE.
- (C) THE DOOR PACKING IS NOT DAMAGED.
- (D) THE DOOR IS NOT DEFORMED OR WARPED.
- (E) THERE IS NO OTHER VISIBLE DAMAGE WITH THE OVEN.

SERVICING AND REPAIR WORK MUST BE CARRIED OUT ONLY BY TRAINED SERVICE PERSONNEL. SERVICEMEN SHOULD REMOVE THEIR WATCHES WHENEVER WORKING CLOSE TO OR REPLACING THE MAGNETRON.

CAUTION

All repairs should be done in accordance with the procedures described in this manual. This product complies with Federal Performance Standard 21 CFR Subchapter J(DHHS).

Never defeat any of the B+ voltage interlocks. Do not apply AC power to the unit (or any of its assemblies) unless all solid-state heat sinks are correctly installed.

Some semiconductor (“solid state”) devices are easily damaged by static electricity. Such components are called Electrostatically Sensitive Devices (ESDs). Examples include integrated circuits and field-effect transistors.

Immediately before handling any semiconductor components or assemblies, drain the electrostatic charge from your body by touching a known earth ground.

Basic Information

Precautions To Be Observed Before And During Servicing To Avoid Possible Exposure To Excessive Microwave Energy

- (a) Do not operate or allow the oven to be operated with the door open.
- (b) Make the following safety checks on all ovens to be serviced before activating the magnetron or other microwave source, and make repairs as necessary: (1) interlock operation, (2) proper door closing, (3) seal and sealing surfaces (arcing, wear, and other damage), (4) damage to or loosening of hinges and latches, (5) evidence of dropping or abuse.
- (c) Before turning on microwave power for any service test or inspection within the microwave generating compartments, check the magnetron, wave guide or transmission line, and cavity for proper alignment, integrity, and connections.
- (d) Any defective or misadjusted components in the interlock, monitor, door seal, and microwave generation and transmission systems shall be repaired, replaced, or adjusted by procedures described in this manual before the oven is released to the owner.
- (e) A microwave leakage check to verify compliance with the Federal Performance Standard should be performed on each oven prior to release to the owner.

Before Servicing

Before servicing an operative unit, perform a microwave emission check as per the Microwave Measurement Procedure outlined in this service manual.

If microwave emissions level is in excess of the specified limit, contact ELECTROLUX HOME PRODUCTS, INC. immediately.

If the unit operates with the door open, service person should:

- 1) Tell the user not to operate the oven.
- 2) Contact Electrolux HOME PRODUCTS, INC. and Food and Drug Administration's Center for Devices and Radiological Health immediately.

Service personnel should inform ELECTROLUX HOME PRODUCTS, INC. of any certified unit found with emissions in excess of $4\text{mW}/\text{cm}^2$. The owner of the unit should be instructed not to use the unit until the oven has been brought into compliance.

Danger High Voltage

Do not energize a microwave oven with the outer case cabinet removed, because a microwave oven generates high voltage in the circuit.

If you intend to operate the oven employing the high frequency switching power converter circuit, you should take special precautions to avoid an electrical shock hazard.

The high voltage transformer, high voltage capacitor and high voltage diode have energized high voltage potential of approximately 8KV.

The aluminium heat sink is connected to the switching power transistor collector pole, and has an energized high voltage potential of approximately 650V peak.

DO NOT ACCESS THE HIGH VOLTAGE TRANSFORMER, HIGH VOLTAGE CAPACITOR, HIGH VOLTAGE DIODE AND HEAT SINK WHEN THE POWER SUPPLY IS CONNECTED TO AN ELECTRICAL OUTLET.

WARNING

MICROWAVE OVENS CONTAIN CIRCUITRY CAPABLE OF PRODUCING VERY HIGH VOLTAGE AND CURRENT. CONTACT WITH THE FOLLOWING PARTS MAY RESULT IN A SEVERE, POSSIBLY FATAL, ELECTRICAL SHOCK.

INVERTER UNIT, THAT INCLUDES HIGH VOLTAGE CAPACITOR, HIGH VOLTAGE POWER TRANSFORMER, HIGH VOLTAGE RECTIFIER, HEAT SINK ETC., AND MAGNETRON, HIGH VOLTAGE HARNESS ETC.. READ THE SERVICE MANUAL CAREFULLY AND FOLLOW ALL INSTRUCTIONS.



Before Servicing

1. Disconnect the power supply cord, and then remove outer case.
2. Open the door and block it open.
3. Discharge high voltage capacitor.

CAUTION

To discharge the high voltage capacitor, wait for 60 seconds and then short-circuit the connection of the high-voltage capacitor (that is the connecting lead of the high-voltage rectifier) against the chassis with the use of an insulated screwdriver.

Whenever troubleshooting is performed, the power supply must be disconnected. In some cases it may be necessary to connect the power supply after the outer case has been removed, in this event:

1. Disconnect the oven power supply cord and then remove the outer case.
2. Open the door and block it open.
3. Discharge high voltage capacitor.
4. Disconnect leads to the primary of the inverter unit.
5. Ensure that these leads remain isolated from other components and oven chassis by using insulation tape.
6. After that procedure, reconnect the power supply cord.

When Testing Is Completed

1. Disconnect the power supply cord, and then remove outer case.
2. Open the door and block it open.
3. Discharge high voltage capacitor.

CAUTION

To discharge the high voltage capacitor, wait for 60 seconds and then short-circuit the connection of the high-voltage capacitor (that is the connecting lead of the high-voltage rectifier) against the chassis with the use of an insulated screwdriver.

4. Reconnect leads to the primary of the inverter unit.
5. Reinstall the outer case (cabinet).
6. Reconnect the power supply cord after the outer case is installed.
7. Run the oven and check all functions.

After repairing

1. Reconnect all leads removed from components during testing.
2. Reinstall the outer case (cabinet).
3. Reconnect the power supply cord after the outer case is installed.
4. Run the oven and check all functions.
Microwave ovens should not be run empty. To test for the presence of microwave energy within a cavity, place a cup of cold water on the oven turntable, close the door and set the power to HIGH and then set the microwave timer for two (2) minutes. When the two minutes has elapsed (timer at zero) carefully check that the water is now hot. If the water remains cold carry out Before Servicing procedure and re-examine the connections to the component being tested.

Basic Information

Microwave Measurement Procedure (USA)

A. Requirements:

- 1) Microwave leakage limit (Power density limit): The power density of microwave radiation emitted by a microwave oven should not exceed 1 mW/cm^2 at any point 5 cm or more from the external surface of the oven, measured prior to acquisition by a purchaser, and thereafter (through the useful life of the oven), 5 mW/cm^2 at any point 5 cm or more from the external surface of the oven.
- 2) Safety interlock switches: Primary interlock switch shall prevent microwave radiation emission in excess of the requirement as above mentioned, secondary interlock switch shall prevent microwave radiation emission in excess of 5 mW/cm^2 at any point 5 cm or more from the external surface of the oven.

B. Preparation for testing:

Before beginning the actual measurement of leakage, proceed as follows:

- 1) Make sure that the actual instrument is operating normally as specified in its instruction booklet.
Important:
Survey instruments that comply with the requirement for instrumentation as prescribed by the performance standard for microwave ovens, 21 CFR 1030.10(c)(3)(i), must be used for testing.
- 2) Place the oven tray in the oven cavity.
- 3) Place the load of $275 \pm 15 \text{ ml}$ (9.8 oz) of tap water initially at $20 \pm 5^\circ\text{C}$ ($68 \pm 9^\circ\text{F}$) in the center of the oven cavity. The water container shall be a low form of 600 ml (20 oz) beaker with an inside diameter of approx. 8.5 cm (3-1/2 in.) and made of an electrically nonconductive material such as glass or plastic. The placing of this standard load in the oven is important not only to protect the oven, but also to insure that any leakage is measured accurately.
- 4) Set the cooking control on Full Power Cooking Mode.
- 5) Close the door and select a cook cycle of several minutes. If the water begins to boil before the survey is completed, replace it with 275 ml of cool water.

C. Leakage test:

Closed-door leakage test (microwave measurement)

- 1) Grasp the probe of the survey instrument and hold it perpendicular to the gap between the door and the body of the oven.
- 2) Move the probe slowly, not faster than 1 in./sec. (2.5 cm/sec.) along the gap, watching for the maximum indication on the meter.
- 3) Check for leakage at the door screen, sheet metal seams and other accessible positions where the continuity of the metal has been breached (eg., around the switches, indicator, and vents). While testing for leakage around the door pull the door away from the front of the oven as far as is permitted by the closed latch assembly.
- 4) Measure carefully at the point of highest leakage and make sure that the highest leakage is no greater than 4 mW/cm^2 , and that the primary interlock switch and secondary interlock switch do turn the oven OFF before any door movement.

NOTE: After servicing, record data on service invoice and microwave leakage report.

Microwave Measurement Procedure (Canada)

After adjustment of the door switches are completed individually or collectively, switch test and microwave leakage test must be performed with survey instrument and test result must be confirmed to meet the requirement of the performance standard for microwave ovens as under mentioned.

A. Requirements:

Every microwave oven shall function in such a manner that when the oven is fully assembled and operating with its service controls and user controls adjusted to yield the maximum output, the leakage radiation, at all points at least 5 cm. from the external surface of the oven, does not exceed:

- 1) 1.0 mW/cm² with the test load of 275 ± 15 ml of water at an initial temperature 20 ± 5°C.
- 2) 5.0 mW/cm² when the outer enclosure is removed with a test load of 275 ± 15 ml of water at an initial temperature 20 ± 5°C.
- 3) 5.0 mW/cm² without a test load.

B. Preparation for testing:

Before beginning the actual measurement of leakage, proceed as follows:

- 1) Make sure that the actual instrument is operating normally as specified in its instruction booklet. Survey instruments that comply with the requirement for instrumentation as prescribed by CSA and NHW performance standard for microwave ovens must be used for testing recommended instruments are, NARDA 8100 and NARDA 8200.
- 2) Place the oven tray in the oven cavity.
- 3) Place the load of 275 ± 15 ml (9.8 oz) of tap water initially at 20 ± 5°C (68 ± 9°F) in the center of oven cavity. The water container shall be a low form of a 600 ml (20 oz) beaker with an inside diameter of approx. 8.5 cm (3-1/2 in.) and made of an electrically nonconductive material such as glass or plastic. The placing of this standard load in the oven is important not only to protect the oven, but also to insure that any leakage is measured accurately.
- 4) Set the cooking control on Full Power Cooking Mode.
- 5) Close the door and select a cook cycle of several minutes. If the water begins to boil before the survey is completed, replace it with 275 ml of cool water.

C. Leakage test with enclosure installed:

- 1) Grasp probe of survey instrument and hold it perpendicular to gap between door and the body of the oven.
- 2) Move the probe slowly, not faster than 2.5 cm/sec. along the gap, watching for maximum indication on meter.
- 3) Check for leakage at the door screen, sheet metal seams and other accessible positions where the continuity of the metal has been breached (eg., around the switches, indicator, and vents). While testing for leakage around door, pull door away from the front of the oven as far as is permitted by the closed latch assembly.
- 4) Measure carefully at the point of highest leakage and make sure that the highest leakage is no greater than 4 mW/cm², and that the primary interlock switch and secondary interlock switch do turn the oven OFF before any door movement.

D. Leakage test without enclosure:

- 1) Remove the enclosure (cabinet).
- 2) Grasp the probe of the survey instrument and hold it perpendicular to all mechanical and electric parts of the oven that is accessible to the user of the oven including, but not limited to, the waveguide, cavity seams, magnetron gap between the door and the body of the oven.
- 3) Move probe slowly, not faster than 2.5 cm/sec. along the gap, watching for the maximum indication on meter.
- 4) Measure carefully at the point of highest leakage and make sure that the highest leakage is under 5 mW/cm².

CAUTION: Special attention should be given to avoid electrical shock because HIGH VOLTAGE is generated during this test.

E. No Load test

- 1) Operate the oven without a load and measure the leakage by the same method as the above test procedure "Leakage test with enclosure installed"
- 2) Make sure that the highest leakage should not exceed 5 mW/cm².

NOTE: After servicing, record data on service invoice and microwave leakage report.

Basic Information

Product Specification

Item	Description
Power Requirements	(USA)120 Volts / 14.3 Amperes 60 Hertz Single phase, 3 wire grounded
Power Output	1000 watts (IEC 705 Test Procedure) Operating frequency of 2450MHz
Outside Case Dimensions	Width 29-15/16" Height 16-1/16" Depth 18-15/32"
Cooking Cavity Dimensions 2.0 Cubic Feet	Width 22-1/2" Height 10-1/16" Depth 14-31/32" Tray Size 15-7/8
Lighting- Hood Lamp	40W x 1 Krypton light bulb
Lighting- Oven Cavity Light	40W x 1 Krypton light bulb
Weight	Approximately 58 lbs.
Control Complement	<p>Touch Control System Clock (1:00 - 12:59) Timer (0 - 99 min. 99 seconds) Microwave Power for Variable Cooking Repetition Rate; P-HI Full power throughout the cooking time P-90 approx. 90% of Full Power P-80 approx. 80% of Full Power P-70 approx. 70% of Full Power P-60 approx. 60% of Full Power P-50 approx. 50% of Full Power P-40 approx. 40% of Full Power P-30 approx. 30% of Full Power P-20 approx. 20% of Full Power P-10 approx. 10% of Full Power P-0 No power throughout the cooking time</p> <p>Timer on-off pad, Set clock pad, User Pref pad, Sensor Cook pad Sensor Reheat pad, Popcorn pad, Baked Potato pad, Fresh veggies pad Frozen veggies pad, Auto cook pad, Auto defrost pad, Auto reheat pad Snacks pad, Keep warm pad, Melt, soften pad, Power level pad Turn table on-off pad, Number pads, (Quick start pads), START/add 30sec pad, STOP/Clear pad, Light pad, Fan pad</p>
Safety Standard	UL Listed FCC Authorized DHHS Rules, CFR, Title 21, Chapter 1, Subchapter J

Grounding Instructions

This oven is equipped with a three prong grounding plug. It must be plugged into a wall receptacle that is properly installed and grounded in accordance with the National Electrical Code, local codes and ordinances. In the event of an electrical short circuit, grounding reduces the risk of electric shock by providing an escape wire for the electric current.

WARNING

IMPROPER USE OF THE GROUNDING PLUG CAN RESULT IN A RISK OF ELECTRIC SHOCK.

Electrical Requirements

The oven is equipped with a 3-prong grounding plug. **DO NOT UNDER ANY CIRCUMSTANCES CUT OR REMOVE THE GROUNDING PIN FROM THE PLUG.** The power supply cord and plug must be connected to a separate 120 Volt AC, 60 Hz, 15 Amp. or more dedicated line, using a grounded receptacle. The receptacle should be located inside the cabinet directly above the Microwave Oven/Hood system mounting location.

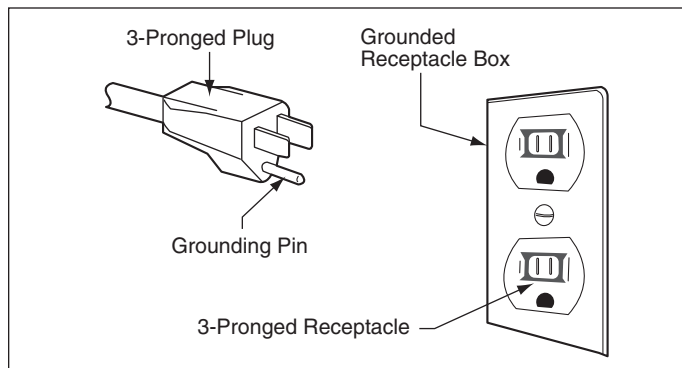

Figure 1-1. Electrical Connection

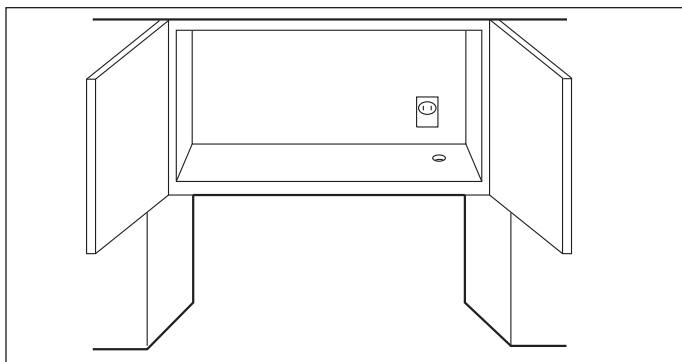

Figure 1-2. Electrical Connection In Cabinet

Discharging Capacitor

1. High Voltage Warning!

Do not attempt to measure any of the high voltages, this includes the filament voltage of the magnetron. High voltage is present during any cook cycle. Before touching any components or wiring, always unplug the oven and discharge the high voltage capacitor (See Figure 1-3).

2. The high-voltage capacitor remains charged about 60 seconds after disconnection. Short the negative terminal of the high-voltage capacitor to the oven chassis. (Use an insulated screwdriver.)
3. High voltage is maintained within specified limits by close-tolerance, safety-related components and adjustments. If the high voltage exceeds the specified limits, check each of the special components.

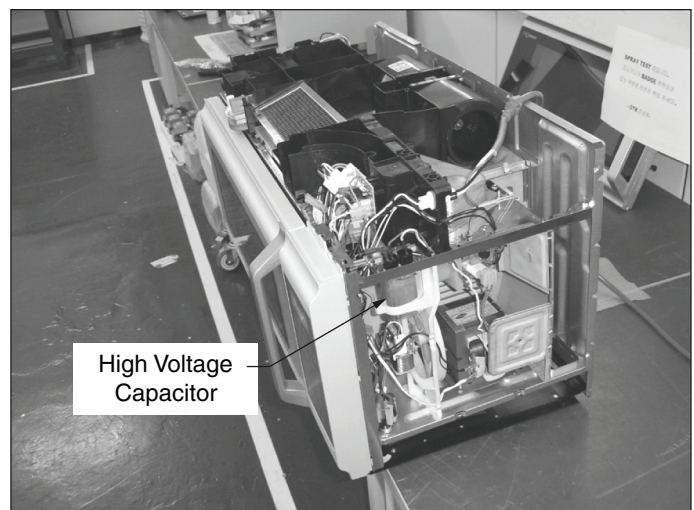

Figure 1-3. Capacitor Discharging
NOTE: The illustration above gives a generalized location of the high voltage capacitor. Refer to the exploded view of the oven and cabinet for exact location.

Basic Information

Oven Diagram

Components

1. Microwave oven door with see-through window.
2. Door hinges.
3. Waveguide cover: DO NOT REMOVE.
4. Turntable motor shaft.
5. Microwave oven light. It will light when microwave oven is operating or door is open.
6. Rack holders.
7. Safety door latches. The microwave oven will not operate unless the door is securely closed.
8. Handle.
9. Light pad. Touch the light pad once for high, twice for medium, three times for low and four times to turn off the light.
10. Fan pad. Touch the fan pad once for high speed, twice for medium speed, three times for low speed and four times to turn off the fan.
11. Auto-Touch control panel.
12. Time display: Digital display, 99 minutes, 99 seconds
13. Ventilation openings.
14. Removable turntable. The turntable will rotate clockwise or counterclockwise. Only remove for cleaning.
15. Removable turntable support. First, carefully place the turntable support in the motor shaft in the center of the microwave oven floor. Then, place the turntable on the turntable support securely.
16. Rack for 2-level cooking/ reheating.
17. Light cover.
18. Grease filters.
19. Menu label.
20. Rating label (model and serial number).

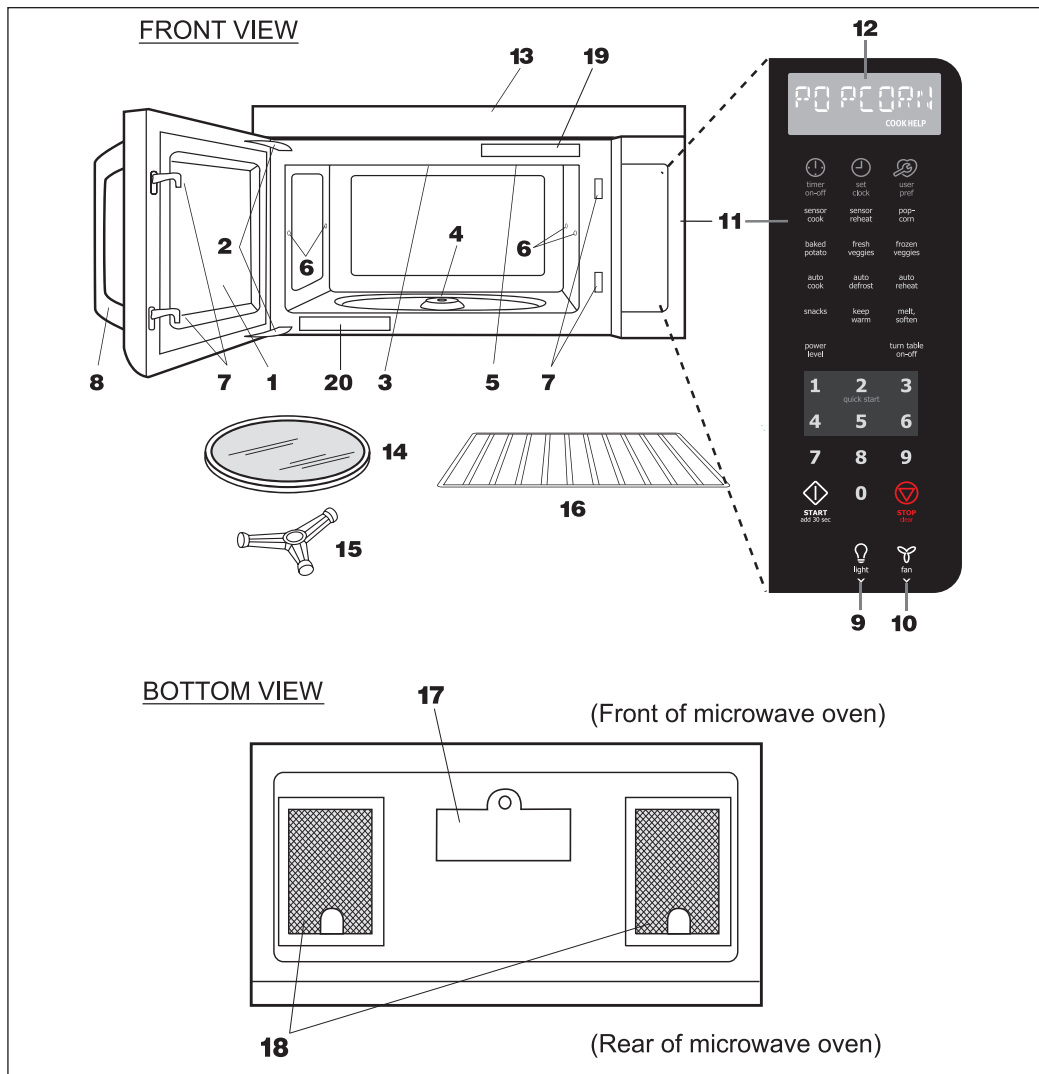

Figure 1-4. Oven Overview

Special Instructions for the Turntable Support and Turntable Glass Tray

⚠ CAUTION

Make sure to remove the tape at the turntable support before operation. Because the tape is attached when the product is shipped from the factory.

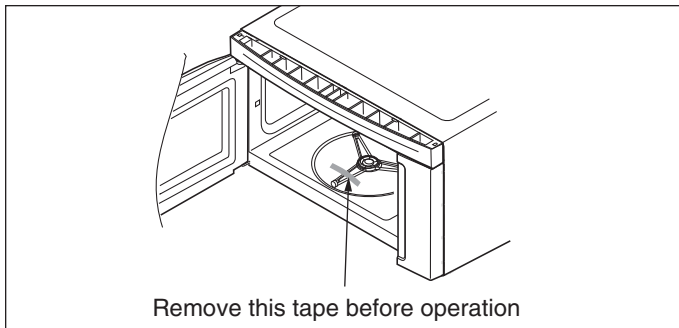

Figure 1-5. Turntable Support Installation

Read carefully before installing the turntable glass tray and turntable support for proper operation. Improper installation will cause dragging noise and erratic turntable glass rotation.

1. Place the turntable support to the turntable motor shaft (Inside oven bottom plate hole). And make sure the center of turntable support is inserted to turntable motor shaft.
2. The turntable glass tray should be set so all three rollers of the turntable support contact to the flat surface of the turntable glass tray.

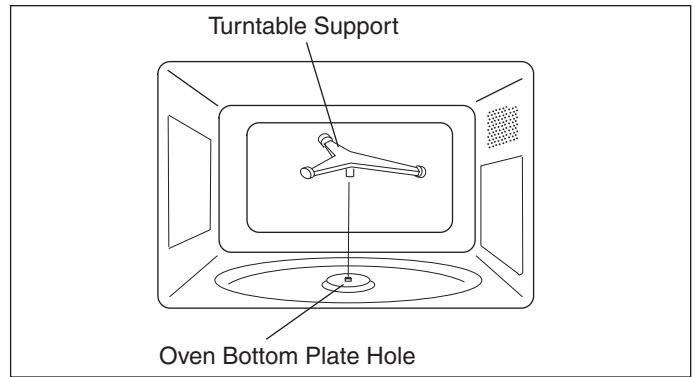

Figure 1-5a.

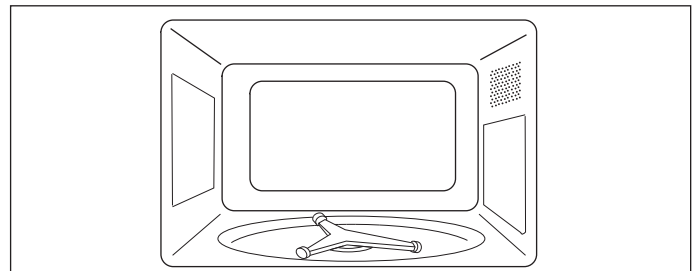

Figure 1-5b.

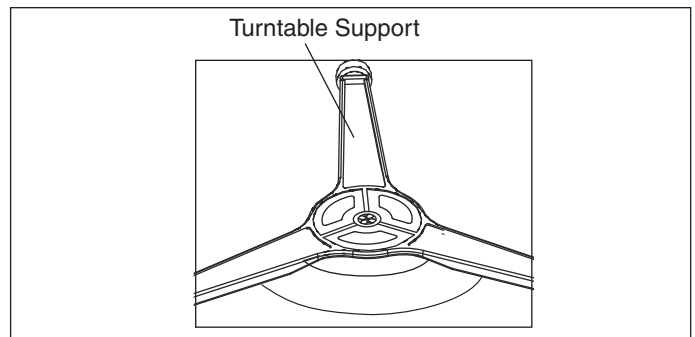

Figure 1-5c.

	CORRECT	WRONG
Back View	<p>Flat Surface of Turntable Glass Tray</p> <p>Roller of Turntable Support</p>	<p>Flat Surface of Turntable Glass Tray</p> <p>Out of Flat Surface</p>
Side View	<p>Flat Surface of Turntable Glass Tray</p> <p>Roller of Turntable Support</p>	<p>Flat Surface of Turntable Glass Tray</p> <p>Out of Flat Surface</p>

Operating Sequence Description

The following is a description of component functions during oven operation.

OFF CONDITION

Closing the door activates the door sensing switch and secondary interlock switch. (In this condition, the monitor switch contacts are opened.)

When oven is plugged in, 120 volts A.C. is supplied to the control unit. (See Figure 2-1).

1. The display will show "ENJOY YOUR OVEN, PRESS CLEAR AND TOUCH CLOCK".
To set any program or set the clock, you must first touch the STOP/CLEAR pad. The display will clear, and " : " appears.

COOKING CONDITION

Program desired cooking time by touching the NUMBER pads. Program the power level by touching the POWER LEVEL pad and then a Number pad.

When the START pad is touched, the following operations occur:

1. The contacts of relays are closed and components connected to the relays are turned on as follows.
(For details, refer to Figure 2-2)

RELAY CONNECTED COMPONENTS

RY-1	Oven Lamp / Fan Motor / Fan Motor
------	-----------------------------------

RY-2	Power Transformer
------	-------------------

RY-7	Turntable Motor
------	-----------------

2. 120 volts AC is supplied to the primary winding of the power transformer and is converted to about 3.3 volts AC output on the filament winding, and approximately 2000 volts AC on the high voltage winding.
3. The filament winding voltage heats the magnetron filament and the H.V. winding voltage is sent to a voltage doubler circuit.
4. The microwave energy produced by the magnetron is channeled through the waveguide into the cavity feedbox, and then into the cavity where the food is placed to be cooked.
5. Upon completion of the cooking time, the power transformer, oven lamp, etc. are turned off, and the generation of microwave energy is stopped. The oven will revert to the OFF condition.

6. When the door is opened during a cook cycle, monitor switch, door sensing switch, secondary interlock switch, and primary interlock relay are activated with the following results. The circuits to the antenna motor, the cooling fan motor, the turntable motor, and the high voltage components are de-energized, and the digital read-out displays the time still remaining in the cook cycle when the door was opened.
7. The monitor switch is electrically monitoring the operation of the secondary interlock switch and door sensing switch is mechanically associated with the door so that it will function in the following sequence.
 - (1) When the door opens from a closed position, the primary interlock relay, door sensing switch and secondary interlock switch open their contacts, and then the monitor switch contacts close.
 - (2) When the door is closed from the open position, the monitor switch contacts open first. Then the contacts of the secondary interlock switch and door sensing switch close, and contacts of the relay (RY1) open.

If the secondary interlock switch and primary interlock relay (RY2) fail with the contacts closed when the door is opened, the closing of the monitor switch contacts will form a short circuit through the monitor fuse, secondary interlock switch, relay (RY1) and primary interlock relay (RY2), causing the monitor fuse to blow.

Operation

SCHEMATIC

Note: Condition Of Oven

1. Door Closed.
2. Clock Appears On Display

NOTES:

1. Circuits subject to change without notice
2. The neutral wire(White or Gray wire) must be connected to the prescribed tab terminal of the lamp socket.
3. Only certain models use the humidity sensor.
4. The neutral wire(White/Gray wire) must be connected to the winding start tab terminal of the power transformer primary winding.

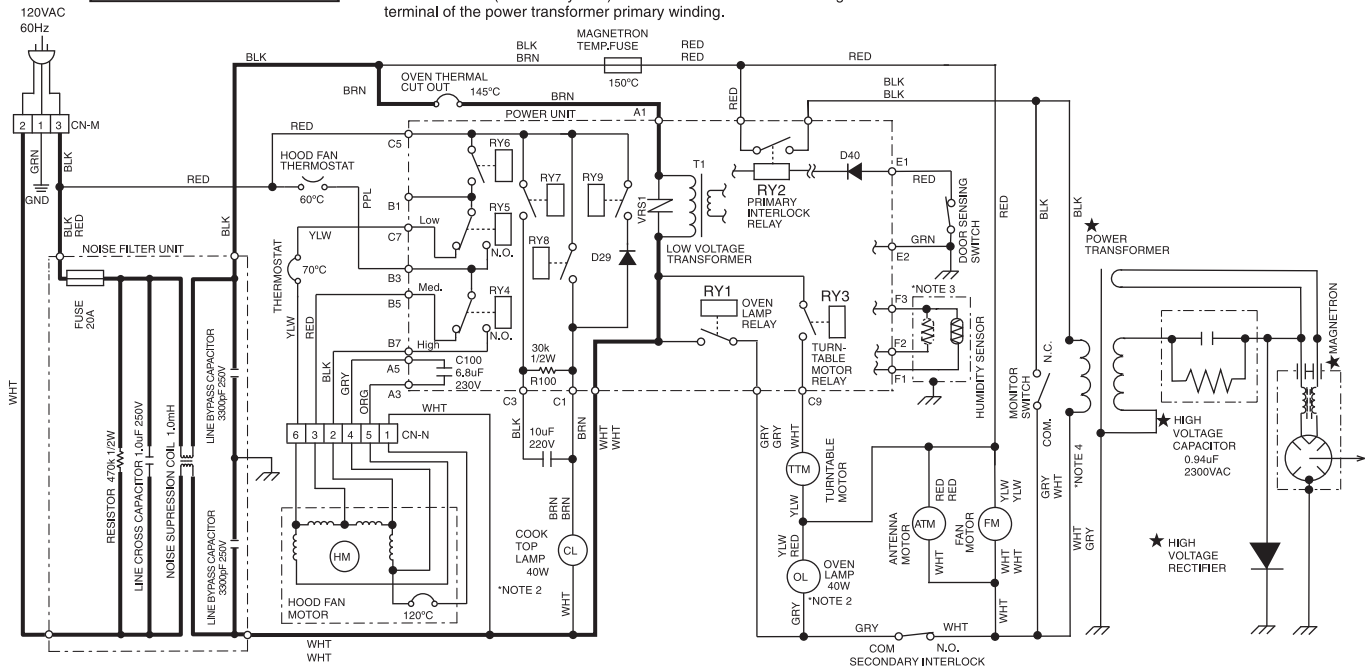

NOTE: "★" indicates components with potentials above 250V

Figure 2-1. Microwave Oven Off Condition

SCHEMATIC

Note: Condition Of Oven

1. Door Closed.
2. Cooking Time Programmed.
3. Variable Cooking Control "100%".
4. Start Pad Touched.

NOTES:

1. Circuits subject to change without notice
2. The neutral wire(White or Gray wire) must be connected to the prescribed tab terminal of the lamp socket.
3. Only certain models use the humidity sensor.
4. The neutral wire(White/Gray wire) must be connected to the winding start tab terminal of the power transformer primary winding.

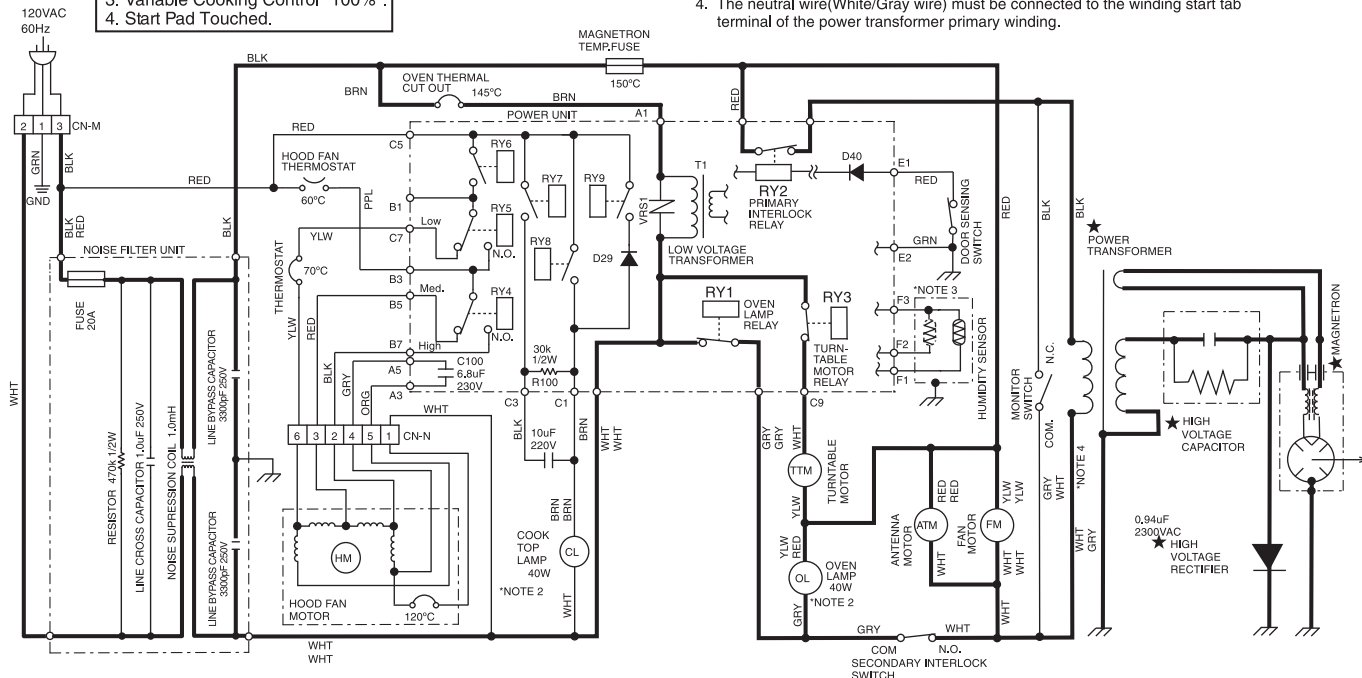

Figure 2-2. Oven Schematic-Microwave Oven Cooking Condition

Variable Cooking

When Variable Cooking Power is programmed, the 120 volts A.C. is supplied to the power transformer intermittently through the contacts of relay (RY-2) which is operated by the control unit within a 32 second time base. Microwave power operation is as follows:

Vari-Mode	ON TIME	OFF TIME
Power 10 (High) (100% Power)	32 sec.	0 sec.
Power 9 (P-90) (Approx. 90%)	30 sec.	2 sec.
Power 8 (P-80) (Approx. 80%)	26 sec.	6 sec.
Power 7 (P-70) (Approx. 70%)	24 sec.	8 sec.
Power 6 (P-60) (Approx. 60%)	22 sec.	10 sec.
Power 5 (P-50) (Approx. 50%)	18 sec.	14 sec.
Power 4 (P-40) (Approx. 40%)	16 sec.	16 sec.
Power 3 (P-30) (Approx. 30%)	12 sec.	20 sec.
Power 2 (P-20) (Approx. 20%)	8 sec.	24 sec.
Power 1 (P-10) (Approx. 10%)	6 sec.	26 sec.
Power 0 (P-0) (0% power)	0 sec.	32 sec.

NOTE

The ON/OFF time ratio does not correspond with the percentage of microwave power, because approx. 2 seconds are needed for heating of the magnetron filament.

Power Output Reduction

If the oven is set for over 40 minutes at 80%, 90% or 100% power level, after the first 40 minutes the power level will automatically adjust itself to 70% power to avoid overcooking.

Cook Top Lamp

The brightness of the cook top lamp is controlled by the relays RY7, RY8 and RY9 as shown in the following table.

Brightness	RY7	RY9	RY8
High	OFF	OFF	ON
Mid.	ON	ON	OFF
Low	OFF	ON	OFF

Ventilation Methods

1. VERTICAL VENTING

For this venting method, hot air rising from the conventional range below is drawn in by the hood fan motor through the grease filters at the right and left sides of the base cover, up through the right and left sides of the oven cavity, then discharged vertically at rear center top of the oven, into the customer's vent system.

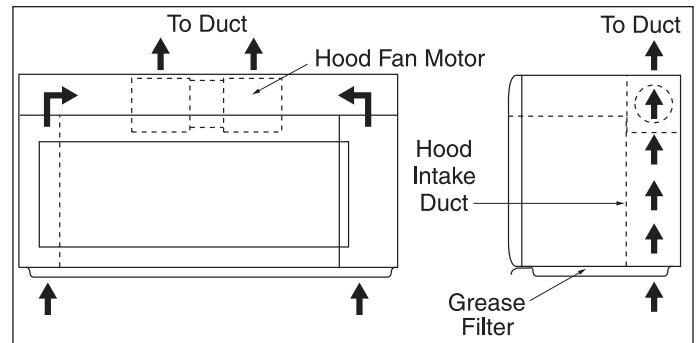

2. HORIZONTAL VENTING

The air handling is the same as VERTICAL VENTING except that the final air discharge is directed horizontally out from the top rear of the oven into the customer's vent system.

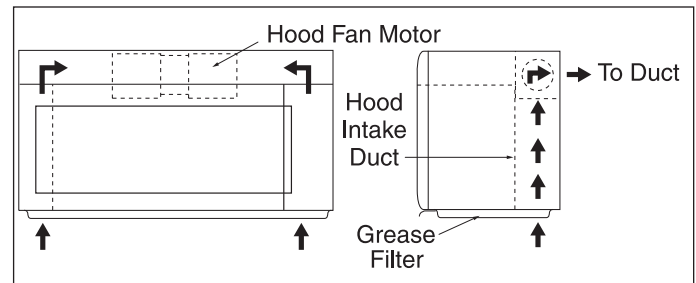

3. RE-CIRCULATION (INSIDE VENTING)

The air handling is the same as VERTICAL VENTING except that the final air discharge is directed horizontally through the upper front of the oven into the kitchen.

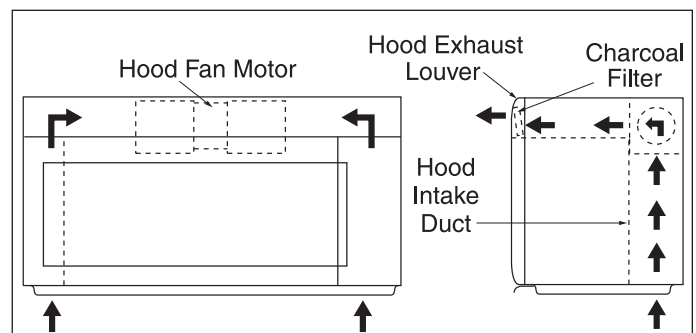

Operation

Sensor Cooking Condition

Using the SENSOR COOK function, the foods are cooked without figuring time, power level or quantity. When the oven senses enough steam from the food, it relays the information to its microprocessor which will calculate the remaining cooking time and power level needed for best results.

When food is cooked, water vapor is developed. The sensor “senses” the vapor and its resistance increases gradually. When resistance reaches the value set according to the menu, supplementary cooking is started. The time of supplementary cooking is determined by experiment with each food category and inputted into the LSI.

An example of how the sensor works:
(BAKED POTATOES)

1. Potatoes at room temperature. Vapor is emitted very slowly.



2. Heat Potatoes. Moisture and humidity is emitted rapidly. You can smell the aroma as it cooks.

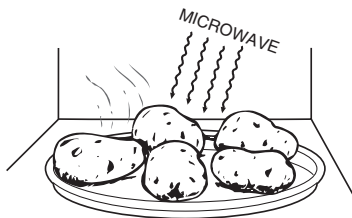

3. Sensor detects moisture and humidity and calculates cooking time and variable power.

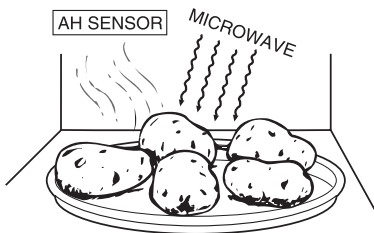

Cooking Sequence

1. Operate the oven in sensor cooking mode by referring to the operation manual.

NOTE

The oven should not be operated on Sensor Cooking immediately after plugging in the unit. Wait two minutes before cooking on Sensor Cooking.

2. The coil of shut-off relays (RY1 and RY3) are energized, the oven lamp, turntable motor and cooling fan motor are turned on, but the power transformer is not turned on.
3. After about 32 seconds, the relay (RY2) is energized. The power transformer is turned on, microwave energy is produced and first stage is started. The 32 seconds is the cooling time required to remove any vapor from the oven cavity and sensor.

NOTE

During this first stage, do not open the door or touch Clear Off pad.

4. When the sensor detects the vapor emitted from the food, the display switches over to the remaining cooking time and the timer counts down to zero. At this time, the door may be opened to stir food, turn it or season, etc.
5. When the timer reaches zero, an audible signal sounds. The shut-off relay (RY1 and RY3) and relay (RY2) are generalized and the power transformer, oven lamp, etc. are turned off.
6. Opening the door or touching the STOP CLEAR pad, the time of day will reappear on the display and the oven will revert to an OFF condition.

Component Descriptions

DOOR OPEN MECHANISM

The door is opened by pulling the door handle down and forward, referring to Figure 2-6. When the door handle is pulled down, the latch heads are moved upward. When the door handle is pulled forward, the latch heads are released from the latch hooks right and left. Now, the door will open.

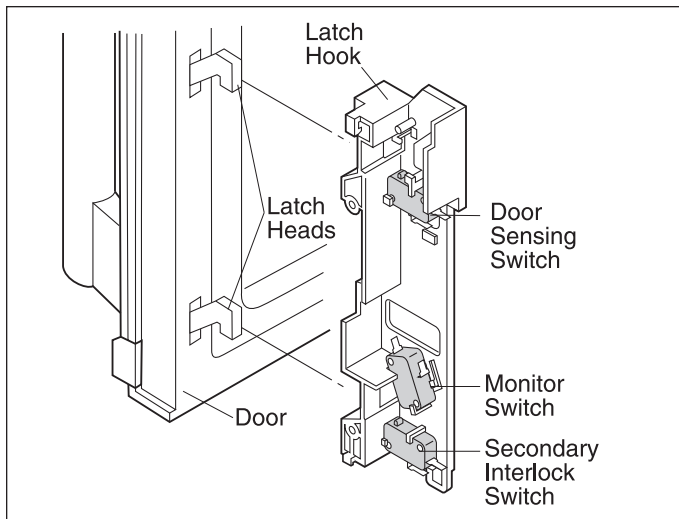

Figure 2-6.

DOOR SENSING SWITCH, SECONDARY INTERLOCK SWITCH

The secondary interlock switch is mounted in the lower position of the latch hook. The door sensing switch in the primary interlock system is mounted in the upper position of the latch hook. The switches are activated by the latch heads on the door. When the door is opened, the switches interrupt the circuit to all components. A cook cycle cannot take place until the door is firmly closed, thereby activating both interlock switches. The primary interlock system consists of the door sensing switch and primary interlock relay located on the control circuit board.

MONITOR SWITCH

The monitor switch is activated (the contacts opened) by the latch head on the door while the door is closed. The switch is intended to render the oven inoperative, by means of blowing the monitor fuse, when the contacts of the primary interlock relay (RY2) and secondary interlock switch fail to open when the door is opened.

Functions:

1. When the door is opened, the monitor switch contact close (to the ON condition) due to their being normally closed. At this time, the primary interlock relay (RY2), and secondary interlock switch are in the OFF condition (contacts open) due to their being normally open contact switches. The contacts of relay (RY1) are in the ON condition (contacts close).
2. As the door goes to a closed position, the monitor switch contacts are first opened and then the door sensing switch and the secondary interlock switch contacts close. (On opening the door, each of these switches operate inversely.)
3. If the door is opened, and the primary interlock relay (RY2) and secondary interlock switch contacts fail to open, the monitor fuse blows simultaneously with closing of the monitor switch contacts.

⚠ CAUTION

Before replacing a blown monitor fuse test the door sensing switch, primary interlock relay (RY2), relay (RY1), secondary interlock switch and monitor switch for proper operation.

🗨 NOTE

Monitor fuse and switch are replaced as an assembly.

THERMAL CUT-OUT (CAVITY)

This thermal cut-out is located on the top of the oven cavity. It is designed to prevent damage to the oven unit if the food in the oven catches fire due to overheating produced by improper setting of cooking time or failure of control unit. Under normal operation, the thermal cut-out remains closed. However, the thermal cut-out will open at 293°F (145°C) causing the oven to shut down.

Operation

TURNTABLE MOTOR

The turntable motor rotates the turntable located on the bottom of the oven cavity, so that the foods on the turntable cook evenly during cooking. Turntable will turn in either direction. The turntable motor can be turned off by touching TURNTABLE ON/OFF pad.

COOLING FAN MOTOR

The cooling fan motor drives a blade which draws external cool air. This cool air is directed through the air vanes surrounding the magnetron and cools the magnetron. This air is channelled through the oven cavity to remove steam and vapors given off from the heating foods. It is then exhausted through the exhausting air vents at the oven cavity.

HOOD FAN MOTOR

The hood fan motor is a three-speed, single-phase, double pole induction type, requiring a hood fan capacitor. It is located outside the upper rear part of the oven cavity, is to remove, from around the oven, hot air rising from the conventional electric or gas range over which it is installed. This air is then expelled either vertically or horizontally through the customer supplied duct system, or discharged back into the kitchen. The automatic operation is medium speed. The manual operation is a three speed (Low/ Mid/ High).

THERMOSTAT (60°C ON)

This thermostat is located on the right base plate. It is designed to automatically turn on the hood fan motor whenever the hot air rising from the conventional range below causes the temperature at the thermostat to rise to 140°F (60°C) or higher, thus removing this hot air from around microwave oven. When the temperature around the thermostat drops to 113°F (45°C) or lower, the thermostat shuts off the hood fan motor.

THERMOSTAT (70°C OFF)

This thermostat is located on the right base plate. It is designed to automatically cut off power to the hood fan low speed terminal whenever the hot air rising from the conventional range below causes the temperature at the thermostat to rise to 158°F (70°C) or higher, thus removing this hot air from around microwave oven. When the temperature around the thermostat drops to 131°F (55°C) or lower, the thermostat supplies power to the hood fan low speed terminal.

ANTENNA MOTOR

The antenna motor drives the stirrer antenna to stir the microwave radiation from the waveguide.

HOOD LAMP

The hood lamps are mounted at the hood lamp angle on the base cover. Touch the Light pad once for high, twice for medium, three times for low and four times to turn off the light.

Touch Control Panel Assembly

OUTLINE OF TOUCH CONTROL PANEL

The touch control section consists of the following units.

- (1) Glass touch key
- (2) Control Unit

The principal functions of these units and the signals communicated among them are explained below.

Glass Touch Key Unit

The glass touch key unit is composed of a matrix, signals generated in the LSI are sent to the glass touch key unit. When a key pad is touched, a signal is completed through the glass touch key unit and passed back to the LSI to perform the function that was requested.

1. IC3
This is the IC to judge the selected key.

Control Unit

Control unit consists of LSI, IC, reset circuit, indicator circuit, power source circuit, relay circuit, buzzer circuit, synchronizing signal circuit, glass touch key unit circuit and humidity sensor circuit.

1. IC1 (LSI):
This is a microcomputer, responsible for controlling the entire control unit.
2. IC2:
This is the IC to amplify the signal from the humidity sensor.
3. Reset Circuit:
This circuit generates a signal which resets the LSI (IC1) to the initial state when power is supplied.
4. Indicator Circuit:
Indicator element is Fluorescent Display. Basically, a Fluorescent Display is triode having a cathode, a grid and an anode. Usually, the cathode of a Fluorescent Display is directly heated and the filament serves as cathode. The Fluorescent Display has 8-digits, 16-segments are used for displaying figures.
5. Power Source Circuit:
This circuit generates voltages necessary in the control unit from the AC line voltage. In addition, the synchronizing signal is available in order to compose a basic standard time in the clock circuit.

Symbol	Voltage	Application
VC	+5V	LSI(IC1)

6. Relay Circuit:
A circuit to drive the magnetron, fan motor, stirrer motor, hood motor and light the oven lamp and cook top lamp.
7. Buzzer Circuit:
The buzzer is responsive to signals from the LSI to emit audible sounds (key touch sound and completion sound).
8. Synchronizing Signal Circuit:
The power source synchronizing signal is available in order to compose a basic standard time in the clock circuit. It accompanies a very small error because it works on commercial frequency.
9. Door Sensing Switch:
A switch to "tell" the LSI if the door is open or closed.
10. Humidity Sensor Circuit:
This circuit detects moisture of the cooking food to allow its automatic cooking.

Operation

Humidity Sensor Circuit

(1) Structure of Humidity Sensor:

The humidity sensor includes two thermistors as shown in the illustration. One thermistor is housed in the closed vessel filled with dry air while another in the open vessel. Each sensor is provided with the protective cover made of metal mesh to be protected from the external airflow.

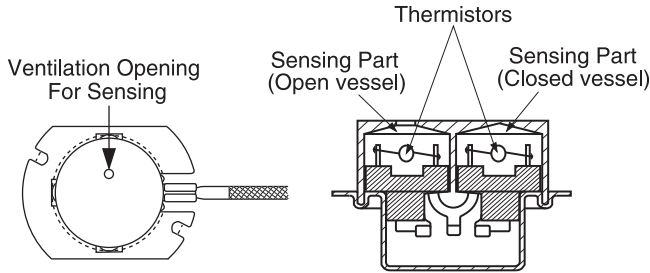

(2) Operational Principle of Humidity Sensor:

The figure below shows the basic structure of an absolute humidity sensor. A bridge circuit is formed by two thermistors and two resistors (R91 and R96). The output of the bridge circuit is to be amplified by the operational amplifier.

Each thermistor is supplied with a current to keep it heated at about 150°C (302°F), the resultant heat is dissipated in the air and if the two thermistors are placed in different humidity conditions they show different degrees of heat conductivity leading to a potential difference between them causing an output voltage from the bridge circuit, the intensity of which is increased as the absolute humidity of the air increases. Since the output is very minute, it is amplified by the operational amplifier.

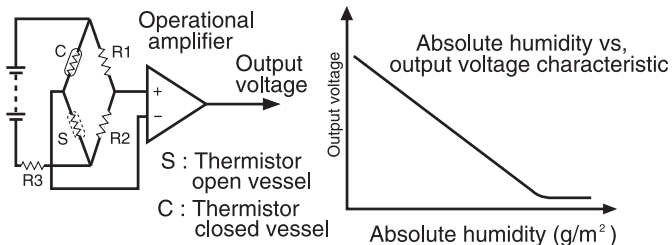

(3) Detector Circuit of Humidity Sensor Circuit:

This detector circuit is used to detect the output voltage of the absolute humidity circuit to allow the LSI to control sensor cooking of the unit. When the unit is set in the sensor cooking mode, 16 seconds clearing cycle occurs then the detector circuit starts to function and the LSI observes the initial voltage available at its AN1 terminal.

With this voltage given, the switches SW1 to SW5 in the LSI are turned on in such a way as to change the resistance values in parallel with R98 ~ R102.

Changing the resistance values results in that there is the same potential at both F-3 terminal of the absolute humidity sensor and AIN6 terminal of the LSI. The voltage of AIN6 terminal will indicate about -2.5V. This initial balancing is set up about 16 seconds after the unit is put in the Sensor Cooking mode. As the sensor cooking proceeds, the food is heated to generate moisture by which the resistance balance of the bridge circuit is deviated to increase the voltage available at AIN5 terminal of the LSI.

Then the LSI observes that voltage at AIN5 terminal and compares it with its initial value, and when the comparison rate reaches the preset value (fixed for each menu to be cooked), the LSI causes the unit to stop sensor cooking; thereafter, the unit goes in the next operation automatically.

When the LSI starts to detect the initial voltage at AIN5 terminal 16 seconds after the unit has been put in the Sensor Cooking mode, if it is not possible to balance the bridge circuit due to disconnection of the absolute humidity sensor, ERROR will appear on the display and the cooking is stopped.

(4) Humidity sensor circuit:

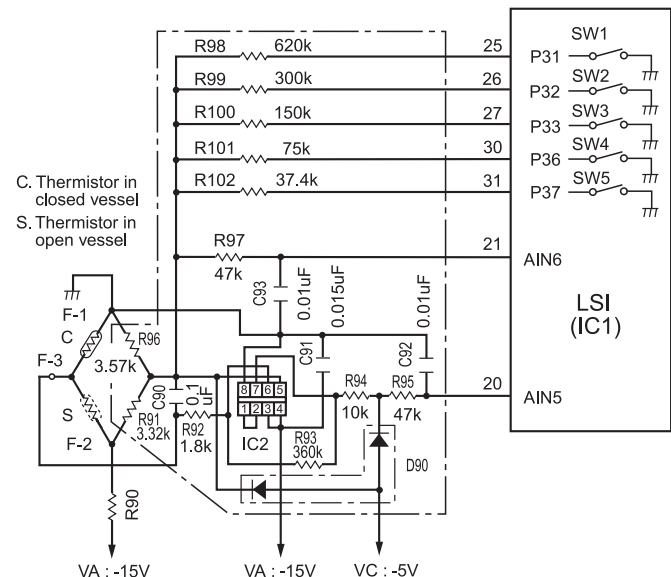

Troubleshooting Guide

When troubleshooting the microwave oven, it is helpful to follow the Sequence of Operation in performing the checks. Many of the possible causes of trouble will require that a specific test be performed. These tests are given a procedure letter which will be found in the “Test Procedure” section.

CAUTION

If the oven becomes inoperative because of a blown monitor fuse, check the monitor switch, relay (RY1) primary interlock relay (RY2), door sensing switch and secondary interlock switch before replacing the monitor fuse. If the monitor fuse is replaced, the monitor switch must also be replaced. Use part FFS-BA042WRKZ as an assembly.

WARNING

WHENEVER TROUBLESHOOTING IS PERFORMED WITH THE POWER SUPPLY CORD DISCONNECTED. IT MAY IN, SOME CASES, BE NECESSARY TO CONNECT THE POWER SUPPLY CORD AFTER THE OUTER CASE HAS BEEN REMOVED, IN THIS EVENT:

1. DISCONNECT THE POWER SUPPLY CORD, AND THEN REMOVE OUTER CASE.
2. OPEN THE DOOR AND BLOCK IT OPEN.
3. TO DISCHARGE HIGH VOLTAGE CAPACITOR, WAIT FOR 60 SECONDS AND THEN SHORT-CIRCUIT THE CONNECTION OF THE HIGH-VOLTAGE CAPACITOR (THAT IS THE CONNECTING LEAD OF THE HIGH-VOLTAGE RECTIFIER) AGAINST THE CHASSIS WITH THE USE OF AN INSULATED SCREWDRIVER.
4. REMOVE THE BACK PLATE FROM THE OVEN.
5. DISCONNECT THE LEADS TO THE PRIMARY OF THE POWER TRANSFORMER.
6. ENSURE THAT LEADS REMAIN ISOLATED FROM OTHER COMPONENTS AND OVEN CHASSIS BY USING INSULATION TAPE.
7. AFTER THAT PROCEDURE, RECONNECT THE POWER SUPPLY CORD.

WARNING

WHEN THE TESTING IS COMPLETED:

1. DISCONNECT THE POWER SUPPLY CORD, AND THEN REMOVE OUTER CASE.
2. OPEN THE DOOR AND BLOCK IT OPEN.
3. TO DISCHARGE HIGH VOLTAGE CAPACITOR, WAIT FOR 60 SECONDS AND THEN SHORT-CIRCUIT THE CONNECTION OF THE HIGH-VOLTAGE CAPACITOR (THAT IS THE CONNECTING LEAD OF THE HIGH-VOLTAGE RECTIFIER) AGAINST THE CHASSIS WITH THE USE OF AN INSULATED SCREWDRIVER.
4. RECONNECT THE LEADS TO THE PRIMARY OF THE POWER TRANSFORMER.
5. REINSTALL THE OUTER CASE (CABINET).
6. RECONNECT THE POWER SUPPLY CORD AFTER THE OUTER CASE IS INSTALLED.
7. RUN THE OVEN AND CHECK ALL FUNCTIONS.

Microwave ovens should not be run empty. To test for the presence of microwave energy within a cavity, place a cup of cold water on the oven turntable, close the door and set the power to HIGH and then set the microwave timer for two (2) minutes. When the two minutes has elapsed (timer at zero) carefully check that the water is now hot. If the water remains cold carry out Before Servicing procedure and re-examine the connections to the component being tested.

When all service work is completed and the oven is fully assembled, the microwave power output should be checked and a microwave leakage test should be carried out.

Test Procedures

Procedure Letter	Component Test
A	<p>MAGNETRON ASSEMBLY TEST</p> <p> WARNING</p> <p>HIGH VOLTAGES ARE PRESENT DURING THE COOK CYCLE, SO EXTREME CAUTION SHOULD BE OBSERVED. DISCHARGE THE HIGH VOLTAGE CAPACITOR BEFORE TOUCHING ANY OVEN COMPONENTS OR WIRING.</p> <ol style="list-style-type: none"> 1. Disconnect the power supply cord and then remove outer case. 2. Open the oven door and block it open. 3. Discharge the high voltage capacitor. (See Warnings and Instructions on page 3-1) 4. To test for an open filament, isolate the magnetron from the high voltage circuit. A continuity check across the magnetron filament leads should indicate less than 1 ohm. 5. To test for a shorted magnetron, connect the ohmmeter leads between the magnetron filament leads and chassis ground. This test should indicate an infinite resistance. If there is little or no resistance the magnetron is grounded and must be replaced. 6. Reconnect all leads removed from components during testing. 7. Reinstall the outer case (cabinet). 8. Reconnect the power supply cord after the outer case is installed. 9. Run the oven and check all functions. <p>Power output of the magnetron can be measured by performing a water temperature rise test. This test should only be used if above tests do not indicate a faulty magnetron and there is no defect in the following components or wiring: silicon rectifier, high voltage capacitor and power transformer. This test will require a 16 ounce (453 cc.) measuring cup and an accurate mercury thermometer or thermocouple type temperature tester. For accurate results, the following procedure must be followed carefully:</p> <ol style="list-style-type: none"> 1. Fill the measuring cup with 16 oz. (453 cc.) of tap water and measure the temperature of the water with a thermometer or thermocouple temperature tester. Stir the thermometer or thermocouple through the water until the temperature stabilizes. Record the temperature of the water. 2. Place the cup of water in the oven. Operate oven at POWER 10(HIGH) selecting more than 60 seconds cook time. Allow the water to heat for 60 seconds, measuring with a stop watch, second hand of a watch or the digital read-out countdown. 3. Remove the cup from the oven and again measure the temperature, making sure to stir the thermometer or thermocouple through the water until the maximum temperature is recorded. 4. Subtract the cold water temperature from the hot water temperature. The normal result should be 29.2 to 54.2°F(16.2 to 30.1°C) rise in temperature. If the water temperatures are accurately measured and tested for the required time period the test results will indicate if the magnetron tube has low power output (low rise in water temperature) which would extend cooking time or high power output (high rise in water temperature) which would reduce cooking time. Because cooking time can be adjusted to compensate for power output, the magnetron tube assembly should be replaced only if the water temperature rise test indicates a power output well beyond the normal limits. The test is only accurate if the power supply line voltage is 120 volts and the oven cavity is clean.

Troubleshooting and Testing

Procedure Letter	Component Test
<p>B</p>	<p>POWER TRANSFORMER TEST</p> <p>⚠ WARNING</p> <p>DO NOT TOUCH THE COMPONENTS OF THE POWER TRANSFORMER WHILE POWER TRANSFORMER IS ENERGIZED. IT IS DANGEROUS BECAUSE THIS HAS HIGH VOLTAGE COMPONENTS. (HIGH VOLTAGES ARE PRESENT AT THE HIGH VOLTAGE TERMINAL, SO DO NOT ATTEMPT TO MEASURE THE FILAMENT AND HIGH VOLTAGE.)</p> <ol style="list-style-type: none"> 1. Disconnect the power supply cord, and then remove outer case. 2. Open the door and block it open. 3. Discharge high voltage capacitor. (See Warnings and Instructions on page 3-1) 4. Disconnect the primary input terminals and measure the resistance of the transformer with an ohmmeter. Check for continuity of the coils with an ohmmeter. On the R x 1 scale, the resistance of the primary coil should be less than 1 ohm and the resistance of the high voltage coil should be approximately 85 ohms (RTRN-A774WRZZ)/ approximately 103.5 ohms (RTRN-A777WRZZ); the resistance of the filament coil should be less than 1 ohm. 5. Reconnect all leads removed from components during testing. 6. Reinstall the outer case (cabinet). 7. Reconnect the power supply cord after the outer case is installed. 8. Run the oven and check all functions.
<p>C</p>	<p>HIGH VOLTAGE RECTIFIER TEST</p> <ol style="list-style-type: none"> 1. Disconnect the power supply cord, and then remove outer case. 2. Open the door and block it open. 3. Discharge high voltage capacitor. (See Warnings and Instructions on page 3-1) 4. Isolate the rectifier from the circuit. Using the highest ohm scale of the meter, read the resistance across the terminals and observe, reverse the leads to the rectifier terminals and observe meter reading. If a short is indicated in both directions, or if an infinite resistance is read in both directions, the rectifier is probably defective and should be replaced. 5. Reconnect all leads removed from components during testing. 6. Reinstall the outer case (cabinet). 7. Reconnect the power supply cord after the outer case is installed. 8. Run the oven and check all functions. <p>NOTE: Be sure to use an ohmmeter that will supply a forward bias voltage of more than 6.3 volts.</p>
<p>D</p>	<p>HIGH VOLTAGE CAPACITOR TEST</p> <ol style="list-style-type: none"> 1. Disconnect the power supply cord, and then remove outer case. 2. Open the door and block it open. 3. Discharge high voltage capacitor. (See Warnings and Instructions on page 3-1) 4. If the capacitor is open, no high voltage will be available to the magnetron. Disconnect input leads and check for short or open between the terminals using an ohmmeter. Checking with a high ohm scale, if the high voltage capacitor is normal, the meter will indicate continuity for a short time and should indicate an open circuit once the capacitor is charged. If the above is not the case, check the capacitor with an ohmmeter to see if it is shorted between either of the terminals and case. If it is shorted, replace the capacitor. 5. Reconnect all leads removed from components during testing. 6. Reinstall the outer case (cabinet). 7. Reconnect the power supply cord after the outer case is installed. 8. Run the oven and check all functions.

Procedure Letter	Component Test
E	<p>CAVITY THERMAL CUT-OUT TEST</p> <ol style="list-style-type: none"> 1. Disconnect the power supply cord, and then remove outer case. 2. Open the door and block it open. 3. Discharge high voltage capacitor. (See Warnings and Instructions on page 3-1) 4. A continuity check across the thermal cut-out terminals should indicate a closed circuit unless the temperature of the thermal cut-out reaches approximately 293°F(145°C). An open thermal cut-out indicates overheating of the oven, exchange the oven thermal cut-out and check inside of oven cavity and for improper setting of cooking time or operation of control unit. Check for restricted air flow through the vent holes of the oven cavity, especially the cooling fan and air guide. 5. Reconnect all leads removed from components during testing. 6. Reinstall the outer case (cabinet). 7. Reconnect the power supply cord after the outer case is installed. 8. Run the oven and check all functions. <p>MAGNETRON TEMPERATURE FUSE TEST</p> <ol style="list-style-type: none"> 1. Disconnect the power supply cord, and then remove outer case. 2. Open the door and block it open. 3. Discharge high voltage capacitor. (See Warnings and Instructions on page 3-1) 4. A continuity check across the C/T fuse terminals should indicate a closed circuit unless the temperature of the cavity temperature fuse reaches approximately 302°F(150°C). An open cavity temperature fuse indicates overheating of the oven, exchange the cavity temperature fuse and check inside of oven cavity and for improper setting of cooking time or operation of control unit. Check for restricted air flow through the vent holes of the oven cavity, especially the cooling fan and air guide. <div style="background-color: #e0e0e0; padding: 5px; margin: 10px 0;"> <p> CAUTION</p> </div> <div style="background-color: #e0e0e0; padding: 5px; margin: 10px 0;"> <p>If the temperature fuse indicates an open circuit at room temperature, replace temperature fuse.</p> </div> <ol style="list-style-type: none"> 5. Reconnect all leads removed from components during testing. 6. Reinstall the outer case (cabinet). 7. Reconnect the power supply cord after the outer case is installed. 8. Run the oven and check all functions.

Troubleshooting and Testing

Procedure Letter	Component Test
F	<p>SECONDARY INTERLOCK SWITCH TEST</p> <ol style="list-style-type: none"> 1. Disconnect the power supply cord, and then remove outer case. 2. Open the door and block it open. 3. Discharge high voltage capacitor. (See Warnings and Instructions on page 3-1) 4. Isolate the switch and connect the ohmmeter to the common (COM.) and normally open (NO) terminal of the switch. The meter should indicate an open circuit with the door open and a closed circuit with the door closed. If improper operation is indicated, replace the secondary interlock switch. 5. Reconnect all leads removed from components during testing. 6. Reinstall the outer case (cabinet). 7. Reconnect the power supply cord after the outer case is installed. 8. Run the oven and check all functions.
G	<p>PRIMARY INTERLOCK SYSTEM TEST</p> <p>DOOR SENSING SWITCH</p> <ol style="list-style-type: none"> 1. Disconnect the power supply cord, and then remove outer case. 2. Open the door and block it open. 3. Discharge high voltage capacitor. (See Warnings and Instructions on page 3-1) 4. Isolate the switch and connect the ohmmeter to the common (COM.) and normally open (NO) terminal of the switch. The meter should indicate an open circuit with the door open and a closed circuit with the door closed. If improper operation is indicated, replace the door sensing switch. 5. Reconnect all leads removed from components during testing. 6. Reinstall the outer case (cabinet). 7. Reconnect the power supply cord after the outer case is installed. 8. Run the oven and check all functions. <p>NOTE: If the door sensing switch contacts fail in the open position and the door is closed, the cooling fan, turntable and oven light will be activated by RY1.</p> <p>PRIMARY INTERLOCK RELAY (RY2)</p> <ol style="list-style-type: none"> 1. Disconnect the power supply cord, and then remove outer case. 2. Open the door and block it open. 3. Discharge high voltage capacitor. (See Warnings and Instructions on page 3-1) 4. Disconnect two (2) wire leads from the male tab terminals of the Primary Interlock Relay. Check the state of the relay contacts using an ohmmeter. The relay contacts should be open. If the relay contacts are closed, replace the circuit board entirely or the relay itself. 5. Reconnect all leads removed from components during testing. 6. Reinstall the outer case (cabinet). 7. Reconnect the power supply cord after the outer case is installed. 8. Run the oven and check all functions.

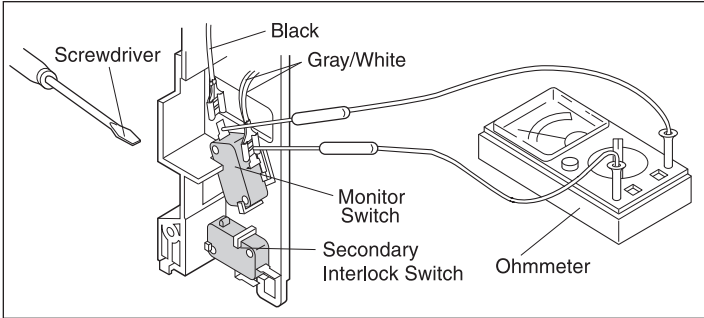
Procedure Letter	Component Test
<p>H</p>	<p>MONITOR SWITCH TEST</p> <ol style="list-style-type: none"> 1. Disconnect the power supply cord, and then remove outer case. 2. Open the door and block it open. 3. Discharge high voltage capacitor. (See Warnings and Instructions on page 3-1) 4. Before performing this test, make sure that the secondary interlock switch and primary interlock relay are operating properly, according to the Switch Test Procedure. Disconnect the wire lead from monitor switch (COM) terminal. Check monitor switch operation by using the ohmmeter as follows. When the door is open, the meter should indicate a closed circuit. When the monitor switch actuator is pushed by a screwdriver through the lower latch hole on the front plate of the oven cavity with the door opened (in this condition the plunger of the monitor switch is pushed in), the meter should indicate an open circuit. If improper operation is indicated, the switch may be defective. After testing the monitor switch, reconnect the wire lead to the monitor switch (COM) terminal and check the continuity of the monitor circuit. 5. Reconnect all leads removed from components during testing. 6. Reinstall the outer case (cabinet). 7. Reconnect the power supply cord after the outer case is installed. 8. Run the oven and check all functions. 
<p>I</p>	<p>BLOWN MONITOR FUSE TEST</p> <ol style="list-style-type: none"> 1. Disconnect the power supply cord, and then remove outer case. 2. Open the door and block it open. 3. Discharge high voltage capacitor. (See Warnings and Instructions on page 3-1) 4. If the monitor fuse is blown when the door is opened, check the secondary interlock switch, primary interlock relay (RY2), relay (RY1) and monitor switch according to the “Test Procedure” for those switches before replacing the blown monitor fuse. <p>⚠ CAUTION</p> <p>Before replacing a blown monitor fuse, test the secondary interlock switch, primary interlock relay, door sensing switch and monitor switch for proper operation.</p> <p>If the monitor fuse is blown by improper switch operation, the monitor fuse and monitor switch must be replaced with “monitor fuse and monitor switch assembly” even if the monitor switch operates normally. The monitor fuse and monitor switch assembly is comprised of a 20 ampere fuse and switch.</p> <ol style="list-style-type: none"> 5. Reconnect all leads removed from components during testing. 6. Reinstall the outer case (cabinet). 7. Reconnect the power supply cord after the outer case is installed. 8. Run the oven and check all functions.

Troubleshooting and Testing

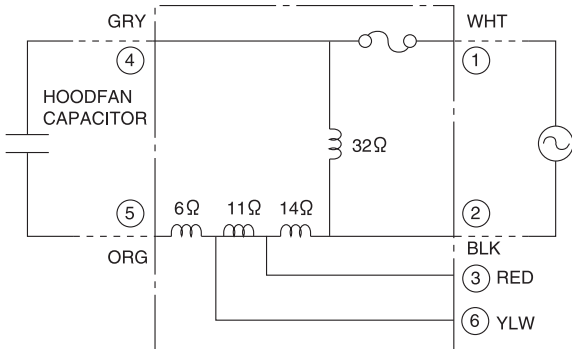
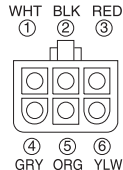
Procedure Letter	Component Test
<p>J</p>	<p>HOOD THERMOSTAT TEST</p> <p>Thermostat (60°C ON)</p> <ol style="list-style-type: none"> 1. Disconnect the power supply cord, and then remove outer case. 2. Open the door and block it open. 3. Discharge high voltage capacitor. (See Warnings and Instructions on page 3-1) 4. A continuity check across the thermal cut-out terminals should indicate an open circuit unless temperature of thermal cut-out reaches approximately 140°F (60°C) or more. At that temperature, the contacts will close. The thermal cut-out opens automatically at approximately 113°F (45°C). 5. Reconnect all leads removed from components during testing. 6. Reinstall the outer case (cabinet). 7. Reconnect the power supply cord after the outer case is installed. 8. Run the oven and check all functions. <p>Thermostat (70°C OFF)</p> <ol style="list-style-type: none"> 1. Disconnect the power supply cord, and then remove outer case. 2. Open the door and block it open. 3. Discharge high voltage capacitor. (See Warnings and Instructions on page 3-1) 4. A continuity check across the thermal cut-out terminals should indicate a closed circuit unless the temperature of the thermal cut-out reaches approximately 158°F (70°C) or more. At that temperature, the contacts will open. The thermal cut-out closes automatically at approximately 131°F (55°C). 5. Reconnect all leads removed from components during testing. 6. Reinstall the outer case (cabinet). 7. Reconnect the power supply cord after the outer case is installed. 8. Run the oven and check all functions.
<p>K</p>	<p>BLOWN MONITOR FUSE TEST</p> <ol style="list-style-type: none"> 1. Disconnect the power supply cord, and then remove outer case. 2. Open the door and block it open. 3. Discharge high voltage capacitor. (See Warnings and Instructions on page 3-1) 4. If motor does not turn, touch FAN HI/MID/LO pad once (set hood fan motor power "HIGH") and check voltage between pins "1" and "2" (Blue and Black wires) of the 6 pin connector. If 120 Volts appear and the hood capacitor is good, replace the hood fan assembly. If 120 Volts does not appear, check the motor circuit. The resistance values of motor terminals are as follows: <div style="display: flex; align-items: flex-start;"> <div style="flex: 1;">  </div> <div style="flex: 1; padding-left: 20px;"> <p><u>Resistance between:</u></p> <p>WHT(1) AND GRY(4) = 0 Ω (shorted)</p> <p>BLK(2) AND GRY(4) = 32 Ω</p> <p>WHT(1) AND BLK(2) = 32 Ω</p> <p>BLK(2) AND RED(3) = 14 Ω</p> <p>RED(3) AND YLW(6) = 11 Ω</p> <p>ORG(5) AND YLW(6) = 6 Ω</p> </div> <div style="flex: 0.5; text-align: center;">  <p>6-PIN CONNECTOR OF HOOD FAN MOTOR</p> </div> </div> <ol style="list-style-type: none"> 5. Reconnect all leads removed from components during testing. 6. Reinstall the outer case (cabinet). 7. Reconnect the power supply cord after the outer case is installed. 8. Run the oven and check all functions.

Procedure Letter	Component Test
L	<p>TOUCH CONTROL PANEL ASSEMBLY TEST</p> <p>The touch control panel consists of circuits including semiconductors such as LSI, ICs, etc. Therefore, unlike conventional microwave ovens, proper maintenance cannot be performed with only a voltmeter and ohmmeter. In this service manual, the touch control panel assembly is divided into two units, Control Unit and Glass Touch Key Unit, and troubleshooting by unit replacement is described according to the symptoms indicated.</p> <p>Before testing,</p> <ol style="list-style-type: none"> 1. Disconnect the power supply cord, and then disassemble as per “Hood Louver Removal”, “Removal Of Oven From Wall” And “Outer Case Removal”. 2. Open the door and block it open. 3. Discharge high voltage capacitor. (See Warnings and Instructions on page 3-1) 4. Disconnect the leads to the primary of the power transformer. 5. Ensure that these leads remain isolated from other components and oven chassis by using insulation tape. 6. After that procedure, re-connect the power supply cord. <p>Glass Touch Key Unit</p> <ol style="list-style-type: none"> 1. Check glass touch key unit connection before replacement. 2. Reconnect all leads removed from components during testing. 3. Reconnect the power supply cord after the covers are installed. 4. Run the oven and check all functions. <p>The following symptoms indicate a defective glass touch key unit.</p> <ol style="list-style-type: none"> a) When touching the pads, a certain pad produces no signal at all. b) When touching a number pad, two figures or more are displayed. c) When touching the pads, sometimes a pad produces no signal. <p>If the keyboard unit is defective.</p> <ol style="list-style-type: none"> 1. Disconnect the power supply cord and then remove outer case. 2. Open the door and block it open. 3. Discharge high voltage capacitor. (See Warnings and Instructions on page 3-1) 4. Replace the door frame assembly. 5. Reconnect all leads removed from components during testing. 6. Reconnect the power supply cord. 7. Run the oven and check all functions. <p>Control Unit</p> <p>The following symptoms indicate a defective control unit. Before replacing the control unit, perform the glass touch key unit test (Procedure M) to determine if control unit is faulty.</p> <ol style="list-style-type: none"> 1. In connection with indicators: <ol style="list-style-type: none"> a) At a certain digit, all or some segments do not light up. b) At a certain digit, brightness is low. c) Only one indicator does not light. d) The corresponding segments of all digits do not light up; or they continue to light up. e) Wrong figure appears. f) A certain group of indicators do not light up. g) The figure of all digits flicker. <p>continued on next page</p>



Troubleshooting and Testing

Procedure Letter	Component Test
	<p>2. Other possible problems caused by defective control unit.</p> <ul style="list-style-type: none"> a) Buzzer does not sound or continues to sound. b) Clock does not operate properly. c) Cooking is not possible. d) Fan motor, antenna motor, oven lamp or electrical parts do not turn on or do not turn off. e) Digital display on the control unit does not show anything. <p>When testing is completed,</p> <ul style="list-style-type: none"> 1. Disconnect the power supply cord, and then remove outer case. 2. Open the door and block it open. 3. Discharge high voltage capacitor. (See Warnings and Instructions on page 3-1) 4. Reconnect all leads removed from components during testing. 5. Re-install the outer case (cabinet). 6. Reconnect the power supply cord after the outer case is installed. 7. Run the oven and check all functions.
M	<p>GLASS TOUCH KEY UNIT TEST</p> <p>Before testing:</p> <ul style="list-style-type: none"> 1. Disconnect the power supply cord, and then remove the outer case. 2. Open the door and block it open. 3. Discharge high voltage capacitor. (See Warnings and Instructions on page 3-1) 4. Disconnect the leads to the primary of the power transformer. 5. Ensure that these leads remain isolated from other components and oven chassis by using insulation tape. 6. After that procedure, re-connect the power supply cord. <p>Testing:</p> <ul style="list-style-type: none"> 7. Disconnect the power supply cord, and then reconnect power supply cord. Display should show the words: "ENJOY YOUR OVEN TOUCH CLEAR AND TOUCH CLOCK." in the display. 8. Wait 3 sec. and press the following keys within 20 seconds: "Power Level" then "Set Clock" then "Start / add 30 sec" then "Stop Clear". Test mode should start checking each digit. 9. After each digit is confirmed, press every key on Glass touch key unit. <p>NOTE: At this time, oven lamp, hood lamp, fan motor, hood fan or some electric parts may operate by pressing keys. But please ignore operations of the electric parts.</p> <ul style="list-style-type: none"> 10. After every key is pressed, open door and verify the following display: OK 11. If any other code is displayed, one or more Key pads are bad and the Glass touch key unit will be defective. Remove the old glass touch key unit and install the new one (as the normal glass touch key unit). 12. Reconnect the wire harness to the glass touch key unit. <p>After testing:</p> <ul style="list-style-type: none"> 13. Disconnect the power supply cord and then remove outer case. 14. Open the door and block it open. 15. Discharge high voltage capacitor. (See Warnings and Instructions on page 3-1) 16. Reconnect all leads removed from components during testing. 17. Reconnect the power supply cord. 18. Run the oven and check all functions.

Procedure Letter	Component Test																								
N	<p>RELAY TEST</p> <ol style="list-style-type: none"> 1. Disconnect power supply cord, and remove outer case. 2. Open the door and block it open. 3. Discharge high voltage capacitor. (See Warnings and Instructions on page 3-1) 4. Disconnect the leads to the primary of the power transformer. 5. Ensure that these leads remain isolated from other components and oven chassis by using insulation tape. 6. After that procedure, re-connect the power supply cord. 7. Remove the outer case and check voltage between Pin No. 1 of the 3 pin connector (A) and the oven side terminal of the relay RY1 on the control unit with an A.C. voltmeter. The meter should indicate 120 volts, if not check oven circuit. <p>Shut-off, Cook and Heater Relays Test These relays are operated by D.C. voltage Check voltage at the relay coil with a D.C. voltmeter during the microwave cooking operation. DC. voltage indicated Defective relay. DC. voltage not indicated Check diode which is connected to the relay coil. If diode is good, control unit is defective.</p> <table border="1" style="width: 100%; border-collapse: collapse; margin: 10px 0;"> <thead> <tr> <th style="text-align: center;">RELAY SYMBOL</th> <th style="text-align: center;">OPERATIONAL VOLTAGE</th> <th style="text-align: center;">CONNECTED COMPONENTS</th> </tr> </thead> <tbody> <tr> <td>RY1</td> <td>Approx. 24.0V D.C.</td> <td>Oven lamp / Fan motor / Antenna motor</td> </tr> <tr> <td>RY2</td> <td>Approx. 24.0V D.C.</td> <td>Power transformer</td> </tr> <tr> <td>RY3</td> <td>Approx. 24.0V D.C.</td> <td>Turntable motor</td> </tr> <tr> <td>RY4</td> <td>Approx. 24.0V D.C.</td> <td>Hood motor (HIGH/MED selection)</td> </tr> <tr> <td>RY5</td> <td>Approx. 24.0V D.C.</td> <td>Hood motor (HIGH/MED/LOW selection)</td> </tr> <tr> <td>RY6</td> <td>Approx. 24.0V D.C.</td> <td>Hood motor</td> </tr> <tr> <td>RY7, RY8, RY9</td> <td>Approx. 24.0V D.C.</td> <td>Hood lamp</td> </tr> </tbody> </table> <ol style="list-style-type: none"> 8. If any abnormal condition is defected, replace the control unit. 9. Disconnect the power supply cord and then remove outer case. 10. Open the door and block it open. 11. Discharge high voltage capacitor. (See Warnings and Instructions on page 3-1) 12. Reconnect all leads removed from components during testing. 13. Re-install the outer case (cabinet). 14. Reconnect the power supply cord after the outer case is installed. 15. Run the oven and check all functions. 	RELAY SYMBOL	OPERATIONAL VOLTAGE	CONNECTED COMPONENTS	RY1	Approx. 24.0V D.C.	Oven lamp / Fan motor / Antenna motor	RY2	Approx. 24.0V D.C.	Power transformer	RY3	Approx. 24.0V D.C.	Turntable motor	RY4	Approx. 24.0V D.C.	Hood motor (HIGH/MED selection)	RY5	Approx. 24.0V D.C.	Hood motor (HIGH/MED/LOW selection)	RY6	Approx. 24.0V D.C.	Hood motor	RY7, RY8, RY9	Approx. 24.0V D.C.	Hood lamp
RELAY SYMBOL	OPERATIONAL VOLTAGE	CONNECTED COMPONENTS																							
RY1	Approx. 24.0V D.C.	Oven lamp / Fan motor / Antenna motor																							
RY2	Approx. 24.0V D.C.	Power transformer																							
RY3	Approx. 24.0V D.C.	Turntable motor																							
RY4	Approx. 24.0V D.C.	Hood motor (HIGH/MED selection)																							
RY5	Approx. 24.0V D.C.	Hood motor (HIGH/MED/LOW selection)																							
RY6	Approx. 24.0V D.C.	Hood motor																							
RY7, RY8, RY9	Approx. 24.0V D.C.	Hood lamp																							

Troubleshooting and Testing

Procedure Letter	Component Test									
O	<p>PROCEDURES TO BE TAKEN WHEN THE FUSE ON THE PRINTED WIRING BOARD (PWB) IS OPEN</p> <p>To protect the electronic circuits, this model is provided with a fuse added to the primary on the PWB.</p> <p>1. Fuse check and repairs.</p> <ol style="list-style-type: none"> a) Disconnect the power supply cord. b) Remove the covers. c) Open the door and block it open. d) Discharge high voltage capacitor. (See Warnings and Instructions on page 3-1) e) If the Fuse is blown, replace power unit. f) Make a visual inspection of the varistor. Check for burned damage. If the varistor has been burned, replace the power unit. g) Examine the touch control transformer with a tester for the presence of layer short-circuit (check the primary coil resistance which is approximately $110W \pm 10\%$). If any abnormal condition is detected, replace the touch control transformer. h) Reconnect all leads removed from components during testing. i) Re-install the covers. j) Reconnect the power supply cord after the covers are installed. k) Run the oven and check all functions. <p>2. Follow the troubleshooting guide given below, if indicator does not light up after above check and repairs are finished.</p> <ol style="list-style-type: none"> a) Disconnect the power supply cord. b) Remove the covers. c) Open the door and block it open. d) Discharge high voltage capacitor. (See Warnings and Instructions on page 3-1) e) Disconnect the leads to the primary of the power transformer. f) Ensure that these leads remain isolated from other components and oven chassis by using insulation tape. g) After that procedure, re-connect the power supply cord. h) Follow the troubleshooting guide given below for repair. <table border="1" data-bbox="302 1371 1458 1499" style="width: 100%; border-collapse: collapse;"> <thead> <tr> <th style="width: 10%;">STEPS</th> <th style="width: 50%;">OCCURRENCE</th> <th style="width: 40%;">CAUSE OR CORRECTION</th> </tr> </thead> <tbody> <tr> <td style="text-align: center;">1</td> <td>The rated AC voltage is not present between Pin No. 1 of the 3-pin connector (A) and the oven side terminal of the relay RY1</td> <td>Check supply voltage and oven power cord.</td> </tr> <tr> <td style="text-align: center;">2</td> <td>The rated AC voltage is present at primary side of touch control transformer.</td> <td>Touch control transformer or secondary circuit defective. Check and replace the control unit.</td> </tr> </tbody> </table> <ol style="list-style-type: none"> i) Disconnect the power supply cord, and then remove the covers. j) Open the door and block it open. k) Discharge high voltage capacitor. (See Warnings and Instructions on page 3-1) l) Reconnect all leads removed from components during testing. m) Re-install the covers. n) Reconnect the power supply cord after the covers are installed. o) Run the oven and check all functions. 	STEPS	OCCURRENCE	CAUSE OR CORRECTION	1	The rated AC voltage is not present between Pin No. 1 of the 3-pin connector (A) and the oven side terminal of the relay RY1	Check supply voltage and oven power cord.	2	The rated AC voltage is present at primary side of touch control transformer.	Touch control transformer or secondary circuit defective. Check and replace the control unit.
STEPS	OCCURRENCE	CAUSE OR CORRECTION								
1	The rated AC voltage is not present between Pin No. 1 of the 3-pin connector (A) and the oven side terminal of the relay RY1	Check supply voltage and oven power cord.								
2	The rated AC voltage is present at primary side of touch control transformer.	Touch control transformer or secondary circuit defective. Check and replace the control unit.								

Procedure Letter	Component Test
P	<p>HUMIDITY SENSOR TEST</p> <p>Checking The Initial Sensor Cooking Condition</p> <p> WARNING</p> <p>THE OVEN SHOULD BE FULLY ASSEMBLED BEFORE FOLLOWING PROCEDURE.</p> <ol style="list-style-type: none"> 1. The oven should be plugged in at least two minutes before sensor cooking. 2. Room temperature should not exceed 35°C. 3. The unit should not be installed in any area where heat and steam are generated. The unit should not be installed, for example, next to a conventional surface unit. Refer to the “Installation Instructions”. 4. Exhaust vents are provided on the back of the unit for proper cooling and air flow in the cavity. To permit adequate ventilation, be sure to install so as not to block these vents. There should be some space for air circulation. 5. Be sure the exterior of the cooking container and the interior of the oven are dry. Wipe off any moisture with a dry cloth or paper towel. 6. The Sensor works with food at normal storage temperature. For example, chicken pieces would be at refrigerator temperature and canned soup at room temperature. 7. Avoid using aerosol sprays or cleaning solvents near the oven while using Sensor settings. The sensor will detect the vapor given off by the spray and turn off before food is properly cooked. 8. After the oven is started on sensor cooking condition, if the sensor has not detected the vapor of the food, ERROR will appear and the oven will shut off. <p>Water Load Cooking Test</p> <p> WARNING</p> <p>THE OVEN SHOULD BE FULLY ASSEMBLED BEFORE FOLLOWING PROCEDURE.</p> <p>Make sure the oven has been plugged in at least two minutes before checking sensor cook operation. The cabinet should be installed and screws tightened.</p> <ol style="list-style-type: none"> 1. Fill approximately 200 milliliters of tap water in a 1000 milliliter measuring cup. 2. Place the container on the center of tray in the oven cavity. 3. Close the door. 4. Touch the SET/CLOCK pad once, the POWER LEVEL pad twice and the START pad once. And touch the number pads 1 once and the number pad 2 once. Now, the oven is in the sensor cooking condition, and “AH10” and “COOK” will appear in the display. 5. The oven will operate for the first 32 seconds, without generating microwave energy. <p>NOTE: ERROR will appear if the door is opened or STOP/CLEAR pad is touched during first stage of sensor cooking.</p> <ol style="list-style-type: none"> 6. After approximately 32 seconds, microwave energy is produced. If ERROR is displayed or the oven does not turn off, replace the humidity sensor or check the control unit, refer to explanation on next page. <p>continued on next page</p>

Troubleshooting and Testing

Procedure Letter	Component Test
<p>P</p>	<p>TESTING METHOD FOR HUMIDITY SENSOR AND/OR CONTROL UNIT</p> <p>To determine if the sensor is defective, the simplest method is to replace it with a new replacement sensor.</p> <ol style="list-style-type: none"> 1. Disconnect the power supply cord, and then remove outer case. 2. Open the door and block it open. 3. Discharge high voltage capacitor. (See Warnings and Instructions on page 3-1) 4. Remove the humidity sensor. 5. Install the new humidity sensor. 6. Reconnect all leads removed from components during testing. 7. Re-install the outer case (cabinet). 8. Reconnect the power supply cord after the outer case is installed. 9. Reconnect the oven to the power supply and check the sensor cook operation as follows: <ol style="list-style-type: none"> a) Fill approximately 200 milliliters of tap water in a 1000 milliliter measuring cup. b) Place the container on the center of tray in the oven cavity. c) Close the door. d) Touch the SET/CLOCK pad once, the POWER LEVEL pad twice and the START pad once. And touch the number pads 1 once and the number pad 2 once. e) The control panel is in automatic Sensor operation. f) The oven turns off automatically, and the time for detecting moisture will be displayed. <p>If new sensor dose not operate properly, the problem is with the control unit, and refer to explanation below.</p> <p>CHECKING CONTROL UNIT</p> <ol style="list-style-type: none"> 1. Disconnect the power supply cord, and then remove outer case. 2. Open the door and block it open. 3. Discharge high voltage capacitor. (See Warnings and Instructions on page 3-1) 4. Disconnect the sensor connector that is mounted to control panel. 5. Then connect the dummy resistor circuit (see fig.) to the sensor connector of control panel. 6. Disconnect the leads to the primary of the power transformer. 7. Ensure that these leads remain isolated from other components and oven chassis by using insulation tape. 8. After that procedure, re-connect the power supply cord. 9. Check the sensor cook operation proceed as follows: <ol style="list-style-type: none"> a) Close the door. Touch the SET/CLOCK pad once, the POWER LEVEL pad twice and the START pad once. And touch the number pads 1 once and the number pad 2 once. b) The control panel is in the sensor cooking operation. c) After approximately 41 seconds, push plunger of select switch for more than 3 seconds. This condition is same as judgement by humidity sensor. d) After approximately 3 seconds, the display shows "X X. X X " which is the time for detecting moisture. <p>If the above is not the case, the control unit is probably defective. If the above is proper, the humidity sensor is probably defective.</p> <p>continued on next page</p>

Procedure Letter	Component Test								
P	<p>10. Disconnect the power supply cord, and then remove outer case. 11. Open the door and block it open. 12. Discharge high voltage capacitor. (See Warnings and Instructions on page 3-1) 13. Disconnect the dummy resistor circuit from the sensor connector of control panel. 14. Carry out necessary repair. 15. Reconnect all leads removed from components during testing and repairing. 16. Re-install the outer case (cabinet). 17. Reconnect the power supply cord after the outer case is installed. Run the oven and check all functions. 18. Carry out "Water load cooking test" again and ensure that the oven works properly.</p> <div style="border: 1px solid black; padding: 10px; margin: 10px 0;"> <p style="margin: 0;">R1,R2: 22Ω ±1% 1/2W R3: 4.3kΩ ±5% 1/4W R4: 1MΩ ±5% 1/4W</p> <p style="margin: 0;">To connector (F) on Control Unit.</p> </div> <p style="text-align: center;">Sensor Dummy Resistor Circuit</p>								
Q	<p>NOISE FILTER TEST</p> <ol style="list-style-type: none"> 1. Disconnect the power supply cord, and then remove outer case. 2. Open the door and block it open. 3. Discharge high voltage capacitor. (See Warnings and Instructions on page 3-1) 4. Disconnect the leads to the primary of the power transformer. 5. Using an ohmmeter, check between the terminals as described in the following table. <table border="1" style="width: 100%; border-collapse: collapse; margin: 10px 0;"> <thead> <tr> <th style="text-align: center;">Measuring Point</th> <th style="text-align: center;">Indication Of Ohmmeter</th> </tr> </thead> <tbody> <tr> <td style="text-align: center;">Between N and H</td> <td style="text-align: center;">Approx. 470 KΩ</td> </tr> <tr> <td style="text-align: center;">Between terminal N and LOAD</td> <td style="text-align: center;">Short circuit.</td> </tr> <tr> <td style="text-align: center;">Between terminal H and LOAD</td> <td style="text-align: center;">Short circuit.</td> </tr> </tbody> </table> <p>If incorrect readings are obtained, replace the noise filter.</p> <ol style="list-style-type: none"> 6. Reconnect all leads removed from components during testing. 7. Reinstall the outer case (cabinet). 8. Reconnect the power supply cord after the outer case is installed. 9. Run the oven and check all functions. <div style="text-align: center; margin-top: 10px;"> </div>	Measuring Point	Indication Of Ohmmeter	Between N and H	Approx. 470 KΩ	Between terminal N and LOAD	Short circuit.	Between terminal H and LOAD	Short circuit.
Measuring Point	Indication Of Ohmmeter								
Between N and H	Approx. 470 KΩ								
Between terminal N and LOAD	Short circuit.								
Between terminal H and LOAD	Short circuit.								

Component Teardown and Testing

WARNING

TO PREVENT AN ELECTRIC SHOCK, TAKE THE FOLLOWING PRECAUTIONS:

1. **BEFORE WIRING:**
 - 1) Disconnect the power supply.
 - 2) Open the door and block the door open.
 - 3) Discharge the high voltage capacitor and wait for 60 seconds.
2. **DO NOT LET WIRE LEADS TOUCH TO THE FOLLOWING PARTS:**
 - 1) High voltage parts:
Magnetron, High Voltage Transformer, High Voltage Capacitor And High Voltage Rectifier Assembly.
 - 2) Hot parts:
Oven Lamp, Magnetron, High Voltage Transformer And Oven Cavity.
 - 3) Sharp edge:
Bottom Plate, Oven Cavity, Waveguide Flange, Chassis Support And Other Metallic Plates.
 - 4) Movable parts (to prevent a fault)
Fan Blade, Fan Motor, Switch, Switch Lever, Open Button.
3. Do not catch the wire leads in the outer case cabinet.
4. Insert the positive lock connector completely until its pin is locked. Make sure that the wire leads should not come off even if the wire leads are pulled.
5. To prevent an error function, connect the wire leads correctly, referring to the Pictorial Diagram.

WARNING

AVOID POSSIBLE EXPOSURE TO MICROWAVE ENERGY. PLEASE FOLLOW INSTRUCTIONS BELOW BEFORE OPERATING THE OVEN.

1. Disconnect the power supply cord.
2. Make sure that a definite "click" can be heard when the microwave oven door is unlatched. (Hold the door in a closed position with one hand, then push the door open button with the other, this causes the latch leads to rise, it is then possible to hear a "click" as the door switches operate.)
3. Visually check the door and cavity face plate for damage (dents, cracks, signs of arcing etc.). Carry out any remedial work that is necessary before operating the oven.

DO NOT OPERATE THE OVEN IF ANY OF THE FOLLOWING CONDITIONS EXIST:

1. Door does not close firmly.
2. Door hinge, support or latch hook is damaged.
3. The door gasket or seal is damaged.
4. The door is bent or warped.
5. There are defective parts in the door interlock system.
6. There are defective parts in the microwave generating and transmission assembly.
7. There is visible damage to the oven.

DO NOT OPERATE THE OVEN:

1. Without the RF gasket (Magnetron).
2. If the wave guide or oven cavity are not intact.
3. If the door is not closed.
4. If the outer case (cabinet) is not fitted.

CAUTION

Disconnect oven from power supply before removing outer case.

Discharge high voltage capacitor before touching any oven components or wiring after removing outer case.

Component Teardown and Testing

NOTE

The following adjustments or component replacement can be performed without removing the oven from the wall:

1. Hood lamps, sockets and grease filter.
2. Oven lamp, base cover and lamp glass assembly.
3. Turntable motor.
4. Hood louver.
5. Control panel assembly or components
6. Stirrer cover and stirrer antenna.

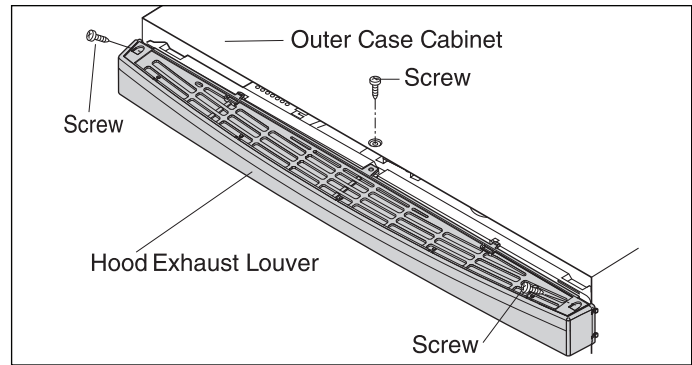

Figure 4-1. Outer Case Removal

Removal Of Oven From Wall

CAUTION

Two persons recommended to remove the oven.

To remove the outer case, proceed as follows:

1. Disconnect the power supply cord, and uncoil the power supply cord.
2. Remove the turntable tray and support from the oven cavity.
3. While supporting the front of the oven, unfasten the two (2) screws holding the oven to the unit mounting plate.
4. While supporting the oven, remove the two (2) screws holding the oven (outer case cabinet) to the top cabinet.
5. Remove the oven from the unit mounting plate and pull the power cord out of the wall cabinet.
6. The oven is now free and can be placed on the work surface selected for servicing the oven.
7. Installation is the reverse of this procedure.

Hood Louver Removal

1. Disconnect the power supply cord.
2. Open the oven door and block it open.
3. Remove the one (1) screw holding the outer case cabinet to the oven cavity front face plate (the position is front/ center on the outer case cabinet).
4. Remove the two (2) screws holding the hood louver to the oven cavity.
5. Remove the hood louver from the over by pushing the right and left tabs of the hood louver.
6. Now, the hood louver is free.

Outer Case Removal

To remove the outer case, proceed as follows:

1. Disconnect the power supply cord.
2. Open the oven door and block it open.

CAUTION

1. **Disconnect oven from power supply before removing outer case.**
2. **Discharge the high voltage capacitor before touching any oven components or wiring.**
3. Remove the one (1) screw holding the outer case cabinet to the oven cavity front face plate (the position is front/ center on the outer case cabinet).
4. Remove eight (8) screws holding the rear stay to the hood fan motor or the oven, and remove it.
5. Remove the four (4) screws holding the base cover to the outer case cabinet.
6. Remove the six (6) screws from the rear of the outer case cabinet.
7. Slide the outer case cabinet back about 1 inch (3 cm) to free it from retaining clips on the cavity face plate.
8. Disconnect the three (3) pin connector of the power supply cord from the wiring harness and remove the power supply cord together with the outer case.
9. Discharge high voltage capacitor.

CAUTION

To discharge the high voltage capacitor, wait for 60 seconds and then short-circuit the connection of the high-voltage capacitor (that is the connecting lead of the high-voltage rectifier) against the chassis with the use of an insulated screwdriver.

Component Teardown and Testing

Power Transformer Removal

Removal

1. Disconnect the power supply cord and then remove outer case.
2. Open the oven door and block it open.
3. Discharge high voltage capacitor.

⚠ CAUTION

To discharge the high voltage capacitor, wait for 60 seconds and then short-circuit the connection of the high-voltage capacitor (that is the connecting lead of the high-voltage rectifier) against the chassis with the use of an insulated screwdriver.

4. Disconnect filament leads of transformer from the magnetron and capacitor.
5. Disconnect high voltage leads of capacitor from the transformer.
6. Remove one (1) screw holding the capacitor holder to fan duct and remove the capacitor.
7. Disconnect wire leads from transformer.
8. Remove three (3) screws holding the deflector to the cavity face plate and remove the deflector.
9. Remove three (3) screws holding the base cover to the cavity face plate and one (1) screw holding the base cover to the cavity back plate, and remove the base cover.
10. Remove two (2) screws holding the transformer to right base plate.

Re-install

1. Install by sliding the transformer on the right base plate with its primary terminals toward the fan duct.
2. Secure the transformer with two (2) screws to right base plate.
3. Re-connect wire leads (primary and high voltage) to the transformer and filament leads of transformer to magnetron and high voltage capacitor. Refer to "Pictorial Diagram".
4. Re-install the capacitor.
5. Re-install the base cover and the deflector.
6. Re-install the outer case and check that oven is operating properly.

⚠ CAUTION

Make sure the wire leads never touch the fan blade.

Positive Lock® Connector (No-Case Type) Removal

1. Disconnect the power supply cord, and then remove outer case.
2. Open the door and block it open.
3. Discharge high voltage capacitor.

⚠ CAUTION

To discharge the high voltage capacitor, wait for 60 seconds and then short-circuit the connection of the high-voltage capacitor (that is the connecting lead of the high-voltage rectifier) against the chassis with the use of an insulated screwdriver.

4. Push the lever of positive lock® connector.
5. Pull down on the positive lock® connector.

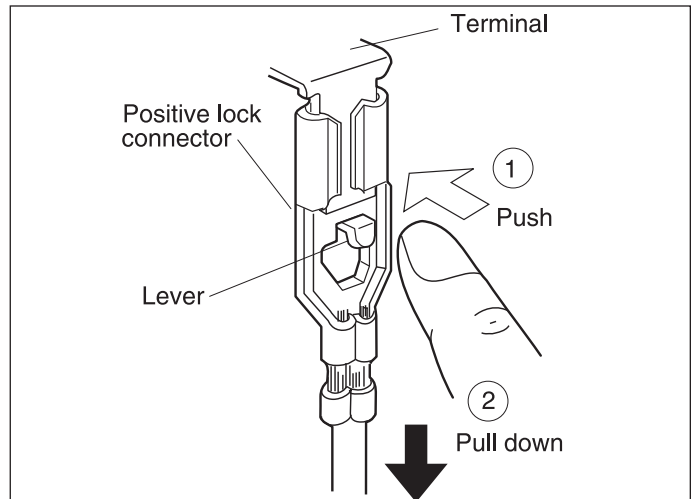

Figure 4-2. Positive Lock® Connector

Component Teardown and Testing

Hood Fan Motor, Hood Duct, Oven Lamp Socket And AH Sensor Removal

1. Disconnect the power supply cord and remove the oven from wall and remove outer case.
2. Open the door and block it open.
3. Discharge high voltage capacitor.

⚠ CAUTION

To discharge the high voltage capacitor, wait for 60 seconds and then short-circuit the connection of the high-voltage capacitor (that is the connecting lead of the high-voltage rectifier) against the chassis with the use of an insulated screwdriver.

4. Remove the hood louver.
5. Remove two (2) screws holding the chassis support right to the rear and face of the oven cavity flanges.
6. Remove two (2) screws holding the chassis support left to rear flange and face of the oven cavity flanges.
7. Remove both chassis supports.
8. Remove the wire tie holding the hood fan harness to the hood duct by cutting it.
9. Disconnect the 6-pin connector of the hood fan motor from the main wire harness located at the right edge of the hood duct. Remove one (1) screw holding the hood intake duct to right base plate. Remove one (1) screw holding the hood duct to the hood intake duct right. Remove the hood intake duct right. Release the snap band from the cavity top plate.
10. Disconnect the two (2) grounding wires from the chassis support left.
11. Now, the hood fan motor is free.
12. Remove the one (1) screw holding the noise filter assembly to the fan duct.
13. Disconnect the connector CN-F and CN-D from the control unit.
14. Remove one (1) screw holding the hood duct to the oven cavity top plate.
15. Remove the one (1) screw holding the hood duct to the fan duct.
16. Release the 6-pin connector and the 3-pin connector of the main harness A from the hood duct.
17. Disconnect the control harness A from the control harness B.
18. Disconnect the connector of control harness A from the cavity face plate.

19. Remove the hood duct from the oven cavity by lifting it up.
20. Release the snap band of control harness A from the hood duct.
21. Release the harness of the sensor assembly and the control harness A from four (4) wire holders of the hood duct.
22. Remove two (2) screws holding the sensor assembly to the hood duct.
23. Now, the sensor assembly is free.
24. Lift the oven lamp cover up and remove the oven lamp cover from hood duct.
25. Remove the oven lamp (Refer to the procedure of "Oven Lamp Removal").
26. Remove the lamp heat cover from hood duct.
27. Disconnect the wire leads from the oven lamp socket.
28. Rotate the oven lamp socket to remove from hood duct.
29. Now, the oven lamp socket is free.

⚠ CAUTION

When the hood fan motor is reinstalled, hold the hood fan motor harness at the right edge of the hood duct with one wire tie.

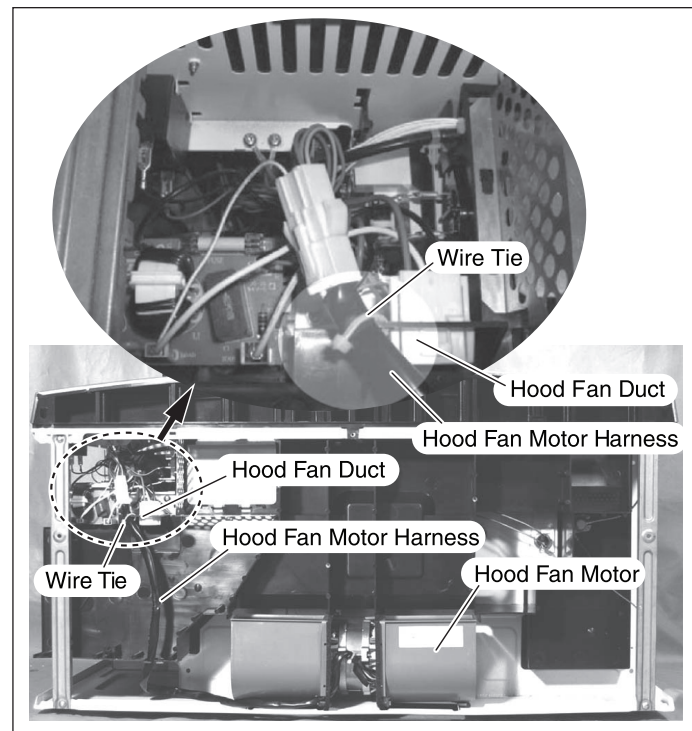

Figure 4-3. Hood Fan Motor Components

Component Teardown and Testing

Magnetron Removal

1. Disconnect the power supply cord and then remove outer case.
2. Open the door and block it open.
3. Discharge high voltage capacitor.

CAUTION

To discharge the high voltage capacitor, wait for 60 seconds and then short-circuit the connection of the high-voltage capacitor (that is the connecting lead of the high-voltage rectifier) against the chassis with the use of an insulated screwdriver.

4. Remove two (2) screws holding the chassis support right to the rear and face of the oven cavity flanges.
5. Remove the one (1) screw holding the noise filter assembly to the fan duct.
6. Disconnect the wire leads from the fan motor.
7. Disconnect the high voltage wire leads of the high voltage rectifier assembly from the magnetron.
8. Disconnect the filament lead of the transformer from the magnetron.
9. Remove the one (1) screw holding the hood duct to the fan duct and remove the one (1) screw holding the oven cavity top plate to the fan duct.
10. Remove the one (1) screw holding the right base plate to the fan duct and remove the fan duct assembly.
11. Remove the power transformer from the right base plate, referring to "Power Transformer Removal".
12. Carefully remove four (4) mounting screws holding the magnetron to waveguide. When removing the screws hold the magnetron to prevent it from falling.
13. Remove the magnetron from the unit with care so the magnetron tube should not be hit by any metal object around the tube.

CAUTION

When replacing the magnetron, be sure the R.F. Anode Gasket is in place and mounting screws are tightened securely.

High Voltage Rectifier And High Voltage Capacitor Removal

1. Disconnect the power supply cord and then remove outer case.
2. Open the door and block it open.
3. Discharge high voltage capacitor.

CAUTION

To discharge the high voltage capacitor, wait for 60 seconds and then short-circuit the connection of the high-voltage capacitor (that is the connecting lead of the high-voltage rectifier) against the chassis with the use of an insulated screwdriver.

4. Disconnect the high voltage wire leads with high voltage rectifier from the magnetron.
5. Disconnect filament lead of the transformer from high voltage capacitor.
6. Disconnect high voltage wire from capacitor.
7. Remove one (1) screw holding capacitor holder and high voltage rectifier to the fan duct.
8. Disconnect the high voltage rectifier assembly from the high voltage capacitor and remove one (1) screw holding the voltage rectifier assembly to the capacitor holder.
9. Now, the high voltage rectifier assembly is free.
10. Remove capacitor from the holder.
11. Now, the high voltage capacitor is free.

CAUTION

When replacing high voltage rectifier and high voltage capacitor, ground side terminal of the high voltage rectifier must be secured firmly with a grounding screw.

Component Teardown and Testing

Hood Fan Thermostat (60°C ON and 70°C OFF) Removal

1. Disconnect the power supply cord and then remove outer case.
2. Open the door and block it open.
3. Discharge high voltage capacitor.

⚠ CAUTION

To discharge the high voltage capacitor, wait for 60 seconds and then short-circuit the connection of the high-voltage capacitor (that is the connecting lead of the high-voltage rectifier) against the chassis with the use of an insulated screwdriver.

4. Disconnect the wire leads from the hood fan thermostat (60°C ON or 70°C OFF).
5. Remove one (1) screw holding the thermostat (60°C ON or 70°C OFF) to the right base plate.
6. Remove the hood fan thermostat (60°C ON or 70°C OFF) from the right base plate.
7. Now, the hood fan thermostat (60°C ON or 70°C OFF) is free.

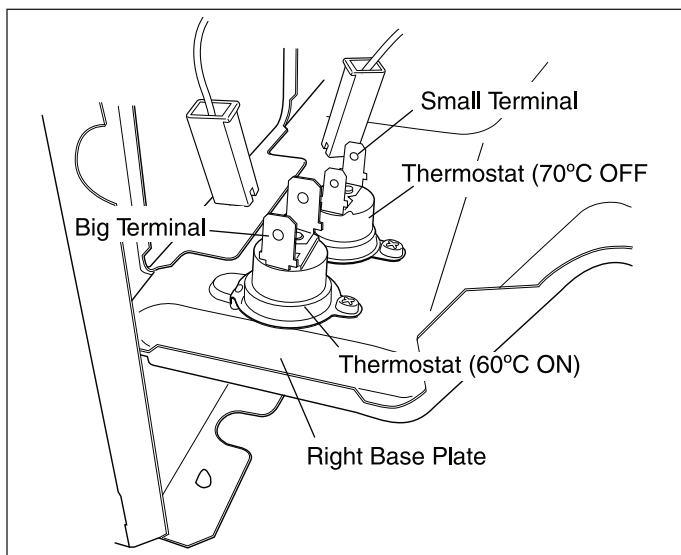

Figure 4-4. Thermostat Removal

Cooling Fan Motor Removal

1. Disconnect the power supply cord and then remove outer case.
2. Open the door and block it open.
3. Discharge high voltage capacitor.

⚠ CAUTION

To discharge the high voltage capacitor, wait for 60 seconds and then short-circuit the connection of the high-voltage capacitor (that is the connecting lead of the high-voltage rectifier) against the chassis with the use of an insulated screwdriver.

4. Remove two (2) screws holding the chassis support right to the rear and face of the oven cavity flange.
5. Remove the one (1) screw holding the noise filter assembly to the fan duct.
6. Disconnect the wire leads from the fan motor.
7. Disconnect the high voltage wire leads of the high voltage rectifier assembly from the magnetron.
8. Disconnect filament lead of transformer from magnetron.
9. Remove the one (1) screw holding the hood duct to the fan duct and remove the one (1) screw holding the oven cavity top plate to the fan duct.
10. Remove the one (1) screw holding the right base plate to fan duct and remove the fan duct assembly.
11. Remove the fan blade from the fan motor shaft according the following procedure.
12. Hold the edge of the rotor of the fan motor by using a pair of groove joint pliers.

⚠ CAUTION

- * Make sure that no metal pieces enter the gap between the rotor and the stator of the fan motor because the rotor is easily shaven by pliers and metal pieces may be produced.
- * Do not touch the pliers to the coil of the fan motor because the coil may be cut or injured.
- * Do not disfigure bracket by touching with pliers.

13. Remove the fan blade from the shaft of the fan motor by pulling and rotating the fan blade with your hand.
14. Now, the fan blade will be free.

⚠ CAUTION

Do not reuse the removed fan blade because the hole (for shaft) may be larger than normal.

Component Teardown and Testing

15. Remove the two (2) screws holding the fan motor to the fan duct.
16. Now, the fan motor is free.

INSTALLATION

1. Install the fan motor to the fan duct with the two (2) screws.
2. Install the fan blade to the fan motor shaft according to the following procedure.
3. Hold the center of the bracket which supports the shaft of the fan motor on the flat table.
4. Apply the screw locktight into the hole (for shaft) of the fan blade.
5. Install the fan blade to the shaft of fan motor by pushing the fan blade with a small, light weight, ball peen hammer or rubber mallet.

CAUTION

- * Do not hit the fan blade strongly when installed because the bracket may be disfigured.
- * Make sure that the fan blade rotates smooth after installation.
- * Make sure that the axis of the shaft is not slanted.

6. Install the fan duct to the oven cavity, base plate right and hood duct with the three (3) screws.
7. Connect the high voltage wire leads with high voltage rectifier from the magnetron, referring to the pictorial diagram.
8. Connect filament lead of the transformer from high voltage capacitor, referring to the pictorial diagram.
9. Connect high voltage wire from capacitor, referring to the pictorial diagram.
10. Connect the wire leads to the fan motor, referring to the pictorial diagram.
11. Re-install the outer case.

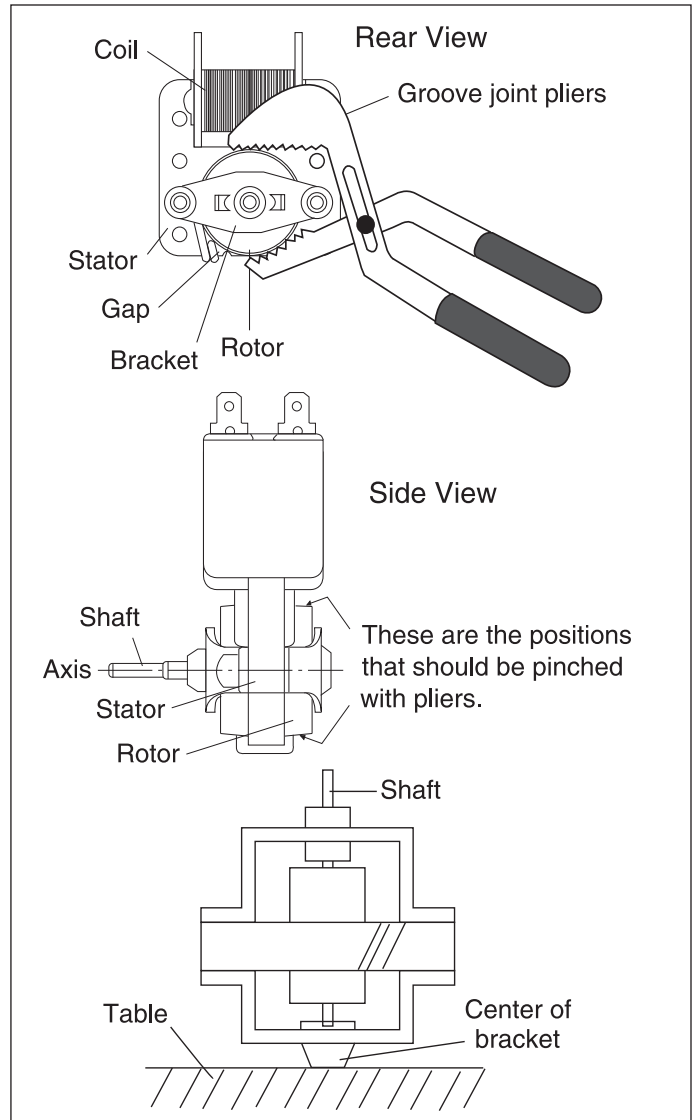

Figure 4-5. Fan Assembly Removal

Turntable Motor Removal

1. Disconnect the power supply cord and then remove outer case.
2. Open the door and block it open.
3. Remove the three (3) screws holding the deflector to the cavity face plate.
4. Remove the four (4) screws holding the base cover to the oven cavity.
5. Remove the base cover from the oven cavity by pulling down and moving to the left slightly.
6. Disconnect the wire leads from the turntable motor.
7. Remove one (1) screw holding turntable motor to the oven cavity.
8. Now the turntable motor is free.

Component Teardown and Testing

Antenna Motor Removal

1. Disconnect the power supply cord and then remove outer case.
2. Open the door and block it open.
3. Discharge high voltage capacitor.

⚠ CAUTION

To discharge the high voltage capacitor, wait for 60 seconds and then short-circuit the connection of the high-voltage capacitor (that is the connecting lead of the high-voltage rectifier) against the chassis with the use of an insulated screwdriver.

4. Remove the hood duct from the oven cavity, referring to the procedure of “Hood Fan Motor, Hood Duct And Oven Lamp Socket Removal”.
5. Disconnect the wire leads from the antenna motor.
6. Remove the one (1) screw holding the antenna motor to the waveguide of the oven cavity.
7. Remove the antenna motor from the waveguide.
8. Now, the antenna motor is free.
9. When installing the antenna motor, the shaft of antenna motor must be inserted to the stirrer antenna shaft. Refer to the procedure of “Stirrer Cover And Stirrer Fan Installation”.

Oven Lamp Removal

1. Disconnect the power supply cord.
2. Remove the hood louver from the oven. (Refer to procedure of “Hood Louver Removal”)
3. Lift the oven lamp cover up.
4. Now, the oven lamp and the socket are found.
5. Screw the oven lamp off from the lamp socket.
6. Now, the oven lamp is free.

Stirrer Cover And Stirrer Fan Installation

1. Put the stirrer antenna on the wave guide to match the stirrer antenna shaft to the center of the stirrer hole.
2. Insert the shaft of stirrer antenna to the shaft of antenna motor.
3. Rotate the antenna holder to lock at the cavity top plate.
4. Insert the cutout of stirrer cover to the tabs on the ceiling.
5. Install the stirrer cover to the oven cavity, and secure it by one canoe clip.

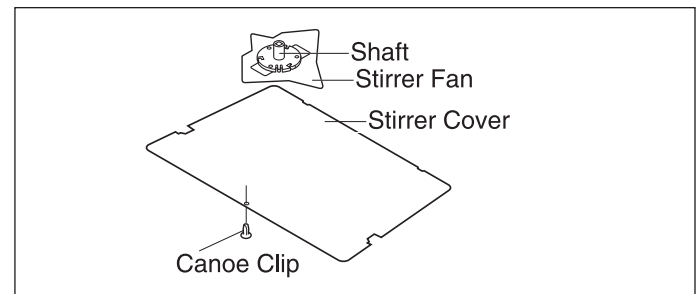

Figure 4-6. Oven Lamp Socket

Servicing For Touch Control Panel

Precautions for Handling Electronic Components

This unit uses CMOS LSI in the integral part of the circuits. When handling these parts, the following precautions should be strictly followed. CMOS LSI have extremely high impedance at its input and output terminals. For this reason, it is easily influenced by the surrounding high voltage power source, static electricity charge in clothes, etc. and sometimes it is not fully protected by the built-in protection circuit.

In order to protect CMOS LSI.

1. When storing and transporting, thoroughly wrap them in aluminium foil. Also wrap all PW boards containing them in aluminium foil.
2. When soldering, ground the technician as shown in the figure and use grounded soldering iron and work table.

Component Teardown and Testing

Servicing of Touch Control Panel

The following are descriptions of the procedures to permit servicing of the touch control panel of the microwave oven and the precautions you must take when doing so. To perform the servicing, power to the touch control panel is available either from the power line of the oven itself or from an external power source.

1. Servicing the touch control panel with power supply of the oven:

CAUTION

The high voltage transformer of the microwave oven is still live during servicing and presents a hazard.

Therefore, before checking the performance of the touch control panel:

1. Disconnect the power supply cord and then remove outer case.
2. Open the door and block it open.
3. Discharge high voltage capacitor.
4. Disconnect the leads to the primary of the power transformer.
5. Ensure that these leads remain isolated from other components and oven chassis by using insulation tape.
6. After that procedure, re-connect the power supply cord.

After checking performance of touch control panel:

1. Disconnect the power supply cord.
 2. Open the door and block it open.
 3. Re-connect the leads to the primary of the power transformer.
 4. Re-install the outer case (cabinet).
 5. Re-connect the power supply cord after the outer case is installed.
 6. Run the oven and check all functions.
- a) On some models, the power supply cord between the touch control panel and the oven itself is so short that the two can't be separated. For those models, check and repair all the controls (sensor-related ones included) of the touch control panel while keeping it connected to the oven.

- b) On some models, the power supply cord between the touch control panel and the oven proper is long enough that they may be separated from each other. For those models, it is possible to check and repair the controls of the touch control panel while keeping it apart from the oven proper; in this case you must short both ends of the door sensing switch (on PWB) of the touch control panel with a jumper, which activates an operational state that is equivalent to the oven door being closed. As for the sensor-related controls of the touch control panel, checking them is possible if dummy resistor(s) with resistance equal to that of the controls are used.

2. Servicing the touch control panel with power supply from an external power source:

Disconnect the touch control panel completely from the oven proper, and short both ends of the door sensing switch (on PWB) of the touch control panel, which brings about an operational state that is equivalent to the oven door being closed. Connect an external power source to the power input terminal of the touch control panel, then it is possible to check and repair the controls of the touch control panel; it is also possible to check the sensor-related controls of the touch control panel by using the dummy resistor(s).

Servicing Tools

Tools required to service the touch control panel assembly.

1. Soldering iron: 60W (It is recommended to use a soldering iron with a grounding terminal.)
2. Oscilloscope: Single beam, frequency range: DC - 10MHz type or more advanced model.
3. Others: Hand tools

Other Precautions

1. Before turning on the power source of the control unit, remove the aluminium foil applied for preventing static electricity.
2. Connect the connectors of the key unit to the control unit being sure that the lead wires are not twisted.
3. After aluminium foil is removed, be careful that abnormal voltage due to static electricity etc. is not applied to the input or output terminals.
4. Attach connectors, electrolytic capacitors, etc. to PWB, making sure that all connections are tight.
5. Be sure to use specified components where high precision is required.

Component Teardown and Testing

Panel Sub Assembly And Control Unit Removal

1. Disconnect the power supply cord.
2. Open the door and block it open.
3. Remove the hood louver from the oven.
4. Remove one (1) screw holding the panel sub assembly to the oven cavity front face plate.
5. Release the panel sub assembly from the oven cavity front face plate by lifting it up.
6. Disconnect the wire leads from the relays RY1 and RY2.
7. Disconnect the connectors CN-A, CN-B, CN-C, CN-E, CN-F and CN-G from the control unit.
8. Remove the panel sub assembly from the oven.
9. Now, the panel sub assembly is free.
10. Remove two (2) screws holding the control unit to the panel sub assembly.
11. By releasing the tabs from the control unit, remove the control unit from the panel sub. assembly.
12. Now, the control unit is free.

Door Sensing Switch / Secondary Interlock Switch And Monitor Switch Removal

1. Disconnect the power cord and remove outer case.
2. Open the door and block it open.
3. Discharge high voltage capacitor.

CAUTION

To discharge the high voltage capacitor, wait for 60 seconds and then short-circuit the connection of the high-voltage capacitor (that is the connecting lead of the high-voltage rectifier) against the chassis with the use of an insulated screwdriver.

4. Remove the control panel assembly, referring to the procedure of "Control Panel Assembly, Control Unit And Key Unit Removal".
5. Remove the two (2) screws holding the latch hook to the oven cavity front flange.
6. Remove latch hook from the oven cavity front flange.
7. Disconnect the wire leads of each switch.
8. Remove each switch from the latch hook by pushing the one (1) stopper tub holding each switch.
9. Now, each switch is free..

Re-install

1. Re-install each switch in its place. The secondary interlock switch is in the lower position, door sensing switch is in the upper position and the monitor switch is in the middle position.
2. Re-connect wire leads to each switch. Refer to pictorial diagram.
3. Secure latch hook with two (2) mounting screws to oven flange.
4. Make sure that the monitor switch is operating properly and check continuity of the monitor circuit.

Component Teardown and Testing

Door Sensing Switch / Secondary Interlock Switch And Monitor Switch Adjustment

1. Disconnect power cord and remove outer case.
2. Open the door and block it open.
3. Discharge high voltage capacitor.

⚠ CAUTION

To discharge the high voltage capacitor, wait for 60 seconds and then short-circuit the connection of the high-voltage capacitor (that is the connecting lead of the high-voltage rectifier) against the chassis with the use of an insulated screwdriver.

4. Remove the right panel assembly, referring to the procedure of "Right Panel Assembly And Power Unit Removal".

If the door sensing switch, secondary interlock switch and monitor switch do not operate properly due to a misadjustment, the following adjustment should be made.

5. Loosen the two (2) screws holding latch hook to the oven cavity front flange.
6. With door closed, adjust latch hook by moving it back and forth, and up and down. In and out play of the door allowed by the upper and lower position of the latch hook should be less than 0.5mm. The vertical position of the latch hook should be adjusted so that the door sensing switch, secondary interlock switch are activated with the door closed. The horizontal position of the latch hook should be adjusted so that the monitor switch is activated with the door closed.
7. Secure the screws with washers firmly.
8. Check all of the switches operation. If any switch has not activated with the door closed, loosen screw and adjust the latch hook position.

After adjustment, check the following:

1. In and out play of door remains less than 0.5mm when in the latched position. First check upper position of latch hook, pushing and pulling upper portion of door toward the oven face. Then check lower portion of the latch hook, pushing and pulling upper portion of door toward the oven face. Both results (play in the door) should be less than 0.5mm.
2. The door sensing switch, primary switch and third door switch interrupt the circuit before the door can be opened.
3. Monitor switch contacts close when door is opened.
4. Re-install outer case and check for microwave leakage around door with an approved microwave survey meter.

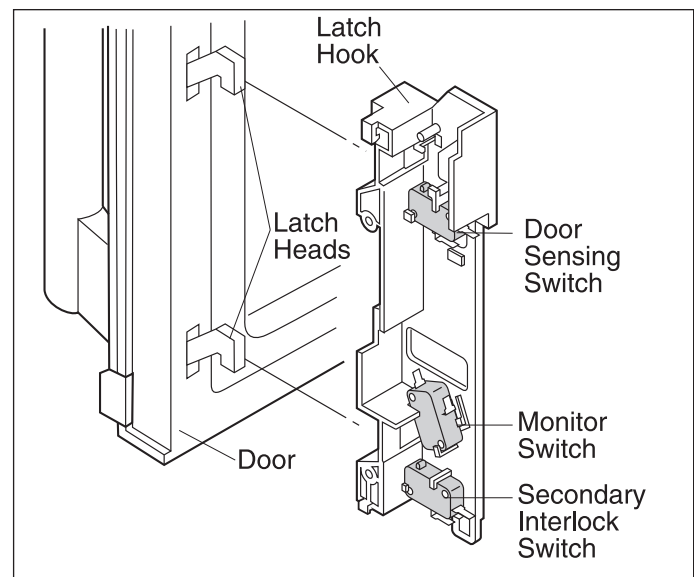

Figure 4-7. Latch Switch Adjustments

Component Teardown and Testing

Door Replacement

Removal

1. from wall and remove outer case. (Refer to procedure of “Removal of Oven from Wall” and “Outer case Removal”)
2. Open the door and block it open.
3. Discharge high voltage capacitor.

⚠ CAUTION

To discharge the high voltage capacitor, wait for 60 seconds and then short-circuit the connection of the high-voltage capacitor (that is the connecting lead of the high-voltage rectifier) against the chassis with the use of an insulated screwdriver.

4. Remove the hood louver from the oven. (Refer to the procedure of “Hood Louver Removal”.)
5. Insert a putty knife (thickness of about 0.5mm) into the gap A between the door stopper and the choke cover as shown in Figure 4-9 to free engaging parts.
6. Lift up the door stopper.
7. Now, the door stopper is free from the door assembly.
8. Lift up the door assembly to release the upper and lower door hinge pins from the upper and lower oven hinges.
9. Now, the door assembly is free.

NOTE: When the individual parts are replaced, refer to “Door Disassembly”.

Re-Install

1. On re-installing door, insert the lower oven hinge to lower door hinge pin.
2. Insert the upper oven hinge to the upper door hinge pin.
3. Shut the door (close the contacts of interlock switches).
4. Make sure upper and lower oven hinges are inserted into the upper and lower door hinge pins.
5. Make sure the door is parallel with oven face lines (left and upper side lines) and door latch heads pass through latch holes correctly.
6. Re-install the door stopper to the door assembly.
7. Re-install the hood louver to the oven cavity front face plate.

☰ NOTE

After any service to the door:

- (A) Make sure that door sensing switch, primary switch and secondary switch are operating properly.
- (B) An approved microwave survey meter should be used to assure compliance with proper microwave radiation emission limitation standards.

After any service, make sure of the following:

1. Door latch heads smoothly catch latch hook through latch holes and that latch head goes through center of latch hole.
2. Deviation of door alignment from horizontal line of cavity face plate is to be less than 1.0mm.
3. Door is positioned with its face pressed toward cavity face plate.
4. Check for microwave leakage around door with an approved microwave survey meter. (Refer to Microwave Measurement Procedure.)

☰ NOTE

The door on a microwave oven is designed to act as an electronic seal preventing the leakage of microwave energy from oven cavity during cook cycle. This function does not require that door be air-tight, moisture (condensation)-tight or light-tight. Therefore, occasional appearance of moisture, light or sensing of gentle warm air movement around oven door is not abnormal and do not of themselves indicate a leakage of microwave energy from oven cavity.

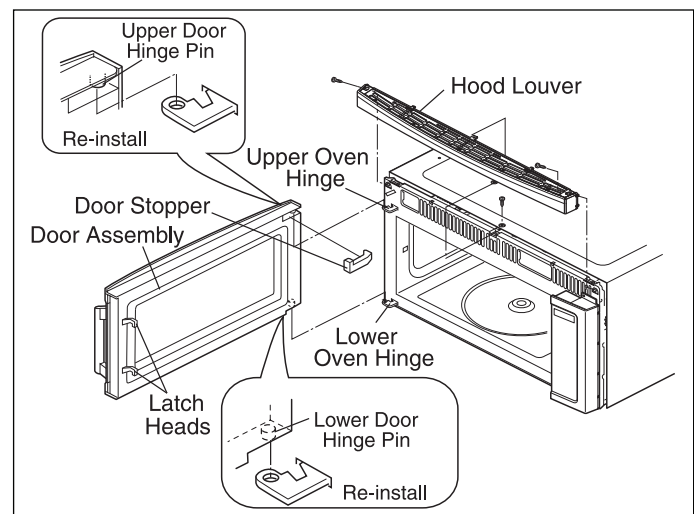

Figure 4-8. Choke Cover

Component Teardown and Testing

Door Disassembly

1. Disconnect the power supply cord and remove the oven from wall and remove outer case. (Refer to procedure of “Removal of Oven from Wall” and “Outer case Removal”)
2. Open the door and block it open.
3. Discharge high voltage capacitor.

⚠ CAUTION

To discharge the high voltage capacitor, wait for 60 seconds and then short-circuit the connection of the high-voltage capacitor (that is the connecting lead of the high-voltage rectifier) against the chassis with the use of an insulated screwdriver.

4. Remove the hood louver from the oven cavity. (Refer to the procedure of “Hood Louver Removal”.)
5. Remove door assembly, refer to “Door Replacement”. Replacement of door components are as follows:
6. Place door assembly on a soft cloth with latches facing up.

☰ NOTE

As the engaging part of choke cover and door frame are provided at 16 places, do not force any particular part.

CHOKE COVER

7. Insert a putty knife (thickness of about 0.5mm) into the gap A between the choke cover and door stopper and between the choke cover and the door frame as shown Figure 4-9 to free engaging parts.
8. Pry the choke cover by inserting a putty knife in order shown in Figure 4-9.
9. Now choke cover is free from door panel and door frame.

LATCH SPRING, LATCH HEAD AND DOOR PANEL

10. Release the latch spring from the tab of the latch head and tab of the door panel.
11. Release the latch head from the door panel.
12. Now, the latch spring, latch head and door panel are free.

DOOR FRAME

13. Remove eight (8) screws holding the door panel to the door frame assembly.
14. Release the door frame assembly from the door panel.

☰ NOTE

It is easier to release the engaging parts of the upper or lower door hinge pin side at first.

15. Now, door frame assembly is free.

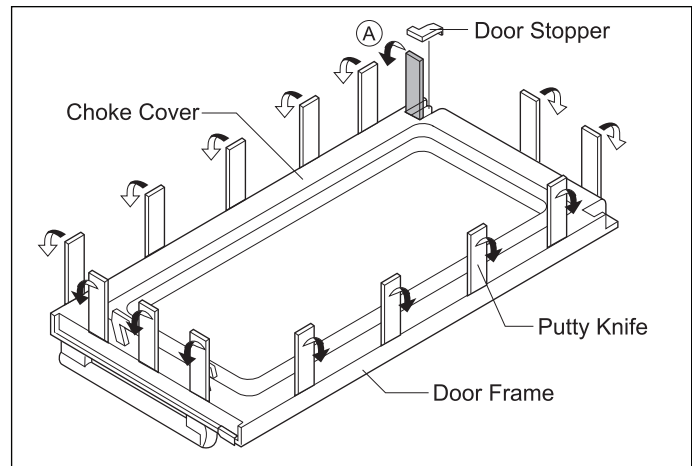
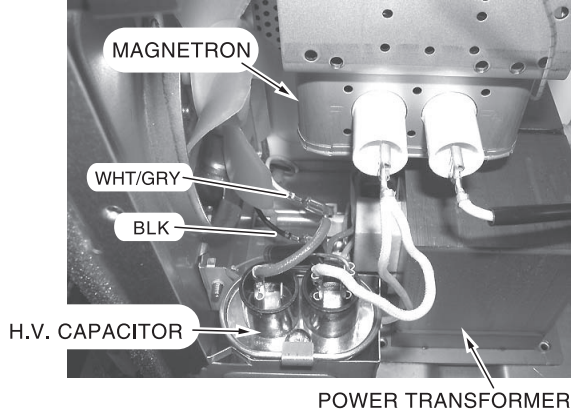
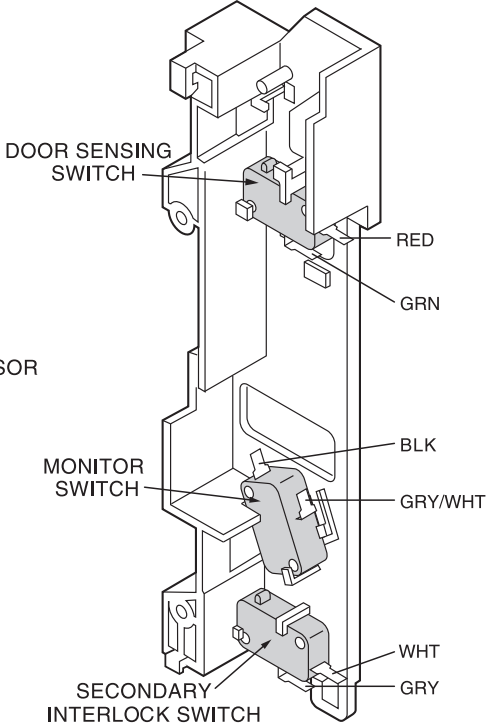
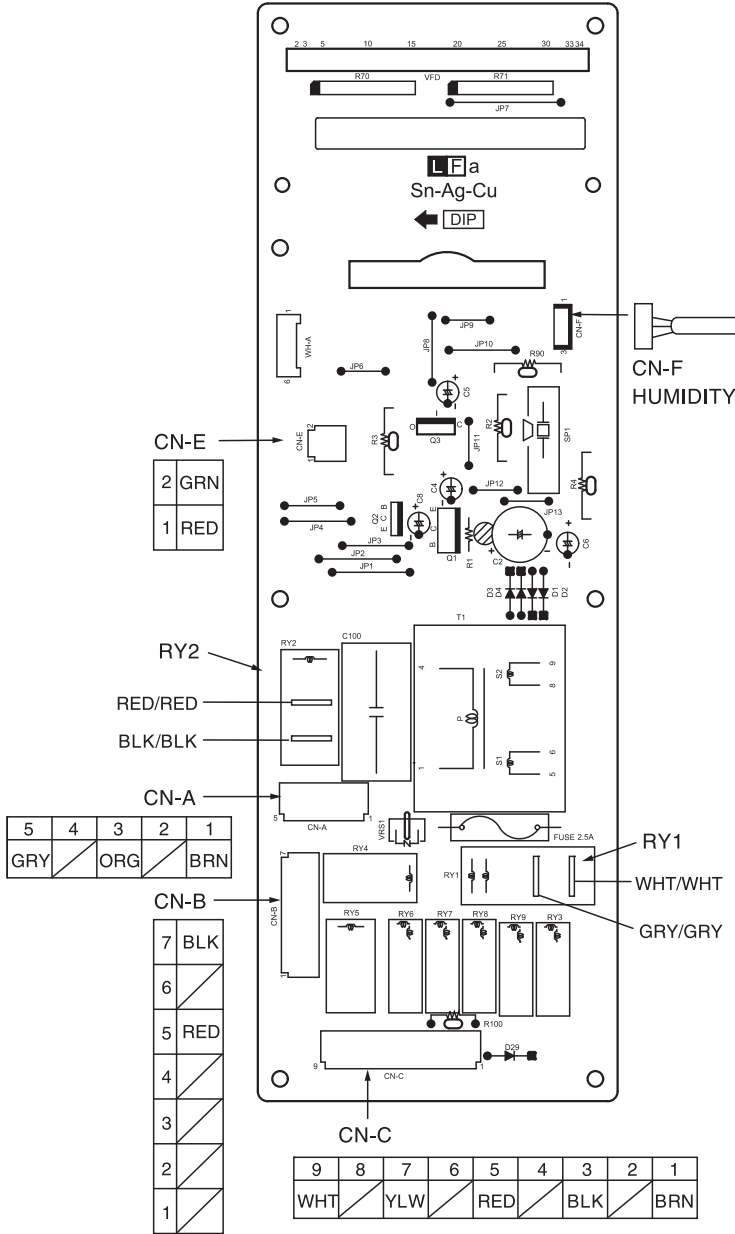

Figure 4-9. Choke Cover

Cook Top Lamp Socket Removal

1. Disconnect the power supply cord.
2. Remove the three (3) screws holding the deflector to the base cover.
3. Remove the one (1) screw holding the base cover to the oven cavity back plate.
4. Remove the four (4) screws holding the base cover to the outer case cabinet.
5. Remove the three (3) screws holding the base cover to the oven cavity base plate.
6. Pull down and slide to left the base cover. Then remove the base cover from the cavity back plate.
7. Remove the one (1) screw holding the lamp mounting angle.
8. Remove the lamp mounting angle from the oven cavity face plate.
9. Disconnect the wire leads from the lamp socket.
10. Remove the two (2) screws holding the lamp socket from the lamp mounting angle.
11. Now, the lamp socket is free.

Circuit Components



Wiring Diagrams

Glass Touch Key Unit Diagram

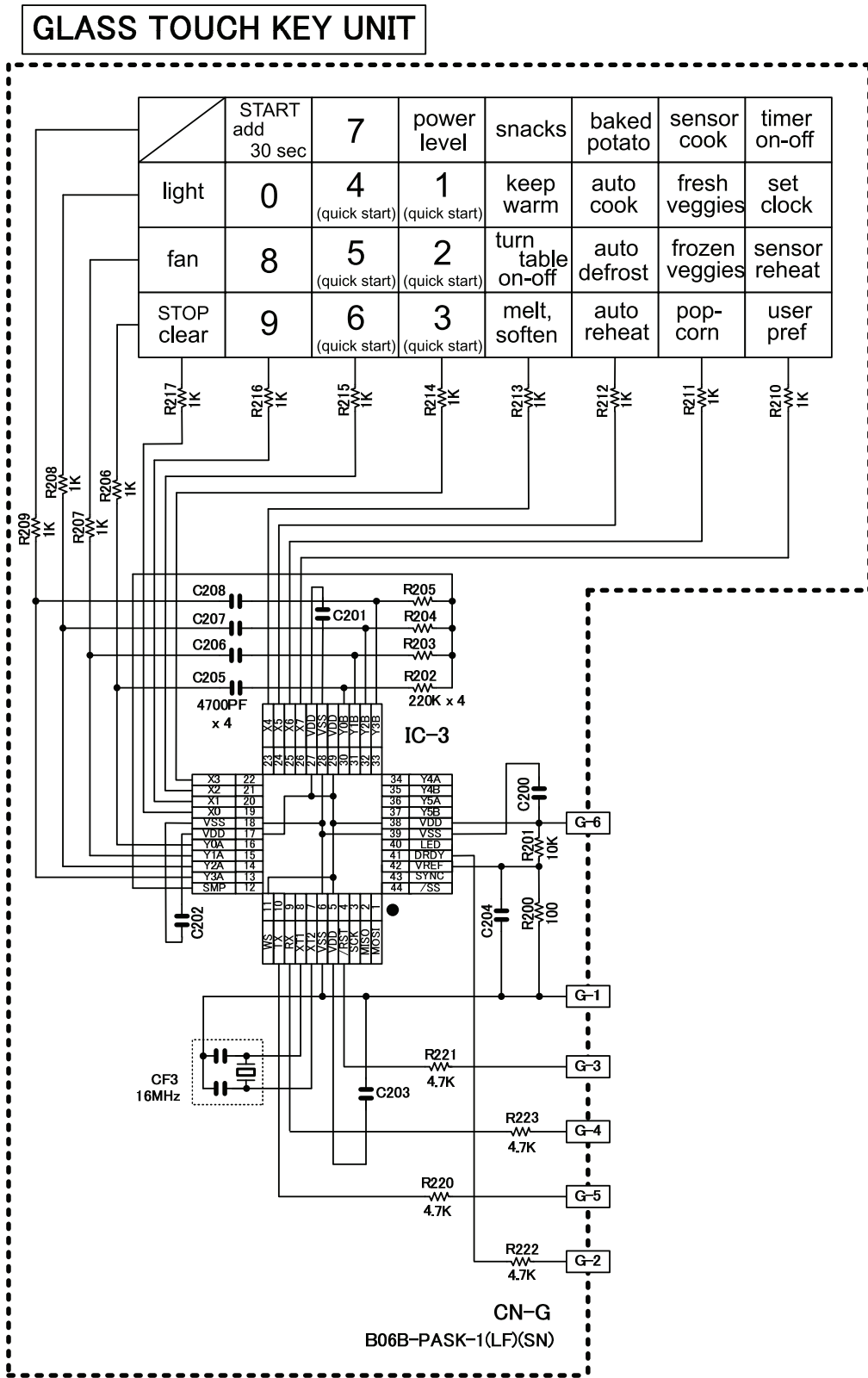

Control Unit Circuit

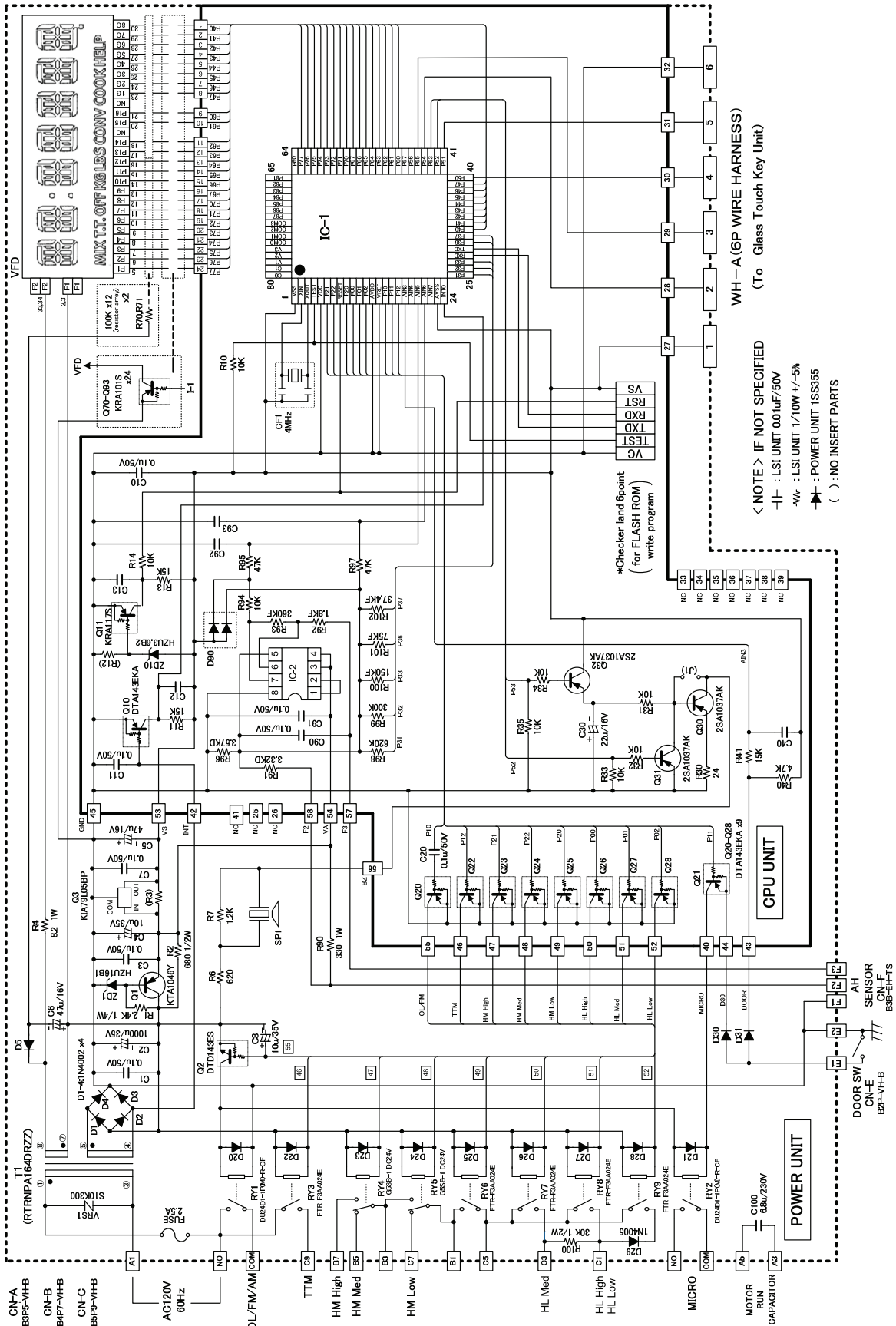

Wiring Diagrams

Oven Wiring Schematic Off Condition

SCHEMATIC

Note: Condition Of Oven

1. Door Closed.
2. Clock Appears On Display

NOTES:

1. Circuits subject to change without notice
2. The neutral wire(White or Gray wire) must be connected to the prescribed tab terminal of the lamp socket.
3. Only certain models use the humidity sensor.
4. The neutral wire(White/Gray wire) must be connected to the winding start tab terminal of the power transformer primary winding.

NOTE: "★" indicates components with potentials above 250V

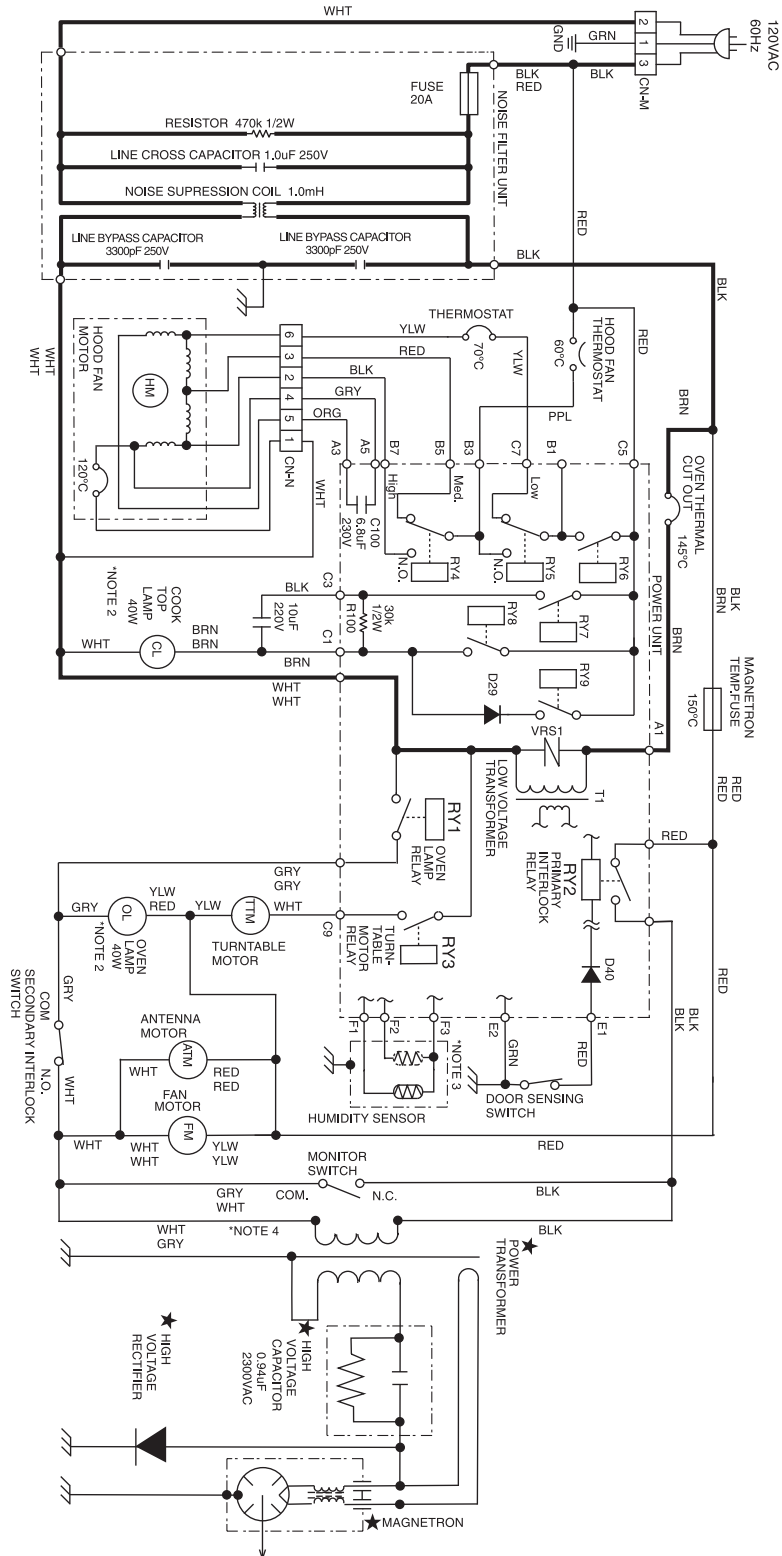

NOTE: Parts marked "*" may cause undue microwave exposure.
Parts marked "Δ" are used in voltage more than 250V.

NO.	DESCRIPTION	QTY
ELECTRIC PARTS		
Δ 1	H.V rectifier	1
Δ 2	HV capacitor	1
3	Turntable motor	1
4	Antenna motor	1
5	Thermal cut out 60°C (Hood fan)	1
* 6	Power transformer	1
*Δ 7	Magnetron	1
8	Secondary Interlock and door sensing switches	2
9	Monitor switch (D3V-1G-2C25) and use (20A 250V AC) assy	1
10	Power supply cord	1
11	Lamp socket	1
12	Hood motor assembly	1
13	Fan motor	1
14	Noise filter	1
15	Thermal cut out (Oven)	1
16	Humidity sensor assembly	1
17	DM 150V fuse (Magnetron)	1
18	Thermal cut out	1
19	Oven light (cook top lamp, oven lamp)	2
20	Lamp socket	1
21	Capacitor for cook top lamp	1
CABINET PARTS		
22	Schematic diagram	1
23	Lamp glass assembly	1
23-1	Hood lamp glass ag black	1
23-2	Lamp glass	1
24	Lamp mounting angle	1
25	Rear stay	1
26	Base cover	1
27	Lamp cover	1
28	Fan duct	1
29	Unit mounting plate	1
OVEN PARTS		
36	Damper assembly	1
37	Outer case cabinet	1
38	Turntable	1
39	HV. capacitor band	1
40	Stirrer cover	1
41	Stirrer antenna assembly	1
42	Roller assembly	1
43	TTM packing	1
44	Latch hook	1
45	Harness cover	1
46	Fan blade	1
47	Cord bushing	1
48	Hood louver assembly	1

NO.	DESCRIPTION	QTY
49	Hood intake duct R	1
50	Cushion	2
51	Lamp filter	1
52	Chassis support	2
53	Deflector	1
54	Hood duct	1
55	Rack holder	2
57	Barrier	1
58	HVT cushion	1
59	Cushion	1
60	Base plate right	1
61	Rack holder L	1
62	Rack holder R	1
75	Lamp heat cover	1
76	Accessory assembly	1
76-1	Grommet	1
76-2	Special screw	4
76-3	Machine screw	2
76-4	Tap tight screw	4
76-5	Tapping screw	6
76-6	Washer	2
77	Hood lamp reflector	1
78	Menu label	1
80	Cushion	1
81	Cushion	2
90	DHHS ground caution	1
91	Monitor caution	1
92	Filter	1
93	Mesh filter	2
94	Canoe clip	1
95	Rack	1
96	Filter	1
99	Cushion	1
117	DHHS caution	2
SCREWS, NUTS, WASHERS AND MISC.		
34	Screw; 3mm x 8mm	4
105	Screw; 4mm x 8mm	12

Parts List

NO.	DESCRIPTION	Q'TY
106	Screw; 3mm x 8mm	2
107	Screw; 4mm x 8mm	38
108	Screw; 4mm x 8mm	7
109	Screw; 4mm x 8mm	2
110	Screw; 4mm x 12mm	2
111	Screw; 4mm x 8mm	4
112	Screw; 4mm x 12mm	1
113	Screw; 3mm x 6mm	3
114	Special screw	2
DOOR AND CONTROL PANEL PARTS		
CONTROL PANEL PARTS		
30	Control unit	1
31	Panel sub assembly(with Glass touch key unit)	1
35	Screw; 3mm x 8mm	2
DOOR PARTS		
56	Door stopper	1
* 64	Door sub assembly	1
* 65	Door frame assembly	1
67	Handle cap low	1
* 68	Latch head	1
69	spring	1
70	Handle cap up	1
* 71	Choke cover	1
72	Sealer film	1
73	Handle	1
74	Door badge	1
100	Screw; 4mm x 8mm	8
101	Screw; 4mm x 30mm	2
102	Special screw	2
MISCELLANEOUS		
88	Earth wire	1
89	Main wire harness	1
116	Wire holder	1
PACKING AND ACCESSORIES		
36	Damper assembly	1
38	Turntable	1
76	Accessory assembly	1
82	Cushion	1
84	Installation inst	1
85	Instruction book	1
86	Top template	1
87	Wall template	1
93	Mesh filter	2
95	Rack	1
118	Information	1

Oven And Cabinet Parts

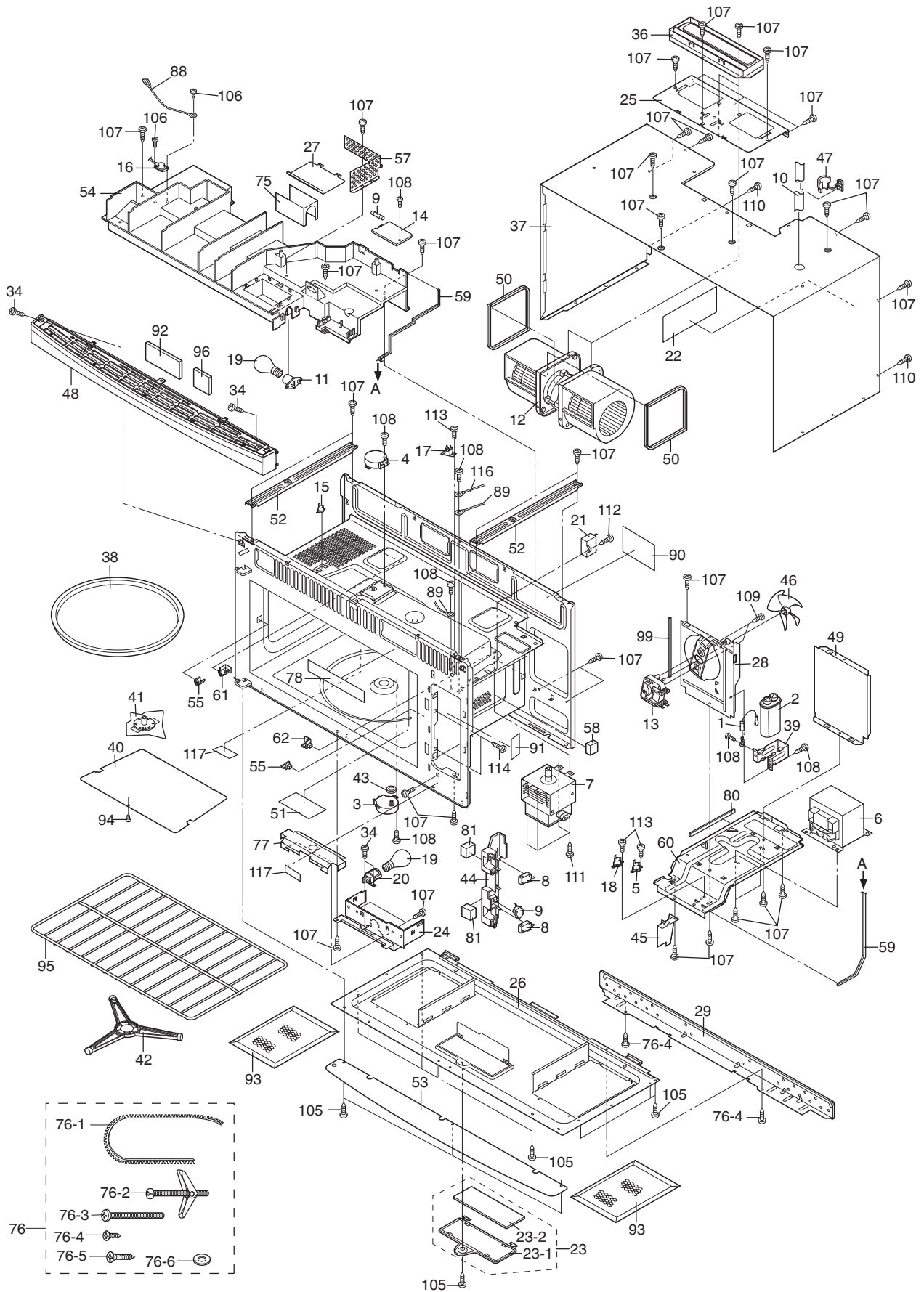

Parts List

Door Assembly and Control Unit

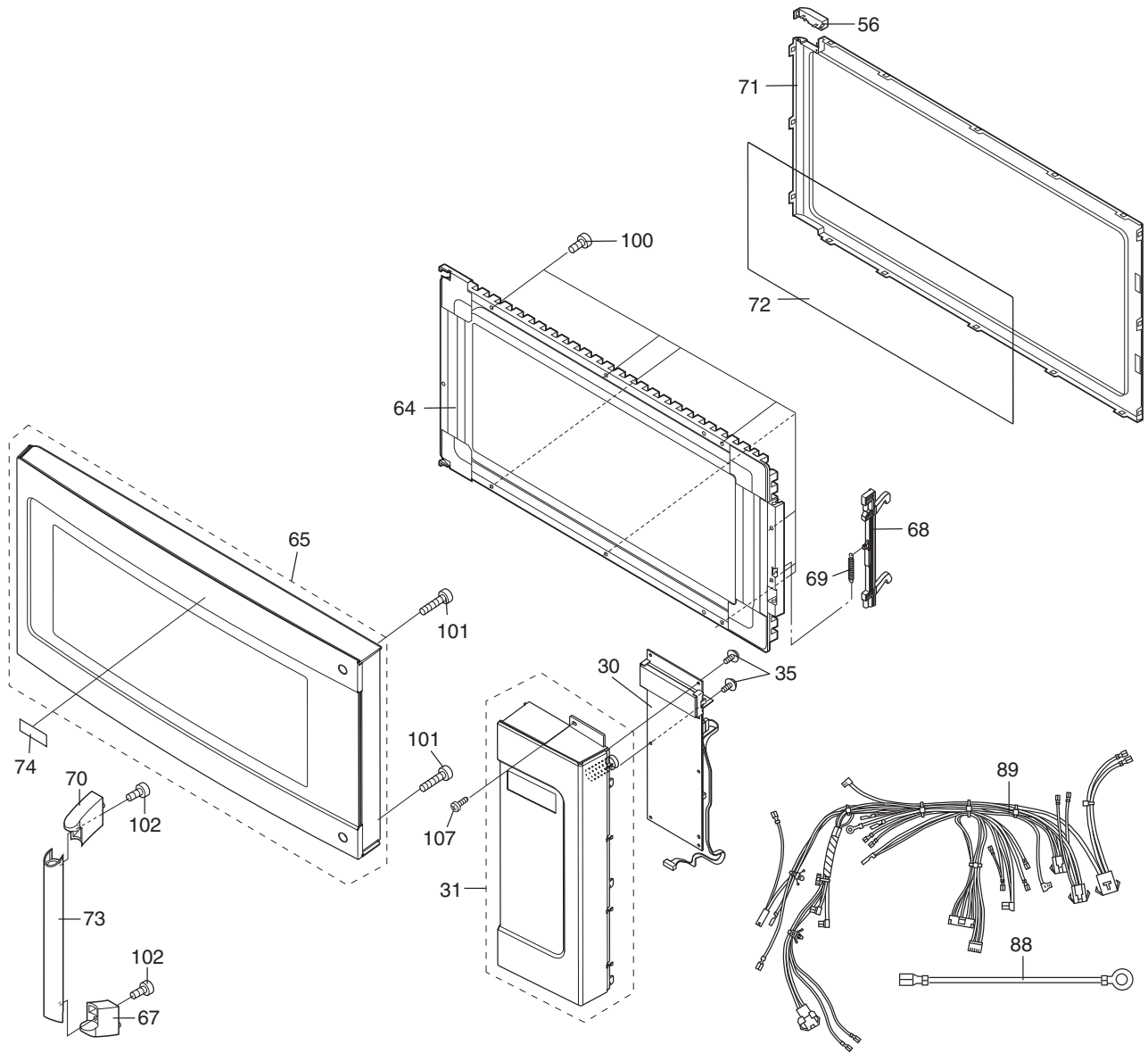

Packing And Accessories

