

# Free Standing Gas Range Updates

Higher grade features moved further down in the product line for added consumer value.

- Deep Recessed Cooktops
- Heavy Cast Continuous Grates
- Five Burner Configuration
- Reversible Cast Iron Griddle/Grill
- Curved Control Panel and Door
- New Precise Broil Burner
- Baking Drawer



imagination at work

## **IMPORTANT SAFETY NOTICE**

The information in this presentation is intended for use by individuals possessing adequate backgrounds of electrical, electronic, & mechanical experience. Any attempt to repair a major appliance may result in personal injury & property damage. The manufacturer or seller cannot be responsible for the interpretation of this information, nor can it assume any liability in connection with its use.

### **WARNING**

To avoid personal injury, disconnect power before servicing this product. If electrical power is required for diagnosis or test purposes, disconnect the power immediately after performing the necessary checks.

### **RECONNECT ALL GROUNDING DEVICES**

If grounding wires, screws, straps, clips, nuts, or washers used to complete a path to ground are removed for service, they must be returned to their original position & properly fastened.

**GE Factory Service Employees are required to use safety glasses with side shields, cut resistant (Dyneema®) gloves & steel toe shoes for all repairs.**



**Dyneema® Cut Resistant Glove**



**Steel Toe Shoes**



**Plano Safety Glasses**

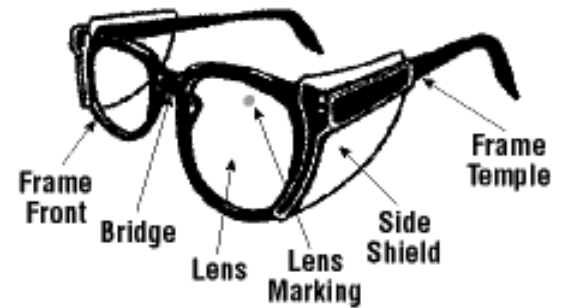

**Prescription Safety Glasses**

**Safety Glasses must be compliant with ANSI Z87.1-2003**

## GE® Free-Standing Gas Ranges – New Product Introductions

Today's consumers are looking for the best value for their dollar. To address this consumer need we have launched six new GE® branded ranges that offer great value high-end features.

All six have a deep recessed cook top, new cast iron grates, improved appearance and now offer three 5-burner cook top configurations.

These new models have an estimated retail price starting at \$799\* in color. At the top end, the new JB900 delivers most of the features found on our most expensive Profile gas range model, but for hundreds of dollars below the estimated retail price\* of the Profile model.



Check out the significant feature upgrades of our new free-standing gas ranges that are sure to appeal to today's consumers.

\* All resellers determine their own retail selling prices.

# Features of our Newest GE® Free-Standing Gas Ranges:

## Deep recessed cooktops

All 6 new models have the deep-recessed cooktop, which helps contain spills for easy cleaning. The JB900 features an **all stainless steel cooktop**.



## Heavy-cast Continuous Grates

New, **heavy-cast, continuous cooktop grates** provide a sturdy, uninterrupted cooking surface, and the **black matt finish** is standard for all colors and looks "grate".



## Five-burner configuration

The **center round burner** provides flexibility to accommodate virtually all your cooking needs, and the 5,000 BTU burner turns down to 140°. Available on JGB400 model.

A **high power 10,000 BTU center oval burner** is available on 3 of our new models - [JGB800](#), [JGB820](#) and [JGB900](#).

# Features of our Newest GE® Free-Standing Gas Ranges:



## Reversible Cast Iron Griddle/Grill

Double your options with the **reversible cast-iron griddle/grill**. Placed over a fifth 10,000 BTU center oval burner, one side provides a flat surface for cooking and warming all types of food. On the other side, the ribbed design is ideal for searing meats at high temperatures. The griddle/grill is removable for easy cleaning.



## Curved control panel and door

All new models contain the curved door to match the curved manifold. The top of the door matches the manifold, while the bottom of the door is flat to match the drawer, giving a stunning appearance.

## Two of our "grate" new models

### GE 30" range JGB900

- Self-clean oven
- Super-large 5.0 cu. ft. oven capacity
- Gas convection oven
- **Baking drawer**
- **Stainless steel deep-recessed cooktop**
- Heavy-cast continuous grates\*
- Reversible cast-iron griddle/grill
- PowerBoil™ 17,000 BTU burner
- Colors available: SS



High End

### GE 30" range JGB400

- Self-clean oven
- Super-large 5.0 cu. ft. oven capacity
- Deep-recessed cooktop
- Heavy-cast continuous grates\*
- **Center round burner**
- **PowerBoil 16,500 BTU burner**
- Precise Simmer burner
- TrueTemp™ oven system
- Colors available: SS, WW, BB



Low End

# Overview-Features

- Upgrade all GE FSG mid to high end models
- New base model numbering sequence...300-400-500 etc

Deep Recess  
Cook top w/ Continuous  
grates  
**Starting \$799\***



CU Broil / Bake  
improvements  
**All price points**



GE curve door &  
matching curve Cook top  
**Starting \$799\***



Round 5<sup>th</sup> Burner  
**Starting \$899\***



High output oval w/  
reversible cast  
iron griddle  
**Starting \$1,199\***



Feature Migration

- Burners BTU
- Gas Convection
- SS cook top

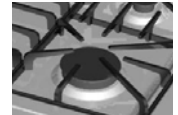

**\*Retailers establish their own pricing**



# Overview-Feature Detail

## New Curved Door

SS – New Door skin

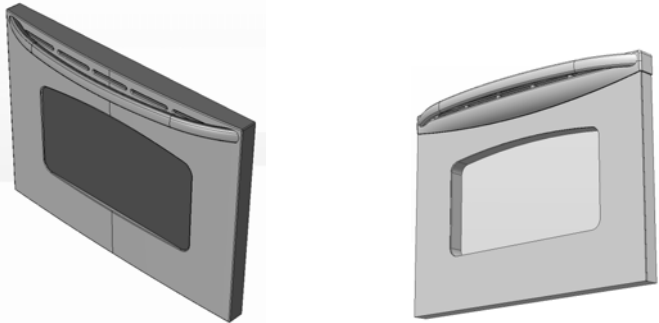

← Current →



# Overview-Feature Detail

## Center High Output Burner & Griddle

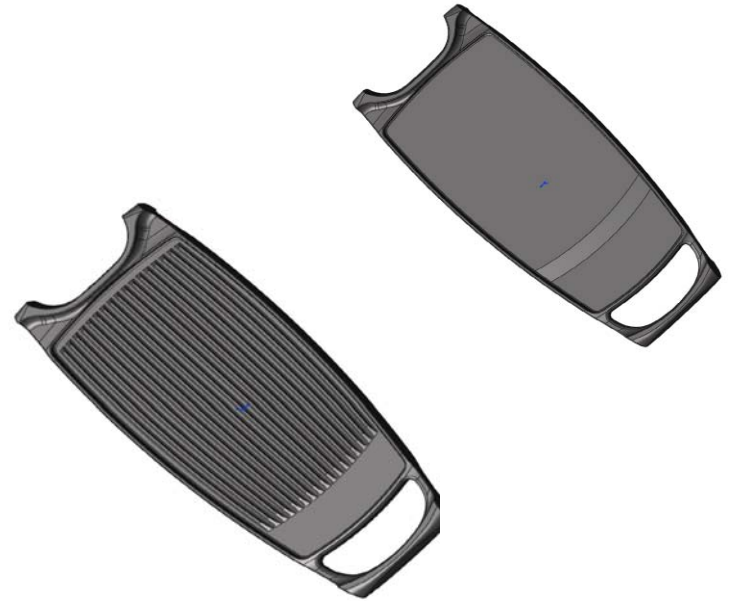
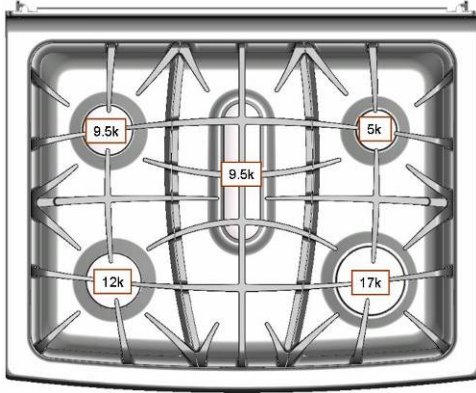

- 10 K BTU (current 6K)
- Current Al. Teflon griddle temp limited to ~450 F
- Move to pre-seasoned cast iron
- Allows 550+ F searing
- Starting \$ 1199 / \$ 1449\* SS price point (current \$1099)

\*Retailers establish their own pricing

## Using the griddle. *(on some models)*

---



Your nonstick coated griddle provides an extra-large cooking surface for meats, pancakes or other food usually prepared in a frying pan or skillet.

The ribbed side of the griddle is designed to lift your food away from oil and fat while grilling your food.

**NOTE:** *Your griddle will discolor over time as it becomes seasoned with use.*

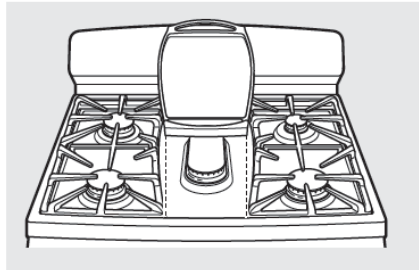

### **How to Insert the Griddle**

**⚠ CAUTION:** *Place and remove the griddle only when all grates and griddle are cool and all surface units are turned OFF.*

The griddle can only be used with the center burner. To insert the griddle, remove the center grate and replace with the griddle.

For best performance the griddle should be pre-heated before use.

# Overview-Feature Detail

## Broil Burner Shield

Allows for more consistent (Precise) broiling.

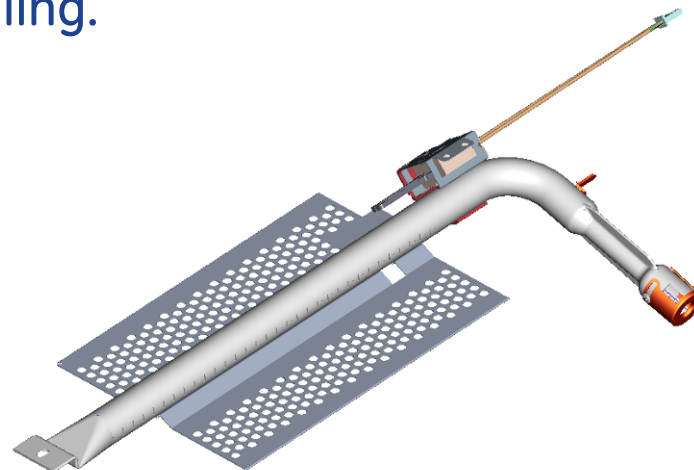
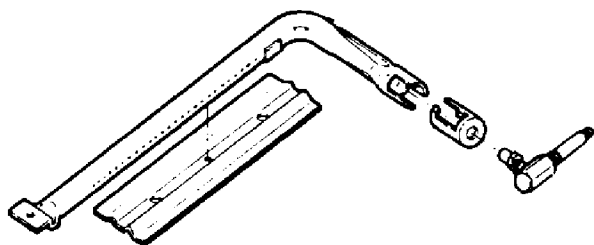

55%



84%

# Overview-Feature Detail

## Broil Burner Shield

The broil shield attaches to the burner with two ¼" hex head screws and can not be added to older burner types.



# Overview-Feature Detail

## Lower Oven – Baking Drawer

The lower oven operates off of two 120 volt elements, 412 watt upper and 800 watt lower. The thermostat cycles the elements together. The line wire feeds through the main oven self clean latch so the drawer can not be used during the clean cycle. Due to the wattage; it is recommended that the baking drawer is pre-heated before use.

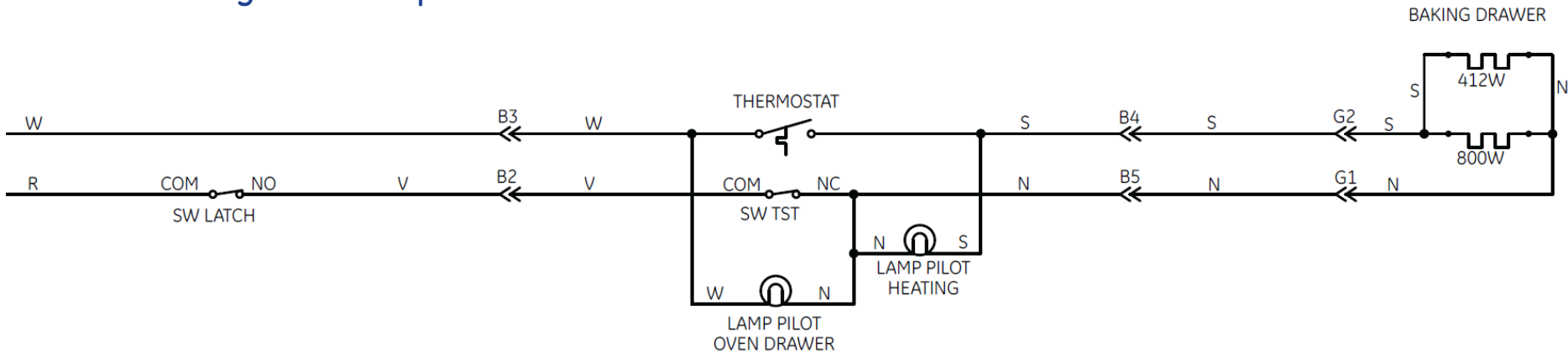

The lower oven drawer uses less energy than the upper oven.  
Allow the following approximate times for preheating:

Desired Lower Oven Temperature	Preheat Time
<b>WARM</b>	10 minutes
<b>350°F</b>	20 minutes
<b>425°F</b>	30 minutes

# Baking Drawer Removal

The lower drawer can be removed by pulling the drawer straight out until it stops, pressing the tabs firmly inward on both sides of the drawer rails and pulling the drawer forward until disengaged from the drawer guides.

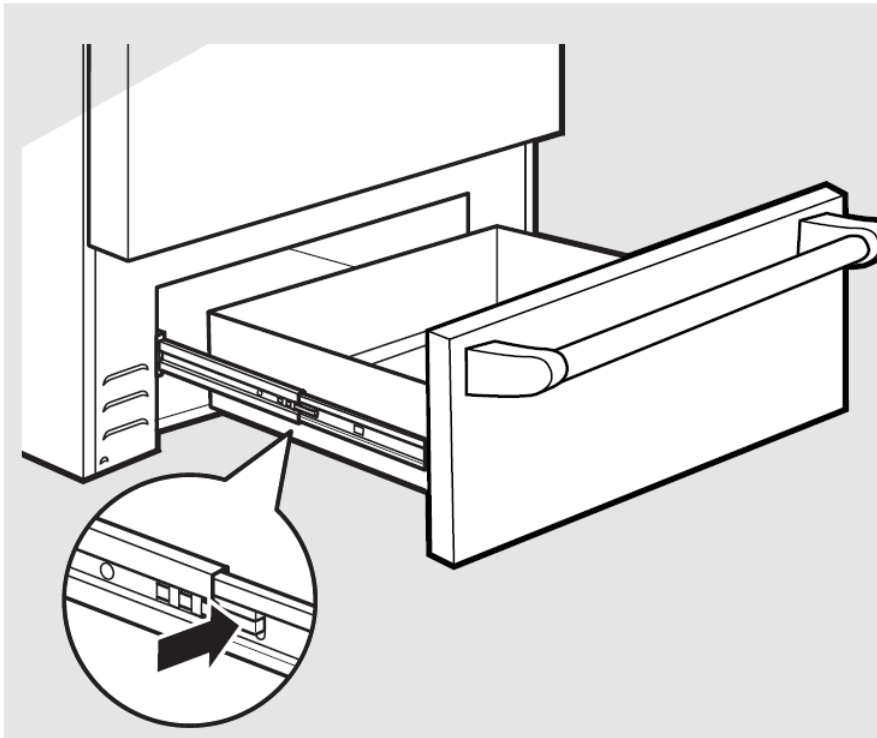

The lower drawer can be installed by placing each drawer rail around each inner rail guide and sliding both in slightly to hook them, then firmly sliding the drawer all the way in.

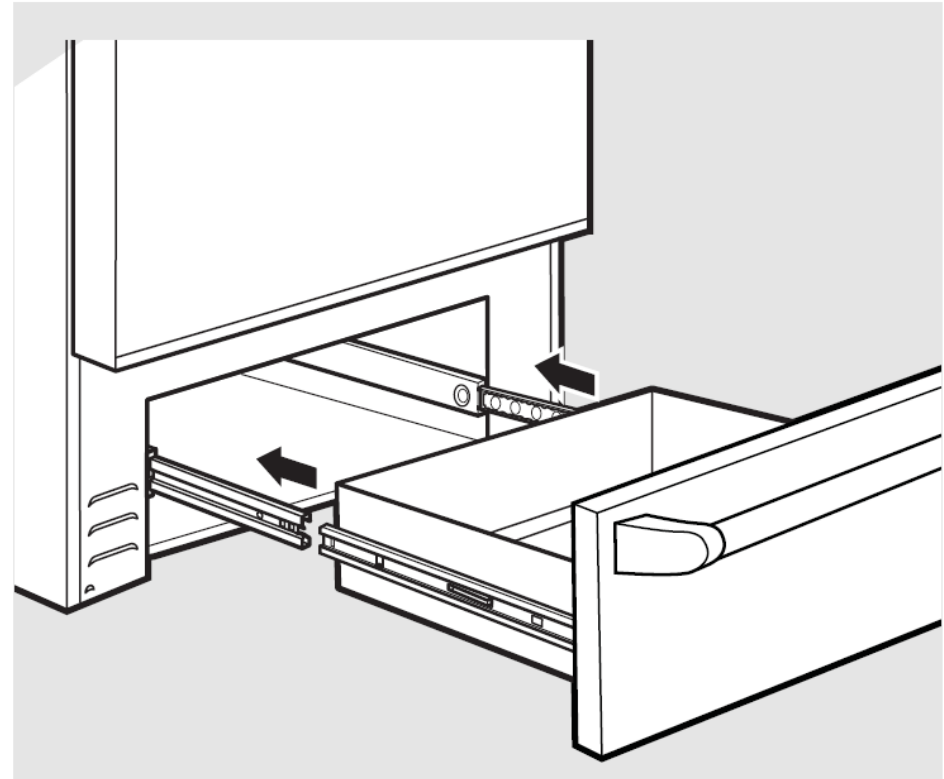

# Overview-Feature Detail

## Lower Oven – Baking Drawer

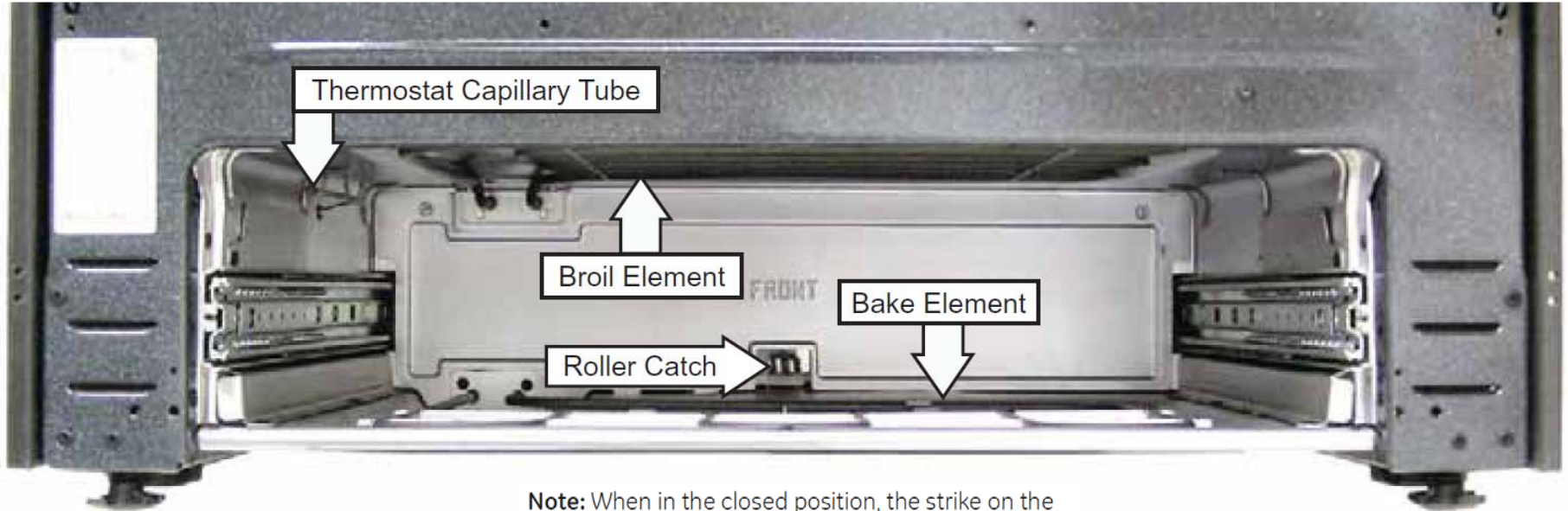

**Note:** When in the closed position, the strike on the back of the drawer is captured by the roller catch. The strike is riveted in place and is not adjustable. The roller catch is attached to the range floor with two 1/4-in. hex-head screws that, when loosened, can provide a small amount of adjustment.

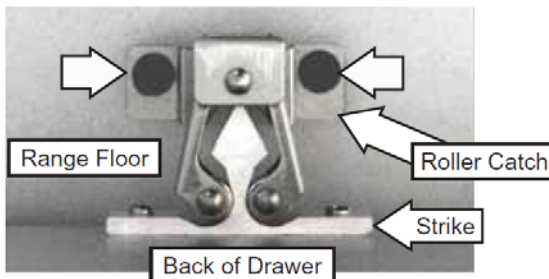



## Lower Oven Bottom Element

### To remove the lower oven bottom element:

1. Remove the lower oven drawer. (See **Lower Oven Drawer**.)
2. Remove the 2 slotted screws and the oven rear panel.

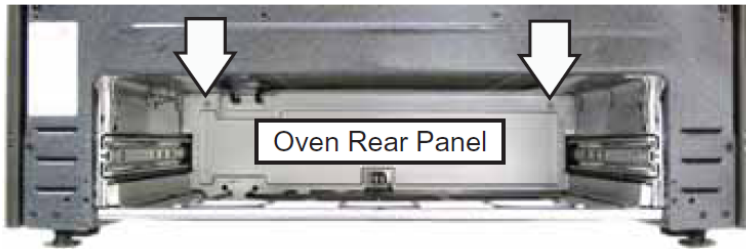

3. Remove the two 1/4-in. hex-head screws that attach the bottom element terminal cover. Place cover aside.

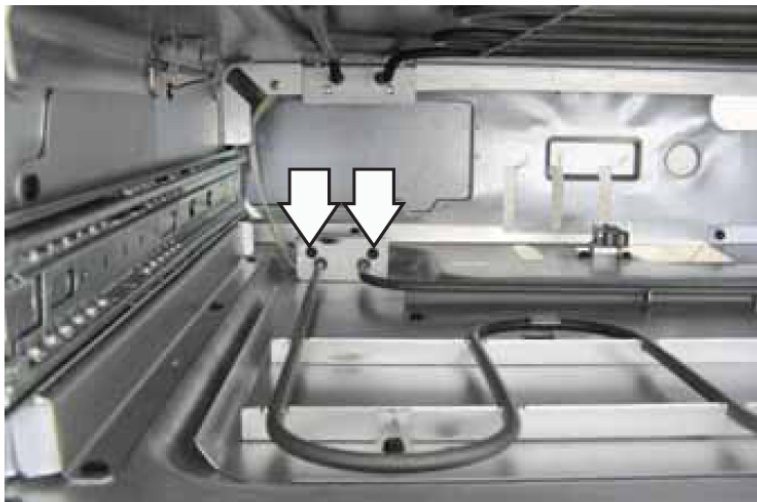

4. Reach behind the element and pull off the 2 element wire connectors.
5. Remove the two 1/4-in. hex-head screws that attach the element to the oven floor.

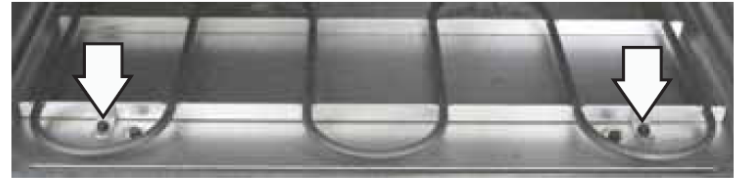

6. Remove element from the oven.

**Note:** When installing the element, be sure to place element under the 3 retainers before installing element-to-floor screws.



## Lower Oven Top Element

### To remove the lower oven top element:

1. Remove the lower oven drawer. (See *Lower Oven Drawer*.)
2. Remove the 2 slotted screws and the oven rear panel. (See *Lower Oven Bake Element*.)
3. Remove the two 1/4-in. hex-head screws that attach the top element terminal cover. Place cover aside.



4. Reach behind the element and pull off the 2 element wire connectors.
5. Remove the six 1/4-in. hex-head screws that attach the top element to the oven ceiling.



## Lower Oven Control

### To remove the lower oven control:

1. Remove the rangetop.
2. Remove the lower oven control knob.
3. Remove the 2 Phillips-head screws and the control from the control panel.

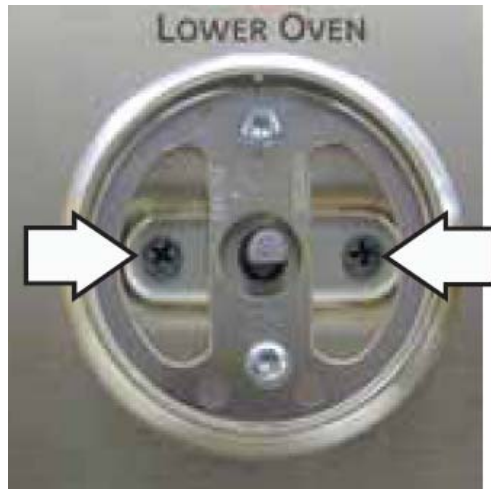

4. Mark and remove the wires from the control.
5. Push up and release the capillary bulb from each capillary bulb clip.

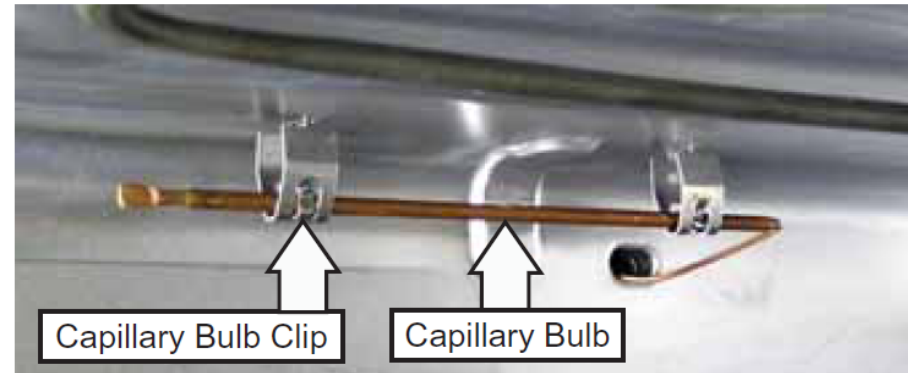

6. Squeeze and remove the capillary bulb clips and remove them from the holes in the oven ceiling.

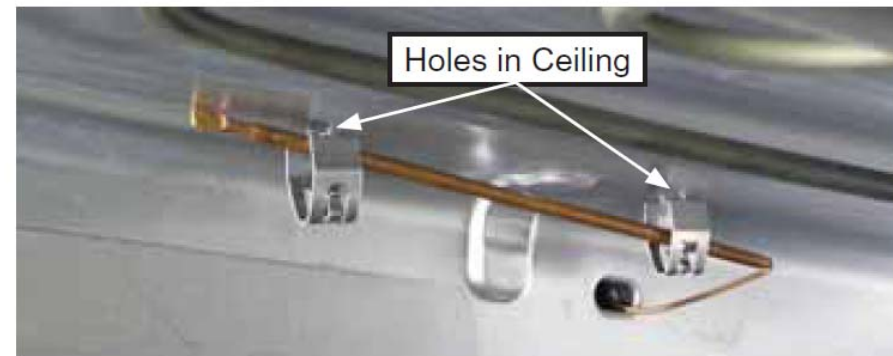

7. Remove the 4 Phillips-head screws and the locator pin from the top of the left side panel.
8. Remove the six 1/4-in. hex-head screws from the back of the left side panel.
9. Carefully spread the rear of the left side panel out from the range approximately 10 inches.
10. Push the capillary bulb through the entry hole while pulling the capillary from the range.



# Spark Module

The spark module is accessed from the rear of the range. The module has two snap clips that attach it to the rear access panel.

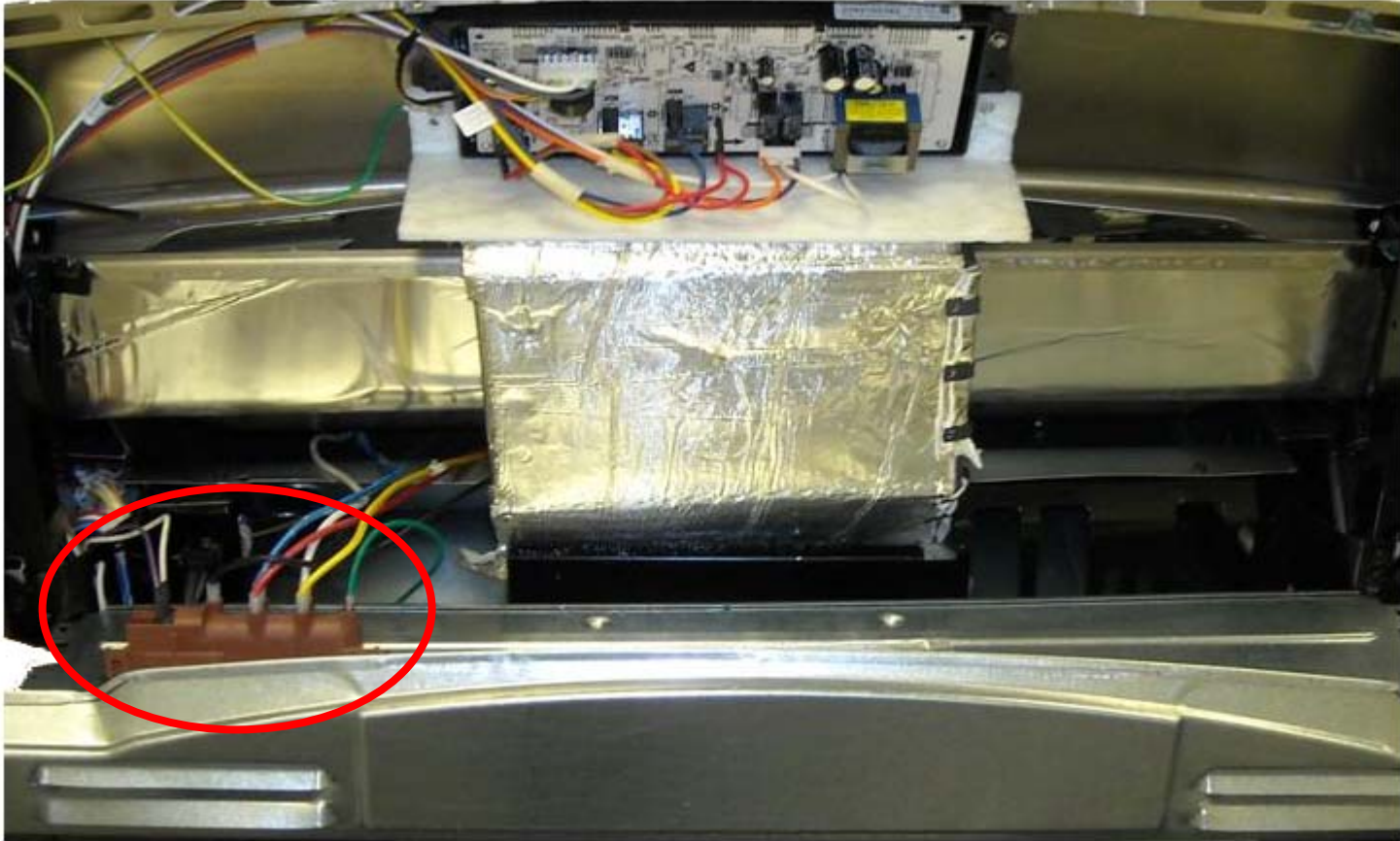

# Wiring Diagram

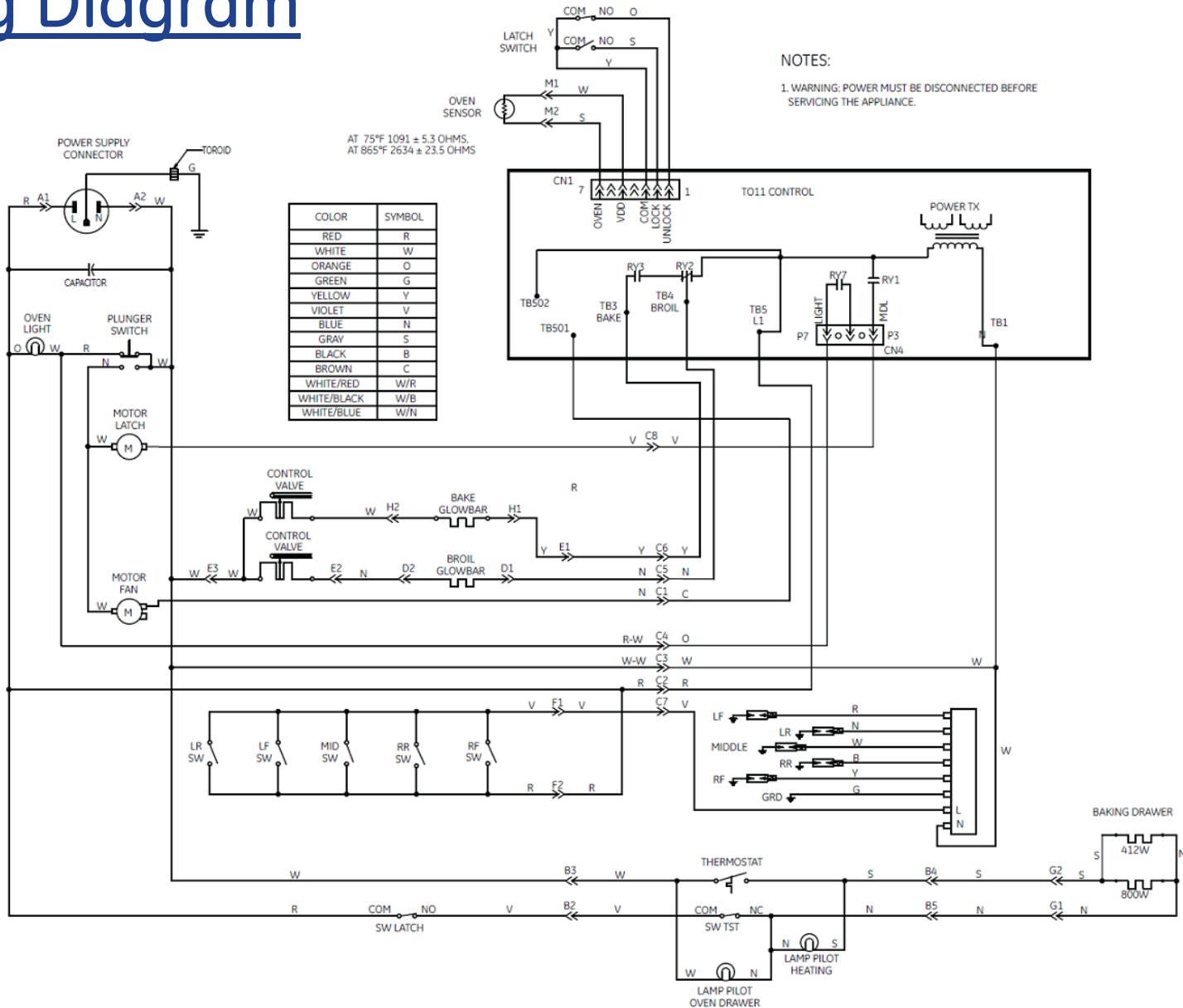

# GE Gas Range Warranty. *(For customers in the United States)*



All warranty service provided by our Factory Service Centers, or an authorized Customer Care® technician. To schedule service, visit us on-line at [GEAppliances.com](http://GEAppliances.com), or call 800.GE.CARES (800.432.2737). Please have serial number and model number available when calling for service.

Staple your receipt here.  
Proof of the original purchase date is needed to obtain service under the warranty.

## For The Period Of: GE Will Replace:

**One Year**  
From the date of the original purchase

**Any part** of the range which fails due to a defect in materials or workmanship. During this **limited one-year warranty**, GE will also provide, **free of charge**, all labor and in-home service to replace the defective part.

## What GE Will Not Cover:

- Service trips to your home to teach you how to use the product.
- Improper installation, delivery or maintenance.
- Failure of the product if it is abused, misused, or used for other than the intended purpose or used commercially.
- Replacement of house fuses or resetting of circuit breakers.
- Damage to the product caused by accident, fire, floods or acts of God.
- Incidental or consequential damage caused by possible defects with this appliance.
- Damage caused after delivery.
- Product not accessible to provide required service.