

Service

This manual is to be used by qualified appliance technicians only. Maytag does not assume any responsibility for property damage or personal injury for improper service procedures performed by an unqualified person.

Fully Electronic Radiant Cooktops

This Base Manual covers general information
Refer to individual Technical Sheet
for information on specific models

This manual includes, but is
not limited to the following:

JEC0530ADB/S/W
JEC0536ADB/S/W

Important Information

Pride and workmanship go into every product to provide our customers with quality products. It is possible, however, that during its lifetime a product may require service. Products should be serviced only by a qualified service technician who is familiar with the safety procedures required in the repair and who is equipped with the proper tools, parts, testing instruments and the appropriate service information. **IT IS THE TECHNICIANS RESPONSIBILITY TO REVIEW ALL APPROPRIATE SERVICE INFORMATION BEFORE BEGINNING REPAIRS.**

Important Notices for Servicers and Consumers



WARNING

To avoid risk of severe personal injury or death, disconnect power before working/servicing on appliance to avoid electrical shock.

To locate an authorized servicer, please consult your telephone book or the dealer from whom you purchased this product. For further assistance, please contact:

Customer Service Support Center

CAIR Center

<u>Web Site</u>	<u>Telephone Number</u>
WWW.JENNAIR.COM	1-800-536-6247
CAIR Center in Canada	1-800-688-2002

Recognize Safety Symbols, Words, and Labels



DANGER

DANGER—Immediate hazards which **WILL** result in severe personal injury or death.



WARNING

WARNING—Hazards or unsafe practices which **COULD** result in severe personal injury or death.



CAUTION

CAUTION—Hazards or unsafe practices which **COULD** result in minor personal injury, product or property damage.

Table of Contents

Important Information	2	Troubleshooting Procedures	
Safety Information	4	Electronic Touch Control Troubleshooting	10
Safety Practices for Servicer	5	Component Troubleshooting	11
Servicing	5	Testing Procedures	
Before Installing	5	Component Testing	13
Receiving Cooktop	5	Disassembly Procedures	
Unpacking	5	Main Top Removal	15
Electrical Requirements	5	Element Replacement	15
Extension Cords	5	Sensor Replacement	15
Electrical Connection	5	Limiter Replacement (Dual Element Only)	15
Surface Cooking Units	6	Limiter Replacement (Triple Element Only)	15
Precautions	6	Hi-Limit Switch Replacement	15
Product Safety Devices	6	Cooling Fan Replacement	15
General Information		Cooktop Disassembly	16
Model Identification Rating Label and		Appendix A	
Ordering Replacement Parts	7	Installation Instructions	A-2
Cooking Nomenclature	7	Appendix B	
Specifications	8	Use and Care	B-2
Placement of the Cooktop	8	Cleaning Procedures	B-6
Location of Model Number	8		
Model Identification	8		
Service	8		
Parts and Accessories	8		
Extended Service Plan	8		
Grounding	8		
Cooktop Description	9		

Safety Information

As with all appliances, there are certain rules to follow for safe operation. Verify everyone who operates the cooktop is familiar with the operations and with these precautions.

Use appliance only for its intended purpose as described. Pay close attention to the safety sections of this manual.

Recognize the safety section by looking for the following symbol or the word safety.

Recognize this symbol as a safety precaution.



WARNING

If the information in this manual is not followed exactly, a fire or explosion may result causing property damage, personal injury or death.

There can be a risk of injury or electrical shock while performing services or repairs. Injury or electrical shock can be serious or even fatal. Consequently, extreme caution should be taken when performing voltage checks on individual components of a product. The electrical power supply should ALWAYS be disconnected when servicing a product.

This appliance must be properly grounded. Never plug in or direct-wire an appliance unless it is properly grounded and in accordance with all local and national codes. See "Installation Instructions" that accompany the product for the appropriate grounding procedures.

GROUND PATH SPECIFICATIONS:

Ground Path Resistance: 0.1 ohms maximum
Insulation Resistance: 250k ohms minimum

WARNING

To avoid risk of electrical shock, property damage, personal injury or death; verify wiring is correct, if components were replaced. Verify proper and complete operation of unit after servicing.

This appliance contains or produces a chemical or chemicals which are known to the state of California to cause cancer, birth defects or other reproductive harm. To reduce the risk, make sure this appliance is installed, operated, and maintained according to the instructions in this manual.

Due to the nature of cooking, fires can occur as a result of overcooking or excessive grease. Although a fire is unlikely, if one occurs proceed as follows:

Cooktop Fires

1. Do not turn on any ventilation system above the cooktop.
2. Turn all controls to the OFF position.
3. As an added precaution turn off the electricity at the main circuit breaker or fuse box.
4. Cover the food or grease to smother the fire out. If smoke or fire persist call the local fire department.

To avoid the risk of property damage or personal injury do not obstruct the flow of combustion or ventilation air.

To avoid the risk of electrical shock, serious personal injury or death: Make sure your cooktop has been properly grounded and always disconnect the electrical supply before servicing the unit.

Safety Information

Safety Practices for Servicer

Safe and satisfactory operation of electric cooktops depend upon its design and proper installation.

Servicing

Listed below are some general precautions and safety practices which should be followed in order to protect the service technician and consumer during service and after service has been completed.

1. **Check range when service is complete**—After servicing, make visual checks on electrical connection. Inform consumer of the condition of range before leaving.
2. **Adhere to all local regulations and codes when performing service.**

Before Installing

Installing the electric cooktop in compliance with local electrical building codes results in proper operation and consumer satisfaction with the cooktop.

Receiving Cooktop

Inspect cooktop thoroughly at time of delivery. Immediately report any visible damage to carrier. Damage not discovered until after accepting delivery can still be claimed by using a concealed damage report form, available from the carrier's agent.

All shipments, i.e., complete cooktop or parts, are shipped at the buyer's risk. Maytag's responsibility ends when the consignment is accepted by the carrier in "good order." Maytag supports damage claims by supplying invoices, bills of lading, and other documentation as needed. Providing this assistance, however, does not imply any responsibility for settling claims. Do not deduct claims for loss or damage from the invoice and do not withhold payment pending adjustment of claims. Do not return any units or parts for credit without written consent.

Unpacking

- Open the carton and slide cooktop out of packing.
- Remove all literature packed with the cooktop and place cooktop onto a protective flat surface.
- Avoid countertop damage by NOT sliding cooktop across the countertop.



Do not store items of interest to children in cabinets above cooktop. Children may climb on cooktop to reach these items and become seriously injured.

Electrical Requirements

220-volt, 60 Hertz, 40 amp, individual circuit which is properly grounded, polarized and protected by a circuit breaker or fuse.

Extension Cord

Due to possible pinching during installation, extension cords should not be used on products.

Electrical Connections

The wall receptacle must be placed within easy reach of the power cord.



To avoid risk of electrical shock or property damage, do not cut or remove the third (ground) prong from the power cord

K.W. Rating on Serial Plate	Circuit Protection in Amperes	Wire Size (AWG)
0 – 4.8	20	12
4.9 – 6.9	30	10
7.0 – 9.9	40	8
10.0 – 11.9	50	8
12.0 – 14.9	60	6

Safety Information

Surface Cooking Units

1. **Use Proper Pan Size**—This appliance is equipped with one or more surface units of different size. Select utensils having flat bottoms large enough to cover the surface unit heating element. The use of undersized utensils will expose a portion of the heating element to direct contact and may result in ignition of clothing. Proper relationship of utensil to burner will also improve efficiency.
2. **Never Leave Surface Units Unattended**—Boilover causes smoking and greasy spillovers that may ignite.
3. **Glazed Cooking Utensils**—Do not use glass, ceramic, earthenware, or other glazed utensils. They can damage smoothtop and can break due to sudden change in temperature.
4. **Utensil Handles Should be Turned Inward and Not Extend Over Adjacent Surface Units**—To reduce the risk of burns, ignition of flammable materials, and spillage due to unintentional contact with the utensil, the handle of a utensil should be positioned so that it is turned inward, and does not extend over adjacent surface units.

Precautions

- Do not cook food directly on range top surface, always use cookware.
- Do not mix household cleaning products. Chemical mixtures may interact with hazardous results.
- Do not put plastic items on warm cooking areas.
- Do not slide rough objects across range top surface.
- Do not leave fat heating unless you remain nearby. Fat can ignite if overheated by spilling onto hot surfaces.
- Do not allow pots to boil dry as this can cause damage to cooking surface and pan.
- Do not use range top surface as a cutting board.

Product Safety Devices

Safety devices and features have been engineered into the product to protect consumer and servicer. Safety devices must never be removed, bypassed, or altered in such a manner as to defeat the purpose for which they were intended.

General Information

This manual provides basic instructions and suggestions for handling, installing and servicing electric cooktops.

The directions, information, and warnings in this manual are developed from experience with, and careful testing of the product. If the unit is installed according to this manual, it will operate properly and will require minimal servicing. A unit in proper operating order ensures the consumer all the benefits provided by electric cooking.

This manual contains information needed by authorized service technicians to install and service electric cooktops. There may be, however, some parts which need further explanation. Refer to the Technical Sheets or toll-free technical support line to receive technical assistance from authorized service technicians.

Model Identification Rating Label and Ordering Replacement Parts

Model numbers are recorded on the rating label. Rating label is located on the bottom of the burner box. Before ordering parts, write down the correct model and serial number from rating label. This avoids incorrect shipments and delays. Please refer to parts reference material when ordering replacement parts.

Cooking Nomenclature

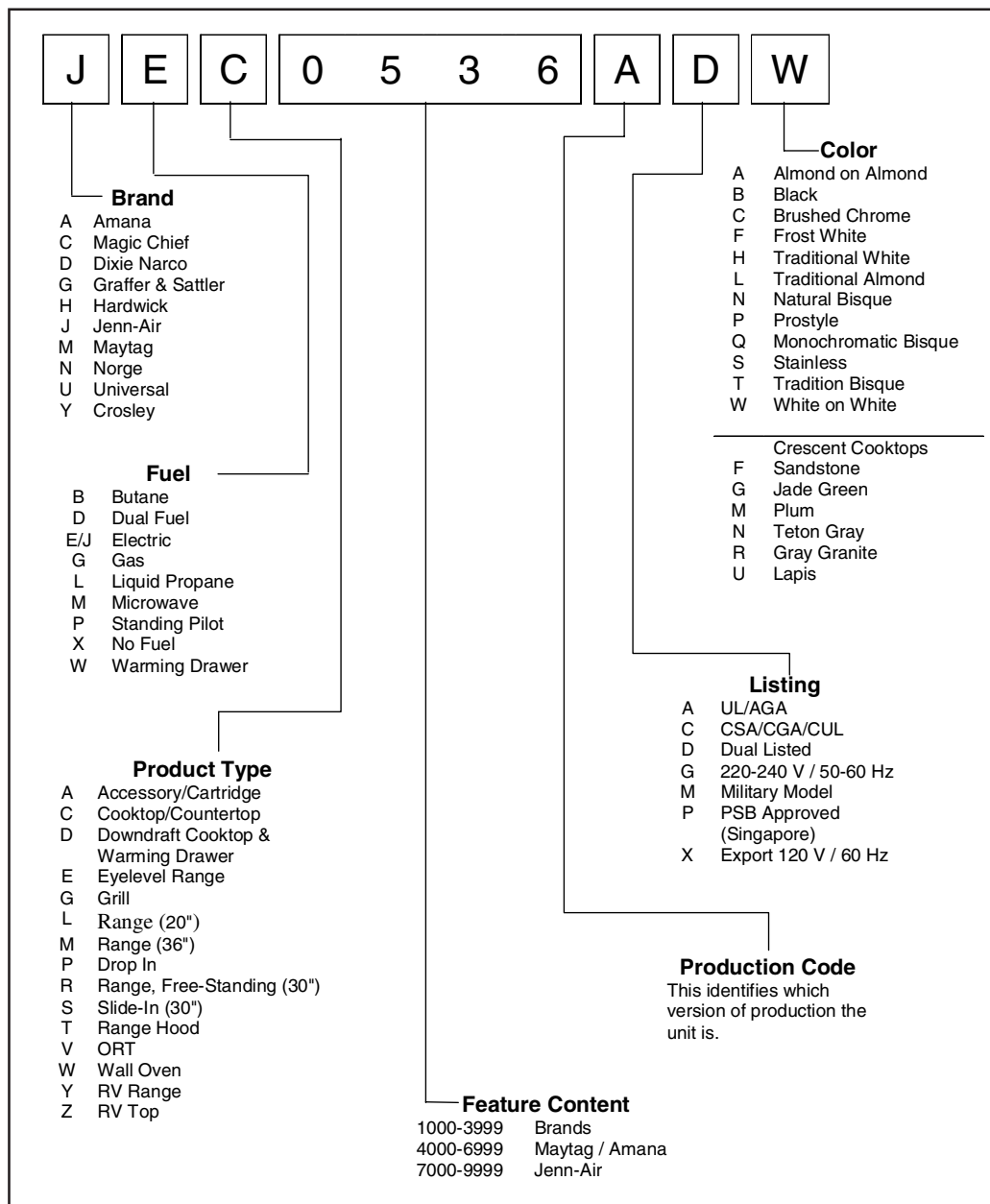

General Information

Specifications

Refer to individual Technical Sheet for specification information.

Placement of the Cooktop

This cooktop must be placed in the kitchen or comparable room. All safety guidelines must be followed (see Chapter 2) and free air flow around the cooktop is essential.

Location of Model Number

To request service information or replacement parts, the service center will require the complete model, serial, and manufacturing number of your electric cooktop. The number can be found under the unit. Lift up the unit to view the data.

Model Identification

Complete enclosed registration card and promptly return. If registration card is missing:

- For Jenn-Air product call 1-800-536-6247 or visit the Web Site at www.jennair.com
- For product in Canada call 1-800-688-2002 or visit the Web Site at www.jennair.com

When contacting provide product information located on rating plate. Record the following:

Model Number: _____
Manufacturing Number: _____
Serial or S/N Number: _____
Date of purchase: _____
Dealer's name and address: _____

Service

Keep a copy of sales receipt for future reference or in case warranty service is required. To locate an authorized servicer:

- For Jenn-Air product call 1-800-536-6247 or visit the Web Site at www.jennair.com
- For product in Canada call 1-800-688-2002 or visit the Web Site at www.jennair.com

Warranty service must be performed by an authorized servicer. We also recommend contacting an authorized servicer, if service is required after warranty expires.

Parts and Accessories

Purchase replacement parts and accessories over the phone. To order accessories for your product call:

- For Jenn-Air product call 1-800-536-6247 or visit the Web Site at www.jennair.com
- For product in Canada call 1-800-688-2002 or visit the Web Site at www.jennair.com

Extended Service Plan

We offer long-term service protection for the cooktop.

- Dependability PlusSM Extended Service Plan is specially designed to supplement Jenn-Air's strong warranty. This plan covers parts, labor, and travel charges.
Call 1-800-925-2020 for information.

Grounding Instructions

This appliance must be grounded. If an electrical short circuit occurs, grounding reduces the risk of electric shock by providing an escape wire for the electric current. Put the plug into an outlet that is properly installed and grounded.



WARNING

To avoid risk of electric shock, personal injury or death, use grounding plug properly.

Ask a qualified electrician if you do not understand the grounding instructions or if you wonder whether the appliance is properly grounded.

Keep the electrical power cord dry and do not pinch or crush it in any way.

General Information

Cooktop Description

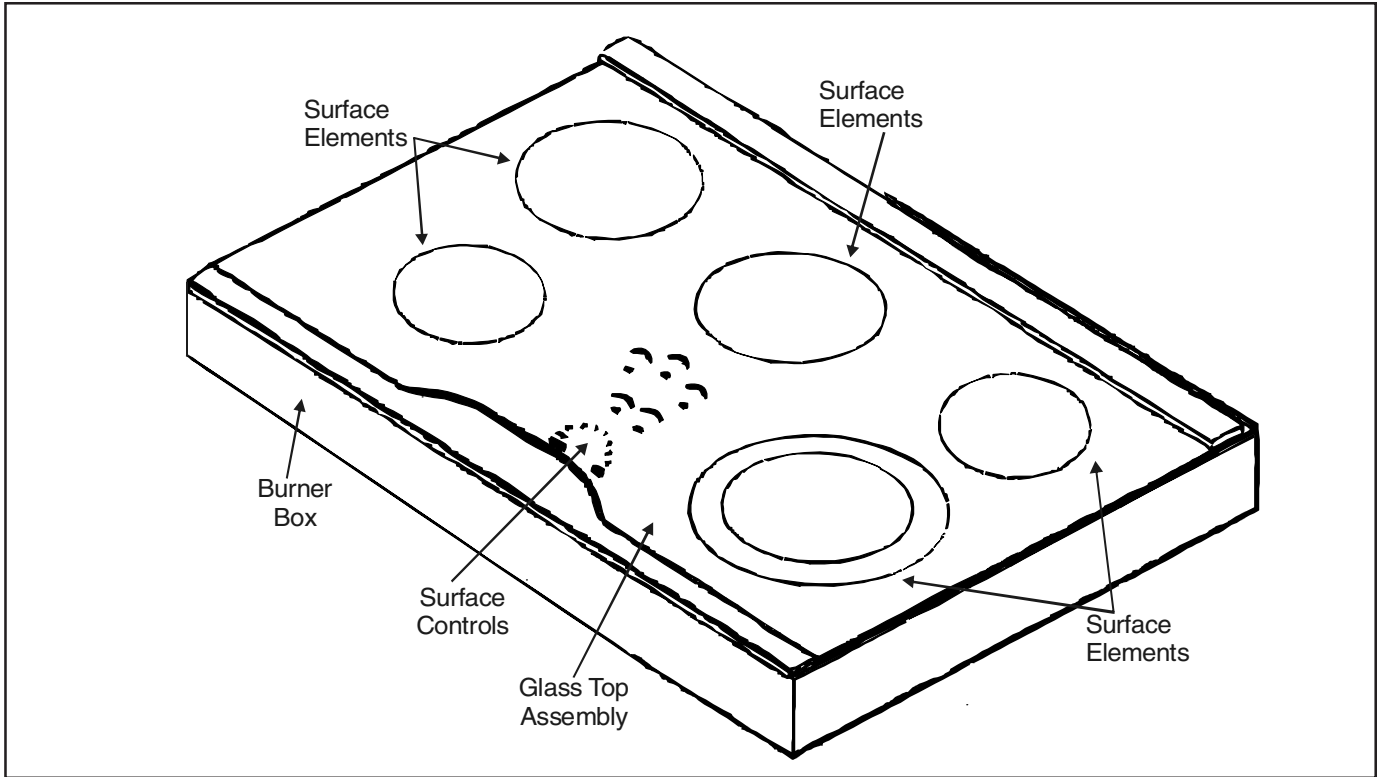

Troubleshooting Procedures



WARNING

To avoid risk of electrical shock, personal injury or death; disconnect power to cooktop before servicing, unless testing requires power.



CAUTION

- Verify proper grounding before checking for trouble.
- Be careful of the high voltage circuit.
- Do not touch any part of the circuit on the printed circuit board, since static electric discharge may damage the control panel. Always touch yourself to ground while working on this panel to discharge any static charge built up on your body.

Electronic Touch Control Troubleshooting

Symptom	Possible Cause	Correction
No element operation (power board disables power to elements)	Communication failure..... (power board disables power to elements after 10 second communication loss between control board and power board)	<ul style="list-style-type: none"> • Verify power to unit. • Verify power to power board. • Check connection between power and control board.
LOCKED LED illuminated, electronic control locked when power applied (dual, triple or bridge elements not selected), no audible alarm	Checksum failure (control board)	<ul style="list-style-type: none"> • Replace control board.
No LEDs, electronic control locked, 1 audible beep	ON LED failure (control board)	<ul style="list-style-type: none"> • Replace control board.
2 LEDs flash, (user must lock cooktop to evoke this display), no element operation, no audible alarm	Hardware watchdog error (power board).....	<ul style="list-style-type: none"> • Replace power board.
3 LEDs flash, electronic control locked, 1 audible beep	Redundant OFF key input line is not operating properly (control board)	<ul style="list-style-type: none"> • Replace control board.
6 LEDs flash, electronic control locked, no audible alarm	A/D failure (control board)	<ul style="list-style-type: none"> • Replace control board.
7 LEDs flash, electronic control locked, no audible alarm	Shorted temperature probe (power board) Shorted input (power board).....	<ul style="list-style-type: none"> • Verify sensor resistance and connections. • If symptoms persist, replace power board.
8 LEDs flash, electronic control locked, no audible alarm	Open temperature probe or open input (power board)	<ul style="list-style-type: none"> • Verify sensor resistance. • If symptoms persist, replace power board.
9 LEDs flash, electronic control locked, no audible alarm	A/D failure (power board)	<ul style="list-style-type: none"> • Replace power board.
10 LEDs flash, electronic control locked, no audible alarm	RAM test failure (power board).....	<ul style="list-style-type: none"> • Replace power board.
11 LEDs flash, electronic control locked, no audible alarm	Checksum failure (power board)	<ul style="list-style-type: none"> • Replace power board.
12 LEDs flash, electronic control locked, no audible alarm	Communication failure (control board*)	<ul style="list-style-type: none"> • Verify connections. • If symptoms persist, replace control board.
All LEDs flash, no element operation, 3 short audible beeps (continuous**)	Over temperature indication Multiple keys detected (control board), shorted key.....	<ul style="list-style-type: none"> • Verify sensor resistance. • If symptoms persist, replace control board.

*Control Board resets the Power Board every 15 seconds.

**Audible alarm (beeps) will not occur if all elements are turned off.

Troubleshooting Procedures



WARNING

To avoid risk of electrical shock, personal injury or death; disconnect power to cooktop before servicing, unless testing requires power.

Component Troubleshooting

Problem	Possible Cause	Correction
Switch burns out immediately after installation	Hot wired to neutral terminal	<ul style="list-style-type: none"> Improper wiring installation. Warranty is VOID (possible damage to glass).
Element fails to heat, but indicator light glows	Element/limit switch is defective.....	<ul style="list-style-type: none"> Check wiring against appropriate wiring diagram. Verify all terminals and connections are correct and tight. Test element, replace if defective.
Element too hot and no control of heat at any setting	Element/limit switch is defective or has welded contacts	<ul style="list-style-type: none"> Check wiring against appropriate wiring diagram. Verify all terminals and connections are correct and tight. Test element, replace if defective.
Element too hot on high setting only	Element/limit switch is defective.....	<ul style="list-style-type: none"> Check wiring against appropriate wiring diagram. Verify all terminals and connections are correct and tight. Test element, replace if defective.
Erratic operation of surface elements	Loose or broken wiring	<ul style="list-style-type: none"> Check wiring against appropriate wiring diagram. Verify all terminals and connections are correct and tight.
Indicator light remains on when control is turned OFF or does not light when control is turned ON.	Element/limit switch is defective..... Element has not cooled down	<ul style="list-style-type: none"> Check wiring against appropriate wiring diagram. Verify all terminals and connections are correct and tight. Test element, replace if defective. No correction required, allow cooktop to cool down.
Element making a "humming" noise	N/A	<ul style="list-style-type: none"> No correction required. This is caused by a 60 HZ AC current passing through element winding and does not affect performance.
Runaway surface control	Element/limit switch is defective or improper wiring	<ul style="list-style-type: none"> Check wiring against appropriate wiring diagram. Verify all terminals and connections are correct and tight. Test element, replace if defective.
Poor performance when unit is installed	Improper wiring or improper installation	<ul style="list-style-type: none"> Check wiring against appropriate wiring diagram. Verify all terminals and connections are correct and tight.
Broken glass	Faulty element/limit switch, which may have resulted in glass breakage	<ul style="list-style-type: none"> Check wiring against appropriate wiring diagram. Verify all terminals and connections are correct and tight. Test element, replace if defective.

Troubleshooting Procedures



WARNING

To avoid risk of electrical shock, personal injury or death; disconnect power to cooktop before servicing, unless testing requires power.

Problem	Possible Cause	Correction
Glass/ceramic heater is wavy or uneven	N/A.....	<ul style="list-style-type: none"> • Manufacturing process gives glass/ceramic heater panel a slight wave across the surface. This is NOT a defect.
Red spots or lines visible through glass/ceramic heater panel	N/A.....	<ul style="list-style-type: none"> • Glass/ceramic heater panels are slightly opaque. Element may transfer a glow through a panel. This is NOT a defect and has no effect on performance.
Performance on surface element is poor	Warped pots/pans	<ul style="list-style-type: none"> • Make sure pots/pans are flat on bottom.
Fan motor does not operate.	No power to fan motor Failed fan motor or winding/frozen shaft.....	<ul style="list-style-type: none"> • Check for 120 VAC supplied at fan motor. If no voltage is present, check for broken or loose wiring between fan motor and relay board. If voltage is present at fan motor, go to the next step. • Check motor winding for continuity. Check for a frozen motor shaft. Check for broken wiring between motor and neutral terminal block.

Testing Procedures



WARNING

To avoid risk of electrical shock, personal injury or death; disconnect power to cooktop before servicing, unless testing requires power.

Component Testing

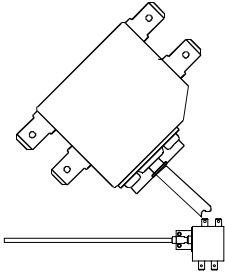
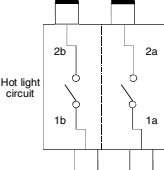
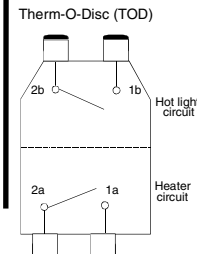
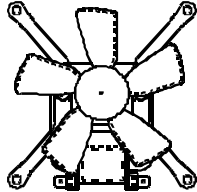
Illustration	Component	Test Procedure	Results
	Power supply	Disconnect power from cooktop and verify circuit breakers/fuses are not tripped. Check fuse rating. Check terminals at terminal block for tightness. Verify cooktop service wires are properly connected, and are in good condition. Check for proper voltage with a voltmeter	Refer to schematic diagram for correct voltage measurements
	Internal wiring	Disconnect power from cooktop, place one ohmmeter lead at the terminal block, the other lead at the line terminal of the malfunctioning part. Use the appropriate wiring diagram to repeat this procedure from the output of the control to the component, until each section is checked. A visual check of the wiring will often determine the fault location	Continuity
1200 W – 6" 1800 W – 7" 2000 W – 8" 3000 W – 9/6" (Dual element) 3000 W – 12/9/6" (Triple element)	Ribbon radiant elements	Remove one wire lead from element and measure resistance of element Dual element–1400 + 1600 = 3000 W Triple element–1050/2200/2700 W	Continuity (approximately), if not replace. 6" – 1200W: 44 to 49 Ω 7" – 1800W: 29 to 33 Ω 8" – 2000W: 26 to 30 Ω 3000W: 1400 W Inner 53 to 59 Ω 1600 W Outer 38 to 42 Ω Triple: 1050 W: 52 to 57 Ω 2200 W 24 to 28 Ω 2700 W 19 to 24 Ω
100 W	Warming element	Remove one wire lead from element and measure resistance of element	Continuity, if not replace 6" – 100W: 35 to 39 Ω Approx
	Ribbon surface thermal limiter/hot light switch	Turn surface element on and test for voltage. See wiring diagram and schematic 1a–2a 240 VAC 1b–2b 120 VAC Disconnect leads and measure resistance on the following: 1a–2a room temperature–continuity 1b–2b room temperature–infinite	240 VAC Electrovac  Therm-O-Disc (TOD) 
	Cooling fan	Remove wire leads from terminals and measure resistance of the motor..... Verify voltage to cooling fan terminals....	Should indicate resistance. If infinite ohms, replace cooling fan 120 VAC See Wiring Diagram/Schematic for terminal identification RPM: 2100 ± 400

Testing Procedures



WARNING

To avoid risk of electrical shock, personal injury or death; disconnect power to oven before servicing, unless testing requires power.

Illustration	Component	Test Procedure	Results
	Control surface	Measure voltage at the following terminals L1 to L2.....	Refer to wiring diagram/schematic
	Thermostat	Closed..... Open	Refer to wiring diagram/schematic 165°F 215°F

Disassembly Procedures



WARNING

To avoid risk of electrical shock, personal injury or death, disconnect power to cooktop before servicing, unless testing requires power.

Main Top Removal

1. Disconnect power to cooktop.
2. Remove cooktop from installation position and place face down on protected surface.
3. Remove screws securing main top to burner box bottom.
4. Remove screws securing control panel box and conduit mounting plate to burner box assembly.
5. Remove main top.
6. Reverse procedure to reassemble, verifying that cooktop frame is properly aligned.

NOTE: Make sure the pieces of insulation, located in the front left and right rear corners, are put back in place. Failure to do so could create excessive cabinet temperatures.

Element Replacement

1. Remove main top, see "Main Top Removal" procedure.
2. Remove screws securing element clips to main top.

NOTE: Element clips are positioned at numbered locations. If element clips are removed from element, note the locations prior to removal.

3. Disconnect and label wiring to element.
4. Replace element and reverse procedure to reinstall.

Sensor Replacement

1. Remove main top, see "Main Top Removal" procedure.
2. Remove screws securing element clips to main top.
3. Lower element and remove screws securing sensor to element.
4. Disconnect wiring to sensor.
5. Replace sensor and reverse procedure to reinstall.

Limiter Replacement (Dual Element Only)

1. Remove main top, see "Main Top Removal" procedure.
2. Remove screws securing element clips to main top.
3. Lower element and remove screws securing limiter to element.
4. Disconnect and label wiring to limiter.
5. Replace limiter and reverse procedure to reinstall.

Limiter Replacement (Triple Element Only)

1. Remove main top, see "Main Top Removal" procedure.
2. Remove screws securing element clips to main top.
3. Lower element and remove screws securing limiter to element.
4. Disconnect and label wiring to limiter.
5. Replace limiter and reverse procedure to reinstall.

Hi-Limit Switch Replacement

1. Remove main top, see "Main Top Removal" procedure.
2. Remove screws securing hi-limit switch to the mounting plate and remove hi-limit switch.
3. Disconnect and label wiring to hi-limit switch.
4. Replace hi-limit switch and reverse procedure to reinstall.

Cooling Fan Replacement

1. Disconnect electricity to unit.
2. Remove knobs from valve stems.

NOTE: To remove knob(s), slide a rag under the knob and pull upward.

3. Remove cooktop from installation position and place face down on protected surface.
4. Remove screws securing bottom baffle to burner box bottom.
5. Remove baffle to gain access to fan.
6. Remove screws securing cooling fan to burner box bottom.
7. Disconnect and label wiring to cooling fan.
8. Replace cooling fan and reverse procedure to reinstall.

Disassembly Procedures

WARNING

To avoid risk of electrical shock, personal injury or death, disconnect power to cooktop before servicing, unless testing requires power.

Cooktop Disassembly

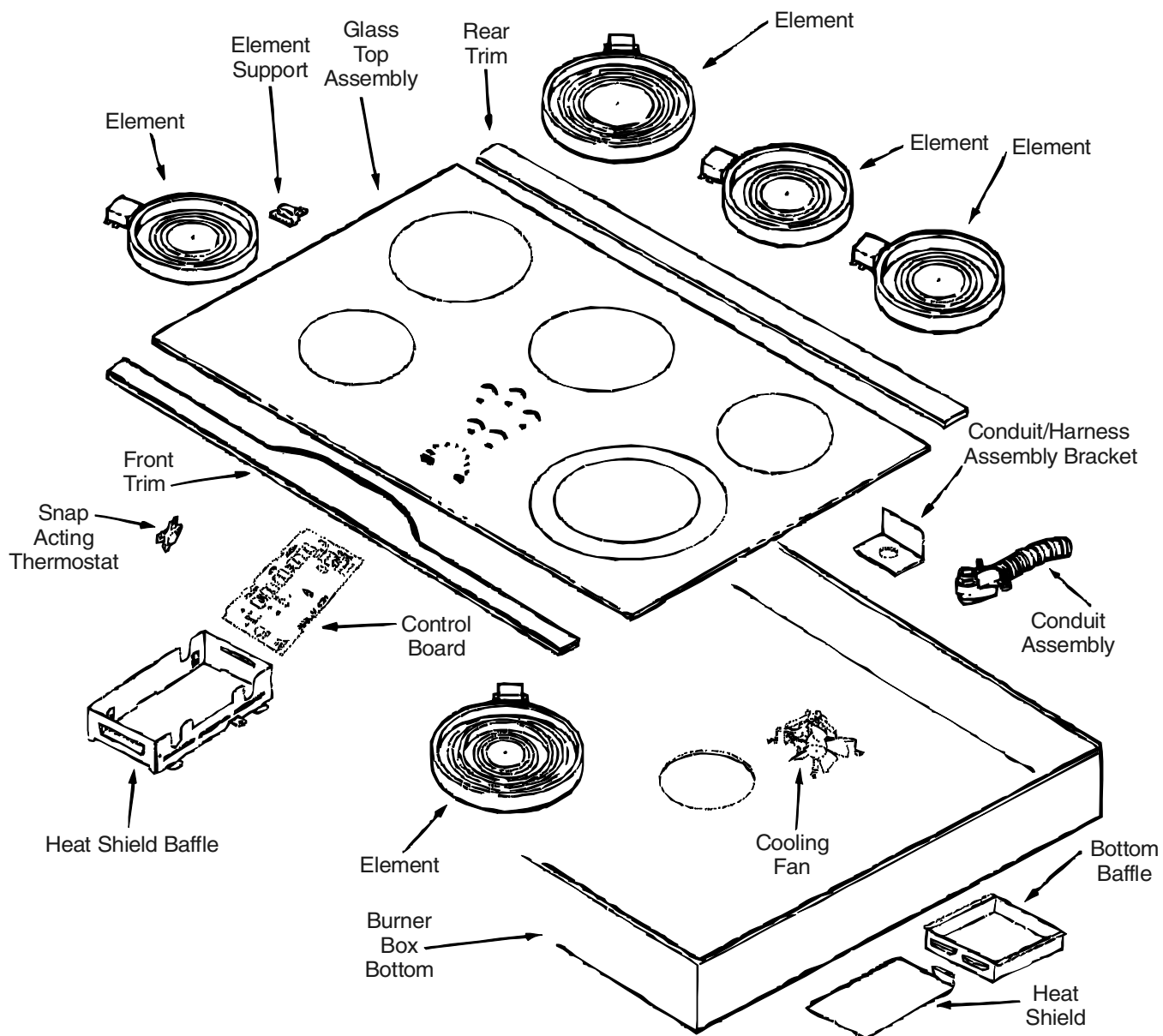

Appendix A

Installation Instructions

Installing Cabinetry Over Your Cooktop

A = 30" (76.2 cm) minimum clearance between the top of the cooktop and the bottom of an unprotected wood or metal cabinet.

A = 24" (60.96 cm) minimum when bottom of wood or metal cabinet is protected by not less than 1/4" (0.635 cm). FLAME RETARDANT millboard covered with not less than no. 28 MSG sheet steel, 0.015" (0.038 cm) stainless steel, 0.024" (0.061 cm) aluminum or copper.

* To eliminate the risk of burns or fire by reaching over heated surface units, cabinet storage space located above the surface units should be avoided. If cabinet storage is to be provided, the risk can be reduced by installing a range hood that projects horizontally a minimum of 5 inches beyond the bottom of the cabinets.

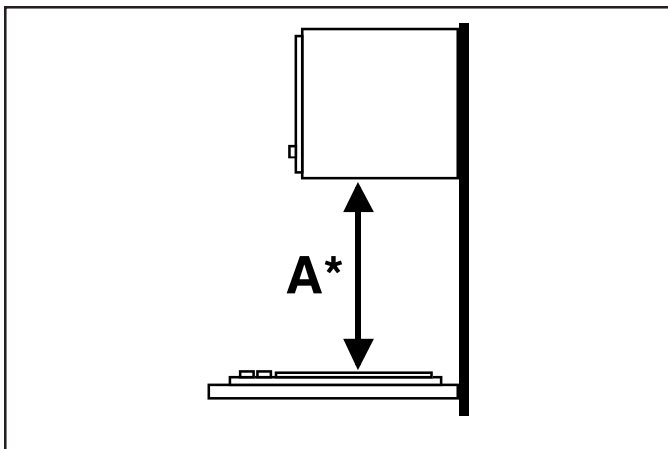

Important Installation Suggestions

1. Chamfer all exposed edges of decorative laminate to prevent damage from chipping.
2. Radius corners of cutout and file to insure smooth edges and prevent corner cracking.
3. Rough edges, inside corners which have not been rounded and forced fits can contribute to cracking of the countertop laminate.
4. Countertop must be supported within 3" (7.62 cm) of cutout.



CAUTION

Warranty is void on equipment installed other than as recommended by manufacturer.

Electrical Wiring Information

The neutral of this unit is grounded to the frame through the solid copper grounding wire. If used on new branch-circuit installations (1996 NEC), mobile homes, recreational vehicles, or in an area where local codes prohibit grounding through the neutral conductor, untwist or disconnect the solid copper wire and connect the ground wire to ground in accordance with local code. Connect the white neutral to the service neutral. Connect all wires to the branch circuit with approved connectors. Use copper or aluminum wire. If aluminum wire is used, use connectors recognized for joining aluminum to copper.



CAUTION

This is a two-wire with copper ground 208/240 volt AC appliance. Copper ground is chassis ground and must be connected to supply ground.

Proper Electrical Supply

You must provide an adequate electrical supply system as required for your cooktop. All wire connections must be in accordance with local codes and properly insulated. Check with local utility for governing electrical codes and ordinances. In the absence of local electrical codes, the National Electrical Code, NFPA No. 70, governing electric range installations must be followed.

A copy of the National Electrical Code, NFPA No. 70, can be obtained by writing to:

National Fire Protection Association

Batterymarch Park

Quincy, Massachusetts 02269

A two-wire, 240 volt unit. Connect only to a 3-wire, 120/240-volt power supply; the neutral conductor is not required for the operation of the appliance. The potential at the power supply electrical connections shall be 150-volts-to-ground or less. The grounding (bare) wire is connected to the frame of the unit; connect it to a separate ground. The chart below recommends the minimum circuit protector and wire size if the appliance is the only unit on the circuit. If smaller sizes of wire are used, the unit efficiency will be reduced and a fire hazard may be created. It is advisable that the electrical wiring and hookup be accomplished by a competent electrician.

K.W. Rating on Serial Plate	Circuit Protection in Amperes	Wire Size (AWG)
0 – 4.8	20	12
4.9 – 6.9	30	10
7.0 – 9.9	40	8
10.0 – 11.9	50	8
12.0 – 14.9	60	6

Installation Instructions

Junction Box Connection

Junction box is not supplied with cooktop. Junction box must be U.L. or C.S.A. listed and meet NEC and Mobile Home Manufacturers Association Standards.

- Three-wire conductor junction box allowed for residential usage in United States.
- Four-wire conductor junction box required in Canada and for most mobile home installations, but can be used for residential.
- Refer to local, municipal, and state building codes.

NOTE: A power cord must not be used.

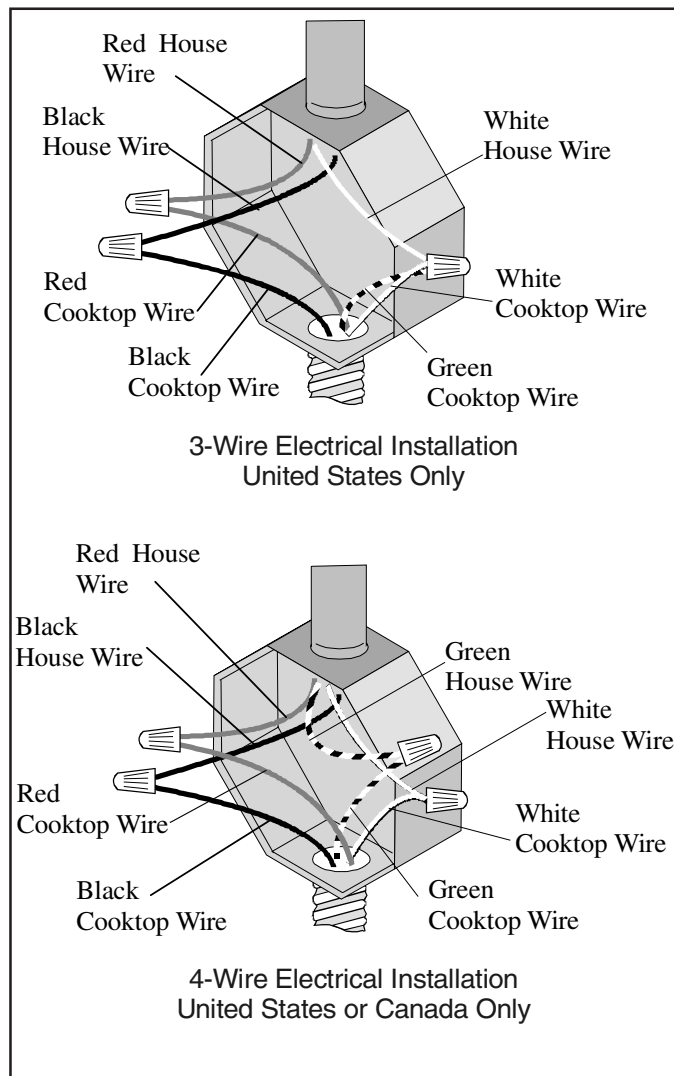

Notice To Installer

Follow accompanying instruction carefully.

CAUTION

Never use a metal blade to pry knob off. If knob cannot be easily removed, tuck folds of a dish-towel under knob skirt and pull upward with steady, even pressure.

Preparation Of Countertop

The cutout in the countertop into which the appliance is to be installed should be prepared according to the cutout dimensions given on page 1 of these instructions.

CAUTION

Cutout dimensions are critical. Dimensions must be measured and cut accurately to within + 1/16" (.16 cm) to insure proper fit.

Installation Of Appliance

1. Remove the cooktop from the carton and place it upside down over two soft pads making sure control knobs do not interfere with any surface.
2. Provide cutout in countertop.
3. Place unit in the cutout.
4. Make electrical wire connection to unit. Consult local codes for proper power hook-up.
5. Test to insure control knobs operate all elements properly.

Installation Instructions

INSTALLATION INSTRUCTIONS

Radiant Cooktop Models JEC0530 & JEC0536

JENN-AIR

403 WEST FOURTH STREET, NORTH D NEWTON, IA 50208

IMPORTANT - SAVE FOR THE LOCAL ELECTRICAL INSPECTOR'S USE

IMPORTANT: Installation should be performed only by an authorized Jenn-Air Service Contractor or other qualified installer. Read safety precautions in the Use & Care Manual before using this appliance.

(Dimensions shown in both inches and centimeters)

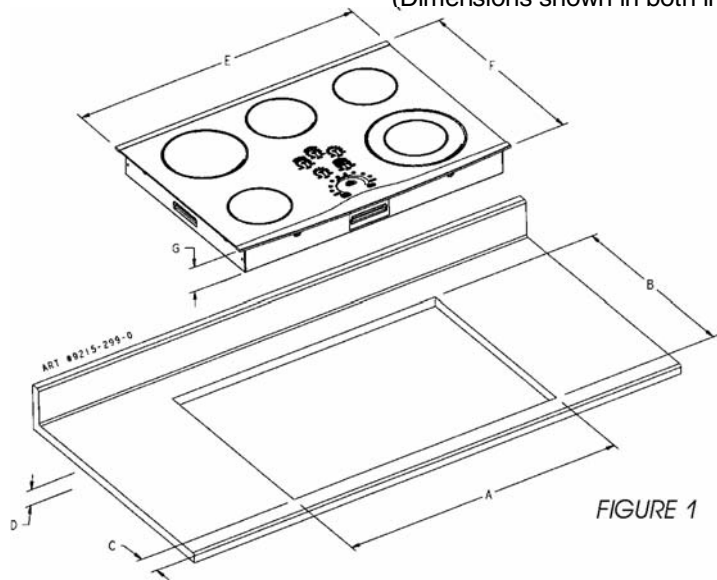

FIGURE 1

NOTE: "D" is clearance needed for unit depth measure down from top of countertop. Typical for all units.

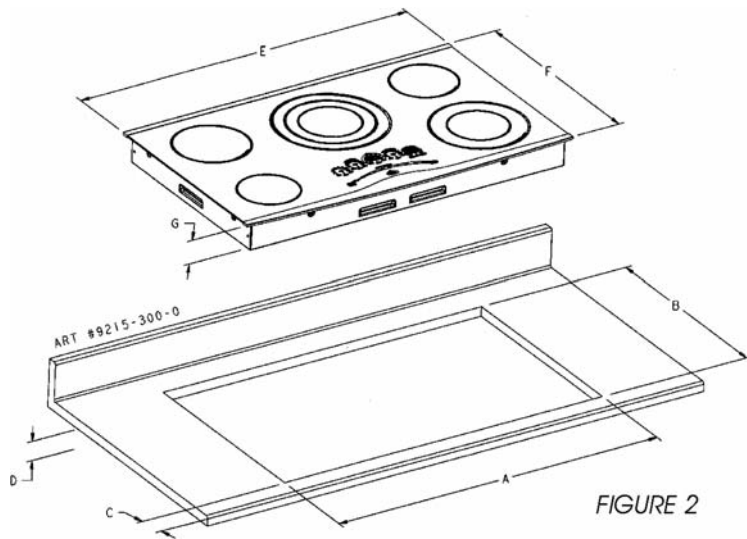

FIGURE 2

JEC0530 FOUR-ELEMENT RADIANT COOKTOPS

DIMENSIONS		
	inches	cm
A	29-1/16 ± 1/16	74.0 ± 0.2
B	20-3/8 ± 1/16	51.9 ± 0.2
C	2-1/8	5.4
D	4-1/4 min. clear	10.8
E	29-15/16	76.0
F	21-1/2	54.6
G	3-5/8	7.6

JEC0536 FIVE-ELEMENT RADIANT COOKTOPS

DIMENSIONS		
	inches	cm
A	34-9/16 ± 1/16	87.9 ± 0.2
B	20-3/8 ± 1/16	51.9 ± 0.2
C	2-1/8	5.4
D	4-1/4 min. clear	10.8
E	35-5/16	89.7
F	21-1/2	54.6
G	3-5/8	7.6

IMPORTANT

CUTOUT
DIMENSIONS ARE
CRITICAL

UNITS PROVIDED WITH 1/2 (1.3 cm) I.D. FLEXIBLE CABLE 48 (121.9 cm) LONG WITH 6 (15.2 cm) WIRE LEADS AT END, FURNISHED AND INSTALLED BY MANUFACTURER (CONNECT TO 240 VOLT ELECTRICAL SERVICE).

INSTRUCTIONS TO INSTALLER:

S Side and Back Wall Clearance: Unit may be safely installed as near as 2 1/2 inches (6.35 centimeters) from side walls and 3/4 inch (1.91 centimeters) from back wall.

Notice To Installer: Leave these instructions with the appliance.

Notice To Consumer: Retain these instructions for future reference.

8101P645-60
(03-04-00)

Appendix B

USING YOUR COOKTOP

Control Locations

Model JEC0536

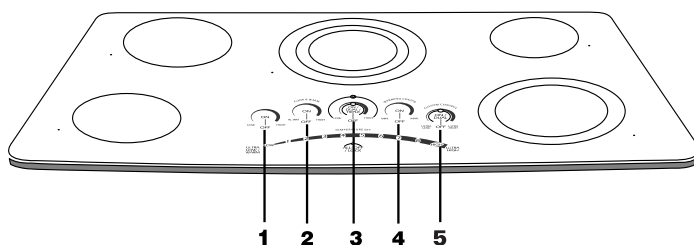

1. Left front element
2. Left rear element (cook and warm)
3. Center element (triple element)
4. Right rear element (warming element)
5. Right front element (custom control element)

Model JEC0530

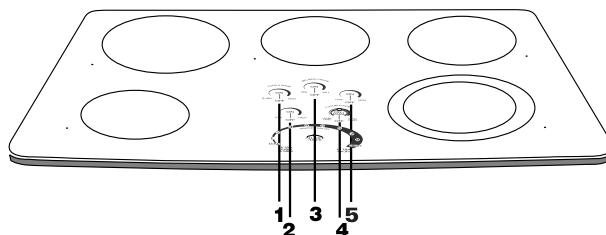

1. Left rear element (cook and warm)
2. Left front element
3. Center element (warming element)
4. Right front element (custom control element)
5. Right rear element

USING YOUR COOKTOP

Surface Controls

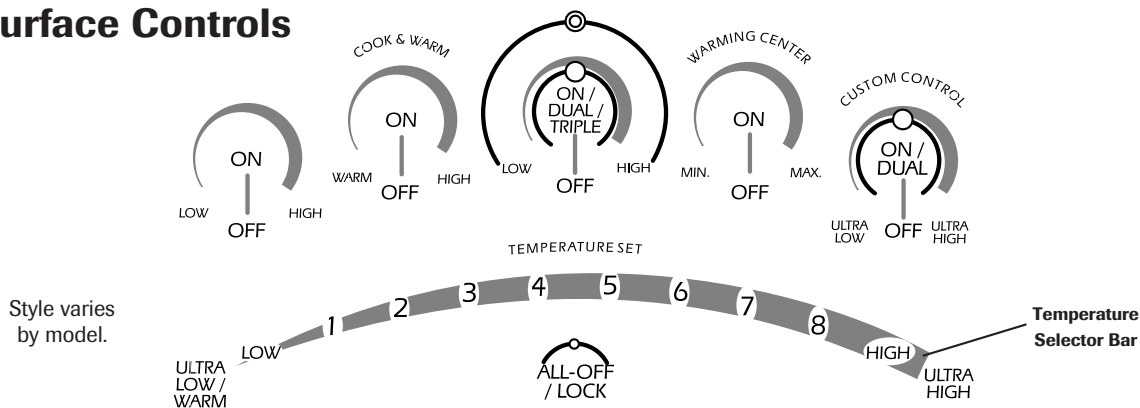

Using the Touch Control

- Press the desired **ON** pad. A light on the left side of the control will blink.
- While the light is blinking, press the desired temperature setting using the Temperature Selector Bar.
- A beep will sound each time a pad is pressed.

Notes

- If a temperature setting is not selected within approximately 10 seconds, the element will automatically shut off.
- To change the temperature setting while cooking with one element, press the **ON** pad and select a new temperature on the Temperature Selector Bar while the light is blinking.
- To change the temperature setting when multiple elements are on, press the **ON** pad for the desired element, then select a new temperature on the Temperature Selector Bar while the light is blinking.

Setting the Controls

1. Place pan on surface element.
2. Press **ON**.
3. Select the temperature setting using the Temperature Selector Bar.
4. When cooking is completed, press **OFF** and remove the pan.

Suggested Heat Settings

The size, type of cookware and cooking operation will affect the heat setting. For information on cookware and other factors affecting heat settings, refer to "Cooking Made Simple" booklet.

SETTINGS	USES
Ultra High	Offers higher speed cooking that can be used to quickly bring water to a boil, searing, blackening and for large-quantity cooking.
High	Use to bring liquid to a boil. Always reduce setting to a lower heat when liquids begin to boil or foods begin to cook.
6-8 (medium high)	Use to brown meat, heat oil for deep fat frying or sauteing. Maintain fast boil for large amounts of liquids.
4-6 (medium)	Use to maintain slow boil for large amounts of liquids and for most frying operations.
2-4 (medium low)	Use to continue cooking covered foods or steam foods.
Low	Use to melt butter or chocolate.
Ultra Low/ Warm	Offers a lower temperature for cooking delicate sauces without scorching. Use to keep cooked foods warm.

USING YOUR COOKTOP

On Indicators

All Models - The **LOW** light will illuminate when the element is on.

Hot Surface Indicator Lights

A Hot Surface light is located next to each element. The light will illuminate when the cooking area is hot. It will remain on, even after the control is turned off, until the area has cooled.

Cooling Fan

A cooling fan will automatically turn on when any element is turned on. The fan is used to keep internal parts inside the cooktop cool. The fan will automatically turn off when all the elements are off. With heavy use, the fan may continue to run after the controls are turned off until the cooktop has cooled.

Control Lockout

The touchpad controls can be locked out for cleaning and to prevent unwanted use.

To lock controls:

Press and hold the **All-Off/Lock** pad for three seconds.

To unlock controls:

Press and hold the **All-Off/Lock** pad for three seconds. The **All-Off/Lock** light will illuminate whenever the controls are locked.

Cook and Warm Element

The Cook and Warm Element, located in the left rear position, is a fully-functioning element that provides an **Ultra Low/Warm** heat setting for holding delicate sauces and keeping cooked foods warm.

To use the **Warm** setting, touch **ON**, and then touch **Ultra Lo/Warm** on the Temperature Selector Bar.

To use the regular temperature settings, touch **ON**, and then touch any setting from **LOW** to **HIGH** on the Temperature Selector Bar.

Note: When using the normal temperature settings to prepare foods, it will take a few minutes for the cooking area to cool to the **Ultra Lo/Warm** temperature setting.

Triple Element (select models)

The Triple Element, located in the center position, offers three different element sizes to accommodate different pan sizes. Use one, two or three sections of the element to best match your pan.

To use the element:

1. Press **ON**. The inner-most element will activate.
2. Set the desired temperature on the Temperature Selector Bar.
3. Press **ON** again to activate the center and middle areas.
4. Press **ON** again to activate all three areas.

Note: The Triple Element will remember the setting from the last time it was used. Therefore, one, two or all three areas may activate when **ON** is pressed. To change the areas activated, press **ON** again while the indicator light on the left is flashing. If the indicator light on the left is not flashing, press **ON** twice. Red lights on the control will indicate which areas of the element are activated.

Custom Control Dual Element

The Custom Control Dual Element offers two element sizes and is located in the right front position. This element uses an electronic sensor to constantly monitor and adjust heat output for precise and consistent temperature control.

To use the element:

1. Press **ON**. The inner-most element will activate.
2. Set the desired temperature on the Temperature Selector Bar.
3. Press **ON** again to activate the entire element.

Note: The Custom Control dual Element will remember the setting from the last time it was used. Therefore, one or both areas may activate when **ON** is pressed. To change the areas activated, press **ON** again while the indicator light on the left is flashing. If the indicator light on the left is not flashing, press **ON** twice. A red light on the control will indicate which areas of the element are activated.

USING YOUR COOKTOP

Warming Center

Use the Warming Center to keep cooked foods warm, such as vegetables, gravies and oven-safe dinner plates.

Setting the Control:

1. Press **ON**.
 - Warming temperatures are approximate and are indicated on the control as **Ultra Low/Warm, Low, 1-8, High** and **Ultra High**.
2. When done, press **OFF** and remove food.
 - The Hot Surface Indicator light will go off when the Warming Center surface has cooled.

SETTINGS	TYPE OF FOOD
ULTRA LOW - 2	Pastries/Breads Breakfast Foods (Eggs) Delicate Foods
3 - 5	Soups (Cream) Stews Vegetables Meats
6 - 8	Sauces Gravies
HIGH - ULTRA HIGH	Hot Beverages Soups (Liquid)

Notes

- All foods should be covered with a lid or aluminum foil to maintain food quality.
- When warming pastries and breads, the cover should have an opening to allow moisture to escape.
- Do not use plastic wrap to cover foods. Plastic may melt on to the surface and be very difficult to clean.
- Use only cookware and dishes recommended as safe for cooktop use.
- Always use potholders when removing food from the Warming Center as cookware and plates will be hot.
- **Never** warm food for longer than one hour (eggs for 30 minutes), as food quality may deteriorate.
- Do not heat cold food on the Warming Center.
- The quantity and type of food being held may affect the required heat setting.
- Do not use large utensils or large amounts of food as this may cause uneven heating.
- Always hold food at proper food temperatures. USDA recommends food temperatures between 140° - 170° F (except pastries).

Cleaning Procedures

CARE & CLEANING

Cleaning Procedures

CAUTION

- Be sure appliance is off and all parts are cool before handling or cleaning. This is to avoid damage and possible burns.
- To prevent staining or discoloration, clean appliance after each use.

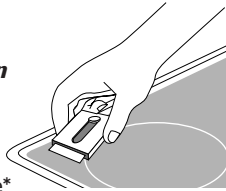
PART	PROCEDURE
Smoothtop - Glass-Ceramic	<p><i>Never use oven cleaners, chlorine bleach, ammonia or glass cleaners with ammonia. NOTE: Call an authorized servicer if the glass-ceramic top should crack, break or if metal or aluminum foil should melt on the cooktop.</i></p> <ul style="list-style-type: none"> • Allow the cooktop to cool before cleaning. • General - Clean cooktop after each use, with a damp paper towel and Cooktop Cleaning Creme* (Part No. 20000001)**. Then, buff with a clean dry cloth. <p>NOTE: Permanent stains will develop if soil is allowed to cook on by repeatedly using the cooktop when soiled.</p> <ul style="list-style-type: none"> • Heavy Soils or Metal Marks - Dampen a “scratchless” or “never scratch” scrubber sponge. Apply Cooktop Cleaning Creme* (Part No. 20000001)** and scrub to remove as much soil as possible. Apply a thin layer of the creme over the soil, cover with a damp paper towel and let stand 30-45 minutes (2-3 hours for very heavy soil). Keep moist by covering the paper towel with plastic wrap. Scrub again, then buff with a clean dry cloth. <p>NOTE: Only use a CLEAN, DAMP “scratchless” pad that is safe for non-stick cookware. The pattern and glass will be damaged if the pad is not damp, if the pad is soiled, or if another type of pad is used.</p> <ul style="list-style-type: none"> • Burned-on or Crusty Soils - Scrub with a “scratchless” or “never scratch” scouring pad and Cooktop Cleaning Creme*. Hold a razor blade scraper at 30° angle and scrape any remaining soil. Then, clean as described above. <p>NOTE: Do not use the razor blade for daily cleaning as it may wear the pattern on the glass.</p> <ul style="list-style-type: none"> • Melted Sugar or Plastic - Immediately turn element to LOW and scrape sugar or plastic from hot surface to a cool area. Then turn element OFF and allow to cool. Clean residue with razor blade scraper and Cooktop Cleaning Creme*. 
Cooktop Trim Stainless Steel (select models)	<ul style="list-style-type: none"> • DO NOT USE ANY CLEANING PRODUCT CONTAINING CHLORINE BLEACH. • ALWAYS WIPE WITH THE GRAIN WHEN CLEANING. • DO NOT USE ORANGE OR ABRASIVE CLEANERS. • Daily Cleaning/Light Soil -- Wipe with one of the following - soapy water, white vinegar/water solution, Formula 409 Glass and Surface Cleaner* or a similar glass cleaner - using a sponge or soft cloth. Rinse and dry. To polish and help prevent fingerprints, follow with Stainless Steel Magic Spray* (Jenn-Air Model A912, Part No. 20000008)**. • Moderate/Heavy Soil -- Wipe with one of the following - Bon Ami*, Smart Cleanser*, or Soft Scrub* - using a damp sponge or soft cloth. Rinse and dry. Stubborn soils may be removed with a damp multi-purpose Scotch-Brite* pad; rub evenly with the grain. Rinse and dry. To restore luster and remove streaks, follow with Stainless Steel Magic Spray*. • Discoloration -- Using a damp sponge or soft cloth, wipe with Cameo Stainless Steel Cleaner*. Rinse immediately and dry. To remove streaks and restore luster, follow with Stainless Steel Magic Spray*.

* Brand names are registered trademarks of the respective manufacturers.

** To order call 1-800-JENNAIR (1-800-536-6247).