

Service

This manual is to be used by qualified appliance technicians only. Maytag does not assume any responsibility for property damage or personal injury for improper service procedures done by an unqualified person.

Dual Fuel Slide-In Range

This Base Manual covers general information
Refer to individual Technical Sheet
for information on specific models

This manual includes, but is
not limited to the following:

JDS8850AAB/Q/S/W
JDS8850ACS/W
JDS9860AAB/P/W
JDS9860ACB/P/W

Important Information

Pride and workmanship go into every product to provide our customers with quality products. It is possible, however, that during its lifetime a product may require service. Products should be serviced only by a qualified service technician who is familiar with the safety procedures required in the repair and who is equipped with the proper tools, parts, testing instruments and the appropriate service information. **IT IS THE TECHNICIANS RESPONSIBILITY TO REVIEW ALL APPROPRIATE SERVICE INFORMATION BEFORE BEGINNING REPAIRS.**

Important Notices for Servicers and Consumers



WARNING

To avoid risk of severe personal injury or death, disconnect power and/or gas before working/servicing on appliance to avoid electrical shock.

To locate an authorized servicer, please consult your telephone book or the dealer from whom you purchased this product. For further assistance, please contact:

Customer Service Support Center

CAIR Center

Web Site

Telephone Number

WWW.JENNAIR.COM 1-800-536-6247

CAIR Center in Canada 1-800-688-2002

Recognize Safety Symbols, Words, and Labels



DANGER

DANGER—Immediate hazards which **WILL** result in severe personal injury or death.



WARNING

WARNING—Hazards or unsafe practices which **COULD** result in severe personal injury or death.



CAUTION

CAUTION—Hazards or unsafe practices which **COULD** result in minor personal injury, product or property damage.

Table of Contents

Important Information	2	Disassembly Procedures	
Important Safety Information		Removing and Replacing Range	24
All Appliances	4	Cartridge Assembly (Select Models)	24
Surface Cooking Units	5	Top Burner	24
Safety Practices for Servicer	5	Top Burner Lower Assembly	24
Servicing	5	Manifold and Top Burner	24
Receiving Oven	5	Regulator	24
Connecting Range to Gas	6	Infinite Switch	24
Extension Cords	6	Spark Module	24
Using the Oven	5	Maintop Assembly	25
Ovens	6	Control Panel	25
Self-Cleaning Ovens	6	Electronic Control	25
Glass/Ceramic Cooking Surfaces	6	Bottom Access Panel	25
Ventilation Hoods	7	Indicator Lights	25
Oven Fires	7	Meat Probe Receptacle (Select Models)	26
Precautions	7	Back Panel	26
Product Safety Devices	7	Cooling Fan	26
General Information		Transformer	26
Cooking Nomenclature	8	Bake Element	26
Specifications	9	Broil Element	26
Placement of the Oven	9	Downdraft Blower Motor (Select Models)	26
Do Not Block Air Vents	9	Oven Sensor	26
Location of Model Number	9	Front Side Trim	26
Model Identification	9	Oven Light Bulb/Oven Light Socket	26
Service	9	Oven Light Switch	27
Parts and Accessories	9	Convection Fan	27
Extended Service Plan	9	Oven Vent/Smoke Eliminator	27
Range Description	10	Hi-Limit Thermostat	27
Troubleshooting Procedures		Oven Door Latch	27
Troubleshooting Chart	11	Oven Door Removal	28
Fault Code Chart	13	Oven Door Hinge	28
Oven Sensor and Meat Probe Charts	15	Door Disassembly	28
Testing Procedures		Appendix A: Installation Instructions	
Component Testing Procedures	16	Model JDS8850A**	A-2
Oven Control Testing Procedures	19	Model JDS9860A**	A-9
Relay Logic	21	Appendix B: Use Information	
Quick Test Mode	22	Model JDS8850A**	B-2
Description of Fault Codes	23	Model JDS9860A**	B-7
		Care Information	B-12
		Appendix C	
		LP Conversion Instructions	C-2

Important Safety Information

WARNING

To reduce the risk of the appliance tipping, it must be secured by a properly installed anti-tip bracket(s). To make sure bracket has been installed properly, remove the storage drawer and look under the range with a flashlight. Bracket(s) must be engaged in the rear corner of the range.



- ALL RANGES CAN TIP
- INJURY TO PERSONS COULD RESULT



- INSTALL ANTI-TIP BRACKET(S) PACKED WITH RANGE
- SEE INSTALLATION INSTRUCTIONS

WARNING

To avoid personal injury, do not sit, stand or lean on oven door or oven drawer.

WARNING

To avoid risk of electrical shock, personal injury, or death, make sure your range has been properly grounded and always disconnect it from main power supply before any servicing.

WARNING

This appliance contains or produces a chemical or chemicals which can cause death or serious illness and which are known to the state of California to cause cancer, birth defects or other reproductive harm. To reduce the risk from substances in the fuel or from fuel combustion make sure this appliance is installed, operated, and maintained according to the instructions in this booklet.

WARNING

To avoid risk of electrical shock, property damage, personal injury, or death, verify wiring is correct, if components were replaced. Verify proper and complete operation of unit after servicing.

As with all appliances, there are certain rules to follow for safe operation. Verify everyone who operates oven is familiar with the operations and with these precautions.

Use appliance only for its intended purpose as described. Pay close attention to the safety sections of this manual. Recognize the safety section by looking for the symbol or the word safety.

Recognize this symbol as a safety precaution.



WARNING

If the information in this manual is not followed exactly, a fire or explosion may result causing property damage, personal injury or death.

Do not store or use gasoline or other flammable vapors and liquids in the vicinity of this or any other appliance.

WHAT TO DO IF YOU SMELL GAS

- Extinguish any open flame.
- Do not try to light any appliance.
- Do not touch any electrical switch; do not use any phone in your building.
- Immediately call your gas supplier from a neighbor's phone. Follow the gas supplier's instructions.
- If you cannot reach your gas supplier, call fire department.

Installation and service must be performed by an authorized installer, service agency or gas supplier.

ALL APPLIANCES

1. Proper Installation—Be sure your appliance is properly installed and grounded by a qualified technician.
2. Never Use Your Appliance for Warming or Heating the Room.
3. Do Not Leave Children Alone—Children should not be alone or unattended in the area where the appliance is in use. They should never be allowed to sit or stand on any part of the appliance.
4. Wear Appropriate Apparel—Loose fitting or hanging garments should never be worn while using appliance.

Important Safety Information

5. User Servicing—Do not repair or replace any part of the appliance unless specifically recommended in the manual. All other servicing should be referred to a qualified technician.
6. Storage in or on Appliance—Flammable materials should not be stored in an oven or near surface units.
7. Do Not Use Water on Grease Fires—Smother fire or flame, or use dry chemical or foam-type extinguisher.
8. Use Only Dry Potholders—Moist or damp potholders on hot surfaces may result in burns from steam. Do not let potholder touch elements. Do not use a towel or other bulky cloth.

SURFACE COOKING UNITS

1. Use Proper Pan Size—This appliance is equipped with one or more surface units of different size. Select utensils having flat bottoms large enough to cover the surface unit heating element. The use of undersized utensils will expose a portion of the heating element to direct contact and may result in ignition of clothing. Proper relationship of utensil to burner will also improve efficiency.
2. Never Leave Surface Units Unattended at High Heat Settings—Boilover causes smoking and greasy spillovers that may ignite.
3. Protective Liners—Do not use aluminum foil to line oven bottom. Improper installation of these liners may result in a risk of electrical shock or fire.
4. Glazed Cooking Utensils—Do not use glass, ceramic, earthenware, or other glazed utensils. They can damage smoothtop and can break due to sudden change in temperature.
5. Utensil Handles Should be Turned Inward and Not Extend Over Adjacent Surface Units—To reduce the risk of burns, ignition of flammable materials, and spillage due to unintentional contact with the utensil, the handle of a utensil should be positioned so that it is turned inward, and does not extend over adjacent surface units.

NOTE: The maximum gas supply pressure for these models must not exceed 14 inches W.C.P.

Safety Practices for Servicer

Safe and satisfactory operation of gas ranges depends upon its design and proper installation. However, there is one more area of safety to be considered:

Servicing

Listed below are some general precautions and safety practices which should be followed in order to protect the service technician and consumer during service and after service has been completed.

1. Gas smell—Extinguish any and all open flames and open windows.
2. Turn gas off—Service range with gas turned off unless testing requires it.
3. Checking for gas leaks—Never check for leaks with any kind of open flame. Soap and water solution should be used for this purpose. Apply solution to suspected area and watch for air bubbles which indicates a leak. Correct leaks by tightening fittings, screws, connections, applying approved compound, or installing new parts.
4. Using lights—Use a hand flashlight when servicing ranges or checking for gas leaks. Electric switches should not be operated where leaks are suspected. This will avoid creating arcing or sparks which could ignite the gas. If electric lights are already turned on, they should not be turned off.
5. Do not smoke—Never smoke while servicing gas ranges, especially when working on piping that contains or has contained gas.
6. Check range when service is completed—After servicing, make visual checks on electrical connection, and check for gas leaks. Inform consumer of the condition of range before leaving.
7. Adhere to all local regulations and codes when performing service.

Receiving Oven

- Installer needs to show consumer location of the range gas shut-off valve and how to shut it off.
- Authorized servicer must install the range, in accordance with the Installation Instructions. Adjustments and service should be performed only by authorized servicer.
- Plug range into a 120-volt grounded outlet only. Do not remove round grounding prong from the plug. If in doubt about grounding of the home electrical system, it is consumers responsibility and obligation to have an ungrounded outlet replaced with a properly grounded three-prong outlet in accordance with the National Electrical Code. Do not use an extension cord with this appliance.
- Insure all packing materials are removed from the range before operating it, to prevent fire or smoke damage should the packing material ignite.
- Ensure range is correctly adjusted by a qualified service technician or installer for the type of gas (Natural or LP). Some ranges can be converted for use with Natural or LP gas.
- With prolonged use of a range, high floor temperatures could result. Many floor coverings will not be able to withstand this kind of use. Never install range over vinyl tile or linoleum that cannot withstand high temperatures. Never install range directly over carpeting.

Important Safety Information

Connecting Range to Gas

Install manual shut-off valve in gas line for easy accessibility outside range. Be aware of the location of the shut-off valve.

Extension Cords

Do not use an extension cord with this product.

Using the Oven

- Do not leave children alone or unattended where a range is hot or in operation. They could be seriously burned.
- Do not allow anyone to climb, stand or hang on the door. They could damage the range and cause severe personal injury.
- Wear proper apparel. Loose fitting or hanging garments should never be worn when using oven. Flammable material could ignite if brought in contact with flame or hot oven surfaces which may cause severe burns.
- Never use range for warming or heating a room. This may cause burns, injuries, or a fire.
- Do not use water on grease fires.
- Do not let grease or other flammable materials collect in or around range.
- Do not repair or replace any part of range unless it is recommended in this manual.
- Use only dry potholders. Moist or damp potholders used on hot surfaces may result in a burn from steam. Do not let a potholder touch the flame. Do not use a towel or a bulky cloth as a potholder.
- Never leave range unattended while cooking. Boilovers can cause smoking and may ignite.
- Only certain types of glass/ceramic, earthenware, or other glazed utensils are suitable for oven use. Unsuitable utensils may break due to sudden temperature change.
- Use care when opening oven door. Let hot air or steam escape before removing or replacing food.
- Do not heat unopened food containers in oven. Build-up of pressure may cause a container to burst and result in injury.
- Keep range vent ducts unobstructed.
- Place oven racks in desired location while oven is cool. If a rack must be moved while oven is hot, use a dry potholder.
- Do not use aluminum foil to line oven bottom or racks. Aluminum foil can cause a fire will seriously affect baking results, and damage to porcelain surface's.
- Do not touch interior surfaces of oven during or immediately after use. Do not let clothing or other flammable materials come in contact with bake or broil burners.
- Other areas of the oven can become hot enough to

cause burns, such as vent openings, window, oven door and oven racks.

- To avoid steam burns, do not use a wet sponge or cloth to wipe up spills on hot cooking area.
- Do not store combustible or flammable materials, such as, gasoline or other flammable vapors and liquids near or in oven.
- Do not clean oven door gasket located on back of the door. Gasket is necessary to seal the oven and can be damaged as a result of rubbing or being moved.
- Do not drape towels or any materials on oven door handles. These items may ignite causing a fire.

OVENS

1. Use Care When Opening Door—Let hot air or steam escape before removing or replacing food.
2. Do Not Heat Unopened Food Containers—Buildup of pressure may cause container to burst and result in injury.
3. Keep Oven Vent Ducts Unobstructed.
4. Placement of Oven Racks—Always place oven racks in desired location while oven is cool. If rack is removed while oven is hot, do not let potholder contact hot heating element in oven.

SELF-CLEANING OVENS

1. Do Not Clean Door Gasket—The door gasket is essential for a good seal. Care should be taken not to rub, damage, or move the gasket.
2. Do Not Use Oven Cleaners—No commercial oven cleaner or oven liner protective coating of any kind should be used in or around any part of the liner.
3. Clean Only Parts Listed in Manual.
4. Before Self-Cleaning the Oven—Remove broiler pan, oven racks, and other utensils.
5. Remove all items from range top and backguard.

GLASS/CERAMIC COOKING SURFACES

1. Do Not Cook on Broken Cooktop—If cooktop should break, cleaning solutions and spillovers may penetrate the broken cooktop and create a risk of electrical shock. Contact a qualified technician immediately.
2. Clean Cooktop With Caution—If a wet sponge or cloth is used to wipe spills on a hot cooking area, be careful to avoid a steam burn. Some cleaners can produce fumes if applied to a hot surface.

VENTILATION HOODS

1. Clean Ventilation Hoods Frequently—Grease should not be allowed to accumulate on hood or filter.
2. When flaming foods under hood, turn fan off. The fan, if operating, may spread the flame.

Due to the nature of cooking, fires can occur as a result of over cooking or excessive grease. Though a fire is unlikely, if one occurs, proceed as follows:

Surface Element Fire

1. Smother the fire with a nonflammable lid or baking soda, or use a Class ABC or BC extinguisher. Not water. Not salt. Not flour.
2. As soon as it is safe to do so, turn the surface controls to "OFF".

Oven Fires

1. If you see smoke from your oven, do not open oven door.
2. Turn oven control to "OFF".
3. As an added precaution, turn off power at main circuit breaker or fuse box.
4. Turn on vent to remove smoke.
5. Allow food or grease to burn itself out in oven. Do not open oven door.
6. If smoke and fire persist, call fire department.
7. If there is any damage to components, call an authorized servicer.

Precautions

- Do not cook food directly on range top surface, always use cookware.
- Do not mix household cleaning products. Chemical mixtures may interact with objectionable or even hazardous results.
- Do not put plastic items on warm cooking areas. They may stick and melt.
- Do not slide rough objects across range top surface. Scratching or metal marking can result.
- Do not use cookware with rough bottoms. They may scratch smoothtop surface. Glass and ceramic cookware should not be used.
- Do not use damp sponge or dishcloth to clean range top. A film of soil-laden detergent water may collect on range top. If this should happen, Amana Cleaning Conditioning Cream removes this type of stain.
- Do not leave fat heating unless you remain nearby. Fat can ignite if overheated by spilling onto hot surfaces.
- Do not allow pots to boil dry as this can cause damage to cooking surface and pan.
- Do not use range top surface as a cutting board.
- Do not use range for storage or as a display counter.

Product Safety Devices

Safety devices and features have been engineered into the product to protect consumer and servicer. Safety devices must never be removed, bypassed, or altered in such a manner as to defeat the purpose for which they were intended.

Listed below are various safety devices together with the reason each device is incorporated in the gas ranges.

Pressure Regulator

Maintains proper/steady gas pressure oven controls. Regulator must be set for the type of gas being used, either **Natural** or **LP**.

After servicing regulator, make certain it is set properly before completing service.

Gas Burner Orifices

Universal orifices are used on most valves. They must be adjusted or set for the type of gas being used **Natural** or **LP**.

After servicing a valve or orifice verify it is adjusted properly before completing service.

Grounded Oven Frame

Ground prong on power cord is connected to the frame, usually a green lead fastened by a screw. In addition, any part or component capable of conducting an electric current is grounded by its mounting.

If any ground wire, screw, strap, nut, etc. is removed for service, or any reason, it must be reconnected to its original position with original fastener before the appliance is put into operation again.

Failure to do so can create a possible shock hazard.

General Information

This manual provides basic instructions and suggestions for handling, installing and servicing dual fuel ranges.

The directions, information, and warnings in this manual are developed from experience with, and careful testing of the product. If the unit is installed according to this manual, it will operate properly and will require minimal servicing. A unit in proper operating order ensures the consumer all the benefits provided by clean, modern gas cooking and electric baking.

This manual contains information needed by authorized service technicians to install and service dual fuel ranges. There may be, however, some parts which need further explanation. Refer to the Installation Instructions, Use and Care, Technical Sheets or the toll-free technical support line.

Cooking Nomenclature

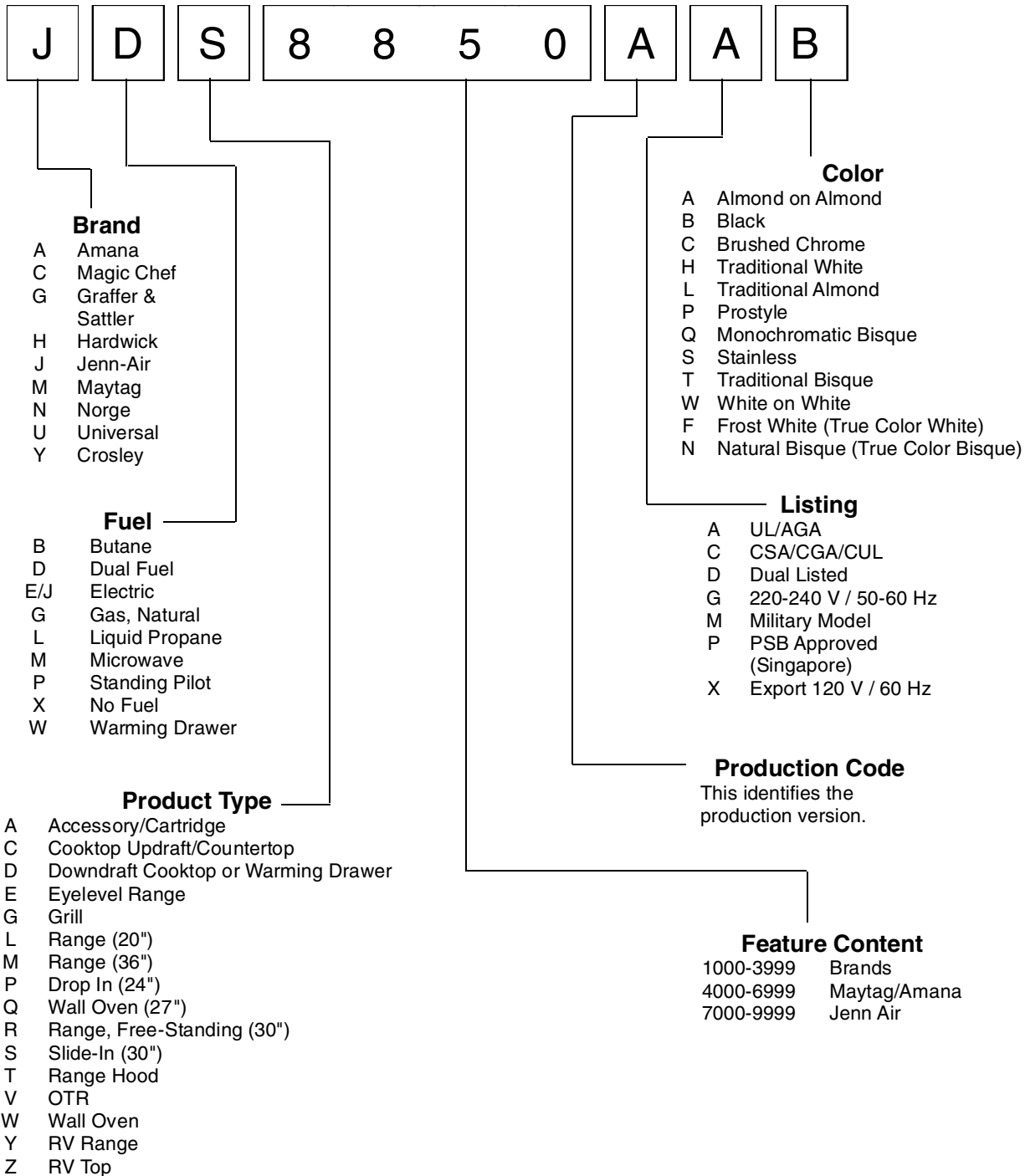

General Information

Specifications

Refer to individual Technical Sheet for specification information.

Placement of the Oven

This freestanding range must be placed in the kitchen or comparable room. All safety guidelines must be followed (see Chapter 2) and free air flow around the range is essential.

Do Not Block Air Vents

All air vents must be kept clear during cooking. If air vents are covered during operation, the oven may overheat. If this occurs, a sensitive, thermal safety device automatically removes power to the oven, rendering the oven inoperable. The oven will remain in this state until it has sufficiently cooled.

Location of Model Number

To request service information or replacement parts, the service center will require the complete model, serial, and manufacturing number of your freestanding range. The number can be found on a metal tag located on the back of the control panel. Reach behind the top left corner of the control panel and rotate the tags up to view the data.

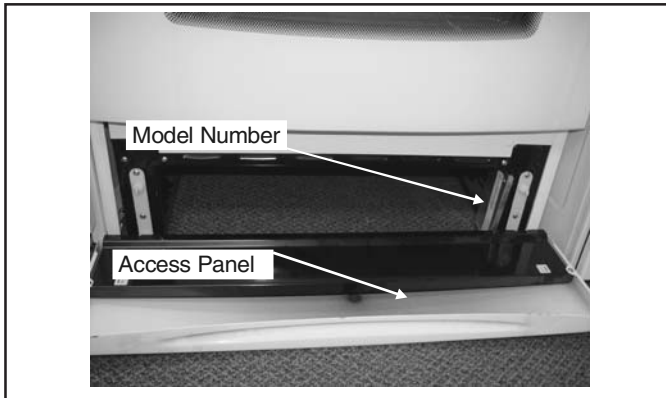

Model Identification

Complete enclosed registration card and promptly return.

If registration card is missing:

- For Jenn-Air product call 1-800-536-6247 or visit the Web Site at www.jennair.com
- For product in Canada call 1-866-587-2002 or visit the Web Site at www.jennair.com

When contacting provide product information located on rating plate. Record the following:

Model Number: _____
Manufacturing Number: _____
Serial or S/N Number: _____
Date of purchase: _____
Dealer's name and address: _____

Service

Keep a copy of sales receipt for future reference or in case warranty service is required. To locate an authorized servicer:

- For Jenn-Air product call 1-800-462-9824 or visit the Web Site at www.jennair.com
- For product in Canada call 1-866-587-2002 or visit the Web Site at www.jennair.com

Warranty service must be performed by an authorized servicer. We also recommend contacting an authorized servicer, if service is required after warranty expires.

Parts and Accessories

Purchase replacement parts and accessories over the phone. To order accessories for your product call:

- For Jenn-Air product call 1-800-462-9824 or visit the Web Site at www.jennair.com
- For product in Canada call 1-866-587-2002 or visit the Web Site at www.jennair.com

Extended Service Plan

We offer long-term service protection for this new oven.

- Dependability PlusSM Extended Service Plan is specially designed to supplement Jenn-Air's strong warranty. This plan covers parts, labor, and travel charges.

Call 1-800-925-2020 for information.

Range Description

Range Description

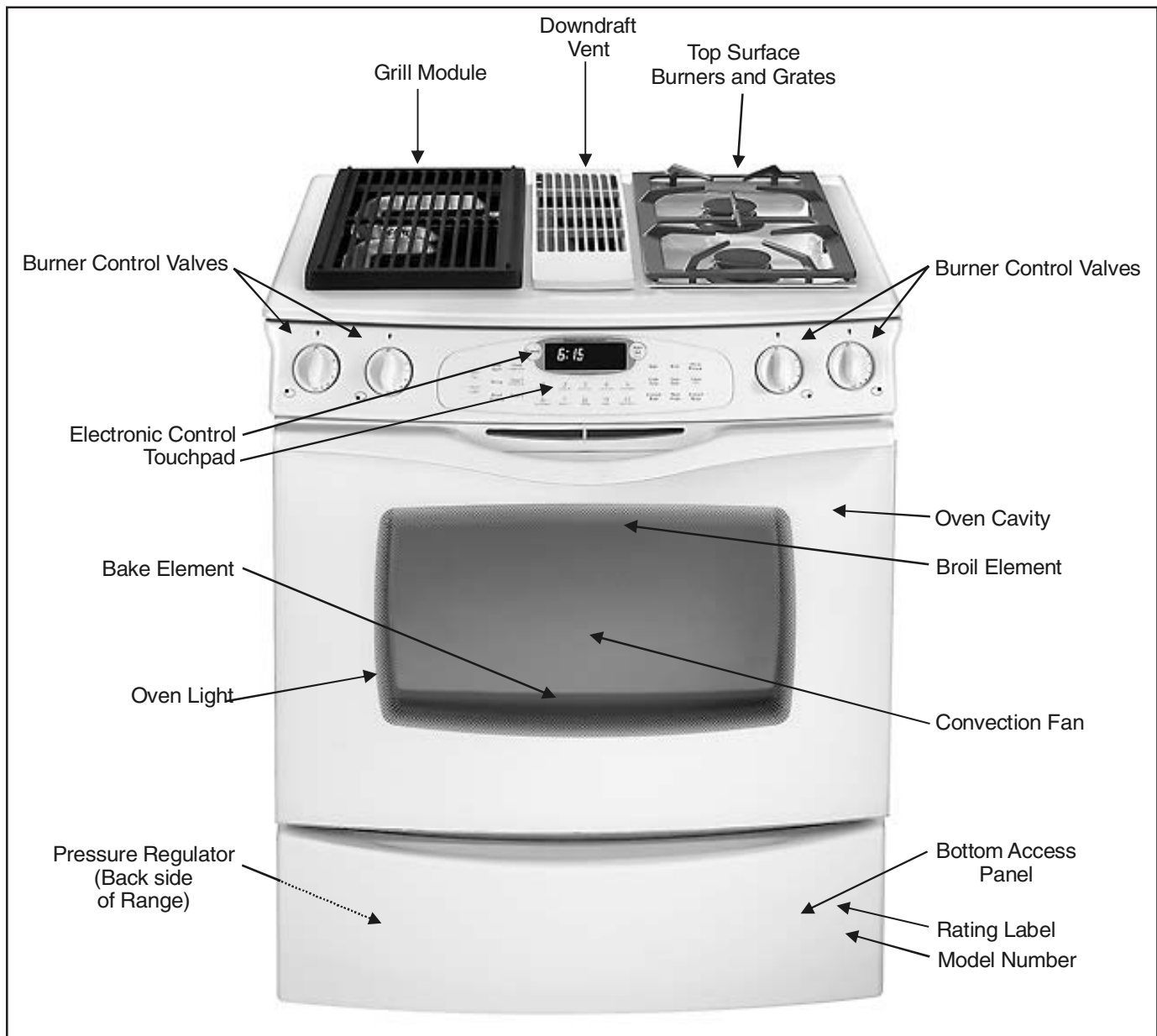

Troubleshooting Procedures



WARNING

To avoid risk of electrical shock, personal injury, or death, disconnect power and gas to oven before servicing, unless testing requires power and/or gas.

Troubleshooting Chart

Problem	Possible Cause	Correction
Burners will not ignite; no spark at top burner.	Poor ground on burner cap Weak or failed spark module..... Low gas pressure..... Clogged burner port	<ul style="list-style-type: none"> • Clean burner cap. • Replace spark module. • Verify pressure 4" WCP for natural, 10" WCP for LP. • Clean burner cap.
Burner will not ignite. No spark to burner ignitors when burner knob is rotated to "LITE" position.	No 120 VAC to range Micro switch contacts not closing..... Faulty wiring. Bad connection at burner electrode and electrode socket Inoperative spark module..... Electrode dirty. Burner cap dirty..... Cracked or broken electrode, electrode wire or electrode socket	<ul style="list-style-type: none"> • Verify voltage at wall outlet. • Check wiring against appropriate wiring diagram. Verify all terminals and connections are correct and tight. Check micro switch contacts. • Check wiring against appropriate wiring diagram. Verify all terminals and connections are correct and tight. • Check module according to testing procedures information. • Clean electrode or burner cap. • Replace electrode.
No spark or only random spark at one ignitor.	Check for cracked ignitor or pinched ignitor wire Poor continuity to burner cap Bad ground connection or lack of continuity to ground or ignitor..... Cracked or broken ignitor extension lead.....	<ul style="list-style-type: none"> • Replace ignitor lead or electrode. • Clean burner cap and lead. • Tighten ground connection and correct any breaks in ground path from ignitor path to unit ground path. • Replace ignitor lead.
Unit continues to spark after knob is turned to OFF position.	Shorted valve switch/harness Switch has slipped off the valve	<ul style="list-style-type: none"> • Replace switch/harness. If shorting is caused by excessive spillovers, customer education is advised. • Carefully reposition switch on valve and rotate from OFF to high, several times to verify switch is not broken.
No oven operation in bake or broil.	No voltage to control. No voltage from control Loose wire connection or broken wire.....	<ul style="list-style-type: none"> • Check for 120 VAC at control. If no voltage check power source. • Check 120 VAC to ignitor, if no voltage, replace control. • Verify all connections are clean and tight, replace broken wire.
No bake element operation	Open bake element..... Loose wire connection or broken wire..... Open bake relay.....	<ul style="list-style-type: none"> • Check element for continuity, replace if failed. • Verify all connections are clean and tight, replace broken wire. • Verify 240 VAC at bake element.

Troubleshooting Procedures



WARNING

To avoid risk of electrical shock, personal injury, or death, disconnect power and gas to oven before servicing, unless testing requires power and/or gas.

Problem	Possible Cause	Correction
No broil element operation	Open broil element Loose wire connection or broken wire..... Open broil relay	<ul style="list-style-type: none"> • Check element for continuity, replace if failed. • Verify all connections are clean and tight, replace broken wire. • Verify 240 VAC at broil element.
No gas flows to burner. Ignitor glows red.	Failed ignitor..... Gas pressure too high	<ul style="list-style-type: none"> • Check ignitor current draw, 3.2 – 3.6 Amps. Replace ignitor, if it fails test. • Check for correct gas pressure. Natural gas pressure should be 4" WCP and LP gas pressure should be 10" WCP.
	Failed gas valve	<ul style="list-style-type: none"> • Check gas valve for continuity.
	Loose wire connection or broken wire.....	<ul style="list-style-type: none"> • Verify all connections are clean and tight, replace broken wire.
Fan motor does not operate.	No power to fan motor..... Failed fan motor or winding/frozen shaft.....	<ul style="list-style-type: none"> • Check for 120 VAC supplied at fan motor. If no voltage is present, check for broken or loose wiring between fan motor and relay board. If voltage is present at fan motor, go to the next step. • Check motor winding for continuity. Check for a frozen motor shaft. Check for broken wiring between motor and neutral terminal block.
Oven smokes/odor first few times of usage.	Normal.....	<ul style="list-style-type: none"> • Minor smoking and/or odor is normal the first few times of oven usage.
Failure Codes.	Electronically Controlled.....	<ul style="list-style-type: none"> • See "Fault Code Chart."
Oven not operating.	Programming error	<ul style="list-style-type: none"> • Switch circuit breaker off to oven for five minutes and try oven again.
	Power outage	<ul style="list-style-type: none"> • Verify power is present at unit and circuit breaker is not tripped. • Replace household fuse, but do not fuse capacity.
	Unit in Sabbath mode.....	<ul style="list-style-type: none"> • Refer to Use & Care manual and remove unit from Sabbath mode.
Clock and timer not working.	Power outage	<ul style="list-style-type: none"> • Verify power is present at unit and circuit breaker is not tripped. • Replace household fuse, but do not fuse capacity.
	Electronic Control locked.....	<ul style="list-style-type: none"> • Refer to Use and Care manual and unlock electronic control.
Oven light does not operate.	Failed oven lamp	<ul style="list-style-type: none"> • Check lamp and replace is necessary.
	Failed wiring	<ul style="list-style-type: none"> • Check for broken, loose or dirty connections.
	Failed light socket.....	<ul style="list-style-type: none"> • Check light socket for continuity.

Troubleshooting Procedures



WARNING

To avoid risk of electrical shock, personal injury, or death, disconnect power and gas to oven before servicing, unless testing requires power and/or gas.

Problem	Possible Cause	Correction
Oven door will not unlock.	Oven is self-cleaning Oven is still hot	<ul style="list-style-type: none"> • Allow cycle to complete. • Will not unlock until unit has cooled to safe temperature. Do not force door open, this will void warranty. Blow cool air on door latch area to quicken process.
Self-clean cycle not working.	Programming error Door lock	<ul style="list-style-type: none"> • Turn off circuit breaker for five minutes and try oven again. • Verify door lock energizes & engages.

Fault Code Chart

Fault Code	Description	Component to Troubleshoot/Replace
F0-0	No Fault.....	• None.
F1-1	Oven temperature above 650° F (343° C) in bake mode	• Ohm sensor and harness (see "Oven Sensor" chart). If OK, change control.
F1-3	Oven temperature above 950° F (510° C) during a clean cycle	• Ohm sensor and harness (see "Oven Sensor" chart). If OK, change control.
F1-5	Cancel pad not responding	• Ensure ribbon cable is securely connected, inspect ribbon cable and connector (shorts, breakage, corrosion, etc.). If OK, replace control.
F1-7	Membrane disconnected.....	• Ensure ribbon cable is securely connected, inspect ribbon cable and connector (shorts, breakage, corrosion, etc.). If OK, replace control.
F1-8	Shorted key (pad) in membrane switch .	• Ensure ribbon cable is securely connected, inspect ribbon cable and connector (shorts, breakage, corrosion, etc.). If OK, replace control.
F1-9	Internal control communication errors....	• Replace control.

Troubleshooting Procedures



WARNING

To avoid risk of electrical shock, personal injury, or death, disconnect power and gas to oven before servicing, unless testing requires power and/or gas.

Fault Code	Description	Component to Troubleshoot/Replace
F1-A	Lock/unlock switch state not advancing to control	<ul style="list-style-type: none"> • Check connections, harness, and motor. If OK, replace control.
F1-C	Oven door switch state not advancing to control.....	<ul style="list-style-type: none"> • Check connections, harness, and motor. If OK, replace control.
F1-E	Control not calibrated	<ul style="list-style-type: none"> • Replace control.
F1-F	Jumper not removed from printed circuit board (PCB)	<ul style="list-style-type: none"> • Remove jumper from PCB.
F1-H	EEPROM error	<ul style="list-style-type: none"> • Replace control.
F1-N	Internal voltage for slave incorrect	<ul style="list-style-type: none"> • Replace control.
F3-1	Open or shorted sensor.....	<ul style="list-style-type: none"> • Ohm sensor and harness.
F8	Shorted meat probe.....	<ul style="list-style-type: none"> • Check probe jack and harness probe jack harness. If OK, check meat probe (see "Meat Probe" chart).
F9-1	Oven door will not lock	<ul style="list-style-type: none"> • Check wire connections. If OK, replace motorized door lock.
F9-2	Oven door will not unlock	<ul style="list-style-type: none"> • Check wire connections. If OK, replace motorized door lock.
F9-3	Oven door status is both locked and unlocked	<ul style="list-style-type: none"> • Check wire connections. If OK, replace motorized door lock.

Troubleshooting Procedures



WARNING

To avoid risk of electrical shock, personal injury, or death, disconnect power and gas to oven before servicing, unless testing requires power and/or gas.

Oven Sensor and Meat Probe Charts

OVEN SENSOR	
Sensor Type: RTD 1000 Ω platinum	
Calibration: 1654 Ω (350° F/177° C)	
Temperature F (C)	Resistance (Ohms)
100 (38)	1143
200 (94)	1350
300 (149)	1553
350 (177)	1654
400 (204)	1753
500 (260)	1949
600 (316)	2142
700 (371)	2331
800 (427)	2516
900 (483)	2697
1000 (538)	2874

MEAT PROBE	
Type: NTC Thermistor	
Calibration: 9938 Ω (150° F/65.5° C)	
Temperature F (C)	Resistance (Ohms)
122 (50)	18963
150 (65.5)	9938
156.2 (69)	8846
165.2 (74)	7456
210.1 (98.9)	3886





Testing Procedures

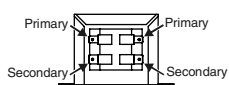
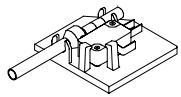
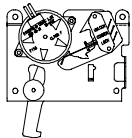
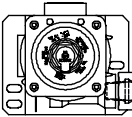
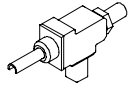

WARNING

To avoid risk of electrical shock, personal injury or death; disconnect power to oven before servicing, unless testing requires power.

Component Testing Procedures

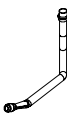
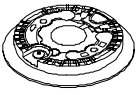
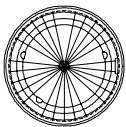
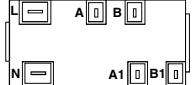
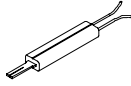
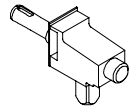
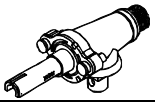



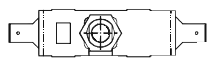
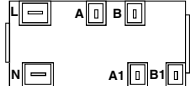

Illustration	Component	Test Procedure	Results
	Oven light housing All models	Disconnect connector and test resistance of terminals..... Measure voltage at oven light.....	Verify bulb is plugged in properly. Indicates continuity with bulb installed. 12 VAC, see wiring diagram for terminal identification. If no voltage is present at oven light, check wiring or light switches.
	Step-down transformer All models	Measure voltage at: Primary terminals Secondary terminals	120 VAC (tolerance: 108 to 127 VAC) 10W load (bulb): 11.4 to 11.8 VAC 20W load (bulb): 10.8 to 11.4 VAC
	Door plunger switch All models	Remove switch from unit and measure the following points: COM to NO	Plunger in continuity, plunger out infinity.
	Autolatch assembly All models	Disconnect wires and test for continuity per wiring diagram..... Refer to Parts Manual for correct autolatch switch associated with the correct manufacturing number.	See wiring diagram for schematic layout. Access assembly by removing two screws from the front and lowering control panel. Common is in neutral position unless locking or unlocking autolatch assembly.
	Pressure regulator	Verify gas pressure (W.C.P.)..... If on LP service verify proper gas supply conversion.	5" Natural 10" LP/propane
	270° valve 6.5 K btu 9.1 K btu 10.5 K btu 12 K btu Model JDS8850A**	Verify gas is supplied. Adjust set screw for simmer control.	
	Spark switch Model JDS8850A**	Test for voltage at terminals Disconnect wiring and check for continuity in LITE position.....	120 VAC Continuity in LITE position.
	Spark ignition electrode Model JDS8850A**	Test for resistance of spark lead Test ignitor to chassis.....	Continuity No continuity from ignitor to chassis.
	Venturi, right front, left front, left rear burners Model JDS8850A**	Shutter settings	Nominal: .038" (tolerance: .035" to .041")
	Venturi, right rear burner Model JDS8850A**	Shutter settings	Nominal: .038" (tolerance: .035" to .041")

Testing Procedures



WARNING

To avoid risk of electrical shock, personal injury or death; disconnect power and gas to oven before servicing, unless testing requires power and/or gas.

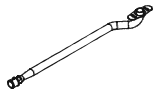

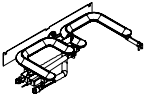
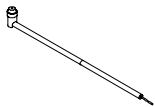

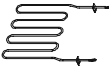

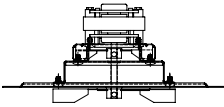
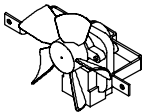

Illustration	Component	Test Procedure	Results
	Top surface burner 6.5 K btu, 9.1 K btu 10.5 K btu 12 K btu Model JDS8850A**	Verify gas is supplied Verify burner cap is positioned correctly.	Check for obstructions in burner ports.
	Top surface burner cap Model JDS8850A**	Verify cap is positioned correctly	Check for obstructions in burner ports.
	Spark module 4 + 0 Model JDS8850A**	Test for voltage at terminals L and N.. Check polarity and ground.....	120 VAC (tolerance: 109 to 125 VAC) See wiring diagram
	Ignitor Model JDS8850A**	Test for voltage at terminals Test for the amount of amperage in the circuit..... (Ignitor may glow but not have sufficient amperage to open valve).	120 VAC. 3.2 – 3.6 Amps If not replace.
	Burner valve, left, 360° Model JDS9860A**	Verify gas is supplied. Orifice adjusted for Natural or LP. Adjust set screw for simmer control....	To replace burner valve(s), complete assembly must be replaced (manifold and valves). 16,000 BTU per hour minimum. See conversion section.
	Burner valve, left and right, 180° Model JDS9860A**	Verify gas is supplied. Orifice adjusted for Natural or LP	To replace burner valve(s), complete assembly must be replaced (manifold and valves).
	Shut-off valve Model JDS9860A**	Verify gas is turned on.....	Gas ONend slot is vertical. Gas OFF ..end slot is horizontal.
	Spark switch Model JDS8850A**	Test for voltage at terminals Disconnect wiring and check for continuity in LITE position.....	120 VAC Continuity in LITE position.
	Double valve switch Model JDS9860A**	Test for voltage at terminals Disconnect wiring and check for continuity in LITE position.....	120 VAC Continuity in LITE position.
	Snap switch Model JDS9860A**	Test for voltage at terminals Disconnect wiring and check for continuity in LITE position.....	120 VAC Continuity in LITE position.
	Spark module 4 + 0 Model JDS9860A**	Test for voltage at terminals L and N..... Check polarity and ground.....	120 VAC. See wiring diagram.
	Venturi, front (short) Model JDS9860A**	Nominal air shutter setting..... Tolerance375 3/8" .030 1/32"

Testing Procedures



WARNING

To avoid risk of electrical shock, personal injury or death; disconnect power and gas to oven before servicing, unless testing requires power and/or gas.

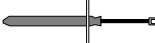
Illustration	Component	Test Procedure	Results
	Venturi, rear (long) Model JDS9860A**	Nominal air shutter setting..... Tolerance375 3/8" .030 1/32"
	Tube, front (short) Model JDS9860A**	Nominal air shutter setting..... Tolerance250 1/4" .031 1/32" (approx.)
	Tube, rear (long) Model JDS9860A**	Nominal air shutter setting..... Tolerance585 19/32" (approx.) .031 1/32" (approx.)
	E-burner grill assembly Model JDS9860A**	Verify gas is supplied	Check for obstructions in burner ports.
	E-burner ignitor Model JDS9860A**	Test for resistance of spark lead Test ignitor to chassis.....	Continuity. No continuity from ignitor to chassis.
	Bake element	Disconnect wiring to element and measure cold resistance of terminals..... Measure voltage at bake element	Approx. 20.6 to 22.6 Ω. 240 VAC.
	Broil element	Disconnect wiring to element and measure cold resistance of terminals..... Measure voltage at broil element	Approx. 13.3 to 14.7 Ω. 240 VAC.
	Hi-limit temperature switch	Normally closed, verify operation: Open: 269° to 291°F (132° to 144°C) Closed: 173° to 207°F (78° to 97°C).	Infinite. Continuity.
	Convection assembly Convection motor	Measure voltage..... Check motor windings to ground.....	120 VAC. (tolerance: 105 to 135 VAC) No continuity. RPM: Approx. 1750 to 2250.
	Cooling fan motor	Measure voltage..... Check motor windings to ground.....	120 VAC. No continuity. RPM: Idle: 3395 Load: 3000 Breakdown: 2400
	Downdraft motor Model JDS9860A**	Measure voltage..... Check motor windings to ground.....	120 VAC. No continuity. RPM: 1550, 2.4 amp
	Temperature sensor	Measure resistance	Approx 1100 Ω at room temperature 75° F (23.8° C).

Testing Procedures



WARNING

To avoid risk of electrical shock, personal injury or death; disconnect power and gas to oven before servicing, unless testing requires power and/or gas.



WARNING

To avoid risk of electrical shock, personal injury or equipment failure, use extreme caution when taking voltage measurements in the Electronic Control. Failure to do so could short-circuit the control or result in electrical shock.

Illustration	Component	Test Procedure	Results
	Electronic control	Door logic sensor	P11 (Red, pin 5) to P11 (Black, pin 2): Door Locked: Continuity Door Unlocked: Infinity
		Meat probe	P2 (Red) to P2 (Red). See "Meat Probe" chart.
		Downdraft motor high setting.....	P14 (Tan) to P5 (White): 120 VAC
		Downdraft motor low setting.....	P22 (Orange) to P5 (White): 120 VAC

Oven Control Testing Procedures

- Changing factory set default options:
1. Press **Setup Options** and the desired pad simultaneously (see table).
 2. Press **Autoset** to change the option.
 3. Press any pad except **Cancel** to accept the change.
 4. Press **Cancel** to cancel the operation.

Control	Component	Test Procedure	Results
EOC II	Oven temperature adjustment	Press Bake pad and enter 550° F (288° C). Press and hold Bake pad until TEMP ADJ displays. Press Autoset pad to adjust oven in 5° F (-15° C) increments, from -35° F (-37° C) to 35° F (2° C).	While increasing or decreasing oven temperature, this does not affect self-cleaning temperature.
EOC II	End-of-Timer Reminder beeps	Press Setup Options and the applicable timer pad (Timer 1 or Timer 2) simultaneously.	Selects the number of beeps emitted when a timed bake cycle ends.
EOC II	Control Lock	Press Setup Options and the Control Lock pad (also the 1 pad) simultaneously.	Press Autoset to select option (enable/disable). The timer, clock and oven light remain operational.
EOC II	Twelve Hour off/Sabbath mode	Press Setup Options and the 12 Hour Off pad (also the 2 pad) simultaneously.	Disables the normal 12-hour shutoff, allowing the oven to operate indefinitely.
EOC II	Sound Level (Beeper Volume)	Press Setup Options and the Sound Level pad (also the 3 pad) simultaneously.	Press Autoset to select setting (I lowest through IIIIIIIII 8 highest).
EOC II	24-Hour Clock	Press Setup Options and the 12/24 Hour Clock pad (also the 4 pad) simultaneously.	Press Autoset to select option (12-hour time or 24-hour time).
EOC II	Scroll Speed	Press Setup Options and the Scroll Speed pad (also the 5 pad) simultaneously.	Press Autoset to set speed of displayed messages (slow, medium, fast).
EOC II	End-of-Cook-Time Signal	Press Setup Options and Cook Time Beeps pads (also the 6 pad) simultaneously.	Press Autoset to set the number of beeps emitted at the end of a "clock-controlled" cook cycle.
EOC II	Temperature Display	Press Setup Options and the Temp C/F pad (also the 7 pad) simultaneously.	Press Autoset to select option (°F or °C).
EOC II	Language Display	Press Setup Options and the Language pad (also the 8 pad) simultaneously.	Press Autoset to select option (English, French or Spanish).
EOC II	Factory Default	Press Setup Options and the Default pad (also the 9 pad) simultaneously.	Press Autoset to reset clock to factory settings.
EOC II	Clock Display	Press Setup Options and the Display On/Off pad (also the Clock pad) simultaneously.	Press Autoset to select clock display (on or off).
EOC II	Test Access	Press and hold Cancel and Broil pads for 3 seconds at power up or within 5 minutes of power up mode. See "Quick Test Mode."	Allows access to each function for testing purposes.

Testing Procedures



WARNING

To avoid risk of electrical shock, personal injury or death; disconnect power and gas to oven before servicing, unless testing requires power and/or gas.

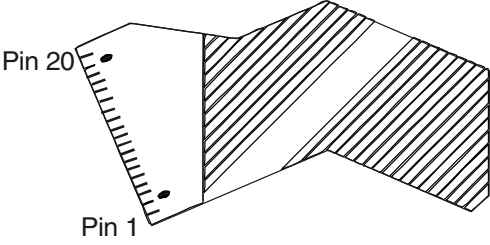
Component	Test Procedure	Results		
		Pad	Trace	Measurement
Control Panel Assembly	<p>Closed circuitry resistance (defined as continuity): 1350 – 2250 Ω for Cancel pads 1 & 20 1275 – 2125 Ω for Cancel pads 2 & 19 320 – 2200 Ω for all other pads Open circuitry resistance: Greater than 10 MΩ</p> 	1	7 & 8	Continuity
		2	14 & 15	Continuity
		3	10 & 14	Continuity
		4	6 & 7	Continuity
		5	6 & 8	Continuity
		6	5 & 6	Continuity
		7	4 & 5	Continuity
		8	4 & 6	Continuity
		9	3 & 4	Continuity
		0	3 & 6	Continuity
		Cancel	1 & 2 <i>or</i>	Continuity
			1 & 19 <i>or</i>	Continuity
			2 & 20 <i>or</i>	Continuity
			19 & 20	Continuity
		Clock	13 & 14	Continuity
		Quick Preheat	16 & 18	Continuity
		Bake	15 & 16	Continuity
		Broil	16 & 17	Continuity
		Keep Warm	12 & 13	Continuity
		Convect Warm	6 & 10	Continuity
		Convect Roast	3 & 18	Continuity
		Cook Time	10 & 18	Continuity
		Stop Time	14 & 18	Continuity
		Clean	15 & 18	Continuity
		Proofing	8 & 10	Continuity
		Drying	9 & 10	Continuity
		Meat Probe	6 & 18	Continuity
		Vent Fan	11 & 12	Continuity
Auto Set	17 & 18	Continuity		
Timer 1	12 & 14	Continuity		
Timer 2	10 & 12	Continuity		
Oven Light	10 & 11	Continuity		

Testing Procedures



WARNING

To avoid risk of electrical shock, personal injury or death; disconnect power and gas to oven before servicing, unless testing requires power and/or gas.

Relay Logic

NOTE: Subsequent changes implemented after the release of this technical sheet may have altered the parameters identified in this chart.

COOKING MODE	BAKE	BROIL	CONVECT FAN HI SPEED	CONVECT FAN LO SPEED	OVEN LIGHT
IDLE	X	X	X	X	◇
BAKE PREHEAT	■	■	X	X	◇
BAKE	■	■	X	X	◇
HIGH BROIL PREHEAT	X	O	X	X	◇
HIGH BROIL	X	O	X	X	◇
LOW BROIL PREHEAT	X	■	X	X	◇
LOW BROIL	X	■	X	X	◇
CLEAN PREHEAT	X	O	X	X	X
CLEAN	O	X	X	X	X
KEEP WARM PREHEAT	■	X	X	X	◇
KEEP WARM	■	X	X	X	◇
CONVECT ROAST PREHEAT	■	■	O*	X	◇
CONVECT ROAST	■	■	O*	X	◇
CONVECT BAKE QUICK PREHEAT	■	■	X	O*	◇
CONVECT BAKE PREHEAT	■	■	X	O*	◇
CONVECT BAKE	■	■	X	O*	◇
QUICK PROOFING PREHEAT	■	■	X	O*	◇
QUICK PROOFING	■	■	X	O*	◇
STANDARD PROOFING PREHEAT	■	■	X	X	◇
STANDARD PROOFING	■	■	X	X	◇
DRYING PREHEAT	■	■	O*	X	◇
DRYING	■	■	O*	X	◇
INDEX					
X - OFF					
O - ON					
■ - CYCLING					
◇ - ON OR OFF (DETERMINED BY USER INPUT)					

*Convection fan stops when oven door is opened.

Testing Procedures



WARNING

To avoid risk of electrical shock, personal injury or death; disconnect power and gas to oven before servicing, unless testing requires power and/or gas.

"Quick Test" Mode for Electronic Oven Control (EOC) II

Follow the procedure below to perform the EOC II quick test. Instructions must be entered within 16 seconds of each other (via the touch pad) or the EOC will exit the test mode.

1. **Press and hold** the **Cancel** and **Broil** pads for 3 seconds at power-up, or within 5 minutes of power-up.
2. Once the control has entered the "Quick Test" mode, release both pads.
3. Press each of the following pads indicated in the table below.

NOTE: Press and hold the applicable pad to activate the associated response.
Release the applicable pad to deactivate the associated response.

4. Press **Cancel** to exit the test mode.

The control display window normally displays "lu:d," where the "l" and "u" indicate the state of the motorized door lock and the "d" indicates oven door input status. Once the applicable pad is pressed and held, the "d" changes to either a "0" (open switch) or a "1" (closed switch). Once the pad is released, the display will return to "lu:d."

Display will indicate the following:

<u>Pad</u>	<u>Response</u>
BAKE	Bake relay activated, "1" displayed in control display window.
BROIL	Broil relay activated, "1" displayed in control display window.
CONVECT BAKE	Convection Bake relay activated, Convection Fan cycles, "1" displayed in control display window.
CONVECT ROAST	Convection Roast relay activated, Convection Fan cycles, "1" displayed in control display window.
OVEN LIGHT	Oven light relay activated, "1" displayed in control display window.
PROBE	Actual Probe temperature and "1" displayed in control display window.
TIMER 1	Downdraft fan activated at low speed, "1" displayed in control display window.
TIMER 2	Cooling fan activated, "1" displayed in control display window.
FAN	Downdraft fan activated at high speed, "1" displayed in control display window.
CLEAN	Motorized Door Lock activated, "1" displayed in control display window.
STOP TIME	Beeper activated, "1" displayed in control display window.
COOK TIME	Displays most recent fault code.
TEMPERATURE OFFSET ..	Press Bake pad and enter 550° F (288° C). Press and hold Bake pad for 4 seconds, release Bake pad, then press Bake pad again within 3 seconds. Use the digit pads (0 through 9) to adjust from -35° F (-37° C) to 35° F (2° C), oven in 5° F (-15° C) increments. This also applies to the CLEAN temperature.
CLOCK	Press Setup Options and the 12/24 Hour Clock pad (also the 4 pad) simultaneously, then press Autoset to display time in 12-hour format or 24-hour format.
TEMPERATURE	Press Setup Options and the Temp C/F pad (also the 7 pad) simultaneously, then press Autoset to display degrees in Fahrenheit or Celsius.
CANCEL	Exits the test mode.
0	N/A
1	N/A
2	N/A
3	N/A
4	N/A
5	N/A
6	N/A
7	N/A
8	N/A
9	N/A
AUTOSET	N/A

Testing Procedures



WARNING

To avoid risk of electrical shock, personal injury or death; disconnect power and gas to oven before servicing, unless testing requires power and/or gas.

Description of Fault Codes

Each Fault Code consists of an "F" followed by a number, dash and a number or letter. The following table describes each Fault Code and the component to troubleshoot.

To view the most recent fault code:

1. **Press and hold** the **Cancel** and **Broil** pads for 3 seconds at power-up, or within 5 minutes of power-up.
2. Once the control has entered the "Quick Test" mode, release both pads.
3. Press the **Cook Time** pad to view the most recent fault (displayed in the control display window).

Fault Code	Description	Component to Troubleshoot/Replace
F0-0	No Fault.	None.
F1-1	Oven temperature above 650° F (343° C) in bake mode.	Ohm sensor and harness (see "Oven Sensor" chart). If OK, change control.
F1-3	Oven temperature above 950° F (510° C) during a clean cycle.	Ohm sensor and harness (see "Oven Sensor" chart). If OK, change control.
F1-5	Cancel pad not responding.	Ensure ribbon cable is securely connected, inspect ribbon cable and connector (shorts, breakage, corrosion, etc.). If OK, replace control.
F1-7	Membrane disconnected.	Ensure ribbon cable is securely connected, inspect ribbon cable and connector (shorts, breakage, corrosion, etc.). If OK, replace control.
F1-8	Shorted key (pad) in membrane switch.	Ensure ribbon cable is securely connected, inspect ribbon cable and connector (shorts, breakage, corrosion, etc.). If OK, replace control.
F1-9	Internal control communication errors.	Replace control.
F1-A	Lock/unlock switch state not advancing to control.	Check connections, harness, and motor. If OK, replace control.
F1-C	Oven door switch state not advancing to control.	Check connections, harness, and motor. If OK, replace control.
F1-E	Control not calibrated.	Replace control.
F1-F	Jumper not removed from printed circuit board (PCB).	Remove jumper from PCB.
F1-H	EEPROM error.	Replace control.
F1-N	Internal voltage for slave micro incorrect.	Replace control.
F3-1	Open or shorted sensor.	Ohm sensor and harness.
F8	Shorted meat probe.	Check probe jack and harness probe jack harness. If OK, check meat probe (see "Meat Probe" chart).
F9-1	Oven door will not lock.	Check wire connections. If OK, replace motorized door lock.
F9-2	Oven door will not unlock.	Check wire connections. If OK, replace motorized door lock.
F9-3	Oven door status is both locked and unlocked.	Check wire connections. If OK, replace motorized door lock.

Disassembly Procedures



CAUTION

To avoid risk of electrical shock, personal injury or death; disconnect power to unit before servicing.

Removing and Replacing Range

1. Remove power from unit.
2. Disconnect downdraft blower motor and remove flex ducting to the blower and range (select models).

NOTE: To avoid countertop damage, do not move range forward until range has been raised enough to clear all cabinetry.

3. Pull the range forward out of the cabinet opening.
4. Disconnect or unplug the power cord leading from unit to fuse box or junction box depending on unit.
5. Replace the oven using the installation instructions and anti-tip bracket(s).

Cartridge Assembly (Select Models)

Cooktop cartridges can be installed on either side of the range cooktop.

1. Remove power from unit.
2. Lift up on the tab (located on the cartridge) until top of cartridge clears the opening on the range by 2 inches.

NOTE: Lifting the cartridge too high while still engaged in the receptacle could damage the terminal plug.

3. Hold cartridge by the sides and slide away from terminal receptacle.
4. Lift cartridge out when fully unplugged.

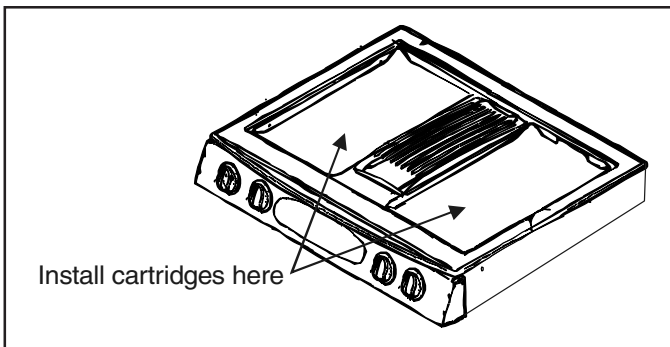

Top Burner

1. Disconnect power before servicing.
2. Remove screws securing burner to burner lower assembly.
3. Reverse procedures to reassemble.

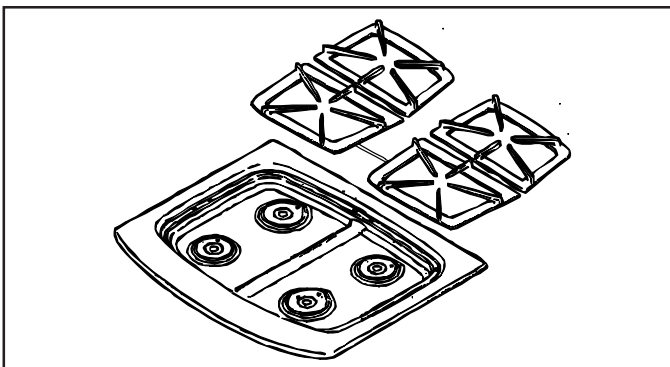

Top Burner Lower Assembly

1. Remove maintop, see "Maintop Removal" procedure. (Perform steps 1 – 7.)
2. Disconnect tubing from lower assembly.
3. Reverse procedures to reassemble.

NOTE: Perform gas leak test.

Manifold and Top Burner

1. Remove maintop, see "Maintop Removal" procedure.

NOTE: If replacing manifold only, skip step 2.

2. Loosen and disconnect fittings securing surface burner tubing to burner assembly and manifold.
3. Remove bolt(s) securing surface valve(s) to manifold.
4. Remove bolt securing shut-off valve from manifold.
5. Disconnect tubing from manifold to the regulator.
6. Reverse procedures to reassemble.

NOTE: Perform gas leak test.

Regulator

1. Disconnect power before servicing.
2. Remove range from installation position, see "Move and/or Replacing Range" procedure.
3. Disconnect tubing from regulator.
4. Remove screws securing bracket to back of unit.
5. Remove screws securing regulator to support bracket.
6. Reverse procedures to reassemble.

NOTE: When reconnecting supply line to regulator use pipe dope compound to seal the connection.

NOTE: Perform gas leak test.

Burner Switch

1. Remove control panel, see "Control Panel" procedure.
2. Disengage burner switch from burner valve and remove switch from valve.
3. Reverse procedure to reinstall burner switch.

Spark Module

1. Remove unit from installation position, see "Removing and Replacing Range" procedure.
2. Remove screws securing lower rear access panel.
3. Disconnect and label wire connections from the spark module.
4. Remove screws securing spark module to unit chassis.
5. Replace and reverse procedure to reassemble.

Disassembly Procedures



CAUTION

To avoid risk of electrical shock, personal injury or death; disconnect power to unit before servicing.

Maintop Assembly

1. Remove power from unit.
2. Remove range from installation position, see "Removing and Replacing Range" procedure.
3. Remove air grill, filter, grill grates, aeration pan and cartridges (select models).
4. Remove screws from plenum area at front of opening.
5. Remove front side trim, see "Remove Front Side Trim" procedure.
6. Remove cartridge receptacles and grill pans (select models).
7. Remove screws around perimeter of unit securing main top to chassis.
8. Label and disconnect wiring to elements (select models).
9. Remove screws securing element mounting brackets to main top assembly (select models).
10. Gently remove elements from mounting brackets to prevent damage to glass top (select models).
11. Reverse procedure to reinstall maintop assembly.

Control Panel

1. Remove power from unit.
2. Remove burner switch control knobs.
3. Open oven door and remove screws securing control panel.
4. Remove screws located on the right and left sides of the control panel.
5. Grasp control panel on the far left and right sides and gently pull the control panel out and down.

NOTE: Gently pull control panel out and down.

6. Remove infinite switch control knobs, infinite switches, indicator lights, rocker switches, and electronic control/clock (as necessary) and transfer to the new control panel.
7. Reverse procedure to reinstall control panel.

Electronic Control

1. Remove control panel, see "Control Panel" procedure, steps 1 through 5.
2. Remove screws securing electronic control bracket to control panel.
3. Label and disconnect terminal wiring from electronic control.
4. Reverse procedure to reinstall electronic control.

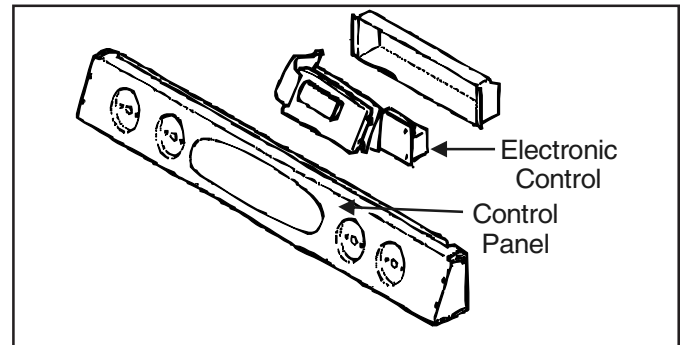

Bottom Access Panel

1. Grasp top of bottom access panel and gently pull down and out.
2. Reverse procedure to reinstall bottom access panel.

Indicator Lights

1. Remove control panel, see "Control Panel" procedure for removal.
2. Label and disconnect wires from indicator light.
3. Squeeze the two tabs on the indicator light body and gently pull to release from control panel.
4. Reverse procedure to reinstall indicator light.

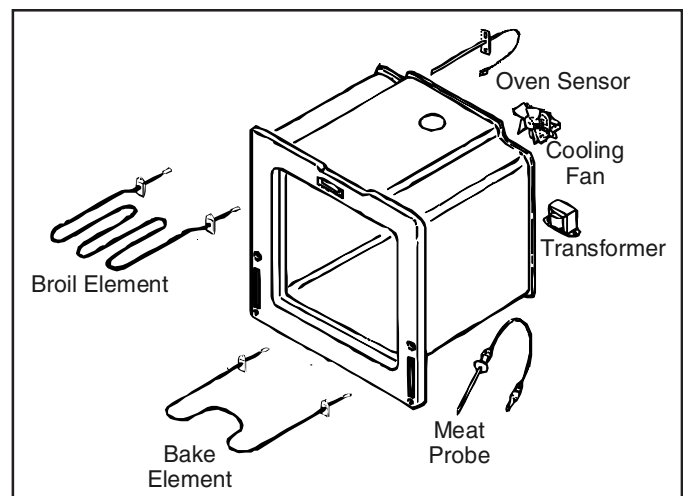

Disassembly Procedures



CAUTION

To avoid risk of electrical shock, personal injury or death; disconnect power to unit before servicing.

Meat Probe Receptacle (Select Models)

1. Turn power off.
2. Remove range from installation position, see "Removing and Replacing Range" procedure.
3. Remove main top, see "Main Top" procedure for removal.
4. Remove nut securing meat probe receptacle to cavity.
5. Reverse procedure to reinstall meat probe receptacle.

Back Panel

1. Remove power from unit.
2. Remove range from installation position, see "Removing and Replacing Range" procedure.
3. Remove screws securing upper back panel to unit.
4. Remove screws securing outside edges of the back panel to unit chassis.
5. Reverse procedure to reinstall back panel.

Cooling Fan

1. Remove power from unit.
2. Remove range from installation position, see "Removing and Replacing Range" procedure.
3. Remove back panel, see "Back Panel" procedure.
4. Label and disconnect wire terminals from cooling fan.
5. Remove screws securing fan to range chassis.
6. Reverse procedure to reinstall cooling fan.

Transformer

1. Remove power from unit.
2. Remove range from installation position, see "Removing and Replacing Range" procedure.
3. Remove back panel, see "Back Panel" procedure.
4. Label and disconnect wire terminals from cooling fan.
5. Remove screws securing fan to range chassis.
6. Reverse procedure to reinstall cooling fan.

Bake Element

1. Remove power from unit.
2. Open oven door and remove rack(s).
3. Remove screws securing bake element to rear of cavity wall.
4. Pull element forward to allow disconnection of terminals on each element leg.
5. Reverse procedure to reinstall bake element.

Broil Element

1. Remove power from unit.
2. Open oven door and remove racks.
3. Remove screws securing broil element to top and rear of oven cavity.
4. Pull broil element forward to allow disconnection of terminals on each element leg.
5. Reverse procedure to reinstall broil element.

Downdraft Blower Motor (Select Models)

1. Remove power from unit.
2. Remove bottom access panel, see "Bottom Access Panel" procedure.
3. Disconnect ducting to allow for downdraft blower motor removal.
4. Label and disconnect electrical connections.
5. Remove screws securing motor assembly.
6. Reverse procedure to reinstall downdraft blower motor (select models).

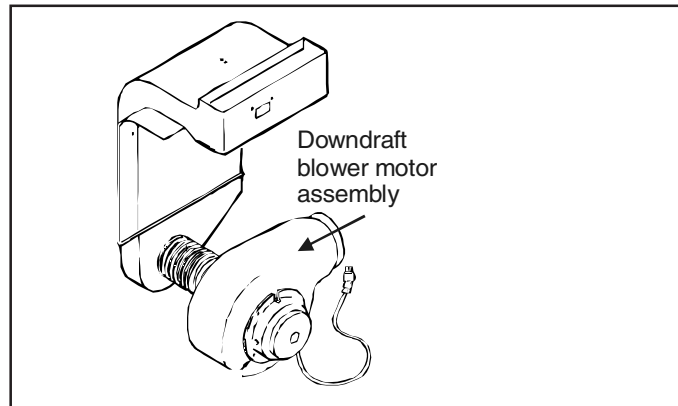

Oven Sensor

1. Remove power from unit.
2. Open oven door and remove screws securing sensor to oven cavity.

NOTE: Gently pull wiring through cavity wall.

3. Disconnect oven sensor at the connector terminal and remove.
4. Reverse procedure to reinstall sensor.

NOTE: Verify sensor wires are pushed through the insulation.

Front Side Trim

1. Remove power from unit.
2. Slide unit out far enough to access side trim.
3. Remove screws securing front side trim piece(s) to oven chassis (left and right trim pieces).
4. Gently grasp trim piece with both hands, pull forward and roll trim piece off retainer clips.
5. Reverse procedure to reinstall front side trim piece(s).

Oven Light Bulb/Oven Light Socket

NOTE: Requires removal of unit to replace oven light socket.

The light automatically comes on when the door is opened. The light will not operate during a clean cycle.

Disassembly Procedures



CAUTION

To avoid risk of electrical shock, personal injury or death; disconnect power to unit before servicing.

1. Remove power from unit.
2. Open oven door and locate oven light.
3. Grasp lens cover and pull outward on one side to gain access to bulb.
4. Carefully remove old bulb, by lifting bulb straight out of ceramic base.

NOTE: To avoid damaging the new bulb and decreasing life of the bulb, do not touch new bulb with bare hands or fingers.

Hold with a cloth or paper towel.

NOTE: Proceed with the following steps for oven light socket removal.

5. Remove unit from installation position, see "Removing and Replacing Range" procedure.
6. Disconnect or unplug the power cord leading from unit to fuse box or junction box depending on unit.
7. Carefully displace fiberglass insulation away from rear of light socket.
8. Release metal tabs on light socket and push socket assembly away from the oven cavity.
9. Label and disconnect wires from light socket.
10. Reverse procedure to reinstall light socket.
Reposition insulation around lamp socket.

NOTE: Reposition fiberglass insulation around light socket to eliminate the possibility of any heat related problems.

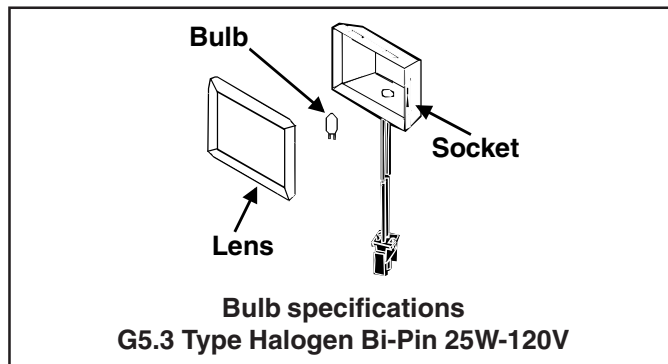

Oven Light Switch

1. Remove power from unit.
2. Remove control panel, see "Control Panel" procedure.
3. Remove screws securing oven light switch to front of oven chassis.
3. Reverse procedure to reinstall oven light switch.

Convection Fan

1. Remove power from unit.
2. Remove screws securing convection motor cover to oven chassis (screws at 12, 4 & 8 o'clock positions).
3. Remove screws securing convection motor to chassis.
4. Gently slide convection motor into oven cavity.

5. Label and disconnect electrical connection.
6. Replace and reverse procedure to reinstall motor.

Oven Vent/Smoke Eliminator

1. Remove power from unit.
2. Locate tabs on bottom of smoke eliminator and turn counterclockwise to release locking ears.
3. Gently pull smoke eliminator down and align locking ears with notches in oven cavity to remove.
4. Reverse procedure to reinstall smoke eliminator.

Hi-Limit Thermostat

1. Remove maintop assembly, see "Maintop Assembly" procedure.
2. Remove screws securing hi-limit thermostat to oven chassis.
3. Reverse procedure to reinstall hi-limit thermostat.

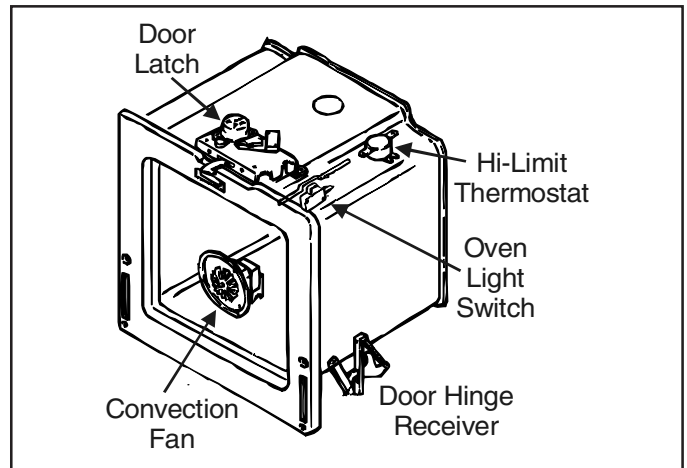

Oven Door Latch

1. Remove control panel, see "Control Panel" procedure.
2. Remove screws securing door latch to the front of the oven cavity outer shell.
3. Slide oven door latch assembly forward to diagnose.
4. Label and disconnect wire terminals from latch assembly.
5. Reverse procedure to reinstall door latch assembly.

Disassembly Procedures



CAUTION

To avoid risk of electrical shock, personal injury or death; disconnect power to unit before servicing.

Oven Door Removal



WARNING

To avoid risk of personal injury or property damage, do not lift oven door by the handle.

1. Open oven door and grasp door on both sides.
2. Lift up and off the hinge receivers.
3. Reverse procedure to reinstall oven door.

Oven Door Hinge

1. Remove power from unit.
2. Remove unit from installation position, see "Removing and Replacing Range" procedure.
3. Remove oven door, see "Oven Door Removal" procedure.
4. Remove front side trim, see "Front Side Trim" procedure.
5. Remove the top and bottom screws securing hinge receiver to the front frame.
6. Remove hinge receiver from oven chassis.
7. Reverse procedure to reinstall oven door hinge.

Door Disassembly

1. Remove oven door, see "Oven Door Removal" procedure.

2. Place door on a protected surface.
3. Remove screws securing bottom trim to oven door.
4. Slide outer oven door glass and trim towards the bottom of the oven door and remove.
5. Detach right and left trim pieces for outer door glass.

NOTE: Proceed with the following steps for door handle and inner door disassembly.

6. Remove screws securing top door handle trim to oven door chassis.
7. Remove screws securing door handle brackets to inner door panel.
8. Lift upward on the lower side of the door handle to release side alignment screws and rotate towards the top of the oven door to release and remove.
9. Remove screws securing door handle to door handle brackets.

NOTE: Proceed with the following steps for inner door disassembly.

10. Remove screws securing lower door glass retainer to door baffle and remove.
11. Slide inner door glass downward to release from upper door glass retainers and remove.
12. Remove screws securing door baffle to door lining and remove.
13. Remove insulation from oven door.
14. Lift inner glass and glass frame from oven door.
15. Reverse procedure to reassemble oven door.

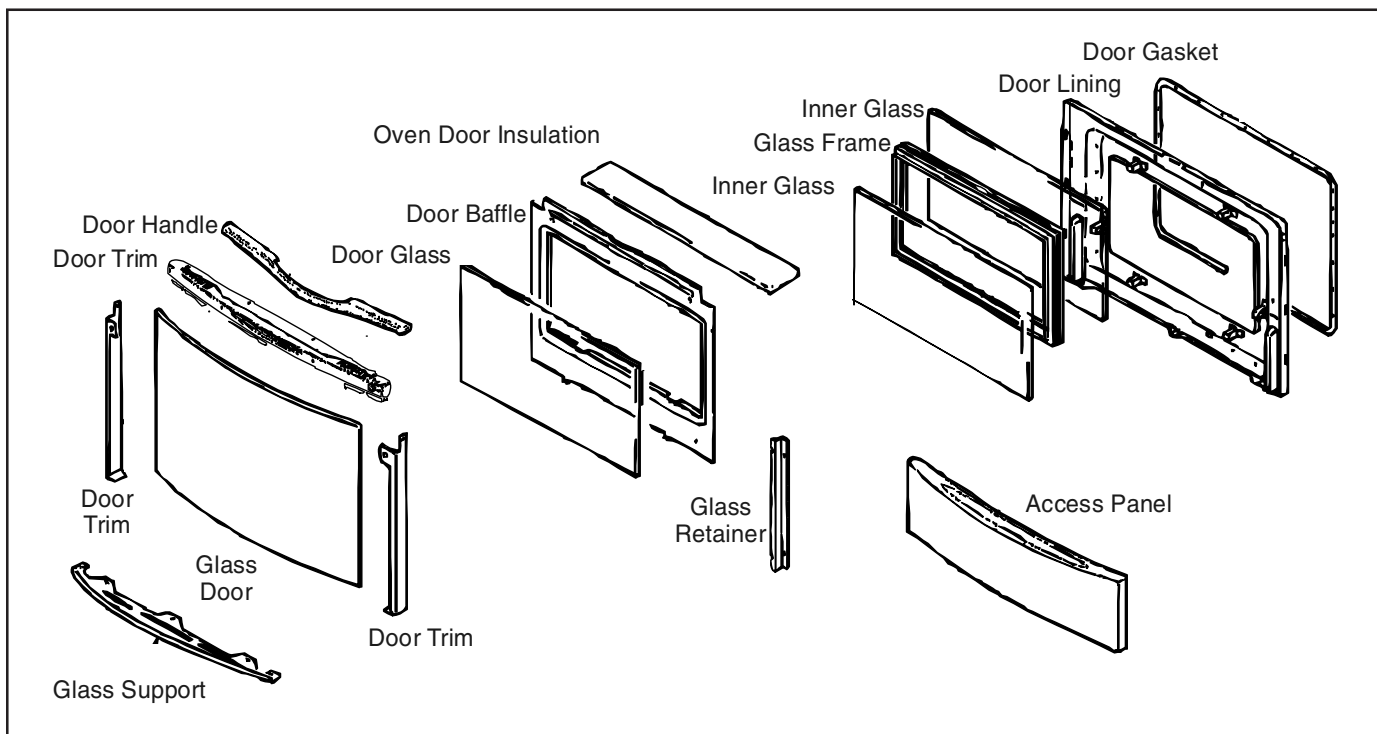

Appendix A

Installation Instructions (Model JDS8850A**)

INSTALLATION DRAWINGS

IMPORTANT

PLEASE KEEP FOR THE USE OF THE LOCAL ELECTRICAL INSPECTOR.

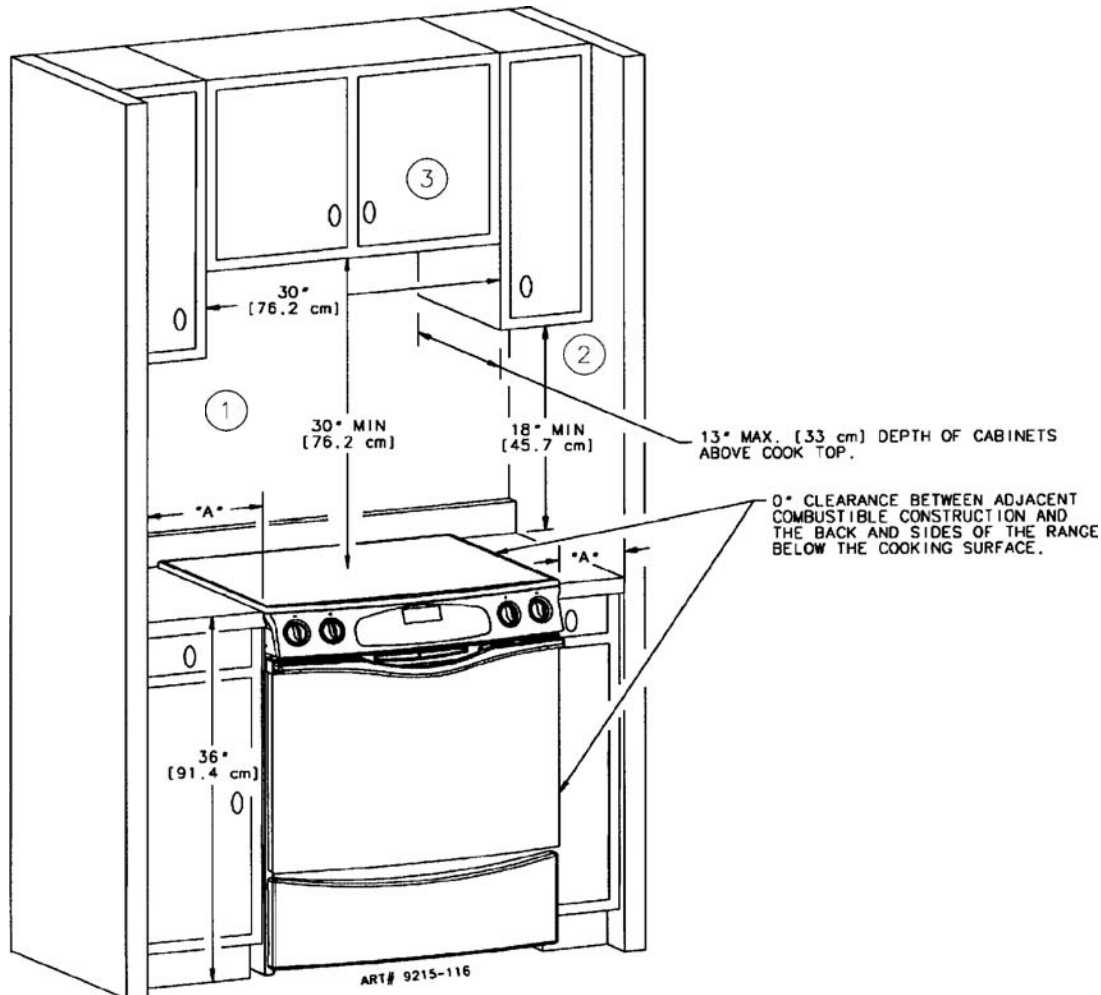

FIGURE 1

NOTE: Figure may not be representative of actual unit.

The 30 inches (76.2 cm) minimum clearance between the top of the cooking surface and the bottom of an unprotected wood or metal cabinet can be reduced to 24 inches (61 cm) minimum when bottom of wood or metal cabinet is protected by not less than 1/4-inch (6.4 mm) thick flame-retardant millboard covered with not less than No. 28 MSG sheet steel, 0.015-inch (0.381 mm) thick stainless steel, 0.024-inch (0.610 mm) thick aluminum, or 0.020-inch (0.508 mm) thick copper.

To eliminate the risk of burns or fire by reaching over heated surface units, cabinet storage space located above the surface units should be avoided. If cabinet storage is to be provided, the risk can be reduced by

installing a range hood that projects horizontally a minimum of 5 inches (13 cm) beyond the bottom of the cabinets.

FIGURE 1

- 1 ... COMBUSTIBLE BACK WALL.
- 2 ... COMBUSTIBLE SIDE WALL.
- 3 ... COMBUSTIBLE WALL CABINET.

DIMENSION "A" IS TO BE A MINIMUM OF 3 INCHES (7.5 CM).

A SLIDE-IN RANGE, IF EQUIPPED WITH OPTIONAL BACKGUARD KIT, MAY BE INSTALLED ZERO INCHES FROM COMBUSTIBLE WALL 1 (SEE FIGURE 1).

Installation Instructions (Model JDS8850A**)

* WHEN REPLACING AN EXISTING UNIT, A MAXIMUM CUT DEPTH OF 23 1/2" (59.7 cm) IS ACCEPTABLE.

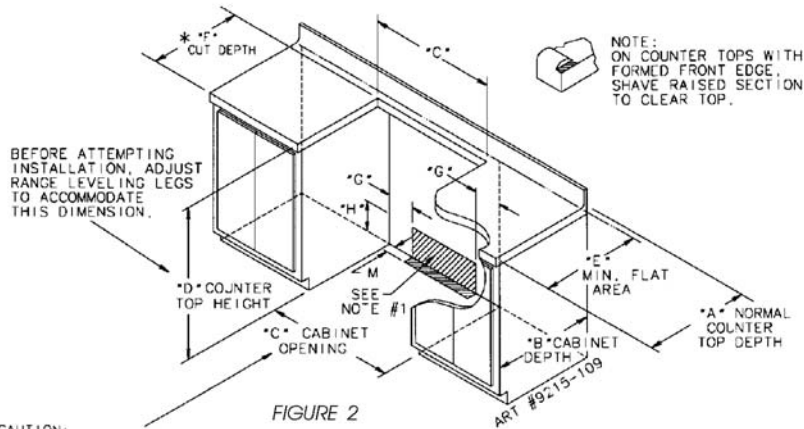

FIGURE 2

CAUTION:
SOME WHITE EUROPEAN STYLE CABINETS ARE EQUIPPED WITH DELICATE WHITE VINYL DRAWER AND DOOR FRONTS. THE VINYL MAY NOT BE DESIGNED TO WITHSTAND THE HEAT PRODUCED BY THE NORMAL SAFE OPERATION OF A SELF-CLEANING RANGE. DISCOLORATION OR DELAMINATION MAY OCCUR. TO AVOID POSSIBLE DAMAGE, WE RECOMMEND INCREASING THE 30" (76.2 cm) CABINET OPENING TO 31 1/4" (79.4 cm) MINIMUM AND USING A HEAT SHIELD KIT (CABKIT V), WHICH MAY BE ORDERED SEPARATELY. THE COUNTERTOP CUT-OUT MUST REMAIN 30" (76.2 cm).

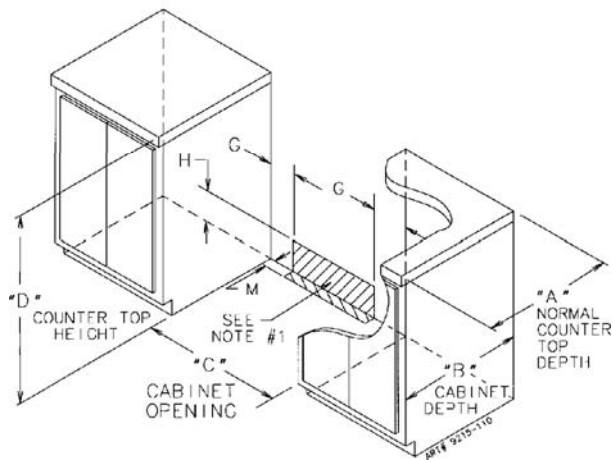

FIGURE 3

NOTES:

1. Provide for either a 3-wire or 4-wire 120/208, 120/240 volt outlet per applicable cord in shaded area shown. Refer to installation instructions for proper positioning of outlet. This is also the recommended gas line location.
2. Dimension K (figure 4, page 4) is from the wall to the side edge of the oven door. It does not include the curvature of the glass or the depth of the handle.
3. Dimension L (figure 4, page 4) is with the leveler legs adjusted all the way in. This may vary slightly upon leveling leg adjustment.
4. Do not use grout, epoxy, etc., to install this unit. Installation must allow for removal of this appliance from the installed location for purposes of servicing.

IMPORTANT: Because of continuing product improvements, Maytag reserves the right to change specifications without notice. Dimensional specifications are provided for planning purposes only. For complete details see installation instructions that accompany each product before selecting cabinetry, making cutouts or beginning installation.

Installation Instructions (Model JDS8850A**)

WARNING

THIS PRODUCT SHOULD NOT BE INSTALLED BELOW A VENTILATION TYPE HOOD SYSTEM THAT DIRECTS AIR IN A DOWNWARD DIRECTION.

(SEE FIGURE)

THESE SYSTEMS MAY CAUSE IGNITION AND COMBUSTION PROBLEMS WITH THE GAS BURNERS RESULTING IN PERSONAL INJURY AND MAY AFFECT THE COOKING PERFORMANCE OF THE UNIT.

NOTE: THE FIGURE MAY NOT ACCURATELY REPRESENT YOUR RANGE OR COOKTOP; HOWEVER, THIS WARNING APPLIES TO ALL GAS COOKING PRODUCTS.



ANTI-TIP DEVICE INSTALLATION

INSTRUCTIONS

WARNING: A risk of range tip-over exists if the appliance is not installed in accordance with the provided installation instructions. The proper use of this device minimizes the risk of TIP-OVER. In using this device the consumer must still observe the safety precautions as stated in the USE and CARE MANUAL and avoid using the oven doors as a step stool.

Installation instructions are provided for wood and cement in either floor or wall. Any other type of construction may require special installation techniques as deemed necessary to provide adequate fastening of the ANTI-TIP bracket to the floor or wall. The bracket may be installed to engage the LEFT or RIGHT rear leveling foot.

NOTE: The bracket provided is designed for use with flush mount and non-flush mount outlet receptacles.

Install the bracket with the orientation hole in the longer leg against the wall as shown in figure 5.

STEP 1 - Locating The Anti-tip Bracket

(See Figure 5)

- Determine where either the right or left "EDGE" of the range will be located and mark the floor or wall.
- Place the BRACKET 15/16" (24mm) from the marked "EDGE" toward center of opening and against the back wall as shown in figure 5, with orientation hole against wall.
- Use the bracket as a template and mark the required holes, as shown in figure 5, for the type of construction you will be using.
- Anti-tip bracket may be secured to either floor or wall. See Step 2 on page 6 for bracket installation options.

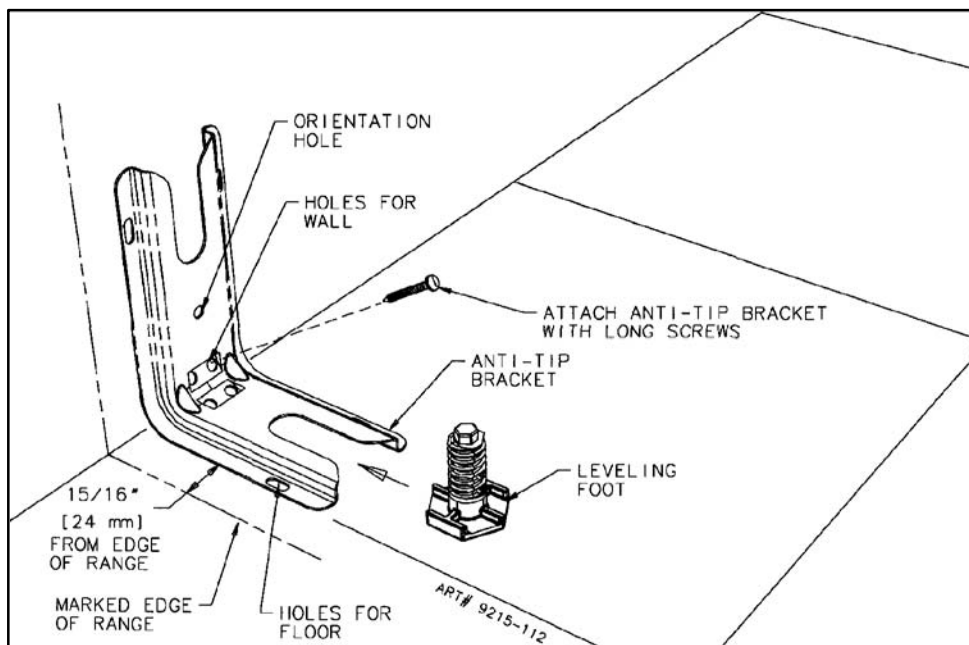

FIGURE 5

Installation Instructions (Model JDS8850A**)

STEP 2 - Anti-Tip Bracket Installation Options

A. Wood Construction:

1. Floor: Locate the center of the two holes identified in figure 5 as "HOLES FOR FLOOR." Drill a 1/8 (3 mm) pilot hole in the center of each hole (a nail or awl may be used if a drill is not available). Secure the ANTI-TIP bracket to the floor with the two screws provided. Proceed to STEP 3.
2. Wall: Locate the center of the two holes identified in figure 5 as "HOLES FOR WALL." Drill an angled 1/8 (3 mm) pilot hole in the center of each hole as shown in figure 6. (A nail or awl may be used if a drill is not available). Secure the ANTI-TIP bracket to the wall with the two screws provided as shown in figure 6. Proceed to STEP 3.

B. Cement or Concrete Construction:

1. Suitable screws for concrete construction can be obtained at the hardware store. Drill the required size hole for the hardware obtained into the concrete at the center of the holes identified in figure 5 as "HOLES FOR FLOOR". Secure the ANTI-TIP bracket to the floor. Proceed to STEP 3.

STEP 3 - Range Installation

- A. A Jenn-Air range may be installed by one person.
- B. Align the range to its designated location and slide it back into position. Note: A minimum clearance of 1/4 (6 mm) is required between the range and the leveling foot that will engage the ANTI-TIP bracket, see figure 6.
- C. All Jenn-Air ranges have a non lift-up top.
- D. For SAFETY CONSIDERATIONS as well as optimum performance adjust the range so that it is level. This may be checked by placing a spirit level or a large pan of water on the cooktop or the oven rack. If an adjustment is required pull the range forward, tip the range and rotate the leveling feet as required.
- E. To check the range for proper installation of the anti-tip bracket: Use a flashlight and look underneath the bottom of the range to see that one of the rear leveling feet is engaged in the bracket slot.
- F. Proceed with the remainder of the installation instructions provided with the range.

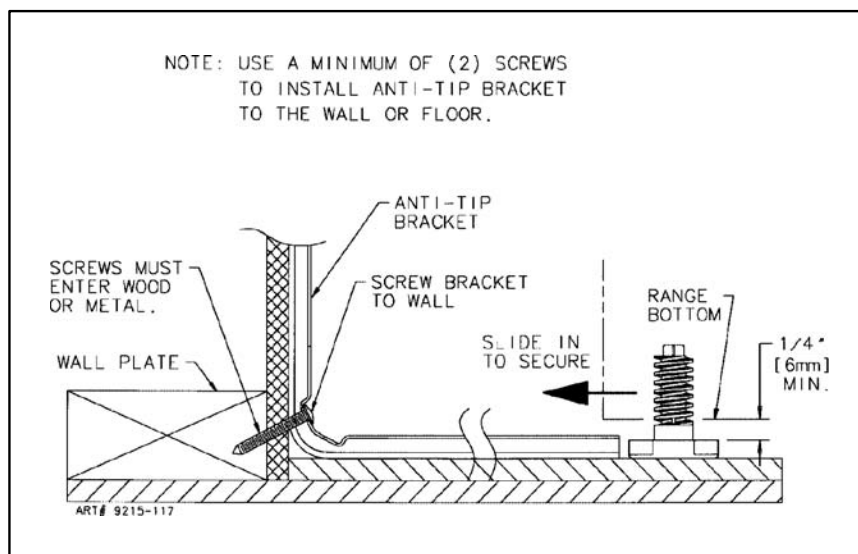

FIGURE 6

Installation Instructions (Model JDS8850A**)

CONNECTING THE RANGE TO ELECTRIC SUPPLY



WARNING

**DISCONNECT ELECTRICAL SUPPLY
BEFORE SERVICING THE APPLIANCE.**

ELECTRIC SUPPLY

The range must be installed in accordance with Local and National Electric Code (NEC) ANSI/NFPA No. 70-latest edition. See rating plate for total connected KW rating.

ELECTRIC SUPPLY (Canada)

The range must be installed in accordance with Local and Canadian Electric Code CSA STD.C22.1 latest edition. See rating plate for total connected KW rating.

OUTSIDE WIRING

Your local utility company will tell you whether the present electric service to your home is adequate. It may be necessary to increase the size of the wiring to the house and service switch to take care of the electrical load demanded by the range. The kilowatt rating for the range is specified on the rating plate located on the front of the range.

HOUSE WIRING

Most local Building Regulations and Codes require that all electrical wiring be done by licensed electricians. All wiring should conform to Local and National Electrical Codes. This range requires a single phase three wire 120/240 or a 120/208 volt, 60 Hz, AC circuit. Wiring codes require a separate circuit be run from the main entrance panel to the range and that it be equipped with separate disconnect switch and fuses, either in the main entrance panel or in a separate switch and fuse box. In some communities, a solid or flexible continuous armored conduit must be used from main entrance panel to the terminal box on the rear of the range. Others will permit the termination of the range circuit at a polarized three or four wire plug-in outlet placed at a convenient point near the back of the range. The range is then connected to this outlet through an approved range connector (pigtail) fastened securely to the terminal block with proper strain relief at the range and a three or four pronged plug at the opposite end.

User may experience occasional circuit tripping if Ground Fault Circuit Interrupter (GFCI) outlet or breaker is in use.

RANGE CONNECTIONS

Some models are shipped direct from the factory with service cords (pigtails) attached. There are no range connections necessary on these models. Just plug into the range outlet. On models not provided with a service cord, connection to the power supply is necessary. **REMEMBER** - only a 4-conductor cord is to be used on new branch-circuit installations (1996 NEC), mobile homes, recreational vehicles, or in an area where local codes prohibit grounding through the neutral conductor. Hence, 4-wire service **MUST** be provided for such installations. 3-wire service may be used when permitted by local code. **USE COPPER OR ALUMINUM CONDUCTORS.** Main terminal block is recognized for Copper or Aluminum conductors. If a flexible power cord is required, it is recommended a cord no longer than 4 ft. be used. Make connections as explained below and with reference to the appropriate illustration (see figures 8 and 9). After installation, insure tightness of all electrical connections and replace all covers.

Remove terminal block access cover from range back. (See figure 7).

RANGE CONNECTIONS (Canada)

This model was shipped direct from the factory with service cord (pigtail) attached. There are no range connections necessary. Just plug into the range outlet. See figure 2 on page 3 for outlet location.

NOTE: Cord replacement - **ONLY** a power supply cord rated at 240 volts minimum, 40 amperes or 50 amperes power supply cord that is marked for use with nominal 1 3/8 (34.93 mm) diameter connection opening, with closed loop terminals and marked for use with ranges shall be used.

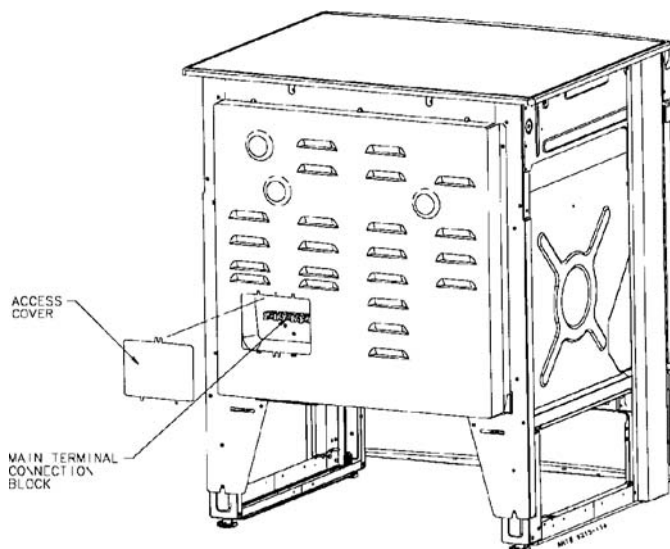

FIGURE 7

Installation Instructions (Model JDS8850A**)

FIGURE 8

3-Wire Service Cord or Conduit Installation

1. Insure that the copper ground strap **IS CONNECTED** between the middle post of the main terminal connection block and the range chassis.
2. If bare copper or aluminum wiring is used, attach adapter lugs as shown in figure 8. (See Bare Wire Connection). Torque specifications are shown below.
3. The middle wire of the service cord or ground lead of 3-wire conduit **MUST** connect to the neutral (middle) post of the main terminal block. The other two wires of the service cord or conduit connect to the outside posts of the main terminal connection block. Polarity is unimportant. (If using bare wire, attach wire to appropriate lug as shown. Torque specifications are shown below).
4. An appropriate strain relief for service cord or conduit **MUST** be attached to the conduit plate.

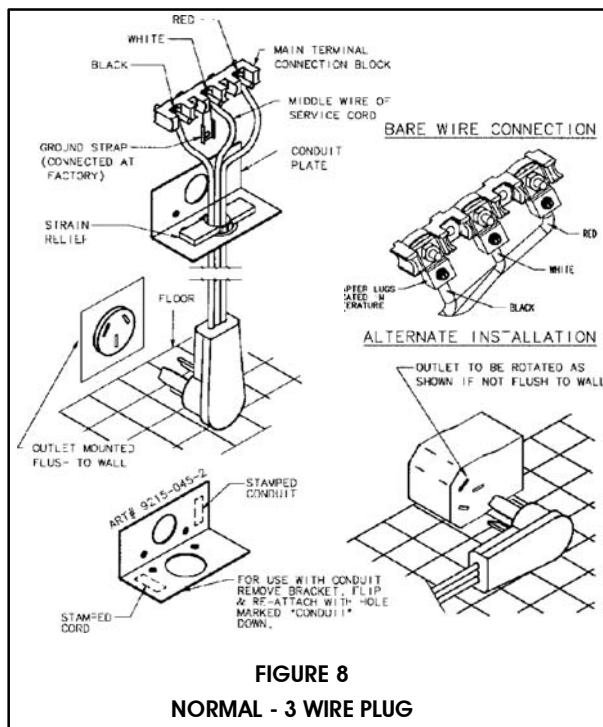

FIGURE 8
NORMAL - 3 WIRE PLUG

Conversion From 3-Wire To 4-Wire Service (Free-Standing or Slide-In Models Only With 3-Wire Service Cord Attached).

Disconnect range from power. Remove the access cover on back of range and remove the 3-wire service cord from the main terminal block. Follow instructions as outlined in figure 9 to connect the 4-wire service cord.

NOTE: Cord replacement - **ONLY** a power supply cord rated at 240 volts minimum, 40 amperes or 50 amperes power supply cord that is marked for use with nominal 1 3/8 (34.93 mm) diameter connection opening, with closed loop terminals and marked for use with ranges shall be used.

FIGURE 9

4-Wire Service Cord or Conduit Installation (Mobile Homes Or As Required By Codes)

1. The copper ground strap connected between the neutral (middle) post of the main terminal block and the chassis **MUST** be cut off as shown in figure 9. Save the green ground screw to attach the ground from the 4 wire cord. Only a 4 wire cord or conduit should be used.
2. If bare copper or aluminum wiring is used, attach adapter lugs as shown in figure 9. (See Bare Wire Connection). Torque specifications are shown below.
3. The ground wire from the service cord or conduit must connect to the range chassis using the green ground screw.
4. The white wire of the service cord or conduit must connect to the neutral (middle) post of the main terminal block. The other two wires of the service cord connect to the red and black posts of the main terminal block, respectively. (If using bare wire, attach wire to appropriate lug as shown. Torque specifications are shown below).
5. An appropriate strain relief for service cord or conduit **MUST** be attached to the conduit plate.

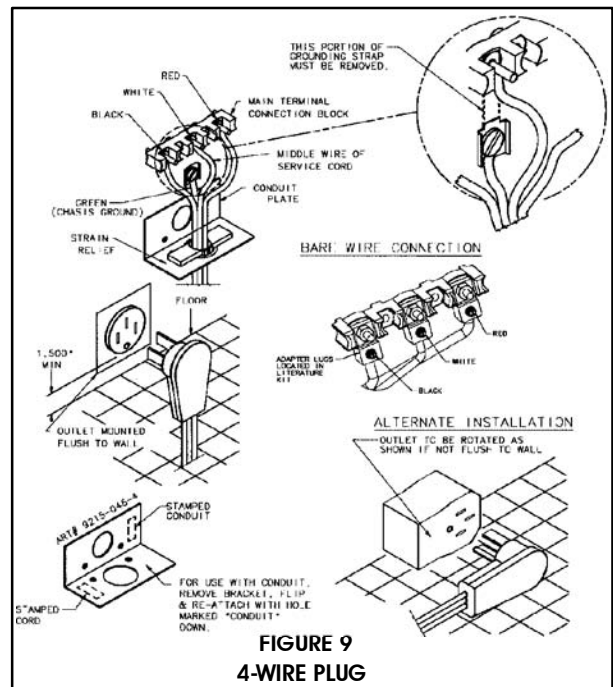

FIGURE 9
4-WIRE PLUG

Bare Wire Torque Specifications Lug attached to Terminal Block - 20 in-lb

Wire AWG	Torque
10 - 14	20 in-lb
8	25 in-lb
4 - 6	35 in-lb

Installation Instructions (Model JDS8850A**)

CONNECTING THE RANGE TO GAS SUPPLY

GAS SUPPLY

Installation of this range must conform with local codes or, in the absence of local codes, with the National Fuel Gas Code, ANSI Z223.1-latest edition.

In Canada the range must be installed in accordance with the current CGA Standard CAN/CGA-B149 - Installation Codes for Gas Burning Appliances and Equipment and/or local codes.

In The Commonwealth Of Massachusetts

This product must be installed by a licensed plumber or gas fitter when installed within the Commonwealth of Massachusetts.

A "T" handle type manual gas valve must be installed in the gas supply line to this appliance.

A flexible gas connector, when used, must not exceed a length of three (3) feet / 36 inches.

GAS SUPPLY CONNECTION: (See figure 7)

A QUALIFIED SERVICEMAN OR GAS APPLIANCE INSTALLER MUST MAKE THE GAS SUPPLY CONNECTION. Leak testing of the appliance shall be conducted by the installer according to the instructions given in section h.

NATURAL GAS SUPPLY LINE MUST HAVE A NATURAL GAS SERVICE REGULATOR. INLET PRESSURE TO THIS APPLIANCE SHOULD BE REDUCED TO A MAXIMUM OF 14 INCHES WATER COLUMN (0.5 POUNDS PER SQUARE INCH (PS.I.) LIQUEFIED PETROLEUM (L.P.) /PROPANE GAS SUPPLY LINE MUST HAVE A L.P. GAS PRESSURE REGULATOR. INLET PRESSURE TO THIS APPLIANCE SHOULD BE REDUCED TO A MAXIMUM OF 14 INCHES WATER COLUMN (0.5 PS.I.). INLET PRESSURES IN EXCESS OF 0.5 PS.I. CAN DAMAGE THE APPLIANCE PRESSURE REGULATOR AND OTHER GAS COMPONENTS IN THIS APPLIANCE AND CAN RESULT IN A GAS LEAK.

- a. A GAS CUTOFF VALVE SHOULD BE PUT IN AN ACCESSIBLE LOCATION IN THE SUPPLY LINE AHEAD OF THE RANGE, FOR TURNING ON AND TURNING OFF GAS SUPPLY. If range is to be connected to house piping with flexible or semi-rigid metal connectors for gas appliances, CONNECTOR NUTS MUST NOT BE CONNECTED DIRECTLY TO PIPE THREADS. THE CONNECTORS MUST BE INSTALLED WITH ADAPTORS PROVIDED WITH THE CONNECTOR.
- b. The house piping and/or range connector used to connect the range to the main gas supply must be clean, free of metal shavings, rust, dirt and liquids (oil or water). Dirt, etc. in the supply lines can work its way into the range manifold and in turn cause failure of the

gas valves or controls and clog burners and/or pilot orifices.

CAUTION: DO NOT LIFT OR MOVE RANGE BY DOOR HANDLES, OR BACKGUARD.

- c. Turn off all pilots and main gas valve of other gas appliances.
- d. Turn off main gas valve at meter.
- e. Before connecting range, apply pipe thread compound approved for LPG to all threads.
- f. Connect range to gas supply at appliance pressure regulator using adaptors supplied with flexible connector. Rigid pipe may also be used. See rating plate for type of gas range has been manufactured for.
- g. Turn on main gas valve at meter, and relight pilots at other gas appliances.

IMPORTANT

Apply a non-corrosive leak detection fluid to all joints and fittings in the gas connection between the supply line shut-off valve and the range. Include gas fittings and joints in the range if connections were disturbed during installation. Check for leaks! Bubbles appearing around fittings and connections will indicate a leak. If a leak appears, turn off supply line gas shut-off valve, tighten connections, turn on the supply line gas shut off valve, and retest for leaks.

CAUTION: NEVER CHECK FOR LEAKS WITH A FLAME.

WHEN LEAK CHECK IS COMPLETE, WIPE OFF ALL RESIDUE.



WARNING

Gas leaks may occur in your system and result in a dangerous situation. Gas leaks may not be detected by smell alone. Gas suppliers recommend you purchase and install an UL approved gas detector. Install and use in accordance with the manufacturer's instructions.

CHECKING PRESSURE OF HOUSE PIPING SYSTEM

1. The appliance and its individual shutoff valve must be disconnected from the gas supply piping system during any pressure testing of that system at test pressures in excess of 1/2 lbs./sq. in. (3.5 kPa) (13.8 in. water column).
2. The appliance must be isolated from the gas supply piping system by closing its individual manual shutoff valve during any pressure testing of the gas supply piping system at test pressures equal to or less than 1/2 lbs./sq. in. (3.5 kPa) (13.8 in. water column).

Installation Instructions (Model JDS9860A**)

* WHEN REPLACING AN EXISTING UNIT, A MAXIMUM CUT DEPTH OF 23 1/2" (59.7 cm) IS ACCEPTABLE.

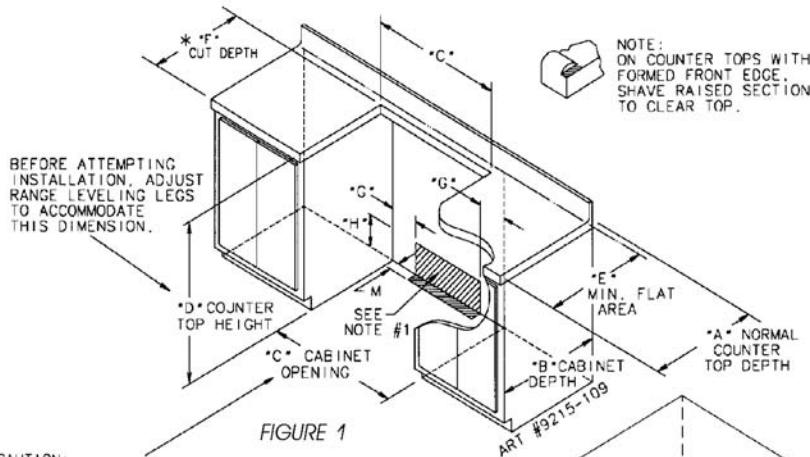

FIGURE 1

CAUTION:
SOME WHITE EUROPEAN STYLE CABINETS ARE EQUIPPED WITH DELICATE WHITE VINYL DRAWER AND DOOR FRONTS. THE VINYL MAY NOT BE DESIGNED TO WITHSTAND THE HEAT PRODUCED BY THE NORMAL SAFE OPERATION OF A SELF-CLEANING RANGE. DISCOLORATION OR DELAMINATION MAY OCCUR. TO AVOID POSSIBLE DAMAGE, WE RECOMMEND INCREASING THE 30" (76.2 cm) CABINET OPENING TO 31 1/4" (79.4 cm) MINIMUM AND USING A HEAT SHIELD KIT (CABKIT V), WHICH MAY BE ORDERED SEPARATELY. THE COUNTERTOP CUT-OUT MUST REMAIN 30" (76.2 cm).

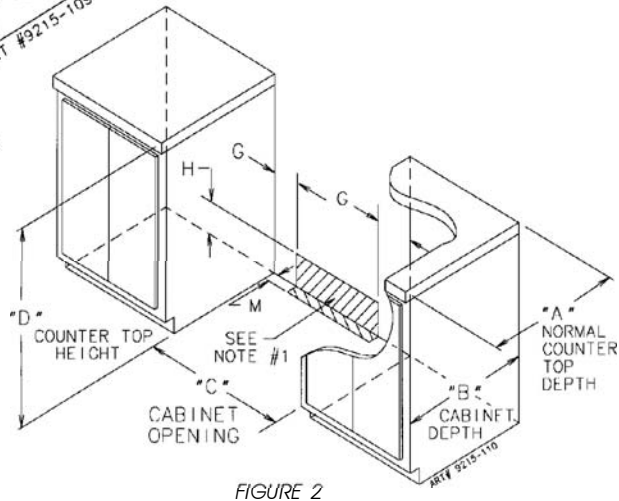

FIGURE 2

NOTES:

1. Provide for either a 3-wire or 4-wire 120/208, 120/240 volt outlet per applicable cord in shaded area shown. Refer to installation instructions for proper positioning of outlet. This is also the recommended gas line location.
2. Dimension K (figure 3, page 3) is from the wall to the side edge of the oven door. It does not include the curvature of the glass or the depth of the handle.
3. Dimension L (figure 3, page 3) is with the leveler legs adjusted all the way in. This may vary slightly upon leveling leg adjustment.
4. Do not use grout, epoxy, etc., to install this unit. Installation must allow for removal of this appliance from the installed location for purposes of servicing.

Installation Instructions (Model JDS9860A**)

ANTI-TIP DEVICE INSTALLATION

INSTRUCTIONS

NOTE: A risk of range tip over exists if the appliance is not installed in accordance with the installation instructions provided. The proper use of this device minimizes the risk of TIP-OVER. In using this device the consumer must still observe the safety precautions as stated in the USE and CARE MANUAL and avoid using the oven door and/or lower drawer as a step stool.

Installation instructions are provided for wood and cement in either floor or wall. Any other type of construction may require special installation techniques as deemed necessary to provide adequate fastening of the ANTI-TIP bracket to the floor or wall.

STEP 1 - Locating The Bracket (see figure 5)

- Determine where either the right or left rear "edge" of the range will be located and mark the floor or wall.
- Place the BRACKET 15/16" from the marked "EDGE" toward center of opening and against the back wall as shown in figure 5.
- Use the bracket as a template and mark the required holes, as shown in figure 5 for the type of construction you will be using.

STEP 2 - Anti-Tip Bracket Installation

- Wood Construction:**
 - Floor: Locate the center of the two holes identified in figure 5 as "HOLES FOR FLOOR". Drill a 1/8" pilot hole in the center of each hole (a nail or awl may be used if a drill is not available). Secure the ANTI-TIP bracket to the floor with the two screws provided. Proceed to STEP 3.
 - Wall: Locate the center of the two holes identified in figure 5 as "HOLES FOR WALL". Drill an angled

1/8" pilot hole in the center of each hole as shown in figure 6. (A nail or awl may be used if a drill is not available). Secure the ANTI-TIP bracket to the wall with the two screws provided as shown in figure 6. Proceed to STEP 3.

B. Cement or Concrete Construction:

- Suitable screws for concrete construction can be obtained at a hardware store. Drill the required size hole for the screws obtained into the concrete at the center of the holes identified in figure 5 as "HOLES FOR FLOOR". Secure the ANTI-TIP bracket to the floor. Proceed to STEP 3.

STEP 3 - Range Installation

- Align the range to its designated location and slide it back into position. Make sure that the leveling foot is fully inserted into and secured by the ANTI-TIP bracket. Note: A minimum clearance of 1/4" is required between the range and the leveling foot that will engage the ANTI-TIP bracket, see figure 6.
- For safety considerations as well as optimum performance adjust the range so that it is level. This may be checked by placing a spirit level or a large pan of water on the cooktop or the oven rack. Jenn-Air ranges require total removal from cabinet before an adjustment can be made.
- To check the range for proper installation of the anti-tip bracket: Use a flashlight and look underneath the bottom of the range to see that one of the rear leveling legs is engaged in the bracket slot.
- Proceed with the remainder of the installation instructions.

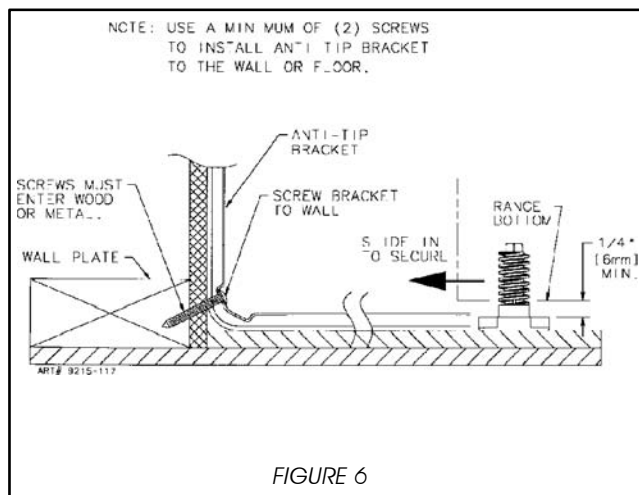
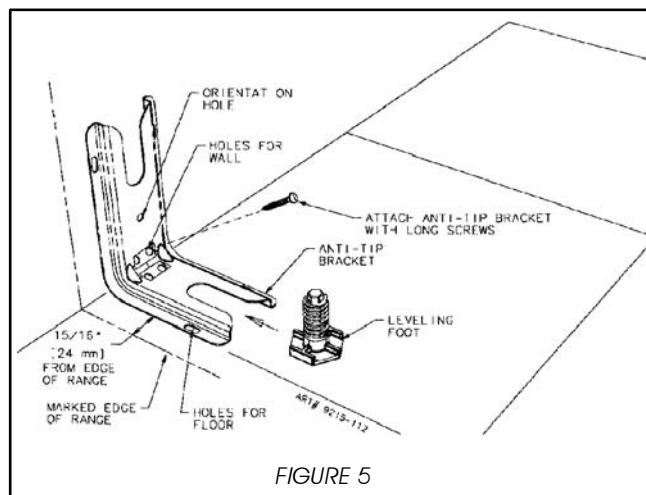

Installation Instructions (Model JDS9860A**)

CONNECTING THE RANGE

ELECTRIC SUPPLY

The range must be installed in accordance with Local and National Electric Code (NEC) ANSI/NFPA No. 70-latest edition. See rating plate for total connected KW rating.

ELECTRIC SUPPLY (Canada)

The range must be installed in accordance with Local and Canadian Electric Code CSA STD.C22.1 latest edition. See rating plate for total connected KW rating.

OUTSIDE WIRING

Your local utility company will tell you whether the present electric service to your home is adequate. It may be necessary to increase the size of the wiring to the house and service switch to take care of the electrical load demanded by the range. The kilowatt rating for the range is specified on the rating plate located on the front of the range.

HOUSE WIRING

Most local Building Regulations and Codes require that all electrical wiring be done by licensed electricians. All wiring should conform to Local and National Electrical Codes. This range requires a single phase three wire 120/240 or a 120/208 volt, 60 Hz, AC circuit. Wiring codes require a separate circuit be run from the main entrance panel to the range and that it be equipped with separate disconnect switch and fuses, either in the main entrance panel or in a separate switch and fuse box. In some communities, a solid or flexible continuous armored conduit must be used from main entrance panel to the terminal box on the rear of the range. Others will permit the termination of the range circuit at a polarized three or four wire plug-in outlet placed at a convenient point near the back of the range. The range is then connected to this outlet through an approved range connector (pigtail) fastened securely to the terminal block with proper strain relief at the range and a three or four pronged plug at the opposite end.

User may experience occasional circuit tripping if Ground Fault Circuit Interrupter (GFCI) outlet or breaker is in use.

RANGE CONNECTIONS

Some models are shipped direct from the factory with service cords (pigtails) attached. There are no range connections necessary on these models. Just plug into the range outlet. On models not provided with a service cord, connection to the power supply is necessary. **REMEMBER** - only a 4-conductor cord is to be used on new branch-circuit installations (1996 NEC), mobile homes, recreational vehicles, or in an area where local codes prohibit grounding through the neutral conductor. Hence, 4-wire service **MUST** be provided for such installations. 3-wire service may be used when permitted by local code. **USE COPPER OR ALUMINUM CONDUCTORS.** Main terminal block is recognized for Copper or Aluminum conductors. If a flexible power cord is required, it is recommended a cord no longer than 4 ft. be used. Make connections as explained below and with reference to the appropriate illustration (see figures 8 and 9). After installation, insure tightness of all electrical connections and replace all covers.

Remove terminal block access cover from range back. (See figure 7).

RANGE CONNECTIONS (Canada)

This model was shipped direct from the factory with service cord (pigtail) attached. There are no range connections necessary. Just plug into the range outlet. See figure 2 on page 3 for outlet location.

NOTE: Cord replacement - **ONLY** a power supply cord rated at 240 volts minimum, 40 amperes or 50 amperes power supply cord that is marked for use with nominal 1 3/8 (34.93 mm) diameter connection opening, with closed loop terminals and marked for use with ranges shall be used.

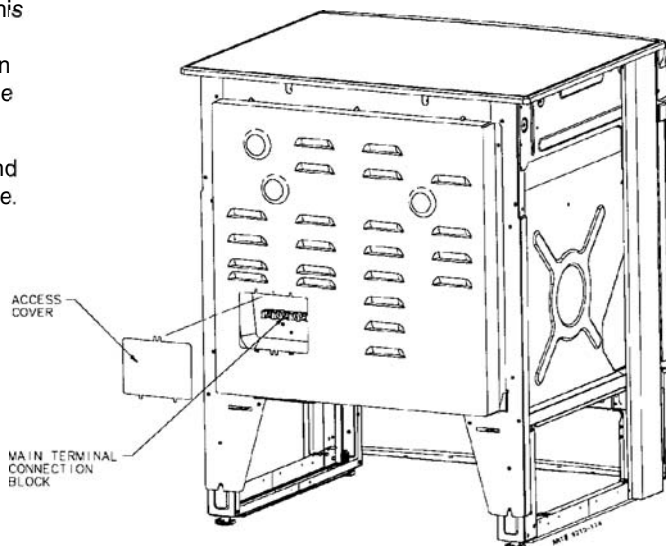

FIGURE 7

Installation Instructions (Model JDS9860A**)

3-WIRE SERVICE CORD OR CONDUIT INSTALLATION

1. Insure that the copper ground strap **IS CONNECTED** between the middle post of the main terminal connection block and the range chassis.
2. The middle wire of the service cord or ground lead of 3-wire conduit **MUST** connect to the neutral (middle) post of the main terminal block. The other two wires of the service cord or conduit connect to the outside posts of the main terminal connection block. Polarity is unimportant.
3. A appropriate strain relief for service cord or conduit must be attached to the conduit plate.

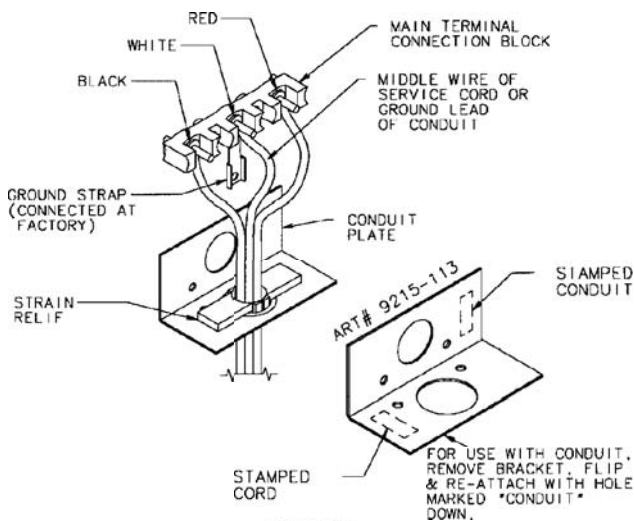

FIGURE 8
ACCEPTABLE 3-WIRE PLUG INSTALLATION

4-WIRE SERVICE CORD OR CONDUIT INSTALLATION

(MOBILE HOMES OR AS REQUIRED BY CODES)

1. The copper ground strap connected between the neutral (middle) post of the main terminal block and the chassis **MUST** be cut off as shown in figure 9. Save the green ground screw to attach the ground from the 4 wire cord. Only a 4 wire cord or conduit should be used.
2. The ground wire from the service cord or conduit must connect to the range chassis using the green ground screw.
3. The white wire of the service cord or conduit must connect to the neutral (middle) post of the main terminal block. The other two wires of the service cord or conduit connect to the red and black posts of the main terminal block, respectively.
4. An appropriate strain relief for service cord or conduit must be attached to the conduit plate.

CONVERSION FROM 3-WIRE TO 4-WIRE SERVICE

(Model With 3-Wire Service Cord Attached)

Disconnect range from power. Remove the access cover on back of range and remove the 3-wire service cord from the main terminal block. Follow instructions as outlined in figure 9 to connect the 4-wire service cord.

NOTE: Cord replacement - **ONLY** a power supply cord rated at 240 volts minimum, 40 amperes or 50 amperes power supply cord that is marked for use with nominal 1 3/8 (34.93 mm) diameter connection opening, with closed loop terminals and marked for use with ranges shall be used.

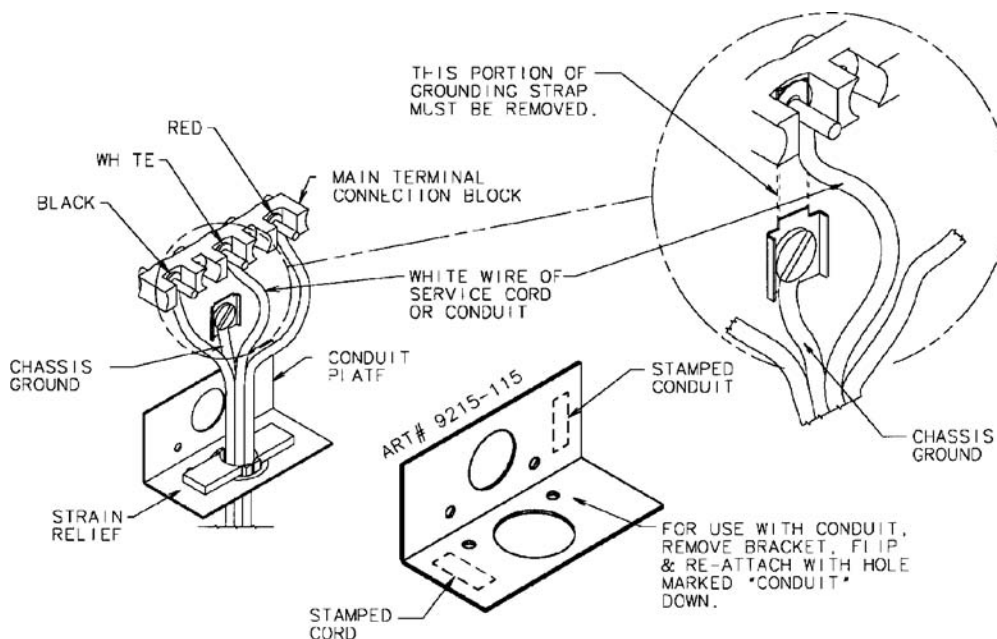

FIGURE 9
ACCEPTABLE 4-WIRE PLUG INSTALLATION

Installation Instructions (Model JDS9860A**)

DOWNDRAFT INSTALLATION INSTRUCTIONS

S Determine where you will be locating the electrical outlet. It must be in the floor or on the wall within the area shown in figure 2 or 3.

S Determine how you will be venting your downdraft blower. You may vent through the rear wall, the floor, or the sides. When locating the downdraft vent opening make sure it will not interfere with your electrical outlet.

- a. **Through the rear wall.** (See figure 10) Mark the centerline of the cabinet opening on the rear wall. The 6 1/4" vent opening must be located on a centerline 8 3/8" above the floor and within 3 1/4" to the right (when facing the cabinet opening) of the centerline of the cabinet opening as shown in figure 10.

Cut a 6 1/4" diameter hole on the marked centerline making sure to miss any wall studs. Install the blower as shown in figure 12.

- b. **Through the floor.** (See figure 11) Making sure to miss any floor joists cut a 6 1/4" diameter hole in the shaded area as shown in figure 11. Install the blower as shown in figure 12.

NOTE: If the floor is a concrete slab, see the enclosed ducting instructions.

- c. **Through the Left or Right side cabinet.** (See figure 13).

1. Additional materials required:

1 pc 5" diameter x 19" long (12.7 cm x 48.26 cm).

Flex duct (P/N 702935).

1 pc 6" (15.25 cm) 90° elbow.

2 Hose Clamps (P/N 702331).

1 pc 5" to 3 1/4" x 10" (12.7 cm to 8.26 cm x 25.4 cm) Transition.

2 pcs Wood spacers (right side vent only)
1 1/2" thick x 9" long (3.81 cm x 22.68 cm).

(See your local dealer for these accessories).

2. Cut hole in either the left or right side of the cabinet wall as shown in figure 13.

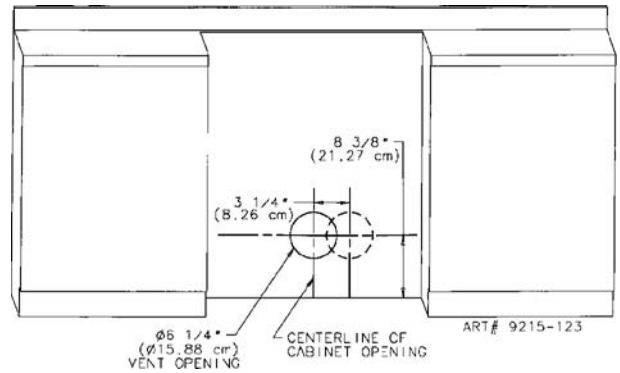

Figure 10

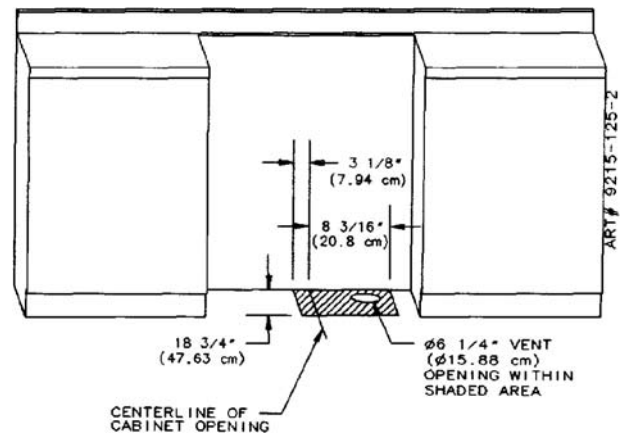

Figure 11

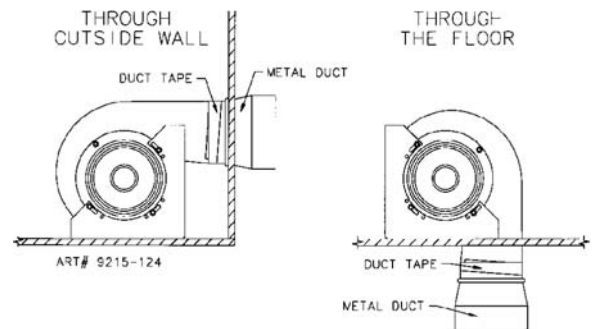

Figure 12

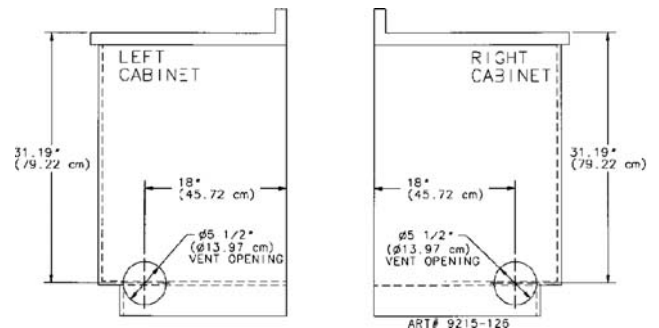

Figure 13

Installation Instructions (Model JDS9860A**)

3. Make cutout in the cabinet floor of either the right or left side cabinet as shown in figures 14 or 15.
4. Relocate the mounting brackets on the blower housing as shown in figure 17.

NOTE: The mounting brackets shown in figure 16 are as assembled at the factory for floor or rear wall venting.

a. Right side venting (figure 17).

1. Remove nuts from studs 1, 2 and 3 on the motor side.
2. Remove bracket and reattach with studs 1 and 2 inserted in holes A and C and replace 3 nuts.
3. Remove nuts from studs 5, 6 and 7 on air inlet side.
4. Remove bracket and reattach with studs 5 and 6 inserted in holes D and B and replace 3 nuts.

b. Left side venting (figure 17).

1. Remove nuts from studs 1, 2, 3 and 4 on motor side.
 2. Remove bracket.
 3. Rotate motor and cover assembly 180 degrees.
 4. Reattach bracket with studs 4 and 1 inserted in holes A and C and replace all 4 nuts.
 5. Remove nuts from studs 5, 6, 7 and 8 on inlet side.
 6. Remove bracket and reattach with studs 8 and 5 inserted in holes D and B and replace all 4 nuts.
5. Attach the blower housing to the floor with the outlet towards the direction of the venting and the inlet towards the front of the cabinets. In addition, for left side venting, a spacer of approximately 1-1/2" thick x 9" long (3.81 cm x 22.86 cm) is required under the mounting bracket flanges of the blower assembly (see figure 17).
 6. Remove the inside wire and outside string from the first 1-1/2" (3.81 cm) of one end of the 5" (12.7 cm) flex duct (P/N 702935). Stretch this end of the flex duct over the end of the 5" x 3-1/4" x 10" (12.7 cm x 25.4 cm) transition and secure with hose clamp (P/N 702331).
 7. When the range is placed in position, feed the open end of the 5" (12.7 cm) flex duct through the hole in the cabinet side wall and attach to the outlet of the blower housing with hose clamp (P/N 702331). The transition should then be attached to the 3-1/4" x 10" (12.7 cm x 25.4 cm) ducting in the cabinet toe space through the cabinet floor cutout.

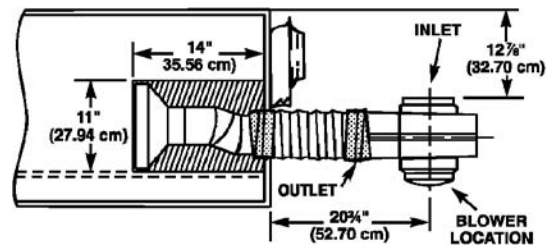

Figure 14
Left Cabinet (Top View)

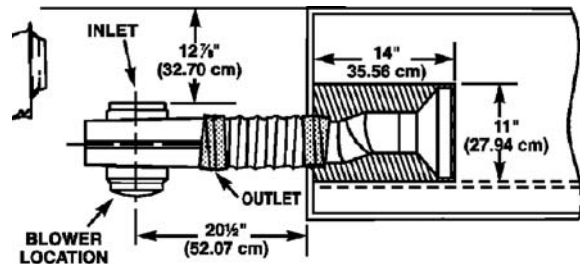

Figure 15
Right Cabinet (Top View)

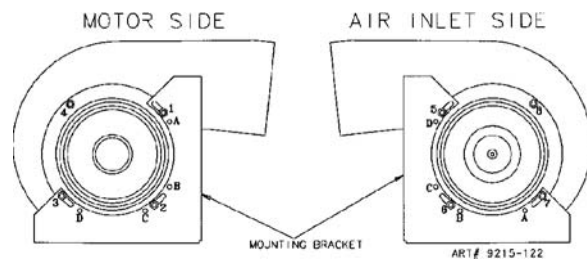

Figure 16
Blower Assembly

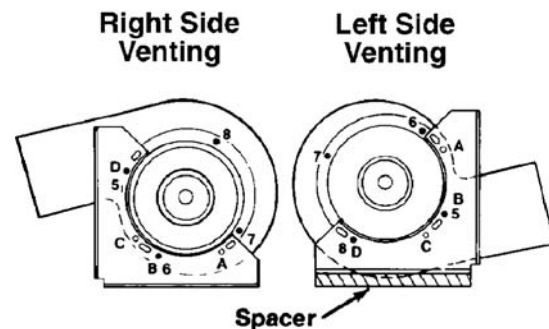

Figure 17
View from Air Inlet Side of Blower

Installation Instructions (Model JDS9860A**)

8. Install the 6 (15.24 cm) elbow of the blower housing and secure with duct tape. The open end of the elbow should be pointed to the left. Attach the 6 (15.24 cm) flex duct (provided with the range) to the elbow and to the range. Note: For right side venting, the 6 (15.24 cm) diameter flex duct may be cut in half and used in order to make assembly easier.

INSTALLING THE BLOWER

NOTE: *Install the blower prior to installing the range.*

- S Refer to your duct plan. It may be easier to attach part of the ducting to the blower before it is installed.
- S Position the blower and attach to the floor with at least 2 screws.
- S Apply duct tape to blower exhaust duct joint. (See figure 12).

RANGE INSTALLATION

CONNECTING THE DOWNDRAFT BLOWER TO ELECTRICAL (Figure 18)

- S Connect the blower power cord to the blower motor housing.

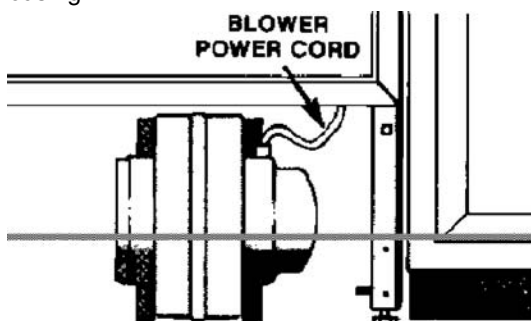

Figure 18

INSTALLING THE FLEX DUCT TO BLOWER

- S Use one of the duct clamps provided. Using a screw driver, tighten duct clamp to secure the flex duct to the inlet of the blower. (See figure 19).

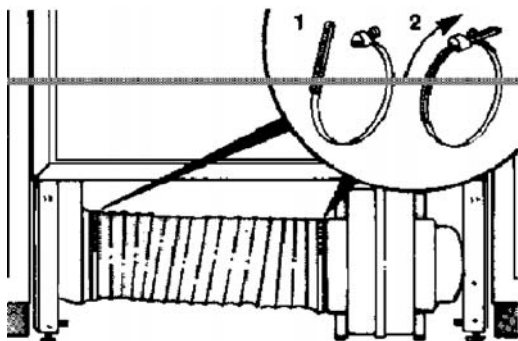

Figure 19

INSTALLING THE RANGE

In The Commonwealth Of Massachusetts

This product must be installed by a licensed plumber or gas fitter when installed within the Commonwealth of Massachusetts.

A "T" handle type manual gas valve must be installed in the gas supply line to this appliance.

A flexible gas connector, when used, must not exceed a length of three (3) feet / 36 inches.

- S Align the range to its designated location and slide back into position. Make sure that the rear leveling leg is fully inserted and secured by the anti-tip bracket.
- S Attach the other end of the flex duct to the plenum of the range using the second duct clamp. Tighten duct clamp to secure it to the plenum.

CHECK FOR OPERATION

- S Install the air filter. As you face the range, the top of the filter should rest against the left side of the vent opening. **DO NOT OPERATE THE SYSTEM WITHOUT THE FILTER.**
- S Install the air grille over the vent opening.
- S Be sure to remove all packing materials the oven from unit prior to applying power.
- S Switch electrical circuit breaker to the ON position.
- S Consult USE and CARE MANUAL for proper operation.

Installation Instructions (Model JDS9860A**)

CONNECTING APPLIANCE TO GAS SUPPLY

A QUALIFIED SERVICEMAN OR GAS APPLIANCE INSTALLER MUST MAKE THE GAS SUPPLY CONNECTION. Leak testing of the appliance shall be conducted by the installer according to the instructions given.

INSTALL GAS SHUTOFF VALVE

Install a manual shutoff valve in an accessible location in the gas line external to this appliance for the purpose of turning on or shutting off gas to the appliance.

Make the gas connection to the inlet of the pressure regulator on this appliance with a 1/2" male pipe thread. Use an approved pipe joint compound resistant to the action of LP gas at pipe connections. Test all joints for gas leaks with a soap and water solution or other accepted leak detection means. Never test for gas leaks with an open flame.

PRESSURE TESTING

The maximum gas supply pressure for the regulator supplied on this appliance is 14" Water Column. The test pressure for checking this regulator must be at least 6" Water Column for natural gas, and at least 11" Water Column for LP. It is shipped from the factory set for natural gas at 5" Water Column.

This appliance and its individual shutoff valve must be disconnected from the gas supply piping system during any pressure testing of that system at test pressures in excess of 1/2 PSIG (3.5 k Pa).

This appliance must be isolated from the gas supply piping system by closing its individual manual shutoff valve during any pressure testing of the gas supply piping system at test pressures equal to or less than 1/2 PSIG (3.5 k Pa).

Appendix B

Use Information (Model JDS8850A**)

OVEN COOKING

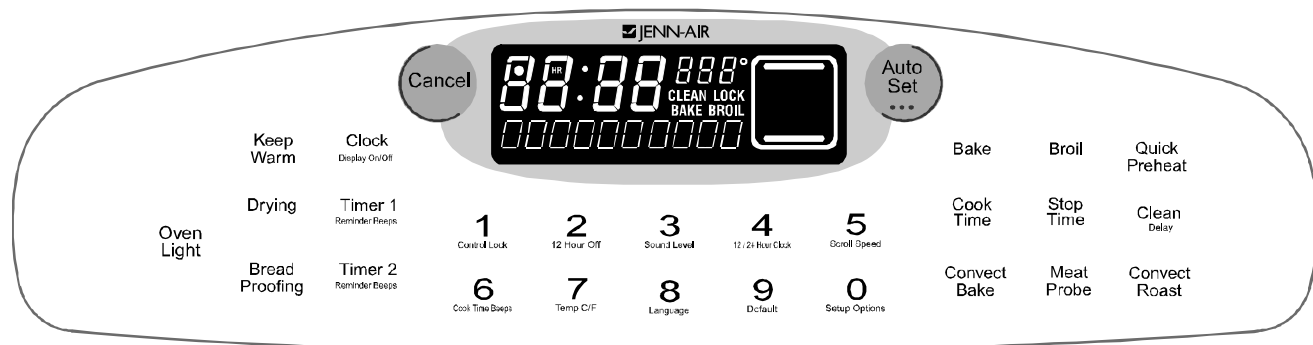

The electronic control is designed for ease in programming. The display window on the control shows time of day, timer and oven functions. Control panel shown includes Convect and other model specific features. (Styling may vary depending on model.)

CAUTION:

- Be sure all packing material is removed from oven before turning on.
- **Prepared Food Warning:** Follow food manufacturer's instructions. If a plastic frozen food container and/or its cover distorts, warps, or is otherwise damaged during cooking, immediately discard the food and its container. The food could be contaminated.
- Follow the manufacturer's directions when using oven cooking bags.
- Do not use oven for storing food or cookware.

NOTE: The temperature or time will be automatically entered four seconds after selection.

If more than 30 seconds elapse between pressing a function pad and the **Auto Set** pad or number pads, the function will be canceled and the display will return to the previous display.

Clock time cannot be changed when the oven has been programmed for clock controlled cooking, self-clean or delayed self-clean.

The clock may be set to a 24-hour clock. See Control Options (12/24 Hour Clock), page 12.

CONTROL OPTIONS

Several control options are indicated under the number pads on the control. Factory-set options can be changed to your preferences. See page 12 for more information.

TIMER PADS

The timer(s) may be set for any time period up to 99 hours and 59 minutes (99:59).

The timer(s) operates independently of any other function and can be set while another oven function is operating. **THE TIMER DOES NOT CONTROL THE OVEN.**

1. Press the **Timer 1** or **2** pad. **TIMER 1** or **2** will flash respectively. 0HR:00 will appear in the display.
2. Press the appropriate number pads to enter desired time.
3. **TIMER 1** or **TIMER 2** will be displayed. If both timers are active, the Timer with the least amount of time left will be displayed.

EXAMPLE: To set a timer for 5 minutes, press the **Timer 1** pad and the number pad 5. The control will begin countdown after a four second delay.

4. The last minute of the countdown will be displayed in seconds.

CONTROL PAD OPERATION

- Press the desired function pad.
- Press the **Auto Set** pad or the appropriate number pad(s) to enter time or temperature.
- A beep will sound when any pad is pressed.
- A double beep will sound if a programming error occurs.
- Further instructions will scroll in display after function pads are pressed.

SETTING CONTROL FUNCTIONS

CLOCK PAD

1. Press **Clock** pad. Indicator word **TIME** will flash in the display.
2. Press the appropriate number pads for the current time.

After a power interruption, **POWER INTERRUPTION** will scroll followed by **SET CLOCK**.

To recall the time of day when another function is showing, press **Clock** pad.

Use Information (Model JDS8850A**)

OVEN COOKING , CONT .

5. At the end of the set time, "END" will be displayed and two chimes will sound followed by two chimes every 30 seconds for up to five minutes. **Press the corresponding Timer pad to cancel the chimes.**

NOTE: The Timer reminder chimes at the end of a set time may be changed. See Control Options (End-of-Timer Signal), page 12.

To Cancel a Set Time:

Press and hold the corresponding **Timer** pad for several seconds. After a slight delay the time of day will appear.

OR

Press the **Timer** pad and the "0" number pad. After a slight delay the timer will be canceled.

CANCEL PAD

Use to cancel all programming except the Clock and Timer functions.

AUTO SET PAD

Use with function pads to automatically set:

- 350 F bake temperature
- 325 F convect bake or roast temperature (select models)
- **hi** or **lo** broil
- three hours of cleaning time
- 140 F drying temperature (select models)
- 160 F probe temperature (select models)
- 170 F keep warm temperature (select models)
- quick or standard bread proofing (select models)
- to change control options

BAKE PAD

Use for baking and roasting.

1. Press **Bake** pad.

2. Press again for 350° F or press the **Auto Set** pad. Each additional press of **Auto Set** will raise the temperature 25° F. Or, press the appropriate number pads for the desired temperature between 100° F and 550° F.

3. When the oven turns on, a red preheat indicator will light and the bake icon will be displayed.



4. A single chime will indicate the oven is preheated to the set temperature. The preheat indicator will turn off.

5. When cooking is complete, press **Cancel** pad. Remove food from oven.

CONVECT BAKE PAD / CONVECT ROAST PAD (SELECT MODELS)

1. Press **Convect Bake** or **Convect Roast** pad.

2. Press again for 325° F or press the **Auto Set** pad. Each additional press of **Auto Set** will raise the temperature 25° F. Or, press the appropriate number pads for the desired temperature between 100° F and 550° F.

3. When the oven turns on, a red preheat indicator will light and the convect icon will be displayed.



NOTE: When the oven is set to preheat for regular baking (either standard or quick preheat), the convect fan will operate during the preheat period. When the oven reaches the selected temperature, the convect fan will shut off. This is normal operation.

4. A single chime will indicate the oven is preheated to the set temperature. The

preheat indicator will turn off.

5. When cooking is complete, press **Cancel** pad. Remove food from oven.

NOTES: BAKING

- To recall the set temperature during preheat press the **Bake** pad.
- To change oven temperature during cooking, press the **Bake** pad and the appropriate number pads.
- Allow 10-12 minutes for the oven to preheat.
- Do not use temperatures below 140° F to keep food warm or below 200° F for cooking. For food safety reasons, lower temperatures are not recommended.
- For additional baking and roasting tips, refer to the "Cooking Made Simple" booklet.

CONVECT BAKING AND ROASTING (select models)

- **Convect Bake** function cycles both the bake and broil elements along with the convection fan at a low speed.
- **As a general rule, when convection baking, set the oven temperature 25° F lower than the conventional recipe or prepared mix directions. Baking time will be the same to a few minutes less than directions.**
- **Convect Roast** function cycles both the bake and broil elements along with the convection fan at a high speed.
- **When roasting meat using the convection setting, roasting times may be up to 30% less.** (Use conventional roasting temperatures.)
- See roasting chart in "Cooking Made Simple" booklet for recommended roasting temperature and times, and additional baking and convection cooking tips.
- **The convection fan will stop whenever the oven door is opened.**

Use Information (Model JDS8850A**)

BROIL PAD

Use for top browning or broiling. For best results, use the broiler pan provided with your range.

1. Press the **Broil** pad.
2. Press the **Auto Set** pad for **hi** broil, press again for **lo** broil, or press the appropriate number pads to set desired broil temperature between 300° and 550° F.
3. For optimal broiling, preheat three to four minutes or until the broil element is red.
4. Place food in oven leaving the oven door open to the first stop position (about four inches).
5. Follow broiling recommendations in "Cooking Made Simple" booklet.
6. When broiling is complete, press **Cancel** pad. Remove food and broiler pan from oven.

COOK TIME /STOP TIME PADS (CLOCK CONTROLLED OVEN COOKING)

Use to program the oven to start and stop automatically. Cook time may be set for up to 11 hours and 59 minutes (11:59). The clock must be functioning and correctly set for this feature to work.

TO START IMMEDIATELY AND TURN OFF AUTOMATICALLY:

1. Press **Cook Time** pad. COOK TIME will flash. Press the appropriate number pads to enter cooking time in hours and minutes.
2. Press the **Bake** or **Convect Bake** or **Convect Roast** (select models) pad and select the temperature. COOK TIME will be displayed along with the temperature.
3. One minute before the end of the programmed cook time, the oven light will turn on. The light will turn off automati-

4. At the end of cook time, the oven will shut off automatically, "End" and COOK TIME will be displayed and three chimes will sound.

5. Press **Cancel** pad. Remove food from oven. If the program is not canceled, there will be two reminder chimes every minute for up to 30 minutes.

NOTE: The Cook Time/Stop Time reminder chimes may be changed. See Control Options (End-of-Cook-Time Signal), page 12.

TO DELAY THE START OF COOKING AND TURN OFF AUTOMATICALLY:

1. Press **Cook Time** pad. COOK TIME will flash. Press the appropriate number pads to enter cooking time in hours and minutes.
2. Press the **Bake** or **Convect Bake** or **Convect Roast** (select models) pad and select the temperature. COOK TIME will be displayed along with the temperature.
3. Press **Stop Time** pad. Display shows when the oven will stop based on an immediate start.

4. Press **Stop Time** pad again. **STOP TIME must be flashing to set the delay start time.**

5. Press the appropriate number pads to enter the time you want the oven to stop.

6. DELAY will be displayed.

7. At the end of the delay period, BAKE and COOK TIME will be displayed along with the temperature.

8. Follow steps 3-5 in preceding section.

QUICK PREHEAT PAD (SELECT MODELS)

Use to decrease preheating time when using the **Bake** or **Convect Bake** pad. Use for all foods when baking on one rack.

- Press the **Quick Preheat** pad. QUICK PREHEAT - 1 RACK BAKING will scroll twice and then PREHEATING will be displayed.

TO RETURN TO STANDARD PREHEAT:

- Press **Quick Preheat** pad again. This will provide standard preheat and the display will scroll STANDARD PREHEAT.

NOTES:

BROILING

- **Hi** broil is used for most broiling. Use **lo** broil when broiling longer cooking foods to allow them to cook to well done stage without excessive browning.
- **A cooling fan will automatically turn on during broiling. If it does not operate, contact an authorized servicer.**
- Never cover broiler pan insert with aluminum foil. This prevents fat from draining to the pan below.

- Expect broil times to be longer and browning to be slightly lighter if appliance is installed on a 208 volt circuit.

CLOCK CONTROLLED OVEN COOKING

- Highly perishable foods such as dairy products, pork, poultry or seafood are not recommended for delayed cooking.
- Clock controlled baking is not recommended for baked items that require a preheated oven, such as cakes, cookies and breads.

Use Information (Model JDS8850A**)

OVEN COOKING , CONT .

KEEP WARM PAD (SELECT MODELS)

For safely keeping foods warm or for warming breads and plates.

1. Press **Keep Warm** pad.
2. Press **Auto Set** pad for 170 ° F or press the appropriate number pads for temperatures between 145° and 190° F.
3. **KEEP WARM** and the temperature selected will be displayed when the function is active.
4. When warming is complete, press **Cancel**.

MEAT PROBE PAD (SELECT MODELS)

To roast and bake items to the desired temperature without over or under cooking.

1. Insert the probe into the food item. (For meats, the probe tip should be located in the center of the thickest part of the meat and not into the fat or touching a bone.)
2. Insert the probe plug into the receptacle located on the top right of the oven. Be certain to insert plug into the receptacle all the way. The control will read **PRESS PROBE PAD**.
3. Press **Probe** Pad.
4. Set the desired internal temperature of the food by pressing **Auto Set** pad for 160° F or press the appropriate number pads for temperature between 100° and 185° F.
5. Press the **Bake**, **Convect Bake**, or **Convect Roast** pad. Press the appropriate number pads for the desired temperature between 100° and 550° F.
6. When the probe has reached the set temperature, the oven will shut off, "END" will be displayed and four chimes will sound followed by one chime every minute for one hour or until the **Cancel** pad is pressed.

BREAD PROOFING PAD (SELECT MODELS)

For proofing or allowing yeast bread products to rise prior to baking. There are two proofing methods available – **STANDARD** and **QUICK**.

Standard Proofing temperature is slightly higher than room temperature, protecting dough from temperature changes and drafts that can affect proofing results.

Quick Proofing provides faster results than countertop or standard proofing, without harming the yeast.

1. Press **Bread Proofing** pad.
2. Press the **Auto Set** pad for Standard Proof, press again for Quick Proof.
3. When proofing is complete, press the **Cancel** pad.

NOTES:

QUICK PREHEAT

- For optimum baking and browning results, Quick Preheat is not recommended when baking on multiple racks.
- For best results, use rack position 2 or 3 when using the Quick Preheat option.

- use only oven-safe plates, check with the manufacturer.
- do not set warm dishes on a cold surface as rapid temperature changes could cause crazing.

KEEP WARM

- For optimal food quality and nutrition, oven cooked foods should be kept warm for no longer than 1 to 2 hours.
- For optimal food quality and color, foods cooked on the range top should be kept warm for an hour or less.
- To keep foods from drying, cover loosely with foil or a lid.

• TO WARM DINNER ROLLS:

- cover rolls loosely with foil and place in oven.
- press **Keep Warm** and **Auto Set** pads.
- warm for 12-15 minutes.

• TO WARM PLATES:

- place 2 stacks of up to four plates each in the oven.
- press **Keep Warm** and **Auto Set** pads.
- warm for five minutes, turn off the oven and leave plates in the oven for 15 minutes more.

MEAT PROBE

- The probe must be removed from the oven when it is not being used.
- Because of the excellent insulation of the oven, the retained heat continues to cook the food after the signal has sounded and the oven has cycled off. For this reason it is important to remove the food from the oven as soon as the signal sounds.
- Use the handle of the probe for inserting and removing. Do not pull on the cable. **Use a potholder to remove since probe becomes hot.**
- For frozen meats, insert probe after 1-2 hours of roasting.
- To clean cooled probe, wipe with a soapy dishcloth. **Do not submerge probe in water or wash in the dishwasher.**

BREAD PROOFING

- For any dough that requires one rise, either Standard or Quick Proofing can be used.
- For dough requiring two rises, Standard Proofing must be used for the first rising period. Either Standard or Quick Proofing can be used for the second rise.

Use Information (Model JDS8850A**)

OVEN COOKING , CONT .

CONTROL OPTIONS

TO CHANGE FACTORY SET DEFAULT OPTIONS:

1. Press the **Setup Options (0)** pad and the desired option pad. (See Options below.)
2. Current option will appear in the display.
3. Press the **Auto Set** pad to change the option.
4. Press any function pad other than the **Cancel** pad to set the displayed option and exit the program.

OPTIONS AVAILABLE :

END -OF-TIMER SIGNAL (TIMER 1 & TIMER 2)

There are three choices for the end of "timer" reminder signals.

- Two chimes (Timer 1) or four chimes (Timer 2) followed by one chime every 30 seconds for up to five minutes (default setting).
- Two chimes (Timer 1) or four chimes (Timer 2) followed by one chime every minute for up to 30 minutes.
- Two chimes (Timer 1) or four chimes (Timer 2) followed by no other chimes.

NOTE: The reminder signal chosen will apply to both timers.

CONTROL LOCK (1)

The function pads on the control can be locked to prevent unwanted use for safety and cleaning benefits. Control Lock will not lock out the Timer, Clock or Oven Light.

12 HOUR OFF/SABBATH MODE (2)

The oven may be set to turn off after 12 hours or stay on indefinitely. The default is set to turn off after 12 hours.

SOUND LEVEL (3)

The sound of the chimes may be changed with **IIIIIIII(8)** being the highest volume and **I(1)** being the lowest. The default is set at level 6.

12/24 HOUR CLOCK (4)

The clock may be set for a 12-hour or 24-hour clock. The default is set for a 12-hour clock.

SCROLL SPEED (5)

The scroll speed of the messages in the display may be changed from **FAST** to **MEDIUM** to **SLOW**. The default is set for the medium speed.

END -OF-COOK TIME SIGNAL (6)

There are three choices for the end of "clock controlled cooking" reminder signals.

- Three chimes followed by two chimes every minute for up to 30 minutes (default setting).
- Three chimes followed by no other chimes.
- Three chimes followed by two chimes every 30 seconds for up to five minutes.

TEMP C/F (7)

The temperature scale may be changed to **Centigrade** or **Fahrenheit**. The default is set for Fahrenheit.

LANGUAGE (8)

The words which scroll in the display may be changed from English to French or Spanish.

DEFAULT (9)

The control can be reset to restore the factory setting for each option.

DISPLAY ON/OFF (CLOCK)

The time-of-day display may be shut off when the oven is not in a cooking or cleaning function.

OVEN TEMPERATURE ADJUSTMENT

If you think the oven is operating too cold or hot, you can adjust it. Bake several test items and then adjust the temperature setting not more than 10° F at a time.

TO ADJUST:

1. Press the **Bake** pad and enter 550° F.
2. Press and hold the **Bake** pad for several seconds until **TEMP ADJ** is displayed.
3. Press the **Auto Set** pad - each press changes the temperature by 5° F. The control will accept changes from -35° to +35° F.
4. If the oven was previously adjusted, the change will be displayed. For example, if the oven temperature was reduced by 15° F, the display will show -15° F.
5. When you have made the adjustment, press any function pad, **OPTION CHANGED** will scroll and the time of day will reappear in the display. The oven will now bake at the adjusted temperature.

NOTE: It is not recommended to change the oven temperature if only one or two recipes are in question.

OVEN LIGHT

The oven light automatically comes on when the door is opened. When the door is closed, press the **Oven Light** pad on the control panel to turn the light on or off.

The oven light will come on automatically one minute before the end of a clock controlled cooking operation.

Use Information (Model JDS9860A**)

OVEN COOKING

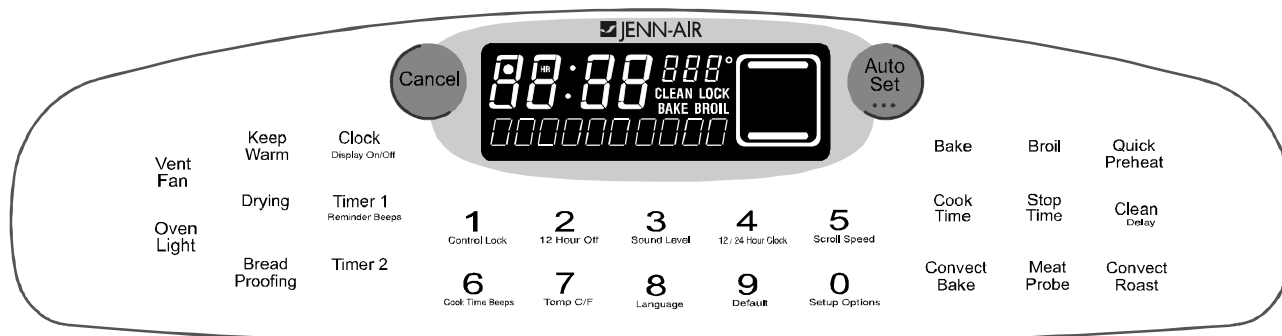

The electronic control is designed for ease in programming. The display window on the control shows time of day, timer and oven functions.

CONTROL PAD OPERATION

- Press the desired function pad.
- Press the **Auto Set** pad or the appropriate number pad(s) to enter time or temperature.
- A beep will sound when any pad is pressed.
- A double beep will sound if a programming error occurs.
- Further instructions will scroll in display after function pads are pressed.

NOTE: The temperature or time will be automatically entered four seconds after selection.

If more than 30 seconds elapse between pressing a function pad and the **Auto Set** pad or number pads, the function will be canceled and the display will return to the previous display.

CONTROL OPTIONS

Several control options are indicated under the number pads on the control. Factory-set options can be changed to your preferences. See page 16 for more information.

SETTING CONTROL FUNCTIONS

CLOCK PAD

1. Press **Clock** pad. Indicator word TIME will flash in the display.
2. Press the appropriate number pads for the current time.

After a power interruption, POWER INTERRUPTION will scroll followed by SET CLOCK.

To recall the time of day when another function is showing, press **Clock** pad.

Clock time cannot be changed when the oven has been programmed for clock controlled cooking, self-clean or delayed self-clean.

The clock may be set to a 24-hour clock. See Control Options (12/24 Hour Clock), page 16.

TIMER PADS

The timer(s) may be set for any time period up to 99 hours and 59 minutes (99:59).

The timer(s) operates independently of any other function and can be set while another oven function is operating. **THE TIMER DOES NOT CONTROL THE OVEN.**

1. Press the **Timer 1** or **2** pad. **TIMER 1** or **2** will flash respectively. 0HR:00 will appear in the display.

2. Press the appropriate number pads to enter desired time.
3. **TIMER 1** or **TIMER 2** will be displayed. If both timers are active, the Timer with the least amount of time left will be displayed.
EXAMPLE: To set a timer for 5 minutes, press the **Timer 1** pad and the number pad 5. The control will begin countdown after a four second delay.
4. The last minute of the countdown will be displayed in seconds.
5. At the end of the set time, "END" will be displayed and two chimes will sound followed by one chime every 30 seconds for up to five minutes. **Press the corresponding Timer pad to cancel the chimes.**

NOTE: The Timer reminder chimes at the end of a set time may be changed. See Control Options (End-of-Timer Signal), page 16.

To Cancel a Set Time:

Press and hold the corresponding **Timer** pad for several seconds. After a slight delay the time of day will appear.

OR

Press the **Timer** pad and the "0" number pad. After a slight delay the timer will be canceled.

Use Information (Model JDS9860A**)

OVEN COOKING , CONT .

CANCEL PAD

Use to cancel all programming except the Clock and Timer functions.

AUTO SET PAD

Use with function pads to automatically set:

¥350° F bake temperature

¥325° F convect bake or roast temperature

¥hi or lo broil

¥ three hours of cleaning time

¥140° F drying temperature

¥160° F probe temperature

¥170° F keep warm temperature

¥ quick or standard bread proofing

¥ to change control options

BAKE PAD

Use for baking and roasting.

1. Press **Bake** pad.

2. Press again for 350° F or press the **Auto Set** pad. Each additional press of **Auto Set** will raise the temperature 25° F. Or, press the appropriate number pads for the desired temperature between 100° F and 550° F.

3. When the oven turns on, a red preheat indicator will light and the bake icon will be displayed.



4. A single chime will indicate the oven is preheated to the set temperature. The preheat indicator will turn off.

5. When cooking is complete, press **Cancel** pad. Remove food from oven.

CONVECT BAKE PAD / CONVECT ROAST PAD

1. Press **Convect Bake** or **Convect Roast** pad.

2. Press again for 325° F or press the **Auto Set** pad. Each additional press of **Auto Set** will raise the temperature 25° F. Or, press the appropriate number pads for the desired temperature between 100° F and 550° F.

3. When the oven turns on, a red preheat indicator will light and the convect icon will be displayed.



4. A single chime will indicate the oven is preheated to the set temperature. The preheat indicator will turn off.

5. When cooking is complete, press **Cancel** pad. Remove food from oven.

BROIL PAD

Use for top browning or broiling. For best results, use the broiler pan provided with your range.

1. Press the **Broil** pad.

2. Press the **Auto Set** pad for hi broil, press again for lo broil, or press the appropriate number pads to set desired broil temperature between 300° and 550° F.

3. For optimal broiling, preheat three to four minutes or until the broil element is red.

NOTES:

BAKING

¥ To recall the set temperature during preheat press the **Bake** pad.

¥ To change oven temperature during cooking, press the **Bake** pad and the appropriate number pads.

¥ Allow 10-12 minutes for the oven to preheat.

¥ Do not use temperatures below 140° F to keep food warm or below 200° F for cooking. For food safety reasons, lower temperatures are not recommended.

¥ For additional baking and roasting tips, refer to the **OCooking Made SimpleO** booklet.

CONVECT BAKING AND ROASTING

¥ **Convect Bake** function cycles both the bake and broil elements along with the convection fan at a low speed.

¥ As a general rule, when convection baking, set the oven temperature 25° F lower than the conventional recipe or prepared mix directions. Baking time will be the same to a few minutes less than directions.

¥ **Convect Roast** function cycles both the bake and broil elements along with the convection fan at a high speed.

¥ When roasting meat using the convection setting, roasting times may be up to 30% less. (Maintain conventional roasting temperatures.)

¥ See roasting chart in **OCooking Made SimpleO** booklet for recommended roasting temperature and times, and additional baking and convection cooking tips.

¥ The convection fan will stop whenever the oven door is opened.

Use Information (Model JDS9860A**)

- Place food in oven leaving the oven door open to the first stop position (about four inches).
- Follow broiling recommendations in "Cooking Made Simple" booklet.
- When broiling is complete, press **Cancel** pad. Remove food and broiler pan from oven.

COOK TIME /STOP TIME PADS (CLOCK CONTROLLED OVEN COOKING)

Use to program the oven to start and stop automatically. Cook time may be set for up to 11 hours and 59 minutes (11:59). The clock must be functioning and correctly set for this feature to work.

TO START IMMEDIATELY AND TURN OFF AUTOMATICALLY:

- Press **Cook Time** pad. COOK TIME will flash. Press the appropriate number pads to enter cooking time in hours and minutes.
- Press the **Bake** or **Convection Bake** or **Convection Roast** pad and select the temperature. COOK TIME will be displayed along with the temperature.
- One minute before the end of the programmed cook time, the oven light will turn on. The light will turn off automatically when **Cancel** pad is pressed or after oven door is opened and closed.
- At the end of cook time, the oven will shut off automatically, "End" and COOK TIME will be displayed and three chimes will sound.
- Press **Cancel** pad. Remove food from oven. If the program is not canceled, there will be two reminder chimes every minute for up to 30 minutes.

NOTE: The Cook Time/Stop Time reminder chimes may be changed. See Control Options (End-of-Cook Time Signal), page 16.

TO DELAY THE START OF COOKING AND TURN OFF AUTOMATICALLY:

- Press **Cook Time** pad. COOK TIME will flash. Press the appropriate number pads to enter cooking time in hours and minutes.
- Press the **Bake** or **Convection Bake** or **Convection Roast** pad and select the temperature. COOK TIME will be displayed along with the temperature.
- Press **Stop Time** pad. Display shows when the oven will stop based on an immediate start.
- Press **Stop Time** pad again. **STOP TIME must be flashing to set the delay start time.**
- Press the appropriate number pads to enter the time you want the oven to stop.
- DELAY will be displayed.

- At the end of the delay period, BAKE and COOK TIME will be displayed along with the temperature.
- Follow steps 3-5 in preceding section.

QUICK PREHEAT PAD

Use to decrease preheating time when using the **Bake** or **Convection Bake** pads. Use for all foods when baking on one rack.

- Press the **Bake** or **Convection Bake** pad and select the temperature.
- Press the **Quick Preheat** pad. QUICK PREHEAT - 1 RACK BAKING will scroll twice and then PREHEATING will be displayed.

TO RETURN TO STANDARD PREHEAT:

- Press **Quick Preheat** pad again. This will provide standard preheat and the display will scroll STANDARD PREHEAT.

NOTES:

BROILING

- Hi** broil is used for most broiling. Use **lo** broil when broiling longer cooking foods to allow them to cook to well done stage without excessive browning.
- A cooling fan will automatically turn on during broiling. If it does not operate, contact an authorized servicer.**
- Never cover broiler pan insert with aluminum foil. This prevents fat from draining to the pan below.
- Expect broil times to be longer and browning to be slightly lighter if appliance is installed on a 208 volt circuit.

CLOCK CONTROLLED OVEN COOKING

- Highly perishable foods such as dairy products, pork, poultry or seafood are not recommended for delayed cooking.
- Clock controlled baking is not recommended for baked items that require a preheated oven, such as cakes, cookies and breads.

QUICK PREHEAT

- For best results, use rack position 2 or 3 when using the Quick Preheat option.
- For optimum baking and browning results, Quick Preheat is not recommended when baking on multiple racks.

Use Information (Model JDS9860A**)

OVEN COOKING , CONT .

KEEP WARM PAD

For safely keeping foods warm or for warming breads and plates.

1. Press **Keep Warm** pad.
2. Press **Auto Set** pad for 170° F or press the appropriate number pads for temperatures between 145° and 190° F.
3. **KEEP WARM** and the temperature selected will be displayed when the function is active.
4. Press **Cancel** when warming is complete.

Meat PROBE PAD

To roast and bake items to the desired temperature without over or under cooking.

1. Insert the probe into the food item. (For meats, the probe tip should be located in the center of the thickest part of the meat and not into the fat or touching a bone.)
2. Insert the probe plug into the receptacle located on the top right of the oven. Be certain to insert plug into the receptacle all the way. The control will read **PRESS PROBE PAD**.
3. Press **Probe** pad.
4. Set the desired internal temperature of the food by pressing **Auto Set** pad for 160° F or press the appropriate number pads for temperature between 100° and 185° F.
5. Press the **Bake**, **Convect Bake**, or **Convect Roast** pad. Press the appropriate number pads for the desired temperature between 100° and 550° F.
6. When the probe has reached the set temperature, the oven will shut off, **ÖENDÓ** will be displayed and four chimes will sound followed by one chime every minute for one hour or until the **Cancel** pad is pressed.

BREAD PROOFING PAD

For proofing or allowing yeast based bread products to rise prior to baking. There are two proofing methods available – **STANDARD** and **QUICK**.

Standard Proofing in the oven protects dough from room temperature changes or drafts that commonly affect proofing done on the countertop.

Quick Proofing provides faster proofing results than countertop or standard proofing, without harming the yeast.

1. Press **Bread Proofing** pad.
2. Press the **Auto Set** pad for Standard Proof, press again for Quick Proof.
3. When proofing is complete, press **Cancel** pad.

NOTES:

KEEP WARM

- ¥ For optimal food quality, oven cooked foods should be kept warm for no longer than 1 to 2 hours.
- ¥ For optimal food quality and color, foods cooked on the range top should be kept warm for an hour or less.
- ¥ To keep foods from drying, cover loosely with foil or a lid.

¥TO WARM DINNER ROLLS:

- cover rolls loosely with foil and place in oven.
- press **Keep Warm** and **Auto Set** pads.
- warm for 12-15 minutes.

¥ TO WARM PLATES:

- place 2 stacks of up to four plates each in the oven.
- press **Keep Warm** and **Auto Set** pads.
- warm for five minutes, turn off the oven and leave plates in the oven for 15 minutes more.
- use only oven-safe plates, check with the manufacturer.
- do not set warm dishes on a cold surface as rapid temperature changes could cause crazing.

MEAT PROBE

- ¥ The probe must be removed from the oven when it is not being used.
- ¥ Because of the excellent insulation of the oven, the retained heat continues to cook the food after the signal has sounded and the oven has cycled off. For this reason it is important to remove the food from the oven as soon as the signal sounds.
- ¥ Use the handle of the probe for inserting and removing. Do not pull on the cable. **Use a potholder to remove since probe becomes hot.**
- ¥ For frozen meats, insert probe after 1-2 hours of roasting.
- ¥ To clean cooled probe, wipe with a soapy dishcloth. **Do not submerge probe in water or wash in the dishwasher.**

BREAD PROOFING

- ¥ For any dough that requires one rise, either Standard or Quick Proofing can be used.
- ¥ For dough requiring two rises, Standard Proofing must be used for the first rising period. Either Standard or Quick Proofing can be used for the second rise.

Use Information (Model JDS9860A**)

OVEN COOKING , CONT .

CONTROL OPTIONS

1. Press the **Setup Options (0)** pad and the desired option pad. (See Options below.)
2. Current option will appear in the display.
3. Press the **Auto Set** pad to change the option.
4. Press any function pad other than the **Cancel** pad to set the displayed option and exit the program.

OPTIONS AVAILABLE

End-of-Timer SIGNAL (TIMER 1 AND TIMER 2)

There are three choices for the end of "timer" reminder signals.

- Two chimes (Timer 1) or four chimes (Timer 2) followed by one chime every 30 seconds for up to five minutes (default setting).
- Two chimes (Timer 1) or four chimes (Timer 2) followed by one chime every minute for up to 30 minutes.
- Two chimes (Timer 1) or four chimes (Timer 2) followed by no other chimes.

NOTE: The reminder signal chosen will apply to both timers.

CONTROL LOCK (1)

The function pads on the control can be locked to prevent unwanted use for safety and cleaning benefits. Control Lock will not lock out the Timer, Clock or Oven Light.

12 HOUR OFF/SABBATH MODE (2)

The oven may be set to turn off after 12 hours or stay on indefinitely. The default is set to turn off after 12 hours.

SOUND LEVEL (3)

The sound of the chimes may be changed with **IIIIIIII(8)** being the highest volume and **I(1)** being the lowest. The default is set at level 6.

12/24 HOUR CLOCK (4)

The clock may be set for a 12-hour or 24-hour clock. The default is set for a 12-hour clock.

SCROLL SPEED (5)

The scroll speed of the messages in the display may be changed from **FAST** to **MEDIUM** to **SLOW**. The default is set for the medium speed.

END -OF-COOK TIME SIGNAL (6)

There are three choices for the end of "clock controlled cooking" reminder signals.

- Three chimes followed by two chimes every minute for up to 30 minutes (default setting).
- Three chimes followed by no other chimes.
- Three chimes followed by two chimes every 30 seconds for up to five minutes.

TEMP C/F (7)

The temperature scale may be changed to Centigrade or Fahrenheit. The default is set for Fahrenheit.

LANGUAGE (8)

The words which scroll in the display may be changed from English to French or Spanish.

DEFAULT (9)

The control can be reset to restore the factory setting for each option.

DISPLAY ON/OFF (CLOCK)

The time-of-day display may be shut off when the oven is not in a cooking or cleaning function.

OVEN TEMPERATURE ADJUSTMENT

If you think the oven is operating too cold or hot, you can adjust it. Bake several test items and then adjust the temperature setting not more than 10° F at a time.

TO ADJUST:

1. Press the **Bake** pad and enter 550° F.
2. Press and hold the **Bake** pad for several seconds until **TEMP ADJ** is displayed.
3. Press the **Auto Set** pad - each press changes the temperature by 5° F. The control will accept changes from -35° to +35° F.
4. If the oven was previously adjusted, the change will be displayed. For example, if the oven temperature was reduced by 15° F, the display will show -15° F.
5. When you have made the adjustment, press any function pad, **OPTION CHANGED** will scroll and the time of day will reappear in the display. The oven will now bake at the adjusted temperature.

NOTE: It is not recommended to adjust the temperature if only one or two recipes are in question.

OVEN LIGHT

The oven light automatically comes on when the door is opened. When the door is closed, press the **Oven Light** pad on the control panel to turn the light on or off.

The oven light will come on automatically one minute before the end of a clock controlled cooking operation.

Care Information

CARE & CLEANING

CLEAN PAD

Use to set a self-clean cycle or a delayed self-clean cycle. One press of the **Clean** pad sets up an immediate clean cycle. A second press of the **Clean** pad sets up a delayed clean cycle.

- Clean oven frame, door frame (area outside of gasket) and around the opening in the door gasket with a non-abrasive cleaner such as Bon Ami*. These areas are not exposed to cleaning temperatures.
- Remove air grille.
- **Remove oven racks.** If racks are left in during a clean cycle, it may impair function and they will discolor. Turn off the oven light and close door.

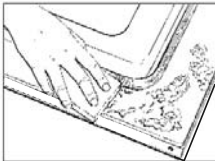

* Brand names for cleaning products are registered trademarks of the respective manufacturers.

TO SET FOR IMMEDIATE START:

1. Press **Clean** pad once.
2. Press the **Auto Set** pad for 3 hours of cleaning time, press again for 4 hours and again if 2 hours of clean time are desired.
3. **CLEANING** and **LOC** plus the clean time will appear in the display.
4. When the clean cycle is complete, **CLEANED** will be displayed. **LOC** will remain on until the oven has cooled (approx. 1 hour).
5. When the oven is cool, **LOC** will no longer be displayed and the door may be opened.
6. Wipe out the oven interior with a damp cloth. If soil remains it indicates the cycle was not long enough.

TO CANCEL SELF-CLEAN:

1. Press **Cancel** pad.
2. If **LOC** is NOT displayed, open oven door. If **LOC** is displayed, allow oven to cool.

TO SET FOR DELAY START:

1. Press **Clean** pad twice.
2. Press the **Auto Set** pad to program a 2-hour delay. Each additional press of **Auto**

Set will add 2-hours up to a total delay of eight hours from the current time.

3. The start time and the time of day will be displayed during the delay period.
4. At the end of the delay period, **CLEANING**, **LOC** and the clean time will appear in the display.
5. Follow steps 4-6 in preceding section.

NOTES:

- To prevent damage to oven door, do not attempt to open oven door when the **LOC** indicator word is displayed.
- During the cleaning process, the kitchen should be well ventilated to help eliminate normal odors associated with cleaning. Odors will lessen with use.
- It is normal for flare-ups, smoking or flaming to occur during cleaning if the oven is heavily soiled. It is better to clean the oven regularly rather than to wait until there is a heavy buildup of soil.
- Wipe up excess grease or spillovers to prevent flare-ups. For ease in cleaning, the bake element in the oven can be lifted slightly (1 inch).
- It is normal for parts of the range to become hot during a clean cycle. Avoid touching cooktop, door, window or oven vent area during a clean cycle.
- A cooling fan will automatically turn on during cleaning. If it does not operate, contact an authorized servicer.
- Wipe up sugary and acidic spillovers such as sweet potatoes, tomato or milk-based sauces prior to a self-clean cycle. Porcelain enamel is acid resistant, not acid proof and may discolor if spills are not wiped up before a self-clean cycle.
- A white discoloration may appear after cleaning if acidic or sugary foods are not wiped up before the clean cycle. This discoloration is normal and will NOT affect performance.

Care Information

CARE & CLEANING , CONT .

CLEANING PROCEDURES



- Be sure appliance is off and all parts are cool before handling or cleaning. This is to avoid damage and possible burns.
- To prevent staining or discoloration, clean appliance after each use.
- If a part is removed, be sure it is correctly replaced.

ACCESS PANEL

The access panel is easily opened or removed. To open panel, grasp upper corners and pull forward and down. To close panel, lift up and insert prongs into catches in the range.

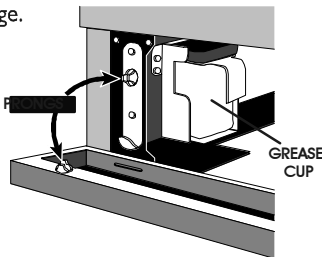

- Wash with soap and water, a glass cleaner, or mild liquid sprays.
- Do not use excessive amounts of water.
- To prevent scratching or dulling of the finish, do not use mildly abrasive, abrasive, harsh or caustic cleaners such as oven cleaners.

NOTE: To avoid the possibility of accidentally disconnecting any part of the ventilation system, do not use the area behind the access panel for storage.

BROILER PAN AND INSERT

- Place soapy cloth over insert and pan; let soak to loosen soil.
- Wash in warm soapy water. Use scouring pad to remove stubborn soil.
- Broiler pan and insert can be cleaned in dishwasher.

* Brand names for cleaning products are registered trademarks of the respective manufacturers.

** To order direct, call 1-800-688-8408.

CLOCK AND CONTROL PAD AREA

- To activate "Control Lock" for cleaning, see page 16.
- Wipe with a damp cloth and dry.
- Glass cleaners may be used if sprayed on a cloth first. **DO NOT spray directly on control pad and display area.**

CONTROL PANEL

- Wipe with damp cloth.
- For stubborn soil, use mildly abrasive cleaning agents such as Bon Ami*. Do NOT use abrasive cleaners such as steel wool pads or oven cleaners. These products will permanently damage the surface.

CONTROL KNOBS

- Remove knobs in the OFF position by pulling forward.
- Wash, rinse and dry. Do not use abrasive cleaning agents as they may scratch the finish.
- Turn on each burner to be sure the knobs have been correctly replaced.

COOKTOP & SEALED GAS BURNER CARTRIDGE - PORCELAIN ENAMEL

Porcelain enamel is glass fused on metal and may crack or chip with misuse. It is acid resistant, not acid proof. All spills, especially acid or sugar spills, should be wiped up immediately with a dry cloth.

- When cool, wash with soapy water, rinse and dry.
- Never wipe off a warm or hot surface with a damp cloth. This may cause cracking or chipping.
- Never use oven cleaners, abrasive or caustic cleaning agents on exterior finish of range.

DOOR HANDLE - PLASTIC FINISHES

- When cool, clean with soap and water, rinse and dry.
- Use a glass cleaner and a soft cloth.

NOTE: Never use oven cleaners, abrasive or caustic liquid or powdered cleansers on plastic finishes. These cleaning agents will scratch or mar finish.

NOTE: To prevent staining or discoloration, wipe up fat, grease or acid (tomato, lemon, vinegar, milk, fruit juice, marinade) immediately with a dry paper towel.

OVEN WINDOW & DOOR - GLASS

- Avoid using excessive amounts of water which may seep under or behind glass causing staining.
- Wash with soap and water. Rinse with clear water and dry. Glass cleaner can be used if sprayed on a cloth first.
- Do not use abrasive materials such as scouring pads, steel wool or powdered cleaners as they will scratch glass.

OVEN INTERIORS

- Follow instructions on page 18 to set a self-clean cycle.

OVEN RACKS

- Clean with soapy water.
- Remove stubborn soil with cleansing powder or soap-filled scouring pad. Rinse and dry.
- If over time, racks do not slide out easily, wipe the rack edge and rack support with a small amount of vegetable oil to restore ease of movement, then wipe off excess oil. Likewise, place one drop of vegetable oil on rack guides.

NOTE: Remove oven racks during a clean cycle. If racks are left in the oven, it may impair function and they will discolor.

Care Information

SEALED GAS BURNER

ASSEMBLY

- Allow burner and grates to cool. Wash with soapy water and a plastic scouring pad. For stubborn soils, clean with a soap-filled, nonabrasive pad or a sponge and a commercial Cooktop Cleaning Creme (Part #20000001)**.
- Clean gas ports with a soft bristle brush or straight pin, especially the port below the ignitor. Do not enlarge or distort holes.
- Be careful not to get water into burner ports.
- When cleaning, use care to prevent damage to the ignitor. If the ignitor is soiled, wet or damaged the surface burner will not light.

STAINLESS STEEL

(SELECT MODELS)

- **DO NOT USE ANY CLEANING PRODUCT CONTAINING CHLORINE BLEACH.**
- **ALWAYS WIPE WITH THE GRAIN WHEN CLEANING.**
- **Daily Cleaning/Light Soil** — Wipe with one of the following - soapy water, white vinegar/water solution, Formula 409 Glass and Surface Cleaner* or a similar glass cleaner - using a sponge or soft cloth. Rinse and dry. To polish and help prevent fingerprints, follow with Stainless Steel Magic Spray (Jenn-Air Model A912, Part No. 20000008)**.
- **Moderate/Heavy Soil** — Wipe with one of the following - Bon Ami, Smart Cleanser, or Soft Scrub* - using a damp sponge or soft cloth. Rinse and dry. Stubborn soils may be removed with a damp Scotch-Brite* pad; rub evenly with the grain. Rinse and dry. To restore luster and remove streaks, follow with Stainless Steel Magic Spray.

- **Discoloration** — Using a damp sponge or soft cloth, wipe with Cameo Stainless Steel Cleaner*. Rinse immediately and dry. To remove streaks and restore luster, follow with Stainless Steel Magic Spray.

GRILL ASSEMBLY —

BASIN — PORCELAIN

The basin is located under the grill burner and/or cartridges. Clean after each use of the grill.

- To remove light soil, clean with soapy water or spray with cleansers such as Fantastik* or Formula 409*. For easier cleanup: **a)** spray with a household cleanser; **b)** cover with paper towels; **c)** add small amount of hot water to keep the paper towels moist; **d)** cover and wait 15 minutes; and **e)** wipe clean.
- To remove moderate soil, scrub with Bon Ami*, a soft scrub cleanser or plastic scrubber.

Note: Check the grease drain after each use of the grill. To clean: Pour about 1/3 cup of very hot tap water mixed with 1 teaspoon dish detergent down the drain.

GRATES — CAST ALUMINUM COATED WITH NON-STICK

FINISH

- Wash cool grates (**DO NOT IMMERSE HOT GRILL GRATES IN WATER**) with detergent in hot water in the sink or wash them in the dishwasher. Be sure to remove all food residue before cooking on the grill grates again.
- Remove stubborn soils with a plastic mesh puff or pad. Use only those cleaning products which state they are recommended for use when cleaning nonstick surfaces.

- If grates were washed in the dishwasher, season with oil prior to grilling.
- Do not use metal brushes or abrasive scouring pads or other scrubbers intended to clean outdoor charcoal grills. These will remove the finish as well as scratch the grates. Do not clean in self-cleaning oven or use oven cleaners on the grates.

GRILL BURNER

- Follow instructions on page 7 for removing the grill burner.
- The grill burner should be cleaned after each use with a soapy S.O.S.* pad. Rinse and dry thoroughly before using again.

NOTE: Check to be sure all burner ports are open. To open clogged ports, insert a straight pin into each port.

GREASE CUP

- The container is located on the left side behind the bottom access panel, underneath the range. (See page 19 for opening access panel.) It collects grease and other liquids created while grilling. Check each time after grilling and empty when grease is noticeable. To remove, simply grasp the handle, and pull from the bracket holding the container.
- The container can be washed in hot, soapy water or in the dishwasher.

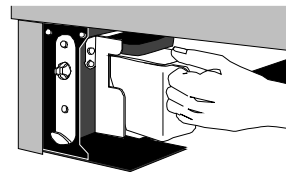

* Brand names for cleaning products are registered trademarks of the respective manufacturers.

** To order direct, call 1-800-688-8408.

Appendix C

LP Conversion Instructions

GAS CONVERSION

General

All ranges and cooktops are equipped with double coaxial (universal) orifices and with a convertible appliance pressure regulator. The unit model number plate states which gas it was adjusted for at the factory. To convert the unit to either Natural gas or LP gas will require adjustment of the orifice hoods, air shutters on the burners and adjustment of the appliance pressure regulator converter cap.

Inlet pressure to the appliance pressure regulator should be as follows for both operation and checking of appliance pressure regulator setting:

<u>INLET PRESSURE IN INCHES OF WATER COLUMN</u>	<u>NATURAL GAS</u>	<u>LP GAS</u>
Minimum	6	11
Maximum	14	14

WARNING

Gas leaks may occur in your system and result in a dangerous situation. Gas leaks may not be detected by smell alone. Gas suppliers recommend you purchase and install an UL approved gas detector. Install and use in accordance with the manufacturer's instructions.

Appliance Pressure Regulator Conversion

The unit appliance pressure regulator must be set to match the type gas supply used. If converting from natural gas to LP gas, the appliance pressure regulator must be converted to regulate LP gas. If converting from LP gas to natural gas, the appliance pressure regulator must be converted to regulate natural gas.

To convert the appliance pressure regulator from one gas to another, do either (1), (2) or (3) below: Your unit will be equipped with one of the three appliance pressure regulator types shown below.

1. Remove the cap, push down and turn counter-clockwise. Turn the cap over and reinstall (figure 10).

NOTE: The gas type you are converting to must be visible on the top of the installed appliance pressure regulator cap.

2. Remove plastic dust cover from cap nut on top of appliance pressure regulator. Remove cap nut from appliance pressure regulator (plastic dust cover comes off with nut). "IMPORTANT" remove plastic dust cover from cap nut and reinstall on opposite side of cap nut.

Reinstall cap nut to appliance pressure regulator and replace dust cover. "**CAUTION**" be sure marking for the type of gas to which appliance pressure regulator has just been converted is visible in top of cap nut before replacing plastic dust cover. (See figure 11).

3. Remove cap and forcibly snap out plastic plunger from bottom of cap. Turn plunger over and forcibly snap back in original location (figure 12).

NOTE: Plunger **MUST** snap into position; the gas type you are converting to must be visible on lower side of plunger.

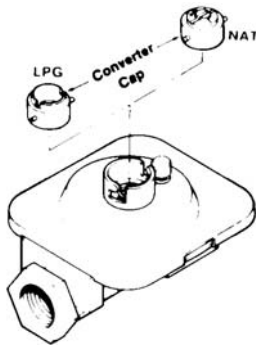

FIGURE 10

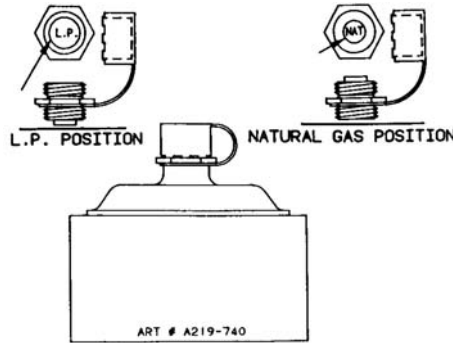

FIGURE 11

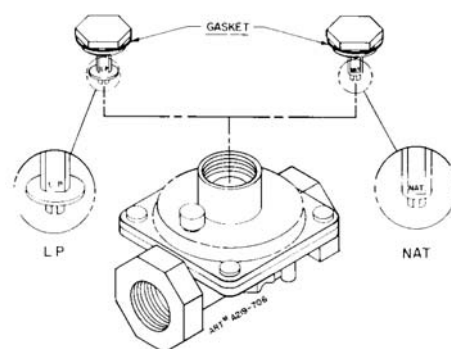

FIGURE 12

LP Conversion Instructions

ORIFICE CONVERSION

1. From Natural Gas To LP/Propane Gas:

- a. Change the appliance pressure regulator from natural to LP setting. (See figures 10, 11 or 12).
- b. Screw the burner orifice hoods down tight against the pins. (See figure 13B). Use care to not over tighten. Over tightening can damage the coaxial pin inside the orifice hood.

NOTE: On units using Eaton Oven Safety Valve, screw the valve orifice hood down tight against the valve body. (See figure 13D). It is important that the hood be turned down as far as it can go to insure that complete conversion has occurred.

- c. Adjust burner air shutter to the widest opening that will not cause the flame to lift or blow off the burner when cold.

NOTE: Correctly adjusted sealed burners, can have flames that will lift or blow without a pot over the burner. These should be adjusted with a pot in place.

2. From LP/Propane Gas To Natural Gas:

- a. Change the appliance pressure regulator from LP to natural setting. (See figures 10, 11 or 12).
- b. Screw the burner orifice hoods away from the pins. (See figure 13A). Approximately 1 1/2 to 2 turns.

NOTE: On units using Eaton Oven Safety Valve, screw the burner orifice hoods away from pin (see figure 13C). Approximately 1 1/2 to 2 turns.

- c. Adjust burner air shutter to the widest opening that will not cause the flame to lift or blow off the burner when cold.

NOTE: Correctly adjusted sealed burners, the flame will lift or blow without a pot over the burner. These should be adjusted with a pot in place.

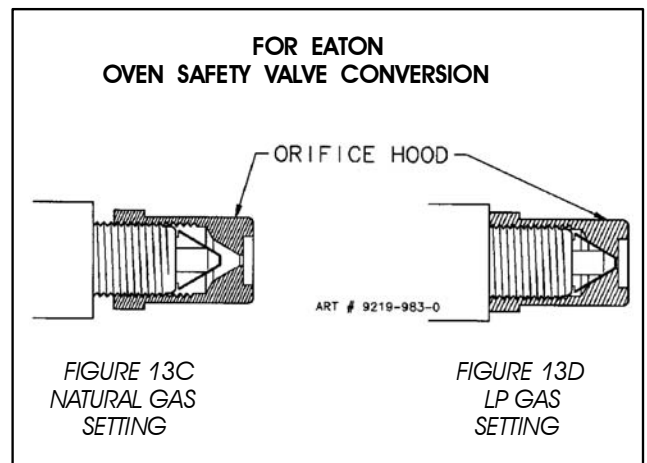
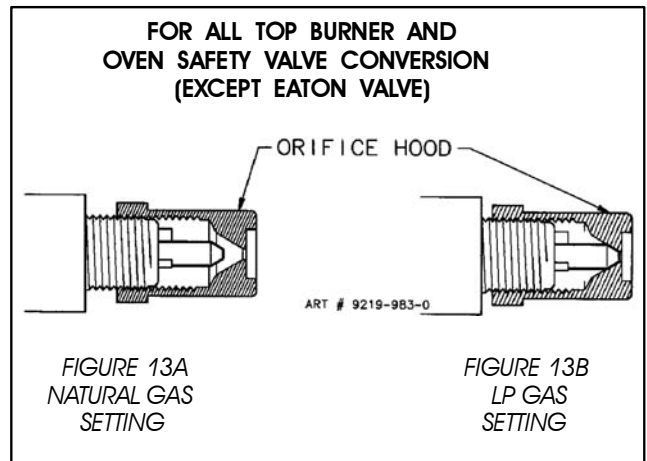

High Altitude Notice

The specified gas burner ratings typically apply to elevations up to 2000 feet. For higher altitudes, the rates may need to be reduced to achieve satisfactory operation. A local certified gas servicer will be able to advise if a reduction is necessary.

LP Conversion Instructions

SURFACE BURNER HEADS AND BURNER BASES

- S The surface burner heads are removable. The cap portion of the head is porcelain and the port area is aluminum. Wash the burner heads in the sink with mild detergent and a plastic scrubber. For stubborn stains, clean with Cooktop Cleaning Creme (Part #20000001).
- S Check to be sure all ports are open. To open clogged ports, insert a straight pin directly into each port. Do not enlarge or distort the port.
- S The aluminum burner base is not removeable. To clean, wipe with a damp cloth.
- S When replacing the burner heads, carefully align the tab on the burner base with the indentation in the head. The two pins will fit in the slots when the tab is aligned with the indentation.

NOTE: When burner heads are removed for cleaning, do not spill liquids through the holes in the burner base.

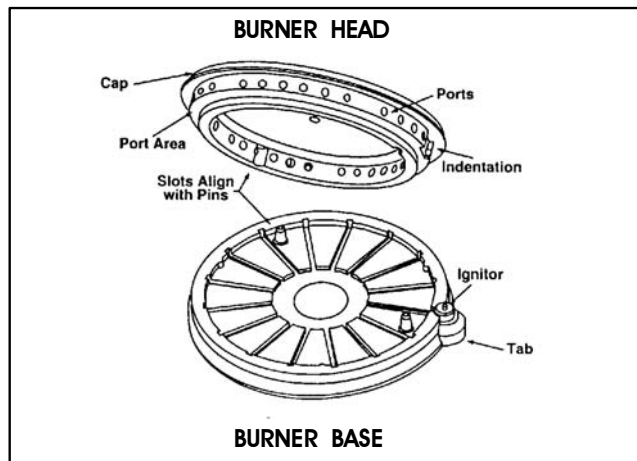

HOW TO REMOVE RANGE FOR CLEANING AND SERVICING

Follow these procedures to remove appliance for cleaning or servicing:

1. Shut off gas supply to appliance.
2. Disconnect electrical supply to appliance, if equipped.
3. Disconnect gas supply tubing to appliance.
4. Slide range forward to disengage range from the anti-tip bracket. (See page 5).
5. Reverse procedure to reinstall. If gas line has been disconnected, check for gas leaks after reconnection.

NOTE: A qualified servicer should disconnect and reconnect the gas supply.

6. To prevent range from accidentally tipping, range must be secured to the floor by sliding rear leveling leg into the anti-tip bracket.

SERVICE-PARTS INFORMATION

When your range requires service or replacement parts, contact your dealer or authorized service agency. Please give the complete model and serial numbers of the range which is located on the range model number plate.