

Service

This manual is to be used by qualified appliance technicians only. Maytag does not assume any responsibility for property damage or personal injury for improper service procedures done by an unqualified person.

This Base Manual covers general information
Refer to individual Technical Sheet
for information on specific models

This manual includes, but is
not limited to the following:

Gas Slide-In Range

JGS8750BD*
JGS8850BD*
JGS8860BD*
JGS9900BD*

Important Information

Maytag will not be responsible for personal injury or property damage from improper service procedures. Pride and workmanship go into every product to provide our customers with quality products. It is possible, however, that during its lifetime a product may require service. Products should be serviced only by a qualified service technician who is familiar with the safety procedures required in the repair and who is equipped with the proper tools, parts, testing instruments and the appropriate service information. **IT IS THE TECHNICIANS RESPONSIBILITY TO REVIEW ALL APPROPRIATE SERVICE INFORMATION BEFORE BEGINNING REPAIRS.**

Important Notices for Servicers and Consumers



WARNING

To avoid risk of severe personal injury or death, disconnect power before servicing/working on appliance to avoid electrical shock.

To locate an authorized servicer, please consult your telephone book or the dealer from whom you purchased this product. For further assistance, please contact:

Customer Service Support Center

CAIR Center

Web Site	Telephone Number
WWW.JENNAIR.COM	1-800-536-6247
WWW.MAYTAG.COM	1-800-688-9900
WWW.AMANA.COM	1-800-843-0304

CAIR Center in Canada 1-800-688-2002

Recognize Safety Symbols, Words, and Labels



DANGER

DANGER—Immediate hazards which **WILL** result in severe personal injury or death.



WARNING

WARNING—Hazards or unsafe practices which **COULD** result in severe personal injury or death.



CAUTION

CAUTION—Hazards or unsafe practices which **COULD** result in minor personal injury, product or property damage.

Table of Contents

Important Information	2	Manifold Assembly Removal	25
Important Safety Information		Control Panel Assembly Removal	25
What to Do if You Smell Gas	4	Electronic Control Replacement	25
Oven Fires	4	Burner Switch Replacement	25
Safety Practices for Servicer	4	Meat Probe Receptacle Replacement	
Servicing	4	(Select Models)	25
Receiving Oven	5	Back Panel Removal	25
Using the Oven	5	Cooling Fan Replacement	26
Baking, Broiling, and Roasting	6	Downdraft Blower Motor Removal (Select Models) .	26
Connecting Range to Gas	6	Convection Motor Removal (Select Models)	26
Electrical Requirements	6	Convection Element Replacement (Select Models) 26	
Extension Cord	6	Bake Burner and Ignitor Removal	26
Product Safety Devices	6	Broil Burner and ignitor Removal	26
General Information		Oven Sensor Replacement	26
Cooking Nomenclature	7	Regulator Removal	27
Specifications	8	Gas Valve Removal (Select Models)	27
Placement of the Oven	8	Oven Light Bulb/Oven Light Socket Replacement ..	27
Do Not Block Air Vents	8	Oven Vent/Smoke Eliminator Removal	27
Location of Model Number	8	Oven Hi-Limit Thermostat Replacement	27
Model Identification	8	Oven Door Latch Replacement	28
Service	8	Oven Door Hinge Removal	28
Parts and Accessories	8	Bottom Access Panel Removal (Select Models)	28
Extended Service Plan	8	Bottom Access Panel Disassembly	
Grounding	9	(Select Models)	28
Range Description	10	Storage Drawer Removal (Select Models)	28
Troubleshooting Procedures		Storage Drawer Track Disassembly	
Troubleshooting Chart	11	(Select Models)	28
Description of Fault Codes for EOC III	13	Storage Drawer Disassembly	28
Fault Code Chart	13	Warming Drawer Removal (Select Models)	28
Oven Sensor, Meat Probe and		Warming Drawer Element Removal	
Cooling Fan Temperature Charts	14	(Select Models)	28
Testing Procedures		Warming Drawer Hi-Limit Switch Replacement	
Component Testing Procedures	15	(Select Models)	29
Cooling Fan Temperature Chart	18	Oven Door Removal	29
Electronic Oven Control (EOC III)		Warming Drawer Track Disassembly	
Testing Procedures	19	(Select Models)	29
Relay Logic for EOC III	21	Warming Drawer Disassembly	29
“Quick Test” Mode for EOC III	22	Oven Door Disassembly	29
Oven Sensor and Meat Probe Resistances	22	Oven Door, Warming Drawer/Storage Drawer	
Description of Fault Codes for EOC III	23	and Access Panel Disassembly Illustration	30
Disassembly Procedures		Appendix A	
Removing and Replacing Range	24	Installation Instructions	A-2
Front Side Trim Removal	24	Appendix B	
Cartridge Assembly Removal (Select Models)	24	Use and Care	B-2
Maintop Assembly Removal (Select Models)	24	Appendix C: Gas Conversion Instructions	
Top Burner Assembly Removal (Select Models)	24	Model JGS8750BD*	C-2
Lower Burner Assembly Removal (Select Models) .	24	Models JGS8850BD*, JGS8860BD*	C-6
Spark Module Replacement	25	Model JGS9900BD*	C-13

Important Safety Information

As with all appliances, there are certain rules to follow for safe operation. Verify everyone who operates oven is familiar with the operations and with these precautions.

Use appliance only for its intended purpose as described. Pay close attention to the safety sections of this manual. Recognize the safety section by looking for the symbol or the word safety.

Recognize this symbol as a safety precaution.



WARNING

If the information in this manual is not followed exactly, a fire or explosion may result causing property damage, personal injury or death.

Do not store or use gasoline or other flammable vapors and liquids in the vicinity of this or any other appliance.

WHAT TO DO IF YOU SMELL GAS

- Extinguish any open flame.
- Do not try to light any appliance.
- Do not touch any electrical switch; do not use any phone in your building.
- Immediately call your gas supplier from a neighbor's phone. Follow the gas supplier's instructions.
- If you cannot reach your gas supplier, call fire department.

Installation and service must be performed by an authorized installer, service agency or gas supplier.

WARNING

To avoid risk of electrical shock, property damage, personal injury, or death, verify wiring is correct, if components were replaced. Verify proper and complete operation of unit after servicing.

WARNING

This gas appliance contains or produces a chemical or chemicals which are known to the state of California to cause cancer, birth defects, or other reproductive harm. To reduce the risk from substances in the fuel or from fuel combustion make sure this appliance is installed, operated and maintained according to the instructions in this manual.

Due to the nature of cooking, fires can occur as a result of overcooking or excessive grease. Although a fire is unlikely, if one occurs proceed as follows:

Oven Fires

1. Do not open the oven door.
2. Turn all controls to OFF.
3. As an added precaution turn off the electricity at the main circuit breaker or fuse box and the gas at the main supply valve.
4. Allow the food or grease to burn itself out in the oven.

If smoke or fire persist call the local fire department.

To avoid the risk of property damage or personal injury do not obstruct the flow of combustion or ventilation air to the oven.

To avoid the risk of electrical shock, serious personal injury or death: Make sure your oven has been properly grounded and always disconnect the electrical supply before servicing this unit.

NOTE: The maximum gas supply pressure for these models must not exceed 14 inches W.C.P.

Safety Practices for Servicer

Safe and satisfactory operation of gas ranges depends upon its design and proper installation. However, there is one more area of safety to be considered:

Servicing

Listed below are some general precautions and safety practices which should be followed in order to protect the service technician and consumer during service and after service has been completed.

1. Gas smell—Extinguish any and all open flames and open windows.
2. Turn gas off—Service range with gas turned off unless testing requires it.

Important Safety Information

3. Checking for gas leaks—Never check for leaks with any kind of open flame. Soap and water solution should be used for this purpose. Apply solution to suspected area and watch for air bubbles which indicates a leak. Correct leaks by tightening fittings, screws, connections, applying approved compound, or installing new parts.
 4. Using lights—Use a hand flashlight when servicing ranges or checking for gas leaks. Electric switches should not be operated where leaks are suspected. This will avoid creating arcing or sparks which could ignite the gas. If electric lights are already turned on, they should not be turned off.
 5. Do not smoke—Never smoke while servicing gas ranges, especially when working on piping that contains or has contained gas.
 6. Check range when service is completed—After servicing, make visual checks on electrical connection, and check for gas leaks. Inform consumer of the condition of range before leaving.
 7. Adhere to all local regulations and codes when performing service.
- Do not allow anyone to climb, stand or hang on the door. They could damage the range and cause severe personal injury.
 - Wear proper apparel. Loose fitting or hanging garments should never be worn when using oven. Flammable material could ignite if brought in contact with flame or hot oven surfaces which may cause severe burns.
 - Never use range for warming or heating a room. This may cause burns, injuries, or a fire.
 - Do not use water on grease fires.
 - Do not let grease or other flammable materials collect in or around range.
 - Do not repair or replace any part of range unless it is recommended in this manual.
 - Use only dry potholders. Moist or damp potholders used on hot surfaces may result in a burn from steam. Do not let a potholder touch the flame. Do not use a towel or a bulky cloth as a potholder.
 - Never leave range unattended while cooking. Boilovers can cause smoking and may ignite.
 - Only certain types of glass/ceramic, earthenware, or other glazed utensils are suitable for oven use. Unsuitable utensils may break due to sudden temperature change.
 - Use care when opening oven door. Let hot air or steam escape before removing or replacing food.
 - Do not heat unopened food containers in oven. Build-up of pressure may cause a container to burst and result in injury.
 - Keep range vent ducts unobstructed.
 - Place oven racks in desired location while oven is cool. If a rack must be moved while oven is hot, use a dry potholder.
 - Do not use aluminum foil to line oven bottom or racks. Aluminum foil can cause a fire will seriously affect baking results, and damage to porcelain surface's.
 - Do not touch interior surfaces of oven during or immediately after use. Do not let clothing or other flammable materials come in contact with bake or broil burners.
 - Other areas of the oven can become hot enough to cause burns, such as vent openings, window, oven door and oven racks.
 - To avoid steam burns, do not use a wet sponge or cloth to wipe up spills on hot cooking area.
 - Do not store combustible or flammable materials, such as, gasoline or other flammable vapors and liquids near or in oven.
 - Do not clean oven door gasket located on back of the door. Gasket is necessary to seal the oven and can be damaged as a result of rubbing or being moved.
 - Do not drape towels or any materials on oven door handles. These items may ignite causing a fire.

Receiving Oven

- Installer needs to show consumer location of the range gas shut-off valve and how to shut it off.
- Authorized servicer must install the range, in accordance with the Installation Instructions. Adjustments and service should be performed only by authorized servicer.
- Plug range into a 120-volt grounded outlet only. Do not remove round grounding prong from the plug. If in doubt about grounding of the home electrical system, it is consumers responsibility and obligation to have an ungrounded outlet replaced with a properly grounded three-prong outlet in accordance with the National Electrical Code. Do not use an extension cord with this appliance.
- Insure all packing materials are removed from the range before operating it, to prevent fire or smoke damage should the packing material ignite.
- Ensure range is correctly adjusted by a qualified service technician or installer for the type of gas (Natural or LP). Some ranges can be converted for use with Natural or LP gas.
- With prolonged use of a range, high floor temperatures could result. Many floor coverings will not be able to withstand this kind of use. Never install range over vinyl tile or linoleum that cannot withstand high temperatures. Never install range directly over carpeting.

Using the Oven

- Do not leave children alone or unattended where a range is hot or in operation. They could be seriously burned.

Important Safety Information



CAUTION

Do not store items of interest to children in cabinets above range. Children may climb on oven to reach these items and become seriously injured.

Baking, Broiling, and Roasting

- Do not use oven area for storage.
- Stand back from range when opening door of a hot oven. Hot air or steam can cause burns to hands, face, and eyes.
- Do not use aluminum foil anywhere in the oven. This could result in a fire hazard and damage the range.
- Use only glass cookware appropriate for use in gas ovens.
- Always remove broiler pan from oven when finished broiling. Grease left in pan can catch fire if oven is used without removing grease from the broiler pan.
- When broiling, meat that is close to the flame, may ignite. Trim any excess fat to help prevent excessive flare-ups.
- Make sure broiler pan is placed correctly to reduce any possibility of grease fires.
- Should a grease fire occur in the broiler pan, turn off oven, and keep oven door closed until fire burns out.

Connecting Range to Gas

Install manual shut-off valve in gas line for easy accessibility outside range. Be aware of the location of the shut-off valve.

Electrical Requirements

120-volt, 60 Hertz, 20 amp, individual circuit which is properly grounded, polarized and protected by a circuit breaker or fuse.

Extension Cord

Do not use extension cords with this product.

Product Safety Devices

Safety devices and features have been engineered into the product to protect consumer and servicer. Safety devices must never be removed, bypassed, or altered in such a manner as to defeat the purpose for which they were intended.

Listed below are various safety devices together with the reason each device is incorporated in the gas ranges.

Pressure Regulator

Maintains proper and steady gas pressure for operation of oven controls.

Gas Burner Orifices

Regulator must be set for the type of gas being used **Natural** or **LP**. After servicing regulator, make certain it is set properly before completing service.

Universal orifices are used on most valves. They must be adjusted for the type of gas being used **Natural** or **LP**. After servicing a valve or orifice verify it is adjusted properly before completing service.

Oven Safety Valve

Oven valve is designed to be a safety valve. Two basic designs are used in gas ranges:

Hydraulic and Electric

Both types are safety valves because they are indirectly operated by the oven thermostat, which controls a pilot flame or electric ignitor, to open and close the oven valve.

Grounded Oven Frame

Ground prong on power cord is connected to the frame, usually a green lead fastened by a screw. In addition, any part or component capable of conducting an electric current is grounded by its mounting.

If any ground wire, screw, strap, nut, etc. is removed for service, or any reason, it must be reconnected to its original position with original fastener before the appliance is put into operation again.

Failure to do so can create a possible shock hazard.

General Information

This manual provides basic instructions and suggestions for handling, installing and servicing gas ranges.

The directions, information, and warnings in this manual are developed from experience with, and careful testing of the product. If the unit is installed according to this manual, it will operate properly and will require minimal servicing. A unit in proper operating order ensures the consumer all the benefits provided by clean, modern gas cooking.

This manual contains information needed by authorized service technicians to install and service gas ranges. There may be, however, some parts which need further explanation. Refer to the Installation Instructions, Use and Care, Technical Sheets or the toll-free technical support line.

Cooking Nomenclature

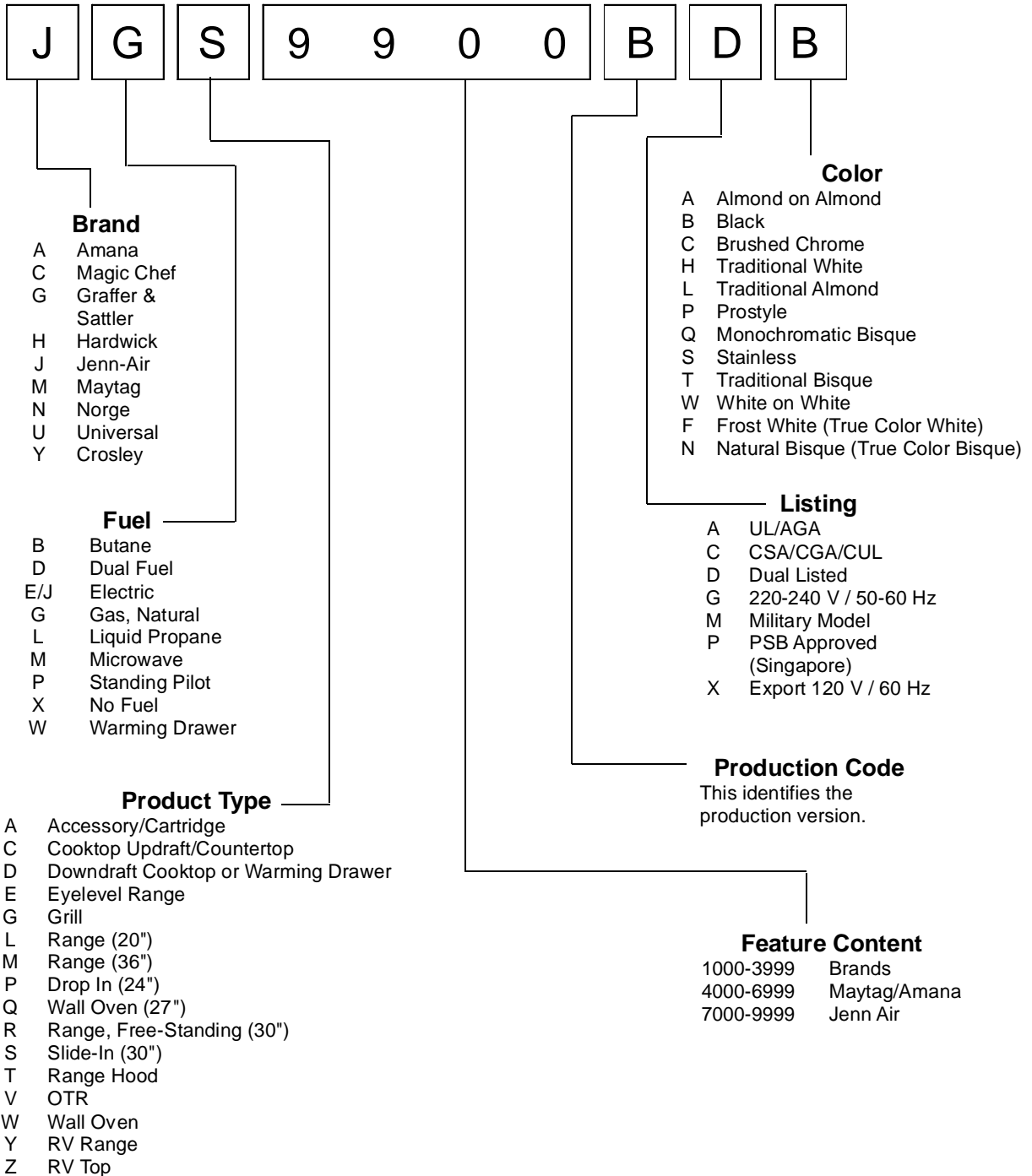

General Information

Specifications

Refer to individual Technical Sheet for specification information.

Placement of the Oven

This freestanding range must be placed in the kitchen or comparable room. All safety guidelines must be followed and free air flow around the range is essential.

Do Not Block Air Vents

All air vents must be kept clear during cooking. If air vents are covered during operation, the oven may overheat. If this occurs, a sensitive, thermal safety device automatically removes power to the oven, rendering the oven inoperable. The oven will remain in this state until it has sufficiently cooled.

Location of Model Number

To request service information or replacement parts, the service center will require the complete model, serial, and manufacturing number of your slide-in range. The number can be found on the oven chassis behind the front Access Panel. Remove the front Access Panel to view the data.

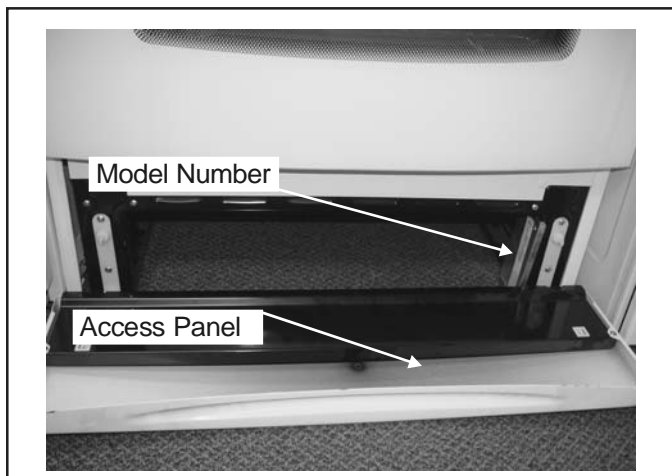

Ask a qualified electrician if you do not understand the grounding instructions or if you have questions when grounding the appliance. Keep the electrical power cord dry and keep it from getting crushed or pinched. For a permanently connected appliance: This appliance must be connected to a grounded, metallic, permanent wiring system, or an equipment grounding conductor should be run with the circuit conductors and connected to the equipment grounding terminal or lead on the appliance.

Model Identification

Complete enclosed registration card and promptly return. If registration card is missing:

- For Jenn-Air product call 1-800-536-6247 or visit the Web Site at www.jennair.com
- For Maytag product call 1-800-688-9900 or visit the Web Site at www.jennair.com
- For Amana product call 1-800-843-0304 or visit the Web Site at www.jennair.com
- For product in Canada call 1-800-688-2002.

When contacting provide product information located on rating plate. Record the following:

Model Number: _____
Manufacturing Number: _____
Serial or S/N Number: _____
Date of purchase: _____
Dealer's name and address: _____

Service

Keep a copy of sales receipt for future reference or in case warranty service is required. To locate an authorized servicer:

- For Jenn-Air/Maytag product call 1-800-462-9824 or visit the Web Sites at www.jennair.com or www.maytag.com
- For Amana product call 1-800-628-5782 or visit the Web Site at www.amana.com
- For product in Canada call 1-800-688-2002.

Warranty service must be performed by an authorized servicer. We also recommend contacting an authorized servicer, if service is required after warranty expires.

Parts and Accessories

Purchase replacement parts and accessories over the phone. To order accessories for your product call:

- For Jenn-Air product call 1-800-536-6247 or visit the Web Site at www.jennair.com
- For Maytag product call 1-800-688-9900 or visit the Web Site at www.jennair.com
- For Amana product call 1-800-843-0304 or visit the Web Site at www.jennair.com
- For product in Canada call 1-800-688-2002.

Extended Service Plan

We offer long-term service protection for this new oven.

- Asure™ Extended Service Plan is specially designed to supplement Maytag and Amana's strong warranties. These plans cover parts, labor, and travel charges. Call 1-866-232-6244 for information.
- Dependability PlusSM Extended Service Plan is specially designed to supplement Jenn-Air's strong warranty. This plan covers parts, labor, and travel charges. Call 1-800-925-2020 for information.

General Information

Grounding

NOTE: This appliance must be properly grounded, for personal safety.

Power cord on this appliance is equipped with a three-prong grounding plug. This matches standard three-prong grounding wall receptacle to prevent possibility of electric shock from this appliance.

Consumer should have wall receptacle and circuit checked by qualified electrician to verify receptacle is properly grounded.

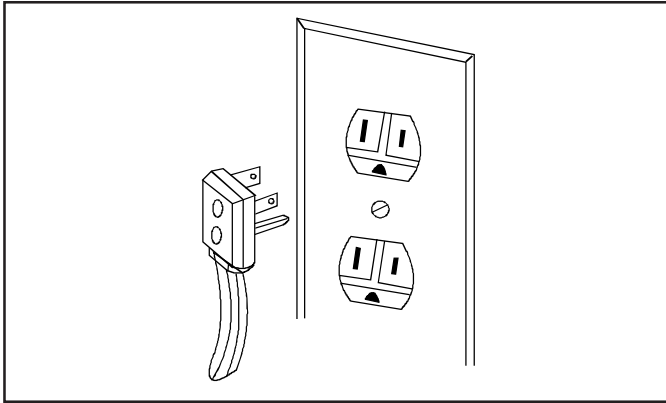

It is the consumers responsibility to replace standard two-prong wall receptacles with properly grounded three-prong wall receptacles.

DO NOT, UNDER ANY CIRCUMSTANCES, CUT OR REMOVE THE THIRD (GROUND) PRONG FROM POWER CORD.

For 15 amp circuits only, do not use an adapter on 20 amp circuit. Where local codes permit, a TEMPORARY CONNECTION may be made to a properly grounded two-prong wall receptacle by the use of a UL listed adapter (available at most hardware stores).

Larger slot on adapter must be aligned with larger slot in the wall receptacle to provide proper polarity.

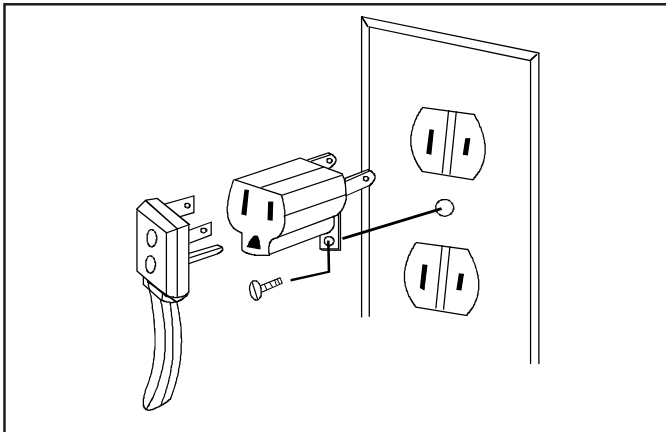

WARNING

Attaching adapter ground terminal to wall receptacle cover screw does not ground appliance unless the cover screw is metal and not insulated, and wall receptacle is grounded through the house wiring. Consumer should have circuit checked by a qualified electrician to verify receptacle is properly grounded.

When disconnecting power cord from adapter, always hold adapter with one hand. If this is not done, adapter ground terminal is very likely to break with repeated use. Should this happen, DO NOT USE appliance until a proper ground has been established.

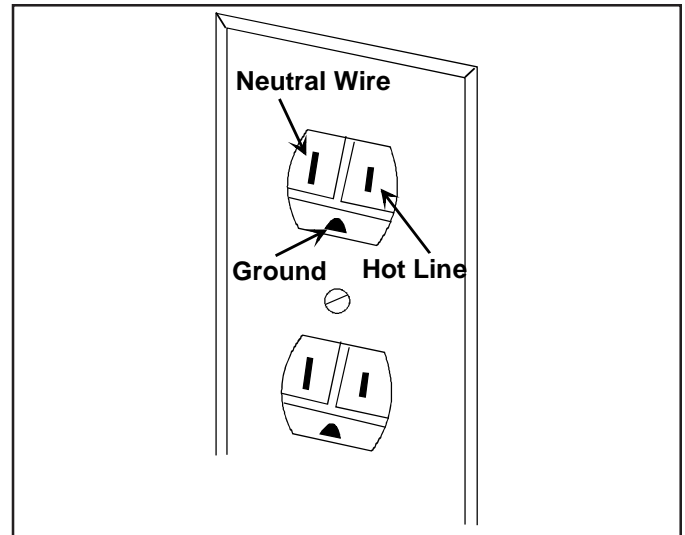

NOTE: Circuit tester can be used to verify voltage at outlet. Connect one lead to hot line and the other lead to ground. Circuit tester should light.

Range Description

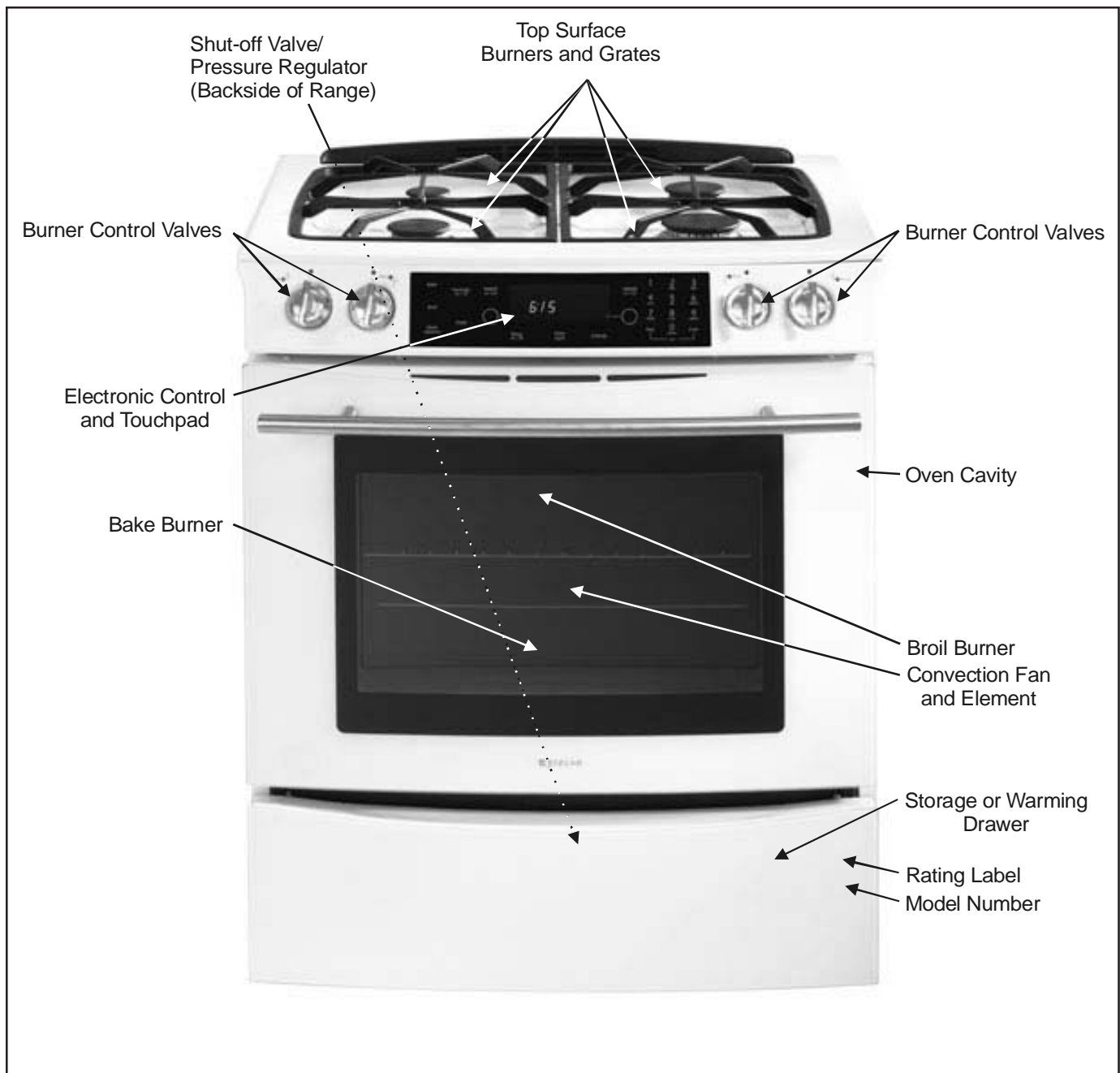

Troubleshooting Procedures



WARNING

To avoid risk of electrical shock, personal injury, or death, disconnect power and gas to range before servicing, unless testing requires power and/or gas.

Troubleshooting Chart

Problem	Possible Cause	Correction
Burners will not ignite; no spark at top burner.	Poor ground on burner cap Weak or failed spark module Low gas pressure..... Clogged burner port	<ul style="list-style-type: none"> • Clean burner cap. • Replace spark module. • Verify pressure 4" WCP for natural, 10" WCP for LP. • Clean burner cap.
Burner will not ignite. No spark to burner ignitors when burner knob is rotated to "LITE" position.	No 120 VAC to range..... Micro switch contacts not closing Faulty wiring. Bad connection at burner electrode and electrode socket .. Inoperative spark module	<ul style="list-style-type: none"> • Verify voltage at wall outlet. • Check wiring against appropriate wiring diagram. Verify all terminals and connections are correct and tight. Check micro switch contacts. • Check wiring against appropriate wiring diagram. Verify all terminals and connections are correct and tight. • Check module according to testing procedures information. • Clean electrode or burner cap. • Replace electrode.
No spark or only random spark at one ignitor.	Check for cracked ignitor/pinched wire.. Poor continuity to burner cap..... Bad ground connection or lack of continuity to ground or ignitor	<ul style="list-style-type: none"> • Replace ignitor lead or electrode. • Clean burner cap and lead. • Tighten ground connection and correct any breaks in ground path from ignitor path to unit ground path. • Replace ignitor lead.
Unit continues to spark after knob is turned to OFF position.	Shorted valve switch/harness..... Switch has slipped off the valve.....	<ul style="list-style-type: none"> • Replace switch/harness. If shorting is caused by excessive spillovers, customer education is advised. • Carefully reposition switch on valve and rotate from OFF to high, several times to verify switch is not broken.
No oven operation in bake or broil.	No voltage to control..... No voltage from control..... Loose wire connection or broken wire ..	<ul style="list-style-type: none"> • Check for 120 VAC at control. If no voltage check power source. • Check 120 VAC to ignitor, if no voltage, replace control. • Verify all connections are clean and tight, replace broken wire.
No gas flows to burner. Ignitor glows red.	Failed ignitor. Gas pressure too high..... Failed gas valve	<ul style="list-style-type: none"> • Check ignitor current draw, 3.2 – 3.6 Amps. Replace ignitor if it fails test. • Check for correct gas pressure. Natural gas pressure should be 5" WCP and LP gas pressure should be 10" WCP. • Check gas valve for continuity. • Verify all connections are clean and tight, replace broken wire.

Troubleshooting Procedures



WARNING

To avoid risk of electrical shock, personal injury, or death, disconnect power and gas to range before servicing, unless testing requires power and/or gas.

Problem	Possible Cause	Correction
Gas flows to bake/broil burner, but burner does not light.	Ignitor positioned too far from burner.... Dirt or grease in orifice or burner Insufficient gas pressure Power outage	<ul style="list-style-type: none"> • Reposition ignitor closer to bake/broil burner. • Clean orifice or burner. • Check for correct gas pressure. Natural gas pressure should be 5" WCP and LP gas pressure should be 10" WCP. • Verify power is present at unit. Verify circuit breaker is not tripped/replace fuse.
Broil burner shuts off shortly after the start of self-clean operation. Bake and broil functions operate normally.	Power outage Control Error.....	<ul style="list-style-type: none"> • Verify power is present at unit. Verify circuit breaker is not tripped. • Replace household fuse. • See "Control Systems Troubleshooting."
Fan motor does not operate.	No power to fan motor Failed fan motor or winding/frozen shaft	<ul style="list-style-type: none"> • Check for 120 VAC supplied at fan motor. If voltage is not present, check for broken/loose wiring between fan motor and relay board. If voltage is present at fan motor, go to next step. • Check motor winding for continuity. Check for a frozen motor shaft. Check for broken wiring between motor and neutral terminal block.
Oven smokes/odor first few times of usage.	Normal.....	<ul style="list-style-type: none"> • Minor smoking and/or odor is normal the first few times of oven usage.
Failure Codes.	Electronically Controlled	<ul style="list-style-type: none"> • See "Fault Code Chart."
Oven not operating.	Programming error Power outage Unit in Sabbath mode	<ul style="list-style-type: none"> • Switch range circuit breaker off for five minutes and try oven again. • Verify power is present at unit and circuit breaker is not tripped. • Replace household fuse. • Refer to Use & Care manual to remove unit from Sabbath mode.
Clock and timer not working.	Power outage Electronic Control locked	<ul style="list-style-type: none"> • Verify power is present at unit and circuit breaker is not tripped. • Replace household fuse. • Refer to Use and Care manual to unlock electronic control.
Oven light does not operate.	Failed oven lamp..... Failed wiring..... Failed light socket	<ul style="list-style-type: none"> • Check lamp and replace is necessary. • Check for broken, loose or dirty connections. • Check light socket for continuity.
Oven door will not unlock.	Oven is self-cleaning..... Oven is still hot.....	<ul style="list-style-type: none"> • Allow cycle to complete. • Will not unlock until unit has cooled to safe temperature. Do not force door open, this will void warranty. Blow cool air on latch area to quicken process.
Self-clean cycle not working.	Programming error Door lock.....	<ul style="list-style-type: none"> • Turn off circuit breaker for five minutes and try self-clean again. • Verify door lock energizes & engages.

Troubleshooting Procedures



WARNING

To avoid risk of electrical shock, personal injury, or death, disconnect power and gas to range before servicing, unless testing requires power and/or gas.

Description of Fault Codes for EOC III

Each fault code consists of 4 digits and is structured as follows:

1 st (Leftmost) Digit: Primary Failure System	2 nd Digit: Alpha-Character	3 rd Digit: Secondary Failure Mechanism	4 th Digit : Oven Cavity Number
1 – Local to Control System	d – Diagnostic Failure (measurable)		1 – Upper (Single) Oven
3 – Sensor or Meat Probe	c – Control-Related Error (not measurable)		2 – Lower Oven
4 – Input to Control System			c – Control System
9 – Door Lock			

If a fault is detected, then one of the following three messages will be scrolled on the display:

FAULT DETECTED PRESS ENTER TO TRY AGAIN. This message displays when a fault is detected while a cooking function is active. Clear by pressing the **Cancel** keypad.

FEATURE NOT AVAILABLE. This message displays when a fault is detected while entering data during initial programming and also when a locked out function is detected. Clear by pressing any key.

FAULT DETECTED DISABLE POWER TO CLEAR. This message displays when a runaway temperature condition is detected while the control is in idle mode. Press any key to clear the message, but the fault remains until the control senses a Power-On reset.

Fault Code Chart

Fault Code	Description	Component to Troubleshoot/Replace
1c1c	Shorted key.	Ensure ribbon cable is securely connected, inspect ribbon cable and connector (shorts, breakage, corrosion, etc.). If OK, replace control.
1c2c	Membrane keyboard disconnected.	Ensure ribbon cable is securely connected, inspect ribbon cable and connector (shorts, breakage, corrosion, etc.). If OK, replace control.
1c4c	Board – to – Board communication failure.	Replace control.
1c6c	EEPROM hardware fault.	Replace control.
1c7c	Control not calibrated.	Replace control.
1c8c	EEPROM CRC error – User Options.	Replace control.
1c81	EEPROM CRC error – Cook Profile.	Replace control.
1d11	Unlocked runaway temperature – 600° F	Ohm sensor and harness (see "Oven Sensor" chart). If OK, change control.
1d21	Locked runaway temperature – 950° F	Ohm sensor and harness (see "Oven Sensor" chart). If OK, change control.
3d11	Temperature sensor open.	Check connections, sensor (see "Oven Sensor" chart) and harness. If OK, replace control.
3d21	Temperature sensor shorted.	Check connections, sensor (see "Oven Sensor" chart) and harness. If OK, replace control.
3d41	Meat probe shorted.	Check probe jack and harness. If OK, check meat probe (see "Meat Probe" chart).
3d51	Meat probe not calibrated.	Check probe jack and harness. If OK, check meat probe (see "Meat Probe" chart).
4d11	Door switch not closed when locked.	Check connections, switch, harness, and motor. If OK, replace control.
4d21	No cooling fan rotation.	Check cooling fan motor and harness. If OK, replace control.
4d31	Cooling fan on when de-energized.	Check cooling fan motor and harness. If OK, replace control.
4d41	Cooling fan overspeed.	Check cooling fan motor and harness. If OK, replace control.
4d51	Door switch circuit fault.	Check connections, harness, and motor. If OK, replace control.
9d11	Latch will not lock.	Check wire connections. If OK, replace motorized door lock.
9d21	Latch will not unlock.	Check wire connections. If OK, replace motorized door lock.
9d31	Latch both locked and unlocked.	Check wire connections. If OK, replace motorized door lock.

Troubleshooting Procedures



WARNING

To avoid risk of electrical shock, personal injury, or death, disconnect power and gas to range before servicing, unless testing requires power and/or gas.

Oven Sensor, Meat Probe and Cooling Fan Temperature Charts

OVEN SENSOR	
Sensor Type: RTD 1000 Ω platinum	
Calibration: 1654 Ω (350° F / 177° C)	
Temperature F (C)	Resistance (Ohms)
100 (38)	1143
200 (94)	1350
300 (149)	1553
350 (177)	1654
400 (204)	1753
500 (260)	1949
600 (316)	2142
700 (371)	2331
800 (427)	2516
900 (483)	2697
1000 (538)	2874

MEAT PROBE	
Type: NTC Thermistor	
Calibration: 9938 Ω (150° F / 65.5° C)	
Temperature F (C)	Resistance (Ohms)
32 (0)	163300
68 (20)	62450
95 (35)	32660
122 (50)	18020
158 (70)	8760
185 (85)	5360
212 (100)	3400

COOLING FAN TEMPERATURES		
MODE	FAN ON TEMP F (C)	FAN OFF TEMP F (C)
Bake	350 (177)	300 (149)
Broil	Six (6) minute delay after cycle started	225 (107)
Clean	Six (6) minute delay after cycle started	225 (107)







Testing Procedures

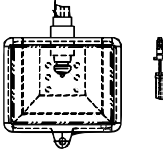
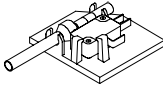
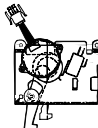

WARNING

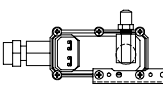
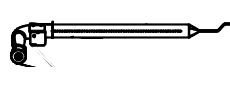
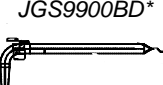
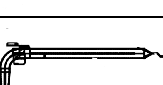
To avoid risk of electrical shock, personal injury or death; disconnect power and gas to range before servicing, unless testing requires power and/or gas.

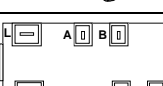
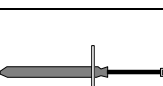
Component Testing Procedures

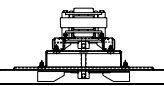







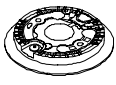
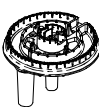

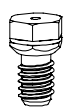

Illustration	Component	Test Procedure	Results
	Oven light & housing	Disconnect connector and test resistance of terminals Measure voltage at oven light.....	Verify bulb is properly inserted. Continuity with bulb inserted. 120 VAC, see wiring diagram for terminal identification. If voltage is not present at oven light, check wiring or light switches.
	Door plunger switch	Remove switch from unit and measure the following points: Door closed..... Door open.....	COM-NO: Continuity (closed). COM-NO: Infinity (open).
	Autolatch assembly	Disconnect wires and test for continuity per wiring diagram..... Refer to Parts Manual for correct autolatch switch associated with the correct manufacturing number.	See wiring diagram for schematic layout. Common is in neutral position unless locking or unlocking autolatch assembly.
	Door lock switch	Switch connection in the following positions: Door latch locked..... Door latch unlocked.....	COM-NO: Continuity (closed). COM-NO: Infinity (open).
	Pressure regulator	Verify gas pressure (W.C.P.)..... If on LP service verify proper gas supply conversion.	5" Natural. 10" LP/propane. Gas ON: Switch up. Gas OFF: Switch down.
	Oven valve	Verify gas supply is turned on at regulator..... Attached to pressure regulator.	Gas ON: Switch up (at regulator). Gas OFF: Switch down (at regulator).
	Broil burner	Verify gas is supplied. Orifice adjusted for Natural or LP Check for obstructions or contamination in ports	Factory set to Natural Gas. Adjust as necessary. Air shutter opening set to .281 to .343. Replace if punctured or torn.
	Bake burner	Verify gas is supplied. Orifice adjusted for Natural or LP Check for obstructions or contamination in ports	Factory set to Natural Gas. Adjust as necessary. Air shutter opening set to .281 to .343. Replace if punctured or torn.
	Bake burner	Verify gas is supplied. Orifice adjusted for Natural or LP Check for obstructions or contamination in ports	Factory set to Natural Gas. Adjust as necessary. Air shutter opening set to .469 to .531. Replace if punctured or torn.
	Ignitor	Test for voltage at terminals Test for circuit amperage..... (Ignitor may glow but not have sufficient amperage to open valve.)	120 VAC. 3.2 - 3.6 Amps. If not, replace.
	Hi-limit temperature switch	Normally closed, verify operation: Open: 249° to 271° F (121° to 133° C) .. Closed: 173° to 207° F (78° to 97° C) ...	Infinite. Continuity.
	Spark module 4 + 0	Test for voltage at terminals L and N..... Check polarity and ground.....	120 VAC. See wiring diagram.
	Temperature sensor	Measure resistance.....	Approximately 1000 Ω at room temperature 75° F (23.8° C).
	Cooling fan motor	Measure voltage..... Check motor windings to ground	120 VAC. No continuity. RPM: Approximately 1670 to 2070.

Testing Procedures



WARNING

To avoid risk of electrical shock, personal injury or death; disconnect power and gas to range before servicing, unless testing requires power and/or gas.

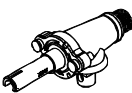
Illustration	Component	Test Procedure	Results
	Convection motor, single speed	Measure voltage Check motor windings to ground.....	120 VAC. No continuity. RPM: Approximately 900
	Convection element	Disconnect wiring to element and measure cold resistance of terminals..... Measure voltage at convection element.....	Approximately 31 Ω. 120 VAC.
JGS9900BD* 	Downdraft motor	Measure voltage Check motor windings to ground.....	120 VAC. No continuity. RPM: Approximately 1550.
	Warmer element	Disconnect wiring to element and measure cold resistance of terminals..... Measure voltage at broil element.....	Approx. 12.5 to 18 Ω. 120 VAC.
JGS8850BD*, JGS8860BD* 	Hi-limit temperature switch (Warming Drawer)	Normally closed, verify operation: Open: 135° to 145° F (57° to 63° C)..... Closed: 114° to 126° F (46° to 52° C)....	Infinite. Continuity.
JGS8850BD*, JGS8860BD* 	Hi-limit temperature switch (Warming Drawer)	Normally closed, verify operation: Open: 95° to 105° F (35° to 41° C)..... Closed: 79° to 91° F (26° to 33° C).....	Infinite. Continuity.
	Spark switch	Test for voltage at terminals..... Disconnect wiring and check for continuity in LITE position.....	120 VAC. Continuity in LITE position.
	Spark ignition electrode	Test for resistance of spark lead..... Test ignitor to chassis.....	Continuity. No continuity from ignitor to chassis.
	Top surface burner 5 K btu, 9.2 K btu 16 K btu	Verify gas is supplied..... Verify burner cap is positioned correctly...	Gas supplied. Check for obstructions in burner ports.
	Top surface, dual ring burner 15 K btu Inner: 3 K btu Outer: 12 K btu	Verify gas is supplied..... Verify burner cap is positioned correctly...	Gas supplied. Check for obstructions in burner ports.
	Top surface, burner cap 5 K btu, 9.2 K btu 16 K btu	Verify cap is positioned correctly.....	Check for obstructions in burner ports.
	Top surface, burner cap, dual ring (inner and outer rings)	Verify cap is positioned correctly.....	Check for obstructions in burner ports.
	Orifice	Check for debris.....	Clean as needed.
	Orifice holder 5 K btu, 9.2 K btu 16 K btu	Verify gas pressure..... Check orifice for debris.....	5" Natural. 10" LP/propane. Clean as needed.
	Burner valve, push-to-turn, 270° 5 K btu, 9.2 K btu 16 K btu	Verify gas is supplied..... Orifice adjusted for Natural or LP. Adjust set screw for simmer control.	Gas supplied.

Testing Procedures



WARNING

To avoid risk of electrical shock, personal injury or death; disconnect power and gas to range before servicing, unless testing requires power and/or gas.

Electronic Oven Control (EOC) III Testing Procedures

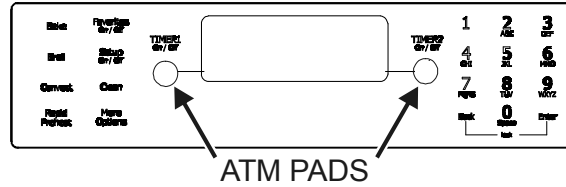

ELECTRONIC OVEN CONTROL (EOC) III TESTING/PROGRAMMING PROCEDURES		
Feature	Access Procedure	Modification Procedure
Control Reset Resets control to factory default values.	Press the Setup pad, then press the right ATM pad until SERVICE displays. Press the left ATM pad to select SERVICE menu options.	Press and hold the Back and Enter pads for 5 seconds to enter SERVICE menu options. Press the right ATM pad to scroll to CONTROL RESET. Press the left ATM pad to select CONTROL RESET, then press the left ATM pad again to reset the control logic. Press Setup to exit.
Oven Temperature Adjustment Determines oven cavity offset temperature (range from -35° F to +35° F, or -21° C to +21° C).	Press the Setup pad, then press the right ATM pad until TEMP ADJUST displays. Press the left ATM pad to select oven TEMP ADJUSTMENT settings.	Enter the offset temperature setting desired using the digits pads. Press the right ATM pad for + temperature adjustment, or the left ATM pad for – temperature adjustment. Press 0 to reset control back to no temperature adjustment. Wait 3 seconds for the control to accept the request. Press Setup to exit.
Sabbath Mode Based on the Jewish guidelines for Sabbath/Holiday requirements.	Press the Setup pad, then press the right ATM pad until SABBATH displays. Press the left ATM pad to select SABBATH settings.	Press the left ATM pad to select Manual Sabbath mode, or the right ATM pad to select Auto Sabbath mode. Press the left ATM pad to turn on Sabbath mode, or the right ATM pad to turn off Sabbath mode. Press Setup to exit.
Time Options Determines control time, day of week, 12/24 hour clock.	Press the Setup pad, then the left ATM pad to select TIME OPTIONS.	Press the right ATM pad to scroll to the desired function to modify.
Time Set Determines time of day to display on control.	Press the Setup pad, then the left ATM pad, then the left ATM pad again to set the time of day clock.	Enter the correct time using the digits pads and press Enter . Press the left ATM pad to select AM or the right ATM pad to select PM. Press Setup to exit.
Day of Week Determines day of week (Monday thru Sunday) to display on control.	Press the Setup pad, then the left ATM pad, then press the right ATM pad until DAY displays. Press the left ATM pad to set the day of the week.	Press the right ATM pad until the correct day displays, then press the left ATM pad to select. Press Setup to exit.
12/24-Hour Clock Display Determines 12-hour or 24-hour clock display on control.	Press the Setup pad, then the left ATM pad, then press the right ATM pad until 12/24HR displays. Press the left ATM pad to select 12/24 HR clock.	Press the left ATM pad to select 12-hour clock, or the right ATM pad to select 24-hour clock. Press Setup to exit.
Clock & Day Display Disable Determines if time of day and day of week will display on control.	Press the Setup pad, then press the right ATM pad until DISABLE displays. Press the left ATM pad to select DISABLE settings.	Press the left ATM pad to select TIME, or the right ATM pad to scroll to DAY, press the left ATM pad. Press the left ATM pad to enable display or the right ATM pad to disable display. Press Setup to exit.
Language Display Determines language display on control (English, French, Spanish).	Press the Setup pad, then press the right ATM pad until LANGUAGE displays. Press the left ATM pad to set LANGUAGE settings.	Press the right ATM pad until the desired language displays (English, French, Spanish). Press the left ATM pad. Press Setup to exit.
C/F (Celsius/Fahrenheit) Display Determines temperature display on control (C or F).	Press the Setup pad, then press the right ATM pad until C/F displays. Press the left ATM pad to select C/F settings.	Press the left ATM pad to select Celsius or the right ATM pad to select Fahrenheit. Press Setup to exit.
Auto Convection When enabled, reduces the Convection Bake and Pastry temperatures by 25° F (-3.9° C).	Press the Setup pad, then press the right ATM pad until AUTO CONVECT displays. Press the left ATM pad to select AUTO CONVECT settings.	Press the left ATM pad to turn on auto convect, or the right ATM pad to turn off auto convect. Press Setup to exit.
208/240 V Setting Determines range operating voltage (208 or 240 VAC).	Press the Setup pad, then press the right ATM pad until 208/240 displays. Press the left ATM pad to select 208/240 V settings.	Press the left ATM pad to select 208 VAC, or the right ATM pad to select 240 VAC. Press Setup to exit.

Testing Procedures



WARNING

To avoid risk of electrical shock, personal injury or death; disconnect power and gas to range before servicing, unless testing requires power and/or gas.

Feature	Access Procedure	Modification Procedure
Tone Options Determines cook tones, timer tones and volume settings.	Press the Setup pad, then press the right ATM pad until TONES displays. Press the left ATM pad to select TONES options.	Press the right ATM pad to scroll to the desired tone to modify. Press Setup to exit.
12-Hour Shutoff Disables 12-hour shutoff, allowing the oven to operate indefinitely.	Press the Setup pad, then press the right ATM pad until 12HR SHUTOFF displays. Press the left ATM pad to select 12-HOUR SHUTOFF settings.	Press the left ATM pad to turn on 12-hour shutoff, or the right ATM pad to turn off 12-hour shutoff. Press Setup to exit.
Cook Tones Determines the number and duration of cook time reminder chimes.	Press the Setup pad, then press the right ATM pad until TONES displays. Press the left ATM pad. Press the left ATM pad again to select COOK TONES settings.	Press the left ATM pad to select 1 – 30 (1 chime every 30 seconds after the initial 4 chimes), or press the right ATM pad to scroll to 1 – 60 (1 chime every 60 seconds after the initial 4 chimes) or 1 BEEP (no additional chimes after the initial 4 chimes). Press the left ATM pad to select the desired setting. Press Setup to exit.
Timers Tones Determines the number and duration of timer reminder chimes.	Press the Setup pad, then press the right ATM pad until TONES displays. Press the left ATM pad. Press the right ATM pad to scroll to TIMERS TONES. Press the left ATM pad to select TIMERS TONES settings.	Press the left ATM pad to select 2 – 30, or 2 chimes every 30 seconds for up to 5 minutes (after the initial chime), or press the right ATM pad to scroll to 2 – 60, or 2 chimes every 60 seconds for up to 30 minutes (after the initial chime), or 1 BEEP (no additional chimes after the initial chime). Press the left ATM pad to select the desired setting. Press Setup to exit.
Volume Determines volumes of cook and timer tones.	Press the Setup pad, then press the right ATM pad until TONES displays. Press the left ATM pad to select VOLUME settings.	Press the right ATM pad until VOLUME displays. Press the left ATM pad. Press the left ATM pad to select HIGH, or the right ATM pad to scroll to MEDIUM or LOW. Press the left ATM pad to select. Press Setup to exit.
Energy Saver Mode Enables a 1 watt standby feature. If no pad is pressed within 5 minutes, the control enters into a sleep mode.	Press the Setup pad, then press the right ATM pad until ENERGY SAVER displays. Press the left ATM pad to select ENERGY SAVER mode settings.	Press the left ATM pad to enter the energy saver mode or the right ATM pad to exit the energy saver mode.
Demo Mode Enables a 1 watt standby feature. If no pad is pressed within 5 minutes, the control enters into a sleep mode.	Press the Setup pad, then press the right ATM pad until DEMO displays. Press the left ATM pad to select DEMO mode settings.	Press the left ATM pad to enable the DEMO mode or the right ATM pad to exit the DEMO mode. Once the DEMO mode begins, press any key to exit. Press Setup to exit, also.
Service Mode Enables access to service menus.	Press the Setup pad, then press the right ATM pad until SERVICE displays. Press the left ATM pad to select SERVICE menu options.	Press and hold the Back and Enter pads for 5 seconds to enter SERVICE menu options. Press Setup to exit.
Test Access Enables access to service menus.	Press the Setup pad, then press the right ATM pad until SERVICE displays. Press the left ATM pad to select SERVICE menu options.	Press and hold the Back and Enter pads for 5 seconds to enter SERVICE menu options. Press the right ATM pad to scroll to TEST menu. Press the left ATM pad to select TEST options. Press Setup to exit.
Faults Access Displays the 10 most recent faults produced by the controller.	Press the Setup pad, then press the right ATM pad until SERVICE displays. Press the left ATM pad to select SERVICE menu options.	Press and hold the Back and Enter pads for 5 seconds to enter SERVICE menu options. Press the right ATM pad to scroll to the FAULTS menu. Press the left ATM pad to select FAULTS options. Press Setup to exit.
Software Versions Access Displays the software and EEPROM revision levels.	Press the Setup pad, then press the right ATM pad until SERVICE displays. Press the left ATM pad to select SERVICE menu options.	Press and hold the Back and Enter pads for 5 seconds to enter SERVICE menu options. Press the right ATM pad to scroll to the VERSIONS menu. Press the left ATM pad to view. Press Setup to exit.
Display Test Illuminates all lamps on the control.	Press the Setup pad, then press the right ATM pad until SERVICE displays. Press the left ATM pad to select SERVICE menu options.	Press and hold the Back and Enter pads for 5 seconds to enter SERVICE menu options. Press the right ATM pad to scroll to DISPLAY TEST. Press the left ATM pad. Press Setup to exit.
Control Lockout Disables the touch keypad control and locks the oven cavity door.	Press the Back and Setup pads simultaneously for 5 seconds to lock.	Press the Back and Setup pads simultaneously for 5 seconds to unlock.

Testing Procedures



WARNING

To avoid risk of electrical shock, personal injury or death; disconnect power and gas to range before servicing, unless testing requires power and/or gas.

Relay Logic for EOC III

NOTE: Subsequent changes implemented after the release of this technical sheet may have altered the parameters identified in this chart.

INDEX						
X - OFF O - ON ■ - CYCLING ◇ - ON OR OFF (DETERMINED BY USER INPUT)						
COOKING MODE	BAKE ELEMENT	BROIL ELEMENT	CONVECT ELEMENT	CONVECT FAN	WARMING DRAWER	OVEN LIGHT
IDLE	X	X	X	X	X	◇
BAKE RAPID PREHEAT	O	X	X	X	X	◇
BAKE PREHEAT	O	X	X	X	X	◇
BAKE	■	X	X	X	X	◇
HIGH BROIL PREHEAT	X	O	X	X	X	◇
HIGH BROIL	X	■	X	X	X	◇
LOW BROIL PREHEAT	X	O	X	X	X	◇
LOW BROIL	X	■	X	X	X	◇
CLEAN PREHEAT	■	■	■	X	X	X
CLEAN	■	■	■	X	X	X
KEEP WARM PREHEAT	O	X	X	X	X	◇
KEEP WARM	■	X	X	X	X	◇
WARMING DRAWER HIGH	X	X	X	X	O	◇
WARMING DRAWER LOW	X	X	X	X	O	◇
CONVECT ROAST PREHEAT	X	X	O	X	X	◇
CONVECT ROAST	X	X	■	O*	X	◇
CONVECT BAKE RAPID PREHEAT	X	X	O	X	X	◇
CONVECT BAKE PREHEAT	X	X	O	X	X	◇
CONVECT BAKE	X	X	■	X	X	◇
CONVECT PASTRY RAPID PREHEAT	X	X	O	O*	X	◇
CONVECT PASTRY PREHEAT	X	X	O	O*	X	◇
CONVECT PASTRY	X	X	■	O*	X	◇
THAW-SERVE	■	■	X	X	X	◇
DRYING PREHEAT	X	X	O	X	X	◇
DRYING	X	X	■	X	X	◇
RAPID PROOFING	X	X	O	O	X	◇
STANDARD PROOFING	X	X	O	X	X	◇

*Convection fan stops when oven door is opened.

Testing Procedures



WARNING

To avoid risk of electrical shock, personal injury or death; disconnect power and gas to range before servicing, unless testing requires power and/or gas.

"Quick Test" Mode for EOC III

Follow the procedure below to perform the EOC III quick test. Once the control is in the quick test mode, any relay may be activated in any sequence. The test mode will be exited after 10 minutes of inactivity (no pads pressed within 10 minutes).

1. Press the **Setup** pad, then press the right **ATM** pad.
2. Press the left **ATM** pad, then press and hold **Back** and **Enter** pads for 5 seconds to enter SERVICE menu options.
3. Press the right **ATM** pad to scroll to the TEST menu.
4. Press the left **ATM** pad to select TEST options.
5. Press the left **ATM** pad again to enter the "Quick Test" mode.
6. Press each of the following pads indicated in the table below.
7. Press **Cancel** or **Setup** pads to exit.

NOTE: Press and hold the applicable pad to activate the associated response.
Release the applicable pad to deactivate the associated response.

The control automatically enters the engineering mode so visual feedback of relay operations is available on the control display. Any time a load is activated, the cooling fan is activated. When the load is deactivated, the cooling fan is also deactivated.

Display will indicate the following:

Pad	Response
BAKE.....	Bake relay activated.
BROIL	Broil relay activated.
CONVECT.....	Convection Bake and Cooling Fan relays activated.
OVEN LIGHT	Oven light relay activated.
RAPID PREHEAT	Convection Fan (HIGH/LOW) activated.
WARMING ZONE	Warming Zone relay activated.
VENT (DOWNDRAFT) FAN	Vent Fan relay activated.
CLEAN	Motorized Door Lock relay activated.
SETUP	1 Second Beep.
FAN.....	Downdraft Fan (HIGH/LOW) relay activated.
WARMING DRAWER	Warming Drawer (HIGH/LOW) relay activated.

Oven Sensor and Meat Probe Resistances

OVEN SENSOR	
Sensor Type: RTD 1000 Ω platinum	
Calibration: 1654 Ω (350° F/177° C)	
Temperature F (C)	Resistance (Ohms)
200 (94)	1350
350 (177)	1654
550 (287)	2047
900 (483)	2697

MEAT PROBE	
Type: NTC Thermistor	
Calibration: 9938 Ω (150° F/65.5° C)	
Temperature F (C)	Resistance (Ohms)
32 (0)	163300
68 (20)	62450
95 (35)	32660
122 (50)	18020
158 (70)	8760
185 (85)	5360
212 (100)	3400

Testing Procedures



WARNING

To avoid risk of electrical shock, personal injury or death; disconnect power and gas to range before servicing, unless testing requires power and/or gas.

Description of Fault Codes for EOC III

Each fault code consists of 4 digits and is structured as follows:

1 st (Leftmost) Digit: Primary Failure System	2 nd Digit: Alpha-Character	3 rd Digit: Secondary Failure Mechanism	4 th Digit : Oven Cavity Number
1 – Local to Control System	d – Diagnostic Failure (measurable)		1 – Upper (Single) Oven
3 – Sensor or Meat Probe	c – Control-Related Error (not measurable)		2 – Lower Oven
4 – Input to Control System			c – Control System
9 – Door Lock			

If a fault is detected, then one of the following three messages will be scrolled on the display:

FAULT DETECTED PRESS ENTER TO TRY AGAIN. This message displays when a fault is detected while a cooking function is active. Clear by pressing the **Cancel** keypad.

FEATURE NOT AVAILABLE. This message displays when a fault is detected while entering data during initial programming and also when a locked out function is detected. Clear by pressing any key.

FAULT DETECTED DISABLE POWER TO CLEAR. This message displays when a runaway temperature condition is detected while the control is in idle mode. Press any key to clear the message, but the fault remains until the control senses a Power-On reset.

Fault Code	Description	Component to Troubleshoot/Replace
1c1c	Shorted key.	Ensure ribbon cable is securely connected, inspect ribbon cable and connector (shorts, breakage, corrosion, etc.). If OK, replace control.
1c2c	Membrane keyboard disconnected.	Ensure ribbon cable is securely connected, inspect ribbon cable and connector (shorts, breakage, corrosion, etc.). If OK, replace control.
1c4c	Board – to – Board communication failure.	Replace control.
1c6c	EEPROM hardware fault.	Replace control.
1c7c	Control not calibrated.	Replace control.
1c8c	EEPROM CRC error – User Options.	Replace control.
1c81	EEPROM CRC error – Cook Profile.	Replace control.
1d11	Unlocked runaway temperature – 600°	Ohm sensor and harness (see "Oven Sensor" chart). If OK, change control.
1d21	Locked runaway temperature – 950°	Ohm sensor and harness (see "Oven Sensor" chart). If OK, change control.
3d11	Temperature sensor open.	Check connections, sensor (see "Oven Sensor" chart) and harness. If OK, replace control.
3d21	Temperature sensor shorted.	Check connections, sensor (see "Oven Sensor" chart) and harness. If OK, replace control.
3d41	Meat probe shorted.	Check probe jack and harness. If OK, check meat probe (see "Meat Probe" chart).
3d51	Meat probe not calibrated.	Check probe jack and harness. If OK, check meat probe (see "Meat Probe" chart).
4d11	Door switch not closed when locked.	Check connections, switch, harness, and motor. If OK, replace control.
4d21	No cooling fan rotation.	Check cooling fan motor and harness. If OK, replace control.
4d31	Cooling fan on when de-energized.	Check cooling fan motor and harness. If OK, replace control.
4d41	Cooling fan overspeed.	Check cooling fan motor and harness. If OK, replace control.
4d51	Door switch circuit fault.	Check connections, harness, and motor. If OK, replace control.
9d11	Latch will not lock.	Check wire connections. If OK, replace motorized door lock.
9d21	Latch will not unlock.	Check wire connections. If OK, replace motorized door lock.
9d31	Latch both locked and unlocked.	Check wire connections. If OK, replace motorized door lock.

Disassembly Procedures



CAUTION

To avoid risk of electrical shock, personal injury or death; disconnect power and gas before servicing, unless testing requires power and/or gas.

Removing and Replacing Range

1. Turn off power and remove gas supply from unit.
2. Slide range forward from installation position.
3. Unplug power cord and disconnect gas line from unit.
4. Disconnect downdraft blower motor and remove flex ducting to the blower and range (select models).

NOTE: To avoid countertop damage, do not move range forward until range has been raised enough to clear all cabinetry.

5. Pull the range forward out of the cabinet opening.
6. Disconnect or unplug the power cord leading from unit to fuse box or junction box depending on unit.
7. Replace the oven using the installation instructions and anti-tip bracket(s).

Front Side Trim Removal

1. Remove power from unit.
2. Slide unit out far enough to access side trim.
3. Remove screws securing front side trim piece(s) to oven chassis (left and right trim pieces).
4. Gently grasp trim piece with both hands, pull forward and roll trim piece off retainer clips.
5. Reverse procedure to reinstall front side trim piece(s).

Cartridge Assembly Removal (Select Models)

Cooktop cartridges are installed on the left side of the range cooktop.

1. Remove power from unit.
2. Lift up on the tab (located on the cartridge) until top of cartridge clears the opening on the range by 2 inches.

NOTE: Lifting the cartridge too high while still engaged in the receptacle could damage the terminal plug.

3. Hold cartridge by the sides and slide away from terminal receptacle.
4. Lift cartridge out when fully unplugged.

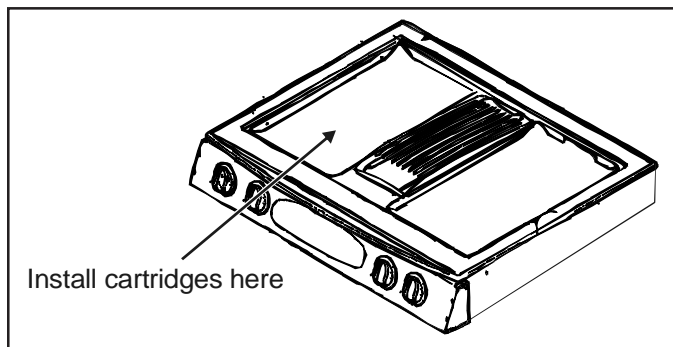

Maintop Assembly Removal (Select Models)

1. Remove power from unit.
2. Remove range from installation position, see "Removing and Replacing Range" procedure.
3. Remove front side trim, see "Front Side Trim Removal" procedure.
4. Remove air grill, grill grates, filter, aeration pan and cartridges (cartridge models).
5. Remove cartridge receptacles and grill pans (cartridge models).
6. Remove screws from plenum area at front of main top cartridge opening (cartridge models).
7. Remove screws securing top burner assembly to lower burner assembly.
8. Label and disconnect wire terminals to ignitors.
9. Remove perimeter screws securing main top to chassis.
10. Gently lift main top away from chassis.
11. Reverse procedure to reinstall maintop assembly.

Top Burner Assembly Removal (Select Models)

1. Disconnect power before servicing.
2. Remove screws securing burner top assembly to lower assembly.
3. Label and remove wire terminals to ignitor.
4. Reverse procedures to reassemble.

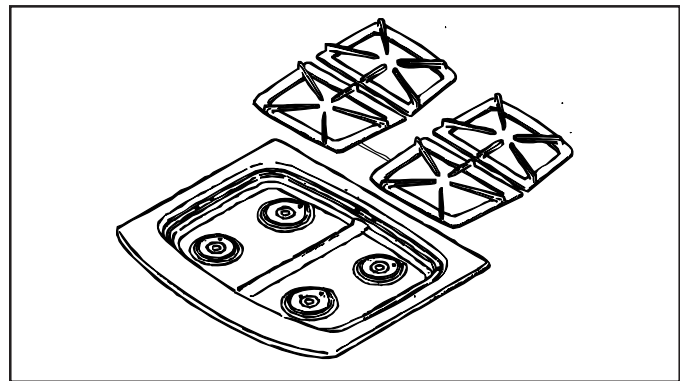

Lower Burner Assembly Removal (Select Models)

1. Remove top burner, see "Top Burner Assembly Removal (Select Models)" procedure.
2. Disconnect tubing from lower assembly.
3. Reverse procedures to reassemble.

NOTE: Perform gas leak test.

Disassembly Procedures



CAUTION

To avoid risk of electrical shock, personal injury or death; disconnect power and gas before servicing, unless testing requires power and/or gas.

Spark Module Replacement

1. Remove unit from installation position, see "Removing and Replacing Range" procedure.
2. Remove screws securing rear access panel.
3. Disconnect and label wire connections from the spark module.
4. Remove screws securing spark module to unit chassis.
5. Replace and reverse procedure to reassemble.

Manifold Assembly Removal

1. Remove maintop, see "Maintop Assembly Removal" procedure.

NOTE: If replacing manifold only, skip step 2.

2. Loosen and disconnect fittings securing surface burner tubing to burner assembly and manifold.
3. Remove bolt(s) securing surface valve(s) to manifold.
4. Remove bolt securing shut-off valve from manifold.
5. Disconnect tubing from manifold to the regulator.
6. Reverse procedures to reassemble.

NOTE: Perform gas leak test.

Control Panel Assembly Removal

1. Remove power from unit.
2. Remove burner switch control knobs.
3. Remove front screws securing control panel to chassis.
4. Remove screws located on the left and right sides of the control panel.
5. Grasp control panel on the far left and right sides and gently pull the control panel out and down.

NOTE: The electronic control located in the control panel is a sensitive item, handle gently.

6. Label and disconnect wire terminals.
7. Remove infinite switch control knobs, infinite switches, indicator lights, rocker switches, and electronic control/clock (as necessary) and transfer to the new control panel.
8. Reverse procedure to reinstall control panel.

Electronic Control Replacement

1. Remove control panel, see "Control Panel Assembly Replacement" procedure, steps 1 through 5.
2. Remove screws securing electronic control bracket to control panel.
3. Label and disconnect terminal wiring from electronic control.
4. Slide electronic control down and out of bracket, applying slight outward pressure to the inside edges of the electronic control bracket.
5. Reverse procedure to reinstall electronic control.

Burner Switch Replacement

1. Remove control panel, see "Control Panel Assembly Removal" procedure.
2. Disengage burner switch from burner valve and remove switch from valve.
3. Reverse procedure to reinstall burner switch.

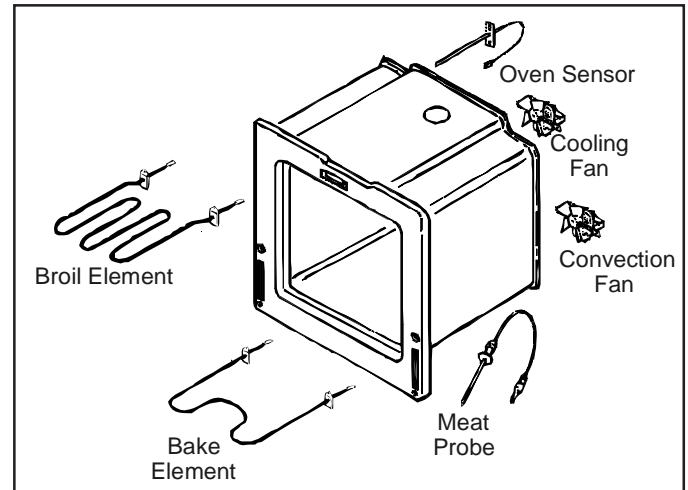

Meat Probe Receptacle Replacement (Select Models)

1. Remove power from unit.
2. Remove range from installation position, see "Removing and Replacing Range" procedure.
3. Remove front side trim, see "Front Side Trim Removal" procedure.
4. Remove screws securing side panel to chassis and main top.
5. Open oven door and remove nut securing meat probe receptacle to oven cavity.
6. Label and disconnect wire terminals from receptacle.
7. Gently slide meat probe receptacle through oven cavity.
8. Reverse procedure to reinstall meat probe receptacle.

Back Panel Removal

1. Remove power from unit.
2. Remove range from installation position, see "Removing and Replacing Range" procedure.
3. Remove screws securing back panel to unit.
4. Slide back panel up and out to remove.
5. Reverse procedure to reinstall back panel.

Disassembly Procedures



CAUTION

To avoid risk of electrical shock, personal injury or death; disconnect power and gas before servicing, unless testing requires power and/or gas.

Cooling Fan Replacement

1. Remove power from unit.
2. Remove range from installation position, see "Removing and Replacing Range" procedure.
3. Remove back panel, see "Back Panel Removal" procedure.
4. Label and disconnect wire terminals from cooling fan.
5. Remove screws securing fan to range chassis.
6. Reverse procedure to reinstall cooling fan.

Downdraft Blower Motor Removal (Select Models)

1. Remove power from unit.
2. Remove bottom access panel, see "Bottom Access Panel Removal" procedure.
3. Disconnect ducting to allow for downdraft blower motor removal.
4. Label and disconnect wire terminals.
5. Remove screws securing motor assembly.
6. Reverse procedure to reinstall downdraft blower motor (select models).

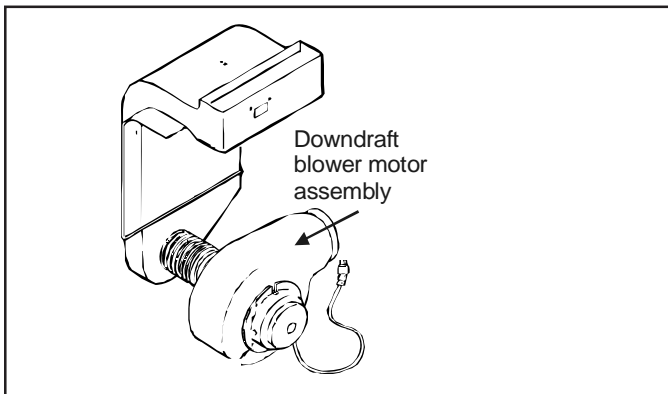

Convection Motor Removal (Select Models)

1. Remove power from unit.
2. Open oven door and remove rack(s).
3. Remove screws securing convection element and fan cover (on rear wall of oven cavity).
4. Remove screw securing fan blade to fan motor shaft.
5. Remove screws securing fan motor to cavity wall.
6. Slide motor into oven cavity.
7. Label and disconnect wire terminals from motor.
8. Reverse procedure to reinstall convection motor.

Convection Element Replacement (Select Models)

1. Remove power from unit.
2. Open oven door and remove rack(s).

3. Remove screws securing convection element and fan cover (on rear wall of oven cavity).
4. Remove screw securing convection element to rear oven cavity wall.
5. Label and disconnect wire terminals from element.
6. Reverse procedure to reinstall convection element.

Bake Burner and Ignitor Removal

1. Turn off electrical power and gas to the range.
2. Disconnect gas and power from unit.
3. Remove oven door, racks and oven bottom.
4. Remove screws securing bottom bake cover.
5. Raise the back of the bake burner cover and slide cover back to release the front edge of cover and lift out of oven cavity.
6. Remove screws securing bake burner assembly to the oven chassis.
7. Maneuver bake burner from the burner orifice and out of the slotted location.
8. Pull forward on assembly to allow the ignitor terminal plug to pass through the back of the oven cavity.
9. Disconnect terminal plug and remove assembly from the oven cavity.
10. Remove screws securing ignitor to bake burner.
11. Replace and reassemble in reverse order.

Broil Burner and Ignitor Removal

1. Turn off electrical power and gas to the range.
2. Disconnect gas and power from unit.
3. Remove oven door and racks.
4. Remove screws securing ignitor wire plate cover to back of the oven cavity.
5. Maneuver ignitor wire terminal plug through the rear of the oven cavity.
6. Disconnect ignitor wire terminal plug.
7. Remove screws securing broiler to oven cavity.
8. Carefully maneuver burner off of the broiler orifice spud and remove from cavity.
9. Remove screws securing ignitor to broiler.
10. Remove wing nut securing flame spreader to broiler.
11. Replace and reassemble in reverse order.

Oven Sensor Replacement

1. Remove power from unit.
2. Open oven door and remove screws securing sensor to oven cavity.

NOTE: Gently pull wiring through cavity wall.

3. Label and disconnect wire terminals.
4. Reverse procedure to reinstall sensor.

NOTE: Verify sensor wires are pushed through the insulation.

Disassembly Procedures



To avoid risk of electrical shock, personal injury or death; disconnect power and gas before servicing, unless testing requires power and/or gas.

Regulator Removal

1. Disconnect power before servicing.
2. Remove range from installation position, see "Removing and Replacing Range" procedure.
3. Disconnect tubing from regulator.
4. Remove screws securing bracket to back of unit.
5. Remove screws securing regulator to support bracket.
6. Reverse procedures to reassemble.

NOTE: When reconnecting supply line to regulator, use pipe dope compound to seal the connection.

NOTE: Perform gas leak test.

Gas Valve Removal (Select Models)

NOTE: Removal of range from installation position is required.

1. Disconnect power before servicing.
2. Remove range from installation position, see "Removing and Replacing Range" procedure.
3. Remove screws securing bottom rear access panel to chassis.
4. Remove screws securing top rear access panel to chassis.
5. Disconnect tubing from gas valve.
6. Disconnect and label wire terminals from gas valve.
7. Remove screws securing gas valve to chassis.
8. Reverse procedures to reassemble.

NOTE: Perform gas leak test.

Oven Light Bulb/Oven Light Socket Replacement

The light automatically illuminates when the door is opened. The light will not operate during a clean cycle.

1. Remove power from unit.
2. Open oven door and locate oven light.
3. Grasp lens cover and pull outward on one side to gain access to the bulb.
4. Carefully remove old bulb by lifting bulb straight out of base.
5. When installing the new bulb, place cover over socket so the cut-out in the glass cover aligns with the base on the socket.

NOTE: To avoid damaging the new bulb and decreasing life of the bulb, do not touch new bulb with bare hands or fingers.

Hold with a cloth or paper towel.

NOTE: Proceed with the following steps for oven light socket removal.

6. Remove power to unit.

7. Remove screw securing light socket to oven cavity.
8. Label and disconnect wire terminals from light socket.
9. Reverse procedure to reinstall light socket.

NOTE: Reposition fiberglass insulation around light socket to eliminate the possibility of any heat related problems.

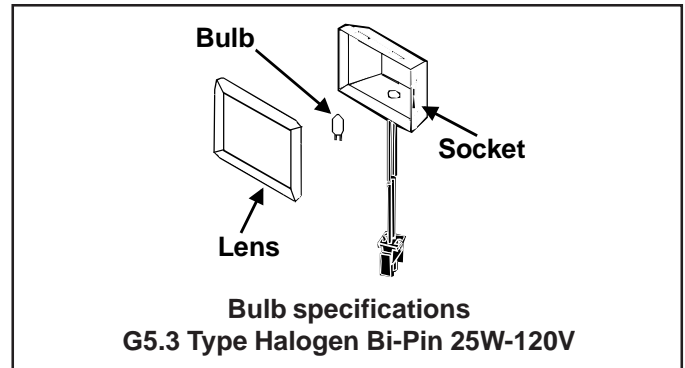

Oven Vent/Smoke Eliminator Removal (Select Models)

1. Remove power from unit.
2. Locate tabs on bottom of smoke eliminator and turn counterclockwise to release locking ears.
3. Gently pull smoke eliminator down and align locking ears with notches in oven cavity to remove.
4. Reverse procedure to reinstall smoke eliminator.

Oven Hi-Limit Thermostat Replacement

1. Remove maintop assembly, see "Maintop Assembly Removal" procedure.
2. Remove screws securing hi-limit thermostat to oven chassis.
3. Label and remove wire terminals.
4. Reverse procedure to reinstall hi-limit thermostat.

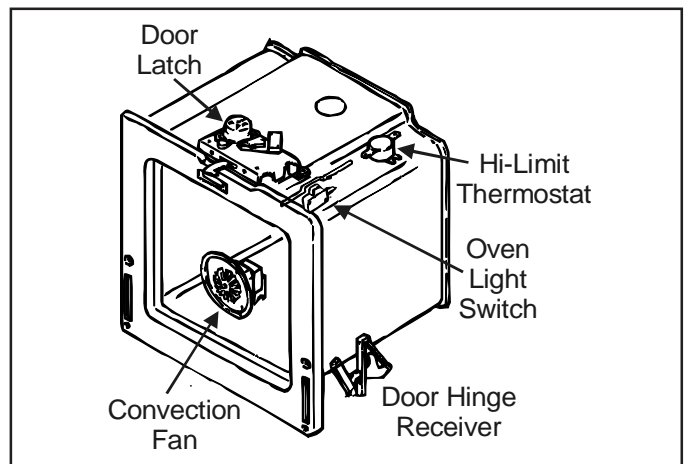

Disassembly Procedures



CAUTION

To avoid risk of electrical shock, personal injury or death; disconnect power and gas before servicing, unless testing requires power and/or gas.

Oven Door Latch Replacement

1. Remove control panel, see "Control Panel Removal" procedure.
2. Remove screws securing door latch to the front of the oven cavity outer shell.
3. Slide oven door latch assembly forward to diagnose.
4. Label and disconnect wire terminals from latch assembly.
5. Reverse procedure to reinstall door latch assembly.

Oven Door Hinge Removal

1. Remove power from unit.
2. Remove unit from installation position, see "Removing and Replacing Range" procedure.
3. Remove oven door, see "Oven Door Removal" procedure.
4. Remove front side trim, see "Front Side Trim Removal" procedure.
5. Remove screws securing side panel to chassis.
6. Remove the top and bottom screws securing hinge receiver to the front frame.
7. Remove hinge receiver from oven chassis.
8. Reverse procedure to reinstall oven door hinge.

Bottom Access Panel Removal (Select Models)

1. Grasp top of bottom access panel and gently pull down and out.
2. Reverse procedure to reinstall bottom access panel.

Bottom Access Panel Disassembly (Select Models)

1. Grasp top of bottom access panel and gently pull down and out.
2. Remove screws securing front panel to glass panel.
3. Reverse procedure to reassemble bottom access panel.

NOTE: See page 30 for illustration.

Storage Drawer Removal (Select Models)

1. Slide storage drawer out until drawer stops.
2. Press tabs up or down (depending on side) on storage drawer "stops" to release drawer from slide track.
3. Slide storage drawer completely out of slide track.
4. Reverse procedure to reinstall storage drawer.

Storage Drawer Track Disassembly (Select Models)

1. Remove storage drawer, see "Storage Drawer Removal (Select Models)" procedure.
2. Place drawer on a protected surface.
3. Remove screws securing front panel to glass panel.
4. Remove screws front panel to storage drawer.
5. Remove screws securing "sliding tracks" to storage drawer.
6. Reverse procedure to reassemble.

Storage Drawer Disassembly

1. Remove warming door, see "Storage Drawer Removal (Select Models)" procedure.
2. Place door on a protected surface.
3. Remove screws securing front panel to glass panel.
4. Remove screws securing front panel to storage drawer.
5. Remove screws securing "sliding tracks" to storage drawer.
6. Reverse procedure to reassemble storage drawer.

NOTE: See page 30 for illustration.

Warming Drawer Removal (Select Models)

1. Slide warming drawer out until drawer stops.
2. Press tabs up or down (depending on side) on warming drawer "stops" to release drawer from slide track.
3. Slide warming drawer completely out of slide track.
4. Reverse procedure to reinstall warming drawer.

Warming Drawer Element Removal (Select Models)

1. Remove warming drawer, see "Warming Drawer Removal" procedure.
2. Remove screws securing element brackets to oven chassis and element.
3. Remove element and slide toward front of unit.
4. Label and disconnect element wiring.
5. Reverse procedure to reinstall warming drawer element.

Disassembly Procedures



CAUTION

To avoid risk of electrical shock, personal injury or death; disconnect power and gas before servicing, unless testing requires power and/or gas.

Warming Drawer Hi-Limit Switch Replacement (Select Models)

1. Remove unit from installation position, see "Removing and Replacing Range" procedure.
2. Remove front side trim, see "Front Side Trim Removal" procedure.
3. Remove warming drawer, see "Warming Drawer Removal (Select Models)" procedure.
4. Remove screws securing side panel to oven chassis.
5. Remove screws securing hi-limit switch to warming drawer support frame.
6. Label and disconnect hi-limit switch wire terminals.
7. Remove hi-limit switch from outside the warming drawer support frame.

NOTE: Do not pull hi-limit switch and wiring through cavity wall.

8. Reverse procedure to reinstall warming drawer hi-limit switch.

Oven Door Removal



WARNING

To avoid risk of personal injury or property damage, do not lift oven door by the handle.

1. Open oven door slightly and grasp door on both sides.
2. Lift up and off the hinge receivers.
3. Reverse procedure to reinstall oven door.

Warming Drawer Track Disassembly (Select Models)

1. Remove warming drawer, see "Warming Drawer Removal (Select Models)" procedure.
2. Place door on a protected surface.
3. Remove screws securing front panel to glass panel.
4. Remove screws front panel to warming drawer.
5. Remove screws securing "sliding tracks" to warming drawer.
6. Reverse procedure to reassemble warming drawer.

Warming Drawer Disassembly

1. Remove warming door, see "Warming Drawer Removal (Select Models)" procedure.
2. Place door on a protected surface.
3. Remove screws securing front panel to glass panel.
4. Remove screws securing front panel to warming drawer.
5. Remove screws securing "sliding tracks" to warming drawer.
6. Reverse procedure to reassemble oven door.

NOTE: See page 30 for illustration.

Oven Door Disassembly

1. Remove oven door, see "Oven Door Removal" procedure.
2. Place door on a protected surface.
3. Remove screws securing door glass to oven door trim and frame (screws located along the top and bottom edge of oven door).

NOTE: Proceed with the following steps if replacing door handle.

4. Remove screws securing door handle to door glass.
5. Remove screws securing upper and lower shields.
6. Remove screws securing door baffle.
7. Remove oven door insulation.
8. Remove screws securing outer and inner door glass (and glass frame).
9. Remove oven door liner, if replacing.
10. Reverse procedure to reassemble oven door.

NOTE: See page 30 for illustration.

Disassembly Procedures



CAUTION

To avoid risk of electrical shock, personal injury or death; disconnect power and gas before servicing, unless testing requires power and/or gas.

Oven Door, Warming Drawer/ Storage Drawer and Access Panel Disassembly

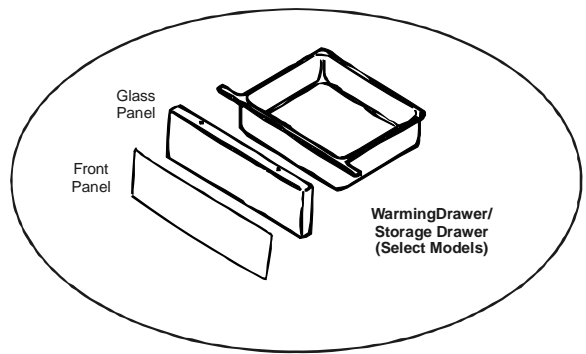
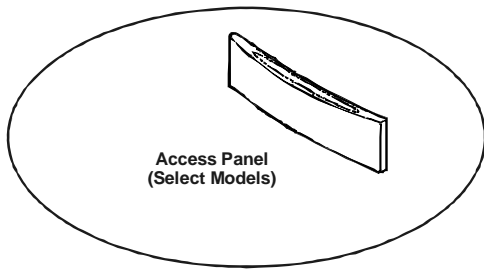
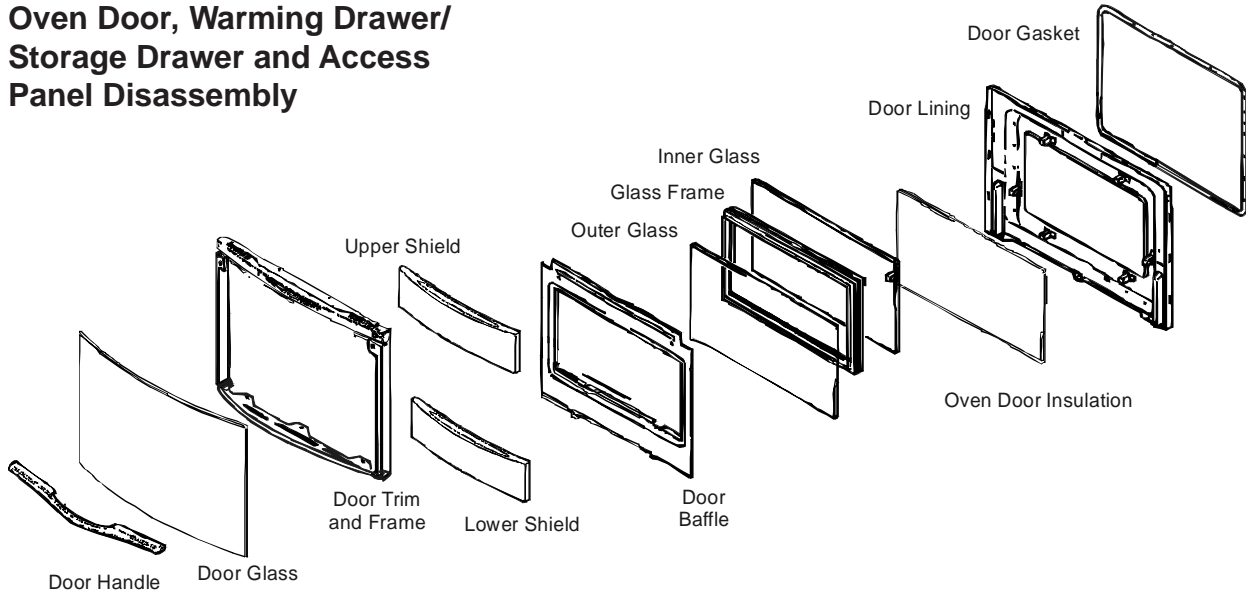

Appendix A

The Installation information provided in this service manual is representative of a limited number of models. Reference the customer's Installation literature included with the product, order a copy (if needed), or consult Jenn-Air's website for the specific model.

www.jennair.com



Jenn-Air Updraft Gas Slide-In Range

Cuisinière à gaz encastrable à circulation ascendante Jenn-Air/
Estufa deslizante a gas de corriente ascendente Jenn-Air

Installation Instructions/Instructions d'installation/Instrucciones de Instalación

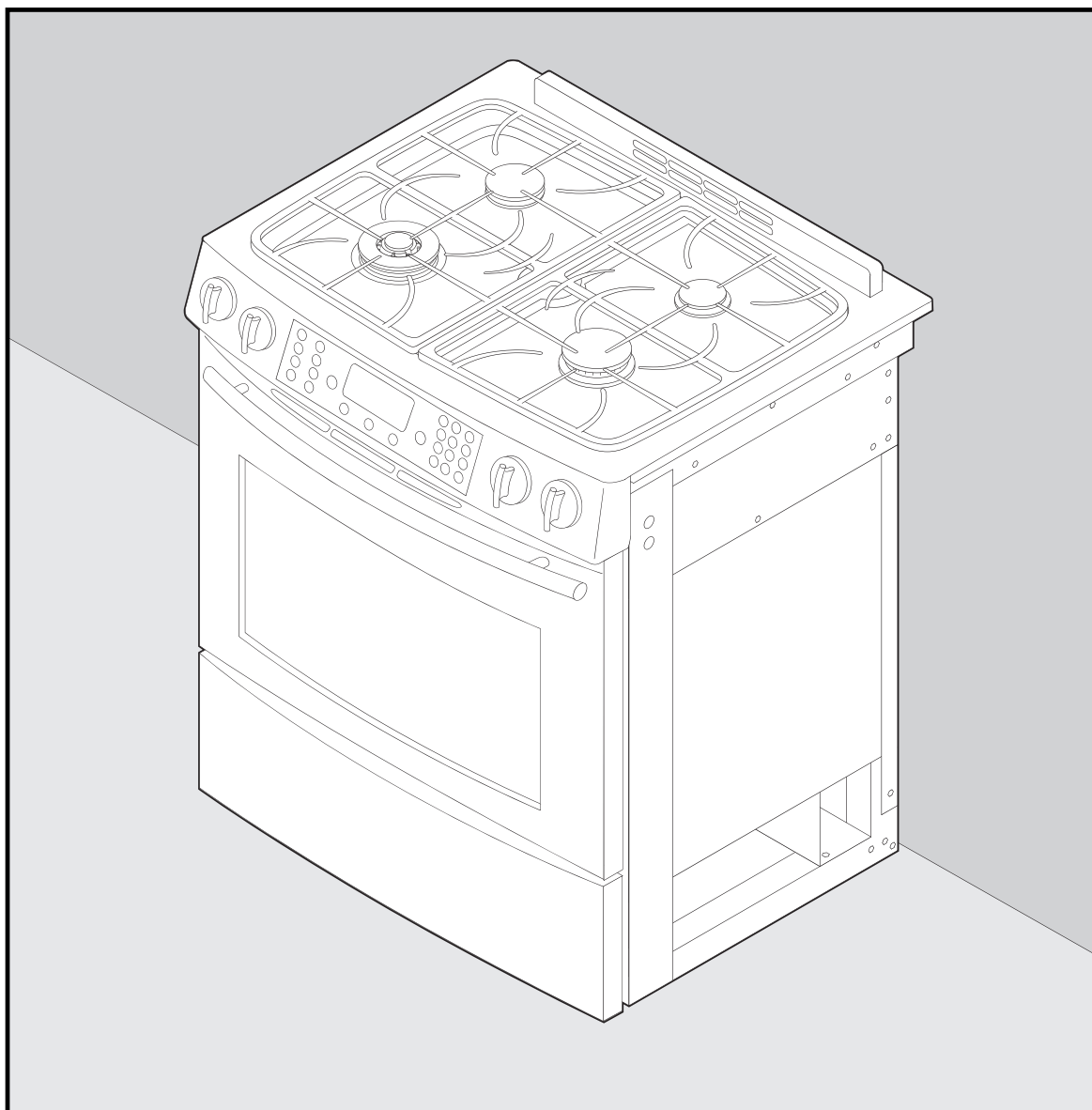

INSTALLER: Leave these instructions with the appliance./INSTALLATEUR : Laissez ces instructions avec l'appareil./
INSTALADOR: Deje estas instrucciones con el electrodoméstico.

Printed in USA

©2005 Maytag Corporation

Rev 0-10/05 8101P697-60

Installation Instructions

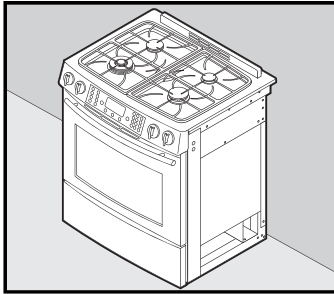

Jenn-Air Updraft Gas Slide-In Range

INSTALLATION INSTRUCTIONS

PLEASE KEEP THIS MANUAL FOR FUTURE REFERENCE

This manual is intended to assist in the initial installation and adjustments of the range.

- Only qualified personnel should install or service this range.
- Read "Safety Instructions" in Use & Care book before using range.
- Improper installation, adjustment, alteration, service, maintenance or use of range can result in serious injury or property damage.
- Installer, take care not to damage flooring.

CAUTIONS

Do not lift or move range by grasping door handles or main top.



This range has been designed in accordance with the requirements of various safety agencies and complies with the maximum allowable wood cabinet temperatures of 194°F. If this range is installed with cabinets that have a lower working temperature than 194°F, discoloration, delamination or melting may occur.

Place range in a well lit area. Do not set range over holes in the floor or other locations where it may be subject to strong drafts. Any opening in the wall behind the range and in the floor under the range should be sealed. Make sure the flow of cooling/ventilation air is not obstructed below the range. Note: A range should NOT be installed over kitchen carpeting.

High Altitude Notice: The specified gas burner ratings typically apply to elevations up to 2000 feet. For higher altitudes, the rates may need to be reduced to achieve satisfactory operation. A local certified gas servicer will be able to advise if a reduction is necessary.

WARNING

Electrical Grounding Instructions – This appliance is equipped with a (three-prong) grounding plug for your protection against shock hazard and should be plugged directly into a properly grounded receptacle. Do not cut or remove the grounding prong from this plug.

CONNECTING THE RANGE

Electric Supply

The appliance, when installed, must be electrically grounded in accordance with local codes or, in the absence of local codes, with the National Electrical Code, ANSI/NFPA 70. In Canada the range must be installed in accordance with the current CSA Standard C22.1 - Canadian Electrical Code Part 1.

WARNING



• ALL RANGES CAN TIP AND CAUSE INJURIES TO PERSONS.

• INSTALL ANTI-TIP DEVICES PACKED WITH RANGE.



• FOLLOW ALL INSTALLATION INSTRUCTIONS.

A risk of range tip-over exists if the appliance is not installed in accordance with the provided installation instructions. The proper use of the ANTI-TIP device minimizes the risk of TIP-OVER. In using this device the consumer must still observe the safety precautions as stated in the USE and CARE MANUAL and avoid using the oven doors as a step stool. Installation instructions are provided for wood and cement in either floor or wall. Any other type of construction may require special installation techniques as deemed necessary to provide adequate fastening of the ANTI-TIP bracket to the floor or wall. The bracket must be installed to engage the RIGHT rear leveling foot. Install the bracket as shown in step 2.

MOBILE HOMES

The installation of a range designed for mobile home installation must conform with the Manufactured Home Construction and Safety Standard, Title 24 CFR, Part 3280 (formerly the Federal Standard for Mobile Home Construction and Safety, Title 24 HUD, Part 280) or, when such standard is not applicable, the Standard for Manufactured Home Installations ANSI A225.1/NFPA 501A, or with local codes. In Canada the range must be installed in accordance with the current CSA Standard C22.1 - Canadian Electrical Code Part 1 and Section Z240.4.1 - Installation Requirements for Gas Burning Appliances in Mobil Homes (CSA Standard CAN/CSA - Z240MH).

RECREATIONAL PARK TRAILERS

The installation of a range designed for recreational park trailers must conform with state or other codes or, in the absence of such codes, with the Standard for Recreational Park Trailers, ANSI A119.5-latest edition. In Canada the range must be installed in accordance with CAN/CSA - Z240.6.2 - Electrical Requirements for R.V.'s (CSA Standard CAN/CSA - Z240 RV Series) and Section Z240.4.2 - Installation Requirements for Propane Appliances and Equipment in R.V.'s (CSA Standard CAN/CSA - Z240 RV Series).

Electrical Supply Connection

The range requires 120 volts, 60 cycle alternating current from a dedicated grounded outlet with a 15 amp circuit breaker. See serial plate for rating, located on front frame behind storage drawer. User may experience occasional circuit tripping if Ground Fault Circuit Interrupter (GFCI) outlet or breaker is in use.

Installation Instructions

CONNECTING THE RANGE (cont)

Gas Supply

Installation of this range must conform with local codes or, in the absence of local codes, with the National Fuel Gas Code, ANSI Z223.1-latest edition. In Canada the range must be installed in accordance with the current CGA Standard CAN/CGA-B149 - Installation Codes for Gas Burning Appliances and Equipment and/or local codes.

In The Commonwealth Of Massachusetts

This product must be installed by a licensed plumber or gas fitter when installed within the Commonwealth of Massachusetts. A "T" handle type manual gas valve must be installed in the gas supply line to this appliance. A flexible gas connector, when used, must not exceed a length of three (3) feet / 36 inches.

⚠ WARNING

Gas leaks may occur in your system and result in a dangerous situation. Gas leaks may not be detected by smell alone. Gas suppliers recommend you purchase and install an UL approved gas detector. Install and use in accordance with manufacturer's instructions.

GAS SUPPLY CONNECTION

A QUALIFIED SERVICEMAN OR GAS APPLIANCE INSTALLER MUST MAKE THE GAS SUPPLY CONNECTION. Leak testing of the appliance shall be conducted by the installer according to the instructions given in Step 7.

Apply a non-corrosive leak detection fluid to all joints and fittings in the gas connection between the supply line shut-off valve and the range. Include gas fittings and joints in the range if connections were disturbed during installation. Check for leaks! Bubbles appearing around fittings and connections will indicate a leak. If a leak appears, turn off supply line gas shut-off valve, tighten connections, turn on the supply line gas shut off valve, and retest for leaks.

CAUTION: NEVER CHECK FOR LEAKS WITH A FLAME. WHEN LEAK CHECK IS COMPLETE, WIPE OFF ALL RESIDUE.

NATURAL GAS SUPPLY LINE MUST HAVE A NATURAL GAS SERVICE REGULATOR. INLET PRESSURE TO THIS APPLIANCE SHOULD BE REDUCED TO A MAXIMUM OF 14 INCHES WATER COLUMN (0.5 POUNDS PER SQUARE INCH (P.S.I.) LIQUEFIED PETROLEUM (L.P.)/PROPANE GAS SUPPLY LINE MUST HAVE A L.P. GAS PRESSURE REGULATOR. INLET PRESSURE TO THIS APPLIANCE SHOULD BE REDUCED TO A MAXIMUM OF 14 INCHES WATER COLUMN (0.5 P.S.I.). INLET PRESSURES IN EXCESS OF 0.5 P.S.I. CAN DAMAGE THE APPLIANCE PRESSURE REGULATOR AND OTHER GAS COMPONENTS IN THIS APPLIANCE AND CAN RESULT IN A GAS LEAK.

NOTE: It is recommended to use a new CSA certified 1/2" flexible connector no longer than 36" (91.4 cm) with a minimum BTU/HR rating of 60,000 be used. Rigid pipe may also be used.

Gas supply pressure for testing regulator must be at least 1" water column pressure above manifold pressure shown on serial plate.

Check Pressure of House Piping System

1. The appliance and its individual shutoff valve must be disconnected from the gas supply piping system during any pressure testing of that system at test pressures in excess of 1/2 lbs./sq. in. (3.5 kPa) (13.8 in. water column).
2. The appliance must be isolated from the gas supply piping system by closing its individual manual shutoff valve during any pressure testing of the gas supply piping system at test pressures equal to or less than 1/2 lbs./sq. in. (3.5 kPa) (13.8 in. water column).

A GAS SHUT-OFF VALVE SHOULD BE PUT IN AN ACCESSIBLE LOCATION IN THE SUPPLY LINE AHEAD OF THE RANGE, FOR TURNING ON AND TURNING OFF GAS SUPPLY. CONNECTOR NUTS MUST NOT BE CONNECTED DIRECTLY TO PIPE THREADS. THE CONNECTORS MUST BE INSTALLED WITH ADAPTORS PROVIDED WITH THE CONNECTOR.

The house piping and/or range connector used to connect the range to the main gas supply must be clean, free of metal shavings, rust, dirt and liquids (oil or water). Dirt, etc. in the supply lines can work its way into the range manifold and in turn cause failure of the gas valves or controls and clog burners and/or pilot orifices.

HOW TO REMOVE RANGE FOR SERVICING

Follow these procedures to remove appliance for servicing:

1. Slide range forward to disengage range from the anti-tip bracket.
2. Shut off gas supply to appliance.
3. Disconnect electrical supply to appliance, if equipped.
4. Disconnect gas supply tubing to appliance.
5. Reverse procedure to reinstall. If gas line has been disconnected, check for gas leaks after reconnection.
6. To prevent range from accidentally tipping, range must be secured to the floor by sliding rear leveling leg into the anti-tip bracket.

NOTE: A qualified servicer should disconnect and reconnect the gas supply. The servicer MUST follow installation instructions provided with the gas appliance connector and the warning label attached to the connector.

⚠ WARNING

DISCONNECT ELECTRICAL SUPPLY BEFORE SERVICING THE APPLIANCE.

SERVICE-PARTS INFORMATION

When your range requires service or replacement parts, contact your dealer or authorized service agency. Please give the complete model and serial number of the range which is located on front frame behind storage drawer.

Your range may not be equipped with some of the features referred to in this manual.

Installation Instructions

IMPORTANT: Keep for Local Inspector/IMPORTANT : À conserver pour l'inspecteur local/
IMPORTANTE: Guarde esta información para el inspector local.

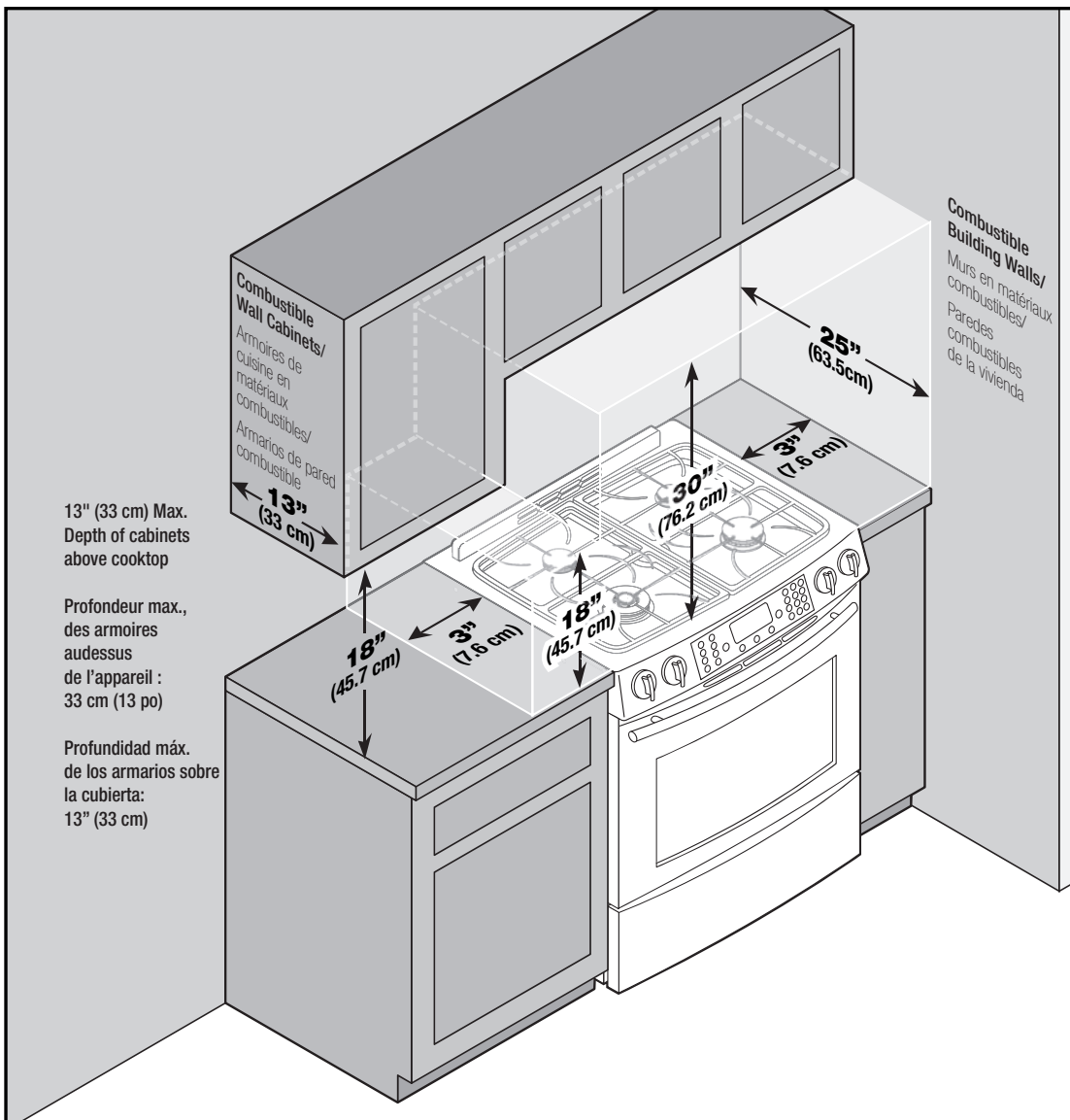

NOTE: Figure may not be representative of actual unit./REMARQUE : L'illustration peut ne pas présenter l'appareil actuel./NOTA: La figura puede no ser exacta a la unidad.

CLEARANCE DIMENSIONS

Range may be installed with zero inches clearance adjacent to (against) combustible construction at the rear and on the sides below the cooktop. For complete information in regard to the installation of wall cabinets above the range and clearances to combustible wall above the cooking top see the installation drawings. For SAFETY CONSIDERATIONS do not install a range in any combustible cabinetry which is not in accord with the installation drawings.

* **NOTE:** 30 inch (76.2 cm) dimension between cooking top and wall cabinet shown on illustration does not apply to ranges with an elevated oven or microwave. The installation instructions of the elevated oven will specify the minimum acceptable dimension between the cooktop and elevated oven. The 30 inch (76.2 cm) dimension may be reduced to not less than 24 inches (61 cm) when the wall cabinets in a domestic home are protected with fireproof materials in accordance with American National Standards - National Fuel Gas Code or in mobile homes when they are protected with fireproof materials in accordance with the Federal Standard for Mobile Home Construction and Safety.

To eliminate the risk of burns or fire by reaching over heated surface units, cabinet storage space located above the surface units should be avoided. If cabinet storage is to be provided, the risk can be reduced by installing a range hood that projects horizontally a minimum of 5 inches (13 cm) beyond the bottom of the cabinets

Installation Instructions

**IMPORTANT: Keep for Local Inspector (cont)/IMPORTANT : À conserver pour l'inspecteur local (suite)/
IMPORTANTE: Guarde esta información para el inspector local (cont.)**

DÉGAGEMENTS

La cuisinière peut être installée avec un dégagement nul contre des matériaux combustibles à l'arrière et sur les côtés en dessous de la table de cuisson. Pour des renseignements complets concernant l'installation des armoires au-dessus de la cuisinière et les dégagements aux parois combustibles au-dessus de la surface de cuisson, consultez les schémas sur l'installation. Pour des RAISONS DE SÉCURITÉ, n'installez pas une cuisinière dans des armoires en matériaux combustibles non conformes aux schémas de l'installation.

* REMARQUE : La dimension de 76,2 cm (30 po) entre la surface de cuisson et les armoires murales présentées sur l'illustration ne concerne pas les cuisinières avec un four surélevé ou un micro-ondes. Les instructions d'installation du four surélevé précisent la dimension minimale acceptable entre la surface de cuisson et le four surélevé. La dimension de 76,2 cm (30 po) peut être réduite à pas moins de 61 cm (24 po) lorsque les armoires murales d'une résidence sont protégées par des matériaux ignifuges conformément aux normes de l'American National Standards – National Fuel Gas Code (Code national des combustibles gazeux), ou lorsque les armoires murales d'une maison mobile sont protégées par des matériaux ignifuges selon la norme fédérale : Mobile Home construction and Safety (norme de sécurité et de construction des maisons mobiles).

Pour éliminer le risque de brûlure ou d'incendie, en passant la main au-dessus des éléments de surface chauffés, l'espace de rangement dans les armoires situées au-dessus des éléments de surface doit être évité. Si une armoire de rangement existe, le risque peut être réduit en installant une hotte d'extraction qui dépasse horizontalement d'un minimum de 13 cm (5 po) de la partie inférieure des armoires.

DIMENSIONES DE LOS ESPACIOS DE DESPEJE

Esta estufa se puede instalar sin espacios de despeje contra superficies combustibles en la parte trasera y a los costados de la misma por debajo de la cubierta. Para obtener información completa sobre la instalación de los armarios sobre la cubierta y los espacios de despeje para las paredes combustibles sobre la cubierta vea las figuras de instalación. Por RAZONES DE SEGURIDAD, no instale una estufa en ninguna ubicación con armarios combustibles que no concuerden con las figuras de instalación.

* NOTA: El despeje de 30 pulgadas (76,2 cm) entre la cubierta de cocción y el armario que se muestra en la figura no se aplica a las estufas con hornos elevados o a los microondas. Las instrucciones de instalación del horno elevado especificarán el espacio mínimo entre la cubierta y el horno elevado. El despeje de 30 pulgadas (76,2 cm) puede ser reducido a no menos de 24 pulgadas (61 cm) cuando los armarios del hogar están protegidos con materiales a prueba de fuego de acuerdo con las Normas Nacionales de Estados Unidos (ANS) y el Código Nacional de Gas o en las casas rodantes cuando las mismas están protegidas con materiales a prueba de fuego de acuerdo con la Norma Federal de Construcción y Seguridad de Viviendas Móviles.

Para eliminar el riesgo de quemaduras o de incendios cuando se intenta alcanzar algún objeto sobre los elementos superiores, evite almacenar artículos en los armarios que están sobre la estufa. Si se instala un armario sobre la cubierta, se puede reducir el riesgo instalando una campana de ventilación que se proyecte horizontalmente en un mínimo de 5 pulgadas (13 cm) más allá de la base de los armarios.



WARNING / AVERTISSEMENT / ADVERTENCIA

THIS PRODUCT SHOULD NOT BE INSTALLED BELOW VENTILATION TYPE HOOD SYSTEM THAT DIRECTS AIR IN A DOWNWARD DIRECTION. THESE SYSTEMS MAY CAUSE IGNITION AND COMBUSTION PROBLEMS WITH THE GAS BURNERS RESULTING IN PERSONAL INJURY AND MAY AFFECT THE COOKING PERFORMANCE OF THE UNIT.

NOTE: THE FIGURE MAY NOT ACCURATELY REPRESENT YOUR RANGE COOKTOP; HOWEVER, THIS WARNING APPLIES TO ALL GAS COOKING PRODUCTS.

CE PRODUIT NE DOIT PAS ÊTRE INSTALLÉ SOUS UNE HOTTE D'EXTRACTION QUI RENVOIE L'AIR VERS LE BAS.

CES SYSTÈMES PEUVENT ENTRAÎNER DES PROBLÈMES D'INFLAMMATION ET DE COMBUSTION AVEC LES BRÛLEURS À GAZ, ENTRAÎNANT DES BLESSURES ET RISQUANT D'AFLECTER LA PERFORMANCE DE CUISSON DE L'APPAREIL.

REMARQUE : L'ILLUSTRATION PEUT NE PAS REPRÉSENTER PRÉCISÉMENT LA TABLE DE CUISSON DE VOTRE CUISINIÈRE; CEPENDANT, CET AVERTISSEMENT CONCERNE TOUS LES APPAREILS DE CUISSON À GAZ.

ESTE PRODUCTO NO SE DEBE INSTALAR DEBAJO DE SISTEMAS DE CAMPANAS DE VENTILACIÓN QUE DIRIJAN EL FLUJO DE AIRE HACIA ABAJO.

ESTOS SISTEMAS PUEDEN CAUSAR PROBLEMAS DE ENCENDIDO Y DE COMBUSTIÓN DE LOS QUEMADORES, LO QUE PUEDE RESULTAR EN LESIONES PERSONALES Y AFECTAR EL RENDIMIENTO DE LA COCCIÓN DE LA UNIDAD.

NOTA: LA FIGURA PUEDE NO REPRESENTAR CON EXACTITUD SU CUBIERTA. SIN EMBARGO, ESTA ADVERTENCIA SE APLICA A TODOS LOS PRODUCTOS DE COCCIÓN A GAS.

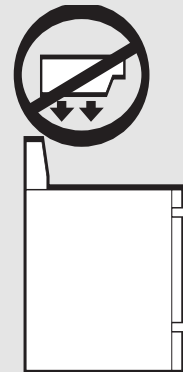

Installation Instructions

Dimensions/Dimensions/Dimensiones

If end cabinet is not present, side panel kit UXA11004A (B= black, W= white, S= Stainless) may be ordered from dealer.

If cabinet backslash behind unit is not present, kit UXA9107AA (B= black, S=stainless, W= white) may be ordered from dealer.

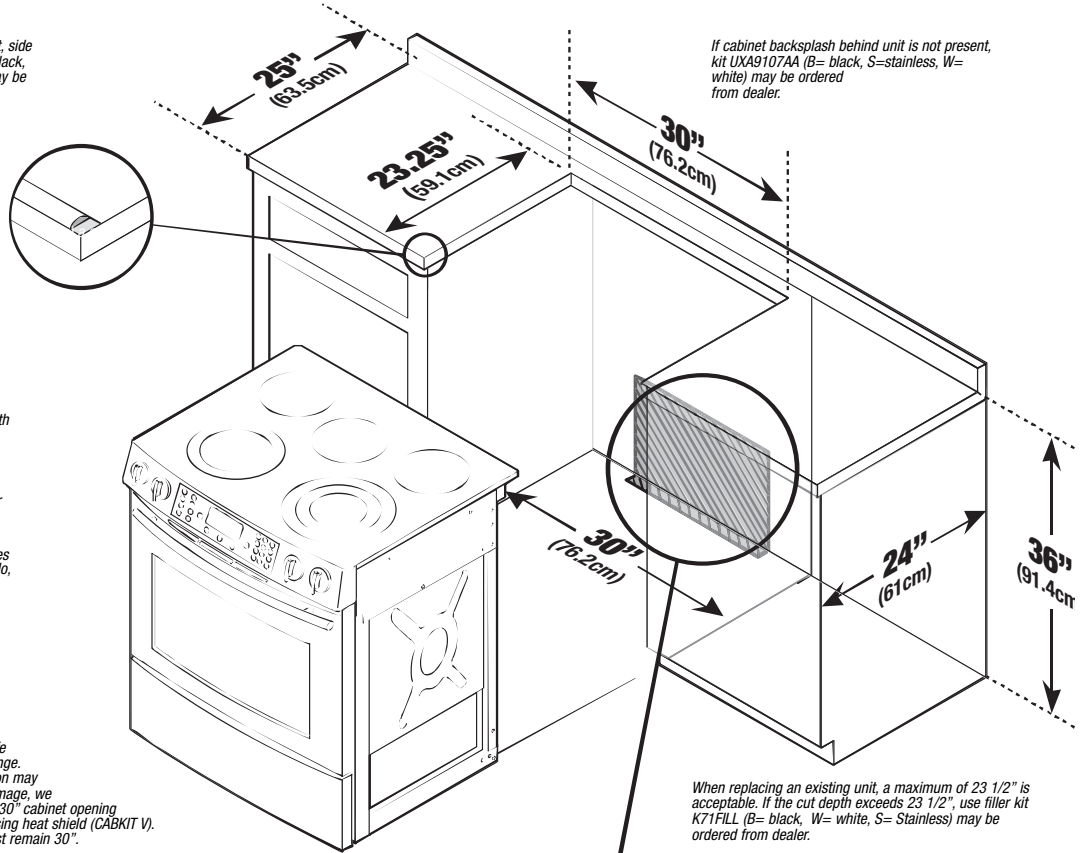

NOTE: For counter tops with formed front edge, shave raised section to clear top.

REMARQUE: Pour les hauts de comptoir avec un rebord avant moulé, raboter la section relevée pour dégager le haut.

NOTA: Para los mostradores con borde delantero formado, cepille la sección elevada para que la parte superior calce.

CAUTION: Some white European style cabinets are equipped with delicate white vinyl drawer and door fronts. The vinyl may not be designed to withstand the heat produced by the normal safe operation of a self-clean range. Discoloration or delamination may occur. To avoid possible damage, we recommend increasing the 30" cabinet opening to 31 1/4" minimum and using heat shield (CABKIT V). The countertop cut-out must remain 30".

ATTENTION: Certaines armoires de couleur blanche et de style européen sont équipées de façades de porte et de tiroir en vinyle blanc fragile. Le vinyle peut ne pas être conçu pour résister à la chaleur produite par un autonettoyage normal. Il peut se produire une décoloration ou une désstratification. Pour éviter le risque de dommages, nous vous recommandons d'agrandir l'ouverture dans les armoires de 30 po (76,2 cm) à 31 1/4 po (79,4 cm) minimum et d'utiliser un ensemble d'écran thermique (CABKIT V). L'ouverture dans le plan de travail doit toujours être de 30 po (76,2 cm).

When replacing an existing unit, a maximum of 23 1/2" is acceptable. If the cut depth exceeds 23 1/2", use filler kit K71FILL (B= black, W= white, S= Stainless) may be ordered from dealer.

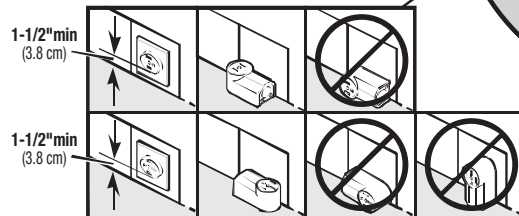
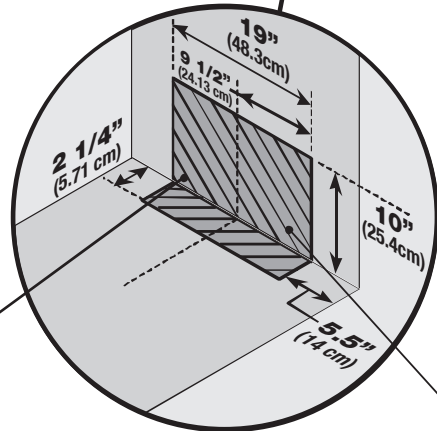

NOTE: As an option to make gas valve accessible, it can be located in the adjacent cabinet.

REMARQUE: Pour que le robinet de gaz soit accessible, il peut être situé dans l'armoire adjacente.

NOTA: A modo opcional para facilitar el acceso a la válvula de gas, la misma puede ser instalada en el gabinete adyacente.

Important: Because of continuing product improvements, Maytag reserves the right to change specifications without notice. Dimensional specifications are provided for planning purposes only.

Important : En raison de l'amélioration continue de ses produits, Maytag se réserve le droit de changer les spécifications sans préavis. Les dimensions ne sont fournies qu'à titre indicatif.

Importante: Debido a las mejoras continuas del producto, Maytag se reserva el derecho de cambiar sus especificaciones sin aviso previo. Las especificaciones dimensionales se proporcionan para propósitos de planificación únicamente.

Installation Instructions

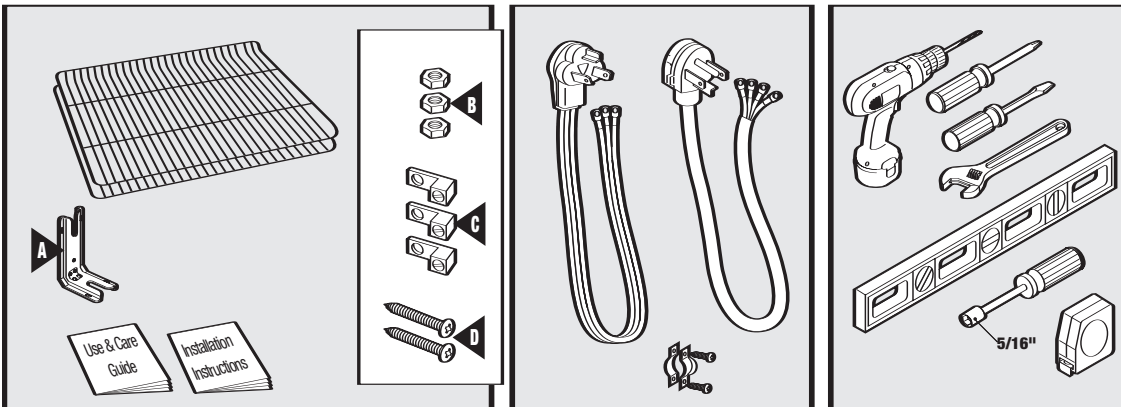

Included./Compris./Se incluye.

Not Included./Non inclus./No se incluye.

Tools Needed./Outils nécessaires./Herramientas Necesarias.

If you have LP (propane) it is recommended to initiate the conversion prior to installation. The conversion instruction kit can be found on the regulator shelf behind the shield./
 Avec le GPL, il est recommandé de faire la conversion avant l'installation. L'ensemble de conversion se trouve sur la tablette du détendeur derrière le blindage./
 Si utiliza gas LP (propano), se recomienda que inicie la conversión antes de realizar la instalación. Puede encontrar el kit de instrucciones en el estante del regulador detrás del protector.

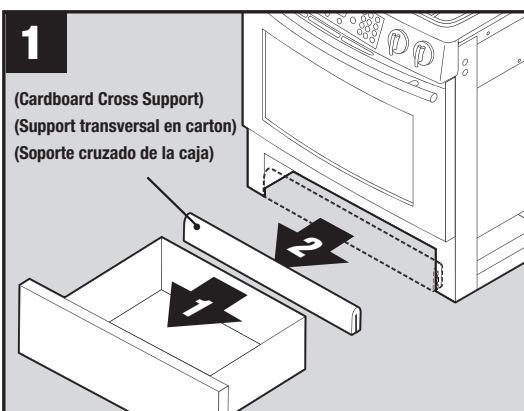
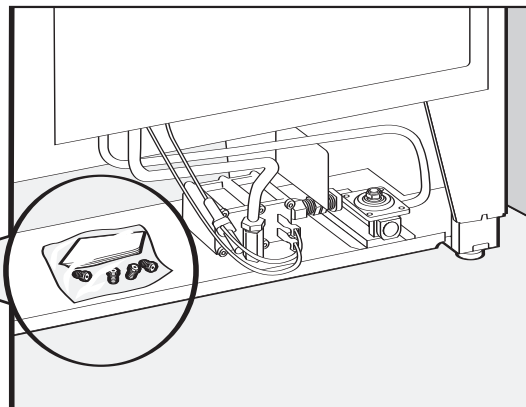

Remove drawer (check Use and Care manual for directions) and insure all packing (cardboard cross support) is removed and discarded./
 Retirez le tiroir (vérifiez le manuel d'utilisation et d'entretien pour les instructions) et assurez-vous que tout le matériau d'emballage (support transversal en carton) est enlevé et jeté./Retire el cajón (consulte el manual de uso y cuidado para obtener instrucciones) y asegúrese de que todo el material de empaque (soporte transversal de la caja de cartón) sea removido y desechado.

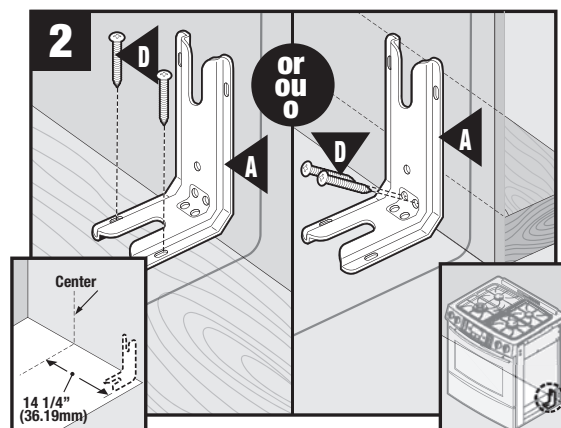

Drill 1/8" (3mm) holes. Mount ANTI-TIP bracket to wall or floor with 2 screws./
 Percez des trous de 1/8 po (3 mm). Installez le support ANTIREVERSEMENT au mur ou au sol avec deux vis./Taladre agujeros de 1/8" (3 mm). Instale el soporte ANTIVUELCO en la pared o en el piso usando 2 tornillos.

Installation Instructions

3

TURN OFF GAS SUPPLY TO PRODUCT.
COUPEZ L'ALIMENTATION EN GAZ DE L'APPAREIL.
CIERRE EL SUMINISTRO DE GAS AL PRODUCTO.

4

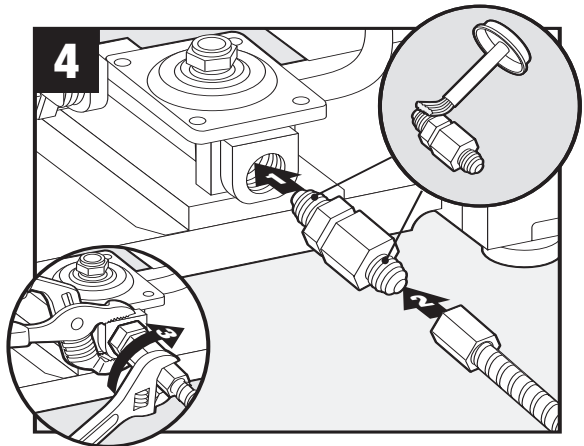

Apply pipe thread compound approved for LP gas to all threads. Always hold the regulator in stable position while attaching gas supply line./Appliquez sur tous les filetages un composé à joints approuvé pour le GPL. Tenez toujours le détendeur en position stable lors du raccordement de la conduite d'alimentation en gaz./Aplique compuesto para rosca de tuberías aprobado para gas LP a todas las roscas. Siempre sostenga el regulador en una posición estable mientras conecta la tubería de suministro.

5

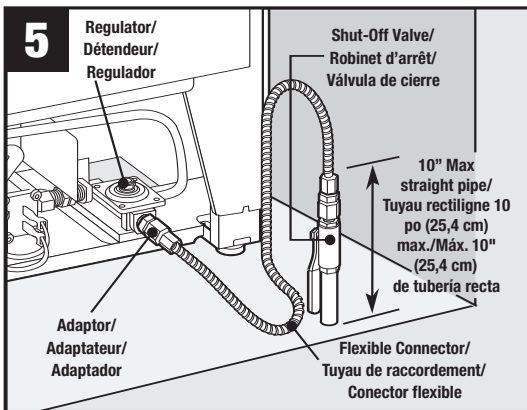

Only qualified personnel should install range. Must be installed in accordance with local codes. See instructions in front of this manual./Seul du personnel qualifié doit installer la cuisinière. Elle doit être installée selon les codes locaux. Voyez les instructions au début de ce manuel./ La estufa sólo debe ser instalada por personal calificado. La estufa debe instalarse de acuerdo con los códigos locales. Vea las instrucciones en la parte delantera de este manual.

6

TURN ON GAS SUPPLY TO PRODUCT.
OUVREZ L'ALIMENTATION EN GAZ DE L'APPAREIL.
ABRA EL SUMINISTRO DE GAS AL PRODUCTO.

7

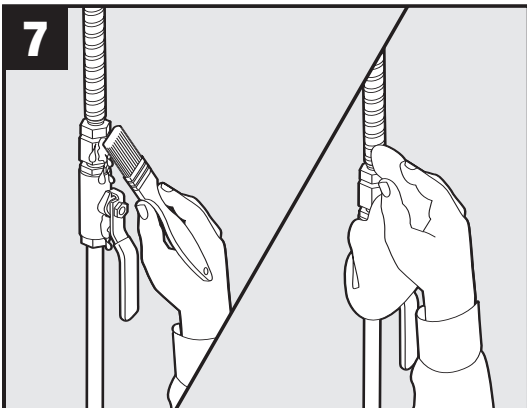

Check all gas connection joints and fittings for leaks with a non-corrosive leak detection fluid, then wipe off./Vérifiez l'absence de fuite à tous les raccords de gaz avec un liquide de détection des fuites non corrosif, puis essuyez-le./Verifique todas las conexiones y juntas del suministro de gas a la estufa usando un líquido de detección de escapes no corrosivo para asegurarse de que no hayan escapes. Limpie el líquido cuando haya terminado.

8

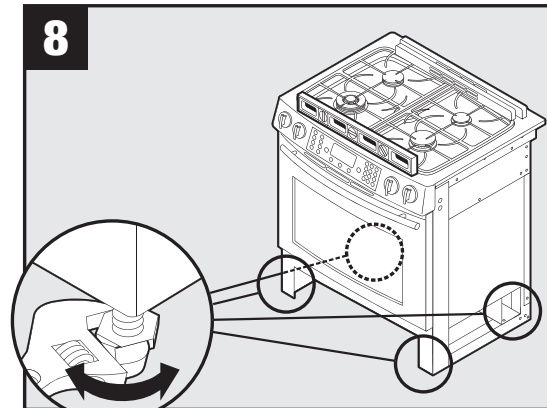

Adjust legs. **Note:** Check counter top height (see dimensions) to allow range top to clear countertop. Install, take caution not to damage floor./Ajustez les pieds. **Remarque:** Vérifiez la hauteur du plan de travail (voyez les dimensions) pour que le dessus de la cuisinière se trouve au-dessus du plan de travail. Installeur: faites attention de ne pas endommager le sol./Ajuste los tornillos niveladores. **Nota:** Verifique la altura de la encimera (vea las dimensiones) para permitir que la parte superior de la estufa pase por la misma. Instalador: tenga cuidado de no dañar el piso.

Installation Instructions

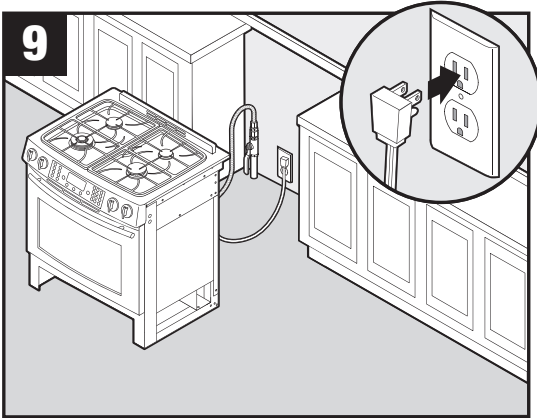

9
Insert plug into grounded outlet./Insérez la fiche dans la prise mise à la terre./Conecte el enchufe en un tomacorriente puesto a tierra.

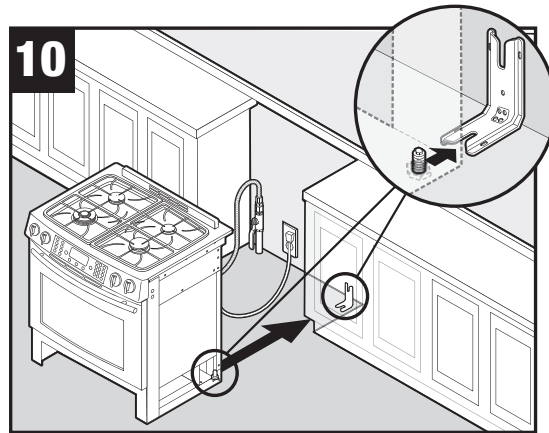

10
Slide range into position. Installer, take caution not to damage floor. Do not tilt range side-to-side; may damage end trim./ Introduisez la cuisinière en place. Installateur : N'endommagez pas le sol. N'inclinez pas la cuisinière sur un côté, au risque d'endommager la garniture./ Deslice la estufa a su lugar definitivo. Instalador: tenga cuidado de no dañar el piso. No incline la estufa de lado a lado; se podría dañar el marco del borde.

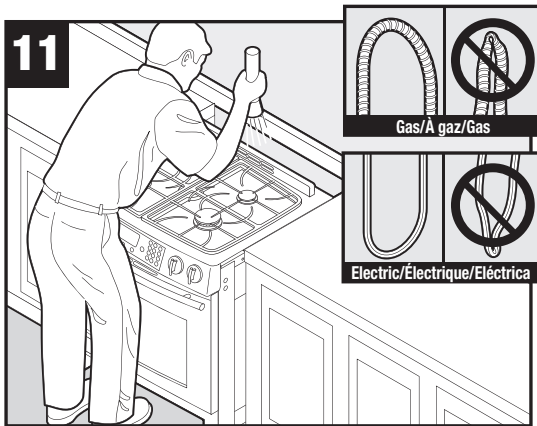

11
Make sure flexible connector and electrical cord are not kinked./ Assurez-vous que le raccord flexible et le cordon d'alimentation ne sont pas entortillés./Asegúrese de que el conector flexible y el cordón eléctrico no estén doblados.

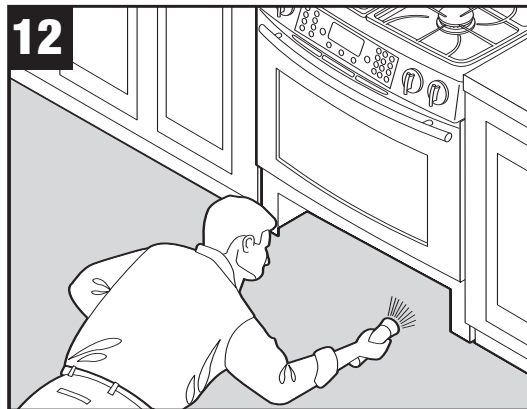

12
Check leg position in ANTI-TIP bracket./Vérifiez la position du pied dans la bride ANTI-BASCULEMENT./Verifique la posición de la pata en el soporte ANTIVUELCO.

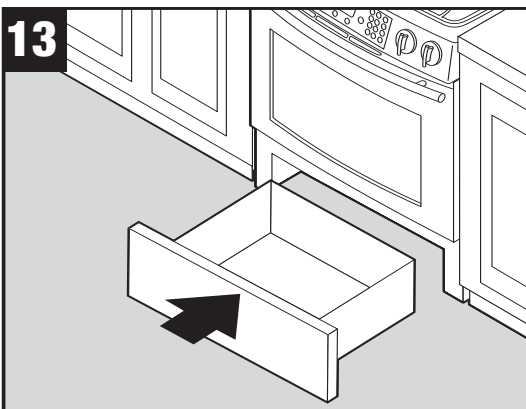

13
Replace drawer./Remplacez le tiroir./Vuelva a instalar el cajón.

Appendix B

The Use and Care information provided in this service manual is representative of a limited number of models. Reference the customer's Use and Care literature included with the product, order a copy (if needed), or consult Jenn-Air's website for the specific model.

www.jennair.com

JENN-AIR® GAS
DOWNDRAFT SLIDE-IN RANGE

USE & CARE
GUIDE



SURFACE COOKING

Low: Use to simmer foods, keep foods warm and melt chocolate or butter. Some cooking may take place on the Low setting if the pan is covered. It is possible to reduce the heat by rotating the knob toward **OFF**. Be sure flame is stable.

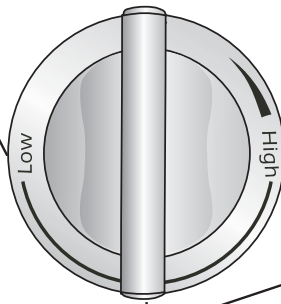

High: Use to bring liquid to a boil, or reach pressure in a pressure cooker. Always reduce setting to a lower heat when liquids begin to boil or foods begin to cook.

An intermediate flame size is used to continue cooking. Food will not cook any faster when a higher flame setting is used than needed to maintain a gentle boil. Water boils at the same temperature whether boiling gently or vigorously.

Surface Controls

CAUTION

- If flame should go out during a cooking operation and the burner does not reignite itself, turn the burner off. If a strong gas odor is detected, open a window and wait five minutes before relighting the burner.
- Be sure all surface controls are set in the **OFF** position prior to supplying gas to the range.
- **NEVER** touch cooktop until it has cooled. Expect some parts of the cooktop, especially around the burners, to become warm or hot during cooking. Use potholders to protect hands.

Setting the controls:

The size and type of cookware will affect the heat setting.

1. Place a pan on the burner grate.
 - The burner flame may lift off or appear separated from the port if a pan is not placed on the grate.
2. Push in and turn the knob to the desired setting.
 - A clicking (spark) sound will be heard and the burner will light.

Important: Each surface burner is equipped to provide automatic reignition if the flame should somehow get blown out.

Pilotless Ignition

Pilotless ignition eliminates the need for a constant standing pilot light. Each surface burner has a spark ignitor. Use care when cleaning around the surface burner.

If the surface burner does not light, check if ignitor is broken, soiled or wet.

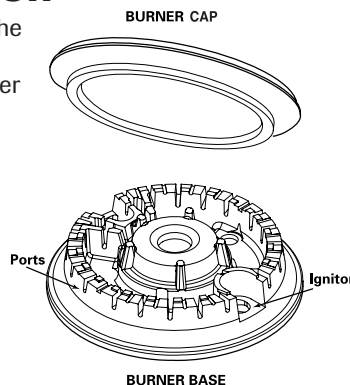

Operating During a Power Failure

CAUTION

When lighting the surface burners, be sure all of the controls are in the **OFF** position. Strike the match first and hold it in position *before* turning the knob on.

1. Hold a lighted match to the desired surface burner head.
2. Push in and turn the control knob slowly on.
3. Adjust the flame to the desired level.

Surface Control Knobs

Use to turn on the surface burners. An infinite choice of heat settings is available from Low to High. At the High setting a detent or notch may be felt. The knobs can be set on or between any of the settings.



Graphics next to the knob identify which burner the knob controls. For example, the graphic at left shows the right front burner location.

Use & Care

Cooktop

To prevent the cooktop from discoloring or staining:

- Clean cooktop after each use.
- Wipe acidic or sugary spills as soon as the cooktop has cooled as these spills may discolor the porcelain.

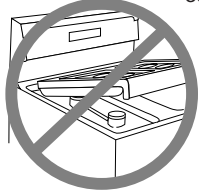

Unlike a range with standard gas burners, this cooktop **does not** lift up nor is it removable. **Do not attempt to lift the cooktop for any reason.**

Sealed Burners

The sealed burners of your range are secured to the cooktop and are not designed to be removed. Since the burners are sealed into the cooktop, boilovers or spills will not seep underneath the cooktop.

However, the burner should be cleaned after each use. The cap portion of the burner is easily removed for cleaning. (See page 7 for cleaning directions.)

The burner caps must be correctly placed on the burner base for proper operation of the burner.

High Performance Burner

There is one 16,000 BTU* high speed burner on your range, located in the right front position. This burner offers higher speed cooking that can be used to quickly bring water to a boil and for large-quantity cooking.

Low Turn Down Burner

This burner is located in the right rear position. The Simmer setting can be used to steam or poach foods, to cook delicate sauces or continue cooking covered foods. The ultra-low Melt setting is best for melting chocolate and butter.

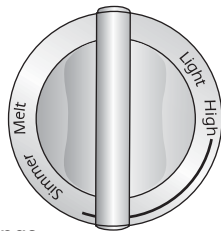

Important: When using the normal settings for preparing foods, it may take a few minutes for the cooking area to cool to the Melt heat setting.

* BTU ratings will vary when using LP gas.

Dual Ring Burner (select models)

The cooking surface is equipped with a dual ring burner located in the left front position. To operate, push in on the control knob and turn *counterclockwise* to light the burner. Continue turning until the desired setting is reached. The lighting sequence is: inner burner on High, then inner burner on Low, then both rings on High, then both rings on Low.

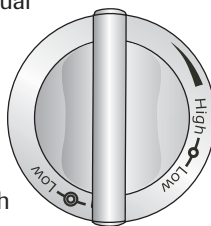

Burner Grates

The grates must be properly positioned *before* cooking. When installing the grates, place the tab ends toward the center, matching the straight bars.

Improper installation of the grates may result in chipping of the cooktop.

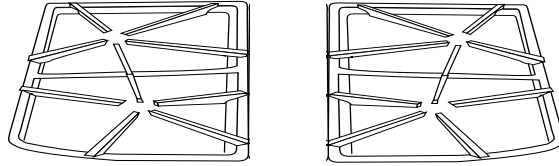

Do not operate the burners without a pan on the grate. The grate's porcelain finish may chip without a pan to absorb the heat from the burner flame.

Use care when stirring food in a pot/pan sitting on the burner grate. The grates have a smooth finish for ease of cleaning. The pot/pan will slide if the handle is not held. This may result in spilling of hot food items and may be a burn hazard.

Although the burner grates are durable, they will gradually lose their shine and/or discolor, due to the high temperatures of the gas flame.

Notes:

- A properly adjusted burner with clean ports will light within a few seconds. If using natural gas, the flame will be blue with a deeper blue inner cone.
If the burner flame is yellow or is noisy, the air/gas mixture may be incorrect. Contact a service technician to adjust. (Adjustments are not covered by the warranty.)
With LP gas, slight yellow tips on the flames are acceptable. This is normal and adjustment is not necessary.
- With some types of gas, you may hear a "popping" sound when the surface burner is turned off. This is a normal operating sound of the burner.
- If the control knob is turned very quickly from High to Low, the flame may go out, particularly if the burner is cold. If this occurs, turn the knob to the **OFF** position, wait several seconds and relight the burner.
- The flame should be adjusted so it does not extend beyond the edge of the pan.

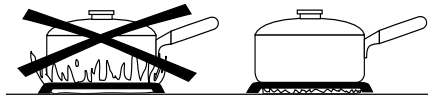

Use & Care

Ventilation System

The built-in ventilation system removes cooking vapors, odors and smoke from foods prepared on your cooktop and grill.

- To operate the ventilation system manually, push the **Vent Fan** pad located on the electronic control. Push *once* for **Low**, push *again* for **High** and a *third* time to turn the fan **Off**.

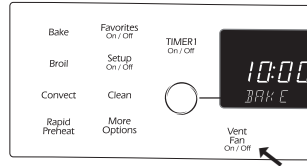

- The ventilation system will operate **automatically** when the grill element is in use.
- The fan can be used to remove strong odors from the kitchen as when chopping onions near the fan.

Care and Cleaning of the Ventilation System

- Air Grille:** The air grille lifts off easily. Wipe clean or wash in dishwasher or sink with mild household detergents. To prevent scratching the surface, **do not** use abrasive cleaners or scrubbing pads.

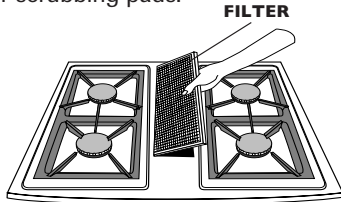

- Filter:** Turn off ventilation system *before* removing. The filter is a permanent type and should be cleaned when soiled. Clean in sink with warm water and detergent or in dishwasher.

IMPORTANT: DO NOT OPERATE SYSTEM WITHOUT FILTER. Filter should always be placed at an angle. As you face the front of the range, the top of the filter should rest against the left side of the vent opening. The bottom should rest against the right side of the vent chamber at the bottom. **Important: If filter is flat against the fan wall, ventilation effectiveness is reduced.**

- Ventilation Chamber:** This area, which houses the filter, should be cleaned in the event of spills or whenever it becomes coated with a film of grease. It can be cleaned with paper towel, damp cloth, or sponge and mild household detergent or cleanser.

Important: The oven vent is located under the right side of the air grille. When using or cleaning the oven, hot and moist air may be noticed in this area. The area near the vent may become hot enough to cause burns. Be careful not to spill anything into this vent. **The air grille must be removed before the self-clean cycle.**

OVEN COOKING

Control Panel

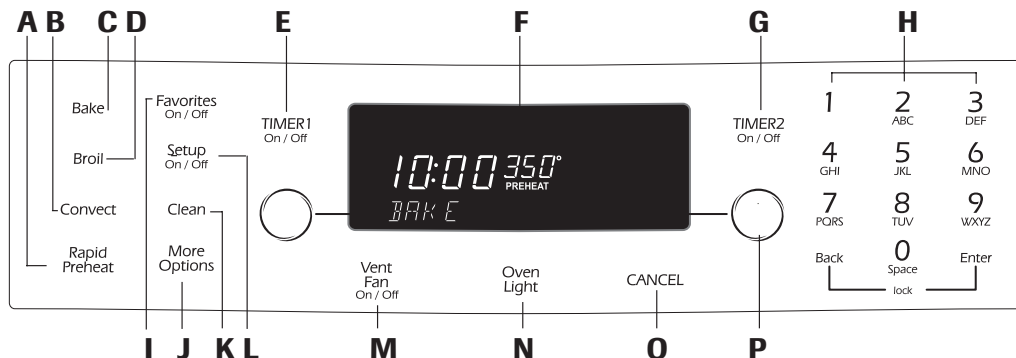

The control panel is designed for ease in programming. The display window shows options for each function and moves from step to step through the programming process. Control panel features vary by model. Oven display above is programmed for a bake operation.

A	Rapid Preheat	Use to decrease preheating time.
B	Convection	Use for convection baking and roasting.
C	Bake	Use for baking and roasting.
D	Broil	Use for broiling and top browning.
E	TIMER 1	Sets timer.
F	Display	Displays oven functions, options and window time of day.
G	TIMER 2	Sets timer.
H	Number Pads	Use to enter time and temperature, or to enter Favorites names.
I	Favorites	Use to access, program or save baking cycles.
J	More Options	Use to access additional features.
K	Clean	Use to set self-clean cycle.
L	Setup	Use to view or change factory default settings.
M	Vent Fan	Activates the ventilation fan on the cooktop.
N	Oven Light	Use to turn the oven light on or off.
O	CANCEL	Cancels all operations except Timer, Clock, Favorites, Setup and Vent Fan.
P	Quickset pads	Use to select options in display window (next to display window on both sides).

If you need to back out of a function or option in the display, press the **Back** pad. When your programming is complete, press the **Enter** pad or wait four seconds and the function will start automatically.

Up arrows indicate additional screens with additional options. Press the **Quickset** pads next to the arrows to scroll through the display.



Important: Four seconds after entering the function, option, number or letter, the function will automatically be entered. If more than 30 seconds elapse between steps in programming, the function will be canceled and the display will return to the previous display.

Clock Setting the Clock:

1. Press the **Setup** pad.
2. Select **CLOCK** using the Quickset pads.
3. Select **TIME**.
4. Enter the time using the number pads.
5. Press **Enter** pad.
6. Select **AM** or **PM** in 12 hour mode. (For 24 hour clock, see page 16.)
7. To exit the Setup mode, press **Setup** pad.

Setup
On / Off

Quickset Pads

Quickset pads are located on each side of the display window and are used to select the desired function or option in the display window. To select the option or function, press the **Quickset** pad next to the word.

Use & Care

Activating and canceling the clock/day of week display:

1. Press **Setup** pad.
2. Select **CLOCK**.
3. Press the arrow to scroll until DISABLE is displayed.
4. Select **DISABLE**.
5. Select **TIME**.
6. Select **OFF** to turn the clock display off, or select **ON** to turn the clock display on.
7. Select **OFF** to turn the day of the week display off. Select **ON** to turn the weekday display on.
8. To exit the Setup mode, press **Setup** pad.

Setup
On / Off

Entering the day of the week:

1. Press **Setup** pad.
2. Select **CLOCK**.
3. Press the arrow to scroll until DAY is displayed.
4. Use Quickset arrow to scroll through the days.
5. Select day desired.
6. To exit the Setup mode, press **Setup** pad.

Setup
On / Off

To set the clock for a 12 or 24 hour format:

The clock can be set to display time in either a 12 hour or 24 hour format.

1. Press the **Setup** pad.
2. Select **CLOCK**.
3. Use the arrow to scroll to the next screen.
4. Select **12/24 HOUR**.
5. Select **12 HR** or **24 HR**.
6. To exit Setup mode, press **Setup** pad.

Setup
On / Off

Timers

Setting the Timers (Timer 1 or Timer 2):

1. Press **TIMER 1** or **TIMER 2** pad.
2. Press one of the displayed times using the Quickset pads, or press the number pads to enter the desired time.

TIMER1
On / Off

Important: Each press of the displayed time choices adds additional time. For example, pressing "10 MIN" three times provides 30 minutes on the timer (0:30).

3. Press **Enter** pad.

Changing the amount of time entered once the Timer starts:

1. Press the **TIMER 1** or **TIMER 2** pad *once*.
2. Press the displayed times on the Quickset pads repeatedly until the desired time is entered.

TIMER1
On / Off

OR

3. Press the number pads to enter the new desired time.
4. Press **Enter** pad.

Canceling the Timer:

1. Press the **TIMER 1** or **TIMER 2** pad *twice*.

TIMER1
On / Off

If both Timers are active:

If the desired Timer is already in the foreground, press *once* for edit mode and *twice* to cancel the Timer. If the desired Timer is not in the foreground, follow the steps below.

1. Press the desired **TIMER** pad *once*. The selected Timer will come to the foreground.
2. Press the **TIMER** pad a *second* time to access the edit mode in order to make changes.
3. Pressing the **TIMER** pad a *third* time will cancel the Timer.

Changing the Timer beeps:

The signal beeps for **TIMER 1** and **TIMER 2** can be changed. The options available are two beeps every thirty seconds, two beeps every sixty seconds or one beep only. The default setting is one beep.

1. Press the **Setup** pad.
2. Select the arrow to scroll until **TONES** is displayed.
3. Select **TONES**.
4. Select **TIMERS TONES**.
5. Select the desired timer beep format (2-30 SEC, 2-60 SEC or 1 BEEP).
6. Press **Setup** pad to exit Setup mode.

Setup
On / Off

Locking the Control and Oven Door

The oven control and oven door can be locked to prevent accidental programming. If an oven function is currently being used, the control and door cannot be locked.

To lock the control and door:

Press the **Back** and **Enter** pads at the same time, holding for three seconds or until **CONTROL LOCKED** appears in the display.

To unlock the control and door:

Press the **Back** and **Enter** pads at the same time, holding for three seconds. **UNLOCKING DOOR** will appear in the display when the control and door are unlocking.

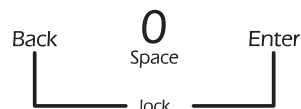

Use & Care

Baking

To set Bake:

1. Press the **Bake** pad.
2. Select the oven temperature using the Quickset pads.

Bake

OR

Enter the desired temperature using the number pads. Press **Enter** pad to set.

- The temperature can be set from 170° F to 550° F in 5° increments.
- After three seconds, the oven will begin to preheat. BAKE and PREHEAT will appear in the display along with 100° or the actual oven temperature, whichever is higher.



- The temperature in the display will increase in 1° increments until the oven reaches the preset temperature. Allow about 15 minutes for the oven to preheat.
 - When the oven is preheated, the oven will beep and PREHEAT will no longer be displayed.
3. At the end of cooking, turn the oven off by pressing the **CANCEL** pad. Remove food from the oven. The oven will continue operating until the CANCEL pad is pressed.

CANCEL

Notes:

- If more than thirty seconds elapse between pressing a pad and pressing a number pad, the display will return to the previous display.
- Whenever the temperature appears in the display, the oven is heating.
- To change the oven temperature during cooking, press the **Bake** pad and select a displayed temperature or use the number pads to enter the desired temperature.
- The oven will automatically shut off after 12 hours if it is accidentally left on. To set a Sabbath Mode, see *Sabbath Mode*, page 25.

Bake Options

Cook & Hold and Delay options are available when baking. When using the Cook & Hold option, the oven begins to heat immediately after the control has been set. Then, the oven cooks for a specified length of time. When that time has elapsed, the oven will automatically reduce temperature to 170° F and keep the food warm for up to an hour and then automatically turn off.

When using Delay, the oven begins to cook later in the day. Set the amount of time that you want to delay before the oven turns on and how long you want to cook. The oven begins to

heat at the selected time and cooks for the specified length of time. When that time has elapsed, the oven will keep the food warm for up to an hour then automatically turn off.

To set Cook & Hold:

1. After Bake has been programmed, press the **More Options** pad.
2. Select **COOK/HLD**.

More Options



3. Select the amount of time you want to bake by pressing the Quickset pads or the number pads.
4. Press **ENTER**.
5. COOK TIME, the cook time countdown, PREHEAT, BAKE and the actual temperature will be displayed.

The oven will cook for the selected time, then keep food warm for one hour.

To set a Delay:

1. After Bake has been programmed, press the **More Options** pad.
2. Select **DELAY**.
3. Select the amount of time you want to delay the start of cooking using the displayed times or the number pads.
4. Select the amount of time you want to cook using the displayed times or the number pads.
5. The display will show BAKE, the temperature, the delay time and the cook time countdown.
6. When the delay time has expired, the oven will begin heating. COOK TIME, the cook time countdown, PREHEAT, BAKE and the actual oven temperature will be displayed.

More Options

CAUTION

Do not use delayed baking for highly perishable foods such as dairy products, pork, poultry or seafood.

Convect

Convection uses a fan to circulate hot air evenly over, under and around the food. As a result, foods are evenly cooked and browned, often in shorter times, at lower temperatures and with the flexibility of using more than one rack at a time.

Convect Options

Cook & Hold and Delay options are available when convect cooking. See page 21 for information on how to program a Cook & Hold or Delay option.

CONVECT BAKE	CONVECT ROAST
Multiple-Rack Baking of Cookies/Biscuits Breads Casseroles	Whole Chicken Whole Turkey Vegetables Pork Roasts Beef Roasts Tarts/Tortes Cakes

Use & Care

Notes:

- The oven control comes from the factory set for Auto Convert Conversion. When using Convect Bake enter the *conventional* baking temperature. The control automatically converts the temperature to 25° less than the conventional temperature.
- When using Convect Roast the temperature will not be automatically reduced. Enter the *conventional* roasting temperature and time. The control then lets you know when 75% of the time has elapsed and alerts you to check the food for doneness.
- To turn Auto Convert Conversion off, see page 24.

Convect Bake

To set Convect Bake:

1. Press the **Convect** pad.
2. Select **CNVT BAKE** using the Quickset pads.

Convect



3. Select the oven temperature using the Quickset pads



OR

Enter the desired temperature using the number pads. Press **Enter** pad to set.

- The temperature can be set from 195° F to 550° F degrees in 5° increments.
 - After three seconds, the oven will begin to preheat. CNVT BAKE and PREHEAT will appear in the display along with 100° or the actual oven temperature, whichever is higher.
 - The temperature in the display will increase in 1° increments until the oven reaches the preset temperature. Allow about 15 minutes for the oven to preheat.
 - When the oven is preheated, the oven will beep, and PREHEAT will turn off and CNVT BAKE will be displayed. AUTO will be displayed if Auto Convert Conversion feature is turned on.
 - Place food in the oven.
4. At the end of cooking, turn the oven off by pressing the **CANCEL** pad. Remove food from the oven. The oven will continue operating until the CANCEL pad is pressed.

Convect Roast

To set Convect Roast:

1. Place food in the oven.
2. Press the **Convect** pad.

3. Select **CNVT ROAST** using the Quickset pads.



4. Select the oven temperature using the Quickset pads.

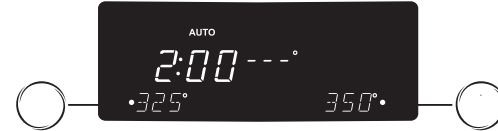

OR

Enter the desired temperature using the number pads. Press **Enter** pad to set.

- The temperature can be set from 195° F to 550° F degrees in 5° increments. If Auto Convert Conversion is turned off, you can set 170° F.
5. Enter desired cook time. Enter the conventional roasting time using the number pads.
 - After three seconds, the oven will begin to heat. CNVT ROAST will appear in the display along with 100° or the actual oven temperature, whichever is higher.
 - The temperature in the display will increase in 1° increments until the oven reaches the preset temperature.
 - Cook time will begin to count down.
 6. At 75% of the cooking time the oven will beep to let you know to check food. Check food using a meat thermometer. If food is done, take food out of oven and press **CANCEL** pad to turn oven off.
 7. If food is not done, continue roasting.

Once the set time has elapsed the oven will automatically go into Keep Warm mode for 1 hour. If food is taken from the oven before the hour has elapsed, press **CANCEL** pad.

CANCEL

Notes:

- If the recipe suggests preheating the oven, add time to cook time.
- If Auto is off, roast time will not be required.

Rapid Preheat

Use to decrease preheating time when using Bake or Convect Bake. Use for all foods when baking on one rack.

- After Bake or Convect Bake has been programmed and activated, press the **Rapid Preheat** pad.
- 1 RACK ONLY will display, after 10 seconds the display will show RAPID and PREHEAT.

To return to Standard Preheat:

- Press **Rapid Preheat** pad again. This will provide standard preheat and PREHEAT and the selected function will be displayed.

Cont.

Use & Care

Notes:

- For best results, use rack position 2 or 3 when using the Rapid Preheat option.
- For optimum baking and browning results, Rapid Preheat is not recommended when baking on multiple racks.

Broil

For optimal results, preheat for five minutes with the door closed and use a pan designed for broiling. Oven door should be open to the broil stop position (about 4 inches) when broiling.

To set Broil:

1. Place the oven rack in the proper rack position (see *Broiling Chart*).
2. Press the **Broil** pad.
3. Select **HIGH** – 550° F for high broil.



OR

Select **LOW** – 450° F for low broil.



- The oven has a variable broil feature which means that a lower broil temperature can be selected (300°-550° F). To select a lower temperature, press the appropriate number pads. Press **Enter** pad to set the lower temperature.

4. Preheat the oven for five minutes.
5. Place food in the oven and close the door to the broil stop position.
6. Press the **CANCEL** pad when broiling is done.



Notes:

- See *Broiling Chart* for foods and broiling times.
- If more than 30 seconds elapse between pressing the Broil pad, Quickset pads, or number pads, the oven will not be set and the display will return to the previous display.
- HIGH is used for most broiling. Use a lower broil temperature when broiling longer-cooking foods. The lower temperature allows food to cook to the well done stage without excessive browning.
- Expect broil times to increase and browning to be slightly lighter if the appliance is installed on a 208 volt circuit.
- Food should be turned halfway through broiling time.
- Broil times may be longer when lower broiling temperatures are selected.

Broiling Chart

FOODS	SUGGESTED BROIL TIME	RACK POSITION*
Beef (broiled to 165° F) 6 Hamburgers, 1/2" thick 2 Ribeye Steaks, 1" thick 2 New York Strip Steaks, 1" thick 2 T-Bone Steaks, 1" thick	10 – 12 minutes 18 – 22 minutes 18 – 22 minutes 18 – 22 minutes	4 4 4 4
Poultry (broiled to 170° F on Low) 4 Boneless/Skinless Breasts 4 Bone-In Chicken Breasts	Low Broil 12 – 15 minutes 20 – 33 minutes	4 3
Pork (broiled to 160° F) 4 Boneless Pork Chops, 1" thick 4 Bone-In Pork Chops, 1" thick Ham Slice, 1" thick	20 – 28 minutes 25 – 28 minutes 12 – 16 minutes	4 4 4
Fish (broiled to 140° F) 4 Swordfish Steaks, 1" thick 2 Halibut Steaks, 1" thick Orange Roughy, 1" thick Shrimp (16-20 ct. per lb.) 2 Salmon Fillets, 1/2" thick 2 Salmon Steaks, 1" thick	10 – 14 minutes 10 – 14 minutes 10 – 12 minutes 8 – 10 minutes 8 – 12 minutes 10 – 14 minutes	3 3 4 4 4 3

***Important:** To reduce browning and excess smoke when broiling, use a lower rack position and increase the broil time.

OPTIONS

More Options

Cook & Hold

1. Press the **More Options** pad.
2. Select **COOK/HOLD**.



More Options

3. Enter cook time using Quickset pads or the number pads.
4. Select **BAKE** or **CONVECT**.
5. When **BAKE** is pressed, select the temperature using Quickset pads or the number pads.
6. When **CONVECT** is pressed, select **CNVT BAKE** or **CNVT ROAST** then select the desired temperature using the Quickset pads or the number pads.

The oven will cook for the selected time, then Keep Warm for one hour. The oven will automatically turn off.

Important: If the recipe recommends preheating the oven, add 15 minutes to the cook time.

Delay

1. Press the **More Options** pad.
2. Press the arrow until **DELAY** is displayed.
3. Select **DELAY**.
4. Select Delay time using Quickset pads or the number pads.
5. Select **BAKE**, **CONVECT** or **CLEAN**, then select temperature using the Quickset or number pads.

More Options

To set Delay Bake:

1. Follow "Delay" steps 1-4 (see above).
2. Select from the displayed temperatures or use the number pads to enter the temperature.
3. Select the time to cook from the displayed times or use the number pads to enter the cooking time.
4. The display will show **DELAY TIME**, the selected function, the preset temperature and the delay time countdown. When the delay time has expired, the cook time will be displayed and the oven will begin to preheat.

To set Delay Convection:

1. Follow "Delay" steps 1-4 (see above).
2. Select **BAKE** or **ROAST**.
3. Select from the displayed temperatures or use the number pads to enter the temperature.
4. Select the time to cook from the displayed times or use the number pads to enter the cooking time.

5. The display will show **CONVECT DELAY**, the selected function, the preset temperature and the delay time countdown. When the delay time has expired, the cook time will be displayed and the oven will begin to preheat.

To set Delay Clean:

1. Follow "Delay" steps 1-4 (see below left).
2. **REMOVE RACKS** will show in the display. Remove the racks from the oven and select **CONTINUE**.
3. Set **LIGHT** soil level by entering 200 using the number pads for two hours of cleaning time. Select **MEDIUM** or **HEAVY** soil level using the Quickset pads. There is a brief delay while the door locks.
4. **DELAY CLEAN**, the cleaning time, the delay time and unlock time (based on the selected soil level) will show in the display. When the delay time has expired, the clean time will be displayed and the oven will begin to preheat.

For more information on self-cleaning, see pages 5-6.

CAUTION

Do not use delayed baking for highly perishable foods such as dairy products, pork, poultry, or seafood.

Proofing

The Proofing feature can be used to raise yeast-based bread products prior to baking. There are two proofing methods available – Rapid and Standard.

Standard proofing in the oven protects dough from room temperature changes or drafts that commonly affect proofing done on the countertop.

Rapid proofing provides faster proofing results than countertop or Standard proofing, without harming the yeast.

1. Press **More Options** pad.
2. Select **PROOFING**.
3. Select **RAPID** or **STANDARD**.
4. When proofing is complete, remove the dough from the oven and press the **CANCEL** pad.

More Options

CANCEL

Notes:

- For any dough that requires one rise, either Standard or Rapid Proofing can be used.
- When using frozen bread dough, choose **RAPID PROOFING**. There is no need to thaw dough before proofing.
- For dough requiring two rises, Standard Proofing must be used for the first rising period. Either Standard or Rapid Proofing can be used for the second rise.
- If oven temperature is too high for proofing, **OVEN COOLING** will appear in the display.

Use & Care

Keep Warm

The Keep Warm feature is used to safely keep hot foods warm or for warming breads and plates.

1. Press **More Options** pad.
2. Press the arrow to scroll.
3. Select **KEEP WARM**.

More Options



4. Select one of the displayed temperatures or enter desired temperature using the number pads. Temperatures can be selected between 145° and 190° F.
5. KEEP WARM and the temperature will be displayed.
6. When oven has preheated, a beep sounds and KEEP WARM and the temperature will be displayed.
7. When finished, press the **CANCEL** pad and remove food or plates from the oven.

CANCEL

To Warm Dinner Rolls:

- Cover rolls loosely with foil and place in oven.
- Press **More Options** pad.
- Select **KEEP WARM**.
- Select 170° temperature. Warm for 12-15 minutes.

To Warm Plates:

- Place two stacks of up to four plates each in the oven.
- Press **More Options** pad.
- Select **KEEP WARM**.
- Select 170° temperature.
- Warm for five minutes. Turn off the oven by pressing the **CANCEL** pad and leave plates in the oven for 15 minutes more.
- Use only oven-safe plates, check with the manufacturer.
- **Do not** set warm dishes on a cold surface as rapid temperature changes could cause crazing or breakage.

More Options

Notes:

- Food should be hot when placed in oven.
- For optimal food quality, foods should be kept warm for *no longer* than 1 hour.
- To keep foods from drying, cover loosely with foil or a glass lid.

Meat Probe

Using the probe supplied with your oven assures excellent roasting results every time.

1. Insert the probe into the food item. For meats, the probe tip should be located in the center of the thickest part of the meat and not into the fat or touching a bone.
2. Insert the probe plug into the receptacle located on the top right of the oven. Be sure to insert plug into the receptacle all the way.

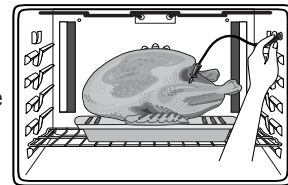

3. Press **More Options** pad.
4. Press the arrow to scroll.
5. Select **MEAT PROBE**.

More Options



6. Set the internal food temperature desired by selecting one of the displayed temperatures or enter the temperature using the number pads. The probe temperature can be set from 100° - 185° F. If the meat probe is not inserted, INSERT PROBE will be displayed.
7. Select **BAKE** or **CONVECT**.
8. Set the oven temperature by selecting one of the displayed temperatures or enter the temperature using the number pads.

Important: If the probe is removed from the oven receptacle at any time during the cooking process, the control will prompt INSERT PROBE. If the probe is not reinserted within 30 seconds, the program will be canceled and the oven will turn off.

When BAKE is selected:

- The display will briefly show the selected temperatures for the oven and probe.
- After 10 seconds, the display will show the actual oven temperature and actual probe temperature.

When CONVECT is selected:

- Select **CNVT BAKE** or **CNVT ROAST**.
- Set the oven temperature by selecting one of the displayed temperatures or enter the temperature using the number pads.
- The display will briefly show the selected temperatures for the oven and probe.
- After 10 seconds, the display will show the actual oven temperature and actual probe temperature.

Cont.

Use & Care

- When the selected internal temperature of the food has been reached, the oven will shut off and a beep will sound.
- Remove the probe from the oven receptacle. **The probe will be hot.** Hold probe plug with an oven mitt or potholder when removing from the oven.

Suggested Internal Food Temperatures

FOOD	INTERNAL TEMPERATURE	
Ground Beef	165° F	
Fresh Beef, Veal, Lamb	Medium Rare	145° F
	Medium	160° F
	Well Done	170° F
Chicken, Turkey	Whole	180° F
	Breast	170° F
Pork	Medium	160° F
	Well Done	170° F
	Ham, Precooked	140° F

Notes:

- The probe must be removed from the oven when it is not being used.
- Because of the excellent insulation of the oven, the retained heat continues to cook the food after the beep has sounded and the oven has turned off. For this reason, it is important to remove the food from the oven as soon as the beep sounds.
- Use the handle of the probe for inserting or removing. **Do not pull on the cable.**
- The probe is hot after cooking** – use a potholder or oven mitt to remove.
- To clean cooled probe, wipe with a soapy dishcloth. **Do not submerge probe in water or wash in dishwasher.**

FAVORITES

Favorites

Favorites stores the oven mode, cook time and temperature for up to 10 of your favorite recipes. Convection ovens come with five preprogrammed recipes.

To select a recipe from the preset Recipe List:

- Press **Favorites** pad.
- Select **RECIPE LIST**.
- Select desired recipe on screen or press arrow key to scroll to the desired recipe.
- Once the recipe is selected, oven will begin preheating to

Favorites
On / Off



the set program.

- You may press the **More Options** pad to add COOK/HOLD or DELAY.
- When finished, press the **CANCEL** pad and remove food from the oven.

To Save the Last Recipe Completed:

(Bake, Convection Bake, Convection Roast, Broil, Keep Warm)

- Press **Favorites** pad.
- Select **SAVE LAST**.
- Enter the name using the keypads.

Favorites
On / Off

- For example, to save lasagna, press the <JKL> pad *three* times for “L”; Press the <ABC> pad *once* for “A”; press the <STU> pad *once* for “S”. Continue until you’ve finished the word.
- After each desired letter appears, wait three seconds or press **Enter** pad *before* moving on the next letter.
 - Up to 14 letters including spaces can be used.
- When the recipe name has been entered, the last settings will be displayed for a few seconds.
- RECIPE LIST will then be displayed to scroll through the list.
- Press **Favorites** pad to exit the Favorites menu.

To Create a New Favorite Recipe:

- Press **Favorites** pad.
- Press arrow key to scroll through selections.
- Select **CREATE NEW** with touchpad on left.
- Enter the name using the keypads.
 - For example, to save lasagna, press the <JKL> pad *three* times for “L”; Press the <ABC> pad *once* for “A”; press the <STU> pad *once* for “S”. Continue until you’ve finished the word.
 - After each desired letter wait three seconds until an underline appears in the next space or press **Enter** pad *before* moving on the next letter.
 - Up to 14 letters including spaces can be used.

Favorites
On / Off

Use & Care

5. Select **ENTER** to save name.
6. Select cooking mode, such as **BAKE, CONVECT BAKE, CONVECT ROAST**, etc.
7. Select the oven temperature using the Quickset pads.

OR

- Enter the desired temperature using the number pads.
8. Add Cook/Hold by selecting **YES** or omit Cook/Hold by selecting **NO**.
 9. If you selected YES, enter cook time using the Quickset pads or the number pads.
 10. Add Delay by selecting **YES** or omit Delay by selecting **NO**.
 11. If you selected YES, enter the delay time by using the Quickset pads or the number pads.
 12. The control will display programmed settings then return to the Favorites menu.
 13. Press **Favorites** pad to exit the Favorites menu.

To Edit a Saved Recipe:

1. Press **Favorites** pad.

Favorites
On / Off

2. Press arrow key to scroll.
3. Select **EDIT RECIPE**.
4. Select desired recipe to edit. You may need to press arrow key to find desired recipe.
5. Follow menu to revise recipe settings as desired.
6. The display will return to the Favorites menu. RECIPE LIST will be displayed.
7. Press **Favorites** pad to exit Favorites menu.

To Delete a Favorite Recipe:

1. Press **Favorites** pad.
2. Press arrow key to scroll.
3. Select **DELETE RECIPE**.
4. Find recipe to be deleted. You may need to press arrow key to find desired recipe.
5. The Control will ask again to make sure you want to delete that recipe. Select **YES** or **NO**.
6. Press **Favorites** pad to exit Favorites menu.

To exit out of Favorites at any time, press the **Favorites** pad.

Favorites
On / Off

SETUP

Setup

1. Press the **Setup** pad.
2. Use the arrow to scroll through the Setup options.
3. Select the desired option by pressing the Quickset pads.

Setup
On / Off



Note: To back out of a screen without making any changes, press the **Setup** pad. The display will return to the time of day.

Clock

See pages 15-16 for more details. Use the Clock option to:

- Set the time of day.
- Set day of week.
- Select **AM** or **PM** (12-hour mode only). AM or PM will not show with the time of day in the display.
- Choose a 12 or 24 hour clock display.
- Disable the clock display.

Language

The language of the screens in the display window can be set to English, French or Spanish. To change the display language from English:

1. Press **Setup** pad.
2. Select **LANGUAGE**.
3. Use the arrow to scroll to next screen, if needed.
4. Select the desired language.
5. Press **Setup** pad to exit the Setup menu.

Setup
On / Off

Auto Convect Conversion

The oven comes from the factory set for Auto Convect Conversion.

Auto Convect Conversion automatically reduces the set temperature by 25° for Convect Bake.

For Convect Roast the control will alert you at 75% of the programmed roasting time to check foods for doneness. Convect roast temperatures are not reduced.

To deactivate Auto Convect Conversion:

1. Press **Setup** pad.
2. Select **AUTO CONVECT**.
3. Select **OFF**.
4. Press **Setup** pad to exit the Setup menu.

Setup
On / Off

Cont.

Use & Care

To reactivate Auto Convect Conversion:

1. Press **Setup** pad.
2. Select **AUTO CONVECT**.
3. Select **ON**.
4. Press **Setup** pad to exit the Setup menu.

Setup
On / Off

Notes:

- When using Convect Bake and Convect Pastry with the Auto Convect Conversion option turned off, reduce the set temperature by 25° F.
- If Convect Roasting with the Auto Convect Conversion option turned off, you will not be required to program a cooking time. Check food at 75% of the conventional time.

C/F

The displayed temperature scale can be changed from Fahrenheit to Celsius.

To change the scale:

1. Press **Setup** pad.
2. Use the arrow to scroll to the next screen.
3. Select **C/F**.
4. Select the desired temperature scale.
5. Press **Setup** pad to exit the Setup menu.

Setup
On / Off

Sabbath Mode

The oven is set to shut off after 12 hours if you accidentally leave it on. The Sabbath Mode overrides the 12-hour shut-off and can either be set to come on automatically or can be set manually as desired.

Only Bake or Cook/Hold Bake will operate when the oven is in Sabbath Mode. All other functions are invalid. If a function other than Bake or Cook/Hold Bake is in operation when Sabbath Mode starts, the function will be canceled.

To activate Sabbath Mode:

1. Press **Setup** pad.
2. Press the arrow to scroll.
3. Select **SABBATH**.
4. Select **AUTO** or **MANUAL**.

Setup
On / Off

- **AUTO** will automatically prompt you to enter a Bake temperature on Friday at 2 pm and stay in Sabbath mode for 33 hours. **SABBATH** and **SABBATH ENABLE** appear in the display for 90 minutes. If Bake or Cook/Hold Bake are desired during Sabbath Mode, they must be programmed during this 90 minute time *before* **AUTO** Sabbath Mode is active.
- **MANUAL** sets the oven to Sabbath Mode for 72 hours. **SABBATH** and **SABBATH ENABLE** appear in the display for five minutes. If Bake or Cook/Hold Bake are desired during Sabbath Mode, they must be programmed during this five minute time *before* the **MANUAL** Sabbath Mode is active.

5. Select **ON** or **OFF**.
6. Press **Setup** pad to exit the Setup menu.

To cancel Sabbath Mode:

Press and hold the **Setup** pad for five seconds. The Bake mode may be cancelled by pressing the **CANCEL** pad during Sabbath.

Setup
On / Off

Notes:

- The oven must be idle to program Sabbath Mode.
- Sabbath Mode cannot be turned on if the keypads are locked out or when the door is locked.
- If the oven is baking when Auto Sabbath Mode starts, there will be no audible beeps.
- All prompts, messages and beeps are deactivated when the Sabbath Mode is active.
- If the oven light is desired while in Sabbath Mode, it must be turned on *before* the Sabbath Mode is set.
- The self-clean cycle and automatic door lock do not operate during the Sabbath Mode.
- The Bake temperature can be changed during an Active Sabbath Mode. Simply press the **Bake** pad and then enter the desired temperature using the Quick set pads.
- Pressing the **CANCEL** pad will cancel a Bake cycle, however the control will stay in the Sabbath Mode.
- The day of the week and AM/PM must be set for Sabbath Mode to operate correctly.

Temp Adjust

Oven temperatures are carefully tested at the factory. It is normal to notice some baking time or browning differences between a new oven and an old one. As ovens get older, the oven temperature can shift.

You may adjust the oven temperature if you think the oven is not baking or browning correctly. To decide how much to change the temperature, set the oven temperature 25° F higher or lower than the temperature in your recipes, then bake. The results of the first bake should give you an idea of how much to adjust the temperature.

To adjust the oven temperature:

1. Press **Setup** pad.
2. Press the arrow to scroll.
3. Select **TEMP ADJUST**.
4. Enter the desired temperature change using the number pads.
5. Select **“+/-”** to indicate an increase or decrease in temperature. The temperature change is displayed at the top of the window.
6. Press **Enter** pad or wait three seconds to accept the change.
7. Press **Setup** pad to exit the menu.

Setup
On / Off

The oven temperature does not need to be readjusted if there is a power failure or interruption.

Broiling and cleaning temperatures cannot be adjusted.

Use & Care

Tones (beeps)

The number of beeps heard at the end of cooking and at the end of timer operation and their volume can be adjusted.

To adjust the beeps:

1. Press **Setup** pad.
2. Use the arrow to scroll.
3. Select **TONES**.

Setup
On / Off

To change the beeps at the end of cooking:

1. Follow “Tones” steps 1-3 (see above).
2. Select **COOK TONE**.
3. Use the arrow to scroll.
4. Select **1-30 MIN** to hear one beep every thirty seconds.

OR

Select **1-60 MIN** to hear one beep every sixty seconds.

OR

Select **1 BEEP** to hear one beep only at the end of cooking.

5. Press the **Setup** pad to exit.

To change the timer beeps:

1. Follow “Tones” steps 1-3 (see above).
2. Select **TIMERS TONES**.
3. Use the arrow to scroll.
4. Select **2-30 SEC** to hear two beeps every thirty seconds.

OR

Select **2-60 SEC** to hear two beeps every sixty seconds.

OR

Select **1 BEEP** to hear one beep only at the end of the set time.

5. Press the **Setup** pad to exit.

Setup
On / Off

To change the volume of the beeps:

1. Follow “Tones” steps 1-3 (see above).
2. Press the arrow to scroll.
3. Select **VOLUME**.
4. Select **HIGH** for the highest volume.

OR

Select **MEDIUM** for medium volume.

OR

Select **LOW** for the lowest volume.

5. Press the **Setup** pad to exit.

12 HR Shutoff

The oven will automatically turn off at the end of 12 hours if you accidentally leave it on.

To turn off this feature:

1. Press **Setup** pad.
2. Use the arrow to scroll.

Setup
On / Off

3. Select **12HR SHUTOFF**.
3. Select **ON** or **OFF** using the Quickset pads.
4. Press the **Setup** pad to exit.

Energy Saver

To save energy, the display can be set to go dark if it is not being used.

To set the Energy Saver feature:

1. Press **Setup** pad.
2. Use the arrow to scroll.
3. Select **ENERGY SAVER**.
4. Select **ON** or **OFF** using the Quickset pads.
5. Press the **Setup** pad to exit.

Press any pad to “wake up” the display.

Setup
On / Off

Service

This area of the oven control displays the Jenn-Air Customer Service toll-free phone number.

1. Press **Setup** pad.
2. Use the arrow to scroll.
3. Select **SERVICE**.
4. Press the **Setup** pad to exit.

Setup
On / Off

Demo

When Demo is selected, you will see a short presentation highlighting the features of your new Jenn-Air range.

1. Press **Setup** pad.
2. Use the arrow to scroll.
3. Select **DEMO**.
4. Select **ON** or **OFF** using the Quickset pads.
5. Press the **Setup** pad to exit.

Setup
On / Off

Appendix C

Gas Conversion Instructions, JGS8750BD*

Part No. 8101P684-60

LP Propane Conversion Instructions



Instructions de conversion au GPL/ Instrucciones de conversión a gas LP propano

• Only qualified personnel should convert this range./Seul un personnel qualifié doit procéder à la conversion de cette cuisinière./La estufa sólo debe ser convertida por personal calificado. • Retain natural orifices for future conversion./Conservez les gicleurs pour gaz naturel pour une conversion ultérieure./Guarde los orificios de gas natural para una conversión futura. • Reverse this procedure for LP to natural gas conversion./Procédez inversement pour la conversion du GPL au gaz naturel./Invierta este procedimiento para convertir el producto de gas LP a gas natural.

This range is equipped with fixed orifices on all burners and a convertible appliance regulator. The unit serial plate states which gas it was adjusted for at the factory. To convert the unit to either Natural gas or LP gas will require replacement of the oven orifice hoods, and the top burner orifice hoods, and adjustment of the oven burner shutters and the appliance pressure regulator converter cap.

Cette cuisinière est équipée de gicleurs fixes sur tous les brûleurs et d'un détendeur convertible. La plaque signalétique de cet appareil indique le réglage fait à l'usine pour un certain gaz. La conversion de l'appareil au gaz naturel ou au GPL nécessite le remplacement des têtes de gicleur du four et des têtes de gicleur du brûleur supérieur, ainsi que le réglage des obturateurs de brûleur du four et du capuchon du convertisseur du détendeur.

Esta estufa viene equipada con orificios fijos en todos los quemadores y con un regulador convertible para electrodomésticos. La placa de serie de la unidad indica para qué tipo de gas se calibró en la fábrica. Para convertir la unidad a gas natural o a gas LP es necesario reemplazar las caperuzas de los orificios del horno y los orificios de los quemadores superiores, además de ajustar los obturadores del quemador del horno y la tapa del convertidor del regulador de presión del electrodoméstico.

Inlet pressure to the appliance pressure regulator should be as follows for both operation and checking of appliance pressure regulator setting./La presión d'arrivée au détendeur de l'appareil doit être la suivante pour le fonctionnement et la vérification du réglage du détendeur ./La presión de entrada al regulador de presión debe ser la siguiente tanto para el funcionamiento normal como para verificar el ajuste del regulador de presión:

Inlet Pressure in inches of water column Pression d'arrivée en pouces à la colonne d'eau Presión de entrada en pulgadas c.d.a.	Natural Gas Gaz naturel Gas natural	LP Gas GPL Gas LP
Max/Max./Máx.	14 (36 cm)	14 (36 cm)
Min/Min./Mín.	6 (16 cm)	11 (28 cm)

1

Turn off gas and electrical supply to product.

Fermez le gaz et coupez l'électricité alimentant l'appareil.

Cierre el suministro de gas y desconecte el suministro eléctrico al producto.

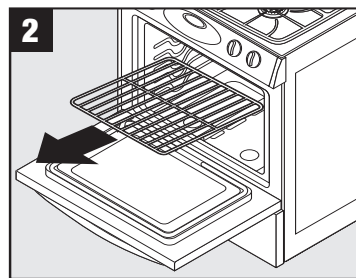

Remove oven rack./Retirez la grille du four./Retire la parrilla del horno.

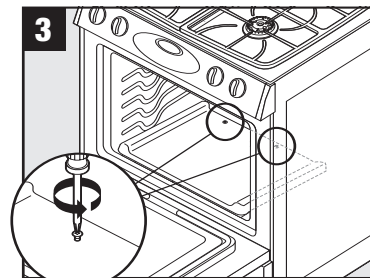

Remove oven bottom screws./Retirez les vis de la sole du four./Retire los tornillos inferiores del horno.

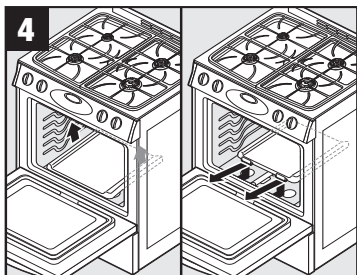

Lift up and remove oven bottom./Soulevez la sole du four et retirez-la./Levante y retire el fondo del horno.

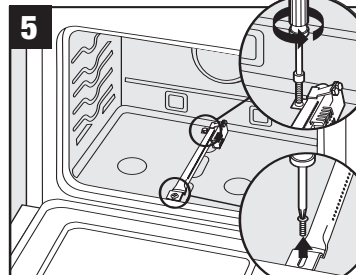

Remove bake burner screws./Retirez les vis du brûleur de cuisson au four./Retire los tornillos del quemador de horneado.

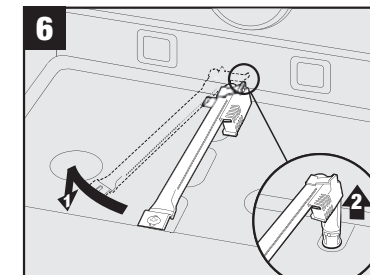

Swing bake burner to the side and lift bake burner off the oven orifice./Pivotez le brûleur de cuisson sur le côté et soulevez-le pour le séparer de son gicleur./Gire el quemador del horno a un lado y levántelo para sacarlo del orificio.

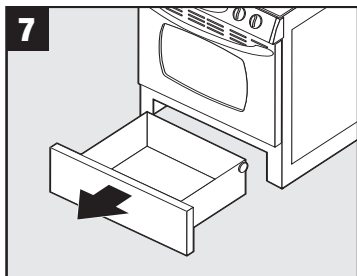

Remove storage drawer./Retirez le tiroir de rangement./Retire el cajón de almacenamiento.

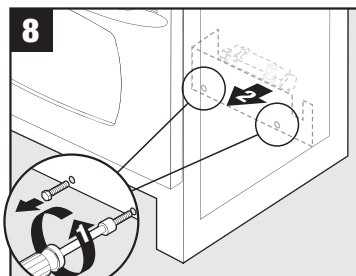

Remove screws from panel and then remove panel./Retirez les vis du panneau puis le panneau lui-même./Retire los tornillos del panel y retire el panel.

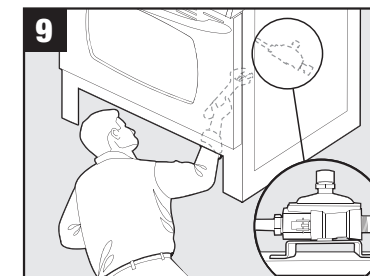

Locate regulator from the front./Repérez le détendeur à l'avant./Ubique el regulador desde la parte delantera.

Note: Your range may not be equipped with some of the features referred to in this manual./Remarque: Votre cuisinière peut ne pas comporter certaines des caractéristiques mentionnées dans ce manuel./Nota: Es posible que esta estufa no venga equipada con todas las características que se indican en este manual.

Gas Conversion Instructions, JGS8750BD*

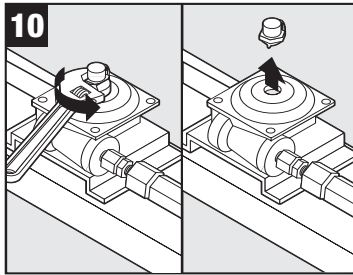

10 Unscrew the regulator cap./Dévissez le capuchon du détendeur./Desenrosque la tapa del regulador.

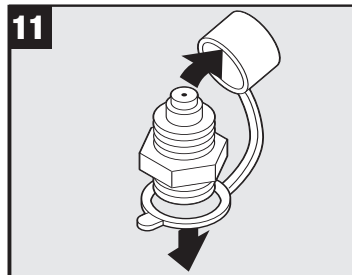

11 Remove the plastic cap./Retirez le capuchon en plastique./Retire la tapa de plástico.

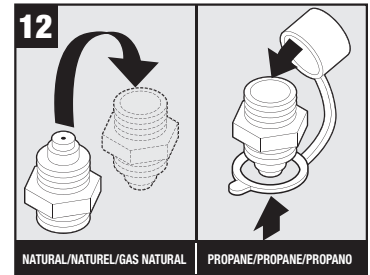

12 Flip the regulator cap and replace the plastic cap./Abattez le capuchon du détendeur et installez le capuchon en plastique./Invierta la tapa del regulador y vuelva a colocar la tapa de plástico.

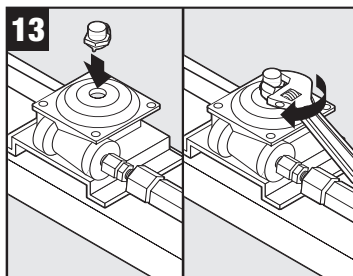

13 Screw the cap securely back into place. DO NOT OVERTIGHTEN./ Revissez bien le chapeau. NE LE SERREZ PAS TROP FORT./ Enrosque la tapa firmemente en su lugar. NO APRIETE DEMASIADO.

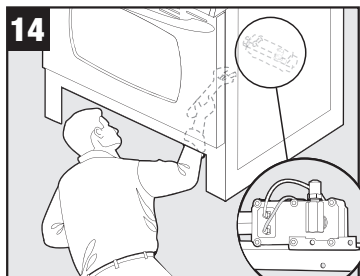

14 Locate oven orifice hood from the front./Identifiez la tête de gicleur du four par l'avant./Ubique la caperuza del orificio del quemador del horno desde la parte delantera.

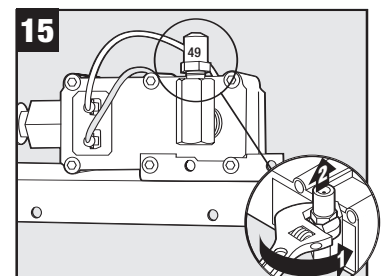

15 Remove #49 natural oven orifice hood./Retirez la tête de gicleur du four n° 49 pour gaz naturel./Retire la caperuza del orificio de gas natural #49 del horno.

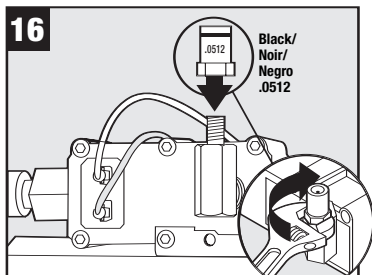

16 Install black .0512 LP orifice hood. (4-5 turns-DO NOT OVERTIGHTEN)/Installez la tête de gicleur noire .0512 pour GPL. (4-5 tours – NE SERREZ PAS TROP FORT)/Instale la caperuza negra de 0,0512 para gas LP del orificio del quemador. (4 a 5 vueltas – NO APRIETE DEMASIADO)

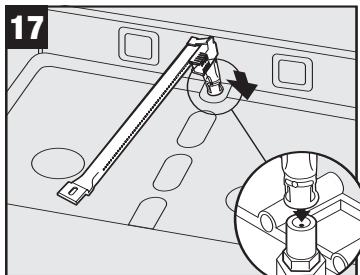

17 Position bake burner over bake orifice hood./Positionnez le brûleur de cuisson au-dessus de la tête de gicleur./Coloque el quemador del horno sobre la caperuza del orificio del quemador del horno.

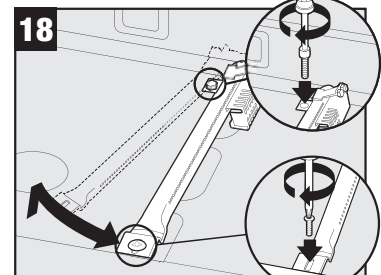

18 Reposition bake burner and replace/tighten bake burner screws./Repositionnez le brûleur de cuisson et remettez puis resserrez les vis du brûleur de cuisson./Cambie de posición el quemador del horno y vuelva a instalar/apretar los tornillos del quemador del horno.

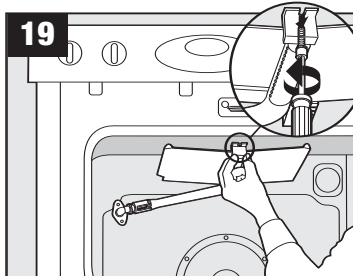

19 Remove broil burner screw./Enlevez la vis du brûleur de grill./Retire el tornillo del quemador de asar.

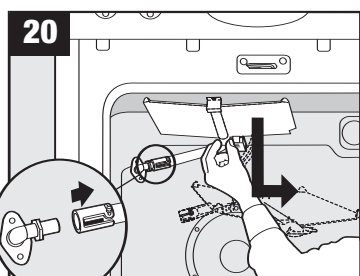

20 Slip the broil burner off the broil orifice hood./Sortez le brûleur de grill de la tête du gicleur de grill./Deslice el quemador de asar para sacarlo de la caperuza del orificio.

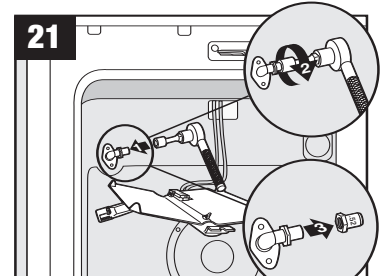

21 Remove #52 natural broil orifice hood./Retirez la tête du gicleur de grill n° 52 pour gaz naturel./Retire la caperuza del orificio de gas natural #52 del quemador de asar.

Gas Conversion Instructions, JGS8750BD*

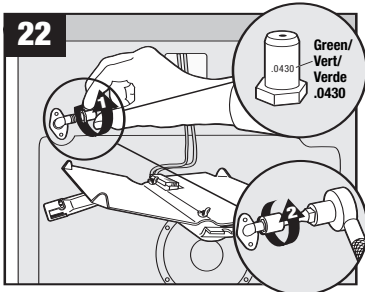

22 Install green .0430 LP broil orifice hood. (4-5 turns-DO NOT OVERTIGHTEN)/Installez la tête du gicleur de grill, verte .0430 pour GPL. (4 à 5 tours – NE SERREZ PAS TROP)/Instala la caperuza verde de 0,0430 para gas LP del orificio del quemador de asar. (4 a 5 vueltas – NO APRIETE DEMASIADO)

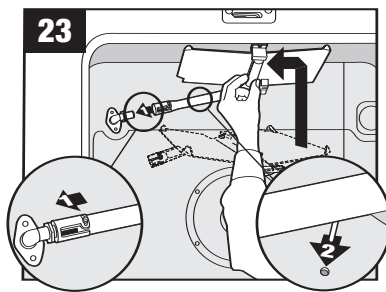

23 Place the broil burner on the broil orifice hood. CAUTION: Carefully insert burner pin in oven back./ Mettez le brûleur de grill sur la tête du gicleur de grill. ATTENTION : Insérez soigneusement le tenon du brûleur dans le four./Coloque el quemador de asar en la caperuza del orificio.PRECAUCIÓN: Inserte cuidadosamente el pasador en la parte trasera del horno.

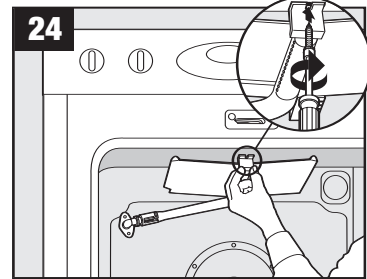

24 Reposition the broiler burner and tighten screw. Re-assemble oven. (See steps 2-4)/Remettez en place le brûleur de grill et serrez la vis. Remontez le four. (Voyez les étapes 2-4)/Vuelva a colocar el quemador de asar en su lugar y apriete el tornillo. Vuelva a ensamblar el horno. (Vea los pasos 2 al 4.)

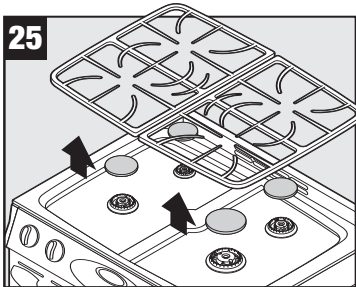

25 Remove the top grates. Remove the burner caps./Retirez les grilles supérieures. Retirez les chapeaux de brûleur./Retire las rejillas superiores. Retire las tapas de los quemadores.

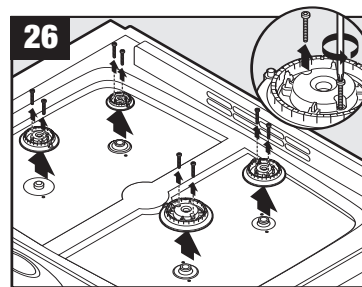

26 Remove screws and burner head./Retirez les vis et la tête de brûleur./Retire los tornillos y la cabeza del quemador.

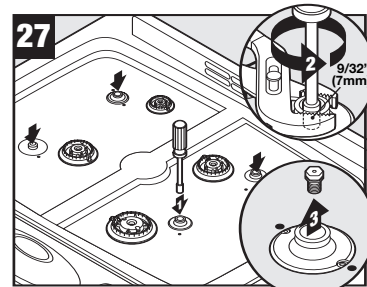

27 Carefully remove gas orifice hoods and convert one burner at a time./Enlevez soigneusement les têtes de gicleur pour gaz naturel et convertissez un brûleur à la fois./Retire cuidadosamente las caperuzas de los orificios de gas y convierta un quemador a la vez.

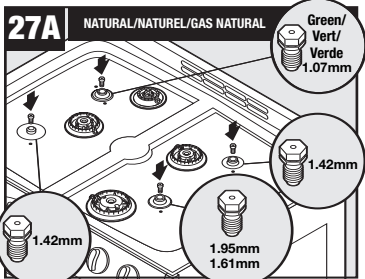

27A NATURAL/NATUREL/GAS NATURAL. IMPORTANT: Keep old natural gas orifice hoods./IMPORTANT: Conservez les anciennes têtes de gicleur pour gaz naturel./IMPORTANTE: Conserve las caperuzas usadas de los orificios de gas natural.

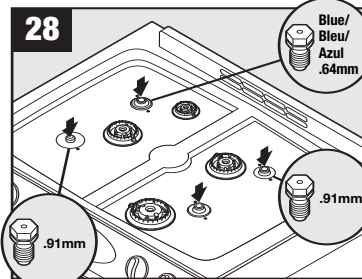

28 Replace with LP gas orifice hoods. DO NOT OVERTIGHTEN./Remplacez-les avec des têtes de gicleur pour GPL. NE SERREZ PAS TROP./Reemplácelas con caperuzas de orificios de gas LP. NO APRIETE DEMASIADO.

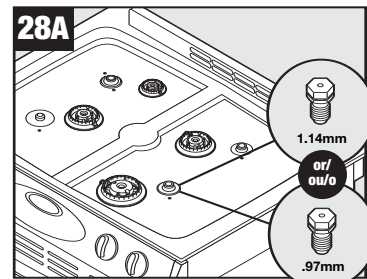

28A Replace with LP gas orifice hood. (1.95 black—replace with 1.14 red or 1.61 no color—replace with .97 green.) DO NOT OVERTIGHTEN./Remplacez par une tête de gicleur pour GPL. (Noir 1.95 : remplacez par rouge 1.14. Sans couleur 1.61 : remplacez par vert .97.) NE SERREZ PAS TROP./Reemplácela con una caperuza de orificios de gas LP. (1,95 negro—reemplace con 1,14 rojo, o 1,61 sin color—reemplace con 0,97 verde.) NO APRIETE DEMASIADO.

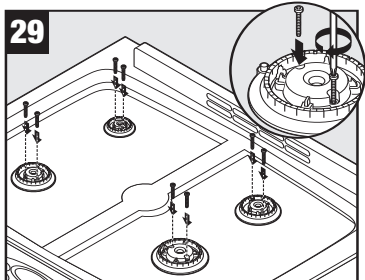

29 Remount burner heads and replace screws. (Hand tighten)/Réinstallez les têtes de brûleur et remettez les vis. (Serrez-les à la main.)/Vuelva a instalar las cabezas de los quemadores y vuelva a colocar los tornillos. (Apriete a mano).

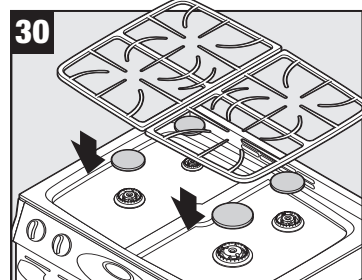

30 Replace burner caps. Replace grates./Remettez les chapeaux de brûleur. Remettez les grilles./Vuelva a instalar las tapas de los quemadores. Vuelva a instalar las rejillas.

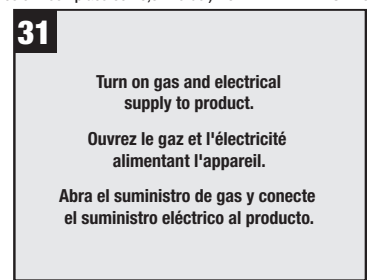

31 Turn on gas and electrical supply to product.
Ouvrez le gaz et l'électricité alimentant l'appareil.
Abra el suministro de gas y conecte el suministro eléctrico al producto.

Gas Conversion Instructions, JGS8750BD*

Low Flow Adjustment/Réglage bas débit/Ajuste del flujo mínimo

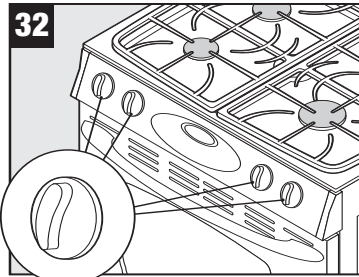

NOTE: Repeat steps 33-37 for all burners.
RMARQUE: Répétez les étapes 33 à 37 pour tous les brûleurs.
NOTA: Repita los pasos 33 al 37 para todos los quemadores.

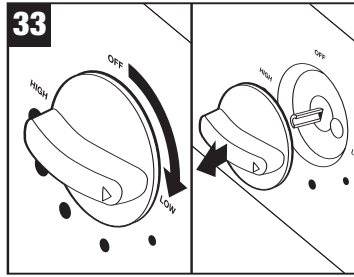

Adjust each surface burner one at a time. Light burner and turn to lowest setting. Remove knob./Ajustez chaque brûleur de surface un par un. Allumez le brûleur et réglez-le au niveau le plus bas. Enlevez le bouton./Ajuste los quemadores superiores uno a la vez. Encienda el quemador y ajústelo al nivel más bajo. Retire la perilla.

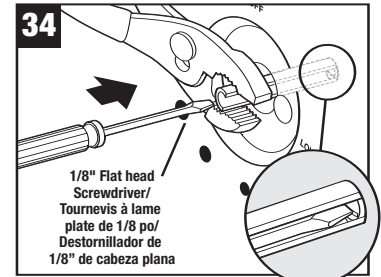

Hold knob stem in LOW position. Insert screwdriver to engage screw./Tenez la tige du bouton en position LOW. Introduisez le tournevis pour tourner la vis./Mantenga la varilla de la perilla en el ajuste 'LOW' (Bajo). Inserte el destornillador en el tornillo.

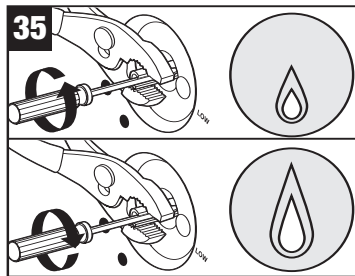

Adjust flame height with screwdriver./Ajustez la hauteur de la flamme avec le tournevis./Ajuste la altura de la llama con el destornillador.

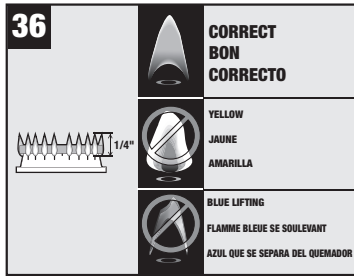

Correct flame height and appearance./Flamme de hauteur et d'aspect appropriés./Altura y apariencia correctas de la llama.

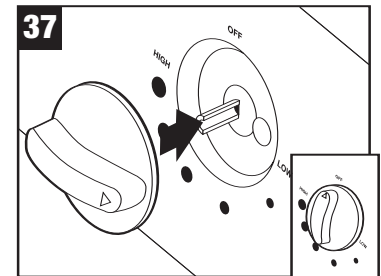

Replace knobs. Turn OFF burners./Remettez les boutons. Mettez les brûleurs sur OFF (ARRÊT)/Vuelva a instalar las perillas. APAGUE los quemadores.

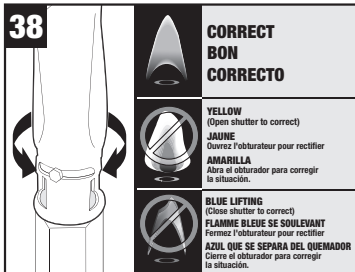

If necessary, adjust both oven burner shutters for correct flames. Secure shutter opening with screw./Au besoin, ajustez les deux obturateurs du brûleur du four pour obtenir les flammes appropriées. Fixez l'obturateur avec la vis./De ser necesario, ajuste ambos obturadores del quemador del horno para obtener la llama correcta. Fije la abertura del obturador con el tornillo.

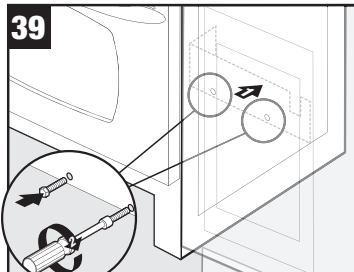

Replace panel and screws./Remettez le panneau et les vis./Vuelva a instalar el panel y los tornillos.

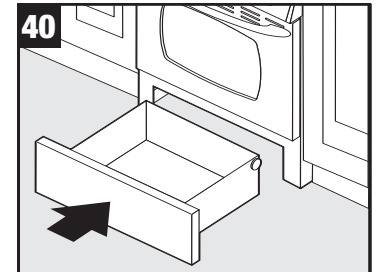

Replace storage drawer./Remettez le tiroir de rangement./Vuelva a instalar el cajón de almacenamiento.

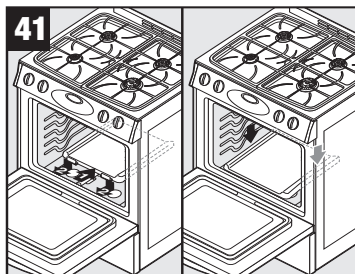

Replace oven bottom./Remettez le panneau inférieur du four./Vuelva a instalar el panel inferior del horno.

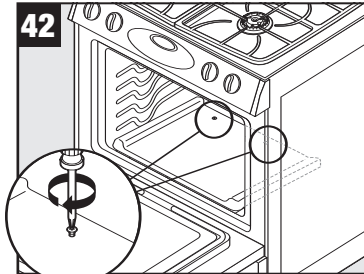

Replace oven bottom screws./Remettez les vis de la sole du four./Vuelva a instalar los tornillos inferiores del horno.

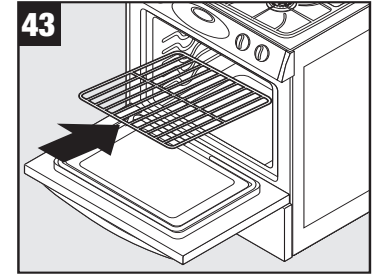

Replace oven rack./Remettez la grille de four./Vuelva a instalar la rejilla del horno.

Gas Conversion Instructions, JGS8850BD*, JGS8860BD*

Rev 1-1/06 Gas Updraft/Part No. 8101P724-60

LP Propane Conversion Instructions



Instructions de conversion au GPL/ Instrucciones de conversión a gas LP propano

• Only qualified personnel should convert this range./Seul un personnel qualifié doit procéder à la conversion de cette cuisinière./La estufa sólo debe ser convertida por personal calificado. • Retain natural orifices for future conversion./Conservez les gicleurs pour gaz naturel pour une conversion ultérieure./Guarda los orificios de gas natural para una conversión futura. • Reverse this procedure for LP to natural conversion./Procédez inversement pour la conversion du GPL au gaz naturel./Invierta este procedimiento para convertir el producto de gas LP a gas natural.

This range is equipped with fixed orifices on all burners and a convertible appliance regulator. The unit serial plate states which gas it was adjusted for at the factory. To convert the unit to either Natural gas or LP gas will require replacement of the oven orifice hoods, and the top burner orifice hoods, and adjustment of the oven burner shutters and the appliance pressure regulator converter cap.

Cette cuisinière est équipée de gicleurs fixes sur tous les brûleurs et d'un détendeur convertible. La plaque signalétique de cet appareil indique le réglage fait à l'usine pour un certain gaz. La conversion de l'appareil au gaz naturel ou au GPL nécessite le remplacement des têtes de gicleur du four et des têtes de gicleur du brûleur supérieur, ainsi que le réglage des obturateurs de brûleur du four et du capuchon du convertisseur du détendeur.

Esta estufa viene equipada con orificios fijos en todos los quemadores y con un regulador convertible para electrodomésticos. La placa de serie de la unidad indica para qué tipo de gas se calibró en la fábrica. Para convertir la unidad a gas natural o a gas LP es necesario reemplazar las caperuzas de los orificios del horno y los orificios de los quemadores superiores, además de ajustar los obturadores del quemador del horno y la tapa del convertidor del regulador de presión del electrodoméstico.

Inlet pressure to the appliance pressure regulator should be as follows for both operation and checking of appliance pressure regulator setting./La pression d'arrivée au détendeur de l'appareil doit être la suivante pour le fonctionnement et la vérification du réglage du détendeur./La presión de entrada al regulador de presión debe ser la siguiente tanto para el funcionamiento normal como para verificar el ajuste del regulador de presión:

Inlet Pressure in inches of water column Pression d'arrivée en pouces à la colonne d'eau Presión de entrada en pulgadas c.d.a.	Natural Gas Gaz naturel Gas natural	LP Gas GPL Gas LP
Max./Max./Máx.	14 (36 cm)	14 (36 cm)
Min./Min./Min.	6 (16 cm)	11 (28 cm)

1

Turn off gas and electrical supply to product.

Fermez le gaz et coupez l'électricité alimentant l'appareil.

Cierre el suministro de gas y desconecte el suministro eléctrico al producto.

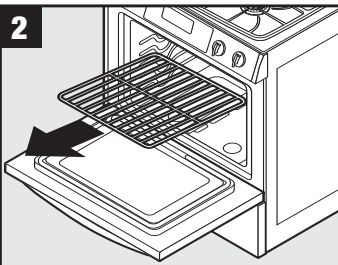

Remove oven rack./Retirez la grille du four./Retire la parrilla del horno.

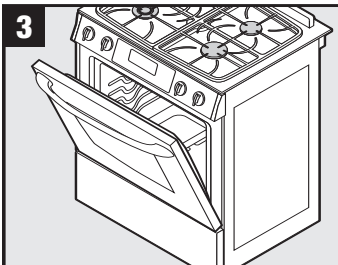

Open oven door to the first stop position./Ouvrez la porte du four jusqu'à la première position d'arrêt.
/Abra la puerta del horno hasta el primer tope.

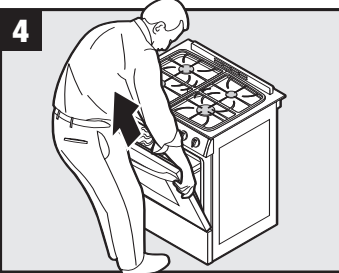

Remove oven door by holding both sides and pulling up./
Retirez la porte du four en la tenant par les deux côtés et en la tirant vers le haut./Retire la puerta del horno sosteniendo ambos lados y tirando de ella hacia arriba.

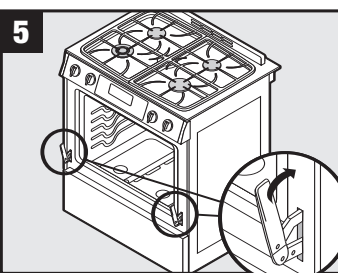

Move hinges to the closed position./Placez les charnières à la position fermée./Mueva las bisagras a la posición cerrada.

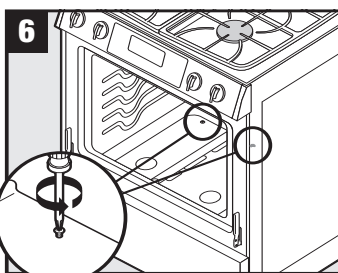

Remove oven bottom screws./Retirez les vis de la sole du four./Retire los tornillos inferiores del horno.

Note: Your range may not be equipped with some of the features referred to in this manual./**Remarque:** Votre cuisinière peut ne pas comporter certaines des caractéristiques mentionnées dans ce manuel./**Nota:** Es posible que esta estufa no venga equipada con todas las características que se indican en este manual.

Printed in USA

©2005 Maytag Corporation

Gas Conversion Instructions, JGS8850BD*, JGS8860BD*

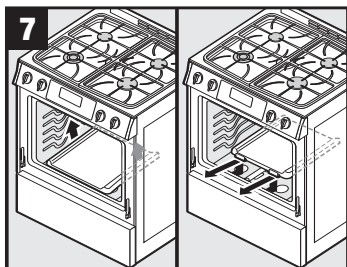

7 Lift up and remove oven bottom./Soulevez la sole du four et retirez-la./Levante y retire el fondo del horno.

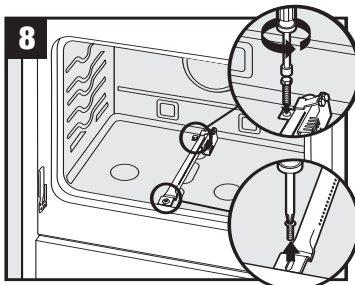

8 Remove bake burner screws./Retirez les vis du brûleur de cuisson au four./Retire los tornillos del quemador de horneado.

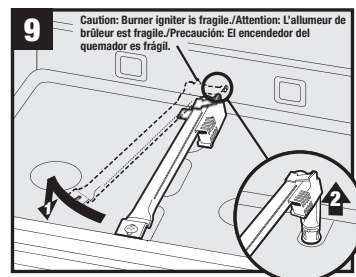

9 **Caution: Burner igniter is fragile./Attention: L'allumeur de brûleur est fragile./Precaución: El encendedor del quemador es frágil.** Swing bake burner to the side and lift bake burner off the oven orifice./Pivotez le brûleur de cuisson sur le côté et soulevez-le pour le séparer de son gicleur./Gire el quemador del horno a un lado y levántelo para sacarlo del orificio.

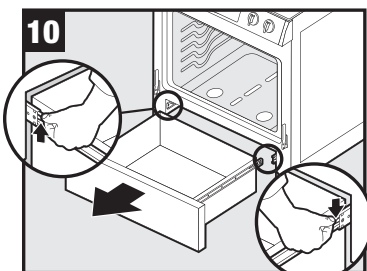

10 Remove warming drawer./Retirez le tiroir de réchauffage./Retire el cajón de calentamiento.

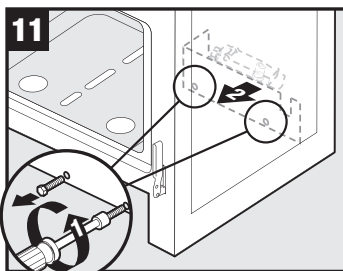

11 Remove screws from panel and then remove panel./Retirez les vis du panneau puis le panneau lui-même./Retire los tornillos del panel y retire el panel.

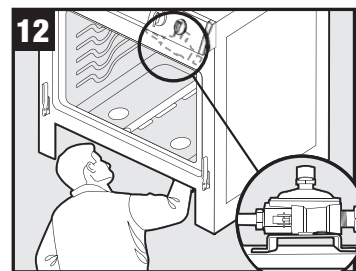

12 Locate regulator from the front./Repérez le détendeur à l'avant./Ubíque el regulador desde la parte delantera.

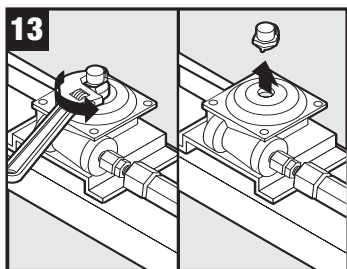

13 Unscrew the regulator cap./Dévissez le capuchon du détendeur./Desenrosque la tapa del regulador.

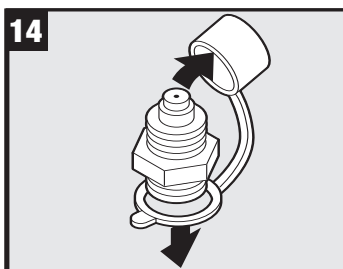

14 Remove the plastic cap./Retirez le capuchon en plastique./Retire la tapa de plástico.

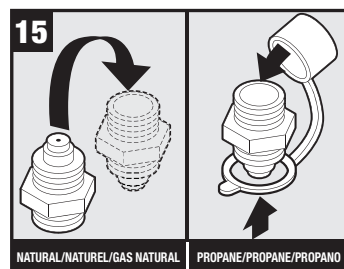

15 Flip the regulator cap and replace the plastic cap./Abattez le capuchon du détendeur et installez le capuchon en plastique./Invierta la tapa del regulador y vuelva a colocar la tapa de plástico.

Gas Conversion Instructions, JGS8850BD*, JGS8860BD*

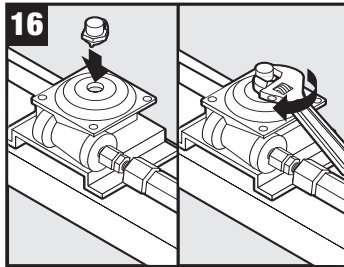

16
Screw the cap securely back into place. DO NOT OVER TIGHTEN./ Revissez bien le chapeau. NE LE SERREZ PAS TROP FORT./ Enrosque la tapa firmemente en su lugar. NO APRIETE DEMASIADO.

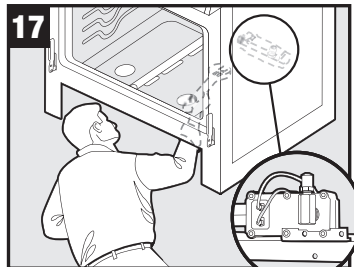

17
Locate oven orifice hood from the front./Identifiez la tête de gicleur du four par l'avant./Ubique la caperuza del orificio del quemador del horno desde la parte delantera.

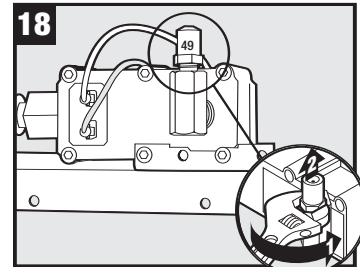

18
Remove #49 natural oven orifice hood./Retirez la tête de gicleur du four n° 49 pour gaz naturel./Retire la caperuza del orificio de gas natural #49 del horno.

You MUST start bake and broil hoods by hand to avoid cross threading.

Vous DEVEZ faire démarrer les têtes de gicleur de cuisson et de gril à la main afin d'éviter qu'un filetage ne soit faussé.

Usted DEBE iniciar el enrosado de las tapas de horneado y asado a mano para evitar dañar las roscas.

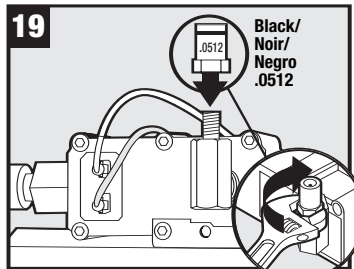

19
Install black .0512 LP orifice hood. DO NOT OVERTIGHTEN./Installez la tête de gicleur noire .0512 pour GPL. NE SERREZ PAS TROP FORT./Instale la caperuza negra de 0,0512 para gas LP del orificio del quemador. NO APRIETE DEMASIADO.

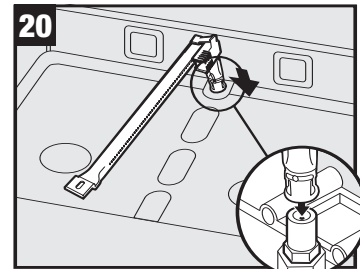

20
Position bake burner over bake orifice hood./Positionnez le brûleur de cuisson au-dessus de la tête de gicleur./Coloque el quemador del horno sobre la caperuza del orificio del quemador del horno.

Reverse steps 6 through 9 to reassemble oven.

Pour assembler à nouveau le four, suivez les étapes 6 à 9 en inversant leur ordre.

Invierta los pasos 6 al 9 para reensamblar el horno.

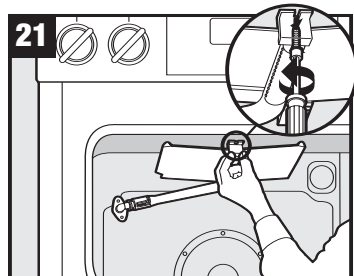

21
Remove screw and slide the broil burner forward until the pin clears rear wall./Enlevez la vis et faites glisser en avant le brûleur de gril jusqu'à ce que le tenon se trouve dégagé de la paroi arrière./Retire el tornillo y deslice el quemador de asar hacia adelante hasta que el pasador quede libre de la pared trasera.

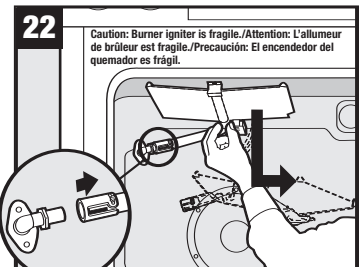

22
Slip the broil burner off the broil orifice hood./Sortez le brûleur de gril de la tête du gicleur de gril./Deslice el quemador de asar para sacarlo de la caperuza del orificio.

Gas Conversion Instructions, JGS8850BD*, JGS8860BD*

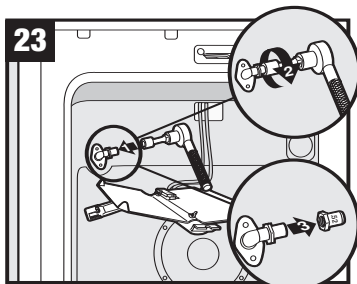

Remove #52 natural broil orifice hood./Retirez la tête du gicleur de grill n° 52 pour gaz naturel./Retire la caperuza del orificio de gas natural #52 del quemador de asar.

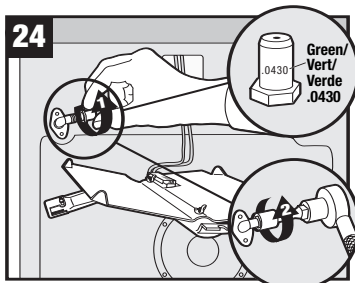

Install green .0430 LP broil orifice hood. **DO NOT OVERTIGHTEN.**/Installez la tête du gicleur de grill verte .0430 pour GPL. **NE SERREZ PAS TROP.**/Instale la caperuza verde de 0,0430 para gas LP del orificio del quemador de asar. **NO APRIETE DEMASIADO.**

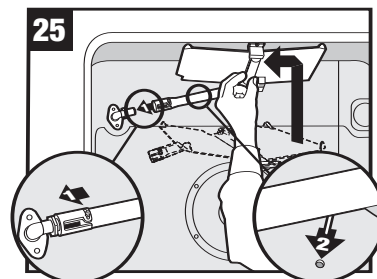

Place the broil burner on the broil orifice hood. **CAUTION:** Carefully insert burner pin in oven back./Mettez le brûleur de grill sur la tête du gicleur de grill. **ATTENTION:** Insérez soigneusement le tenon du brûleur dans le four./Coloque el quemador de asar en la caperuza del orificio.**PRECAUCIÓN:** Inserte cuidadosamente el pasador en la parte trasera del horno.

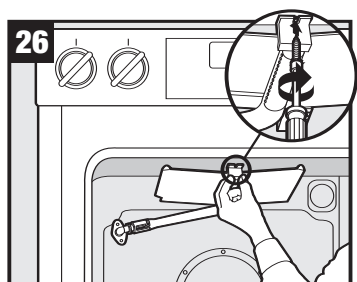

Reposition the broiler burner and tighten screw. Re-assemble oven./Remettez en place le brûleur de grill et serrez la vis. Remontez le four./Vuelva a colocar el quemador de asar en su lugar y apriete el tornillo. Vuelva a ensamblar el horno.

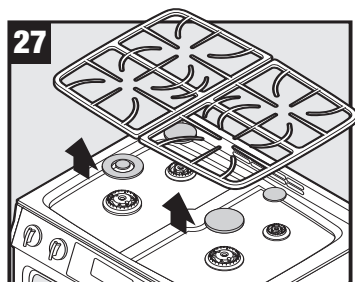

Remove the top grates. Remove the burner caps./Retirez les grilles supérieures. Retirez les chapeaux de brûleur./Retire las rejillas superiores. Retire las tapas de los quemadores.

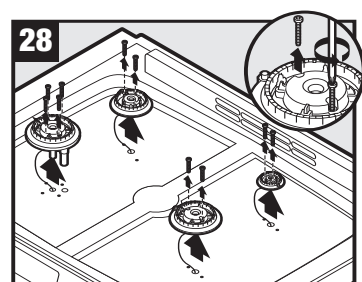

Remove screws and burner head./Retirez les vis et la tête de brûleur./Retire los tornillos y la cabeza del quemador.

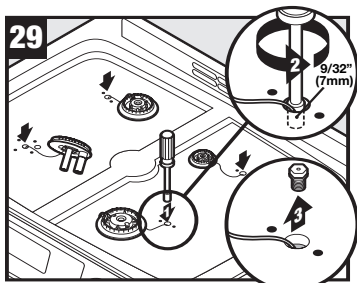

Carefully remove gas orifice hoods and convert one burner at a time./Enlevez soigneusement les têtes de gicleur pour gaz naturel et convertissez un brûleur à la fois./Retire cuidadosamente las caperuzas de los orificios de gas y convierta un quemador a la vez.

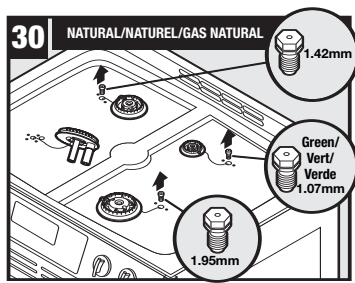

IMPORTANT: Remove and keep old natural gas orifice hoods./**IMPORTANT:** Retirez et conservez les anciennes têtes de gicleur pour gaz naturel./**IMPORTANTE:** Retire y conserve las tapas usadas de los orificios de gas natural.

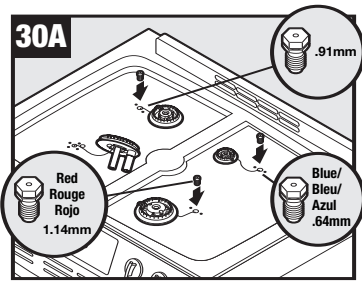

Replace with LP gas orifice hoods. **DO NOT OVERTIGHTEN.**/Remplacez-les avec des têtes de gicleur pour GPL. **NE SERREZ PAS TROP.**/Reemplácelas con caperuzas de orificios de gas LP. **NO APRIETE DEMASIADO.**

Gas Conversion Instructions, JGS8850BD*, JGS8860BD*

31 NATURAL/NATUREL/GAS NATURAL

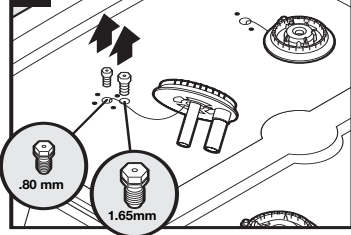

IMPORTANT: Remove and keep old natural gas orifice hoods./**IMPORTANT:** Retirez et conservez les anciennes têtes de gicleur pour gaz naturel./**IMPORTANTE:** Retire y conserve las tapas usadas de los orificios de gas natural.

31A

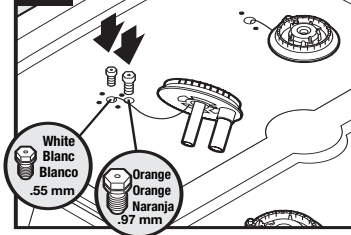

Replace with LP gas orifice hoods. **DO NOT OVERTIGHTEN.**/Remplacez-les avec des têtes de gicleur pour GPL. **NE SERREZ PAS TROP.**/Reemplácelas con caperuzas de orificios de gas LP. **NO APRIETE DEMASIADO.**

32

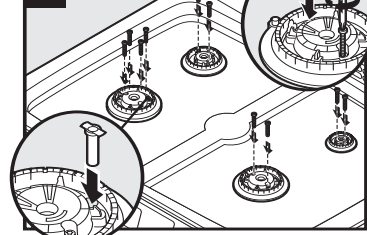

Replace burner heads and screws. (Hand tighten.) Drop in LP choke./Réinstallez les têtes de brûleur et les vis. (Serrez-les à la main.) Posez l'étrangleur pour GPL./Vuelva a instalar las cabezas y los tornillos del quemador. (Apriete a mano). Coloque el obturador de gas LP en su lugar.

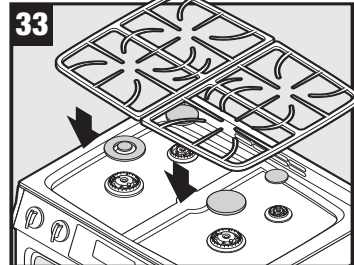

Replace burner caps. Replace grates./Remettez les chapeaux de brûleur. Remettez les grilles./Vuelva a instalar las tapas de los quemadores. Vuelva a instalar las rejillas.

34

Turn on gas and electrical supply to product.

Ouvrez le gaz et l'électricité alimentant l'appareil.

Abra el suministro de gas y conecte el suministro eléctrico al producto.

NOTE: When reversing an LP conversion back to natural gas, the LP choke in step 32 **MUST** be removed.

REMARQUE : Lorsque vous faites une reconversion du GPL au gaz naturel, l'étrangleur pour GPL de l'étape 32 **DOIT** être retiré.

NOTA: Cuando revierta una conversión de gas LP para usar gas natural, **DEBE** retirar el obturador de gas LP en el paso 32.

Low Flow Adjustment/Réglage bas débit/Ajuste del flujo mínimo

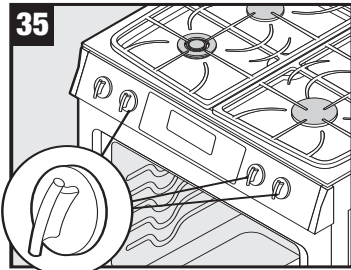

NOTE: Repeat steps 37-39 for single burners./**REMARQUE:** Répétez les étapes 37 à 39 pour les brûleurs simples./**NOTA:** Repita los pasos 37 a 39 para los quemadores sencillos.

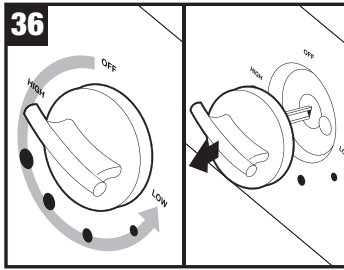

Adjust each single surface burner one at a time. Light burner and turn to lowest setting. Remove knob./Ajustez chaque brûleur de surface simple un par un. Allumez le brûleur et réglez-le au niveau le plus bas. Retirez le bouton./Ajuste los quemadores superiores sencillos uno a la vez. Encienda el quemador y ajústelo al nivel másbajo. Retire la perilla.

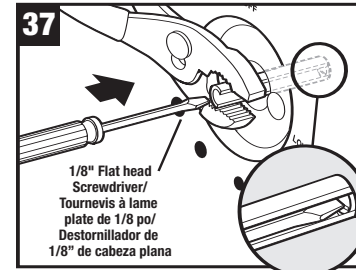

Hold knob stem in LOW position. Insert screwdriver to engage screw./Tenez la tige du bouton en position LOW. Introduisez le tournevis pour tourner la vis./Mantenga la varilla de la perilla en el ajuste 'LOW' (Bajo). Inserte el destornillador en el tornillo.

Gas Conversion Instructions, JGS8850BD*, JGS8860BD*

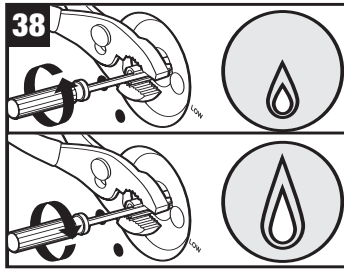

Adjust flame height with screwdriver./Ajustez la hauteur de la flamme avec le tournevis./Ajuste la altura de la llama con el destornillador.

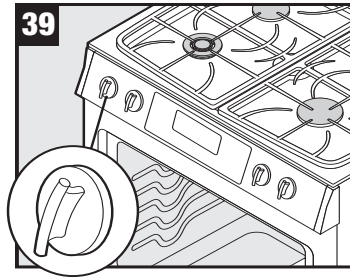

NOTE: Double burner only./REMARQUE: Brûleur double uniquement./NOTA: Quemador doble solamente.

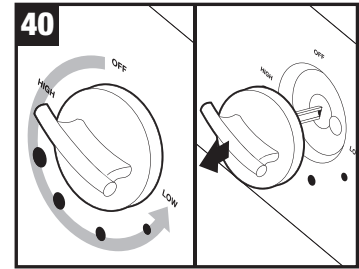

Adjust double surface burner. Light burner and turn to lowest setting where both inner and outer ring are lit. Remove knob./Ajuster le brûleur de surface double. Allumez le brûleur et réglez-le au niveau le plus bas où les deux cercles (intérieur et extérieur) sont allumés. Retirez le bouton./Ajuste el quemador superior doble. Encienda el quemador y ajústelo al nivel más bajo en el que se enciendan los anillos interior y exterior. Retire la perilla.

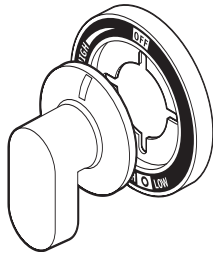

NOTE: For this style of knob, the bezel MUST be removed to make the flame adjustments to the Double Burner./REMARQUE: Pour ce style de bouton, la plaque DOIT être retirée pour effectuer les réglages des flammes du brûleur double./NOTA: Para este tipo de perilla, DEBE retirar el marco de la perilla para realizar los ajustes de las llamas del quemador doble.

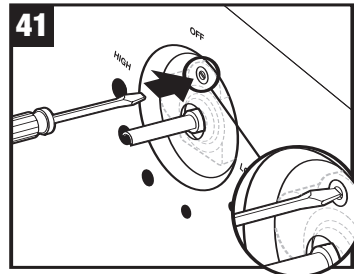

Insert screwdriver to engage screw./Introduisez le tournevis pour tourner la vis./Inserte el destornillador en el tornillo.

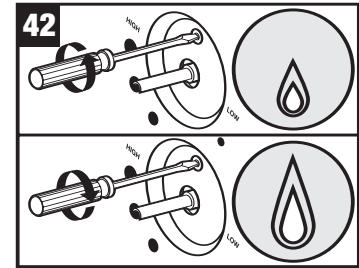

Adjust flame height with screwdriver./Ajustez la hauteur de la flamme avec le tournevis./Ajuste la altura de la llama con el destornillador.



Verify proper flame height and appearance./Vérifiez la taille appropriée des flammes et leur apparence./Verifique la altura y apariencia correctas de la llama.

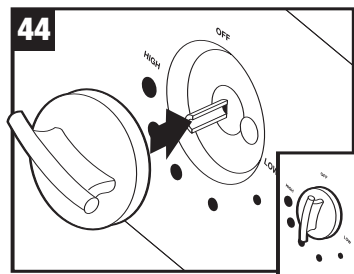

Replace knob. Turn OFF burners./Remettez les boutons. Mettez les brûleur sur OFF (ARRÊT)/Vuelva a instalar las perilla. APAGUE los quemadores.

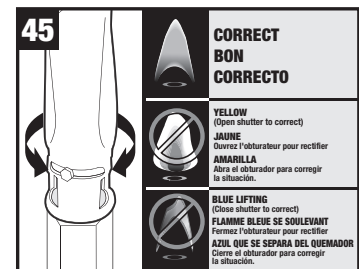

If necessary, adjust both oven burner shutters for correct flames. Secure shutter opening with screw./Au besoin, ajustez les deux obturateurs du brûleur du four pour obtenir les flammes appropriées. Fixez l'obturateur avec la vis./De ser necesario, ajuste ambos obturadores del quemador del horno para obtener la llama correcta. Fije la abertura del obturador con el tornillo.

Gas Conversion Instructions, JGS8850BD*, JGS8860BD*

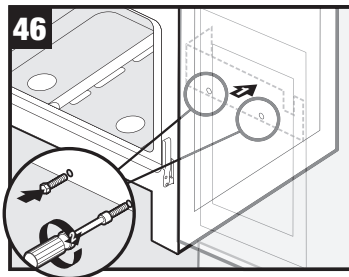

46
Replace panel and screws./Remettez le panneau et les vis./Vuelva a instalar el panel y los tornillos.

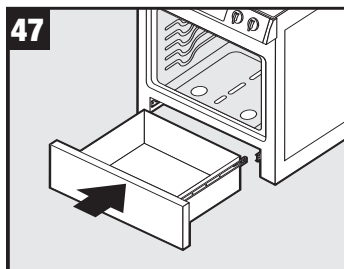

47
Replace warming drawer./Remplacez le tiroir de réchauffage./Vuelva a instalar el cajón de calentamiento.

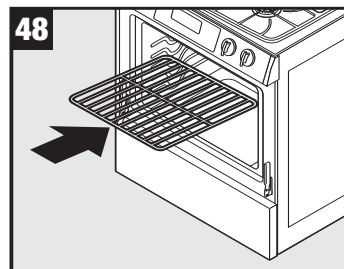

48
Replace oven rack./Remettez la grille de four./Vuelva a instalar la rejilla del horno.

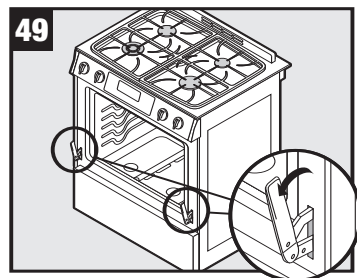

49
Move hinges into the first stop position./Placez les charnières à la première position d'arrêt./Mueva las bisagras al primer tope.

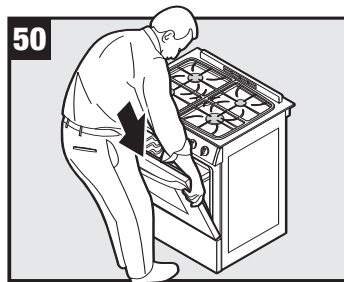

50
Replace oven door./Remplacez la porte du four./Vuelva a instalar la puerta del horno.

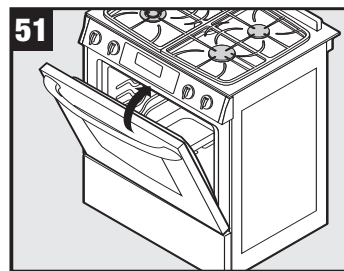

51
Close oven door. Complete./Fermez la porte du four. Terminé./Cierre la puerta del horno. Completo.

Gas Conversion Instructions, JGS9900BD*

Rev 2-1/06 Gas Downdraft/Part No. 8101P725-60

LP Propane Conversion Instructions



Instructions de conversion au GPL/ Instrucciones de conversión a gas LP propano

• Only qualified personnel should convert this range./Seul un personnel qualifié doit procéder à la conversion de cette cuisinière./La estufa sólo debe ser convertida por personal calificado. • Retain natural orifices for future conversion./Conservez les gicleurs pour gaz naturel pour une conversion ultérieure./Guarde los orificios de gas natural para una conversión futura. • Reverse this procedure for LP to natural conversion./Procédez inversement pour la conversion du GPL au gaz naturel./Invierta este procedimiento para convertir el producto de gas LP a gas natural.

This range is equipped with fixed orifices on all burners and a convertible appliance regulator. The unit serial plate states which gas it was adjusted for at the factory. To convert the unit to either Natural gas or LP gas will require replacement of the oven orifice hoods, and the top burner orifice shutters, and adjustment of the oven burner shutters and the appliance pressure regulator converter cap.

Cette cuisinière est équipée de gicleurs fixes sur tous les brûleurs et d'un détendeur convertible. La plaque signalétique de cet appareil indique le réglage fait à l'usine pour un certain gaz. La conversion de l'appareil au gaz naturel ou au GPL nécessite le remplacement des têtes de gicleur du four et des têtes de gicleur du brûleur supérieur, ainsi que le réglage des obturateurs de brûleur du four et du capuchon du convertisseur du détendeur.

Esta estufa viene equipada con orificios fijos en todos los quemadores y con un regulador convertible para electrodomésticos. La placa de serie de la unidad indica para qué tipo de gas se calibró en la fábrica. Para convertir la unidad a gas natural o a gas LP es necesario reemplazar las caperuzas de los orificios del horno y los orificios de los quemadores superiores, además de ajustar los obturadores del quemador del horno y la tapa del convertidor del regulador de presión del electrodoméstico.

Inlet pressure to the appliance pressure regulator should be as follows for both operation and checking of appliance pressure regulator setting:/La pression d'arrivée au détendeur de l'appareil doit être la suivante pour le fonctionnement et la vérification du réglage du détendeur ./La presión de entrada al regulador de presión debe ser la siguiente tanto para el funcionamiento normal como para verificar el ajuste del regulador de presión:

Inlet Pressure in inches of water column Pression d'arrivée en pouces à la colonne d'eau Presión de entrada en pulgadas c.d.a.	Natural Gas Gaz naturel Gas natural	LP Gas GPL Gas LP
Max/Max./Máx. Min/Min./Min.	14 (36 cm) 6 (16 cm)	14 (36 cm) 11 (28 cm)

1

Turn off gas and electrical supply to product.

Fermez le gaz et coupez l'électricité alimentant l'appareil.

Cierre el suministro de gas y desconecte el suministro eléctrico al producto.

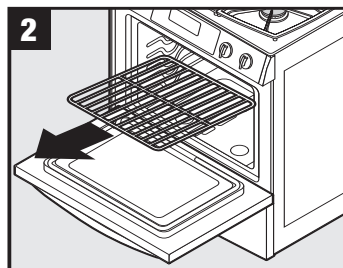

Remove oven rack./Retirez la grille du four./Retire la parrilla del horno.

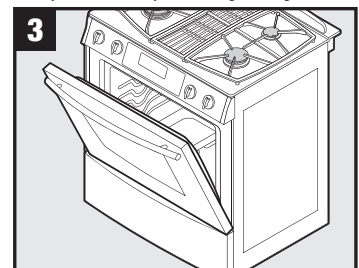

Open oven door to the first stop position./Ouvrez la porte du four jusqu'à la première position d'arrêt./Abra la puerta del horno hasta el primer tope.



Remove oven door by holding both sides and pulling up./Retirez la porte du four en la tenant par les deux côtés et en la tirant vers le haut./Retire la puerta del horno sosteniendo ambos lados y tirando de ella hacia arriba.

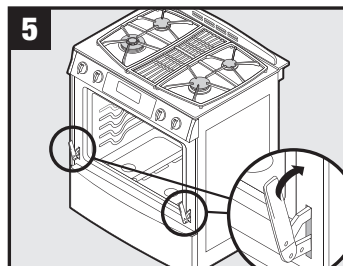

Move hinges to the closed position./Placez les charnières à la position de fermeture./Mueva las bisagras a la posición cerrada.

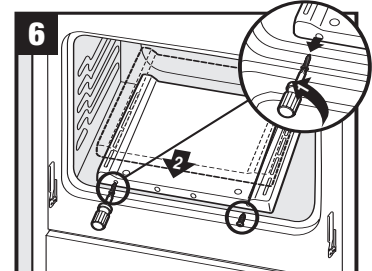

Remove oven bottom./Retirez la sole du four./Retire el fondo del horno.

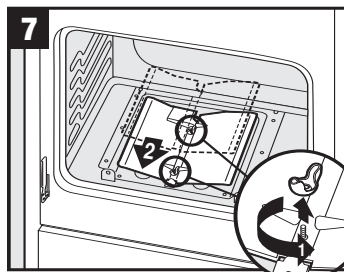

Remove oven baffle./Enlevez le déflecteur de four./Retire el deflector del horno.

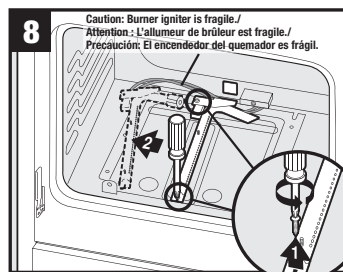

Remove oven burner./Retirez le brûleur du four./Retire el quemador del horno.

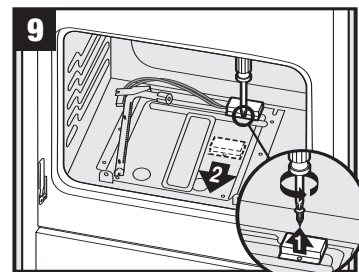

Remove cover./Retirez le couvercle./Retire la cubierta.

Gas Conversion Instructions, JGS9900BD*

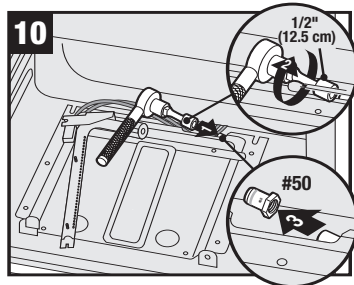

Remove brass orifice hood./Retirez la tête de gicleur en laiton./Retire la tapa de bronce del orificio

You MUST start bake and broil hoods by hand to avoid cross threading.

Vous DEVEZ insérer les têtes de gicleur de cuisson et de grill à la main afin d'éviter qu'un filetage ne soit faussé.

Usted DEBE iniciar el enroscado de las tapas de horneado y asado a mano para evitar dañar las roscas.

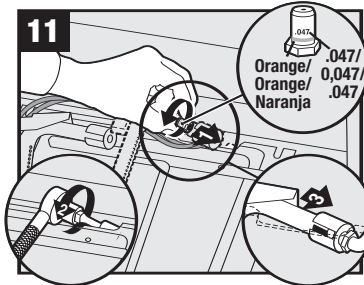

Replace orifice hood. **DO NOT OVER TIGHTEN./** Remettez la tête de gicleur **SANS TROP LA SERRER./** Reemplace la tapa del orificio. **NO APRIETE DEMASIADO.**

Reverse steps 6 through 9 to reassemble oven.

Pour assembler à nouveau le four, suivez les étapes 6 à 9 en inversant leur ordre.

Invierta los pasos 6 al 9 para reensamblar el horno.

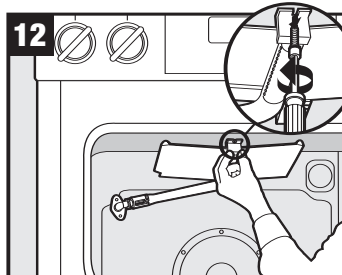

Remove screw and slide the broil burner forward until the pin clears rear wall./Enlevez la vis et faites glisser en avant le brûleur de grill jusqu'à ce que le tenon se trouve dégagé de la paroi arrière./Retire el tornillo y deslice el quemador de asar hacia adelante hasta que el pasador quede libre de la pared trasera.

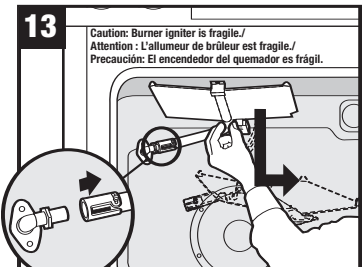

Slip the broil burner off the broil orifice hood./Sortez le brûleur de grill de la tête du gicleur de grill./Deslice el quemador de asar para sacarlo de la caperuzza del orificio.

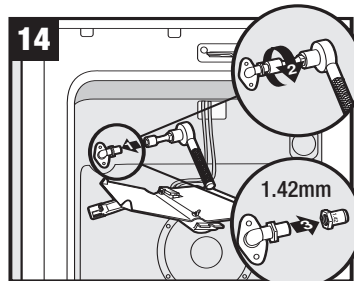

Remove 1.42 natural broil orifice hood./Retirez la tête du gicleur de grill n° 1,42 pour gaz naturel./Retire la caperuzza del orificio de gas natural 1.42 del quemador de asar..

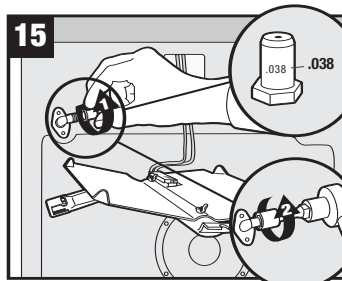

Install .038 LP broil orifice hood. (4-5 turns-DO NOT OVERTIGHTEN)/Installez la tête du gicleur de grill, .038 pour GPL. (4 à 5 tours – NE SERREZ PAS TROP)/Instale la caperuzza de 0,038 para gas LP del orificio del quemador de asar. (4 a 5 vueltas – NO APRIETE DEMASIADO)

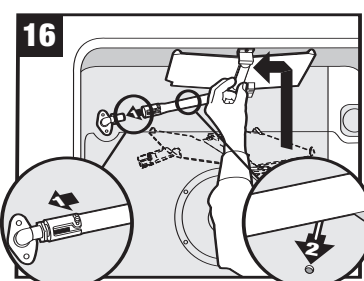

Place the broil burner on the broil orifice hood. **CAUTION: Carefully insert burner pin in oven back./** Mettez le brûleur de grill sur la tête du gicleur de grill. **ATTENTION : Insérez soigneusement le tenon du brûleur dans le four./Coloque el quemador de asar en la caperuzza del orificio.PRECAUCIÓN: Inserte cuidadosamente el pasador en la parte trasera del horno.**

***CAUTION: Pin MUST be inserted into back of hole on oven to secure burners (C5)./*ATTENTION : Le tenon DOIT être introduit à l'arrière du trou du four pour bien loger les brûleurs (C5)./*ATENCIÓN: El pasador DEBE ser introducido en la parte trasera del agujero en el horno para asegurar los quemadores (C5).**

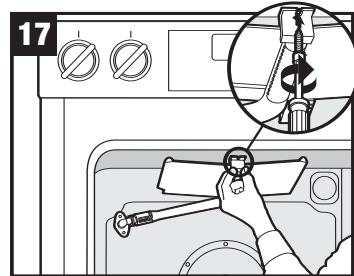

Reposition the broiler burner and tighten screw. Re-assemble oven. (See steps 2-4)/Remettez en place le brûleur de grill et serrez la vis. Remontez le four. (Voyez les étapes 2-4)/Vuelva a colocar el quemador de asar en su lugar y apriete el tornillo. Vuelva a ensamblar el horno. (Vea los pasos 2 al 4.)

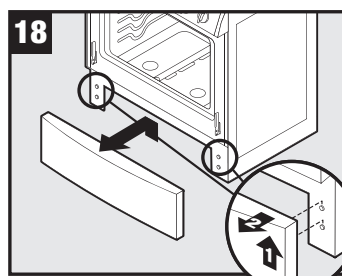

Remove access panel./Retirez le panneau d'accès./Retire el panel de acceso.

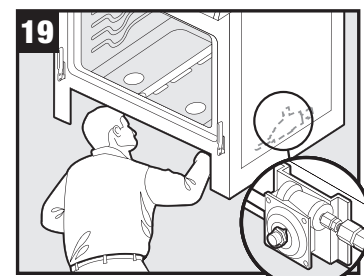

Locate regulator from the front./Repérez le détendeur à l'avant./Ubique el regulador desde la parte delantera.

Gas Conversion Instructions, JGS9900BD*

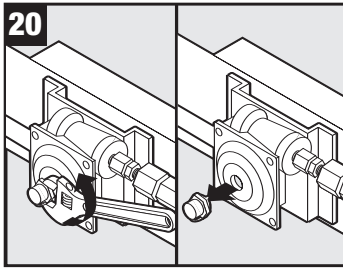

20
Unscrew the regulator cap./Dévissez le capuchon du détendeur./Desenrosque la tapa del regulador.

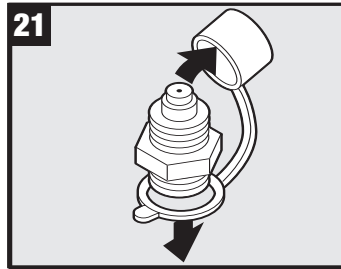

21
Remove the plastic cap./Retirez le capuchon en plastique./Retire la tapa de plástico.

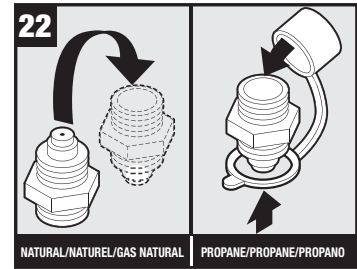

22
Flip the regulator cap and replace the plastic cap./Abattez le capuchon du détendeur et installez le capuchon en plastique./Invierta la tapa del regulador y vuelva a colocar la tapa de plástico.

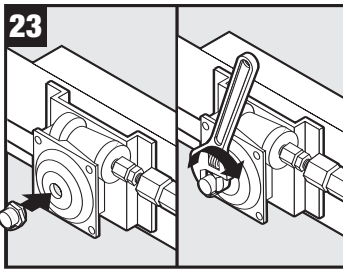

23
Screw the cap securely back into place. DO NOT OVER TIGHTEN./ Revissez bien le chapeau. NE LE SERREZ PAS TROP FORT./ Enrosque la tapa firmemente en su lugar. NO APRIETE DEMASIADO.

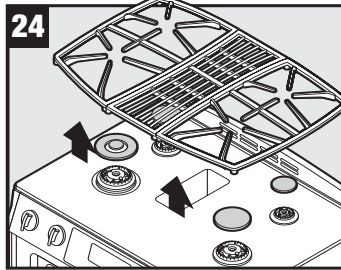

24
Remove the top grates. Remove the burner caps./Retirez les grilles supérieures. Retirez les chapeaux de brûleur./Retire las rejillas superiores. Retire las tapas de los quemadores.

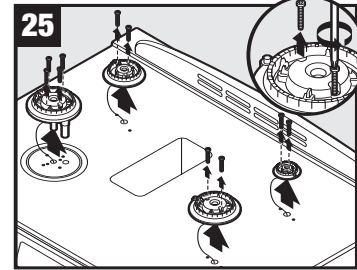

25
Remove screws and burner head./Retirez les vis et la tête de brûleur./Retire los tornillos y la cabeza del quemador.

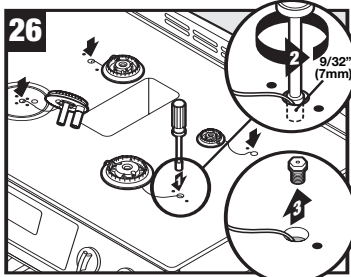

26
Carefully remove gas orifice hoods and convert one burner at a time./Enlevez soigneusement les têtes de gicleur pour gaz naturel et convertissez un brûleur à la fois./Retire cuidadosamente las caperuzas de los orificios de gas y convierta un quemador a la vez.

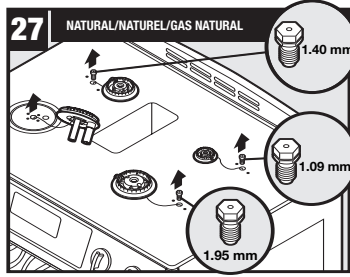

27
IMPORTANT: Remove and keep old natural gas orifice hoods./IMPORTANT : Retirez et conservez les anciennes têtes de gicleur pour gaz naturel./ IMPORTANT: Retire y conserve las tapas usadas de los orificios de gas natural.

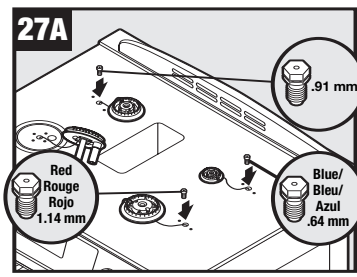

27A
Replace with LP gas orifice hoods. DO NOT OVERTIGHTEN./ Remplacez-les avec des têtes de gicleur pour GPL. NE SERREZ PAS TROP./Reemplácelas con caperuzas de orificios de gas LP. NO APRIETE DEMASIADO.

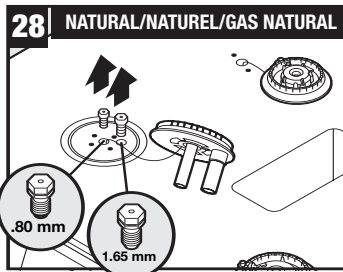

28
IMPORTANT: Remove and keep old natural gas orifice hoods./IMPORTANT : Retirez et conservez les anciennes têtes de gicleur pour gaz naturel./ IMPORTANT: Retire y conserve las tapas usadas de los orificios de gas natural.

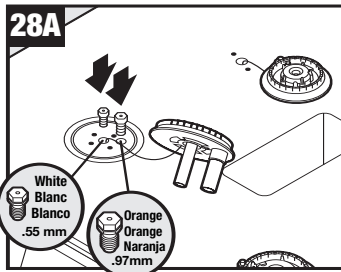

28A
Replace with LP gas orifice hoods. DO NOT OVERTIGHTEN./ Remplacez-les avec des têtes de gicleur pour GPL. NE SERREZ PAS TROP./Reemplácelas con caperuzas de orificios de gas LP. NO APRIETE DEMASIADO.

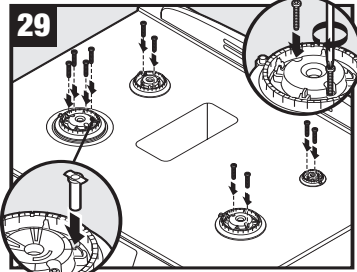

29
Replace burner heads and screws. (Hand tighten.) Drop in LP choke./Réinstallez les têtes de brûleur et les vis. (Serrez-les à la main.) Posez l'étrangleur pour GPL./Vuelva a instalar las cabezas y los tornillos del quemador. (Apriete a mano.) Coloque el obturador de gas LP en su lugar.

Gas Conversion Instructions, JGS9900BD*

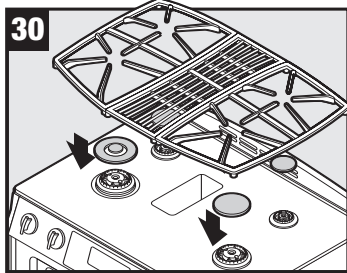

Replace burner caps. Replace grates./Remettez les chapeaux de brûleur. Remettez les grilles./Vuelva a instalar las tapas de los quemadores. Vuelva a instalar las rejillas.

31 Turn on gas and electrical supply to product.
Ouvrez le gaz et l'électricité alimentant l'appareil.
Abra el suministro de gas y conecte el suministro eléctrico al producto.

NOTE: When reversing an LP conversion back to natural gas, the LP choke in step 29 MUST be removed.

REMARQUE : Lorsque vous faites une reconversion du GPL au gaz naturel, l'étrangleur pour GPL de l'étape 29 DOIT être retiré.

NOTA: Cuando reverta una conversión de gas LP para usar gas natural, DEBE retirar el obturador de gas LP en el paso 29.

Low Flow Adjustment/Réglage bas débit/Ajuste del flujo mínimo

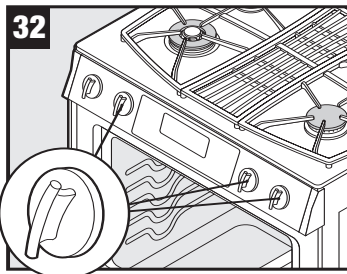

NOTE: Repeat steps 33-35 for single burners./REMARQUE : Répétez les étapes 33 à 35 pour les brûleurs simples./NOTA: Repita los pasos 33 a 35 para los quemadores sencillos.

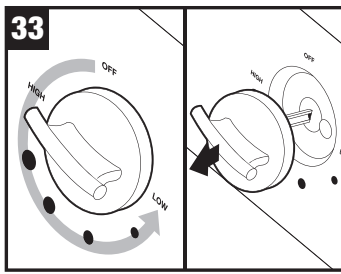

Adjust each single surface burner one at a time. Light burner and turn to lowest setting. Remove knob./Ajustez chaque brûleur de surface simple un par un. Allumez le brûleur et réglez-le au niveau le plus bas. Retirez le bouton./Ajuste los quemadores superiores sencillos uno a la vez. Encienda el quemador y ajústelo al nivel más bajo. Retire la perilla.

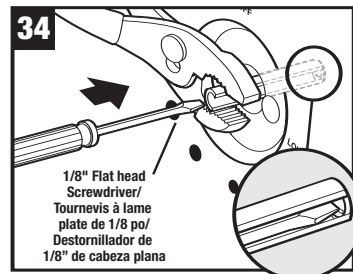

Hold knob stem in LOW position. Insert screwdriver to engage screw./Tenez la tige du bouton en position LOW. Introduisez le tournevis pour tourner la vis./Mantenga la varilla de la perilla en el ajuste 'LOW' (Bajo). Inserte el destornillador en el tornillo.

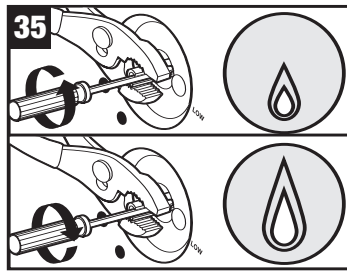

Adjust flame height with screwdriver./Ajustez la hauteur de la flamme avec le tournevis./Ajuste la altura de la llama con el destornillador.

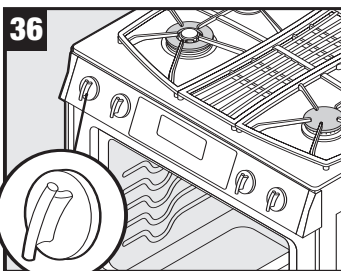

NOTE: Double burner only./REMARQUE : Brûleur double uniquement./NOTA: Quemador doble solamente.

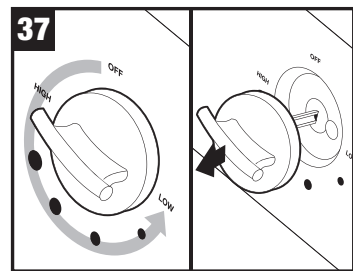

Adjust double surface burner. Light burner and turn to lowest setting where both inner and outer ring are lit. Remove knob./Ajustez le brûleur de surface double. Allumez le brûleur et réglez-le au niveau le plus bas où les deux cercles (intérieur et extérieur) sont allumés. Retirez le bouton./Ajuste el quemador superior doble. Encienda el quemador y ajústelo al nivel más bajo en el que se encienden los anillos interior y exterior. Retire la perilla.

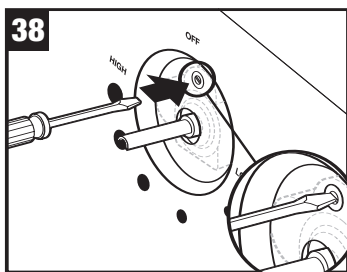

Insert screwdriver to engage screw./Introduisez le tournevis pour tourner la vis./Inserte el destornillador en el tornillo.

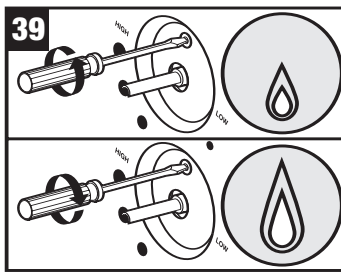

Adjust flame height with screwdriver./Ajustez la hauteur de la flamme avec le tournevis./Ajuste la altura de la llama con el destornillador.

40

	CORRECT BON CORRECTO
	YELLOW JAUNE AMARILLA
	BLUE LIFTING FLAMME BLEUE SE SOULEVANT AZUL QUE SE SEPARA DEL QUEMADOR

Verify proper flame height and appearance./Vérifiez la taille des flammes et leur apparence./Verifique la altura y apariencia correctas de la llama.

Gas Conversion Instructions, JGS9900BD*

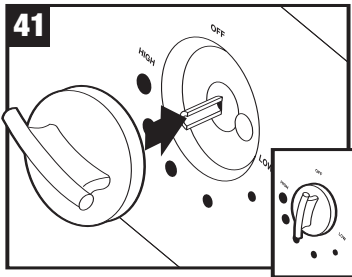

41 Replace knobs. Turn OFF burners./Remettez les boutons. Mettez les brûleurs sur OFF (ARRÊT)./Vuelva a instalar las perillas. APAGUE los quemadores.

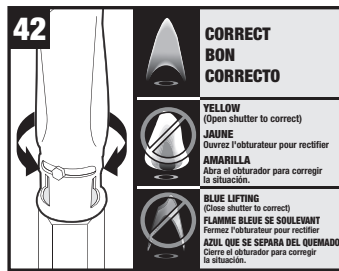

If necessary, adjust both oven burner shutters for correct flames. Secure shutter opening with screw./Au besoin, ajustez les deux obturateurs du brûleur du four pour obtenir les flammes appropriées. Fixez l'obturateur avec la vis./De ser necesario, ajuste ambos obturadores del quemador del horno para obtener la llama correcta. Fije la abertura del obturador con el tornillo.

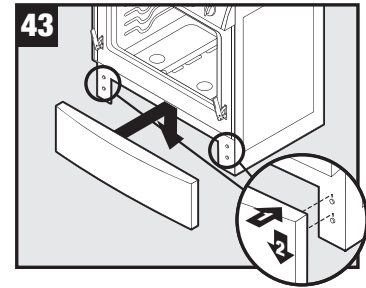

43 Replace access panel./Remettez le tiroir de rangement./Vuelva a instalar el cajón de almacenamiento.

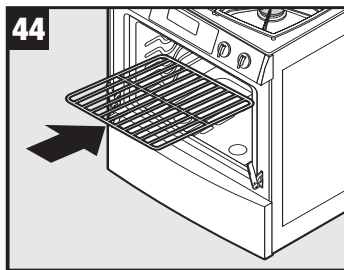

44 Replace oven rack./Remette la grille de four./Vuelva a instalar la rejilla del horno.

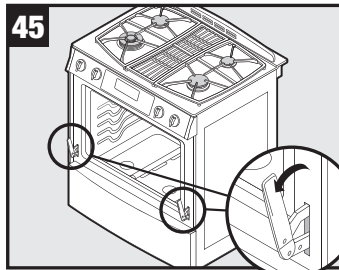

45 Move hinges into the first stop position./Placez les charnières à la première position d'arrêt./Mueva las bisagras al primer tope.

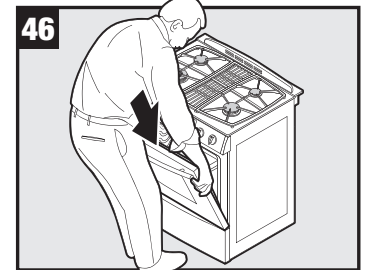

46 Replace oven door./Replacez la porte du four./Vuelva a instalar la puerta del horno.

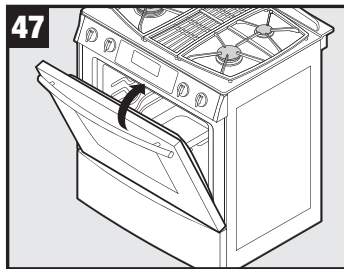

47 Close oven door./Fermez la porte du four./Cierre la puerta del horno.

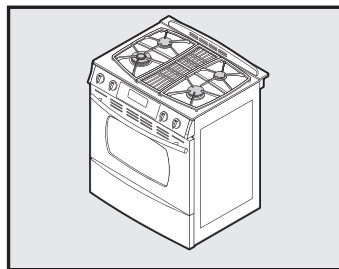

48 Complete./Terminé./Completo.