

MAYTAG

Maytag Appliances

Electric Slide-In Service Manual

16010191
Issued 9/00

General Safety Precautions

Information contained in **this manual is intended for use by a qualified service technician.** The technician is required to be familiar with proper and safe procedures to be followed when repairing electric, gas, and microwave appliances. All tests and repairs are to be performed using proper tools and measuring devices designed for appliance diagnosis and repair. All component replacements should be made **using only factory approved replacement parts.**

Electrical shock and injury can result if service or repairs are attempted by an unqualified individual. **Improper disassembly, assembly or adjustments can create hazardous conditions.**

Even for a skilled technician, a risk of injury or electrical shock exists while performing service or repairs. **Electrical injury can be serious or fatal. Extreme caution must taken when performing voltage checks on individual components of an appliance.**

NOTE: Except as necessary to perform a particular step in servicing a product, the electrical power supply should always be disconnected when servicing a product.

To avoid possible injury, the appliance must be properly grounded. Never plug in or direct wire an appliance unless it is **properly grounded in accordance with all local and national codes.** See the installation instructions that originally accompanied the product for proper grounding procedures.

P/N 16010191

**MAYTAG
Electric Slide-In
Service Manual**

MODELS:

**CDE852
CDE8520
SCE30500
SCE30600
SCE70600
SEG196
SEG196*C
SVD8310S
SVD48600
SVD48600*C
SVD48600P
SVD48600PC
SVE47100
SVE47500
SVE47600
SVE47600*C
SVE87600**

**The following new service manual will replace original service manual P/N
16009097 and EGR001-00. Please discard the original service manuals
and refer to new service manual.**



Contents

Introduction	i
General Safety Precautions	ii
Model / Serial Plate	iii
Wiring Information	iii
Model Number Identification	iv
Serial Number Identification	iv
Slide-In Range Features	v
Cooking Fundamentals	vii
Anti-Tip Device	vii
Accessories	viii
Wiring Installation	x
Gas Components	xi
Gas Leaks	xi
Section 1. General Troubleshooting	1-1
General Procedures	1-1
Grounding and Polarity	1-2
Troubleshooting - Test Functions	1-3
Fault Codes	1-6
Troubleshooting	1-7
Multiplexing Circuitry-SVE47600	1-10
Power Relay Board Connections - SVE47600	1-11
Display Board Connections - SVE47600	1-12
Down Draft Board Connections - SVE47600	1-12
Circuit Board Connections - SVE47600	1-13
Circuit Board Connections - SVE47100	1-14
Temperature Bands Chart - SVE47100	1-15
Membrane Connections - SVE47600 & SVE47500	1-16
ESC Keyboard Diagram - SVE87600	1-17
Electronic Surface Control - SVE87600	1-18
Circuit Board Connections - SVE87600	1-19
Test Equipment	1-20
Electrical Test Equipment	1-20
Ventilation Test	1-21
Ducting	1-22
Ventilation System	1-23
Blower & Convect Assembly Parts List	1-23
Blower & Convect Assembly Illustration	1-24
Section 2. General Component Access	2-1
Getting Started	2-1
Cartridges	2-1
Accessories	2-1
Accessories & Cartridge Conversions	2-2

Door Assembly	2-3
Oven Door	2-3
Oven Door Handle	2-3
Oven Door Hinge Replacement	2-4
Oven Door Gasket.....	2-4
Oven Hinge Pockets.....	2-4
Oven Door (SVD8310S)	2-5
Oven Components	2-5
Bake Element Removal	2-5
Broil Element Removal	2-5
Oven Light	2-5
Oven Light (SVD8310S)	2-6
Oven Vent/Smoke Eliminator	2-6
Oven Cavity	2-6
Convection Motor Assembly	2-6
Front Closure Replacement	2-6
Regulator (SVD only)	2-6
Gas Supply	2-7
Required Outlet Pressures	2-7
Service Drawer (Select Models)	2-7
Access Panel	2-7
Oven Racks	2-7
Grease Containers	2-8
Blower-Motor	2-8
Meat Probe (Selected Models)	2-8
Oven Sensor	2-9
Back Panel Access	2-9
Cooling Fan Access	2-10
Relay Board (Downdraft)	2-10
Power Relay Board (Bake/Broil Convect)	2-10
Spark Module (Select Models)	2-10
Relay Switch	2-10
Terminal Block	2-10
Control Panel Access	2-10
Selector/Thermostat (Select Models)	2-11
Burner Indicator Lights	2-11
Infinite Switch (Select Models)	2-11
Electronic Clock	2-11
Electronic Surface Control	2-11
Main Top Components	2-12
Main Top Removal	2-12
Door Lock Assembly	2-12
Door Lock Mechanism (SVD8310S)	2-13
Internal Controls (SVD8310S)	2-13
Surface Burner Module	2-14
High Limit Switch	2-14
Spark Ignitor/Wires	2-14
Burner Tubes/Orifices	2-15
Supply Tube	2-15
Manifold/Valves/Stem Switches	2-15

Pan Switch	2-16
Cycle Switch	2-16
Ceramic Radiant Elements.....	2-16
Ventilation System.....	2-16

Section 3. General Component Testing 3-1

Electrical Components 3-1

Infinite Switch	3-1
------------------------------	------------

Dual Element Infinite Switch	3-2
---	------------

Electronic Surface Control	3-3
---	------------

Fault Codes	3-5
-------------------	-----

Bake Element	3-6
--------------------	-----

Broil Element	3-6
---------------------	-----

Control Voltages	3-6
------------------------	-----

Element, Ceran Top (Large)	3-6
----------------------------------	-----

Element, Ceran Top (Small)	3-6
----------------------------------	-----

Element, Ceran Top (Large-Dual)	3-6
---------------------------------------	-----

Surface Unit Switches (Some Models).....	3-7
--	-----

Sensor and Lock Circuits (SVD8310S)	3-7
---	-----

Cooling Motor (SVD8310S)	3-7
--------------------------------	-----

Relay (SVD8310S)	3-7
------------------------	-----

Solenoid (SVD8310S)	3-7
---------------------------	-----

Relay D. L. B. (SVD48600PC)	3-7
-----------------------------------	-----

Mode of Oven Operation (SVD8310S)	3-8
--	------------

Mode of Oven Operation (Basic)	3-9
---	------------

Gas Components	3-10
-----------------------------	-------------

Air Shutter Adjustment.....	3-10
-----------------------------	------

Adjust Oven Temperature (SVD8310S)	3-11
--	------

Relay	3-11
--------------------	-------------

Spark Module	3-11
---------------------------	-------------

Cause & Effect	3-12
---------------------------------	-------------

Section 4. Wiring & Specific Model Information..... 4-1

CDE852, CDE8520 Diagram.....	4-1
-------------------------------------	------------

CDE852, CDE8520 Schematic	4-2
--	------------

SCE30500 Diagram	4-3
-------------------------------	------------

SCE30500 Schematic.....	4-4
--------------------------------	------------

SCE30600 Diagram	4-5
-------------------------------	------------

SCE30600 Schematic.....	4-6
--------------------------------	------------

SCE70600 Diagram	4-7
-------------------------------	------------

SCE70600 Schematic.....	4-8
--------------------------------	------------

SEG196 Diagram	4-9
-----------------------------	------------

SEG196 Schematic.....	4-10
------------------------------	-------------

SEG196*C Diagram.....	4-11
------------------------------	-------------

SEG196*C Schematic	4-12
---------------------------------	-------------

SVD8310S Diagram	4-13
-------------------------------	-------------

SVD8310S Schematic	4-14
---------------------------------	-------------

SVD48600 Diagram	4-15
-------------------------------	-------------

SVD48600 Schematic	4-16
SVD48600*C Diagram	4-17
SVD48600*C Schematic	4-18
SVD48600P Diagram	4-19
SVD48600P Schematic	4-20
SVD48600PC Diagram	4-21
SVD48600PC Schematic	4-22
SVE47100 Diagram (Series 01)	4-23
SVE47100 Diagram (Series 14)	4-24
SVE47100 Schematic (Series 14)	4-25
SVE47500 Diagram	4-26
SVE47500 Schematic	4-27
SVE47600 Diagram	4-28
SVE47600 Schematic	4-29
SVE47600*C Diagram	4-30
SVE47600*C Schematic	4-31
SVE87600 Diagram	4-32
SVE87600 Schematic	4-33

Introduction

This manual is printed in a loose format and is divided into sections relating to a general group of components an/or service procedures. Each section is further subdivided to describe a particular component or service procedure.

The subdividing of the subject matter, plus the loose leaf form, will facilitate the updating of the manual as new or revised components are added or new models are introduced.

Each page of the manual will be identified in the lower, right or left hand corner, and as new or revised pages are published, the manual can easily be updated by following the filing instructions on the cover letter of the supplement.

This service manual is a valuable tool and care should be taken to keep it up-to-date by prompt and proper filing of subsequent pages as they are used.

Listed below are the Jenn-Air / Maytag Models covered in this manual:

**CDE852
CDE8520
SCE30500
SCE30600
SCE70600
SEG196
SEG196*C
SVD8310S
SVD48600
SVD48600*C
SVD48600P
SVD48600PC
SVE47100
SVE47500
SVE47600
SVE47600*C
SVE87600**

General Safety Precautions

General Safety Precautions

Information contained in **this manual is intended for use by a qualified service technician**. The technician is required to be familiar with proper and safe procedures to be followed when repairing electric, gas, and microwave appliances. All tests and repairs are to be performed using proper tools and measuring devices designed for appliance diagnosis and repair. All component replacements should be made **using only factory approved replacement parts**.

Electrical shock and injury can result if service or repairs are attempted by an unqualified individual. **Improper disassembly, assembly or adjustments can create hazardous conditions**.

Even for a skilled technician, a risk of injury or electrical shock exists while performing service or repairs. **Electrical injury can be serious or fatal**. Extreme caution must be taken when performing voltage checks on individual **components of an appliance**.

NOTE: Except as necessary to perform a particular step in servicing a product, the electrical power supply should always be disconnected when servicing a product.

To avoid possible injury, the appliance must be properly grounded. Never plug in or direct wire an appliance unless it is **properly grounded in accordance with all local and national codes**. See the installation instructions that originally

In our continuing effort to improve the quality and performance of our cooking products, it may be necessary to make changes to the appliance without revising this manual.

For Microwave Oven operation (select models), refer to the use of the service manual provided for the microwave oven.

The model and serial number can be found on the data plate located on the oven front frame. The model number identifies features, sizes and engineering changes. The model number assist the technician in establishing the proper service procedures for the different variations of cooking products.

Model / Serial Plate

The Model / Serial plate is located at the bottom left side behind the access panel/service drawer on the front frame. The model number is very important to the technician for ordering parts both in and out of warranty. Always be sure to use the complete model number when ordering parts.

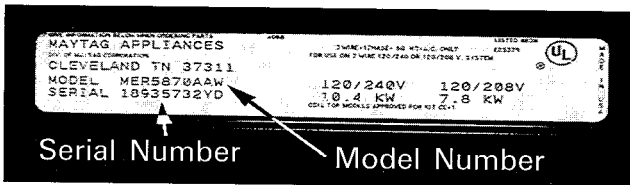

Serial plate enlarged and rotated to show detail. This information is important when calling tech support or ordering parts.

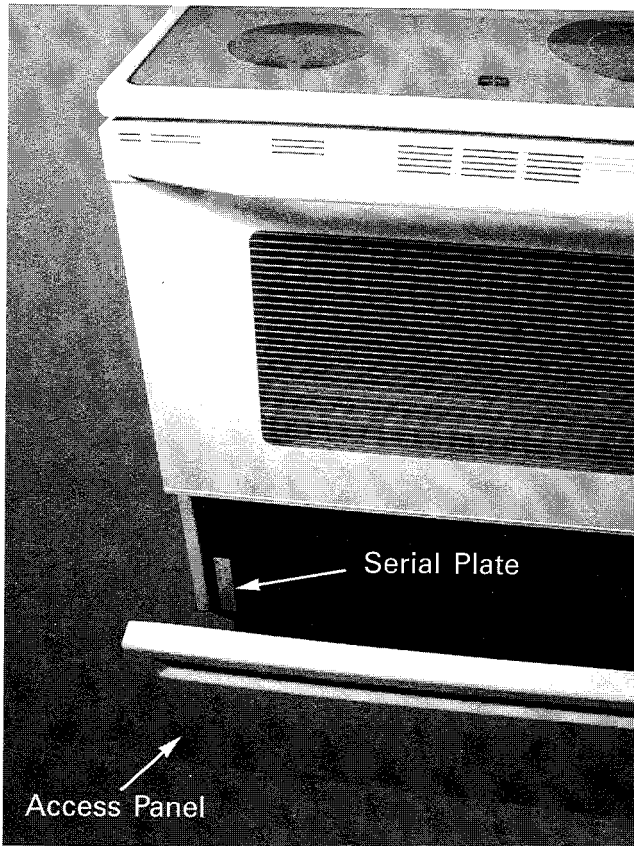

Serial Plate Location

⚠ IMPORTANT
Unique product information for specific models is found in the wiring and model specific information section of this manual.

Wiring Information

A wiring diagram / schematic is supplied with the unit. It is attached to the back side of access panel on slide-in models or the rear right inside side panel of freestanding models and may be accessed by removing the access panel / service drawer. Please return the diagram to the storage compartment for future use.

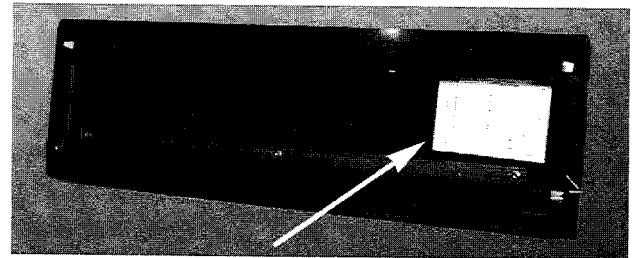
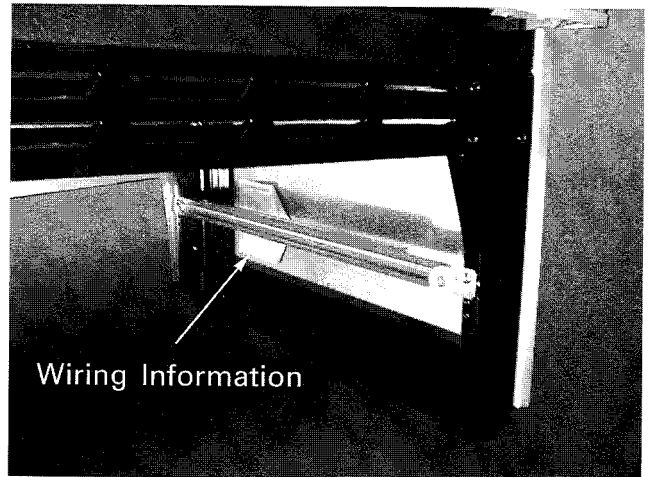

⚠ IMPORTANT
Wiring information in this manual was accurate at the time of manual production. Wiring information is subject to change at any time. Please refer to wiring information on the actual product for most current information.

Items packed with the product:

Many service calls are the result of the customer's lack of understanding as to the correct operation of the product. Several items are packed with the product to help avoid this situation. It sometimes becomes the servicer's obligation to explain the correct use and care of the appliance.

Model Number Identification

COOKING-RANGES

S	C	E	3	0	6	0	0	B
A	B	C	D	E	F	G	H	I

A PRODUCT GROUP

- F = Free-Standing
- S = Slide-In
- D = Drop-In

B VENTILATION TYPE

- C = Conventional
- V = Ventilated (Downdraft)

C PRODUCT FUEL

- D = Dual Fuel
- E = Electric
- G = Gas
- P = Propane Gas

D COOKTOP

- 1 = Coil/Atmospheric Burner
- 2 = Disk/Sealed Burner
- 3 = Glass Ceramic Radiant Halogen Induction
- 4 = Modular
- 5 = Coil/Atmospheric Burner w/ Electronics
- 6 = Disk/Sealed Burner w/ Electronics
- 7 = Glass Ceramic w/ Electronics
- 8 = Modular w/ Electronics

E COOKTOP

- 0 = All Four Coil/Disk Radiant Elements
- 1 = Open (No Grill)
- 3 = Radiant/Halogen
- 6 = Induction
- 7 = Grill + Open
- 8 = Grill + Open

F OVEN TYPE

- 0 = Standard Clean
- 1 = Self-Clean
- 2 = Convection
- 3 = Ultra Speed
- 5 = Self-Clean w/ Electronics
- 6 = Convection w/ Electronics
- 7 = Ultra Speed w/ Electronics

G FEATURES

- 0 = No Backguard Light
- 1 = Backguard Light

H ENGINEERING CHANGES

I COLOR

- B = Black
- W = Designer White
- A = Designer Almond
- S = Stainless
- P = Pro-Style TM
- R = Almond
- T = White

Serial Number Identification

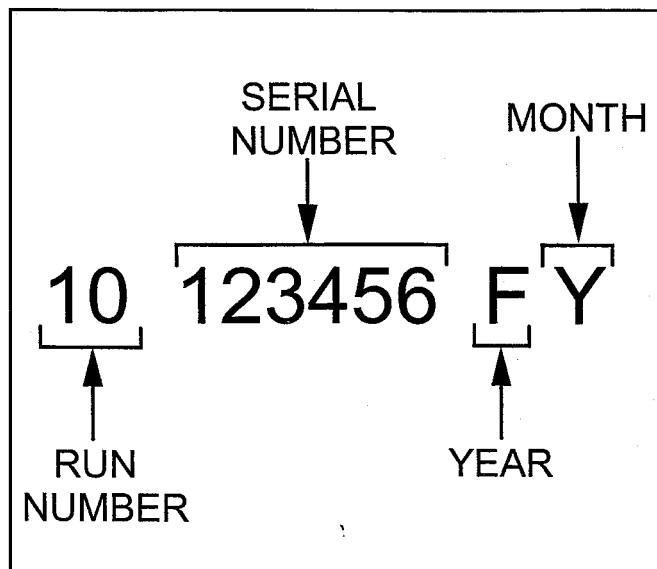

The serial number is indirectly related to servicing the appliance, however is necessary when ordering replacement parts. November 1, 1992, Jenn-Air/Maytag began using a 10 digit serial number format. Prior to this an 8 digit serial number format was used. The first two digits denote the run number.

The next six (6) numbers represent the unit serial number. The seventh and eighth digit represents the year and month the unit was built. This number is also necessary for product information feedback to the manufacturer for quality improvements/adjustments.

Slide-In Range Features

Basic Features

- **Bake/Broil oven**
 - * Conventional baking and roasting
 - * Broil
- **Oven window and light**
 - * Large panaview™ oven window
 - * Oven light automatically comes on whenever the oven door is opened. When oven door is closed, push the oven light switch to turn oven light on or off.
- **Electronic Clock**
 - * Time of day
 - * Timer
 - * Clock Controlled baking or roasting
- **Infinite control settings**
 - * On settings other than "HI", you may adjust the control above or below the numbered setting. This applies to setting when using cooktop cartridges or when using the grill or any of the grill accessories.
 - * Suggested settings are provided as general guidelines.
- **Oven Cavity**
 - * High-grade porcelain finish
 - * Most oven capacities are the same size - 3.8 Cu. Ft.
 - * Model SVD8310S, Pro-Style™ oven capacity is 3.3 Cu. Ft.
- **Variable Temperature control broiling**
 - * The variable temperature broil feature means that a lower temperature can be selected. Use variable broil for delicate and long-term items.
 - * After touching the broil pad and "HI" appears in the display, touch the appropriate number pads for the desired temperature (temperature can be entered in 5° increments).
- **Excalibur™ Nonstick Grill Grate Finish - Grill models only**
 - * The grill grates are made from cast aluminum and are coated with the Excalibur™ nonstick finish.
- **Self-Cleaning oven**
 - * Has automatic (motorized) self-clean clock. When the oven controls are set to "CLEAN", the oven heats to temperatures that are higher than those used for cooking. The high temperatures cause food soil to burn off and substantially disappear. While this occurs, a device in the oven vent helps to consume normal amounts of smoke. The oven is vented through an opening under the air grille.

Additional Features

- **Dual Fuel™**
 - * Dual Fuel™ features a modular gas cooking surface combined with an electric bake and broil oven.

- ***Two-speed downdraft ventilation***
 - * The built-in ventilation system removes cooking vapors, odors and smoke.
 - * Two speed fan positions are: "HI", "LO" and OFF. The fan will come on at the "HI" speed with the "FAN PAD" is pressed to turn on. To set on "LO" speed, touch the fan "LO" or touch the fan pad twice to turn off from "HI" position.
- NOTE: There is a five second delay before the fan will switch from "HI" speed to "LO" speed**
- ***One-speed downdraft ventilation***
 - * Manually push the fan switch located on the control panel.
 - * The ventilation system will operate automatically when the grill element is in use. To cool an item, set it on the air grille and turn on the fan. The air being pulled over the item will quickly cool it.
- ***Dual mode convection***
 - * Convection bake and convection roast available on select models.
- ***Ultra Quick-start radiant elements***
 - * When an element is turned on, the element will heat up and the red glow of the heating element can be seen through the glass-ceramic top. It is normal to see the red glow of the element whenever it cycles on. The elements will cycle on and off for all control settings except HI. However, it may also cycle on HI if improper cookware is used.
- ***Ultra quick-twin dual radiant element***
 - * The left rear element is the dual radiant element. Push the control knob in and turn right for the large element or left for the small element.
- ***Energy-saver grill element***
 - * This element permits utilizing only half of the grill area or using different settings for the front and rear position of the element. When using this element, both cooktop controls, front and rear, must be turned on in order to use the full grill area.

Optional Features

- Deluxe Lighted backsplash
- Custom backsplash
- Side panels

Cooking Fundamentals

Even baking results are affected by:

- Oven Bakeware/pan finish
- Rack positions in oven
- Pan Placement on the oven rack

Speed of surface cooking is affected by:

- Cookware

Anti-Tip Device

Installation Of Anti-Tip Device (UL Required)

Underwriters Laboratory requires that all electric ranges meet stringent anti-tip requirements. All free standing ranges, gas and electric, are being shipped from our factory with an anti-tip device. The device is included for our customer's safety. It is important that the device be properly attached during the installation of the unit in the customer's home. The installation procedure is simple and is detailed in the instructions that accompany each range.

To check the range for proper installation of the anti-tip bracket: Use a flashlight and look underneath the bottom of the range to see that one of the rear leveling legs is engaged in the bracket slot. When removing appliance for cleaning or servicing, be sure anti-tip device is engaged when range is replaced. The anti-tip device secures the rear leveling leg to the floor, when properly engaged.

If the anti-tip device has not been installed, inform the consumer to notify the installer for proper installation.

To order, Anti-Tip Installation Kit, use **part number 12200020.**

Kit contains:	Part #	Description	Qty.
	705344	Bracket	2
	7101P274-60	Screws	4
	16000509	Instruction Sheet	1

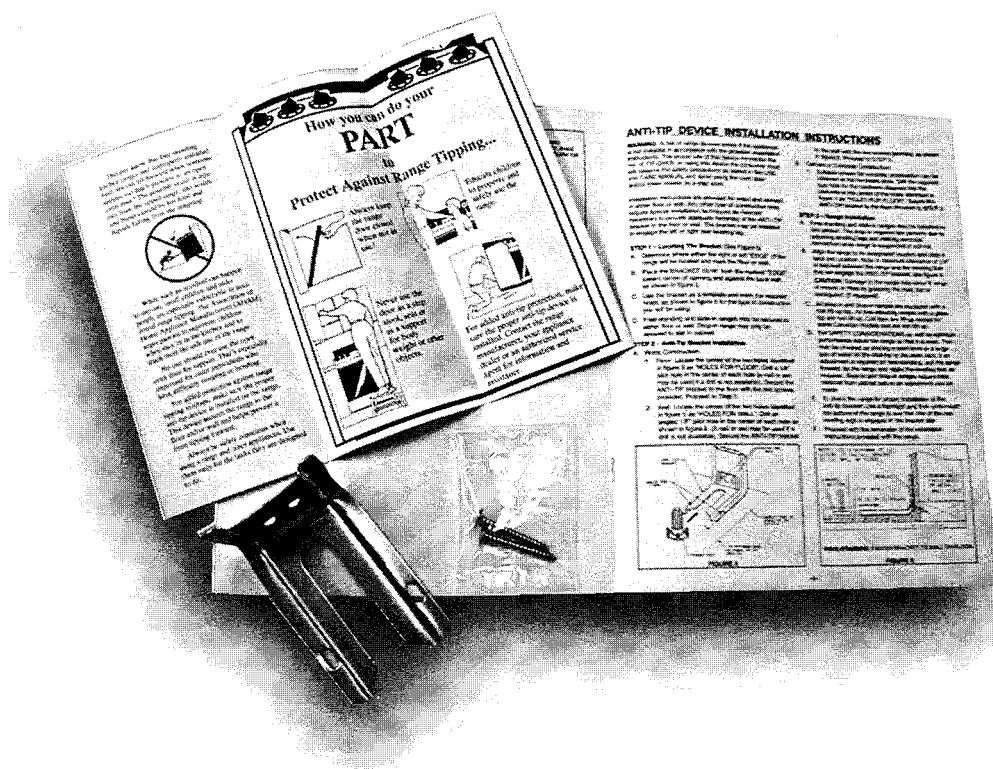

Accessories

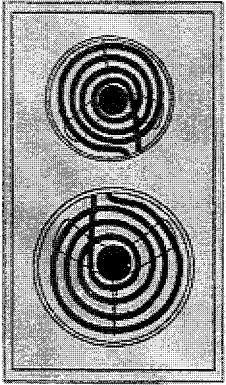

A100

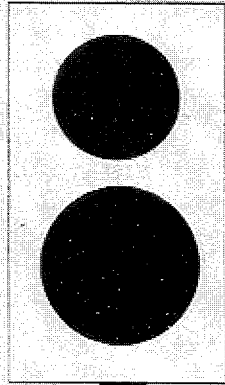

A106

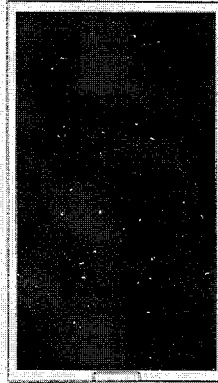

A122

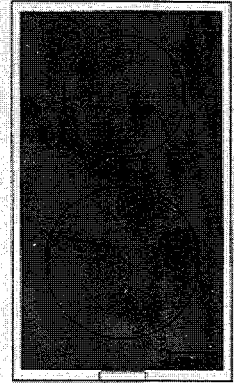

A126

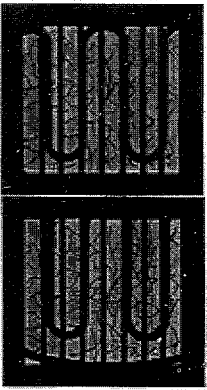

A158



A145A

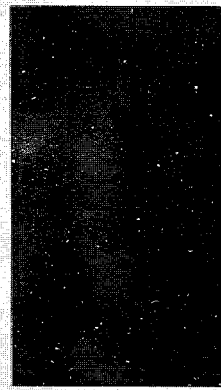

A302

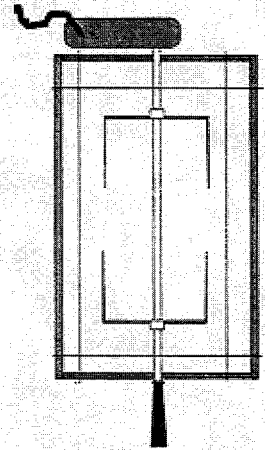

A312

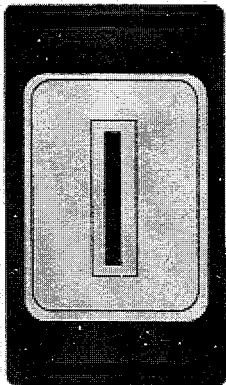

A335

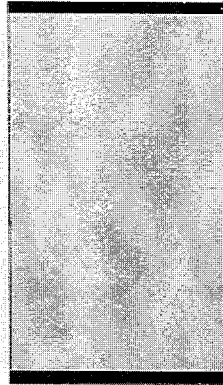

A341

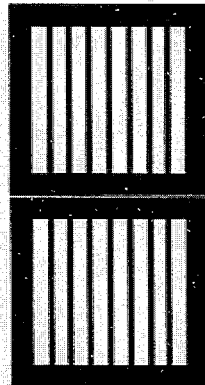

AE915

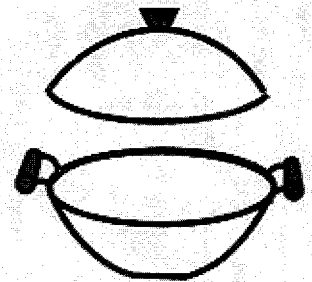

AO142

Accessories

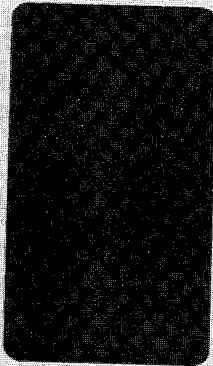

A350



A911



20000001

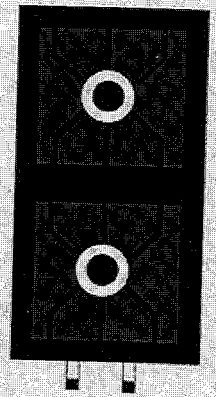

AG202

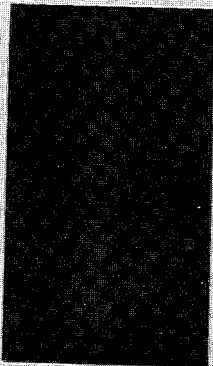

AG302

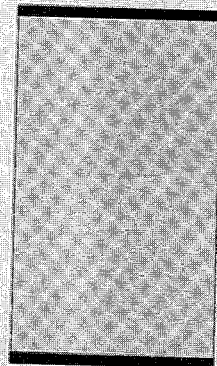

AG341

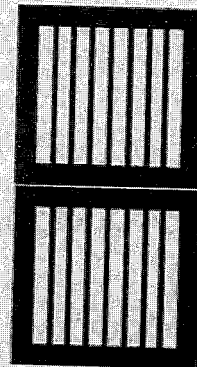

AG915

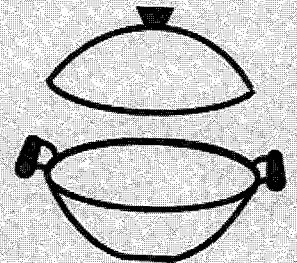

AO142

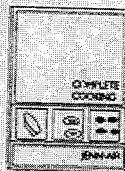

A905



A912

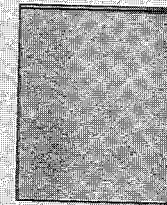

A913

Wiring Installation

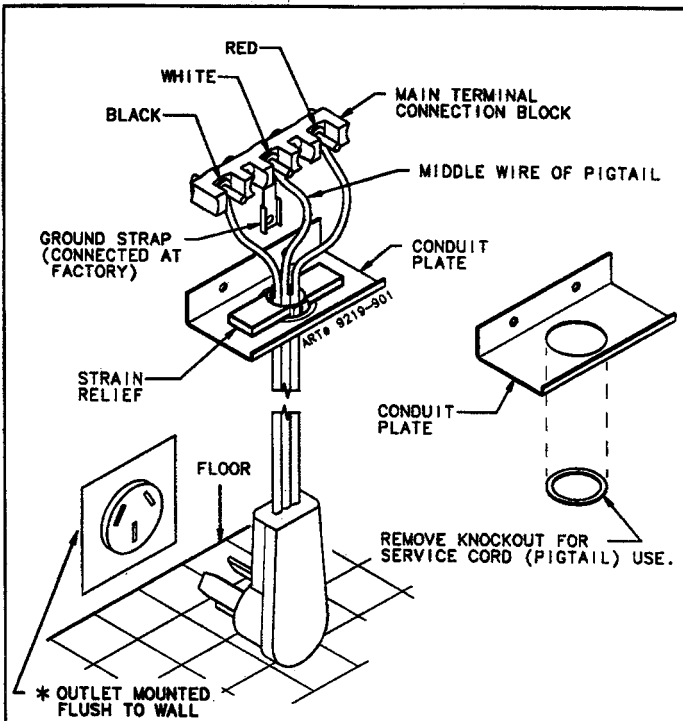

NORMAL - 3 WIRE PLUG

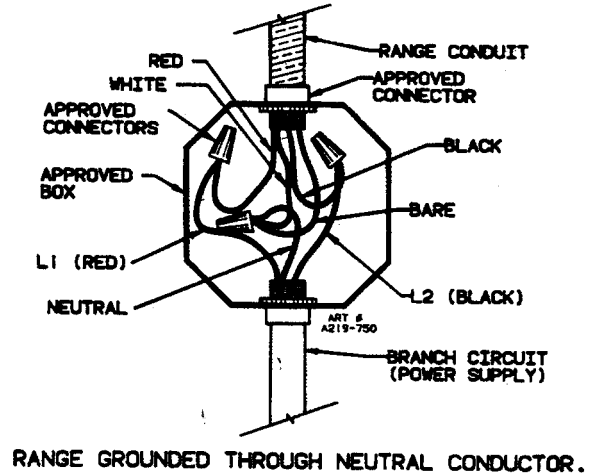

NORMAL - 3 WIRE CONDUIT

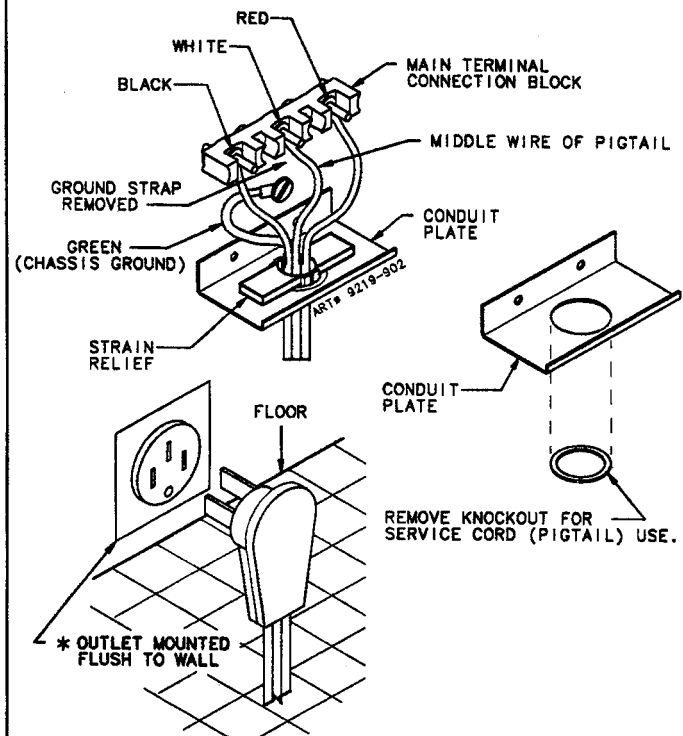

MOBILE HOME - 4 WIRE PLUG

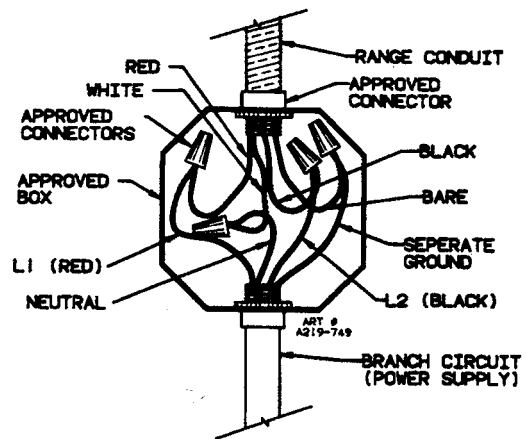

MOBILE HOME - 4 WIRE CONDUIT

Gas Components

NOTE: *Before replacing any component, check the following:*

- Be sure 120 VAC power is supplied to unit.
 - Be sure correct gas fuel, at correct pressure, is supplied to manifold inlet, that gas supply line is open and air has been bled from gas ways.
 - When an electrical component is non-operative, check to be sure the correct electrical leads are securely attached to it. Wire leads are color-coded and identified with stampings.
 - When an electrical malfunction cannot be readily located, use a continuity tester to trace circuit, including checking of wire harness itself for separated wires, splices, etc.
- If ducting and wall cap are not connected to blower vent, be sure deflected drafts are not causing ignition failure or other burner flame disturbance.
 - Good (or inoperative) parts, both electrical and mechanical, can often be easily identified by remote substitution; that is, for example, by disjoining wires from a component, or disjoining a stem switch from a valve, or a valve from a switch, and substitution the suspect part with a part known to be good outside the structure. This trial and error method is usually a time-saver.

Gas Leaks

CAUTION
NEVER CHECK FOR GAS LEAKS WITH AN OPEN FLAME.

Check for leaks using a soap and water solution.

Section 1. General Troubleshooting

General Procedures

This section is intended to assist you in diagnosing inoperative conditions which may develop in products manufactured by the Maytag corporation. Electrical testing is made with an appliance test meter and consists of checking for open or closed circuits. Mechanical checks are made through sight and sound, along with the use of a volt-wattmeter and clamp-on ammeter.



This information is intended for the technician who is familiar with the operation and construction of Maytag products.

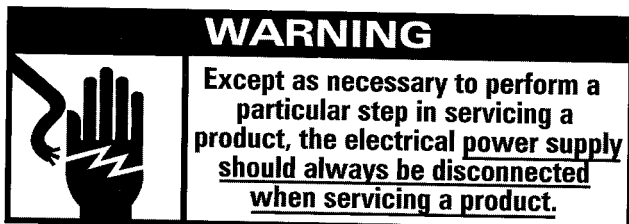

Electrical Component Testing

An easy procedure for testing electrical components is "continuity testing" with an appliance test meter.

Continuity is a complete or continuous path from one point in an electrical circuit to another. Continuity testing, as related to an electrical component, is the checking of a part for an "open" or "closed" circuit. A continuity check can be performed once the product being tested has been disconnected from its electrical supply and after appropriate wires have been removed from the terminals of the part being checked. Following manual activation of the part (if required) the probes of the test meter should be placed on the respective terminals. The readout from the test meter will indicate a completed (closed) circuit. Little or no value shown will indicate a broken or (open) circuit and a possible inoperative part.

Continuity testing is a process of eliminating those electrical components used in a given function of the product, until the inoperative part is found. By reviewing the list of possible electrical problems, under a given condition, and then performing appropriate continuity checks on the parts involved, you should be able to locate the electrical component which is inoperative.

Electrical components fall into two general categories:

1. **Loads** - Devices that **use** (consume) electricity. Examples would include fan motors, elements, lamps, solenoids, etc.
2. **Switches** - Devices that **control** the supply of electricity to the load or loads in a circuit. Examples include lid switches, timer contacts, selector switch and relay contacts. Continuity tests of "load" devices will show varying levels of resistance from very low for some transformer and motor windings to very high for some timer motors and components on electronic control boards. Usually it is more important to know if there is a path for current flow through a device (continuity) than to the exact resistance (ohms) of the device. Resistance values are included in this manual for your information.

Loads - Loads can be powered by using a motor test cord to confirm operation or failure. The motor test cord used in conjunction with a volt-watt meter will also show power required to operate the device. Continuity tests of switches will show virtually no resistance across closed contacts. Resistance even low values indicates burned or dirty contacts in a switch.

Grounding and Polarity

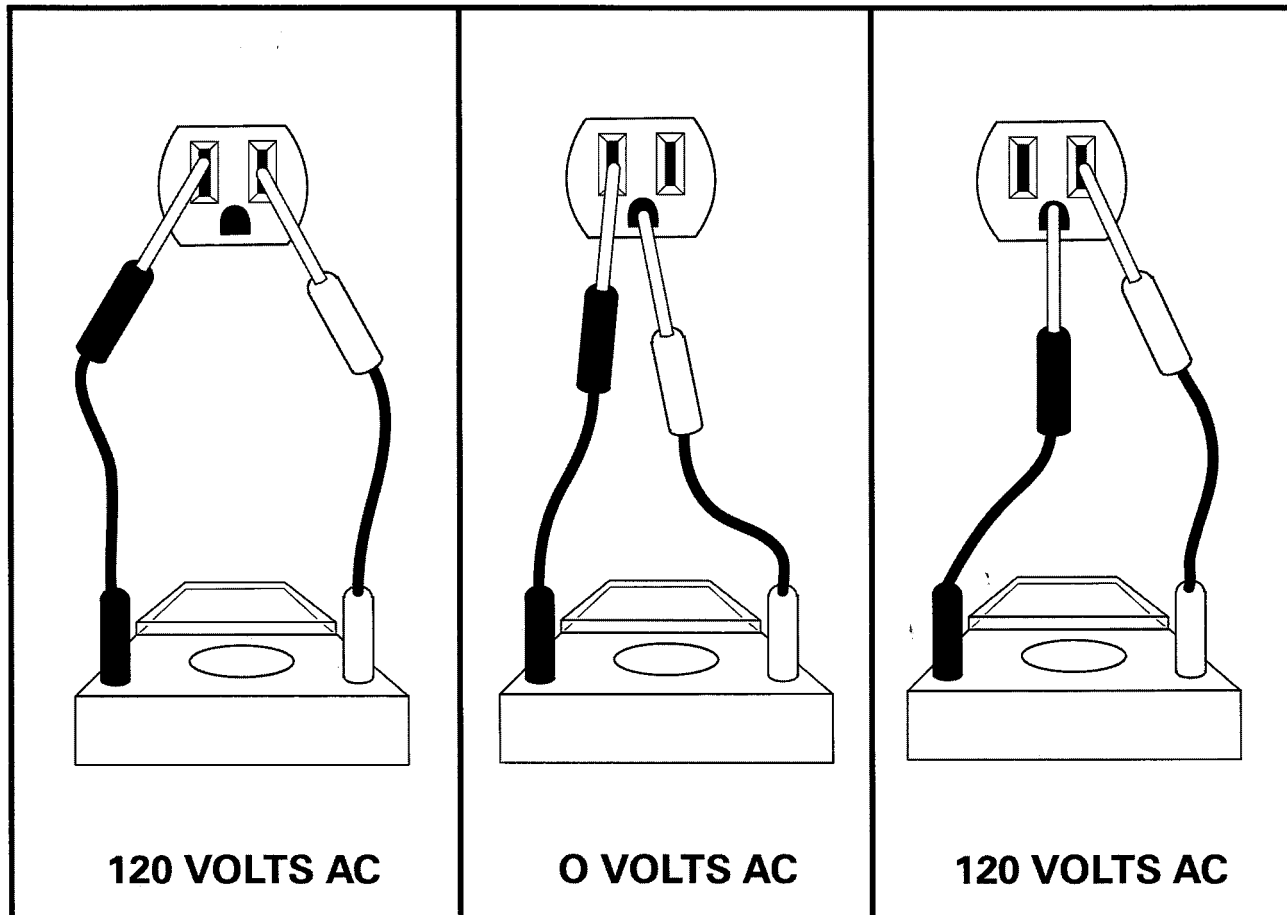

The above illustration shows a simple grounding and polarity check using a common appliance multimeter

⚠ IMPORTANT
Never alter or remove the grounding prong from the power cord. Use of grounding adapters is not recommended.

The receptacle used for all Maytag products operating on 120 VAC must be properly grounded and polarized.

The power cord used on the appliances is equipped with a three (3) prong polarized grounding plug for protection against shock hazard and should be plugged directly into a properly grounded and polarized receptacle.

It is the responsibility of the person installing the appliance to ensure it is adequately grounded and polarized at the point of

installation. All local conditions and requirements must be taken into consideration.

In cases where only a two prong receptacle is available, it is the personal responsibility of the customer to have it replaced with a properly grounded and polarized 3 prong receptacle. All grounding and wiring should be done in accordance with national and local codes. ***Use of adapters is not recommended by Maytag*** unless the receptacle has been grounded through the center plate cover screw.

Troubleshooting - Test Functions

Test Access	The test mode can be accessed by holding the stop time key down at power up or by holding the stop time key down for 10 seconds within 5 minutes of power up mode. No other key can be pressed before the stop time key, that would block the test mode access.
Test Exit	Exit the test mode by pushing the cancel key or test will self-terminate after 16 seconds from the last key command chosen.
Test Function	Test mode is performed by pushing a keypad and testing for an output response. When the keypad is released, the output is terminated and the display will return to the "-" display. The following is a list of key actions and responses.

NOTE:

1. Each time a key is pressed a tone will sound.
2. If there is a red dot on the IC-chip and the display board when you touch the oven light key, the oven light will come on and a beep will occur. The beep lets you know there is a good circuit, in case the light is blown. Also, when you press the fan speed key on a dual speed downdraft, it will beep each time you touch the key. The first beep will be the high setting, the second beep will be the low setting, and the third beep will be off.

Bake Key	Activates bake relay on the power relay board.
Broil Key	Activates broil relay on the power relay board.
Convect Bake Key	Activates convect bake relay (CVBAK) on the power relay board.
Convect Roast Key	Activates convect roast relay (CVRST) on the power relay board.
Fan Key	(Downdraft Range only) Activates the downdraft fan relay on the auxillary board. NOTE 1: First press of the fan key activates high speed, second press of the fan key activates low speed relay on the auxillary relay board, and the third press of the fan key turns the fan relay board off. NOTE 2: <u>Fan always starts on high. There is a built-in 3 to 5 second delay when the fan key is pressed twice. This feature ensures that the fan motor starts on the high speed windings, and attains full speed before reducing to the low speed winding.</u>
Oven Light Key	Activates oven light (OVLN) relay on the power relay board. (See NOTE 2 above.)
Probe Key	Activates the display on the control to display the probe temperature.
Timer Keys	Activates the display to show factory codes in the blue displayed digits and oven temperature in red.
Clean Key	Activates blue display digits which shows the state of the door lock switches and the status of the user selectable options. See charts on page 1-2. NOTE: First (left) blue displayed digit is for user selectable options code and the fourth (right) blue digit is for the door lock switch status code.

Stop Time Key	Will activate the beeper 100% as long as the key is pressed. Also, it will display the control I. D. # in the blue time digits and the power relay board I D. # in the red temperature digits.
Clock Key	Activates all display segments to light.
Cook Time Key	Activates any fault codes stored in the memory. The time digits display any fault codes for the membrane and control board. The temperature digits display any fault codes for the power relay board. NOTE: <u>If 'FO' is displayed, there has not been any fault codes sensed in that portion of the system.</u> Any stored fault code can be cleared to FO, after repairs have been made, by entering the fast test and pressing both the cook time and stop time keys for 5 seconds.
Digital Input Keys	Activates the display to show the same digit (0-9) that is pressed.
Temperature Offset Change	Program bake above 500°, repress bake pad and hold for 3-4 seconds, the pad must be re-pushed within 3 seconds. The digital keys can be used to set the offset between positive (+) and negative (-). Entered values are rounded to the next 5° increment. (Example: pushing key 3 will display a 5° increment).
Clock and Temperature Change	The clock can be set to be displayed in 24 hour form. Also, temperature can be displayed in degree "C". To access, hold either timer keys down on power up. The two left digits will display the format for the clock, the right digit will display "F" or "C." The display can be toggled by pushing the bake or upper bake key to toggle the clock. The temperature display can be toggled from F to C by pushing the broil key or upper broil key on a double oven control.

If the board should lock up while working with the fast test procedure; it can be unlocked by powering down the appliance, waiting about 20 seconds, and reapplying power. Unplugging the J1 connector from the con-

trol board has the same effect as powering the board for purposes of the fast test procedure. Care must be taken to connect the J1 connector squarely to avoid causing "FC" and "F" fault codes.

User Selectable Options Display Codes				
Display Code	Deg. C	24 Hour Clock	Continuous EOC	60 Hz Reference
F	X	X	X	X
E		X	X	X
D	X		X	X
C			X	X
B	X	X		X
A		X		X
9	X			X
8				X
7	X	X	X	
6		X	X	
5	X		X	
4			X	
3	X	X		
2		X		
1	X			
0				

Door Lock Switch Codes			
Display Code	Unlocked Switch	Locked Switch	Door Closed Switch
7	closed	closed	closed
6	open	closed	closed
5	closed	open	closed
4	open	open	open
3	closed	closed	open
2	open	closed	open
1	closed	open	open
0	open	open	open

Fault Codes

Fault Code	Problem	Components to Check
F1	Power to element relay energized during time of day display.	J2 harness shorted; If checks ok, change (PRB) power relay board. NOTE: For double oven only, change second oven board.
F2	Over temperature sensed; over 620° sensed by control in time of day mode, bake mode, or over 950° sensed in clean mode.	Ohm SENSOR. If checks ok, change power relay board. "See chart for sensor value."
F3	Cooling fan on with no oven function selected.	Ohm SENSOR, wire harness to sensor.
F4	Shorted oven sensor	Ohm sensor, wire harness to sensor.
F5	Power to element relays disabled in cook mode.	1) Intermittent sensor or wire harness connection. 2) Intermittent contact on PRB.
F7	Shorted key sensed for 32 seconds.	1) Membrane shorted. 2) Display board.
F8	Shorted meat probe alarm.	1) Probe jack or harness to probe jack.
F9	Door lock safety circuit on power relay board.	PRB.
FF	Invalid temperature reading on PRB.	Check sensor and harness, PRB.
F-	Communication error between boards.	1) J2 harness, ohm wires end to end. Harness ok, replace display board.
FC	Communication error between boards.	J2 harness, ok, replace PRB.

Double Oven Only

FR	Second oven error sensed.	1) Check sensor and harness. 2) Replace second oven board.
----	---------------------------	---

MEAT PROBE	
Type: NTC Thermistor	Calibration: 9938 ohms (150°F)
PROBE RESISTANCE VS. TEMP. TABLE	
Degrees F.	Resistance
122	18963 ohms
150	9938 ohms
156.2	8846 ohms
165.2	7456 ohms
210.1	3886 ohms

Cycle Rate For 703650 Infinite Switch		
Setting	% On	Range
Hi	100	100
10	65	62-70
9	50	48-53
8	45	44-47
7	42	39-43
6	35	33-37
5	31	28-32
4	22	21-24
3	19	16-20
2	11	9-13
Lo	6	4-8
Off	0	0

Troubleshooting

Power Board	Voltage	Resistance	Ref. Point	Comments
J1-1	0.0 Vdc	-	J1-1	Signal Ground
J1-2	13.0 Vdc	-	J1-1	+12 Vdc Source
J1-3	21.2 VAC	-	J1-4	T1 Secondary
J2-1	5.0 Vdc	-	J1-1	-
J2-1	0.0 Vdc	-	J1-1	Press Cancel 2
J2-2	5.0 Vdc	-	J1-1	-
J2-2	0.0 Vdc	-	J1-1	Press Cancel 1
J2-3	0.0 Vdc	-	J1-1	Time of Day Mode
J2-3	2.8 Vdc	-	J1-1	Cooking Mode Active Oven 1
J2-4	0.0 Vdc	-	J1-1	Time of Day Mode
J2-4	2.8 Vdc	-	J1-1	Cooking Mode Active Oven 2
J2-5	1.2 VAC	-	J1-1	Serial Clock Line
J2-6	1.3 VAC	-	J1-1	Transmit Line
J2-7	2.5 VAC	-	J1-1	Receive Line
J2-8	-	-	-	Enable Line
J3-1	5.0 Vdc	-	J1-1	Probe Out
J3-1	<3.5 Vdc	-	J1-1	Probe In
J3-2	0.0 Vdc	-	J1-1	Signal Ground
J4-1	12.0 Vdc	-	J1-1	D. Draft OFF or High
J4-1	0.7 Vdc	-	J1-1	Down Draft ON Low
J4-2	12.0 Vdc	-	J1-1	+12 Vdc Source
J4-3	12.0 Vdc	-	J1-1	D. Draft OFF or Low
J4-3	0.7 Vdc	-	J1-1	D. Draft ON High
J5-1	12.0 Vdc	-	J1-1	+12 Vdc Source
J5-2	-	-	-	Open Pin
J5-3	12.0 Vdc	-	J1-1	Door 1 Closed
J5-3	0.0 Vdc	-	J1-1	Door 1 Open
J5-4	0.0 Vdc	-	J1-1	Door 1 Unlocked
J5-4	12.0 Vdc	-	J1-1	Door 1 Locked
J5-5	12.0 Vdc	-	J1-1	Door 1 Unlocked
J5-5	0.0 Vdc	-	J1-1	Door 1 Locked
J7-1	-	-	-	Enable Line
J7-2	-	-	-	Open Pin
J7-3	2.5 VAC	-	J1-1	Receive Line

Power Board	Voltage	Resistance	Ref. Point	Comments
J7-4	2.8 Vdc	-	J1-1	Door Lock Limit
J7-5	0.0 Vdc	-	J1-1	Time-of-Day Mode
J7-5	2.3 VAC	-	J1-1	Cooking Mode Active Oven 2
J7-6	1.2	-	J1-1	Serial Clock Line
J7-7	0.0 Vdc	-	J1-1	Time-of-Day Mode
J7-7	2.8 Vdc	-	J1-1	Cooking Mode Active Oven 2
J7-8	0.0 Vdc	-	J1-1	Signal Ground
J8-1	12.0 Vdc	-	J1-1	+12 Vdc Source
J8-2	12.0 Vdc	-	J1-1	Door 1 Closed
J8-2	0.0 Vdc	-	J1-1	Door 1 Open
J8-3	0.0 Vdc	-	J1-1	Door 1 Unlocked
J8-3	12.0 Vdc	-	J1-1	Door 1 Locked
J8-4	-	-	-	Open Pin
J8-5	12.0 Vdc	-	J1-1	Door 1 Unlocked
J8-5	0.0 Vdc	-	J1-1	Door 1 Locked
J9-1	1.9 Vdc	-	J1-1	Oven Probe
J9-2	-	-	-	Open Pin
J9-3	<3.5 Vdc	-	-	Cool Oven
J10-1	-	-	-	Open Pin
J10-2	<3.5 Vdc	-	-	Cool Oven
J10-3	1.9 Vdc	-	J1-1	Oven Probe

Down Draft	Voltage	Resistance	Ref. Point	Comments
J4-1	12.0 Vdc	-	J1-1, MPB	D. Draft OFF or High
J4-1	0.7 Vdc	-	J1-1 MPB	Down Draft ON Low
J4-2	12.0 Vdc	-	J1-1, MPB	+12 Vdc Source
J4-3	12.0 Vdc	-	J1-1, MPB	D. Draft OFF or Low
J4-3	0.7 Vdc	-	J1-1, MPB	D. Draft ON High

Control Head	Voltage	Resistance	Ref. Point	Comments
J1-1	0.0 Vdc	-	J1-1	Signal Ground
J1-2	13.0	-	J1-1	+12 Vdc Source
J1-3	21.2 VAC	-	J1-4	T1 Secondary
J2-1	5.0 Vdc	-	J1-1	-
J2-1	0.0 Vdc	-	J1-1	Press Cancel 2
J2-2	5.0 Vdc	-	J1-1	-
J2-2	0.0 Vdc	-	J1-1	Press Cancel 1
J2-3	0.0 Vdc	-	J1-1	Time-of-Day Mode
J2-3	2.8 Vdc	-	J1-1	Cooking Mode Active Oven 1
J2-4	0.0 Vdc	-	J1-1	Time-of-Day Mode
J2-4	2.8 Vdc	-	J1-1	Cooking Mode Active Oven 2
J2-5	1.2 VAC	-	J1-1	Serial Clock Line
J2-6	1.3 VAC	-	J1-1	Transmit Line
J2-7	2.5 VAC	-	J1-1	Receive Line
J2-8	-	-	-	Enable Line

2nd Oven	Voltage	Resistance	Ref. Point	Comments
J7-1	-	-	-	Enable Line
J7-2	-	-	-	Open Pin
J7-3	2.5 VAC	-	J1-1	Receive Line
J7-4	2.8 Vdc	-	J1-1	Door Lock Limit
J7-5	0.0 Vdc	-	J1-1	Time of Day Mode
J7-5	2.3 VAC	-	J1-1	Cooking Mode Active Oven 2
J7-6	1.2 VAC	-	J1-1	Serial Clock Line
J7-7	0.0 Vdc	-	J1-1	Time-of-Day Mode
J7-7	2.8 Vdc	-	J1-1	Cooking Mode Active Oven 2
J7-8	0.0 Vdc	-	J1-1	Signal Ground

Multiplexing Circuitry-SVE47600

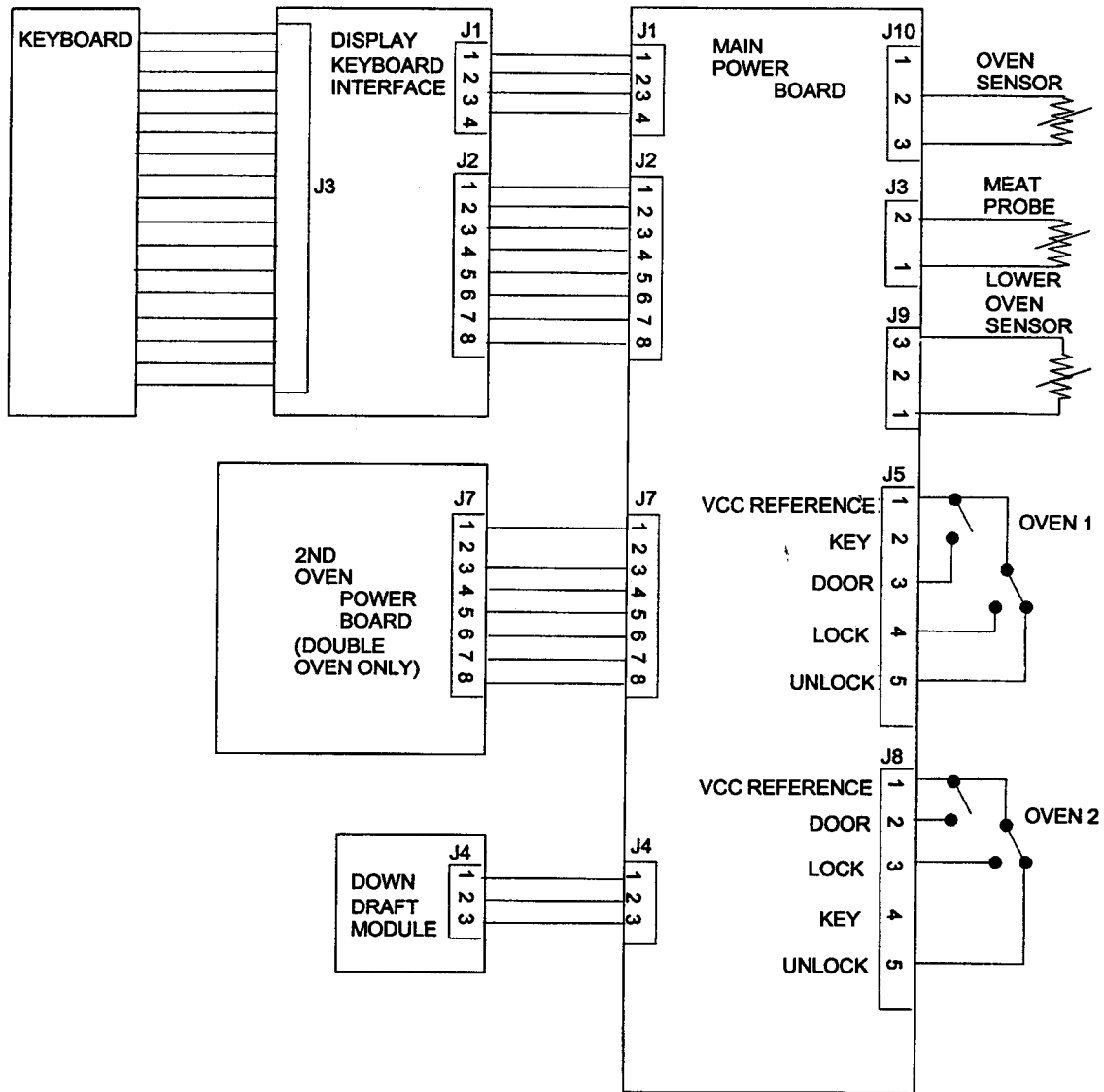

Power Relay Board Connections - SVE47600

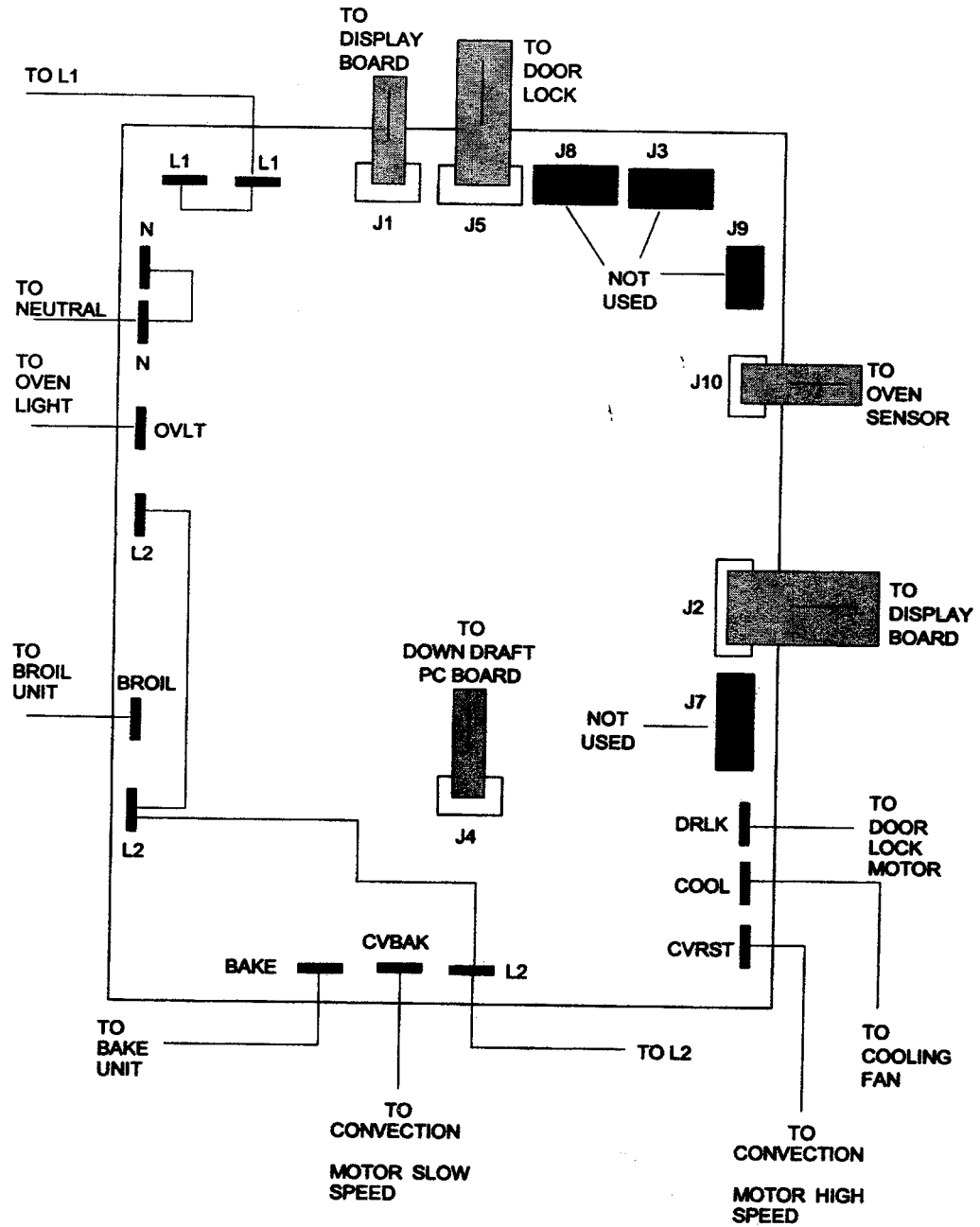

Display Board Connections - SVE47600

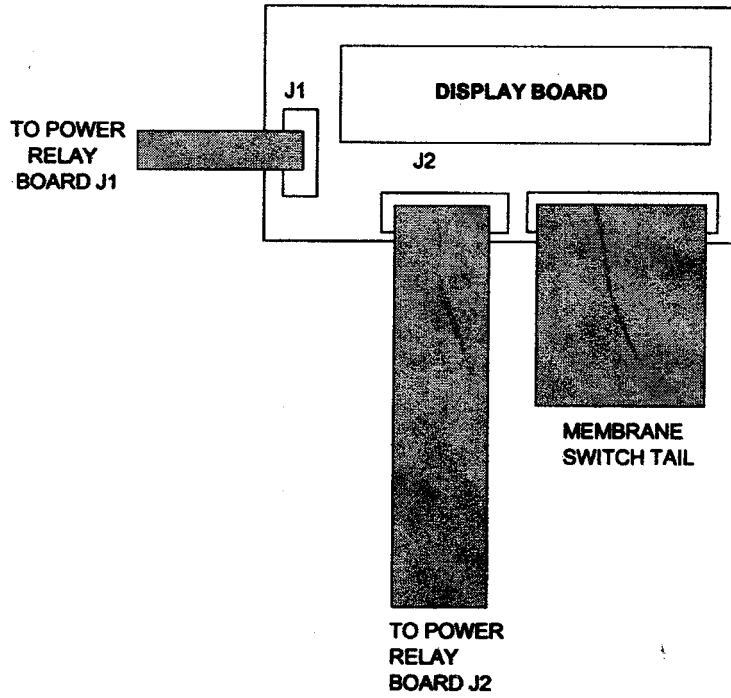

Down Draft Board Connections - SVE47600

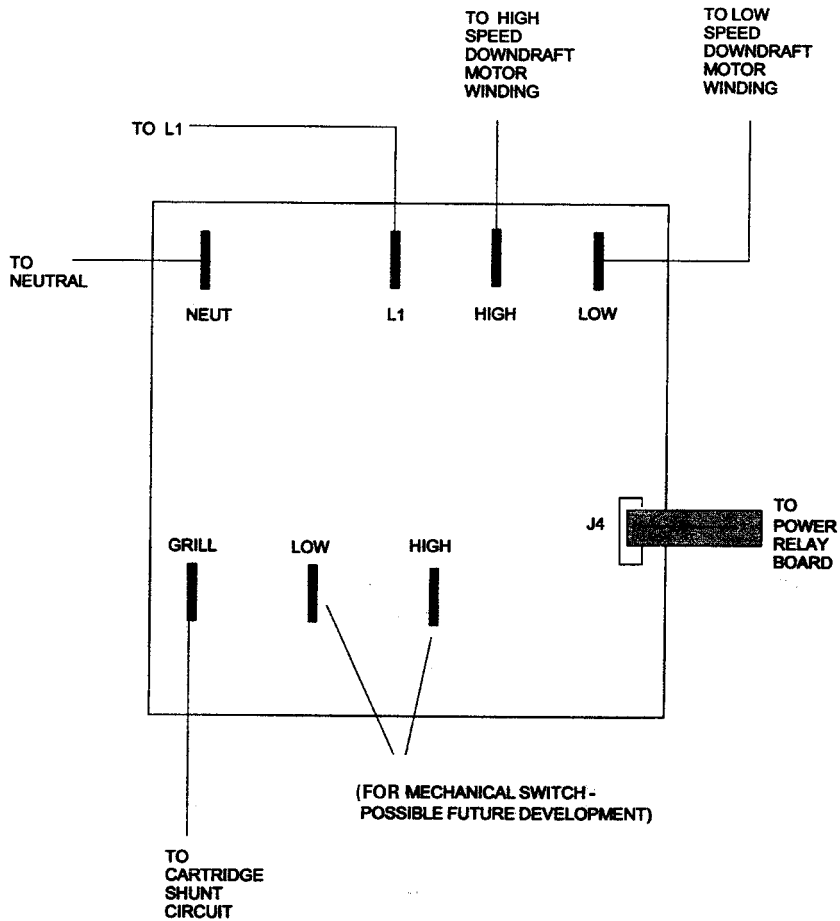

Circuit Board Connections - SVE47600

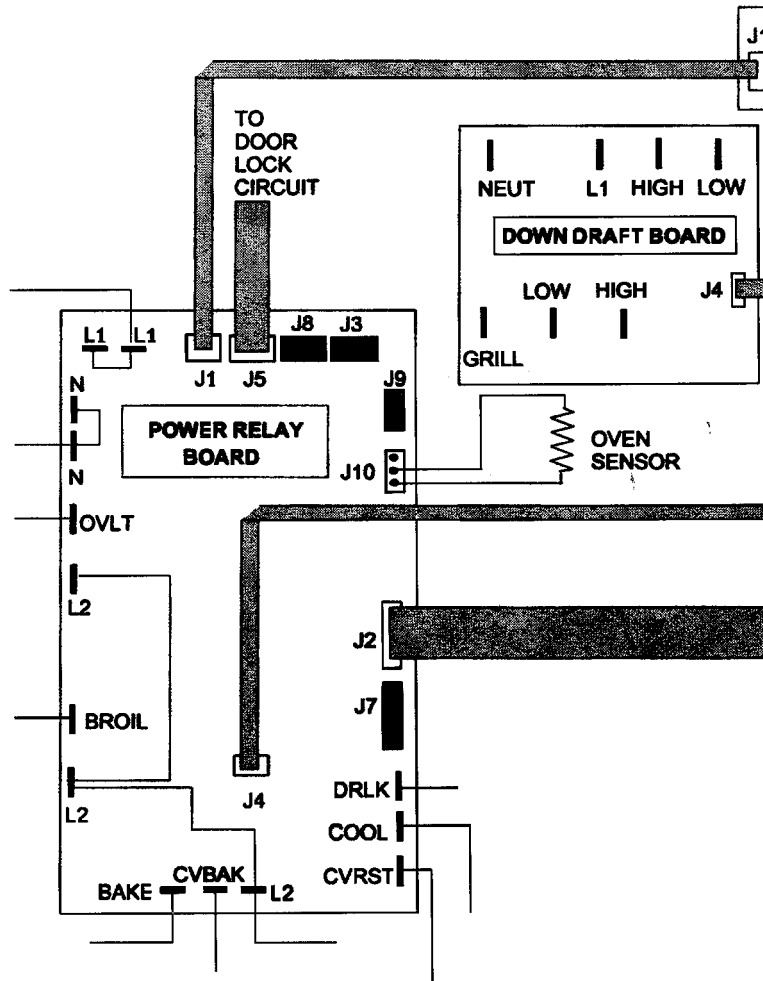

Circuit Board Connections - SVE47100

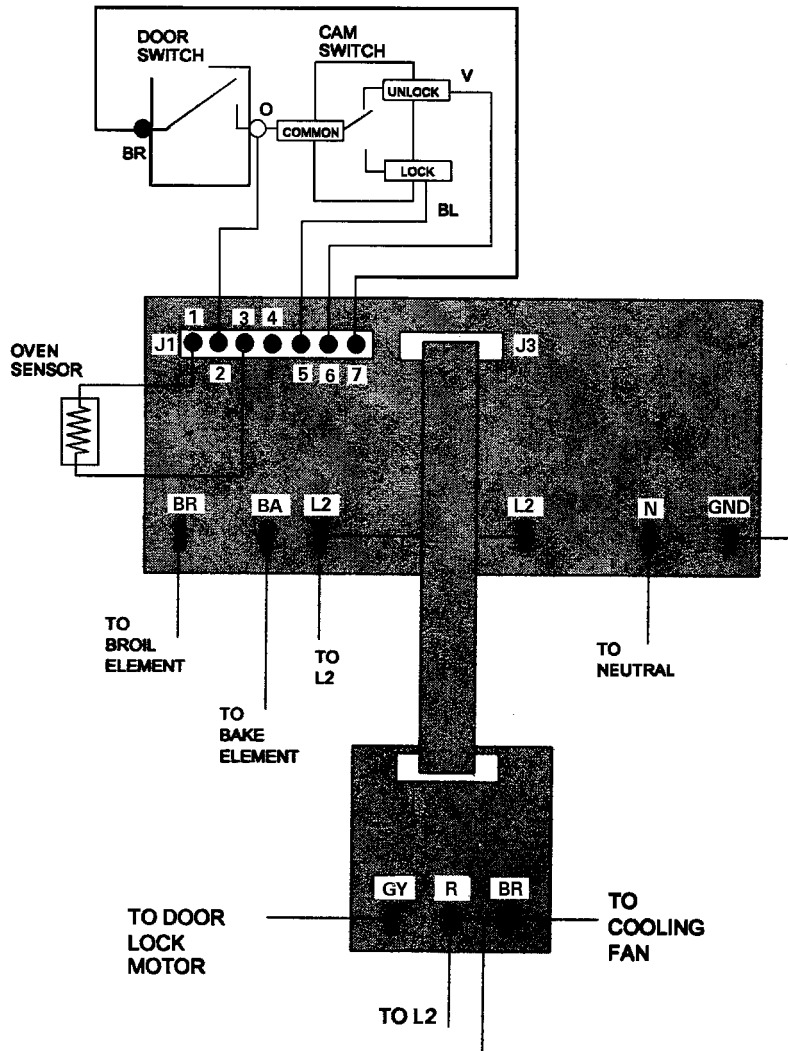

Temperature Bands Chart - SVE47100

	Band 1 100° - 199°F		Band 2 199° - 298°F			Band 3 298° - 399°			Band 4 399° - 550°				
Preheat (1st Rise)	Proofing * (Bake W/Temp Setting Below 199°F)	Drying * (Either Convect Mode W/Temp Setting Below 199°F)	Bake	Convect Bake *	Convect Roast *	Bake	Convect Bake *	Convect Roast *	Bake	Convect Bake *	Convect Roast *	Broil	Clean
Broil Element	18 sec.	0 sec.	7 sec.	0 sec.	0 sec.	7 sec.	0 sec.	0 sec.	7 sec.	0 sec.	0 sec.	None	None
Bake Element	18 sec.	0 sec.	51 sec.	0 sec.	0 sec.	51 sec.	0 sec.	0 sec.	51 sec.	0 sec.	0 sec.		
Temp Set	100°F	0°F	250°F	0°F	0°F	325°F	0°F	0°F	425°F	0°F	0°F		
On Temp	90°F	0°F	235°F	0°F	0°F	315°F	0°F	0°F	415°F	0°F	0°F		
Off Temp	95°F	0°F	245°F	0°F	0°F	325°F	0°F	0°F	430°F	0°F	0°F		
Convect Fan	NO	HI (conv. roast)	NO	NO	NO	NO	NO	NO	NO	NO	NO		
Cook (After 1st Rise)													
Broil Element	18 sec.	0 sec.	3 sec.	0 sec.	0 sec.	3 sec.	0 sec.	0 sec.	3 sec.	0 sec.	0 sec.	60 sec.	31 sec.
Bake Element	18 sec.	0 sec.	46 sec.	0 sec.	0 sec.	46 sec.	0 sec.	0 sec.	46 sec.	0 sec.	0 sec.	0 sec.	21 sec.
Temp Set	100°F	0°F	250°F	0°F	0°F	325°F	0°F	0°F	425°F	0°F	0°F	550°F	----
On Temp	90°F	0°F	235°F	0°F	0°F	315°F	0°F	0°F	420°F	0°F	0°F	545°F	895°F
Off Temp	95°F	0°F	245°F	0°F	0°F	325°F	0°F	0°F	430°F	0°F	0°F	555°F	905°F
Convect Fan	NO	HI (conv. roast)	NO	NO	NO	NO	NO	NO	NO	NO	NO	NO	NO

*If equipped

Membrane Connections - SVE47600 & SVE47500

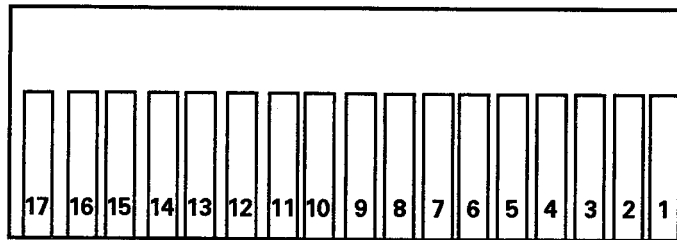

PAD	CIRCUIT
1	15 to 4
2	14 to 4
3	13 to 4
4	12 to 4
5	11 to 4
5	10 to 4
7	9 to 4
8	8 to 4
9	7 to 4
0	6 to 4
TIMER ONE	14 to 5
STOP TIME	13 to 5
CLOCK	12 to 5
NO CONTACT	11 to 5
OVEN LIGHT	10 to 5
TIMER TWO	9 to 5
COOK TIME	8 to 5
FAN	7 to 5
BAKE	10 to 3
BROIL	9 to 3
CLEAN	8 to 3
*CONV BAKE	7 to 3
*CONV ROAST	6 to 3
CANCEL	1 to 2

*Not used on SVE47500 Models

Membrane Switch: The means to make a switch contact, instructing the electronic control system to perform a desired function. The membrane switch is a simple set of two contact surfaces containing conductive material, one on the back layer of MYLAR and the other on the front layer of MYLAR. There is also a center section of

non-conductive MYLAR material that has a hole punched out of it at each switch contact position. The thickness of the MYLAR spacer determines the push force required to close the contacts between the front contact strip and the rear contact strip. Typically, the push force required to close a contact is 12 to 18 ounces.

ESC Keyboard Diagram - SVE87600

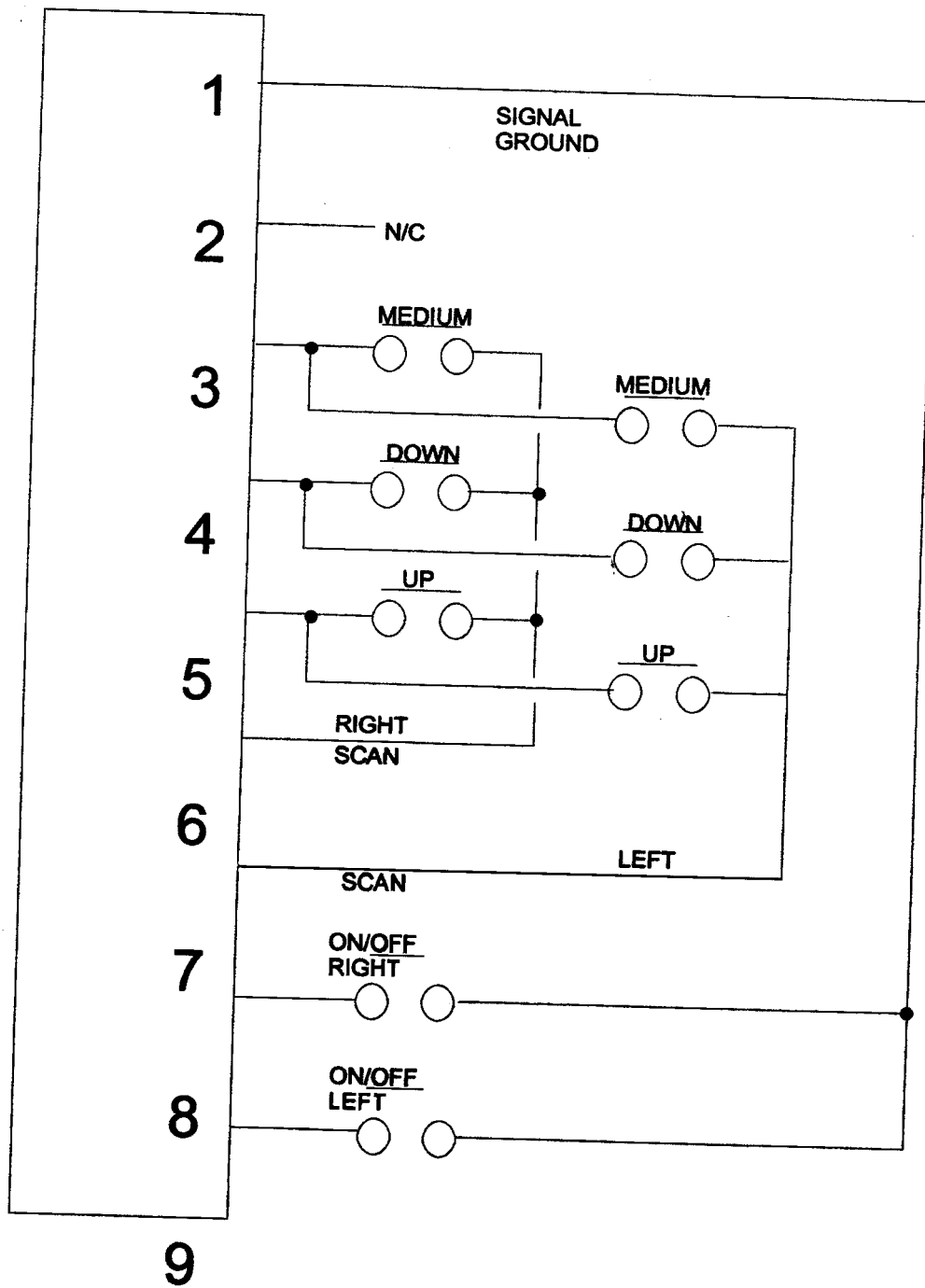

Electronic Surface Control - SVE87600

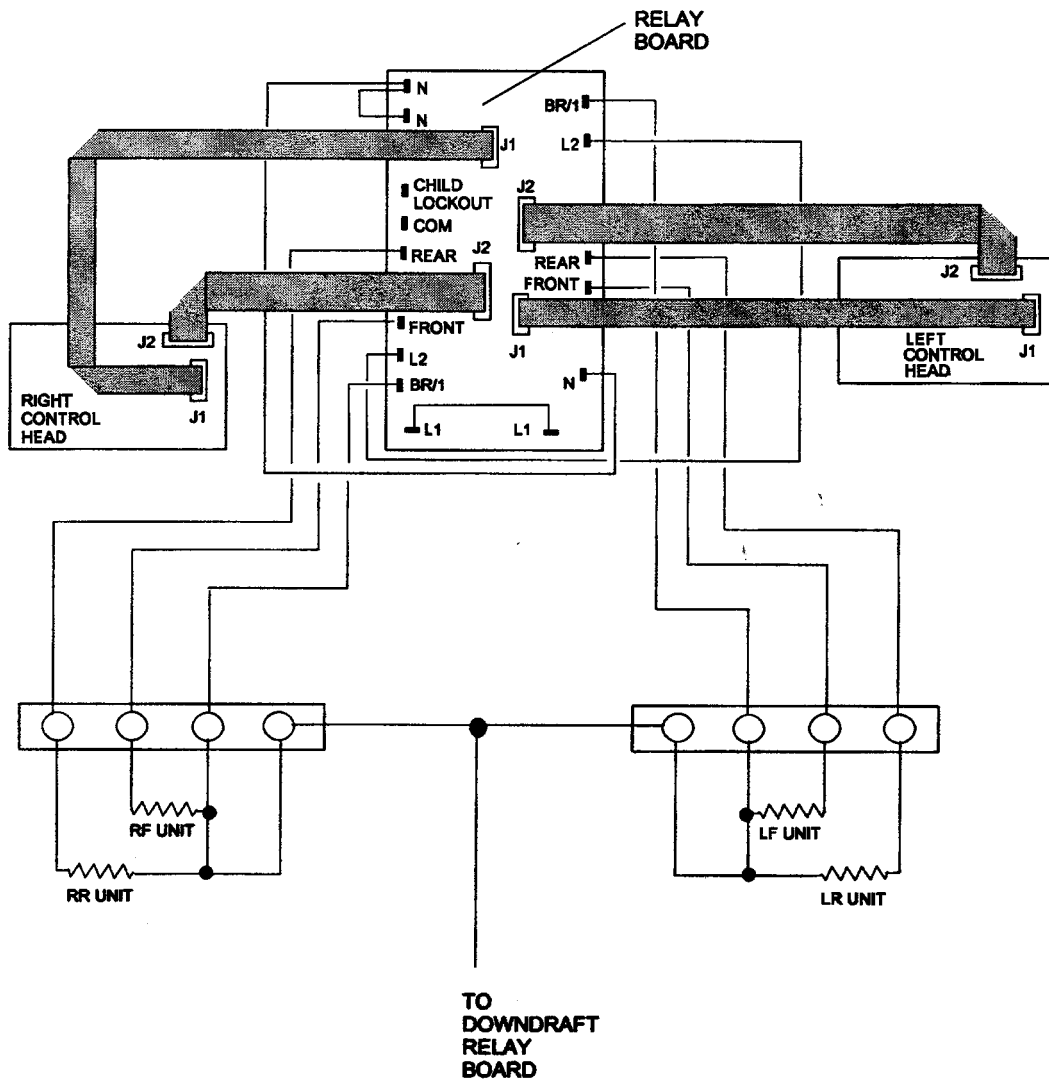

Circuit Board Connections - SVE87600

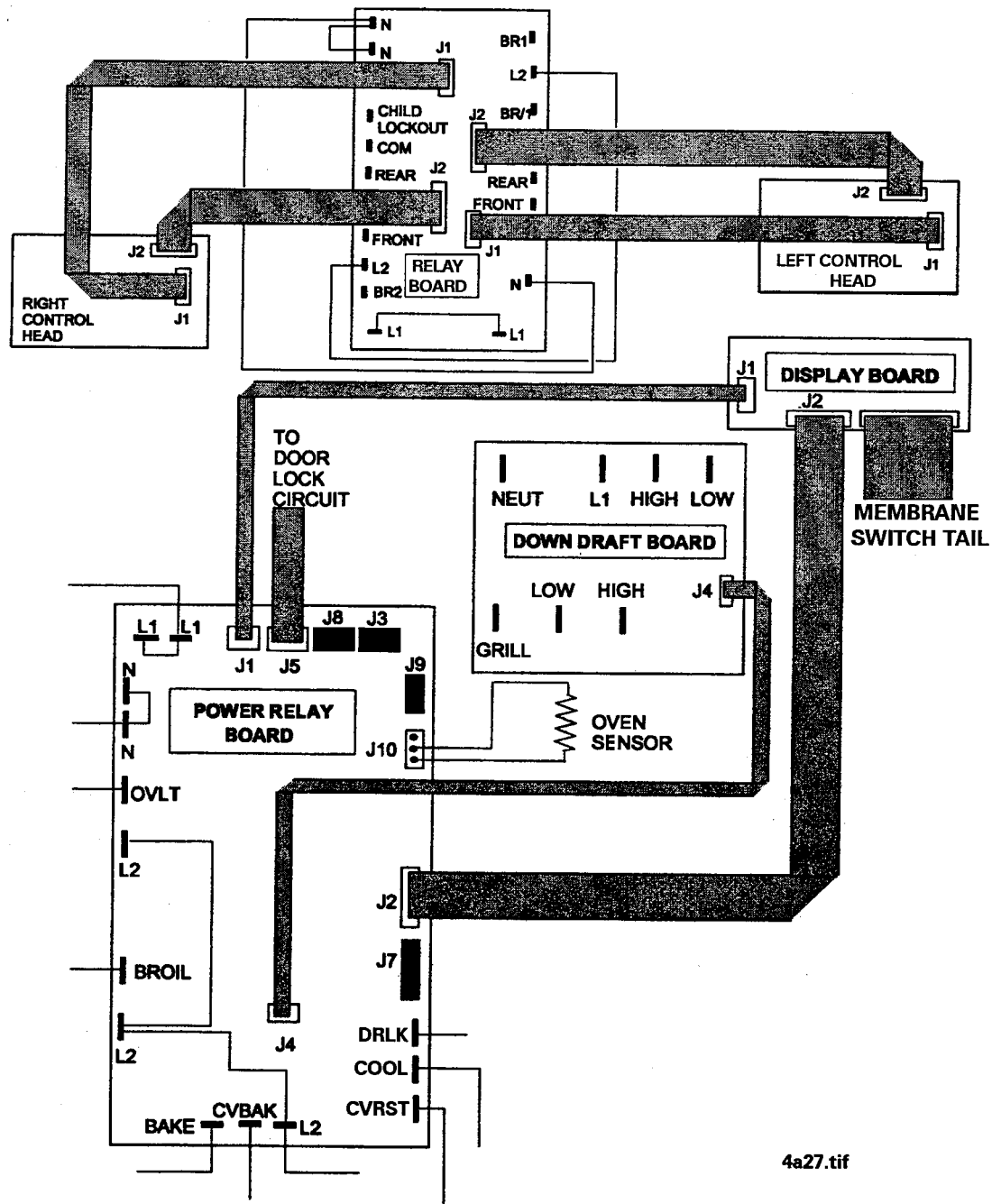

4a27.tif

Test Equipment

Electrical Test Equipment

The equipment required to service Maytag products depends largely upon the conditions you encounter. Locating a malfunction will often require the use of electrical testing equipment such as:

<u>Description</u>	<u>Part Number</u>
Analog Test Meter	2000005
Digital Test Meter	20001001
Clamp-On Ammeter	20000002
AC Voltage Sensor	20000081
Digital Multimeter	20001006
Digital Watt/Amp/Volt/ Ohm/Temp. Meter	20000019
Dwyer Air Meter	20000029

Analog Test Meter can be used to check for open or closed circuits, measure resistance, AC and DC volts, and temperature.

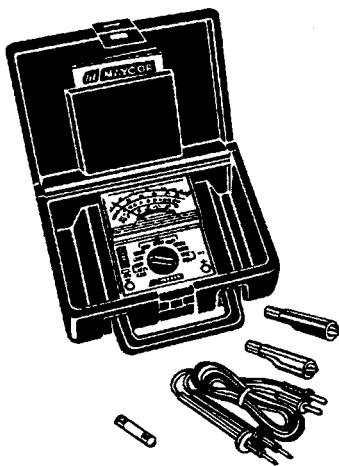

AC Voltage Sensor can be used to alert you if AC voltage is present so proper safety precautions can be observed. The tip of the sensor will glow bright red if voltage is between 110-600 volts AC.

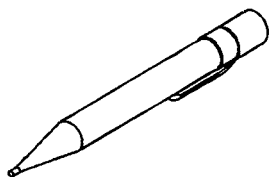

Clamp-On Ammeter can be used to detect shorts. Overloads on the circuit breaker or fuse can be traced to either the appliance or circuit breaker by checking the appliance current draw.



Digital Test Meter can be used to check for open or closed circuits, measure resistance, AC and DC volts, and temperature.



Digital Multimeter features easy-to-read LCD display and tilt stand. Reads AC voltage to 500V and DC voltage to 1000V, battery test, up to 10 amps and 2 meg-ohms of resistance.

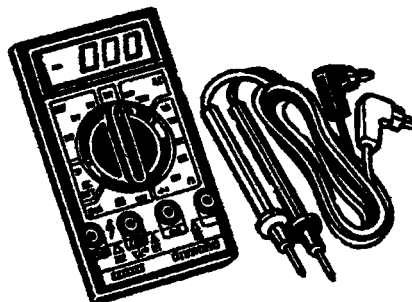

Digital Watt/Amp/Volt/Ohm/Temp. Meter measures power (wattage), AC/DC volts, AC/DC amps, temperature (C&F) Ohms resistance, continuity and capacitance. Features large LCD display with backlight and analog bar graph to show tendencies.

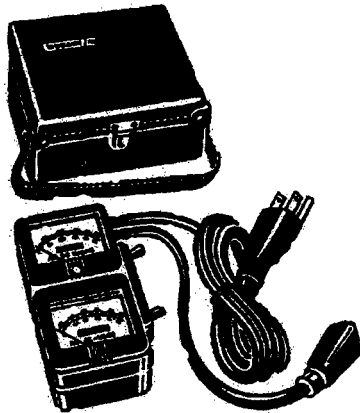

Dwyer Air Meter is used to diagnose restricted vents. A precision air velocity and static pressure indicator based on the principle of the variable area flowmeter.

DWYER

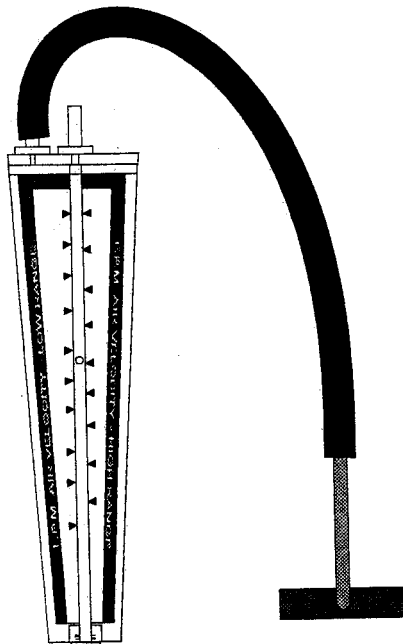

Ventilation Test

All downdraft models being produced today come with a test card insert in the user's material. **(This drawing is not to size, for illustration only!)** This test card is a quick way to test operation of the ventilation system. Although a part number is listed, it is not an individual part. The card is placed over the intake (with all accessories and air grille removed) and the blower started. If it falls in, the air velocity should be OK. This test is not a replacement for using proper instruments. It only provides installers with initial testing for those who do not have proper instruments. **NOTE: Air filter must be in place to prevent card from going into the blower wheel!**

FLOW TESTER

↑
This end of tester to be positioned over air intake.

For Cooktop models use this side of line. ↓



For Range models use this side of line. ↑

How to use this tester to check your downdraft system:

- 1) Remove all cartridges, accessories and the air grille from unit.
- 2) Insure the air filter is in place.
- 3) Align the edge of dotted line that corresponds to unit being tested with the edge of the intake on the left side of the unit near the center. (see diagram)

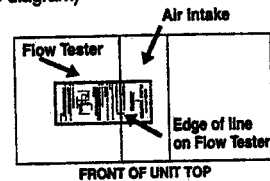

- 4) Turn on the downdraft system.
- 5) If the card is pulled into the air intake your downdraft system is working properly.
- 6) If the card is not pulled into the system see installation instructions for possible causes.

PART NO. 210305A

Ducting

Air movement is measured in two ways. CFM or FPM (cubic feet per minute) is the measurement of total air VOLUME and is also known as exhaust air. FPM (feet per minute) is the measurement of air VELOCITY. All testing of Jenn-Air downdrafts should be performed using FPM measurements. Use the following formula to determine the FPM:
 $CFM = FPM \times \text{Free Area in square feet.}$

Example:

***750 FPM X a register measure
12" by 12" (1 sq. Foot) = 750 CFM
(or CFM = Ak X Vk)***

Downdraft ventilation is a high velocity system (750 - 1025 F. P. M.). It is designed to move air quickly and to hold grease, moisture and fumes in suspension as air moves through the ducting. Too little air movement means a smoke filled kitchen. Too much air movement means cooled off food and prolonged cooking times. The type of material used affects the performance. Inferior material can cause up to twice the amount of restriction.

If the system does not capture both cooking fumes and smoke while grilling; these are some ducting installation situations to check:

- 6" diameter round or 3 1/4" X 10" rectangular only, ducting of at least 26 gauge aluminum should be used. Except as follows: For Electric Models, 5" diameter round ducting may be used for venting straight out the back of the range and directly through the wall for 10 feet or less. For Gas Models with Electric Ovens, 5" diameter round must be used if the duct length is 10 feet or less.

- Distance between adjacent fittings should be at least 18". The farther the better. Closer distance promotes turbulence which reduces airflow.
- Recommended Jenn-Air wall cap should be used. Make sure damper moves freely when ventilation system is operating.

If there is not an obvious improper installation, there may be a concealed problem such as a pinched joint, obstruction in the pipe, etc. ***Installation is the responsibility of the installer*** and questions should be addressed first by the installer. The installer should very carefully check the ducting installation instructions.

Restrictions

Restrictions in the ducting are one of the greatest causes for poor performance. Restrictions commonly cause the overload protector of the blower motor to open after 20 minutes of operation. Technicians need to be well versed and need to easily identify the many types of restrictions encountered.

One of the most common restrictions is when two elbows are connected back to back. This configuration causes turbulence in the air stream which carries far down the duct before it recovers. It is recommended that 2 1/2 times the outside diameter of duct be placed in between elbows to prevent this turbulence. Example - 6" duct X 2 1/2 = 15 inches between elbows.

- Handmade crimps are likely to cause restrictions. Improper crimps result in the reduction of inside diameter. Air flow should always come from the male side of connections.

- The reduction of duct size also causes restriction. Never go from a larger size duct to a smaller size.
- All transitions should be tapered. Do not use untapered elbows or transitions.

A service representative can measure the air velocity (FPM - feet per minute) at the grill surface to determine if it meets the requirement for the appliance (the FPM differs from grill-ranges and cooktop models). The grill-range model is rated at 60 feet of straight duct, low ranges is up to 30 feet - high range is 31 to 60 feet.

Ventilation System

The ventilation system is either two speed or one speed depending on the model. When grilling, the motor always defaults to high speed. On two speed models, one push on the fan button starts the ventilation motor on high, the second push switches the motor to low. There is a five second delay in switching from high to low. This protects the motor by allowing it to obtain momentum before using the slow speed winding.

Blower & Convect Assembly Parts List

1. Bracket, Mount
2. Locknut, Bracket
3. Cover, Motor
Screw, Motor Cover
4. Stop, Filter
5. Motor
Foam, Urethane
6. Band, Motor
7. Ring, Restrictor
8. Filter, Grease
9. Isolator (nut & screw)
10. Wheel, Blower
11. Scroll, Blower Assy.
12. Ring, Inlet
13. Adapter. Restrictor Ring
14. Clamp, Hose
15. Duct, Flexible
16. Retainer
17. Plenum (upper), & clip
18. Cover, Vent
19. Screw, Vent Cover
20. Plenum (lower)
21. Cord, Motor
22. Convect Motor Assy.
23. Wheel, Convect Assy.
24. Plate, Convection (front)
25. Screw, Plate (& washer, plate)

NOTE: Select models have certain features.

Blower & Convect Assembly Illustration

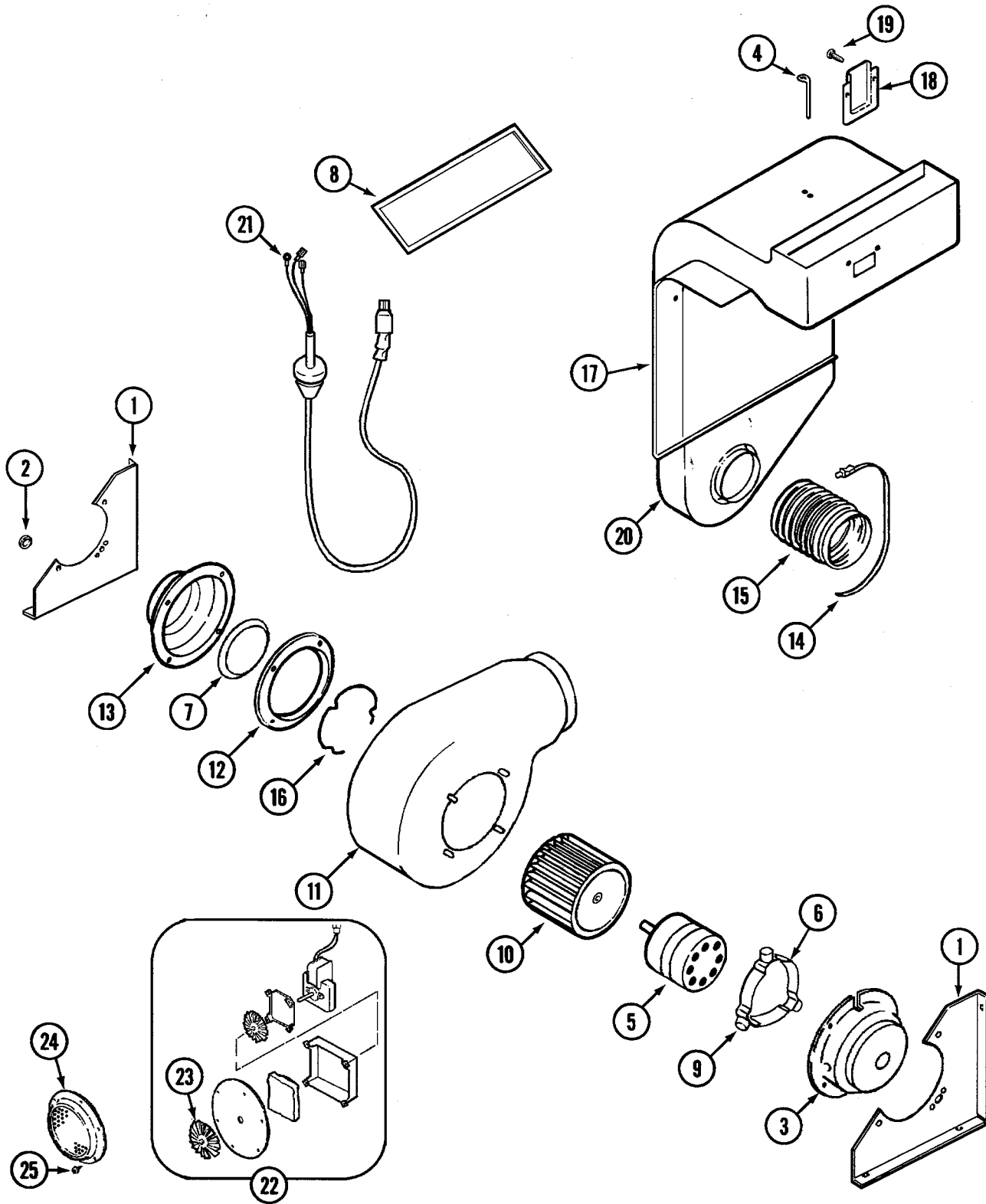

NOTE: Select models have certain features.

Section 2. General Component Access

Getting Started

As a general rule, the appliance should ALWAYS be disconnected from the power source and the gas supply turned off before servicing appliance or replacing component parts. Failure to disconnect the power and turn off gas supply increases the likelihood that a servicing error or mistake will result in serious or fatal injuries.

Serviceable repairs can be performed on Slide-In units from the front. Most components are accessible, testable, serviceable and can be completed from the front of the range as well. The exceptions to front serviceability include the oven circuit board and the down draft circuit board.

Raise the range off the countertop (Slide-In installations) before removing the range from the cabinets to avoid countertop damage; otherwise the range may chip the countertop as it drops off. This may be accomplished by removing the access panel or lower door panel (depending on model) and turning the leveling legs out to raise the range.

If the unit is to be removed from its installation position, first disconnect power to unit and turn off gas supply before attempting service. Disconnect blower power cord on the range to the blower and remove the flex ducting to the blower and range (depending on model). When reinstalling the unit, verify that the rear leveling legs have been fully inserted into and secured properly by the Anti-Tip brackets.

Cartridges

Cooktop cartridges, either conventional coil, halogen, radiant or solid element, can be installed on either side of the range.

To remove cartridges:

1. Controls must be OFF and the cartridge should be cool.
2. Lift up on the "tab" located on the cartridge until top of cartridge clears the opening on the range by about 2 inches. Lifting the cartridge too high while still engaged in the receptacle could damage the terminal plug.
3. To disengage terminal, hold cartridge by the sides and slide away from the terminal receptacle. Lift out when fully unplugged.

Accessories

All parts of the cartridges are replaceable. Schematics for cartridges differ from cartridge to cartridge. Older cartridges utilized four blades, while current ones utilize three, with one of the prongs being common to both elements. Older cartridges may be converted to the three blade style if the technician is familiar with wiring configurations. The old style cartridge used all four prongs to connect the two elements. The newer three prong cartridges have been in production for about 10 years. The shunt to the fourth prong on current cartridges is not used for the cooktop elements. The shunt to the fourth prong is used on the grille elements to bring the downdraft fan motor into the circuit automatically, whenever the infinite switch is turned on. This feature is not needed for the cooktop elements.

Accessories & Cartridge Conversions

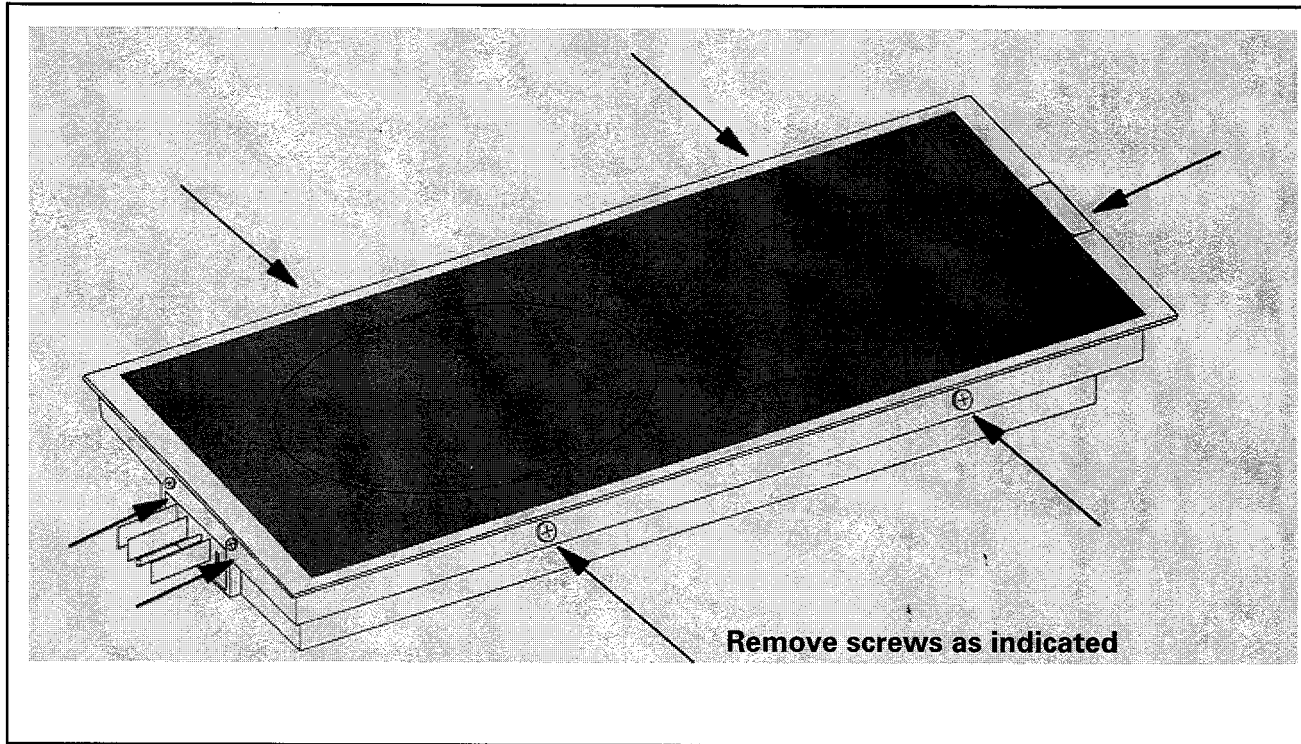

New 3 Blade Cartridge

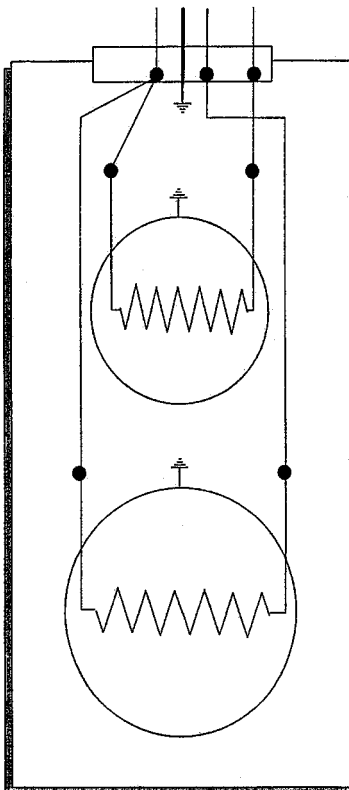

Old 4 Blade Cartridge

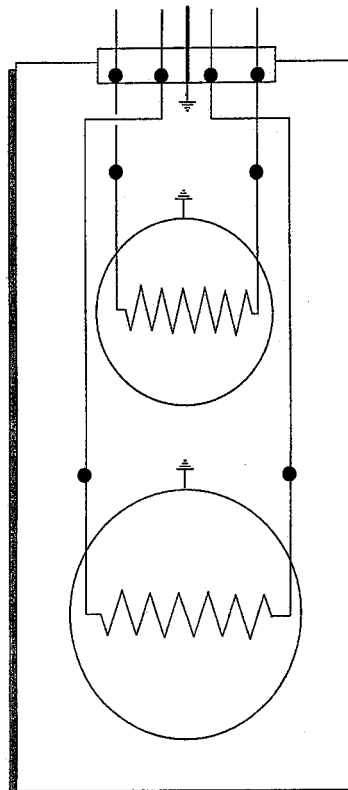

Door Assembly

The following are instructions to access, repair and replace door components of the slide-in range.

IMPORTANT

**DISCONNECT FROM POWER SOURCE
BEFORE SERVICING APPLIANCE.**

Oven Door

1. Open the oven door as wide as possible.
2. Insert a small 1/8" diameter pin (8d penny nails or 1/8" drill bit) through the hole on the right and left door hinges to hold the hinge open.

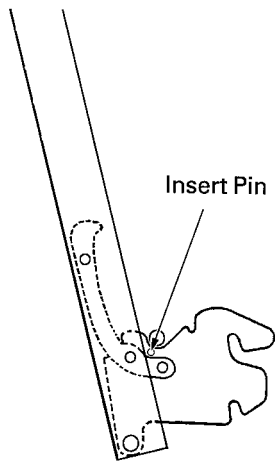

SC006TIF

3. Remove the two phillips head screws holding the hinge retainer plate and hinge cover plate on the oven front frame, just above the hinge arm, left & right side. Set aside for later to reinstall.
4. Raise the oven door up to a broil stop position. In this position, it will be against the 1/8" diameter pins.
5. Grasp the door toward the top on both sides. Lift the door up and out to remove.

NOTE: The hinge remains in the door.

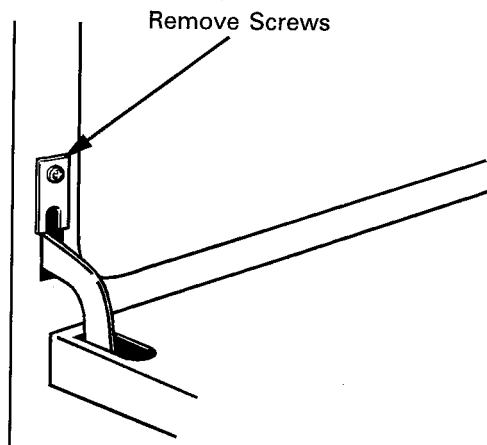

SC051TIF

Oven Door Handle

1. Lay the oven door on a protected surface with the inner door panel facing down.
2. Remove three (3) screws from lower trim. Remove trim piece.
3. Slide outer-door glass down to disengage from top trim. Lay aside.

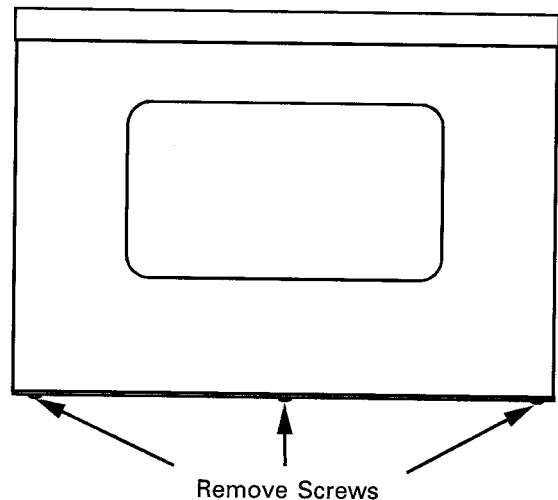

SC052TIF

4. Remove three (3) screws that hold the top trim in place on oven door. Remove the two 3/8" hex nuts from the door handle bracket.
5. Lift up and off. The door handle, top trim and two brackets may be removed as one assembly. This will disengage the side trim as well.
6. To replace the door handle, remove the two phillips screws and two 3/8" hex nuts securing the handle to the top trim assembly.

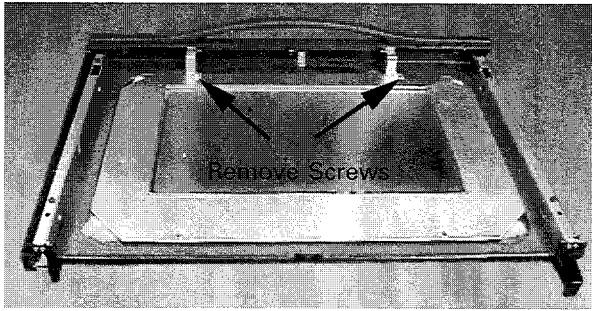

7. Gain access to the oven window pack by removing the remaining 3/8" nuts from the insulation retainer.

8. To reassemble the oven door, reverse the procedures for disassembling.

Oven Door Hinge Replacement

1. Remove two (2) screws from oven inner door panel that mount into the lower portion of oven door hinge assembly.

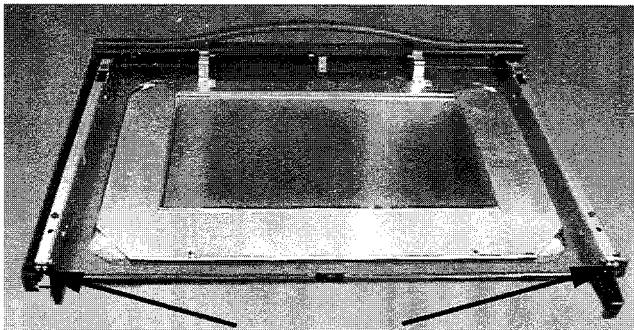

Remove Screws

2. Grasp and lift oven door hinge assembly upward and slide down to disengage upper tabs from the door panel.

3. To reassemble the oven door, reverse the procedures for disassembling.

Oven Door Gasket

The oven door gasket is held in place with clips and can be removed by gently pulling the gasket away from the inner door panel. Begin by pulling gasket out of the hole at the bottom of inner door liner. Grasp the oven gasket clips with needle nose pliers and gently pull each clip away from inner door. To replace gasket, start at the bottom of liner

and tuck one end of the oven door gasket into opening in the inner door panel and work around the liner inserting the clips. When complete, tuck the end of the gasket into the opening.

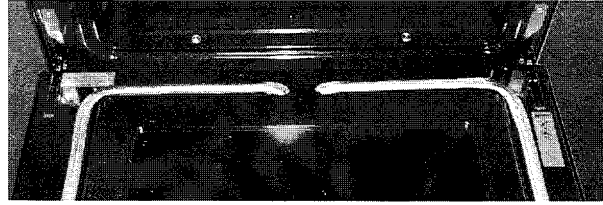

Oven Hinge Pockets

1. Remove oven door following the steps previously described in section on Oven Door Removal.

2. Remove hex screws from the lower front closure.

3. From each side of the range, remove two 1/4" hex screws.

4. Replace components and reassemble.

Oven Door (SVD8310S)

To remove lift-off door:

1. Open door to broil stop position.

2. Grasp the sides of the door and lift up.

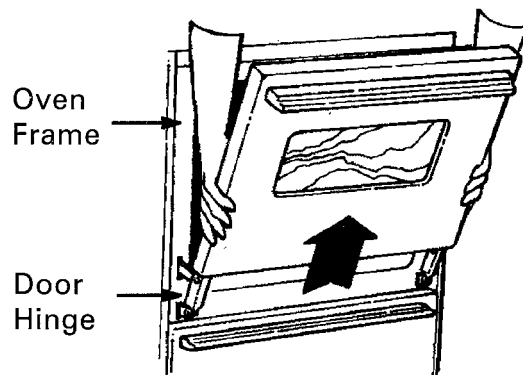

IMPORTANT

Do not use handle to lift the oven door. Lifting the door by the handle may cause damage to the door.

To replace lift-off door:

1. Grasp door at each side.
2. Align slots in door with hinge arms on range.
3. Slide the door down until the door is completely seated on the hinges.

To service door:

1. Remove three (3) phillips screws from the bottom of the door.
2. Remove two (2) phillips screws from sides of door.

3. Slide metal frame and glass down until the frame and glass clear the plastic top trim.
4. Interior of the door is now accessible.

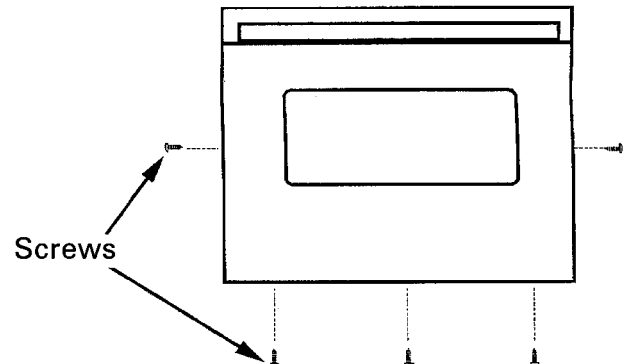

Oven Components

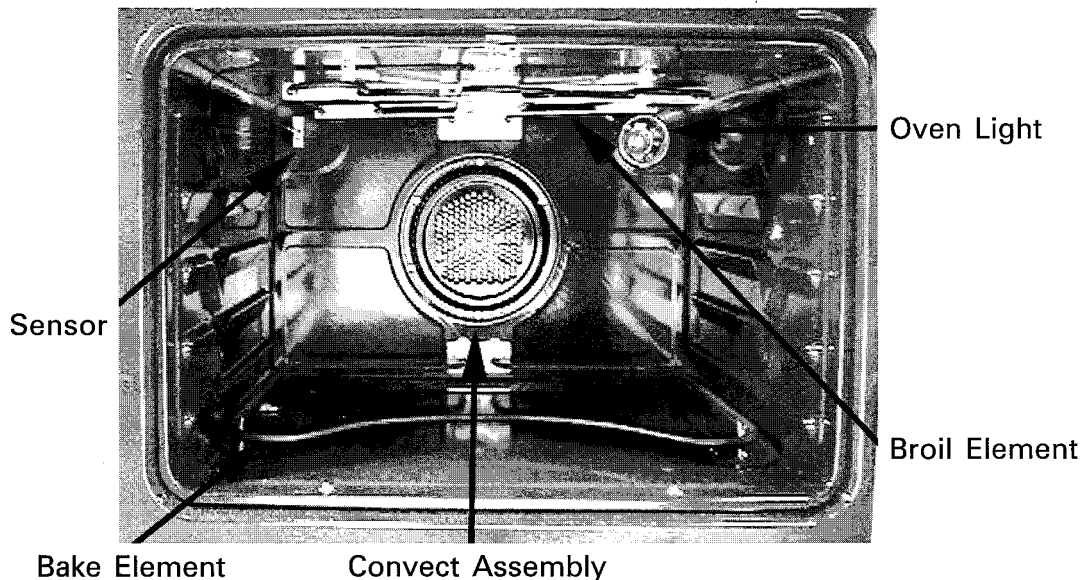

Oven cavity components consist of: Bake and broil elements, oven light assembly, convection motor, oven cavity, smoke eliminator, temperature probe, regulator, and oven sensor.

IMPORTANT

**DISCONNECT FROM POWER SOURCE
BEFORE SERVICING APPLIANCE.**

Bake Element Removal

Remove the two (2), 1/4" screws. Pull the bake element into the oven cavity to access electrical wiring.

Resistance check - approximate 20 Ohms.

Broil Element Removal

Remove the four (4), 1/4" hex screws. Pull broil element into oven cavity to gain access to the electric wiring. Reattach by returning to the original position and fastening with four (4) hex screws.

Resistance Check - approximate 16 Ohms.

Oven Light

Bulb can be replaced or accessed by turning the lens counterclockwise to remove the entire oven light. The socket can be removed by depressing the spring clips from the rear

of the light socket and pushing it into the oven cavity. Replace with a 40 watt bulb.

A new oven light socket can be inserted and snapped into position by depressing the spring clips and reattaching in the original position. Replace with a 40 watt oven-rated appliance bulb. Bulb with brass base is recommended to prevent fusing of bulb to socket.

Oven Light (SVD8310S)

Carefully remove the glass light lens and lens retainer by removing the two (2) screws in the light lens retainer using a phillips screwdriver.

NOTE: The light lens is separate from the light lens retainer. The two pieces will drop down into your hands at the same time. Remove the remaining two screws to replace the light receptacle. Replace with a 40 watt oven-rated appliance bulb. Bulb with brass base is recommended to prevent fusing of bulb to socket.

Oven Vent/Smoke Eliminator

1. Remove oven vent and smoke eliminator by using tabs on bottom of smoke eliminator, turning counterclockwise to disengage the locking ears from the inner insulation retainer.
2. To remove the smoke eliminator, pull down and align locking ears with notches in oven cavity.
3. Reattach by reversing above procedures.

Oven Cavity

1. All internal oven cavity components must be removed prior to oven cavity removal.
2. Remove the five (5), 1/4" hex screws from the front flange of the oven liner. (Three (3) screws will be on the top and two on the bottom.)
3. Grasp the front flange of the oven liner and gently pull forward to remove oven liner from insulation and structure.

NOTE: When replacing oven cavity, use pieces of sheet metal on sides and top of oven liner to allow cavity installation without tearing or removing insulation.

When the cavity is within two inches of being in place, remove the sheet metal.

Convection Motor Assembly

To access the motor assembly, remove the three (3), 1/4" hex screws from the convect cover. Remove the cover. Remove three (3) additional 1/4" hex screws that secure the convect motor assembly. Pull convect motor assembly into the oven cavity, disconnecting the electrical quick-connect.

Reattach by returning to original position using reverse procedures.

Resistance check -

WH to BR: approx. 63 Ohms

WH to BU: approx. 48 Ohms

NOTE: To remove the cover only, remove the screws at the 12:00, 4:00, and 8:00 o'clock positions.

Front Closure Replacement

1. Follow removal steps for the following components: control panel, oven door, oven-hinge pocket, and oven liner.
2. Remove side trim by grasping rear of trim with both hands. Pull forward and roll front of trim off of trim retainer clips.
3. Remove screws that mount into upper flange and the screws from lower leg support.
4. Install new part and reverse the steps for reassembly.

Regulator (SVD only)

The regulator is accessible from the front.

To remove regulator:

1. **Turn off gas supply and disconnect power.**

2. Remove the base door.
3. The regulator is located low on the right bottom rail. Disconnect the supply tube (front). Disconnect the gas source (rear).
4. Remove three (3) screws from the outside of the right side panel. Remove two (2) screws from the inside attaching the bracket to the bottom rail. Remove the bracket with the regulator attached.
5. Remove four (4) screws (two (2) on each side) that assemble the bracket. Remove two (2) screws mounting the regulator to the bracket.
6. Reassemble bracket with replacement regulator.
7. Remount regulator/bracket to the unit and connect supply tube (torque to 70 in./lbs./min.).
8. Connect gas source. **Make sure to use a high quality pipe joint compound acceptable for L. P. and natural gas, or apply an approved Teflon tape to all thread connections.**
9. Make sure replacement regulator is "setup" for proper fuel, L. P. or natural gas.
10. **Check for gas leaks at all connections.**
11. Reinstall base door.

Gas Supply

The dual fuel range is factory equipped for natural gas. Orifices are provided for LP conversion. If the Natural gas orifices are lost, burner tubes must be ordered to reinstall.

Required Outlet Pressures

Setting	Inlet (W.C In)	Flow (S.C.F/Hr.)	Outlet (W.C. In.)
Natural	7.0	40.0	5.0 ^{+0.4/-0.0}
L. P.	13.0	16.0	10.0 ^{+/-0.5}

Service Drawer (Select Models)

Pull service drawer out to the first stop position. Lift up front of drawer and pull to the second stop position. Grasp sides and lift up and out to remove drawer.

To Replace: Fit ends of drawer guides onto rails. Lift up drawer front and gently push into first stop position. Lift up drawer again and continue to slide drawer to the closed position.

NOTE: The wiring diagram for the some models is located at the back of the service drawer or on the back side of the access panel. If the diagram is removed, please ensure it is replaced for future use.

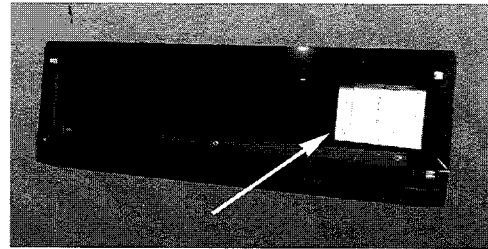

Access Panel

The access panel is easily opened or removed. To open panel, grasp upper corners and pull forward and down. To close panel, lift up and insert prongs into catches in the range.



Oven Racks

To remove, pull forward to the "stop" position; lift up on the front of the rack and pull out.

One flat rack and one offset rack are packaged with the oven. **NOTE: Some models will have an additional flat rack.**

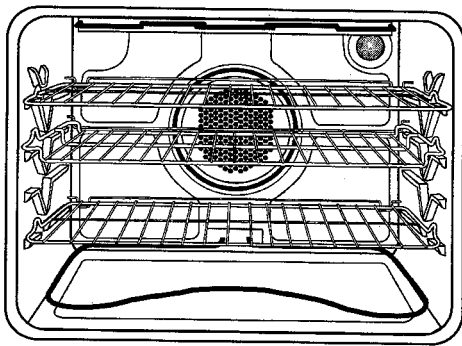

Flat Rack
Offset Rack
Flat Rack

Blower-Motor

The Blower-Motor Assembly can be removed for servicing with the range in place thru the lower access door. If the ducting installation is a type with the Blower-Motor Assembly connected directly thru on an outside wall or the floor, first remove the duct tape around the blower exhaust/duct joint. Then remove assembly mounting screws and disconnect electrical supply cord.

If the ducting installation utilizes a length of flex duct, first remove either duct clamp at the lower plenum or the blower exhaust. Then remove assembly mounting screws and disconnect electrical supply cord.

Grease Containers

The containers are located behind the bottom access panel, underneath the range. There is one container for the left side and one for the right side (some models).

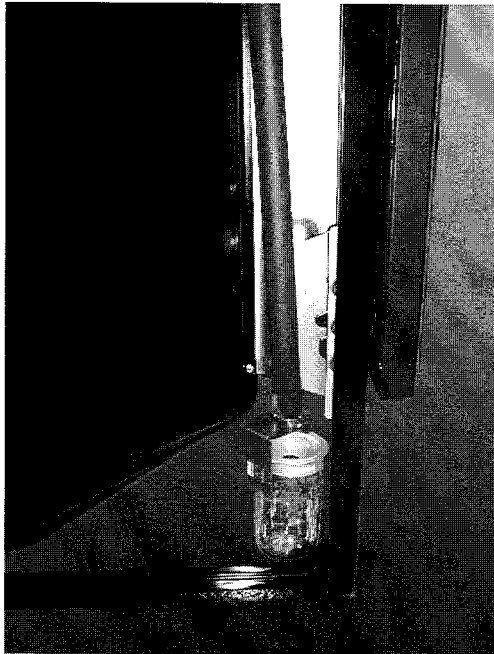

To remove, simply grasp the handle, and pull from the bracket holding the container.



Meat Probe (Selected Models)

The meat probe senses the internal temperature of products during a baking function. The probe is an NTC (negative temperature coefficient) which means the resistance value decreases as the temperature increases.

To Access:

1. Pull unit out from cabinet.
2. Remove nut securing meat probe receptacle in oven cavity.
3. Replace meat probe receptacle.

MEAT PROBE	
Type: NTC Thermistor	Calibration: 9938 ohms (150°F)
PROBE RESISTANCE VS. TEMP. TABLE	
Degrees F.	Resistance
122	18963 ohms
150	9938 ohms
156.2	8846 ohms
165.2	7456 ohms
210.1	3886 ohms

Oven Sensor

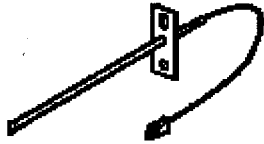

The oven sensor is a device to monitor internal oven temperature. The sensor has a PTC, positive temperature coefficient, or a resistance value that increases with temperature. This allows the electronic control to maintain a temperature setting through means of resistance matching with the control-selected temperature. Example: The oven control is set at 350° F, the oven sensor resistance at room temperature is approximately 1060 ohms. As the oven heats, the resistance of the sensor increases. The resistance of the sensor at 350°F is approximately 1654 ohms. The electronic control monitors the resistance value of the sensor and cycles the oven heating elements off. As the temperature in the oven decreases, the resistance of the sensor decreases. At a predetermined temperature setting, the electronic control will initiate another heating cycle in the oven elements. **See oven sensor chart for resistance values.**

Resistance check - approximate 1.1K Ohms at room temperature.

To Access: Remove two (2), 1/4" hex screws, pull oven sensor into oven cavity to gain access to the electrical quick connector.

To reassemble, the connector for the sensor needs to be pushed through both the oven cavity and the back of the range. If the connector is trapped between the liner and the back of the range, it could damage the connector. Use a screw driver or probe to guide the sensor connector through the insulation to ensure the connector does not contact the oven cavity.

Return to the original position, reattaching with the 1/4" hex screws.

OVEN SENSOR	
Sensor Type: RTD 1000 ohm platinum	Calibration: 1654 ohms (350°F)
OVEN SENSOR RESISTANCE VS. TEMP. TABLE	
Degrees F.	Resistance
100	1143 ohms
200	1350 ohms
300	1553 ohms
350	1654 ohms
400	1753 ohms
500	1949 ohms
600	2142 ohms
700	2331 ohms
800	2516 ohms
900	2697 ohms
1000	2874 ohms

Back Panel Access

Remove four (4), 1/4" hex screws from wire cover/back panel for access to the following components: Cooling fan, oven control circuit board, down draft circuit board, main wiring terminal, light wiring, line cord terminal block, ignition module (SVD models).

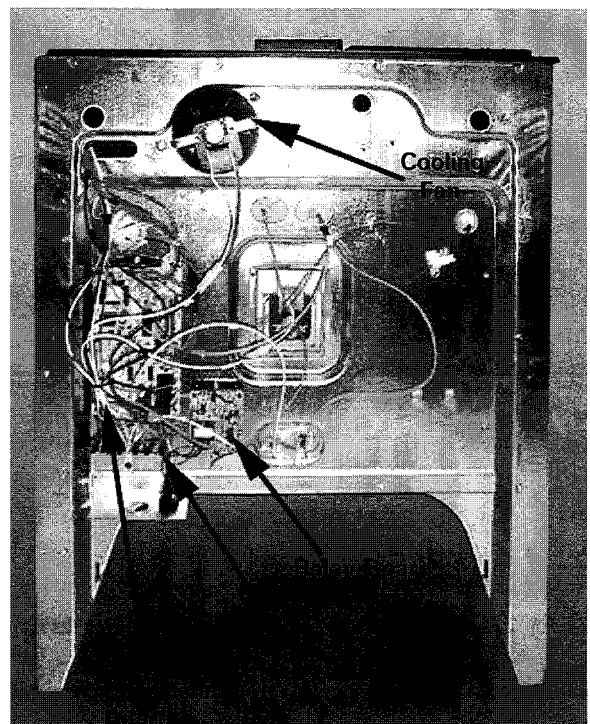

Cooling Fan Access

To access the cooling fan, remove two (2), 1/4" hex screws from the bracket which the fan is mounted on. Tilt motor and bracket to allow it to pass through main back panel.

Cooling fan motor resistance check - approximately 46 ohms.

Relay Board (Downdraft)

Remove the relay board by removing one (1), 1/4" hex head screw. Remove the electrical connections and lift the board up and out to re-move it from the two locking tabs. This relay board supplies power to the downdraft motor.

Power Relay Board (Bake/Broil Convect)

Remove the relay board by removing one (1), 1/4" hex head screw. Remove the electrical connections and lift the board up and out to remove it from the two locking tabs. This relay board contains the intelligence in the electronic control system and controls all oven functions, clock, timer, and various other consumer programmable inputs. The PRB has a relay mounted to it for each function it provides.

NOTE: The SVE87600 has three (3) circuit boards behind the rear cover. They include all of the boards listed above, plus the cook-top relay board.

Spark Module (Select Models)

Located on the back of the unit. Remove two (2), screws securing module to main back. Disconnect wiring and replace.

Fan Relay Switch (SVD Models Only)

The relay is located on the back of the unit.

To service this component:

1. Turn off gas supply and disconnect power.

2. Remove back cover.

3. Remove screws that mount the relay.

4. When reinstalling the relay, it is necessary to attach the wires before mounting the relay to the unit. The terminal designation is difficult to read after it is mounted.

5. Reverse procedure for reassembly.

6. Relocate the unit and **check for gas leaks at the regulator connection.**

Terminal Block

Remove back access panel. The terminal block is attached with two (2), 1/4" hex head screws and one (1), 1/4" hex head screw that is used to attach the grounding strap.

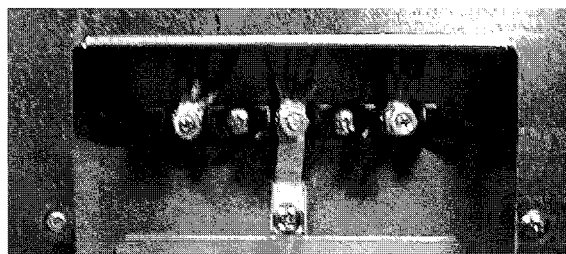

Control Panel Access

The following are instructions to access, repair and replace control panel components of the slide-in range.

1. To remove the control panel, open the oven door as wide as possible. Remove four (4), 1/4" hex-head screws from the bottom of the control panel. Grasp the control panel

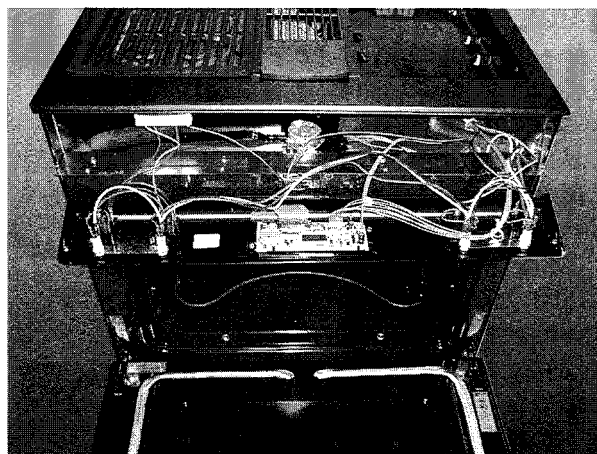

by placing hands on the right and left sides of the panel, pull out and down to disengage.

2. Locate the slot on the bottom of the control panel. Then, place the control panel on the tab.

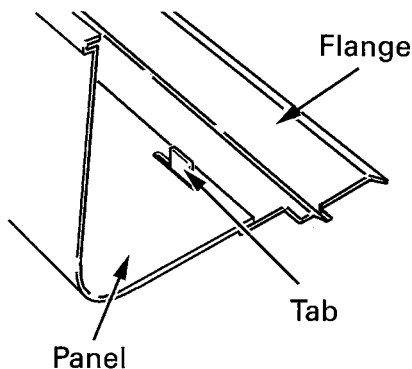

SC007TIF

Infinite Switch (Select Models)

Infinite switches may be accessed by removing the control panel. Pull the switch knobs straight off the control panel. Each switch may be removed by using a T-15 Torx head wrench. Remove two (2) torx head screws and disconnect the wires. Replace switch and reattach.

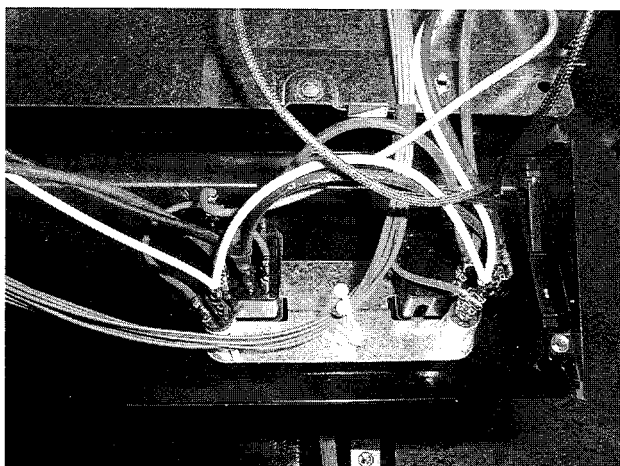

Selector/Thermostat (Select Models)

Selector/Thermostat switches may be accessed by removing the control panel. Pull the switch knobs straight off the control panel. Remove two (2) screws and disconnect the wires. Replace switch and reattach.

Burner Indicator Lights

The burner indicator lights are attached to the infinite switch bracket. They may be removed by squeezing the two tabs on the indicator light body and pulling. Transfer wiring and replace.

Electronic Clock

Used on base models, it is a self-contained membrane, electronic control, and relay package.

The electronic key pad oven control may be removed by removing two 1/4" hex head screws securing the clock to the control panel. Transfer wire connections and reattach.

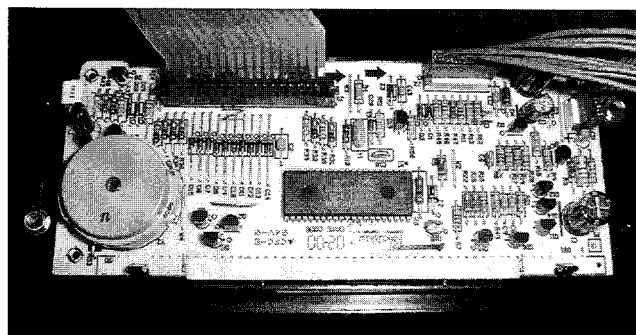

Electronic Surface Control

The Electronic Surface Control, or ESC, is used as the means to control the surface unit's heating and cycling functions through electronic circuitry and relay operation. It is a three part-system consisting of the following components:

- **Membrane Keypad**, which instructs the system to perform the selected function.
- **Display Board**, which illuminates the selected cycle and interprets the selected function from the membrane keypad.
- **Relay Board**, which has the intelligence for the system contained in a microprocessor, and controls the surface elements cycle rates.

Access by removing the control panel.

Main Top Components

Components that are accessible by removing the main top are: Clocks, selector switch, thermostat, solenoid, fan/light switch, high limit switch, grill pans, receptacles, radiant elements, drain tubes, ignitors, burner valves, manifold supply tube, and upper plenum. The procedure will vary depending on the service to be performed.

Main Top Removal

1. Turn off gas supply and disconnect power.

2. Remove range from its installed position. To remove the main top, remove screws from bottom edge of control panel. Pull the control panel forward and down for easy access and removal of the maintop.

3. Remove eight (8), (1/4") hex screws that secure the top. There are two (2) hex screws on each side and four on the back.

Remove the air grill, filter, grill grates, aeration pan and burners (if equipped).

Remove the screws from the plenum area at the front of the opening.

4. Electric models will require the receptacles to be removed, dual fuel models will require the burner tube nuts to be removed. Loosen nuts at manifold and rotate burner tubes to allow removal of top.

5. To remove the grill pans, the four (4) screws that mount each grill pan to the main top must be removed. Disconnect the spark ignitor from the bottom of the pan(s).

6. Remove plug from drain by using an allen wrench.

7. If access to the high limit is required, the receptacles may be left installed.

8. To reassemble the main top, reverse the procedure for disassembly.

9. Check for gas leaks at all connections.

Door Lock Assembly

With the main top removed, access to the door lock assembly is now possible. In some cases, access through the control panel is possible.

1. Remove two (2) phillips head screws from oven front cavity. Remove two (2), 1/4" hex head from mounting bracket securing lock assembly to cavity. Slide the lock assembly to the right to disengage from front frame. This will allow for easy access of switch replacement.

Remove (4) Screws

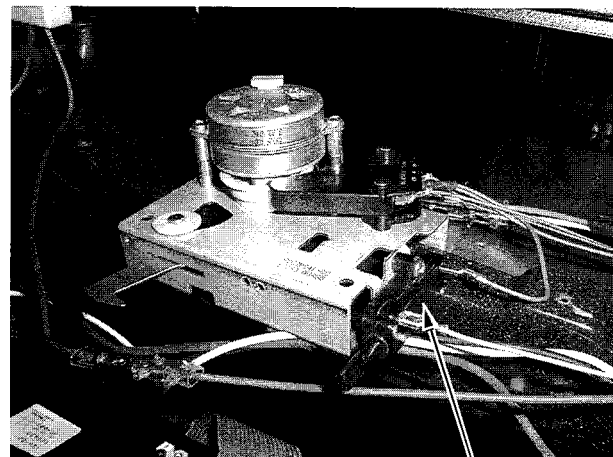
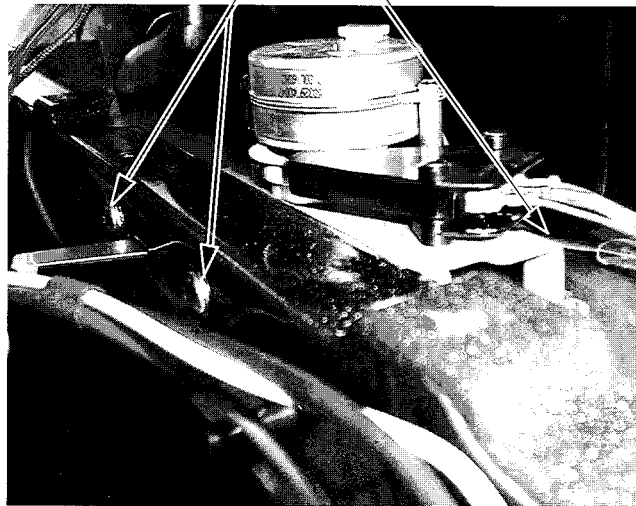

Remove Switch

2. Remove the door light switch from the lock mechanism by removing two (2) screws.

3. Replace lock mechanism by reversing the disassembly process.

Door Lock Mechanism (SVD8310S)

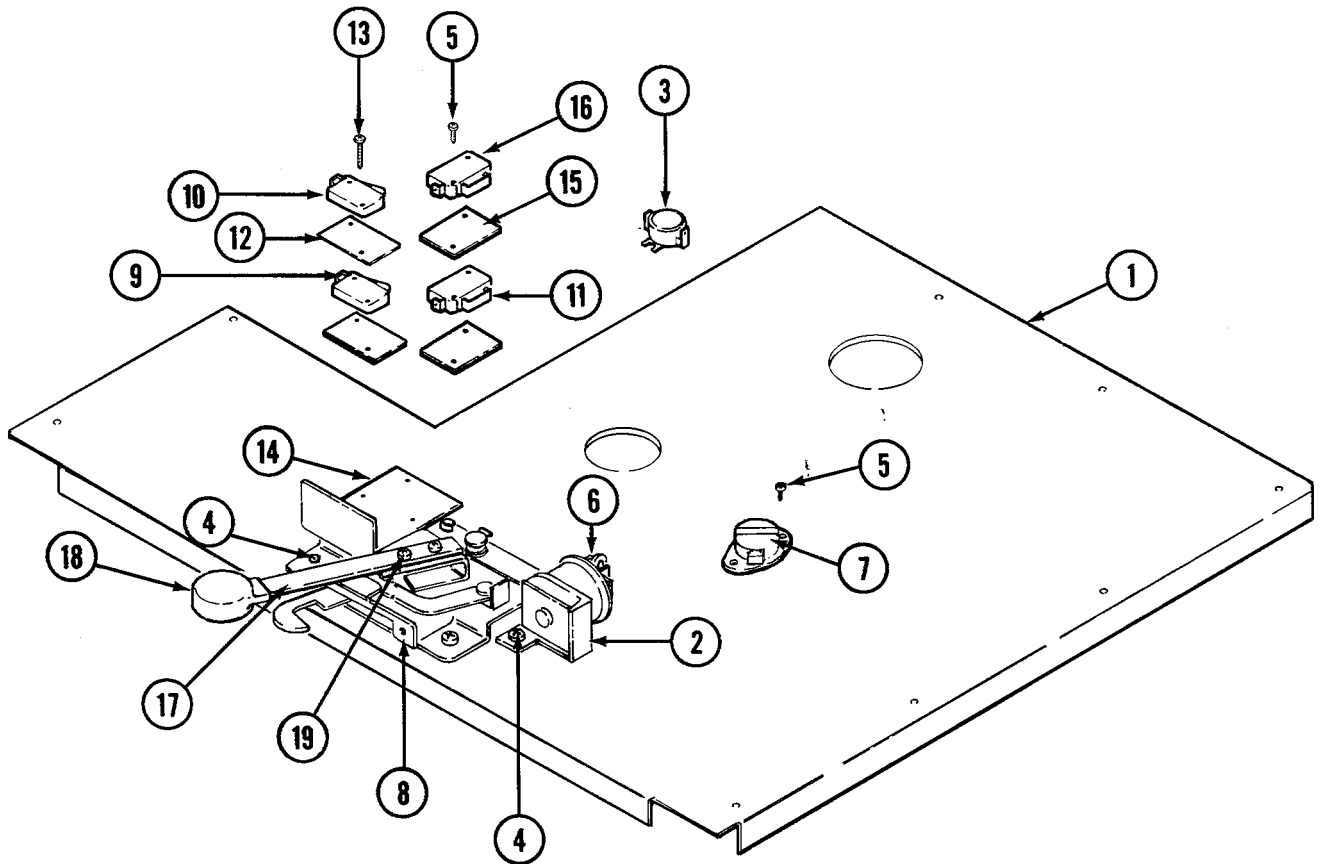

Internal Controls for SVD8310S

1. Panel, Top
2. Solenoid
3. Switch, Hi-Limit
4. Screw, Solenoid
5. Screw, Fan Limit (NA)
6. Pin, Cotter
7. Limit, Fan (NA)
8. Latch, Door
9. Switch, Rear Bottom
10. Switch Door
11. Switch Solenoid
12. Insulator
13. Screw, Insulator
14. Shield, Switch
15. Insulator, Switch
16. Switch, Latch

17. Lever, Latch (Blk)
18. Lever, Knob (Blk)
19. Screw, Latch Lever

Surface Burner Module

Before installing or removing grill/burner components, be certain control knobs are in the **OFF** position.

To Remove Burner Module:

1. Remove the aeration tray by lifting up the front end on the right side (back end on the left side) until the top clears the opening of the rangetop by about 5 inches.

2. Hold aeration tray by the sides and slide away to remove the prong from the opening and clear the surface burners.
3. Lift up on the sides of the surface burner assembly bracket about 2 inches. Slide away from the orifices.

To Install Burner Module:

1. Position the burner assembly with the mixer tube openings toward the orifices. Slide the burner assembly toward the orifices until opening for ignitor is over the ignitor. Lower into place until side openings are resting on the burner supports and ignitor is centered between the two flash tubes.
2. Install the aeration tray by inserting the prong at the end of the pan into opening in the end of the burner basin. Lower the opposite end into the range top.

To Install Grill Module:

1. Position the grillburner with the mixer tube openings toward the orifices. Slide the burner toward the orifices until the ignitor is in between front and rear grill sections. Lower into place until side openings are resting on the burner support pins.

High Limit Switch

Some units may be equipped with a high limit switch. The switch is a normally closed single pole, single throw. The switch can be accessed by the removal of the main top. Remove the grill pans, the four (4) screws that mount each grill pan to the main top must be removed. Remove two (2), 1/4" hex screws to replace witch.

Open Temp 250°F +/-8°F
 Close Temp 170°F +/-9°F
 Rated 25 Amp @ 240VAC

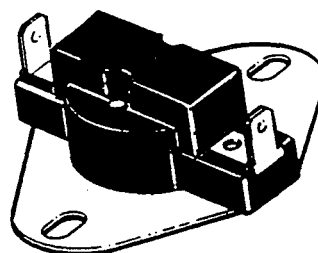

Spark Ignitor/Wires

Spark ignitor/wires replacement:

1. Turn gas supply off and disconnect power.
2. Remove top.
3. Disconnect the wires at the switch es-cutcheon and from the pan switch mounted on the left grill pan.
4. Disconnect the two wires from the spark module located on the back of the unit.
5. If replacing the ignitors, disconnect ignitor wires from spark module and remove nut and washer. Disengage ignitor from the grill pan and pull wires through hole in the grill pan.
6. Reverse disassembly procedure, making sure the ignitor wires are pulled tight through the holes in the unit back and held down by clips.

NOTE: The holes at the top of the ignitor must face the front and back of the unit to provide proper ignition.

7. Check for gas leaks at all connections.

Burner Tubes/Orifices

To replace burner tube(s):

1. **Turn off gas supply and disconnect power.**
2. Lower control panel.
3. Disconnect burner tube from valve.
4. Disconnect burner tube from grill pan.
5. When installing the new tube, first position hood through hole in grill pan. Finger tighten nut to valve making sure not to cross thread.
6. Tighten tube to valve* and grill pan.
7. **Check for gas leaks at all connections.**
8. Reassemble control panel to the unit.

NOTE: *Burner tube nut to valve torque 45 to 55 in./lbs. min.

Supply Tube

To replace the supply tube:

1. **Turn off gas supply and disconnect power.**
2. Lower control panel.
3. Remove the top assembly.
4. The supply tube is now accessible and can be disconnected from the manifold.
5. Disconnect the supply tube from the regulator. The regulator is located behind the base door at the right side of the unit.
6. The supply tube may now be removed through the top of the unit.
7. Reverse procedure for reassembly.

Be sure to torque the nut at the manifold to 60 in./lbs. min. Torque the nut at the regulator to 70 in./lbs. min.

8. **Check for gas leaks at all connections.**

Manifold/Valves/Stem Switches

To replace these components:

1. **Turn off gas supply and disconnect power.**
2. Lower control panel.
3. Loosen the burner tubes at the valves. Do not remove burner tube nuts from the valves unless tubes or valves are to be replaced.
4. Remove nuts and washers attaching burner tubes to the grill pans.
5. Remove stem switches from valve stems. Leave wires connected to switches unless the switches are to be replaced.
6. Disconnect the supply tube from the regulator* (lower right side, behind base door).
7. Remove the hex head screws from the side panels that hold the manifold in place.
8. Remove the wire ties holding wire harness to the manifold. Disconnect the supply tube* and remove the manifold.
9. Remove the valve(s) from the manifold and replace or install them on the replacement manifold. Make sure the blue tip valves are installed at the right side nearest the supply tube connection, and the black tip valves are installed at the left side.

NOTE: When replacing valves, be sure to use double gaskets at the bottom connection. This will ensure a good seal with the old manifold.

10. Reinstall the screws securing the manifold to the side panels. Make sure that the screws are in the high side of both slots on each side when fastening. This will help align the valve stems in relation to the control panel.

11. Be sure to replace the wire ties on the manifold, otherwise wires may become entangled in door lock mechanism.

12. Check for gas leaks at all connections.

13. Reverse procedure for reassembly.

NOTE: *Supply tube nut to manifold torque: 60 in./lbs. min. Burner tubes nut to valve torque: 45-55 in./lbs. min. Supply tube nut to regulator torque: 70 in./lbs. min.

Pan Switch

To remove the pan switch:

1. **Turn off gas supply and disconnect power.**
2. Lower control panel.
3. The switch is located on the front of the left grill pan. Remove wires.
4. Remove the nuts that mount the switch to the grill pan and replace.
5. Be sure the strike plate on the switch arm is aligned properly. The projection pin on the aeration pan should fully depress the switch as it sits flat on the unit top. If adjustment is needed, do so by carefully bending the switch arm with needle nose pliers.
6. Reverse procedure for reassembly.

Cycle Switch

To remove the cycle switch:

1. **Turn off gas supply and disconnect power.**
2. Remove top assembly.
3. Cycle switch is located on the upper right side panel.
4. Replace by removing mounting screws and wires.
5. Reassemble in reverse order.
6. **Check for gas leaks at all connections.**

Ceramic Radiant Elements

Select models are equipped with ceramic radiant elements. Cooking areas are identified by patterns in the ceramic surface. The element consists of elements coil(s) contained in the element housing. Power to the element (240 volts) is provided and controlled by an electronic control. There are three Ultra Quick-Start™ radiant elements and one Ultra Quick-Twin™ dual radiant element. The large elements are rated 2200 watts and the small elements are rated 1200 watts @ 240 volts. The dual element is rated 2400/1000 watts at 240 volts.

To replace elements:

1. **Disconnect the appliance from power source before servicing.**
2. Remove glass top assembly by removing eight (8), (1/4") hex screws that secure the top. There are two hex screws on each side and four on the back.
3. Remove tinnerman clips securing element on element supports.
4. Disconnect wiring and replace.
5. Reverse procedure to reinstall.

Ventilation System

The oven light automatically comes on whenever the oven door is opened. When the door is closed, the oven light may be turned on by pushing the three position switch toward the light symbol. To turn oven light off, push switch to the middle position. Light cannot be turned on during the self-cleaning process. If the switch is pushed toward the fan symbol, the ventilation system will be turned on.

The ventilation system will operate automatically when the grill burner is in use.

Section 3. General Component Testing

Electrical Components

Infinite Switch

The *infinite switch* is the mechanical device used to control voltage supply to a heating element. When set to the "Hi" position, the contacts from L1 and L2 are mechanically fixed to allow for 100% operation. In any position other than "Hi," the cycle rate is determined by the amount of spring tension exerted on the cycling contact. Wrapped around the contact arm is a heater that will

create a bi-metal effect on the arm, causing the material to bend, thus opening the contact. The closer the switch is set to the "Low" position, the less spring tension is exerted on the contact. The infinite switch used in these products is a voltage-sensing type. This means the heater wire that is wrapped around the cycling contact will be activated in any position other than "Off." This will cycle the contacts in the switch regardless of the presence of a heating load such as a surface element. See detail of switch on chart below.

Cycle Rate For 703650 Infinite Switch		
Setting	% On	Range
Hi	100	100
10	65	62-70
9	50	48-53
8	45	44-47
7	42	39-43
6	35	33-37
5	31	28-32
4	22	21-24
3	19	16-20
2	11	9-13
Lo	6	4-8
Off	0	0

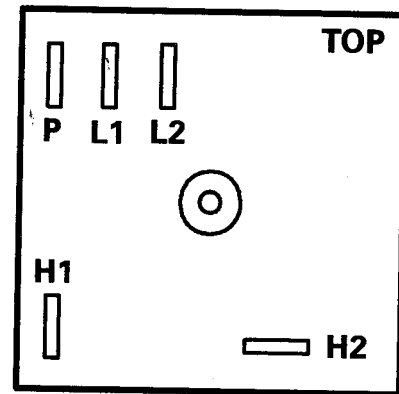

SC009TIF

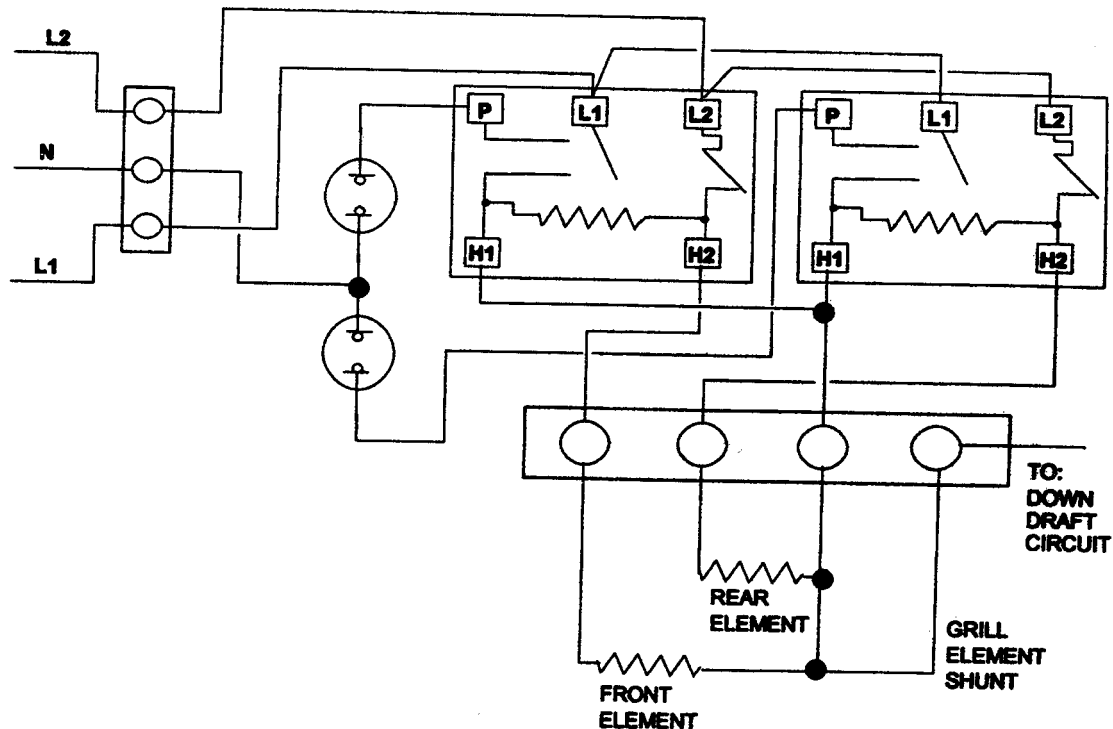

NOTE: Resistance reading from H1 to H2 is 15.5 K +/- 10%

Dual Element Infinite Switch

Dual Element: Consists of an inner coil and outer coil. The inner coil can be activated independently; however, when the outer coil is selected, the entire coil is supplied with voltage from the switch.

Dual Element Switch: Controls either an inner coil (high through low) or both the inner and outer coils of the element (high through low). *See chart for cycle rates and contact circuitry.*

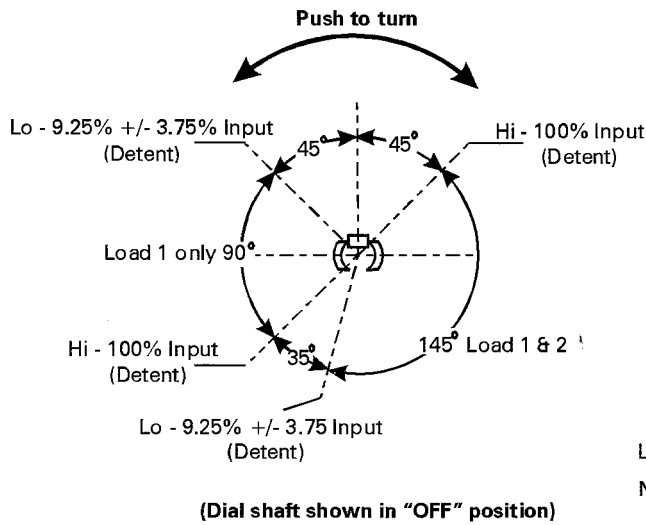

Typical Output Graph

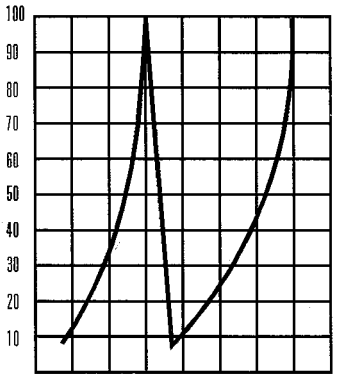

Degrees rotation of dial shaft in the counterclockwise direction (Ref only)

Wiring Diagram

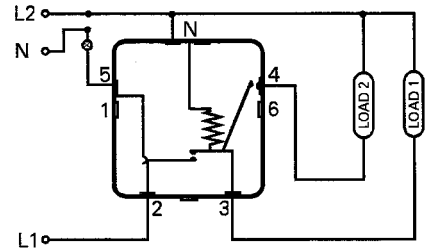

Switching Sequence

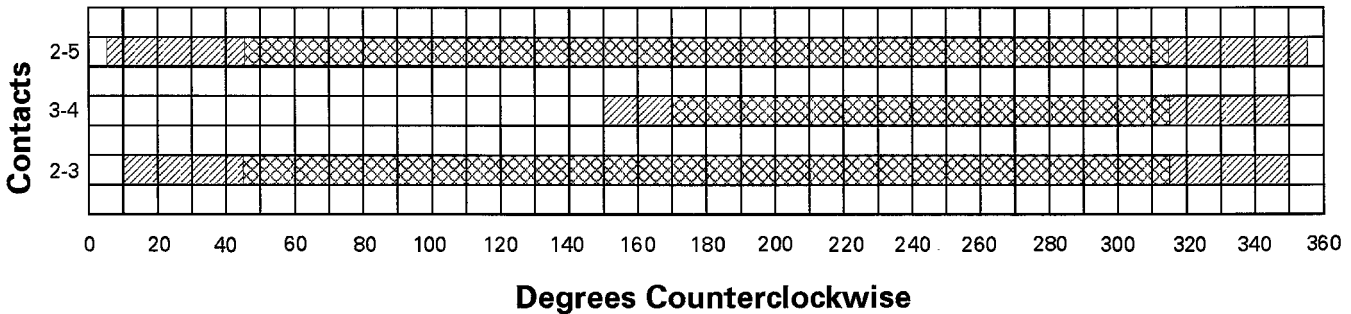
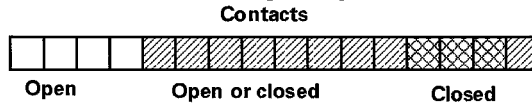

Contacts 2-5 must close before contacts 2-3 in the counterclockwise direction.

Contacts 2-5 must close before contacts 3-4 & contacts 2-3 in the clockwise direction.

SC008T1F

Electronic Surface Control

The Electronic Surface Control, or ESC, is used as the means to control surface element output rates. It is a three part-system consisting of the following components:

- **Membrane Keypad**, which instructs the system to perform the selected function.
- **Display Board**, which illuminates the selected cycle and interprets the selected function from the membrane keypad.
- **Relay Board**, which has the intelligence for the system contained in a microprocessor, and controls the surface elements cycle rates.

The membrane keypad is the interface to the control system. The desired selection is conveyed to the control by pressing the membrane for the desired function. This closes the switch contained in the membrane panel. This closing of the chosen contact is interpreted by the display board microprocessor. The display board instructs the relay board to activate the chosen function. The relay board closes the contacts of the relays, sends voltage to the selected element and the heating process of the element begins.

Operation Specifications

NOTE: The ESC will beep once for each keypad entry.

The **ON/OFF** key is the master switch for element operation. The ESC will not function unless there is a two-step input operation. When the **ON/OFF** key is pressed, the display will show two dashes. If another key is not pressed within 15 seconds, the display will go blank and terminate the cycle.

To begin a heating cycle, press the **ON/OFF** key, followed by the desired heat level, either **UP**, **DOWN**, or **MED** key. The **UP** and **DOWN** key is a slew-type and the cycle rate displayed can be increased or decreased by holding the appropriate key down. The slew keys will

stop at either the highest or lowest allowable setting.

The **DUAL** key is used to choose between the inner coil of the dual element or both the inner and outer coils. When the **D** is displayed, it means the element is set for both inner and outer coil operation.

The **UP** key is a burner command key. When it is pressed immediately after the **ON/OFF** key is selected, the element will be selected to a high setting or 100% operation. If the **UP** key is held for longer than two seconds after the display has reached **HI**, the control will beep twice indicating that the highest setting has been reached. The dual beep repeats every second until the **UP** key is released. The slew rate for change of the settings is 0.25 seconds when the key is held down, *see Table 1.*

ELECTRONIC SURFACE CONTROL			
Time Chart-Display vs. Element			
Setting	On Time	Off Time	%On
LO	1.5	58.5	2.5
1	3.5	56.5	5.8
2	6.5	53.5	10.8
3	11.5	48.5	19.2
4	15.0	45.0	25.0
(MED) 5	18.5	41.5	30.8
6	22.0	38.0	37.0
7	27.5	32.5	45.8
8	33.5	26.5	55.8
9	39.5	20.5	65.8
10	45.0	15.0	75.0
HI	60.0	0	100

Table 1

The **DOWN** key is a burner command key. When it is pressed immediately after the **ON/OFF** key is selected, the element will be selected to a **LO** setting or 2.5% operation. If the **DOWN** key is held for longer than two seconds after the display has reached **LO**,

the control will beep twice indicating that the lowest setting has been reached. The dual beep repeats every second until the DOWN key is released. The slow rate for change of the settings is 0.25 seconds when the key is held down, *see Table 1*.

The MED key is a burner command key. When it is pressed immediately after the ON/OFF key is selected, the element is selected to a setting of 5. If the MED key is held for longer than two seconds after the display has reached 5, the control will beep twice indicating that the medium setting has been reached. The dual beep repeats every second until the MED key is released, *see Table 1*

The DUAL key activates an asterisk (*) in the display when both the inner and outer elements are selected. If the dual burner is activated for inner element operation only the (*) will not be displayed. The DUAL command can be selected anytime after the

ON/OFF key has been selected. The element is energized for inner element operation as a default unless the DUAL key is selected.

The **CHILD LOCKOUT** command can be selected to prevent operation of the heating elements. The lockout command will be recognized even during element operation if the proper keypads are pressed and held down. To activate the lockout feature, press and hold both the UP and MED keys for 5 seconds. After 5 seconds, OFF will be displayed for 15 seconds. **To unlock** the control, press and hold the UP and MED keys for 5 seconds. OFF will be displayed for the 5 seconds while holding the UP and MED keys down. Then display will go to blank, indicating the lockout has been canceled.

The following tests are available during the test mode:

Dual Keyboard Only						
Keystroke	Display Status		Relay Response			
	*	8 8 8 8	K1/K5	K2/K6	K3/K7	K4/K8
UP/Down Key Test MED, right side	on	8 8 8 8 L	off off	off off	off off	off on
UP, right side DOWN, right side	off off	L E L	off off	off off	on off	on on
MED, left side UP, left side	off off	L L E	off off	off on	off off	on on
DUAL DOWN, left side	On	L E L	on on	on off	off off	on on

Table 1

Standard Keyboard Only						
Keystroke	Display Status		Relay Response			
	*	8 8 8 8	K1/K5	K2/K6	K3/K7	K4/K8
UP/Down Key Test MED, right side	on	8 8 8 8 L	off on	off off	off off	off on
UP, right side DOWN, right side	off off	L E	off off	off off	on off	on on
MED, left side UP, left side	off off	L L E	off off	off on	off off	on on
DOWN, left side	on	L	on	off	off	on

Fault Codes

There are four built-in fault codes to assist the technician in diagnosis of the control system. Any time the control senses an error in the system, the control will beep at a 1 second interval until the ON/OFF key is pressed.

F1: Indicates an element cycle relay is in the on position when the control has not been programmed for a heating cycle. Element operation will be terminated.

F2: Indicates an element cycle relay is in the off position when the control is in a selected heating mode. Element operation will be terminated.

F5: Indicates the vacuum fluorescent display circuit has shown an error. Element operation will be terminated.

F7: Indicates a shorted keyboard pad or keyboard connector. Element operation will be terminated.

Fault Code Trouble Shooting		
Fault Code	Likely Cause	2nd Probable Cause
F1	7 Wire Harness Shorted	Replace Power Board
F2	7 Wire Harness Shorted	Replace Power Board
F5	Replace Display Board	---
F7	Replace Keyboard	Replace Display Board

Bake Element

SVD8310S
 2400 Watt @ 240 VAC
 1800 Watt @ 208 VAC
 Cold Resistance 23.3 +/-5%

All others

2800 Watt @ 240 VAC
 2100 Watt @ 208 VAC
 Cold Resistance 19.97 +/-5%

Broil Element

SVD8310S
 3000 Watt @ 240 VAC
 2250 Watt @ 208 VAC
 Cold Resistance 18.6 +/-5%

All others

3600 Watt @ 240 VAC
 2700 Watt @ 208 VAC
 Cold Resistance 15.53 +/-5%

Control Voltages

Terminals	Voltages
L1 to N	120V
L1 to BAKE	240V
L1 to BROIL	240V

Element, Ceran Top (Large)

Electrical Ratings: 240 VAC, 2200 Watt
 Cold Resistance: 25.4 +/- 5%

Element, Ceran Top (Small)

Electrical Ratings: 240 VAC, 1200 Watt
 Cold Resistance: 46.6 +/- 5%

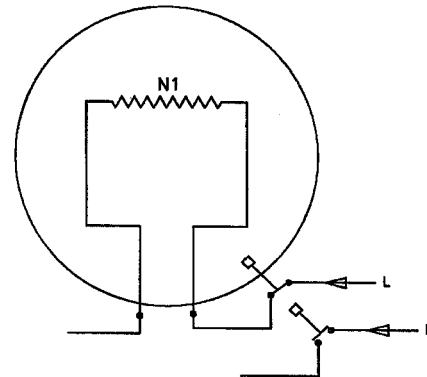

SERIES-7
 SCHEMATIC WIRING DIAGRAM
 VIEW ON TOP OF HEATER

Element, Ceran Top (Large-Dual)

Electrical Ratings: 240 VAC, 2400/1000 Watt
 Cold Resistance: 55.9 +/- 5% (Inner)
 Cold Resistance: 39.9 +/- 5% (Outer)

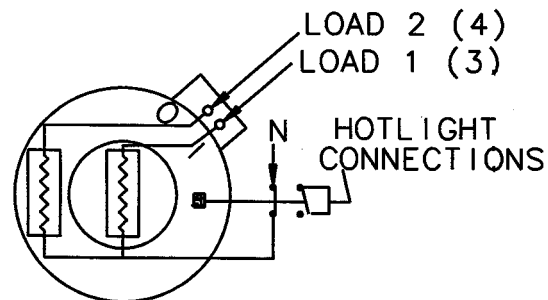

SERIES 7
 SCHEMATIC WIRING DIAGRAM
 VIEW OF BOTTOM OF HEATER

Surface Unit Switches (Some Models)

The infinite switch used in these type products is a voltage-sensing type. This means the heater wire that is wrapped around the cycling contact will be activated in any position other than "Off." This will cycle the contacts in the switch regardless of the presence of a heating load such as a surface element.

Electrical Ratings:	15 Amp @ 240 VAC
L1 = P	0.5 Amp @ 240 VAC
L1 = H1	15 Amp @ 240 VAC
L2 = H2	15 Amp @ 240 VAC

SURFACE UNIT SWITCHES

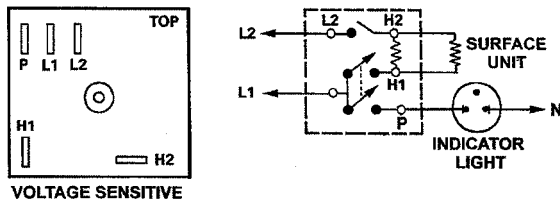

Sensor and Lock Circuits (SVD8310S)

Power should be disconnected and an ohm meter reading taken at the connector.

SENSOR AND LOCK CIRCUITS

Power should be disconnected and an ohm meter reading taken at the connector

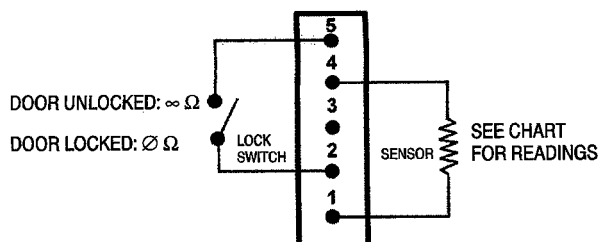

PINS 1 AND 4: OVEN SENSOR
PINS 2 AND 5: DOOR LOCK CIRCUIT

Cooling Motor (SVD8310S)

Electrical Ratings:

240 Volts 50-60 HZ
28 Amps at 230V 60 Hz
1675 RPM CCW at 230V 60 Hz.

Relay (SVD8310S)

120 VAC, 24MA Coil Max
Type: Triple Pole - Single Throw (3PST)
Coil: Resistance: 1700 Ohms \pm 15%

Solenoid (SVD8310S)

Voltage: 120 V 60 Hz.
Resistance: 155 Ohms

Relay D.L.B. (SVD48600PC)

Voltage: 240VAC
Coil Voltage: 9 V D.C.
Ratings: NC = 10A, NO = 20A.

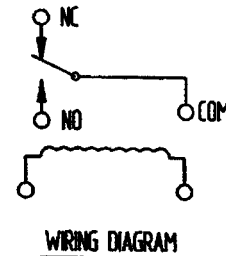

Mode of Oven Operation (SVD8310S)

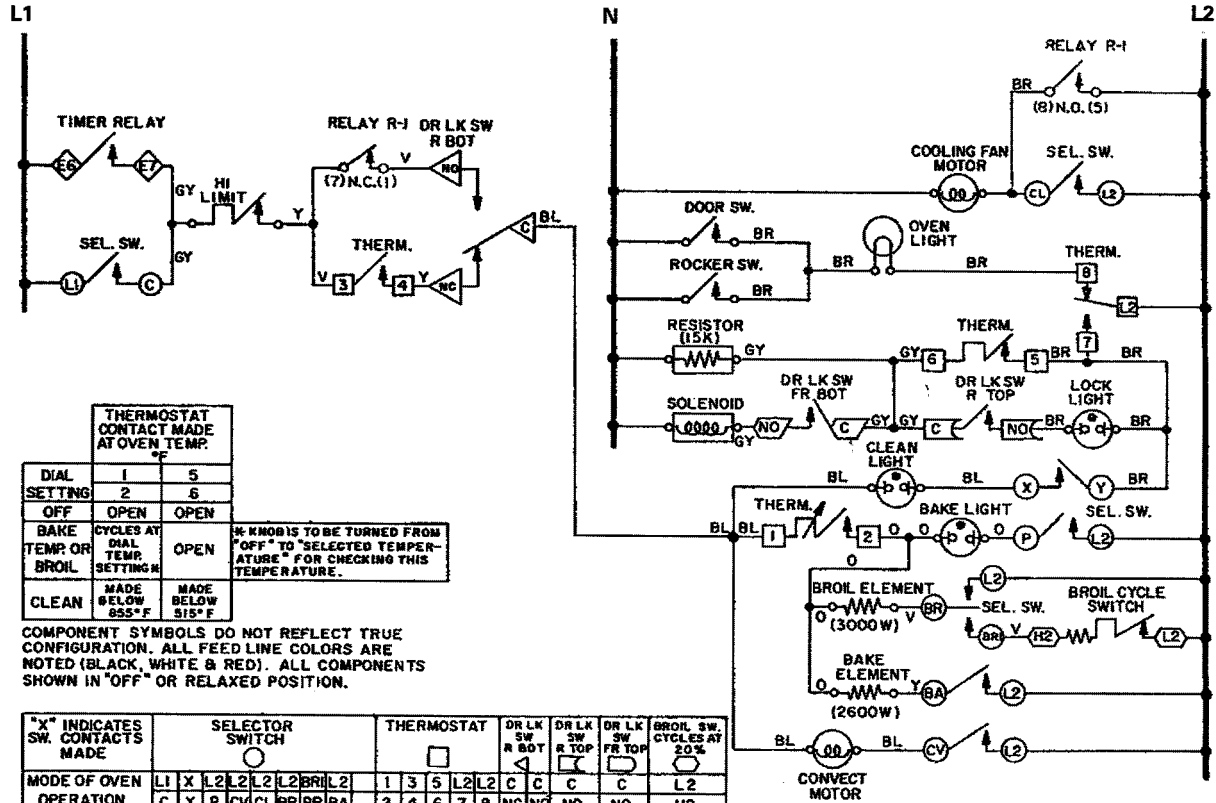

NOTE: CLEAN CYCLE WILL BE INTERRUPTED WHEN RELAY R-1 IS ENERGIZED.

The information in this section is intended for use by a Maytag authorized service technician. **The customer should be completely informed of any unsafe or improper condition that may effect the correct operation of the appliance.**

Mode of Oven Operation (Basic)

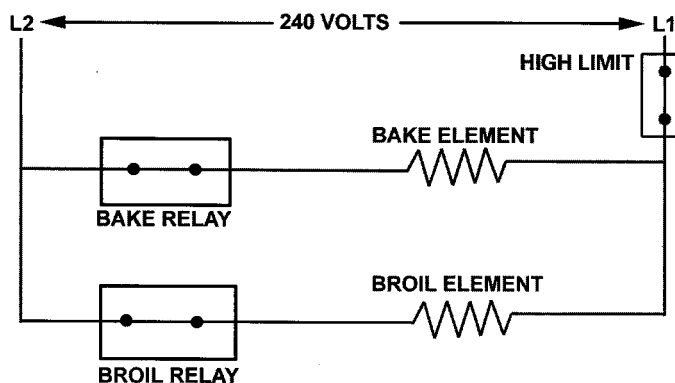

SC146TIF

MODES OF OPERATION	L1		L2							Lock door Switch with door shut	Cam Switch	
	N	DLB	Door lock	Cool	Broil	Bake	Cv Bake	Cv Rst	Ov Light		C Lock	C Unlock
OFF	X											
BAKE		X		On at 500° Off at 490°	Cycles	Cycles				Lock door Switch or pad	x	x
TIMED BAKE		X		On at 500° Off at 490°	Cycles	Cycles				Lock door Switch or pad	x	x
CONVECT BAKE		X		On at 500° Off at 490°	Cycles	Cycles	X Door Closed			Lock door Switch or pad	x	x
TIMED CONVECT BAKE		X		On at 500° Off at 490°	Cycles	Cycles	X Door Closed			Lock door Switch or pad	x	x
CONVECT ROAST		X		On at 500° Off at 490°	Cycles	Cycles		X Door Closed		Lock door Switch or pad	x	x
TIMED CONVECT ROAST		X		On at 500° Off at 490°	Cycles	Cycles		X Door Closed		Lock door Switch or pad	x	x
CLEAN		X	During lock & unlock	On with selection Off at 490°	Cycles	Cycles					x	x
BROIL		X		On with selection Off at 490°	X					Lock door Switch or pad	x	x

8104p510-60b

The information in this section is intended for use by a Maytag authorized service technician. ***The customer should be completely informed of any unsafe or improper condition that may effect the correct operation of the appliance.***

Gas Components

Air Shutter Adjustment

To adjust surface burner air shutters (select models):

Loosen fastening screw with a phillips screw driver and rotate air shutter to increase or decrease the size of the air opening. As the shutter is turned observe change in flame appearance. Adjustment is satisfactory when a clearly defined, even blue flame results at the HI flame setting. After adjustment, tighten screw.

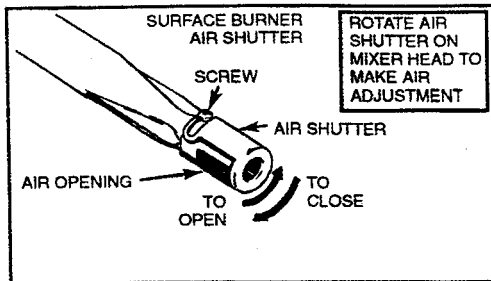

To adjust grill burner air shutters and surface burner air shutters (some models):

The left hand air shutter controls the rear half of the grill burner or the rear surface burner. The right hand shutter controls the front half of the grill burner or the front surface burner. Air shutters fit snugly on the burner, so a screwdriver blade may be required to make this adjustment.

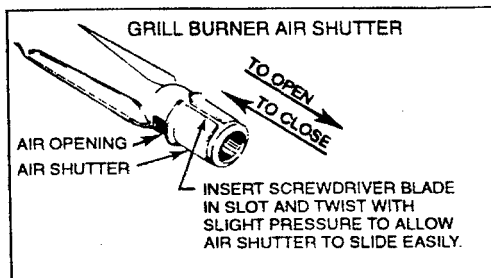

On any burner, closing the air shutter too far will cause the flame to become soft and yellow tipped. Opening the air shutter too

wide will cause the flame to blow away from the burner ports. Proper adjustment will produce a sharp, clearly defined, even blue flame.

To adjust the Lo setting:

1. Light burner and set control knob for low flame.
2. Remove control knob from valve stem.
Caution: Never use a metal blade to pry knob off.
3. Insert a slender, thin-blade screwdriver into the recess at center of valve stem and engage blade with slot in adjusting screw.
4. Turn center stem adjusting screw slightly to set flame size. **NOTE: Turn clockwise to reduce, or counterclockwise to increase flame size.**
5. Replace control knob when adjustment is completed.

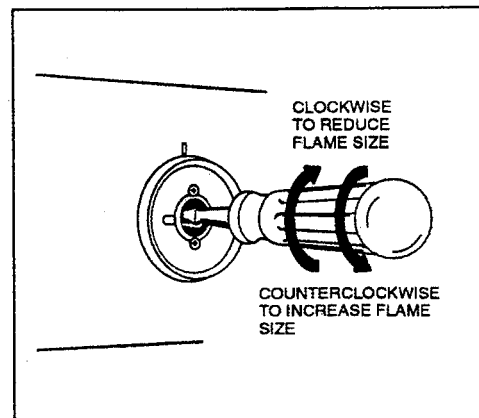

Proper adjustment will produce a stable, steady blue flame of minimum size. The final adjustment should be checked by turning knob from **Hi** to **Lo** several times without extinguishing the flame.

This adjustment, at the **Lo** setting, will automatically provide the proper flame size at the **Med.** setting.

Adjust Oven Temperature (SVD8310S)

The oven TEMP knob can be adjusted if the oven temperature is too low or too high and the length of time to cook all foods is too long or too short.

To adjust the TEMP knob:

Turn the oven TEMP knob to OFF. Remove the knob and turn it to the underneath side. Hold it so that the triangle is at the top. Loosen the two screws slightly. Hold the skirt in place, move the top screw by rotating the knob one notch, as noted by one click, in direction necessary. If notch indentation is not apparent, tighten screws until clicking is heard. There are five notches in each direction. One notch equals approximately 10°F. To replace knob, match flat part of knob opening with spring on the shaft, returning to the OFF position.

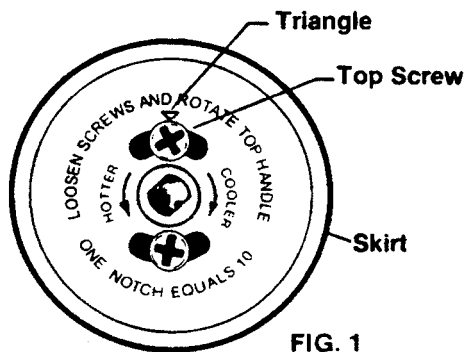

FIG. 1

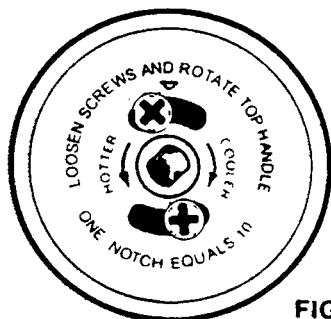

FIG. 2

Relay

Relay, Board 2 Speed Convection (Bake/Broil/Convection)

- Relay ratings Bake & Broil: 15 Amp, 240 VAC all other 5 Amp 240 VAC.
- Bake & Broil elements to be energized alternately.
- Oven light de-energized in clean
- Cooling fan "On" (Broil & Clean)
- Cooling fan "ON" temp = 510°F (Bake Modes)
- Cooling fan "OFF" temp = 500°F (All Modes)
- Door lock 548°F
- Bake Hi Limit 619°F
- Clean Hi Limit 952°F

Spark Module

Provides 14,000 to 16,000 VDC to ignitors. Do not check output.

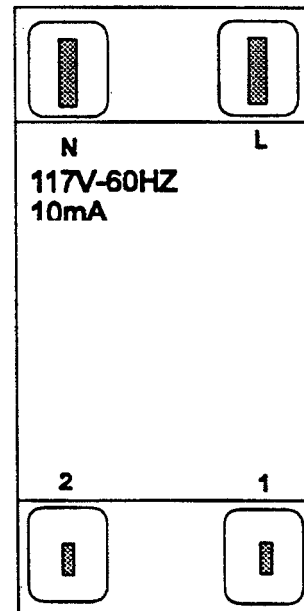

Check for 120 VAC between L and N. Ensure tight connections at 1, 2, and at ignitors. Ensure proper product grounding.

Cause & Effect

<u>Condition</u>	<u>Possible Cause</u>	<u>Correction</u>
No spark at ignitor(s)	1. Loose wire connection to spark ignitor. Turning on any valve will cause both ignitors to spark simultaneously. Both ignitor lead wires must be connected to spark module for either to work correctly.	Reconnect loose wires.
	2. Ignitor not grounded..	Tighten mounting nut to assure solid ground.
	3. Ignitor..	Replace ignitor(s).
	4. Spark Module..	Replace module.
Ignitor sparks- gas supply OK, will not light	1. Ignitor port in cap not in line with burner flash tube..	Align ignitor cap so port is in-line.
	2. Strong external drafts..	Locate cause; i.e. HVAC vent, etc. Advise customer on adjustment.
	3. Aeration pan, air grille, grates not in position..	Install parts for proper operation.
	4. Burner not seated into unit properly or flash tubes not aligned with ignitor port..	Seat or replace burner.
	5. Primary air shutter set too far open..	Adjust air shutter.
	6. Blocked burner ports..	Clear with straight pin or replace burner.
Ignitor fails through one valve, but works through another.	1. Stem ignition switch not securely seated..	Seat switch securely.
	2. Stem ignition switch (On left side switch assemblies, the lower switch is the ignition switch)..	Replace switch (on left side, replace entire switch assembly).
	3. Valve, no click heard (valve fails to rotate through full 175°, thereby failing to activate stem switch)..	Replace valve.
	4. Switch wiring..	Check connections: Yellow wire - Stem switch to spark module. Check splices and connections for proper continuity.

Condition	Possible Cause	Correction
Ignitor keeps sparking on setting other than "LITE"	1. Stem switch, internal contacts won't open..	Replace switch.
	2. Stem switch..	Check wiring against diagram.
	3. Valve..	Replace valve.
	4. Spark module..	Replace module.
Binding valve stems	1. Valve..	Replace valve.
	2. Stem switch or assembly..	Replace switch.
No "manual" fan operation	1. Rocker switch, contacts open..	Replace switch.
	2. Fan motor (windings open/shorted)..	Replace motor.
No "auto" fan operation (fan should run when left side valve(s) turned on and aeration pan removed)	1. Upper stem - switch on either L.H. assembly..	Replace switch assembly or seat switch securely.
	2. Reversed stem switch wires..	Check wiring. Brown wires should be on upper switches, yellow wires on lower.
	3. Relay..	Replace relay.
	4. N.C. pan switch or lever arm..	Bend lever arm so that projection pin on aeration pan makes contact or replace switch.
	5. Fan motor..	Check wiring. Replace motor.
Fan operates automatically when it shouldn't	1. Projection pin on aeration. Pan not depressing pan switch fully when installed on L.H. side..	Bend lever arm so that projection pin on aeration pan makes contact.
	2. N.C. fan switch..	Replace switch.
	3. Stem switch or relay..	Check wiring against diagram. Replace switch or relay.
Fan will not shut off	1. Rocker switch..	Replace switch.
	2. Relay or motor..	Check wiring against relay.
No flame - gas not reaching any burner	1. Line gas valve turned off, or air in manifold or supply line..	Turn supply valve on. Bleed gas line at regulator.
	2. Gas supply pressure to unit exceeding 14.0" W.C...	Reduce gas supply pressure (may require additional customer installed pressure regulator).
	3. Pressure regulator on unit or supply line..	Replace regulator.

Condition	Possible Cause	Correction
No flame - (continued)...	4. Pressure regulator on unit or supply line mounted backward (arrow on regulator body indicates direction of flow)..	Reverse regulator.
	5. Conversion cap in pressure regulator missing or unseated..	Check cap. Re-seat.
	6. Gas valve..	Replace entire assembly.
	7. Orifice fitting: Hood blocked or screwed tight against internal pin. Blockage within gas way..	Clear with straight pin. Back hood off internal pin at least 1 1/4 turns. Replace orifice fittings.
Flame blows away from burner ports - gas flows too high	1. Pressure regulator, pressure regulator cap is inverted (set for LP at 10" W.C. instead of natural at 5" W.C.)..	Replace regulator, invert conversion cap.
	2. Oversize outlet hole in orifice hood..	Replace entire orifice fitting.
	3. Wrong orifice hood installed.	Check color code on orifice hood (L.H. fittings are black, R.H. fittings are brass).
	4. Primary air shutter set too far open..	Adjust air shutter.
Flame too soft or lazy - gas flow too low	1. Gas supply pressure to unit below 6.0" W.C.	Supply pressure must be increased. Advise customer on correction required.
	2. Wrong orifice hood installed..	Check color code on orifice hood (L.H. side fittings are black, R.H. side fittings are brass).
	3. Orifice hood..	Clear with straight pin. Back hood off 1 1/4 turns.
	4. Primary air shutter set too far closed..	Adjust air shutter.
No gas or incorrect flow at "MED" or "LO" setting. NOTE: Correct adjustment at the "LO" setting automatically adjusts the "MED" setting.	1. Center stem adjustment..	Adjust center stem under knob to correct flame. Clockwise to reduce, counterclockwise to increase.
	2. Gas valve (flow won't adjust through center stem)..	Replace gas valve.
Unit not exhausting properly, or fan shuts off approximately 20 min. into operation	1. Ducting diameter too small, length of system too long, obstructions, too many elbows, or installed back to back.	Advise customer to have ducting corrected according to installation instructions.
	2. Fan motor..	Replace motor. Upon completion, if short cycling exists, problem is generally ducting, not motor.

<u>Condition</u>	<u>Possible Cause</u>	<u>Correction</u>
Nothing works	1. Fuse or circuit breaker tripped..	Replace/reset as necessary.
	2. Wiring to unit open..	Check for burnt or open wiring between service panel and unit receptacle.
Oven light stays on	1. Shorted panel or door switch..	Check continuity of switch.
	2. Door gasket holding door back..	If applicable, set unit up and run through self-clean cycle. Remove door and reshape gasket by hand. (Insure gasket has cooled before reshaping.)
Oven light will not come on	1. Loose or bad bulb	Tighten or replace. Note: Use brass base bulb to avoid fusing.
Oven not heating or improperly heating	1. Thermostat not closing..	Check thermostat for continuity while turning knob.
	2. Selector switch not closing..	Check selector switch for continuity.
	3. Open or shorted bake/broil element..	Check element(s) for continuity.
	4. Bake or broil relay or cycle switch not closing..	Check continuity of coil... If open, replace. Check for voltage at coil or cycling contacts during bake/broil cycle.
	5. Limiter in series with circuit may be open or cycling..	Check all limiters in circuit per wiring diagram. Check for proper cooling fan operation.
	6. Improper door gasket seal..	Check door gasket seal for tightness with pieces of paper. Check door hinges for weak springs or bent arms.
	7. Clock not set up properly for convection "time bake" or contacts open.	Review Use & Care book for proper procedure. Check contacts for continuity while advancing clock through cycle.
	8. Cooling fan inoperative..	Check for open fan limit contacts, binding fan blade, shortened motor.
	9. Supply voltage too low, too high. Generally a 5% (+/-) variance of unit rating is acceptable.	Have customer contact local utility company if extreme variances motor.

Condition	Possible Cause	Correction
Oven not heating ...(continued)	10. Element or wiring terminal..	Replace as necessary.
	11. Oven temperature incorrect..	Replace thermostat or adjust knob where applicable.
	12. Airflow restricted in oven due to size or type of bakeware.. <ul style="list-style-type: none"> • Catalyst blocked up with dirt or insulation • Door gasket closed down or open too far • Excessive steam build-up 	Inspect bakeware. Advise customer to review Use & Care manual. Check, remove obstruction if necessary. Normally a 2-3" gap should be acceptable.
Unit shuts off during baking	1. Controls area too hot...Cooling fan not running..	Check fan limit operation.
	2. High limit open or too low for rating..	Check and replace as necessary. NOTE: Limiter can be bypassed temporarily to test operation.
	3. Excessive insulation void near vent tube allowing heat to enter controls area..	Check area around vent tube. Close up with insulation if necessary.
	4. Thermostat..	With thermostat isolated, check cycling for operation while checking oven temperature.
Incomplete cleaning	1. Cycling not set up for long enough period to allow soil breakdown..	Advise customer to review Use & Care manual.
	2. Thermal high limit opening during cycle..	Check limit for operation. Replace if necessary.
	3. Cooling fan limit not operating. (Insufficient air flow)..	Check components for operation.
	4. Bake or broil cycles switch open..	Check/replace as necessary.
	5. Thermostat limit open during cycle..	Check/replace as necessary.
	6. Clean relay opening during cycle..	Check operation and voltage during cycle. Replace if coil voltage is present but relay contacts do not close.
	7. Voltage too low during cycle..	Have electrical service checked for "peak" voltage drop.
Door will not lock	1. Thermostat lock..	Replace thermostat.

<u>Condition</u>	<u>Possible Cause</u>	<u>Correction</u>
Door will not lock (continued...)	2. Solenoid or solenoid latch switch..	Replace solenoid or solenoid switch.
	3. Clean relay..	Replace clean relay.
Door will not unlock	1. Latch mechanism..	Replace latch mechanism.
	2. Thermostat..	Replace thermostat.
	3. Clean relay..	Replace clean relay.
	4. Solenoid or solenoid latch switch..	Replace solenoid or solenoid latch switch.
Not broiling properly or not at all	1. Broil element open..	Replace boil element.
	2. Broil relay..	Replace broil relay.
	3. Limiter open..	Replace limiter.
	4. Thermostat..	Replace thermostat.
	5. Selector..	Replace selector.
	6. Door left closed (electronic models only)..	Door should be left open at broil stop position.
Blower shuts off during operation or not exhausting properly	1. Filter positioned incorrectly, or dirty..	Position filter so that it slants downward to the R.H. side of plenum chamber. Clean filter.
	2. Duct system not in accordance with recommended specifications. (Warranty not applicable.) Blower scroll reversed, duct length too long or improper size, too many elbows, excessive flex duct, joints not taped, restriction in ducting or wall cap, motor foam seal missing, improper transitions, inadequate make-up air..	Correct as necessary. NOTE: If alteration in the ducting system is required, advise customer of exact changes necessary and refer to installer.
Element does not heat	1. Circuit breaker or fuse blown..	Replace as necessary.
	2. Inoperative infinite switch..	Remove cartridge, turn infinite switch to high, check voltage at range receptacle.
	3. Open element..	Replace as necessary.
	4. Open wiring..	Replace as necessary.
Element shuts off during cooking cycle	1. Thermal limiter opening due to excessive heat buildup. Improper cookware, etc...	Check and replace if necessary. Advise customer to review U & C manual.

Condition

Cooling fan does not run during grilling (some updraft models)

Possible Cause

1. Grill element shunt clip missing.
2. Fan motor inoperative..
3. Wiring to fan open..
4. Fan blade binding..

Correction

- Install clip.
- Replace.
- Check and repair as necessary.
- Reposition fan assembly blade.

Section 4. Wiring & Specific Model Information

CDE852, CDE8520 Diagram

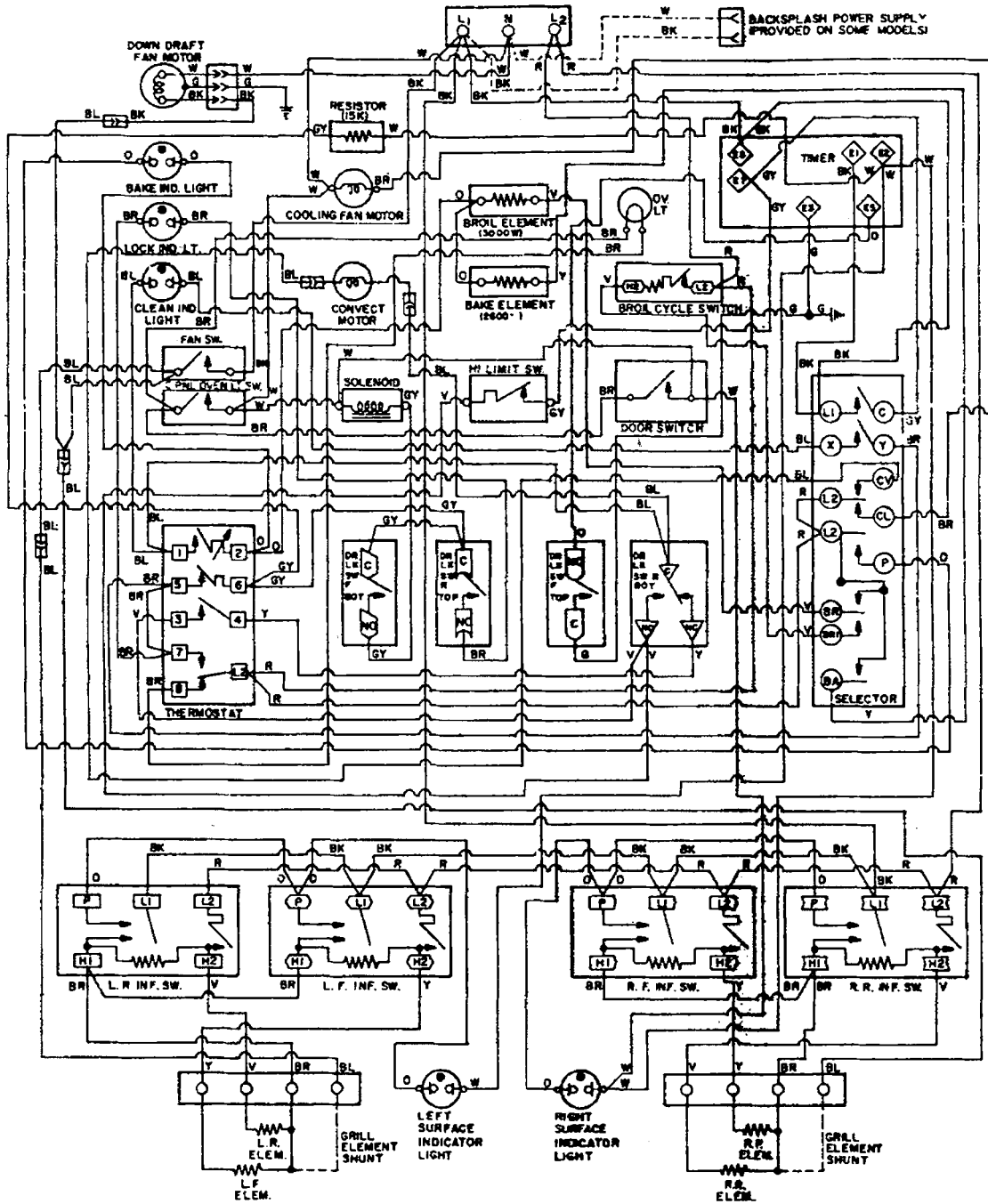

194 VR-0789

MAYTAG MODEL CDE852
ELECTRICAL SCHEMATIC

205090A

CDE852, CDE8520 Schematic

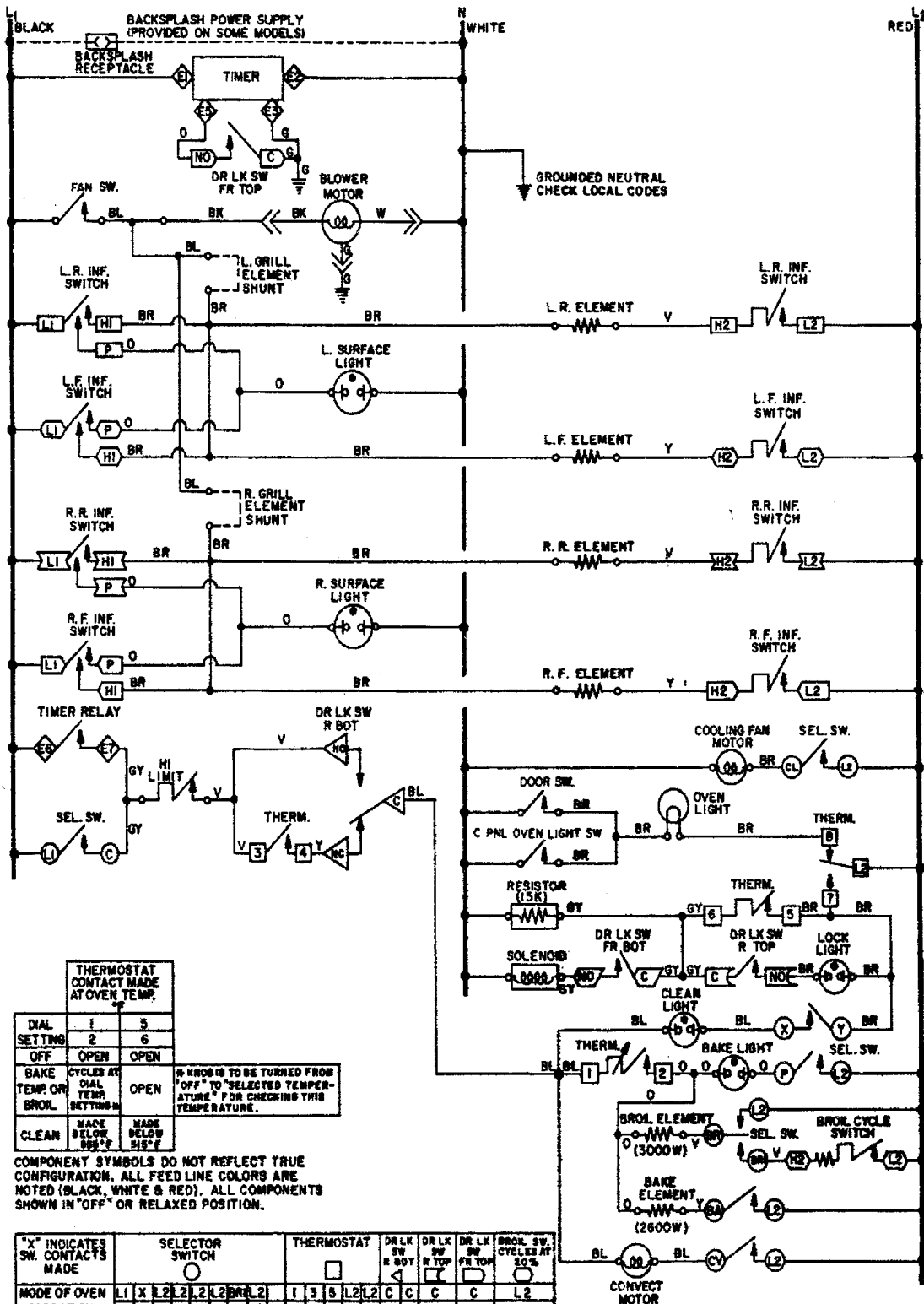

SCE30500 Diagram

FAULT CODES	PROBLEM	COMPONENTS TO CHECK
F1	Power to element relay activated during time of day display.	J1, J2 wire harness connection to control shorted, If checks ok, change control
F2	Over temperature sensed	Ohm TEST SENSOR. If checks ok, change control 'See chart for sensor value'
F3	Open sensor.	Ohm sensor. See chart
F4	Shorted sensor.	Ohm sensor. See chart
F5	Over temperature	Ohm SENSOR. Check connection of SENSOR wire harness.
F7	Shorted key	Stuck Function Key on Control.
F9	Door Code.	Check Latch Assembly.

OVEN SENSOR
 SENSOR TYPE: RTD 1000ohm platinum
 CALIBRATION: 1454 ohms (350°F.)
 OVEN SENSOR RESISTANCE VS TEMP TABLE

Degrees F	Resistance
100	1143
200	1358
300	1553
350	1654
400	1753
500	1949
600	2142
700	2331
800	2516
900	2697
1000	2874

NOTE: For use by SERVICE PERSONNEL only.

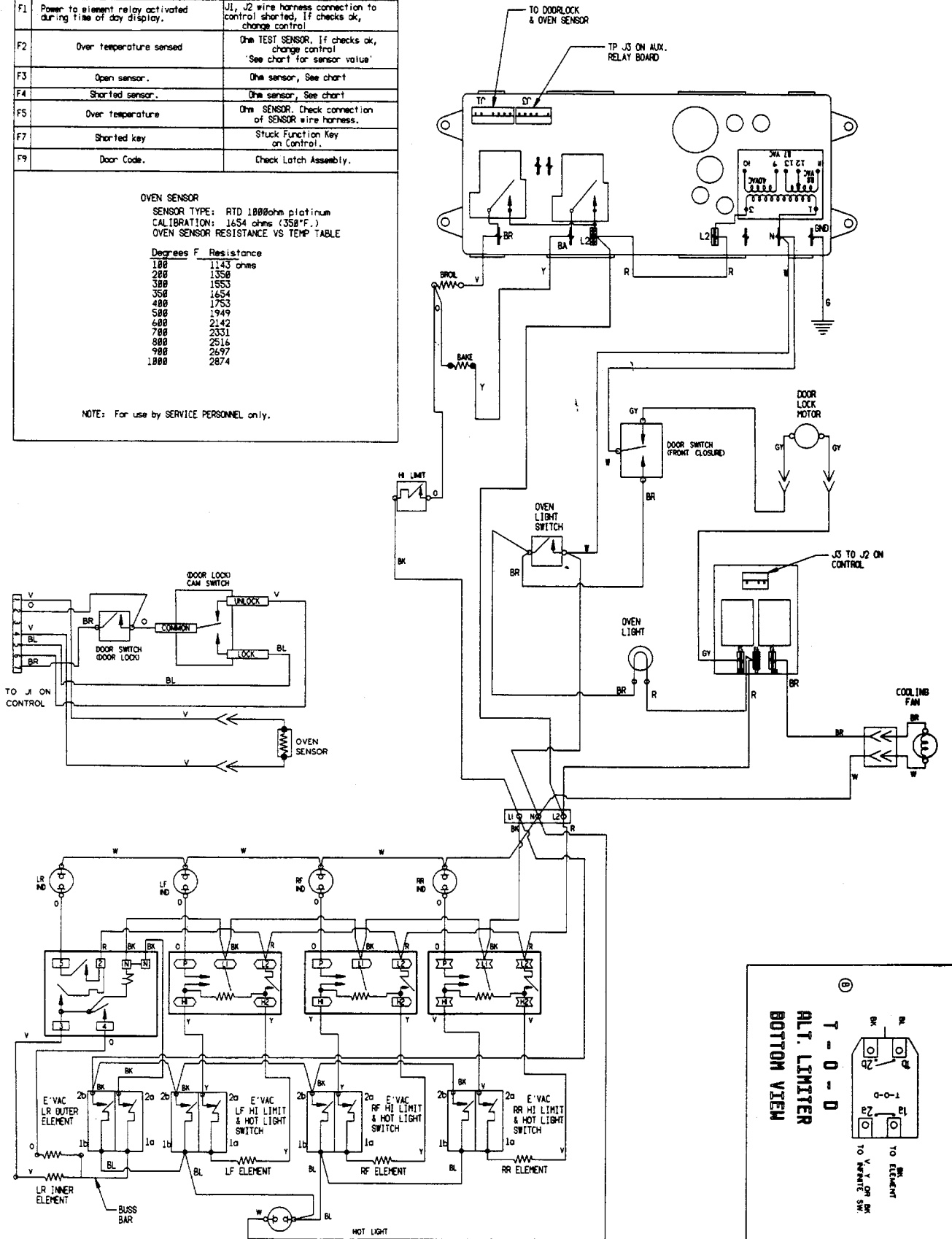

SCE30500 Schematic

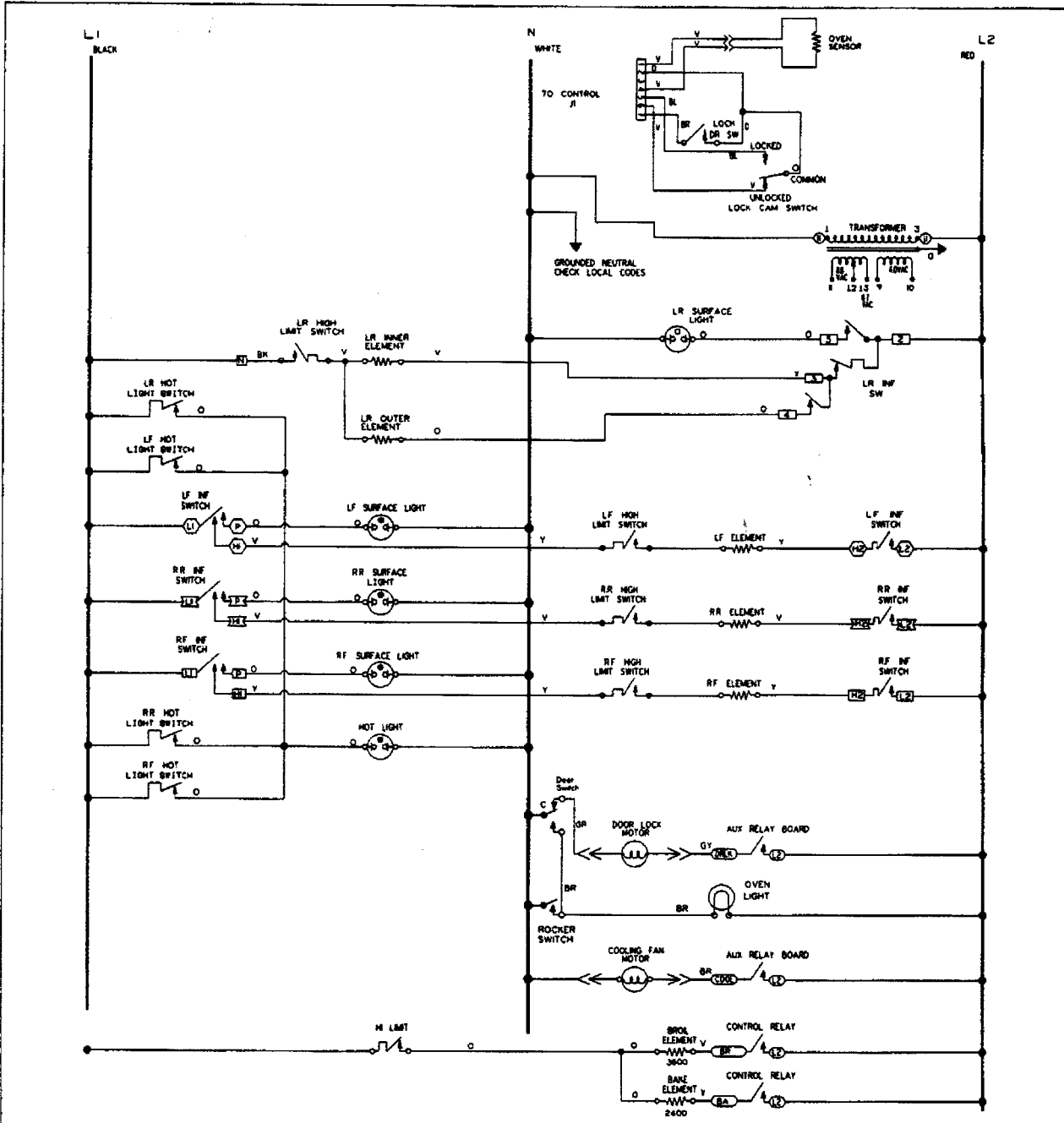

NOTE
THERE IS A RESISTANCE HEATER IN ALL
INFRA-RED CONTROLS BETWEEN H & HE
SEE REVERSE SIDE FOR DETAILS

COMPONENT SYMBOLS DO NOT REFLECT
TRUE CONFIGURATION. ALL FEED LINE
COLORS ARE NOTED (BLACK, WHITE &
RED). ALL COMPONENTS SHOWN IN
OFF OR RELAXED POSITION.

MODES OF OPERATION	AUX BOARD		CONTROL RELAY		Lock door switch with door		Cam Switch	
	L2	L2	L2	L2	Door shut	Door open	C	C
OFF					X		X	X
BAKE		ON AT 208" OFF AT 258"	Cycles	Cycles	X		X	X
TIMED BAKE		ON AT 208" OFF AT 258"	Cycles	Cycles	X		X	X
CLEAN		On with retraction Off at 258"	Cycles	Cycles	X		X	X
BROIL		On with retraction Off at 258"	X		X		X	X

SPECIFIC CYCLE RATES FOR EACH MODE & SPECIFIC
ELEMENT IS AVAILABLE FROM SERVICE

WIRE COLORS
B - RED
W - WHITE
BK - BLACK
G - GREEN
Y - YELLOW
BL - BLUE
BR - BROWN
O - ORANGE
GR - GRAY
V - YELLOW

SIDE NO 2

SCE30600 Schematic

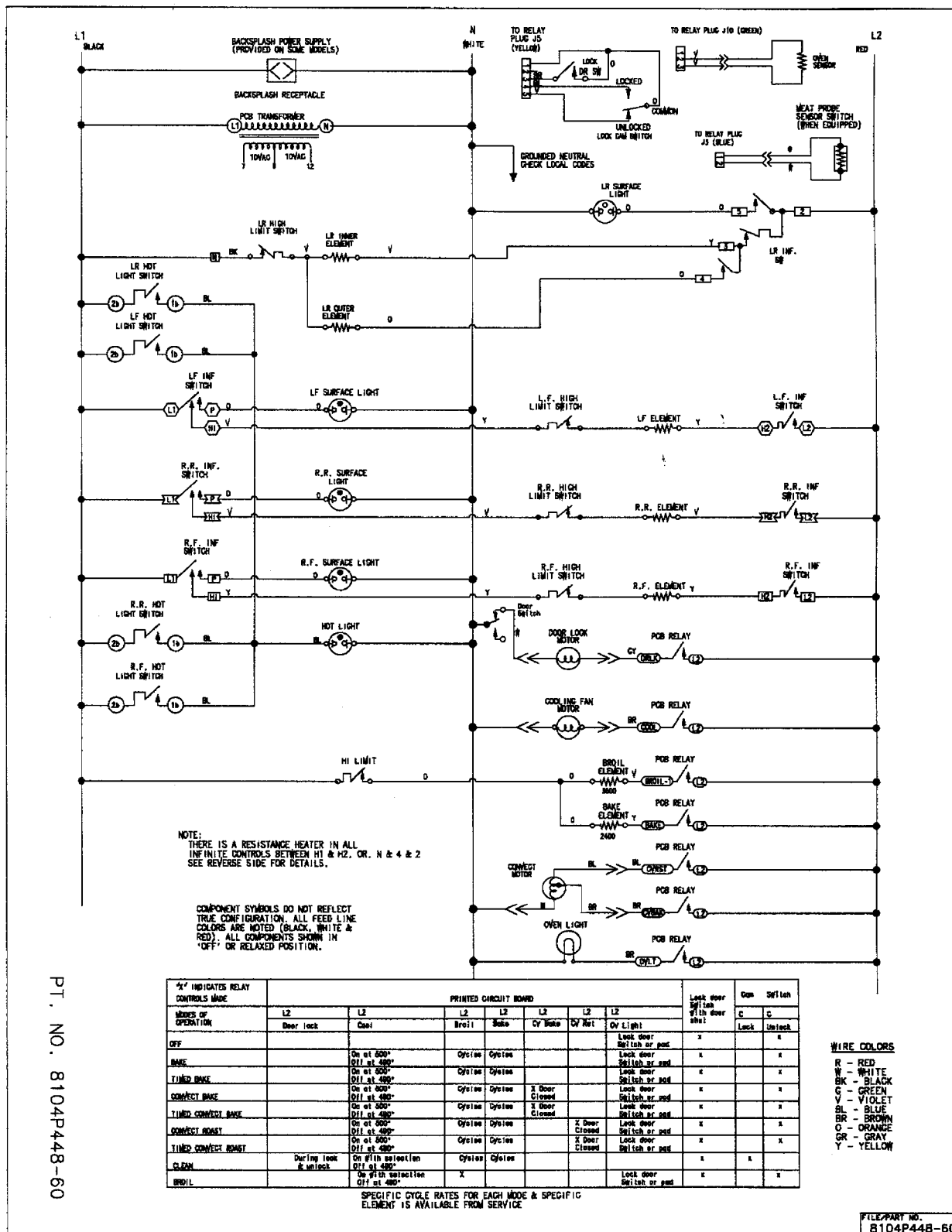

PT. NO. 8104P448-60

FILE/PART NO. 8104P448-60

SCE70600 Diagram

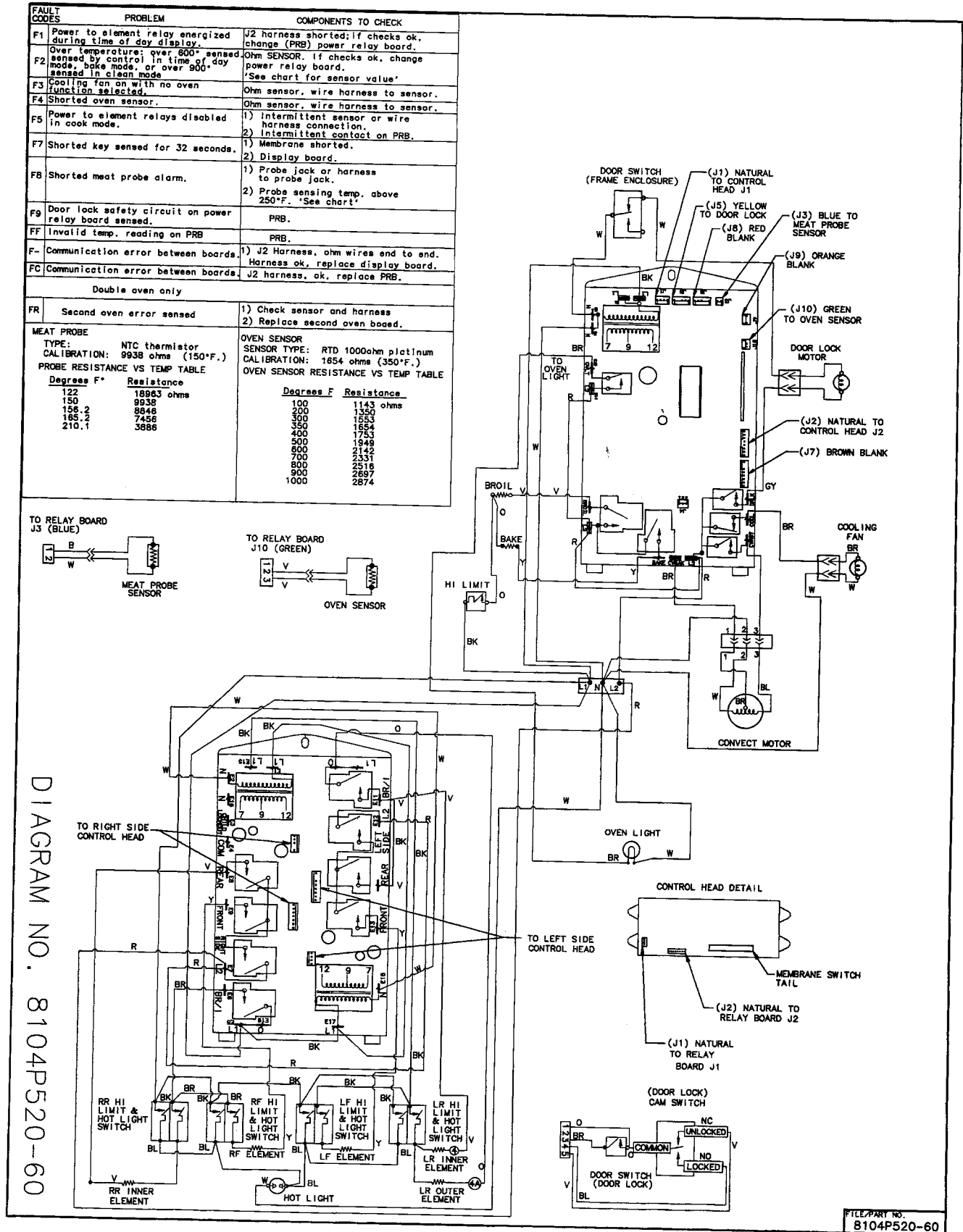

SCE7060 Schematic

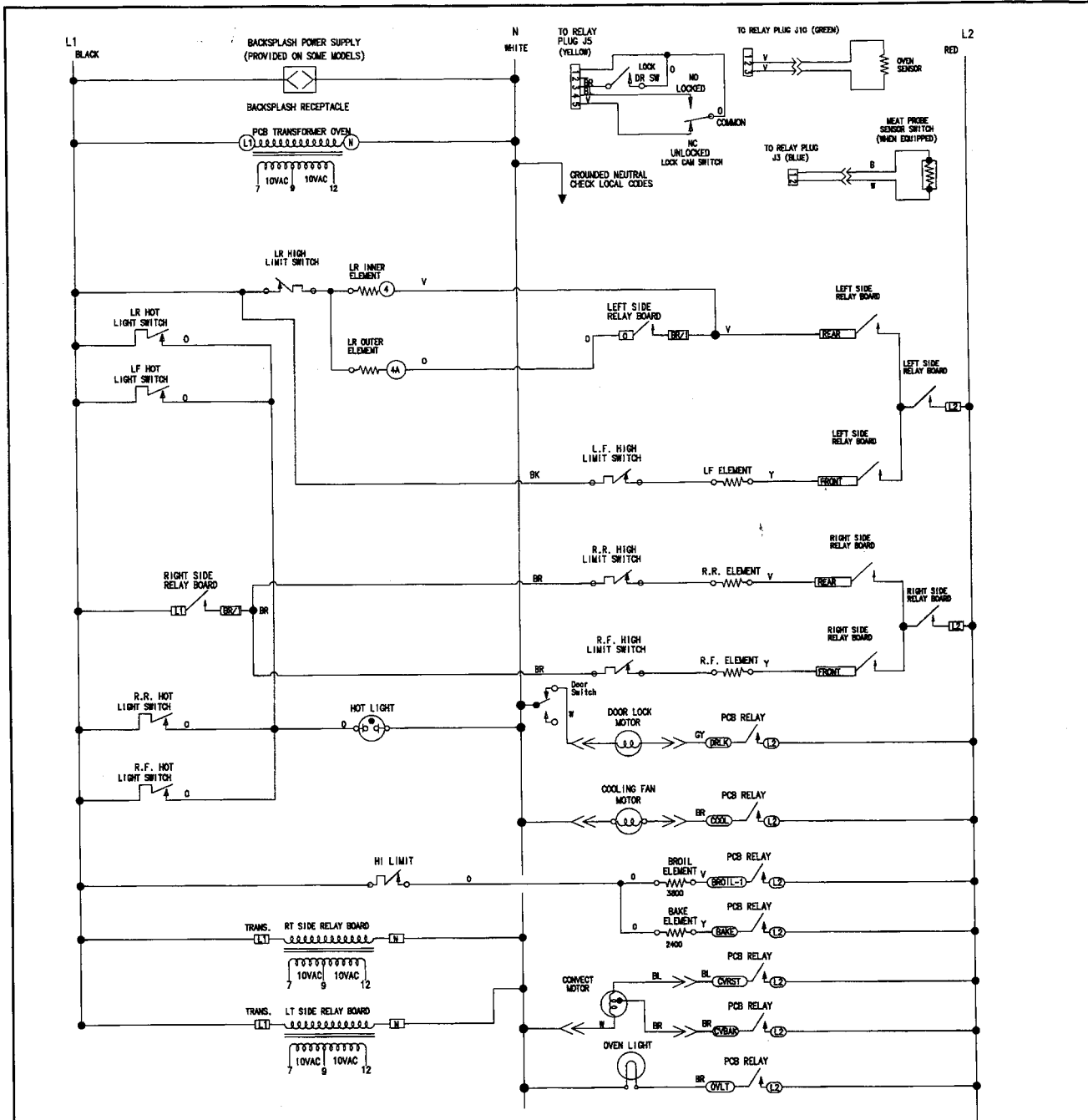

COMPONENT SYMBOLS DO NOT REFLECT TRUE CONFIGURATION. ALL FEED LINE COLORS ARE NOTED (BLACK, WHITE & RED). ALL COMPONENTS SHOWN IN "OFF" OR RELAXED POSITION.

NOTE: THERE IS A RESISTANCE HEATER IN ALL INFINITE CONTROLS BETWEEN H1 & H2, OR, W & 4 & 2. SEE REVERSE SIDE FOR DETAILS.

WIRE COLORS:
 R - RED
 W - WHITE
 BK - BLACK
 G - GREEN
 V - VIOLET
 BL - BLUE
 BR - BROWN
 O - ORANGE
 GR - GRAY
 Y - YELLOW

- NOTE:
- DISCONNECT RANGE FROM POWER BEFORE REMOVING WIRE COVER. REFER ONLY TO FEATURES EQUIPPED.
 - SERVICER PLEASE RETURN DIAGRAM TO RANGE.
 - CAUTION: LABEL ALL WIRES PRIOR TO DISCONNECTION WHEN SERVICING CONTROLS. WIRING PROBLEMS CAN CAUSE IMPROPER AND DANGEROUS OPERATION.

SPECIFIC CYCLE RATES FOR EACH MODE & SPECIFIC ELEMENT IS AVAILABLE FROM SERVICE.

MODES OF OPERATION	L2							Lock door Switch with door shut	Cam Switch	
	Door lock	Cool	Broil	Bake	Cv Bake	Cv Rot	Ov Light		C	C
BAKE		On at 500° Off at 490°	Cycles	Cycles				Lock door Switch or pad	x	x
TIMED BAKE		On at 500° Off at 490°	Cycles	Cycles				Lock door Switch or pad	x	x
CONNECT BAKE		On at 500° Off at 490°	Cycles	Cycles	X Door Closed			Lock door Switch or pad	x	x
TIMED CONNECT BAKE		On at 500° Off at 490°	Cycles	Cycles	X Door Closed			Lock door Switch or pad	x	x
CONNECT ROAST		On at 500° Off at 490°	Cycles	Cycles		X Door Closed		Lock door Switch or pad	x	x
TIMED CONNECT ROAST		On at 500° Off at 490°	Cycles	Cycles		X Door Closed		Lock door Switch or pad	x	x
CLEAN	During lock & unlock	On with selection Off at 490°	Cycles	Cycles				Lock door Switch or pad	x	x
BROIL		On with selection Off at 490°	X					Lock door Switch or pad	x	x

FILE/PART NO.
8104P520

SEG196 Diagram

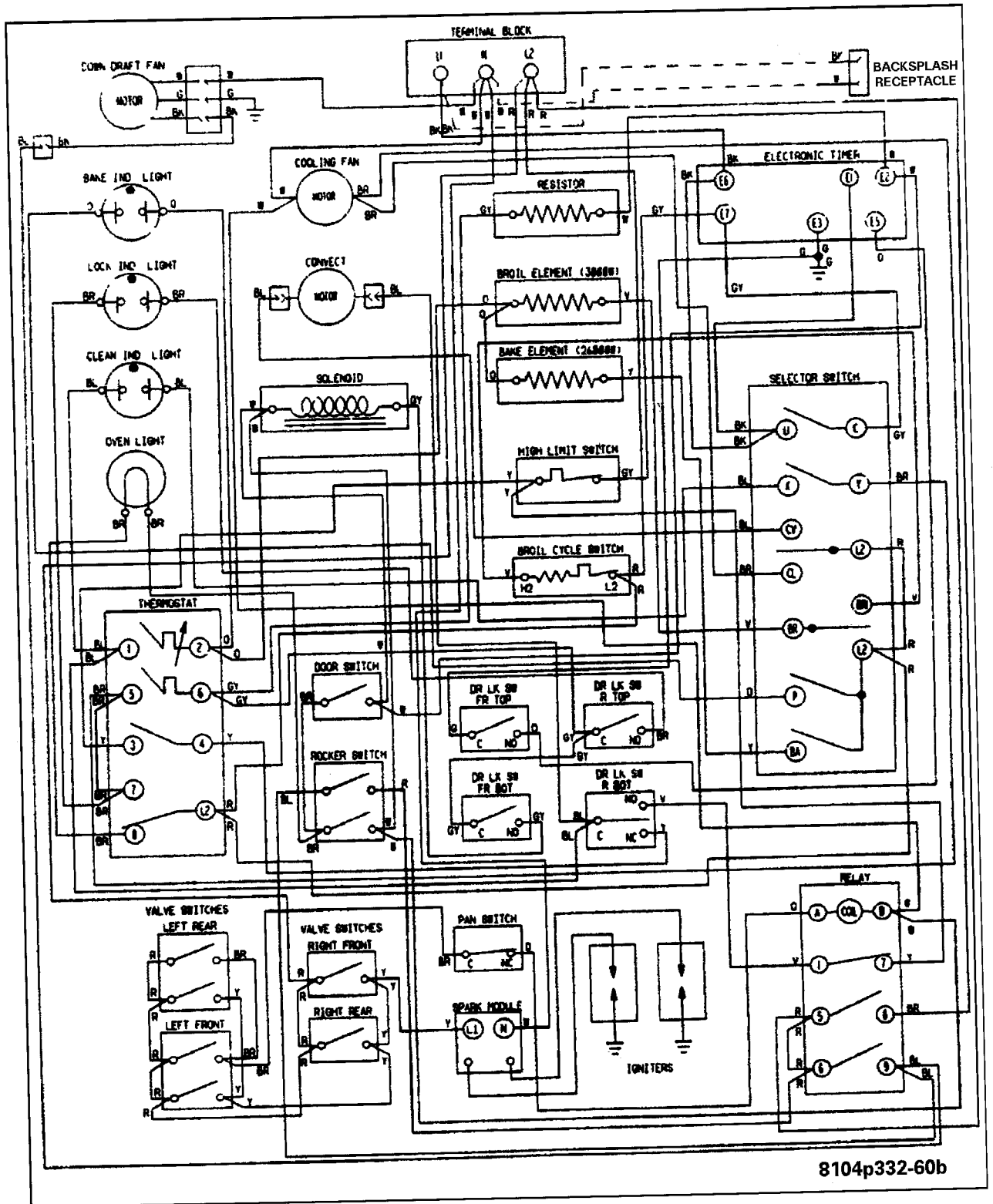

SEG196 Schematic

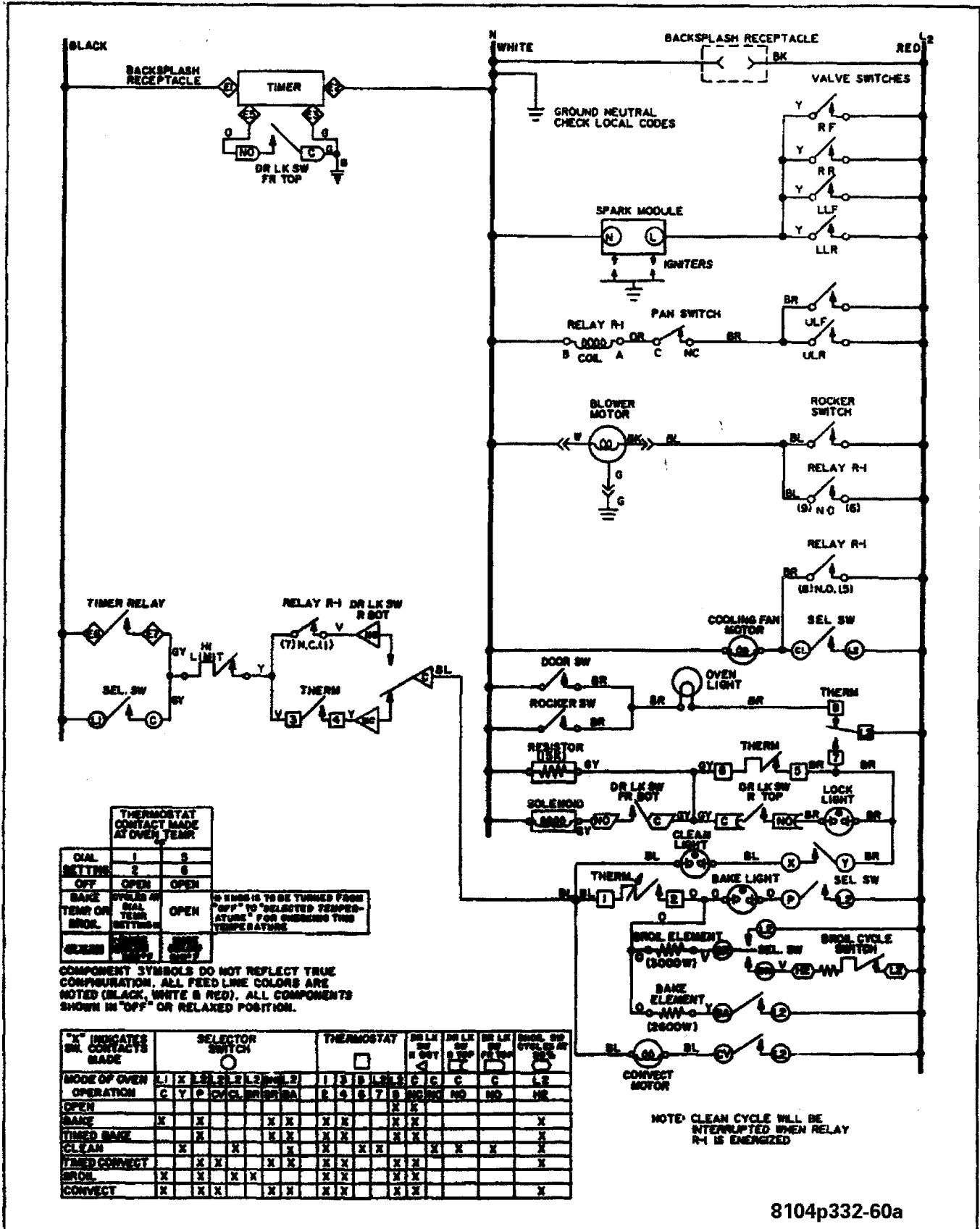

THERMOSTAT CONTACT MADE AT OVER TEMP
 DIAL SETTINGS: 1, 5, 2, 6, OFF, OPEN, OPEN
 BAKE TEMP OR BROIL SETTINGS: OPEN
 * THERM IS TO BE TURNED FROM "OFF" TO "SELECTED TEMPERATURE" FOR CHANGING THIS TEMPERATURE

COMPONENT SYMBOLS DO NOT REFLECT TRUE CONFIGURATION. ALL FEED LINE COLORS ARE NOTED (BLACK, WHITE & RED). ALL COMPONENTS SHOWN IN "OFF" OR RELAXED POSITION.

"X" INDICATES SWL CONTACTS MADE	SELECTOR SWITCH				THERMOSTAT								DR LK SW N OUT	DR LK SW B TOP	DR LK SW FR TOP	DR LK SW FR BOT
	C	Y	P	CYCL	1	2	3	4	5	6	7	8	9	NO	NO	NR
OPEN																
BAKE	X	X			X	X	X	X	X	X	X	X				X
TIMED BAKE	X	X			X	X	X	X	X	X	X	X				X
CLEAN	X	X	X		X	X	X	X	X	X	X	X	X	X	X	X
TIMED CONVECT		X	X		X	X	X	X	X	X	X	X				X
BROIL	X	X	X	X	X	X	X	X	X	X	X	X				X
CONVECT	X	X	X		X	X	X	X	X	X	X	X				X

8104p332-60a

SEG196*C Diagram

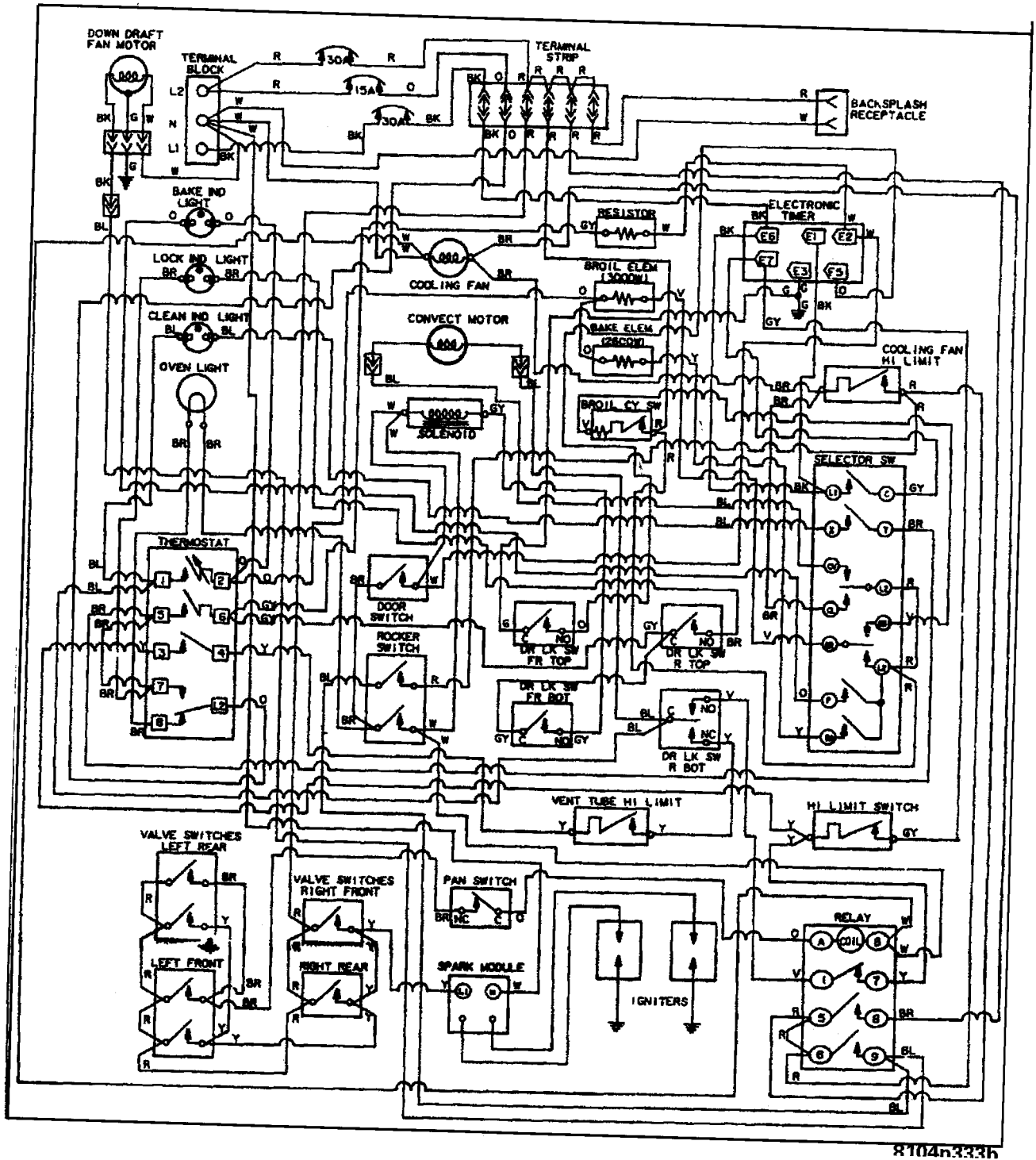

SVD8310S Diagram

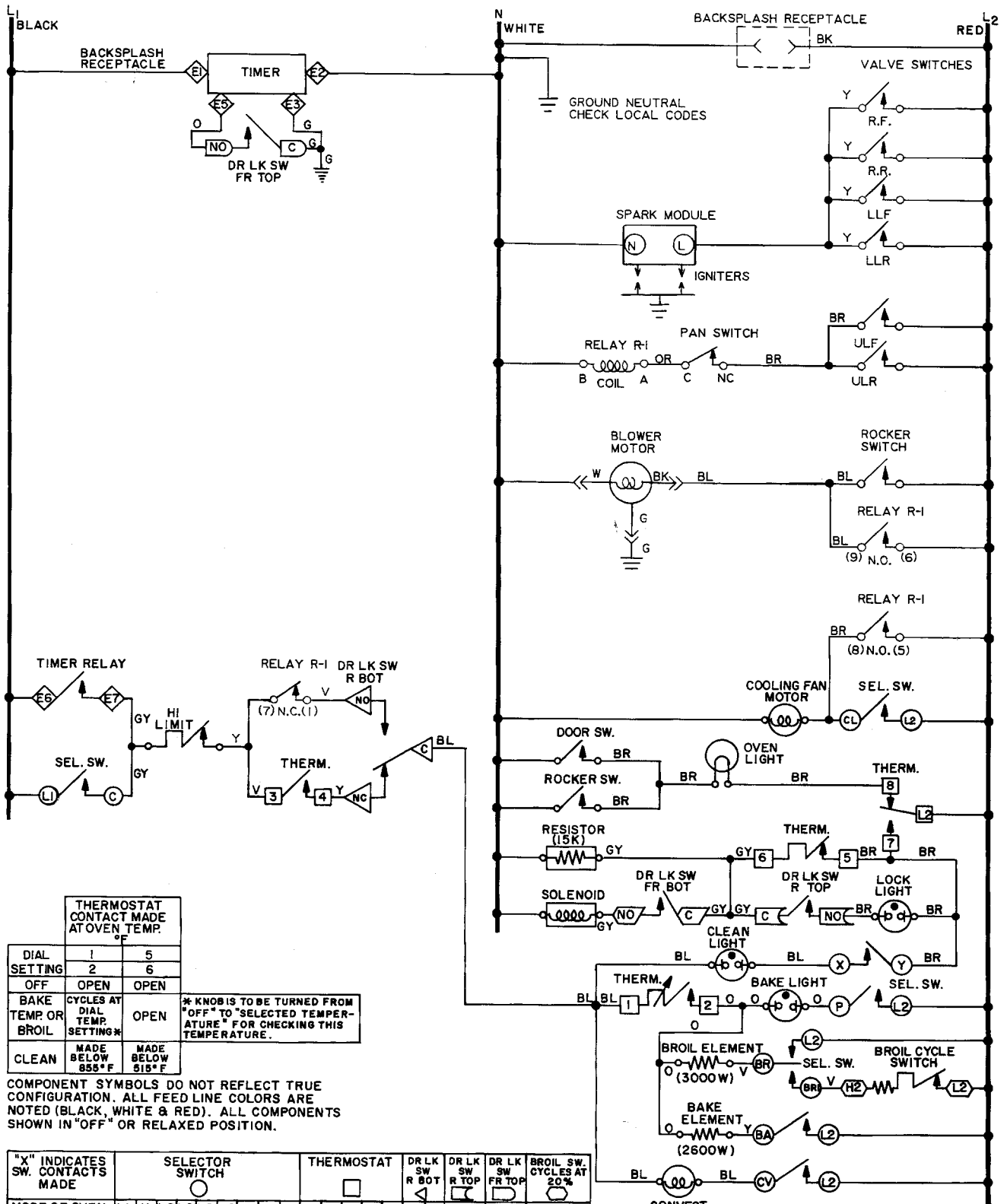

NOTE: CLEAN CYCLE WILL BE INTERRUPTED WHEN RELAY R-1 IS ENERGIZED.

SVD8310S Schematic

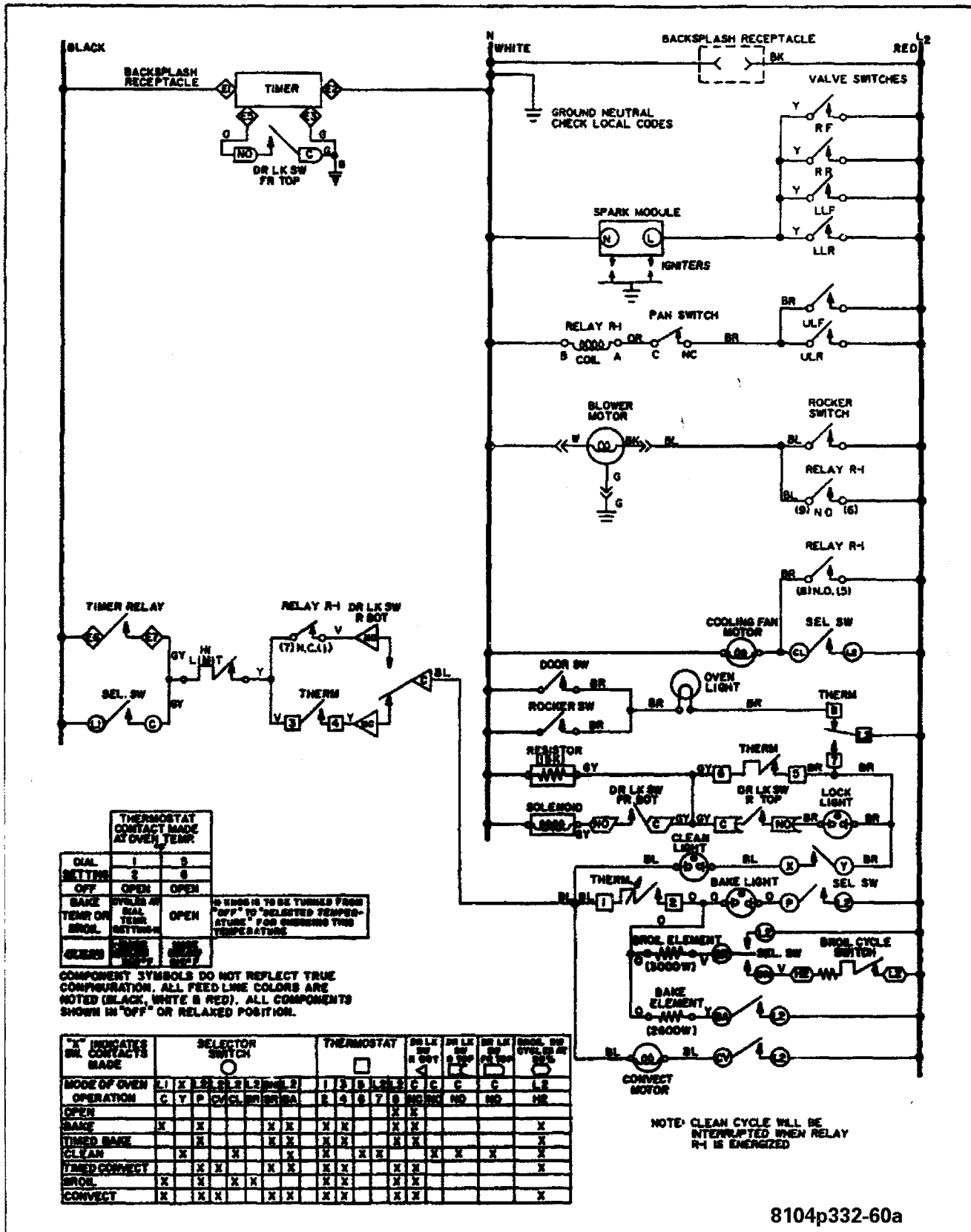

THERMOSTAT CONTACT MADE AT OVEN TEMP.		
DIAL SETTINGS	1	2
OFF	OPEN	OPEN
BAKE TEMP OR BROIL	OVENS IN REAL TEMP SETTINGS	OPEN
OVENS	OVENS IN REAL TEMP SETTINGS	OVENS IN REAL TEMP SETTINGS

NO BAKE IS TO BE TURNED FROM "OFF" TO "SELECTED TEMPERATURE" FOR CHANGING THIS TEMPERATURE

COMPONENT SYMBOLS DO NOT REFLECT TRUE CONFIGURATION. ALL FEED LINE COLORS ARE NOTED (BLACK, WHITE & RED). ALL COMPONENTS SHOWN IN "OFF" OR RELAXED POSITION.

MODE OF OVEN OPERATION	SELECTOR SWITCH						THERMOSTAT								DR LK SW FR BOT		DR LK SW R TOP		DR LK SW FR TOP		BROIL CYCLE ON/OFF					
	L1	X	L2	L3	L4	L5	1	2	3	4	5	6	7	8	9	10	C	C	C	C	NO	NO	NO	NO		
OFF																										
BAKE	X		X				X	X	X	X	X	X	X	X	X	X	X	X	X	X						X
TIMED BAKE			X				X	X	X	X	X	X	X	X	X	X	X	X	X	X						X
CLEAN		X		X			X	X	X	X	X	X	X	X	X	X	X	X	X	X						X
TIMED CONNECT			X	X	X		X	X	X	X	X	X	X	X	X	X	X	X	X	X						X
BROIL	X		X		X	X	X	X	X	X	X	X	X	X	X	X	X	X	X	X						X
CONNECT	X		X	X			X	X	X	X	X	X	X	X	X	X	X	X	X	X						X

SVD48600 Diagram

FAULT CODES	PROBLEM	COMPONENTS TO CHECK
F1	Power to element relay energized during time of day display.	J2 harness shorted; if checks ok, change (PRB) power relay board.
F2	Over temperature; over 600° sensed by control in time of day mode, bake mode, or over 600° sensed in clean mode.	Ohm SENSOR. If checks ok, change power relay board. *See chart for sensor values*
F3	Cooling fan on with no oven function selected.	Ohm sensor, wire harness to sensor.
F4	Shorted oven sensor.	Ohm sensor, wire harness to sensor.
F5	Power to element relays disabled in cook mode.	1) Intermittent sensor or wire harness connection. 2) Intermittent contacts on PRB.
F7	Shorted key sensed for 32 seconds.	1) Membrane shorted. 2) Display board.
F8	Shorted meat probe alarm.	1) Probe jack or harness to probe jack. 2) Probe sensing temp. above 250°F. *See chart*
F9	Door lock safety circuit on power relay board sensed.	PRB.
FF	Invalid temp. reading on PRB.	PRB.
F-	Communication error between boards.	J2 harness, ohm wires end to end. Harness ok, replace display board.
FC	Communication error between boards.	J2 harness, ok, replace PRB.
	Double oven only	
FR	Second oven error sensed.	1) Check sensor and harness 2) Replace second oven board.

MEAT PROBE		OVEN SENSOR	
TYPE: NTC thermistor		SENSOR TYPE: RTD 1000ohm platinum	
CALIBRATION: 9838 ohm (150°F)		CALIBRATION: 1854 OHMS (350°F.)	
OVEN SENSOR RESISTANCE VS TEMP TABLE			
PROBE RESISTANCE VS TEMP TABLE		Degrees F	
Resistance	Resistance	Resistance	Resistance
100	100	1143 ohm	1350
122	18663 ohm	300	1553
150	9838	350	1654
156.2	8846	400	1753
165.2	7458	500	1949
210.1	3686	600	2142
		700	2331
		800	2516
		900	2697
		1000	2874

DIAGRAM NO. 8104P334-60

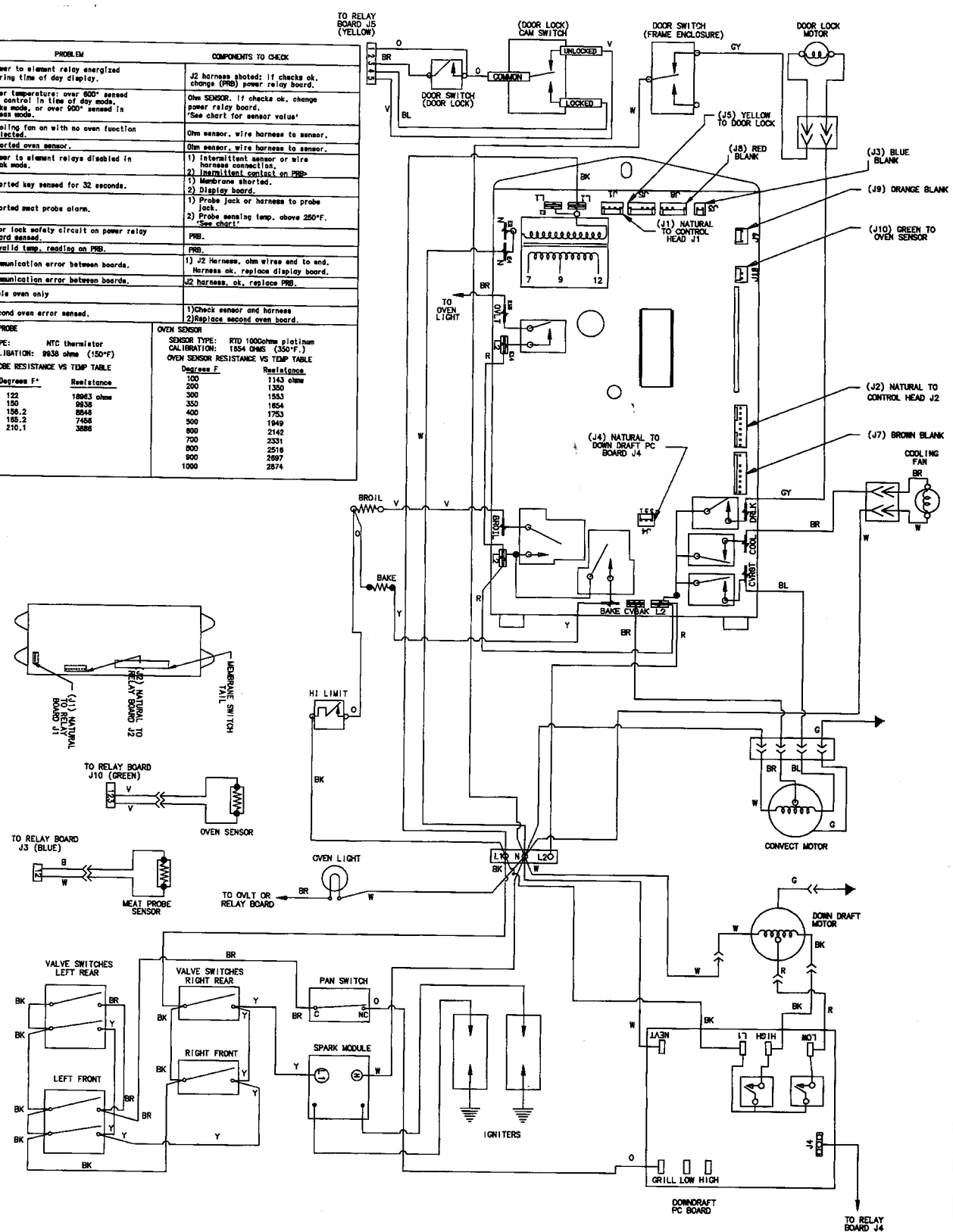

FILE/PART NO. 8104P334-60

SVD48600 Schematic

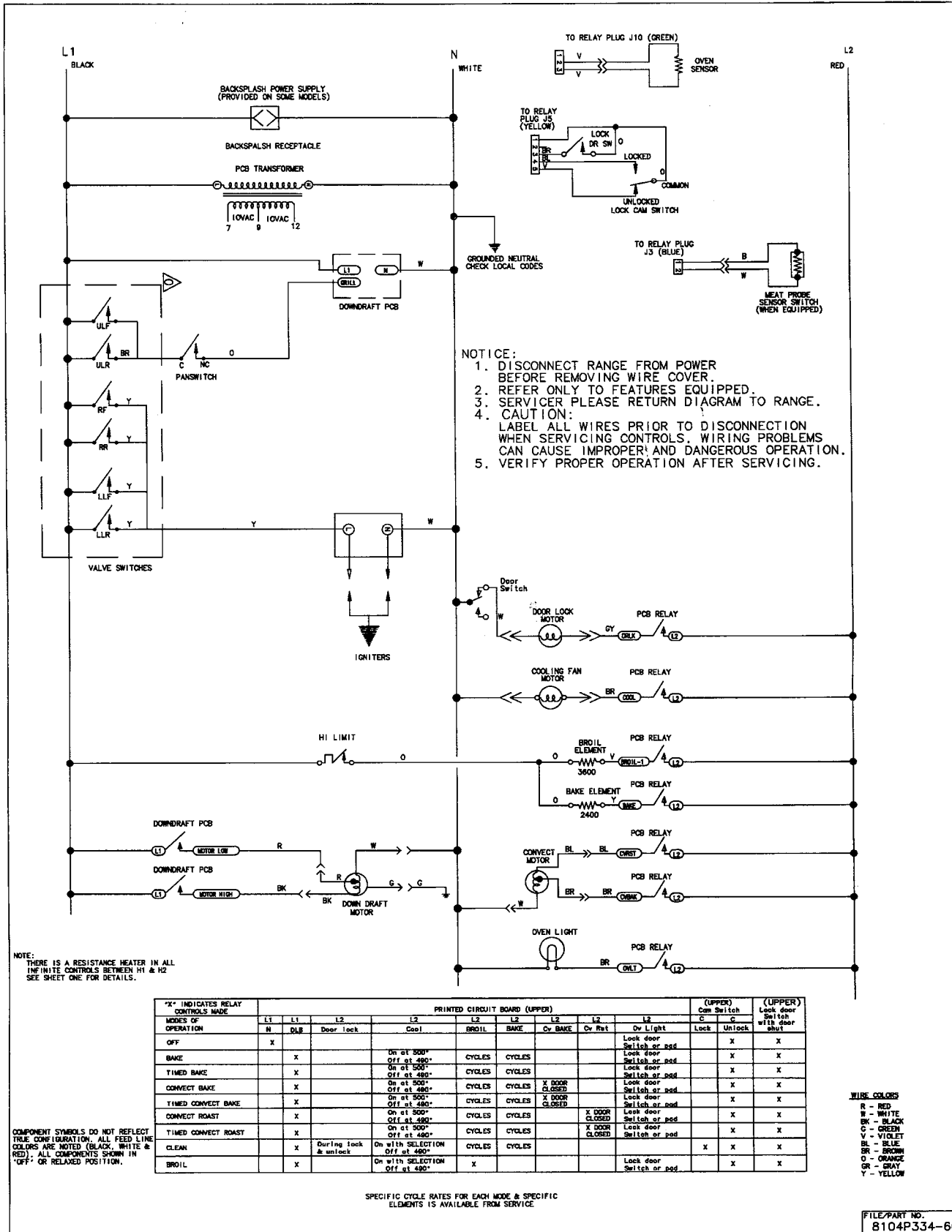

SVD48600*C Diagram

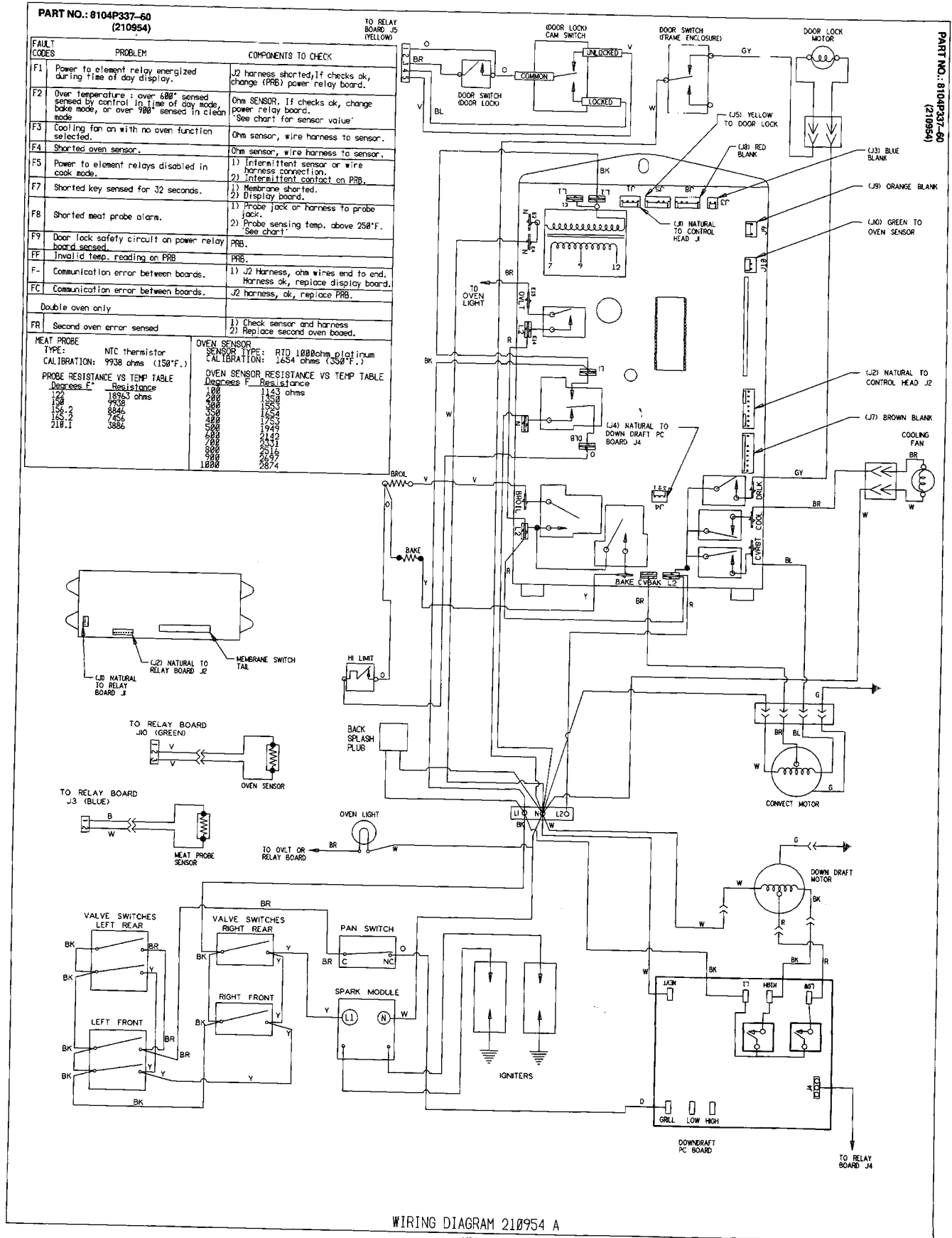

SVD48600*C Schematic

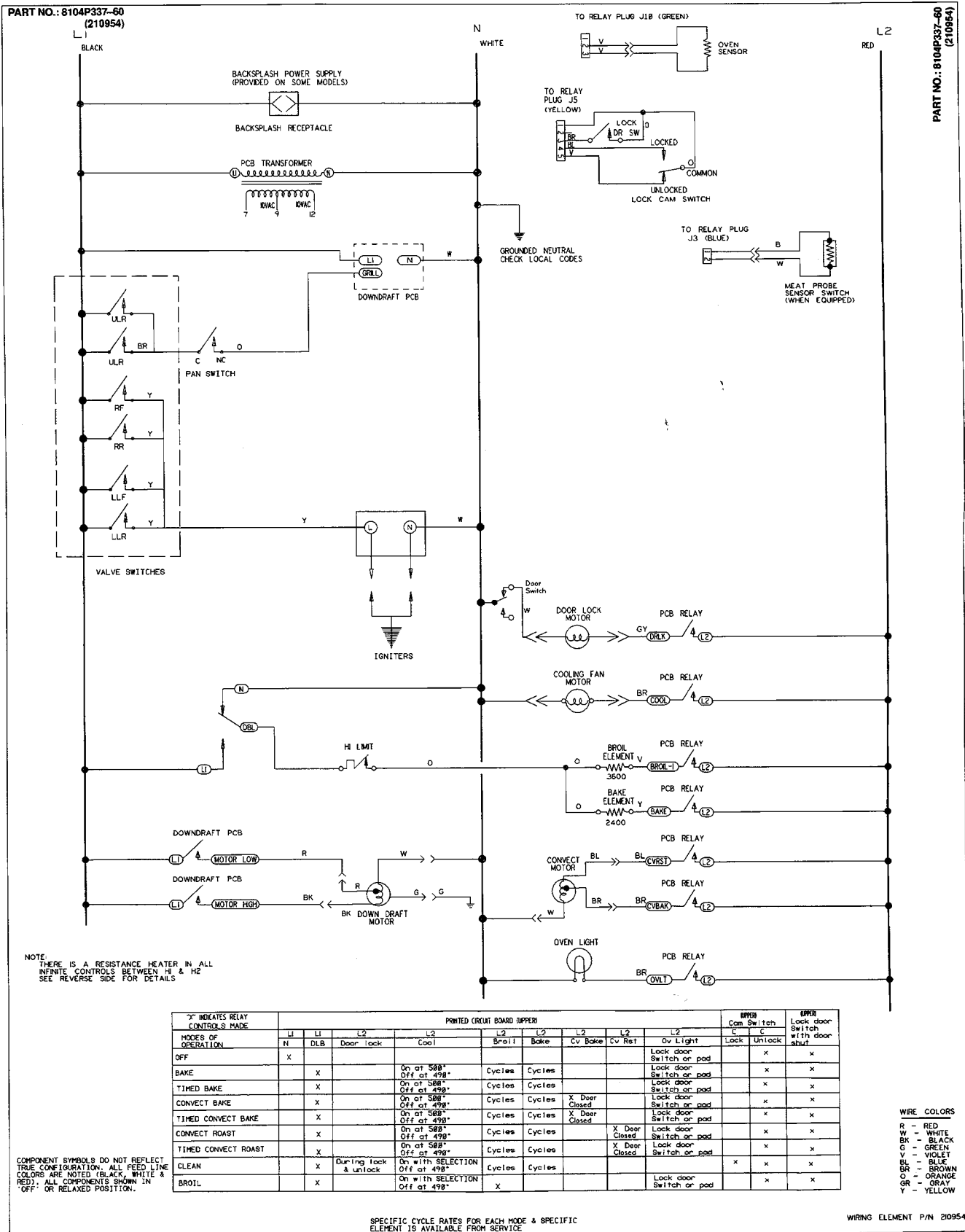

SVD48600P Diagram

FAULT CODES	PROBLEM	COMPONENTS TO CHECK
F1	Power to element relay activated during time of day display.	J1, J2 wire harness connection to control shorted, if checks ok, change control
F2	Over temperature sensed.	Ohm TEST SENSOR. If checks ok, change control 'See chart for sensor value'
	Open sensor.	Ohm sensor. See chart
F4	Shorted sensor.	Ohm sensor. See chart
F5	Over temperature	Ohm SENSOR. Check connection of SENSOR wire harness.
F7	Shorted key	Stuck Function Key on Control.
F9	Door Code.	Check Latch Assembly.

OVEN SENSOR

SENSOR TYPE: RTD 1000ohm platinum
 CALIBRATION: 1854 ohms (350°F.)
 OVEN SENSOR RESISTANCE VS TEMP TABLE

Degrees F	Resistance
100	1143 ohms
200	1350
300	1553
350	1654
400	1753
500	1949
600	2142
700	2331
800	2516
900	2697
1000	2874

NOTE: For use by SERVICE PERSONNEL only. OVEN SENSOR

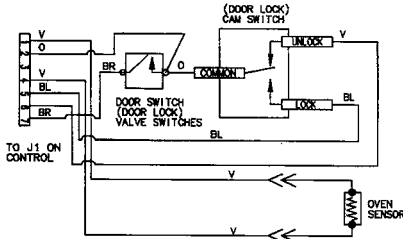

- NOTICE:**
- 1- DISCONNECT RANGE FROM POWER BEFORE REMOVING WIRE COVER.
 - 2- REFER ONLY TO FEATURES EQUIPPED.
 - 3- SERVICER PLEASE RETURN DIAGRAM TO RANGE.
 - 4- CAUTION: LABEL ALL WIRES PRIOR TO DISCONNECTION WHEN SERVICING CONTROLS. WIRING PROBLEMS CAN CAUSE IMPROPER AND DANGEROUS OPERATION.
 - 5- VERIFY PROPER OPERATION AFTER SERVICING.

DIAGRAM NO. 8104P510-60

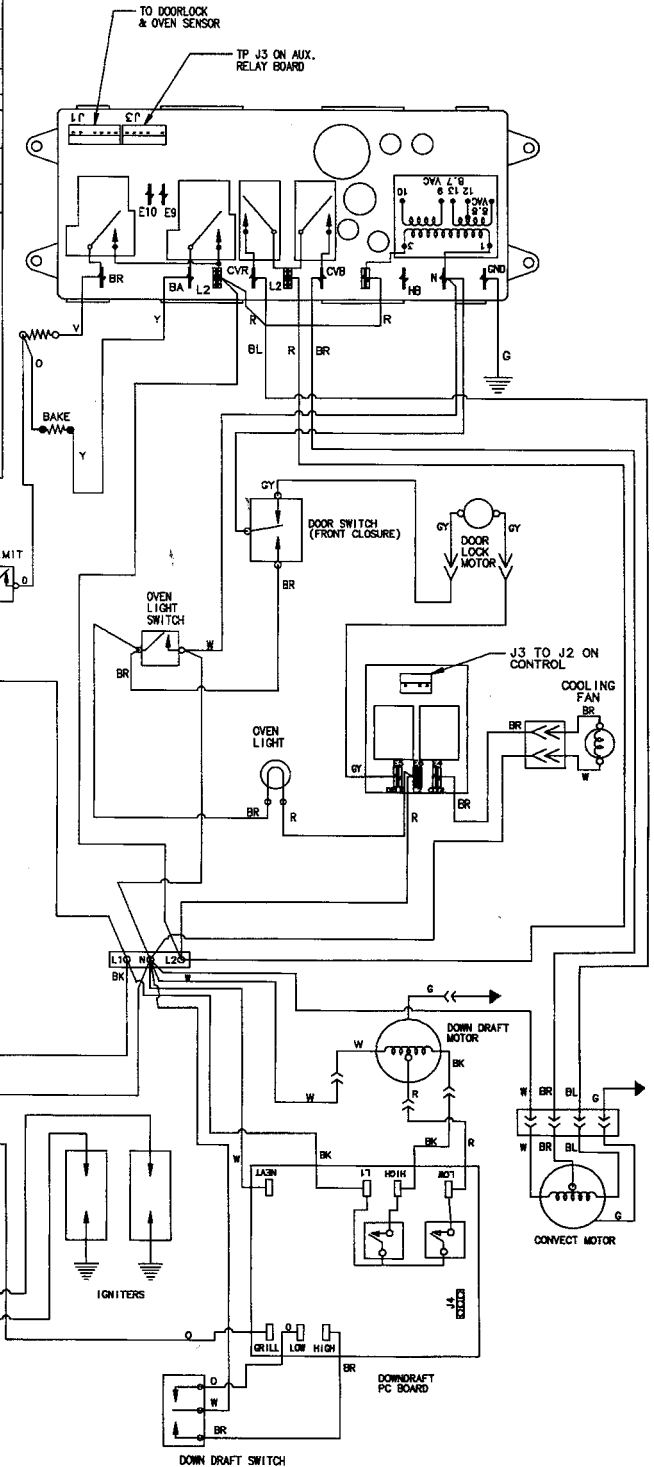

FILE/PART NO.
8104P510-60

SVD48600P Schematic

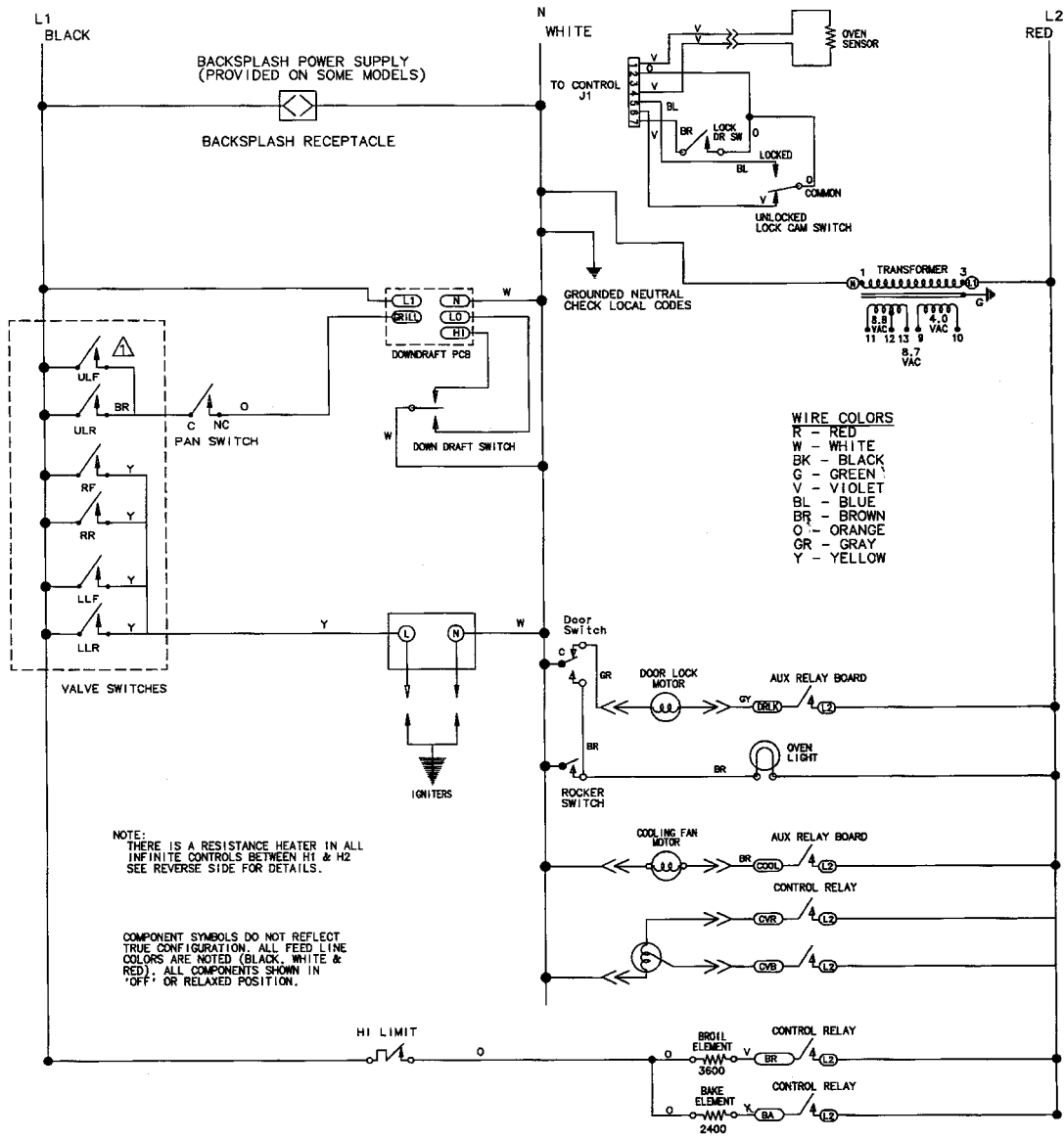

MODES OF OPERATION	L1	L1	L2	L2	L2	L2	L2	L2	L2	Lock door Switch with door shut	Cam Switch	
	N	DLB	Door lock	Cool	Broil	Bake	Cv Bake	Cv Rst	Ov Light		C	Lock
OFF	X											
BAKE		X		On at 500* Off at 490*	Cycles	Cycles				Lock door Switch or pad	x	x
TIMED BAKE		X		On at 500* Off at 490*	Cycles	Cycles				Lock door Switch or pad	x	x
CONVECT BAKE		X		On at 500* Off at 490*	Cycles	Cycles	X Door Closed			Lock door Switch or pad	x	x
TIMED CONVECT BAKE		X		On at 500* Off at 490*	Cycles	Cycles	X Door Closed			Lock door Switch or pad	x	x
CONVECT ROAST		X		On at 500* Off at 490*	Cycles	Cycles		X Door Closed		Lock door Switch or pad	x	x
TIMED CONVECT ROAST		X		On at 500* Off at 490*	Cycles	Cycles		X Door Closed		Lock door Switch or pad	x	x
CLEAN		X	During lock & unlock	On with selection Off at 490*	Cycles	Cycles				Lock door Switch or pad	x	x
BROIL		X		On with selection Off at 490*	X					Lock door Switch or pad	x	x

FILE/PART NO.
8104P510-60

SVD48600PC Diagram

FAULT CODES	PROBLEM	COMPONENTS TO CHECK
F1	Power to element relay activated during time of day display.	J1, J2 wire harness connection to control shorted, if checks ok, change control
F2	Over temperature sensed.	Ohm TEST SENSOR. If checks ok, change control 'See chart for sensor value'
	Open sensor.	Ohm sensor. See chart
F4	Shorted sensor.	Ohm sensor. See chart
F5	Over temperature	Ohm SENSOR. Check connection of SENSOR wire harness.
F7	Shorted key	Stuck Function Key on Control.
F9	Door Code.	Check Latch Assembly.

OVEN SENSOR

SENSOR TYPE: RTD 1000ohm platinum
 CALIBRATION: 1854 ohms (350°F.)
 OVEN SENSOR RESISTANCE VS TEMP. TABLE

Degree F	Resistance
100	1143 ohms
200	1350
300	1553
350	1654
400	1753
500	1949
600	2142
700	2331
800	2516
900	2697
1000	2874

NOTE: For use by SERVICE PERSONNEL only.

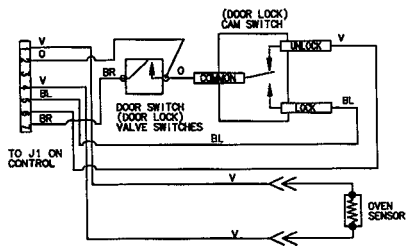

NOTICE:

- 1- DISCONNECT RANGE FROM POWER BEFORE REMOVING WIRE COVER.
- 2- REFER ONLY TO FEATURES EQUIPPED.
- 3- SERVICER PLEASE RETURN DIAGRAM TO RANGE.
- 4- CAUTION: LABEL ALL WIRES PRIOR TO DISCONNECTION WHEN SERVICING CONTROLS. WIRING PROBLEMS CAN CAUSE IMPROPER AND DANGEROUS OPERATION.

DIAGRAM NO. 8104P516-60

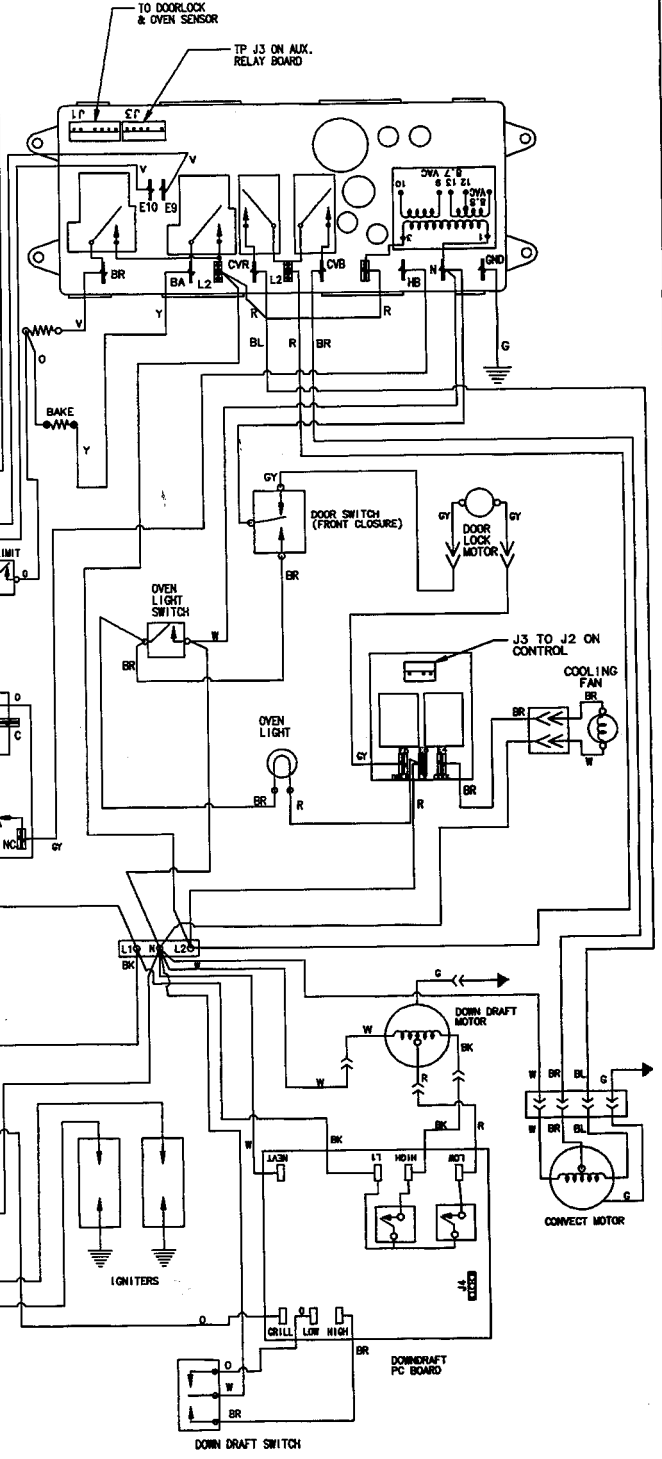
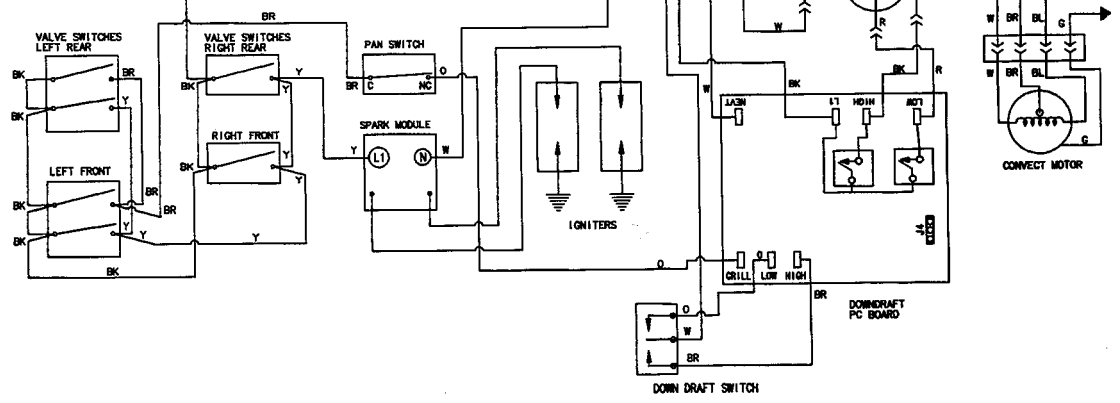

FILE/PART NO. 8104P516-60

SVD48600PC Schematic

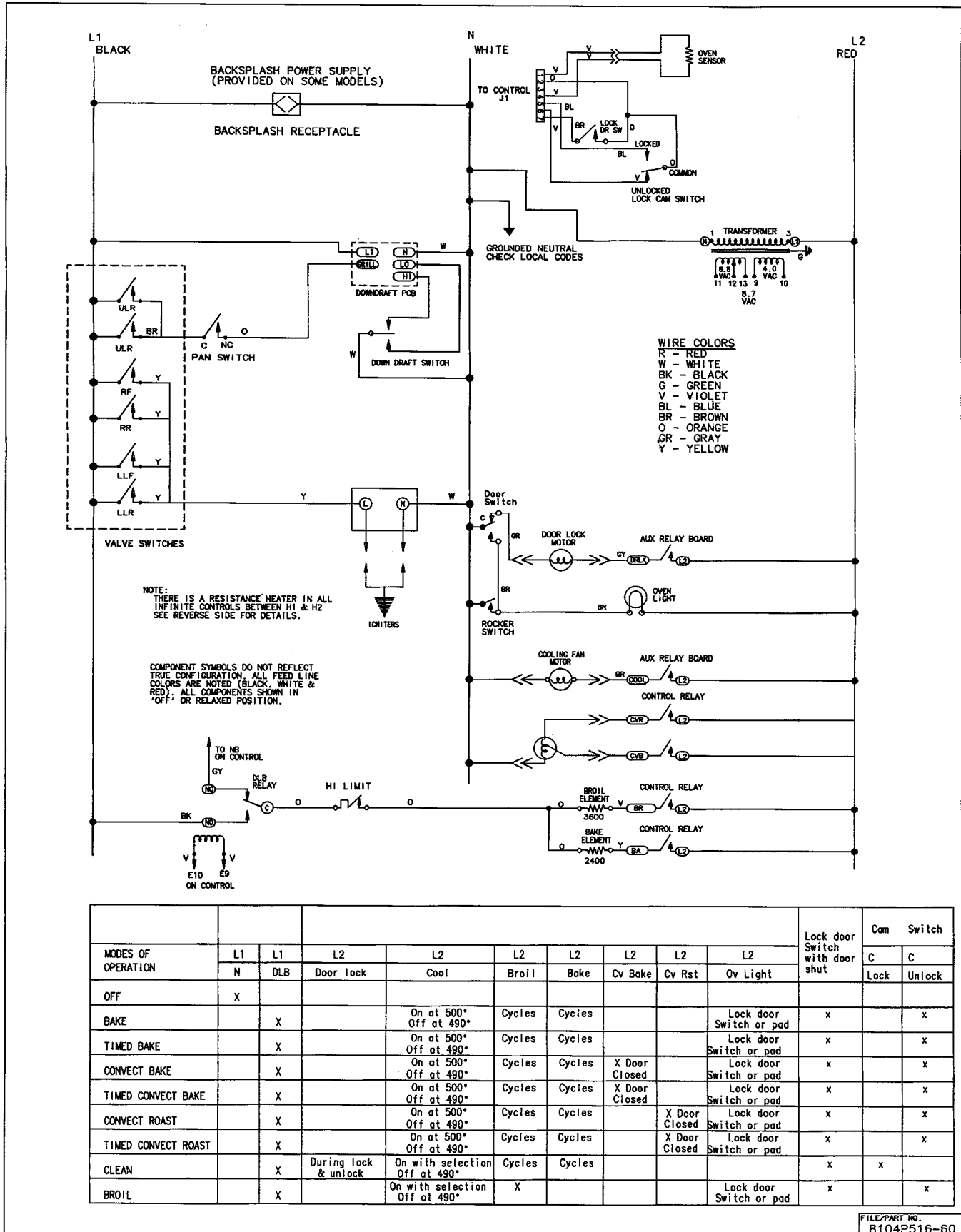

SVE47100 Diagram (Series 01)

FAULT CODES	PROBLEM	COMPONENTS TO CHECK
F1	Power to element relay activated during time of day display.	J1, J2 wire harness connection to control started. If checks ok, change control.
F2	Over temperature sensed	One TEST SENSOR. If checks ok, change control. 'See chart' for sensor value
	Open sensor.	One sensor. See chart
F4	Shorted sensor.	One sensor. See chart
F5	Over temperature	One SENSOR. Check connection of SENSOR wire harness.
F7	Shorted key	Stuck Function Key on Control.
F9	Door Code.	Check Latch Assembly.

OVEN SENSOR
 SENSOR TYPE: RTD 1000ohm platinum
 CALIBRATION: 1654 ohms (358°F.)
 OVEN SENSOR RESISTANCE VS TEMP TABLE

Degrees F	Resistance
100	1143 ohms
200	1350
300	1553
350	1654
400	1753
500	1949
600	2142
700	2331
800	2516
900	2697
1000	2874

NOTE: For use by SERVICE PERSONNEL only.

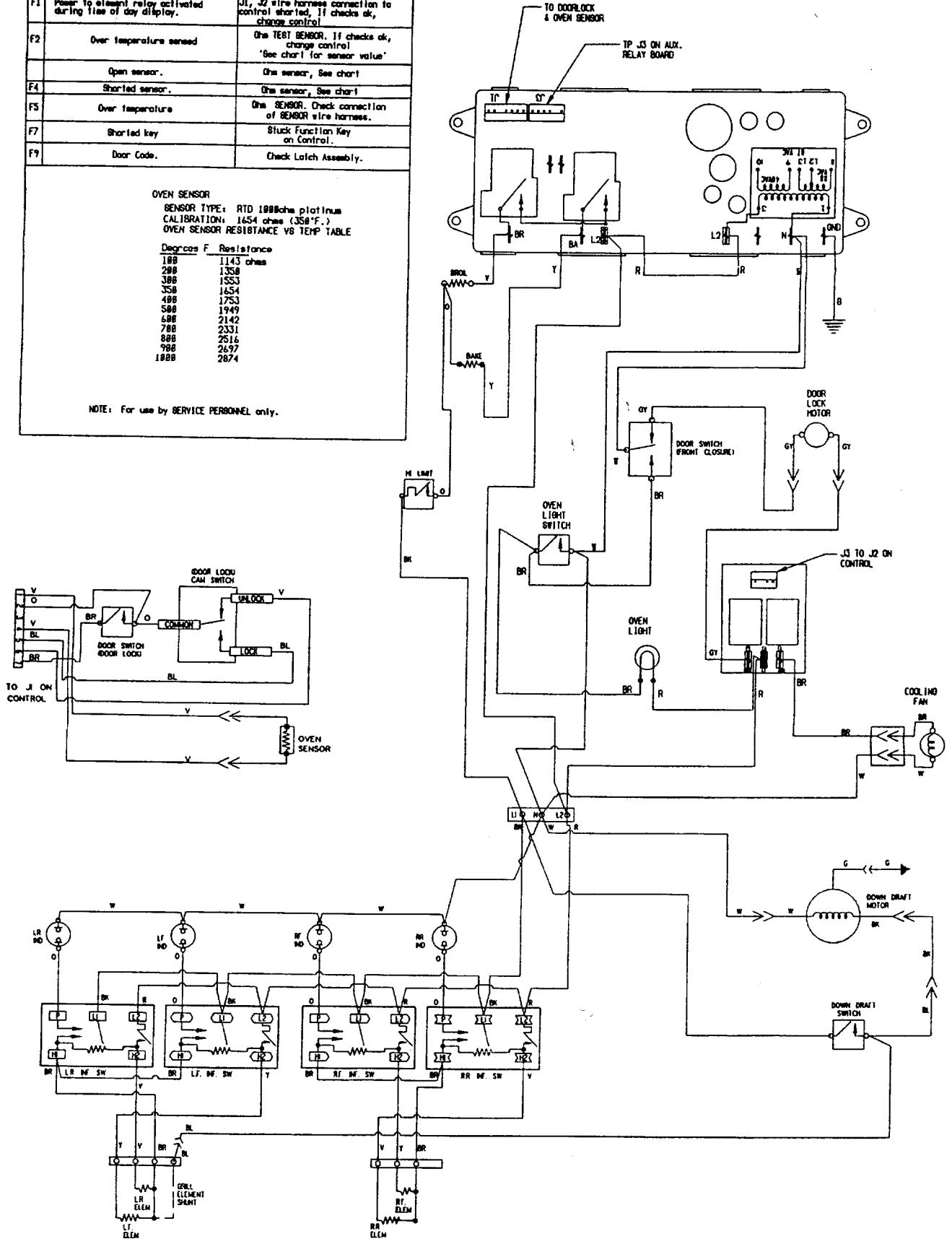

SVE47100 Diagram (Series 14)

- NOTICE:**
1. DISCONNECT RANGE FROM POWER BEFORE REMOVING WIRE COVER.
 2. REFER ONLY TO FEATURES EQUIPPED.
 3. SERVICER PLEASE RETURN DIAGRAM TO RANGE.
 4. LABEL ALL WIRES PRIOR TO DISCONNECTION.
 5. VERIFY PROPER OPERATION AFTER SERVICING.

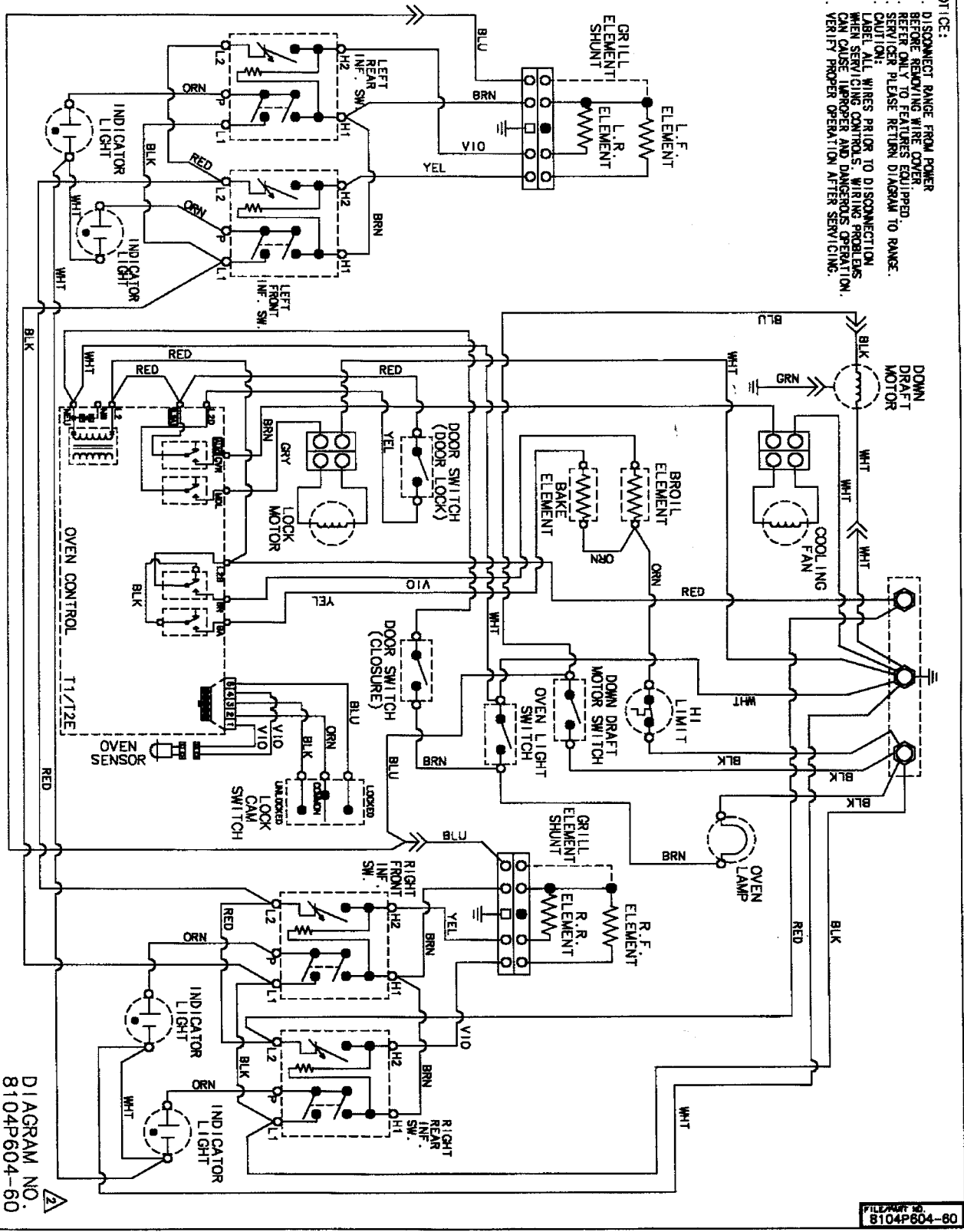
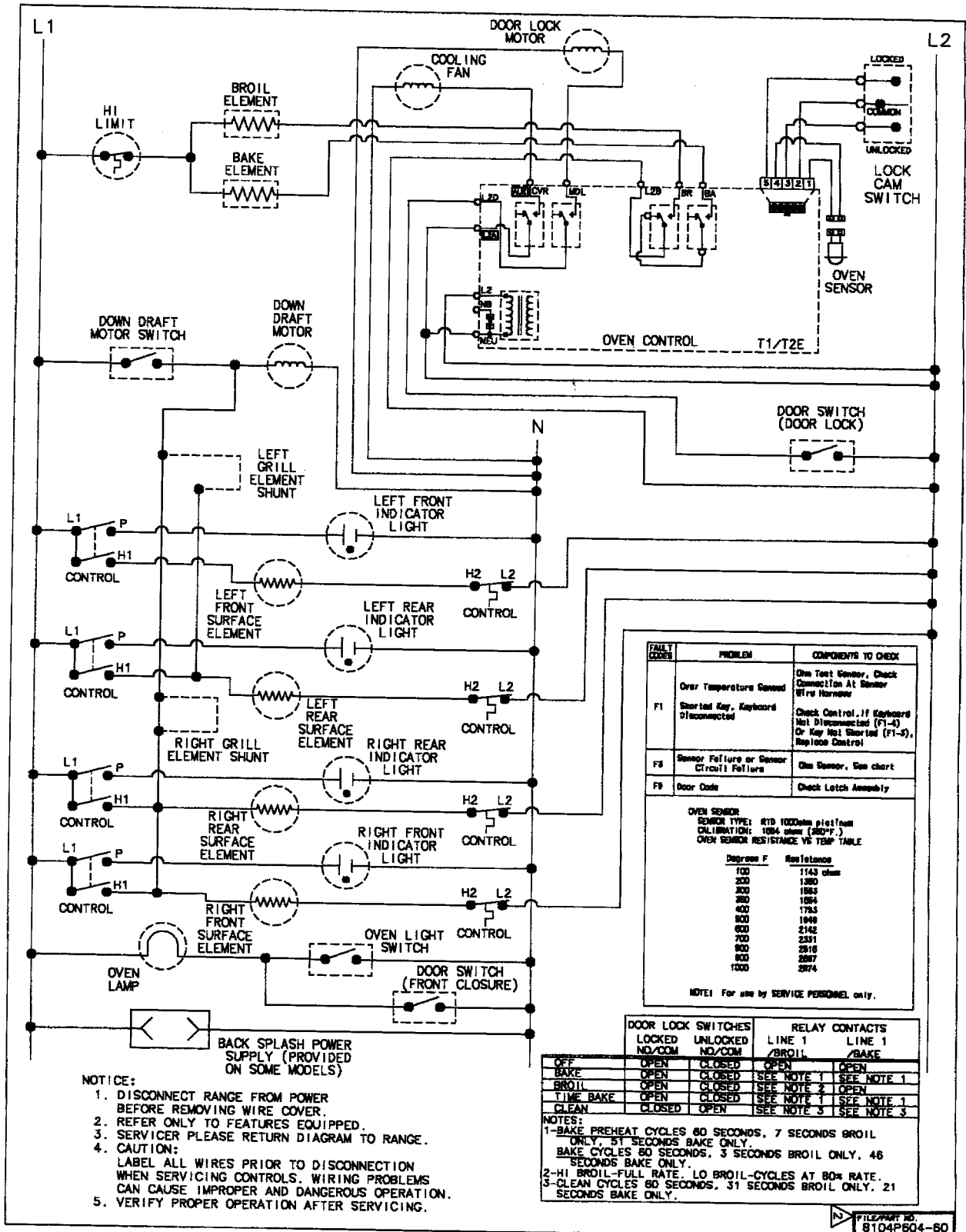

DIAGRAM NO.
8104P604-60

FILE# 8104P604-60

SVE47100 Schematic (Series 14)



SVE47500 Diagram

FAULT CODES	PROBLEM	COMPONENTS TO CHECK
F1	Power to element relay energized during time of day display.	J2 harness shorted, if checks ok, change (PRB) power relay board.
F2	Over temperature : over 488° sensed during time of day mode, bake mode, or over 399° sensed in clean mode.	One SENSOR. If checks ok, change power relay board. 'See chart for sensor value'
F3	Cooling fan on with no oven function selected.	One sensor, wire harness to sensor.
F4	Shorted oven sensor.	One sensor, wire harness to sensor.
F5	Power to element relays disabled in cook mode.	1) Intermittent sensor or wire harness connection. 2) Intermittent contact on PRB.
F7	Shorted key sensed for 32 seconds.	1) Membrane shorted. 2) Display board.
F8	Shorted seal probe alarm.	1) Probe jack or harness to probe jack. 2) Probe sensing temp. above 258°F. 'See chart'
F9	Door lock safety circuit on power relay board secured.	PRB.
FF	Invalid temp. reading on PRB.	PRB.
F-	Communication error between boards.	1) J2 Harness, ohm wires end to end. Harness ok, replace display board.
FC	Communication error between boards.	J2 harness, ok, replace PRB.
Double oven only		
FR	Second oven error sensed	1) Check sensor and harness. 2) Replace second oven board.

HEAT PROBE		OVEN SENSOR	
TYPE:	NTC thermistor	SENSOR TYPE:	RTD 1888ohm platinum
CALIBRATION:	9938 ohms (158°F.)	CALIBRATION:	1654 ohms (358°F.)
PROBE RESISTANCE VS TEMP TABLE		OVEN SENSOR RESISTANCE VS TEMP TABLE	
Decreases ↑	Resistance	Decreases ↑	Resistance
177	18943	188	1143
180	8838	190	5265
183	4838	192	2925
186	2846	194	1624
189	1654	196	924
192	954	198	524
195	564	200	324
198	374	202	224
201	284	204	174
204	204	206	134
207	154	208	104
210	114	210	84
213	84	212	64
216	64	214	54
219	54	216	44
222	44	218	34
225	34	220	24
228	24	222	14
231	14	224	10
234	10	226	7
237	7	228	5
240	5	230	4
243	4	232	3
246	3	234	2
249	2	236	1
252	1	238	1
255	1	240	1
258	1	242	1
261	1	244	1
264	1	246	1
267	1	248	1
270	1	250	1
273	1	252	1
276	1	254	1
279	1	256	1
282	1	258	1
285	1	260	1
288	1	262	1
291	1	264	1
294	1	266	1
297	1	268	1
300	1	270	1
303	1	272	1
306	1	274	1

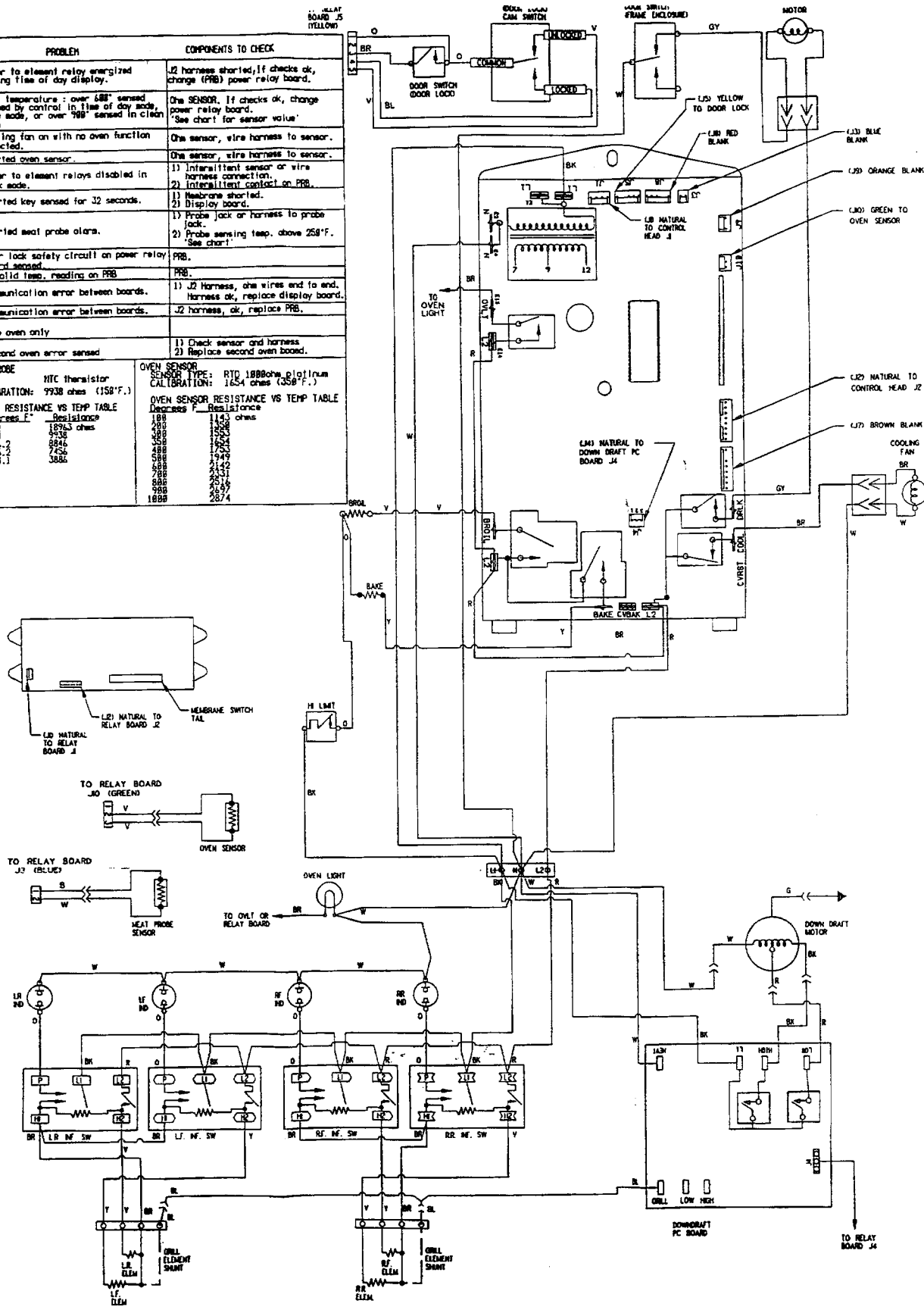

SVE47500 Schematic

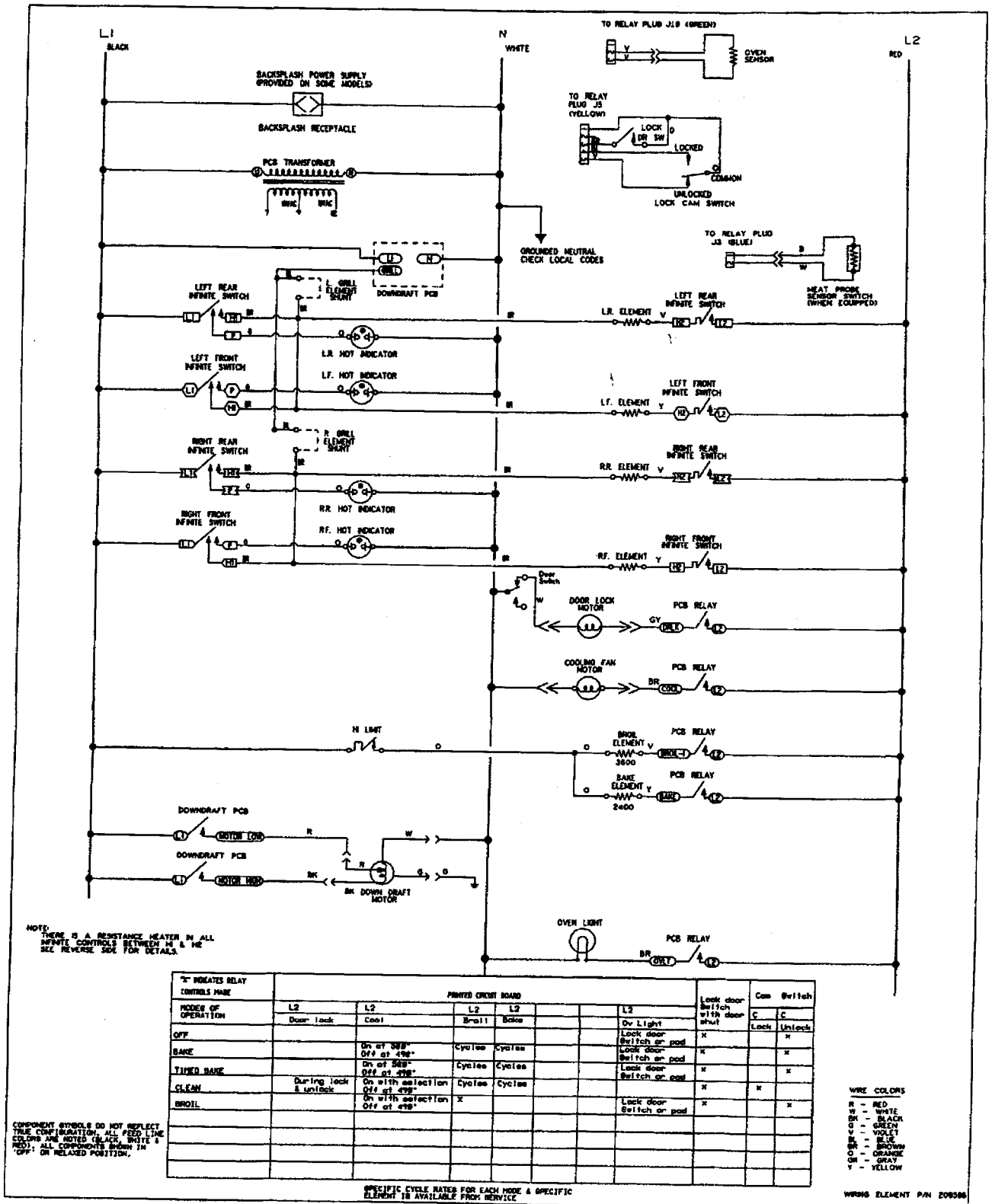

SIDE NO. 2

SVE47600 Diagram

FAULT CODES	PROBLEM	COMPONENTS TO CHECK
F1	Power to element relay energized during time of day display.	J2 harness shorted, J1 checks ok, change (PRB) power relay board.
F2	Over temperature, over 688° sensed by control in time of day mode, bake mode, or over 980° sensed in clean mode.	Oven sensor. If checks ok, change power relay board. See chart for sensor value.
F3	Cooling fan on with no oven function selected.	Oven sensor, wire harness to sensor.
F4	Shorted oven sensor.	Oven sensor, wire harness to sensor.
F5	Power to element relays disabled in cook mode.	1) Interim Heat sensor or wire harness connection. 2) Interim Heat contact on PRB.
F7	Shorted key sensed for > 32 seconds.	1) Membrane shorted. 2) Display board.
F8	Shorted heat probe alarm.	1) Probe lock of harness to probe lock. 2) Probe sensing temp. above 250°F. See chart.
F9	Door lock safety circuit on power relay board sensed.	PRB.
FF	Invalid temp. reading on PRB.	PRB.
F	Communication error between boards.	1) J2 Harness, ohm wires end to end. Harness ok, replace display board.
FC	Communication error between boards.	J2 harness, ok, replace PRB.
Double oven only		
FR	Second oven error sensed	1) Check sensor and harness. 2) Replace second oven board.

HEAT PROBE		OVEN SENSOR	
TYPE:	NTC thermistor	SENSOR TYPE:	RTD 100ohm platinum
CALIBRATION:	9938 ohms (150°F.)	CALIBRATION:	1654 ohms (350°F.)
PROBE RESISTANCE VS TEMP TABLE		OVEN SENSOR RESISTANCE VS TEMP TABLE	
Temperature F.	Resistance	Temperature F.	Resistance
120	12363 ohms	100	1145 ohms
150	9319	150	652
180	6546	200	400
210	4752	250	287
240	3526	300	212
270	2722	350	155
300	2156	400	112
330	1686	450	80
360	1306	500	58
390	999	550	43
420	756	600	32
450	568	650	24
480	426	700	18
510	318	750	13
540	236	800	10
570	176	850	7
600	132	900	5
630	100	950	4
660	75	1000	3
690	57		
720	43		
750	32		
780	24		
810	18		
840	13		
870	10		
900	7		
930	5		
960	4		
990	3		
1020	2		

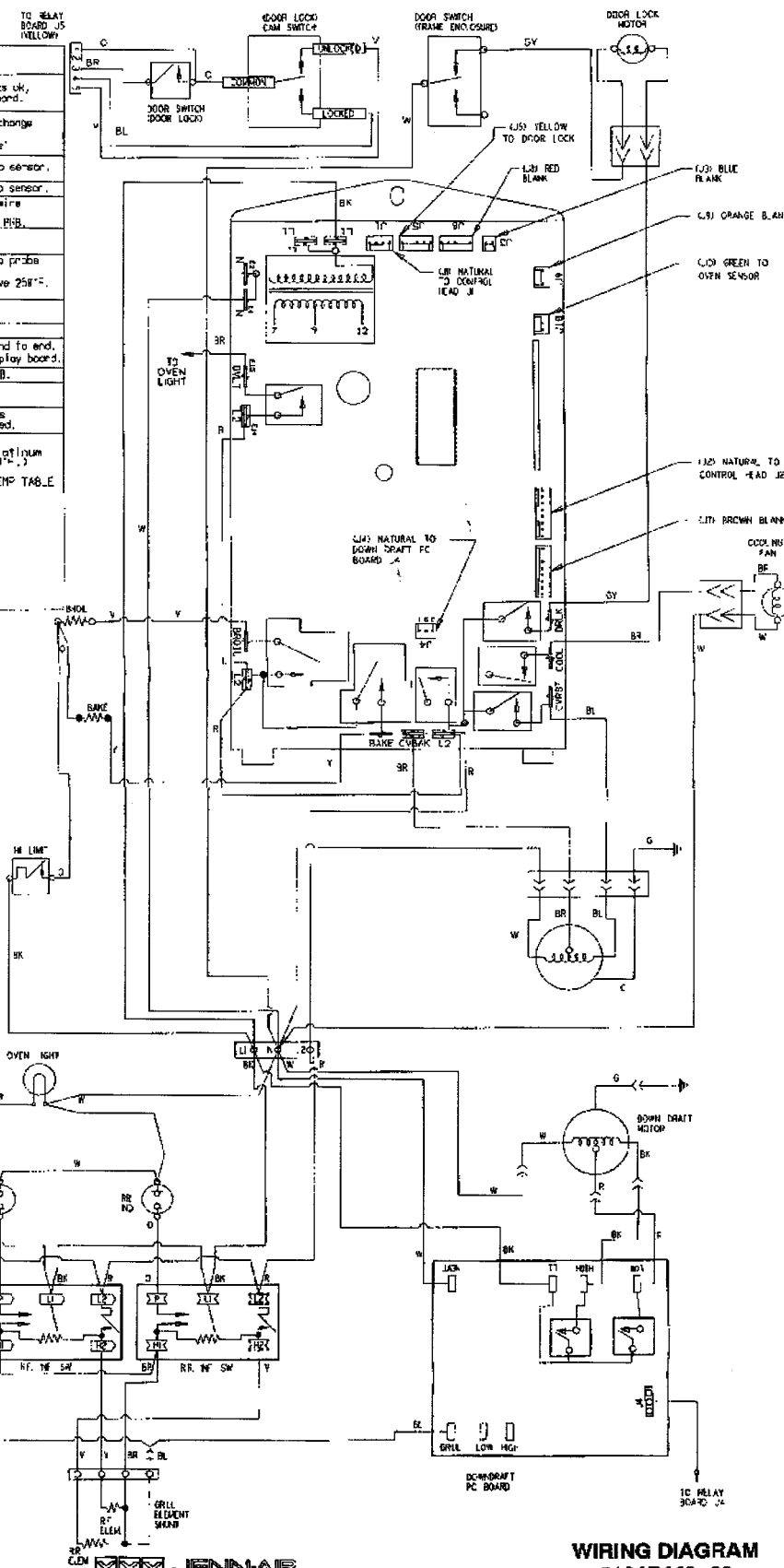
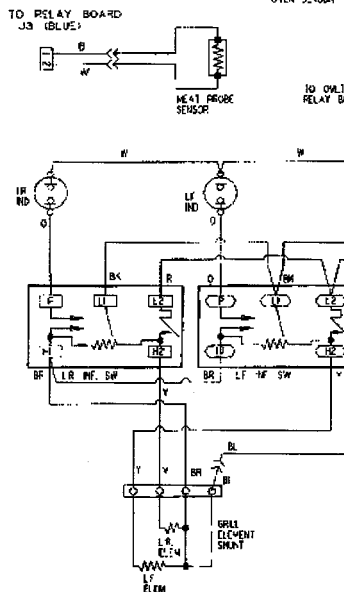
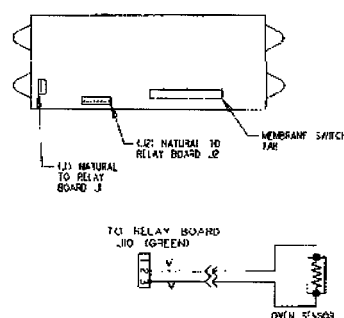

SVE47600 Schematic

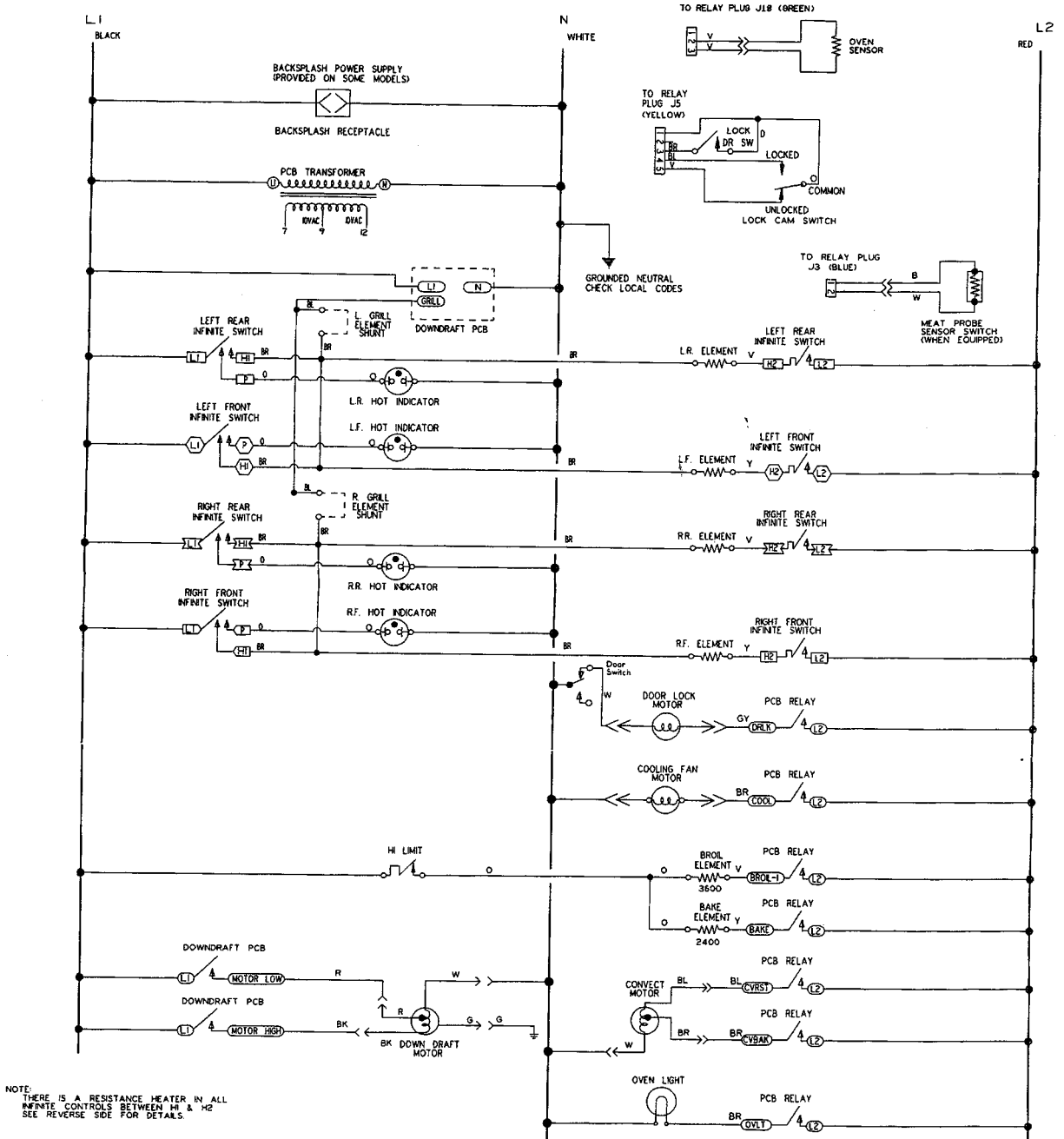

NOTE:
THERE IS A RESISTANCE HEATER IN ALL INFINITE CONTROLS BETWEEN HI & H2. SEE REVERSE SIDE FOR DETAILS.

COMPONENT SYMBOLS DO NOT REFLECT TRUE CONFIGURATION. ALL FEED LINE COLORS ARE NOTED (BLACK, WHITE & RED). ALL COMPONENTS SHOWN IN "OFF" OR RELAXED POSITION.

MODES OF OPERATION	PRINTED CIRCUIT BOARD								Lock door Switch with door shut	Cam Switch	
	L2	L2	L2	L2	L2	L2	L2	L2		C	C
OFF	Door Lock	Cool	Broil	Bake	Cv Bake	Cv Roast	Ov Light	Lock door Switch or pad	x		x
BAKE		On at 588° Off at 498°	Cycles	Cycles			Lock door Switch or pad	x		x	
TIMED BAKE		On at 588° Off at 498°	Cycles	Cycles			Lock door Switch or pad	x		x	
CONVECT BAKE		On at 588° Off at 498°	Cycles	Cycles	X Door Closed		Lock door Switch or pad	x		x	
TIMED CONVECT BAKE		On at 588° Off at 498°	Cycles	Cycles	X Door Closed		Lock door Switch or pad	x		x	
CONVECT ROAST		On at 588° Off at 498°	Cycles	Cycles		X Door Closed	Lock door Switch or pad	x		x	
TIMED CONVECT ROAST		On at 588° Off at 498°	Cycles	Cycles		X Door Closed	Lock door Switch or pad	x		x	
CLEAN	During lock & unlock	On with selection Off at 498°	Cycles	Cycles			Lock door Switch or pad	x	x	x	
BROIL		On with selection Off at 498°	X				Lock door Switch or pad	x		x	

SPECIFIC CYCLE RATES FOR EACH MODE & SPECIFIC ELEMENT IS AVAILABLE FROM SERVICE

WIRING DIAGRAM 8104P449-60

WIRING DIAGRAM 8104P449-60

- WIRE COLORS
- R - RED
 - W - WHITE
 - BL - BLACK
 - G - GREEN
 - V - VIOLET
 - BL - BLUE
 - BR - BROWN
 - O - ORANGE
 - GR - GRAY
 - Y - YELLOW

WIRING ELEMENT P/N 207649

SVE47600*C Diagram

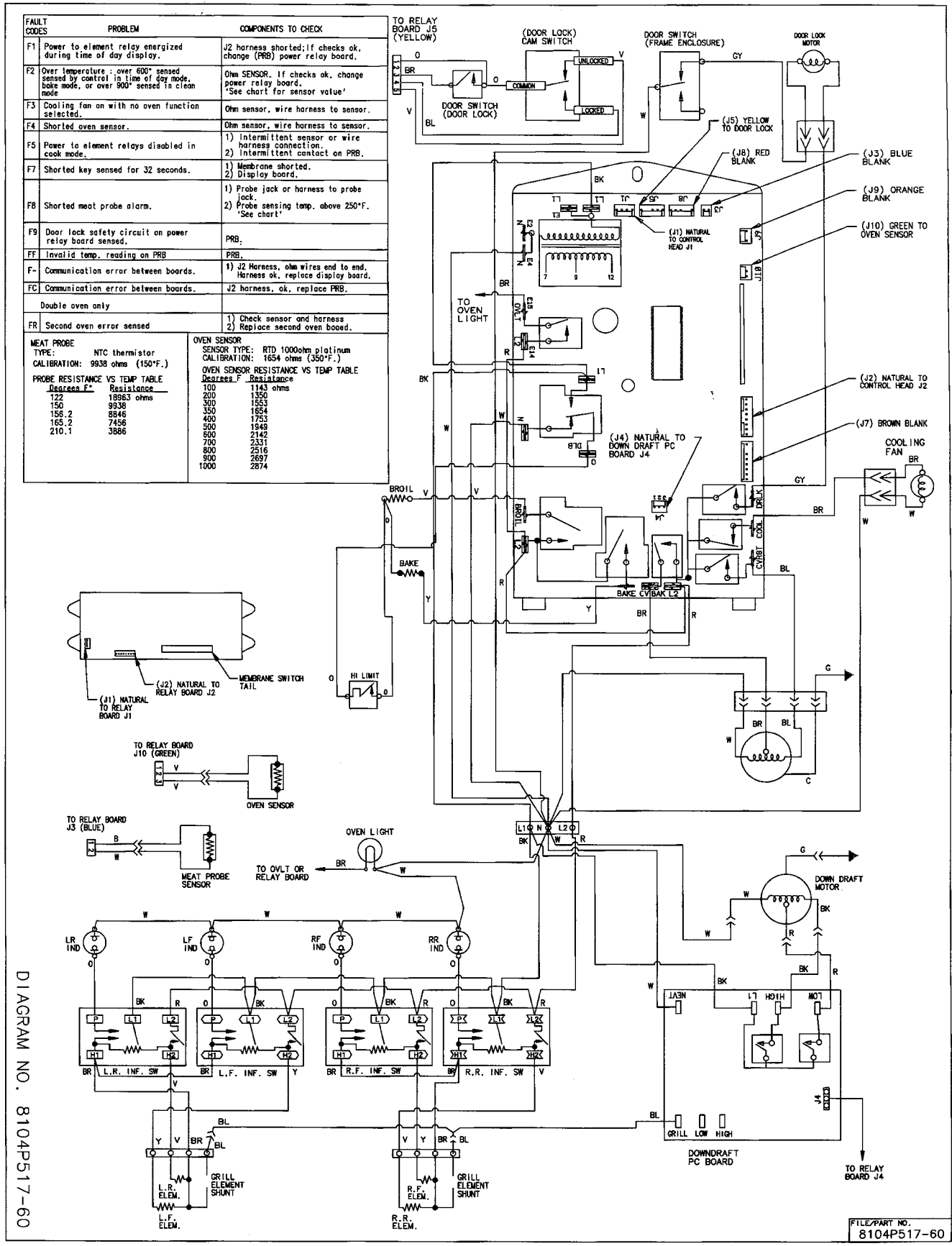
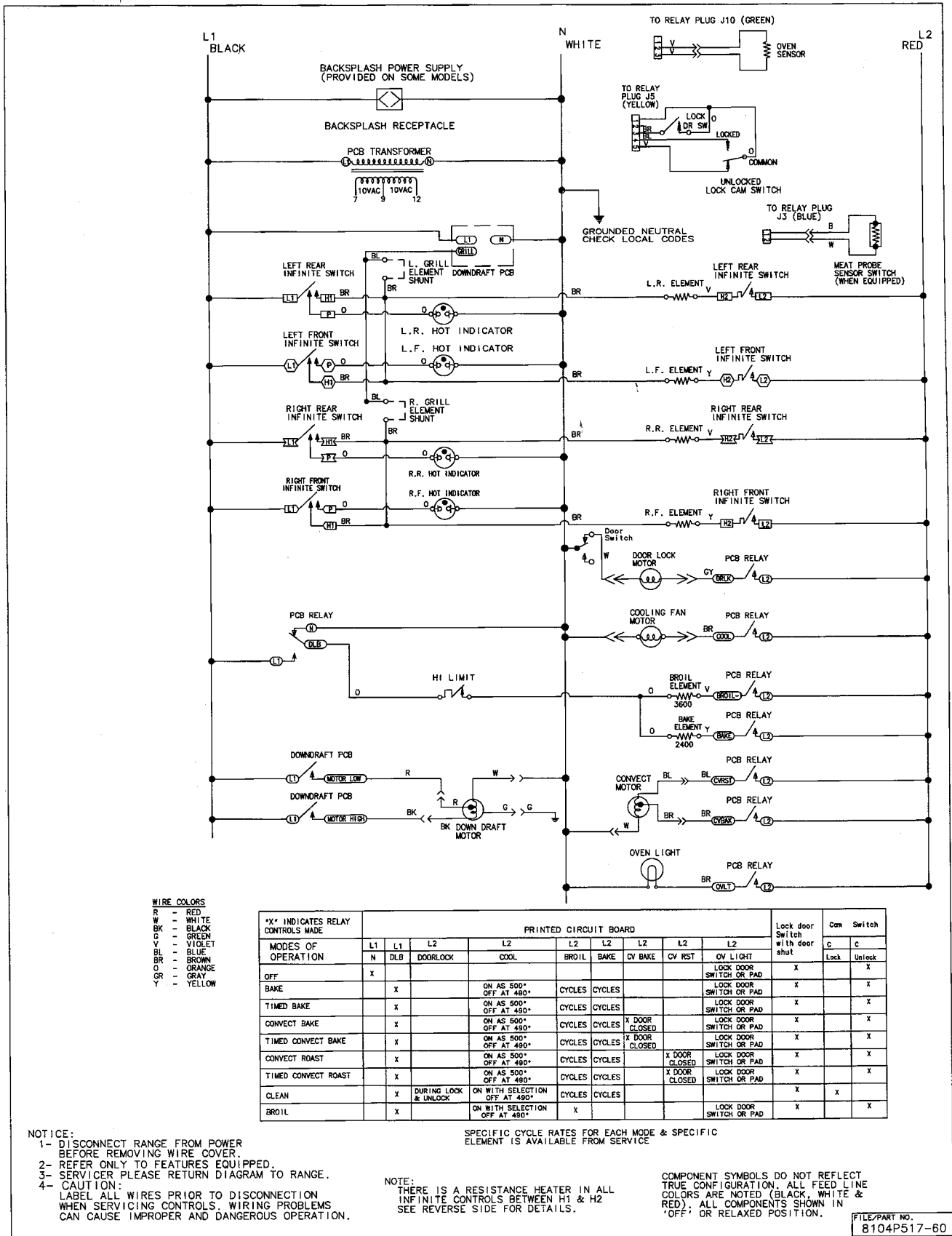

DIAGRAM NO. 8104P517-60

FILE/PART NO. 8104P517-60

SVE47600*C Schematic



SVE87600 Diagram

FAULT CODES	PROBLEM	COMPONENTS TO CHECK																																							
F1	Power to element relay energized during time of day display.	J2 harness shorted: If checks ok, change (PRB) power relay board.																																							
F2	Over temperature: over 600° sensed by control in time of day mode, bake mode, or over 900° sensed in clean mode.	Ohm SENSOR. If checks ok, change power relay board. *See chart for sensor value*																																							
F3	Cooling fan on with no oven function selected.	Ohm sensor, wire harness to sensor.																																							
F4	Shorted oven sensor.	Ohm sensor, wire harness to sensor.																																							
F6	Power to element relays disabled in cook mode.	1) Intermittent sensor or wire harness connection. 2) Intermittent contact on PRB.																																							
F7	Shorted key sensed for 32 seconds.	1) Membrane shorted. 2) Display board.																																							
FB	Shorted meat probe alarm.	1) Probs jack or harness to probe jack. 2) Probe sensing temp. above 260°F. *See chart*																																							
FD	Door lock safety circuit on power relay board sensed.	PRB.																																							
FF	Invalid temp. reading on PRB	PRB.																																							
FC	Communication error between boards.	1) J2 Harness, ohm wires end to end. Harness ok, replace display board.																																							
FE	Communication error between boards.	J2 harness, ok, replace PRB.																																							
Double oven only																																									
FR	Second oven error sensed	1) Check sensor and harness 2) Replace second oven board.																																							
<table border="0" style="width: 100%;"> <tr> <td style="width: 33%;"> MEAT PROBE TYPE: NTC thermistor CALIBRATION: 9938 ohms (150°F.) PROBE RESISTANCE VS TEMP TABLE <table border="1" style="font-size: small;"> <thead> <tr> <th>Degree F</th> <th>Resistance</th> </tr> </thead> <tbody> <tr><td>122</td><td>18953 ohms</td></tr> <tr><td>150</td><td>9938</td></tr> <tr><td>156.2</td><td>8848</td></tr> <tr><td>165.2</td><td>7455</td></tr> <tr><td>210.1</td><td>3886</td></tr> </tbody> </table> </td> <td style="width: 33%;"> OVEN SENSOR SENSOR TYPE: RTD 1000ohm platinum CALIBRATION: 1884 ohms (350°F.) OVEN SENSOR RESISTANCE VS TEMP TABLE <table border="1" style="font-size: small;"> <thead> <tr> <th>Degree F</th> <th>Resistance</th> </tr> </thead> <tbody> <tr><td>100</td><td>1143 ohms</td></tr> <tr><td>200</td><td>1350</td></tr> <tr><td>300</td><td>1553</td></tr> <tr><td>350</td><td>1654</td></tr> <tr><td>400</td><td>1753</td></tr> <tr><td>500</td><td>1949</td></tr> <tr><td>600</td><td>2142</td></tr> <tr><td>700</td><td>2331</td></tr> <tr><td>800</td><td>2516</td></tr> <tr><td>900</td><td>2697</td></tr> <tr><td>1000</td><td>2874</td></tr> </tbody> </table> </td> <td style="width: 33%;"></td> </tr> </table>			MEAT PROBE TYPE: NTC thermistor CALIBRATION: 9938 ohms (150°F.) PROBE RESISTANCE VS TEMP TABLE <table border="1" style="font-size: small;"> <thead> <tr> <th>Degree F</th> <th>Resistance</th> </tr> </thead> <tbody> <tr><td>122</td><td>18953 ohms</td></tr> <tr><td>150</td><td>9938</td></tr> <tr><td>156.2</td><td>8848</td></tr> <tr><td>165.2</td><td>7455</td></tr> <tr><td>210.1</td><td>3886</td></tr> </tbody> </table>	Degree F	Resistance	122	18953 ohms	150	9938	156.2	8848	165.2	7455	210.1	3886	OVEN SENSOR SENSOR TYPE: RTD 1000ohm platinum CALIBRATION: 1884 ohms (350°F.) OVEN SENSOR RESISTANCE VS TEMP TABLE <table border="1" style="font-size: small;"> <thead> <tr> <th>Degree F</th> <th>Resistance</th> </tr> </thead> <tbody> <tr><td>100</td><td>1143 ohms</td></tr> <tr><td>200</td><td>1350</td></tr> <tr><td>300</td><td>1553</td></tr> <tr><td>350</td><td>1654</td></tr> <tr><td>400</td><td>1753</td></tr> <tr><td>500</td><td>1949</td></tr> <tr><td>600</td><td>2142</td></tr> <tr><td>700</td><td>2331</td></tr> <tr><td>800</td><td>2516</td></tr> <tr><td>900</td><td>2697</td></tr> <tr><td>1000</td><td>2874</td></tr> </tbody> </table>	Degree F	Resistance	100	1143 ohms	200	1350	300	1553	350	1654	400	1753	500	1949	600	2142	700	2331	800	2516	900	2697	1000	2874	
MEAT PROBE TYPE: NTC thermistor CALIBRATION: 9938 ohms (150°F.) PROBE RESISTANCE VS TEMP TABLE <table border="1" style="font-size: small;"> <thead> <tr> <th>Degree F</th> <th>Resistance</th> </tr> </thead> <tbody> <tr><td>122</td><td>18953 ohms</td></tr> <tr><td>150</td><td>9938</td></tr> <tr><td>156.2</td><td>8848</td></tr> <tr><td>165.2</td><td>7455</td></tr> <tr><td>210.1</td><td>3886</td></tr> </tbody> </table>	Degree F	Resistance	122	18953 ohms	150	9938	156.2	8848	165.2	7455	210.1	3886	OVEN SENSOR SENSOR TYPE: RTD 1000ohm platinum CALIBRATION: 1884 ohms (350°F.) OVEN SENSOR RESISTANCE VS TEMP TABLE <table border="1" style="font-size: small;"> <thead> <tr> <th>Degree F</th> <th>Resistance</th> </tr> </thead> <tbody> <tr><td>100</td><td>1143 ohms</td></tr> <tr><td>200</td><td>1350</td></tr> <tr><td>300</td><td>1553</td></tr> <tr><td>350</td><td>1654</td></tr> <tr><td>400</td><td>1753</td></tr> <tr><td>500</td><td>1949</td></tr> <tr><td>600</td><td>2142</td></tr> <tr><td>700</td><td>2331</td></tr> <tr><td>800</td><td>2516</td></tr> <tr><td>900</td><td>2697</td></tr> <tr><td>1000</td><td>2874</td></tr> </tbody> </table>	Degree F	Resistance	100	1143 ohms	200	1350	300	1553	350	1654	400	1753	500	1949	600	2142	700	2331	800	2516	900	2697	1000	2874				
Degree F	Resistance																																								
122	18953 ohms																																								
150	9938																																								
156.2	8848																																								
165.2	7455																																								
210.1	3886																																								
Degree F	Resistance																																								
100	1143 ohms																																								
200	1350																																								
300	1553																																								
350	1654																																								
400	1753																																								
500	1949																																								
600	2142																																								
700	2331																																								
800	2516																																								
900	2697																																								
1000	2874																																								

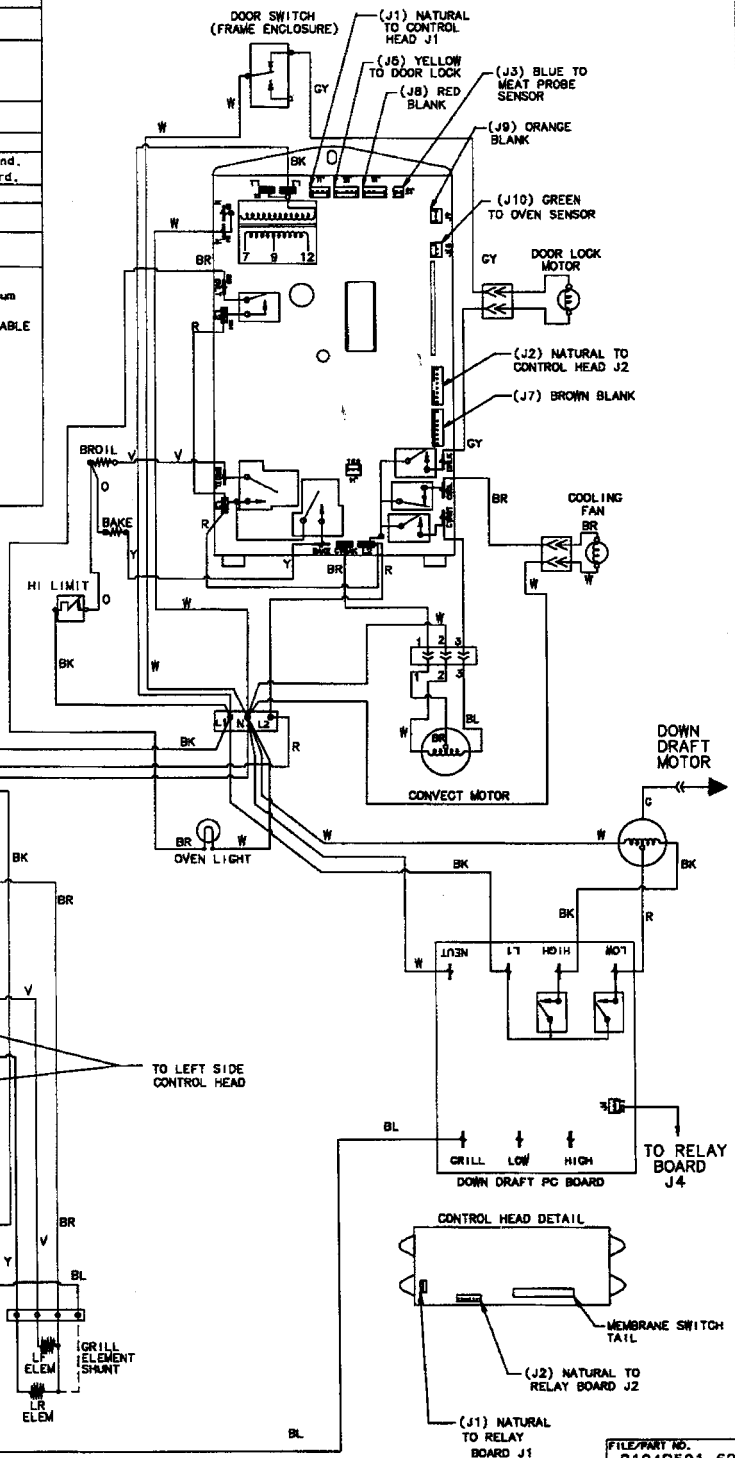
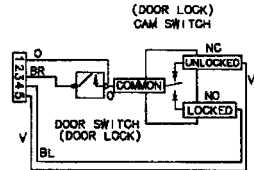
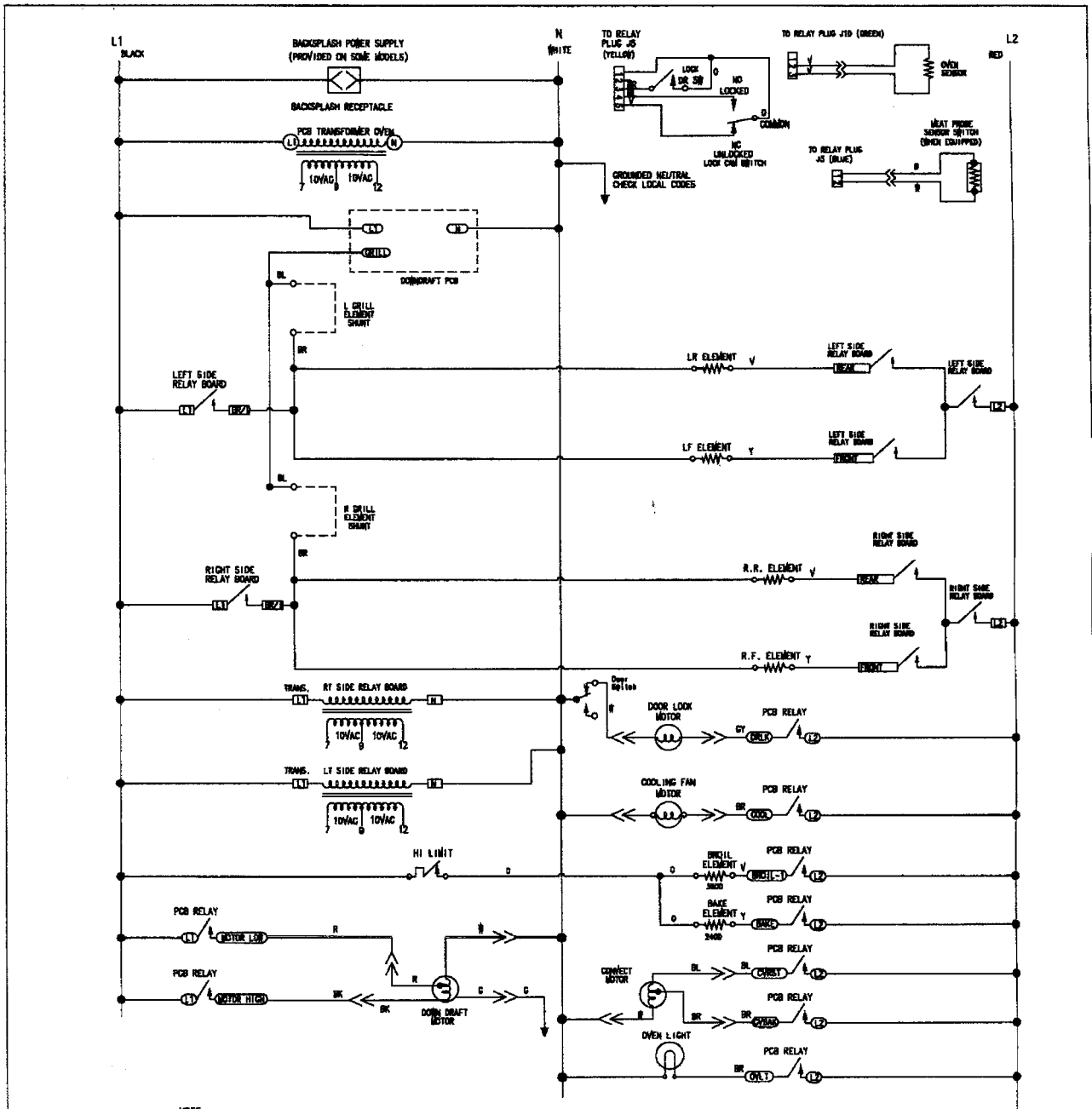

DIAGRAM NO. 8104P521-60

FILE/PART NO. 8104P521-60

SVE87600 Schematic



WIRE COLORS
 R - RED
 W - WHITE
 BK - BLACK
 G - GREEN
 V - VIOLET
 BL - BLUE
 BR - BROWN
 O - ORANGE
 GR - GRAY
 Y - YELLOW

NOTE:
 THERE IS A RESISTANCE HEATER IN ALL INFINITE CONTROLS BETWEEN H1 & H2, OR, N & 4 & 2 SEE REVERSE SIDE FOR DETAILS.

- NOTICE:**
1. DISCONNECT RANGE FROM POWER BEFORE REMOVING WIRE COVER.
 2. REFER ONLY TO FEATURES EQUIPPED.
 3. SERVICER PLEASE RETURN DIAGRAM TO RANGE.
 4. CAUTION: LABEL ALL WIRES PRIOR TO DISCONNECTION WHEN SERVICING CONTROLS. WIRING PROBLEMS CAN CAUSE IMPROPER AND DANGEROUS OPERATION.

COMPONENT SYMBOLS DO NOT REFLECT TRUE CONFIGURATION. ALL FEED LINE COLORS ARE NOTED (BLACK, WHITE & RED). ALL COMPONENTS SHOWN IN 'OFF' OR RELAXED POSITION.

SPECIFIC CYCLE RATES FOR EACH MODE & SPECIFIC ELEMENT IS AVAILABLE FROM SERVICE

MODES OF OPERATION	L2							Look door switch if in door shut	Cov	
	Door lock	Cool	Braill	Bake	Cy Bake	Cy Ro1	Dv Light		E	C
BAKE		On at 500° Off at 400°	Cycles	Cycles				Look door Switch or pad	x	x
TIMED BAKE		On at 500° Off at 400°	Cycles	Cycles				Look door Switch or pad	x	x
CONNECT BAKE		On at 500° Off at 400°	Cycles	Cycles	X Door Closed			Look door Switch or pad	x	x
TIMED CONNECT BAKE		On at 500° Off at 400°	Cycles	Cycles	X Door Closed			Look door Switch or pad	x	x
CONNECT ROAST		On at 500° Off at 400°	Cycles	Cycles	X Door Closed			Look door Switch or pad	x	x
TIMED CONNECT ROAST		On at 500° Off at 400°	Cycles	Cycles	X Door Closed			Look door Switch or pad	x	x
CLEAN	During touch & release	On at 500° Off at 400°	Cycles	Cycles				Look door Switch or pad	x	x
BROIL		On with selection Off at 400°	X	Cycles				Look door Switch or pad	x	x

FILE/PART NO. 810-4P621-60



MAYTAG

Maytag Appliances Sales Company

Customer Service
240 Edwards St.
Cleveland, TN 37311