

SERVICE NOTEBOOK

**VDSC367 DUAL FUEL SELFCLEAN
FREESTANDING RANGES /
SEALED BURNERS**

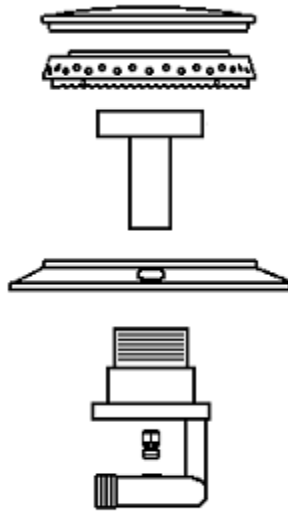

VIKING RANGE CORPORATION ®



BURNER ASSEMBLY

VIKING RANGE CORPORATION, P. O. DRAWER 956, GREENWOOD, MS.38930 USA

TABLE OF CONTENTS

<p>TABLE OF CONTENTS----- 2</p> <p>Customer information----- 3</p> <p>Model / Serial Number Logic----- 4</p> <p>Warranty Statement----- 5</p> <p>Proximity to Side Cabinets ----- 6/7</p> <p>Anti-Tip Device----- 8</p> <p>Range Leveling----- 9</p> <p>Wood Overlay (Hood)----- 10</p> <p>COMPONENTS/COLOR CODED WIRES</p> <p>Component Description----- 11/16</p> <p>P.C. Timer Board Voltage Readings----- 17</p> <p>8-Position Selector Switch----- 18</p> <p>Oven Calibration----- 19</p> <p>Heating Elements Description----- 20</p> <p style="text-align: center;">VDSC367 Disassemble</p> <p>Rear Component Location----- 21</p> <p>Range Top----- 22</p> <p>Griddle Assembly----- 23</p> <p>Control Panel (Serial / Tech Sheets)----- 24</p> <p>Griddle Removal----- 25</p> <p>Burner / Burner Support----- 26</p> <p>Griddle Gas Valve----- 27</p> <p>Griddle Valve and Igniter Circuit----- 28</p> <p>Igniter System----- 29</p> <p>Door Lock Motor----- 30</p>	<p>Gas Combustion----- 31</p> <p>Gas Connections----- 32/33</p> <p>L.P. Conversion----- 34</p> <p>Electrical Connections----- 35/36</p> <p>Service Burner Spark Module----- 37</p> <p>Pre-Heat PC Board----- 38</p> <p>Component Contacts (VDSC367)----- 39</p> <p>Wiring Diagram (VDSC367)----- 40</p> <p>Wiring Diagram Surface Burner Module----- 41</p> <p>Wiring Diagram Dual Fuel 48”----- 42</p> <p>Component Contacts Dual Fuel 48”----- 43</p> <p>BREAK OUT WIRING DIAGRAMS</p> <p>Bake----- 44</p> <p>Convection Bake----- 45</p> <p>Convection Cook----- 46</p> <p>Broil----- 47</p> <p>Maxi-Broil----- 48</p> <p>Convection Broil----- 49</p> <p>Self-Clean----- 50</p> <p>Self-Clean (Left Hand Oven—48”)----- 51</p> <p>Troubleshooting Guide----- 52/54</p> <p>VDSC “ Locked” Door----- 55</p> <p>Griddle Assembly----- 56</p> <p>Grill Assembly----- 57</p>
---	--

GENERAL INFORMATION

1. **WARNING:** The use of cabinets for storage above the appliance may result in a potential burn hazard. Combustible items may ignite, metallic items may become hot and cause burns. If a cabinet storage is to be provided the risk can be reduced by installing a rangehood that projects horizontally a minimum of 5" beyond the bottom of the cabinets.
2. **WARNING:** This appliance shall not be used for space heating. This information is based on safety considerations.
3. When removing the oven for cleaning of servicing;
 - A) Shut off gas at main supply
 - B) Disconnect AC power supply,
 - C) Disconnect gas line to the inlet pipe.
 - D) Carefully remove the range by pulling outward. **CAUTION:** Range is heavy; use care in handling

WARNING: ELECTRICAL GROUNDING INSTRUCTIONS

This appliance must be electrically grounded in accordance with local codes or, in the absence of codes, with the National Electrical Code, ANSI/NFPA 70 – latest edition.

FOR PERSONAL SAFETY, THIS APPLIANCE MUST BE PROPERLY GROUNDED.

IMPORTANT INFORMATION

The information contained in this manual is intended for use by a qualified service technician who is familiar with the application of all safety procedures required in the repair of any gas or electric appliance, and who is equipped with the proper tools and testing instruments.

Repairs covered in this manual and made by unqualified persons can result in hazards developing due to improper assembly or adjustment.

Inexperienced persons making such repairs subject themselves to the risk of injury or electrical shock which can be serious or even fatal.

IMPORTANT NOTE TO CUSTOMER

If you perform service on your own Viking product, you must assume responsibility of personal injury or property damage which may result.

Viking will not be responsible for injury or property damage arising from service performed by other than Viking Factory Authorized Service Agencies.

In order to locate a Viking Factory Authorized Service Agency, please consult the dealer from whom you purchased this product. You may also write to:

Viking Preferred Service
P.O. Drawer 956
Greenwood, Ms. 38930

VIKING MODEL NUMBERS

RANGES AND RANGETOPS

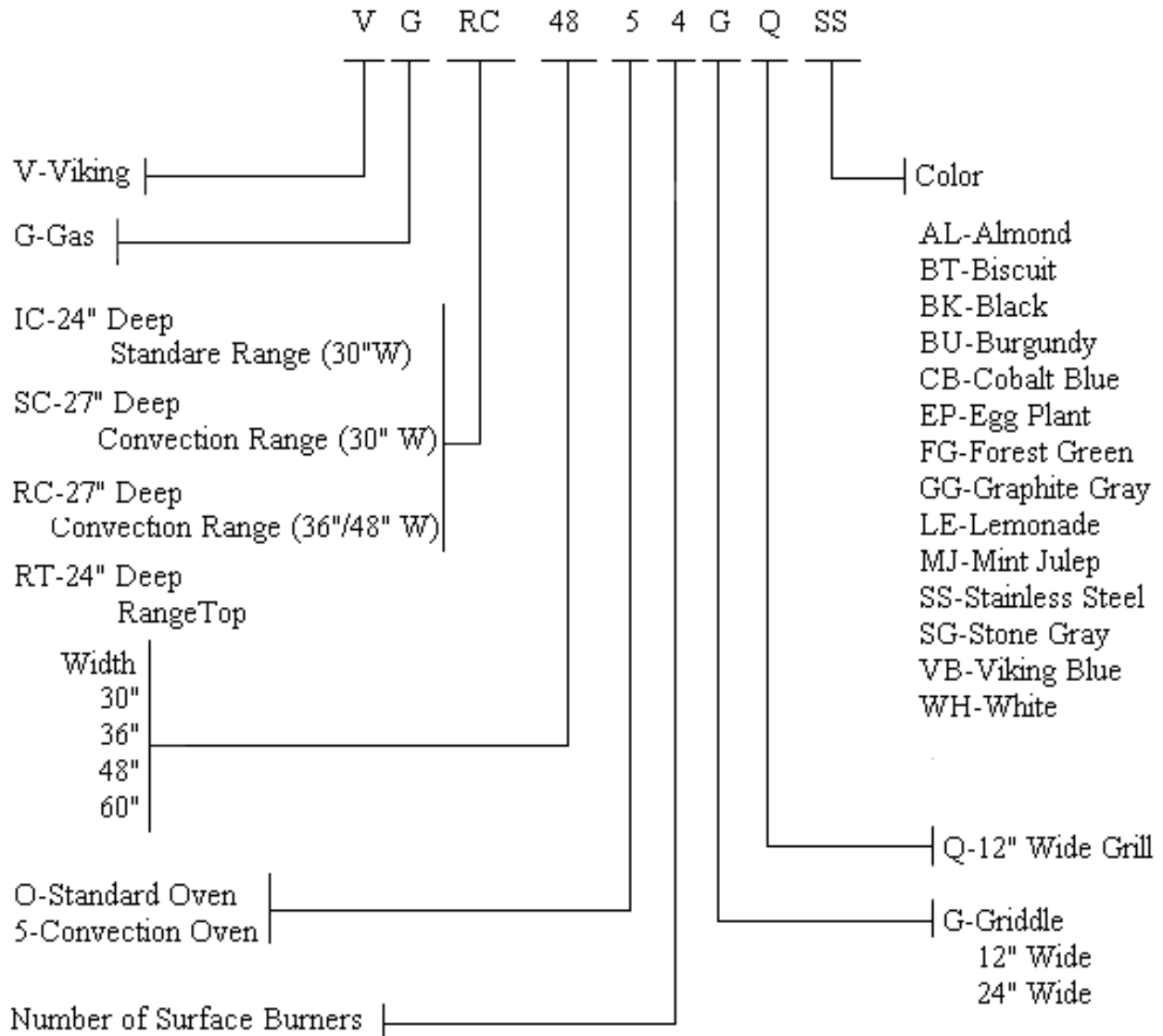

Serial Number 0303G000000163

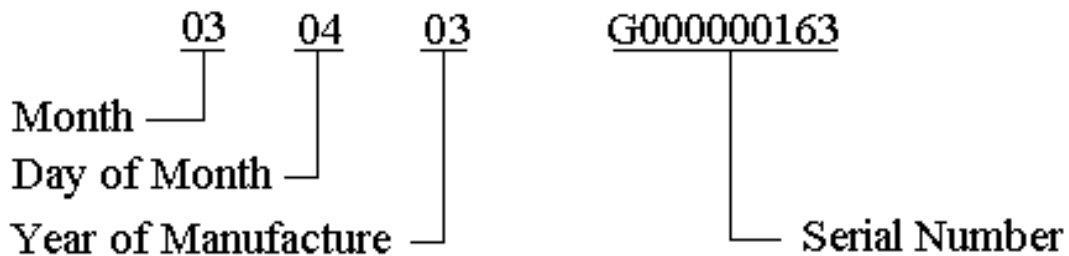

PROFESSIONAL SERIES FREESTANDING DUAL FUEL RANGES WARRANTY

ONE YEAR FULL WARRANTY

Freestanding dual fuel ranges and all of their component parts and accessories, except as detailed below, are warranted to be free from defective materials or workmanship in normal household use for a period of twelve (12) months from the date of original retail purchase. Viking Range Corporation, warrantor, agrees to repair or replace, at its option, any part which fails or is found to be defective during the warranty period.

*Glass (including light bulbs), painted and decorative items are warranted to be free from defective materials or workmanship for a period of ninety (90) days from the date of original retail purchase. ANY DEFECTS MUST BE REPORTED TO THE SELLING DEALER WITHIN NINETY (90) DAYS FROM DATE OF ORIGINAL RETAIL PURCHASE.

FIVE YEAR LIMITED WARRANTY

Any surface burner, griddle burner, grill burner, bake element, broil element, or convection cook element which fails due to defective materials or workmanship in normal household use during the second through fifth year from the date of original retail purchase will be repaired or replaced, free of charge for the part itself, with the owner paying all other costs, including labor.

TEN YEAR LIMITED WARRANTY

Any porcelain oven or porcelain inner door panel which rusts through due to defective materials or workmanship in normal household use during the second through the tenth year from the date of original retail purchase will be repaired or replaced, free of charge for the part itself, with the owner paying all other costs, including labor.

This warranty extends to the original purchaser of the product warranted hereunder and to each transferee owner of the product during the term of the warranty.

This warranty shall apply to products purchased and located in the United States and Canada. Products must be purchased in the country where service is requested. Warranty labor shall be performed by an authorized Viking Range Corporation service agency or representative. Warranty shall not apply to damage resulting from abuse, accident, natural disaster, loss of electrical power to the product for any reason, alteration, outdoor use, improper installation, improper operation, or repair or service of the product by anyone other than an authorized Viking Range Corporation service agency or representative. This warranty does not apply to commercial usage. Warrantor is not responsible for consequential or incidental damage whether arising out of breach of warranty, breach of contract, or otherwise. Some jurisdictions do not allow the exclusion or limitation of incidental or consequential damages, so the above limitation or exclusion may not apply to you.

Owner shall be responsible for proper installation, providing normal care and maintenance, providing proof of purchase upon request, and making the appliance reasonably accessible for service. If the product or one of its component parts contains a defect or malfunction during the warranty period, after a reasonable number of attempts by the warrantor to remedy the defects or malfunctions, the owner is entitled to either a refund or replacement of the product or its component part or parts. Warrantor's liability on any claim of any kind, with respect to the goods or services covered hereunder, shall in no case exceed the price of the goods or service or part thereof which gives rise to the claim.

WARRANTY SERVICE: Under the terms of this warranty, service must be performed by a factory authorized Viking Range Corporation service agent or representative. Service will be provided during normal business hours, and labor performed at overtime or premium rates shall not be covered by this warranty. To obtain warranty service, contact the dealer from whom the product was purchased, an authorized Viking Range Corporation service agent, or Viking Range Corporation. Provide model and serial number and date of original purchase. For the name of your nearest authorized Viking Range Corporation service agency, call the dealer from whom the product was purchased or Viking Range Corporation.

IMPORTANT: Retain proof of original purchase to establish warranty period.

The return of the Owner Registration Card is not a condition of warranty coverage. You should, however, return the Owner Registration Card so that Viking Range Corporation can contact you should any question of safety arise which could affect you.

Any implied warranties of merchantability and fitness applicable to the above described surface burner, griddle burner, grill burner, bake element, broil element, convection cook element, porcelain oven, or porcelain inner door panel are limited in duration to the period of coverage of the applicable express written limited warranties set forth above. Some jurisdictions do not allow limitations on how long an implied warranty lasts, so the above limitation may not apply to you. This warranty gives you specific legal rights, and you may also have other rights which may vary from jurisdiction to jurisdiction.

VIKING RANGE CORPORATION
111 Front Street
Greenwood, Mississippi (MS) 38930 USA • (662) 455-1200

PROXIMITY TO SIDE CABINET INSTALLATION

1. Range / Range tops may be installed directly adjacent to existing 36" high base cabinets. **IMPORTANT**-the top grate support **MUST** be 3/8" above the adjacent base cabinet countertop. This may be accomplished by raising the unit, (using the adjustment spindles on the range legs) or (using shims for the range top).
2. The range / range top **CANNOT** be installed directly adjacent to sidewalls, tall cabinets, tall appliances, or other side vertical surfaces above 36" high. There must be a minimum of 6" side clearance from the range to such combustible surfaces above the 36" counter height.
3. Within the 6" side clearance to combustible vertical surfaces above 36", the maximum wall cabinet depth must be 13" and wall cabinets within this 6" side clearance must be 18" above the 36" high countertop.
4. Wall cabinets above the range / range top must be a minimum of 36" above the cooking surface for the full width of the range / range top.

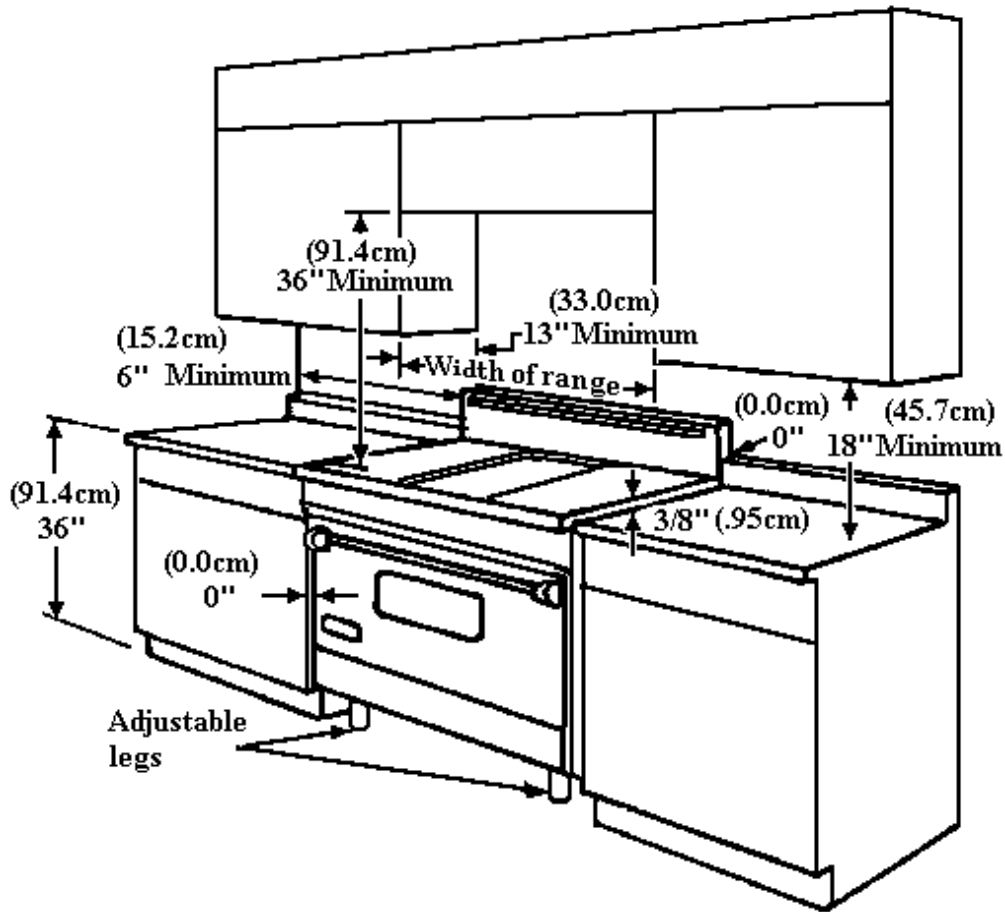

	30" W. Models	36" W. Models	48" W. Models
Overall Width	29 7/8" (75.9cm)	35 7/8" (91.1cm)	47 7/8" (121.6cm)

**PROXIMITY TO SIDE CABINET INSTALLATION
(24" W. MODELS)**

1. This range may be installed directly adjacent to existing 36" high base cabinets. **IMPORTANT:** The top grate support **MUST** be 3/8" above the adjacent base cabinet countertop. This may be accomplished by raising the unit using the adjustment spindles on the legs.
2. The range **CANNOT** be installed directly adjacent to sidewalls, tall cabinets, tall appliances, or other side vertical surfaces above 36" high. There must be a minimum of 6" side clearance for the 4-burner and Griddle model ranges and a minimum of 9" side clearance for the Char-Grill model to such combustible surfaces above the 36" counter height.
3. Within the side clearance to combustible vertical surfaces above 36", the maximum wall cabinet depth must be 13" and wall cabinets within this side clearance must be 18" above the 36" high countertop.
4. Wall cabinets above the range must be a minimum of 42" above the range cooking surface for the full width of the range.

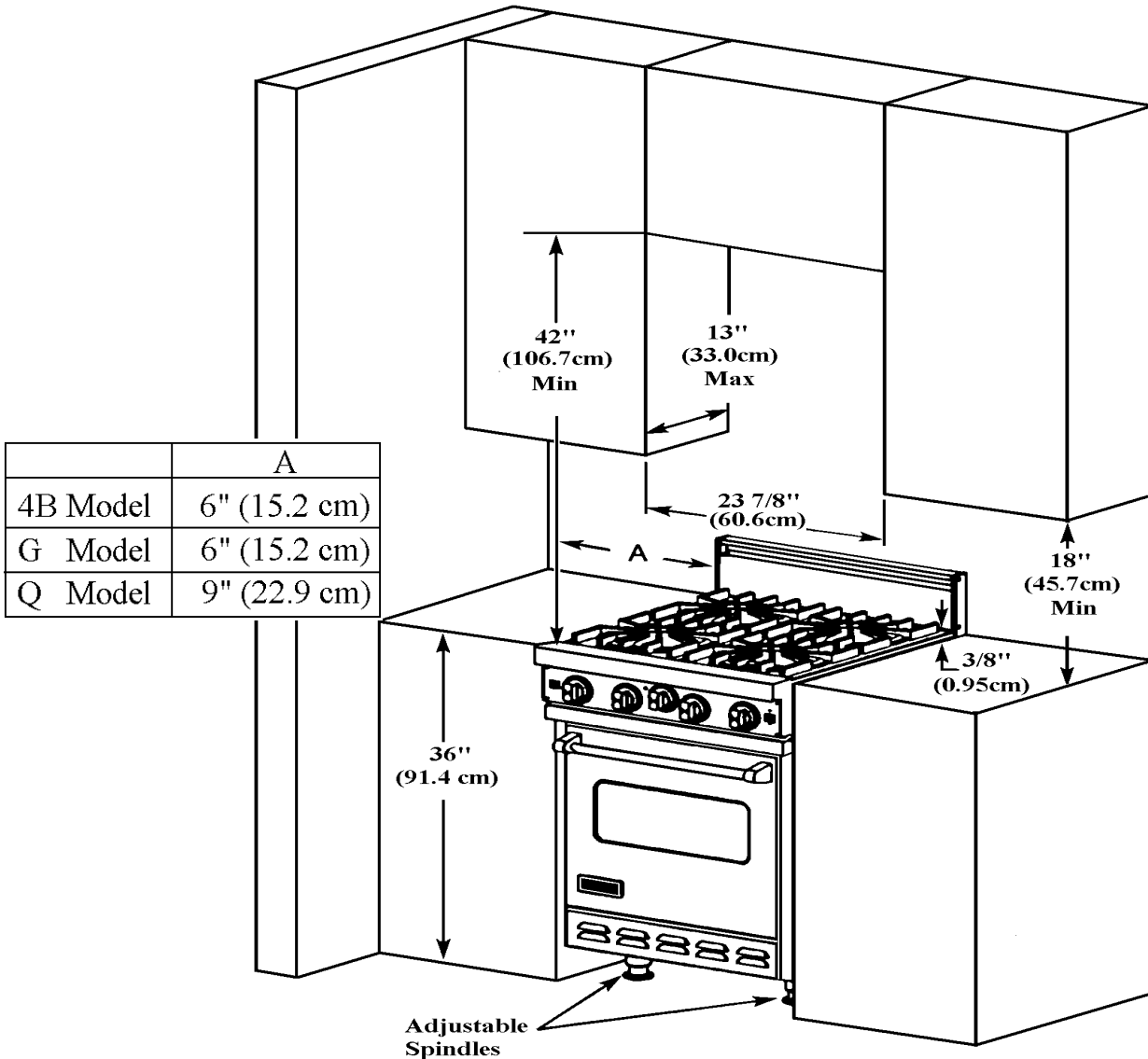

STABILITY DEVICE INSTALLATION INSTRUCTIONS

1. The anti-tip bracket is to be attached to the rear wall as shown. The dimension for the bracket location from the floor is to be determined after the range leg have been adjusted to the proper installation height shown in the installation instructions and the range has been leveled.
2. Measure from the floor to the bottom of the anti-tip opening located on the back of the range
3. Locate the anti-tip bracket on the wall with the top left corner at the measured dimension (A) plus $\frac{1}{2}$ " (1.3cm) from the floor and $\frac{5}{8}$ " (14.3cm) from where the left side of the range (facing range) is to be located
4. Slide range into place. Be sure the anti-tip bracket slides into the anti-tip opening.

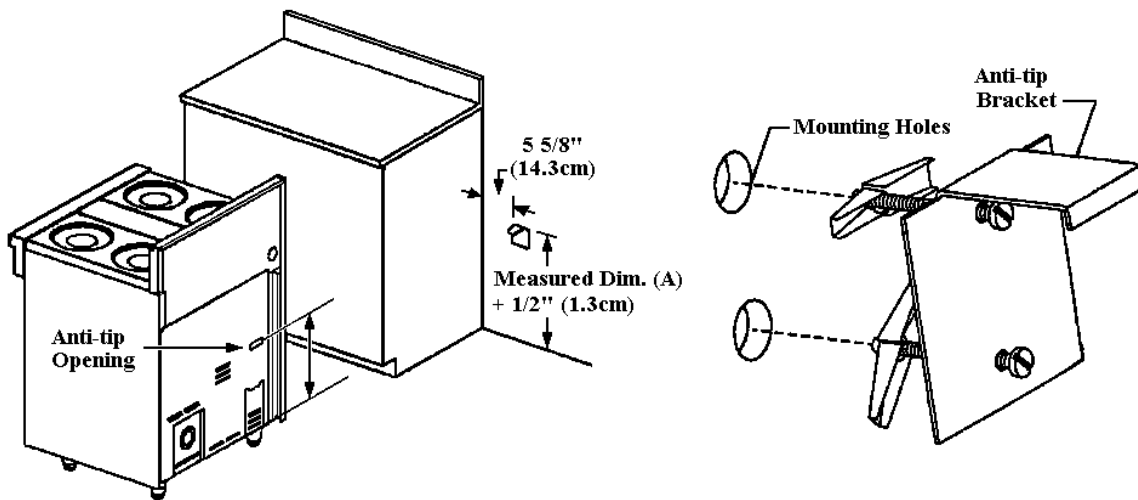

RANGES EQUIPPED WITH CASTERS

1. Adequate means must be provided to limit the movement of the range casters without depending on the connector and /or quick disconnect device. The “restraint” should be inspected as part of the maintenance and safety procedure. Restraint cable must be connected at all times when range is in use.
2. When using the quick disconnect device and /or casters, the “restrainer” must be attached to the wall and to the rear of the range.
3. If disconnection of the restraint is necessary, ensure the restraint is reconnected after the range has been returned to its original position.

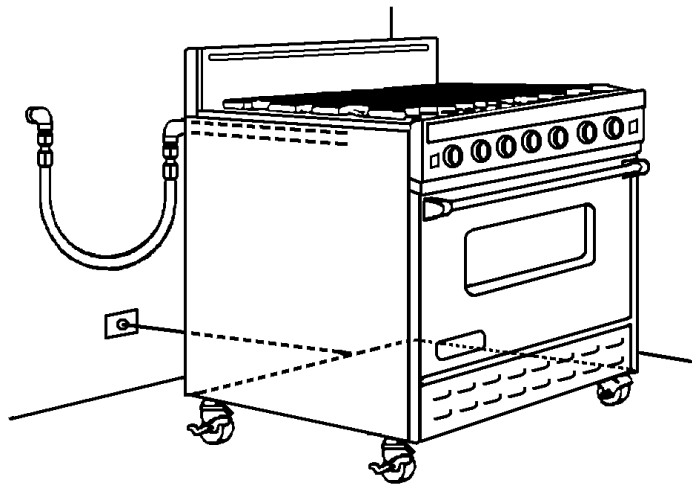

RANGE LEVELING

Careful leveling of the range is critical not only to performance, but also to allow the alignment of oven doors and drip tray. Closely follow the procedures below to ensure proper performance and appearance of the range. The range being even slightly out of level will significantly contribute to misalignment of oven doors.

1. If the floor is smooth and level, level the unit with the screw thread of the legs. Set the high corner of the range so that the top of the grate support is 3/8" above the countertop, and level the range to the high corner.

2. If the floor is uneven or has a decided slope, level the unit with metal shims, as the adjustment required may exceed the thread available in the leg.

3. Proper and careful leveling of the range is necessary for proper alignment of the oven doors.

- The body of the range does not have a rigid frame to hold it into one position. This non-rigid framework allows the range to shift with un-level floors or slanted cabinets.
- Moving any one of the adjustable leveling legs up or down will shift the range body. Use the vertical line between the edge of the door and the left side trim or center trim on the 2 door models to adjust the leveling legs.

When adjusted properly this space will be uniform from the top to the bottom of the door. The bottom corner of the end panel will move in or out. Adjust this lower corner to have an equal space from the top to the bottom of the door.

- Increasing the length of the right front leveling leg will raise the right front corner of the range, moving the top of the door to the left. Lowering the right

front leveling leg will cause the top of the door to move to the right.

- Using the left front leveling leg will give you the opposite effect. Raising the left front corner will move the top of the door to the right. Lowering the corner will move the top of the door to the left. The rear leveling legs will also have an effect on the door alignment.

4. After the range is properly leveled, the drip tray handle may be aligned by loosening the screws and adjusting the handle horizontally within the limits provided by the slotted screw holes.

5. A carpenter's spirit level should be placed across the top of the range and the unit leveled front-to back, side-to side and vertically. If it is not level, burner combustion may be erratic, liquid or semi-liquid batters will cook at an angle, and the unit may not function efficiently.

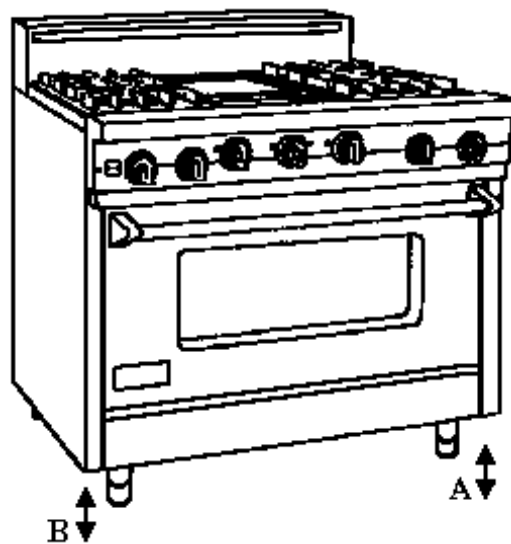

**A. Right Side Front /
Back Adjustment Legs**

**B. Left Side Front /
Back Adjustment Legs**

WOOD/COMPOSITE OVERLAY INSTALLATION

The bottom of the hood should be no less than 27" (68.6cm) above the grates. It is more desirable for the bottom of the hood to be 29 5/8" to 35 5/8" above the grates. This would typically result in the bottom of the hood being 66" (167.6cm) to 72" (187.9cm) above the floor. The bottom of the hood should never be more than 72" (182.9cm) above the floor or more than 35 5/8" (90.5cm) above the grates. These dimensions provide for safe and efficient operation of the hood.

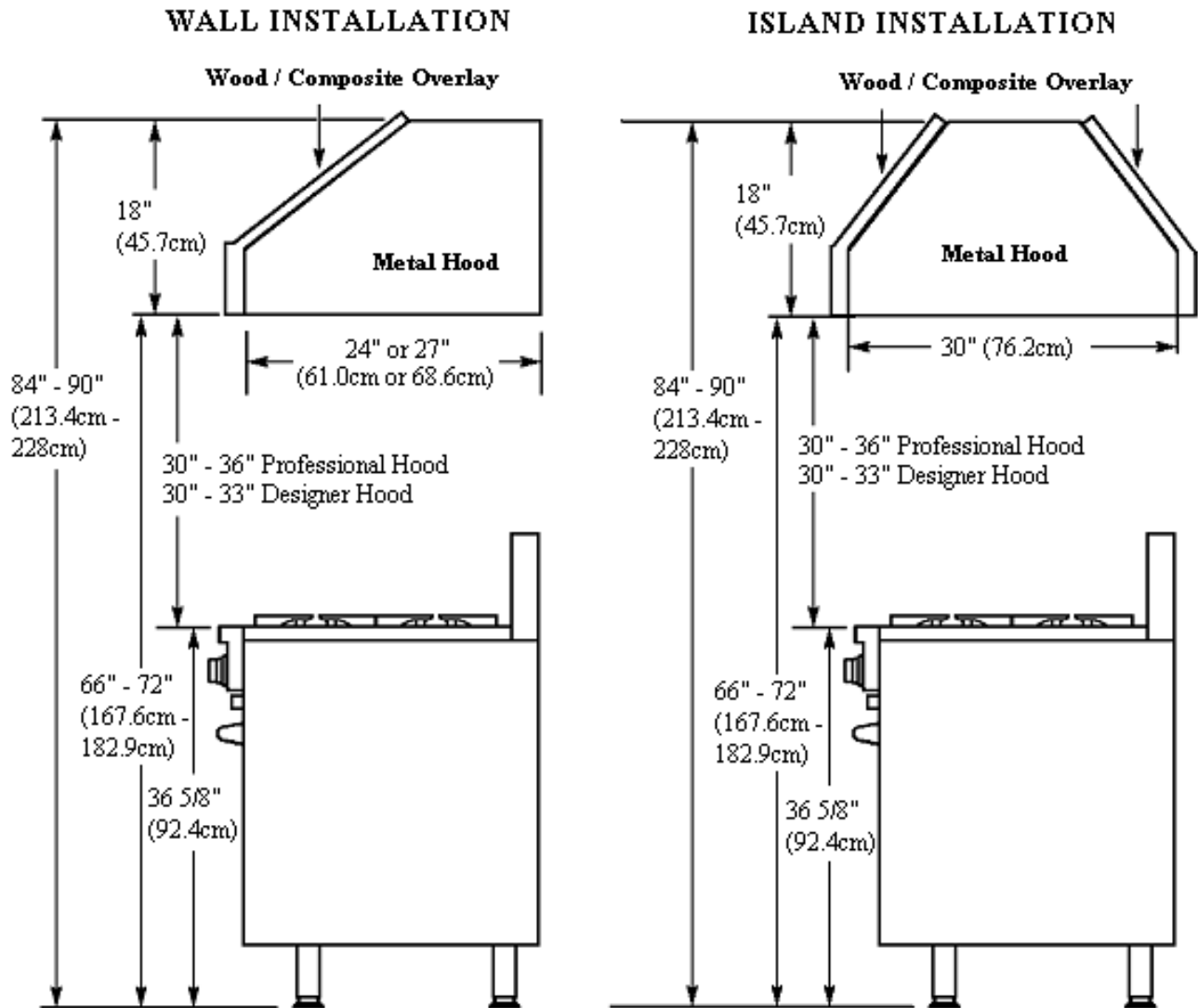

COMPONENTS (WITH COLOR CODED WIRIES)

CONTROL CIRCUIT BOARD (P.C. BOARD) DUAL FUEL SELF-CLEAN FREE-STANDING RANGES WITH SEALED BURNERS

Function: The Door Lock Control / Timer is activated by the line voltage at the "SEL" (1) contact. Relay "RL1" (2) and "RL2" (3) close providing voltage to the Door Lock Motor. The Relays stay closed until 10 seconds after sensor #3 (4) receives a signal that the Door Lock is fully closed. Once this happens Relay "RL2" (3) opens to stop the Door Lock Motor. Relay "RL1" (1) stays closed providing voltage to the Auto Reset thermostat. Relays "RL3" and "RL4" close powering the Cooling Fan Motor and Cycle Relay. "RL3" and "RL4" will stay closed for 3 1/2 hours unless power is interrupted to sensor #3 (4) or SEL (1). In which case "RL3" and "RL4" will open, interrupting the clean cycle and Cooling Fan, and "RL2" (3) will close, opening the Door Lock. "RL2" (3) will stay closed until 2 seconds after sensor #4 (5) is powered.

AUTO RESET SWITCH: DUAL FUEL SELF-CLEAN FREESTANDING RANGES WITH SEALED BURNERS

Function: The Auto Reset Switch is a single pole / double throw switch (thermostat) which is activated by a thermo-bulb and lever which is calibrated to 575* F plus / minus 25* F. **Clean door lock below 575* F.** The Door Lock Motor is energized through the Auto Reset Switch (thermostat) contacts 2 - 1. **Clean door lock above 575* F.** Auto Reset Switch (thermostat) switches to contacts 1 -3 turning on the Door Lock indicator Light and disables the Door Lock Motor circuit. **Final below 575* F.** Auto Reset Switch (thermostat) switches to contacts 1 -2, turning off the Door Lock Motor circuit through door Lock Motor / Timer Relay LS2 - M1. Door Lock Motor operates until 2 seconds after sensor 4 is signaled by VC that the Door Lock switch SW1 has been closed mechanically by the door lock bolt. The Door Lock / Timer switches LS2 - M1 and LS1-L1 open and the timer resets.

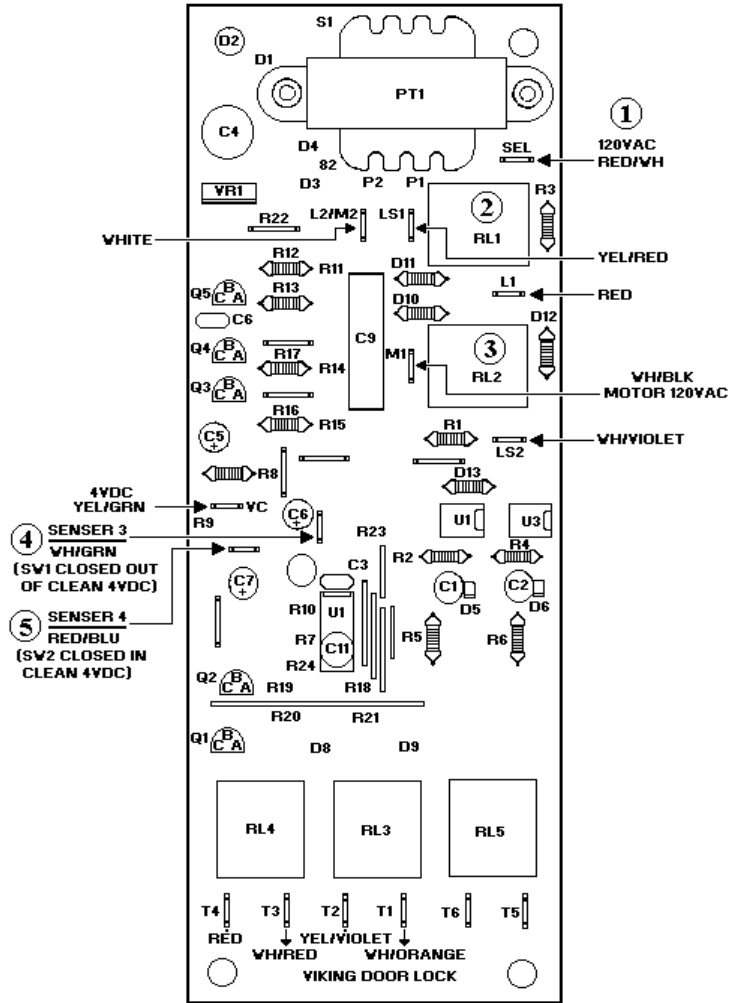

CONTROL CIRCUIT BOARD

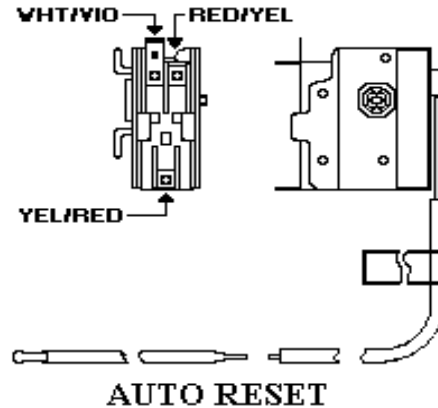

HIGH LIMIT SWITCH: DUAL FUEL SELF-CLEAN FREE-STANDING RANGES WITH SEALED BURNERS

Function: The Switch has a ½ “ bi-metal disc. The two metals have different thermal coefficients of expansion which cause the disc to bow as it heats up. When it reaches the calibration temperature the disc snaps open, which opens the electrical contacts. The Switch opens when temperature reaches 275°F plus or minus 9°F and will close when temperatures are 248° F plus or minus 9°F.

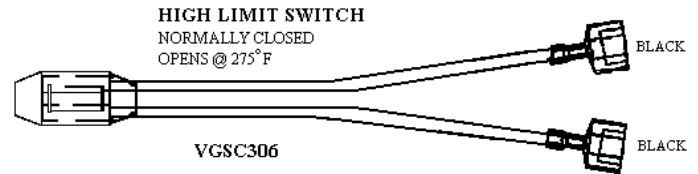
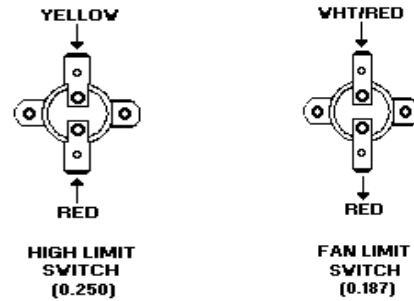

COOLING FAN LIMIT SWITCH: DUAL FUEL SELF-CLEAN FREE-STANDING RANGES WITH SEALED BURNERS

Function: The Switch has a ½ “ bi-metal disc. The two metals have different thermal coefficients of expansion which cause the disc to bow as it heats up. When it reaches the calibration temperature the disc snaps closed, which closes the electrical contacts. The Switch closes when temperatures reach 230°F plus or minus 9°F and will open when temperatures are below 203°F plus or minus 9°F.

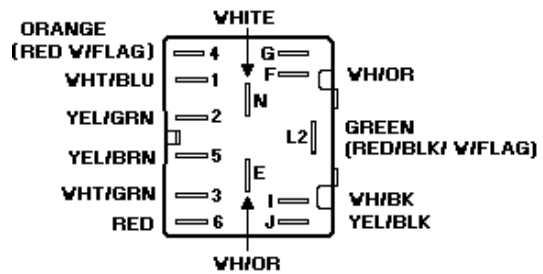

SELECTOR SWITCH (8 POS)

SELECTOR SWITCH (8 POS) (PJ030001)

Function: Rotating the shaft twists a cam which moves one or more spring loaded levers, which make contact with a terminal closing the circuit.

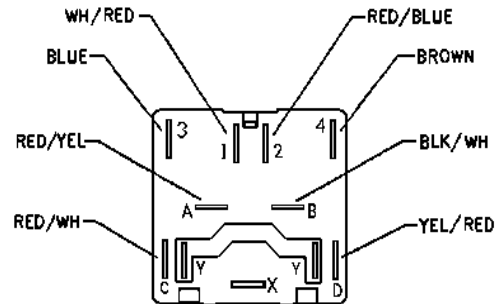

SELECTOR SWITCH (PJ030009) VDSC485(LH)

SELECTOR SWITCH (3 POS)

SELECTOR SWITCH (3 POS) (PJ030010)

OVEN THERMOSTAT

Function: As the shaft is rotated from the OFF position clockwise, an internal cam pushes a lever, which increases the temperature at which the thermostat cycles. Rotating the shaft 212° (angle °) switches an external (clean) Micro Switch to the closed position.

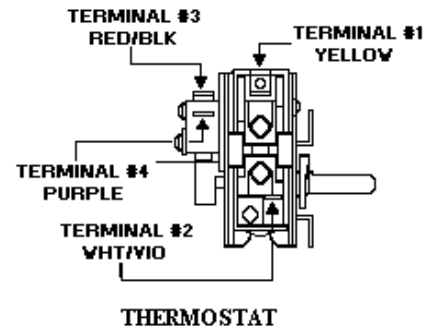

COMPONENTS (continued)

DOOR LOCK MOTOR:DUAL FUEL SELF-CLEAN FREESTANDING RANGES WITH SEALED BURNERS'

Function: When the Door Lock Motor is powered it turned a cam which pulls back a lever. As the lever moves back it allows a micro switch (SW1) to open. When the lever reaches the fully closed position it closes a double stacked micro switch (SW2 & SW3). **Door lock switch SW2** completes the circuit to sensor #3 on the Door Lock Control/timer board. After 10 seconds LS1-M1 opens, stopping the Door Lock motion. **Door Lock Switch #3** closes T1-T2 and T3-T4 energizing Power Relay #1 and the Cooling Fan. Closing Power Relay contacts supplies 240 VAC to both Broil Elements and 120 VAC to the Bake Element.

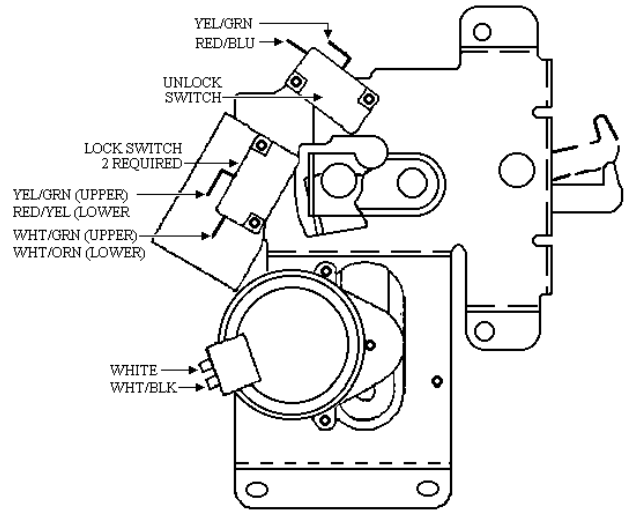

POWER RELAY #1 (PM010129): DUAL FUEL SELF-CLEAN FREESTANDING RANGES WITH SEALED BURNERS

Function: Relay #1 (power) supplies power to the Bake and Broil Elements.

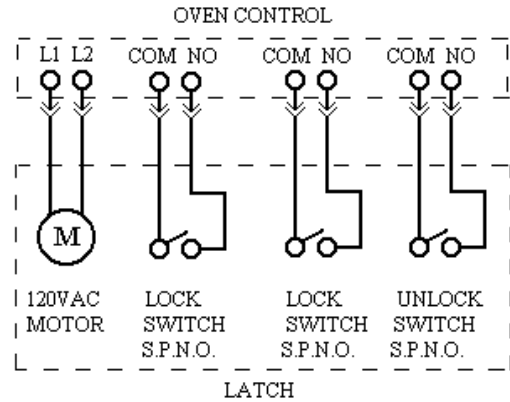

RELAY #2 - #3 - #5 - #6

VEDO205 (PM010020)

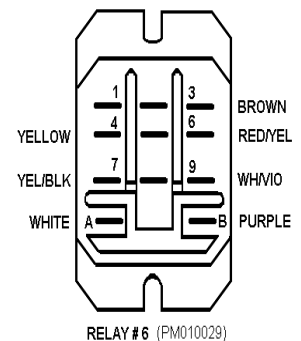
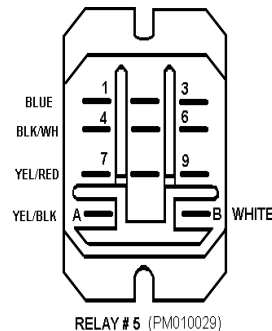
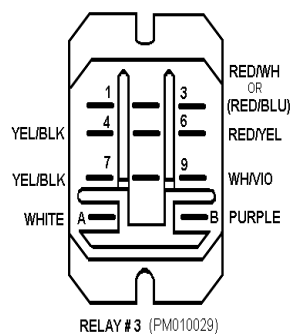
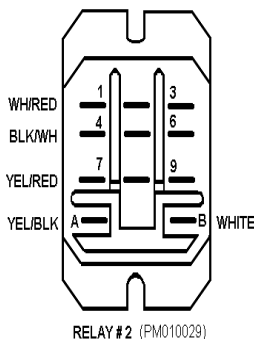
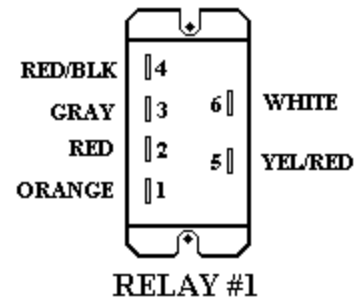

COMPONENTS (continued)

RELAY #2 – #3 - #5 (PM010025): DUAL FUEL SELF-CLEAN FREE- STANDING RANGES WITH SEALED BURNERS.

Function: Setting the selector switch to clean closes the Heating Element circuits 4-F, 1-N, 2-L2, 3-L2 and Door Lock Module / Timer circuit J-6, energizing Relay #2. The thermostat cycling contacts 1 to 2 and the clean switch contacts 3 to 4 close energizing Relay #3. Relay #3 allows circuit J-6 to turn on the Clean Indicator Light and enable the Door Lock Module / Timer to close Relays LS1-L1 and LS2 - M1. This powers the Door Lock Motor until 10 seconds after Sensor 3 is signaled by VC that Door Lock Switch SW2 has been closed mechanically (along with SW3) by the Door Lock Bolt.

RELAY #4 (PM010129)
VDSC485 (LH)

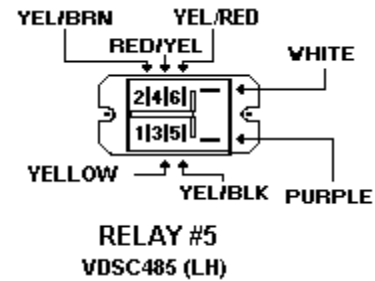
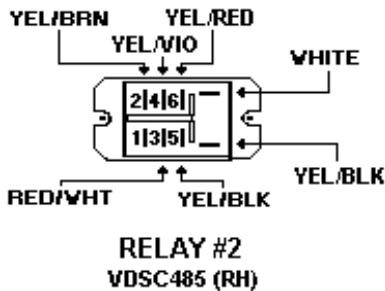
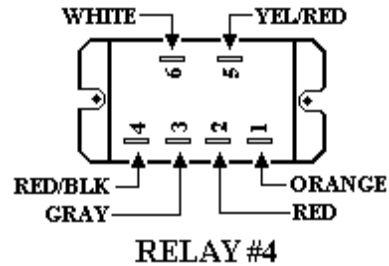
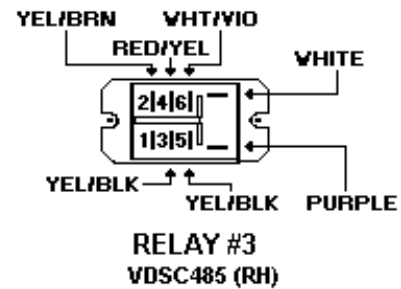
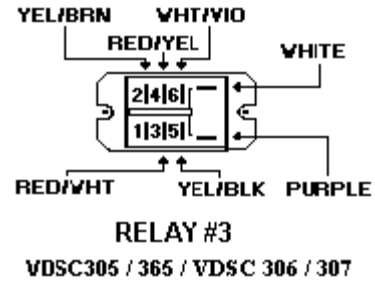
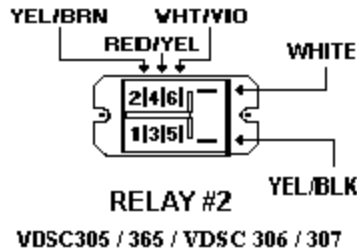

COMPONENTS (continued)

CONVECTION FAN MOTOR:DUAL FUEL
SELF-CLEAN FREE STANDING RANGES WITH
SEALED BURNERS

Function: Provides an even flow of air
in the oven cavity for more even
baking.

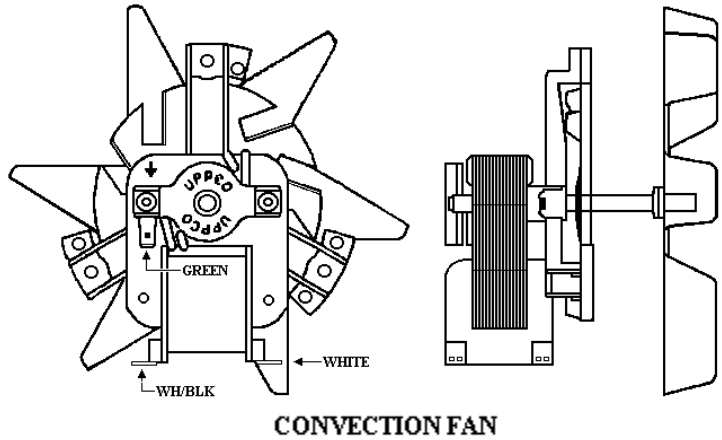

COOLING FAN MOTOR

Function: Provides a continuous supply
of cool air during self clean cycles to
keep the Door Lock Motor and
associated circuits cool.

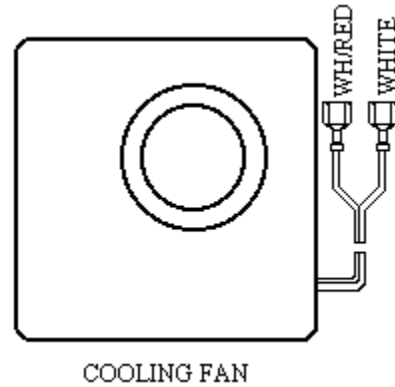

OVEN LIGHT

Function: Provides interior oven light for
viewing baking products.

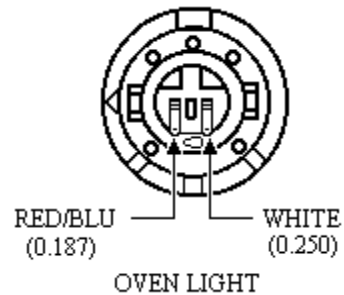

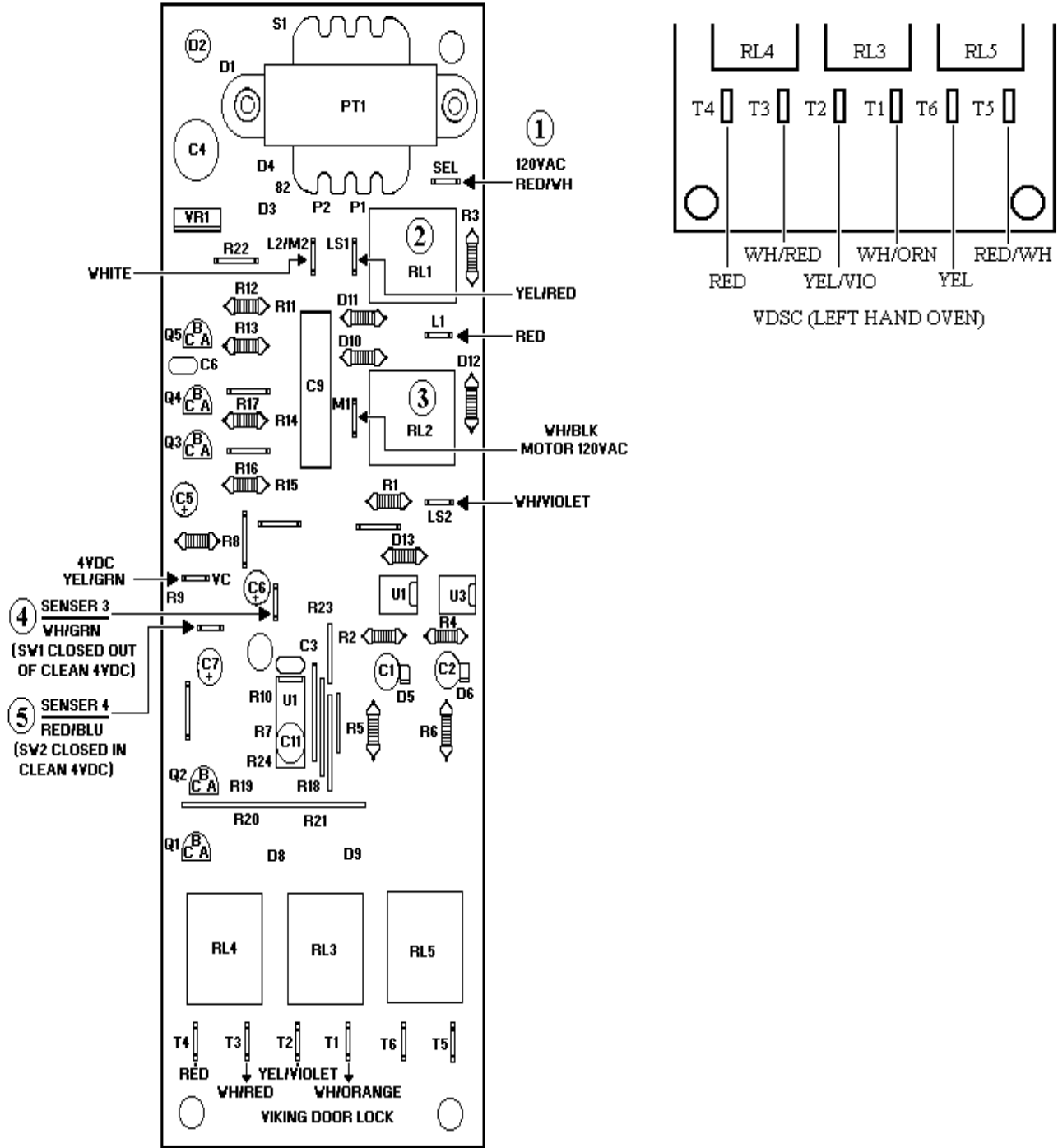

P.C. CONTROL BOARD WIRING FOR RELAYS T4 – T3 – T2 – T1 – T6 – T5





CONTROL CIRCUIT BOARD

VOLTAGE READINGS

MEASURED WITH DOOR OPEN

		
T4	107VAC	70VAC
T3	4VAC	16VAC
T2	4VAC	16VAC
T1	5VAC	1VAC

MEASURED WITH DOOR LOCKED

T4	80VAC	56VAC	
T3	85VAC	56VAC	
T2	90VAC	56VAC	
T1	93VAC	56VAC	

VC--4VDC

SENSOR 3--3VDC SW2 closed in self clean (Locked). 

SENSOR 4--4VDC SW1 closed with clean lock open. 

M1--120VAC lock motor supply voltage.
(31VAC in locked position)

LS2--70VAC (unlocked)--**55VAC** (locked)

L1-- 70VAC (unlocked)--**56VAC** (locked) 

L2/M2--16VAC(unlocked)--**32VAC**
(locked)

LS1--107VAC (locked or unlocked)

SEL--120VAC SUPPLY

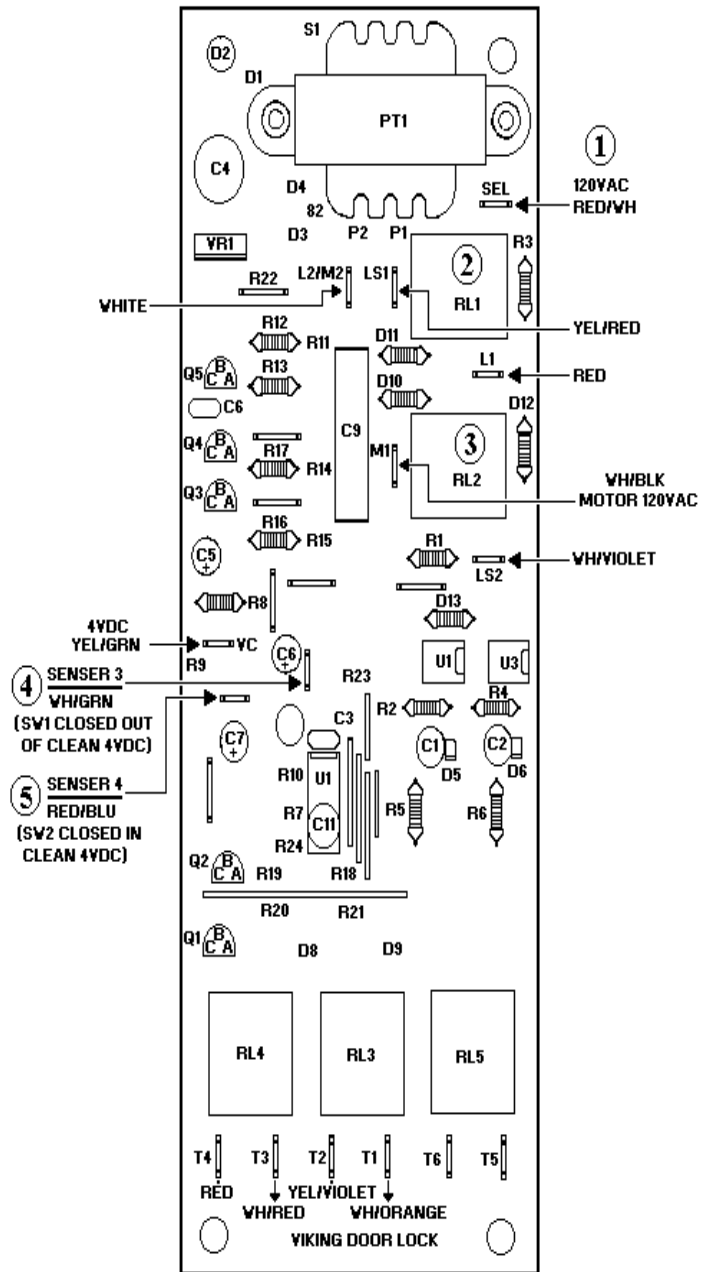
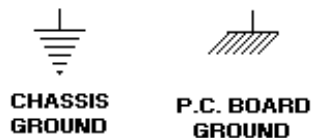

CONTROL CIRCUIT BOARD

8 POSITION SELECTORSWITCH (With shaft position and internal connections)

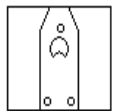
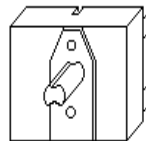
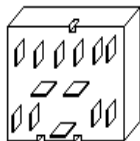
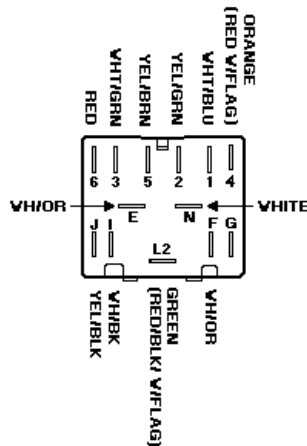

OFF

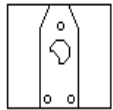
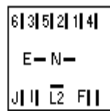

BAKE

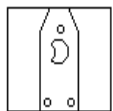
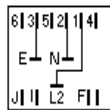

CONVECTION
BAKE

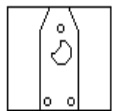
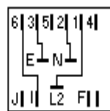

CONVECTION
COOK

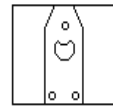

BROIL

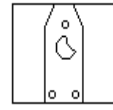
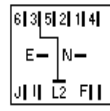

MAXI
BROIL

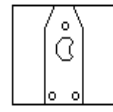
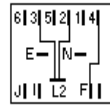

CONVECTION
BROIL

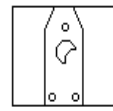
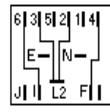

SELF
CLEAN

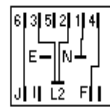

SELF CLEAN

Selector Switch closes Heating Element contacts 4-F, 1-N, 2-L2, 3-L2, and Door Lock Module / Timer contacts J-6 energizing Relay #1.

Thermostat Clean Position closes Thermostat cycling contacts 1-2 and normally open (N) - common (C) energizing Relay #3.

Relay # 3 turns on the Clean indicator Light and energizes Door Lock Module / Timer (PC Board) relays LS1-L1 and LS2-M1, also supplying 120VAC to SEL on the PC board

Relays LS1 and LS2 turns the Door Lock Motor on through the Auto Reset Thermostat contacts 2-1.

Door Lock Motor rotates opening SW1 and closing SW2 and SW3.

Door Lock Switch #2 completes the circuit to sensor #3 on the PC board. After 10 seconds LS1-M1 opens, stopping the Door Lock motion.

Door Lock Switch #3 closes T1-T2 and T3-T4 energizing Power Relay #1 and the Cooling Fan. Closing Power Relay #1's contacts supplies 240VAC to both Broil Elements and 120VAC to the Bake Element.

CLEAN DOOR LOCK ABOVE 575°F ± 25°F

Auto Reset Thermostat switches to contacts 1-3 turning on the Door Lock indicator Light and disables the Door Lock Motor circuit.

CLEAN TEMPERATURE (875°F) REACHED.

Door Lock Module / Timer opens T3 -T-4 and T1-T2 turning off the Cooling Fan, now powered by the Fan Limit Switch when needed, and opens the circuit to the Power Relay #1 disabling the Heating Elements.

FINAL BELOW 575°F ± 25°F

Auto Reset Thermostat switches to contacts 1-2. turning off the Door Lock Motor circuit through Door Lock Motor / Timer Relay LS2-M-1. Door Lock Motor operates until 2 seconds after sensor 4 is signaled by VC that the Door Lock /Timer switches LS2- M1 and LS1-L1 open and the Timer reset.

OVEN TEMPERATURE CALIBRATION

DUAL FUEL RANGES SELF-CLEAN FREESTANDING RANGES WITH SEALED BURNERS

Electric oven calibration using the EATON thermostat. The adjustment screw is located on the bottom of the thermostat (3/32 Allen head screw). Each 1/4 turn is equal to approximately 35 degrees. **COUNTER CLOCKWISE** adjustment will **DECREASE** the temperature. **CLOCKWISE** adjustment will **INCREASE** the temperature.

If the oven temperature is off more than 50 degrees you should replace the thermostat.

REMEMBER WHEN YOU CHANGE THE OVEN TEMPERATURE YOU ARE ALSO CHANGING THE SELF-CLEAN TEMPERATURE. (As a rule of thumb you should only calibrate the thermostat to increase the oven temperature.)

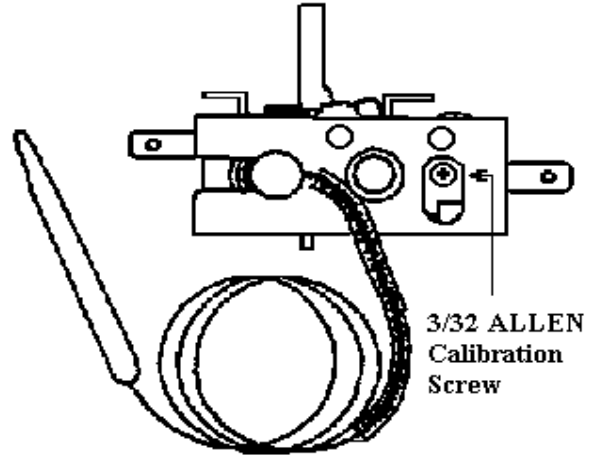

- A. **Center Oven Temperature Check:** Before turning the oven on, check the thermostat sensor bulb position. It should be straight, no kinks and secured in the mounting clips.
- B. Place the oven rack in the center of the oven.
- C. Place a loaded thermocouple lead in the center of the rack and close the door. Avoid touching metal with the thermocouple junction.
- D. Set the selector switch to “BAKE” and the temperature dial to 350°F.

NOTE: Do not overshoot the 350°F mark. When you go beyond 350°F, return the control to the lowest setting and reset to 350°F.

- E. Cycle the oven 5 times; Average the 3rd, 4th, and 5th cycles. The temperature is acceptable if the average is 350°F ± 25 °.

TEMPERATURE: CONVENTIONAL OVEN

CYCLE	1	2	3	4	5	AVERAGE
HIGH	(XX)	(XX)	()	()	()	()
LOW	(XX)	(XX)	()	()	()	()

- F. For convection test lower the oven temperature to 325°F. Preheat the oven with convection fan on.

TEMPERATURE; CONVECTION OVEN

CYCLE	1	2	3	AVERAGE
HIGH	(XX)	()	()	()
LOW	(XX)	()	()	()

- G. On conventional baking place pans in the center of the oven.
- H. On convection baking place pans on rack positions 2 and 4.
- I. Uneven temperatures left to right in the oven:
 1. Check air shutter adjustment: sharp blue flame, no yellow tipping.
 2. Check orifice hood adjustment.

VOLTAGE and RESISTANCE READINGS

BAKE ELEMENT:

“A” to “B” 21.1 Ohms

“A” to “B” 240VAC during Bake and Convection Bake.

30” – 2750 Watts

36” – 3250 Watts

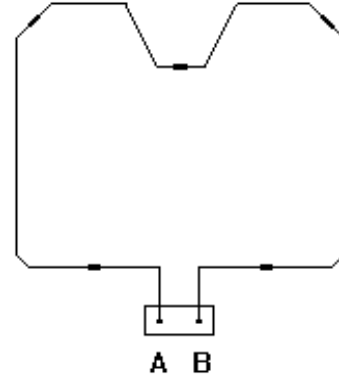

BROIL ELEMENT:

“A” to “D” (outside element) 32.6 Ohms

1750 – Watts

“A” to “D” 50VAC during Bake and Convection Bake.
240VAC during Maxi Broil.
240VAC during Convection Broil
240VAC during Self-clean

“B” to “C” (inside element) 45.2 Ohms

1250 Watts

“B” to “C” 70VAC during Bake and Convection Bake.
240VAC during Mini Broil
240VAC during Maxi Broil
240VAC during Convection Broil
240VAC during Self-clean

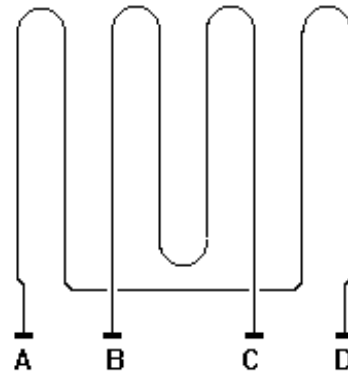

CONVECTION ELEMENT:

“A” to “B” 26 Ohms

“A” to “B” 240VAC during Convection Cook

2200 Watts

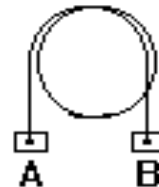

VDSC367 DISASSEMBLY

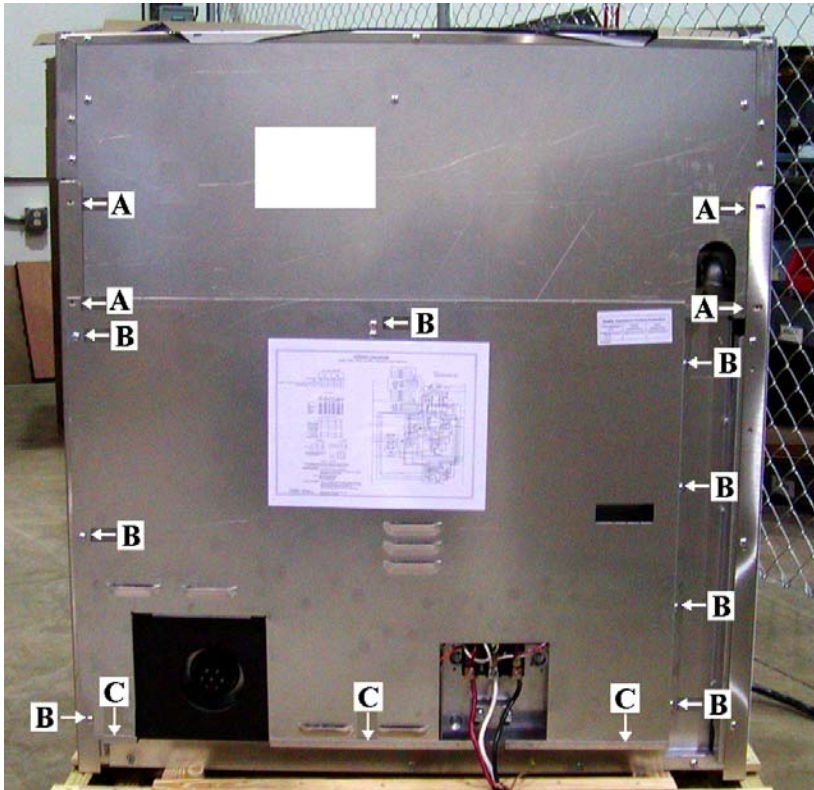

1. Remove the Range out from the installation.
2. Remove the screws marked "A" to remove the backguard.
3. Remove the screws marked "B" to remove the back panel.
4. The bottom of the back panel sets behind the lower base plate marked "C". Tilt out at the top and lift up to remove the back panel.

BELOW IDENTIFY THE COMPONENTS AND THEIR LOCATION.

- A. Surface Burner Spark Module
- B. Relays #1 and #2
- C. Air Channel to Cool Lock Components.
- D. Cooling Fan Motor
- E. Self-clean Timer Board
- F. Convection Fan
- G. Terminal Block
- H. Auto Reset
- I. Pre-heat Board
- J. Oven Light Socket
- K. Regulator
- L. Smoke Eliminator Exhaust Channel
- M. L. P. Orifices
- N. Disconnect
- O. Disconnect

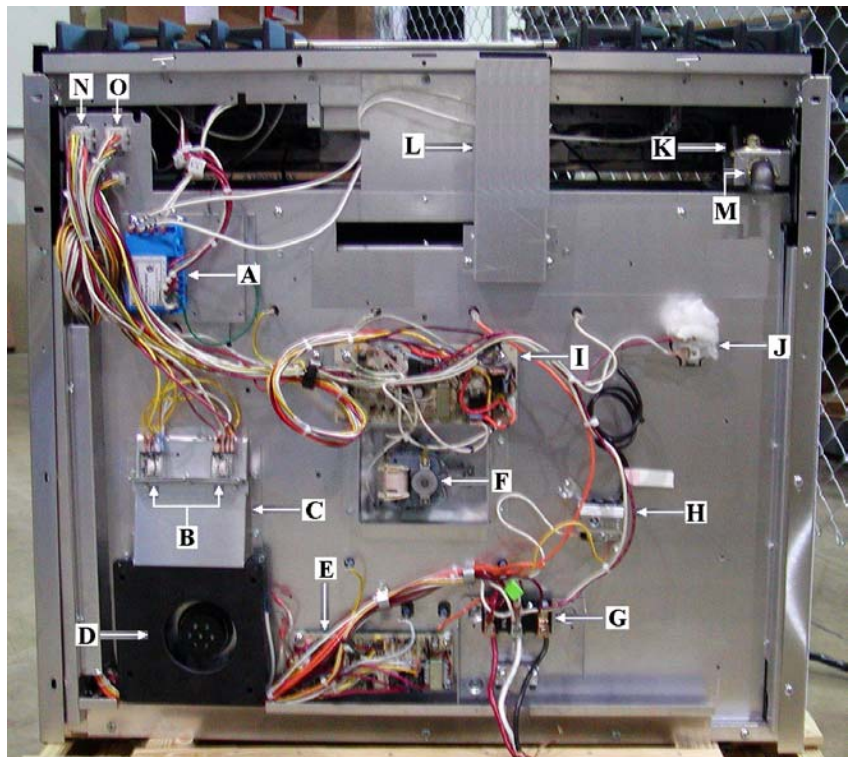

RANGETOP

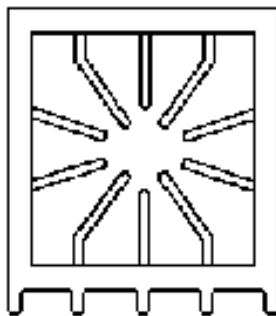

BURNER GRATE

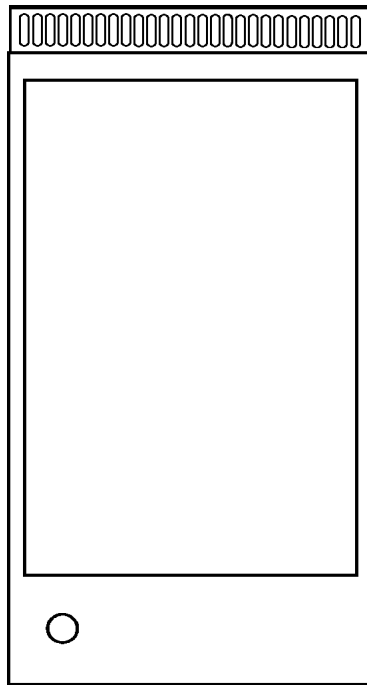

Griddle

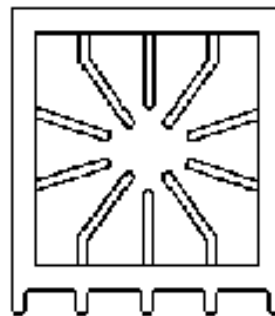

BURNER GRATE

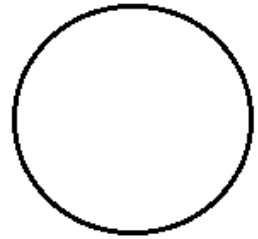

BURNER CAP

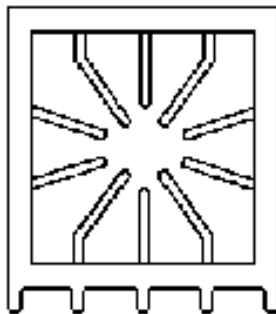

BURNER GRATE

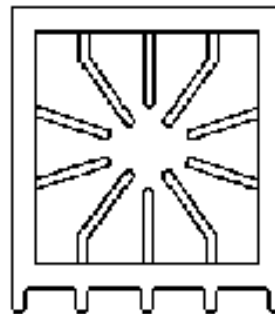

BURNER GRATE



BURNER HEAD

To gain access to the components beneath the top assembly (1) Remove the Grates , (2) Burner Caps, (3) Remove the Burner Heads., and (4) Lift the griddle out (there is a thermal sensor under the griddle shield see next page).

GRIDDLE ASSEMBLY

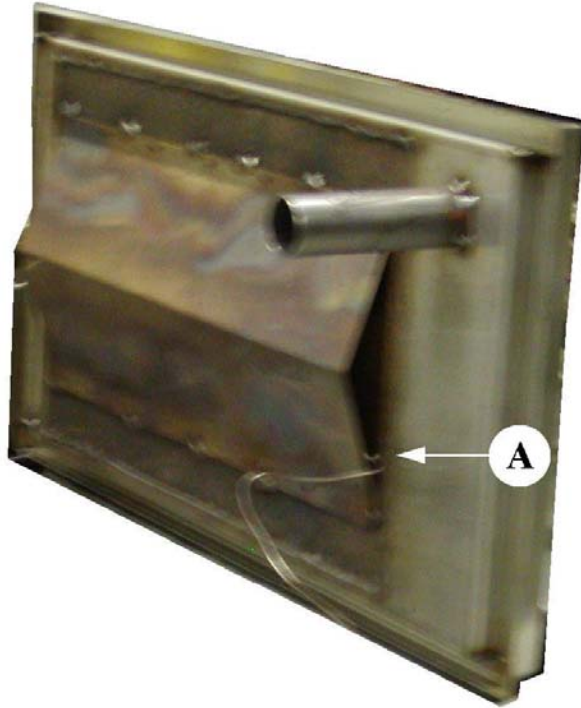

A. Thermal Bulb tube

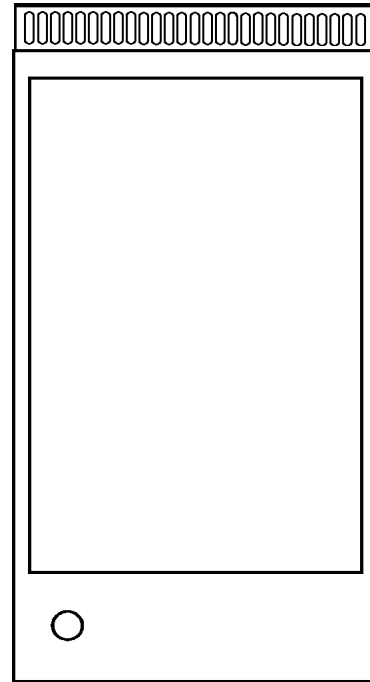

Griddle

Use care to remove the Thermal Bulb from the bulb tube. After removing the Thermal Bulb the Griddle can be placed aside. Place the griddle on a protective surface to keep from marring the customers property.

To remove the main top:

- A. Remove the Surface Burner Knobs
- B. Remove the 2 lower bezel screws (B) that holds the control panel to the chassis.
- C. Remove the 4 screws (C) that hold the control panel to the burner box.
- D. Remove the 4 screws (D) that hold the landing ledge (E) in place.



With the Control Panel pulled forward you can service the following components.

- A. Spark Igniter Switches
- B. Screws that hold the Landing Ledge (H) to the burner box.
- C. Brackets that hold the control (J) panel in place.
- D. Light Switch
- E. Griddle Thermostat
- F. Selector Switch
- G. Oven Thermostat

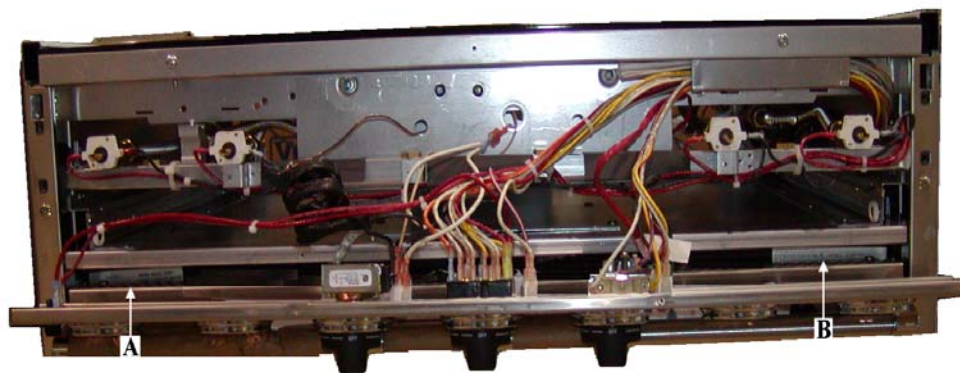
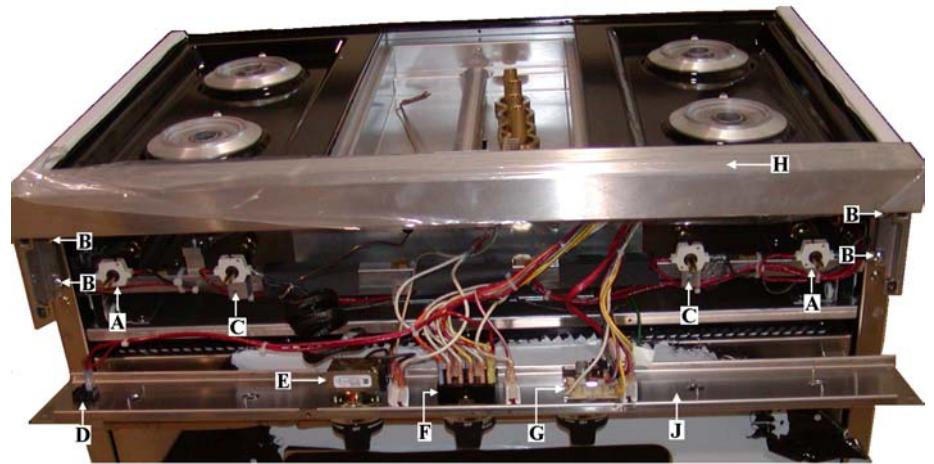

- A. Serial Plate
- B. Tech Manual

To remove the Main Top Assembly (E), remove:

- A. Remove the 4 Venturi (A) wrapping the jaws of a pair of channel locks with several turns of tape to keep from scoring the brass venturi.
- B. Lift the Burner Bases (C) and disconnect the igniter wires (D).

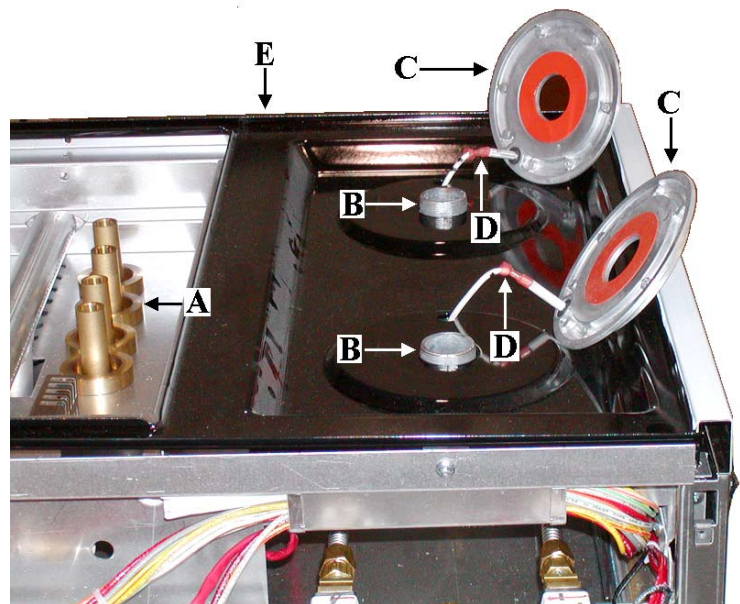

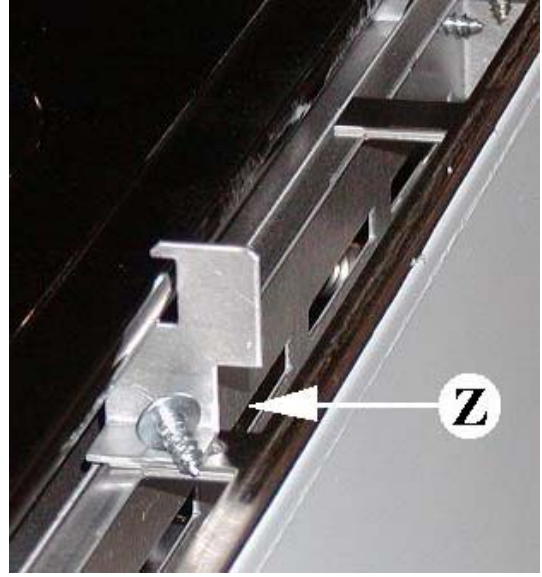
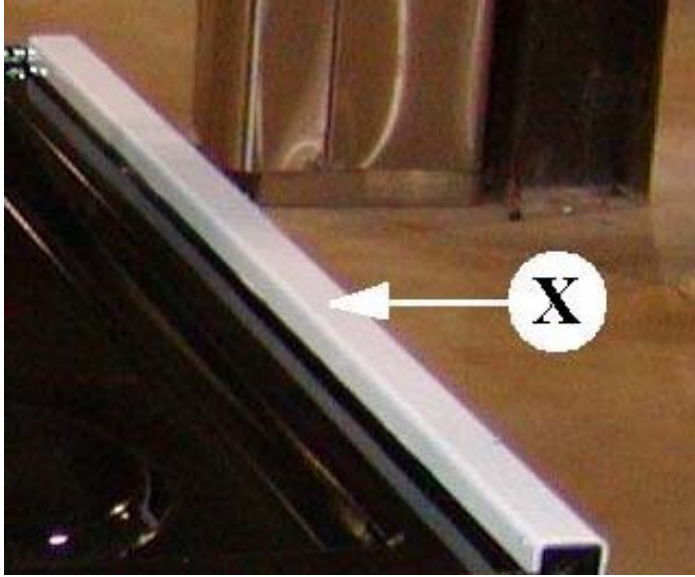

To complete the removal of the main top:

- A. Remove the each side trim (X)
- B. Remove the brackets that hold the main top in place.

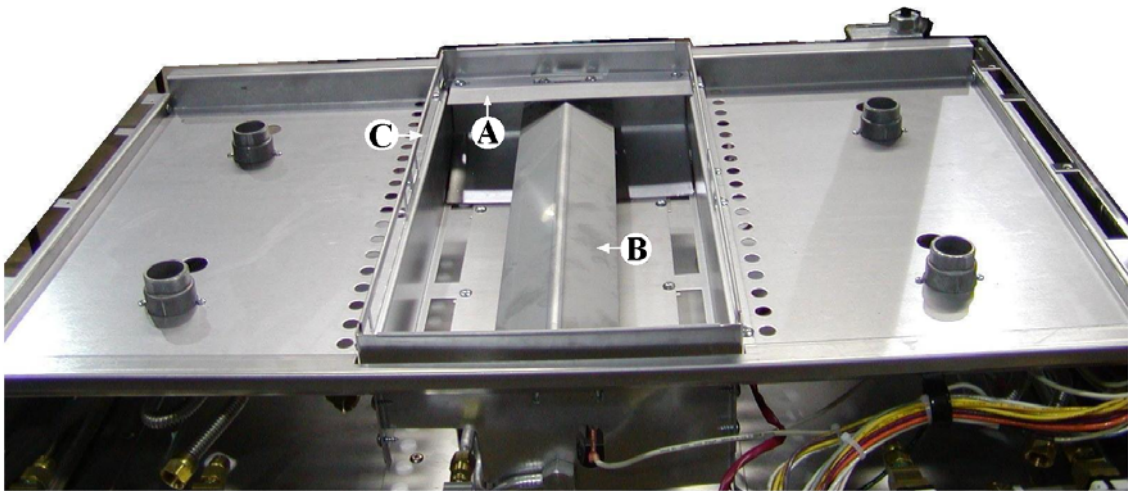

- A. Rear Support
- B. Burner Cover
- C. Burner Box

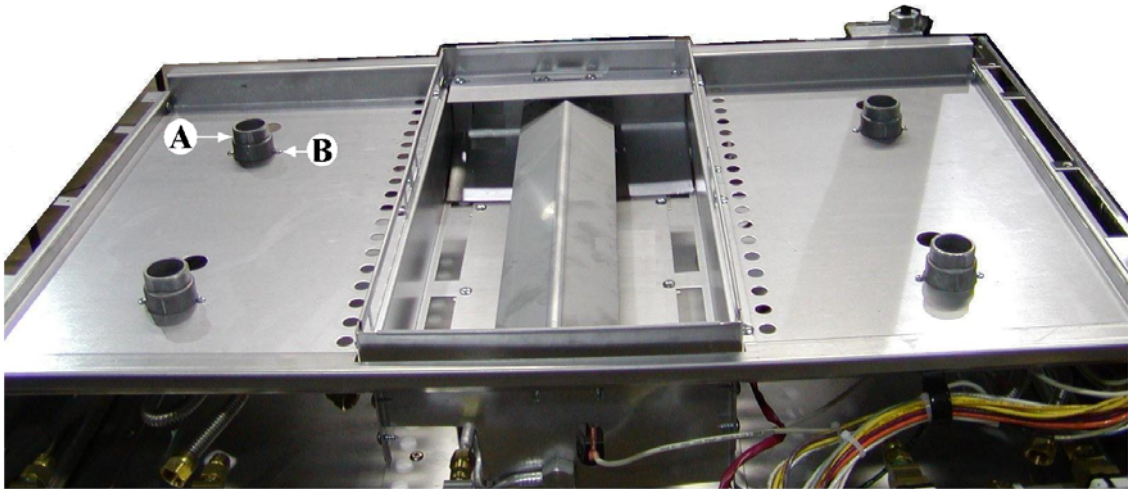

- A. To remove the burner base:
- B. Remove the two screws marked (B above) that hold each burner base to the support.
- C. The Burner Base (A below) is now free to service the gas connection (B below) to the burner valve (C below).
- D. Thread the igniter wires through the opening when reassembling the top.

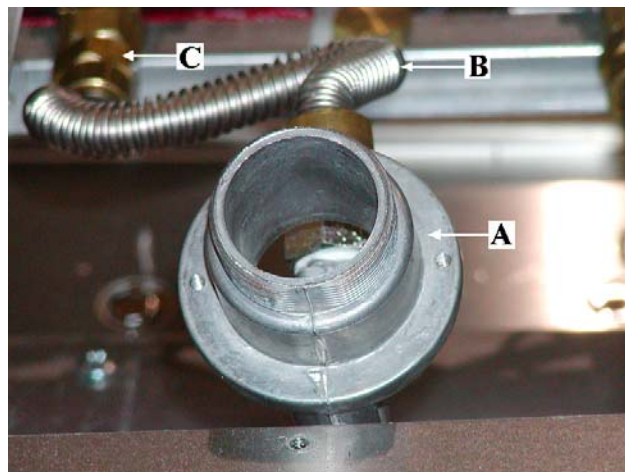
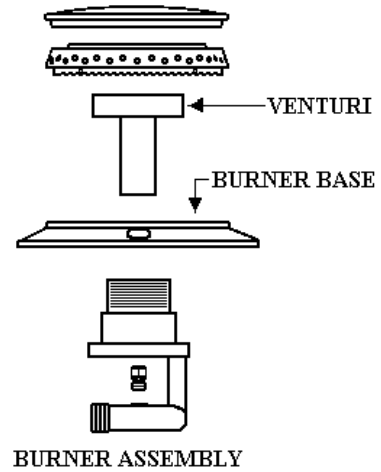
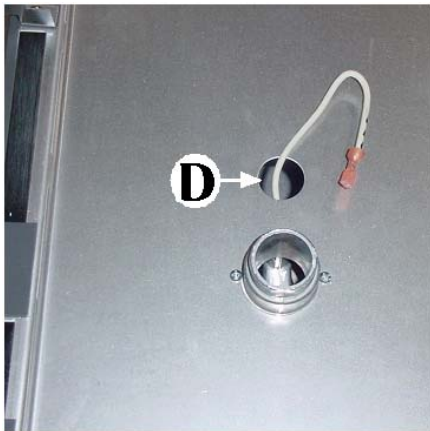

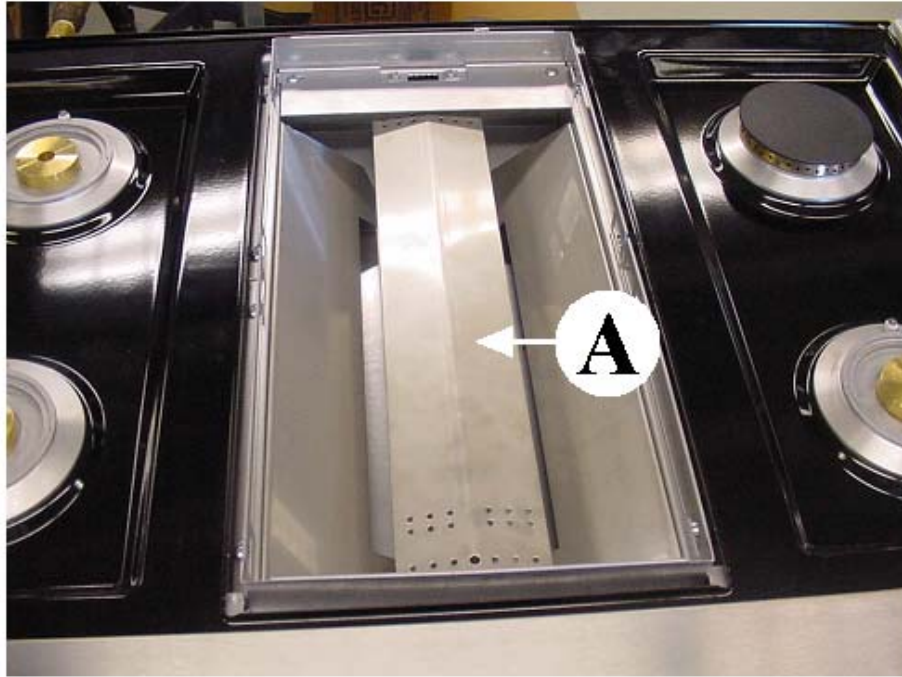

Remove the Heat Shield (A) to service the Griddle Gas Burner, Igniter, Thermostat Sensor Bulb.

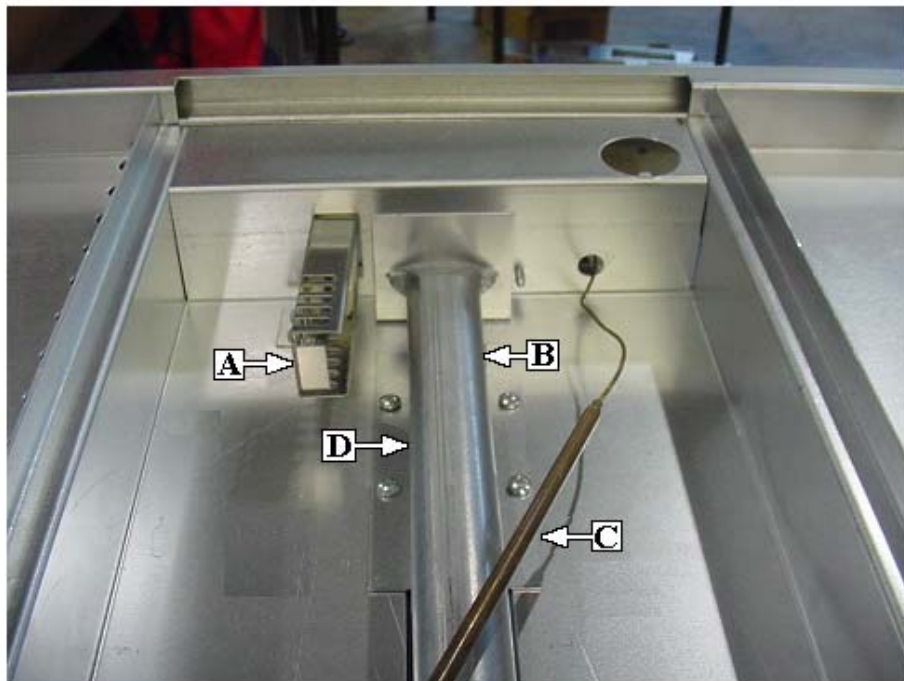

- A. Igniter
- B. Burner
- C. T-stat Sensor bulb
- D. Venturi Cover

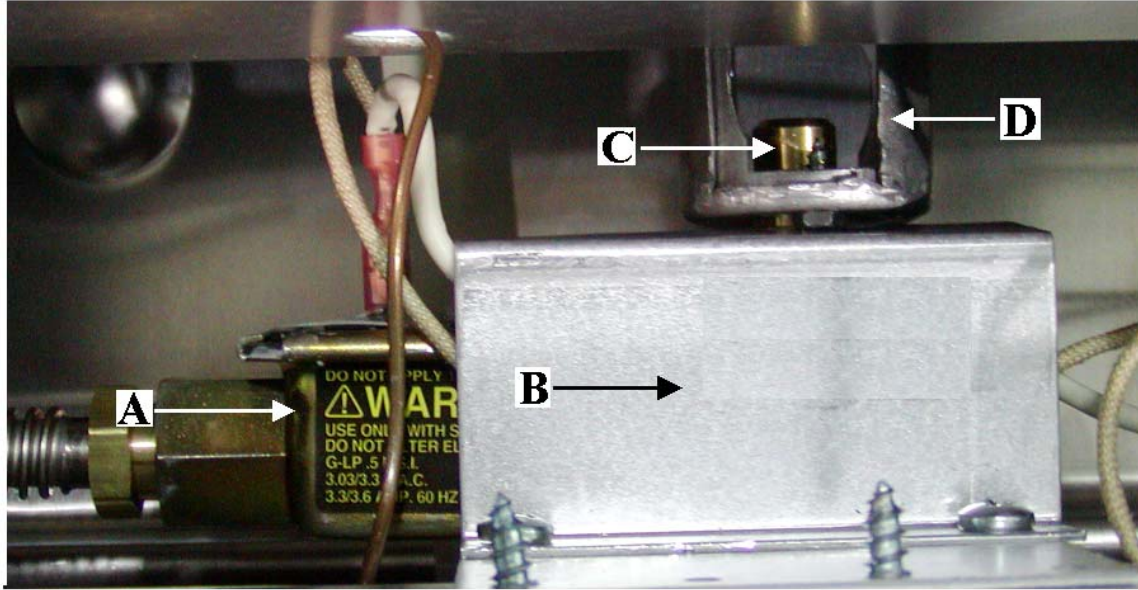

- A Griddle Gas Valve
- B Heat Shield
- C Orifice Hood
- D Air Shutter

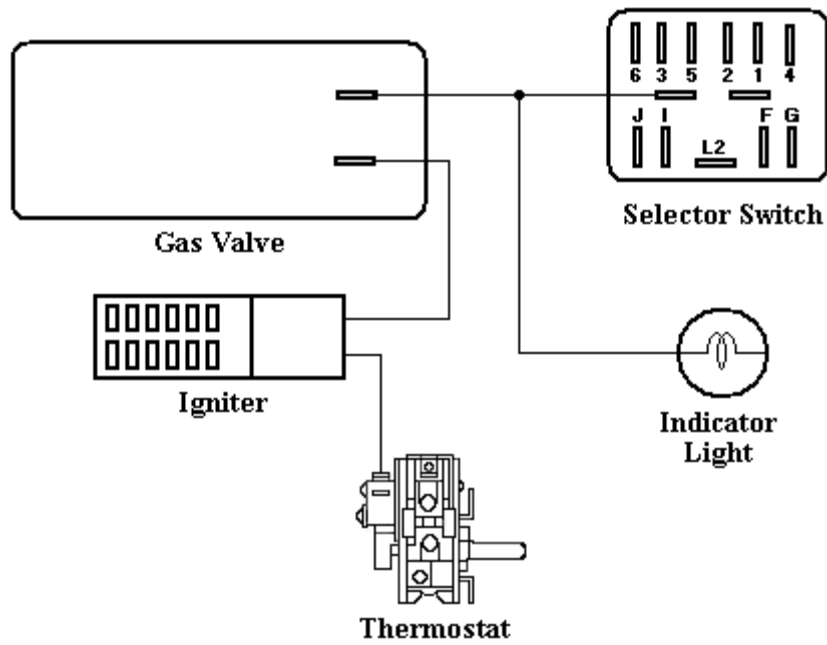

Griddle Valve and Igniter electrical circuit

Igniter System - The igniter is wired in series with the gas valve. The gas valve receives approximately 3.3 volts \pm 1v, while the igniter obtains approximately 116 volts \pm 1v.

1. Checking the igniter

A) What is the line voltage?

If line voltage is higher than normal igniter could be seeing elevated temperatures that could be effecting igniter life. If line voltage is lower than normal igniter may not be receiving enough power to bring igniter to required amperage. (Note: a lower voltage igniter has been made available to Viking)

B) What is the Room temperature Resistance (RTR) of the igniter. A new Viking igniter should read 40-400 ohms, however a used igniter may have much higher RTR and still function properly.

C) Visual Inspection when igniter is energized. Look for a crack.

NOTE: Igniter cracks are also common on tip of element as well as lower section shown above.

If Igniter is cracked, then replace that igniter only. Visually inspect other igniters in range. If igniter looks okay then;

D) Measure the amperage and voltage. Specification on New igniter is 3.4 – 3.6 amps at 116 \pm 1 Volts Note that igniter amperage decreases over life. If igniter amperage is 3.0 or above at 116 volts igniter should *not* need to be replaced. We suggest using a clamp on amp meter with resolution to .10 amps.

E) Measure opening amperage of valve. The igniter current is what operates the valve. At what amperage is the gas valve opening? Has the valve aged out of spec?

Please note that the system can take 90 seconds or more to operate. You may have to be patient to allow the gas valve to open especially when the igniter is aged and the current is lower.

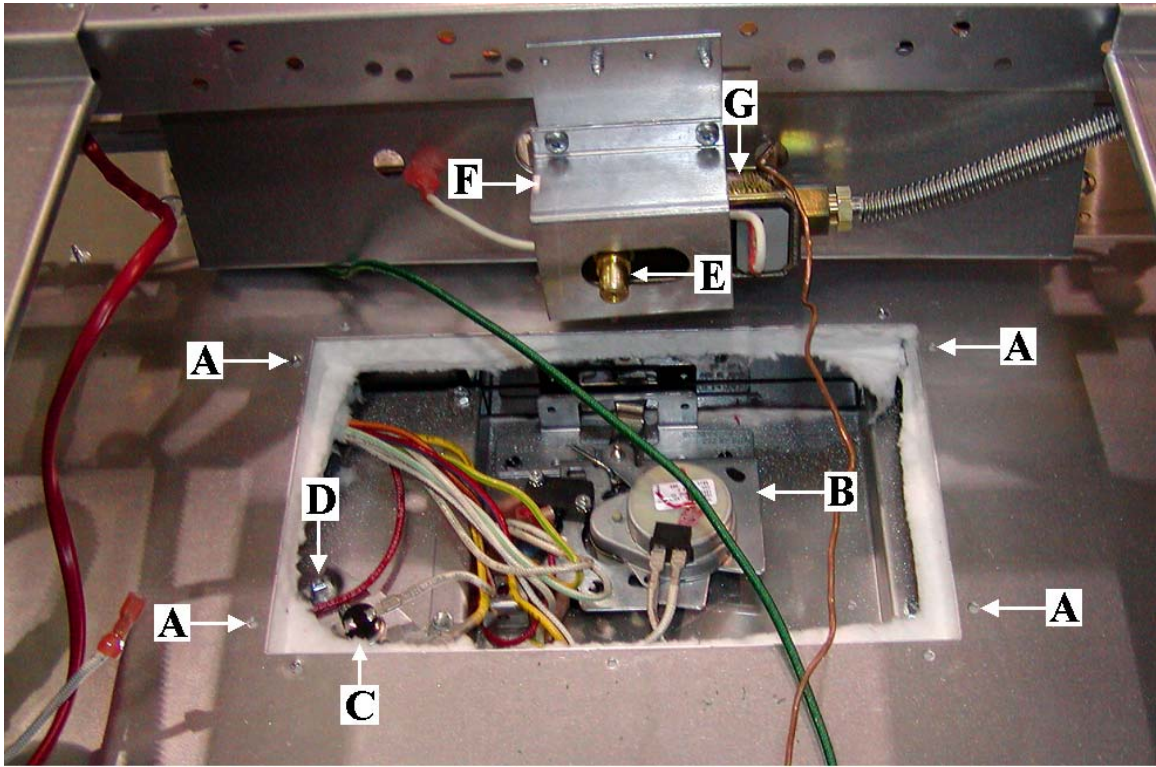

Remove screws marked (A) to gain access the door lock motor (B) and associated components, Fan Switch (C) and High Limit Switch (D).

E Orifice Hood

F Heat Shield

G Griddle Gas Valve

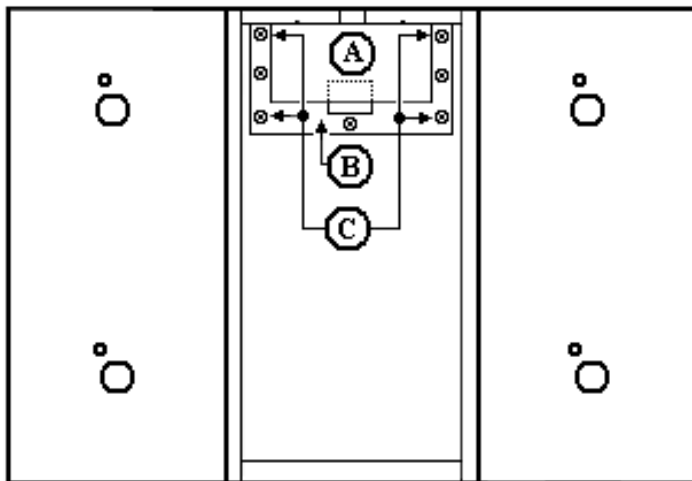

(A) SPARK MODULE COVER

(B) DOOR LOCK INSULATION BOX ASSEMBLY

(C) REMOVE SCREWS MARKED (C) TO REMOVE THE COVER

COMBUSTION OF GAS

- A. **The Meaning of Combustion** - When oxygen acts with a substance to produce large amounts of heat rapidly (and usually light), the process is called combustion or burning.
- B. **Requirements for Combustion** - Three things needed for combustion to take place are fuel, oxygen (air) and heat (temperature). All must be present. Take away any one of the three and burning will stop. Gas ignition temperature is approximately 1100 - 1200 degrees Fahrenheit.
- C. **Basic Chemistry of Combustion** - Combustion of gas is a chemical reaction between fuel gas and oxygen. The basic elements of common fuel gases are hydrogen (H) and Carbon (C). When hydrogen burns, water vapor (H₂O) is produced. Complete burning of carbon in fuel gases form carbon dioxide (CO₂). Complete combustion produces harmless carbon dioxide (CO₂) and water vapor (H₂O). **Water** is produced as a vapor in the burning of gas. If the flue products remain hot enough, water is discharged as vapor to the outside through vent system. If the flue products should become cool, as in an air conditioned room, this water vapor will condense out as a liquid on any cooler surface. The temperature at which water forms from vapor is known as the dew-point.
- D. **Controlled Combustion** - Controlled combustion takes place when fuel gas and air are supplied at proper rates to assure complete combustion (burning) of the gas in a steady flame. When a gas appliance is operating properly, burning starts at the burner ports. Gas flow is controlled by a gas orifice size and by gas pressure upstream of the orifice. Burners which have some air premixed with the gas before it passes through the BURNER PORTS are called "blue flame" burners. This air added to the gas is called primary air. The rest of the air required for complete combustion is supplied to the burner flames in the COMBUSTION CHAMBER and is called SECONDARY AIR. **Adjustments** of gas rate and primary air provide the key to obtaining stable, blue flames on the burner using primary air. AIR SHUTTERS or other devices provide control of primary air. Proper amounts of primary and secondary air are needed for quiet and efficient appliance operation and for complete combustion of the gas. Size of the inlet openings and flue outlets control secondary air flow.
- E. **Explosive Combustion** - An explosion is simply very rapid burning which is not under control.
- F. **Limits of Flammability** - Not all air-gas mixtures will burn. Mixtures with zero to four percent natural gas in air are too lean to burn. Mixtures of four to fourteen percent natural gas in air can burn with a controlled flame. **Flammability** Limits are of interest to those dealing with problems and everyday operations in the gas industry. For example consider, FLASHTUBE ignition of rangetop burners. A gas-air mixture from the burner head passes through a charge port into the open end of the flashtube. This mixture is too rich to burn without secondary air, but some air also enters the flashtube at the entrance. The additional air causes the mixture to become leaner to a composition that is flammable. When the mixture travels down the tube to point of ignition, the flame will carry back from the lighter to the charge port and light the gas at the burner. If the mixture in the flashtube has too much gas (too rich) or has too much air (too lean), the burner will not light. **Flammability** Limits also enter the picture when primary air adjustments are made on burners. For example, Infra-red (radiant) burners usually operate with about 100 percent primary air. In other words the gas air mixture in the burner head contains all the air ideally required for complete combustion. If too much primary air is used, the mixture may become too lean and fall outside the lower flammability limit and it will not burn on the burner surface. **Unburned** gas should not be allowed to collect in combustion chambers or confined spaces because gas-air mixture within the flammability limits will explode if ignited.
- G. **Incomplete Combustion - Causes and Effects** To obtain complete combustion enough air must be supplied to the process. This air must have a Reasonably normal oxygen content. Complete burning of gas produces harmless carbon dioxide and water vapor. If not enough air is supplied other products will form. Some of these products are harmful, especially carbon monoxide.

GAS CONNECTION

All gas connections must be made according to national and local codes. This gas supply (service) line must be the same size or greater than the inlet line of the appliance. This range uses a ½" NPT (Sch 40) inlet. Sealant on all pipe joints must be resistive to LP gas.

1. **Manual Shutoff Valve:** This installer supplied valve must be installed in the gas service line ahead of the appliance in the gas stream and in a position where it can be reached quickly in the event of an emergency. In **Massachusetts** a "T" handle type manual gas valve must be installed in the gas supply line to this appliance.
2. **Pressure Regulator:**
 - a) All heavy duty, commercial type cooking equipment must have a pressure regulator on the incoming service line for safe and efficient operation, since service pressure may fluctuate with local demand. External regulators are not required on this range, because a regulator is built into each unit at the factory. Under no condition bypass this built-in regulator.
 - b) Any conversion required must be performed by your dealer or a qualified licensed plumber or gas service company. Please provide the service person with this manual before work is started on the range. (Gas conversions are the responsibility of the dealer or end user.)
 - c) This range can be used with Natural or LP/Propane gas. It is shipped from the factory adjusted for use with natural gas. The orifice hoods must be screwed snug when LP/Propane gas is used. (See LP conversion.)
 - d) Manifold pressure should be checked with a manometer, natural gas requires 5.0" WCP and LP/Propane requires 10.0" WCP. Incoming line pressure upstream from the regulator must 1" WCP higher than the manifold pressure in order to check the regulator. The regulator on this range can withstand a maximum input pressure of ½ PSI (14.0" WCP). If the line pressure is in excess of that amount, a step-down regulator will be required.
 - e) The appliance, its individual shut-off valve, and pressure regulator must be disconnected from the gas supply piping system during any pressure testing of that system at pressures in excess of ½" psig.
 - f) The appliance must be isolated from the gas supply piping system by closing its individual manual shut-off valve during any pressure testing of the gas supply piping system at test pressures equal to or less than ½" psig.
3. **Flexible Connections:**
 - a) If the unit is to be installed with flexible couplings and/or quick disconnect fittings, the installer must use a heavy duty, AGA design-certified commercial flexible connector of a least ½" (1.3 cm) ID NPT (with suitable strain reliefs) in compliance with ANSI Z21.41 and Z21.69 standards.
 - b) **In Massachusetts:** This unit must be installed with a 36" (3 foot) long flexible gas connector.
 - c) **In Canada:** CAN 1-6, 10-88 metal connectors for gas appliance and CAN 1-6.9 M79 quick disconnect device for use with gas fuel.

CAUTION: Leak testing of the appliance shall be conducted according to the manufacturer's instructions. Before placing the oven into operation, always check for leaks with a soapy water solution or other acceptable method. **DO NOT USE AN OPEN FLAME TO CHECK FOR LEAKS.**

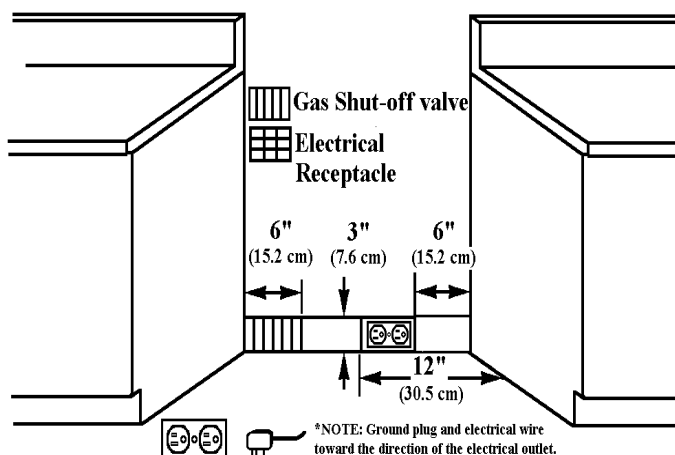

A properly grounded horizontally mounted electrical receptacle should be installed no higher than 3" (7.6 cm) above the floor, no less than 6" (15.2 cm) and not more than 12" (30.5 cm) from the right side (facing product). Check all local code requirements.

An agency approved, properly sized manual shut-off valve should be installed no higher than 3" (7.6 cm) from the left side (facing product). To connect gas between shut-off valve and regulator, use agency approved, properly sized flexible conduit or rigid pipe. Check all local code requirements.

Add a street elbow to the input gas line at the rear of the range to keep the flex line from having to bend over the edges of the back panel. The LP orifices are located on the inlet supply line.

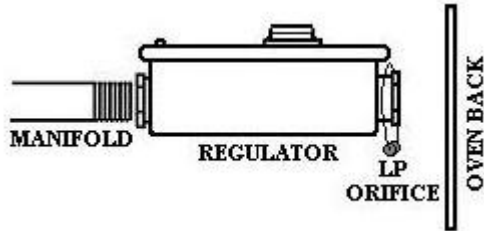

Illustrated below is the gas flow pattern from the manifold to the burner head. The necessary part numbers are listed for your convenience when ordering the flex tubing for the different lengths. The part numbers for the fixed orifices, Nat or LP, are also listed. Each burner is rated at 15,000 BTU's, NAT Gas and 13,500 BTU's on LP/Propane Gas.

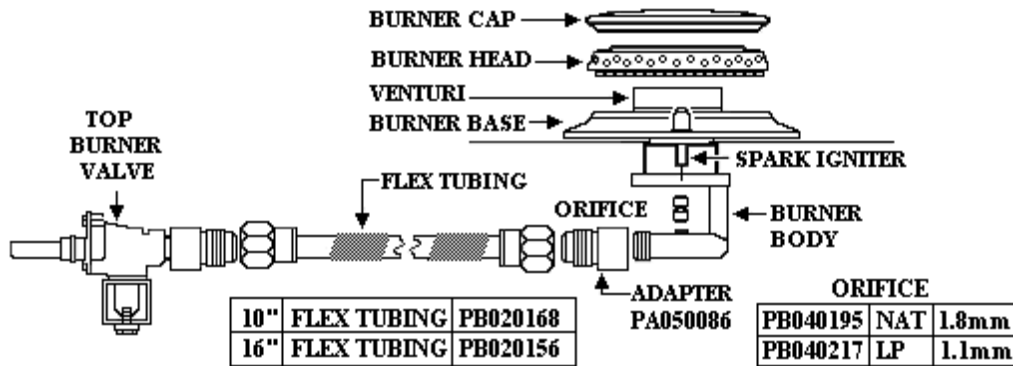

Natural to LP/Propane Conversion (For Sealed Burners)

This product is manufactured and adjusted for operation with natural gas as shipped from the factor. CAUTION: Before proceeding with conversion, turn off gas supply to the appliance and disconnect the electrical power.

To operate with LP/ Propane gas, the following adjustment should be made:

1. Remove the surface grates.
2. Remove the burner cap (item #1) and the burner head (item #2) by lifting up.
3. Remove the venturi (item #3).
4. Use a 5/16" (0.9cm) socket or nut driver to remove orifice (item #4) and replace it with LP orifices located next to the pressure regulator. Save the natural gas orifice for future use.
5. Replace the venturi (item #3) and hand tighten. Replace the burner head (item #2), the burner cap (item #1) and the surface grates.
6. To convert surface, griddle, and grill burners to LP/Propane, turn the burner orifice hoods clockwise until they become snug against the internal LP/Propane pin orifice.
7. A pressure regulator is located in the left rear corner of the burner box. Convert the regulator by removing the cap marked "Nat" and reverse it to read "LP". Be sure not to disturb or remove the spring beneath the cap.
8. Manifold pressure should be checked with a manometer. LP/Propane requires 10.0 W.C.P. Incoming line pressure upstream from the regulator must be 1" W.C.P. higher than the manifold pressure.

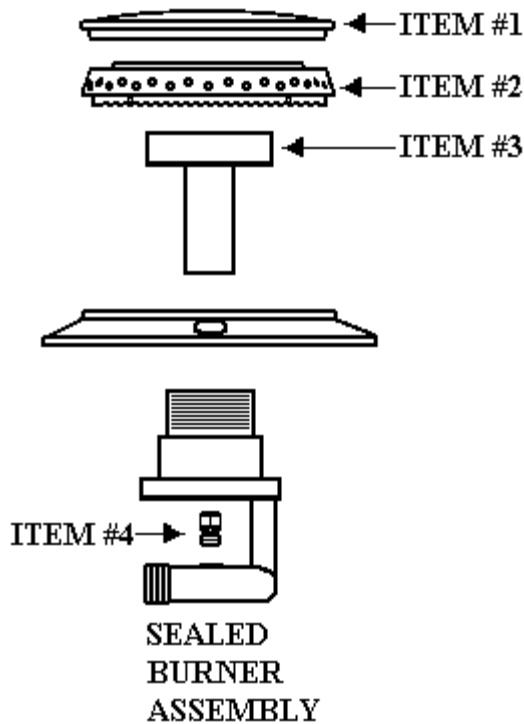

ELECTRICAL CONNECTION

Use a 3 - wire power supply cord kit rated for 30 amps - 125/250 volts for Models VDSC and VERT or 50 amps - 240 volts for Model VESC with closed loop terminals and marked for use with ranges. Where local codes do not permit grounding through neutral, use a 4 - wire power supply cord. The cord or conduit must be secured to the range with the strain relief bracket. The electrical connection is made at the terminal block, which is located behind the access door on the back of the range.

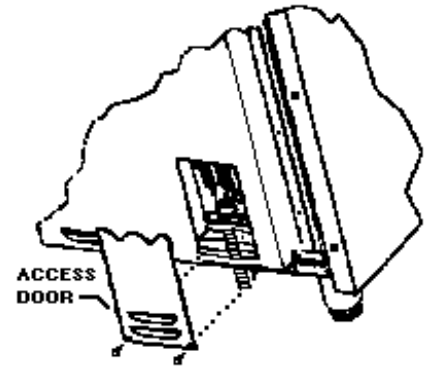

3 - Wire Power Supply Cord

1. Remove access door.
2. Remove supply cord strain relief bracket and 3 supply cord mounting screws on the terminal block.
3. Feed supply cord up through the hole in the bottom of range back.
4. Attach the line #1 (red) and line #2 (black) leads to the outside terminals and the neutral wire (white) to the center terminal on the terminal block.
5. Reattach supply cord strain relief bracket over supply cord, pushing supply cord up toward terminal block to relieve strain before tightening.
6. Reattach access door.

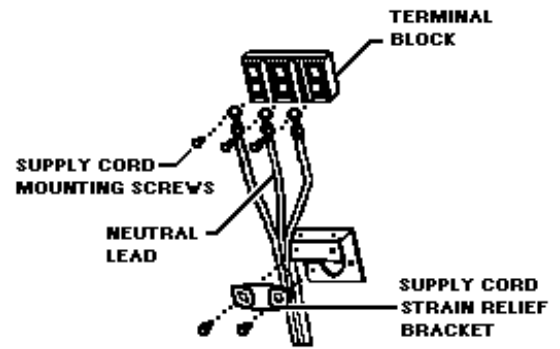

4 - Wire Power Supply Cord

1. Remove access door.
2. Remove supply cord strain relief bracket and 3 supply cord mounting screws on the terminal block.
3. Remove grounding screw; cut-off and discard ground strap.
4. Feed supply cord up through hole in the bottom of the range back.
5. Attach the ground lead (green) with the ground screw that was removed in step #3.
6. Attach the line #1 (red) and line #2 (black) leads to the outside terminals and the neutral wire (white) to the center terminal on the terminal block..
7. Reattach supply cord strain relief bracket over supply cord, pushing supply cord up towards terminal block to relieve strain before tightening.
8. Reattach access door.

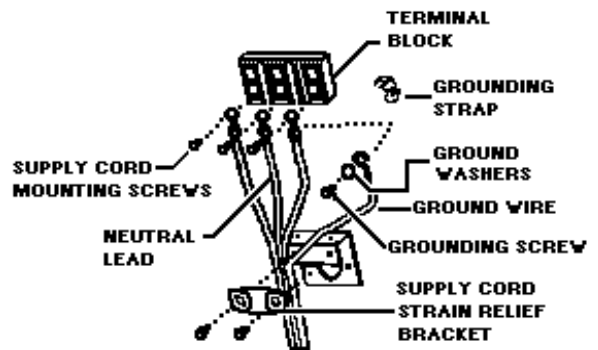

ELECTRICAL CONNECTIONS WITH CONDUIT

Use ½" trade size conduit with a conduit clamp, 12 AWG /600 volt copper conductor colored red for line # 1 and black for line # 2 and 14 AWG /600 volt copper conductor colored white for neutral with closed loop terminals marked for use with ranges. Where local codes do not permit grounding through neutral, use a green 12 AWG copper conductor as directed in the 4 - wire connector directions. The conduit must be secured to the range with the strain relief bracket. The electrical connection is made at the terminal block which is located behind the access door on the back of the range.

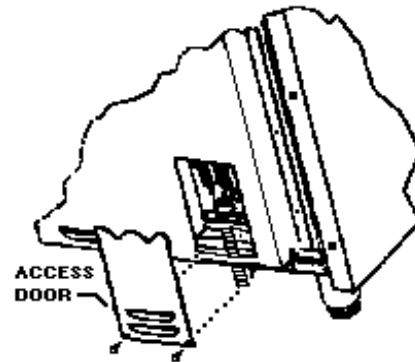

3 - Wire Power Connection

1. Remove access door.
2. Remove strain relief mounting angle and reattach as shown.
3. Feed ½" trade size conduit through the hole in the bottom of the range back and secure to the strain relief bracket with a conduit clamp.
4. Feed line #1 (red 12 AWG / 600v copper conductor), line #2 (black 12 AWG / 600v copper conductor), and neutral (white 14 AWG / 600v copper conductor) through conduit and attach closed loop terminals marked for use with ranges.
5. Remove 3 mounting screws and attach line #1 (red) to left terminal, line #2 (black) to the right terminal, and the neutral wire (white) to the center terminal.
6. Reattach the access door.

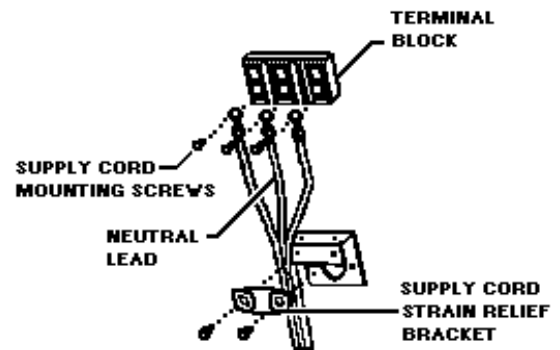

4 - Wire Power Connector

1. Remove access door.
2. Remove strain relief mounting angle and reattach as shown.
3. Feed 1½" trade size conduit through the hole in the bottom of the range back and secure to the strain relief bracket with a conduit clamp.
4. Feed line #1 (red 12 AWG / 600v copper conductor), line #2 (black 12 AWG / 600v copper conductor), neutral (white 14 AWG / 600v copper conductor), and a grounding wire (green 12 AWG copper conductor) through conduit and attach closed loop terminals marked for use with ranges. (Terminal is not required on grounding wire if used with ground washer).
5. Remove 3 mounting screws and green grounding screw. Cut-off and discard ground strap. Attach line #1 (red) to the left terminal, line #2 (black) to the right terminal, the neutral wire (white) to the center terminal and the copper ground wire to the green grounding screw using the ground washer.
6. Reattach the access door.

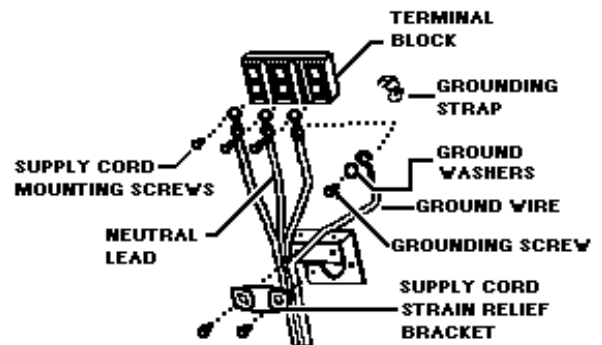

SURFACE BURNER SPARK MODULE

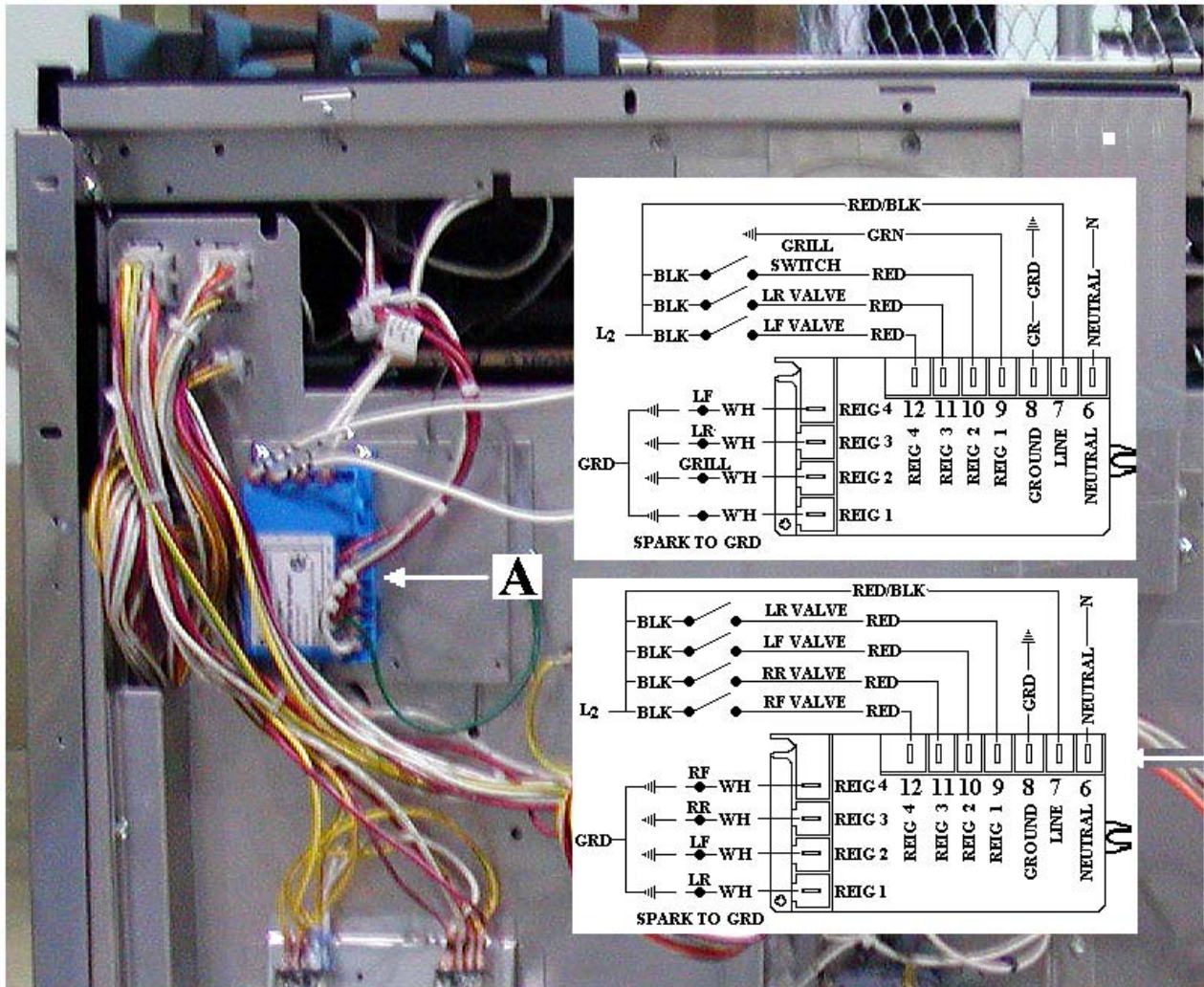

The surface burner spark module is located on the rear of the unit, see above for location. Check your module for the correct wiring and color codes.

36" PRE-HEAT BOARD SINGLE OVEN

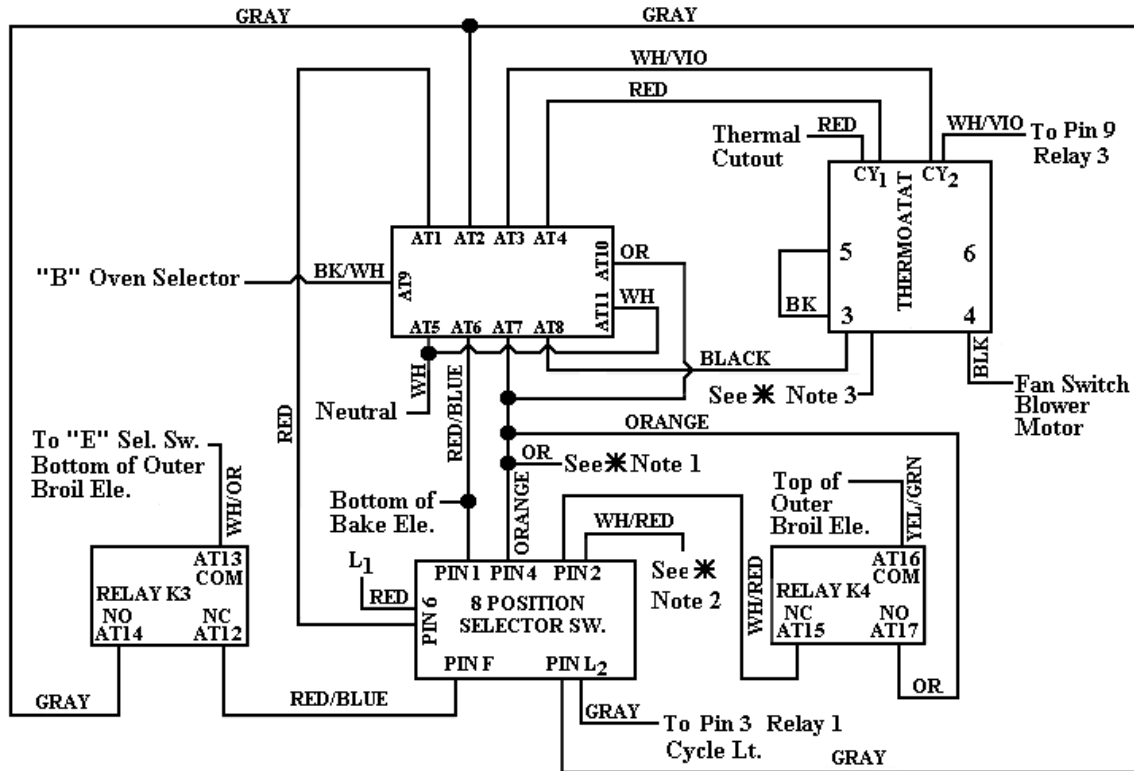
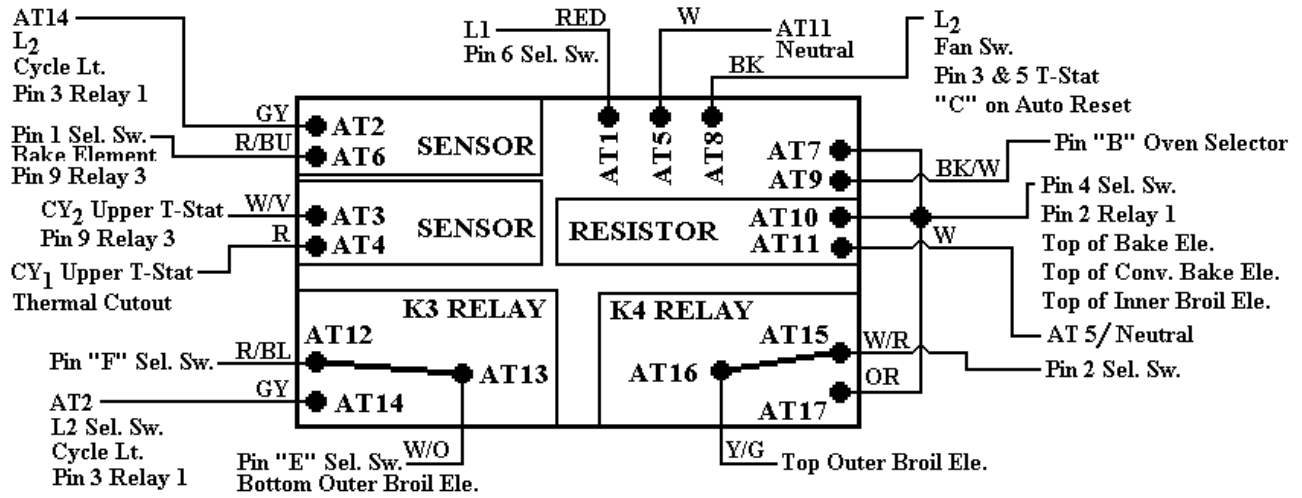

* Note 1 Pin 2 Relay 1
Top of Bake Ele.
Top of Conv. Bake Ele.
Top of Inner Broil Ele

* Note 2 Top of Outer Broil Ele.
* Note 3 Fan Sw.
T-Stat 5 & 3
"C" Auto Reset

COMPONENT CONTACTS FOR VDSC367

PRE-HEAT BOARD

POSITION	K3		K4	
	N.O.	NC.	N.O.	NC.
OFF	O	X	O	X
START IN ANY BAKE POSITION	X	O	X	O
AFTER FIRST CYCLE	O	X	O	X

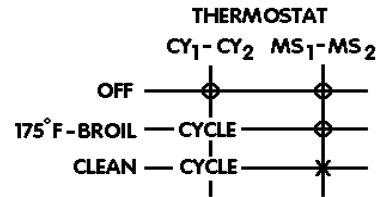
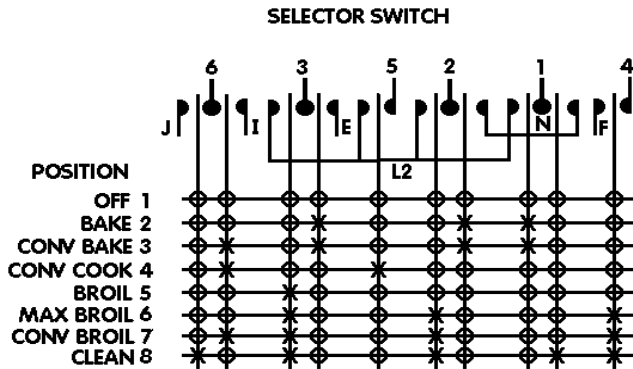

*DELAYED 30 SECONDS AFTER T-STAT MS₁ - MS₂ CONTACT AND SELECTOR 8 - J CONTACTS CLOSES

O = OPEN X = CLOSED

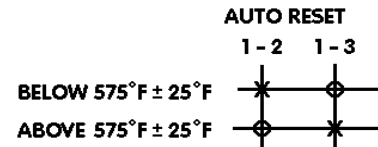

O = OPEN X = CLOSED

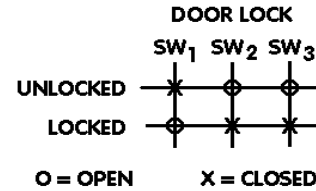

O = OPEN X = CLOSED

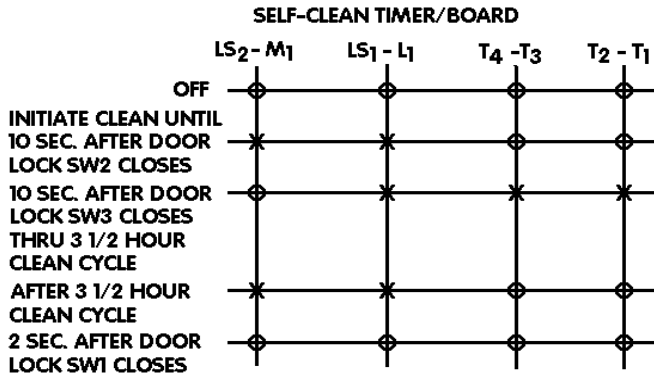

FOR CONNECTION TO THE FACTORY INSTALLED TERMINAL BLOCK USE COPPER CONDUCTORS ONLY

WARNING

THIS UNIT MUST BE GROUNDED. SEE INSTALLATION INSTRUCTIONS FOR PROPER GROUNDING PROCEDURES

CAUTION

LABEL ALL WIRES PRIOR TO DISCONNECTION WHEN SERVICING CONTROLS. WIRING ERRORS CAN CAUSE IMPROPER AND DANGEROUS OPERATION. VERIFY PROPER OPERATION AFTER SERVICING.

NOTE: TRAILERS OR STRIPES WILL BE THE SECOND COLOR IN A COLOR COMBINATION

WIRING DIAGRAM VDSC367 (36")

NOTE: 30" RANGE BAKE ELEMENT: 2750W
36" RANGE BAKE ELEMENT: 3250W

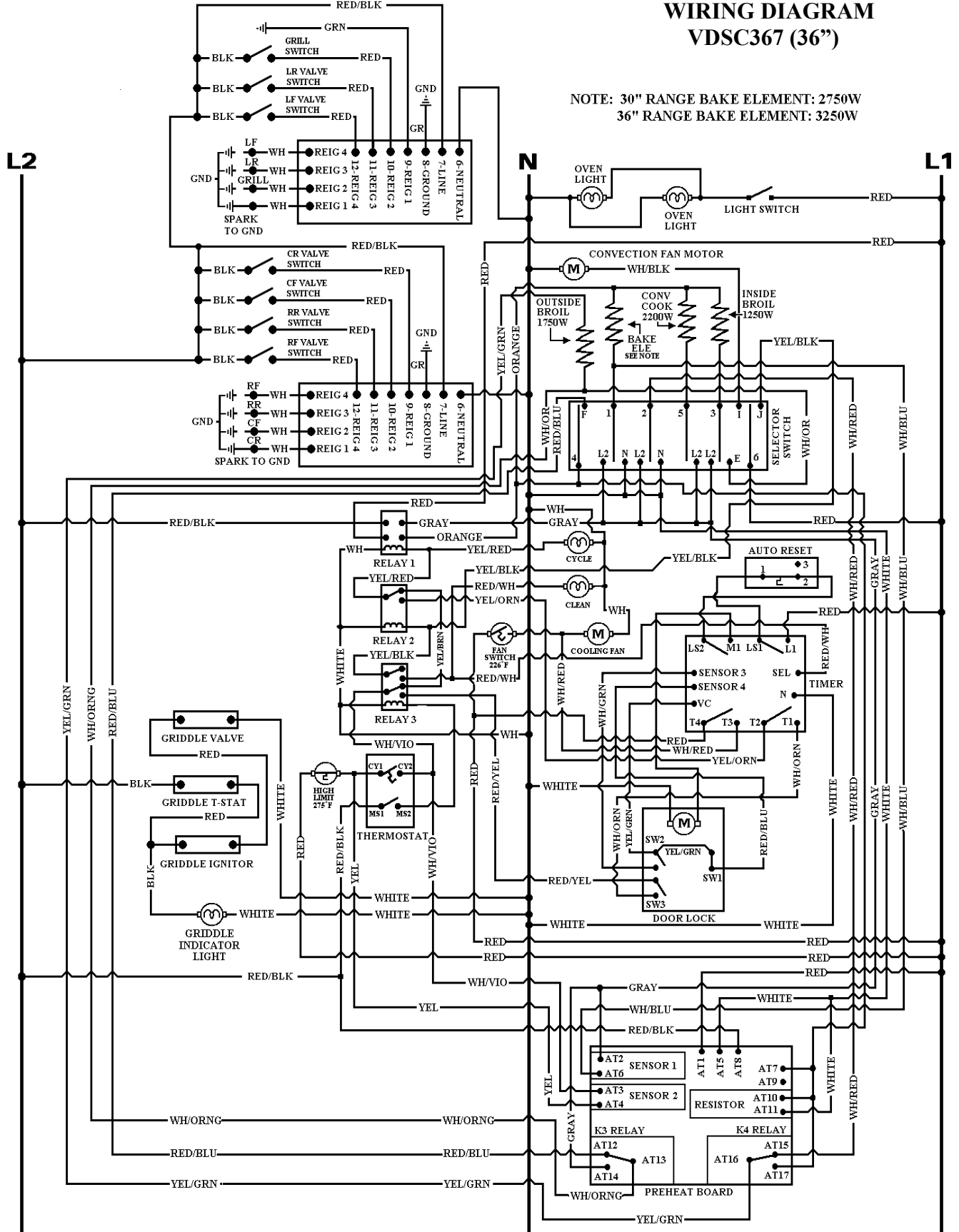

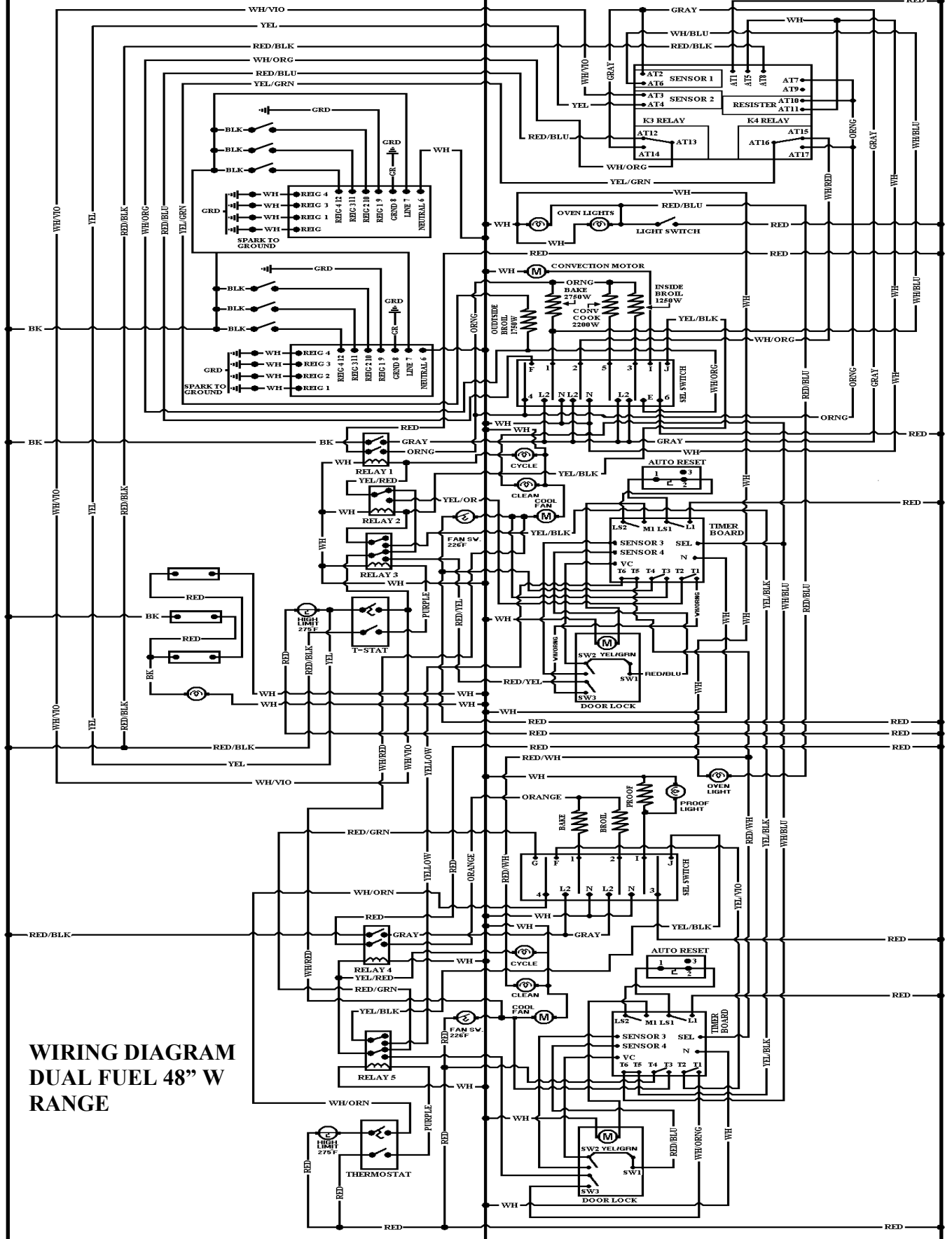

**WIRING DIAGRAM
DUAL FUEL 48" W
RANGE**

COMPONENT CONTACTS FOR VDSC487

SELECTOR SWITCH (LH OVEN)

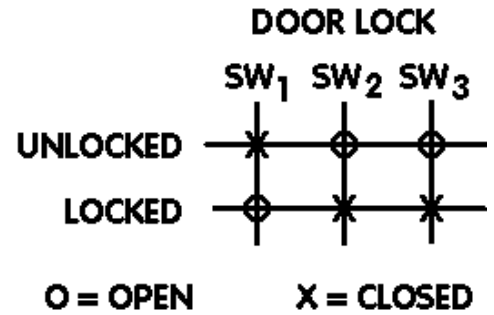
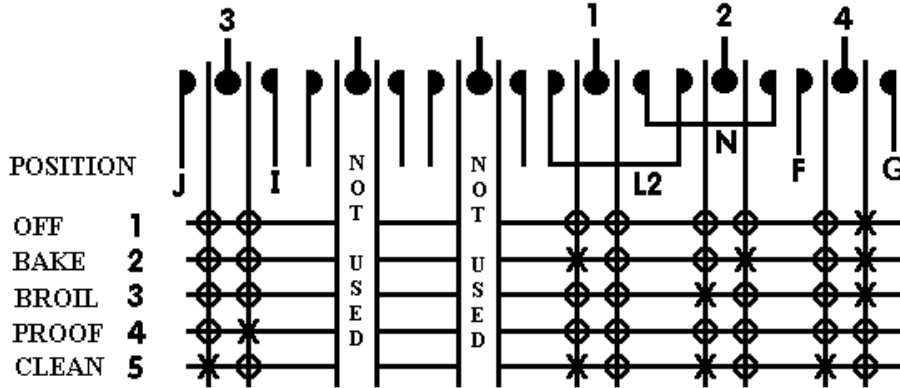

SELECTOR SWITCH

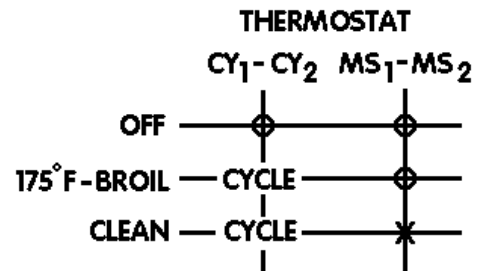
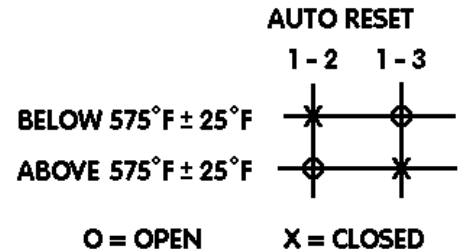
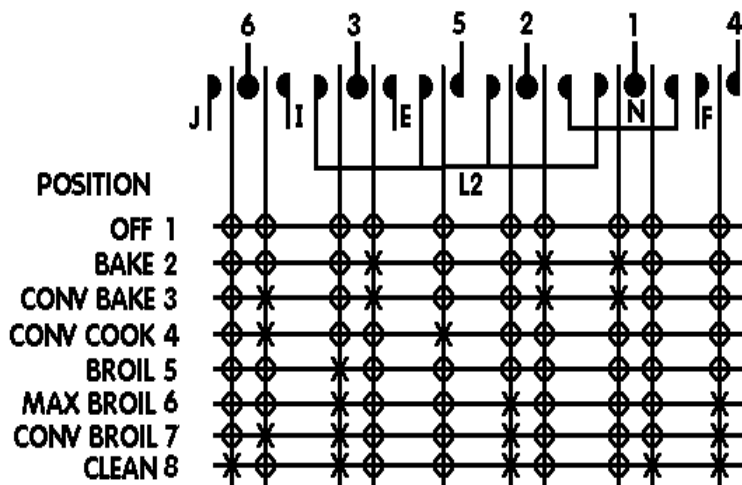

*DELAYED 30 SECONDS AFTER T-STAT MS₁ - MS₂ CONTACT AND SELECTOR 8 - J CONTACTS CLOSES

O = OPEN X = CLOSED

SELF-CLEAN TIMER/BOARD

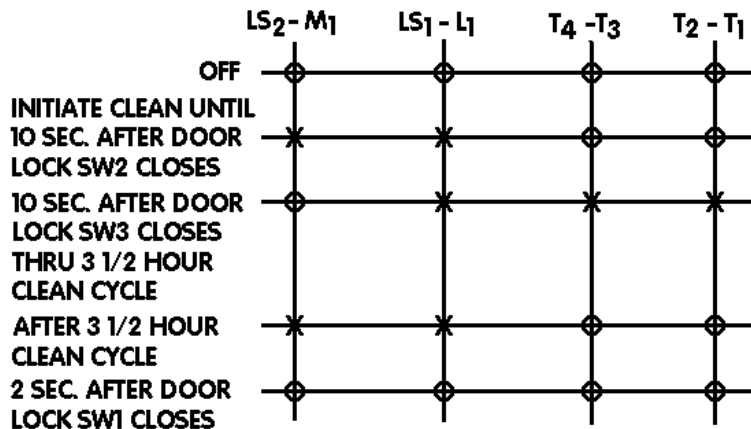

POSITION
OFF
JY BAKE POSITION
AFTER FIRST CYCLE

PRE-HEAT BOARD

POSITION	K3		K4	
	N.O.	NC.	N.O.	NC.
OFF	O	X	O	X
JY BAKE POSITION	X	O	X	O
AFTER FIRST CYCLE	O	X	O	X

VDSC367 /487 BAKE

Bake Initial Cycle with Pre-Heat

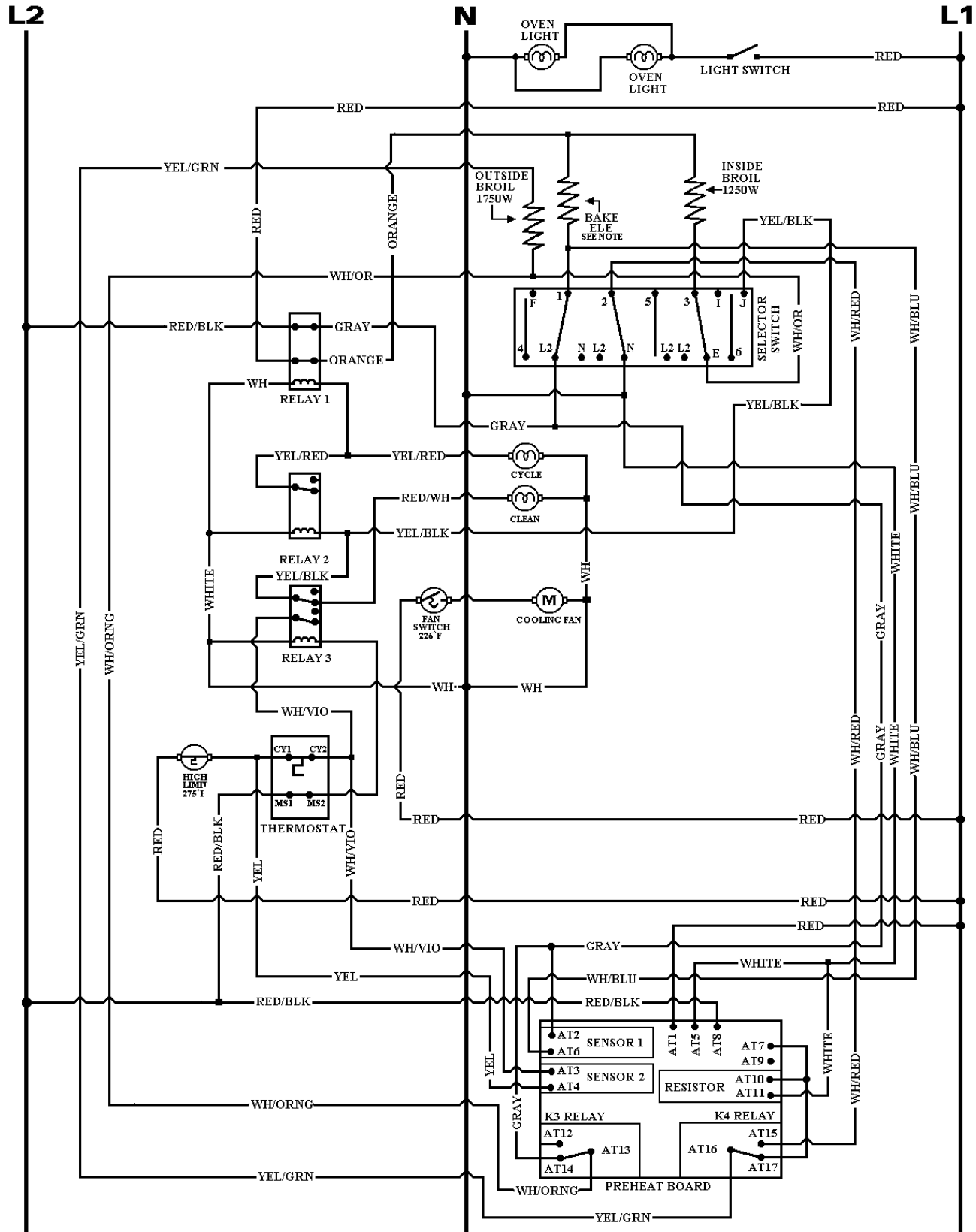

VDSC367 / 487 BAKE OVEN Convection Bake

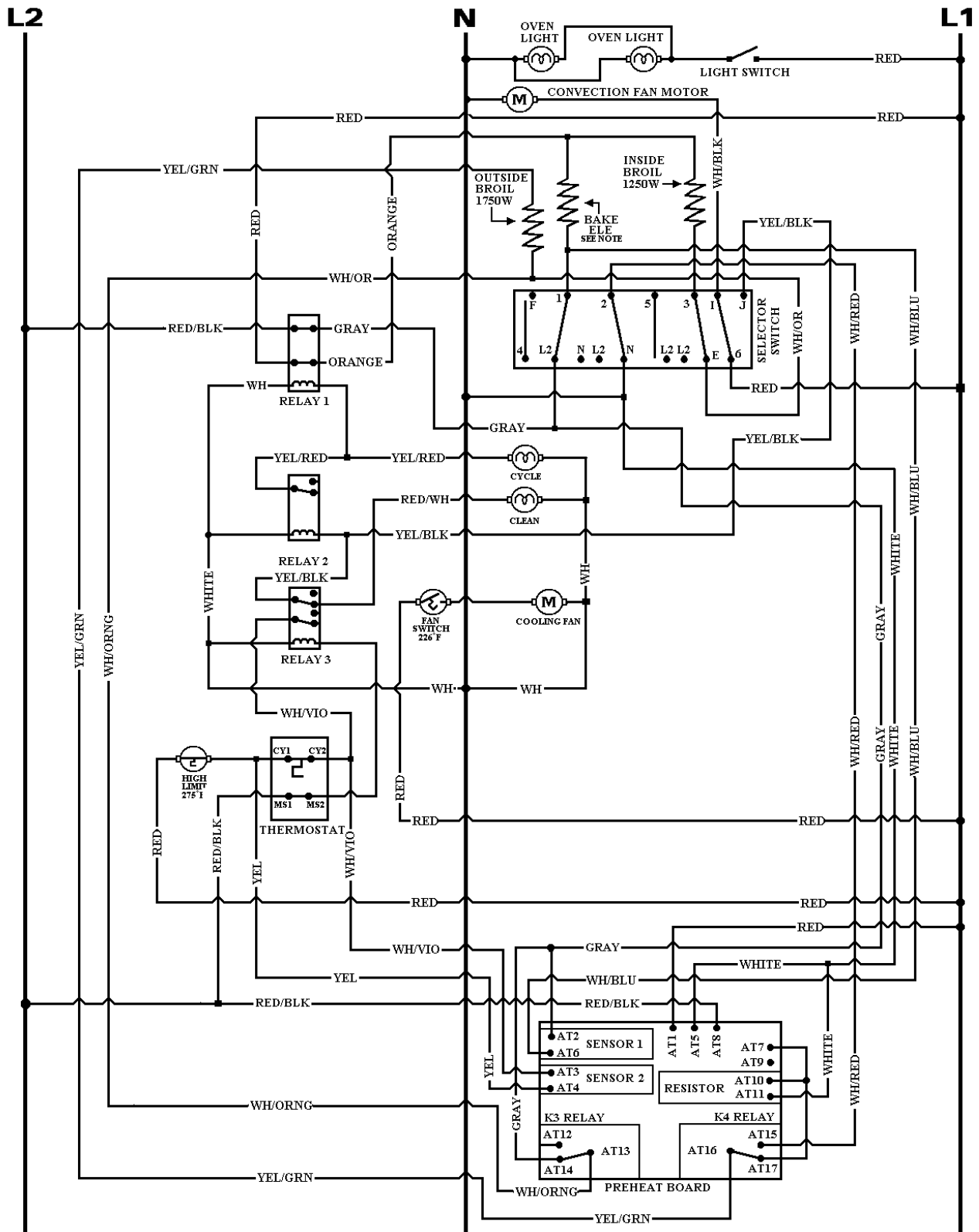

VDSC367 / 487 BAKE OVEN Convection Cook

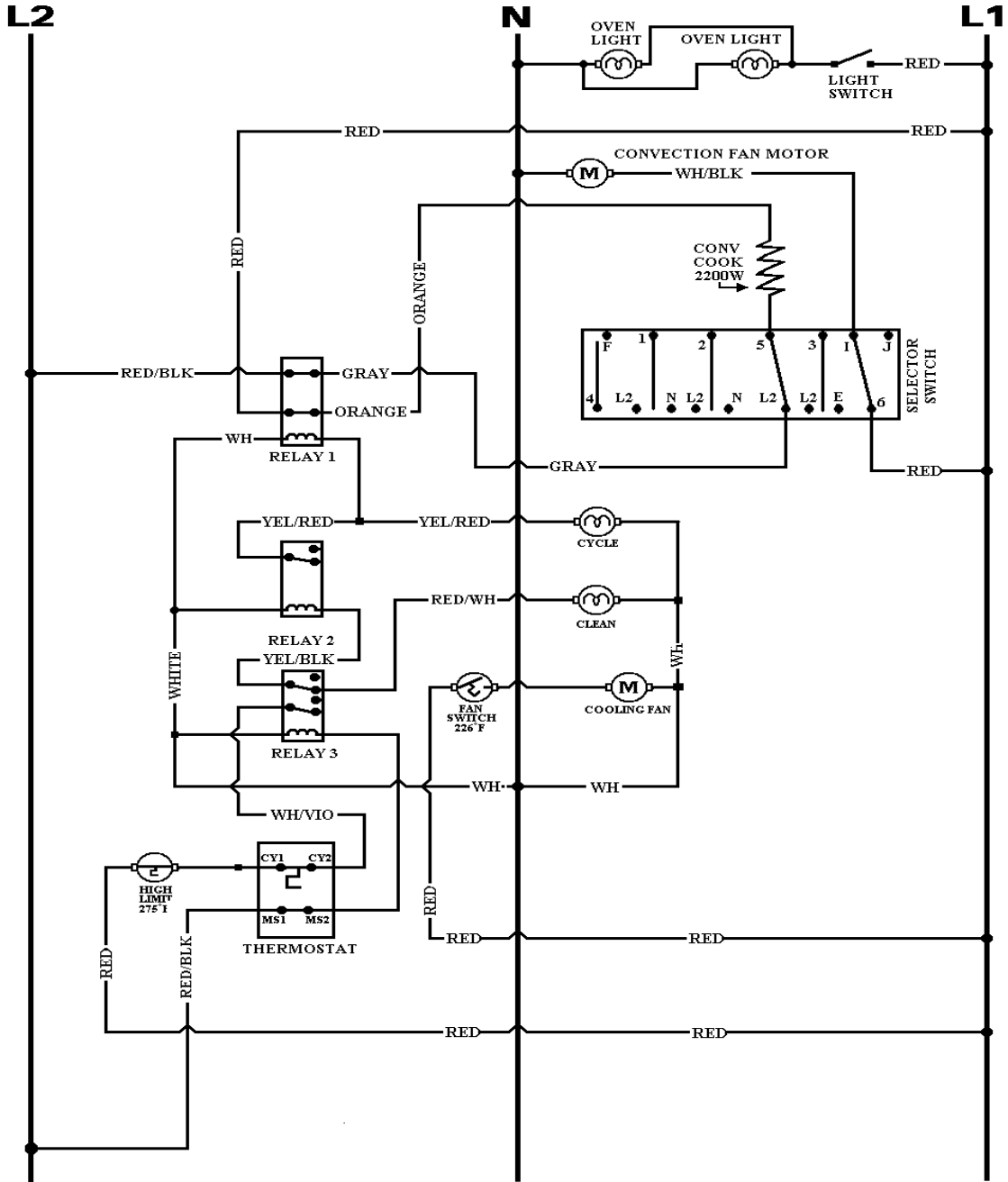

VDSC367 / 487 BAKE OVEN Broil

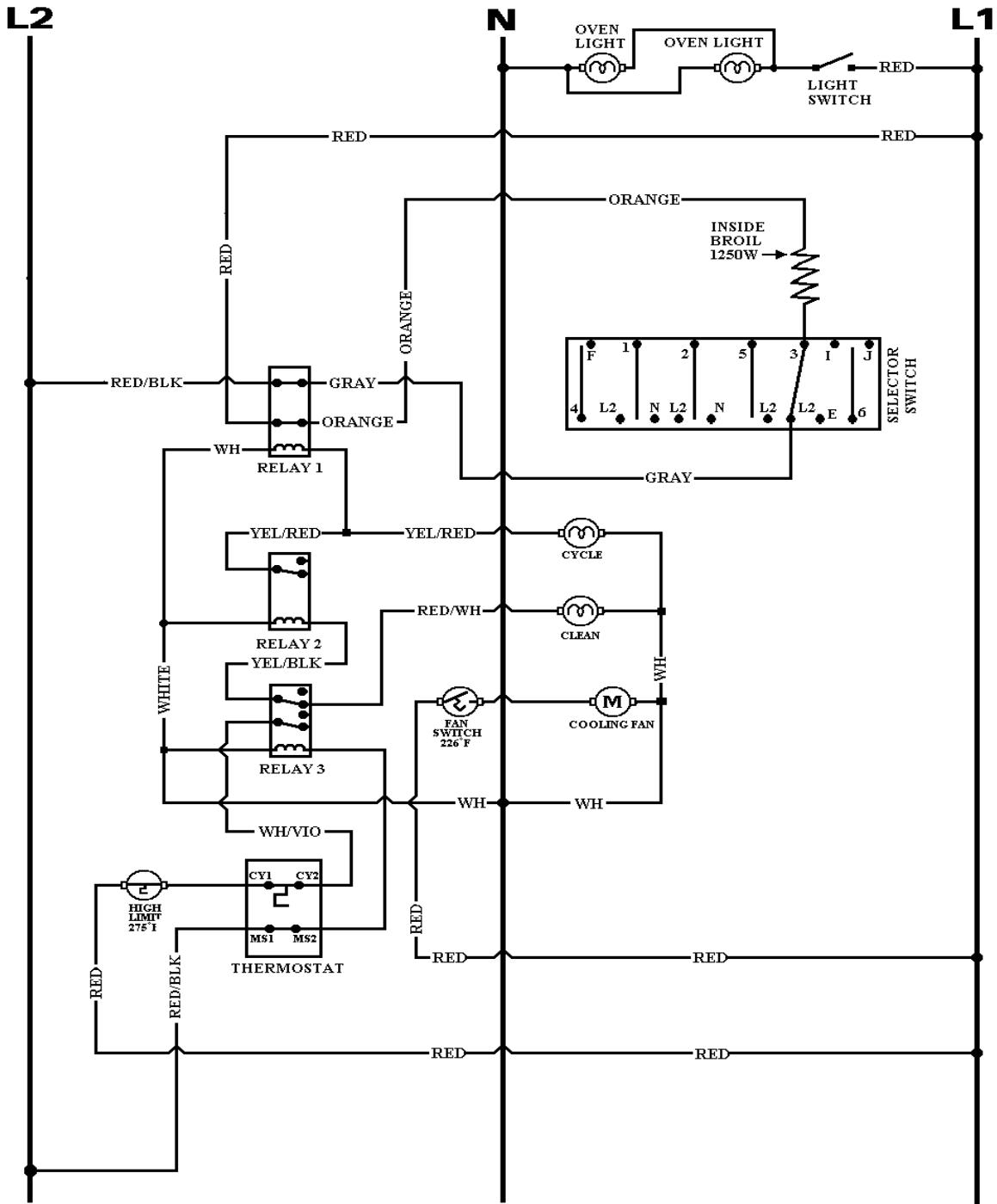

VDSC367 / 487 BAKE OVEN Maxi Broil

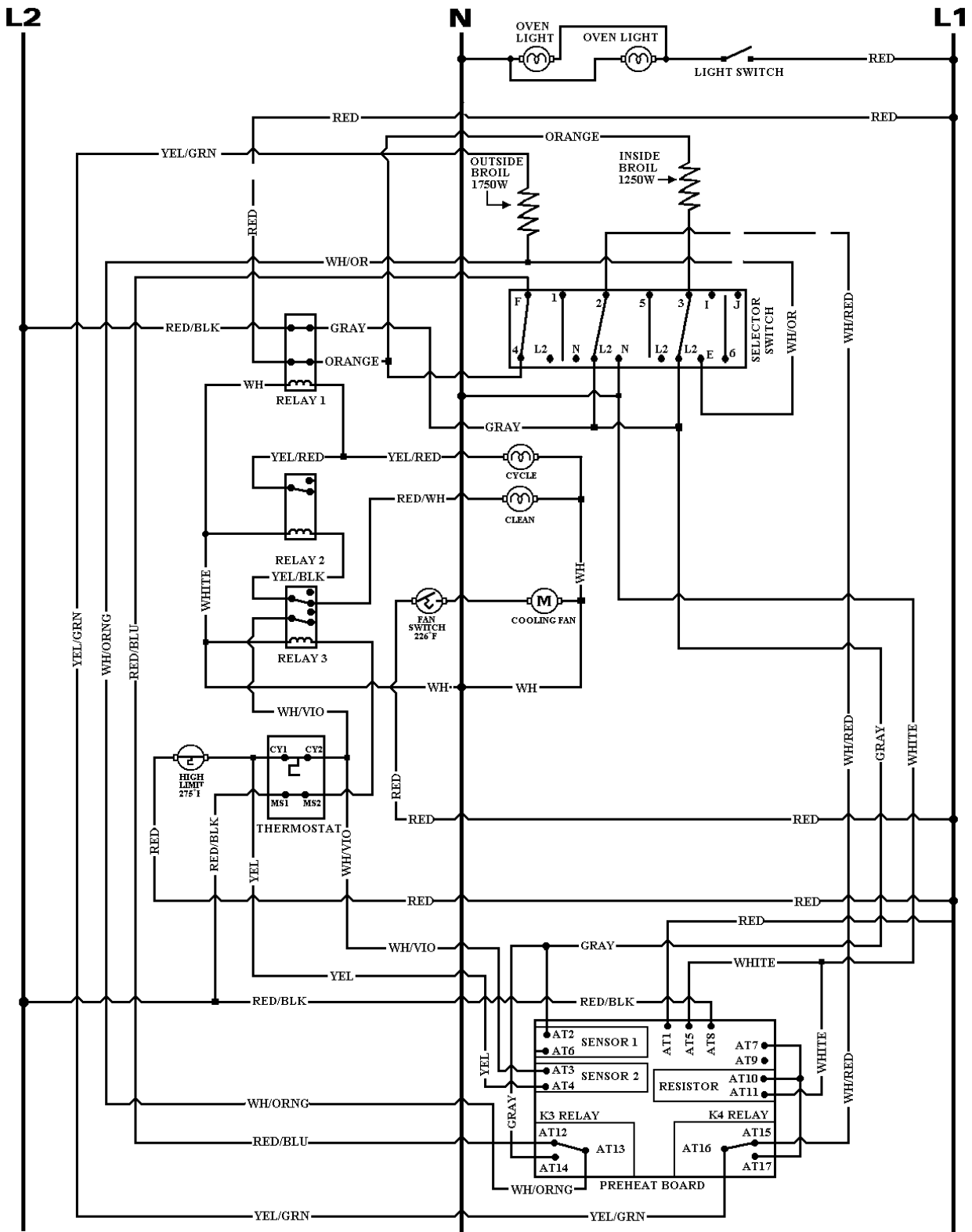

VDSC367 / 487 BAKE OVEN Convection Broil

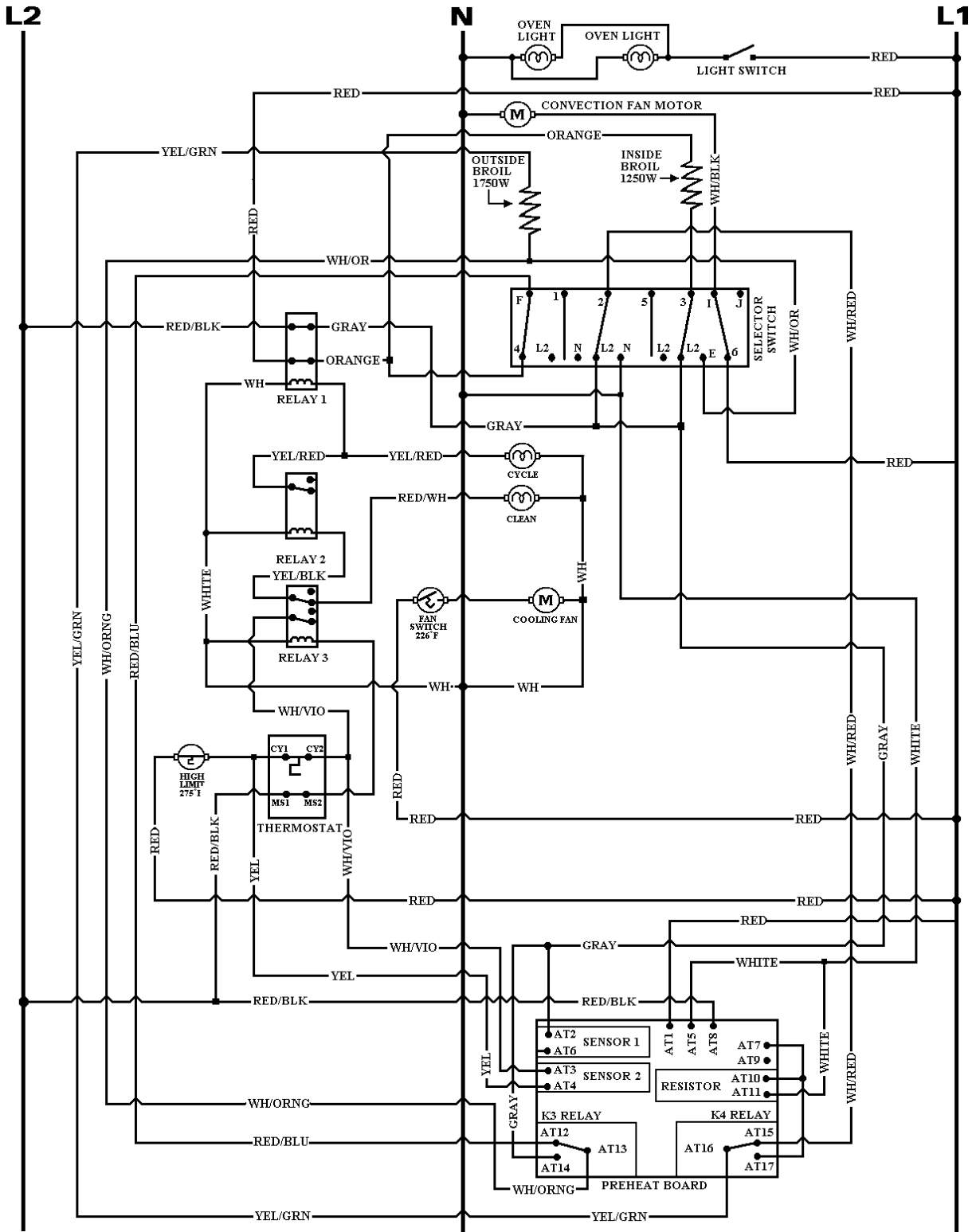

VDSC367 / 487 BAKE OVEN SELF-CLEAN

- 10 seconds after the signal to **Sensor #3**, switch **LS2-M1** is opened, stopping the door lock motion and switches **T1-T2**, and **T3-T4** which switches **Relay #1**, powering the **Cooling Fan**, which closes **Relay #1** powering the **inside and outside Broil Elements** to 208/240V and the **Bake Element** to 120V.

- **Auto Reset** switches to 1-3 which turns **Door Lock indicator light** on and disables **Door Lock Motor** circuit.

- **Timer** switches **T3-T4**, **T1-T2** open, turning off the **Cooling Fan**, which will then be powered at 120V by the **Fan Limit Switch** when needed, and opening the circuit to **Relay #1** which disables the Heating Elements. **Switch LS2-M1** closes to power the **Door Lock Motor**.

- **Auto Reset** switches 1-2 closed allowing the **Door Lock Motor** to operate and turning the door lock light off. The **Door Lock Motor** operates until 2 seconds after **Sensor 4** is signaled the **VC** that the **Door Lock SW1** has been closed mechanically by the door lock bolt. The **Door Lock / Timer** switches **LS2-M1** and **LS1-L1** open and the timer resets.

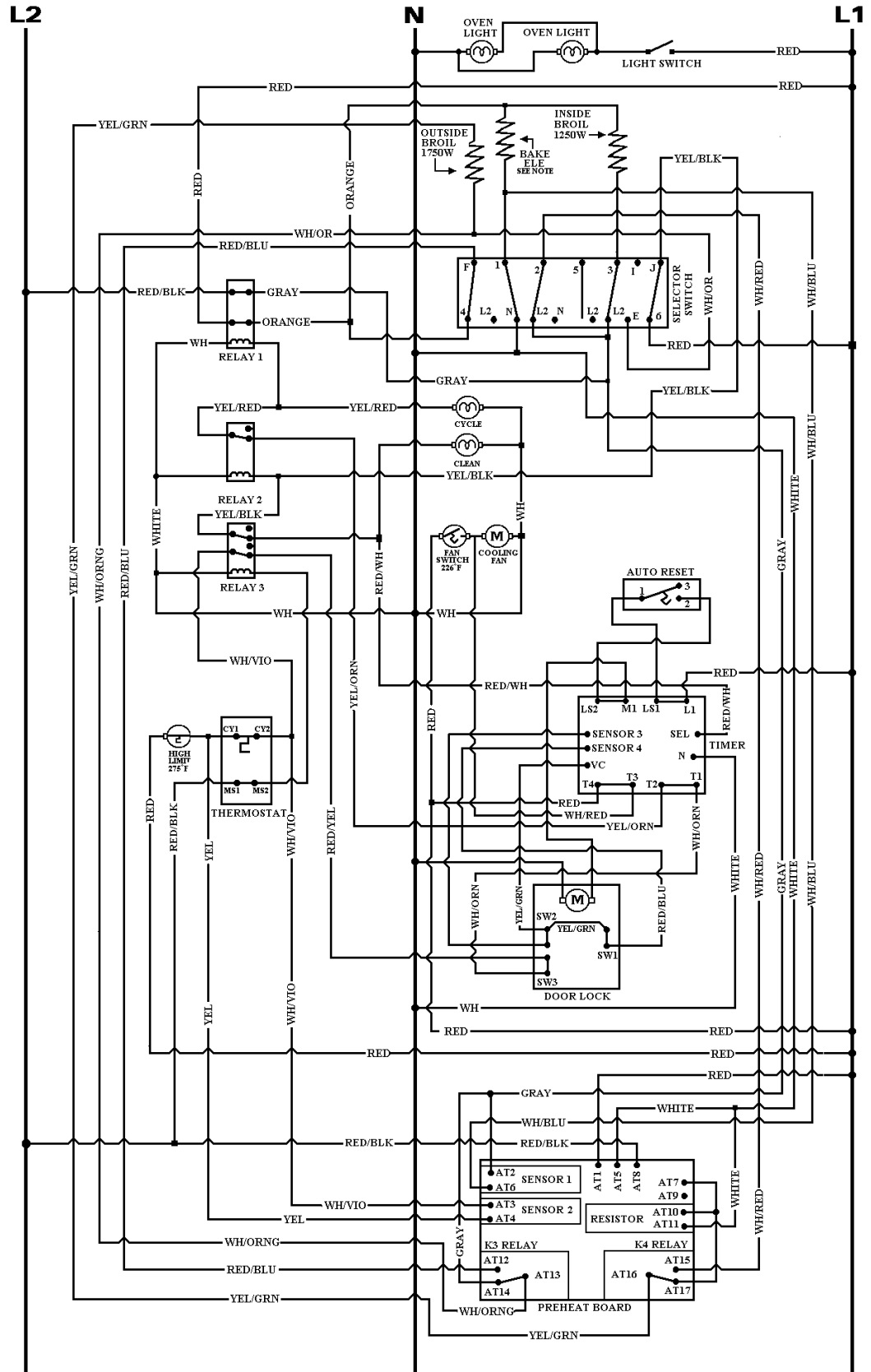

VDSC487 L.H. OVEN SELF-CLEAN

- 10 seconds after the signal to **Sensor #3**, switch LS2-M1 is opened, stopping the door lock motion and switches **T1-T2**, and **T3-T4** which switches **Relay #1**, powering the **Cooling Fan**, which closes **Relay #1** powering the **inside and outside Broil Elements** to 208/240V and the **Bake Element** to 120V.
- **Auto Reset** switches to 1-3 which turns **Door Lock indicator light** on and disables **Door Lock Motor** circuit.
- **Timer** switches **T3-T4**, **T1-T2** open, turning off the **Cooling Fan**, which will then be powered at 120V by the **Fan Limit Switch** when needed, and opening the circuit to **Relay #1** which disables the Heating Elements. **Switch LS2-M1** closes to power the **Door Lock Motor**.
- **Auto Reset** switches 1-2 closed allowing the **Door Lock Motor** to operate and turning the door lock light off. The **Door Lock Motor** operates until 2 seconds after **Sensor 4** is signaled the VC that the **Door Lock SW1** has been closed mechanically by the door lock bolt. The **Door Lock / Timer** switches LS2-M1 and LS1-L1 open and the timer resets.

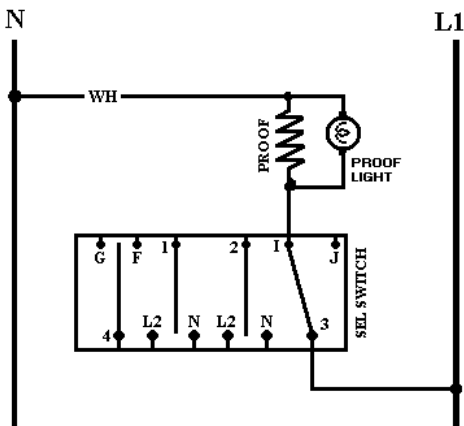
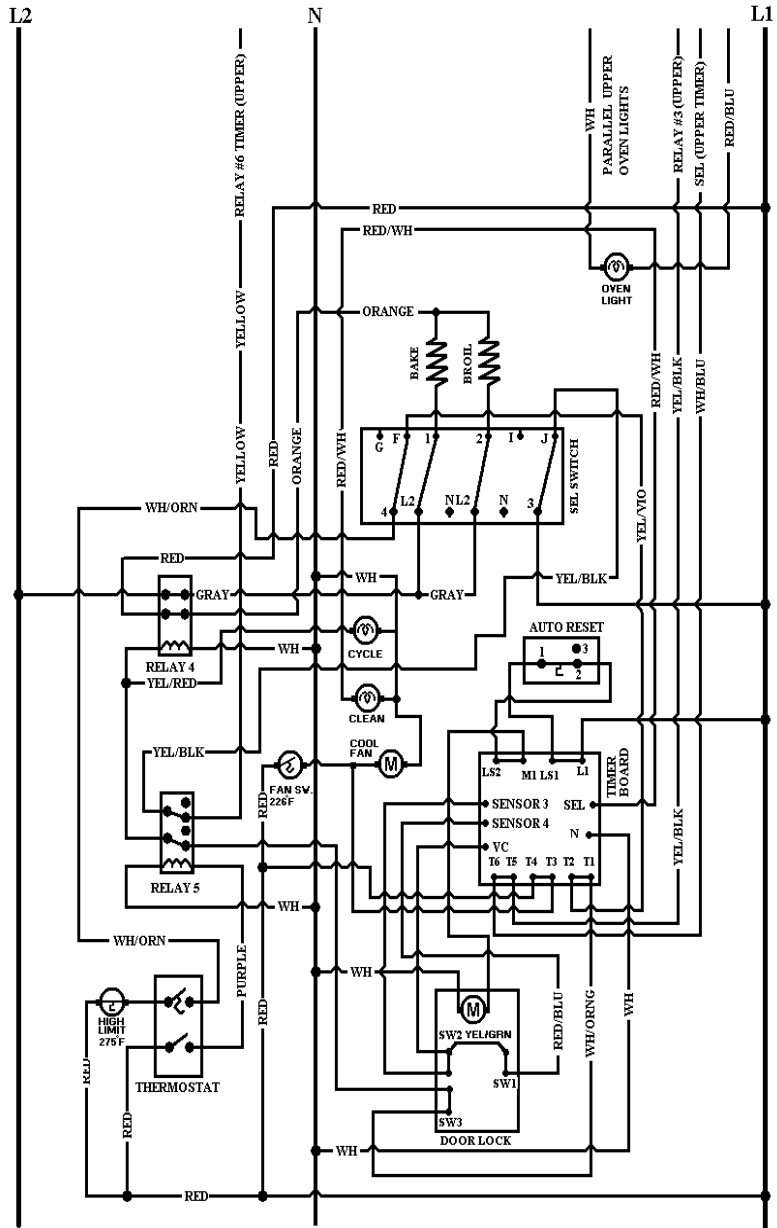

PROOF CIRCUIT FOR THE LEFT HAND OVEN

TROUBLESHOOTING GUIDE ---Dual Fuel / Self-clean / VDSC

PROBLEM	PROBABLE CAUSE	CORRECTION
A. No Bake, No Broil No Cycle Light, No Power to Relay #1.	A-1 House Breaker or fuse open	A-1 Reset Breaker or replace fuse
B. No Bake, No Broil No Cycle Light Power to Relay #1 (Red – Red/Black) terminals #1 & #3) No power to Relay #1 Heater.	B-1 Timed Bake/Broil function switch set to Timed function (wall ovens) B-2 Power Relay #1 Heater circuit open (Power Relay test procedure pg 24) B-3 Open contacts Relay #2 (single / upper oven) (wh/red wire to neutral pins #1 and #7). Open contacts relay #5 (lower oven). (blue wire to neutral pins #1 and #7) B-4 Open contact Relay #3 (single / upper oven) (red/blu contact #3 to wh/vio Contact #9) or open contact Relay #6 (lower oven) (Brown contact #3 to wh/ vio contact #9) B-5 Open Thermostat cycling contacts #1 and # 2 B-6 Open High Limit Switch (contacts normally closed)	B-1 Set Timed Bake/Broil function switch to manual. B-2 Replace Power Relay #1 (Relay #1 Part# PM010026) B-3 Replace Relay #2 (single / upper oven or Relay #5 (lower oven) (Relay #2 & #5 part # PM010029) B-4 Replace Relay #3 (upper oven) or Relay #9 (lower oven) (Relay PN 010029) B-5 Replace Thermostat B-6 Replace High Limit Switch
C. No Bake Functions Broil functions normally and the Cycle Light is on	C-1 Open Bake Element (see pg #21 for C-2 Open selector switch contacts 1 to L2 (See pg # 22 for selector Switch contact checks) C-3 Burned Wiring of Terminal connections	C-1 Replace Bake Element C-2 Replace Selector Switch C-3 Replace or Repair burned wiring and / or Terminals (spade) connections.
D .Poor Baking Results Broil functions Normally, Cycle Light is on.	D-1 Low Voltage Supply (240 VAC required). D-2 Restricted Air Flow through the oven cavity. D-3 No Top Heat from Broil Element. Open Selector Switch contacts 3 to E (see Pg #22 for selector switch checks) D-4 Check Use and Care for suggested Baking tips.)	D-1 Inform Customer of requirements. D-2 Clear restriction from oven vent. D-3 Replace Selector Switch

TROUBLESHOOTING GUIDE ----Dual Fuel / Self-clean / VDSC

PROBLEM	PROBABLE CAUSE	CORRECTION
E. No Convection Bake, Bake and Broil functions normally, Cycle Light is on.	E-1 Open Selector Switch contact 6 to I (see pg #22 for details) E-2 Open Convection Motor winding E-3 Burned wiring or terminal connections	E-1 Replace Selector Switch E-2 Replace Convection Motor E-3 Replace burned wiring or terminal connectors.
F. No Convection Cook function, Bake and Broil functions normally, Cycle :Light is on.	F-1 Open Convection Cook Element. (see pg #22) F-2 Open Selector Switch contacts 5 to L2 (see pg #22)	F-1 Replace Convection Cook Element F-2 Replace Selector Switch
G. Convection Cook Heats, No Air Circulation	G-1 Open winding in Convection Fan motor. G-2 Frozen Motor Shaft G-3 Open Selector Switch contacts I to 6 (see pg #22)	G-1 Replace Fan Motor G-2 Replace Fan Motor G-3 Replace Selector Switch
H. No Mini-Broil function, Bake functions normally, Cycle Light is on	H-1 Open Selector Switch contacts 3 to L2 (see pg #22) H-2 Open Inside Broil Element (see pg #22)	H-1 Replace Selector Switch H-2 Replace Inside Broil Element
I. No Maxi-Broil function, Bake functions normally, Cycle Light is on, Mini-Broil functions normally.	I-1 Open Selector Switch contacts F to 4, 2 to L2 and/or 3 to L2 (see pg #22) I-2 Open Outside Broil Element	I-1 Replace Selector Switch I=2 Replace Outside Broil Element
J. No Maxi-Broil function, No Top Heat in Bake function, Cycle Light is on.	J-1 Open Selector Switch contacts F to 4, 2 to L2 and / or 3 to L2 (see pg #22) J-2 Open Inside and Outside Broil Elements. (See pg #21) J-3 Burned wiring or terminal connections	J-1 Replace Selector Switch J-2 Replace open Broil Elements J-3 Replace Burned wiring and/or terminal (spade) connectors.
K. No convection Broil, Bake is normal, Broil is normal, Cycle Light is on. No Mini-Broil.	K-1 Open Convection Motor winding. K-2 Open Selector Switch, contacts 3 to L2 K-3 Open Inside Broil Element (see pg #21)	K-1 Replace Convection Motor. K-2 Replace Selector Switch. K-3 Replace Inside Broil Element

TROUBLESHOOTING GUIDE ---Dual Fuel / Self-clean / VDSC

PROBLEM	PROBABLE CAUSE	CORRECTION
<p>L. No Self-clean, Bake and Broil functions normally</p> <p>Door won't lock. No Clean Light. No 120 VAC supply to Door Lock module / timer (PC board) pg #20, item 1 Sel.</p>	<p>L-1 Open Selector Switch contacts J to 6</p> <p>L-2 Open contact Relay #2 (single / upper oven) or Relay #5 (lower oven).</p> <p>L-3 Open contacts Relay #3 (single / upper oven) or Relay #6 (lower oven).</p>	<p>L-1 Replace Selector Switch</p> <p>L-2 Replace Relay #2 (single / upper oven) or #5 (lower oven).</p> <p>L-3 Replace Relay #3 (single / upper oven) or Relay #6 (lower oven). (120VAC current path from Sel on PC Board to Normally closed contacts on Relay #2 to Selector Switch contacts J to 6 to Line L1).</p>
<p>M. No Self-clean Bake and Broil functions normally</p> <p>Door won't lock- 120 VAC to Door Lock Module / Timer (PC Board) is present-No Motor Movement-Clean Light is on.</p>	<p>M-1 Open Relay contacts LS1 - 1 and / or LS2 - M1 on Door Lock Module/Timer (PC Board)</p> <p>M-2 Open contacts 1 to 2 on Auto Reset Thermostat.</p> <p>M-3 Open Windings in Lock Motor</p>	<p>M-1 Replace Door Lock Module / Timer (PC Board)</p> <p>M-2 Replace Auto Reset Thermostat.</p> <p>M-3 Replace Lock Motor assembly.</p>
<p>N. Door Lock Motor continues to run. No signal to sensor (see pg #19) #3 on PC Board that closes T1-T2 and T3-T4. Clean Light on.</p>	<p>N-1NO SW2 Switch (closed by motor movement) on Door Lock Mechanism not closing.</p>	<p>N-1 Adjust SW2 Switch position or Replace faulty Switch.</p>
<p>O. Door Lock Motor engaged. Signal To Sensor #3 (see pg #19). No Heat Clean Light On.</p>	<p>O-1 Door Lock Module / Timer Relay T1-T2 and T3-T4 not closing.</p>	<p>O-1 Replace PC Board</p>
<p>P. Door Lock Motor engaged. Cooling Fan Motor runs (PC Board T3-T4 closing) No Heat.</p>	<p>P-1 Door Lock Module / Timer (PC Board) Relay T1-T2 Not closing.</p> <p>P-2 Door Lock Module / Timer (PC Board) Relay T1-T2 closing. Check SW3 on Door Lock Assembly.</p>	<p>P-1 Replace PC Board</p> <p>P-2 Replace SW3</p>

VDSC "LOCKED" DOOR

In the unlikely event the door lock motor should fail in the "locked" position you will need:

1. To fashion a hook on the end of a 12" long stiff wire.
2. Insert the hook between the door and the front frame assembly at the top, see "A" illustration at the right. The hook on the wire should be to the right of the latch hook.
3. Engage the door latch hook with the wire hook and pull the latch hook to the left until the door is released, see illustration below.

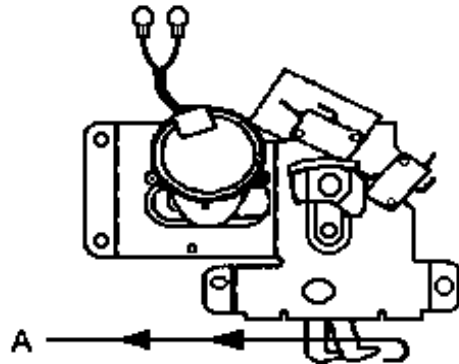
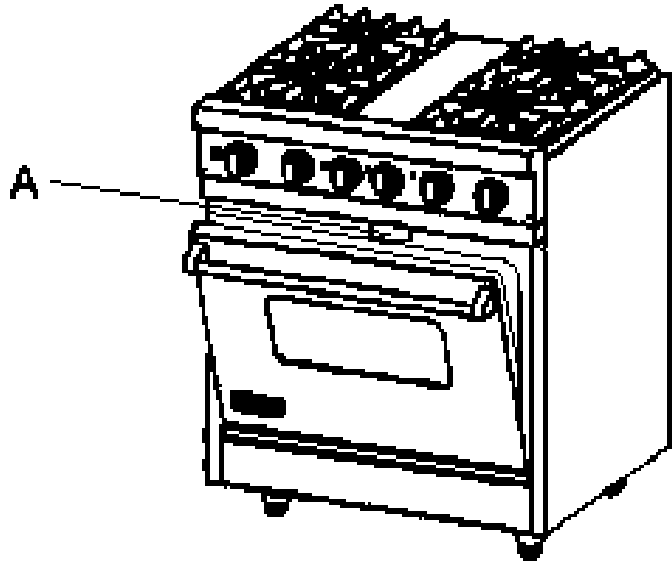

VDSC367 GRIDDLE ASSEMBLY

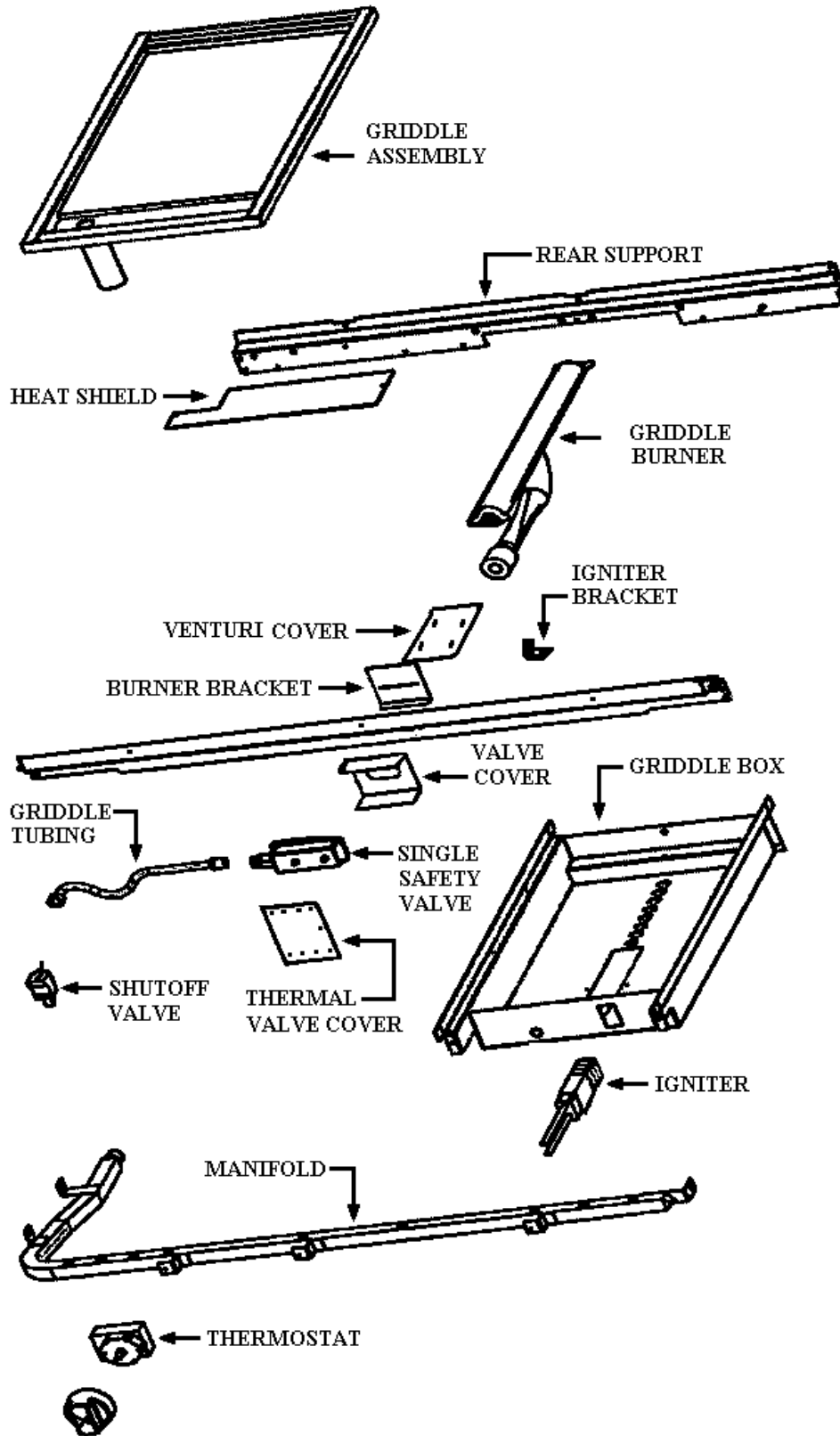

VDSC367 GRILL ASSEMBLY

