

SERVICE NOTE BOOK

**VDSC (DUAL FUEL) SELF-CLEAN RANGE / VESC (ELECTRIC)
SELF-CLEAN RANGE / VERT (ELECTRIC) RANGE-TOP**



VIKING RANGE CORPORATION

TABLE OF CONTENTS

VDSC (Dual fuel) / VESC (Electric) RANGES / VERT (Rangetop)

COMPONENTS AND FUNCTIONAL PARTS:

Control / Timer -----	3
Auto Reset Switch (thermostat) -----	3
High Limit Switch-----	4
Cooling Fan Limit Switch -----	4
Selector Switch -----	4
Oven Thermostat -----	4
Door Lock Assembly -----	5
Relay #1 -----	5
Relay #2 and #3 -----	5
Convection Fan -----	6
Cooling Fan -----	6
Oven Light Assembly -----	6
Voltage and Resistance checks -----	7 - 8
Selector Switch Contacts -----	9

WIRING DIAGRAMS

Bake -----	10
Convection Bake -----	11
Convection Cook -----	12
Mini Broil -----	13
Maxi Broil -----	14
Convection Broil -----	15
Self Clean (initiate door lock) -----	16
Clean (door lock below 575*) -----	17
Clean (door lock above 575*) -----	18
Clean Finished (door lock above 575*) -----	19
Clean Finished (door lock below 575*) -----	20

ELECTRICAL CONNECTIONS

Without Conduit -----	21
With Conduit -----	22

DISASSEMBLY -----	23 - 25
-------------------	---------

SERVICE

Locked door -----	26
-------------------	----

VESC / VERT Top removal -----	27
-------------------------------	----

VESC / VERT Voltage / Resistance / Current checks -----	28
---	----

VDSC COMPONENTS (WITH COLOR CODED WIRES)

DOOR LOCK CONTROL / TIMER

Function: The Door Lock Control / Timer is activated by the line voltage at the "SEL" (1) contact. Relay "RL1" (2) and "RL2" (3) close providing voltage to the Door Lock Motor. The Relays stay closed until 10 seconds after sensor #3 (4) receives a signal that the Door Lock is fully closed. Once this happens Relay "RL2" (3) opens to stop the Door Lock Motor. Relay "RL1" (1) stays closed providing voltage to the Auto Reset thermostat. Relays "RL3" and "RL4" close powering the Cooling Fan Motor and Cycle Relay. "RL3" and "RL4" will stay closed for 3 ½ hours unless power is interrupted to sensor #3 (4) or SEL (1). In which case "RL3" and "RL4" will open, interrupting the clean cycle and Cooling Fan, and "RL2" (3) will close, opening the Door Lock. "RL2" (3) will stay closed until 2 seconds after sensor # 4 (5) is powered.

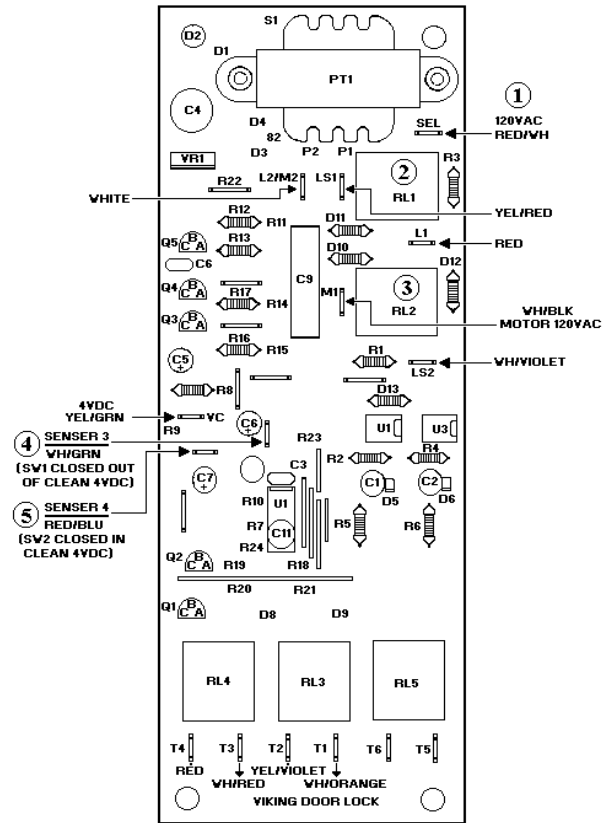

CONTROL CIRCUIT BOARD

AUTO RESET SWITCH

Function: The Auto Reset Switch is a single pole / double throw switch (thermostat) which is activated by a thermobulb and lever which is calibrated to 575* F plus / minus 25* F. **Clean door lock below 575* F.** The Door Lock Motor is energized through the Auto Reset Switch (thermostat) contacts 2 - 1. **Clean door lock above 575* F.** Auto Reset Switch (thermostat) switches to contacts 1 -3 turning on the Door Lock indicator Light and disables the Door Lock Motor circuit. **Final below 575* F.** Auto Reset Switch (thermostat) switches to contacts 1 -2, turning off the Door Lock Motor circuit through door Lock Motor / Timer Relay LS2 - M1. Door Lock Motor operates until 2 seconds after sensor 4 is signaled by VC that the Door Lock switch SW1 has been closed mechanically by the door lock bolt. The Door Lock / Timer switches LS2 - M1 and LS1-L1

open and the timer resets.

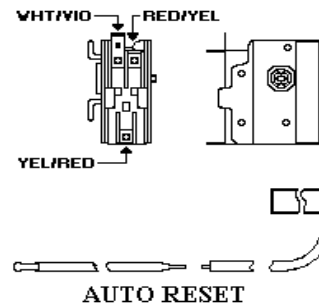

VDSC COMPONENTS (Con't)

HIGH LIMIT SWITCH

Function: The Switch has a ½ “ bi-metal disc. The two metals have different thermal coefficients of expansion which cause the disc to bow as it heats up. When it reaches the calibration temperature the disc snaps open, which opens the electrical contacts. The Switch opens when temperature reaches 275* F plus or minus 9*F and will close when temperatures are 248* F plus or minus 9*F.

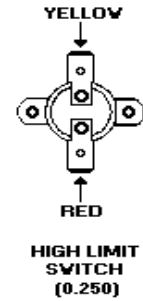

COOLING FAN LIMIT SWITCH

Function: The Switch has a ½ “ bi-metal disc. The two metals have different thermal coefficients of expansion which cause the disc to bow as it heats up. When it reaches the calibration temperature the disc snaps closed, which closes the electrical contacts. The Switch closes when temperatures reach 230* F plus or minus 9* F and will open when temperatures are below 203* F plus or minus 9*F.

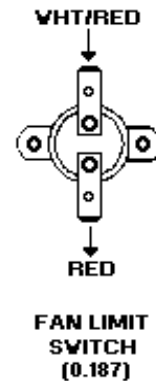

SELECTOR SWITCH

Function: Rotating the shaft twists a cam which moves one or more spring loaded levers, which make contact with a terminal closing the circuit.

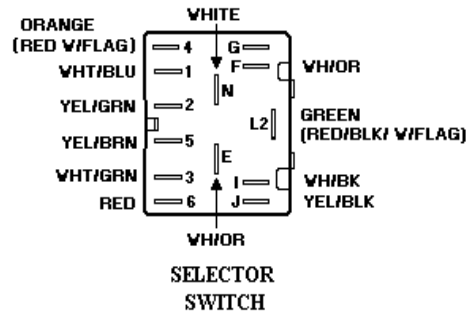

OVEN THERMOSTAT

Function: As the shaft is rotated from the OFF position clockwise, an internal cam pushes a lever, which increases the temperature at which the thermostat cycles. Rotating the shaft 212* (angle *) switches an external (clean) Micro Switch to the closed position.

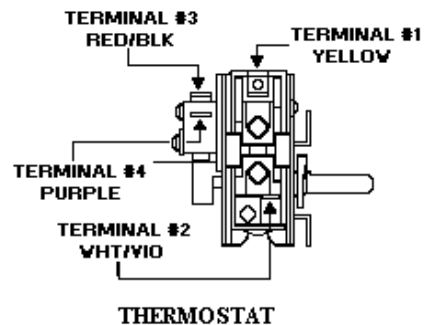

VDSC COMPONENTS (Con't)

DOOR LOCK

Function: When the Door Lock Motor is powered it turned a cam which pulls back a lever. As the lever moves back it allows a micro switch (SW1) to open. When the lever reaches the fully closed position it closes a double stacked micro switch (SW2 & SW3). **Door lock switch SW2** completes the circuit to sensor #3 on the Door Lock Control/timer board. After 10 seconds LS1-M1 opens, stopping the Door Lock motion. **Door Lock Switch #3** closes T1-T2 and T3-T4 energizing Power Relay #1 and the Cooling Fan. Closing Power Relay contacts supplies 240 VAC to both Broil Elements and 120 VAC to the Bake Element.

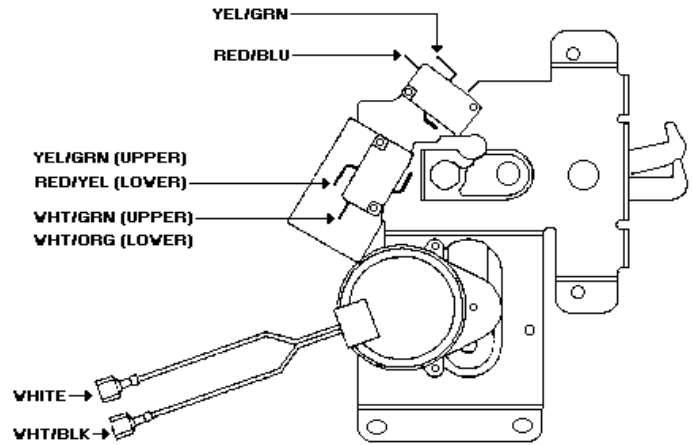

DOOR LOCK MOTOR

SW3) by the Door Lock Bolt.

POWER RELAY #1

Function: Relay #1 (power) supplies power to the Bake and Broil Elements.

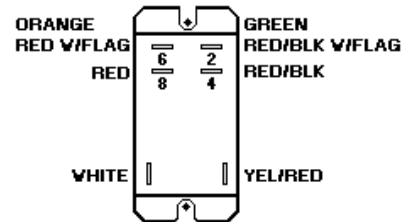

RELAY #1

RELAY #2 and RELAY #3

Function: Setting the selector switch to clean closes the Heating Element circuits 4-F, 1-N, 2-L2, 3-L2 and Door Lock Module / Timer circuit J-6, energizing Relay #2. The thermostat cycling contacts 1 to 2 and the clean switch contacts 3 to 4 close energizing Relay #3. Relay #3 allows circuit J-6 to turn on the Clean Indicator Light and enable the Door Lock Module / Timer to close Relays LS1-L1 and LS2 - M1. This powers the Door Lock Motor until 10 seconds after Sensor 3 is signaled by VC that Door Lock Switch SW2 has been closed mechanically (along with

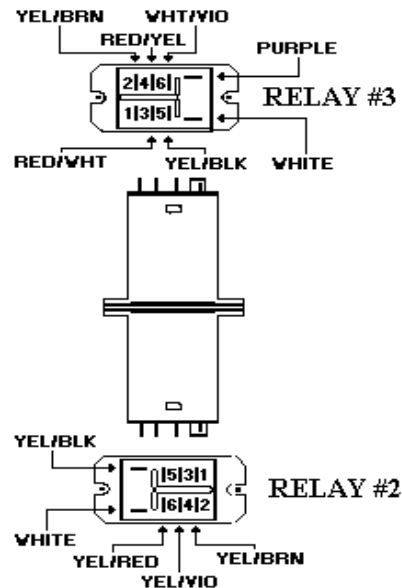

VDSC COMPONENTS (Con't)

CONVECTION FAN MOTOR

Function: Provides an even flow of air in the oven cavity for more even baking.

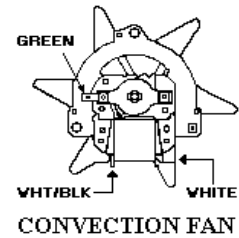

COOLING FAN MOTOR

Function: Provides a continuous supply of cool air during self clean cycles to keep the Door Lock Motor and associated circuits cool.

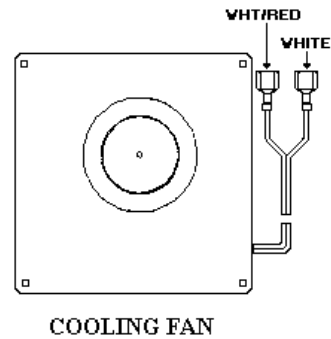

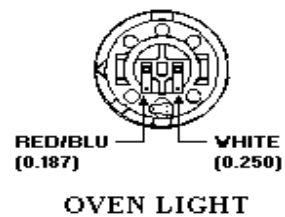

OVEN LIGHT

Function: Provides interior oven light for viewing baking products.



VOLTAGE READINGS

MEASURED WITH DOOR OPEN

		
T4	107VAC	70VAC
T3	4VAC	16VAC
T2	4VAC	16VAC
T1	5VAC	1VAC

MEASURED WITH DOOR LOCKED

T4	80VAC	56VAC
T3	85VAC	56VAC
T2		90VAC 56VAC
T1	93VAC	56VAC

VC--4VDC

SENSOR 3--3VDC SW2 closed in self clean (Locked). 

SENSOR 4--4VDC SW1 closed with clean lock open. 

M1--120VAC lock motor supply voltage. (31VAC in locked position)

LS2--70VAC (unlocked)--**55VAC** (locked)

L1-- 70VAC (unlocked)--**56VAC** (locked) 

L2/M2--16VAC (unlocked)--**32VAC** (locked)

LS1--107VAC (locked or unlocked)

SEL--120VAC SUPPLY

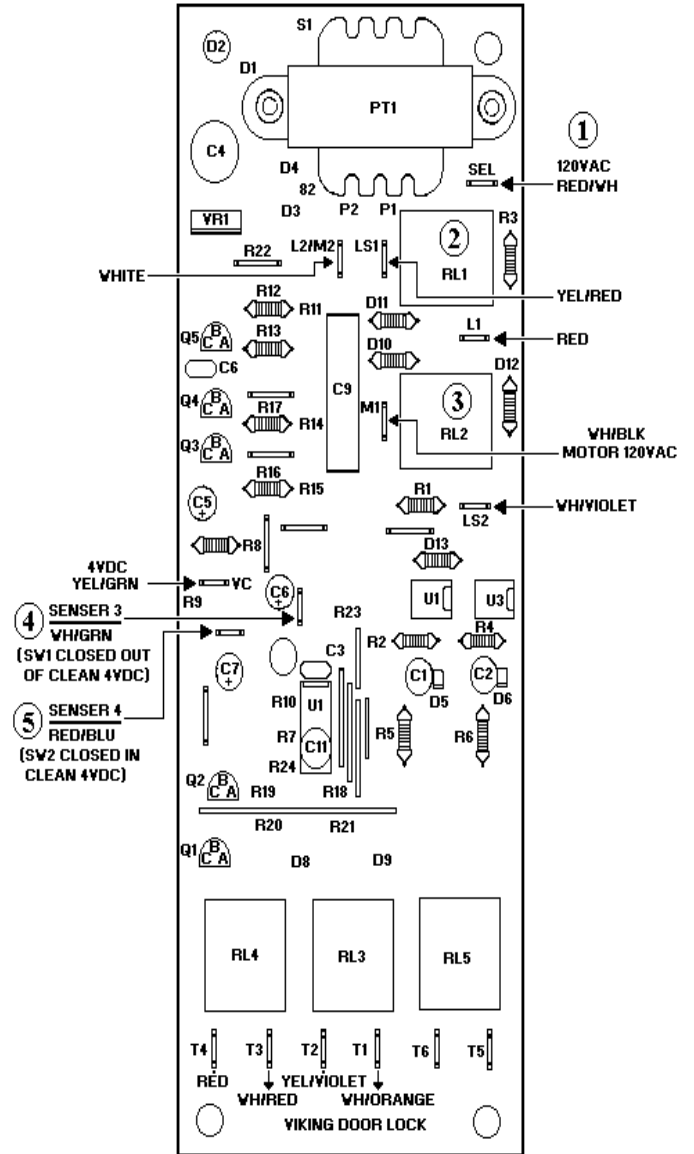
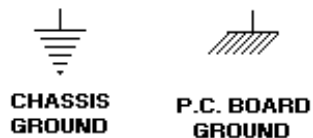

CONTROL CIRCUIT BOARD

VOLTAGE and RESISTANCE READINGS

BAKE ELEMENT:

“A” to “B” 21.1 Ohms

“A” to “B” 240VAC during Bake and Convection Bake.

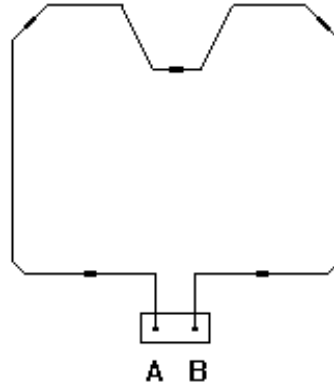

BROIL ELEMENT:

“A” to “D” (outside element) 32.6 Ohms

“A” to “D” 50VAC during Bake and Convection Bake.
240VAC during Maxi Broil.
240VAC during Convection Broil
240VAC during Self-clean

“B” to “C” (inside element) 45.2 Ohms

“B” to “C” 70VAC during Bake and Convection Bake.
240VAC during Mini Broil
240VAC during Maxi Broil
240VAC during Convection Broil
240VAC during Self-clean

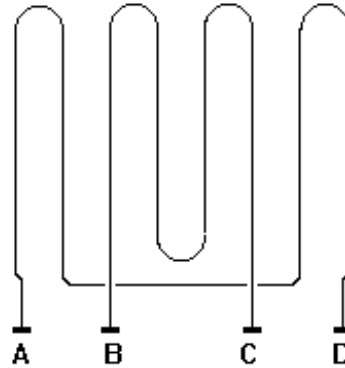

CONVECTION ELEMENT:

“A” to “B” 26 Ohms

“A” to “B” 240VAC during Convection Cook

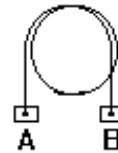

8 POSITION SELECTOR SWITCH
(With shaft position and internal connections)

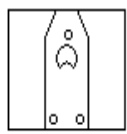
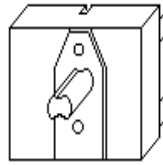
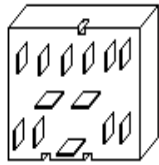

OFF

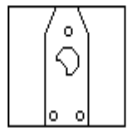
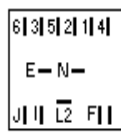

BAKE

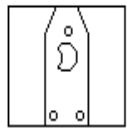
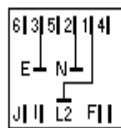

CONVECTION
BAKE

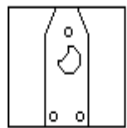
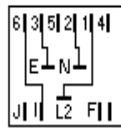

CONVECTION
COOK

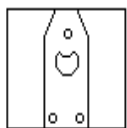

BROIL

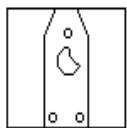
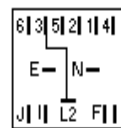

MAXI
BROIL

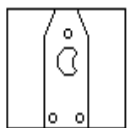
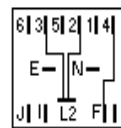

CONVECTION
BROIL

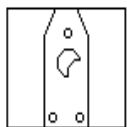
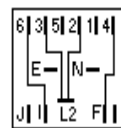

SELF
CLEAN

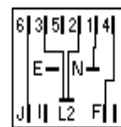

SELF CLEAN

Selector Switch closes Heating Element contacts 4-F, 1-N, 2-L2, 3-L2, and Door Lock Module /Timer contacts J-6 energizing Relay #1.

Thermostat Clean Position closes Thermostat cycling contacts 1-2 and normally open (N) - common (C) energizing Relay #3.

Relay # 3 turns on the Clean indicator Light and energizes Door Lock Module / Timer (PC Board) relays LS1-L1 and LS2-M1, also supplying 120VAC to SEL on the PC board

Relays LS1 and LS2 turns the Door Lock Motor on through the Auto Reset Thermostat contacts 2-1.

Door Lock Motor rotates opening SW1 and closing SW2 and SW3.

Door Lock Switch #2 completes the circuit to sensor #3 on the PC board. After 10 seconds LS1-M1 opens, stopping the Door Lock motion.

Door Lock Switch #3 closes T1-T2 and T3-T4 energizing Power Relay #1 and the Cooling Fan. Closing Power Relay #1's contacts supplies 240VAC to both Broil Elements and 120VAC to the Bake Element.

CLEAN DOOR LOCK ABOVE 575°F
+/-25°F

Auto Reset Thermostat switches to contacts 1-3 turning on the Door Lock indicator Light and disables the Door Lock Motor circuit.

CLEAN TEMPERATURE (875°F)
REACHED.

Door Lock Module / Timer opens T3 -T-4 and T1-T2 turning off the Cooling Fan, now powered by the Fan Limit Switch when needed, and opens the circuit to the Power Relay #1 disabling the Heating Elements.

FINAL BELOW 575°F +/-25°F

Auto Reset Thermostat switches to contacts 1-2, turning off the Door Lock Motor circuit through Door Lock Motor / Timer Relay LS2-M-1. Door Lock Motor operates until 2 seconds

BAKE

L2 (BLK)

N (WH)

L1 (RED)

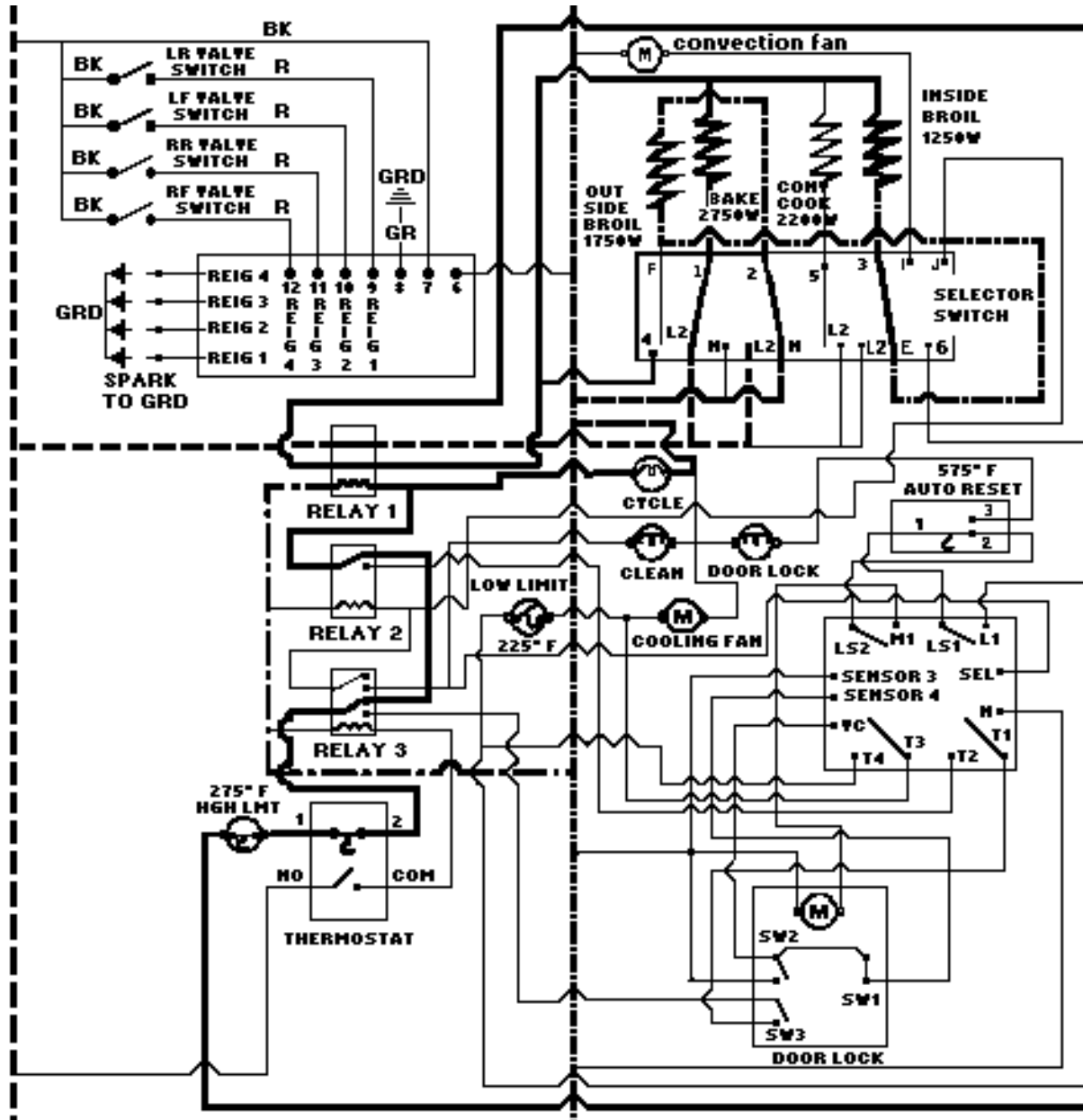

Selector Bake position closes Switches 1-L2, 2-N, and 3-E. The Thermostat closes Switches Cy1-Cy2, which cycles with the oven temperature powering Relay 1 and the Oven cycle light. When Relay 1 closes, it powers the Bake Element at 208v/240v, and with the Broil Element in series across a 120v circuit, it powers the inside Broil Element at 70v and the outside Broil Element at 50v.

Legend

- L1 (Red)
- L2 (Black)
- Neutral
- Sensors

CONVECTION BAKE

L2 (BLK)

N (WH)

L1 (RED)

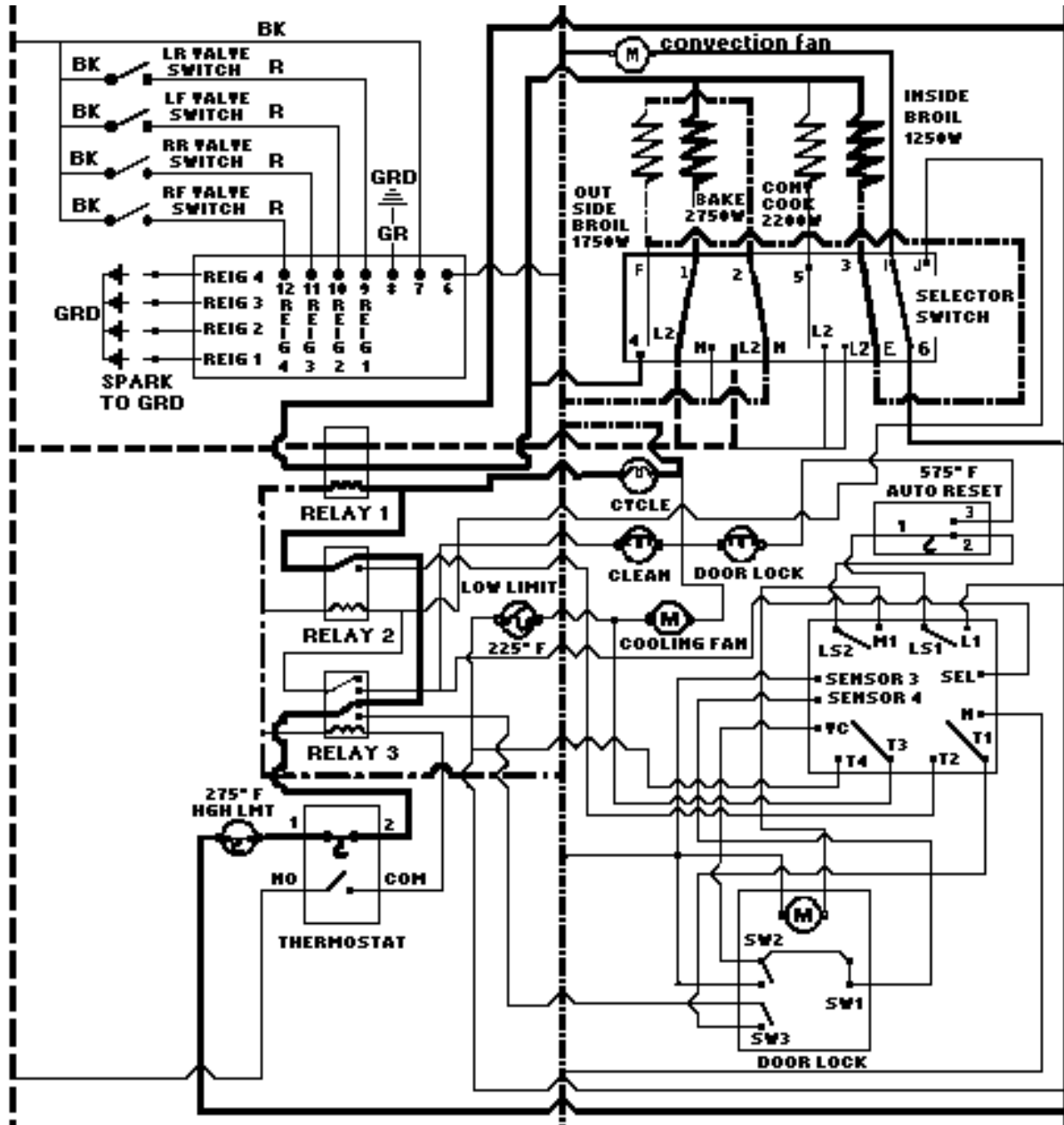

Selector Convection Bake position closes Switches 1-L2, 2-N, 3-E, and 6-1. 6-1 powers the Convection Fan through L-1 at 120v. The Thermostat closes Switches Cy1-Cy2, which cycles with the oven temperature powering Relay 1 and the Oven Cycle Light. When Relay 1 closes, it powers the Bake Element at 208v/240v, and with the Broil Element in series across a 120v circuit, it powers the inside Broil Element at 70v and the outside Broil Element at 50v.

Legend

- L1 (Red)
- L2 (Black)
- Neutral
- Sensors

CONVECTION COOK

L2 (BLK)

N (WH)

L1 (RED)

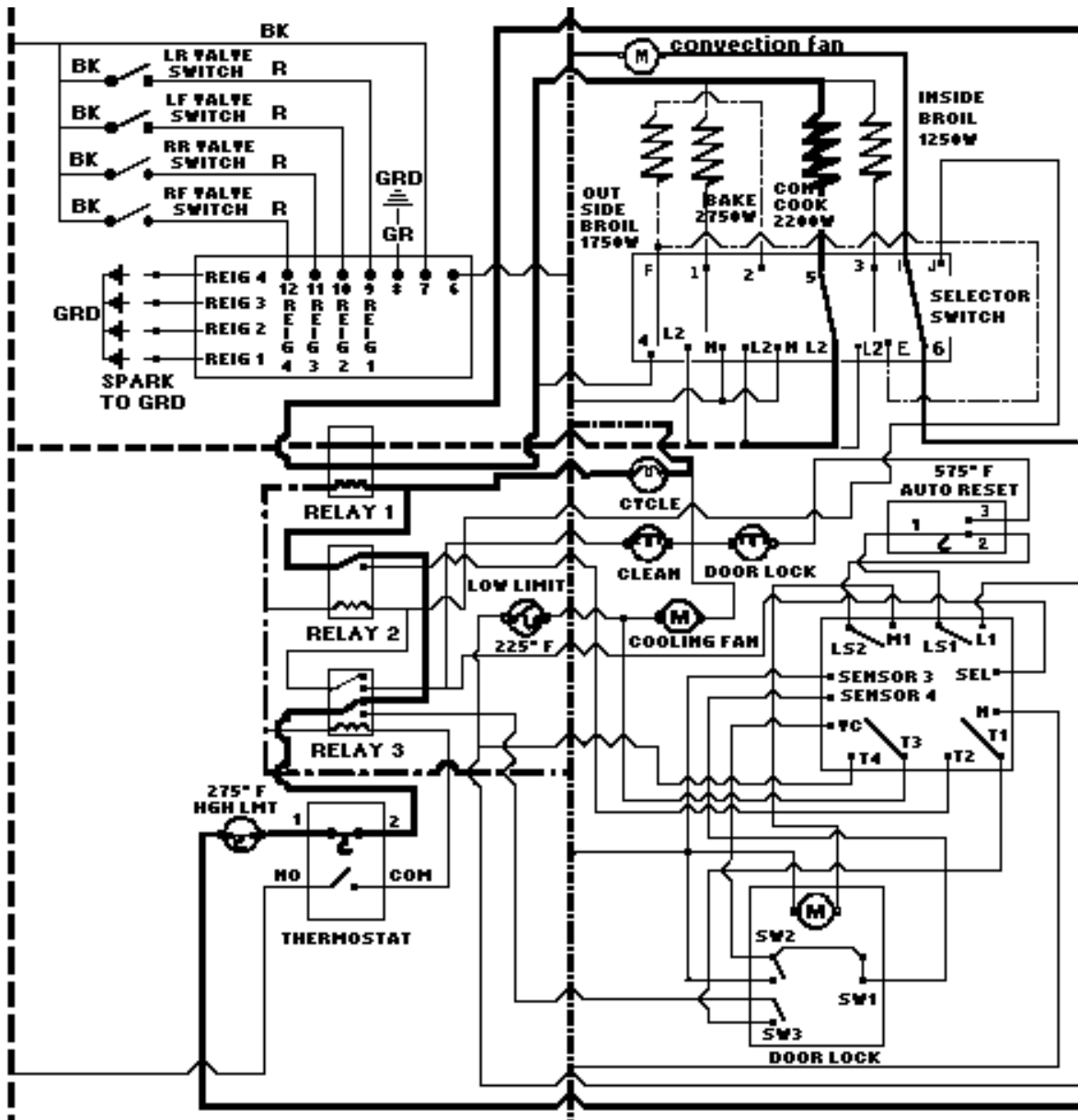

Selector Convection Cook position closes Switches 5-L2 and 6-1. 6-1 powers the Convection Fan through L1- at 120v. The Thermostat closes Switch Cy1-Cy2, which cycles with the Oven temperature, powering Relay #1 and the Oven Cycle Light. When Relay #1 closes, it powers the Convection Element at 208v/240v.

Legend

- L1 (Red)
- L2 (Black)
- Neutral
- Sensors

MINI BROIL

L2 (BLK)

N (WH)

L1 (RED)

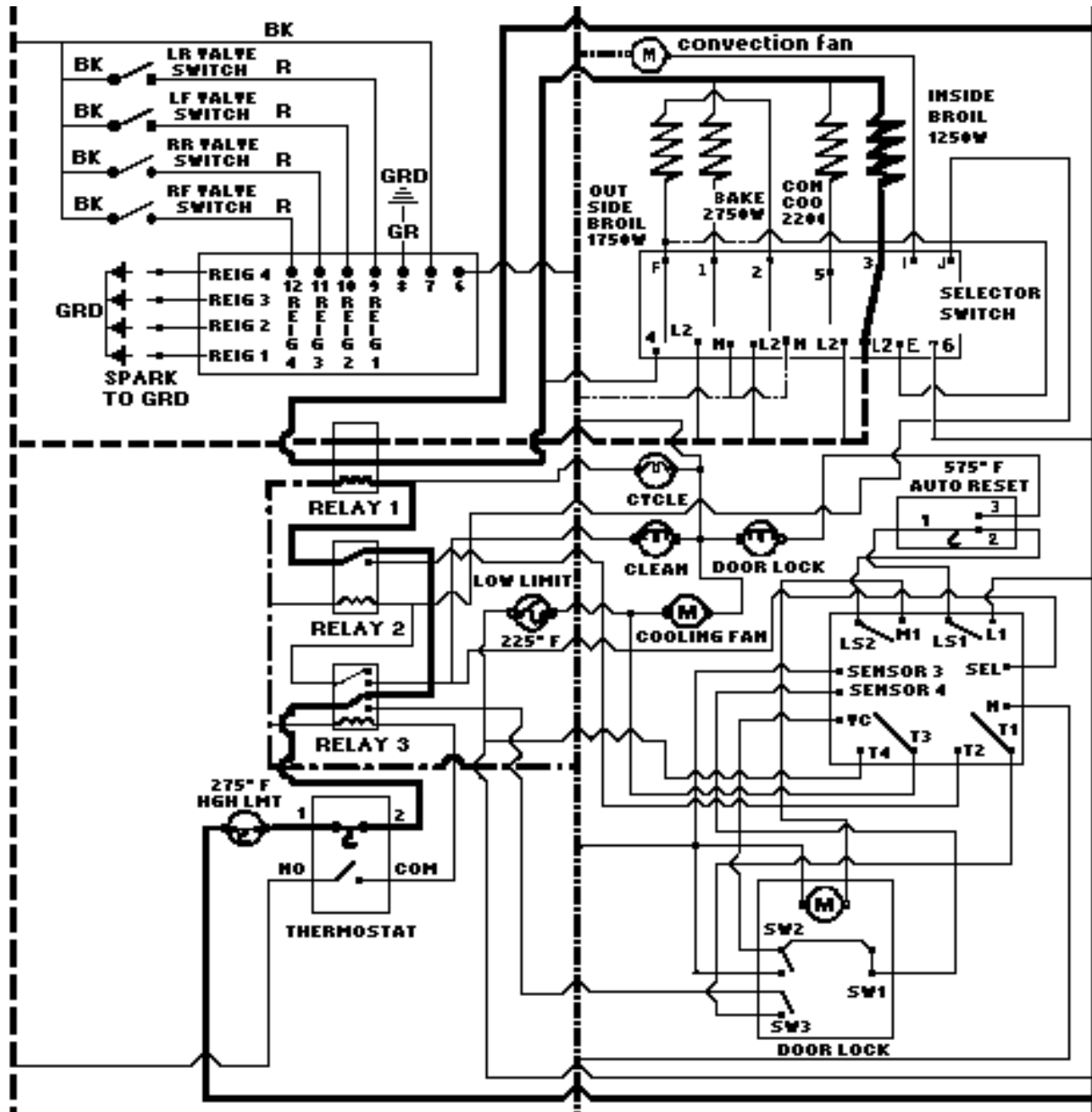

Selector Mini Broil position closes Switches 3-L2. The Thermostat closes Switch Cy1-Cy2, powering Relay #1 and the Oven Cycle Light. When Relay #1 closes, it powers the inside Broil Element at 208v/240v.

- Legend**
- L1 (Red)
 - L2 (Black)
 - Neutral
 - Sensors

MAXI BROIL

L2 (BLK)

N (WH)

L1 (RED)

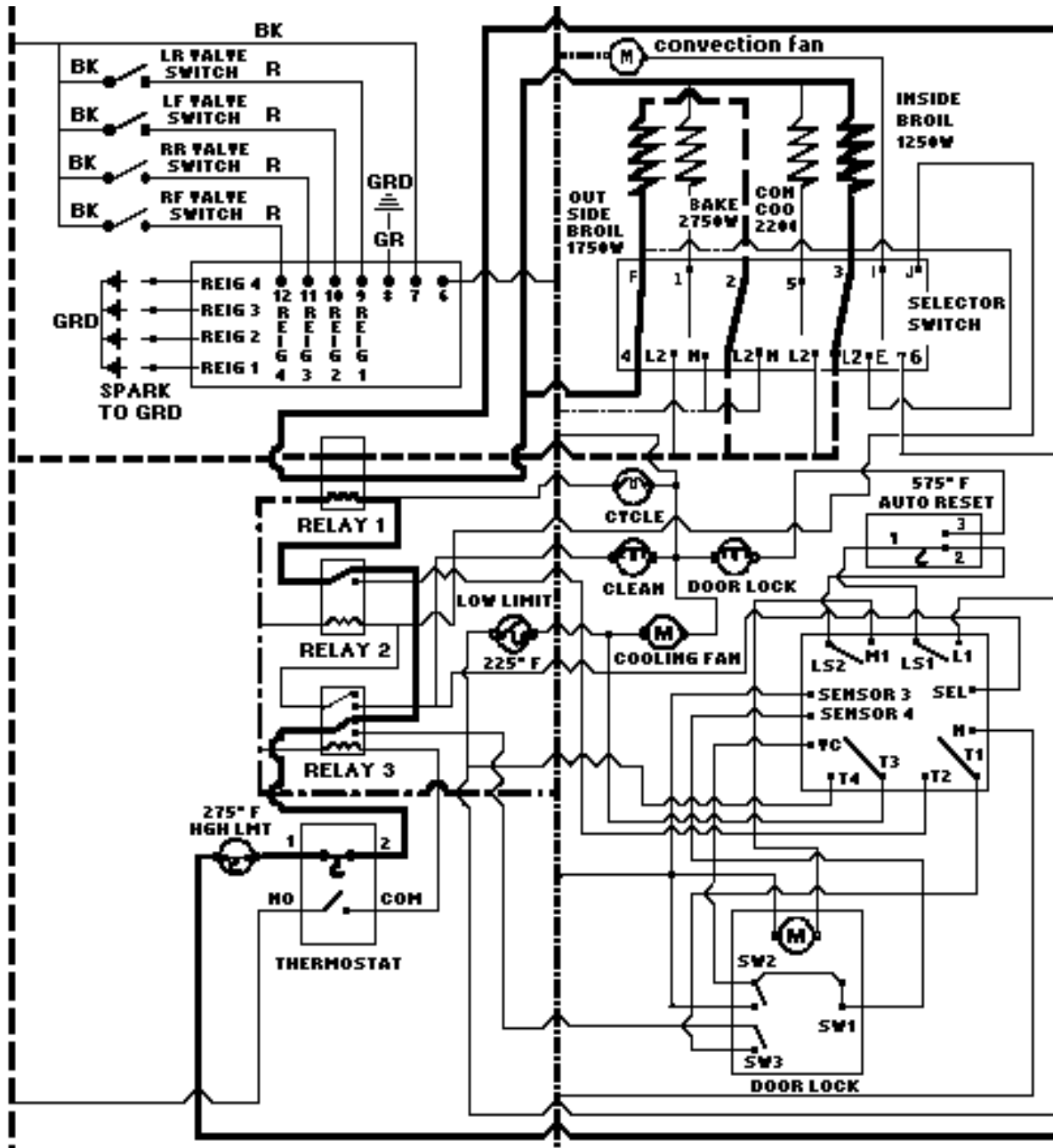

Selector Maxi Broil position closes Switches 4-F, 2-L2, and 3-L2. The Thermostat closes Switch Cy1-Cy2, which cycles with the oven temperature, powering Relay #1 and the Oven Cycle Light. When Relay #1 closes, it powers the inside Broil Element at 208v / 240v and the Outside Broil Element at 208v / 240v.

- Legend**
- L1 (Red)
 - L2 (Black)
 - Neutral
 - Sensors

CONVECTION BROIL

L2 (BLK)

N (WH)

L1(RED)

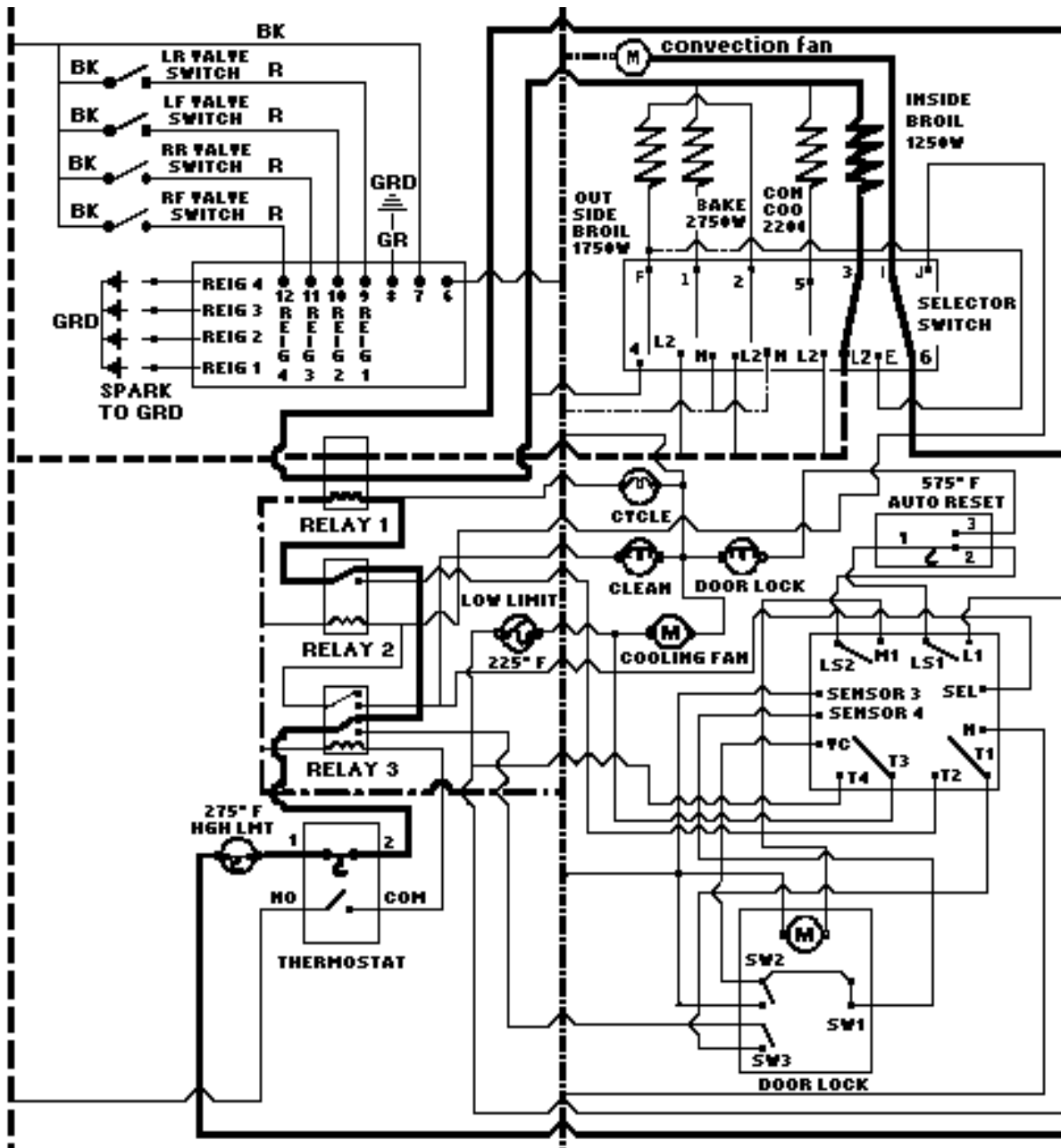

Selector Convection Broil position closes Switches 4-F, 2-L2, 3-L2, and 6-1. 6-1 powers the Convection Fan through L1 at 120v. The Thermostat closes Switch Cy1-Cy2, which cycles the Oven temperature, powering Relay #1 and the Oven Cycle Light. When Relay # 2 closes it powers the inside Broil Element at 208v / 240v and the outside Broil Element at 208v / 240v.

Legend

- L1 (Red)
- L2 (Black)
- Neutral
- Sensors

CLEAN INITIATE UNTIL DOOR LOCK

L2 (BLK)

N (WH)

L1 (RED)

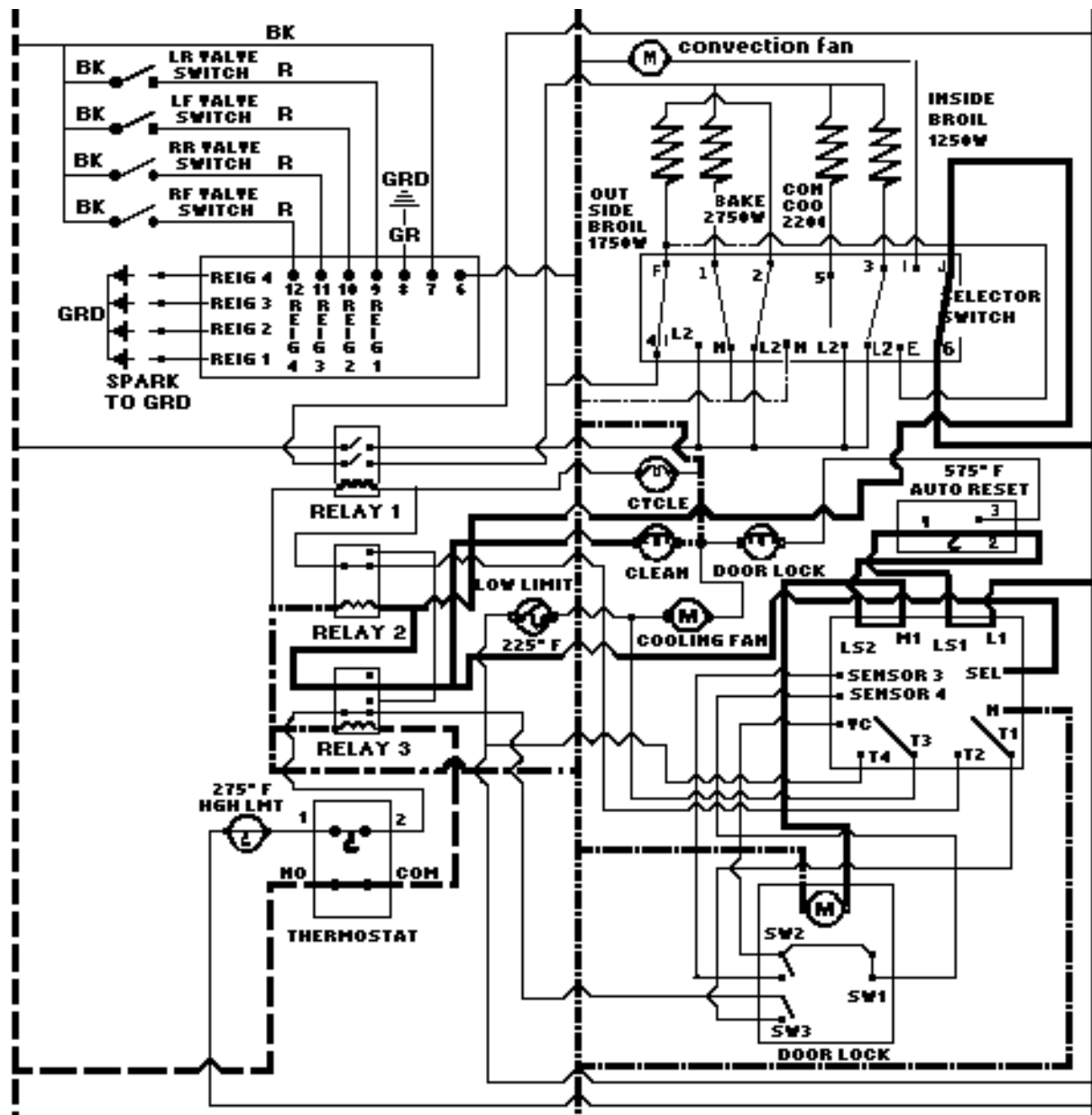

Selector Clean position closes Heating Element circuits 4-F, 1-N, 2-L2, 3-L2 and Door Lock Module / Timer circuit J-6 switches Relay #2. Thermostat clean position closes the Cycle Switch and Thermostat Clean Switch, which switches Relay#3. Switching Relay #3 allows circuit J-6 to turn on the Clean Indicator Light and enable the Door Lock Module / Timer which closes Relays LS1-L1 and LS2-M1. This powers the Door Lock Motor until 10 seconds after Sensor #3 is signaled by VC that the Door Lock Switch SW2 has been closed mechanically (along with SW3) by the Door Lock Bolt.

Legend

- L1 (Red)
- — L2 (Black)
- Neutral
- Sensors

CLEAN DOOR LOCK BELOW 575° ± 25°

L2 (BLK)

N (WH)

L1 (RED)

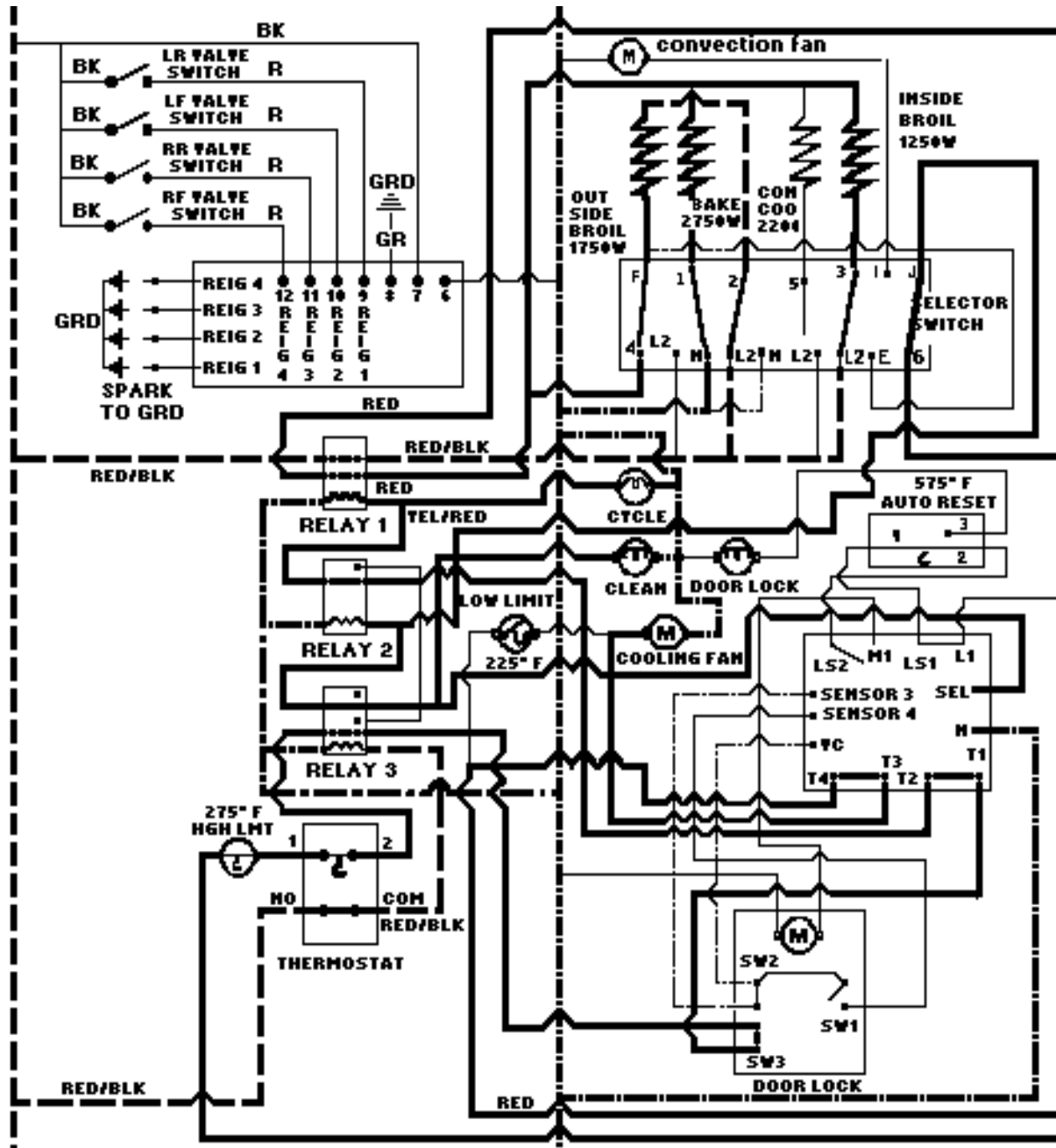

10 seconds after the signal to Sensor #3, Switch LS2-M1 is opened, stopping the door lock motion and Switches T1- T2, and T3-T4 which switches Relay #1, powering the Cooling Fan, which closes Relay #1 powering the inside and outside Broil Elements to 208v /240v and the Bake Element to 120v.

Legend

- L1 (Red)
- L2 (Black)
- - - - - Neutral
- · · · · Sensors

CLEAN DOOR LOCK ABOVE 575° ± 25°

L2 (BLK)

N (WH)

L1 (RED)

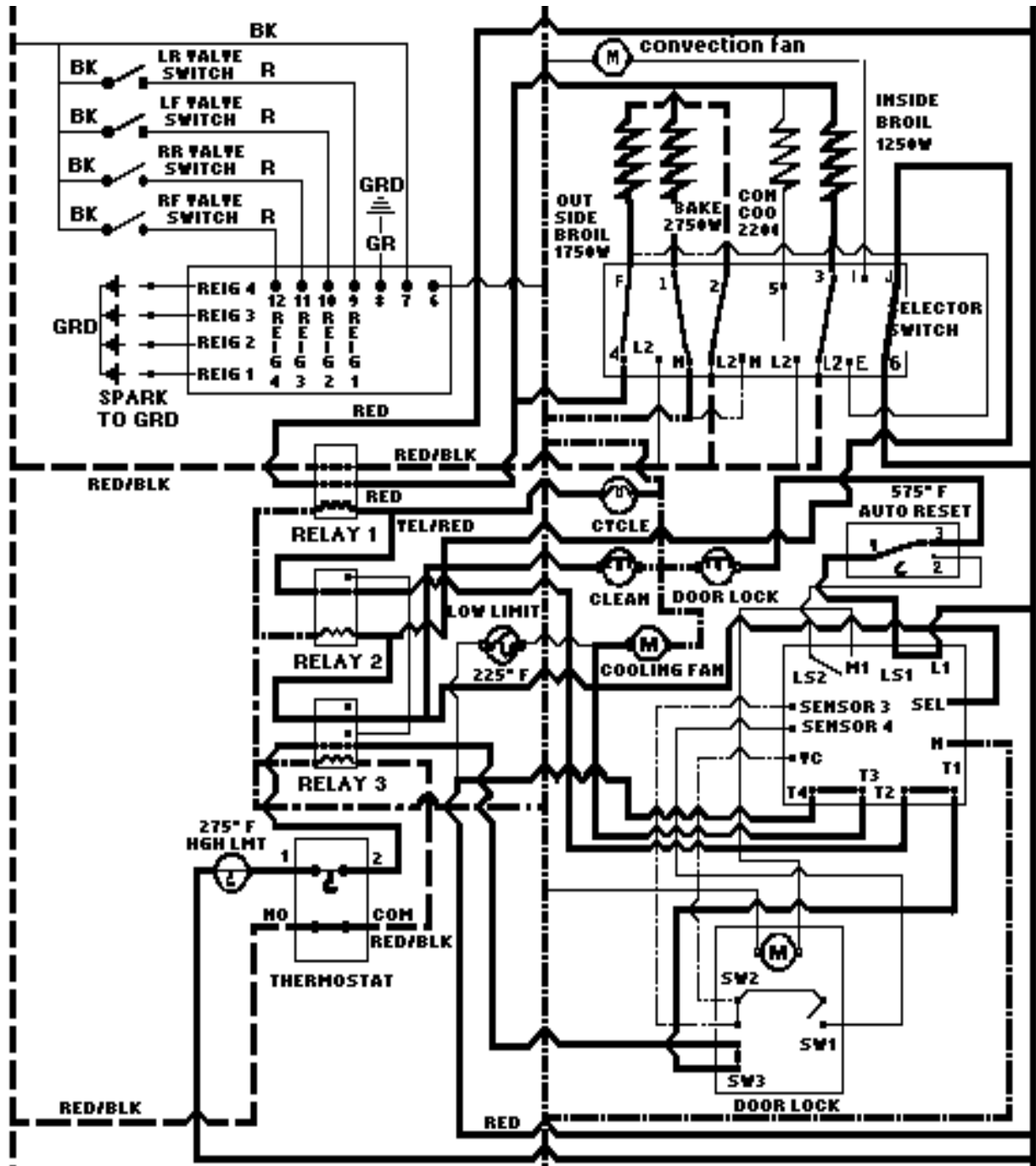

Auto Reset switches to 1-3 which turns Door Lock Indicator Light on and disables Door Lock Motor circuit.

- Legend**
- L1 (Red)
 - L2 (Black)
 - Neutral
 - Sensors

CLEAN FINISHED DOOR LOCK ABOVE $575^{\circ} \pm 25^{\circ}$

L2 (BLK)

N (WH)

L1 (RED)

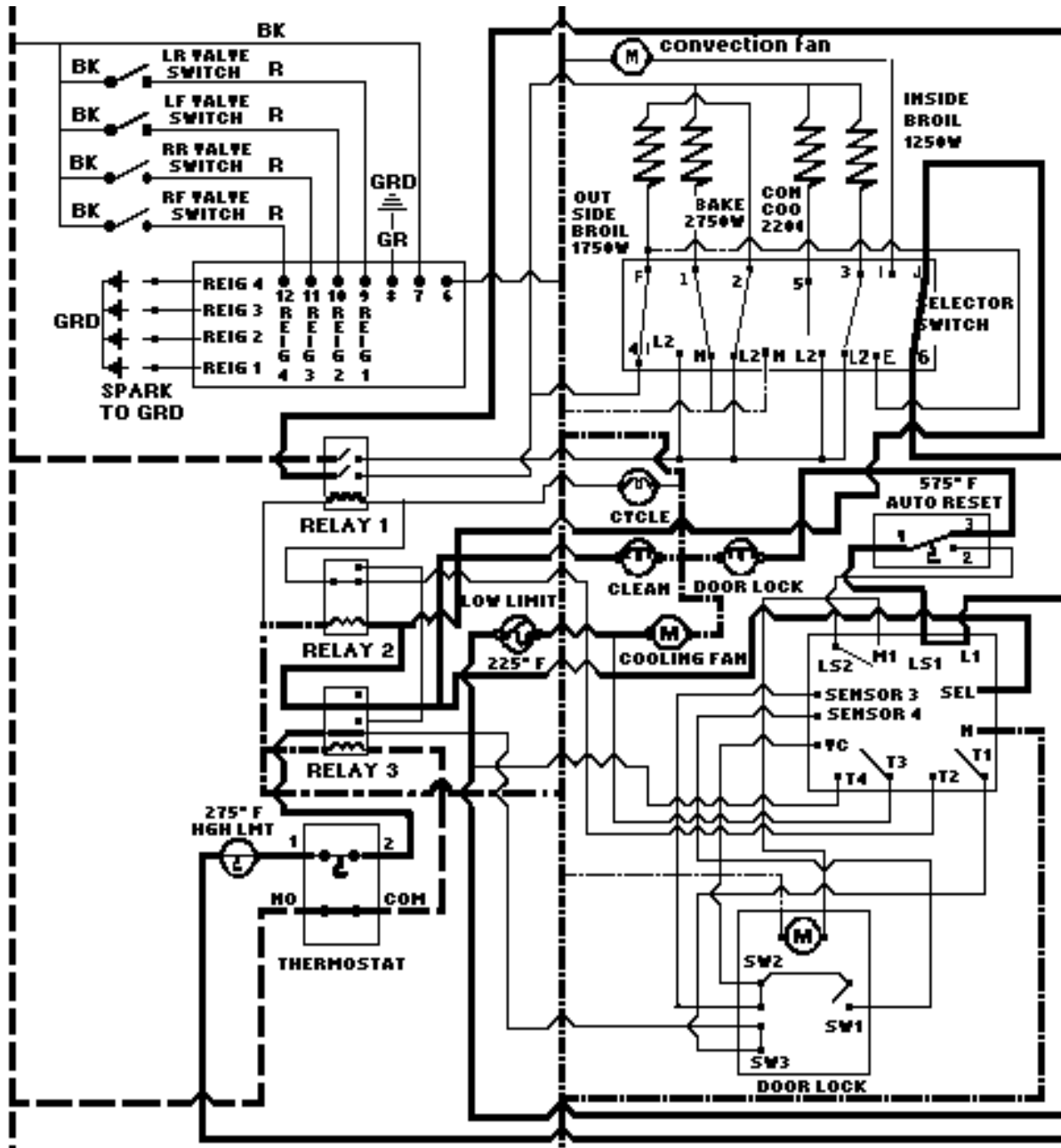

Timer Switches T3-T4, T1-T2 open, turning off the Cooling Fan, which will then be powered at 120v by the Fan Limit Switch when needed, and opening the circuit to Relay #1 which disables the Heating Elements. Switch LS2-M1 closes to power the Door Lock Motor.

Legend

- L1 (Red)
- - - L2 (Black)
- Neutral
- · - · Sensors

CLEAN FINISHED DOOR LOCK BELOW 575° ± 25°

L2 (BLK)

N (WH)

L1 (RED)

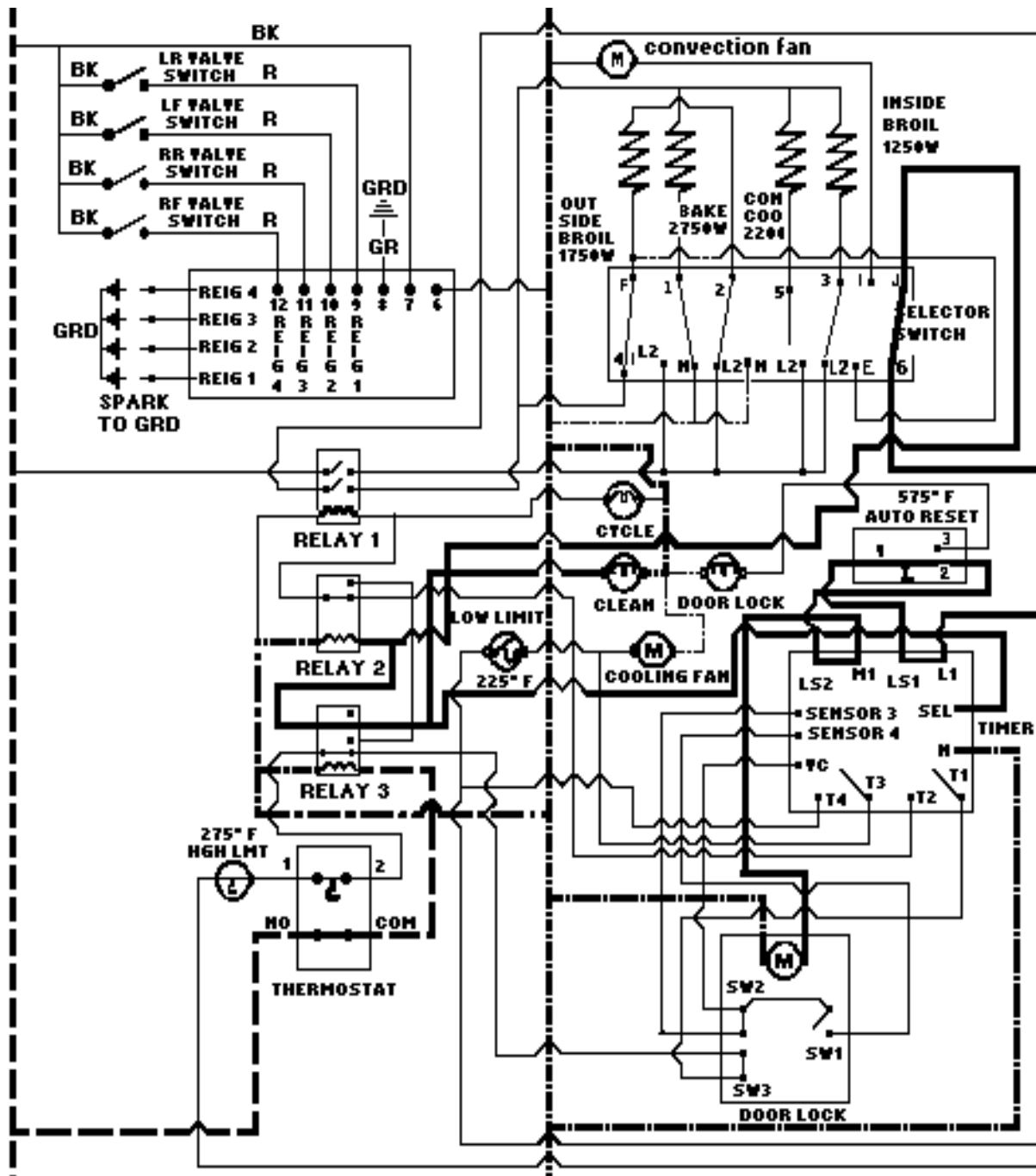

Auto Reset Switches 1-2 closed allowing the Door Lock Motor to operate and turning the Door Lock Light off. The Door Lock Motor operates until 2 seconds after Sensor 4 is signaled by VC that the Door Lock SW1 has been closed mechanically by the Door Lock bolt. The Door Lock / Timer switches LS2-M1 and LS1-L1 open and the Timer resets.

Legend

- L1 (Red)
- L2 (Black)
- Neutral
- Sensors

ELECTRICAL CONNECTION

Use a 3 - wire power supply cord kit rated for 30 amps - 125/250 volts for Models VDSC and VERT or 50 amps - 240 volts for Model VESC with closed loop terminals and marked for use with ranges. Where local codes do not permit grounding through neutral, use a 4 - wire power supply cord. The cord or conduit must be secured to the range with the strain relief bracket. The electrical connection is made at the terminal block, which is located behind the access door on the back of the range.

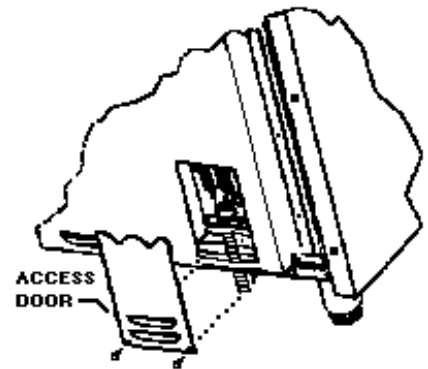

3 - Wire Power Supply Cord

1. Remove access door.
2. Remove supply cord strain relief bracket and 3 supply cord mounting screws on the terminal block.
3. Feed supply cord up through the hole in the bottom of range back.
4. Attach the line #1 (red) and line #2 (black) leads to the outside terminals and the neutral wire (white) to the center terminal on the terminal block.
5. Reattach supply cord strain relief bracket over supply cord, pushing supply cord up toward terminal block to relieve strain before tightening.
6. Reattach access door.

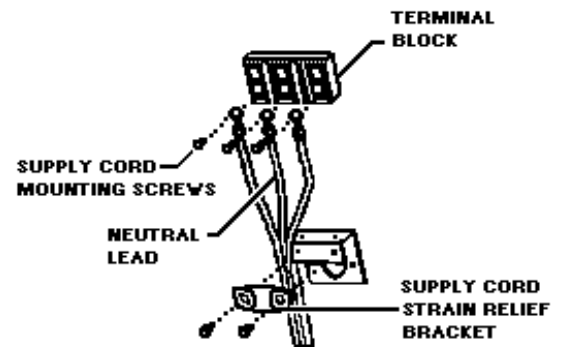

4 - Wire Power Supply Cord

1. Remove access door.
2. Remove supply cord strain relief bracket and 3 supply cord mounting screws on the terminal block.
3. Remove grounding screw; cut-off and discard ground strap.
4. Feed supply cord up through hole in the bottom of the range back.
5. Attach the ground lead (green) with the ground screw that was removed in step #3.
6. Attach the line #1 (red) and line #2 (black) leads to the outside terminals and the neutral wire (white) to the center terminal on the terminal block..
7. Reattach supply cord strain relief bracket over supply cord, pushing supply cord up towards terminal block to relieve strain before tightening.
8. Reattach access door.

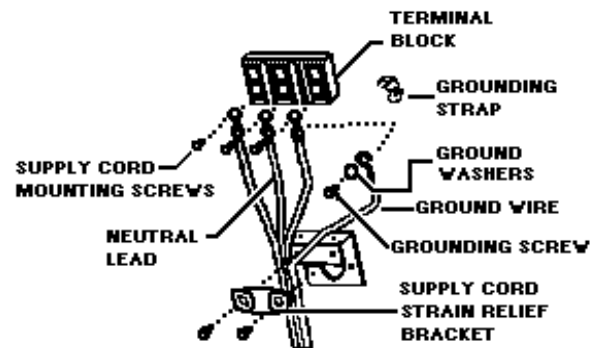

ELECTRICAL CONNECTIONS WITH CONDUIT

Use ½" trade size conduit with a conduit clamp, 12 AWG /600 volt copper conductor colored red for line # 1 and black for line # 2 and 14 AWG /600 volt copper conductor colored white for neutral with closed loop terminals marked for use with ranges. Where local codes do not permit grounding through neutral, use a green 12 AWG copper conductor as directed in the 4 - wire connector directions. The conduit must be secured to the range with the strain relief bracket. The electrical connection is made at the terminal block which is located behind the access door on the back of the range.

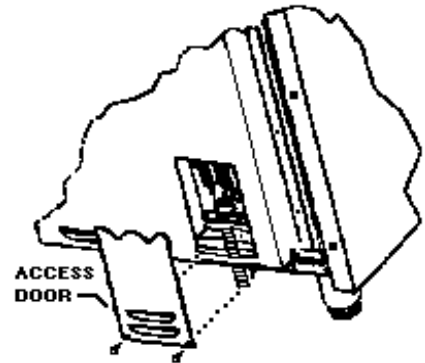

3 - Wire Power Connection

1. Remove access door.
2. Remove strain relief mounting angle and reattach as shown.
3. Feed ½" trade size conduit through the hole in the bottom of the range back and secure to the strain relief bracket with a conduit clamp.
4. Feed line #1 (red 12 AWG / 600v copper conductor), line #2 (black 12 AWG / 600v copper conductor), and neutral (white 14 AWG / 600v copper conductor) through conduit and attach closed loop terminals marked for use with ranges.
5. Remove 3 mounting screws and attach line #1 (red) to left terminal, line #2 (black) to the right terminal, and the neutral wire (white) to the center terminal.
6. Reattach the access door.

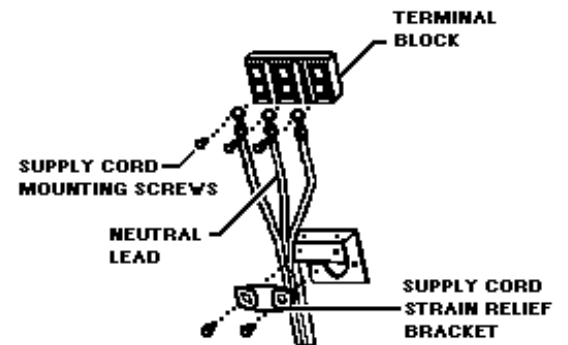

4 - Wire Power Connector

1. Remove access door.
2. Remove strain relief mounting angle and reattach as shown.
3. Feed 1½" trade size conduit through the hole in the bottom of the range back and secure to the strain relief bracket with a conduit clamp.
4. Feed line #1 (red 12 AWG / 600v copper conductor), line #2 (black 12 AWG / 600v copper conductor), neutral (white 14 AWG / 600v copper conductor), and a grounding wire (green 12 AWG copper conductor) through conduit and attach closed loop terminals marked for use with ranges. (Terminal is not required on grounding wire if used with ground washer).
5. Remove 3 mounting screws and green grounding screw. Cut-off and discard ground strap. Attach line #1 (red) to the left terminal, line #2 (black) to the right terminal, the neutral wire (white) to the center terminal and the copper ground wire to the green grounding screw using the ground washer.
6. Reattach the access door.

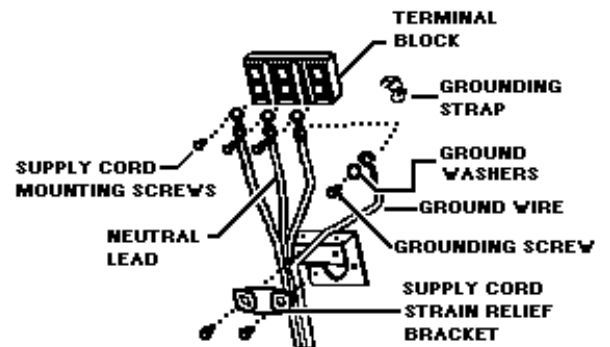

VDCS 305 BACK COVER ASSEMBLY

Remove the range from the cabinet and remove the back cover to service the electronic components for self clean.

- A. DISCONNECT THE VOLTAGE BEFORE REMOVING BACK COVER. (CAUTION 240 AC).
- B. A.C. Disconnect Cover.
- C. Back Cover

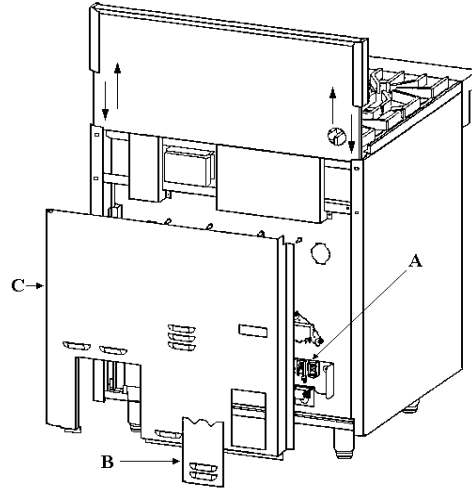

VDCS 305 REAR PANEL ASSEMBLY

- A. Relay (2)
- B. Cooling Fan
- C. Auto Reset
- D. Self Clean / Timer
- E. Convection Motor (serviced from inside the oven cavity).
- F. Oven Lights
- G. Oven Flue

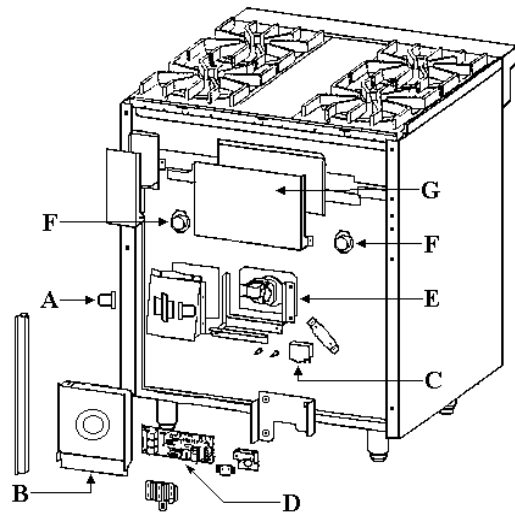

VDSC305 SELF CLEAN LOCK

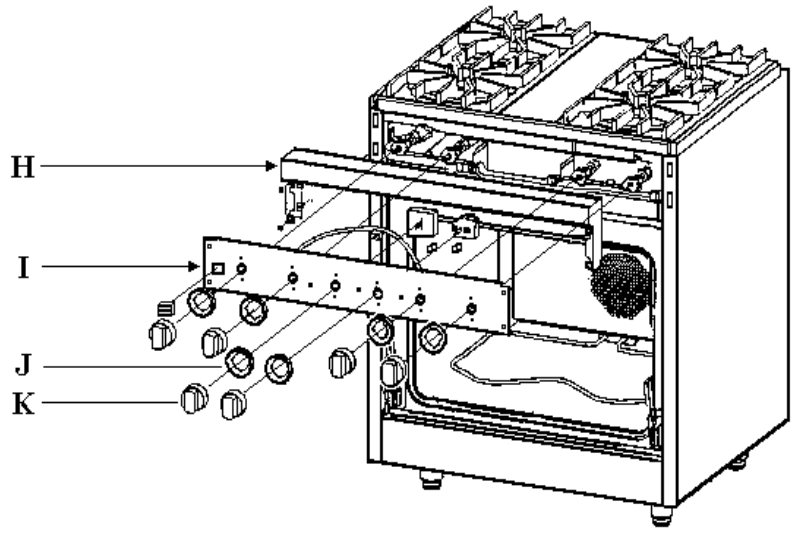
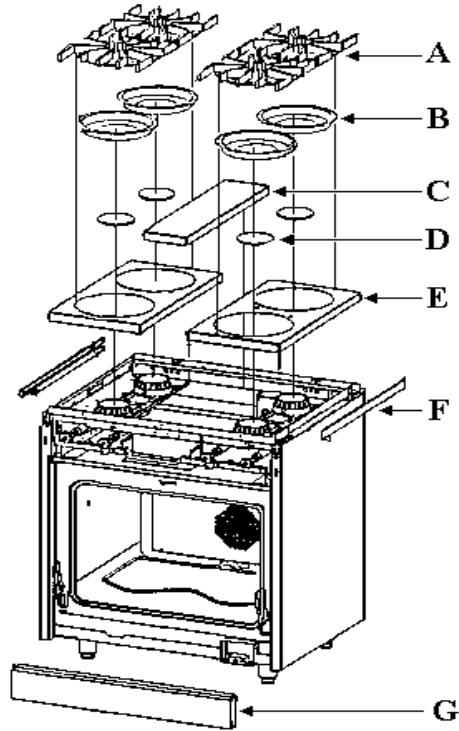

To replace the self clean lock mechanism you will need to remove:

- | | |
|------------------------|------------------|
| A. Burner Grates | G. Access Panel |
| B. Burner bowls | H. Landing Ledge |
| C. Center Work Space | I. Control Panel |
| D. Burner Caps | J. Knob Bezels |
| E. Grate Supports | K. Knobs |
| F. Grate Support Trims | |

VDSC 305 SELF CLEAN LOCK (Con't)

Remove both side panels and insulation.

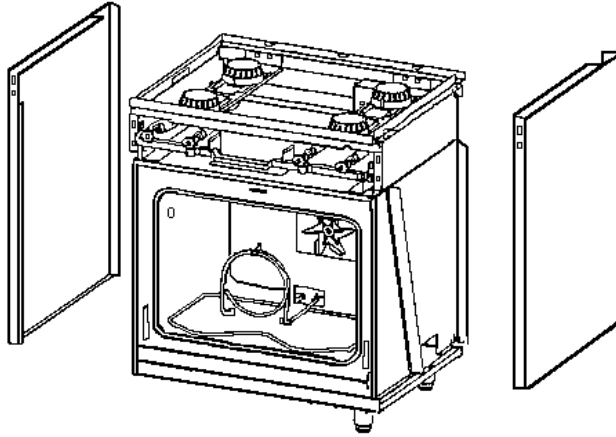

Remove the 6 screws along the upper frame above the door that hold the burner box assembly to the oven body. Lift the front of the burner box high enough to gain access to the **self clean lock** and associated components (High Limit Switch and Cooling Fan Switch). Use a block, approximately 6" high, to hold the burner box in place while working on the lock.

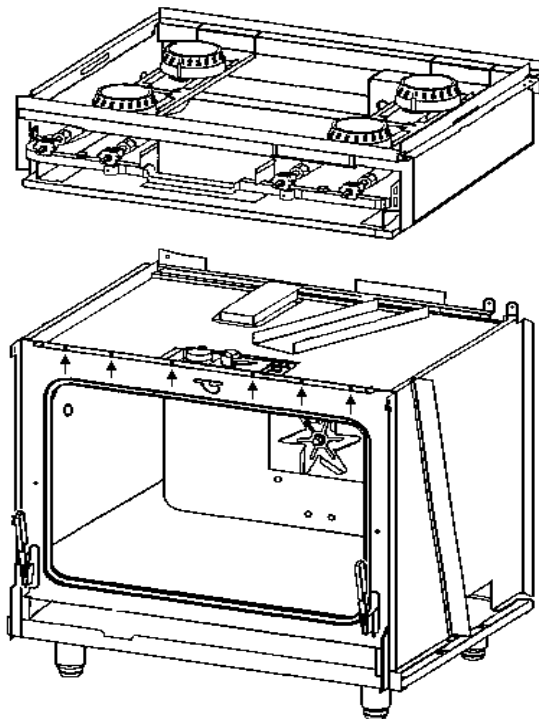

VDSC “LOCKED “ DOOR

In the unlikely event the door lock motor should fail in the “Locked “ position you will need:

1. To fashion a hook on the end of a 12" long stiff wire.
2. Insert the hook between the door and the front frame assembly at the top, see “A” illustrated at right. The hook on the wire should be to the right of the latch hook.
3. Engage the door latch hook with the wire hook and pull the latch hook to the left until the door is released, see illustration below.

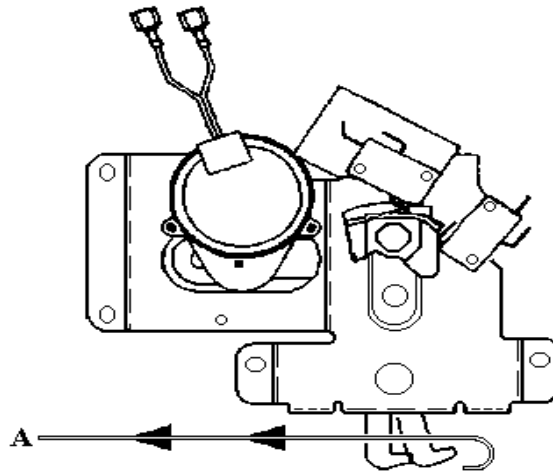
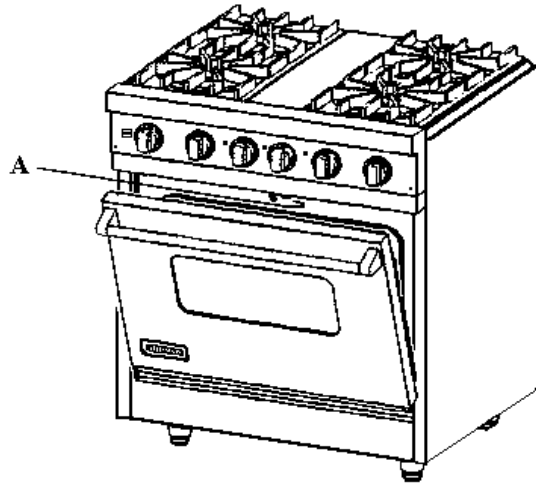

VERT AND VESC (TOP)

TOP REMOVAL

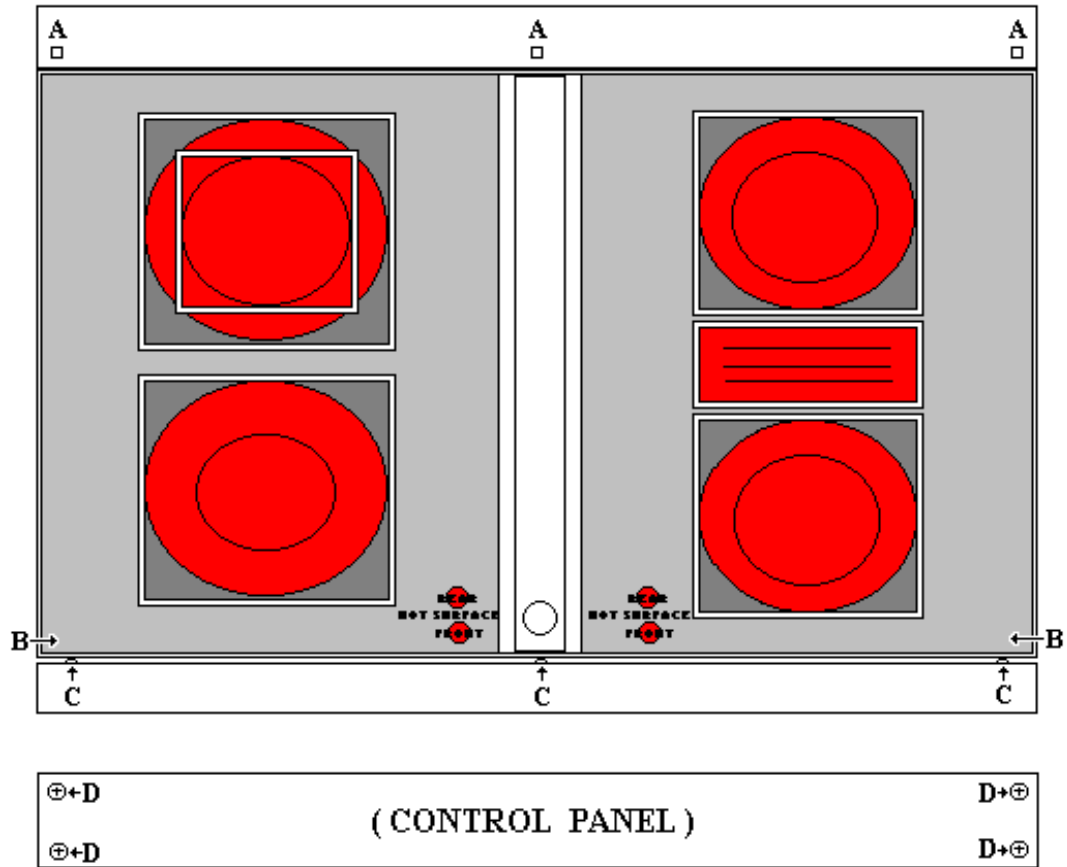

ILLUSTRATION "1"

1. To remove the smooth glass top:
 - (A) Pull the range (rang-top) forward to remove the screws holding the back-guard in place.
 - (B) Remove the back-guard.
 - (C) Remove the 3 screws "A" holding the top to the frame.
 - (D) Remove the 4 screws "D" and lower the control panel.
 - (E) Remove the 2 screws "B" beneath front corners.
 - (F) Remove the glass top.
 - (G) Restore the range (range-top) by reversing procedures above.
2. To remove the landing ledge the above procedure will have to be followed in order to remove the 3 "C" screws on the back side of the landing ledge.

Left Rear (Dual Element) Burner

2400W / 1000W @ 240vac 10A / 4.2A
 1800W / 750W @ 208vac 8.7A / 3/6A

Left Front Burner

1500W @ 240vac 6.3A
 1125W @ 208vac 5.4A

Right rear Burner

1800W @ 240vac 7.5A
 1350W @ 208vac 6.5A

Bridge Heater

800W @ 240vac 3.4A
 600W @ 208vac 2.9A

Right Front Burner

1800W @ 240vac 7.5A
 1350W @ 208vac 6.5A

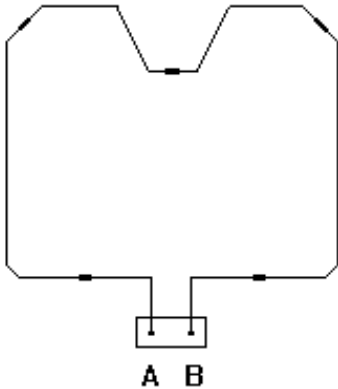
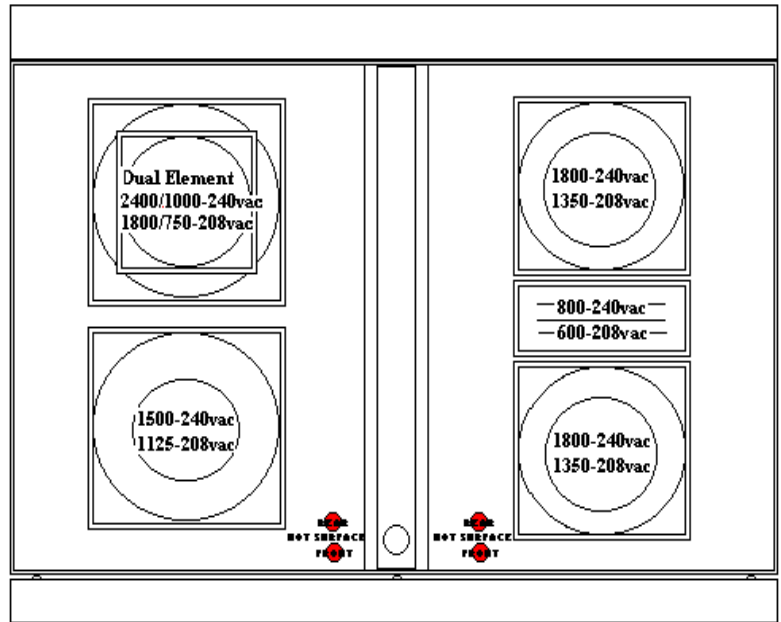

Bake Element: "A" to "B" 21.1 ohms
 "A" to "B" 240vac during bake and convection bake.
 120vac during self-clean
 2935 Watts @ 240vac 12.2 amps
 2205 Watts @ 208vac 10.6 amps

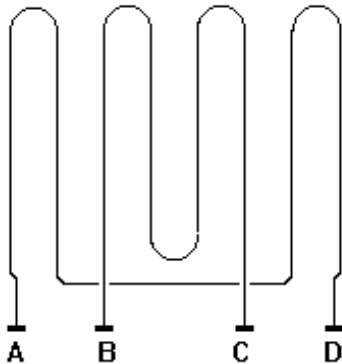

Broil Element: "A" to "D" (outside element) 32.6 ohms
 "A" to "D" 50vac during bake and convection bake
 240vac during maxi broil
 240vac during convection broil
 240vac during self-clean
 "B" to "C" (inside element) 45.2 ohms
 "B" to "C" 70vac during bake and convection bake
 240vac during mini broil
 240vac during maxi broil
 240vac during convection broil
 240vac during self-clean
 Maxi broil 3000 Watts @ 240vac 12.5 amps
 2255 Watts @ 208vac 10.8 amps
 Mini broil 1250 Watts @ 240vac 5.2 amps
 940 Watts @ 208vac 4.5 amps

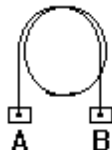

Convection Element: "A" to "B" 26 ohms
 "A" to "B" 240vac during convection cook
 2200 Watts @ 240vac 9.2 amps
 1650 Watts @ 208vac 7.9 amps

Filename: SCLEAN29.doc
Directory: D:\VBCODE\IPLUTILS\PDFGenerator\InputData\F90556 Selfclean-VDSC-VESC-VERT TOP
Template: C:\Documents and Settings\tomw.EYECOM\Application Data\Microsoft\Templates\Normal.dot
Title: Left Rear (Dual Element) Burner
Subject:
Author: Viking Range
Keywords:
Comments:
Creation Date: 7/6/2001 11:52 AM
Change Number: 4
Last Saved On: 3/28/2003 3:47 PM
Last Saved By: Ken Sievert
Total Editing Time: 13 Minutes
Last Printed On: 3/28/2003 5:54 PM
As of Last Complete Printing
Number of Pages: 2
Number of Words: 255 (approx.)
Number of Characters: 1,458 (approx.)