

KitchenAid

TECHNICAL EDUCATION

ELECTRONIC TOUCH CERAMIC COOKTOP

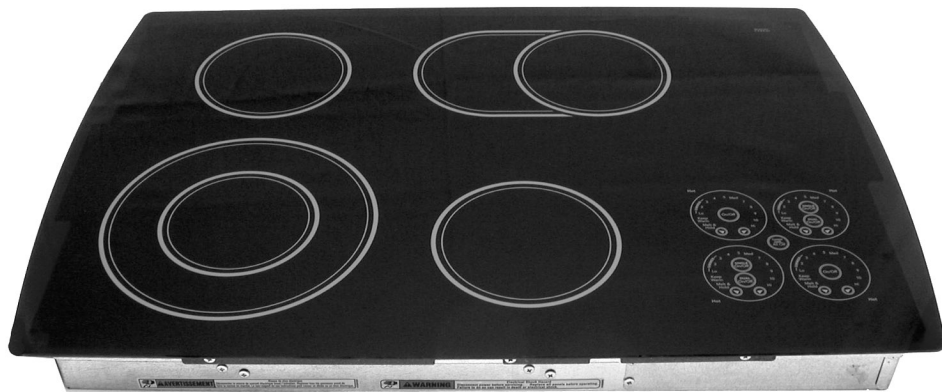

Models KECC508MBL & KECC568MBL

FORWARD

This KitchenAid Job Aid, “Electronic Touch Ceramic Cooktop,” (Part No. 4317347), provides the technician with information on the installation, operation, and service of the Electronic Touch Ceramic Cooktop. It is to be used as a training Job Aid and Service Manual. For specific information on the model being serviced, refer to the “Use and Care Guide,” or “Wiring Diagram” provided with the cooktop.

The Wiring Diagrams and Strip Circuits used in this Job Aid are typical and should be used for training purposes only. Always use the Wiring Diagram supplied with the product when servicing the unit.

GOALS AND OBJECTIVES

The goal of this Job Aid is to provide detailed information that will enable the service technician to properly diagnose malfunctions and repair the KitchenAid Electronic Touch Ceramic Cooktop.

The objectives of this Job Aid are to:

- Understand and follow proper safety precautions.
- Successfully troubleshoot and diagnose malfunctions.
- Successfully perform necessary repairs.
- Successfully return the cooktop to its proper operational status.

WHIRLPOOL CORPORATION assumes no responsibility for any repairs made on our products by anyone other than Authorized Service Technicians.

TABLE OF CONTENTS

	Page
GENERAL	1-1
Safety First.....	1-1
Model & Serial Number Designations.....	1-3
Model & Serial Number Label, Tech Sheet, And Wiring Diagram Locations.....	1-4
Specifications.....	1-5
KitchenAid Cooktop Warranty.....	1-6
INSTALLATION INFORMATION	2-1
Product Dimensions.....	2-1
Cutout Dimensions/Requirements	2-2
Junction Box Wiring	2-3
THEORY OF OPERATION	3-1
Touch Control Circuit	3-1
Element Limiter	3-1
Fault Code Diagnosis	3-1
Electronic Control Board Circuit Monitoring.....	3-2
COMPONENT ACCESS	4-1
Component Locations	4-1
Removing The Cooktop Glass	4-2
Removing An Element And Limiter	4-3
Removing The User Interface And Electronic Control Boards.....	4-4
Removing The Power Supply Wiring	4-6
COMPONENT TESTING	5-1
LF (Dual) Element.....	5-1
RR (Dual) Element.....	5-1
RF & LR Elements	5-2
DIAGNOSIS & TROUBLESHOOTING	6-1
Diagnosis—Failure Codes	6-1
Troubleshooting Chart	6-4
WIRING DIAGRAMS & STRIP CIRCUITS	7-1
Wiring Diagram—#8285516	7-1
Strip Circuits—#8285516.....	7-2
Wiring Diagram—#8285517	7-3
Strip Circuits—#8285517	7-4

— NOTES —

GENERAL SAFETY FIRST

Your safety and the safety of others is very important.

We have provided many important safety messages in this Job Aid and on the appliance. Always read and obey all safety messages.



This is the safety alert symbol.

This symbol alerts you to hazards that can kill or hurt you and others.

All safety messages will follow the safety alert symbol and either the word "DANGER" or "WARNING." These words mean:

! DANGER

You can be killed or seriously injured if you don't immediately follow instructions.

! WARNING

You can be killed or seriously injured if you don't follow instructions.

All safety messages will tell you what the potential hazard is, tell you how to reduce the chance of injury, and tell you what can happen if the instructions are not followed.

! WARNING



Electrical Shock Hazard

Disconnect power before servicing.

Replace all parts and panels before operating.

Failure to do so can result in death or electrical shock.

! WARNING



Electrical Shock Hazard

Connect green ground wire to ground screw.

Failure to do so can result in death or electrical shock.

ELECTROSTATIC DISCHARGE (ESD) SENSITIVE ELECTRONICS

ESD problems are present everywhere. ESD may damage or weaken the electronic control assembly. The new control assembly may appear to work well after repair is finished, but failure may occur at a later date due to ESD stress.

- Use an antistatic wrist strap. Connect the wrist strap to a green ground connection point or unpainted metal in the appliance; or touch your finger repeatedly to a green ground connection point or unpainted metal in the appliance.
- Before removing the part from its package, touch the antistatic bag to a green ground connection point or unpainted metal in the appliance.
- Avoid touching electronic parts or terminal contacts. Handle the electronic control assembly by the edges only.
- When repackaging the failed electronic control assembly in an antistatic bag, observe the previous instructions.

MODEL & SERIAL NUMBER DESIGNATIONS

MODEL NUMBER

SERIAL NUMBER		K	EC	C	50	8	M	BL	0
K = KitchenAid Brand									
PRODUCT IDENTIFICATION									
EC = Electric Cooktop									
GC = Gas Cooktop									
MERCHANDISING SCHEME									
C = Ceramic									
D = Downdraft Vent									
E = Electronics									
G = Grill / Griddle									
M = Modular / Downdraft									
N = International Collection									
P = Commercial									
S = Standard / Porcelain Metal									
T = Tempered Glass									
V = VBL Proline Series									
X = 208 Volts									
CAPACITY / SIZE / SERIES / CONFIGURATION									
1ST POSITION		2ND POSITION							
0 = 2 Burner / Element System		0 = 30" Wide							
1 = Standard		2 = 42" OR 12" Wide							
2 = Grill / Griddle		3 = 33" Wide							
3 = Temp. Glass		5 = 15" Wide							
4 = Commercial		6 = 36" Wide							
5 = Ceramic Glass		8 = 48" Wide							
8 = Modular / Downdraft									
FEATURES									
0 = Standard Elements / Burners									
1 = Radiant Elements									
2 = Dual Elements Or Sealed Burners With Grill									
3 = Sealed Burners With Griddle									
4 = Sealed Burners With Grill & Griddle									
5 = Sealed Burners / Cast Elements Or Triple Tier									
6 = 5 Burners / Elements									
7 = Halogen Elements / Or 6 Burners									
8 = Touch Controls									
9 = Induction									
YEAR OF INTRODUCTION									
M = 2003									
COLORS									
WW = White		SS = Stainless							
BL = Black		BB = Biscuit							
ENGINEERING CHANGE									
0 = Basic Release, 1 = First Revision, etc.									

SERIAL NUMBER

SERIAL NUMBER	X	P	39	10015
MANUFACTURING SITE				
X = OXFORD				
YEAR OF PRODUCTION				
P = 2003				
WEEK OF PRODUCTION				
PRODUCT SEQUENCE NUMBER				

MODEL & SERIAL NUMBER LABEL, TECH SHEET, AND WIRING DIAGRAM LOCATIONS

The Model/Serial Number label, Tech Sheet, and Wiring Diagram locations are shown below.

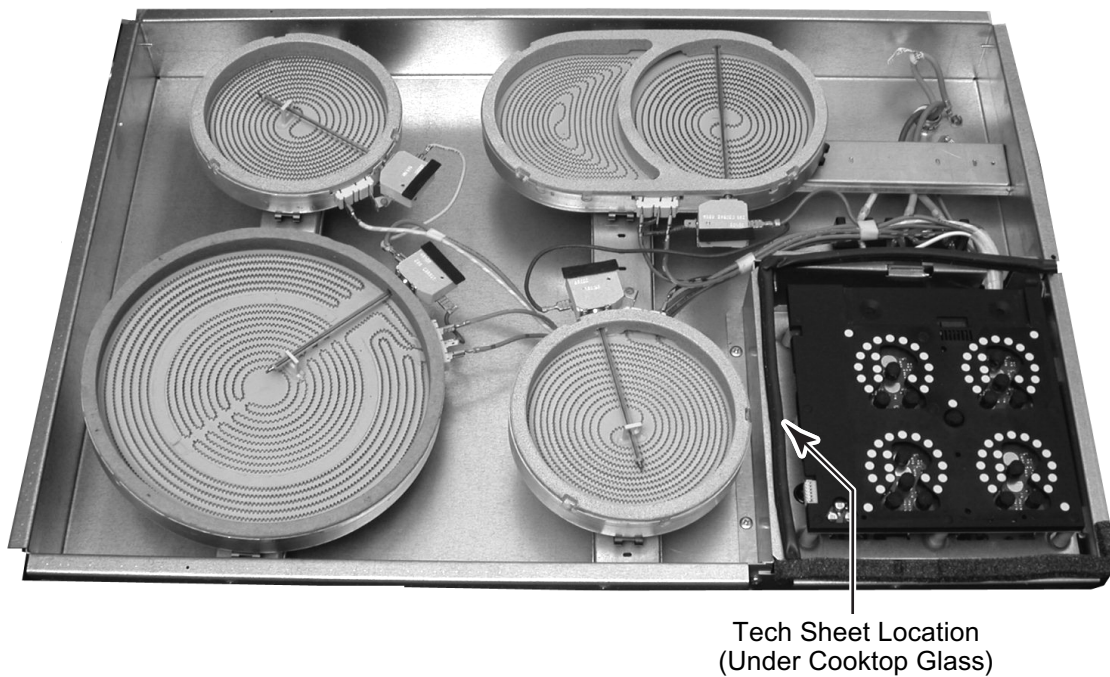
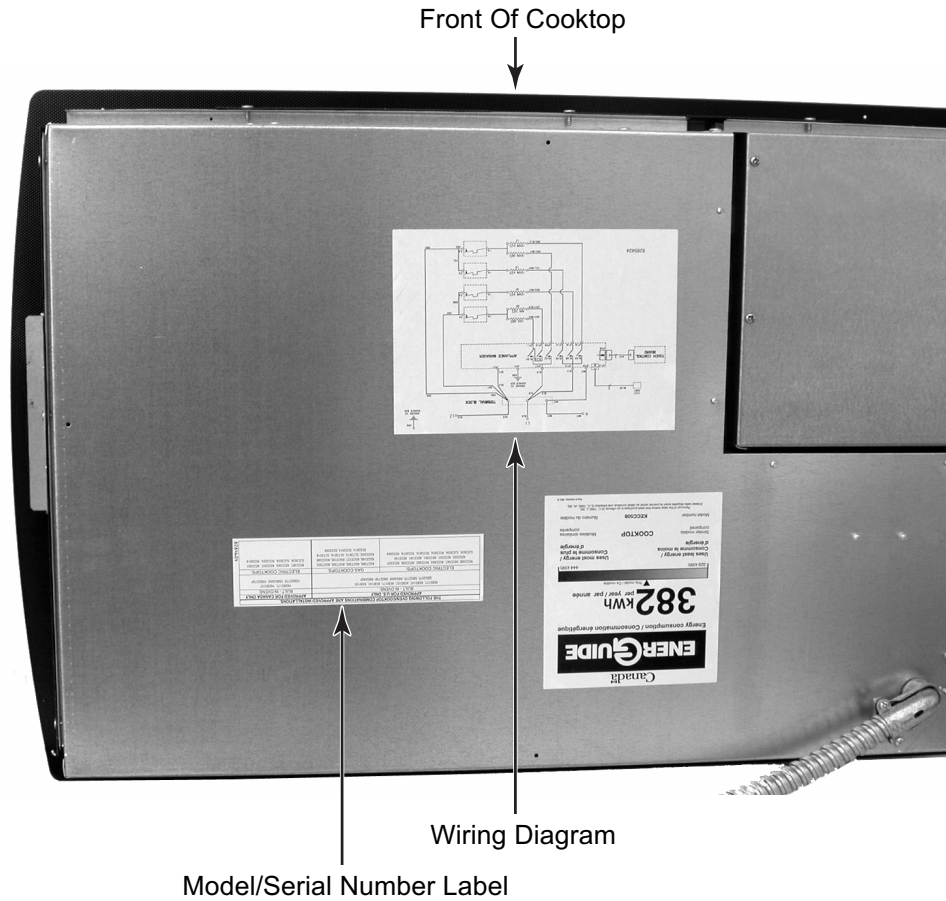

SPECIFICATIONS

Model Number	KECC508MBL	KECC568MBL
Model		
Model Description	Electronic Touch Ceramic Cooktop	Electronic Touch Ceramic Cooktop
Size-Configuration	30"	36"
Dimensions/Specifications		
Exterior Dimensions		
Overall Height (in)	3 1/16"	3 1/16"
Overall Width (in)	30" (F); 31 1/2" (M)	36" (F); 37 1/2" (M)
Overall Depth (in)	21"	21"
Cutout Dimensions		
Cutout Height (in) (Measure Or Min/Max)	2 7/8"	2 7/8"
Cutout Width (in) (Measure Or Min/Max)	29 1/2"	35 1/2"
Cutout Depth (in) (Measure Or Min/Max)	20 1/2"	20 1/2"
Net Weight (lbs)	30	35
Ratings		
Electric Voltage/Phase/Frequency (Hz)	240/208 Volt,Single Phase,60Hz	240/208 Volt,Single Phase,60Hz
Total Connected Load In kW:		
240 Volts (Preferred)	6.6 kw	8.1 kw
208 Volts	4.9 kw	6.1 kw
Circuit Amps	30 AMP	40 AMP
Exterior		
Comment (Finish)	Ceramic Glass	Ceramic Glass
Cooktop Color	Black	Black
Cooktop Trim Material		
Cooktop Trim Color		
Cooktop Control Type	Electronic Touch	Electronic Touch
Cooktop Control Location	Right Corner	Right Corner
Cooktop Control #	4	5
Control Area:		
Control Area Color	Basalt Grey	Basalt Grey
Electronic Control	Yes	Yes
Melt & Hold	Yes - All burners	Yes - All burners
Keep Warm	Yes - All burners	Yes - All burners
Simmer Settings	Yes - 3 Settings, All burners	Yes - 3 Settings, All burners
Cooktop Indicator Light	Single Element: 1 Indicator; Dual Element: 2 Indicators	Single Element: 1 Indicator; Dual Element: 2 Indicators
Hot Surface Indicator	4	5
Electric Element Configuration:		
Ele R Front Size & Type	Radiant	Radiant
Ele RF Output (W@240/208V)	1200W/900W	1200W/900W
Ele L Front Size & Type	Dual Round - 2400W/1000W	Dual Round - 2400W/1000W
Ele LF Output (W@240/208V)	2400W/1800W	2400W/1800W
Ele R Rear Size & Type	Radiant	Radiant
Ele RR Output (W@240/208V)	1800W/1350W	1200W/900W
Ele L Rear Size & Type	Radiant	Radiant
Ele LR Output (W@240/208V)	1200W/900W	1500W/1125W
Ele C Rear Size & Type		Radiant
Ele CR Output (W@240/208V)		1800W/1350W
Interior		
Accessories		
Other Accessory	Yes	Yes
Comment	Ceramic Glass Polish, 4456147	Ceramic Glass Polish, 4456147
Miscellaneous		
Product Literature:		
Installation Instructions Part/Comment	8285316	8285316
Service Manual Part/Comment	4317347	4317347
Tech Sheet Part/Comment	8285516	8285516
Use & Care Guide Part/Comment	8285368	8285368
Other	Cooking Tips 3191638	Cooking Tips 3191638
Agency Approvals	UL,CSA	UL,CSA
Approved to Install Over BI Oven:		
Hardware	Yes	Yes
Power Cord Length & # Wires	3 1/2 Foot/3 Wire	3 1/2 Foot/3 Wire
Residential Use Only	Yes	Yes
Warranty	Yes	Yes
Full	12 Mo	12 Mo
Extended:		
Ceramic Glass Cooking Surface	60 Mo	60 Mo
Electronic Controls	60 Mo	60 Mo

KITCHENAID COOKTOP WARRANTY

ONE-YEAR FULL WARRANTY

For one year from the date of purchase, when this appliance is operated and maintained according to instructions attached to or furnished with the product, KitchenAid will pay for factory specified parts and repair labor costs to correct defects in materials or workmanship. Service must be provided by a KitchenAid designated service company.

SECOND THROUGH FIFTH YEAR LIMITED WARRANTY ON ELECTRIC ELEMENTS, CERAMIC GLASS COOKTOP, GAS BURNERS, AND SOLID STATE TOUCH CONTROL SYSTEM

On electric ranges and electric cooktops, in the second through fifth years from the date of purchase, when this appliance is operated and maintained according to instructions attached to or furnished with the product, KitchenAid will pay for factory specified parts for any electric element to correct defects in materials or workmanship.

On ceramic glass ranges and ceramic glass cooktops, in the second through fifth years from the date of purchase, when this appliance is operated and maintained according to instructions attached to or furnished with the product, KitchenAid will pay for factory specified parts for the ceramic glass cooktop. KitchenAid warrants that the ceramic glass cooktop will not discolor, the cooktop pattern will not wear off, the rubber seal between the ceramic glass cooktop and porcelain edge will not crack, the ceramic glass cooktop will not crack due to thermal shock and the surface unit elements will not burn out.

KitchenAid will not pay for:

1. Service calls to correct the installation of your appliance, to instruct you how to use your appliance, to replace house fuses or correct house wiring, or to replace owner-accessible light bulbs.
 2. Repairs when your appliance is used in other than normal, single-family household use.
 3. Pickup and delivery. Your appliance is designed to be repaired in the home.
 4. Damage resulting from accident, alteration, misuse, abuse, fire, flood, improper installation, acts of God or use of products not approved by KitchenAid.
 5. Repairs to parts or systems resulting from unauthorized modifications made to the appliance.
 6. Replacement parts or repair labor costs for units operated outside the United States and Canada.
 7. Any labor costs during the limited warranty periods.
-

KITCHENAID AND KITCHENAID CANADA SHALL NOT BE LIABLE FOR INCIDENTAL OR CONSEQUENTIAL DAMAGES.

Some states or provinces do not allow the exclusion or limitation of incidental or consequential damages, so this exclusion or limitation may not apply to you. This warranty gives you specific legal rights, and you may also have other rights which vary from state to state or province to province.

Outside the United States and Canada, this warranty does not apply. Contact your authorized KitchenAid dealer to determine if another warranty applies.

If you need service, first see the "Troubleshooting" section in this Job Aid. After checking "Troubleshooting," additional help can be found by checking the "Assistance or Service" section in the Use & Care Guide, or by calling the KitchenAid Customer Interaction Center, **1-800-422-1230** (toll-free), from anywhere in the U.S.A., and **1-800-807-6777** from anywhere in Canada.

INSTALLATION INFORMATION

PRODUCT DIMENSIONS

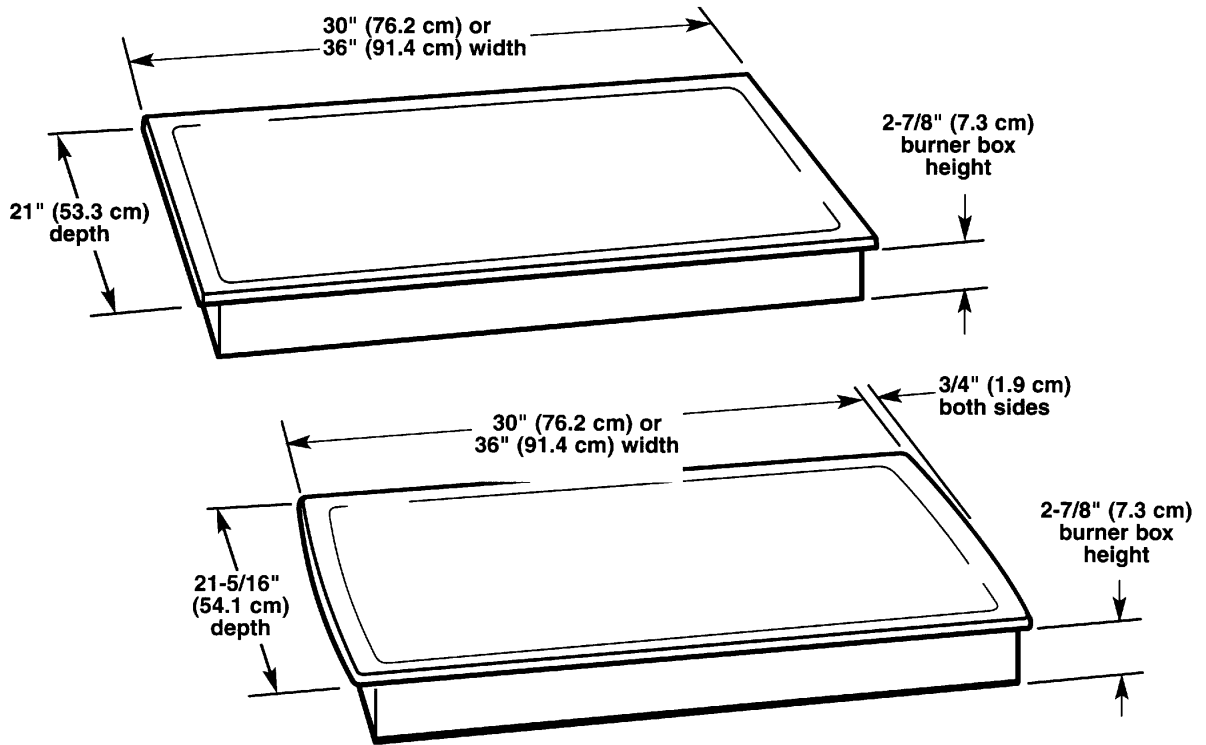

CUTOUT DIMENSIONS / REQUIREMENTS

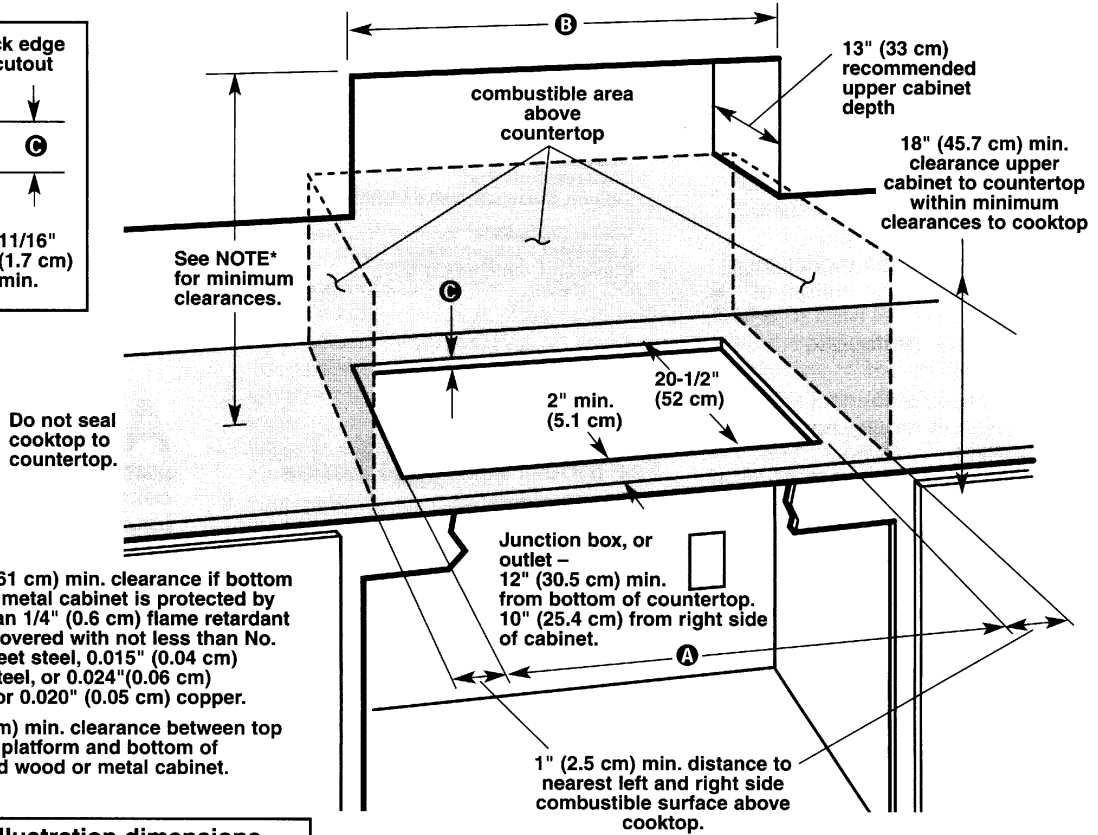
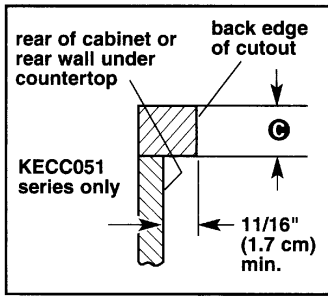

* Note: 24" (61 cm) min. clearance if bottom of wood or metal cabinet is protected by not less than 1/4" (0.6 cm) flame retardant millboard covered with not less than No. 28 MSG sheet steel, 0.015" (0.04 cm) stainless steel, or 0.024" (0.06 cm) aluminum or 0.020" (0.05 cm) copper.
30" (76.2 cm) min. clearance between top of cooking platform and bottom of unprotected wood or metal cabinet.

Illustration dimensions

Cooktop width	A	B	C
15" (38.1 cm)	14-1/2" (36.6 cm)	15" (38.1 cm)	1-1/2" max (3.8 cm)
30" (76.2 cm)	29-1/2" (75 cm)	30" (76.2 cm)	—
36" (91.4 cm)	35-1/2" (90.2 cm)	36" (91.4 cm)	—

Important note on base cabinet construction: After making the countertop cutout, some installations may require notching down the base cabinet side walls to clear the burner box. To avoid this modification, use a base cabinet having sidewalls wider than the cutout.

Note: If cabinet has a drawer, a 3" (7.5 cm) depth clearance from the countertop to the top of the drawer (or other obstruction) in base cabinet is required.

JUNCTION BOX WIRING

⚠ WARNING



Electrical Shock Hazard

Turn power supply off before connecting wires.

Use 8-gauge solid copper wire.

Electrically ground cooktop.

Failure to follow these instructions can result in death, fire, or electrical shock.

This cooktop must be connected to a grounded, metallic permanent wiring system or a ground connector should be connected to the ground terminal or wire lead on the cooktop.

This cooktop is manufactured with a frame connected, green or bare ground wire. Connect the cooktop cable to the junction box through the U.L.- or CSA-listed conduit connector. Complete electrical connection according to local codes and ordinances.

For all cooktop models with three-wire cable from the cooktop:

3-Wire Ungrounded Neutral

Where local codes **DO NOT** permit connecting the frame-ground conductor to the neutral (white) junction box wire (used for Canadian installations).

1. Disconnect power supply.
2. Connect the flexible, armored cable from the cooktop to the junction box using a U.L.- or CSA-listed conduit connector. Tighten the screws on the conduit connector.
3. Connect the two black wires together; then connect the two red wires together using a twist-on connector.
4. Connect the green or bare ground wire from the cooktop cable to the grounded wire in the junction box, or other grounded connector using a twist-on connector.
5. Install a twist-on connector on the end of the single white wire. **DO NOT connect the bare ground wire to the neutral (white) wire in the junction box.**

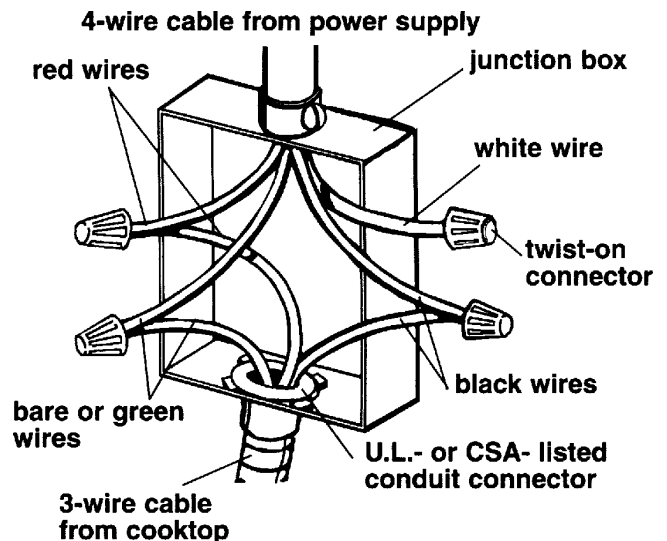

3-Wire Grounded Neutral

Where local codes permit connecting the frame-ground conductor to the neutral (white) junction box wire (not used for Canadian installations):

1. Disconnect power supply.
2. Connect the flexible, armored cable from the cooktop to the junction box using a U.L.- or CSA-listed conduit connector. Tighten the screws on the conduit connector.
3. Connect the bare cooktop wire to the white wire using a twist-on connector.
4. Connect the two red wires together, and the two black wires together using twist-on connectors.

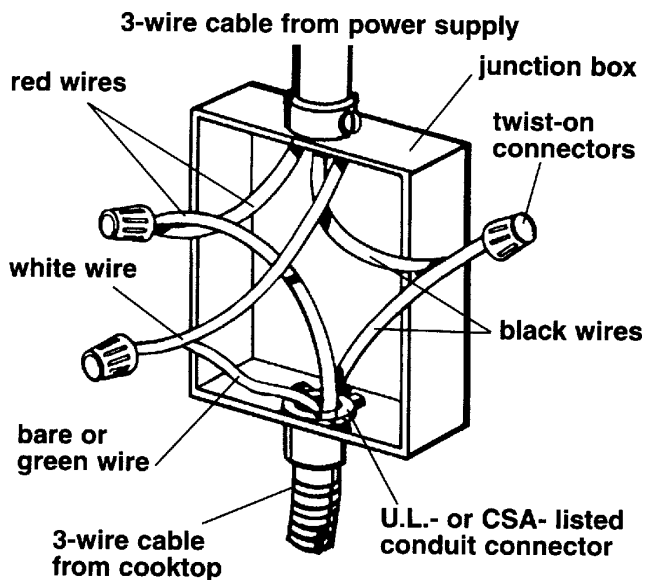

For all cooktop models with four-wire cable from the cooktop. (These cooktops are manufactured with white (neutral) power supply wire and a cabinet-connected bare ground wire factory-crimped together.):

4-Wire Ungrounded Neutral

Where local codes **DO NOT** permit connecting the frame-ground conductor to the neutral (white) junction box wire (used for Canadian installations):

1. Disconnect power supply.
2. Connect the flexible, armored cable from the cooktop to the junction box using a U.L.- or C.S.A.-listed conduit connector. Tighten the screws on the conduit connector.
3. Connect the two black wires together, then connect the two red wires together using twist-on connectors.
4. Separate the factory-crimped bare and white cooktop cable wires.
5. Connect the two white wires together using a twist-on connector.
6. Connect the bare ground wire from the cooktop cable to the grounded wire in the junction box, or other grounded connector, using a twist-on connector. **DO NOT connect the bare ground wire to the neutral (white) wire in the junction box.**

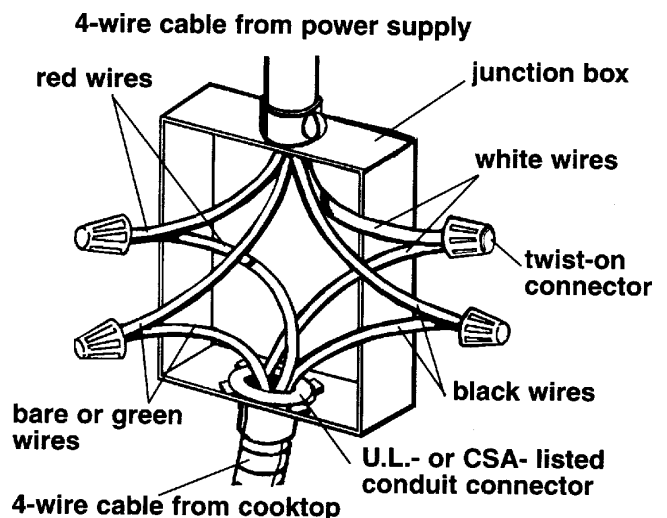

4-Wire Grounded Neutral

Where local codes permit connecting the frame-ground conductor to the neutral (white) junction box wire (not used for Canadian installations):

1. Disconnect power supply.
2. Connect the flexible, armored cable from the cooktop to the junction box using a U.L.- or C.S.A.-listed conduit connector. Tighten the screws on the conduit connector.
3. Connect the following wires together using twist-on connectors:
 - Two black wires
 - Two red wires
 - The factory-crimped bare and white cooktop cable wires to the white (neutral) wire in the junction box.

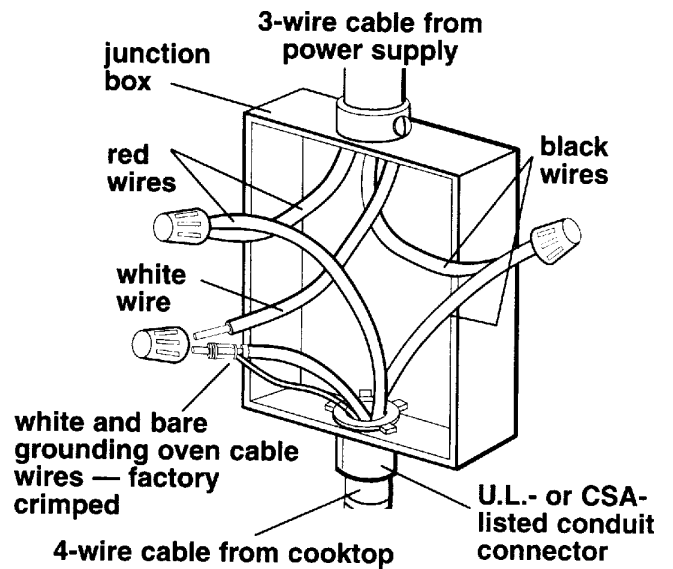

— NOTES —

THEORY OF OPERATION

TOUCH CONTROL CIRCUIT

Refer to the strip circuit below.

Whenever a cooktop glass “touch panel” is touched, an electrical signal is sent to the Electronic Control (LEO) Board through a connection cable. The electrical signal closes the appropriate relay on the control, and applies 240 volts to the heating element from the L1 side of the AC line. Current travels from the element to the limiter, which monitors the temperature of the cooktop glass. The circuit is completed from the limiter to the L2 side of the line.

ELEMENT LIMITER

Refer to the strip circuit below.

Limiters on standard cooktops utilize two switches to control two different safety features. One switch monitors the maximum heat produced by the burner, and protects the cooktop glass from overheating. The other switch monitors the burner operation, and uses a hot surface indicator light to indicate when the cooktop surface is hot and unsafe to touch.

The element limiter on the Tap Touch Cooktop is different from standard cooktop limiters, because only one limiter switch is required. This switch monitors the maximum heat produced

by the burner, and protects the cooktop glass from overheating. The hot surface indicator light is controlled by a programmed sequence stored in the microcomputer board. The indicator lights will be activated, based on the amount of time the burner is on. The hot surface indicator light remains on during the entire operation of the burner, and during the cool-down period of the cooktop glass. The indicator light “on time” will last beyond the time that the burner is turned off. As the burner is turned off, the microcomputer calculates the time that the cooktop will take to cool down, and keeps the light glowing during that time. If there is a power outage during this “calculation time,” the microcomputer will retain the calculated time. When power is re-applied, the countdown time will continue, and the indicator light(s) will remain on until the countdown is completed.

FAULT CODE DIAGNOSIS

The Electronic Control constantly checks the operation of the cooktop circuitry. If a problem occurs, a “fault code” will be generated at the two front burner controls. The fault code is a combination of glowing LEDs that indicate a specific “fault code” number (see page 6-1 for a description of the Fault Code LEDs).

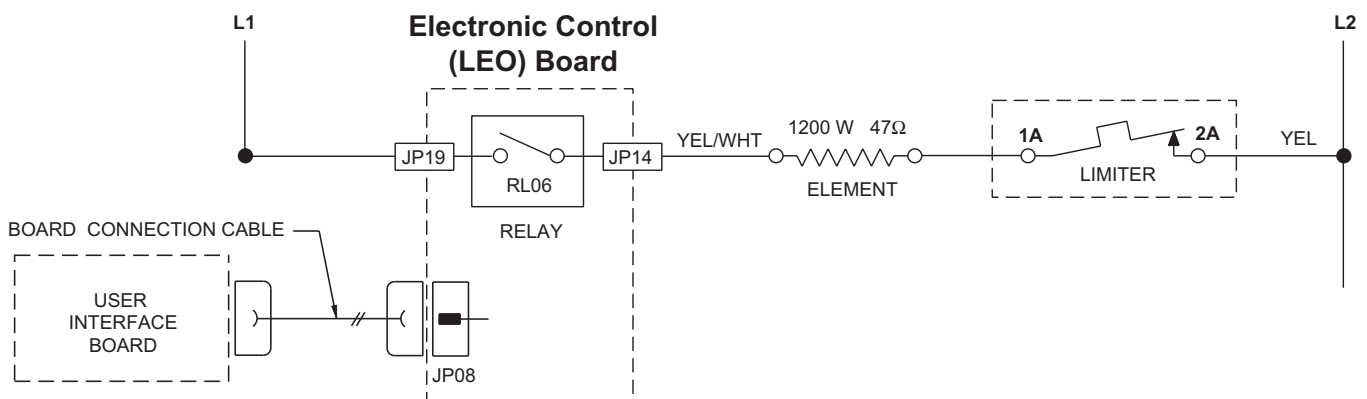

ELECTRONIC CONTROL BOARD CIRCUIT MONITORING

The Electronic Control Board on this cooktop has a green glowing LED that is used as a visual indicator to show that all of the circuitry is operating properly.

The board monitors the operation of the:

- Central Processing Unit (CPU)
- Power supply section
- Relay function

If any of the board functions are not operating properly, the green LED will not glow.

Electronic Control Board

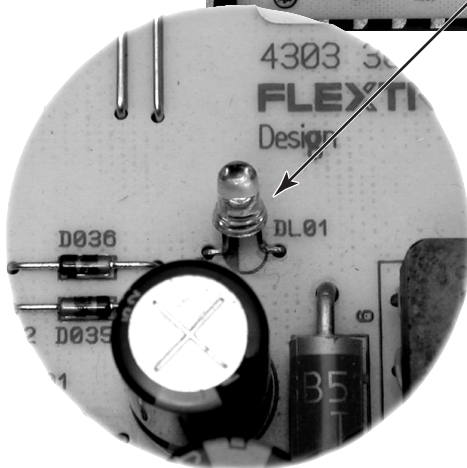
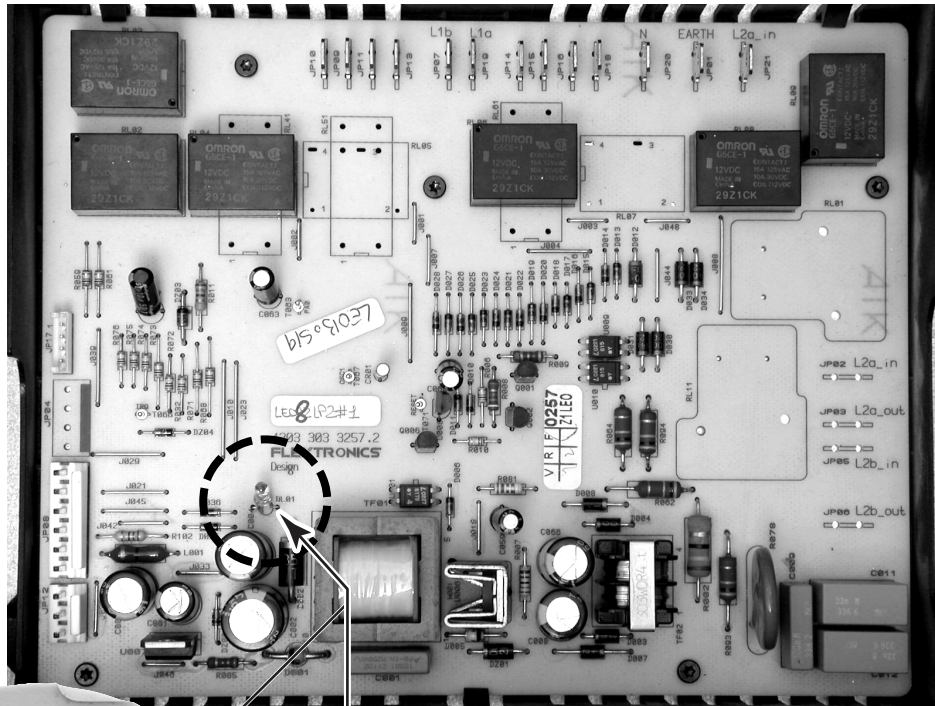

Green "Monitor" LED

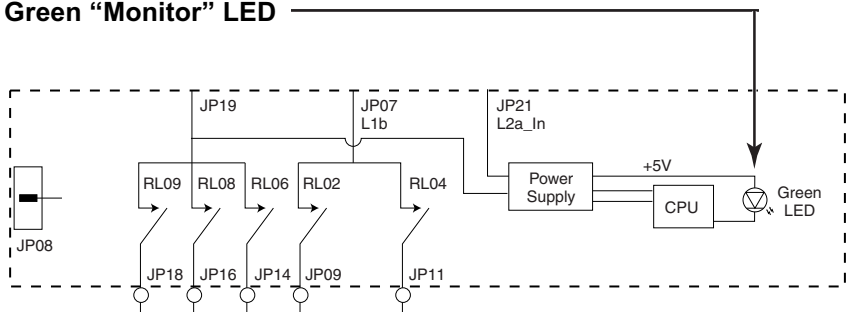

COMPONENT ACCESS

This section instructs you on how to service each component inside the Electronic Touch Ceramic Cooktop. The components and their locations are shown below.

COMPONENT LOCATIONS

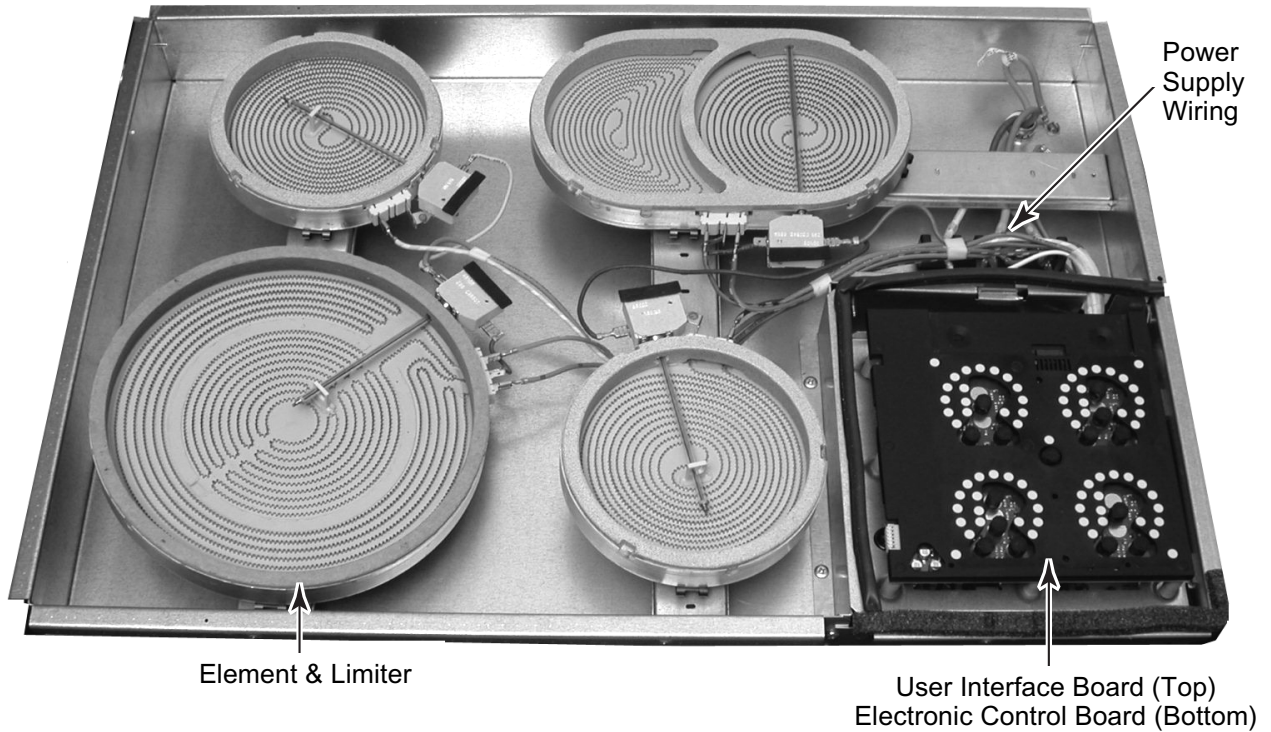

REMOVING THE COOKTOP GLASS

⚠ WARNING



Electrical Shock Hazard

Disconnect power before servicing.

Replace all parts and panels before operating.

Failure to do so can result in death or electrical shock.

1. Disconnect power to the cooktop.
2. Remove the cooktop from its mounting location.
3. Remove the 12 screws (3 on each side) from the front, rear, and side flanges of the cooktop glass.



Cooktop Glass Screws
(6 of 12)

4. Lift the cooktop glass off the burner base.



Lift Off Cooktop Glass

REINSTALLING THE COOKTOP GLASS

NOTE: When you reinstall the cooktop glass on the burner base, make sure that you insert the two alignment pins on the bottom of the glass into the holes of the user interface board assembly for proper alignment.



2 Alignment Pins
On Cooktop Glass

2 Holes In User
Interface Board Assembly

REMOVING AN ELEMENT AND LIMITER

⚠ WARNING



Electrical Shock Hazard
Disconnect power before servicing.
Replace all parts and panels before operating.
Failure to do so can result in death or electrical shock.

1. Disconnect power to the cooktop.
2. Remove the cooktop glass from the burner base (see page 4-2 for the procedure).
3. Disconnect the wires from the terminals of the element and limiter.

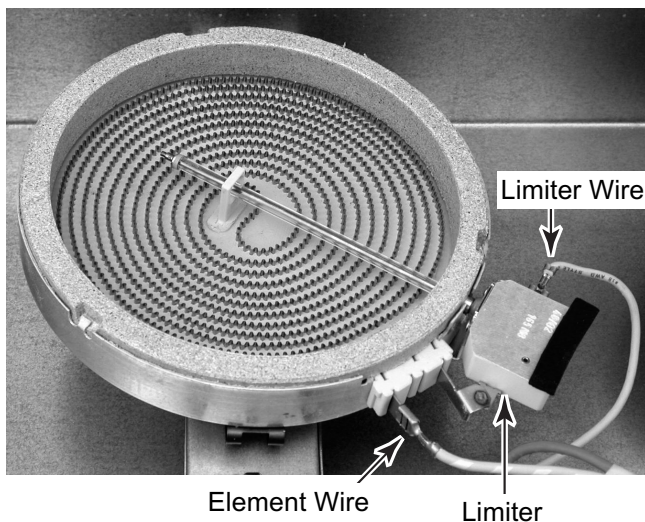

4. Lift the element off the mounting rail. NOTE: You may have to push the tabs on the spring clips under the element out of their mounting rail slots to remove the element. Make sure that you insert the spring clip tabs in their correct mounting rail slots when you reinstall the element.

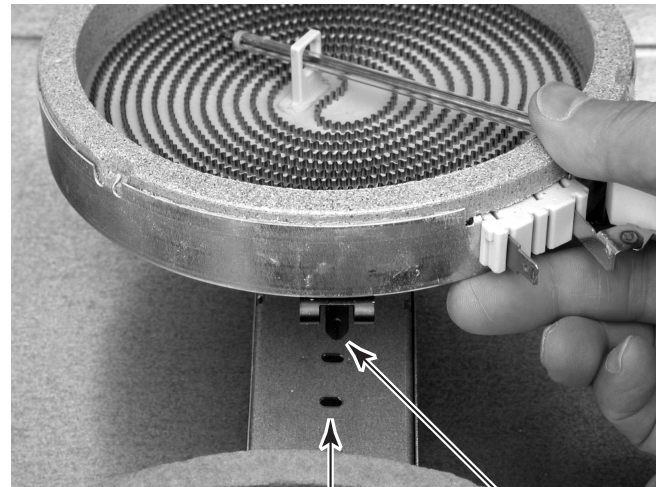

5. Turn the element over and remove the screw from each of the spring clips, then install the clips at the same numbered locations as the old ones.
6. **LF Element Only:** Remove the screw from the limiter and remove the limiter from the element.

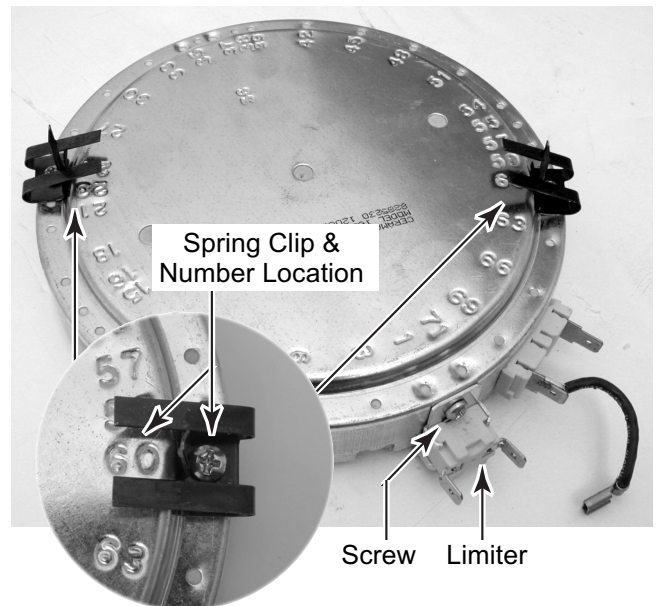

REMOVING THE USER INTERFACE AND ELECTRONIC CONTROL BOARDS

⚠ WARNING



Electrical Shock Hazard

Disconnect power before servicing.

Replace all parts and panels before operating.

Failure to do so can result in death or electrical shock.

1. Disconnect power to the cooktop.
2. Remove the cooktop glass from the burner base (see page 4-2 for the procedure).
3. **To remove the user interface board:**
 - a) Lift the board assembly and rotate it on its left side.

User Interface Board



- b) Pull the edge connector off the left side of the user interface board and remove the board.

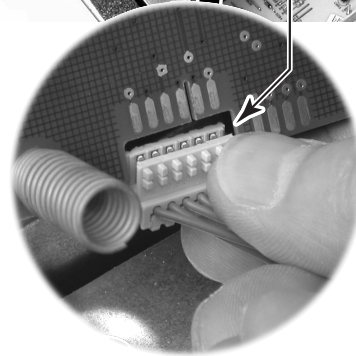
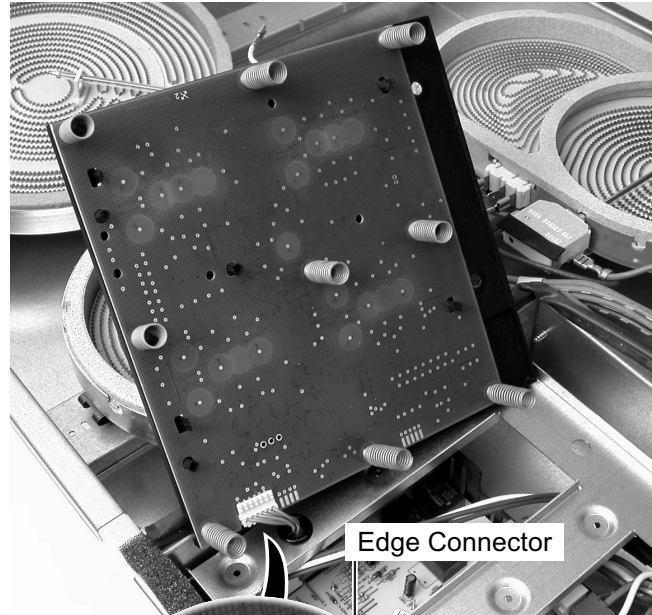

- c) Pull the nine springs off the posts of the plastic light shield.
- d) Unsnap the four latching tabs on the plastic light shield from the board and remove the board from the shield.

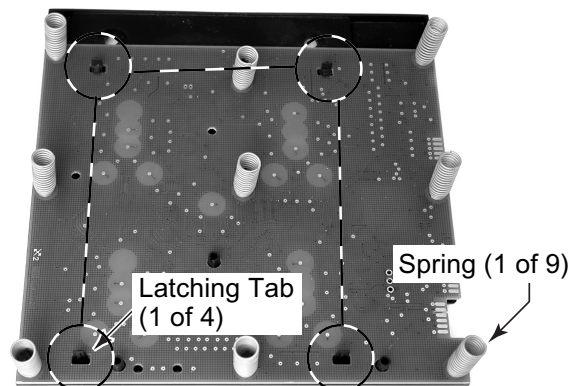

4. **To remove the electronic control board:**

- a) Remove the user interface board (perform step 3).
- b) Lift the right side of the user interface board bracket, and pull the two tabs out of their chassis slots, then pull the right bracket tabs out of their chassis mounting slots.
- c) Rotate the bracket to the left, disconnect wire connector JP08 from the electronic control board, and remove the bracket and wire connector assembly.

User Interface Board Bracket

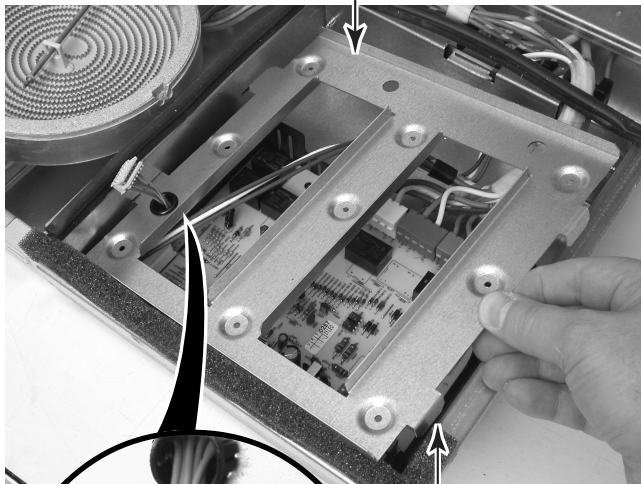

Bracket Tab (1 of 2)

Electronic Control Board Connector JP08

- d) Disconnect the following connectors from the electronic control board (see the photo at the top of the right column):
 - 3-wire connector at JP12.
 - Green connector.
 - White connector.
 - Red connector.
 - Blue connector.

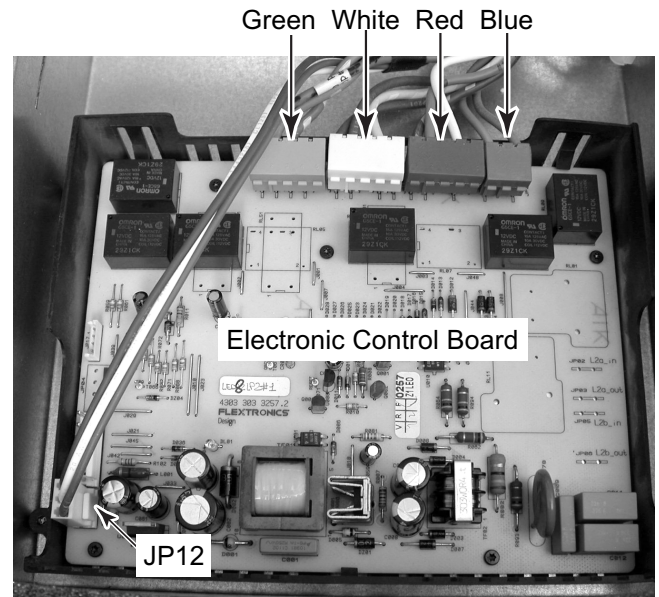

- e) At the bottom of the burner box, remove the four mounting screws from the electronic control board holder.

Electronic Control Board Screws (4)

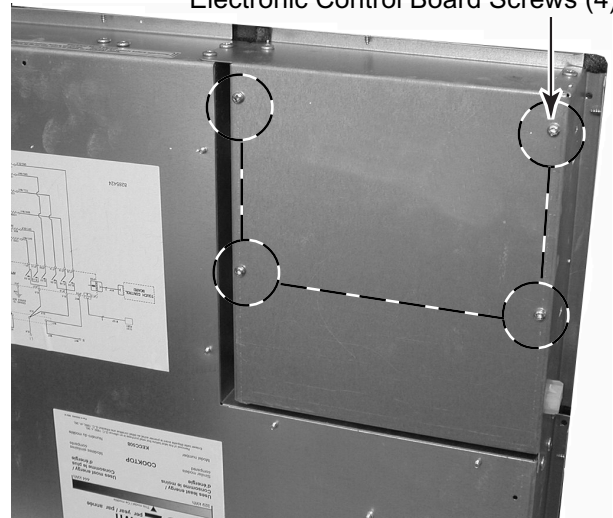

- f) Lift the electronic control board and its holder from the unit.

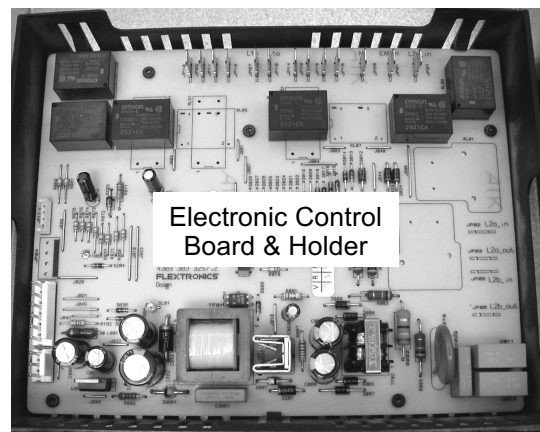

REMOVING THE POWER SUPPLY WIRING

⚠ WARNING



Electrical Shock Hazard

Disconnect power before servicing.

Replace all parts and panels before operating.

Failure to do so can result in death or electrical shock.

1. Disconnect power to the cooktop.
2. Remove the cooktop glass from the burner base (see page 4-2 for the procedure).
3. Remove the hex nuts from the white, red, and black power supply wires and remove the wires from the terminal block studs.
4. Remove the hex-head screw from the green ground wire.

Green (Ground) Power Supply Wire

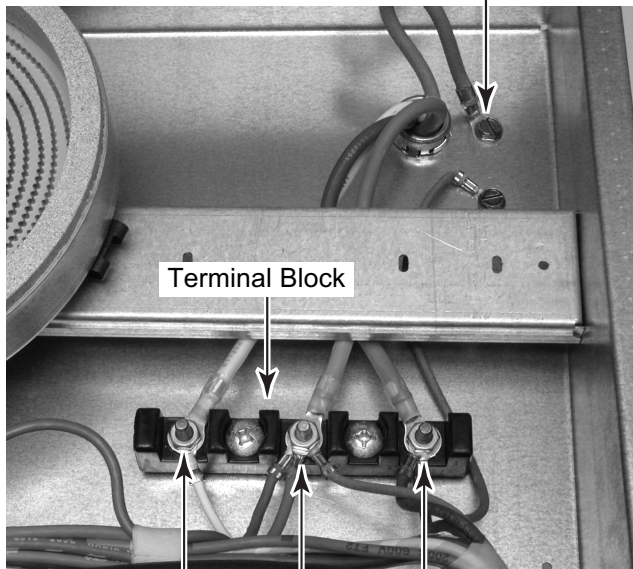

White Red & Black
Power Supply Wires

5. Disconnect the other ends of the black, red, white, and green wires from the house junction box.

6. Remove the two mounting screws from the 90° connector and pull the metal conduit out of the connector and off the wires.

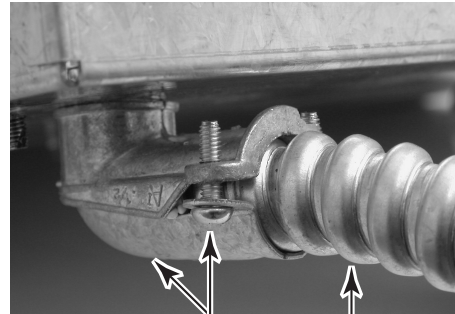

90° Connector & Screw (1 of 2) Conduit

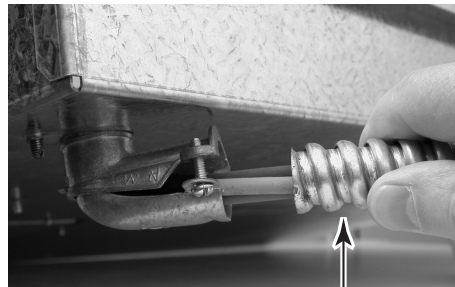

Pull Conduit Off Wires

7. Pull the black, red, white, and green wires out of the connector and burner box.

⚠ WARNING



Electrical Shock Hazard

Connect green ground wire to ground screw.

Failure to do so can result in death or electrical shock.

8. Install the new power supply wires in the conduit and route them into the burner box, then secure the conduit to the connector.
9. Connect the green ground wire to the burner box with its hex-head screw.

COMPONENT TESTING

When testing any of the components, be sure to observe the following conditions:

- Disconnect the power to the cooktop before removing the unit from its mounting location.
- Make sure that all wires are properly connected before operating the cooktop.
- Grasp the wires by their connectors when removing them from the element and limiter terminals.



⚠ WARNING

Electrical Shock Hazard

**Disconnect power before servicing.
Replace all parts and panels before operating.
Failure to do so can result in death or electrical shock.**

LF (DUAL) ELEMENT

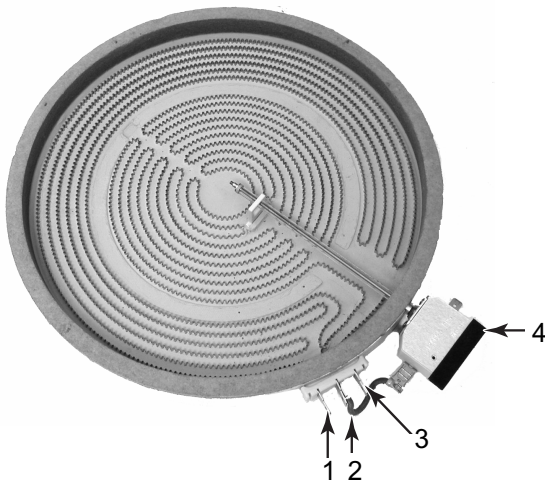

Refer to page 4-3 for the procedure for servicing an element and limiter.

1. Disconnect power to the cooktop.
2. Disconnect the main wiring harness connectors from the element and limiter terminals.
3. Set the ohmmeter to the R x 1 scale.
4. Touch the ohmmeter test leads to the following terminals. The meter should indicate as shown:

Element terminals 1 & 2 = 35 to 46 Ω .

Element terminals 2 & 3 = 52 to 64 Ω .

Limiter terminals 2 & 4 = 0 Ω .

RR (DUAL) ELEMENT

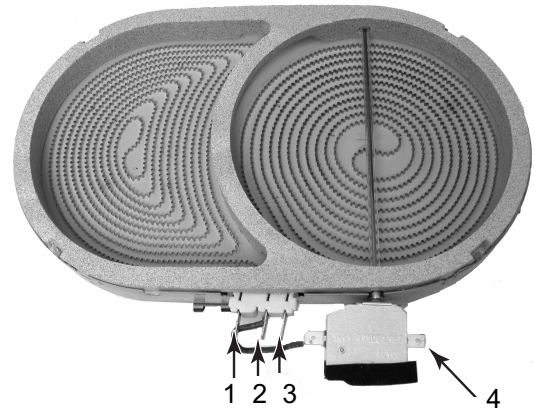

Refer to page 4-3 for the procedure for servicing an element and limiter.

1. Disconnect power to the cooktop.
2. Disconnect the main wiring harness connectors from the element and limiter terminals.
3. Set the ohmmeter to the R x 1 scale.
4. Touch the ohmmeter test leads to the following terminals. The meter should indicate as shown:

Element terminals 1 & 2 = 65 to 80 Ω .

Element terminals 2 & 3 = 50 to 65 Ω .

Limiter terminals 2 & 4 = 0 Ω .



⚠ WARNING

Electrical Shock Hazard

Disconnect power before servicing.

Replace all parts and panels before operating.

Failure to do so can result in death or electrical shock.

RF & LR ELEMENTS

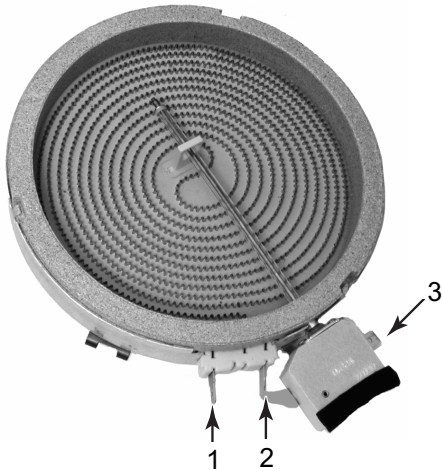

Refer to page 4-3 for the procedure for servicing an element and limiter.

1. Disconnect power to the cooktop.
2. Disconnect the main wiring harness connectors from the element and limiter terminals.
3. Set the ohmmeter to the R x 1 scale.
4. Touch the ohmmeter test leads to the following terminals. The meter should indicate as shown:

Element terminals 1 & 2 = 41 to 56 Ω .

Limiter terminals 2 & 3 = 0 Ω .

DIAGNOSIS & TROUBLESHOOTING

DIAGNOSIS—FAILURE CODES

There are two types of “failure indications” that are displayed by the burner control LEDs:

1. LEDs **2, 4, Med, 8** and **Lo, 3, 5, 7, 9** on the **REAR** burners, (see below), will begin to alternately flash, indicating that the cooktop is in a “failure mode.”

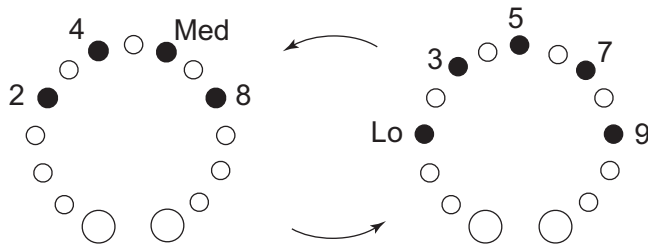

A Cooktop Failure—Rear Burners

2. Specific LEDs on the two **FRONT** burners will light steadily to indicate the “fault code” number. *EXAMPLE:* In the illustration below, the controls indicate a “12” fault code (the left burner has 1 LED lit, and the right burner has 2 LEDs lit).

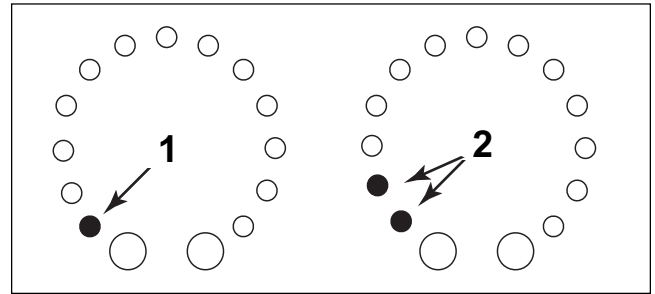

Fault Code—Front Burners

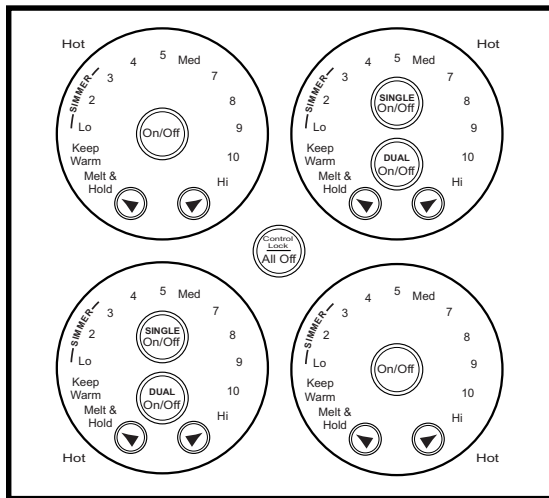



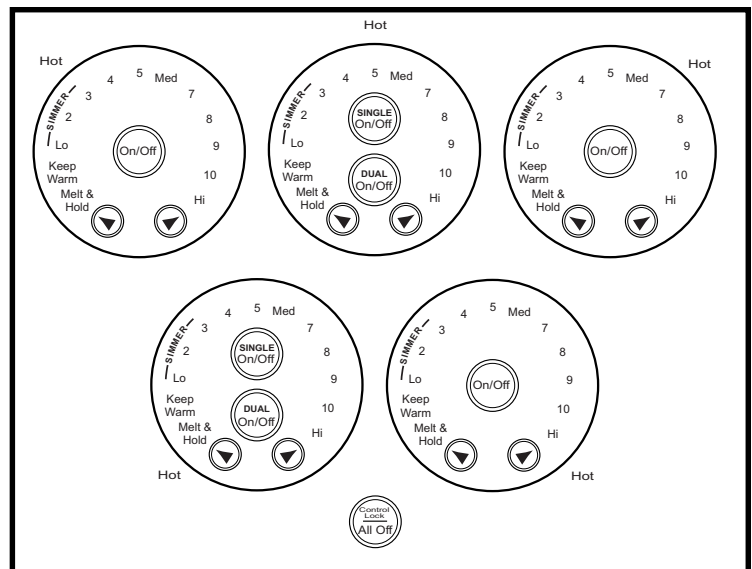





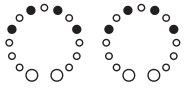

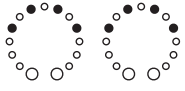
30" Model Burner Controls

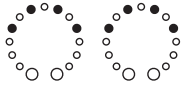





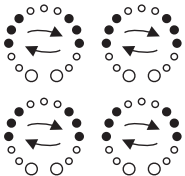



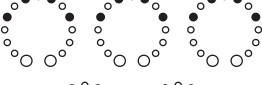

36" Model Burner Controls

Failure Code Chart For 30" Model Cooktops

FAILURE INDICATION		FAULT CODE	CODE EXPLANATION	RECOMMENDED REPAIR PROCEDURE
Cooktop in failure mode (blinking indicators)		F03	One or more keys permanently pressed	<ol style="list-style-type: none"> Clean the glass surface and remove all objects placed on it. If failure remains, disconnect power for 1 minute. Reconnect power. If failure remains, replace the touch control module.
Type of failure (glowing indicators)				
Cooktop in failure mode (blinking indicators)		F12	Electronic board and touch module communication error	<ol style="list-style-type: none"> Disconnect power for 1 minute. Reconnect power. If failure remains, replace board connection cable between touch control module and electronic control. If failure remains, replace the electronic control. If failure remains, replace the touch control module.
Type of failure (glowing indicators)				
Cooktop in failure mode (blinking indicators)		F13	Internal CPU checksum errors	<ol style="list-style-type: none"> Disconnect power for 1 minute. Reconnect power. If failure remains, replace the touch control module.
Type of failure (glowing indicators)				
Cooktop in failure mode (blinking indicators)		F22	Key sensitivity problem	<ol style="list-style-type: none"> Disconnect power for 1 minute. Reconnect power. If failure remains, replace the touch control module.
Type of failure (glowing indicators)				
Cooktop in failure mode (blinking indicators)		F36	Temperature probe hardware error	<ol style="list-style-type: none"> Disconnect power for 1 minute. Reconnect power. If failure remains, replace the touch control module.
Type of failure (glowing indicators)				
OVER TEMPERATURE INDICATION				
Three indicators alternatively blink in left and right side		<p>This is a temporary standby condition to prevent over temperatures in the cooktop. Let the cooktop cool down and the blinking indicators will stop. This description can be found in the Use and Care Guide.</p>		

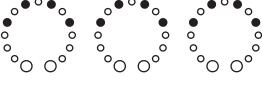
Failure Code Chart For 36" Model Cooktops

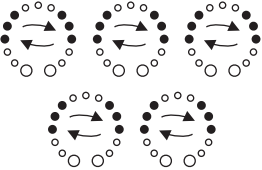
FAILURE INDICATION		FAULT CODE	CODE EXPLANATION	RECOMMENDED REPAIR PROCEDURE
<p>Cooktop in failure mode (blinking indicators)</p>  <p>Type of failure (glowing indicators)</p> 	F03	One or more keys permanently pressed	<ol style="list-style-type: none"> 1. Clean the glass surface and remove all objects placed on it. 2. If failure remains, disconnect power for 1 minute. 3. Reconnect power. 4. If failure remains, replace the touch control module. 	
<p>Cooktop in failure mode (blinking indicators)</p>  <p>Type of failure (glowing indicators)</p> 	F12	Electronic board and touch module communication error	<ol style="list-style-type: none"> 1. Disconnect power for 1 minute. 2. Reconnect power. 3. If failure remains, replace board connection cable between touch control module and electronic control. 4. If failure remains, replace the electronic control. 5. If failure remains, replace the touch control module. 	
<p>Cooktop in failure mode (blinking indicators)</p>  <p>Type of failure (glowing indicators)</p> 	F13	Internal CPU checksum errors	<ol style="list-style-type: none"> 1. Disconnect power for 1 minute. 2. Reconnect power. 3. If failure remains, replace the touch control module. 	
<p>Cooktop in failure mode (blinking indicators)</p>  <p>Type of failure (glowing indicators)</p> 	F22	Key sensitivity problem	<ol style="list-style-type: none"> 1. Disconnect power for 1 minute. 2. Reconnect power. 3. If failure remains, replace the touch control module. 	
<p>Cooktop in failure mode (blinking indicators)</p>  <p>Type of failure (glowing indicators)</p> 	F36	Temperature probe hardware error	<ol style="list-style-type: none"> 1. Disconnect power for 1 minute. 2. Reconnect power. 3. If failure remains, replace the touch control module. 	
OVER TEMPERATURE INDICATION				
<p>Three indicators alternatively blink in left and right side</p> 	<p>This is a temporary standby condition to prevent over temperatures in the cooktop. Let the cooktop cool down and the blinking indicators will stop. This description can be found in the Use and Care Guide.</p>			

TROUBLESHOOTING CHART

PROBLEM	POSSIBLE CAUSE	SOLUTION
Nothing Operates	The power supply cord is unplugged.	Plug into a grounded 3-prong outlet.
	A household fuse has blown or the circuit breaker has tripped.	Replace the fuse or reset the breaker.
Cooktop Will Not Operate	The cooktop control is not set correctly.	Touch ON/OFF before selecting a setting.
	The "Control Lock/All OFF" Cooktop Lockout is not set.	See "All OFF" or "Control Lock" sections in the Use And Care Guide.
Excessive Heat Around Cookware On Cooktop	Cookware is not the proper size.	Use cookware about the same size as the surface cooking area, element, or surface burner. Cookware should not extend more than 1" (2.5 cm) outside the cooking area.
Cooktop Has Flashing Lights	Lights on the cooktop flashing on and off.	<ol style="list-style-type: none"> 1. Make sure the cooktop controls are OFF. 2. Clean the cooktop touch control panel thoroughly. 3. If the cooktop lights continue to flash, disconnect power, or unplug the cooktop. 4. After a few seconds, reconnect power, or plug in the cooktop. 5. Check the two front cooktop LEDs for the Diagnostics Failure Code.
Cooking Results Not As Expected	The proper cookware is not being used.	See "Cookware" section in the Use & Care Guide.
	The cooktop touch control is not set to the proper heat level.	See "Cooktop Touch Controls" section in the Use & Care Guide.
	The appliance is not level.	Level the appliance (see the "Installation Instructions").

WIRING DIAGRAMS & STRIP CIRCUITS

WIRING DIAGRAM—#8285516

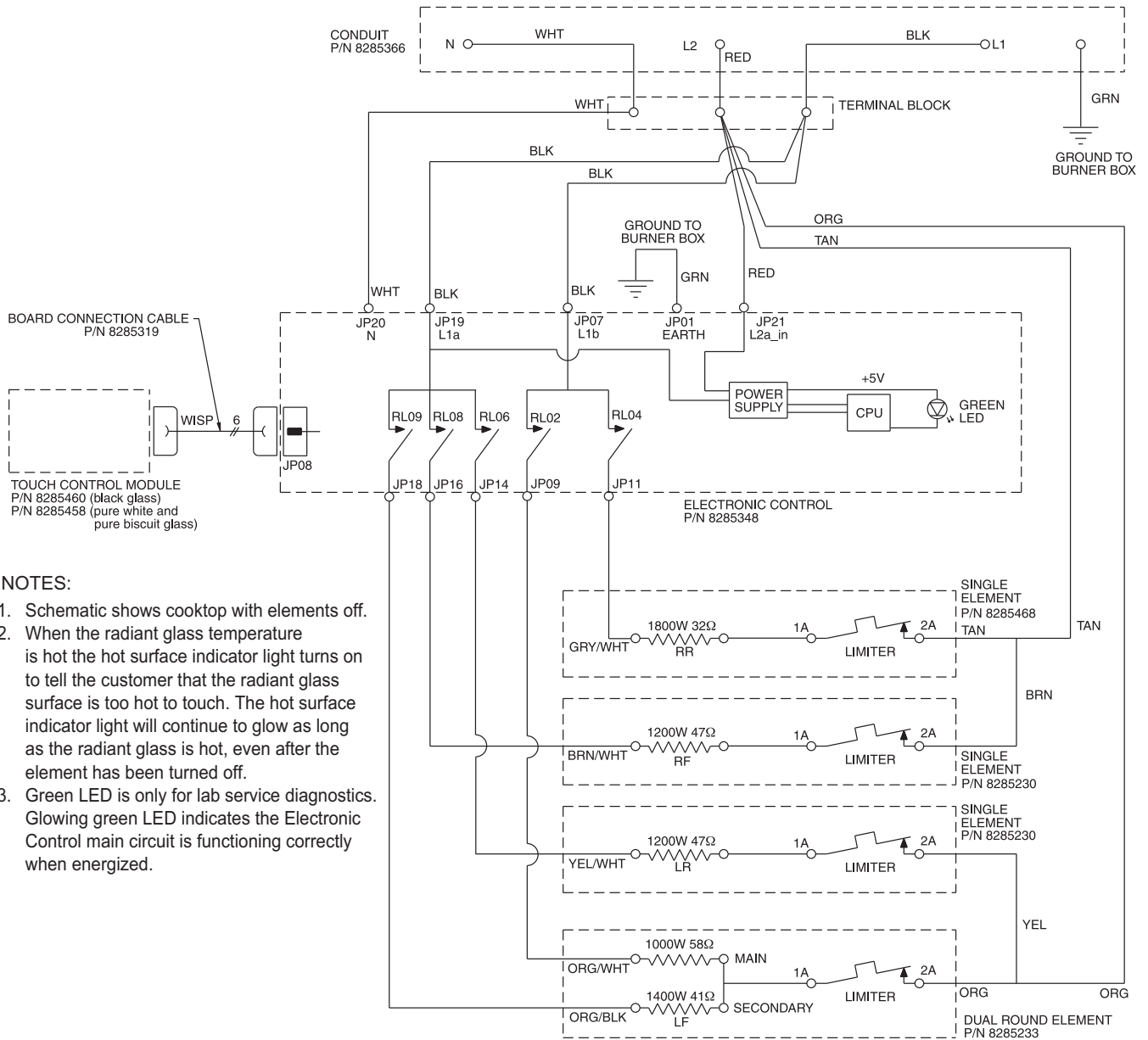

NOTES:

1. Schematic shows cooktop with elements off.
2. When the radiant glass temperature is hot the hot surface indicator light turns on to tell the customer that the radiant glass surface is too hot to touch. The hot surface indicator light will continue to glow as long as the radiant glass is hot, even after the element has been turned off.
3. Green LED is only for lab service diagnostics. Glowing green LED indicates the Electronic Control main circuit is functioning correctly when energized.

STRIP CIRCUITS—#8285516

LEFT REAR ELEMENT

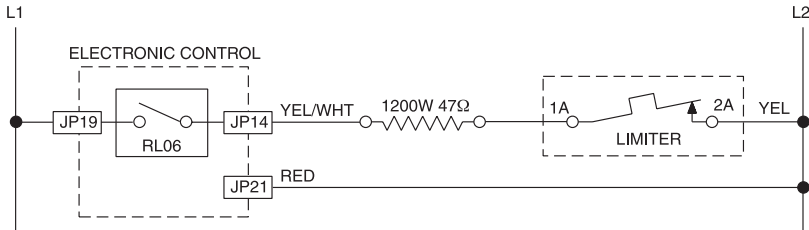

LEFT FRONT ELEMENT

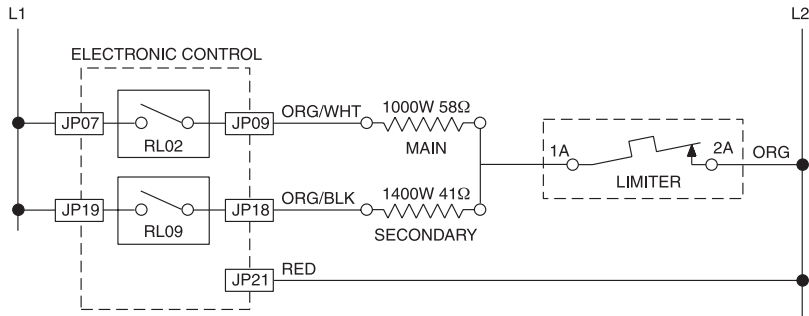

RIGHT REAR ELEMENT

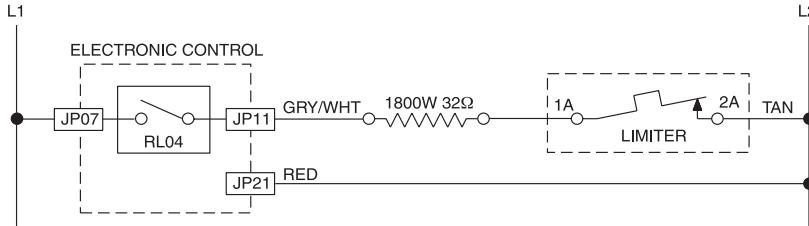

RIGHT FRONT ELEMENT

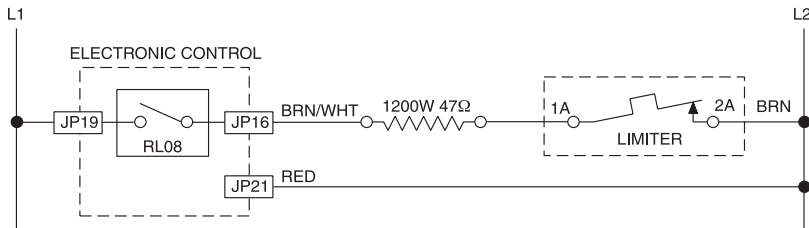

TERMINAL BLOCK CONNECTIONS

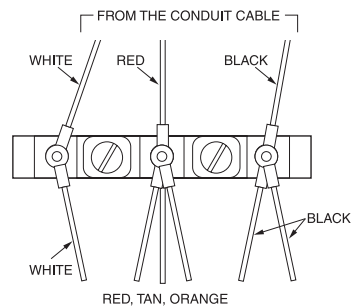

WIRING DIAGRAM—#8285517

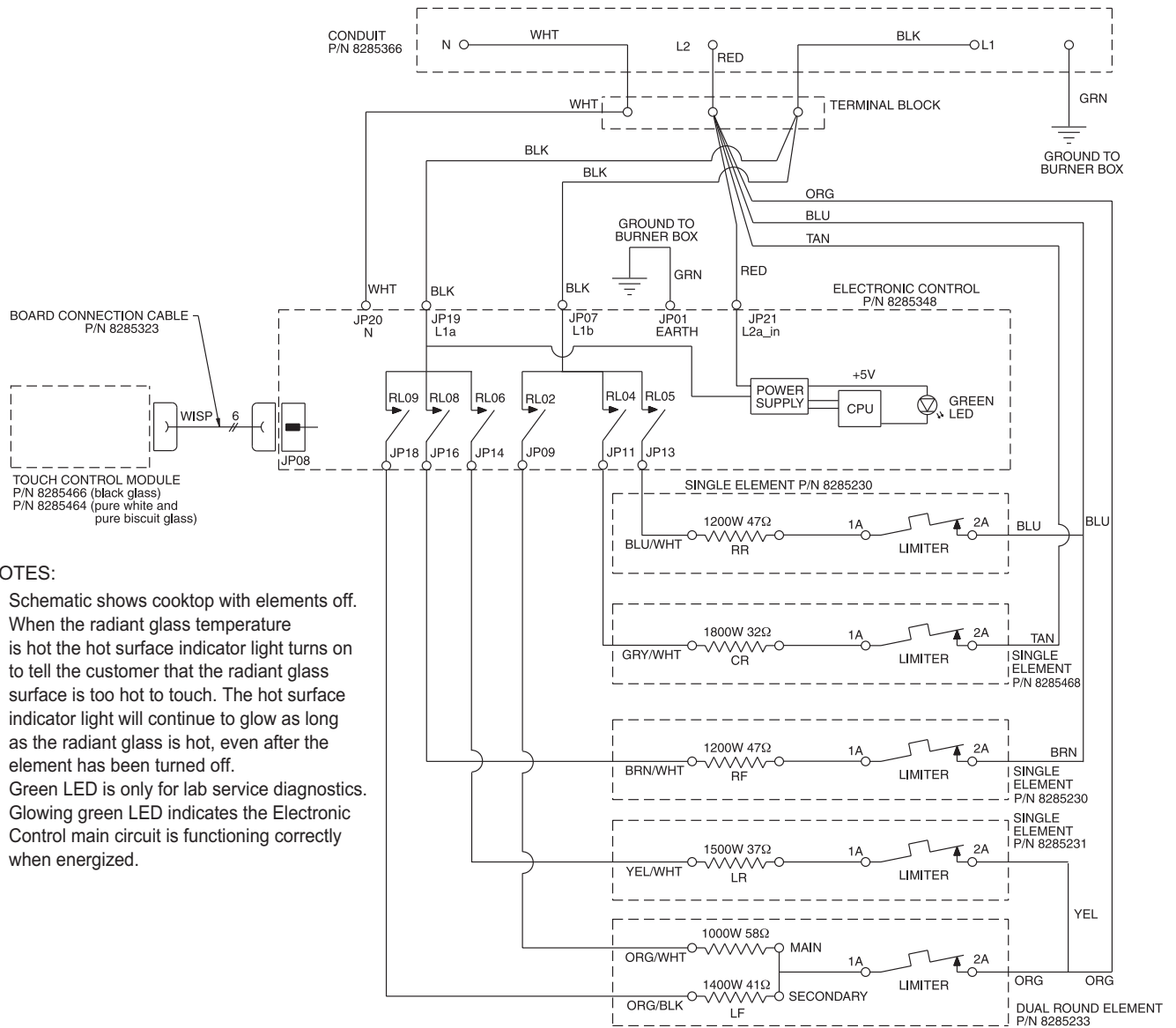

NOTES:

1. Schematic shows cooktop with elements off.
2. When the radiant glass temperature is hot the hot surface indicator light turns on to tell the customer that the radiant glass surface is too hot to touch. The hot surface indicator light will continue to glow as long as the radiant glass is hot, even after the element has been turned off.
3. Green LED is only for lab service diagnostics. Glowing green LED indicates the Electronic Control main circuit is functioning correctly when energized.

STRIP CIRCUITS—#8285517

LEFT REAR ELEMENT

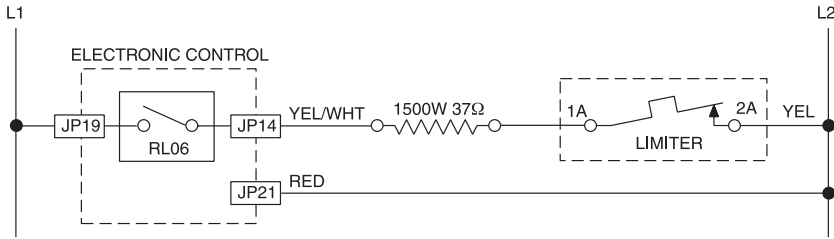

LEFT FRONT ELEMENT

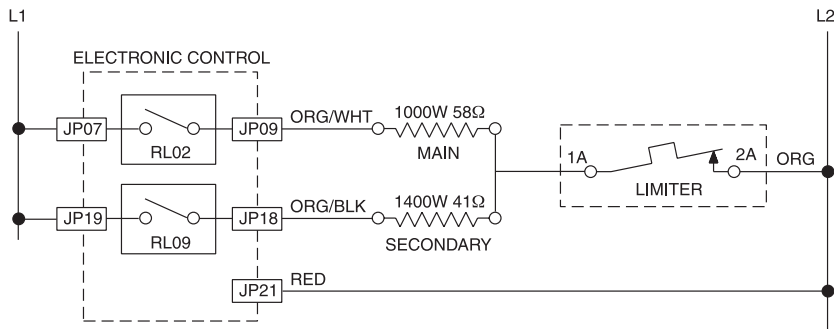

CENTER REAR ELEMENT

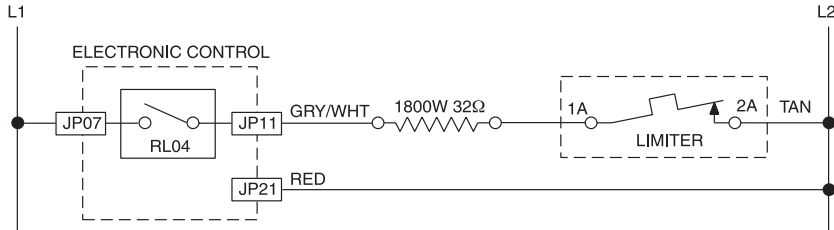

RIGHT REAR ELEMENT

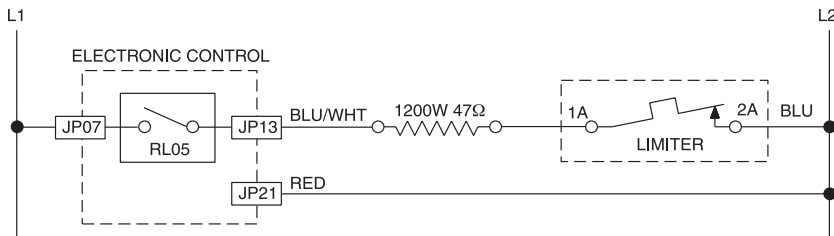

RIGHT FRONT ELEMENT

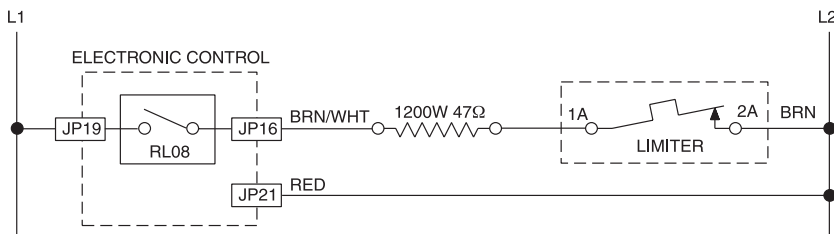

TERMINAL BLOCK CONNECTIONS

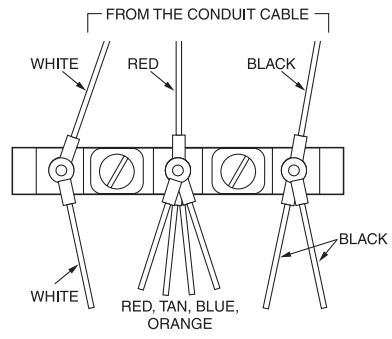

— NOTES —

— NOTES —

— NOTES —

PRODUCT SPECIFICATIONS AND WARRANTY INFORMATION SOURCES

IN THE UNITED STATES:

FOR PRODUCT SPECIFICATIONS AND WARRANTY INFORMATION CALL:

FOR WHIRLPOOL PRODUCTS: 1-800-253-1301
FOR KITCHENAID PRODUCTS: 1-800-422-1230
FOR ROPER PRODUCTS: 1-800-447-6737

FOR TECHNICAL ASSISTANCE WHILE AT THE CUSTOMER'S HOME CALL:

THE TECHNICAL ASSISTANCE LINE: 1-800-253-2870

**HAVE YOUR STORE NUMBER READY TO IDENTIFY YOU AS AN
AUTHORIZED SERVICER**

FOR LITERATURE ORDERS:

PHONE: 1-800-851-4605

FOR TECHNICAL INFORMATION AND SERVICE POINTERS:

www.servicematters.com

IN CANADA:

FOR PRODUCT SPECIFICATIONS AND WARRANTY INFORMATION CALL:

1-800-461-5681

FOR TECHNICAL ASSISTANCE WHILE AT THE CUSTOMER'S HOME CALL:

THE TECHNICAL ASSISTANCE LINE: 1-800-488-4791

**HAVE YOUR STORE NUMBER READY TO IDENTIFY YOU AS AN
AUTHORIZED SERVICER**

KitchenAid[®]
FOR THE WAY IT'S MADE.[®]

