

# **KitchenAid**

TECHNICAL EDUCATION

## **MICROWAVE OVEN / HOOD COMBINATION**



MODEL: KHMS1850S

**JOB AID 4317414**

## FORWARD

This KitchenAid Job Aid, “Microwave Oven / Hood Combination” (Part No. 4317414) provides the In-Home Service Professional with information on the installation, operation, and service of the Microwave Hood Combination. For specific information on the model being serviced, refer to the Use and Care Guide or Tech Sheet provided with the Microwave Oven / Hood Combination.

The Wiring Diagram and Strip Circuits used in this Job Aid are typical and should be used for training purposes only. Always use the Wiring Diagram supplied with the product when servicing the unit.

## GOALS AND OBJECTIVES

The goal of this Job Aid is to provide information that will enable the In-Home Service Professional to properly diagnose malfunctions and repair the KitchenAid Microwave Oven / Hood Combination.

The objectives of this Job Aid are to:

- Understand and follow proper safety precautions.
- Successfully troubleshoot and diagnose malfunctions.
- Successfully perform necessary repairs.
- Successfully return the microwave oven to its proper operational status.

WHIRLPOOL CORPORATION assumes no responsibility for any repairs made on our products by anyone other than authorized In-Home Service Professionals.

# TABLE OF CONTENTS

Page

<b>GENERAL</b> .....	1-1
Microwave Oven Safety .....	1-1
Precautions to Be Observed Before and During Servicing to Avoid Possible Exposure to Excessive Microwave Energy .....	1-2
Model and Serial Number Designations .....	1-3
Model and Serial Number Label and Tech Sheet Locations .....	1-4
Specifications .....	1-5
<b>INSTALLATION INFORMATION</b> .....	2-1
Installation Requirements .....	2-1
Installation Instructions .....	2-3
<b>PRODUCT OPERATION</b> .....	3-1
Parts and Features .....	3-1
Microwave Oven Control .....	3-2
<b>COMPONENT ACCESS</b> .....	4-1
Component Locations .....	4-1
Removing a Hood Lamp Socket and Bottom Cover .....	4-2
Removing the Cabinet .....	4-4
Removing Cavity Thermostat #3 and the Humidity Sensor .....	4-5
Removing the Hood Exhaust Fan Motor .....	4-8
Removing the Cavity Lamp Holder, the Stirrer Motor and Cavity Thermostat #2 .....	4-9
Removing Cavity Thermostat #1, the Motor Capacitor, the AC Line Filter and the Power Supply Cord .....	4-12
Removing the Electronic Control Board and the Touch Control Assembly .....	4-14
Removing the Primary, Secondary and Monitor Interlock Switches .....	4-16
Removing the Line Fuse Holder and the Magnetron Thermostat .....	4-18
Removing the Cooling Fan Motor and the Exhaust Fan Thermostat .....	4-19
Removing High-Voltage Diode and the Power Resistor .....	4-20
Removing the High-Voltage Capacitor and the Magnetron .....	4-21
Removing the High-Voltage Transformer .....	4-24
Removing the Turntable Motor .....	4-25
Removing the Oven Door and Components .....	4-26

	Page
<b>COMPONENT TESTING</b> .....	5-1
Thermostats .....	5-1
Humidity Sensor .....	5-2
Hood Exhaust Fan Motor .....	5-2
Stirrer Motor .....	5-3
Motor Capacitor .....	5-3
AC Line Filter .....	5-4
Door Interlock Switches .....	5-4
Line Fuse .....	5-5
Cooling Fan Motor .....	5-5
High-Voltage Diode .....	5-6
Power Resistor .....	5-6
High-Voltage Capacitor .....	5-7
Magnetron .....	5-7
High-Voltage Transformer .....	5-8
Turntable Motor .....	5-8
<b>DIAGNOSTICS AND TROUBLESHOOTING</b> .....	6-1
Primary, Secondary and Monitor Interlock Switch Checkout Procedure .....	6-1
Failure Code Indications .....	6-2
Touch Panel and Electronic Control Test .....	6-3
Microwave Oven Power Output Test .....	6-4
<b>WIRING DIAGRAM AND STRIP CIRCUITS</b> .....	7-1
Wiring Diagram .....	7-1
Strip Circuits .....	7-2

# GENERAL

## MICROWAVE OVEN SAFETY

### Your safety and the safety of others are very important.

We have provided many important safety messages in this manual and on your appliance. Always read and obey all safety messages.



This is the safety alert symbol.

This symbol alerts you to potential hazards that can kill or hurt you and others.

All safety messages will follow the safety alert symbol and either the word “DANGER” or “WARNING.” These words mean:

 **DANGER**

You can be killed or seriously injured if you don't immediately follow instructions.

 **WARNING**

You can be killed or seriously injured if you don't follow instructions.

All safety messages will tell you what the potential hazard is, tell you how to reduce the chance of injury, and tell you what can happen if the instructions are not followed.

## **PRECAUTIONS TO BE OBSERVED BEFORE AND DURING SERVICING TO AVOID POSSIBLE EXPOSURE TO EXCESSIVE MICROWAVE ENERGY**

- a) Do not operate or allow the oven to be operated with the door open.
- b) Make the following safety checks on all ovens to be serviced before activating the magnetron or other microwave source, and make repairs as necessary:
  - 1. Interlock Operation
  - 2. Proper Door Closing
  - 3. Seal and Sealing Surfaces (Arcing, Wear and Other Damage)
  - 4. Damage to or Loosening of Hinges and Latches
  - 5. Evidence of Dropping or Abuse
- c) Before turning on microwave power for any service test or inspection within the microwave generating compartments, check the magnetron, waveguide or transmission line, and cavity for proper alignment, integrity and connections.
- d) Any defective or misadjusted components in the interlock, monitor, door seal, and microwave generation and transmission systems shall be repaired, replaced, or adjusted by procedures described in service manual before the oven is released to the owner.
- e) A microwave leakage check to verify compliance with the Federal Performance Standard should be performed on each oven prior to release to the owner.
- f) Do not attempt to operate the oven if the door glass is broken.

# MODEL AND SERIAL NUMBER DESIGNATIONS

## MODEL NUMBER

<b>MODEL NUMBER</b>	<b>K</b>	<b>HM</b>	<b>S</b>	<b>18</b>	<b>5</b>	<b>0</b>	<b>S</b>	<b>BL</b>	<b>0</b>
<b>PRODUCT GROUP</b> K = KITCHENAID BRAND									
<b>PRODUCT IDENTIFICATION</b> BH = BUILT-IN HIGH SPEED OVEN BM = BUILT-IN MICROWAVE CM = COUNTERTOP MICROWAVE HM = MICROWAVE HOOD HS = HIGH SPEED									
<b>MERCHANDISING SCHEME</b> S = SENSOR C = MICRO-CONVECTION									
<b>CAPACITY / SIZE / SERIES / CONFIGURATION</b> 05 = 0.5 CU FT    16 = 1.6 CU FT 08 = 0.8 CU FT    17 = 1.7 CU FT 10 = 1.0 CU FT    18 = 1.8 CU FT 13 = 1.3 CU FT    20 = 2.0 CU FT 14 = 1.4 CU FT    22 = 2.2 CU FT 15 = 1.5 CU FT									
<b>FEATURES</b> 2 = PLUS FEATURES 5 = DELUXE FEATURES 6 = MICRO-CONVECTION 7 = MICRO-CONVECTION WITH SENSOR 9 = MULTIMODE - HI SPEED - CONVECTION S = CARRY-IN WARRANTY (EFFECTIVE 02/96) X = IN-HOME WARRANTY (EFFECTIVE 02/96)									
<b>PRODUCT SIZE</b> 0 = 30" WIDE    7 = 27" WIDE 2 = 22" WIDE    8 = 18" WIDE 4 = 24" WIDE    9 = 19" WIDE 6 = 36" WIDE									
<b>YEAR OF INTRODUCTION</b> S = 2007									
<b>COLOR CODE</b> WH = WHITE, BL = BLACK, SS = STAINLESS STEEL									
<b>ENGINEERING CHANGE (0, 1, 2, ETC.)</b>									

## SERIAL NUMBER

<b>SERIAL NUMBER</b>	<b>TR</b>	<b>T</b>	<b>44</b>	<b>10023</b>
<b>MANUFACTURING SITE</b> TR = SHUNDE, CHINA				
<b>YEAR OF PRODUCTION</b> T = 2007				
<b>WEEK OF PRODUCTION</b> 44TH WEEK				
<b>PRODUCT SEQUENCE NUMBER</b>				

# MODEL AND SERIAL NUMBER LABEL AND TECH SHEET LOCATIONS

The Model/Serial Number label and Tech Sheet locations are shown below.



Model/Serial Number Label

**⚠ WARNING**



**Electrical Shock Hazard**  
**Disconnect power before servicing.**  
**Replace all parts and panels before operating.**  
**Failure to do so can result in death or electrical shock.**

Tech Sheet Location

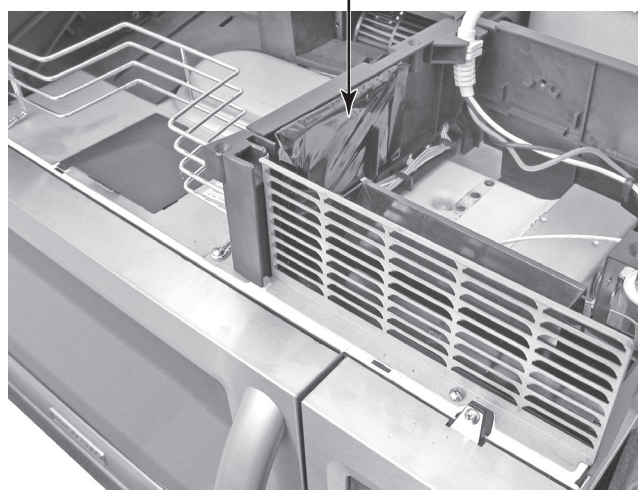



# SPECIFICATIONS

<b>Model</b>	<b>KHMS1850SBL/WH/SS</b>
<b>Control System</b>	
Timer	Electronic
Limits	99 min. 99 sec.
Scale	Linear (Digital)
Operation	Touch Control, Pads TBD
Display	5 + 2 Digit - Blue-Green
Clock	Yes
Independent Minute Timer	Yes
Stage Cooking	Yes (3)
In-Use Reprogramming	Yes
More/Less Function	Yes - Hidden "Cook Power" Button
Keypad Disable/Control Lockout Mode	Yes - Press "OFF/Cancel" Key For 5 Seconds
Cook Power	Yes (10 Levels)
Exhaust Fan	Yes - 1-Key Operation
Number of Speeds	5 (including Off)
Manual Off	Yes
Automatic Turn-On @	140°F/60°C
Cooktop Light	Halogen
Settings	3 Levels (High, Night, Off)
Stoppable Turntable Function / Button	Yes
<b>Oven Interior Features</b>	
Size (Inches)	22 7/8" W x 9 1/2" H x 14 1/2" D
Size (Metric)	581 mm W x 241 mm H x 368 mm D
Capacity	1.8 Cu. Ft.
Finish	Powder Coating
Cooking Power	1000 Watts
Glass Turntable Diameter	12"
<b>Ventilation</b>	Standard Air Flow System
Cooling Fan	Automatic: On if Oven Is Operating; Off If Door Is Open
<b>Door Features</b>	
Side Swing	Left-Hand (Hinge Side)
Seals	Two-Stage
<b>Microwave System</b>	
Distribution	Top Feed w/ Stirrer
Magnetron	Standard Transformer
<b>Safety Features</b>	
Interlock	3 Door/Latch Operated Primary, Secondary and Monitor
Thermal Protectors	5 - 1 Magnetron, 1 Oven Cavity, 1 Hood, 2 Wave Guide

<b>Ventilation System</b>	
Type	Convertible Recirculation or Exhaust Vertical/Horizontal
Recirculation CFM Out	162
Exhaust CFM Out	200
Touch Control	4-Speed
Auto On/High Speed	Yes: 140°F / 60°C
Damper	Yes
Grease Filter	Yes (2)
Charcoal Filter	Yes - Behind Mesh Filter Under Unit
Blower Type	Twin Squirrel Cage
Shipped	Recirculation Mode
<b>Exterior Features</b>	
Outside Dimensions (Inches)	30" x 18" x 17 1/4"
Outside Dimensions (Metric)	762 mm x 457 mm x 438 mm
Power Cord Length	3 Feet
<b>Other Specifications</b>	
Electrical	120 VAC, Single Phase, 60 Hz
	1500 Watts, For Use With 15-20 Amp Circuit
Domestic Use Only	Yes
Agency Approvals	FCC, DHHS, CDRH, UL
Net Weight (Approx.)	73 Lbs.
<b>Literature</b>	
Use & Care Guide	#8206647
Cooking Guide (Label)	#8206649
Installation Instructions	#8206650
Warranty	1 Year Full; 2-5 Year Limited, Magnetron Tube
Tech Sheet	#8206648
Job Aid	#4317414

# INSTALLATION INFORMATION

## INSTALLATION REQUIREMENTS

### INSTALLATION DIMENSIONS

**NOTE:** The grounded 3 prong outlet must be inside the upper cabinet. See "Electrical Requirements," page 2-2.

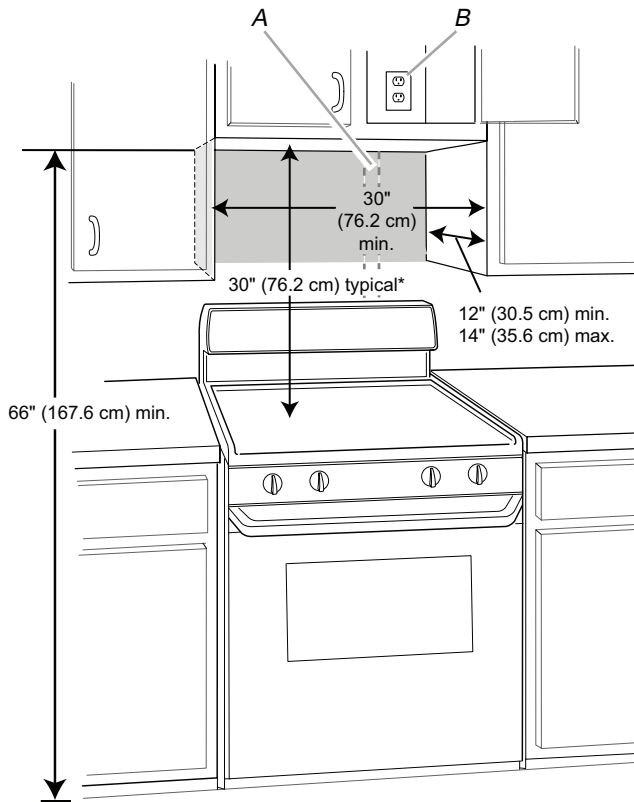

A. 2" x 4" wall stud  
B. Grounded 3 prong outlet

\*30" (76.2 cm) is typical for 66" (167.6 cm) installation height. Exact dimensions may vary depending on type of range/cooktop below.

### PRODUCT DIMENSIONS

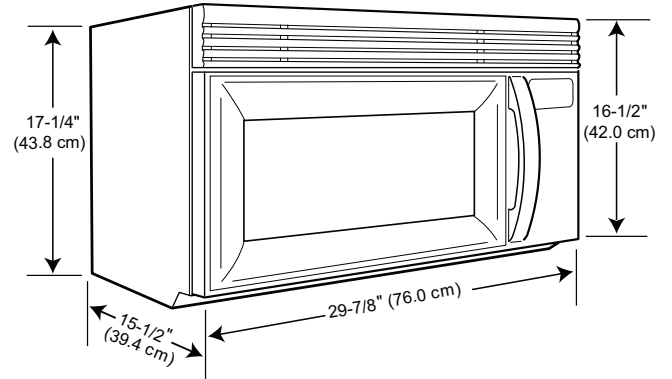

## ELECTRICAL REQUIREMENTS

### **WARNING**



#### **Electrical Shock Hazard**

**Plug into a grounded 3 prong outlet.**

**Do not remove ground prong.**

**Do not use an adapter.**

**Do not use an extension cord.**

**Failure to follow these instructions can result in death, fire, or electrical shock.**

Observe all governing codes and ordinances.

#### **Required:**

- A 120 Volt, 60 Hz, AC only, 15- or 20-amp fused electrical supply (or circuit breaker).

#### **Recommended:**

- A time-delay fuse or circuit breaker is recommended.
- A separate circuit serving only this microwave oven.

## **GROUNDING INSTRUCTIONS**

### • **For all cord connected appliances:**

The microwave oven must be grounded. In the event of an electrical short circuit, grounding reduces the risk of electric shock by providing an escape wire for the electric current. The microwave oven is equipped with a cord having a grounding wire with a grounding plug. The plug must be plugged into an outlet that is properly installed and grounded.

**WARNING:** Improper use of the grounding plug can result in a risk of electric shock. Consult a qualified electrician or serviceman if the grounding instructions are not completely understood, or if doubt exists as to whether the microwave oven is properly grounded.

Do not use an extension cord. If the power supply cord is too short, have a qualified electrician or serviceman install an outlet near the microwave oven.

# INSTALLATION INSTRUCTIONS

## ROTATE BLOWER MOTOR

The microwave oven is set for recirculation installation. For wall or roof venting, changes must be made to the venting system.

**NOTE:** Skip this section if you are using recirculation installation. Keep the damper assembly in case the venting method is changed, or the microwave oven is reinstalled in another location where wall or roof venting may be used.

### Wall Venting Installation Only

1. Remove screw attaching damper plate to top of microwave oven exterior. Slide damper plate back and lift up.

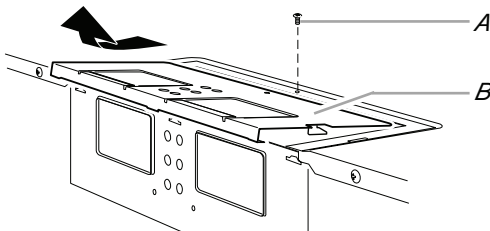

A Screw  
B. Damper plate

2. Keep damper plate and screw together and set aside.
3. Remove two screws attaching blower motor to back of microwave oven.

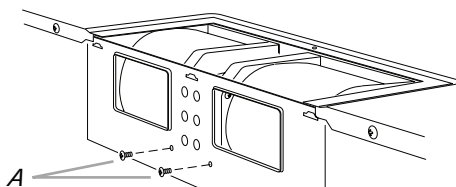

A. Screws

4. Lift blower motor out of microwave oven.

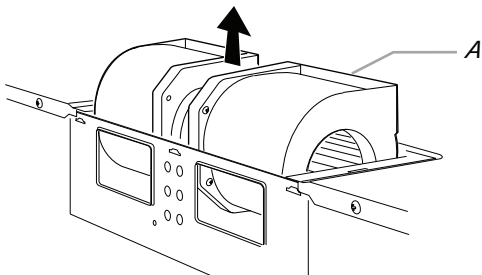

A. Blower motor

5. Rotate blower motor end over end.

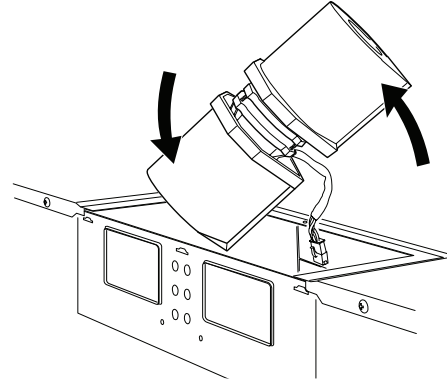

6. Rotate blower motor so that exhaust ports face the back of microwave oven, and lower blower motor back into the microwave oven.

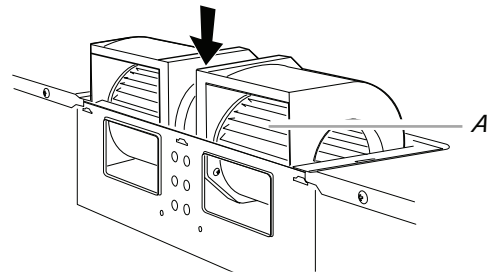

A. Exhaust port

7. Reattach blower motor to back of microwave oven with 2 screws removed in Step 3.
8. Reattach damper plate. Make sure tabs at top and back of damper plate are inserted fully into their respective slots in the microwave oven.

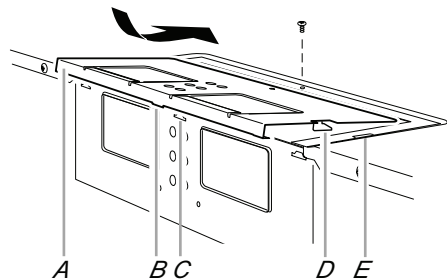

A. Damper plate  
B. Tabs at back of damper plate  
C. Slots in back of microwave oven exterior  
D. Damper plate tabs  
E. Slots in top of microwave oven exterior

9. Secure damper plate with screw.

## Roof Venting Installation Only

1. Repeat Step 1 from “Wall Venting Installation Only on page 13.”
2. Repeat Step 2 from “Wall Venting Installation Only.”
3. Repeat Step 3 from “Wall Venting Installation Only.”
4. Repeat Step 4 from “Wall Venting Installation Only.”
5. Rotate the blower motor so the exhaust ports face the top of the microwave oven and the flat sides of the blower motor face the back of the microwave oven. Lower the blower motor back into the microwave oven.

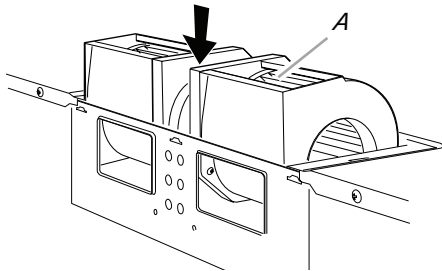

A. Exhaust port

**IMPORTANT:** If blower motor is not positioned with flat sides facing the back of the microwave oven (as shown), performance will be poor.

6. Reattach blower motor to back of microwave oven with 2 screws removed in Step 3 of “Wall Venting Installation Only.” Securely tighten screws.

**NOTE:** If blower motor is not correctly oriented, the 2 screws removed in Step 3 cannot be reattached to the microwave oven.

7. Reattach damper plate. Make sure tabs at top and back of damper plate are inserted fully into their respective slots in the microwave oven.

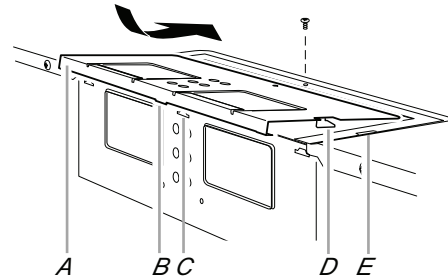

A. Damper plate  
B. Tabs at back of damper plate  
C. Slots in back of microwave oven exterior  
D. Damper plate tabs  
E. Slots in top of microwave oven exterior

8. Secure damper plate with screw.

## INSTALL THE MICROWAVE OVEN

### **! WARNING**

#### **Excessive Weight Hazard**

**Use two or more people to move and install microwave oven.**

**Failure to do so can result in back or other injury.**

**IMPORTANT:** The control side of the microwave oven is the heavy side. Handle the microwave oven gently.

1. Place a washer on each 1/4-20 x 3" bolt and place inside upper cabinet near the 3/8" (10 mm) holes.
2. Make sure the microwave oven door is closed and taped shut.

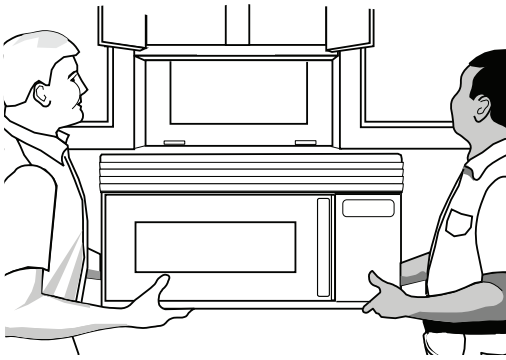

- Using 2 or more people, lift microwave oven and hang it on support tabs at the bottom of mounting plate.

**NOTE:** To avoid damage to the microwave oven, do not grip or use the door or door handle while the microwave oven is being handled.

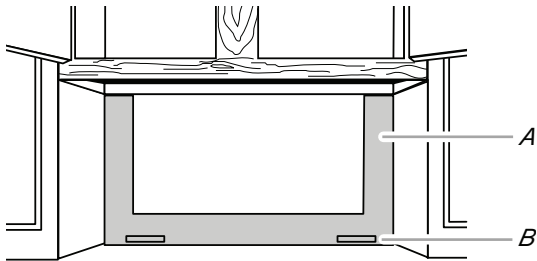

A. Mounting plate  
B. Support tabs

- With front of microwave oven still tilted, thread power supply cord through the power supply cord hole in the bottom of the upper cabinet.

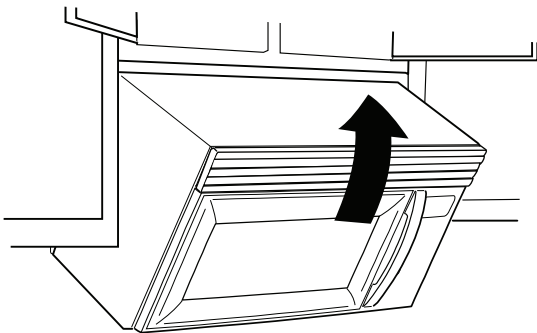

- Rotate the microwave oven up toward upper cabinet.

**NOTE:** If venting through the wall, make sure the damper assembly fits easily into the vent in the wall cutout.

- Push the microwave oven against mounting plate and hold in place.

**NOTE:** If microwave oven does not need to be adjusted, skip steps 7-9.

- If adjustment is required, rotate the microwave oven downward. Using 2 or more people, lift microwave oven off of mounting plate, and set aside on a protected surface.

- Loosen mounting plate screws. Adjust mounting plate and retighten screws.

- Repeat steps 3-6.

- With the microwave oven centered, and with at least one person holding it in place, insert bolts through upper cabinet into microwave oven. Tighten bolts until there is no gap between upper cabinet and microwave oven.

**NOTES:**

- Some upper cabinets may require bolts longer or shorter than 3" (7.6 cm). Longer or shorter bolts are available at most hardware stores.
- Overtightening bolts may warp the top of the microwave oven. To avoid warping, wood filler blocks may be added. The blocks must be the same thickness as the space between the upper cabinet bottom and the microwave oven.

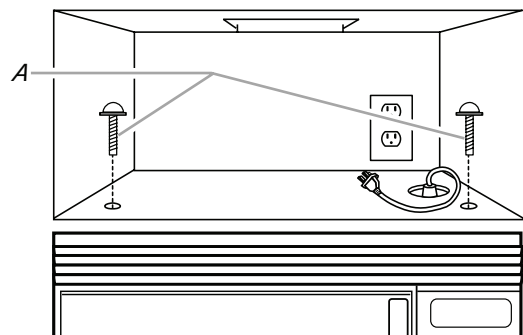

A. Bolts

## For Roof Venting Installation Only

1. Insert damper assembly through the cabinet cutout so that the long tab of the damper assembly slides under the raised tabs of the damper plate. Then secure with sheet metal screw.

**NOTE:** The screw cannot be installed if the damper assembly is not positioned as shown.

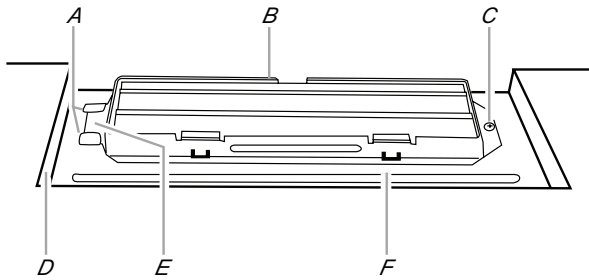

- A. Raised tabs
- B. Damper assembly
- C. Sheet metal screw
- D. Upper cabinet cutout
- E. Long tab
- F. Damper plate

2. Connect vent to damper assembly.

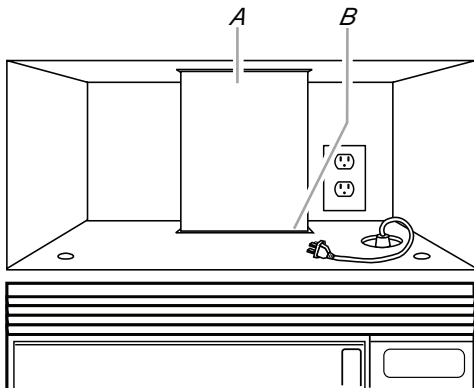

- A. Vent
- B. Damper assembly (under vent)

## ACCESSORIES

Filler Panel Kits are available from your dealer to use when installing this microwave oven in a 36" (91.4 cm) or 42" (106.7 cm) wide opening. The filler panels come in pairs. Each panel is 3" (7.6 cm) wide.

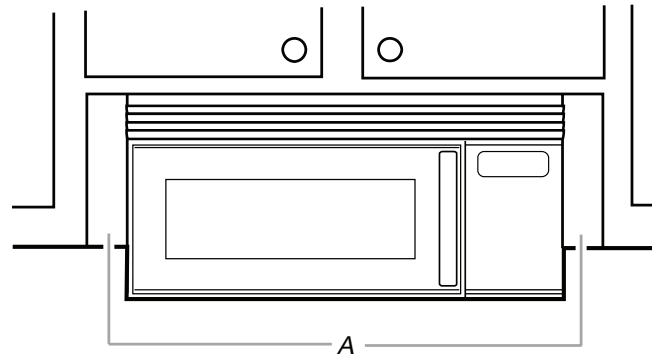

A. Filler panels

Filler Panel Kit Number	8171336	White
	8171337	Black
	8171338	Biscuit
	8171339	Stainless Steel
	99403	Almond

See your authorized dealer or service center for details.



# PRODUCT OPERATION

## PARTS AND FEATURES

This manual may cover several different models. The model you have purchased may have some or all of the features shown here.

The appearance of your particular model may differ slightly from the illustrations in this manual.

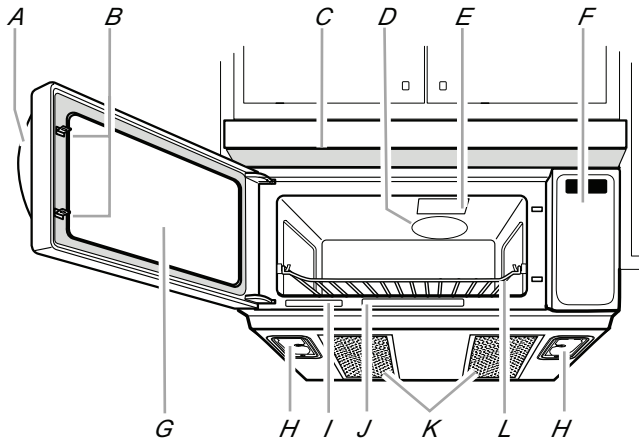

- A. Door handle
- B. Door lock system
- C. Vent grille
- D. Microwave inlet cover
- E. Microwave oven light
- F. Control panel
- G. Metal shielded window
- H. Cooktop lights
- I. Model and serial number plate
- J. Cooking guide label
- K. Charcoal and Grease filters  
(shipped in microwave oven cavity)
- L. Cooking rack

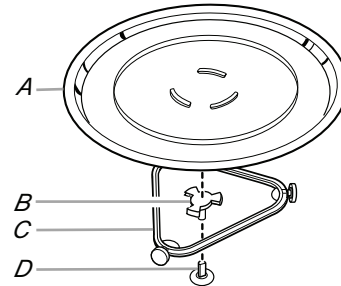

- A. Turntable
- B. Hub
- C. Support
- D. Shaft

## MICROWAVE OVEN CONTROL

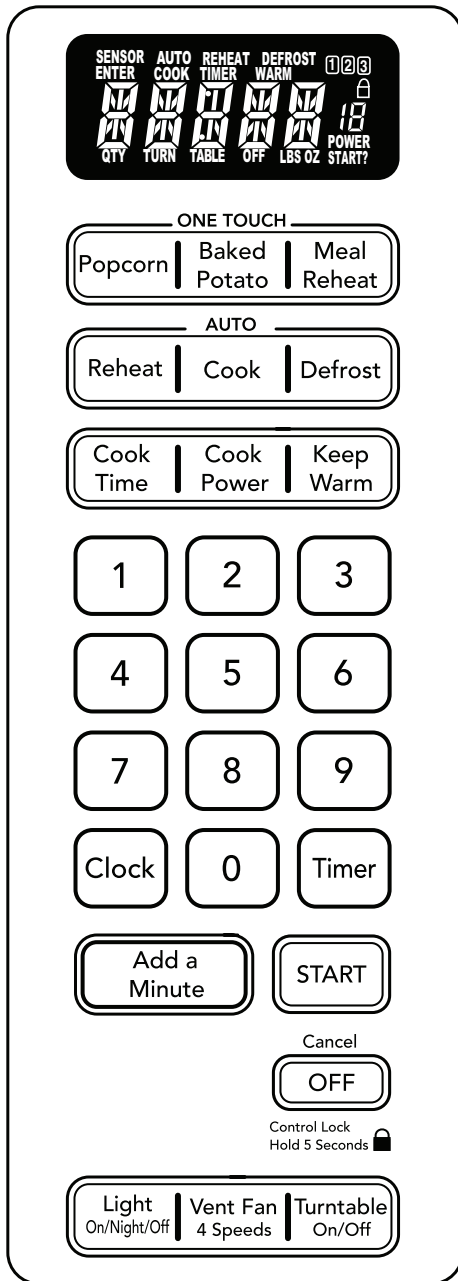

### DISPLAY

When power is first supplied to the microwave oven, a “.” will blink in the display. Touch OFF (Cancel OFF) to stop the blinking. If the “.” blinks in the display at any other time, a power failure has occurred. Touch OFF and reset the clock if needed.

If “RETRY” blinks in the display for 1 second, an invalid value has been entered. Retry your entry.

When the microwave oven is in use, the display shows cooking power, quantities, weights and/or prompts. When the microwave oven is not in use, the display shows the time of day or Timer countdown.

### START

The START control starts any function. If non-sensor cooking is interrupted, touching START will resume the preset cycle.

### Add a Minute

The Add a Minute control automatically starts the microwave oven at 100% power for 1 minute, and adds 1 minute of cook time up to 10 minutes, with each additional touch of the control.

Touching Add a Minute during a cook cycle will add 1 minute of cook time at the current cook power.

### OFF

The OFF control (Cancel OFF) clears any incorrect command and cancels all functions except for the Demo Mode. It will not erase the time of day. The control panel can be locked and unlocked using the OFF control (see “Control Lock” section).

The microwave oven will also turn off when the door is opened. Close the door and touch START to resume the cycle. A sensor cooking cycle may not be resumed if interrupted by opening the door.

### Clock

This is a standard 12-hour clock (12:00-11:59) and does not show a.m. or p.m.

### To Set:

The microwave oven and timer must be off.

1. Touch Clock.
2. Touch the number pads to set the time of day.
3. Touch Clock or START.

### To Remove:

1. Touch Clock.
2. Touch 0.
3. Touch Clock.

The time will disappear, and “:” will appear on the display.

### TONES

Tones are audible signals, indicating the following:

#### One tone

- Valid entry (short tone)
- End-of-Timer countdown (long tone)

#### Two tones

- Reminder, repeating each minute after the end-of-cycle tones
- End of stage in multistage cooking
- Hidden feature has been entered or exited

#### Three tones

- Invalid entry

#### Four tones

- End of cycle

**To Turn Off Valid Entry Tones:** Touch and hold the number pad “1” for 5 seconds until two tones sound. Repeat to turn tones back on.

**To Turn Off All Tones (except End-of-Timer and hidden feature signals):** Touch and hold the number pad “2” for 5 seconds until two tones sound. Repeat to turn tones back on.

### TIMER

The Timer can be set in minutes and seconds, up to 99 minutes 99 seconds, and counts down the set time.

**NOTE:** The Timer does not start or stop the microwave oven.

When the Timer is in use, the microwave oven can also operate. To see the countdown for 5 seconds when the microwave oven is in use, touch Timer.

### To Set:

1. Touch Timer.

If no action is taken after 1 minute, the display will return to the time-of-day mode.

2. Touch the number pads to set the length of time.
3. Touch Timer or START.

If Timer or START is not touched within 5 seconds, “START?” will appear in the display. If Timer or START is not touched within one minute, the display will return to the time-of-day mode and the programmed function will be canceled.

When the set time ends, “END” will appear in the display and one tone will sound.

Touching OFF while a cook function is active in the display will cancel the cook function, not the Timer.

To cancel the Timer, touch TIMER or OFF while the countdown is active in the display.

The length of time can be changed during the countdown by repeating the above steps.

### CONTROL LOCK

The Control Lock shuts down the control panel pads to avoid unintended use of the microwave oven. When the control is locked, only the Vent Fan and Light pads will function.

**To Lock/Unlock Control:** The microwave oven and Timer must be off. Touch and hold OFF for 5 seconds until two tones sound and a lock icon appears in the display. Repeat to unlock and remove the lock icon from display.

### VENT FAN

The vent fan has 4 speeds: high, medium-high, medium and low.

To protect the microwave oven, if the temperature from the range or cooktop below the microwave oven gets too hot, the vent fan will automatically turn on at high speed. It may stay on for up to 1 hour to cool the microwave oven. When this occurs, the vent fan cannot be turned off.

**To Turn Vent Fan On/Off:** Repeatedly touch the Vent Fan 4 Speeds pad to cycle through the four speeds, and then turn the fan off.

### **COOKTOP LIGHT**

The cooktop light has three settings: on, night and off.

**To Turn On/Night/Off:** Touch Light On/Night/Off pad repeatedly to cycle through the settings.

### **DEMO MODE**

The Demo Mode is ideal for learning how to use the microwave oven. When set, functions can be entered without actually turning on the magnetron. The microwave oven light will come on, the fan will run, and if on, the turntable will rotate.

**To Turn On/Off:** The microwave oven and Timer must be off. Touch and hold Timer for 5 seconds until two tones sound and “d” appears in the display. Repeat to turn off and remove “d” from the display.

# COMPONENT ACCESS

This section instructs you on how to service each component inside the Microwave Oven/Hood Combination. The components and their locations are shown below.

## COMPONENT LOCATIONS

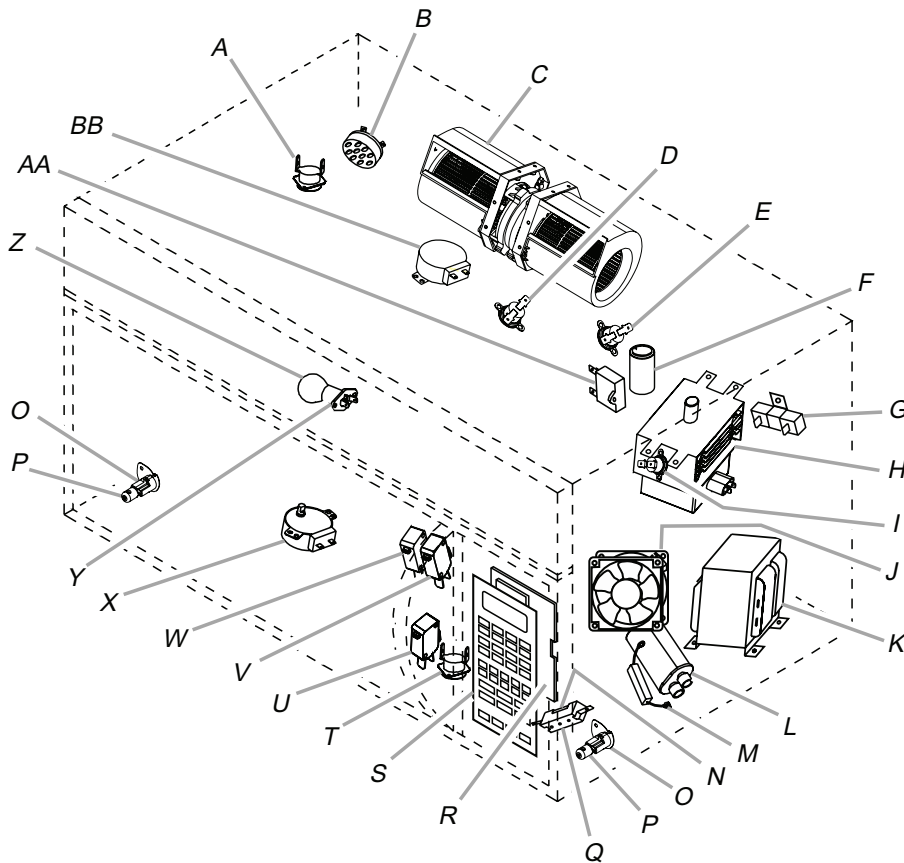

- |   |  |   |
|---|--|---|
| A. Cavity Thermostat #3—opens @ 329°F (165°C), closes at -31°F (-35°C)  | I. Magnetron Thermostat—opens @ 257°F (125°C), closes @ 185°F (85°C) | S. Touch Panel  |
| B. Humidity Sensor  | J. Cooling Fan Motor   | T. Exhaust Fan Thermostat—opens @ 113°F (45°C), closes @ 140°F (60°C) |
| C. Hood Exhaust Fan Motor   | K. H.V. Transformer  | U. Secondary Interlock Switch   |
| D. Cavity Thermostat #2—opens at 257°F (125°C), closes at -31°F (-35°C) | L. H.V. Capacitor  | V. Monitor Interlock Switch   |
| E. Cavity Thermostat #1—opens @ 257°F (125°C), closes @ -31°F (-35°C)   | M. H.V. Diode  | W. Primary Interlock Switch   |
| F. AC Line Filter   | N. Line Fuse (20 amp)  | X. Turntable Motor  |
| G. Power Resistor   | O. Hood (cooktop) Lamp Holders                                       | Y. Cavity Lamp Holder   |
| H. Magnetron  | P. Hood (cooktop) Lamps  | Z. Cavity Lamp  |
|   | Q. Fuse Holder   | AA. Motor Capacitor   |
|   | R. Electronic Control  | BB. Stirrer Motor   |

# REMOVING A HOOD LAMP SOCKET AND BOTTOM COVER

## ⚠ WARNING



### Electrical Shock Hazard

Disconnect power before servicing.  
Replace all parts and panels before operating.

Failure to do so can result in death or electrical shock.

1. Unplug microwave oven or disconnect power.
2. Remove the ten screws from the bottom cover and lower the cover.



Screw (1 of 10) Bottom Cover Assembly

### 3. To remove a hood lamp socket:

- a) Remove the screw from the lamp socket mounting plate and remove the plate from the holder (see the top right photos).

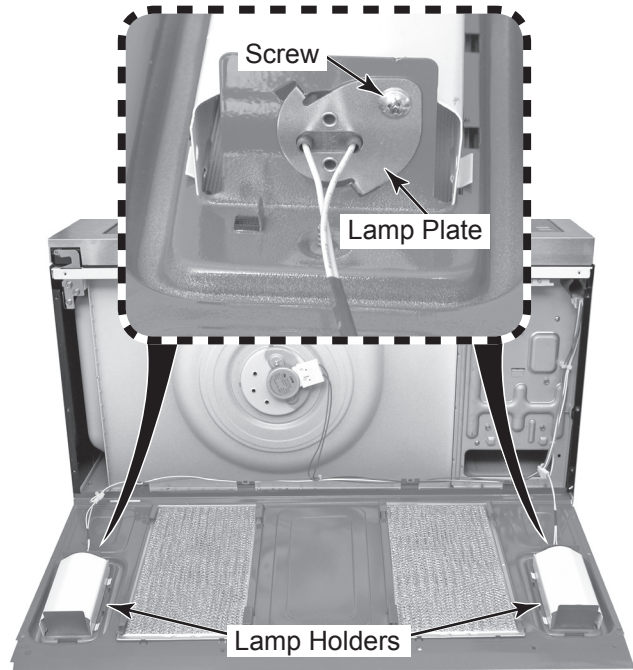

- b) Pull the bulb from the lamp socket.
- c) Cut the lamp socket wires near the socket, and splice a new socket and mounting plate in its place.

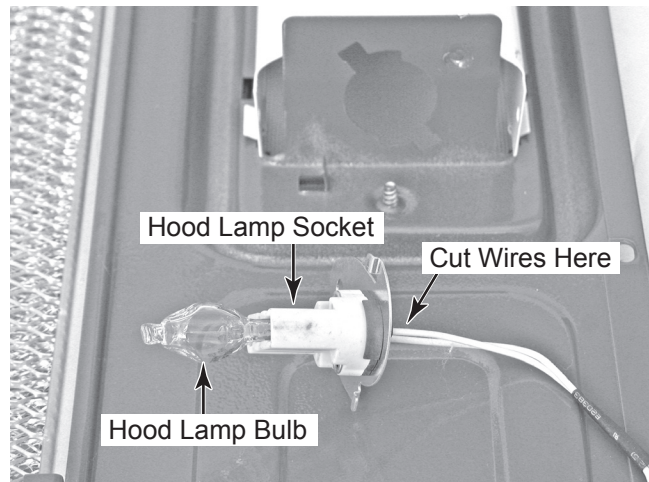

4. **To remove the bottom cover:**
- a) Disconnect the wire connector from the turntable motor terminals.
  - b) Unlatch and disconnect the 6-hole power connector from the microwave oven and unclip the wires from the standoff.
  - c) Unhook the bottom cover assembly from the microwave oven and remove

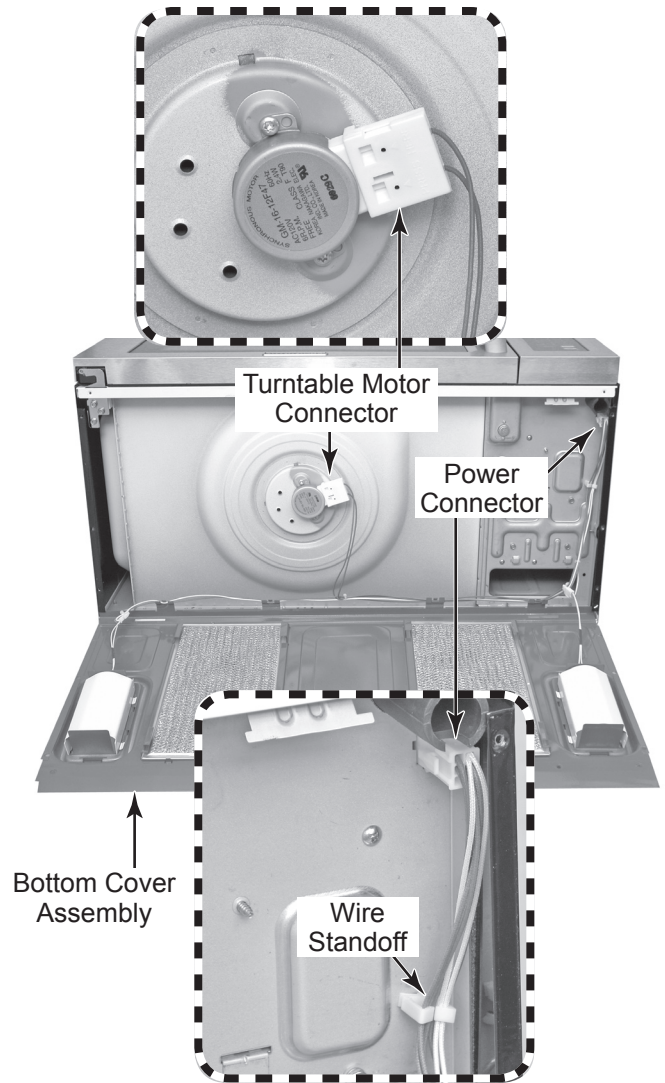

# REMOVING THE CABINET

## ⚠ WARNING



### Electrical Shock Hazard

Disconnect power before servicing.

Replace all parts and panels before operating.

Failure to do so can result in death or electrical shock.

1. Unplug microwave oven or disconnect power.
2. Remove the microwave oven from its mounting location (see page 2-4 for the procedure and do reverse procedure).
3. Remove the two screws from the front air vent, pull forward, and remove the vent from the oven.

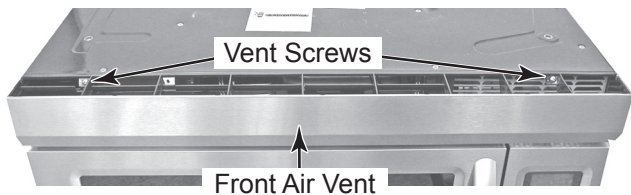

4. Remove the screw from the top vent cover. Push the vent towards the back, unhook it, and remove the vent from the top of the cabinet.

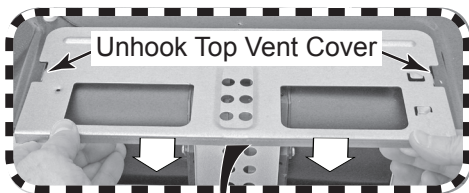

5. Remove the five flat-head screws from the top of the cabinet.

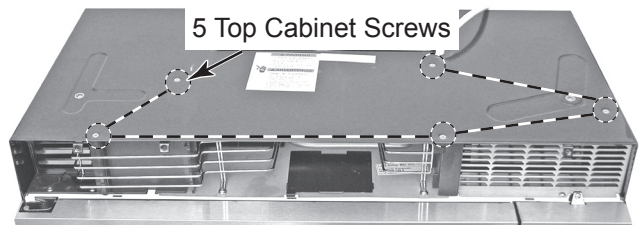

6. Remove the following screws from the cabinet:

- a) One right side screw.
- b) Eight rear screws.
- c) Six bottom side screws.

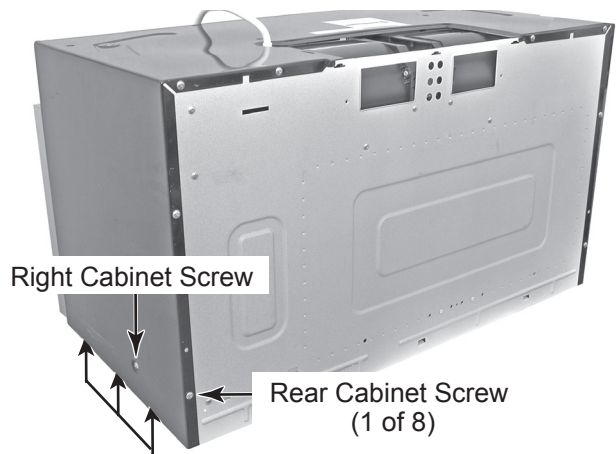

3 Bottom Cabinet Screws (each side)

7. Pull the cabinet back so that the tabs on the front sides disengage from the front panel, and remove the cabinet from the oven.





## REMOVING CAVITY THERMOSTAT #3 AND THE HUMIDITY SENSOR

### **⚠ WARNING**



**Electrical Shock Hazard**  
**Disconnect power before servicing.**  
**Replace all parts and panels before operating.**  
**Failure to do so can result in death or electrical shock.**

1. Unplug microwave oven or disconnect power.
2. Remove the microwave oven from its mounting location (see page 2-4 for the procedure and do procedure in reverse).
3. Remove the cabinet from the oven (see page 4-4 for the procedure).

Cavity Thermostat #3 and Humidity Sensor

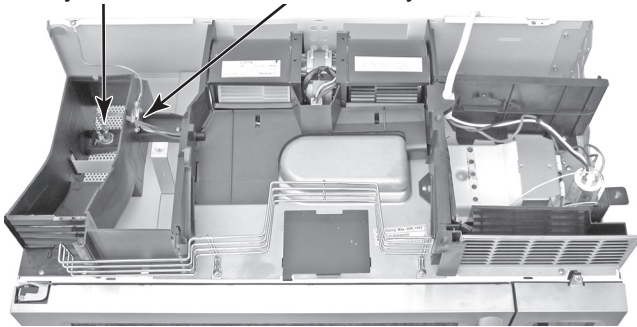

4. **To remove cavity thermostat #3:**
  - a) Disconnect the wires from the thermostat terminals (see the top-right photo).
  - b) Press down on the two holder locking tabs, rotate the thermostat counter-clockwise until it is free of the catches, and remove the thermostat.

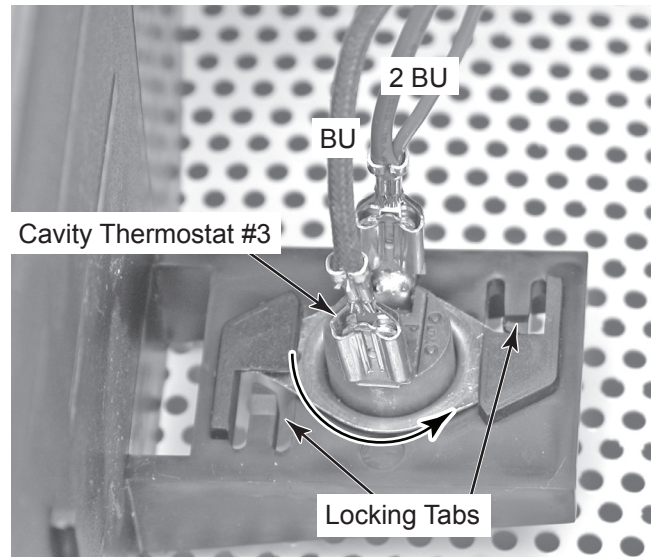

5. **To remove the humidity sensor:**
  - a) Remove the four screws from the cavity thermostat and humidity sensor holder.

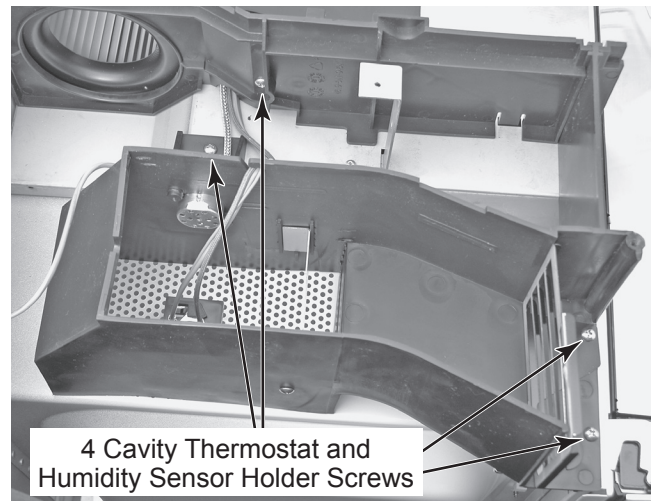

**Continued on the next page.**

- b) Unhook and lift the locking arm on the cavity thermostat and humidity sensor holder from the slot in the oven.
- c) Unhook the cavity thermostat and humidity sensor holder from the left side of the top cover, and move the holder to the left.

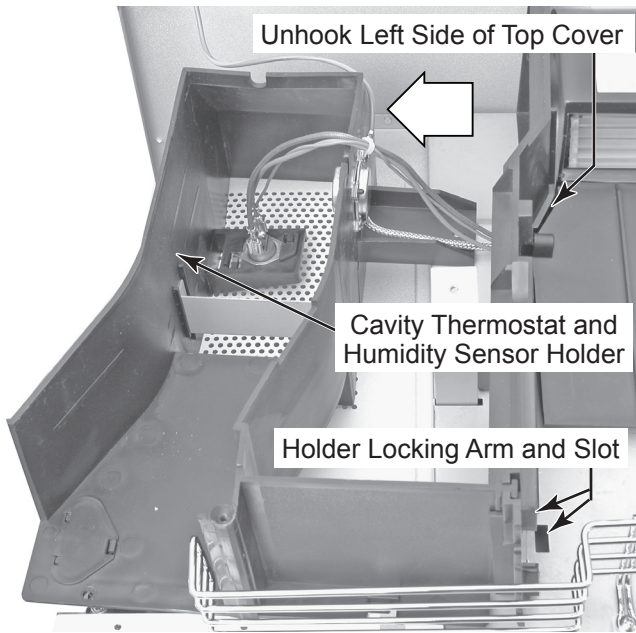

- d) Remove the top screw from the control panel. Open the oven door, lift the panel, unhook the side latching tabs from the slots, and tilt the panel forward.



- e) Disconnect the 3-wire humidity sensor cable (red, white and black) from humidity sensor connector P1.

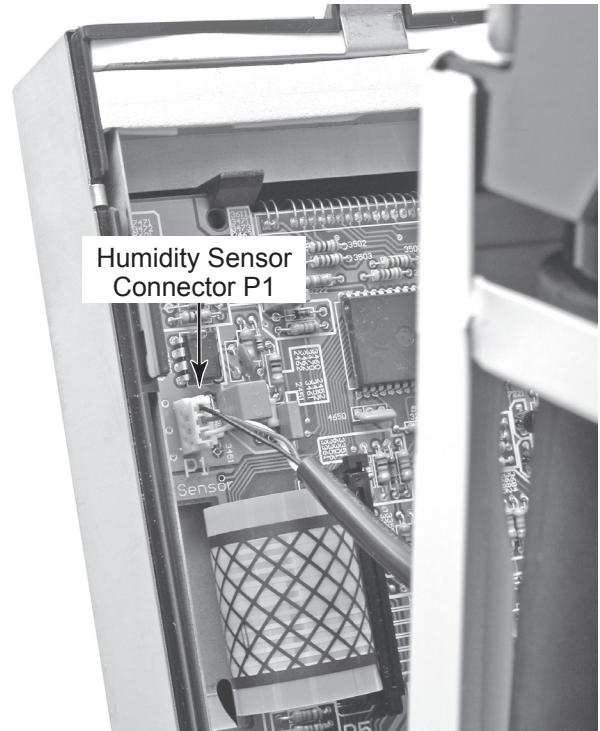

- f) Remove the humidity sensor cable from the clips in the bottom of the top cover and along the right front air guide.

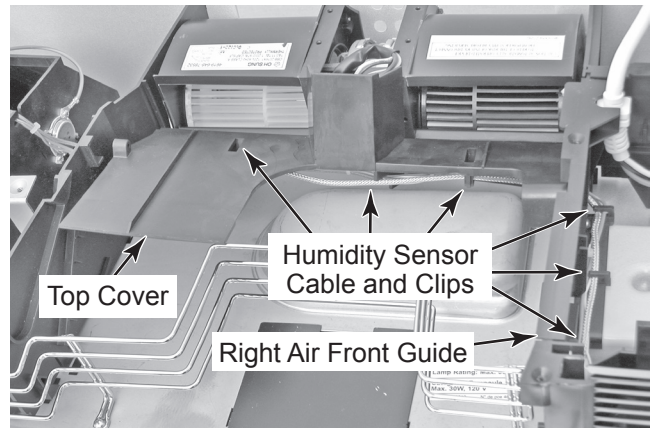

- g) Remove the two screws and the end of the green ground wire from the humidity sensor.
- h) Pull the end of the humidity sensor cable from under the top cover.

**REASSEMBLY NOTE:** When you reinstall the humidity sensor, make sure that you position the sensor cable facing down and the green ground wire at the indicated screw.

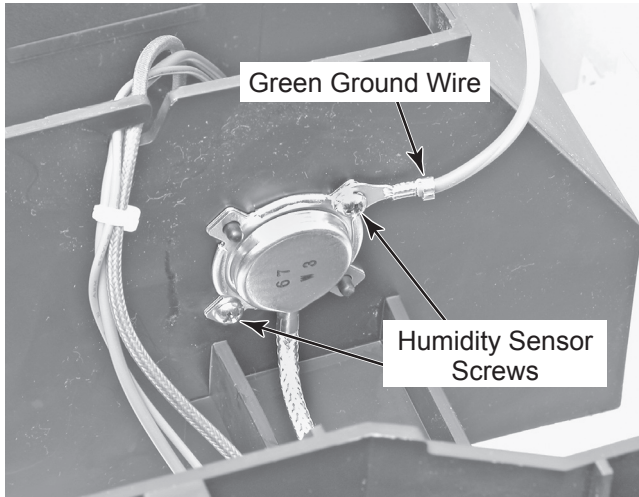

# REMOVING THE HOOD EXHAUST FAN MOTOR

## **⚠ WARNING**



### **Electrical Shock Hazard**

**Disconnect power before servicing.**

**Replace all parts and panels before operating.**

**Failure to do so can result in death or electrical shock.**

1. Unplug microwave oven or disconnect power.
2. Remove the microwave oven from its mounting location (see page 2-4 for the procedure and do procedure in reverse).
3. Remove the cabinet from the oven (see page 4-4 for the procedure).

Hood Exhaust Fan Motor

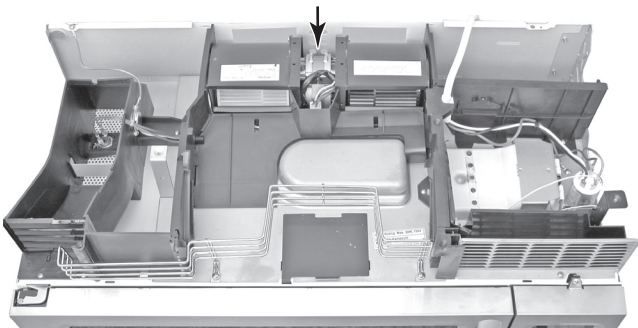

4. Remove the two hood exhaust fan motor screws from the rear panel.
5. Unlatch and disconnect the hood exhaust fan motor wire connector from the oven.

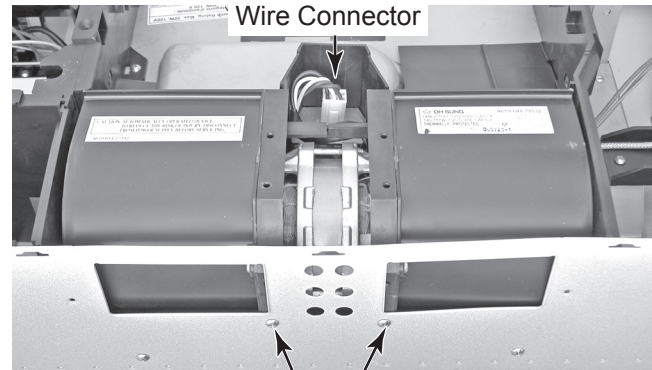

Hood Exhaust Fan Motor Screws

6. Lift the hood exhaust fan motor out of the oven and remove it.

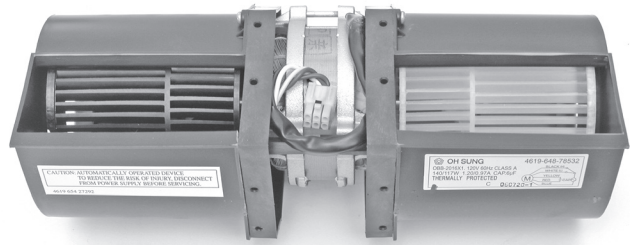

# REMOVING THE CAVITY LAMP HOLDER, THE STIRRER MOTOR, AND CAVITY THERMOSTAT #2

## ⚠ WARNING



### Electrical Shock Hazard

**Disconnect power before servicing.  
Replace all parts and panels before  
operating.**

**Failure to do so can result in death or  
electrical shock.**

1. Unplug microwave oven or disconnect power.
2. Remove the microwave oven from its mounting location (see page 2-4 for the procedure and do procedure in reverse).
3. Remove the cabinet from the oven (see page 4-4 for the procedure).

Stirrer Motor    Cavity Therm. #2    Cavity Lamp Holder

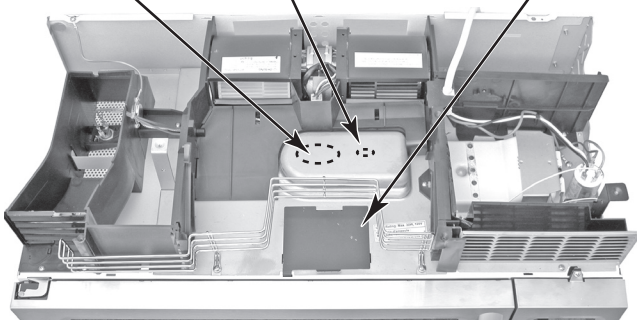

4. Remove the hood exhaust fan motor (see page 4-8 for the procedure).
5. Remove the two top subpanel screws from the rear panel (see the top-right photo).

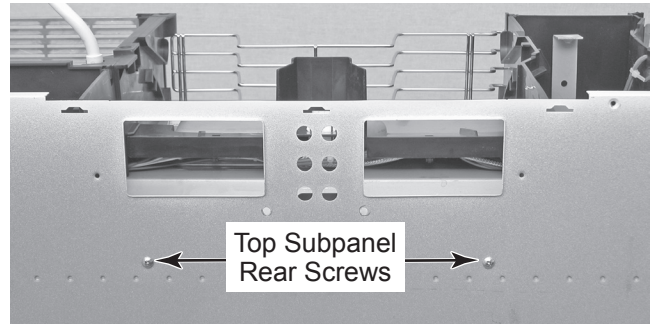

6. Lift the right-rear air guide and unhook it from the right-front air guide.
7. Pull the power supply cord off the right-front air guide.
8. Remove the five indicated screws from the top subpanel. Remove the left air grille and the wire grille from the oven after the screws are removed.

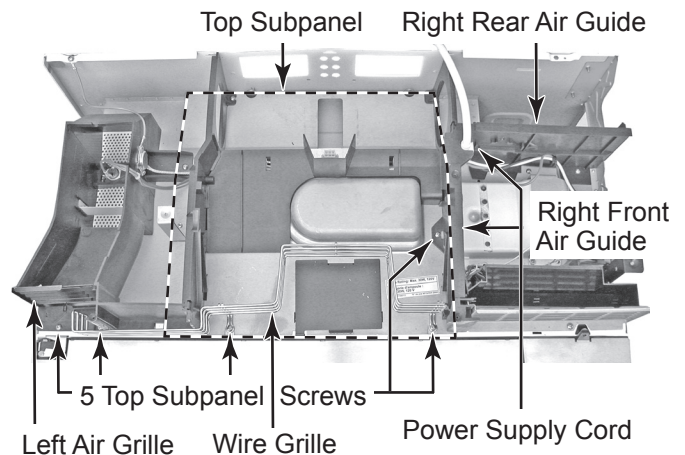

**Continued on the next page.**

9. Lift the rear of the top subpanel assembly, pull it back slightly, raise the front, and remove the wires from the three indicated clips.

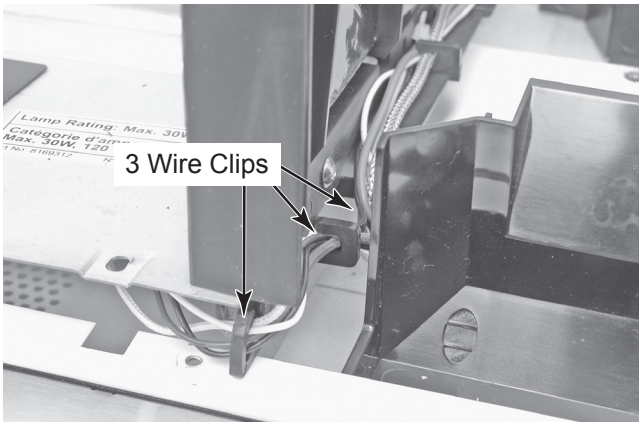

10. Prop the top assembly up so that you can access the stirrer motor, cavity thermostat #2, and cavity lamp holder.

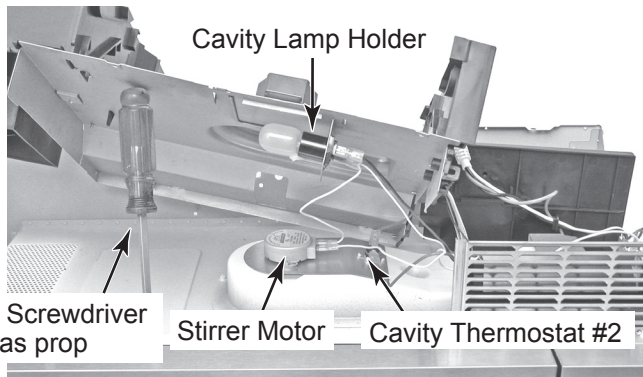

11. **To remove the cavity lamp holder (see the top-right photo):**

- a) Remove the Selastic™ from the bulb and the base of the lamp holder.
- b) Remove the bulb from the lamp holder.
- c) Disconnect the two wire connectors from the lamp holder terminals.
- d) Rotate the lamp holder clockwise to release the base from the mounting bracket and remove the cavity lamp holder.

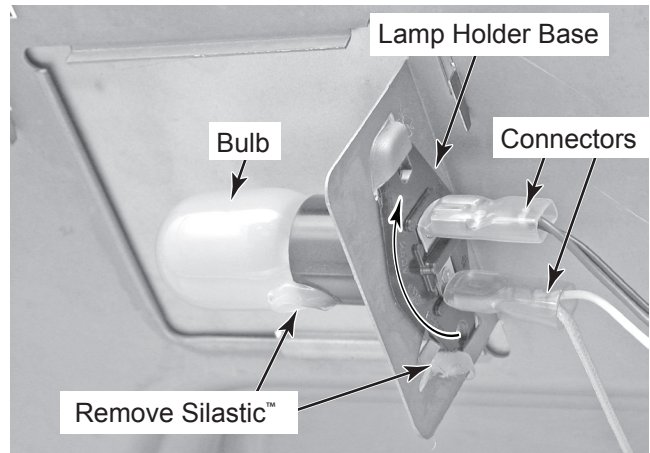

12. **To remove the stirrer motor and cavity thermostat #2:**

- a) Remove the two screws from the stirrer motor.
- b) Lift the stirrer motor straight up so that the fan pulls off the motor shaft, and remove the motor.

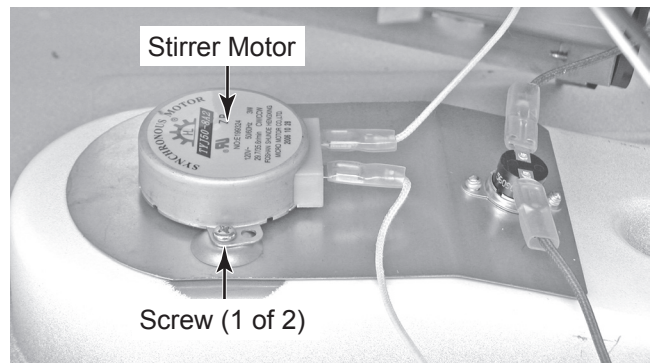

- c) Depending on which component you are servicing, disconnect the wire connectors from the stirrer motor or cavity thermostat #2 terminals, and remove the component from the oven.

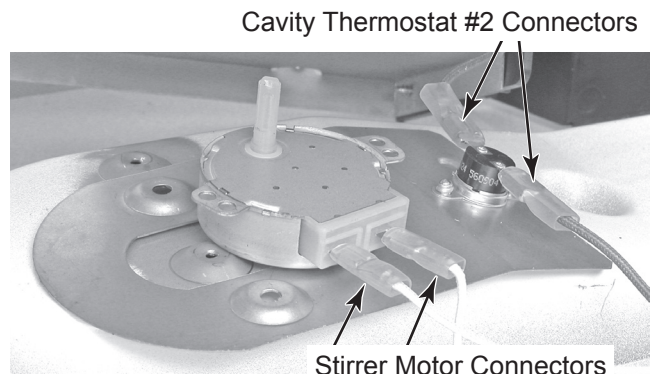

- d) Open the microwave oven door.
- e) Using a putty knife, pry the stirrer motor cover, and the plastic nails, off the top of the oven cavity. **NOTE:** The cover is sealed to the top by a Silastic™ adhesive. Also, the stirrer fan will be loose when you remove the cover.

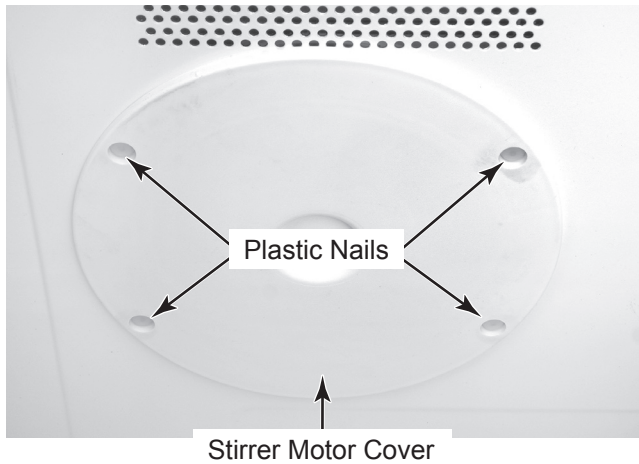

- f) Use the putty knife and scrape the old Silastic™ from around the stirrer fan opening. Use a piece of fine sandpaper to clean any debris from the surface.

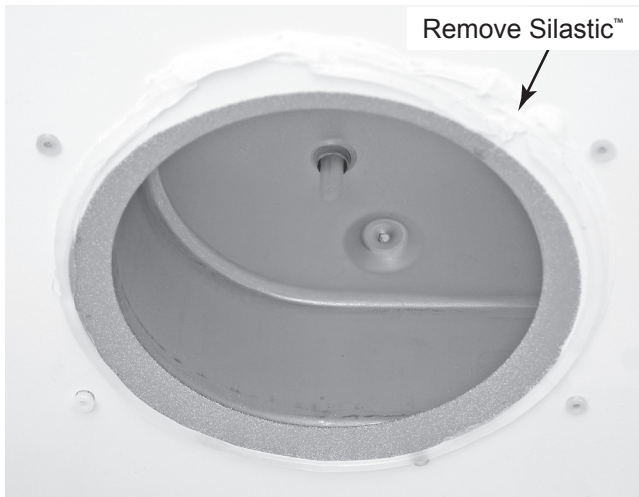

**REASSEMBLY NOTES:**

- Be sure to reinstall the stirrer fan blade on the motor shaft before you reinstall the cover.

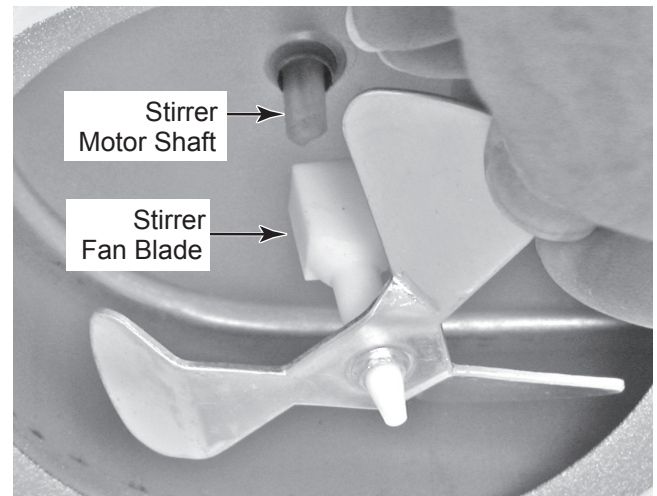

- Apply a 1/8" bead of Silastic™ around the stirrer motor cover opening. Make sure that the bead goes completely around the opening with no breaks, so that a complete seal is made between the cover and the top of the oven cavity. Install the plastic nails into the bushings after the cover is in place.

# REMOVING CAVITY THERMOSTAT #1, THE MOTOR CAPACITOR, THE AC LINE FILTER AND THE POWER SUPPLY CORD

## ⚠ WARNING



### Electrical Shock Hazard

Disconnect power before servicing.

Replace all parts and panels before operating.

Failure to do so can result in death or electrical shock.

1. Unplug microwave oven or disconnect power.
2. Remove the microwave oven from its mounting location (see page 2-4 for the procedure and reverse the procedure).
3. Remove the cabinet from the oven (see page 4-4 for the procedure).

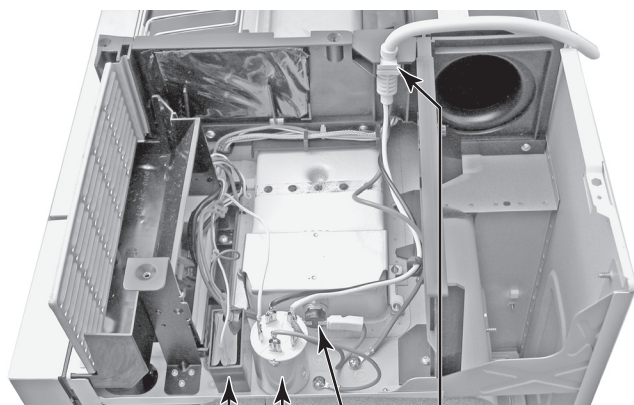

Motor Capacitor  
AC Line Filter  
Cavity Thermostat #1  
Power Supply Cord

4. To remove cavity thermostat #1:
  - a) Disconnect the two wire connectors from the cavity thermostat terminals.
  - b) Remove the two cavity thermostat bracket nuts and remove the thermostat.

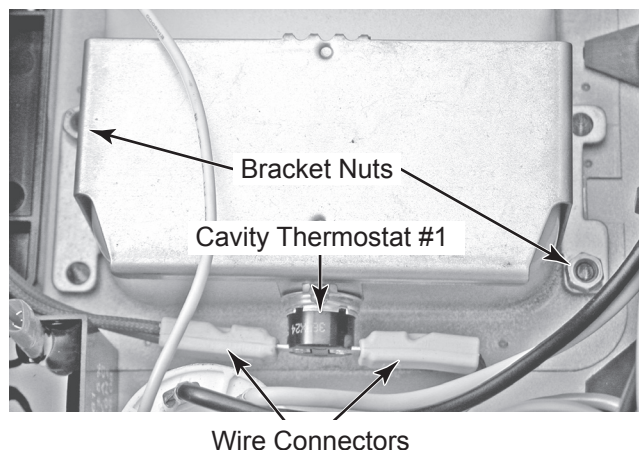

5. To remove the motor capacitor:
  - a) Discharge the capacitor by touching the leads of a 20,000  $\Omega$  resistor from each of the capacitor leads to the chassis ground.
  - b) Disconnect the two wire connectors from the capacitor terminals.
  - c) Remove the capacitor screw and remove the capacitor.

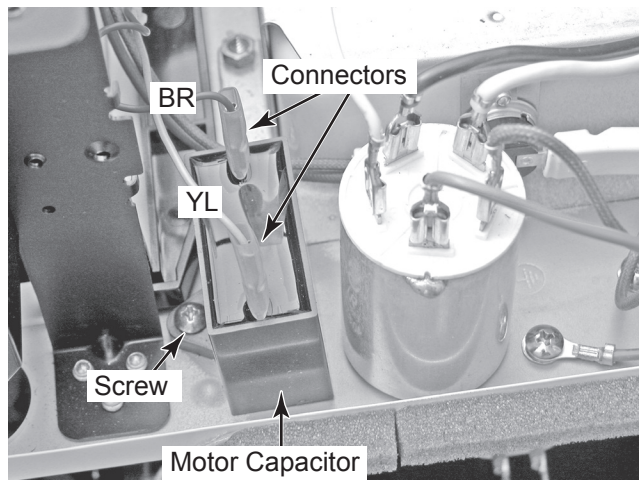



6. **To remove the AC line filter:**

- a) Discharge the AC line filter by touching the leads of a 20,000  $\Omega$  resistor from each of the filter leads to chassis ground.
- b) Disconnect the wire connectors from the filter terminals.
- c) Remove the nut and washer from the bottom of the AC line filter and remove the filter.

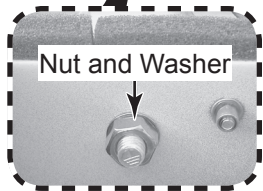
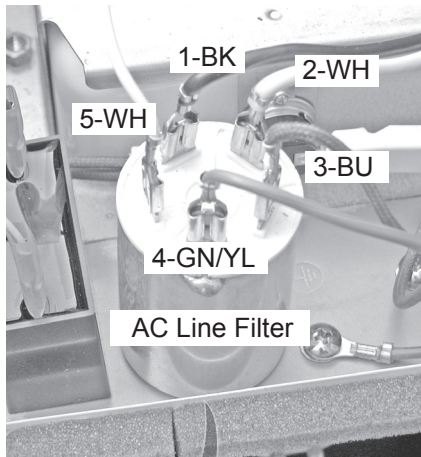

7. **To remove the power supply cord:**

- a) Discharge the AC line filter by touching the leads of a 20,000  $\Omega$  resistor from each of the filter leads to the chassis ground.
- b) Disconnect the black and white wire power supply cord connectors from filter terminals 1 and 2.
- c) Remove the screw from the green (ground) power supply cord wire.
- d) Slide the power supply cord off the right front air duct and remove the cord.

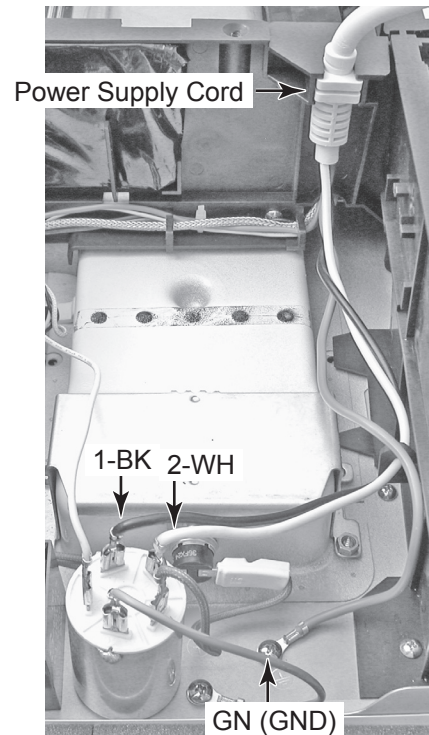

# REMOVING THE ELECTRONIC CONTROL BOARD AND THE TOUCH CONTROL ASSEMBLY

## ⚠ WARNING



### Electrical Shock Hazard

Disconnect power before servicing.

Replace all parts and panels before operating.

Failure to do so can result in death or electrical shock.

1. Unplug microwave oven or disconnect power.
2. Remove the microwave oven from its mounting location (see page 2-4 for the procedure and do procedure in reverse).
3. Remove the two screws from the front air vent, pull forward, and remove the vent from the oven.

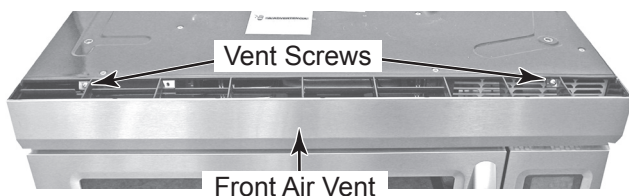

4. Remove the top screw from the control panel. Open the oven door, lift the panel, unhook the side latching tabs from the slots, and tilt the panel forward.

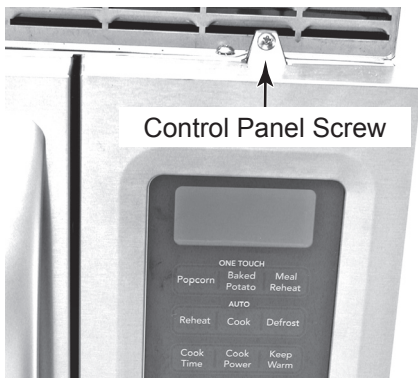

5. Disconnect the 3-wire humidity sensor cable (red, white and black) from humidity sensor connector P1.

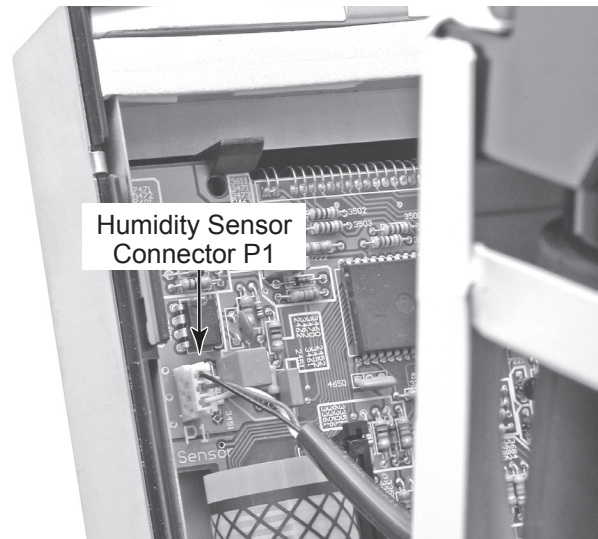

6. Lift the control panel and unhook the bottom bracket from the slot in the chassis. Rotate the panel so you can access the electronic control board wiring.
7. Disconnect wire connectors P2 through P4 from the electronic control board.
8. Disconnect the red and brown wires from terminals of relay 4903.
9. Remove the green ground wire screw and remove the control panel.

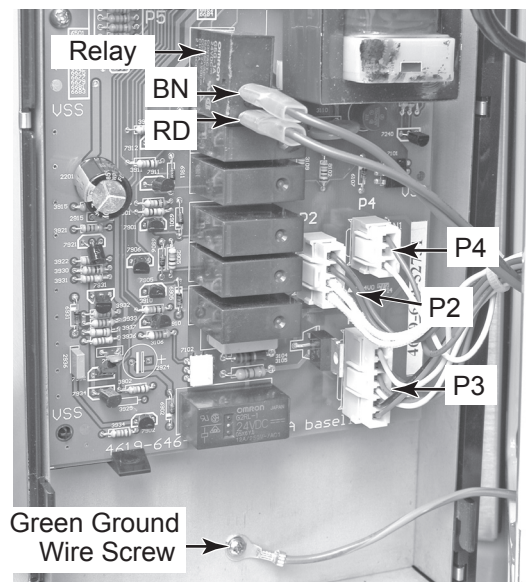

10. To remove the electronic control board:

- a) Lift the locking arm on ribbon cable connector P5 and pull the cable out of the connector.
- b) Remove the four screws from the electronic control board.
- c) Release the two locking tabs and remove the electronic control board from the panel.

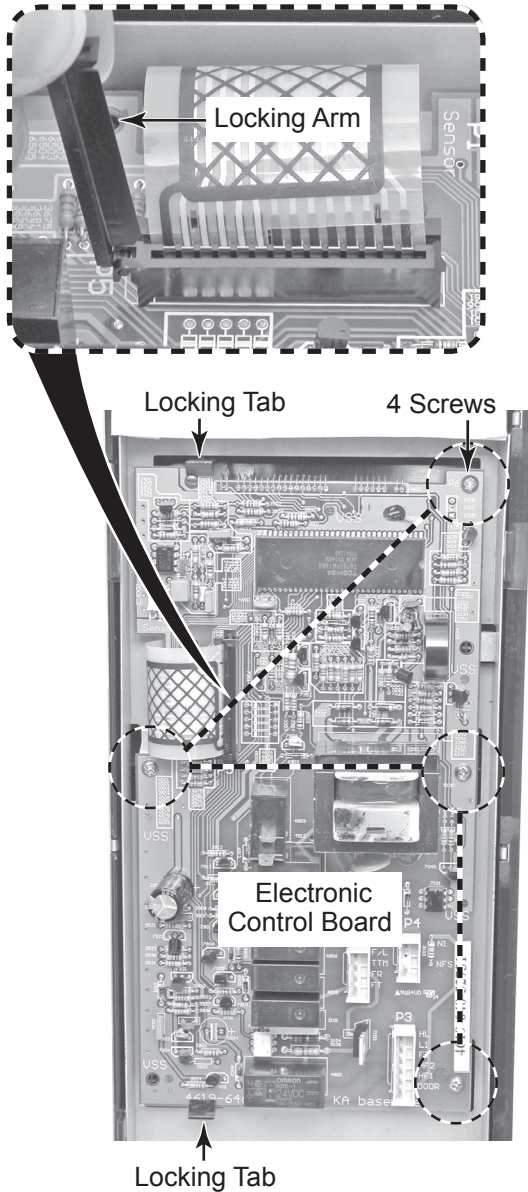

11. To remove the touch control assembly:

- a) Remove the electronic control board (see step 10).
- b) Release the two locking tabs and remove the metal shield from the control panel. **NOTE:** The control panel and the touch panel are replaced as one assembly.

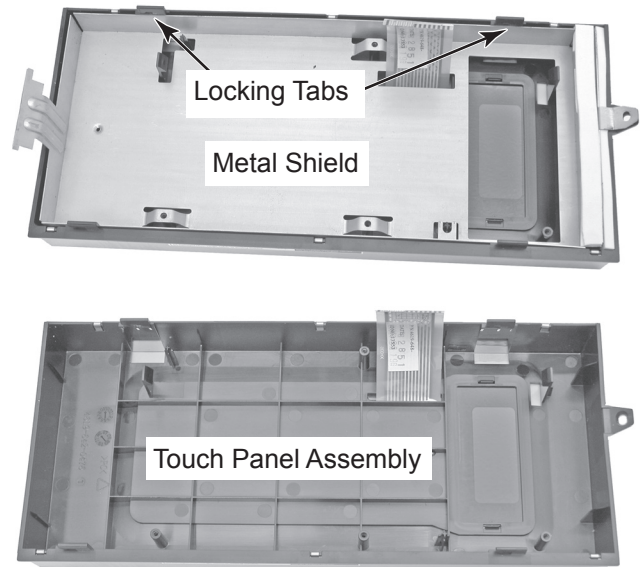

# REMOVING THE PRIMARY, SECONDARY, AND MONITOR INTERLOCK SWITCHES

## ⚠ WARNING



### Electrical Shock Hazard

Disconnect power before servicing.

Replace all parts and panels before operating.

Failure to do so can result in death or electrical shock.

1. Unplug microwave oven or disconnect power.
2. Remove the control panel from the oven (see page 4-14 for the procedure).

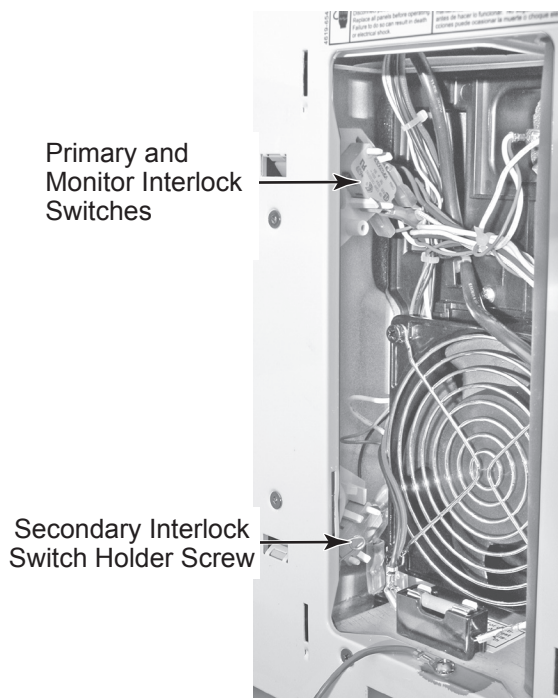

3. **To remove the monitor interlock switch:**
  - a) Open the microwave oven door.
  - b) Place the blade of a standard screwdriver between one of the pins and the locking tab.

- c) While pulling out on the switch, pry up on the locking tab so that it clears the switch.
- d) Repeat the previous step for the other pin and locking tab, and slide the switch off the holder pins.

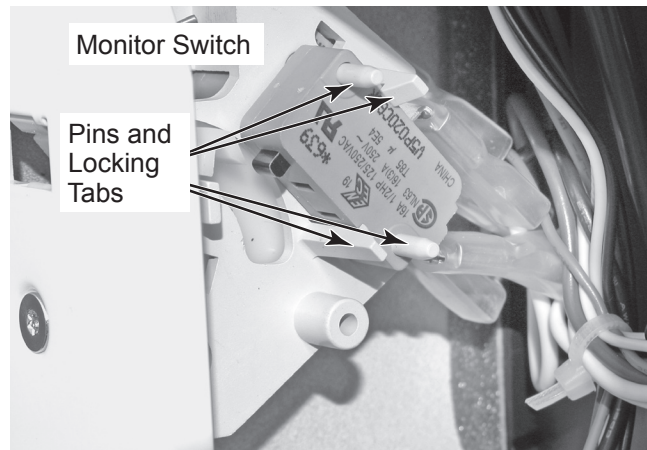

- e) Press down on the locking tabs, and disconnect the red (NC2) and white (C1) wires from the switch terminals.

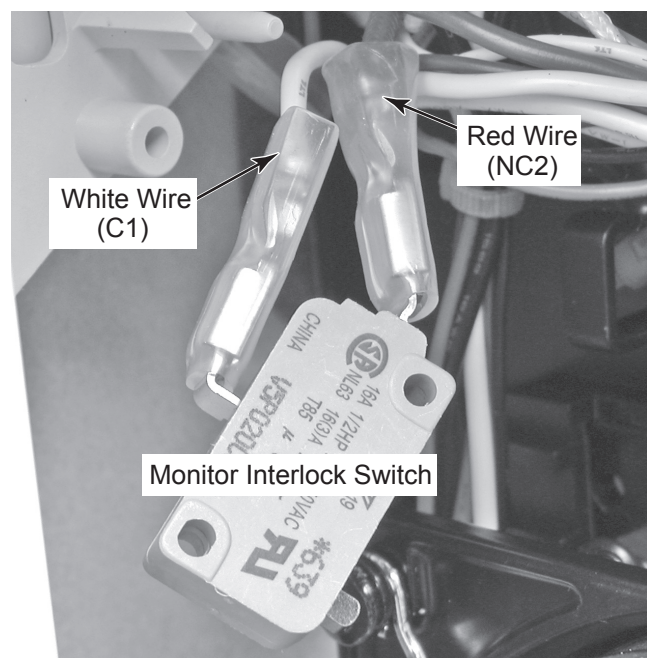

4. **To remove the primary or secondary interlock switch:**

- a) Open the microwave oven door.
- b) Remove the screw from the front of the chassis for the switch you are removing.
- c) Depending on the switch you are removing, rotate the switch holder locking cam in the direction of the arrow. This will unlock the switch holder from the chassis.
- d) Remove the primary or secondary inter-lock switch holder from the oven.

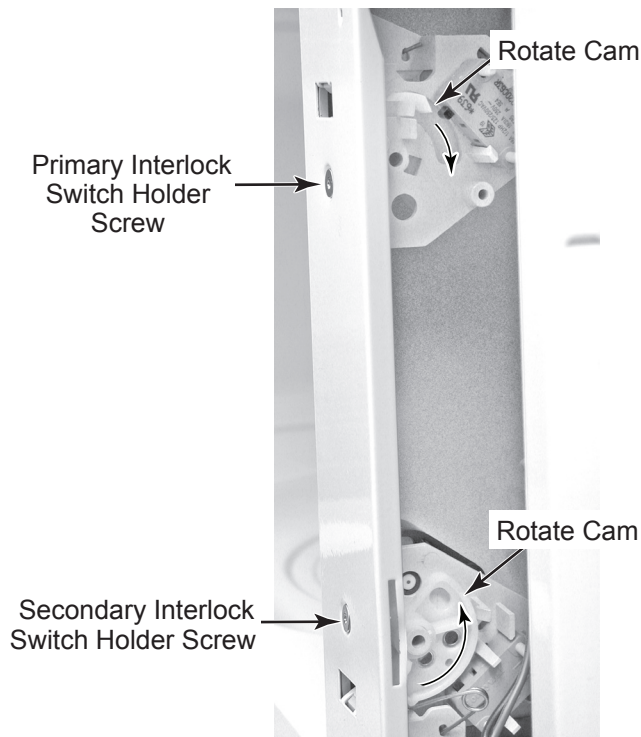

- e) Remove the primary or secondary interlock switch from its holder. To remove the switch, refer to step 3.
- f) *Primary Interlock Switch:* Press down on the locking tabs, and disconnect the orange (NC2), brown and white (NC4), and black (C1) wires from the switch terminals (see the upper-right photo).

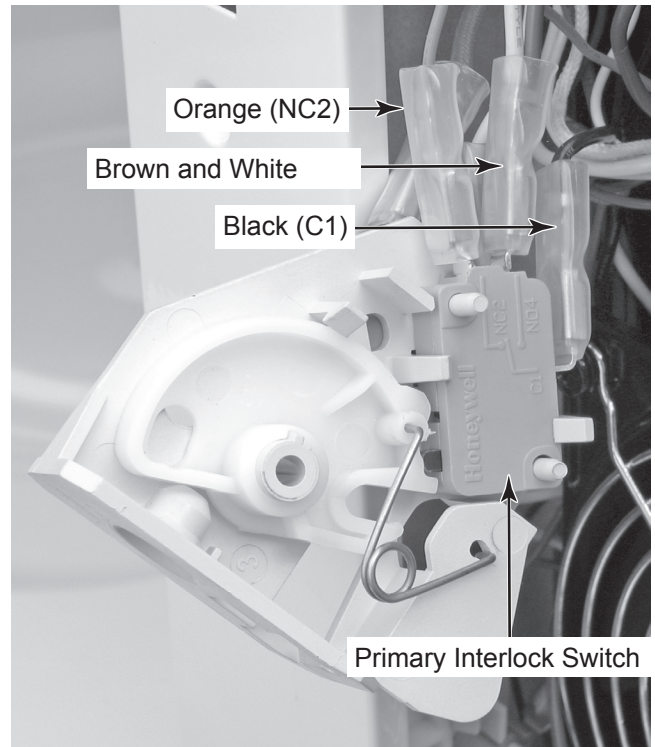

- g) *Secondary Interlock Switch:* Press down on the locking tabs, and disconnect the blue & white (NC2) and blue & black (C1) wires from the switch terminals.

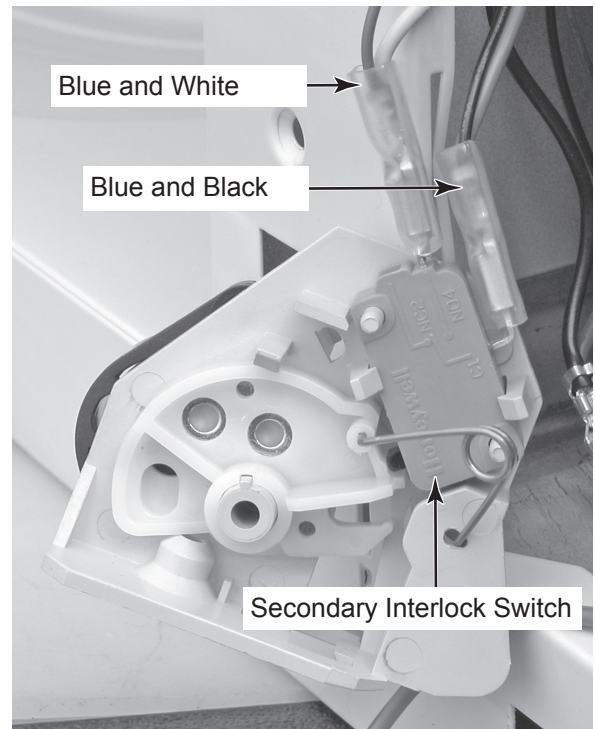

**REASSEMBLY NOTE:** Be sure to rotate the switch cam back to its original position after you reinstall the switch holder on the oven chassis.

# REMOVING THE LINE FUSE HOLDER AND THE MAGNETRON THERMOSTAT

## ⚠ WARNING



### Electrical Shock Hazard

Disconnect power before servicing.

Replace all parts and panels before operating.

Failure to do so can result in death or electrical shock.

1. Unplug microwave oven or disconnect power.
2. Remove the control panel from the oven (see page 4-14 for the procedure).

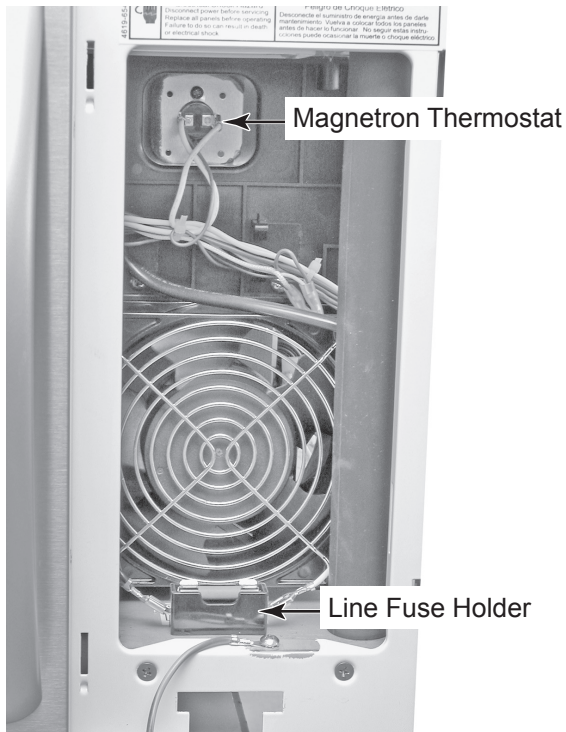

3. To remove the line fuse holder:
  - a) Remove the line fuse from the fuse holder.
  - b) Disconnect the two wire connectors from the fuse holder terminals.

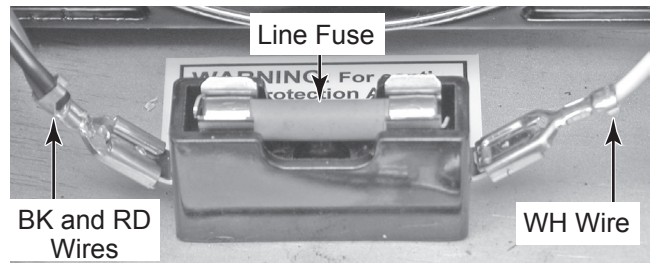

- c) Remove the screw from the fuse holder and remove the holder from the oven.

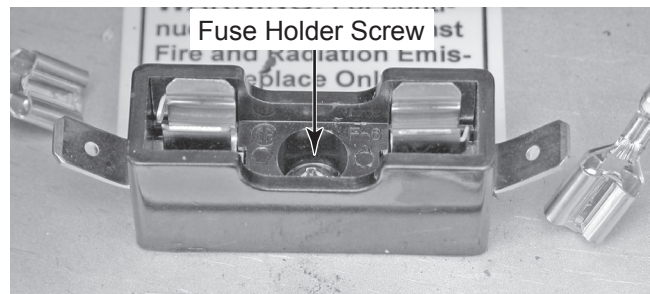

4. To remove the magnetron thermostat:
  - a) Disconnect the two wires from the magnetron thermostat terminals.
  - b) Remove the screws from the magnetron thermostat and remove the thermostat.

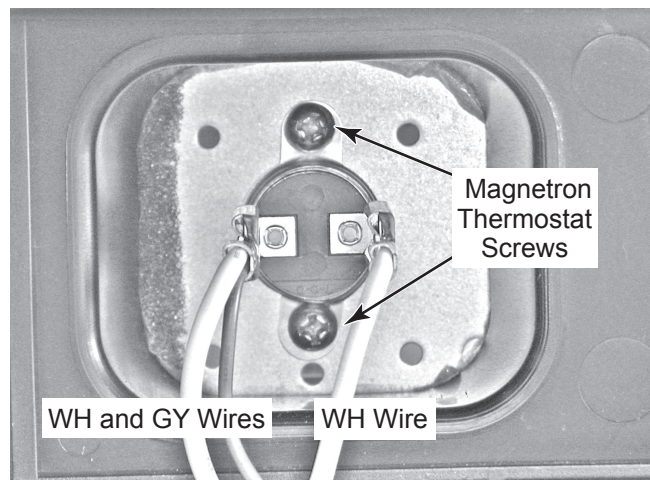

# REMOVING THE COOLING FAN MOTOR AND THE EXHAUST FAN THERMOSTAT

## ⚠ WARNING



**Electrical Shock Hazard**  
**Disconnect power before servicing.**  
**Replace all parts and panels before operating.**  
**Failure to do so can result in death or electrical shock.**

1. Unplug microwave oven or disconnect power.
2. Remove the control panel from the oven (see page 4-14 for the procedure).

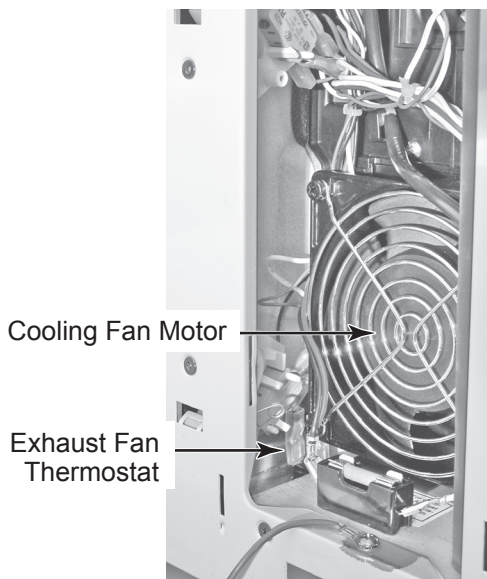

3. **To remove the cooling fan motor:**
  - a) Remove the two right screws from the fan motor (see the top-right photo).
  - b) Disconnect the two wires from the fan motor terminals.
  - c) Pull the cooling fan motor to the right, unhook the left side from the bracket, and remove the motor from the oven.

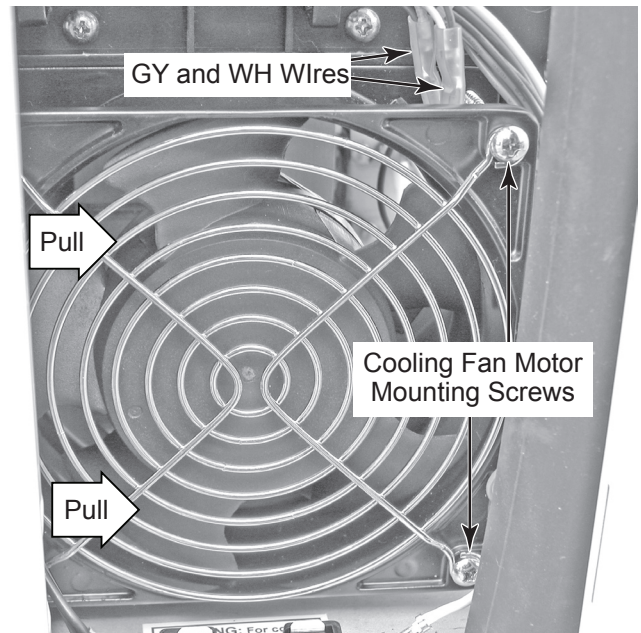

4. **To remove the exhaust fan thermostat:**
  - a) Remove the cooling fan motor (see step 3).
  - b) Disconnect the two wires from the exhaust fan thermostat terminals.
  - c) Remove the screws from the exhaust fan thermostat and remove the thermostat.

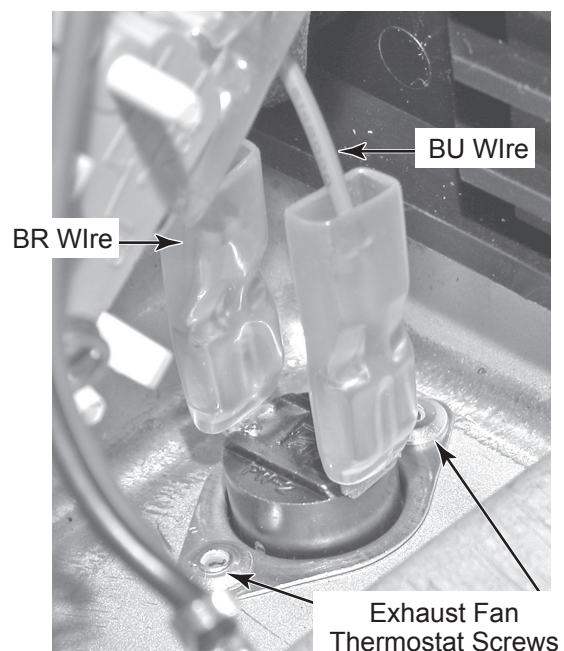

# REMOVING THE HIGH-VOLTAGE DIODE AND THE POWER RESISTOR

## **! WARNING**



### **Electrical Shock Hazard**

**Disconnect power before servicing.**

**Replace all parts and panels before operating.**

**Failure to do so can result in death or electrical shock.**

1. Unplug microwave oven or disconnect power.
2. Remove the microwave oven from its mounting location (see page 2-4 for the procedure and reverse the procedure).
3. Remove the cabinet from the oven (see page 4-4 for the procedure).

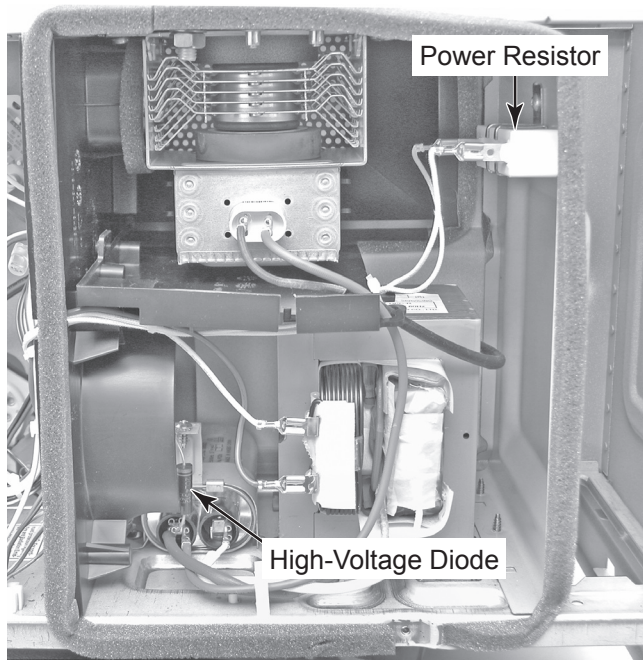

### 4. To remove the high voltage diode:

- a) Discharge the high voltage capacitor by touching the leads of a 20,000  $\Omega$  resistor from each of the capacitor leads to the chassis ground.
- b) Disconnect the high voltage diode connector from the high voltage capacitor terminal.
- c) Remove the Screw and Washer from the high voltage diode and remove the diode from the high voltage capacitor.

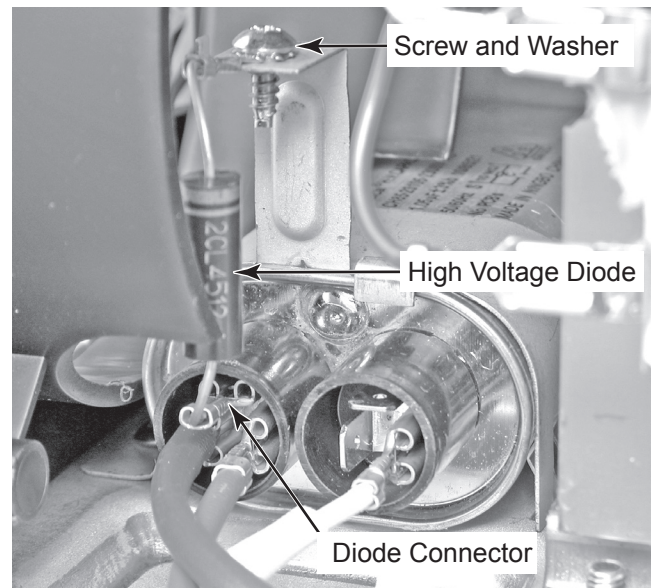

### 5. To remove the power resistor:

- a) Disconnect the wire connectors from the power resistor terminals.
- b) Remove the screw from the power resistor and remove the resistor from the oven.

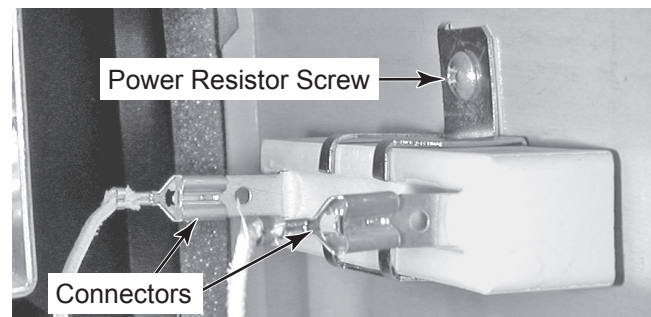



# REMOVING THE HIGH-VOLTAGE CAPACITOR AND THE MAGNETRON

## **⚠ WARNING**



**Electrical Shock Hazard**  
**Disconnect power before servicing.**  
**Replace all parts and panels before operating.**  
**Failure to do so can result in death or electrical shock.**

1. Unplug microwave oven or disconnect power.
2. Remove the microwave oven from its mounting location (see page 2-4 for the procedure and reverse the procedure).
3. Remove the cabinet from the oven (see page 4-4 for the procedure).

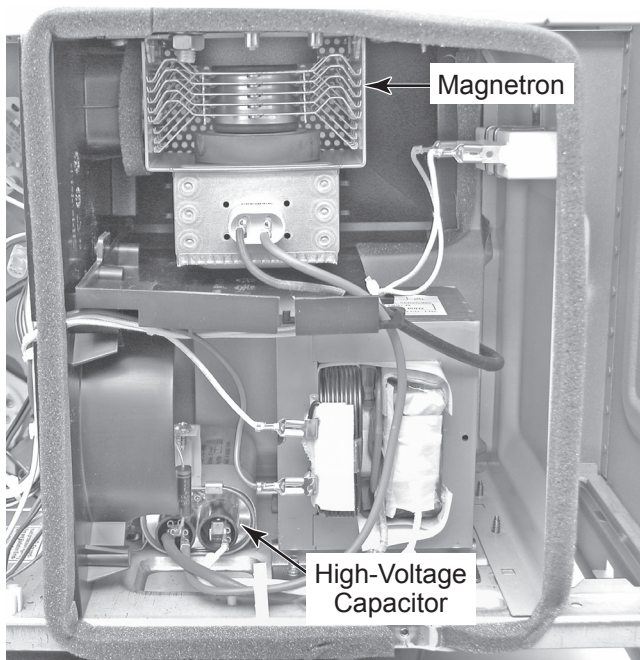

4. Remove the cooling fan motor from the oven (see page 4-19 for the procedure).
5. Unclip the wiring from the front of the cooling fan motor shroud.
6. Remove the two top, front, and bottom screws (6 total) from the fan shroud.

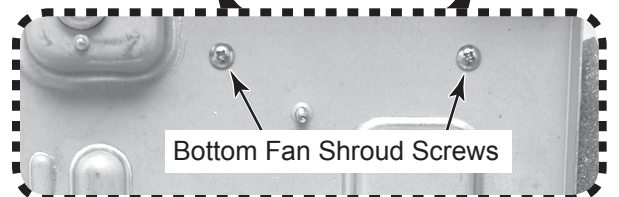
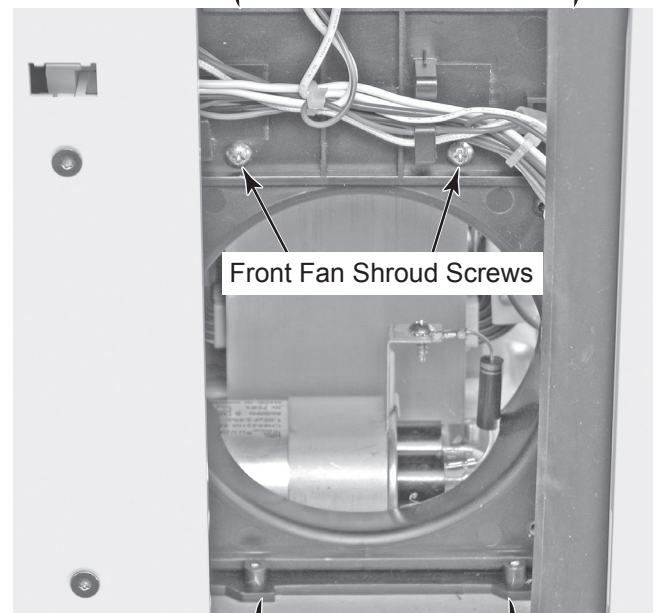
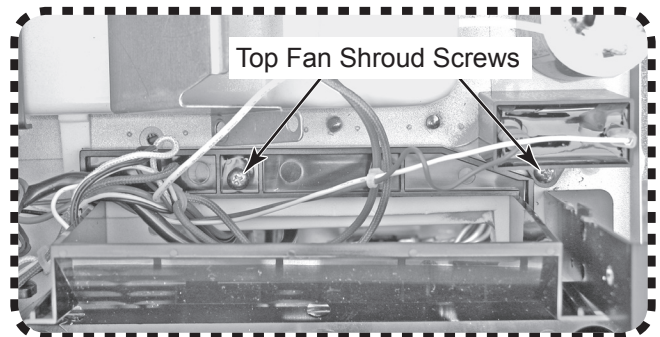

**Continued on the next page.**

7. Cut the foam tape at the three indicated locations on the side of the cooling fan shroud.
8. Disconnect the red and white wires from the high-voltage transformer terminals.
9. Disconnect the two wires from the power resistor terminals.
10. Cut the wire tie from around the power resistor wires.
11. Remove the resistor wires and the red and white high-voltage transformer wires from the cooling fan shroud.

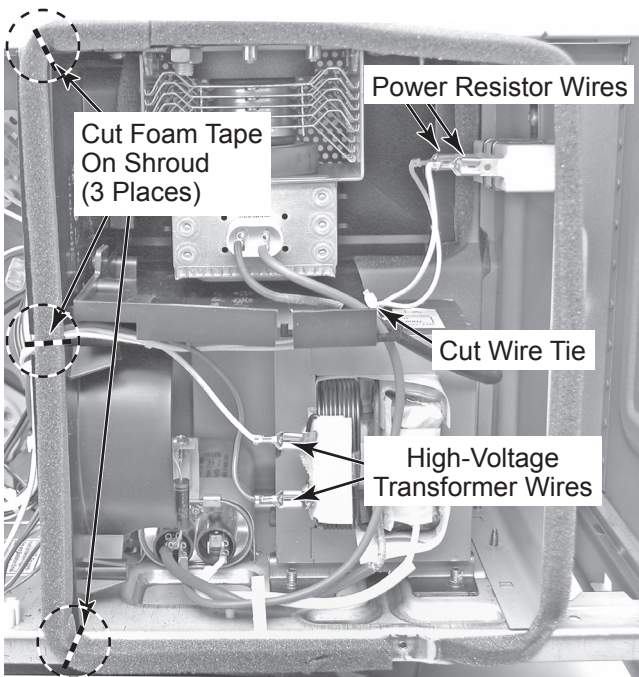

12. Slide the cooling fan motor shroud out of the oven.
13. **To remove the high-voltage capacitor:**
  - a) Discharge the high-voltage capacitor by touching the leads of a 20,000  $\Omega$  resistor from each of the capacitor leads to chassis ground.
  - b) Remove the high-voltage diode from the capacitor (see page 4-20 for the procedure).

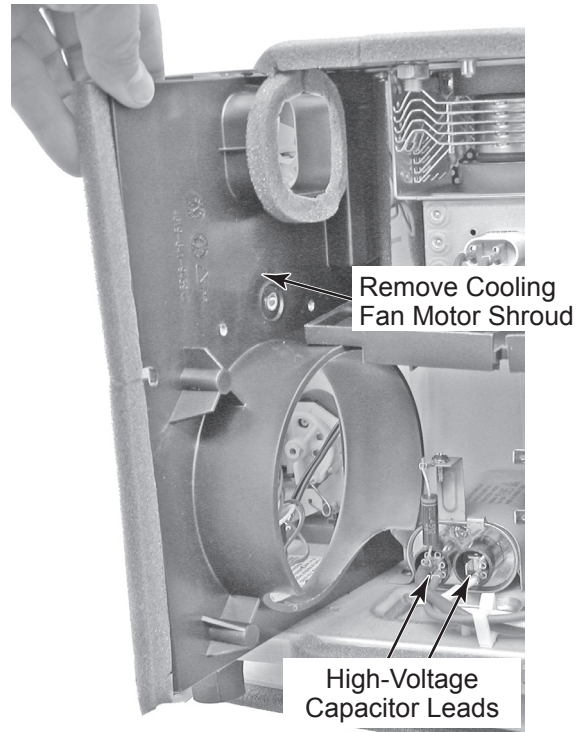

- c) Disconnect the wire connectors from the high-voltage capacitor terminals.
- d) Loosen the bracket screw, slide the high-voltage capacitor out of the bracket, and remove the capacitor.

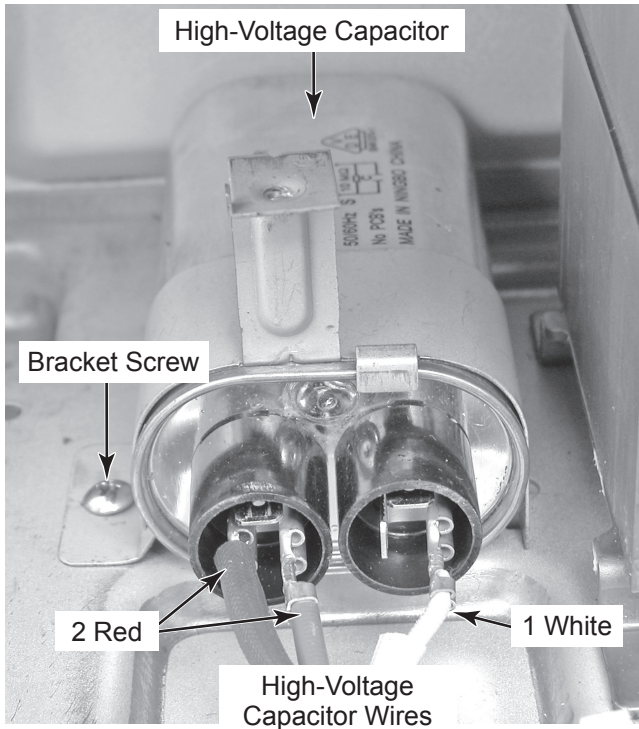

14. **To remove the magnetron:**

- a) Discharge the high voltage capacitor by touching the leads of a 20,000  $\Omega$  resistor from each of the capacitor leads to the chassis ground.
- b) Remove the mounting bracket and cavity thermostat #1 (see page 4-12 for the procedure).
- c) Remove the magnetron thermostat from the magnetron (see page 4-18 for the procedure).
- d) Disconnect the filament wire connectors from the magnetron terminals.
- e) Remove the four screws from the magnetron and remove the magnetron from the oven.

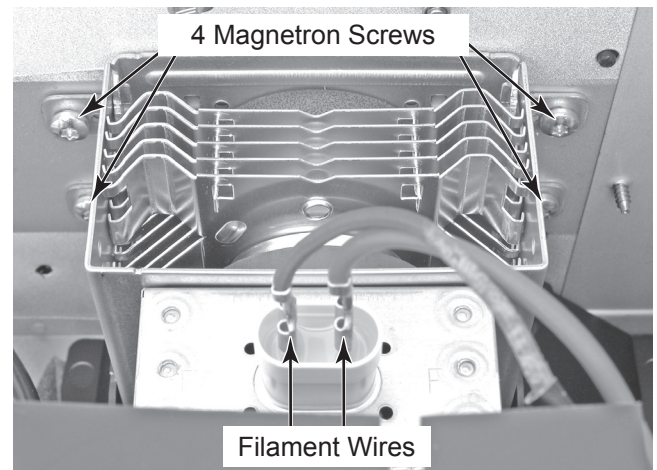

# REMOVING THE HIGH-VOLTAGE TRANSFORMER

## ⚠ WARNING



### Electrical Shock Hazard

Disconnect power before servicing.  
Replace all parts and panels before operating.

Failure to do so can result in death or electrical shock.

1. Unplug microwave oven or disconnect power.
2. Remove the microwave oven from its mounting location (see page 2-4 for the procedure and do procedure in reverse).
3. Remove the cabinet from the oven (see page 4-4 for the procedure).

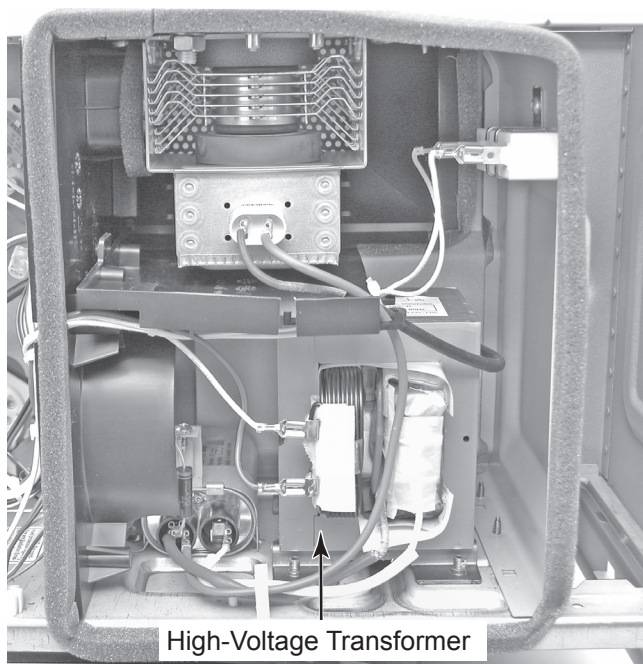

4. Discharge the high-voltage capacitor by touching the leads of a 20,000  $\Omega$  resistor from each of the capacitor leads to chassis ground.
5. Disconnect the high-voltage transformer wires from the following locations:
  - a) The red wire from the magnetron filament terminal.
  - b) The red and white wires from the transformer terminals.
  - c) The red and white wires from the high-voltage capacitor terminals.
6. Remove the four high-voltage transformer screws from the bottom of the chassis and remove the transformer.

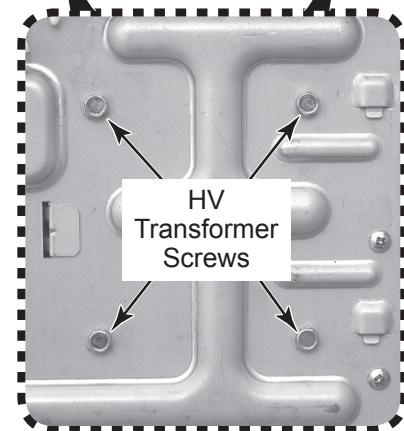
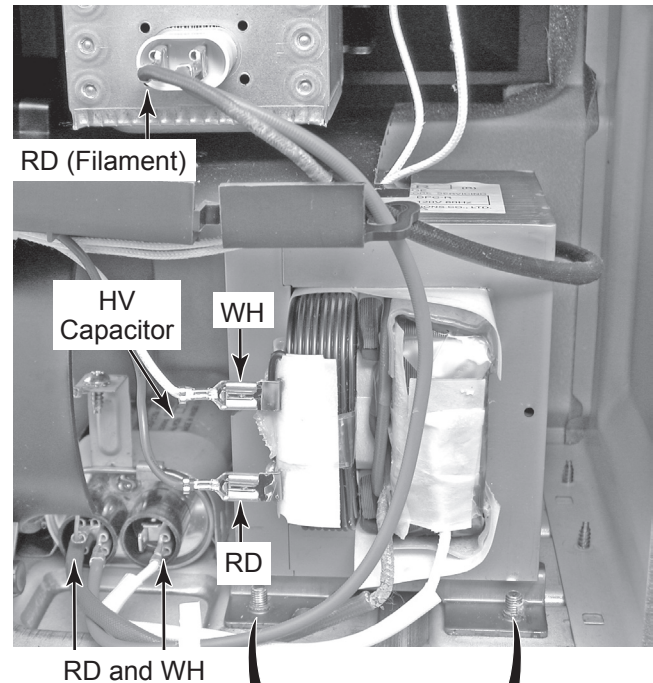

## REMOVING THE TURNTABLE MOTOR

### **⚠ WARNING**



#### **Electrical Shock Hazard**

**Disconnect power before servicing.**

**Replace all parts and panels before operating.**

**Failure to do so can result in death or electrical shock.**

1. Unplug microwave oven or disconnect power.
2. Open the microwave oven door, remove the turntable platter, rollers, and spindle, and close the door.

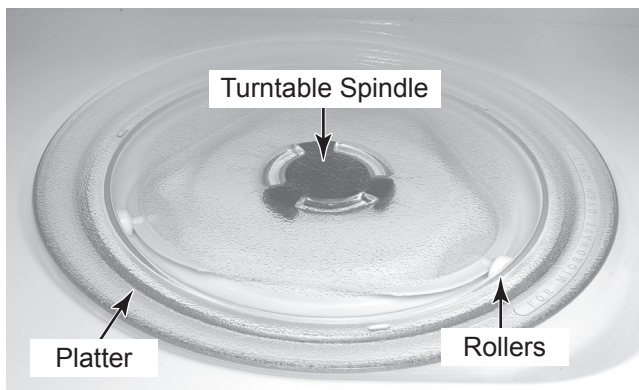

3. Remove the ten screws from the bottom cover and lower the cover.

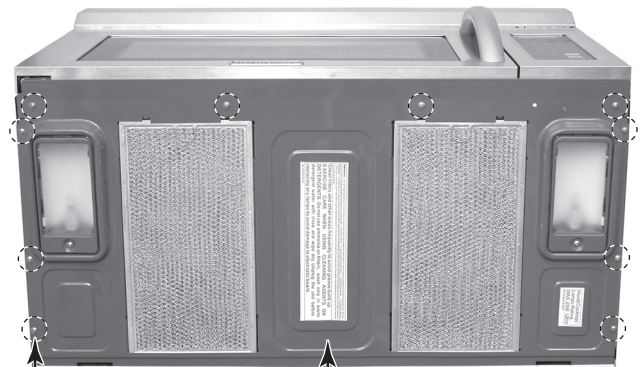

Screw (1 of 10) Bottom Cover Assembly

4. Disconnect the wire connector from the turntable motor terminals.
5. Remove the two screws from the turntable motor and remove the motor.

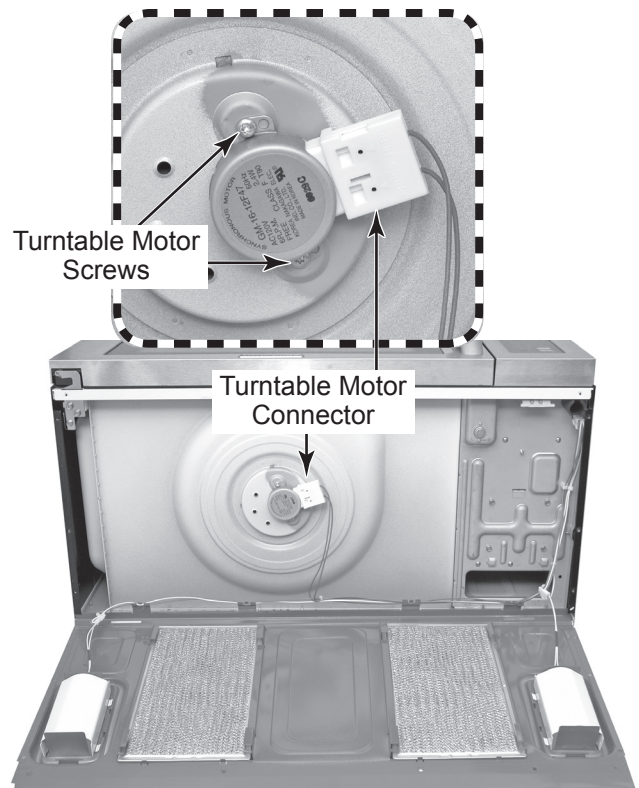

# REMOVING THE OVEN DOOR AND COMPONENTS

## **⚠ WARNING**



### **Electrical Shock Hazard**

**Disconnect power before servicing.**

**Replace all parts and panels before operating.**

**Failure to do so can result in death or electrical shock.**

1. Unplug microwave oven or disconnect power.
2. Open the microwave oven door.
3. Pry the choke cover away from the top door pin, and remove the top pin from the pivot bracket. Lift the door off the bottom bracket, and remove it.

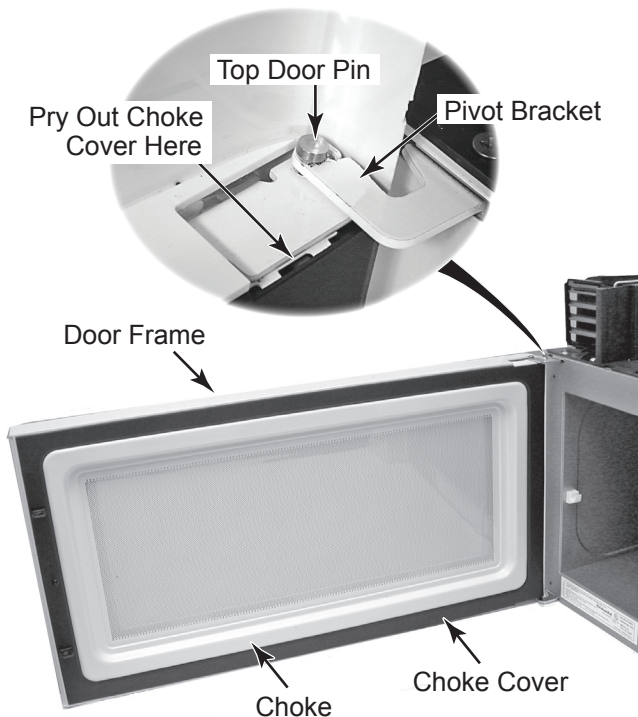

4. Place the oven door front side down on a padded surface.
5. Remove the choke screws from the door frame.

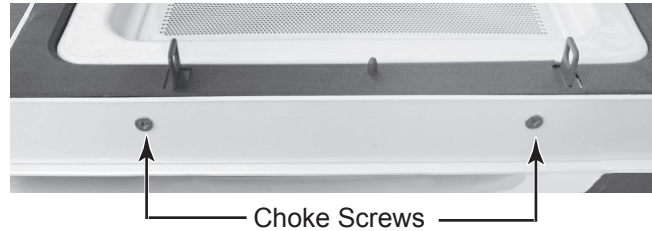

6. Starting at the top right corner (see the round inset photo in the left column), pry the choke cover out with a putty knife, and unsnap it from the choke. Only remove the top, bottom and right sides of the choke cover at this time. You will remove the handle end of the choke cover later.

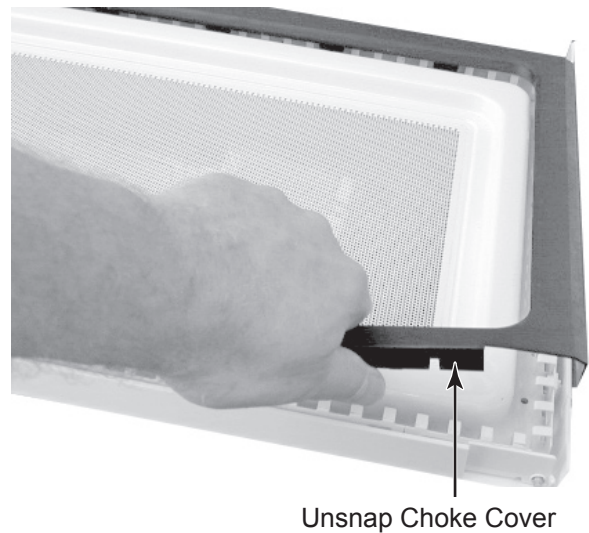

7. Starting at the top edge of the door near the center and working clockwise, use a putty knife, and pry the latching tabs of the choke out of the door frame slots. Lift the choke as you release the tabs so they do not snap back into the slots. **NOTE:** When you reach the handle side of door, pull both the choke and the choke cover away from the door frame, and then separate the two components.



8. To remove the door switch actuators from the choke, remove the screw from each actuator.

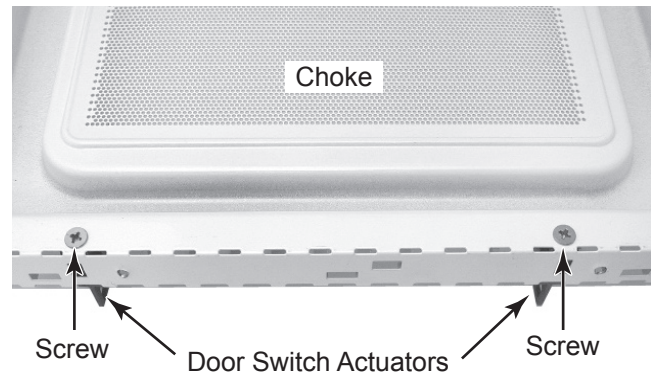

#### DOOR COMPONENTS

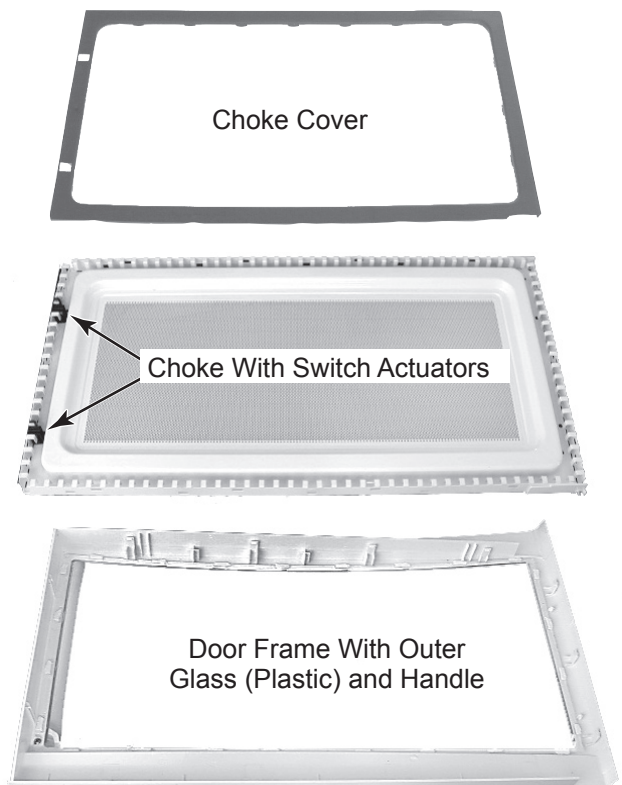

**REASSEMBLY NOTE:** When you reinstall the door on the oven, insert the top pin into the pivot bracket and press down on the pin until it snaps into place.

— NOTES —



# COMPONENT TESTING

**IMPORTANT:** Before performing any tests on the microwave oven, be sure to observe the following:

- Unplug microwave oven or disconnect power.
- Remove the lead wires from the related component before conducting any of the following tests.
- All operational checks using microwave energy must be done with the microwave oven loaded with a minimum of 10 oz. (300 mL) of water in a microwave-safe container.
- Conduct a microwave energy test after performing any tests or repairs to the microwave oven.
- Check that all wire leads are in the correct position before operating the microwave oven.
- Grasp wire connectors when removing the wire leads from microwave oven parts.
- All testing must be done with an ohmmeter having a sensitivity of 20,000 ohms-per-volt DC or greater and powered by at least a 9-volt battery.

	<b>! WARNING</b>
	<b>Electrical Shock Hazard</b> <b>Disconnect power before servicing.</b> <b>Replace all parts and panels before operating.</b> <b>Failure to do so can result in death or electrical shock.</b>

## THERMOSTATS



Refer to the following pages for the procedures for accessing the thermostats:

- Cavity Thermostat #3, page 4-5
- Cavity Thermostat #2, page 4-9
- Cavity Thermostat #1, page 4-12
- Magnetron Thermostat, page 4-18
- Exhaust Fan Thermostat, page 4-19

1. Unplug microwave oven or disconnect power.
2. Disconnect one of the wires from the thermostat terminals.
3. Set the ohmmeter to the R x 1 scale.
4. *Exhaust Fan Thermostat:* Touch the ohmmeter test leads to the thermostat terminals. The meter should indicate an open (infinite) circuit.
5. *All Other Thermostats:* Touch the ohmmeter test leads to the thermostat terminals. The meter should indicate a closed (0  $\Omega$ ) circuit.

# ⚠ WARNING



## Electrical Shock Hazard

Disconnect power before servicing.

Replace all parts and panels before operating.

Failure to do so can result in death or electrical shock.

## HUMIDITY SENSOR



Refer to page 4-5 for the procedure for accessing the humidity sensor.

1. Unplug microwave oven or disconnect power.
2. Disconnect the humidity sensor 3-wire connector from the control board at P1.
3. Set the ohmmeter to the R x 1K scale.
4. Touch the ohmmeter test leads to sensor connector pins 1 and 3, and then 2 and 3. The meter should indicate approximately 2.8 K $\Omega$  @ 77°F (25°C).

## HOOD EXHAUST FAN MOTOR

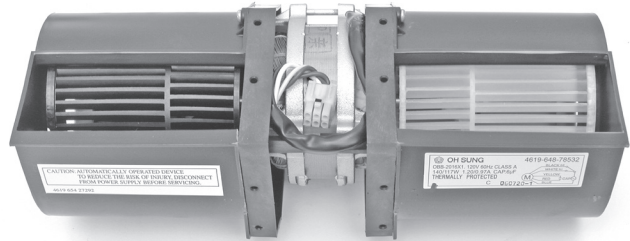

Refer to page 4-8 for the procedure for accessing the hood exhaust fan motor.

1. Unplug microwave oven or disconnect power.
2. Disconnect the hood exhaust fan motor wire connector from the main harness.
3. Set the ohmmeter to the R x 1 scale.
4. Touch the ohmmeter test leads to the following hood exhaust fan motor plug pins:

High Speed: Red and blue wires = 79 to 119  $\Omega$ .

High Speed: Blue and black wires = 22 to 43  $\Omega$ .

Low Speed: Red and blue wires = 79 to 119  $\Omega$ .

Low Speed: Blue and white wires = 43 to 62  $\Omega$ .

# **⚠ WARNING**



## **Electrical Shock Hazard**

**Disconnect power before servicing.**

**Replace all parts and panels before operating.**

**Failure to do so can result in death or electrical shock.**

## **STIRRER MOTOR**

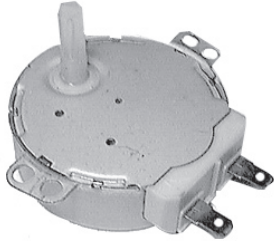

Refer to page 4-9 for the procedure for accessing the stirrer motor.

1. Unplug microwave oven or disconnect power.
2. Disconnect the stirrer motor wires from the motor terminals.
3. Set the ohmmeter to the R x 1K scale.
4. Touch the ohmmeter test leads to the motor terminals. The meter should indicate between 2700 and 4200  $\Omega$ .

## **MOTOR CAPACITOR**

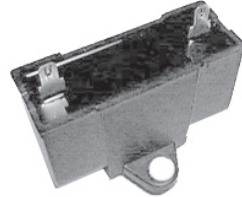

Refer to page 4-12 for the procedure for accessing the motor capacitor.

1. Unplug microwave oven or disconnect power.
2. Discharge the capacitor by touching the leads of a 20,000  $\Omega$  resistor from each of the capacitor leads to the chassis ground.
3. Disconnect the motor capacitor wires from the capacitor terminals.
4. Set the ohmmeter to the R x 1 scale.
5. Touch the ohmmeter test leads to the capacitor terminals. The meter should indicate several ohms and gradually return to infinity.

# ⚠ WARNING



## Electrical Shock Hazard

Disconnect power before servicing.

Replace all parts and panels before operating.

Failure to do so can result in death or electrical shock.

## AC LINE FILTER

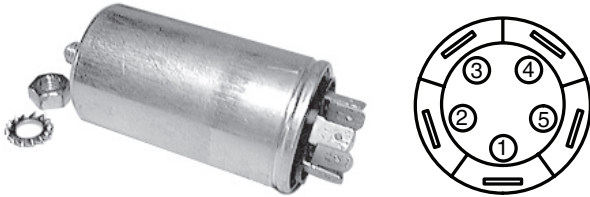

Refer to page 4-12 for the procedure for accessing the AC line filter.

1. Unplug microwave oven or disconnect power.
2. Discharge the AC line filter by touching the leads of a 20,000  $\Omega$  resistor from each of the filter leads to the chassis ground.
3. Disconnect the AC line filter wires from the filter terminals.
4. Set the ohmmeter to the R x 1 scale.
5. Touch the ohmmeter test leads to the following AC line filter terminals:  
1 to 3 (coil) = less than 1  $\Omega$ .  
2 to 4 (coil) = less than 1  $\Omega$ .
6. Set the ohmmeter to the R x 10K scale.
7. Touch the ohmmeter test leads to AC line filter terminals 3 and 4 (resistor). The meter should indicate between 550 K and 800 K $\Omega$ .

## DOOR INTERLOCK SWITCHES



Refer to page 4-16 for the procedure for accessing the door interlock switches.

1. Unplug microwave oven or disconnect power.
2. Disconnect the wires from the interlock switch terminals.
3. Set the ohmmeter to the R x 1 scale.
4. Touch the ohmmeter test leads to the terminals of the primary or secondary switch (normally open). The meter should indicate an open (infinite) circuit.
5. Touch the ohmmeter test leads to the terminals of the monitor switch (normally closed). The meter should indicate a closed (0  $\Omega$ ) circuit.

**NOTE:** Pressing the actuator button on the switches should result in opposite readings (normally open should read closed, and normally closed should read open).

# **WARNING**

## Electrical Shock Hazard

**Disconnect power before servicing.**

**Replace all parts and panels before operating.**

**Failure to do so can result in death or electrical shock.**



## LINE FUSE

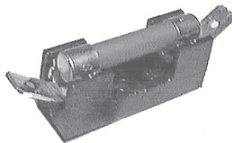

Refer to page 4-18 for the procedure for accessing the line fuse.

1. Unplug microwave oven or disconnect power.
2. Disconnect one of the wires from the fuse holder terminals.
3. Set the ohmmeter to the R x 1 scale.
4. Touch the ohmmeter test leads to the fuse holder terminals. The meter should indicate a closed (0  $\Omega$ ) circuit.

## COOLING FAN MOTOR



Refer to page 4-19 for the procedure for accessing the cooling fan motor.

1. Unplug microwave oven or disconnect power.
2. Disconnect one of the wires from the cooling fan motor terminals.
3. Set the ohmmeter to the R x 1 scale.
4. Touch the ohmmeter test leads to the cooling fan motor terminals. The meter should indicate between 90 and 135  $\Omega$ .



## ⚠ WARNING

### Electrical Shock Hazard

Disconnect power before servicing.

Replace all parts and panels before operating.

Failure to do so can result in death or electrical shock.

### HIGH-VOLTAGE DIODE

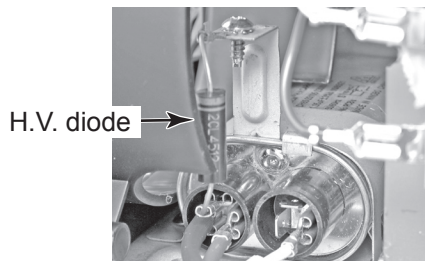

Refer to page 4-20 for the procedure for accessing the high-voltage (H.V.) diode.

**NOTE:** Some inexpensive ohmmeters do not have a 9-volt battery incorporated in them, and may indicate infinite resistance in both directions when testing the diode. It is recommended that you use an ohmmeter with a 9-volt battery on the R x 10 scale to properly test the H.V. diode.

1. Unplug microwave oven or disconnect power.
2. Discharge the high-voltage capacitor by touching the leads of a 20,000  $\Omega$  resistor from each of the capacitor leads to chassis ground.
3. Disconnect the H.V. diode lead from the high voltage capacitor terminal.
4. For ohmmeters without a 9-volt battery, prepare the DC 9-volt battery and 10 k $\Omega$  resistor in series including wire leads.
5. Connect the DC 9-volt battery to the H.V. diode.
6. Set the ohmmeter to the R x 10K scale.
7. Measure the continuity as follows (values are approximate):
  - Forward Direction: Normal: 5 to 6 volts.  
Abnormal: Open = 9 volts, short = 0 volts.
  - Reverse Direction: Normal: 9 volts.  
Abnormal: Open = 9 volts, short = 0 volts.

### POWER RESISTOR

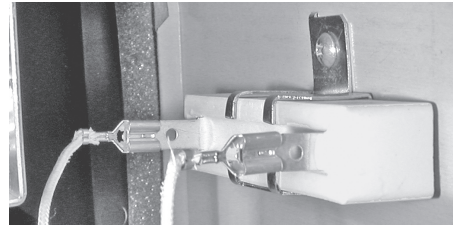

Refer to page 4-20 for the procedure for accessing the power resistor.

1. Unplug microwave oven or disconnect power.
2. Disconnect one of the wires from the power resistor terminals.
3. Set the ohmmeter to the R x 1 scale.
4. Touch the ohmmeter test leads to the filament terminals. The meter should indicate between 37 and 45  $\Omega$ .



## ! WARNING

### Electrical Shock Hazard

**Disconnect power before servicing.**  
**Replace all parts and panels before operating.**  
**Failure to do so can result in death or electrical shock.**

### HIGH-VOLTAGE CAPACITOR

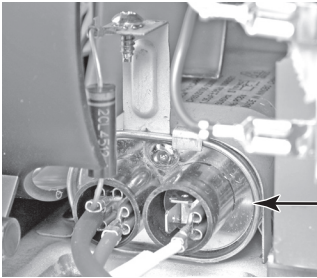

H.V. Capacitor

Refer to page 4-21 for the procedure for accessing the high-voltage capacitor.

1. Unplug microwave oven or disconnect power.
2. Discharge the high-voltage capacitor by touching the leads of a 20,000  $\Omega$  resistor from each of the capacitor leads to chassis ground.
3. Disconnect the wires from one of the terminals.
4. Set the ohmmeter to the R x 1K scale.
5. Touch the ohmmeter test leads to the capacitor terminals. The meter should indicate several ohms and gradually return to infinity.

### MAGNETRON

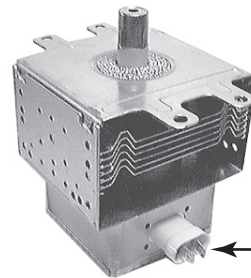

Filament Terminals

Refer to page 4-21 for the procedure for accessing the magnetron.

1. Unplug microwave oven or disconnect power.
2. Disconnect one of the wires from the magnetron filament terminals.
3. Set the ohmmeter to the R x 1 scale.
4. Touch the ohmmeter test leads to the filament terminals. The meter should indicate less than 1  $\Omega$ .
5. Touch one of the ohmmeter test leads to each of the filament terminals and the other lead to the chassis. The meter should indicate infinite resistance for both terminals.

# ⚠ WARNING



## Electrical Shock Hazard

Disconnect power before servicing.

Replace all parts and panels before operating.

Failure to do so can result in death or electrical shock.

## HIGH-VOLTAGE TRANSFORMER

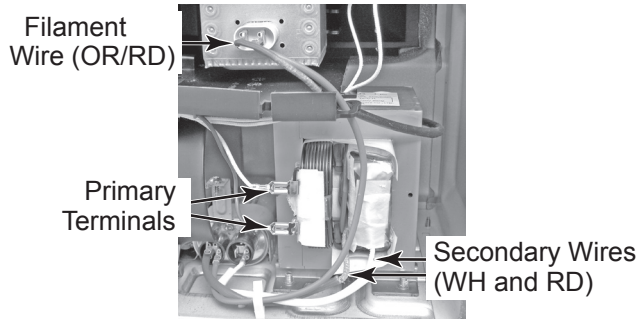

Refer to page 4-24 for the procedure for accessing the high-voltage (H.V.) transformer.

1. Unplug microwave oven or disconnect power.
2. Disconnect the wires from the H.V. transformer terminals.
3. Disconnect the H.V. transformer wires from the magnetron and the H.V. capacitor.
4. Set the ohmmeter to the R x 1 scale.
5. Touch the ohmmeter test leads to the following H.V. transformer locations:
  - Filament wire (org/red) to ground = Infinite.
  - Primary terminals (red & white) wires = less than 1  $\Omega$ .
  - Secondary (red & white) wires = 60  $\Omega$  (approximately).

## TURNTABLE MOTOR

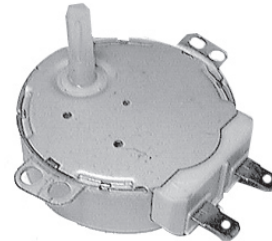

Refer to page 4-25 for the procedure for accessing the turntable motor.

1. Unplug microwave oven or disconnect power.
2. Disconnect one of the wires from the turntable motor terminals.
3. Set the ohmmeter to the R x 10K scale.
4. Touch the ohmmeter test leads to the motor terminals. The meter should indicate between 2700 and 3800  $\Omega$ .



# DIAGNOSTICS AND TROUBLESHOOTING

## PRIMARY, SECONDARY, AND MONITOR INTERLOCK SWITCH CHECKOUT PROCEDURE

Switch	Check By	Door Open	Door Closed
Primary Interlock	1. Unplug microwave oven or disconnect power. 2. Disconnect the wires at the Primary Interlock Switch. 3. Check from the common terminal (black wire) to the normally open terminal (brown/white wires).	-	+
	1. Unplug microwave oven or disconnect power. 2. Disconnect the wires at the Primary Interlock Switch. 3. Check from the common terminal (black wire) to the normally closed terminal (orange wire).	+	-
Secondary Interlock	1. Unplug microwave oven or disconnect power. 2. Disconnect the wires at the Secondary Interlock Switch. 3. Check from the common terminal (blue/black wires) to the normally open terminal (white/blue wires).	-	+
Monitor Interlock	1. Unplug microwave oven or disconnect power. 2. Disconnect the wires at the Monitor Interlock Switch. 3. Check from the common terminal (white wire) to the normally closed terminal (red wire).	+	-

(+) Continuity (-) No Continuity

**NOTE:** These diagrams are not intended to show a complete circuit; they represent the position of switches during "DOOR OPEN" or "DOOR CLOSED" (continuity checks only).

Door Closed

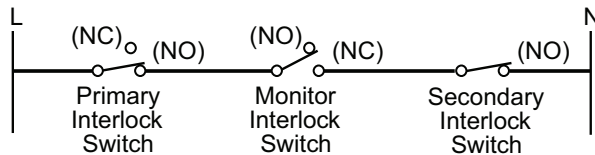

Door Open

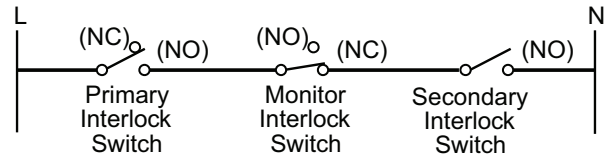

## FAILURE CODE INDICATIONS

**NOTE:** Many of the problems listed in the chart below may be solved by power cycling: unplug microwave oven or disconnect power.

After one minute, plug in microwave oven or reconnect power.

Display	Likely Failure Condition	Recommended Repair Procedure
Flashing colon “:.”	Power failure	After a power failure, the colon “:.” will be flashing. Press any key to end this indication. The colon will then be steady when in standby.
F2	Touch panel failure	<ol style="list-style-type: none"> <li>1. Unplug microwave oven or disconnect power.</li> <li>2. Replace touch panel.</li> <li>3. Replace all parts and panels before operating.</li> <li>4. Plug in microwave oven or disconnect power.</li> <li>5. If problem persists, unplug microwave oven or disconnect power.</li> <li>6. Replace electronic control.</li> <li>7. Replace all parts and panels before operating.</li> <li>8. Plug in microwave oven or reconnect power.</li> </ol>
F3H	Humidity sensor failure	<ol style="list-style-type: none"> <li>1. Unplug microwave oven or disconnect power.</li> <li>2. Connect a new humidity sensor to the electronic control (at P1).</li> <li>3. Replace all parts and panels before operating.</li> <li>4. Plug in microwave oven or reconnect power.</li> <li>5. If no failure code appears when starting sensor function, unplug microwave oven or disconnect power.</li> <li>6. Replace humidity sensor.</li> <li>7. Replace all parts and panels before operating.</li> <li>8. Plug in microwave oven or reconnect power.</li> <li>9. If failure code appears when starting sensor function, unplug microwave oven or disconnect power.</li> <li>10. Replace electronic control.</li> <li>11. Replace all parts and panels before operating.</li> <li>12. Plug in microwave oven or reconnect power.</li> </ol>
F6	MW relay	<ol style="list-style-type: none"> <li>1. Unplug microwave oven or disconnect power.</li> <li>2. Check wiring to Relay 4903.</li> <li>3. Check to see if the relay (4903 on relay control board) contact has welded closed.</li> <li>4. Replace all parts and panels before operating.</li> <li>5. Plug in microwave oven or reconnect power.</li> <li>6. If problem persists, unplug microwave oven or disconnect power.</li> <li>7. Replace electronic control.</li> <li>8. Replace all parts and panels before operating.</li> <li>9. Plug in microwave oven or reconnect power.</li> </ol>

## TOUCH PANEL AND ELECTRONIC CONTROL TEST

The microwave hood combination is provided with a self-diagnostic routine that can be accessed through the touch keypad.

### To initiate this routine:

1. Press and hold CANCEL/OFF while opening the door.
2. While still holding the CANCEL/OFF button, unplug the microwave oven for 2 seconds; then plug it back in.

3. Release the CANCEL/OFF button and close the door.
4. After pressing each button on the control panel, "8" will appear in the display to indicate that the circuits are complete and all relays are working. Refer to Key Table for Test Mode.

**NOTE:** If the CANCEL/OFF button is pressed during this diagnostic routine, you will exit the test mode.

## KEY TABLE FOR TEST MODE

**NOTE:** Display position "1" is farthest to the left. Display position "5" is farthest to the right.

Key Name	In Circuit Relay	Display Position*
Popcorn	-	1
Baked Potato	-	2
Meal Reheat	-	3
Reheat	-	4
Cook	Humidity Sensor	Sxxxx
Defrost	-	1
Cook Time	-	2
Cook Power	-	3
Keep Warm	-	4
1	Relay 4901	5/CL
2	Relay 4911	1/HL
3	Relay 4903	2/MW
4	-	3
5	-	4

\*"8" will appear in the display position indicated in the table.

\*After 8 seconds, Hmxxx will be displayed (xxx represents humidity reading).

Key Name	In Circuit Relay	Display Position*
6	Relay 4906 & Relay 4901	5/CL
7	-	1
8	Relay 4912	2
9	Hood Fan Triac— Relay 4902 & Relay 4905	3
Clock	Buzzer	4/Buzzer
0	-	5
Timer	-	1
Add a Minute	-	2
Start	-	4
Cancel/Off (to lock, hold for 5 seconds)	Exit Test Mode	-
Light On/Night/Off	-	1
Vent Fan 5 Speeds	-	2
Turntable On/Off	-	3

\*"8" will appear in the display position indicated in the table.

## **MICROWAVE OVEN POWER OUTPUT TEST**

1. Place 8 oz (250 mL) of lukewarm water in the center of the microwave oven.
2. Operate on HIGH power level for 2 minutes. Water should be hot.

**NOTE:** If the water takes longer than 2 minutes to heat, this may indicate either the operating voltage is lower than 110 volts or there is a problem with the microwave oven.

# WIRING DIAGRAM AND STRIP CIRCUITS

## WIRING DIAGRAM

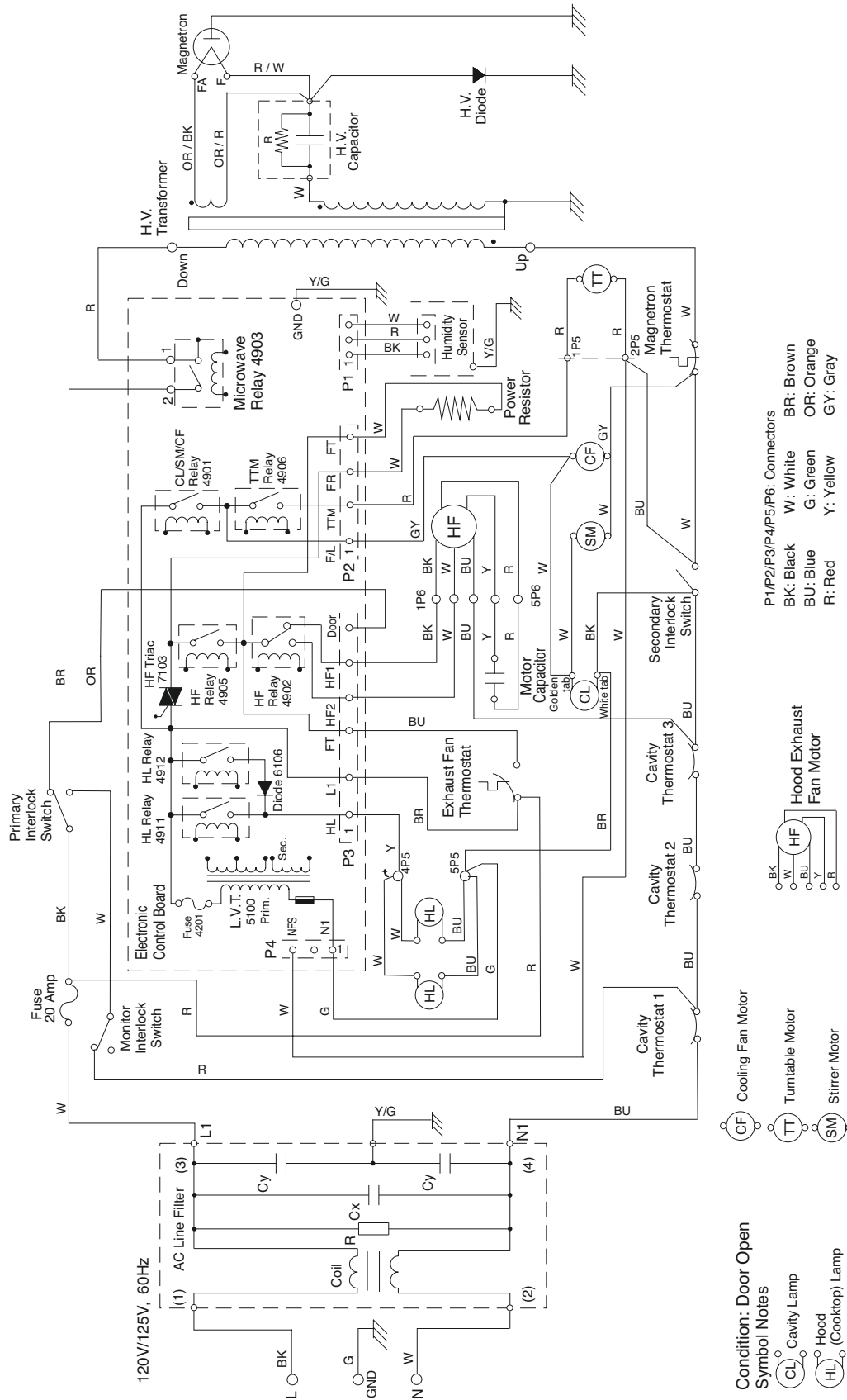

# STRIP CIRCUITS

## MICROWAVE COOKING

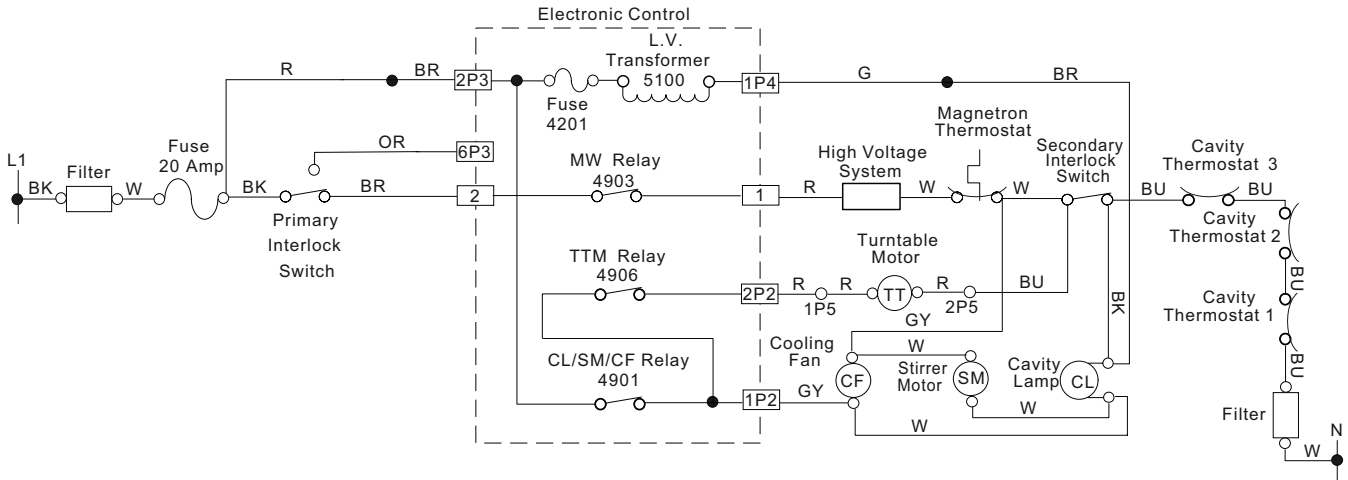

## HOOD EXHAUST FAN TURNS ON HIGH AUTOMATICALLY WHILE AT OFF OR SPEEDS 4 OR 3

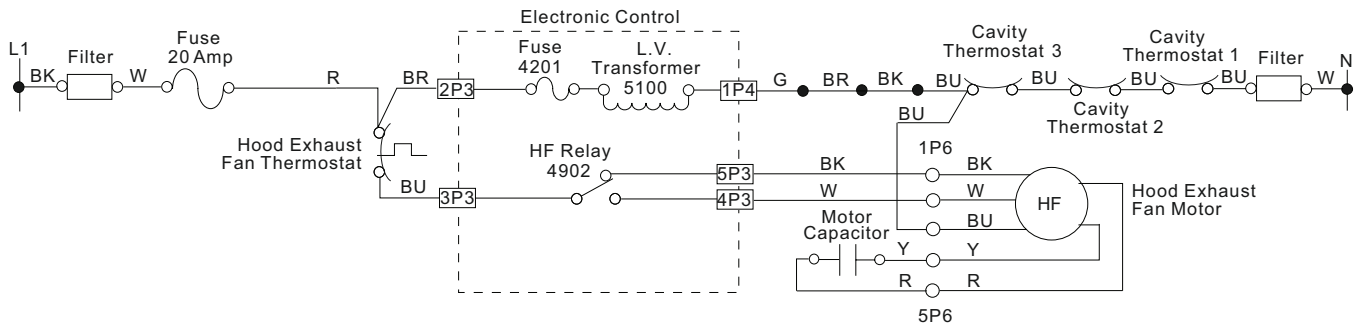

## HOOD EXHAUST FAN TURNS ON LOW AUTOMATICALLY WHILE AT SPEEDS 2 OR 1

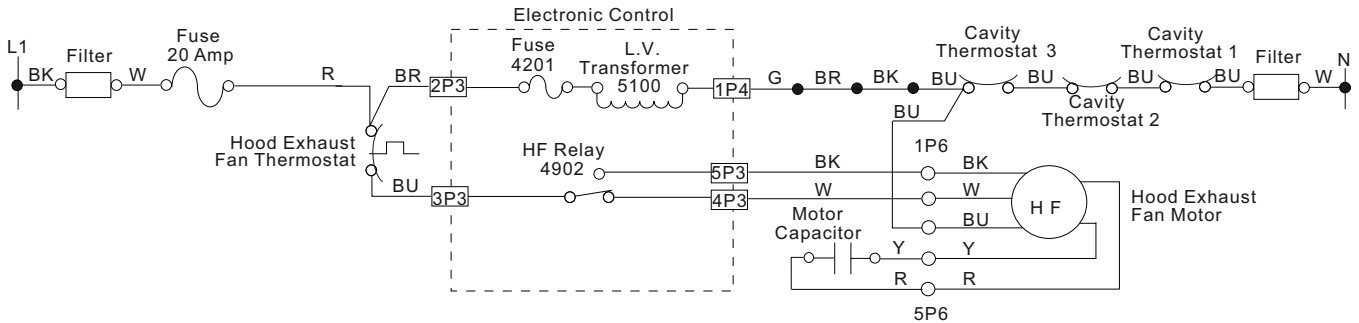

## HOOD EXHAUST FAN TURNS ON (SPEEDS 4 AND 3 MANUALLY)

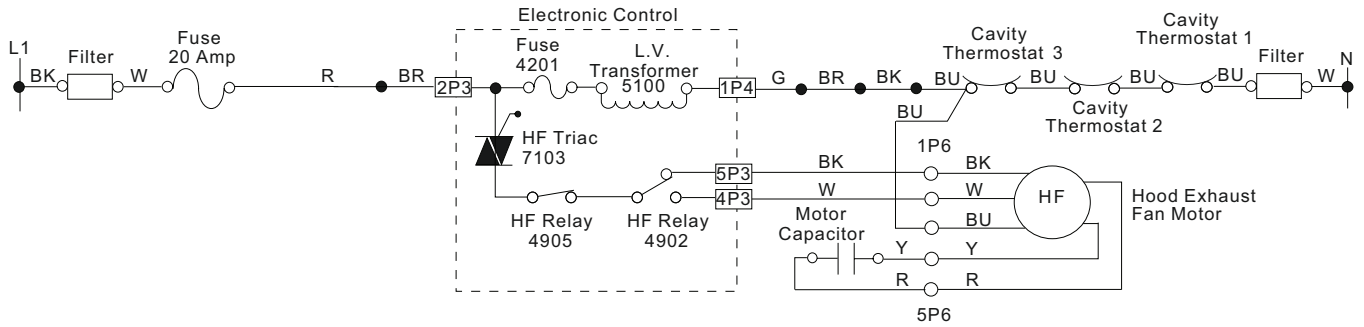

## HOOD EXHAUST FAN TURNS ON (SPEED 2 MANUALLY)

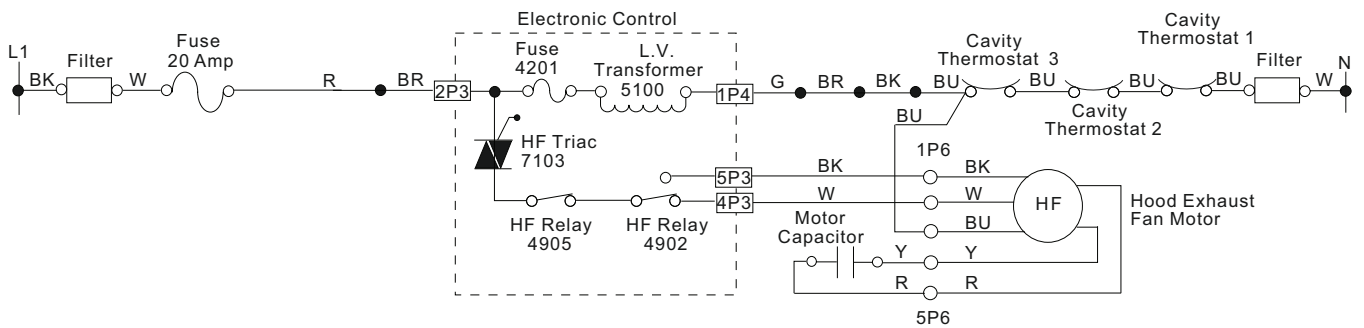

## HOOD EXHAUST FAN TURNS ON (SPEED 1 MANUALLY)

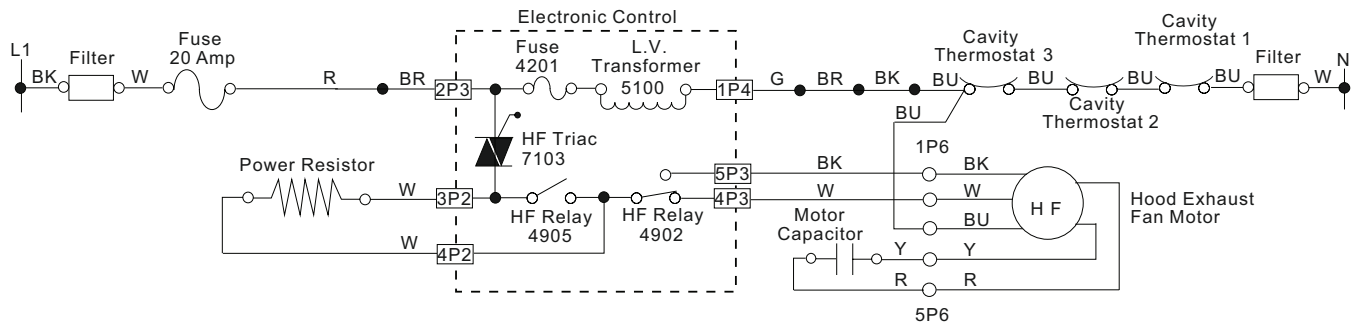

## MICROWAVE PLUGGED IN—TIME OF DAY DISPLAYED

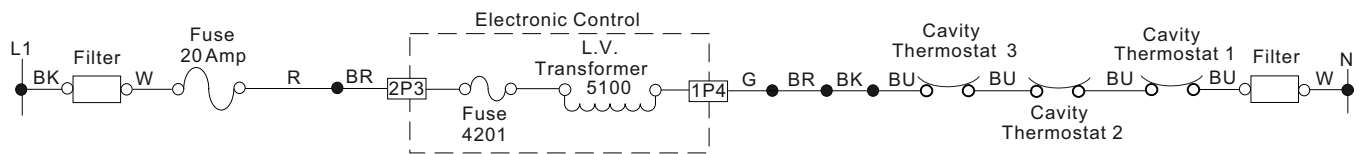

## DOOR OPEN—OVEN CAVITY LIGHT IS ON

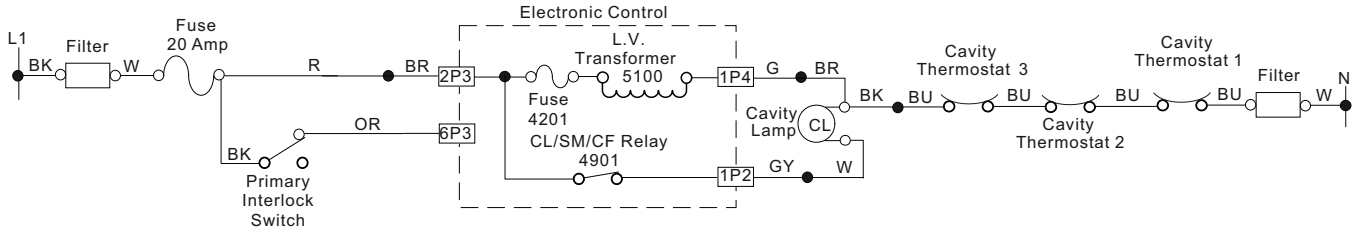

## COOKTOP LIGHT ON HIGH

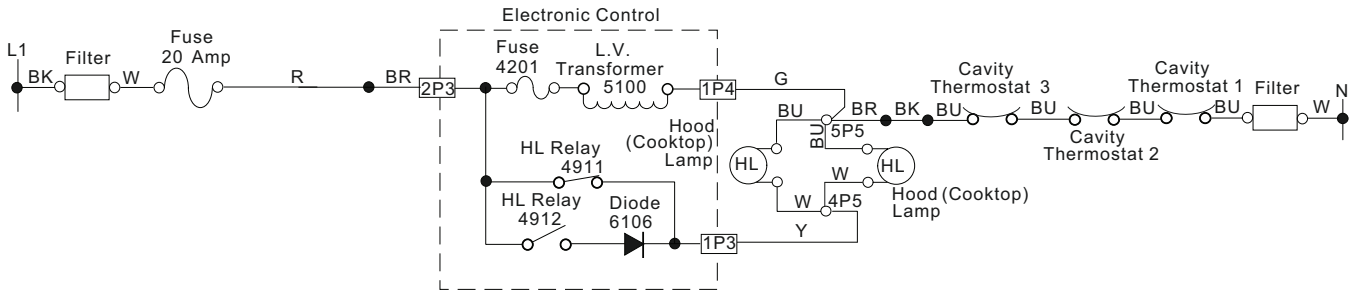

## COOKTOP LIGHT ON LOW (NIGHT LIGHT)

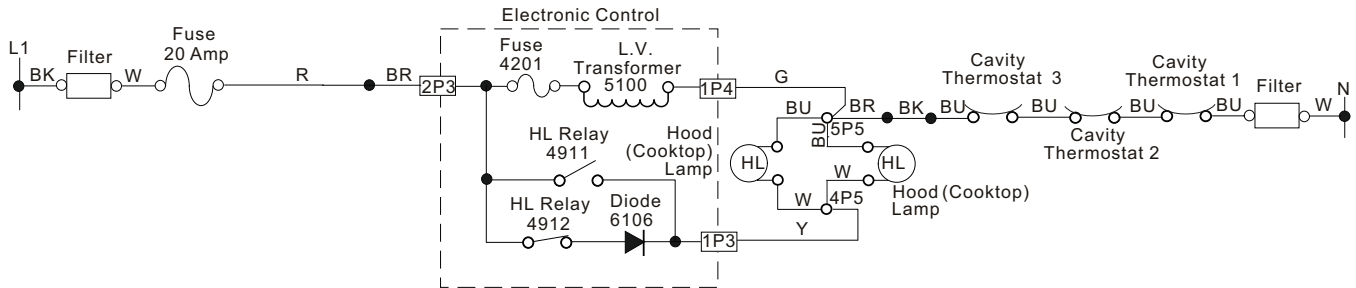



— NOTES —

— NOTES —

# **PRODUCT SPECIFICATIONS AND WARRANTY INFORMATION SOURCES**

## ***IN THE UNITED STATES:***

### **FOR PRODUCT SPECIFICATIONS AND WARRANTY INFORMATION, CALL:**

FOR WHIRLPOOL PRODUCTS: 1-800-253-1301  
FOR KITCHENAID PRODUCTS: 1-800-422-1230  
FOR ROPER PRODUCTS: 1-800-447-6737

### **FOR TECHNICAL ASSISTANCE WHILE AT THE CUSTOMER'S HOME, CALL:**

THE TECHNICAL ASSISTANCE LINE: 1-800-832-7174

**HAVE YOUR STORE NUMBER READY TO IDENTIFY YOU AS AN  
AUTHORIZED IN-HOME SERVICE PROFESSIONAL**

### **FOR LITERATURE ORDERS:**

PHONE: 1-800-851-4605

### **FOR TECHNICAL INFORMATION AND SERVICE POINTERS:**

[www.servicematters.com](http://www.servicematters.com)

---

## ***IN CANADA:***

### **FOR PRODUCT SPECIFICATIONS AND WARRANTY INFORMATION, CALL:**

1-800-461-5681

### **FOR TECHNICAL ASSISTANCE WHILE AT THE CUSTOMER'S HOME, CALL:**

THE TECHNICAL ASSISTANCE LINE: 1-800-488-4791

**HAVE YOUR STORE NUMBER READY TO IDENTIFY YOU AS AN  
AUTHORIZED IN-HOME SERVICE PROFESSIONAL**

**KitchenAid**<sup>®</sup>  
FOR THE WAY IT'S MADE.<sup>®</sup>

