

KitchenAid

TECHNICAL EDUCATION

OUTDOOR GAS GRILL



MODELS: KFRS271TSS, KFRS361TSS, KFRS365TSS, KFRU368TSS, KFRU488TSS, KBNS271TSS, KBSS271TSS, KBNS361TSS, KBSS361TSS, KBNU367TSS, KBSU367TSS, KBNU487TSS, KBSU487TSS

JOB AID 4317432

FORWARD

This KitchenAid Job Aid “Outdoor Gas Grill” (Part No. 4317432), provides the In-Home Service Professional with information on the installation, operation, and service of the Outdoor Gas Grill. For specific information on the model being serviced, refer to the “Use and Care Guide,” or “Tech Sheet” provided with the grill.

GOALS AND OBJECTIVES

The goal of this Job Aid is to provide information that will enable the In-Home Service Professional to properly diagnose malfunctions and repair the Outdoor Gas Grill.

The objectives of this Job Aid are to:

- Understand and follow proper safety precautions.
- Successfully troubleshoot and diagnose malfunctions.
- Successfully perform necessary repairs.
- Successfully return the grill to its proper operational status.

WHIRLPOOL CORPORATION assumes no responsibility for any repairs made on our products by anyone other than authorized In-Home Service Professionals.

TABLE OF CONTENTS

Page

GENERAL	1-1
Safety First	1-1
KitchenAid Model & Serial Number Designations	1-3
Model & Serial Number Label Locations	1-4
Specifications	1-5
INSTALLATION INFORMATION	2-1
Installation Requirements	2-1
Installation Instructions	2-10
PRODUCT OPERATION	3-1
Outdoor Grill Use	3-1
Using Your Outdoor Grill	3-2
COMPONENT ACCESS	4-1
Component Locations (Typical)	4-1
Removing the Control Panel and Spark Module	4-2
Removing the Infrared Rotisserie Burner Hot Surface or Spark Igniter & Thermocouple ..	4-4
Removing the Infrared Rotisserie Burner	4-7
Removing a Burner, Burner Ignitor, Infrared Gas Valve, and Burner Gas Valve	4-8
Removing the Battery (S Model Only)	4-11
Removing a Cabinet Door	4-12
Removing Transformer	4-13
Removing Grill Light and Light Switch	4-14
Removing Warming Drawer Assembly, Warming Drawer Control, Heating Element and Sensor	4-16
Removing a Side Burner and Side Burner Igniter	4-21
Removing a Sear Burner	4-22
Wiring Diagram	5-1
"S" Style Model Wiring Diagram	5-1
"U" Style Model Wiring Diagram	5-2
Warming Drawer Wiring Diagram	5-3

— NOTES —

GENERAL SAFETY FIRST

Your safety and the safety of others are very important.

We have provided many important safety messages in this manual and on the appliance. Always read and obey all safety messages.



This is the safety alert symbol.

This symbol alerts you to potential hazards that can kill or hurt you and others.

All safety messages will follow the safety alert symbol and either the word “DANGER” or “WARNING.” These words mean:

! DANGER

You can be killed or seriously injured if you don't immediately follow instructions.

! WARNING

You can be killed or seriously injured if you don't follow instructions.

All safety messages will tell you what the potential hazard is, tell you how to reduce the chance of injury, and tell you what can happen if the instructions are not followed.

! DANGER

If you smell gas:

1. Shut off gas to the appliance.
2. Extinguish any open flame.
3. Open lid.
4. If odor continues, keep away from the appliance and immediately call your gas supplier or your fire department.

! WARNING

1. Do not store or use gasoline or other flammable liquids or vapors in the vicinity of this or any other appliance.
2. An LP cylinder not connected for use shall not be stored in the vicinity of this or any other appliance.

The California Safe Drinking Water and Toxic Enforcement Act requires the Governor of California to publish a list of substances known to the State of California to cause cancer, birth defects, or other reproductive harm, and requires businesses to warn of potential exposure to such substances.

WARNING: This product contains a chemical known to the State of California to cause cancer, birth defects, or other reproductive harm.

This appliance can cause low-level exposure to some of the substances listed, including benzene, crystalline silica, carbon monoxide, toluene, and soot.

In the State of Massachusetts, the following installation instructions apply:

- Installations and repairs must be performed by a qualified or licensed contractor, plumber, or gasfitter qualified or licensed by the State of Massachusetts.
- If using a ball valve, it shall be a T-handle type.
- A flexible gas connector, when used, must not exceed 3 feet.

IMPORTANT: This grill is manufactured for outdoor use only. For grills that are to be used at elevations above 2000 ft (609.6 m) orifice conversion is required. See “Gas Supply Requirements” section. It is the responsibility of the installer to comply with the minimum installation clearances specified on the model/serial rating plate. The model/serial rating plate for freestanding models can be found on the right-hand inside cabinet wall. The model/serial rating plate for built-in models can be found on the right-hand side of the grill.

Copies of the standards listed may be obtained from:

National Fire Protection Association

One Batterymarch Park

Quincy, Massachusetts 02269

CSA International

8501 East Pleasant Valley Rd.

Cleveland, Ohio 44131-5575

KITCHENAID MODEL & SERIAL NUMBER DESIGNATIONS

MODEL NUMBER

MODEL NUMBER	K	BN	S	3	6	1	T	SS	0
PRODUCT GROUP K = KITCHENAID									
PRODUCT IDENTIFICATION BN = BUILT-IN OUTDOOR GRILL FR = FREESTANDING OUTDOOR GRILL									
MERCHANDISING SCHEME S = SUPERBA U = ULTIMA									
CAPACITY / SIZE / SERIES / CONFIGURATION 1ST POSITION 2 = 2 BURNERS / DIRECT COOKING 3 = 3 BURNERS / DIRECT & INDIRECT COOKING 4 = 4 BURNERS / DIRECT & INDIRECT COOKING 2ND POSITION 7 = 27" 6 = 36" 9 = 39" 8 = 48"									
FEATURES 0 = BASE MODEL 1 = FULL GRILLING SURFACE 2 = INTEGRATED ROTISSERIES, FULL GRILLING SURFACE & INTEGRATED SIDE BURNER 3 = INTEGRATED SIDE BURNER & FULL GRILLING SURFACE 4 = INTEGRATED ROTISSERIE & FULL GRILLING SURFACE 5 = SEAR IR & FULL GRILLING SURFACE 6 = INTEGRATED ROTISSERIE, SEAR IR & FULL GRILLING SURFACE									
YEAR OF INTRODUCTION T = 2007									
COLOR CODE SS = STAINLESS STEEL									
ENGINEERING CHANGE (0, 1, 2, ETC.)									

SERIAL NUMBER

SERIAL NUMBER	X	T	41	01002
DIVISION RESPONSIBILITY X = OXFORD				
YEAR OF PRODUCTION T = 2006 U = 2007				
WEEK OF PRODUCTION 41 = 41ST WEEK				
PRODUCT SEQUENCE NUMBER				

MODEL & SERIAL NUMBER LABEL LOCATION

The Model/Serial Number label locations are shown below.

On freestanding models, the model/serial number rating plate is located inside the grill cabinet on the right-hand cabinet side. See the following illustration.

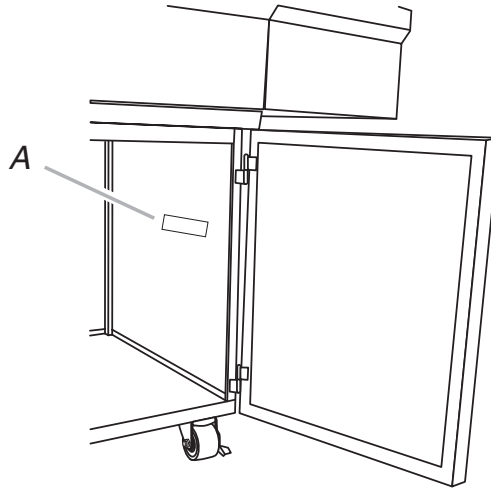

A. Model/serial number plate

On built-in models, the model/serial number rating plate is located on the right-hand side of the grill. See the following illustration.

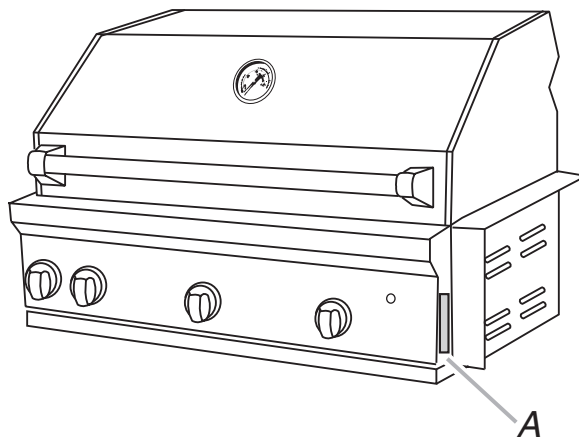

A. Model/serial number plate

SPECIFICATIONS

MODELS	KFRS271TSS	KFRS361TSS	KFRS365TSS
Existing Comparable Material Number	KFGR271SSS	KFGR361SSS	KFGR383SSS
Size-Configurations	Superba 27"	Superba 36"	Superba 36" +12" (Side Burner)
Platform	Freestanding	Freestanding	Freestanding
EXTERIOR			
Cooktop Controls	Push to turn with detentes	Push to turn with detentes	Push to turn with detentes
Storage Drawers	No	No	No
FEATURES			
Built In temperature gauge (with temperature in F degrees and indication of meat doneness)	YES, Hood Thermometer,	YES, Hood Thermometer,	YES, Hood Thermometer
Slide out Tank System	Robust Slide out Tank Tray with lock	Robust Slide out Tank Tray with lock	Robust Slide out Tank Tray with lock
Grill Grates	Stainless Steel / 3 piece grill rack	Stainless Steel / 3 piece grill rack	Stainless Steel / 3 piece grill rack
Sear IR	No	No	Yes - 23K BTU Sear infrared burner
Lighting	2 integrated halogen lights	2 integrated halogen lights	2 integrated halogen lights
Fuel conversion	Can be converted to natural gas and high altitudes.	Can be converted to natural gas and high altitudes.	Can be converted to natural gas and high altitudes.
Insulated Jacket	No	No	No
PERFORMANCE			
Ignition System	Burner control knob activated electronic ignition - Battery operated - Collector box with spark target.	Burner control knob activated electronic ignition - Battery operated - Collector box with spark target.	Burner control knob activated electronic ignition - Battery operated - Collector box with spark target.
Burners	2- 22.5 K BTU Stainless Steel U-shaped burners with a spider guard.	3- 22.5 K BTU Stainless Steel U-shaped burners with a spider guard.	2- 22.5 K BTU Stainless Steel U-shaped burners with a spider guard.
Infrared rotisserie back burner	SS -ceramic infrared burners- 15K BTU	SS -ceramic infrared burners- 15K	SS -ceramic infrared burners- 15K BTU
Heavy Duty Rotisserie with transformer	Sold as an accessory	Sold as an accessory	Sold as an accessory
Transformer	One	One	One
Drop - In Smoker	Sold as an accessory	Sold as an accessory	Sold as an accessory
Side burners	No	No	One 15K BTU side burners with SS grate-
Warming Drawer	No	No	No
Stainless steel side burner cover	No	No	Yes
Dimensions/Specifications			
Exterior Dimensions (grill opening)	27	36	36
Overall Depth (in) front of the storage panel)	24	24	24
Overall Width (in)	61 1/2	70 1/2	70 1/2
Overall Height (in) (w. hood down)	49	49	49
Cutout Dimensions			
Weight			
Net Weight (lbs)	264	345	378
MISCELLANEOUS			
Warranty	Yes	Yes	Yes
Full Limited	1 year	1 year	1 year
Limited	5 years	5 years	5 years
Stainless steel burners	Limited Lifetime	Limited Lifetime	Limited Lifetime
Liquid Propane , Natural Gas	LP (convertible)	LP (convertible)	LP (convertible)
LP tank	No	No	No
Insulation Jacket included for combustible enclosure installations	No	No	No
Product Literature			
Installation Instructions	W10110725	W10110725	W10110725
Use & Care Guide	Yes (bi-lingual)	Yes (bi-lingual)	Yes (bi-lingual)

MODELS	KFRU368TSS	KFRU488TSS	KBNS271TSS
Existing Comparable Material Number	New	New	KBGN274SSS
Size-Configurations	Ultima 36"	Ultima 48"	Superba Built-In 27"
Platform	Freestanding	Freestanding	Built-In
EXTERIOR			
Cooktop Controls	Push to turn with detentes	Push to turn with detentes	Push to turn with detentes
Storage Drawers	1 KA Commercial Design Double Wall Drawer , - KA Commercial design handles	KA Commercial Design Double Wall Drawer , - KA Commercial design handles	N/A
FEATURES			
Built In temperature gauge (with temperature in F degrees and indication of meat doneness)	YES, Hood Thermometer	YES, Hood Thermometer	YES, Hood Thermometer
Slide out Tank System	Robust Slide out Tank Drawer	Robust Slide out Tank Drawer	N/A
Grill Grates	Stainless Steel / 3 piece grill rack with Smoker Box.	Stainless Steel / 4 piece grill rack with Smoker Box.	Stainless Steel / 3 piece grill rack Grates are 9.5 mm thick
Sear IR	Yes - 23K BTU Sear infrared burner	Yes - 23K BTU Sear infrared burner	No
Lighting	2 halogen lights	2 halogen lights	2 integrated halogen lights
Fuel conversion	Can be converted to natural gas and high altitudes.	Can be converted to natural gas and high altitudes.	Can be converted to liquid propane and high altitudes.
Insulated Jacket	No	No	No
PERFORMANCE			
Ignition System	Knob Activated - Hot Surface Ignition	Knob Activated - Hot Surface Ignition	Burner control knob activated electronic ignition - Battery operated - Collector box with spark target.
Burners	2- 22.5 K BTU Stainless Steel U-shaped burners with a spider guard.	3- 22.5 K BTU Stainless Steel U-shaped burners with a spider guard.	2- 22.5 K BTU Stainless Steel U-shaped burners with a spider guard.
Infrared rotisserie back burner	SS -ceramic infrared burners- 15K BTU	2 - SS -ceramic infrared burners- 10K	SS -ceramic infrared burners- 15K
Heavy Duty Rotisserie with transformer	Yes	Yes	Sold as an accessory
Transformer	Two	Two	One
Drop - In Smoker	Yes	Yes	Sold as an accessory
Side burners	Two 15K BTU side burners with black porcelainized, mat finish cast iron grate	Two 15K BTU side burners with black porcelainized, mat finish cast iron grate	No
Warming Drawer	Yes	Yes	No
Stainless steel side burner cover	Yes	Yes	No
Dimensions/Specifications			
Exterior Dimensions (grill opening)	36	48	27
Overall Depth (in) front of the storage panel)	24	24	24
Overall Width (in)	84 1/2	96 1/2	31 3/4
Overall Height (in) (w. hood down)	50	50	23 3/4
Cutout Dimensions			
Weight			
Net Weight (lbs)	564	582	148
MISCELLANEOUS			
Warranty	Yes	Yes	Yes
Full Limited	1 year	1 year	1 year
Limited	5 years	5 years	5 years
Stainless steel burners	Limited Lifetime	Limited Lifetime	Limited Lifetime
Liquid Propane , Natural Gas	LP (convertible)	LP (convertible)	NG (Convertible)
LP tank	No	No	No
Insulation Jacket included for combustible enclosure installations	No	No	No
Product Literature			
Installation Instructions	W10110725	W10110725	W10110725
Use & Care Guide	Yes (bi-lingual)	Yes (bi-lingual)	Yes (bi-lingual)

MODELS	KBSS271TSS	KBNS361TSS	KBSS361TSS
Existing Comparable Material Number	KBGS274SSS	KBGN364SSS	KBGS364SSS
Size-Configurations	Superba Built-In 27" w/Jacket	Superba Built-In 36"	Superba Built-In 36" w/Jacket
Platform	Built-In	Built-In	Built-In
EXTERIOR			
Cooktop Controls	Push to turn with detentes	Push to turn with detentes	Push to turn with detentes
Storage Drawers	N/A	N/A	N/A
FEATURES			
Built In temperature gauge (with temperature in F degrees and indication of meat doneness)	YES, Hood Thermometer	YES, Hood Thermometer	YES, Hood Thermometer
Slide out Tank System	N/A	N/A	N/A
Grill Grates	Stainless Steel / 3 piece grill rack Grates are 9.5 mm thick	Stainless Steel / 3 piece grill rack Grates are 9.5 mm thick	Stainless Steel / 3 piece grill rack Grates are 9.5 mm thick
Sear IR	No	No	No
Lighting	2 integrated halogen lights	2 integrated halogen lights	2 integrated halogen lights
Fuel conversion	Can be converted to liquid propane and high altitudes.	Can be converted to liquid propane and high altitudes.	Can be converted to liquid propane and high altitudes.
Insulated Jacket	Yes	No	Yes
PERFORMANCE			
Ignition System	Burner control knob activated electronic ignition - Battery operated - Collector box with spark target.	Burner control knob activated electronic ignition - Battery operated - Collector box with spark target.	Burner control knob activated electronic ignition - Battery operated - Collector box with spark target.
Burners	2- 22.5 K BTU Stainless Steel U-shaped burners with a spider guard.	3- 22.5 K BTU Stainless Steel U-shaped burners with a spider guard.	3- 22.5 K BTU Stainless Steel U-shaped burners with a spider guard.
Infrared rotisserie back burner	SS -ceramic infrared burners- 15K	SS -ceramic infrared burners- 15K	SS -ceramic infrared burners- 15K
Heavy Duty Rotisserie with transformer	Sold as an accessory	Sold as an accessory	Sold as an accessory
Transformer	One	One	One
Drop - In Smoker	Sold as an accessory	Sold as an accessory	Sold as an accessory
Side burners	No	No	No
Warming Drawer	No	No	No
Stainless steel side burner cover	No	No	No
Dimensions/Specifications			
Exterior Dimensions (grill opening)	27	36	36
Overall Depth (in) front of the storage panel)	24	24	24
Overall Width (in)	32 3/4	40 3/4	41 3/4
Overall Height (in) (w. hood down)	25 1/2	23 3/4	25 5/9
Cutout Dimensions			
Weight			
Net Weight (lbs)	189	183	237
MISCELLANEOUS			
Warranty	Yes	Yes	Yes
Full Limited	1 year	1 year	1 year
Limited	5 years	5 years	5 years
Stainless steel burners	Limited Lifetime	Limited Lifetime	Limited Lifetime
Liquid Propane , Natural Gas	NG (Convertible)	NG (Convertible)	NG (Convertible)
LP tank	No	No	No
Insulation Jacket included for combustible enclosure installations	No	No	No
Product Literature			
Installation Instructions	W10110725	W10110725	W10110725
Use & Care Guide	Yes (bi-lingual)	Yes (bi-lingual)	Yes (bi-lingual)

MODELS	KBNS361TSS	KBSS361TSS	KBNU367TSS
Existing Comparable Material Number	KBGN364SSS	KBGS364SSS	New
Size-Configurations	Superba Built-In 36"	Superba Built-In 36" w/Jacket	Ultima Built-In 36"
Platform	Built-In	Built-In	Built-In
EXTERIOR			
Cooktop Controls	Push to turn with detentes	Push to turn with detentes	Push to turn with detentes
Storage Drawers	N/A	N/A	N/A
FEATURES			
Built In temperature gauge (with temperature in F degrees and indication of meat doneness)	YES, Hood Thermometer	YES, Hood Thermometer	YES, Hood Thermometer
Slide out Tank System	N/A	N/A	N/A
Grill Grates	Stainless Steel / 3 piece grill rack Grates are 9.5 mm thick	Stainless Steel / 3 piece grill rack Grates are 9.5 mm thick	Stainless Steel / 3 piece grill rack with Smoker Box.
Sear IR	No	No	Yes - 23K BTU Sear infrared burner
Lighting	2 integrated halogen lights	2 integrated halogen lights	2 halogen lights
Fuel conversion	Can be converted to liquid propane and high altitudes.	Can be converted to liquid propane and high altitudes.	Can be converted to liquid propane and high altitudes.
Insulated Jacket	No	Yes	
PERFORMANCE			
Ignition System	Burner control knob activated electronic ignition - Battery operated - Collector box with spark target.	Burner control knob activated electronic ignition - Battery operated - Collector box with spark target.	Knob Activated - Hot Surface Ignition
Burners	3- 22.5 K BTU Stainless Steel U-shaped burners with a spider guard.	3- 22.5 K BTU Stainless Steel U-shaped burners with a spider guard.	2- 22.5 K BTU Stainless Steel U-shaped burners with a spider guard.
Infrared rotisserie back burner	SS -ceramic infrared burners- 15K	SS -ceramic infrared burners- 15K	SS -ceramic infrared burners- 15K
Heavy Duty Rotisserie with transformer	Sold as an accessory	Sold as an accessory	Yes
Transformer	One	One	Two
Drop - In Smoker	Sold as an accessory	Sold as an accessory	Yes
Side burners	No	No	No
Warming Drawer	No	No	Yes
Stainless steel side burner cover	No	No	No
Dimensions/Specifications			
Exterior Dimensions (grill opening)	36	36	36
Overall Depth (in) front of the storage panel)	24	24	24
Overall Width (in)	40 3/4	41 3/4	40 3/4
Overall Height (in) (w. hood down)	23 3/4	25 5/9	23 3/4
Cutout Dimensions			
Weight			
Net Weight (lbs)	183	237	207
MISCELLANEOUS			
Warranty	Yes	Yes	Yes
Full Limited	1 year	1 year	1 year
Limited	5 years	5 years	5 years
Stainless steel burners	Limited Lifetime	Limited Lifetime	Limited Lifetime
Liquid Propane , Natural Gas	NG (Convertible)	NG (Convertible)	NG (Convertible)
LP tank	No	No	No
Insulation Jacket included for combustible enclosure installations	No	No	Yes - Cutout changes
Product Literature			
Installation Instructions	W10110725	W10110725	W10110725
Use & Care Guide	Yes (bi-lingual)	Yes (bi-lingual)	Yes (bi-lingual)

MODELS	KBSU367TSS	KBNU487TSS	KBSU487TSS
Existing Comparable Material Number	New	New	New
Size-Configurations	Ultima Built-In 36" w/Jacket	Ultima Built-In 48"	Ultima Built-In 48" w/Jacket
Platform	Built-In	Built-In	Built-In
EXTERIOR			
Cooktop Controls	Push to turn with detentes	Push to turn with detentes	Push to turn with detentes
Storage Drawers	N/A	N/A	N/A
FEATURES			
Built In temperature gauge (with temperature in F degrees and indication of meat doneness)	YES, Hood Thermometer	YES, Hood Thermometer	YES, Hood Thermometer
Slide out Tank System	N/A	N/A	N/A
Grill Grates	Stainless Steel / 3 piece grill rack with Smoker Box.	Stainless Steel / 4 piece grill rack with Smoker Box.	Stainless Steel / 4 piece grill rack with Smoker Box.
Sear IR	Yes - 23K BTU Sear infrared burner	Yes - 23K BTU Sear infrared burner	Yes - 23K BTU Sear infrared burner
Lighting	Lightning System with 2 halogen lights locate on the inside of the grill in the upper corners	Lightning System with 2 halogen lights locate on the inside of the grill in the upper corners	Lightning System with 2 halogen lights locate on the inside of the grill in the upper corners
Fuel conversion	Can be converted to liquid propane and high altitudes.	Can be converted to liquid propane and high altitudes.	Can be converted to liquid propane and high altitudes.
Insulated Jacket			
PERFORMANCE			
Ignition System	Knob Activated - Hot Surface Ignition	Knob Activated - Hot Surface Ignition	Knob Activated - Hot Surface Ignition
Burners	2- 22.5 K BTU Stainless Steel U-shaped burners with a spider guard.	3- 22.5 K BTU Stainless Steel U-shaped burners with a spider guard.	3- 22.5 K BTU Stainless Steel U-shaped burners with a spiderguard.
Infrared rotisserie back burner	SS -ceramic infrared burners- 15K	2 - SS -ceramic infrared burners- 10K	2 - SS -ceramic infrared burners- 10K
Heavy Duty Rotisserie with transformer	Yes	Yes	Yes
Transformer	Two	Two	Two
Drop - In Smoker	Yes	Yes	Yes
Side burners	No	No	No
Warming Drawer	Yes	Yes	Yes
Stainless steel side burner cover	No	No	No
Dimensions/Specifications			
Exterior Dimensions (grill opening)	36	48	48
Overall Depth (in) front of the storage panel)	24	24	24
Overall Width (in)	41 3/4	52 3/4	53 3/4
Overall Height (in) (w. hood down)	25 5/9	23 3/4	25 5/9
Cutout Dimensions			
Weight			
Net Weight (lbs)	261	270	343
MISCELLANEOUS			
Warranty	Yes	Yes	Yes
Full Limited	1 year	1 year	1 year
Limited	5 years	5 years	5 years
Stainless steel burners	Limited Lifetime	Limited Lifetime	Limited Lifetime
Liquid Propane , Natural Gas	NG (Convertible)	NG (Convertible)	NG (Convertible)
LP tank	No	No	No
Insulation Jacket included for combustible enclosure installations	Yes - Cutout changes	Yes - Cutout changes	Yes - Cutout changes
Product Literature			
Installation Instructions	W10110725	W10110725	W10110725
Use & Care Guide	Yes (bi-lingual)	Yes (bi-lingual)	Yes (bi-lingual)

— NOTES —

INSTALLATION REQUIREMENTS

Tools and Parts

Style 1 - Freestanding Outdoor Grills

Gather the required tools and parts before starting installation. Read and follow the instructions provided with any tools listed here.

Tools Needed

- Tape measure
- Small, flat-blade screwdriver
- Flat-blade screwdriver
- #2 and #3 Phillips screwdriver
- Level
- Wrench or pliers
- Pipe wrench
- Scissors or cutting pliers (to remove tie-downs)
- Noncorrosive leak detection solution

Parts Supplied (s models only)

- Gas pressure regulator/hose assembly set for 11" WCP LP gas (attached to manifold).
- 1.5 volt "D" size alkaline battery

Parts Supplied (u models only)

- Gas pressure regulator/hose assembly set for 11" WCP LP gas (attached to manifold).
- Rotisserie motor mounting bracket
- Rotisserie motor
- Rotisserie forks
- Rotisserie spit
- Smoker box
- 2 warming drawer pans
- 1 single-prong plug/transformer assembly

Parts Needed

- 20 lb LP gas fuel tank

Style 2 - Built-In Outdoor Grills

Gather the required tools and parts before starting installation. Read and follow the instructions provided with any tools listed here.

Tools Needed

- Tape measure
- Small, flat-blade screwdriver
- Flat-blade screwdriver
- #2 and #3 Phillips screwdriver
- Level
- Wrench or pliers
- Pipe wrench
- Scissors or cutting pliers (to remove tie-downs)
- Noncorrosive leak detection solution

Parts Needed

- Gas line shutoff valve
- ½" male pipe thread nipple for connection to pressure regulator.
- LP gas-resistant pipe-joint compound
- CSA design-certified outdoor flexible stainless steel appliance connector [4-5 ft (1.2-1.5 m)] or rigid gas supply line as needed.

Parts Supplied (s models only)

- Convertible regulator set for 4" WCP Natural gas.
- Single-prong plug/transformer assembly
- 1.5 volt "D" size alkaline battery

Parts Supplied (u models only)

- Convertible regulator set for 4" WCP Natural gas.
- 2 Single-prong plug/transformer assemblies.
- Rotisserie motor mounting bracket

Location Requirements

! WARNING



Explosion Hazard

Do not store fuel tank in a garage or indoors.

Do not store grill with fuel tank in a garage or indoors.

Failure to follow these instructions can result in death, explosion, or fire.

! WARNING



Fire Hazard

Do not use grill near combustible materials.

Do not store combustible materials near grill.

Doing so can result in death or fire.

Select a location that provides minimum exposure to wind and traffic paths. The location should be away from strong draft areas.

Do not obstruct flow of combustion and ventilation air.

Clearance to combustible construction for built-in and freestanding outdoor grills:

- A minimum of 24" (58 cm) must be maintained between the grill hood, sides and back and any combustible construction.
- A 24" (58 cm) minimum clearance must also be maintained below the cooking surface and any combustible construction.

Rotisserie (u models only)

A 6" (15.2 cm) minimum clearance is needed for the rotisserie motor.

A grounded, 3-prong outlet located to the left of the grill is required. See "Electrical Requirements" section.

Rotisserie (accessory)(s models only)

If you equip your grill with a rotisserie, a 6" (15.2 cm) minimum clearance is needed for the rotisserie motor.

A grounded, 3-prong outlet located to the left of the grill is required. See "Electrical Requirements" section.

Product Dimensions

Style 1 - Freestanding Outdoor Grill (s models only)

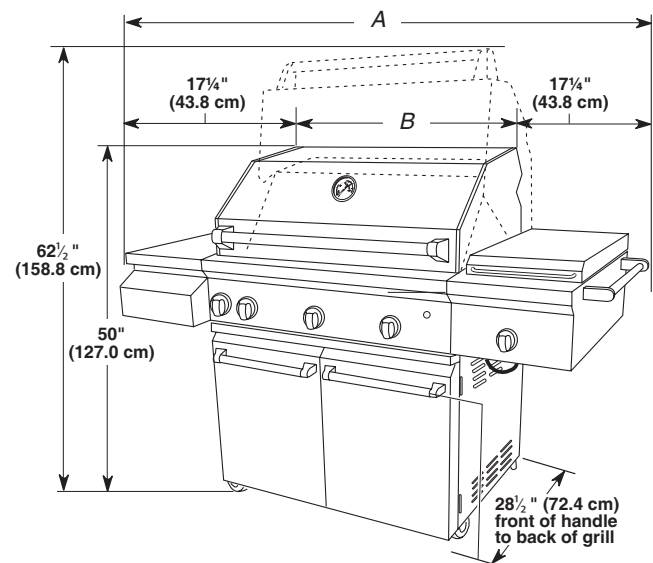

- A. 61 1/2" (156.2 cm) on 27" (68.6 cm) models
70 1/2" (179 cm) on 36" (91.4 cm) models
- B. 27" (68.6 cm)
36" (91.4 cm)

**Style 1 - Freestanding Outdoor Grill
(u models only)**

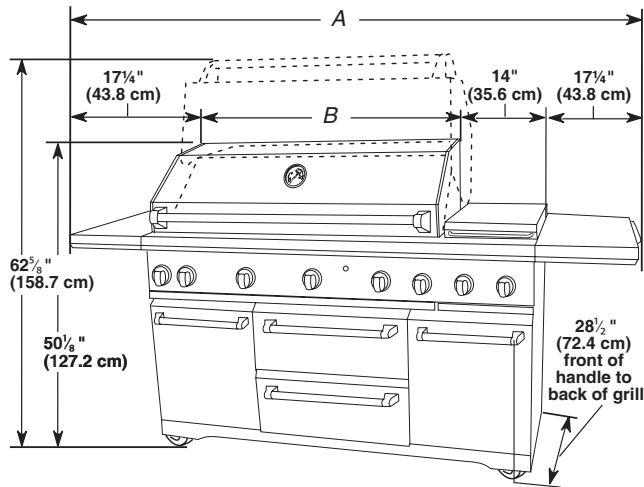

- A. 84 1/2" (214.6 cm) on 36" (91.4 cm) models
- 96 1/2" (245.1 cm) on 48" (121.9 cm) models
- B. 36" (91.4 cm)
- 48" (121.9 cm)

**Style 2 - Built-In Outdoor Grill
(u models only)**

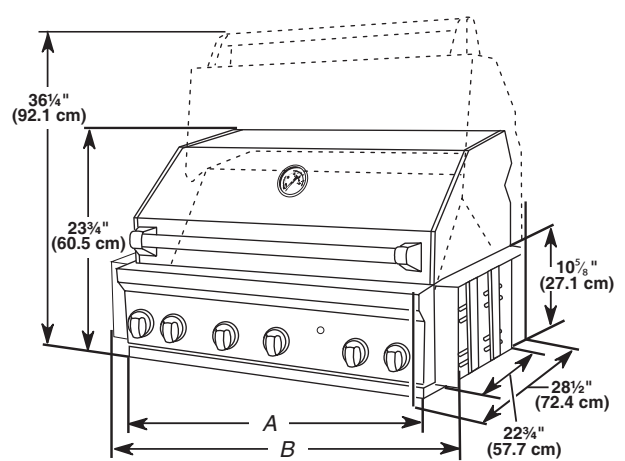

- A. 36" (91.4 cm)
- 48" (121.9 cm)
- B. 36" (91.4 cm) models - 40 3/4" (103.4 cm)
- 48" (121.9 cm) models - 52 3/4" (133.9 cm)

**Style 2 - Built-In Outdoor Grill
(s models only)**

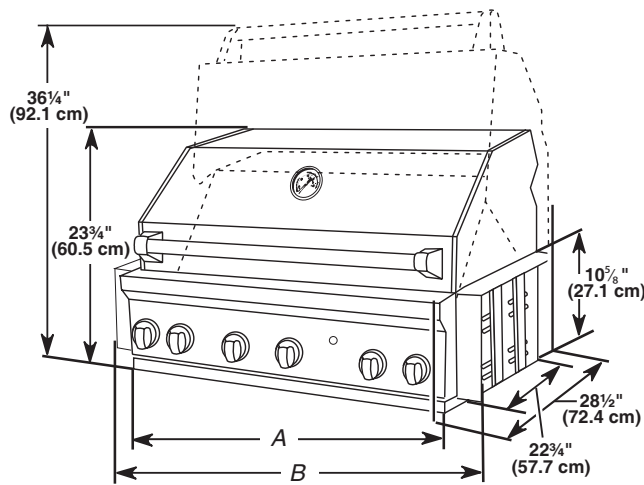

- A. 27" (68.6 cm)
- 36" (91.4 cm)
- B. 27" (68.6 cm) models - 31 3/4" (80.6 cm)
- 36" (91.4 cm) models - 40 3/4" (103.4 cm)

Built-In Outdoor Grill Enclosure

⚠ **WARNING**



Fire Hazard

Do not use grill near combustible materials.

Doing so can result in death or fire.

The enclosure for the built-in outdoor grill is to be a minimum of 11" (28.0 cm) high x 23" (58.4 cm) deep x [30" (76.0 cm) for 27" (68.6 cm) grill. [39" (99.0 cm) for 36" (91.4 cm) grill and 51" (129.5 cm) for 48" (121.9 cm) grill] wide. This built-in outdoor grill is only for installation in a built-in enclosure constructed only of non-combustible materials. Noncombustible materials could be brick, firewall or steel. Do not use wood or other combustible materials for built-in enclosure.

Electrical Requirements

⚠ WARNING



Electrical Shock Hazard

Plug into a grounded 3 prong outlet.

Do not remove ground prong.

Do not use an adapter.

Do not use an extension cord.

Failure to do so can result in death or electrical shock.

If codes permit and a separate ground wire is used, it is recommended that a qualified electrician determine that the ground path is adequate.

Check with a qualified electrician if you are not sure whether the grill is properly grounded.

A 120-volt, 60-Hz, AC-only, 15-amp, fused electrical supply is required.

It is recommended that a separate circuit servicing only this grill be provided.

On freestanding models, the model/serial number rating plate is located inside the grill cabinet on the right-hand cabinet side. See the following illustration.

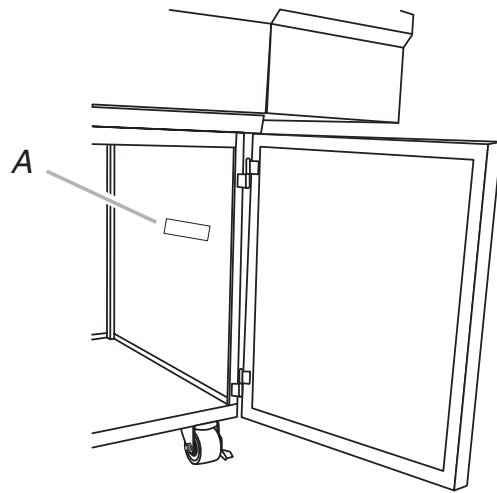

A. Model/serial number plate

On built-in models, the model/serial number rating plate is located on the right-hand side of the grill. See the following illustration.

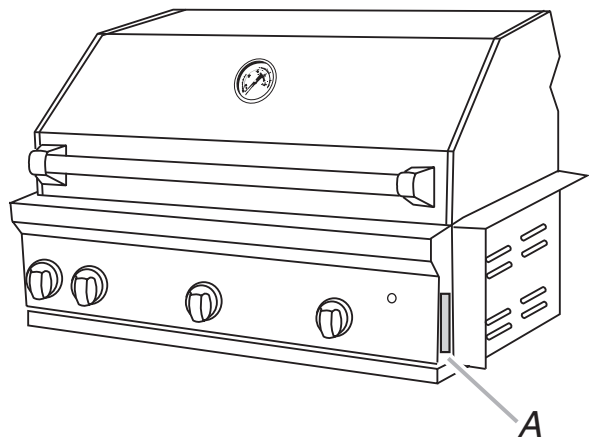

A. Model/serial number plate

Recommended Ground Method

The outdoor grill, when installed, must be electrically grounded in accordance with local codes or, in the absence of local codes, with the National Electrical Code ANSI/NFPA 70, or Canadian

Electrical Code, CSA C22.1.

Copies of the standards listed above may be obtained from:

CSA International
8501 East Pleasant Valley Rd.
Cleveland, Ohio 44131-5575
National Fire Protection Association
One Batterymarch Park
Quincy, Massachusetts 02269

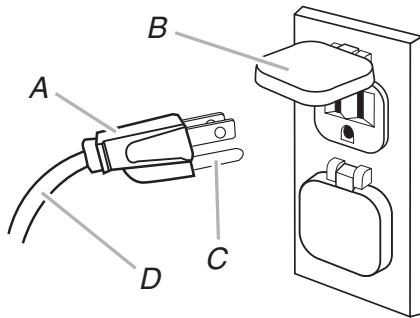

- A. 3-prong ground plug
- B. 3-prong polarized type outdoor outlet
- C. Ground prong
- D. Power supply cord

Gas Supply Requirements

! WARNING



Explosion Hazard

Use a new CSA International approved "outdoor" gas supply line.

Securely tighten all gas connections.

If connected to LP, have a qualified person make sure gas pressure does not exceed 11" (28 cm) water column.

Examples of a qualified person include:

**Licensed heating personnel,
authorized gas company personnel,
and authorized service personnel.**

Failure to do so can result in death, explosion, or fire.

Observe all governing codes and ordinances.

IMPORTANT: This installation must conform with all local codes and ordinances. In the absence of local codes, installation must conform with American National Standard, National Fuel Gas Code ANSI Z223.1 -latest edition or CAN/CGA B149.1 -latest edition.

IMPORTANT: Grill must be connected to a regulated gas supply.

Refer to the model/serial rating plate for information on the type of gas that can be used. If this information does not agree with the type of gas available, check with your local gas supplier.

Gas Conversion:

No attempt shall be made to convert the grill from the gas specified on the model/serial rating plate for use with a different gas type without consulting the serving gas supplier. The conversion kits specified must be used.

Gas Pressure Regulator

The gas pressure regulator supplied with this grill must be used. The inlet (supply) pressure to the regulator should be as follows for proper operation:

LP Gas:

Operating pressure: 11" (27.9 cm) WCP

Inlet (supply) pressure: 11" to 14" (27.9 cm to 35.5 cm) WCP

Natural Gas:

Operating pressure: 4" (10.2 cm) WCP Inlet (supply) pressure: 7" to 14" (17.8 cm to 35.5 cm) WCP maximum.

Contact local gas supplier if you are not sure about the inlet (supply) pressure.

Burner Requirements for High Altitude

Input ratings shown on the model//serial rating plate are for elevations up to 2,000 ft (609.6 m).

For elevations above 2,000 ft (609.6 m), ratings are reduced at a rate of 4% for each 1,000 ft (304.8 m) above sea level. Orifice conversion is required. See "Assistance or Service" section to order.

Gas Supply Line Pressure Testing Testing above ½ psi (3.5 kPa) or 14" (35.5 cm) WCP (gauge):

The grill and its individual shutoff valve must be disconnected from the gas supply piping system during any pressure testing of that system at test pressures greater than ½ psig (3.5 kPa).

Testing below ½ psi (3.5 kPa) or 14" (35.5 cm) WCP (gauge) or lower:

The grill must be isolated from the gas supply piping system by closing its individual manual shutoff valve during any pressure testing of the gas supply piping system at test pressures equal to or less than ½ psig (3.5 kPa).

Gas Connection Requirements Style 1 - Freestanding Outdoor Grills LP Gas Fuel Tank

This grill is equipped for use with a 20 lb LP gas fuel tank (fuel tank not supplied). A gas pressure regulator/hose assembly is supplied.

It is also design-certified by CSA International for local LP gas supply or for Natural gas with appropriate conversion.

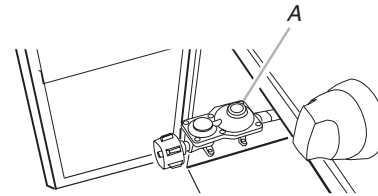

A. Gas pressure regulator/hose assembly

The 20 lb LP gas fuel tank must be mounted and secured.

(s models only)

1. Open cabinet doors.
2. Press the locking tab on the tank tray and pull out the tray.

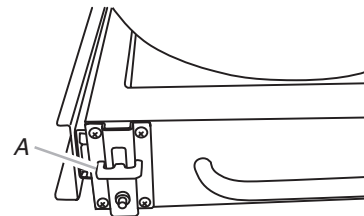

A. Tank tray locking tab

3. Place the 20 lb LP gas fuel tank bottom collar into the mounting hole in the tank tray.
4. Tighten the locking screw against the bottom collar of the 20 lb LP gas fuel tank to secure.

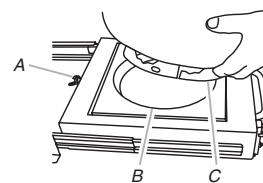

A. Locking screw
B. Mounting hole
C. Bottom collar

5. Slide tank tray back into the cabinet and lock into place.

(u models only)

1. Open the 20 lb LP gas fuel tank drawer.
2. Place the 20 lb LP gas fuel tank bottom collar into the mounting hole in the tank tray.
3. Tighten the locking screw against the bottom collar of the 20 lb LP gas fuel tank to secure.

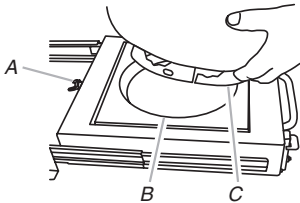

A. Locking screw
B. Mounting hole
C. Bottom collar

4. Slide tank drawer back into the cabinet.

Local LP Gas Supply

IMPORTANT: The gas installation must conform with local codes, or in the absence of local codes, with the National Fuel Gas Code, ANSI Z223.1/NFPA 54 - latest edition. The qualified LP gas technician shall provide the LP gas supply to the selected grill location in accordance with the National Fuel Gas Code, ANSI Z223.1/NFPA 54 and local codes.

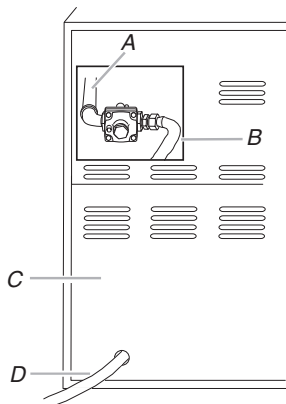

A. Grill gas pipe
B. New ANSI Z21.54 certified gray hose
C. Rear of grill
D. To local LP gas supply

Natural Gas Conversion

Conversion must be made by a qualified gas technician. The qualified Natural gas technician shall provide the Natural gas supply to the selected grill location in accordance with the National Fuel Gas Code ANSI Z223.1/NFPA 54 - latest edition, and local codes. For conversion to Natural gas, the Natural gas conversion kit must be used.

IMPORTANT: The gas installation must conform with local codes, or in the absence of local codes, with the National Fuel Gas Code, ANSI Z223.1/NFPA 54 - latest edition.

To convert to Natural gas, the Natural Gas Conversion Kit Part Number W10118098 must be used. Follow instructions included with the kit.

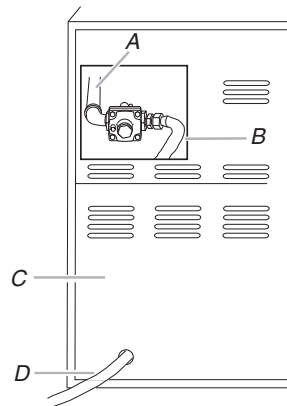

A. Grill gas pipe
B. New ANSI Z21.54 certified gray hose
C. Rear of grill
D. To Natural gas supply

Gas Connection Requirements Style 2 - Built-In Outdoor Grills

Natural Gas

Built-in grill models are equipped for use with Natural gas. They are design-certified by CSA International for LP (propane or butane) gases with appropriate conversion.

Built-in models are set for Natural gas use and have a pressure regulator with ½" female pipe threads.

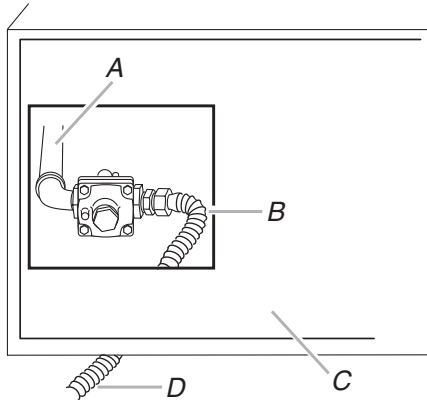

- A. Grill gas pipe
- B. New CSA International approved "outdoor" flexible gas supply line
- C. Rear of grill
- D. To Natural gas supply

The supply line shall be equipped with an approved shutoff valve. This valve should be located in the same area as the grill and should be in a location that allows ease of opening and closing. Do not block access to the shutoff valve. The valve is for turning on or shutting off gas to the grill.

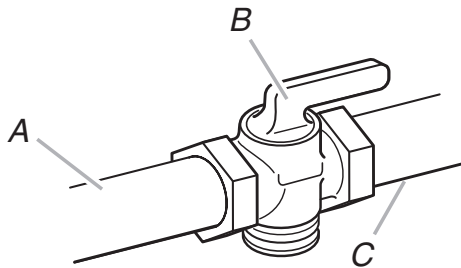

- A. Gas supply line
- B. Shutoff valve "open" position
- C. To grill

LP Gas Conversion Using a Local LP Gas Supply

Conversion must be made by a qualified person. A qualified Natural gas technician shall provide the LP gas supply to the selected grill location in accordance with the National Fuel Gas Code ANSI Z223.1/NFPA 54 - latest edition, and local codes.

To convert to LP gas, the LP Gas Conversion Kit Part Number W10118099 must be used. Follow instructions included with kit.

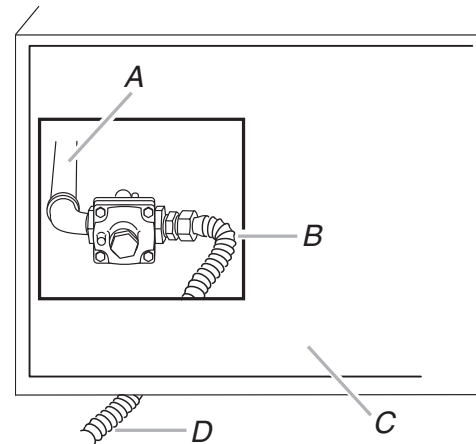

- A. Grill gas pipe
- B. New CSA International approved "outdoor" flexible gas supply line
- C. Rear of grill
- D. To local gas supply

LP Gas Conversion Using a 20 lb LP Gas Fuel Tank

To convert to LP gas, the LP Gas Conversion Kit Part Number W10118099 must be used. Follow instructions included with kit. A 20 lb LP gas fuel tank must be purchased separately.

INSTALLATION INSTRUCTIONS

Style 1 - Freestanding Outdoor Grill Installation

⚠ WARNING

Excessive Weight Hazard

Use two or more people to move and install grill.

Failure to do so can result in back or other injury.

1. Unpack grill. Remove all packaging materials and remove grill from wooden skid.
2. Move grill into desired outdoor location.
3. Open the hood.

Attach Side Shelf (on some models)

4. Open doors below grill and remove carton. Unpack side shelf.
5. Locate 4 screws. Install 2 screws in the top 2 holes on each side of the grill. Leave screws away from side of grill about 1/4" (0.64 cm).

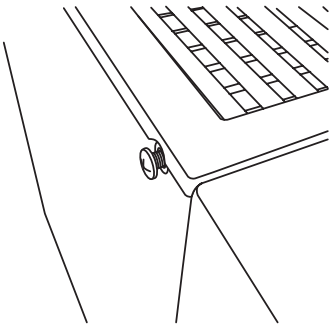

6. Install side shelf on left side of the grill. Position the side shelf so that the large end of the keyhole slots are over the screws. Place shelf onto the 2 mounting screws. Let the shelf slide down so the screws are in the narrow neck of the slots.

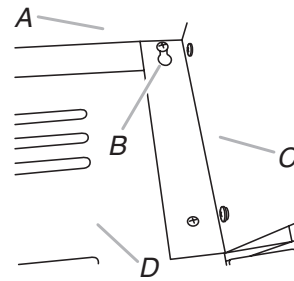

- A. Top of side shelf
- B. Keyhole slot
- C. Front of side shelf
- D. Side of grill

7. Install the bottom 2 screws and tighten.
8. Tighten the top 2 screws.

Attach Cabinet Doors (on some models)

1. Remove foam wrapping from both cabinet doors.
2. Position hinge pins on the door with the hinge brackets on the cabinet. Gently push down to slide the pins into place.

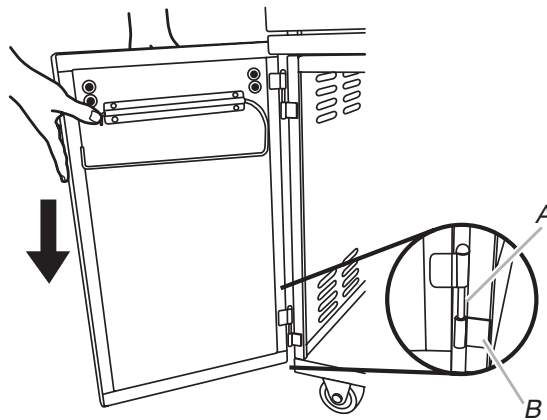

- A. Door hinge pin
- B. Hinge bracket

Remove Packaging Material Inside the Grill

1. Cut the tiedowns holding the grates together.
2. Remove condiment shelf, warming shelf and grill grates from inside the grill and remove packaging material.
3. Remove foam block and wrap from inside the grill.

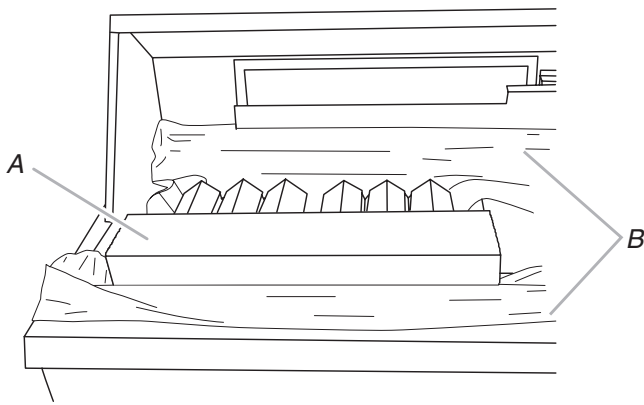

A. Foam block
B. Foam wrap

4. Replace the grill grates.
5. Place warming shelf on brackets as shown.

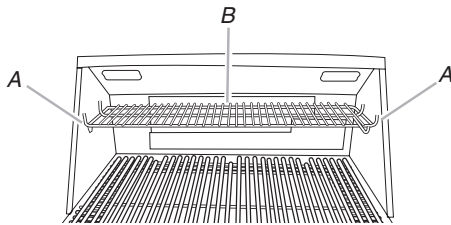

A. Warming shelf brackets
B. Warming shelf

6. Attach condiment shelf to the inside of the left cabinet door.

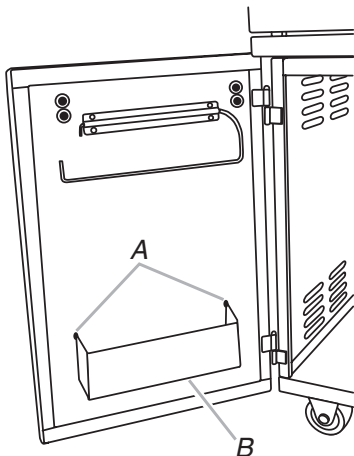

A. Attachment holes
B. Condiment shelf

7. Dispose of/recycle all packaging material.

Make Gas Connection

! WARNING



Explosion Hazard

Securely tighten all gas connections.

If connected to LP, have a qualified person make sure gas pressure does not exceed 11" (28 cm) water column.

Examples of a qualified person include:

**Licensed heating personnel,
authorized gas company personnel,
and authorized service personnel.**

Failure to do so can result in death, explosion, or fire.

If converting to Natural gas, see conversion kit requirements in the "Gas Supply Requirements" section. Follow instructions included with kit.

LP Gas:

IMPORTANT: A 20 lb LP gas fuel tank must be purchased separately.

IMPORTANT: The gas pressure regulator/hose assembly supplied with the grill must be used. Replacement gas pressure regulator/hose assembly specific to your model, is available from your outdoor grill dealer

To Install the 20 lb LP Gas Fuel Tank:

(s models only)

1. Open cabinet doors.
2. Press the locking tab on the tank tray and pull out the tray.

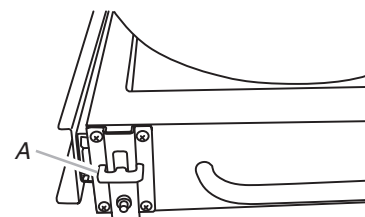

A. Tank tray locking tab

- Place the 20 lb LP gas fuel tank bottom collar into the mounting hole in the tank tray.
- Tighten the locking screw against the bottom collar of the 20 lb LP gas fuel tank to secure.

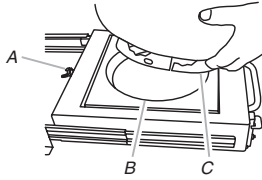

A. Locking screw
B. Mounting hole
C. Bottom collar

- Screw the gas pressure regulator/hose assembly to the 20 lb LP gas fuel tank as shown.

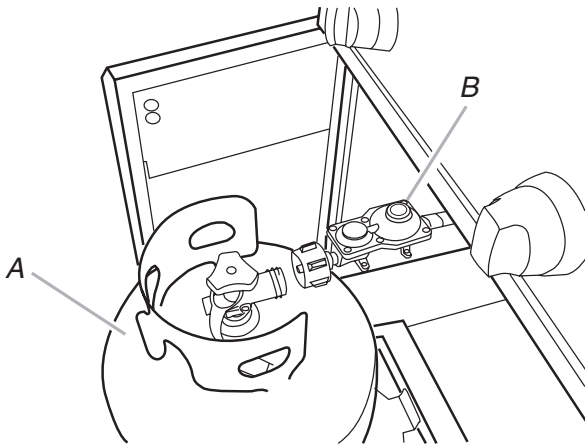

A. 20 lb LP gas fuel tank
B. Gas pressure regulator/hose assembly

- Turn on the gas supply. Wait a few minutes for gas to move through the gas line.
- Test all connections by brushing on an approved noncorrosive leak-detection solution. Bubbles will show a leak. Correct any leak found.
- Slide tank tray back into the cabinet and lock into place.
- The igniter battery is not factory installed. A 1.5 volt "D" size alkaline battery is located in the accessory box on the grill grate. Install battery at this time following the instructions in the "Replacing the Igniter Battery" section.
- Go to "Check and Adjust the Burners" section.

(u models only)

- Open the 20 lb LP gas fuel tank drawer.
- Place the 20 lb LP gas fuel tank bottom collar into the mounting hole in the tank tray.
- Tighten the locking screw against the bottom collar of the 20 lb LP gas fuel tank to secure.

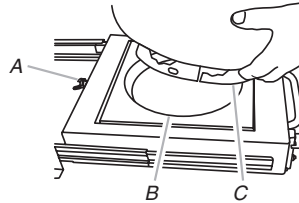

A. Locking screw
B. Mounting hole
C. Bottom collar

- Slide tank drawer back into the cabinet.
- Screw the gas pressure regulator/hose assembly to the 20 lb LP gas fuel tank as shown.

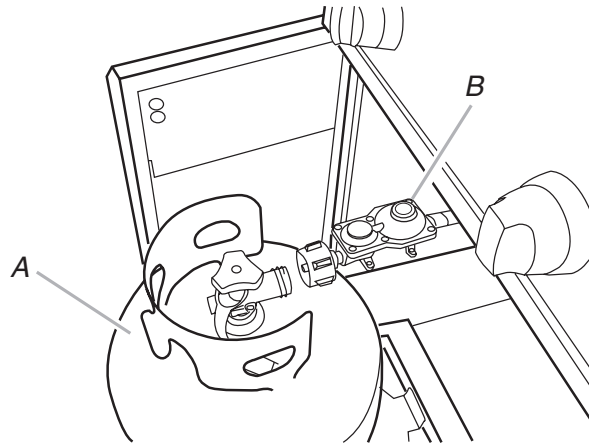

A. 20 lb LP gas fuel tank
B. Gas pressure regulator/hose assembly

- Turn on the gas supply. Wait a few minutes for gas to move through the gas line.
- Test all connections by brushing on an approved noncorrosive leak-detection solution. Bubbles will show a leak. Correct any leak found.
- Go to "Check and Adjust the Burners" section.

If Converted to Natural Gas

⚠ WARNING



Explosion Hazard

Use a new CSA International approved “outdoor” gas supply line.

Securely tighten all gas connections.

Failure to do so can result in death, explosion, or fire.

This installation must conform with local codes and ordinances.

In the absence of local codes, installations must conform with either the National Fuel Gas Code ANSI Z223.1, or CAN/CGAB149.1 Natural Gas and Propane installation code.

Copies of the standards listed above may be obtained from:

CSA International
8501 East Pleasant Valley Rd.
Cleveland, Ohio 44131-5575

National Fire Protection Association
One Batterymarch Park
Quincy, Massachusetts 02269

1. Make gas connections.

A combination of pipe fittings must be used to connect the grill to the existing gas line.

- If local codes permit, use an outdoor flexible stainless steel tubing gas connector, design-certified by CSA International, to connect the grill to the rigid gas supply line. A 5/8" diameter line is recommended. Using a wrench to tighten, connect the gas supply to the grill.

Use pipe-joint compound on all non-flared male threads. Do not kink or damage the flexible connector when moving the grill.

- Pipe-joint compounds suitable for use with Natural gas must be used. Do not use TEFLON[®]† tape.

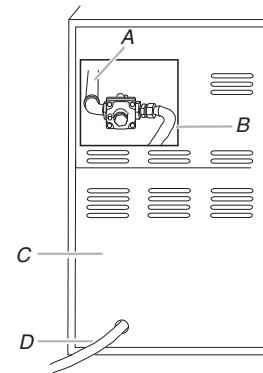

A. Grill gas pipe
B. New ANSI Z21.54 certified gray hose
C. Rear of grill
D. To Natural gas supply

2. Open the manual shutoff valve in the gas supply line. The valve is open when the handle is parallel to the gas pipe.

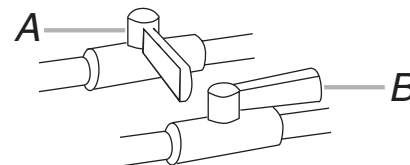

A. Closed valve
B. Open valve

3. Test all connections by brushing on an approved noncorrosive leak-detection solution. Bubbles will show a leak. Correct any leak found.
4. The igniter battery is not factory installed. A 1.5 volt “D” size alkaline battery is located in the accessory box on the grill grate. Install battery at this time following the instructions in the “Replacing the Igniter Battery” section. (s models only)
5. Go to “Check and Adjust the Burners” section.

†[®]TEFLON is a registered trademark of E.I. Du Pont De Nemours and Company.

Plug in Grill

! WARNING



Electrical Shock Hazard

Plug into a grounded 3 prong outlet.

Do not remove ground prong.

Do not use an adapter.

Do not use an extension cord.

Failure to do so can result in death or electrical shock.

1. Plug into a grounded 3-prong outlet.

Style 2 - Built-In Outdoor Grill Installation

! WARNING

Excessive Weight Hazard

Use two or more people to move and install grill.

Failure to do so can result in back or other injury.

- Unpack grill. Remove all packaging materials and remove grill from carton.
- Move grill close to desired outdoor location.
- Open the hood.

Remove Packaging Material Inside the Grill

1. Cut the tiedowns holding the grates together.
2. Remove rotisserie skewer (on some models), warming shelf and grill grates from inside the grill and remove packaging material.
3. Remove foam block and wrap from inside the grill.

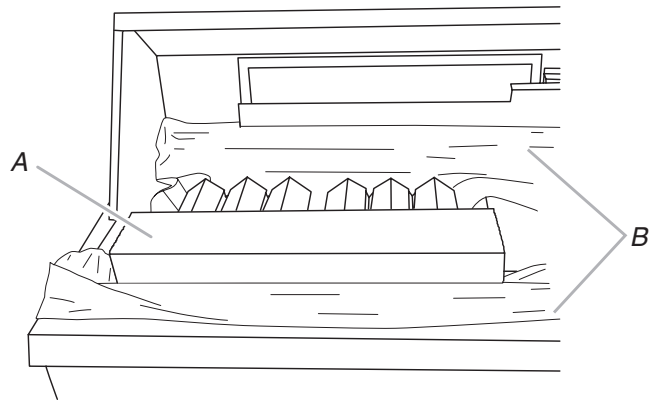

A. Foam block
B. Foam wrap

4. Replace the grill grates.
5. Place warming shelf on brackets as shown.

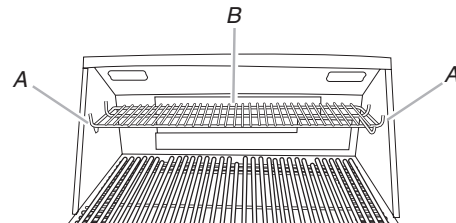

A. Warming shelf brackets
B. Warming shelf

6. Dispose of/recycle all packaging material.

Make Gas Connection

NOTE: If grill has been converted to LP gas, follow instructions in “LP Gas Conversion” at the end of this section.

! WARNING



Fire Hazard

Do not use grill near combustible materials.

Do not store combustible materials near grill.

Doing so can result in death or fire.

Natural Gas Use

This installation must conform with local codes and ordinances. In the absence of local codes, installations must conform with either the National Fuel Gas Code ANSI Z223.1 -latest edition, or CAN/CGA-B149.1 Natural Gas and Propane installation code.

1. Place grill into outdoor enclosure, but leave enough room in back to connect to gas supply and electrical plug-in.

! WARNING



Explosion Hazard

Use a new CSA International approved “outdoor” gas supply line.

Securely tighten all gas connections.

Failure to do so can result in death, explosion, or fire.

2. Make gas connections.

A combination of pipe fittings must be used to connect the grill to the existing gas line.

- If local codes permit, use an outdoor flexible stainless steel tubing gas connector, design-certified by CSA International, to connect the grill to the rigid gas supply line. A 5/8" diameter line is recommended. Using a wrench to tighten, connect the gas supply to the grill. Use pipe joint compound on all non-flared male threads. Do not kink or damage the flexible connector when moving the grill.
- Pipe-joint compounds suitable for use with Natural gas must be used. Do not use Teflon® tape

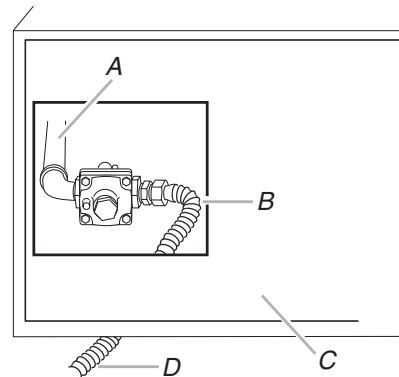

- A. Grill gas pipe
- B. New CSA International approved “outdoor” flexible gas supply line
- C. Rear of grill
- D. To Natural gas supply

3. Open the manual shutoff valve in the gas supply line. The valve is open when the handle is parallel to the gas pipe.

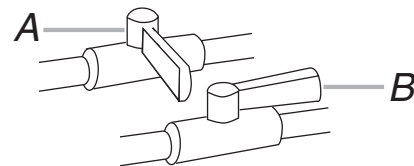

- A. Closed valve
- B. Open valve

4. Test all connections by brushing on an approved noncorrosive leak-detection solution. Bubbles will show a leak. Correct any leak found.

Plug in Grill

1. This built-in outdoor grill comes with a power transformer plug assembly for the grill lights. Plug in the single-prong plug in the receptacle on the left underside of the grill.

! WARNING

Electrical Shock Hazard Plug into a grounded 3 prong outlet. Do not remove ground prong. Do not use an adapter. Do not use an extension cord. Failure to do so can result in death or electrical shock.

2. Plug into a grounded 3-prong outdoor outlet.
3. The igniter battery is not factory installed. A 1.5 volt “D” size alkaline battery is located in the accessory box on the grill grate. Install battery at this time following the instructions in “Replacing the Igniter Battery” section. (s models only)
4. Gently slide grill completely into outdoor enclosure.
5. Now go to the “Check and Adjust the Burners” section.

If Converting to LP Gas

! WARNING

Explosion Hazard Use a new CSA International approved “outdoor” gas supply line. Securely tighten all gas connections. If connected to LP, have a qualified person make sure gas pressure does not exceed 11” (28 cm) water column. Examples of a qualified person include: Licensed heating personnel, authorized gas company personnel, and authorized service personnel. Failure to do so can result in death, explosion, or fire.

IMPORTANT: A 20 lb LP gas fuel tank must be purchased separately.

IMPORTANT: The gas pressure regulator/hose assembly supplied with the conversion kit must be used. Replacement gas pressure regulator/hose assembly specific to your model, is available from your outdoor grill dealer.

To Install the 20 lb LP Gas Fuel Tank:

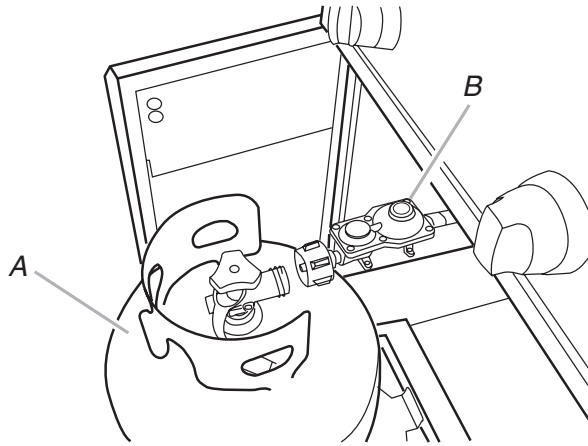
1. Install the 20 lb LP gas fuel tank into the compartment below the grill.
2. Screw the gas pressure regulator/hose assembly to the 20 lb LP gas fuel tank as shown.



A. 20 lb LP gas fuel tank
B. Gas pressure regulator/hose assembly

3. Turn on the gas supply. Wait a few minutes for gas to move through the gas line.
4. Test all connections by brushing on an approved noncorrosive leak-detection solution. Bubbles will show a leak. Correct any leak found.
5. The igniter battery is not factory installed. A 1.5 volt "D" size alkaline battery is located in the accessory box on the grill grate. Install battery at this time following the instructions in "Replacing the Igniter Battery" section. (s models only)
6. Go to "Check and Adjust the Burners" section.

Check and Adjust the Burners

The burners are tested and factory-set for most efficient operation. However, variations in gas supply and other conditions may make minor adjustments to air shutter or low flame setting necessary.

It is recommended that a qualified person make burner adjustments.

NOTE: The rotisserie burner cannot be adjusted.

Checking and adjusting the grill burner flames requires removing the grate and sear plates.

Burner Flame Characteristics

The flames of the grill burners and side burners (on some models) should be blue and stable with no excessive noise or lifting (LP gas flames will have a slightly yellow tip). A yellow flame indicates not enough air. If flame is noisy or lifts away from the burner, there is too much air. Some yellow tips on flames when the burner is set to HI setting are acceptable as long as no carbon or soot deposits appear.

Check that burners are not blocked by dirt, debris, insect nests, etc. and clean as necessary. If they are clean, adjust air shutters as needed.

IMPORTANT: Before adjusting air shutters, let burners cool completely.

To Adjust:

1. Light grill using information in the "Outdoor Grill Use" section.
2. Observe flame to determine which burners need adjustment and how the flame is acting.

- Turn off the valve and wait until grill and burners cool completely.
- Remove grill grates and sear plates.
- Remove the 2 screws that hold the burner in place. Remove gas burner from the grill.

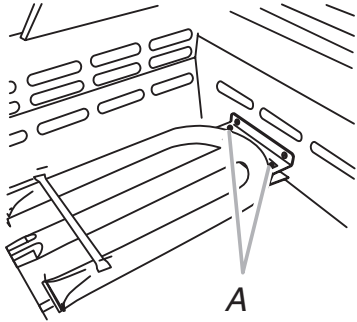

A. 2 screws

- If flame is yellow (not enough air), turn air shutter adjustment screw counterclockwise.

If flame is noisy or lifts away from burner (too much air), turn air shutter adjustment screw clockwise.

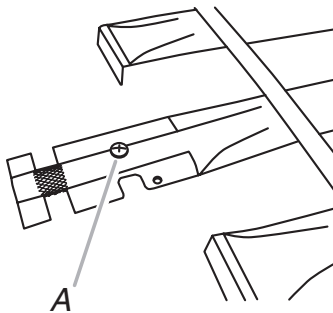

A. Air shutter adjustment screw

Adjustment should be made clockwise or counterclockwise from 1/8" (3.2 mm) to 1/4" (6.4 mm).

- Replace gas burner, sear plates and grates.
- Light grill using information in the "Outdoor Grill Use" section.

See "Burner Flame Characteristics"

Low Flame Adjustment

If flame goes out on the "LO" setting, the low flame setting must be adjusted.

- Turn off the valve and wait until grill and burners are cool.
- Remove grill grates and sear plates.
- Light grill using information in the "Outdoor Grill Use" section.
- Turn burner to its lowest setting and remove knob.
- Hold valve stem with pliers and insert a thin flat-blade screwdriver into the shaft.
- Watch the flame and slowly turn the screwdriver counterclockwise.
- Adjust flame to minimum stable flame.

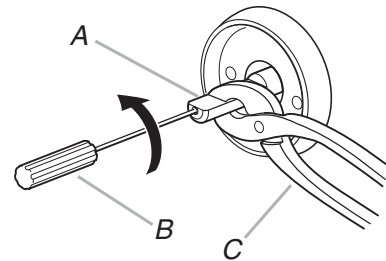

A. Valve stem
B. Flat-blade screwdriver
C. Pliers

- Replace the control knob and turn off the burner.
- Repeat steps 3 through 8 for each burner if needed.
- Replace the sear plates and grates after the burners have cooled.

PRODUCT OPERATION

OUTDOOR GRILL USE

Control Panel (S Models)

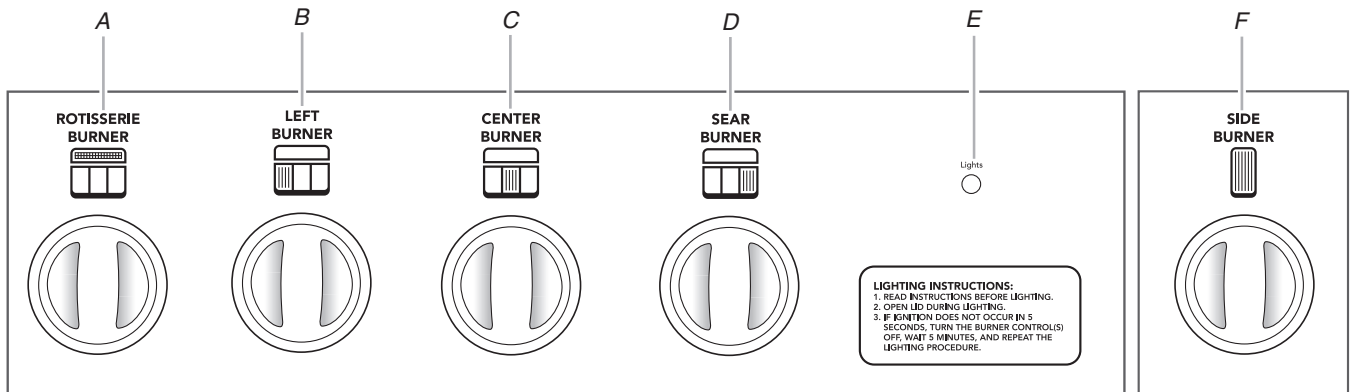

A. Rotisserie burner control knob
 B. Left grill burner control knob
 C. Center grill burner control knob

D. Sear burner control knob
 E. Hood lights
 F. Side burner control knob

Control Panel (U Models)

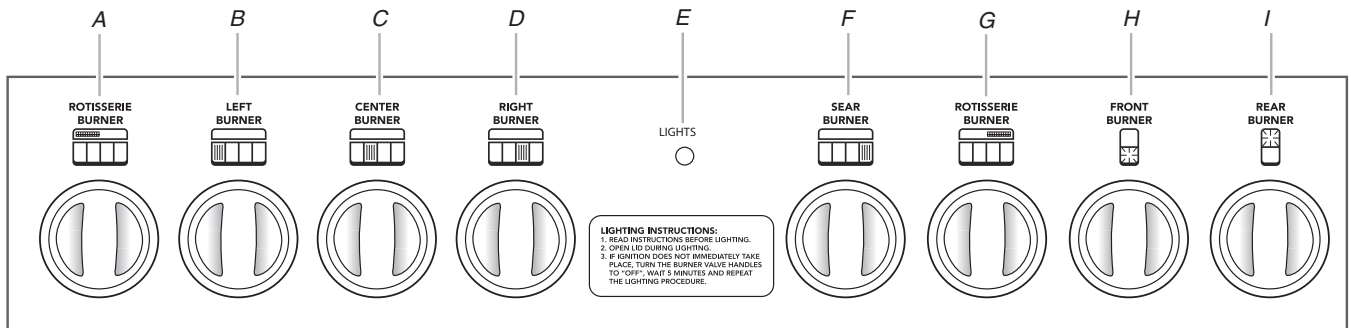

A. Left rotisserie burner control knob
 B. Left grill burner control knob
 C. Center grill burner control knob

D. Right grill burner control knob
 E. Electronic grill display
 F. Sear burner control knob

G. Right rotisserie burner control knob
 H. Front side burner control knob
 I. Rear side burner control knob

This Job Aid covers several different models. The grill you have purchased may have some or all of the features listed. The locations and appearances of the features shown here may not match those of your model.

Using Your Outdoor Grill

! WARNING



Explosion Hazard

Do not store fuel tank in a garage or indoors.

Do not store grill with fuel tank in a garage or indoors.

Failure to follow these instructions can result in death, explosion, or fire.

! WARNING



Fire Hazard

Do not use grill near combustible materials.

Do not store combustible materials near grill.

Doing so can result in death or fire.

! WARNING

Food Poisoning Hazard

Do not let food sit for more than one hour before or after cooking.

Doing so can result in food poisoning or sickness.

Inspect the LP Gas Fuel Tank Supply Hose

Inspect the gas pressure regulator/hose assembly before each use.

1. Open the right-hand drawer and slide 20 lb LP gas fuel tank out.
2. Inspect the entire gas pressure regulator/hose assembly for cuts, abrasions, or excessive wear.
3. If necessary, replace the gas pressure regulator/hose assembly before using the grill.

Contact the dealer and use only replacement hoses specified for use with the grill.

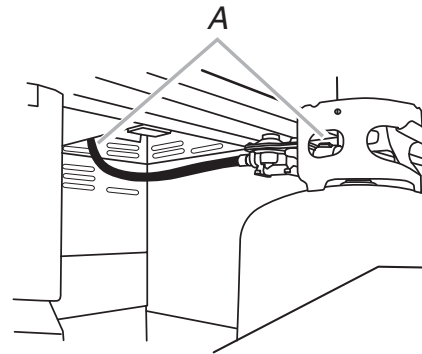

A. Gas pressure regulator/hose assembly

Prepare the Gas Supply

1. Open the hood completely. Do not light burners with the hood closed.
2. Make sure control knobs are turned to OFF. The drip pan must be in place and pushed all the way to the back.

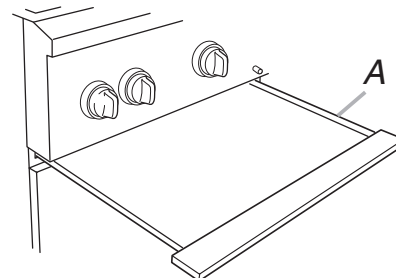

A. Drip pan

Turn the Gas Supply On

1. For freestanding outdoor grills using a 20 lb LP gas fuel tank:

Slowly open the tank valve.

NOTE: If flow limiting device activates, your grill may not light. If your grill does light, the flames will be low and will not heat properly. Turn tank valve and all control knobs off and wait 30 seconds. After shutting off the tank, very slowly open tank valve and wait 5 seconds before lighting.

2. For outdoor grills using gas supply source other than a 20 lb LP gas fuel tank:

Open the manual shutoff valve in the gas supply line. The valve is open when the handle is parallel to the gas pipe.

Lighting the Grill and Infrared Sear Burner

1. Do not lean over the grill.
2. Select the burner you want to light. Push in and turn the grill burner control knob to LITE/HI, while continuing to hold it in.

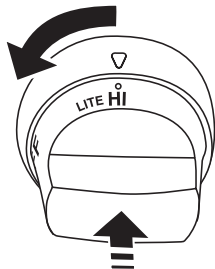

3. You will see the igniter glow. When burner is lit, release the knob. Turn knob to desired setting.
4. Repeat for each of the other burners as needed.

IMPORTANT: If burner does not light immediately, turn the burner knob to OFF and wait 5 minutes before relighting.

- Preheat grill on high (use all grill burners) 10 minutes. The hood must be closed during preheating. Do not use back rotisserie burner for preheating. Preheating provides the high heat needed to brown and seal the juices.

- Shorten the preheat time when grilling high-fat cuts of meat or poultry, such as chicken thighs. This will help reduce flare-ups

Manually Lighting Main and Infrared Grill Burners

1. Do not lean over the grill.
2. Remove the manual lighting extension (see following illustration) and attach a match to the split ring.

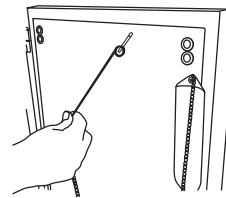

Freestanding grills - right-hand cabinet door

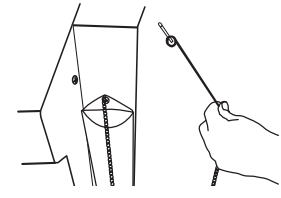

Built-in grills - right-hand side flange

3. Strike the match to light it.
4. Guide the lit match between the grill grate and one of the slots in the sear plate.

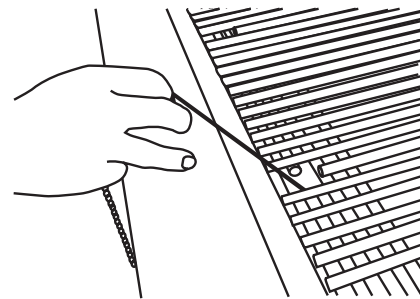

5. Push in and turn the burner knob to LITE/HI for the burner closest to the lit match. The burner will light immediately. When burner is lit, turn knob to desired setting.

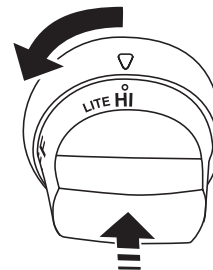

6. Repeat steps 3 through 6 for each main burner.
7. Remove match and replace manual lighting extension inside the cabinet drawer.

IMPORTANT:

If burner does not light immediately, turn the burner knob to OFF and wait 5 minutes before relighting.

If any burners do not light after attempting to light them manually, contact the KitchenAid Customer eXperience Center. See the “Assistance or Service” section.

Using Your Infrared Sear Burner

Infrared grilling produces intense heat which quickly sears the meat. Searing locks in flavor and juices while allowing the outer surface to absorb smoke and food aroma that is produced as grease and drippings are vaporized by the burner. The result is a crisp, flavorful outside with a tender, juicy inside.

- Preheat the infrared sear burner for 5 minutes.
- Ensure that meats are fully thawed and that all excess fat is trimmed away prior to grilling.
- Leave the burner set to HI when placing food on the grill to sear.
- Use the sear burner to sear meat 1 to 2 minutes on each side, then move the meat to the main grill cooking surface to finish grilling to the desired doneness.

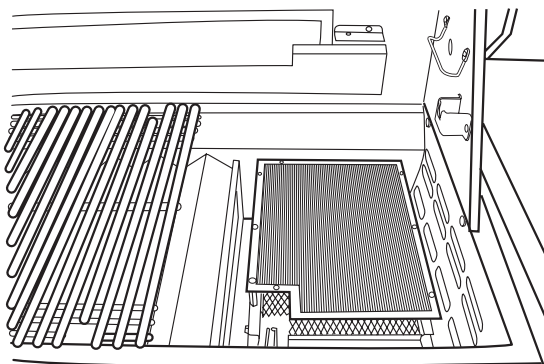

NOTE: View is shown with grates removed. Grates are to be in place when using the infrared sear burner.

Using Your Side Burner

⚠ WARNING



Burn Hazard

Do not let the burner flame extend beyond the edge of the pan.
Doing so can result in burns.

**Lighting the Side Burner
(u models only)**

1. Remove the side burner cover. Do not light burners with the cover on.
2. Do not lean over the grill.
3. Push in and turn the control knob to LITE/ HI and hold in.

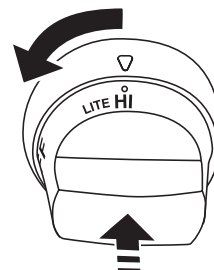

4. You will see the igniter glow. When burner is lit, release the knob. Turn knob to desired setting.
5. Repeat for each of the other burners as needed.

IMPORTANT: If burner does not light immediately, turn the burner knob to OFF and wait 5 minutes before relighting.

Manually lighting the side burner

1. Do not lean over the grill.
2. Remove the manual lighting extension (see following illustration) and attach a match to the split ring.

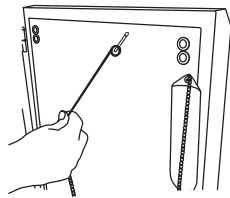

Freestanding grills - right-hand cabinet door

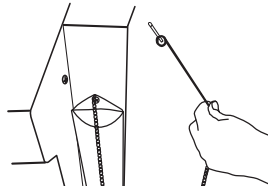

Built-in grills - right-hand side flange

3. Strike the match to light it.
4. Guide the match to the burner you wish to light.

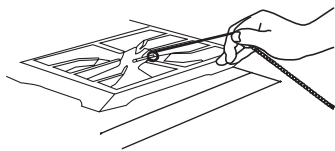

5. Push in and turn the burner knob to LITE/HI for the burner closest to the lit match. The burner will light immediately. When burner is lit, turn knob to desired setting.

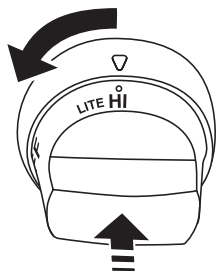

6. Repeat steps 3 through 6 for each burner.
7. Remove match and replace manual lighting extension inside the cabinet drawer.

IMPORTANT:

If burner does not light immediately, turn the burner knob to OFF and wait 5 minutes before relighting.

If any burners do not light after attempting to light them manually, contact the KitchenAid Customer eXperience Center. See the "Assistance or Service" section.

Using Your Rotisserie

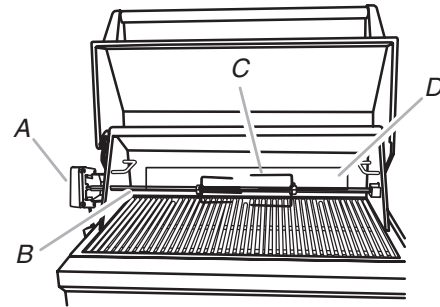

A. Rotisserie motor
B. Spit rod
C. Rotisserie fork
D. Rotisserie burner

For best cooking results, do not use main grill burners when using the rotisserie.

The rotisserie system is designed to cook food from the rear using intense, searing infrared heat.

NOTE: To avoid product damage when not using the rotisserie, remove motor and store indoors. Remove spit rod and forks. Store out of reach of children.

To Use:

1. Remove warming shelf.
2. Mount rotisserie motor on the grill's mounting bracket. Position it securely into support bracket slots. Plug single-prong plug into rotisserie motor.

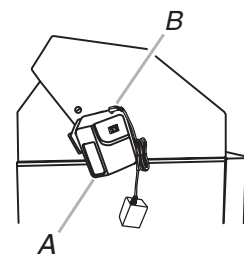

A. Rotisserie motor
B. Single-prong power cord

3. To load the spit rod, slide one of the rotisserie forks onto the spit rod with prongs facing inward.
4. Push spit rod through the center of the food, then slide second rotisserie fork into position.
5. Center the food and rotisserie forks on spit rod and tighten wing nuts on the rotisserie

forks. If necessary, secure loose food portions with butcher's string only.

6. Once the food is positioned on spit rod, place pointed end of rod through the hole in the left side of the grill and into the rotisserie motor, then lower the notched end of the spit rod onto the support bracket on the opposite side.

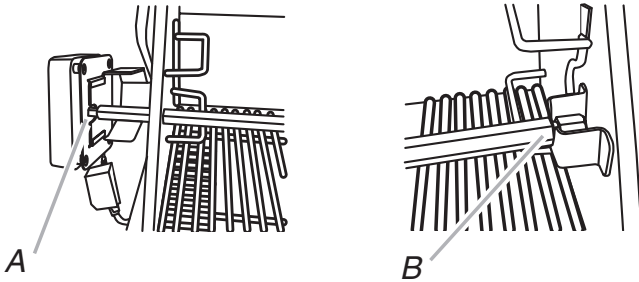

A. Pointed end of spit rod
B. Notched end of spit rod

7. Check that food is centered with the rotisserie burner. If not, loosen wing nuts, reposition food and retighten wing nuts.

⚠ WARNING

Electrical Shock Hazard

Plug into a grounded 3 prong outlet.

Do not remove ground prong.

Do not use an adapter.

Do not use an extension cord.

Failure to do so can result in death or electrical shock.

8. Plug into a grounded 3 prong outdoor.
9. Turn on the rotisserie motor and light the rotisserie burner. See the following "Lighting the Rotisserie Burner" section.

Lighting the Rotisserie Burner (u models only)

1. Do not lean over the grill.
2. Push in and turn the control knob to LITE/HI. You will see the igniter glow.

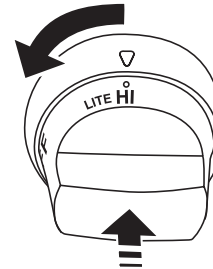

3. When the rotisserie burner lights, continue to hold the knob in for another 10 seconds, then release the knob and burner will stay lit.

IMPORTANT: If the rotisserie burner does not light immediately, turn the burner knob to OFF and wait 5 minutes before relighting.

Lighting the Rotisserie Burner (s models only)

1. Do not lean over the grill.
2. Push in and turn the control knob to LITE/HI. You will hear the "snapping" sound of the spark.

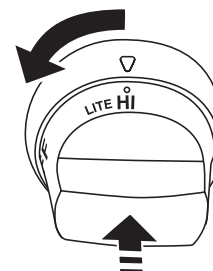

3. When the rotisserie burner lights, continue to hold the knob in for another 10 seconds, then release the knob and burner will stay lit. You will hear the "snapping" sound of the spark until the knob is released.

IMPORTANT: If the rotisserie burner does not light immediately, turn the burner knob to OFF and wait 5 minutes before relighting.

Manually Lighting the Rotisserie Burner

1. Do not lean over the grill.
2. Remove the manual lighting extension (see following illustration) and attach a match to the split ring.

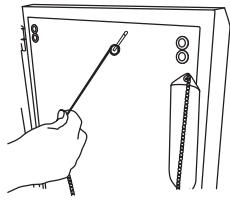

Freestanding grills - right-hand cabinet door

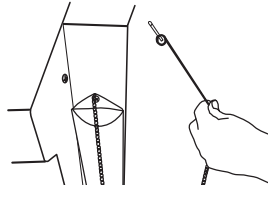

Built-in grills - right-hand side flange

3. Strike the match to light it.
4. Gently hold the lit match close to the rotisserie burner.

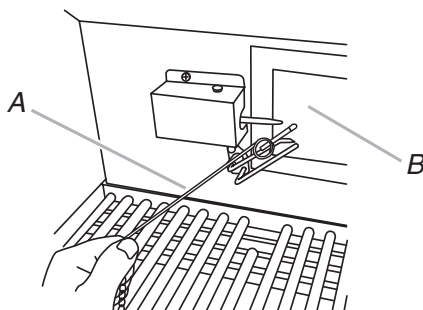

A. Lighting extension
B. Rotisserie burner

5. Push in and turn the control knob to LITE/ HI. Hold this knob in for 10 seconds after the burner is lit.

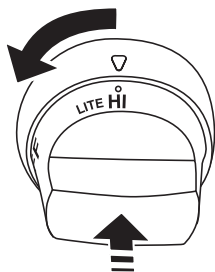

IMPORTANT: If the rotisserie burner does not light immediately, turn the rotisserie burner control knob to “OFF” and wait 5 minutes before relighting.

6. Remove the match and replace the manual lighting extension inside the cabinet drawer.

USING YOUR WARMING DRAWER Freestanding Ultima Outdoor Grills Only

Control Panel

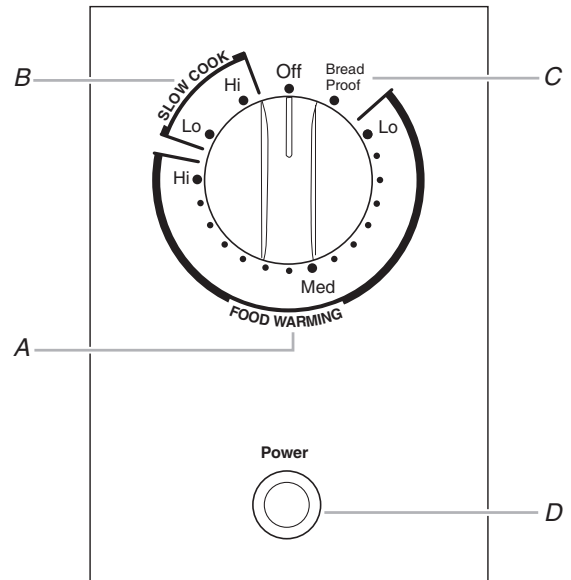

A. Warming drawer temperature control zone
B. Slow cooker temperature control zone
C. Proofing bread control position
D. Blue power indicator light

Control Knob

! WARNING

Food Poisoning Hazard

Do not let food sit for more than one hour before or after cooking.

Doing so can result in food poisoning or sickness.

Push in and turn the control knob to turn on the warming drawer. The blue power indicator light will turn on and remain on when the warming drawer is in operation.

When finished, turn the control knob to OFF to turn off the warming drawer. When the warming drawer is turned off the blue power indicator light will go out and the drawer will begin to cool.

The temperature is controlled by rotating the control knob to the desired setting. The temperature setting ranges from Lo to Hi on the warming drawer control to keep heated foods warm at the selected temperatures.

Moist-Dry Slide Control

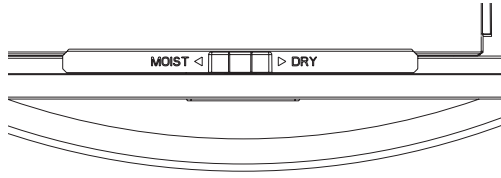

The Moist-Dry slide control allows you to open or close the vent slots in the door. The MOIST setting holds moisture in, while the DRY setting allows steam and moisture to escape from the drawer.

NOTE: Condensation may form on inner surfaces. This is normal. To keep foods moist, slide control to the MOIST setting, closing the vents. Closing the vents will seal the drawer and keep hot foods soft and moist.

To keep foods crisp, slide control to the DRY setting, opening the vents. Opening the vents releases moisture from the drawer and keeps hot foods crisp and dry. See the Warming Drawer Temperature Chart in the “Setting the Controls” section.

Setting the Controls

⚠ WARNING

Food Poisoning Hazard

Do not let food sit for more than one hour before or after cooking.

Doing so can result in food poisoning or sickness.

The warming drawer is ideal for keeping hot cooked foods at serving temperature. It is designed to operate properly at temperatures down to 32°F (0°C).

If the drawer is operated at temperatures colder than 32°F (0°C), performance may be affected.

Different types of food may be placed in the warming drawer at the same time.

When keeping several types of food hot, use the setting for the highest temperature food in the warming drawer. Place foods requiring the highest temperature on the bottom of the drawer and those foods requiring the lowest temperature on an elevated rack.

For best results, do not hold foods in the warming drawer longer than 1 hour. For smaller quantities or heat-sensitive foods, such as eggs, do not hold longer than 30 minutes.

Food must be cooked and at serving temperature before being placed in the warming drawer. Cover foods with a lid.

Breads, pastries, and fruit pies may be heated from room temperature on the Hi setting. Remove food from plastic bags and place in oven-safe container.

Oven-safe serving dishes and dinner plates can be heated while the warming drawer is preheating.

NOTE: To conserve heat, place cookware and positioning rack in the warming drawer before preheating.

To Use:

1. Push in and turn the control knob to the desired food warming setting: Lo (low), between Lo and Med (medium low), Med (medium), between Med and Hi (medium high), or Hi (high).

NOTE: For best results, meats, seafood, poultry and any foods containing meat, seafood or poultry must be set to medium or higher.

2. Select MOIST or DRY setting.
3. Allow warming drawer to preheat. Recommended minimum preheating times are 5 minutes for Lo, 10 minutes for Med, and 20 minutes for Hi.
4. Push in and turn the control knob to OFF when finished.

COMPONENT ACCESS

This section instructs you on how to service each component inside the Outdoor Gas Grill. The grill components and their locations are shown below.

COMPONENT LOCATIONS (TYPICAL)

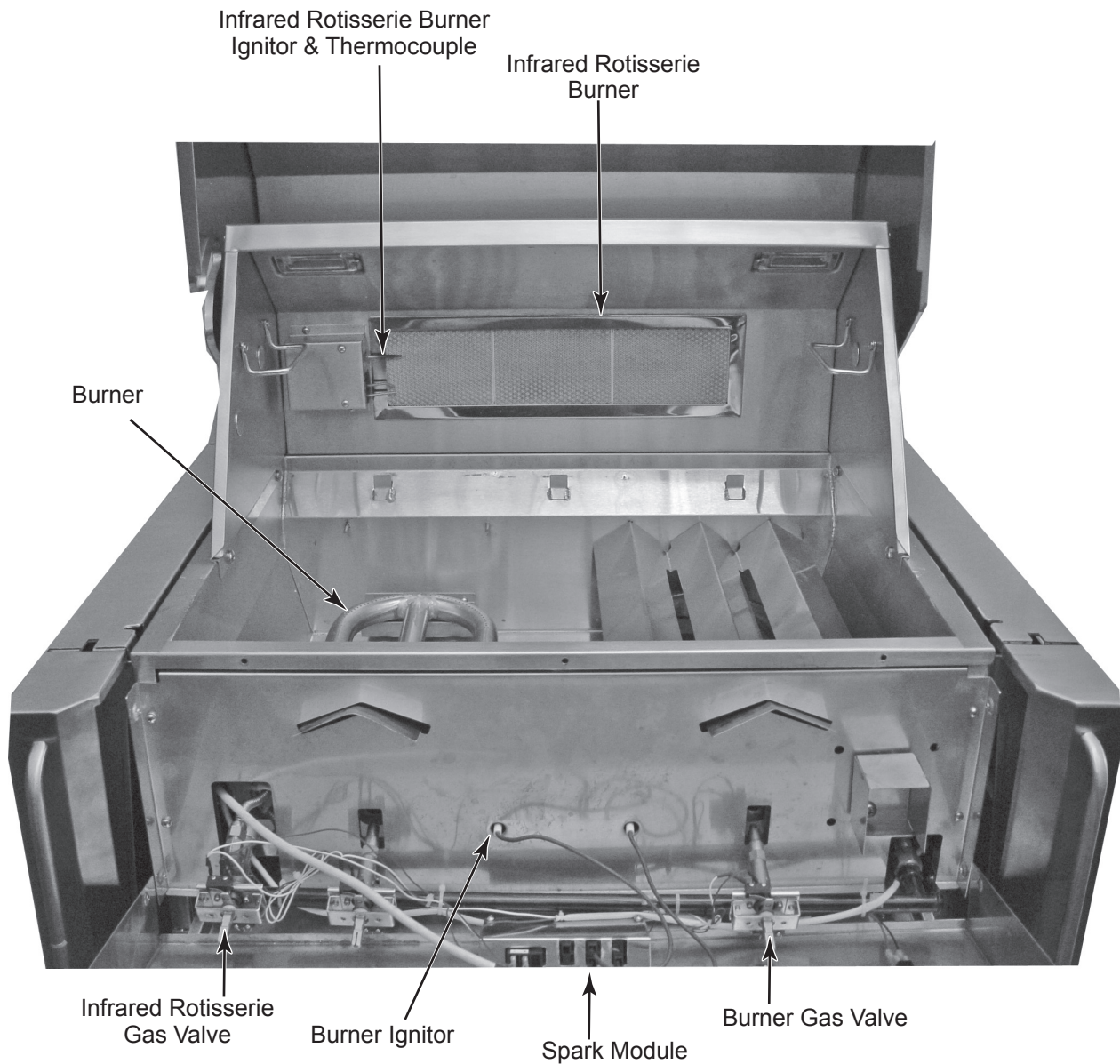

REMOVING THE CONTROL PANEL AND SPARK MODULE

⚠ WARNING



Electrical Shock Hazard
Disconnect power before servicing.
Replace all parts and panels before operating.
Failure to do so can result in death or electrical shock.

1. Turn off and disconnect the gas supply going to the grill.
2. Pull the knobs off the gas valves.

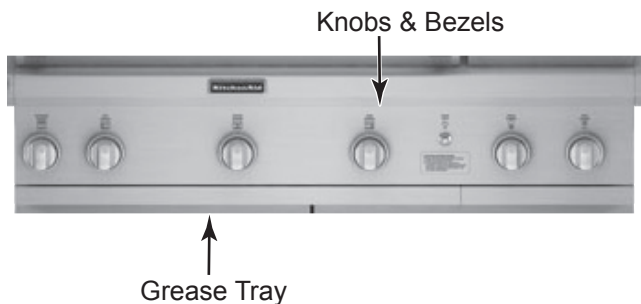

3. **To remove the control panel:**
 - a) Remove the two screws from each of the bezels and remove the bezels.



- b) Remove the two control panel mounting screws from each side on the control panel.

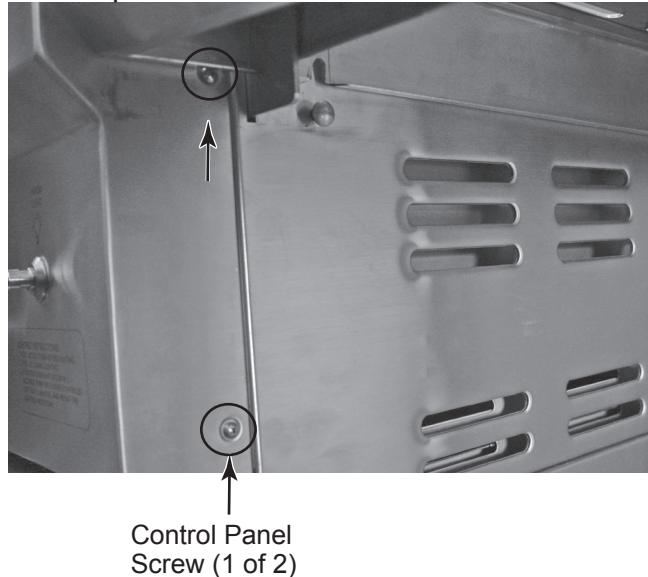

- c) Remove the three control panel mounting screws from inside of burner box after removing grates.

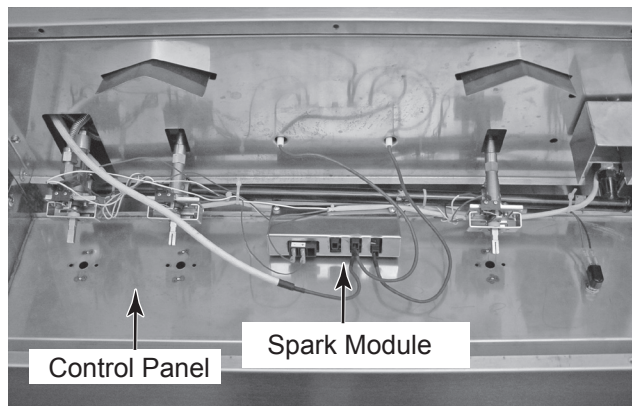
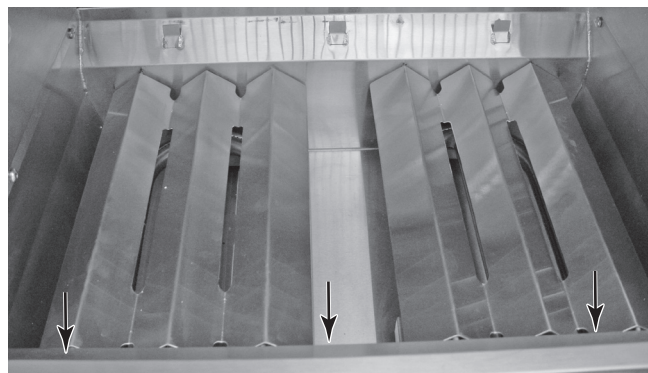

6. **To remove a spark module (s models only):**

- a) Remove the two spark module cover screws.
- b) Remove the cover from the spark module.

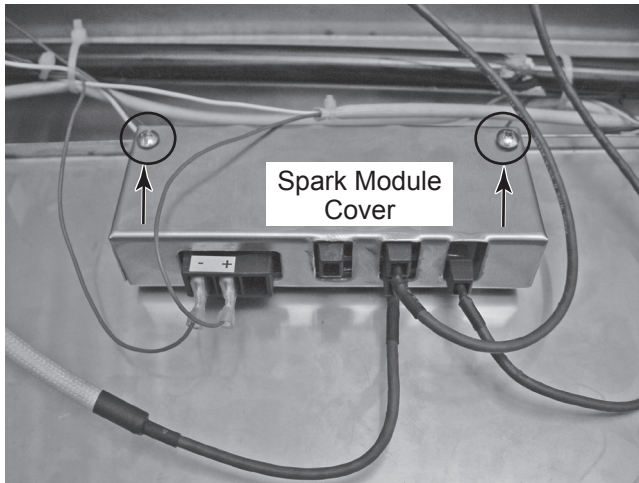

- c) Disconnect the wires from the terminals. NOTE: The wire connectors are different sizes to prevent miswiring. The two larger wire connectors are for the ignition switch, and the smaller wire connectors are for the ignitors. The ignitor connectors may be connected to any of the smaller terminals.

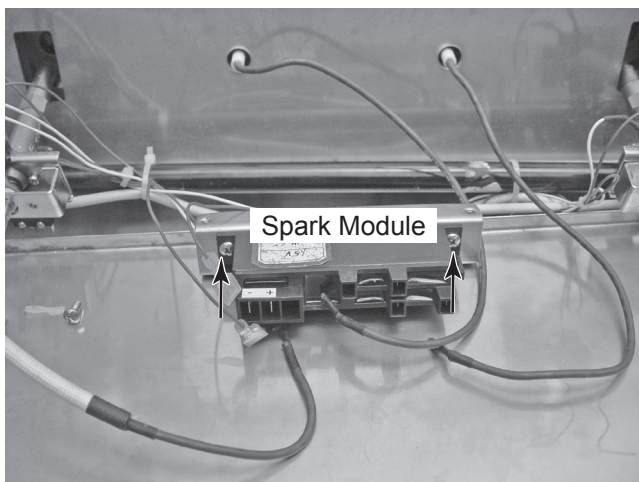

- d) Remove the two spark module screws and remove spark module.

REMOVING THE INFRARED ROTISSERIE BURNER HOT SURFACE OR SPARK IGNITOR & THERMOCOUPLE

⚠ WARNING



Electrical Shock Hazard

Disconnect power before servicing.

Replace all parts and panels before operating.

Failure to do so can result in death or electrical shock.

1. Turn off and disconnect the gas supply going to the grill.

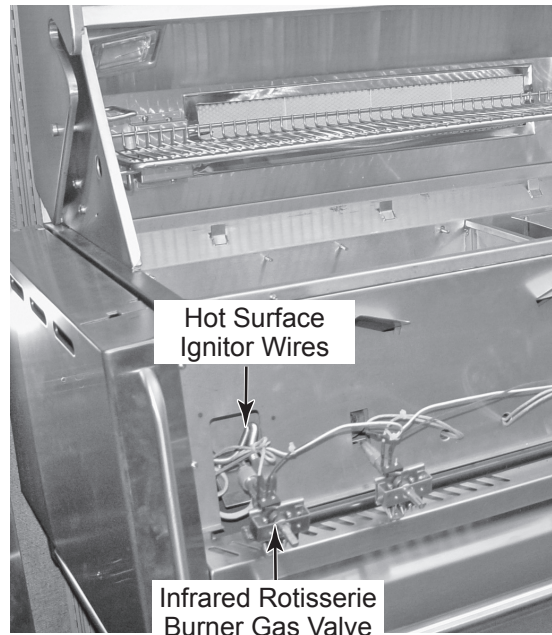

- c) Remove screw from the rear access panel and remove the panel.

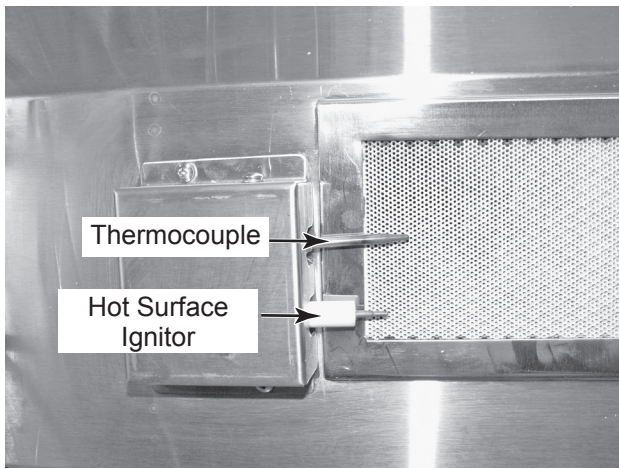

2. To remove the infrared rotisserie burner hot surface ignitor (u models only):

- a) Remove the control panel (see page 4-2 for the procedures).
- b) Disconnect the infrared rotisserie burner hot surface ignitor wire from igniter switch terminals.

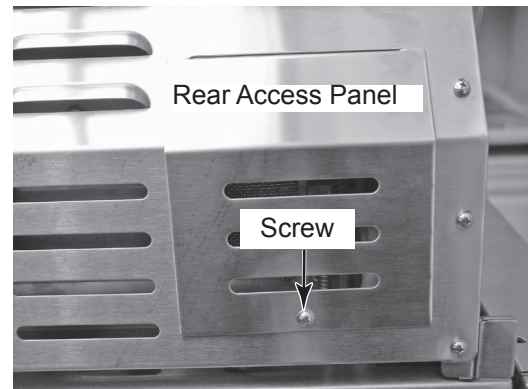

- d) Remove the screws from the infrared rotisserie burner ignitor & thermocouple cover and remove the cover.

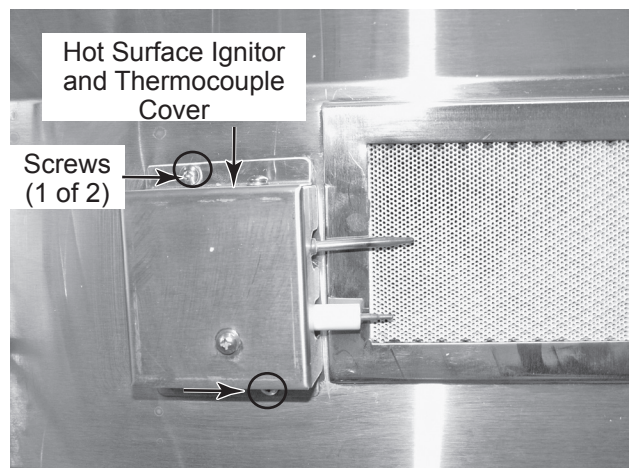

e) Remove the screw from the infrared rotisserie burner hot surface ignitor bracket and remove the hot surface ignitor from the unit.

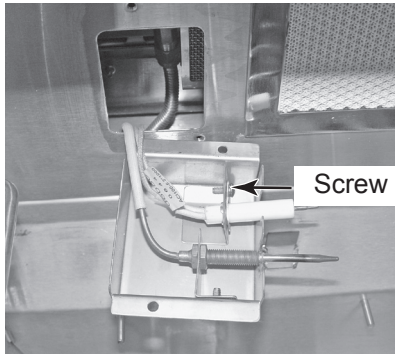

c) Remove screw from the rear access panel and remove the panel.

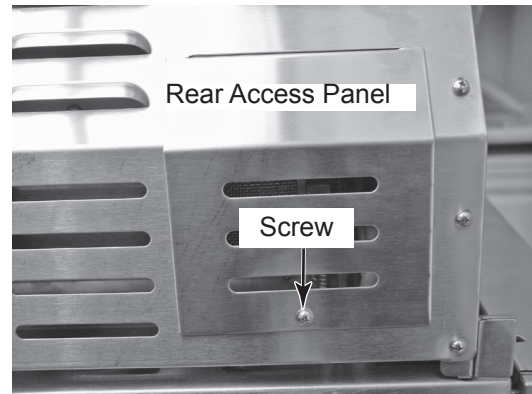

3. To remove the infrared burner spark ignitor (s models only):

d) Remove four screws from the infrared burner spark ignitor & thermocouple cover and remove the cover.

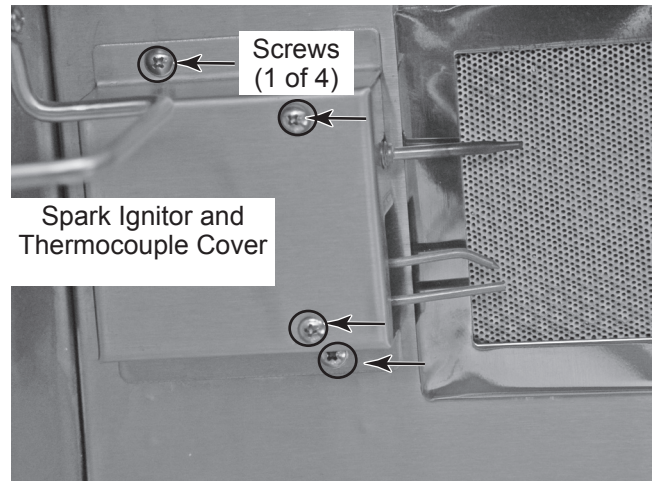
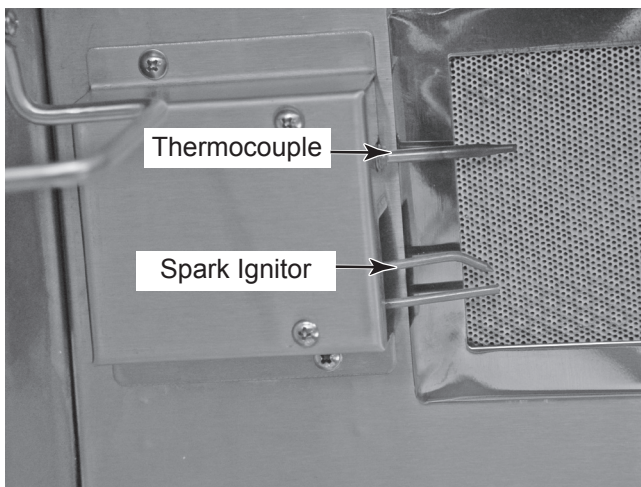

a) Remove the control panel (see page 4-2 and 4-3 for the procedures).

b) Disconnect the infrared rotisserie burner spark ignitor wire from spark module terminals.

e) Remove the screw from the infrared rotisserie burner spark ignitor bracket and remove the spark ignitor from the unit.

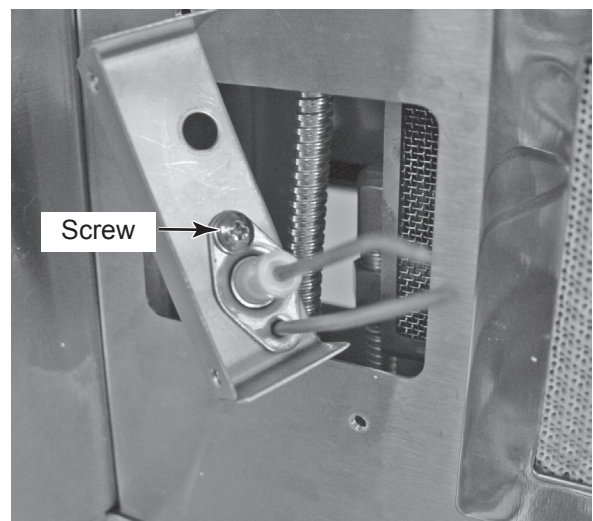
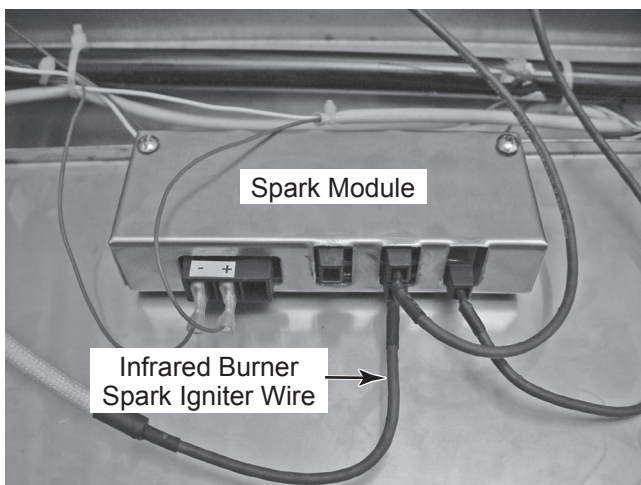

Continued on the next page.

4. To remove the thermocouple:

- a) Remove the control panel (see page 4-2 for the procedure).
- b) Unscrew the thermocouple connector from the infrared burner gas valve.

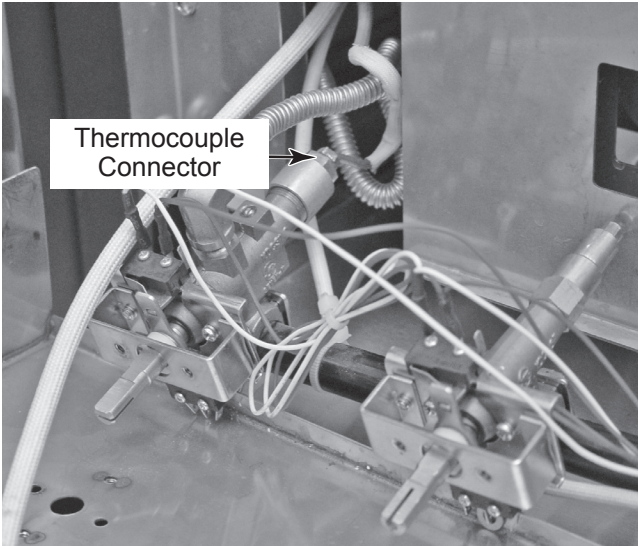

- c) Remove the rear panel and the infrared rotisserie burner ignitor & thermocouple cover (see steps 2c and 2d on page 4-4).
- d) Unscrew the thermocouple out of its holding clip.
- e) Pull the sensor tube through the two access holes at the rear of the unit, and remove the thermocouple.

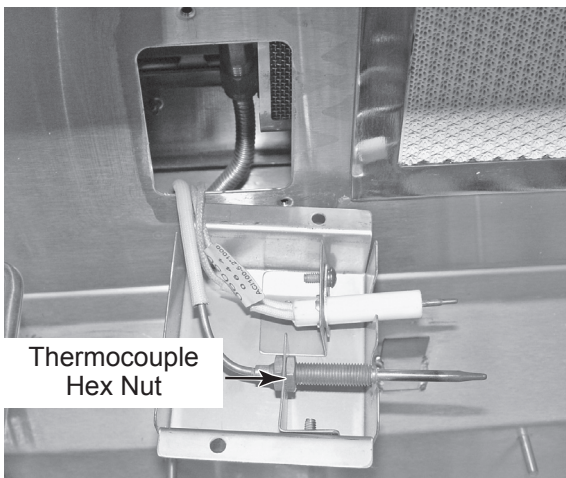

REMOVING THE INFRARED ROTISSERIE BURNER

⚠ WARNING



Electrical Shock Hazard
Disconnect power before servicing.
Replace all parts and panels before operating.
Failure to do so can result in death or electrical shock.

1. Turn off and disconnect the gas supply going to the grill.
2. Remove the infrared burner ignitor from the grill (see step 2 on page 4-4 for the procedure).
3. Remove the screw from the rear access panel and remove the panel.

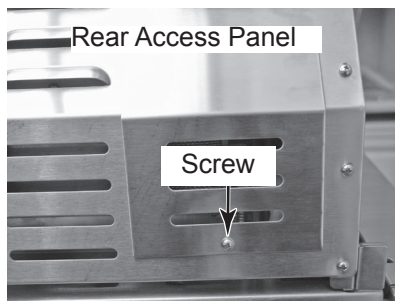

4. Disconnect the gas line fitting going to the infrared burner.

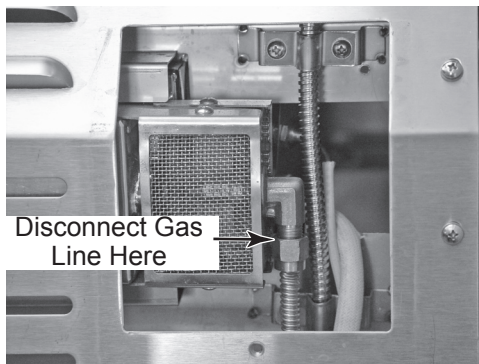

5. Remove two screws holding grill hood to hood assembly and remove hood.

6. Remove twelve screws holding rear panel to hood assembly.

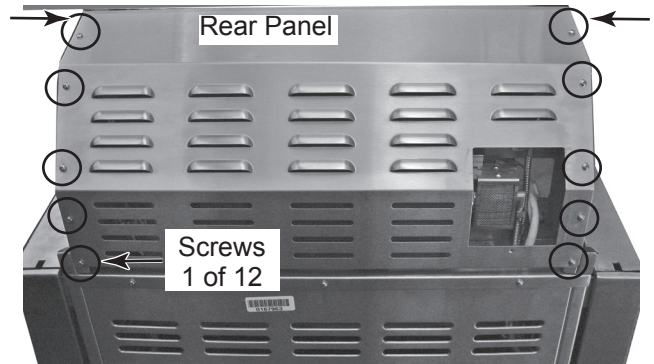

Rear Of Unit

7. Remove screws holding infrared rotisserie burner to hood assembly.

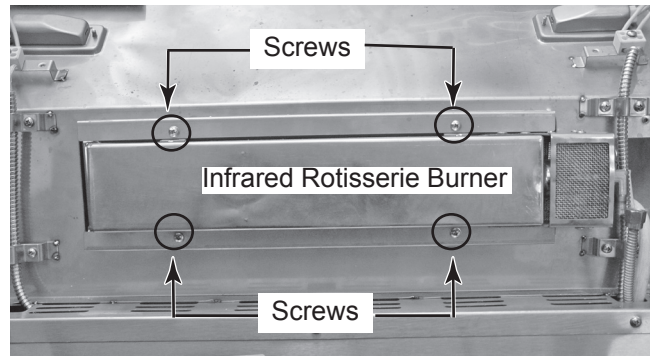

Rear Of Unit Hood Assembly

7. Slide infrared rotisserie burner forward out of hood assembly.

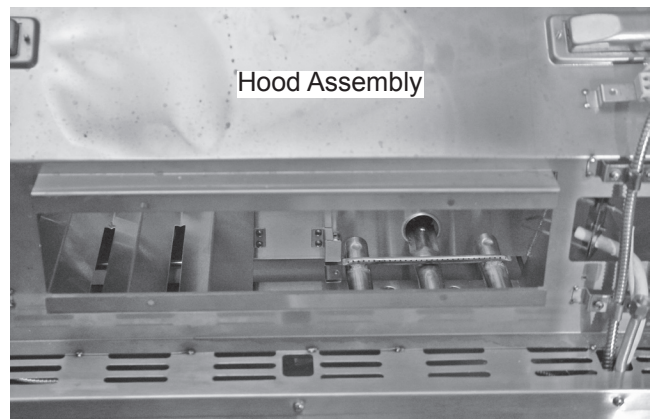

REASSEMBLY NOTE: Turn on the gas to the grill, and test all of the connections by brushing on an approved noncorrosive leak-detection solution. Bubbles will indicate a leak. Correct any leaks found.

REMOVING A BURNER, BURNER IGNITOR, INFRARED GAS VALVE, AND BURNER GAS VALVE

⚠ WARNING



Electrical Shock Hazard

Disconnect power before servicing.
Replace all parts and panels before operating.

Failure to do so can result in death or electrical shock.

1. Turn off and disconnect the gas supply going to the grill.
2. **To remove a burner:**
 - a) Remove the grates and the sear plates.

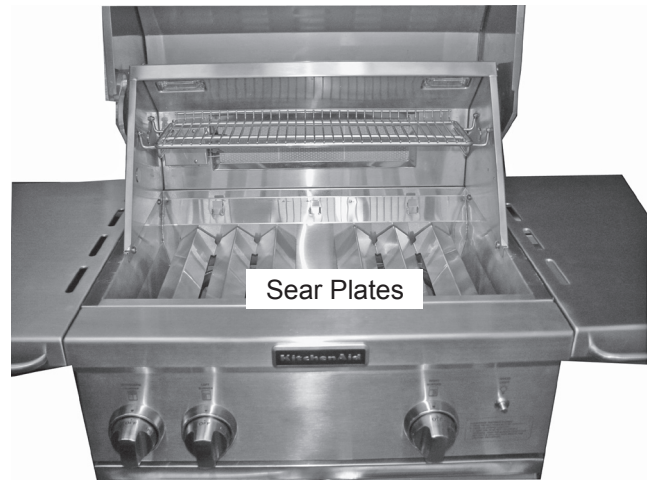

- b) Remove two screws from rear of the burner, lift from the rear and pull the air shutter off the gas valve orifice, and remove the burner.

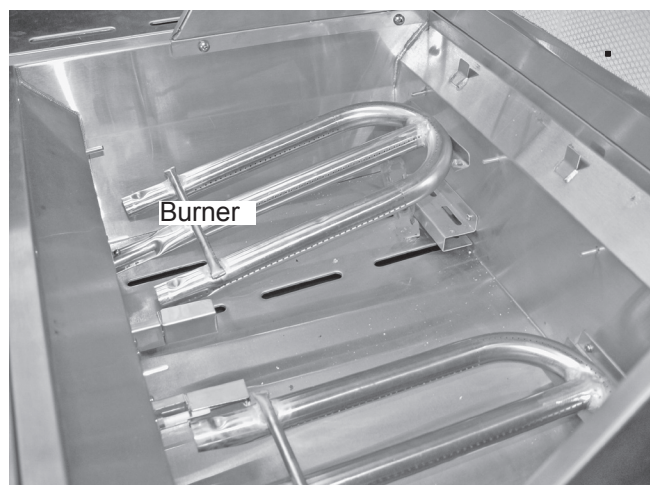
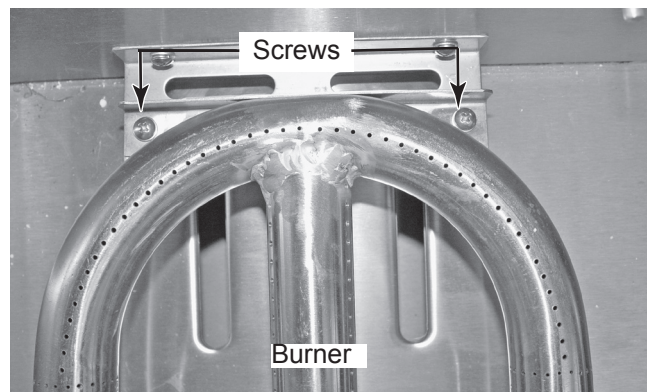

3. **To remove a burner ignitor:**
- a) Remove the grates and the sear plates.
 - b) Remove the control panel and the spark module (see pages 4-2 and 4-3 for the procedures).
 - c) Remove the four hex screws from the front baffle, pull the top of the front baffle forward, and remove it.

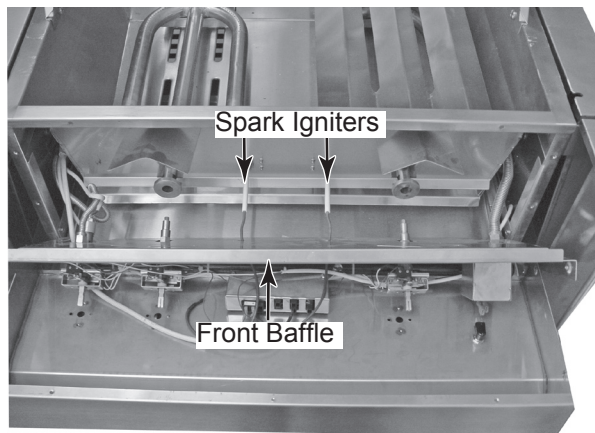
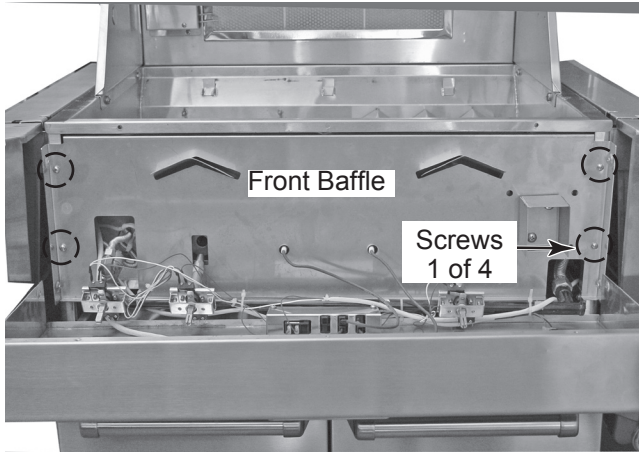

- d) Remove the hex nut from the ignitor bracket and slide the spark igniter out the front of unit.

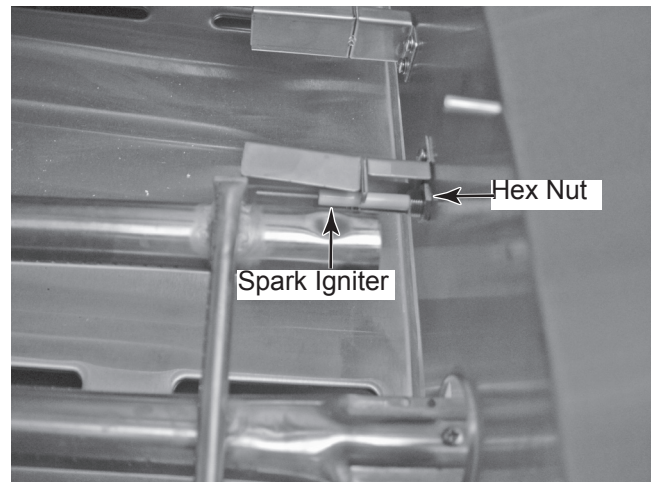

Continued on the next page.

4. **To remove the Infrared burner gas valve:**

- a) Remove the control panel (see page 4-2 for the procedure).
- b) Remove the thermocouple and gas line connectors from the infrared burner gas valve.
- c) Remove the red and white wires from the gas valve.
- d) Unscrew the 8mm hex bolt from the infrared burner valve and remove it from the manifold.

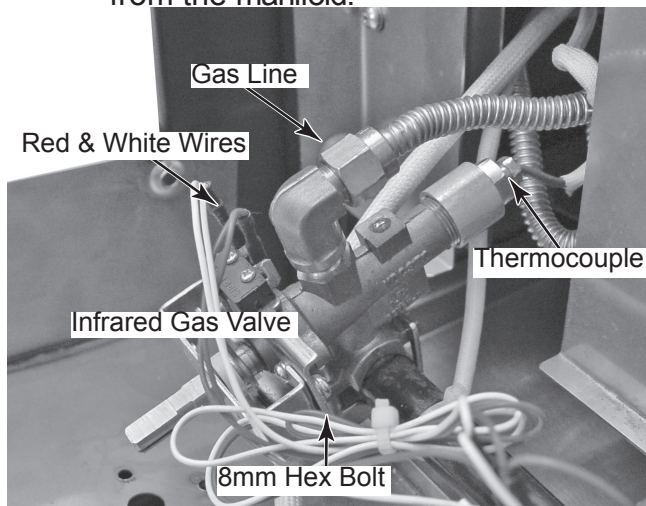

REASSEMBLY NOTES:

- When you replace a gas valve, use an appropriate thread sealant that is approved for use with L.P. gas.
- Turn on the gas to the grill, and test all of the connections by brushing on an approved noncorrosive leak-detection solution. Bubbles will indicate a leak. Correct any leaks found.

5. **To remove a burner gas valve:**

- a) Remove the control panel (see page 4-2 for the procedure).
- b) Remove the red and white wires from the gas valve.
- c) Remove 8mm hex bolt from the gas valve.
- d) Remove the burner gas valve from the manifold and remove the valve.

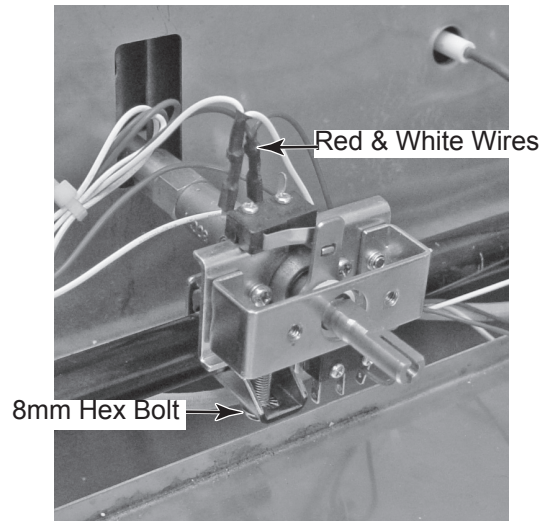

REASSEMBLY NOTES:

- When you replace a gas valve, use an appropriate thread sealant that is approved for use with L.P. gas.
- Turn on the gas to the grill, and test all of the connections by brushing on an approved noncorrosive leak-detection solution. Bubbles will indicate a leak. Correct any leaks found.

REMOVING THE BATTERY (S MODEL ONLY)

1. To remove the battery:

a) Open the battery holder cover by pulling it from top down.

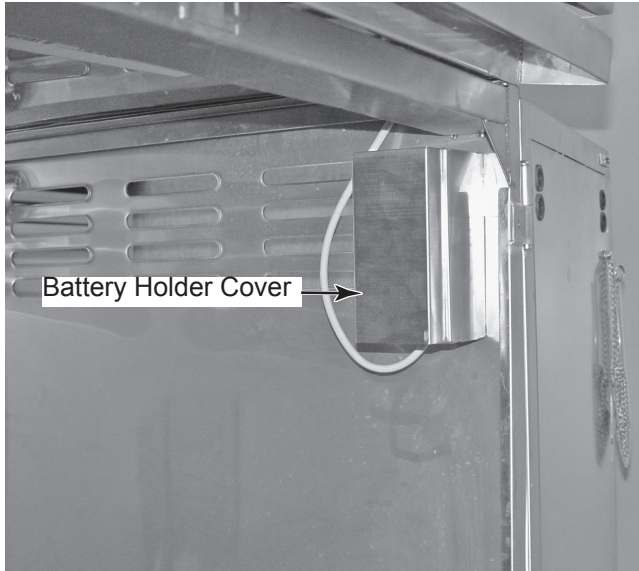

b) Pull the battery compartment cover left to right to open battery compartment.

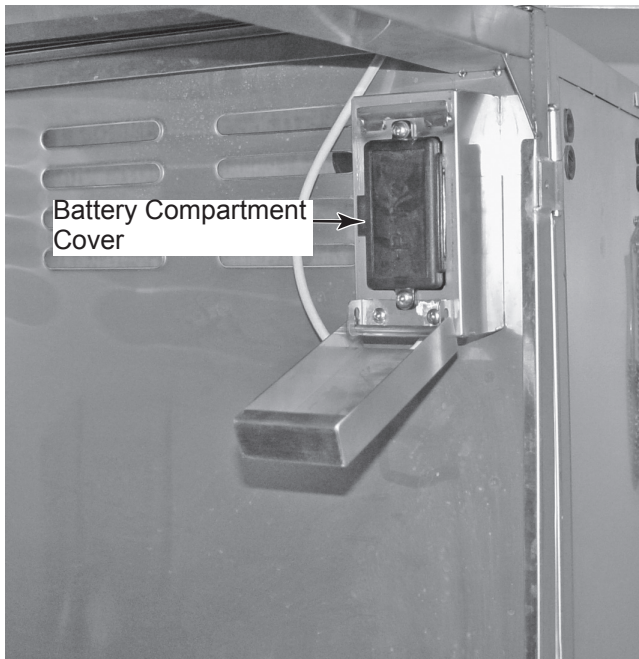

c) Remove the battery from the holder.

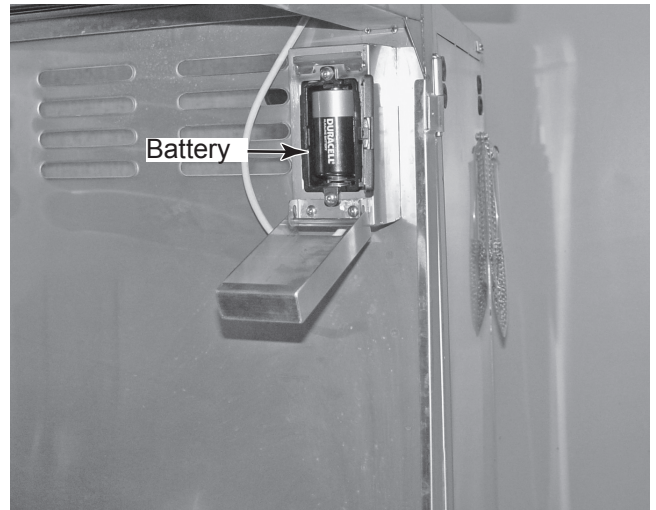

REMOVING A CABINET DOOR

1. To remove the cabinet door, open the door.
2. Lift the door straight up, and unhook the hinge pins from the hinge hangers.

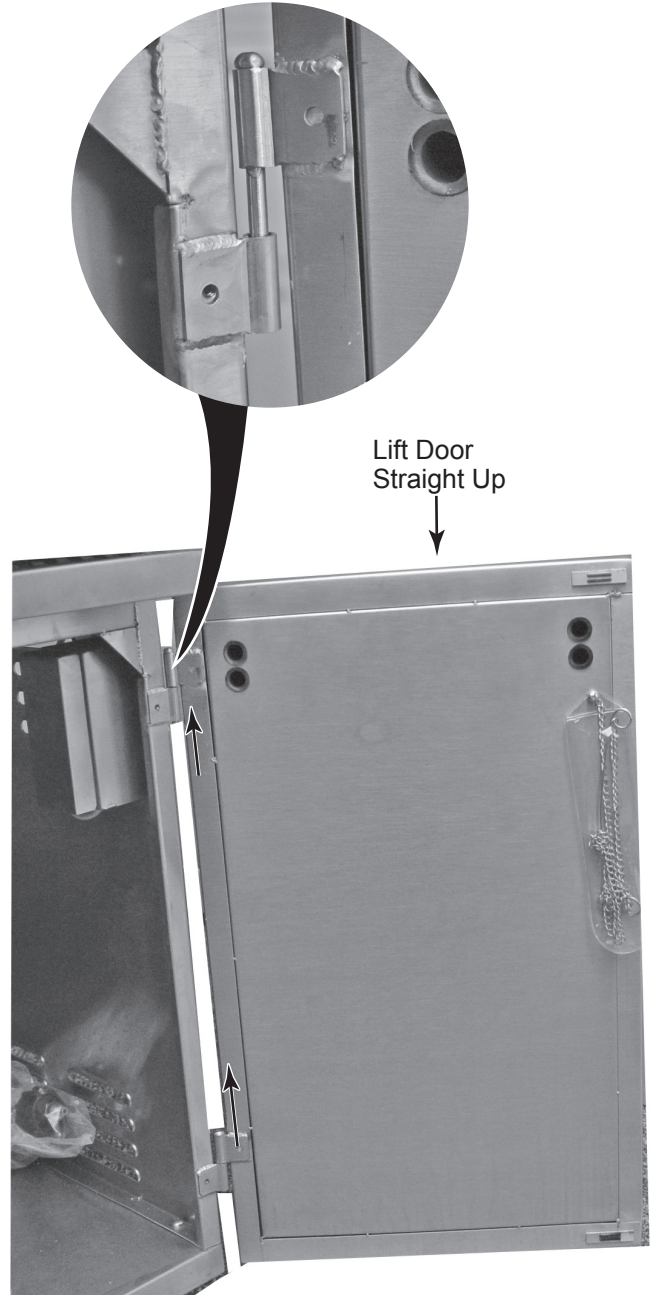

REMOVING TRANSFORMER

⚠ WARNING



Electrical Shock Hazard
Disconnect power before servicing.
Replace all parts and panels before operating.
Failure to do so can result in death or electrical shock.

1. Unplug grill or disconnect power.
2. Remove six screws from cover of transformer box.

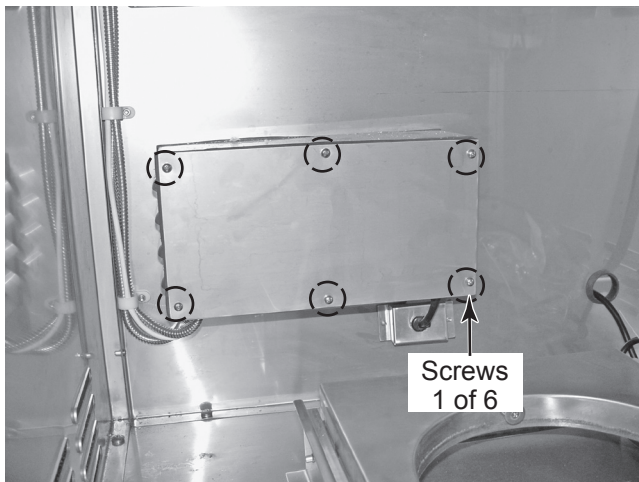

3. Disconnect two line voltage leads and red and white low voltage leads from transformer.

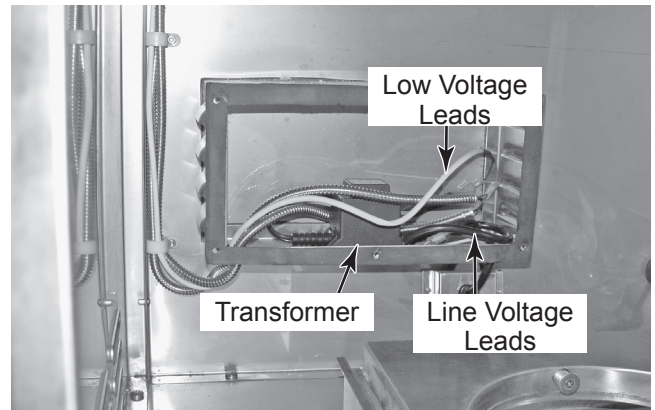

4. Remove four screws holding transformer to transformer box.

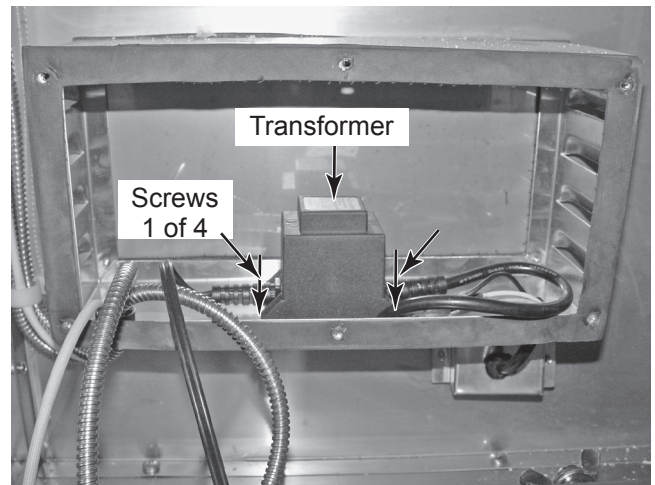

REMOVING GRILL LIGHT AND LIGHT SWITCH

⚠ WARNING



Electrical Shock Hazard

Disconnect power before servicing.

Replace all parts and panels before operating.

Failure to do so can result in death or electrical shock.

1. To remove grill light:

- a) Unplug grill or disconnect power.
- b) Remove hex head screw from light lens.

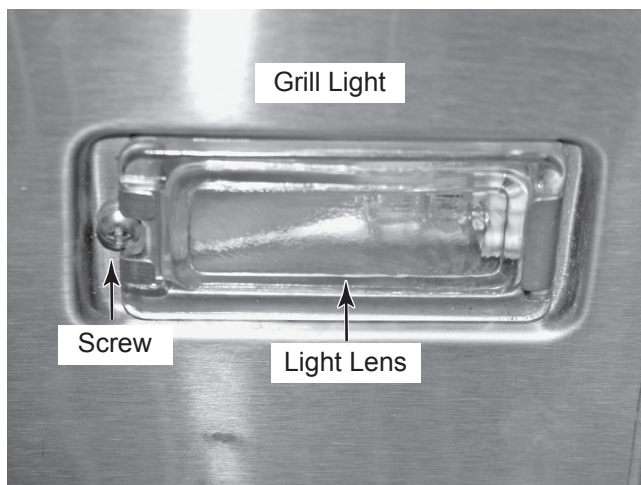

- c) Remove grill light from hood assembly.

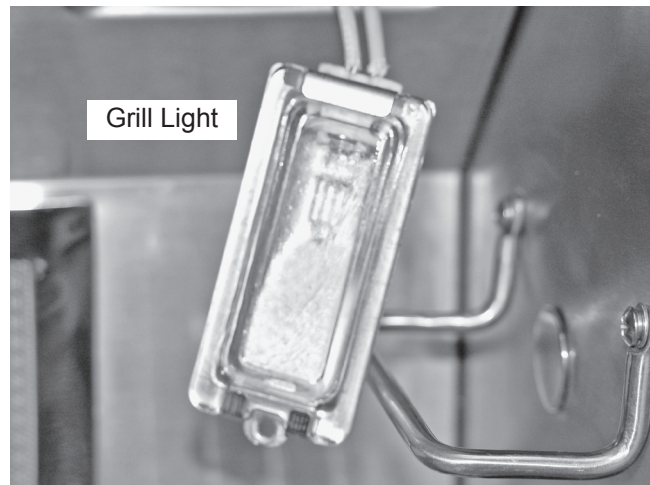

- d) Remove lens cover from grill light.
- e) Loosen two screws to release light bulb from grill light.

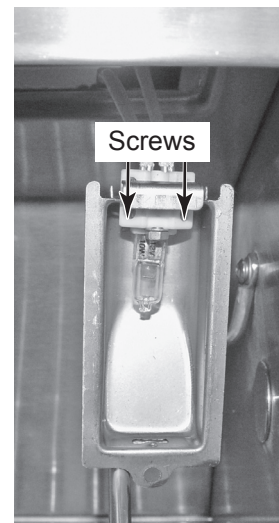

- d) Remove light bulb from grill light.

2. **To remove light switch:**

- a) Unplug grill or disconnect power.
- b) Remove the control panel (see page 4-2 for the procedure).
- c) Disconnect red and black wires from light switch.
- d) Loosen hex nut on light switch.

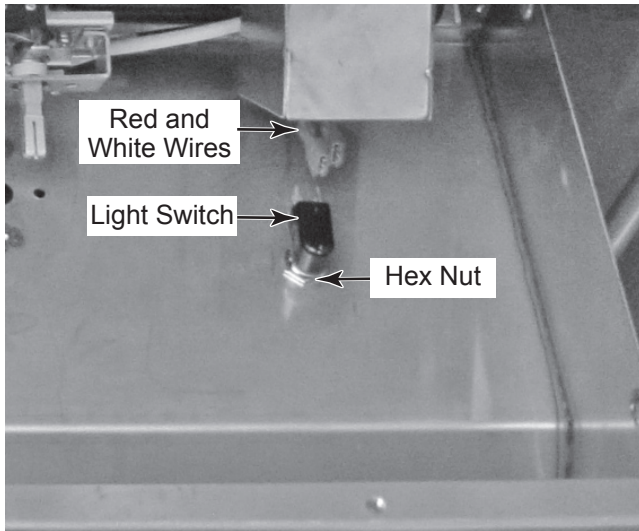

e) Loosen bezel nut on light switch.

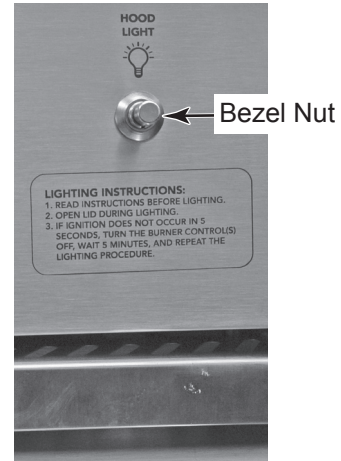

f) Remove light switch from control panel.

REMOVING WARMING DRAWER ASSEMBLY, WARMING DRAWER CONTROL, HEATING ELEMENT, AND SENSOR

! WARNING



Electrical Shock Hazard

Disconnect power before servicing.

Replace all parts and panels before operating.

Failure to do so can result in death or electrical shock.

1. To remove warming drawer assembly.

- a) Unplug grill or disconnect power.
- b) Pull the warming drawer out to the fully extended position.
- c) Push down or pull up release tabs on each drawer slide.

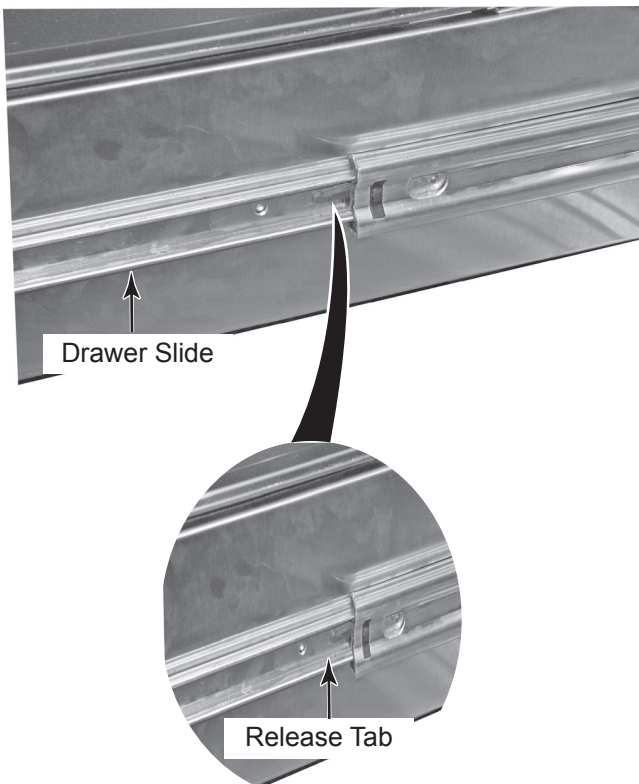

- d) Remove warming drawer from drawer slides in warming drawer assembly.
- e) Remove storage drawer above warming drawer using the same procedure as removing warming drawer.

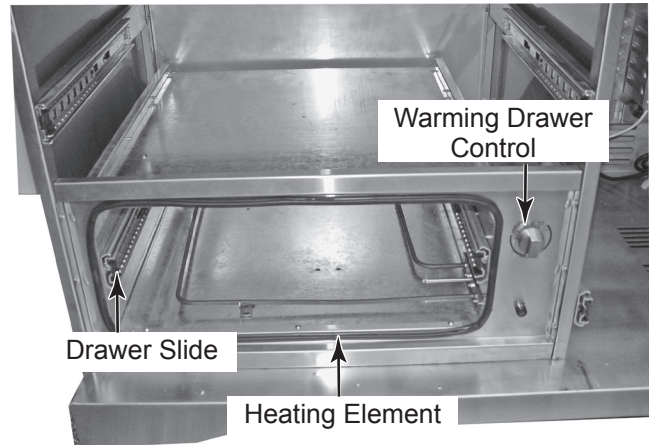

- f) Remove tank storage drawer to right of warming drawer using the same procedure as removing warming drawer.
- g) Remove screws from electrical access cover on right side of warming drawer assembly.

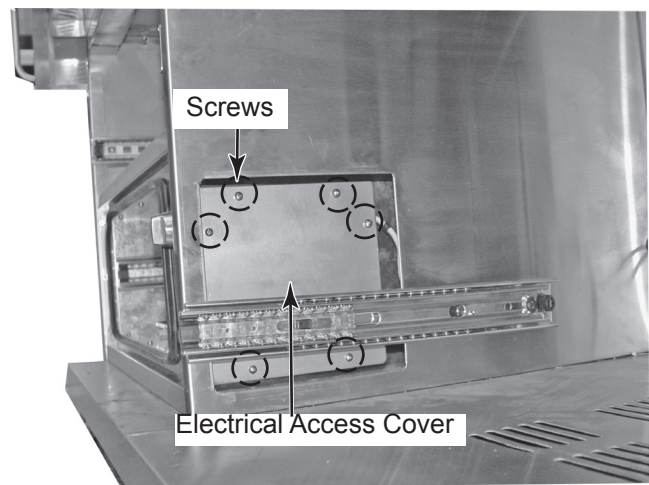

- g) Remove six screws from both sides of front of warming drawer and one screw behind electrical control box.

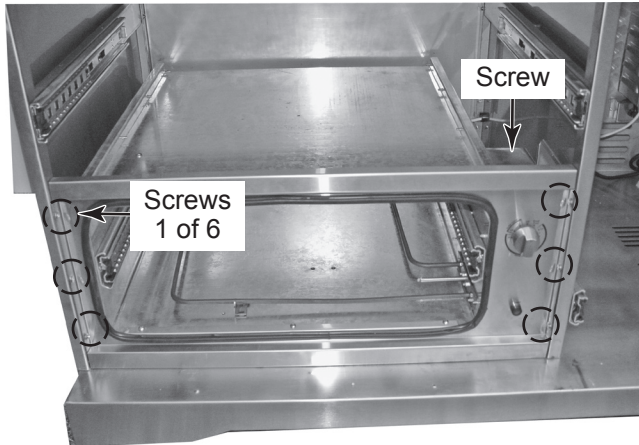

- i) Slide warming drawer assembly forward till side access cover is outside of unit.
j) Disconnect wiring harness from red and black connectors in electrical control box and unscrew grommet hex nut.

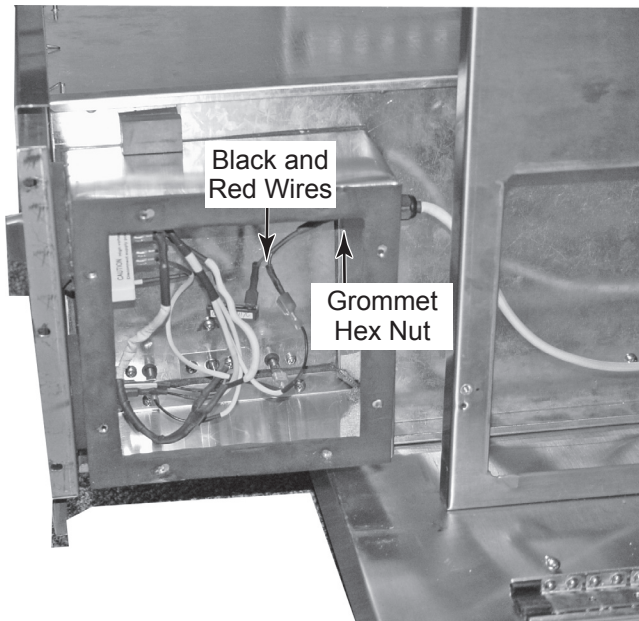

2. To remove warming drawer control.

- a) Unplug grill or disconnect power.
b) Remove the warming drawer assembly (see page 4-16 for the procedure).
c) Remove control knob and disconnect and remove control indicator light.
d) Remove six screws from inside edge of warming drawer.

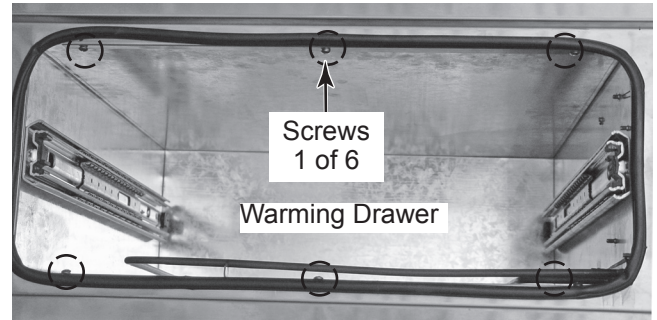

- e) Remove two screws from inside gasket that holds warming drawer control to electrical control box.

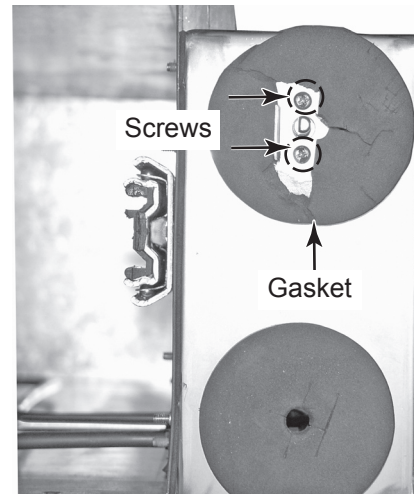

Continued on the next page.

- f) Disconnect control wires from warming drawer control.

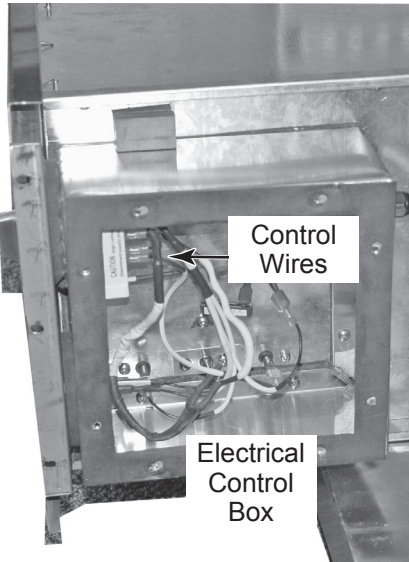

- d) Remove warming drawer from drawer slides in warming drawer assembly.
- e) Remove tank storage drawer to right of warming drawer using the same procedure as removing warming drawer.
- f) Remove screws from electrical access cover on right side of warming drawer assembly.

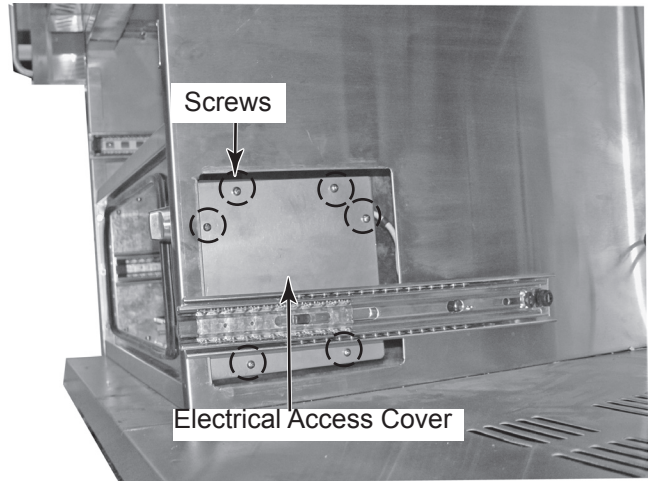

3. To remove heating element.

- a) Unplug grill or disconnect power.
- b) Pull the warming drawer out to the fully extended position.
- c) Push down or pull up release tabs on each drawer slide.

- g) Disconnect heating element wires from heating element.

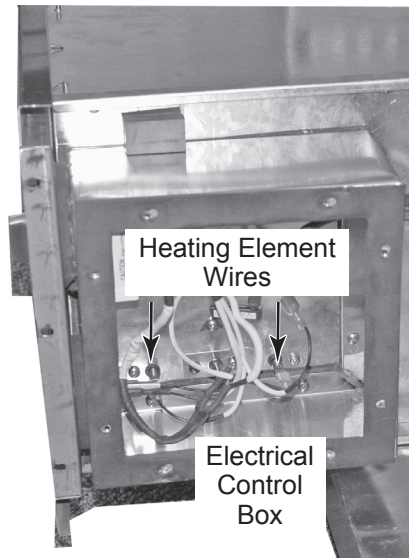
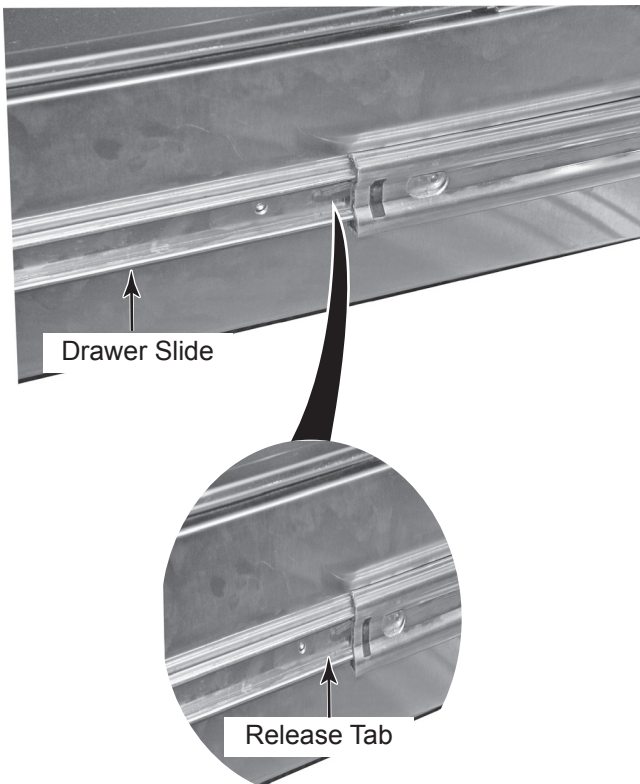

h) Remove two heating element screws from heating element.

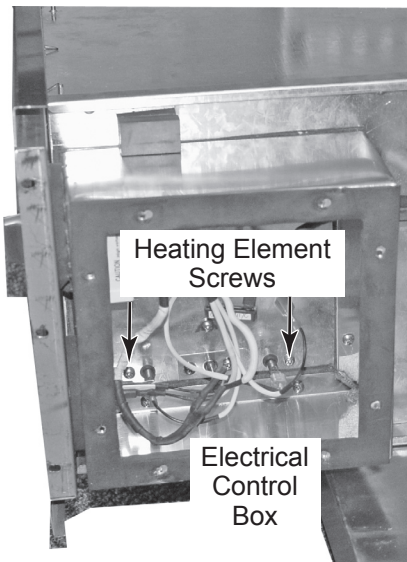

i) Remove heating element from warming drawer by sliding heating element feet out of slots and lift out of warming drawer.

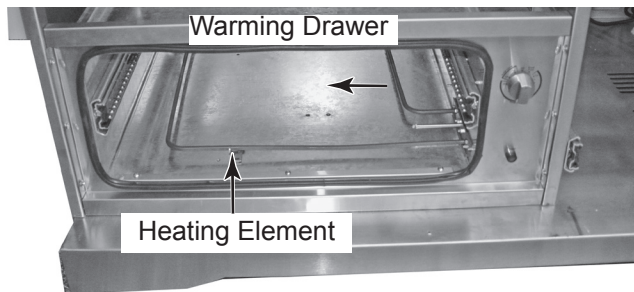

3. To remove sensor.

- a) Unplug grill or disconnect power.
- b) Pull the warming drawer out to the fully extended position.
- c) Push down or pull up release tabs on each drawer slide.

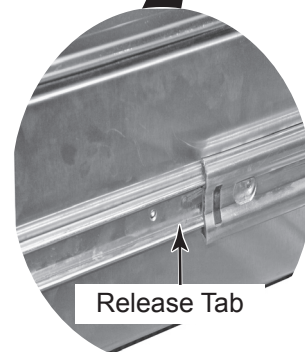
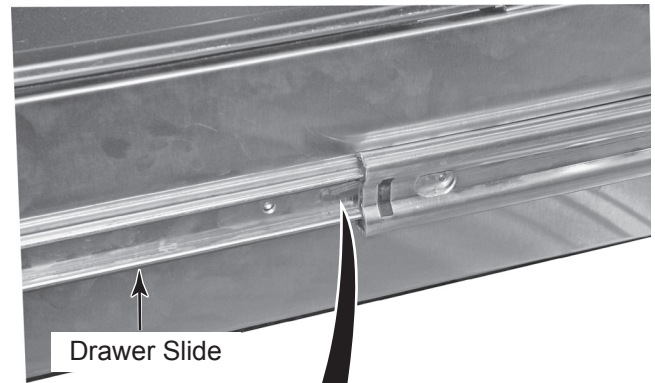

Continued on the next page.

- d) Remove warming drawer from drawer slides in warming drawer assembly.
- e) Remove tank storage drawer to right of warming drawer using the same procedure as removing warming drawer.
- f) Remove screws from electrical access cover on right side of warming drawer assembly.

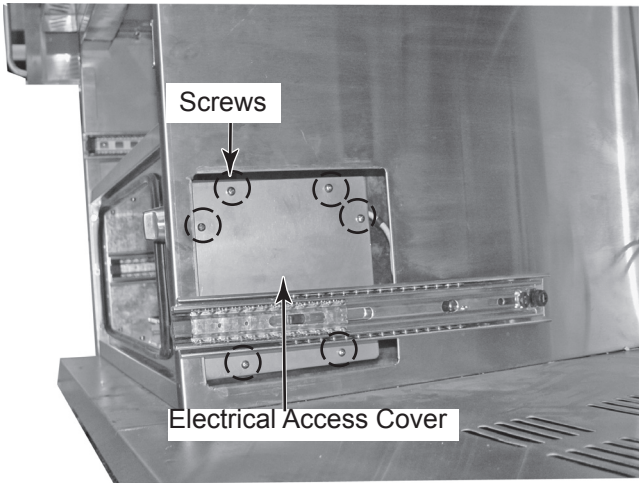

- g) Disconnect sensor wires from wire harness.

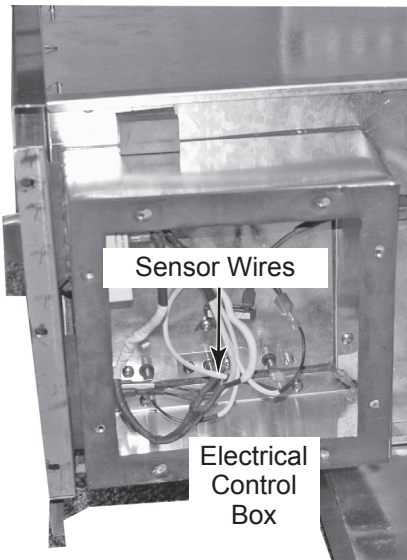

- h) Remove two sensor screws from sensor.

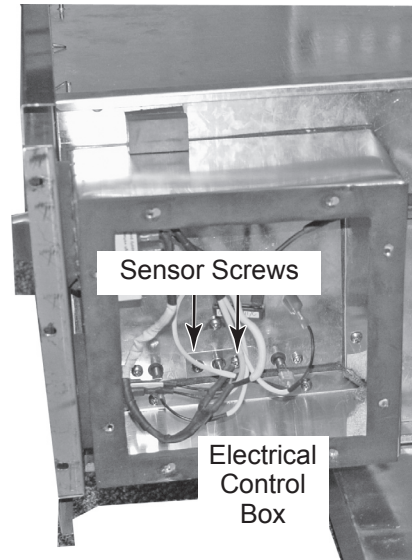

- i) Remove sensor from warming drawer by sliding sensor out of warming drawer.

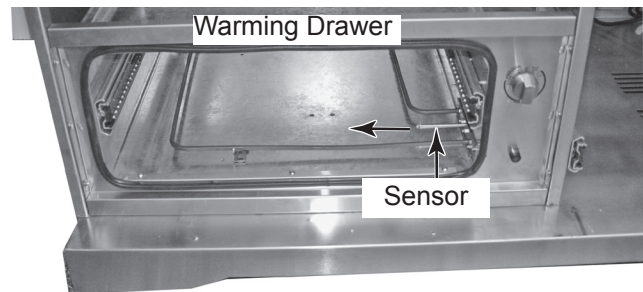

REMOVING A SIDE BURNER AND SIDE BURNER IGNITER

⚠ WARNING



Electrical Shock Hazard

Disconnect power before servicing.

Replace all parts and panels before operating.

Failure to do so can result in death or electrical shock.

1. Turn off and disconnect the gas supply going to the grill.
2. Remove the control panel (see page 4-2 for the procedure).
3. Remove four screws holding side burner to burner base.

4. Disconnect gas connector and igniter from side burner.
5. Remove burner from bottom burner base.

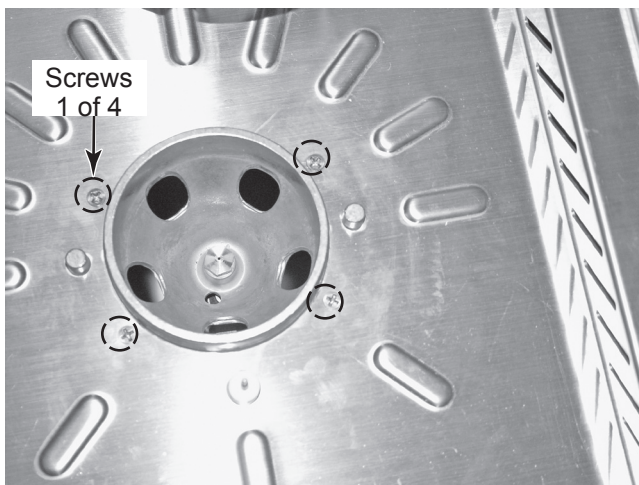
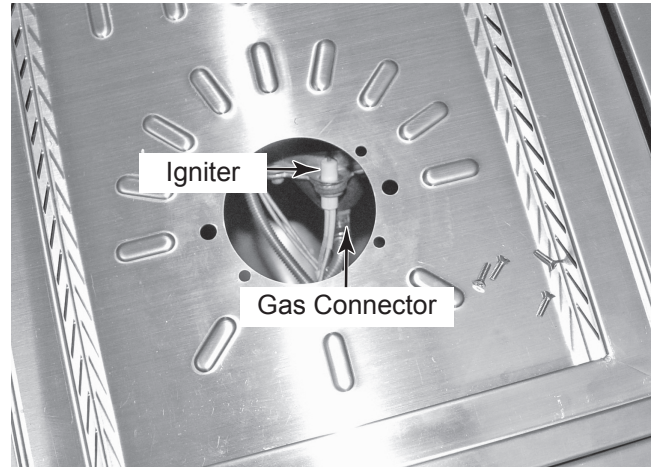

REMOVING A SEAR BURNER

1. Turn off and disconnect the gas supply going to the grill.
2. Remove the grates over sear burner.



3. Remove two screws holding rear of sear burner to burner box.

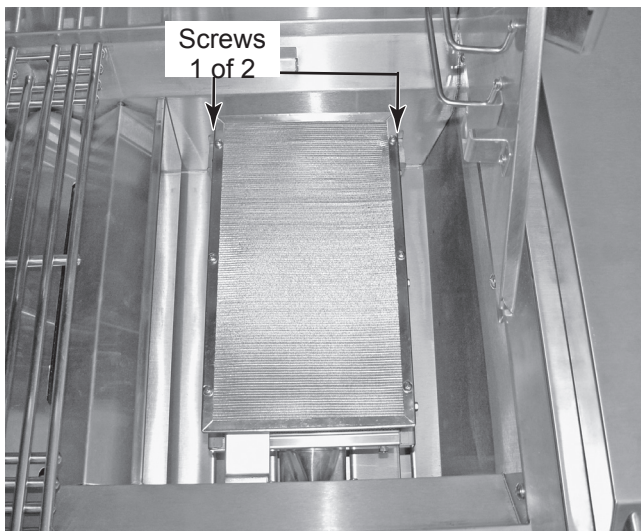

4. Lift rear of sear burner and pull out of burner box.

WIRING DIAGRAM

"S" STYLE MODEL WIRING DIAGRAM

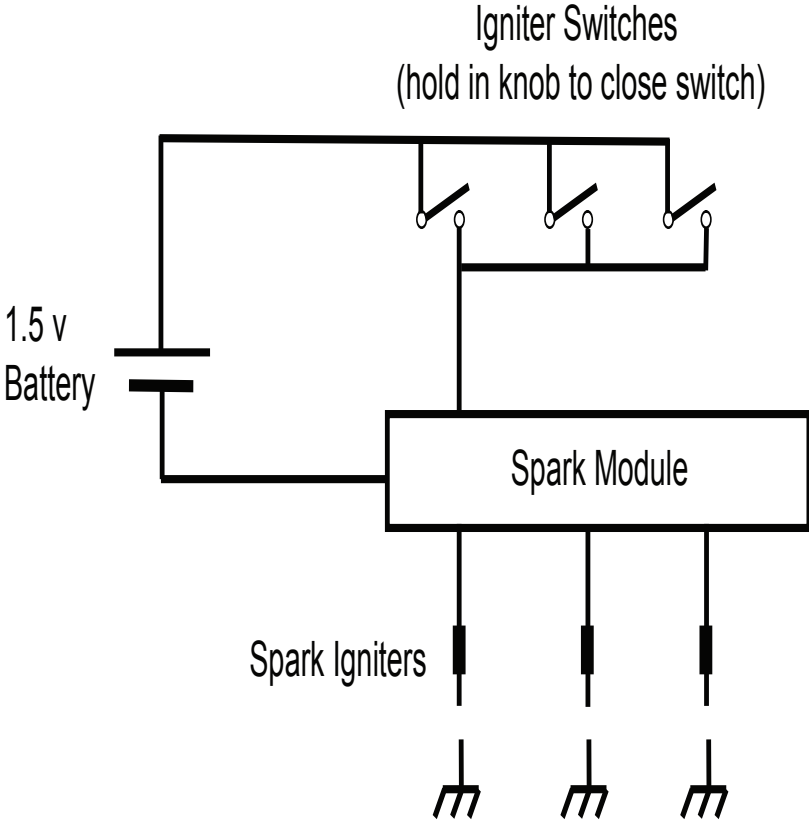

WIRING DIAGRAM

"U" STYLE MODEL WIRING DIAGRAM

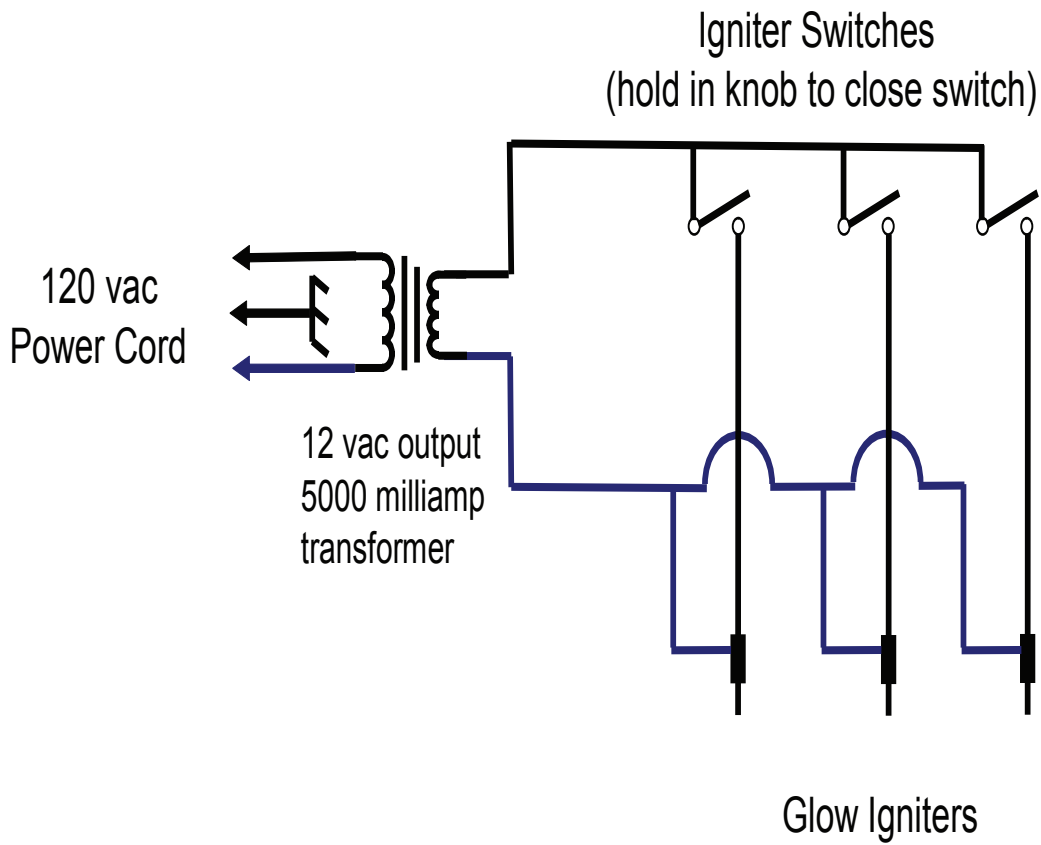

WIRING DIAGRAM

WARMING DRAWER WIRING DIAGRAM

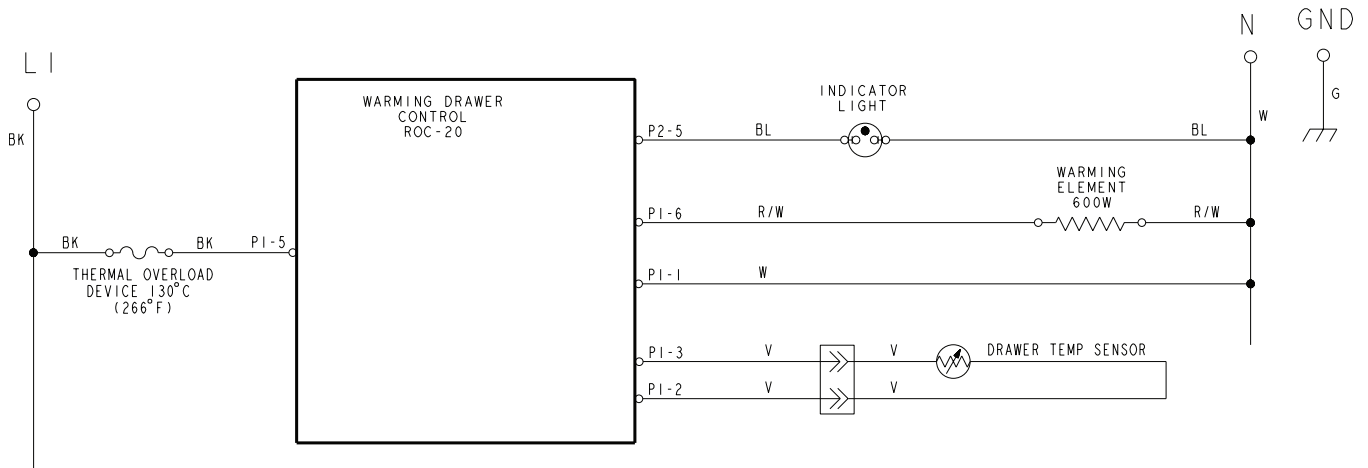

Notes:

1. Schematic shows switches in off condition and elements off.
2. When switch is "ON", element cycles ON/OFF for temperature control while indicator remains on continuously.

— NOTES —

PRODUCT SPECIFICATIONS AND WARRANTY INFORMATION SOURCES

IN THE UNITED STATES:

FOR PRODUCT SPECIFICATIONS AND WARRANTY INFORMATION CALL:

FOR WHIRLPOOL PRODUCTS: 1-800-253-1301
FOR KITCHENAID PRODUCTS: 1-800-422-1230
FOR ROPER PRODUCTS: 1-800-447-6737

FOR TECHNICAL ASSISTANCE WHILE AT THE CUSTOMER'S HOME CALL:

THE TECHNICAL ASSISTANCE LINE: 1-800-832-7174

**HAVE YOUR STORE NUMBER READY TO IDENTIFY YOU AS AN
AUTHORIZED IN-HOME SERVICE PROFESSIONAL**

FOR LITERATURE ORDERS:

PHONE: 1-800-851-4605

FOR TECHNICAL INFORMATION AND SERVICE POINTERS:

www.servicematters.com

IN CANADA:

FOR PRODUCT SPECIFICATIONS AND WARRANTY INFORMATION CALL:

1-800-461-5681

FOR TECHNICAL ASSISTANCE WHILE AT THE CUSTOMER'S HOME CALL:

THE TECHNICAL ASSISTANCE LINE: 1-800-488-4791

**HAVE YOUR STORE NUMBER READY TO IDENTIFY YOU AS AN
AUTHORIZED IN-HOME SERVICE PROFESSIONAL**

KitchenAid®
FOR THE WAY IT'S MADE.®