

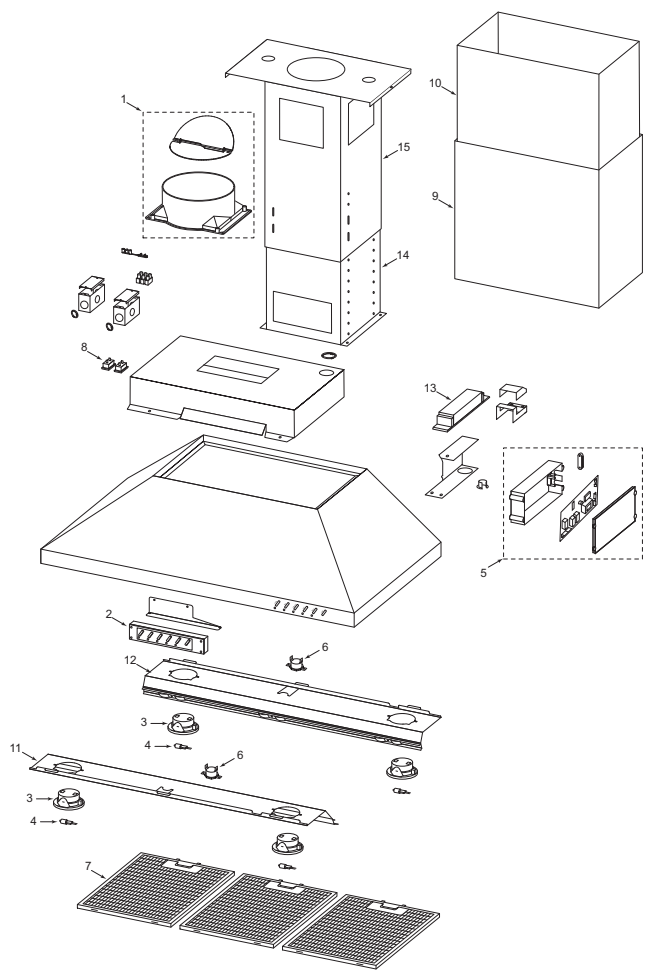

# CT & CTE HOODS DD & ICBDD VENTILATION

(Including Parts Lists and Exploded Views)

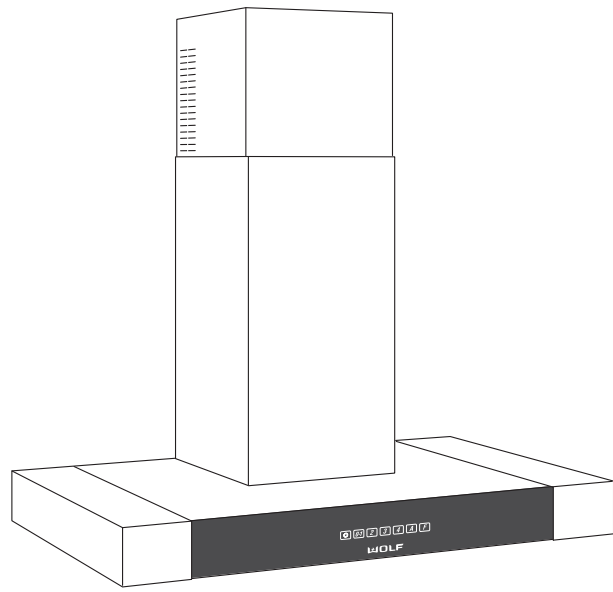

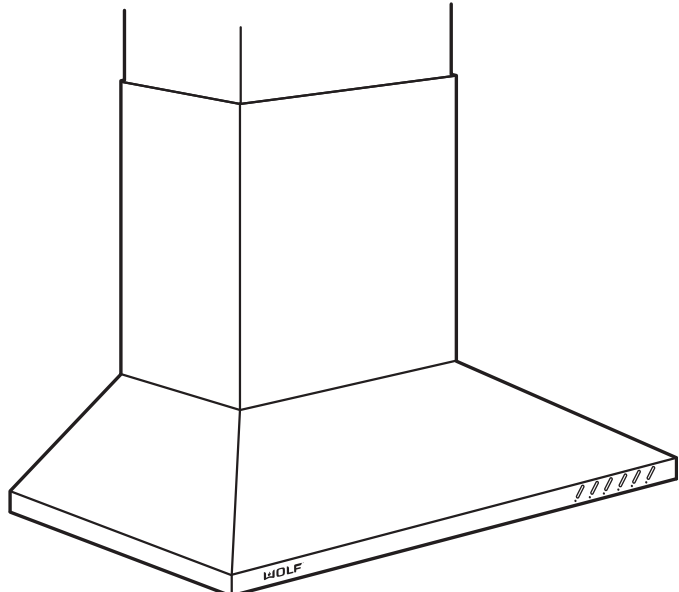

# SECTION 1

# GENERAL INFORMATION

**INTRODUCTION**

This Wolf Cooktop and Downdraft Ventilation Technical Service Manual, has been compiled with information provided by Broan-Nu Tone LLC. This manual provides the most recent technical service information that will enable the service technician to troubleshoot and diagnose malfunctions, perform necessary repairs and return a Wolf Ventilation product to proper operational condition.

The service technician should read the complete instructions contained in this Service Manual before initiating any repairs on a Wolf Appliance.

**IMPORTANT SAFETY INFORMATION**

Below are the Product Safety Labels used in this manual.

The “Signal Words” used are **WARNING** & **CAUTION**.

Please note that these safety labels are placed in areas where awareness of personal safety and product safety should be taken and lists the precautions to be taken when the signal word is observed.

**⚠ WARNING**  
**INDICATES THAT HAZARDOUS OR UNSAFE PRACTICES COULD RESULT IN SEVERE PERSONAL INJURY OR DEATH**

**⚠ CAUTION**  
**Indicates that hazardous or unsafe practices could result in minor personal injury or product and/or property damage**

In addition, please pay attention to the signal word “**NOTE**”, which highlights especially important information within each section.

**TECHNICAL ASSISTANCE**

If you should have any questions regarding a Wolf appliance and/or this manual, please contact:

Wolf Appliance, Inc.  
 ATTN.: Service Department  
 P.O. Box 44988  
 Madison, WI 53744-4988

Customer Service  
 Phone #: (800) 332 - 9513

Technical Assistance  
 Phone #: (800) 919 - 8324

Parts / Warranty Claims  
 Phone #: (800) 332 - 9513

Customer Service E-mail Address  
[customerservice@wolfappliance.com](mailto:customerservice@wolfappliance.com)

Customer Service & Technical Assistance  
 Facsimile #: (608) 441 - 5887

Parts / Warranty Claims  
 Facsimile #: (608) 441 - 5886

Office Hours:  
 7:00 AM to 7:00 PM Central Standard Time  
 Monday through Friday

**This manual is designed to be used by Authorized Service Personnel only. Wolf Appliance, Inc. assumes no responsibility for any repairs made to Wolf appliances by anyone other than Authorized Service Technicians.**

*The information and images contained in this manual are the copyright property of Wolf Appliance, Inc., an affiliate of Sub-Zero, Inc. Neither this manual nor any information or images contained herein may be copied or used in whole or in part without the express written permission of Wolf Appliance, Inc., an affiliate of Sub-Zero, Inc. © Wolf Appliance, Inc., all rights reserved.*

**TABLE OF CONTENTS**

Page #

	<i>Page #</i>		
<b>Section 1 - General Information</b> .....	1-1	<b>Section 4 - Access and Removal</b> (continued)	
Introduction .....	1-2	<b>CTE Hoods:</b>	
Important Safety Information .....	1-2	Bulb Removal .....	4-7
Technical Assistance .....	1-2	Filter Removal .....	4-7
Table of Contents .....	1-3	Inside Panel .....	4-7
Warranty Information .....	1-4	Lamp Socket .....	4-8
Model Descriptions .....	1-5	Control Panel Removal .....	4-8
		Internal Blower Removal .....	4-9
<b>Section 2 - Installation Information</b> .....	2-1	Control Board Removal .....	4-10
CT & Island Hood Overall Dimensions .....	2-2	<b>Downdrafts:</b>	
CTEWH Overall Dimensions .....	2-3	Filter Removal .....	4-11
CTEIH Overall Dimensions .....	2-4	Internal Blower Removal .....	4-12
CT Hood Placement .....	2-5	Cam Switch Removal .....	4-13
CT Wall Hood Installation Considerations .....	2-6	Front Air Box Removal .....	4-13
CT Wall Hood Installation .....	2-7	Gear Motor Removal .....	4-14
Ductwork Installation .....	2-8	Power Control Board Removal .....	4-15
Island Hood Installation Considerations .....	2-9	<b>Section 5 - Troubleshooting</b> .....	5-1
Island Hood Installation .....	2-10	Ventilation Troubleshooting Chart .....	5-3
Hood Internal Blower Installation .....	2-12	Downdraft Troubleshooting Chart .....	5-4
CTE Hood Installation Considerations .....	2-13	Low Profile Troubleshooting Chart .....	5-5
CTEW Hood Installation Specifications .....	2-14	Downdraft Cam Switch Operation .....	5-6
CTEW Hood Electrical Requirements .....	2-15	Downdraft Seal Damage Flow Chart .....	5-7
CTEW Hood Installation .....	2-15	<b>Section 6 - Technical Data</b> .....	6-1
CTEI Hood Installation Specifications .....	2-17	Voltage and Temperature Parameters (CT & DD) ....	6-2
CTEI Hood Electrical Requirements .....	2-18	Voltage Parameters (CTE) .....	6-3
CTEI Hood Installation .....	2-18	<b>Section 7 - Wiring Diagram</b> .....	7-1
Hood Remote Blower Installation .....	2-20	CTWH30 Wiring Diagram .....	7-2
Downdraft Dimensions .....	2-21	CTWH36 Wiring Diagram .....	7-3
Downdraft Installation Specifications .....	2-22	IH4227 Wiring Diagram .....	7-4
Downdraft Installation Requirements .....	2-23	Low Profile Hood Wiring Diagram .....	7-5
Downdraft Ducting Considerations .....	2-24	Downdraft Schematic .....	7-6
Downdraft Blower Discharge .....	2-25	Downdraft Wiring Diagram .....	7-7
Downdraft Installation .....	2-25	ICBDD Schematic .....	7-8
DD Internal Blower Installation .....	2-26	ICBDD Wiring .....	7-9
DD Remote Blower Installation .....	2-26	Downdraft Control Schematic .....	7-10
<b>Section 3 - Controls &amp; Operation</b> .....	3-1	Downdraft Power Supply Wiring .....	7-11
Electronic Control for CT Wall Hoods .....	3-2	CT & IH Hood Power Supply Wiring .....	7-12
Heat Sentry Mode .....	3-2	Blower Wiring .....	7-13
Electronic Control for Downdraft .....	3-3	<b>Section 8 - Parts List and Exploded Views</b> .....	8-1
Cleaning .....	3-3	CT Hood Parts List .....	8-2
Electronic Control for Low Profile Hoods .....	3-4	CT Hood Exploded View .....	8-3
<b>Section 4 - Access and Removal</b> .....	4-1	IH4227 Parts List .....	8-4
<b>CT Hoods:</b>		IH4227 Exploded View .....	8-5
Filter Removal .....	4-2	CTEWH30I, 36I, 45I Parts List .....	8-6
Bulb and Light Assembly .....	4-3	CTEWH30I, 36I, 45I Exploded View .....	8-7
Heat Sentry .....	4-4	CTEWH36, 45 Parts List .....	8-8
Control Interface .....	4-4	CTEWH36, 45 Exploded View .....	8-9
Power Outlet .....	4-5	CTEIH42 Parts List .....	8-10
Transformer .....	4-6	CTEIH42 Exploded View .....	8-11
Fuse .....	4-6	Downdraft Parts List .....	8-12
		Downdraft Exploded View .....	8-13
		ICBDD Parts List .....	8-14
		ICBDD Exploded View .....	8-15

**WARRANTY INFORMATION**

This page contains a summary of the Warranty supplied with every Domestic Wolf ventilation product, followed by details about the warranty.

**NOTE:** "ICB" warranties vary by Country and Distributor. Contact selling Distributor for warranty coverage.

**2 & 5 YEAR WARRANTY SUMMARY**

- 2 YEAR TOTAL PRODUCT WARRANTY, Parts and Labor.
- 3-5 LIMITED \*PARTS ONLY WARRANTY (Including Blower motors).

**DETAILS:**

- Warranty applies to products installed in United States or Canada, for residential use only.
- Warranty begins at time of unit's initial installation.
- This Warranty does not cover Wolf Appliances installed in a demonstration kitchen, test kitchen, culinary school kitchen, or similar installations. (See Special Warranty below)
- Warranty and Service information collected by Wolf Appliance, Inc. is arranged and stored under unit serial number and/or customer's name. Please note that Wolf Appliance, Inc requests that you have model and serial number available whenever contacting factory or parts distributor.

**SPECIAL WARRANTY SUMMARY**

- 2 YEAR TOTAL PRODUCT WARRANTY, Part and Labor.

**DETAILS:**

- This Warranty applies to products installed in United States or Canada, for use in a demonstration kitchen, test kitchen, culinary school kitchen, and similar installations that will help promote Wolf Appliance brand and its products.
- Warranty begins at time of unit's initial installation.
- Warranty and Service information collected by Wolf Appliance, Inc. is arranged and stored under unit serial number and/or customer's name. Please note that Wolf Appliance, Inc. requests that you have model and serial number available whenever contacting factory or parts distributor.

**INFORMATION PLATE AND SERIAL NUMBER**

- See Figure 1-1 for typical Information Plate layout.
- See Figures 1-2 & 1-3 for Serial Number location.

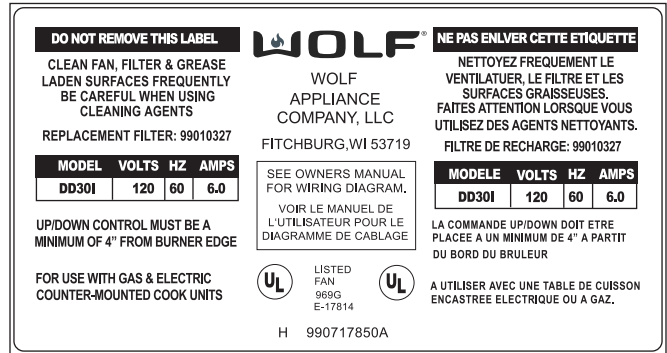

Figure 1-1 Serial Plate Layout

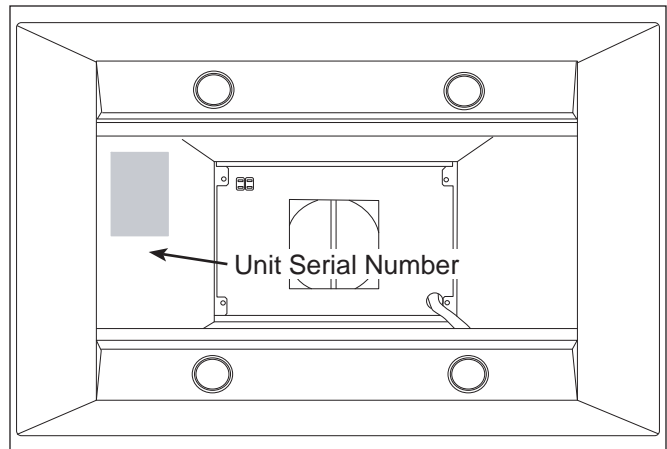

Figure 1-2 Serial Plate Location (CT Hoods)

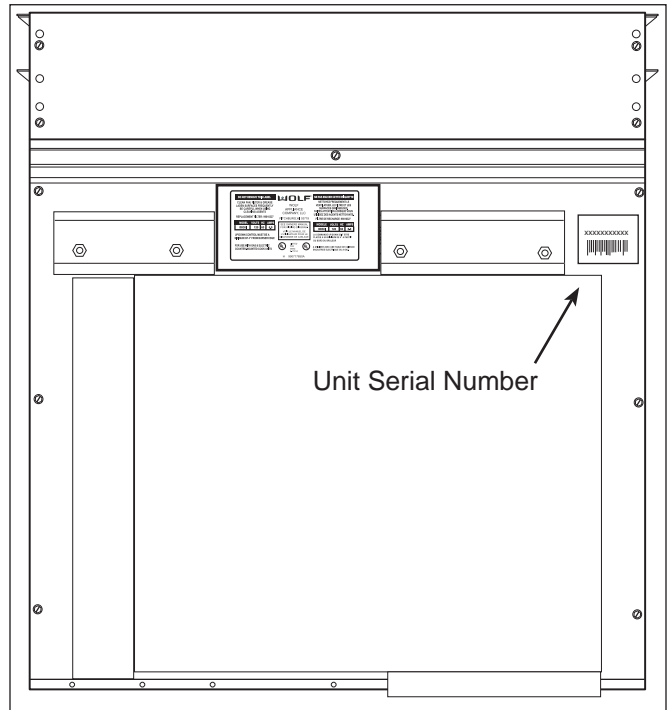
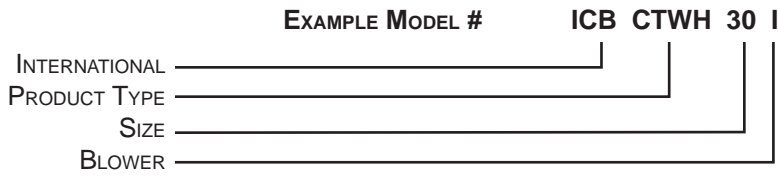

Figure 1-3 Serial Plate Location (DD Ventilation)

### MODEL DESCRIPTIONS

This section explains the model numbering system for the CT Hoods and Downdraft models covered in this manual.



#### PRODUCT TYPE

- CTWH**    COOKTOP (OR CHIMNEY) WALL HOOD
- CTEWH**   COOKTOP (OR CHIMNEY) LOW PROFILE WALL HOOD
- CTEIH**    COOKTOP (OR CHIMNEY) LOW PROFILE ISLAND HOOD
- IH**        ISLAND HOOD
- DD**        DOWN DRAFT

#### SIZE

- 30**        30 INCH WIDE UNIT
- 36**        36 INCH WIDE UNIT
- 42**        42 INCH WIDE X 27 INCH DEEP  
(ONLY ON ISLAND HOOD)
- 45**        45 INCH WIDE UNIT  
(ONLY ON DOWN DRAFT)

#### BLOWER TYPE

- I**         INTERNAL BLOWER
- R**         REMOTE BLOWER





SECTION 2  
INSTALLATION  
INFORMATION

**CT & ISLAND HOOD OVER-ALL DIMENSIONS**

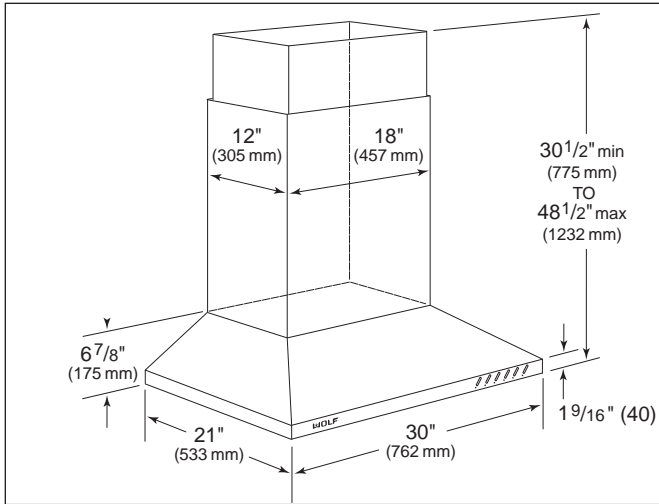

**MODEL CTWH30**

Overall Width	30" (762)
Overall Height (excluding chimney)	6 <sup>7</sup> / <sub>8</sub> " (175)
Overall Height (including chimney)	30 <sup>1</sup> / <sub>2</sub> " (775)
Max Height (full extension)	48 <sup>1</sup> / <sub>2</sub> " (1232)
Overall Depth	21" (533)
Shipping Weight (shell only)	85 lbs (39 kg)
Dimensions may vary to ± <sup>1</sup> / <sub>8</sub> " (3).	

Figure 2-1 CTWH30 Dimensions

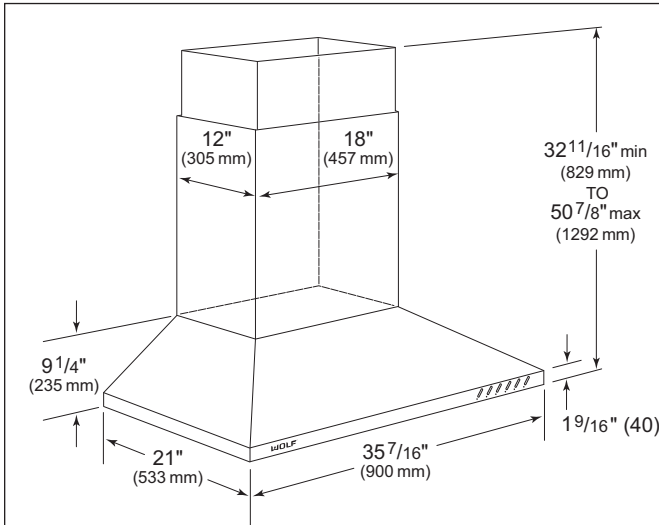

**MODEL CTWH36**

Overall Width	35 <sup>7</sup> / <sub>16</sub> " (900)
Overall Height (excluding chimney)	9 <sup>1</sup> / <sub>4</sub> " (235)
Overall Height (including chimney)	32 <sup>11</sup> / <sub>16</sub> " (830)
Max Height (full extension)	50 <sup>7</sup> / <sub>8</sub> " (1292)
Overall Depth	21" (533)
Shipping Weight (shell only)	100 lbs (45 kg)
Dimensions may vary to ± <sup>1</sup> / <sub>8</sub> " (3).	

Figure 2-2 CTWH36 Dimensions

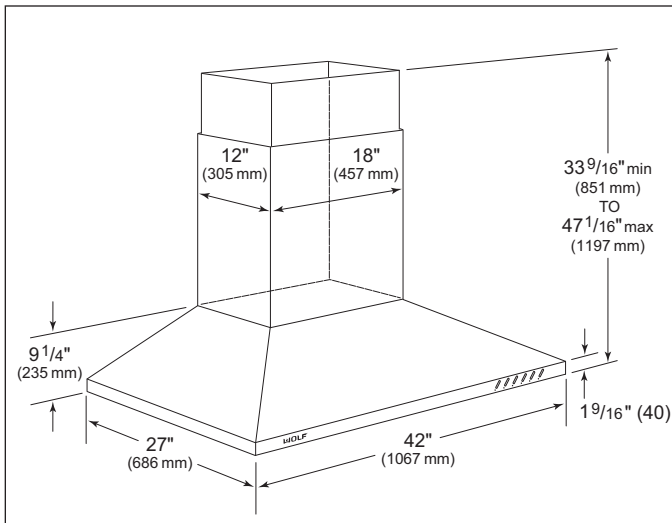

**MODEL IH4227**

Overall Width	42" (1067)
Overall Height (excluding chimney)	9 <sup>1</sup> / <sub>4</sub> " (235)
Overall Height (including chimney)	33 <sup>9</sup> / <sub>16</sub> " (853)
Max Height (full extension)	47 <sup>1</sup> / <sub>16</sub> " (1195)
Overall Depth	27" (686)
Shipping Weight (shell only)	110 lbs (50 kg)
Dimensions may vary to ± <sup>1</sup> / <sub>8</sub> " (3).	

Figure 2-3 IH4227 Dimensions

## CTEW HOOD OVER-ALL DIMENSIONS

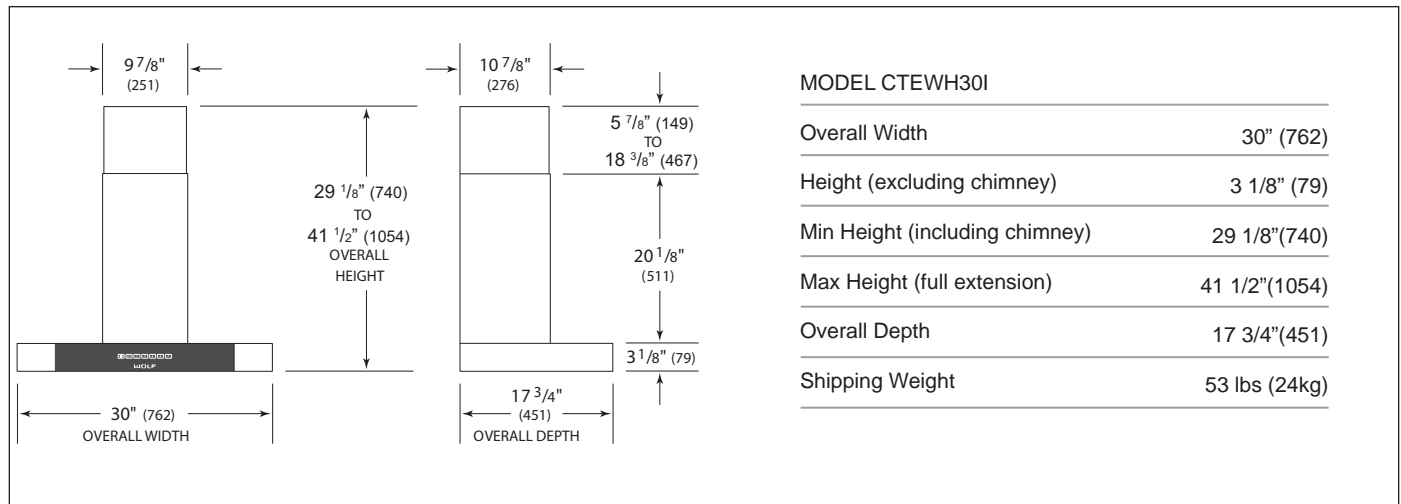

Figure 2-4 CTEWH30 Dimensions

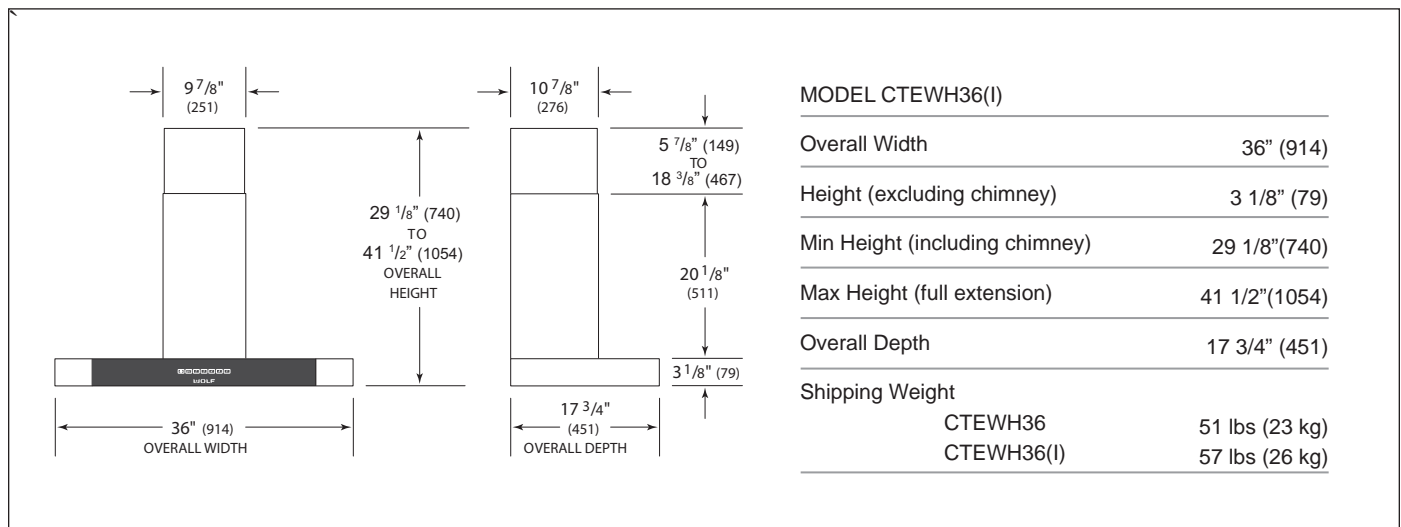

Figure 2-5 CTEWH36 Dimensions

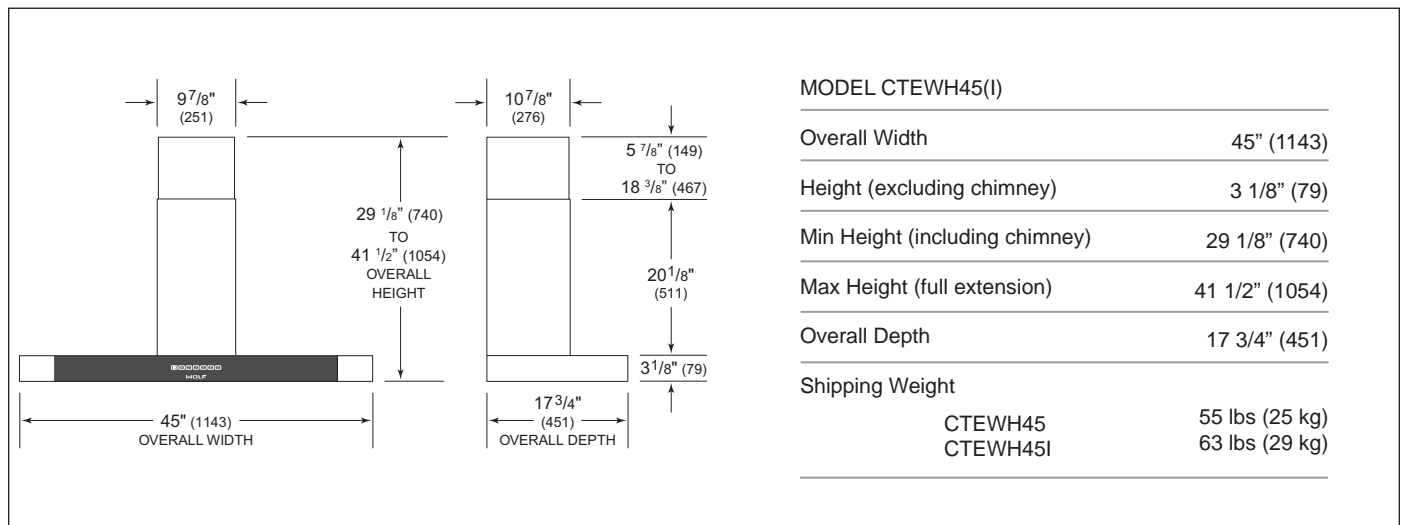
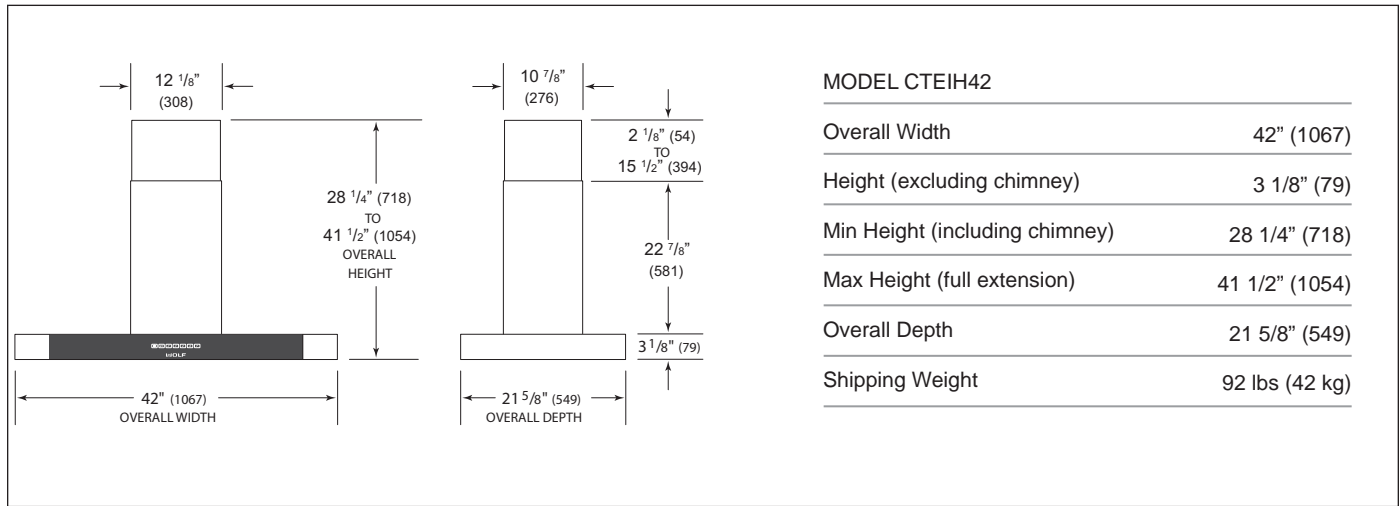

Figure 2-6 CTEWH45 Dimensions

**CTEI Hood OVER-ALL DIMENSIONS**



MODEL CTEIH42	
Overall Width	42" (1067)
Height (excluding chimney)	3 1/8" (79)
Min Height (including chimney)	28 1/4" (718)
Max Height (full extension)	41 1/2" (1054)
Overall Depth	21 5/8" (549)
Shipping Weight	92 lbs (42 kg)

Figure 2-7 CTEIH42 Dimensions

## HOOD PLACEMENT

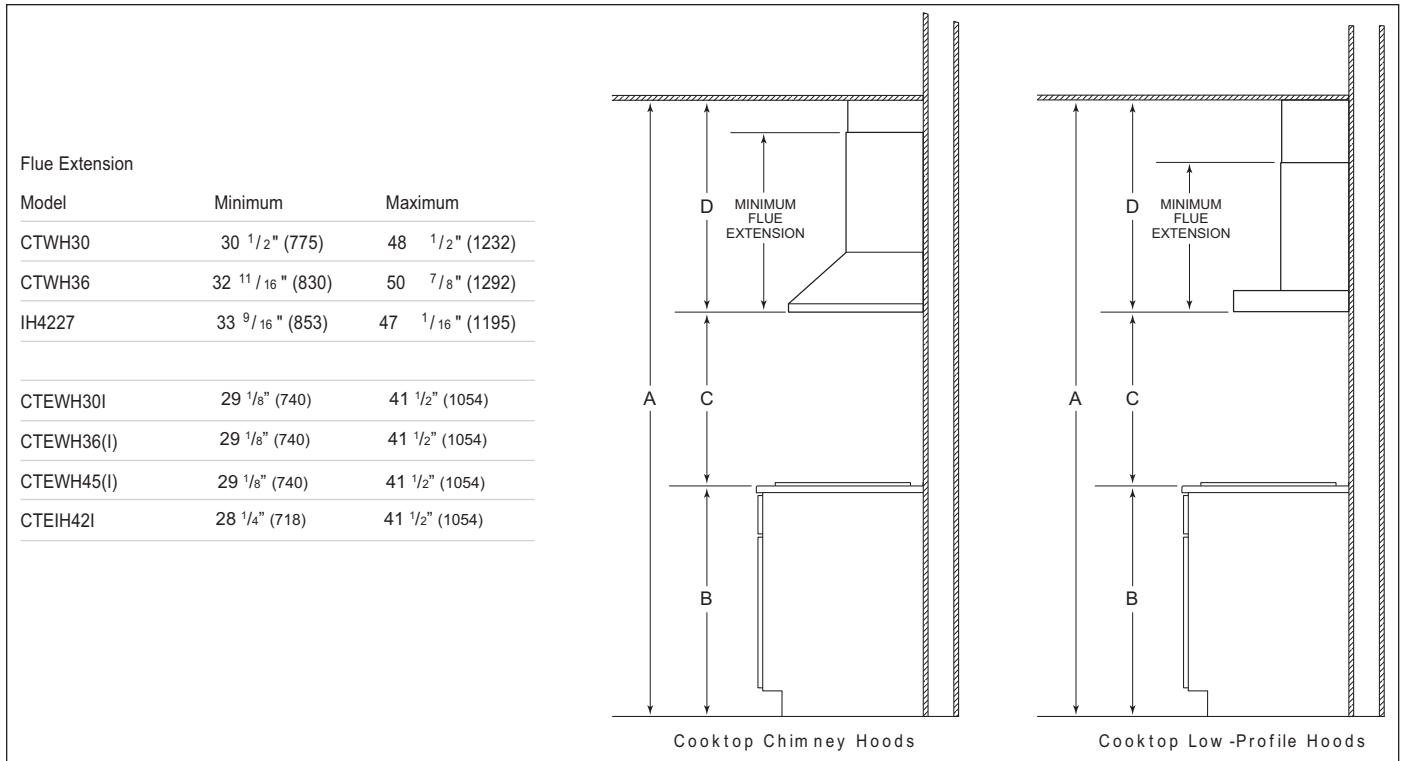

Figure 2-8 Hood Placement Dimensions

### HOOD PLACEMENT

Wolf cooktop wall and island hoods come with a telescopic chimney flue that allows you to reach ceiling heights of 8' (2.4m) to 9' (2.7m) with a finished look. A flue extension to accommodate 10' (3m) ceilings is available as a sales accessory for cooktop chimney hoods only.

Installation of the cooktop wall or island hood should be 24" (610) to 30" (762) from the bottom of the hood to the countertop.

To determine placement of the wall or island hood, you must calculate the heights of the telescopic chimney flue. Refer to the chart in Figure 2-8 above for the minimum and maximum flue extension for specific hood.

**NOTE:** Both sections of the telescopic chimney flue must be installed in order for the chimney to be lifted for service.

**NOTE:** If the height of the upper flue section is less than 1/2" (13), you will need to modify the flue to affix to the flue attachment brackets.

### CALCULATING CHIMNEY FLUE HEIGHT

1. Measure A (total kitchen height from finished floor to finished ceiling height).
2. Measure B (height from finished floor to countertop).
3. Determine the desired distance from counter-top to bottom of hood (C). This dimension must be between 24" (610) and 30" (762).

**NOTE:** 8' (2.4m) ceilings may not permit installation of the wall or island hood at 30" (762) above the countertop.

4. To calculate the chimney flue height (D):  $D = A - (B + C)$ . This dimension must be between the minimum and maximum flue extension for your specific hood as shown in the chart.

**CT WALL HOOD INSTALLATION CONSIDERATIONS**

**⚠ WARNING**  
**TO REDUCE THE RISK OF FIRE, USE ONLY RIGID METAL DUCTWORK.**

**⚠ CAUTION**  
**TO REDUCE THE RISK OF FIRE AND ELECTRIC SHOCK, THIS VENTILATION HOOD SHOULD ONLY BE INSTALLED WITH BLOWERS MANUFACTURED BY WOLF APPLIANCE INC. AND SPECIFIED FOR USE WITH THESE VENTILATION MODELS.**

**COUNTERTOP WALL HOODS INSTALLATION SPECIFICATIONS AND PREPARATIONS FOR MODELS CTWH30 & CTWH36**

1. A straight, short duct run will allow the hood to perform more efficiently. Limit the number of elbows and transitions to as few as possible. Long duct runs, elbows and transitions will reduce the performance of the hood.

**NOTE:** All hoods must exhaust to the outdoors.

**NOTE:** There is a possibility of noise issues, if a short duct run is coupled with a remote blower.

2. Always use metal ducting. Do not use flex ducting.
3. Wolf recommends installing a back-draft damper in all installations (included with hood). In cold weather installations a back-draft damper is necessary to minimize the back-flow of cold air into the room.
4. Wolf recommends the hood be installed 24" (610 mm) to 30" (762 mm) above the cooking surface.

**NOTE:** Local building codes may require the use of make-up air. Consult a local HVAC professional for specific requirements.

**ELECTRICAL REQUIREMENTS**

Wolf cooktop wall hoods require a separate, grounded, 110/120 VAC, 60 Hz power supply. The service should have its own 15 amp circuit breaker.

**NOTE:** You must follow all National Electrical Code regulations. In addition, be aware of local codes and ordinances when installing your service.

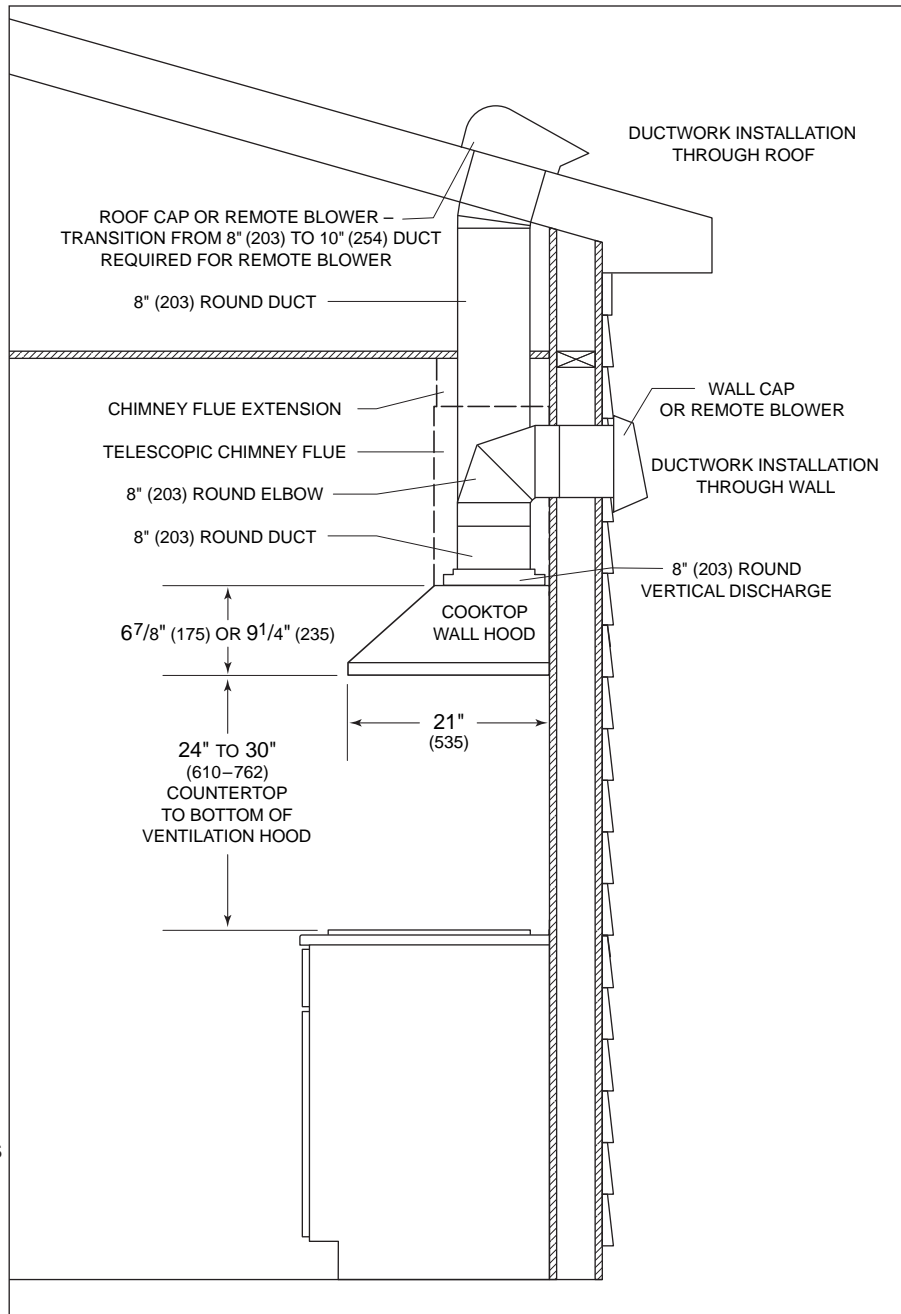

Figure 2-9 CT Wall Hood Installation Considerations

## CT WALL HOOD INSTALLATION

### ⚠ WARNING

**DUE TO THE WEIGHT OF SOME HOODS, SEVERAL PEOPLE MAY BE REQUIRED FOR A SAFE AND PROPER INSTALLATION.**

#### INSTALL MOUNTING BRACKETS

Construct wood wall framing that is flush with the interior surface of the wall studs. Make sure that the framing is centered in the hood installation location, and that the height of the framing will allow the mounting brackets to be secured to the framing within the dimension shown in Figure 2-10.

After the wall surface is finished, secure the mounting brackets to the framing using the dimensions shown.

#### INSTALL THE HOOD

Hang the hood from the brackets through the rectangular cut-outs on the back of the hood. The cut-outs are larger than the brackets to allow for vertical and horizontal adjustment. (See Figure 2-11)

Keep in mind that the bottom of the hood should be 24" (610) to 30" (762) above the countertop.

### ⚠ WARNING

**TO REDUCE THE RISK OF ELECTRICAL SHOCK, THIS VENTILATION HOOD MUST BE PROPERLY GROUNDED.**

Use height adjustment screws to adjust the hood vertically and the depth adjustment screws to adjust the hood horizontally.

Secure the hood with additional mounting screws. If wall studs or framing are not available in the proper location, use the drywall anchors provided with the hood.

#### ELECTRICAL CONNECTIONS

**NOTE:** This unit should be installed by a qualified electrician in accordance with all applicable national and local codes.

1. Remove the cover from the rear electrical box knockout that faces the hood's discharge collar.
2. Insert 6" (152) of 120 VAC power cable through the knockout opening. Secure the cable to the electrical box with an appropriate connector.
3. Make electrical connections. Connect black to black, white to white and green/yellow to green or bare wire. (See Figure 2-12)
4. Reinstall the electrical box cover and screws. Make sure that all wires are secure and that no wires are pinched between the cover and box.

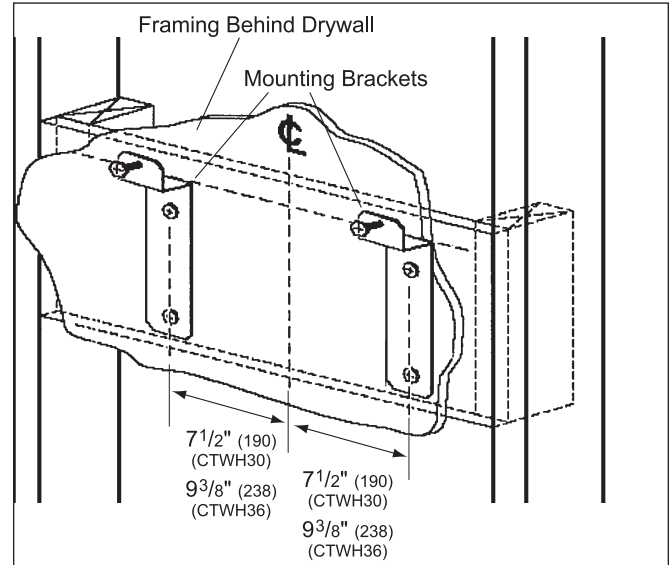

Figure 2-10 Mounting Bracket Installation

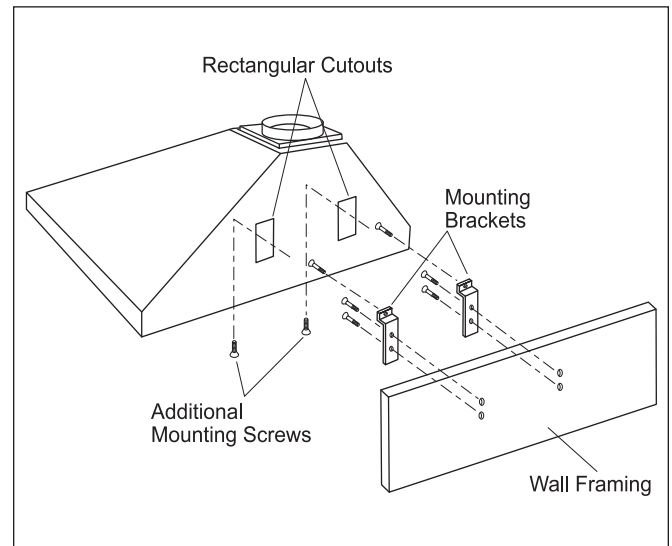

Figure 2-11 Hood Installation

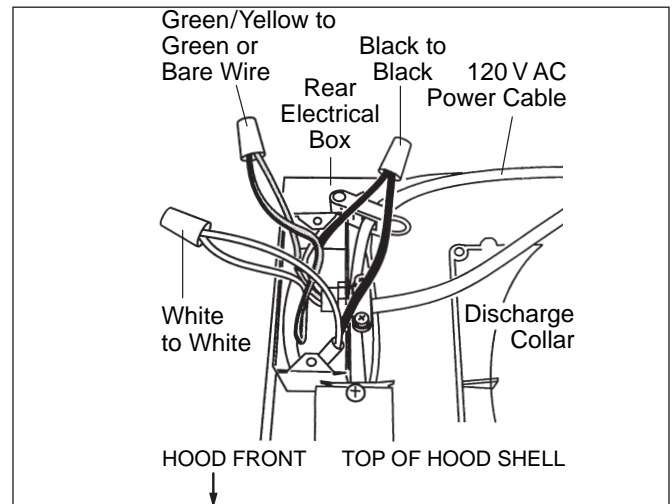

Figure 2-12 Electrical Connections

**CT WALL HOOD DUCTWORK INSTALLATION****CONNECT DUCTWORK**

Use the screws and wall anchors provided to secure the upper brackets to the ceiling. Position the upper brackets based on the dimension of the telescopic chimney flue.

(See Figure 2-13)

Use an 8" (203) round metal duct to connect the duct collar on the hood to the ductwork above. Use duct tape to make all joints secure and air tight.

Connect the upper section of the telescopic chimney flue to the brackets with the screws provided. (See Figure 2-14)

Nest the bottom of the telescopic chimney flue into the relief in the hood shell.

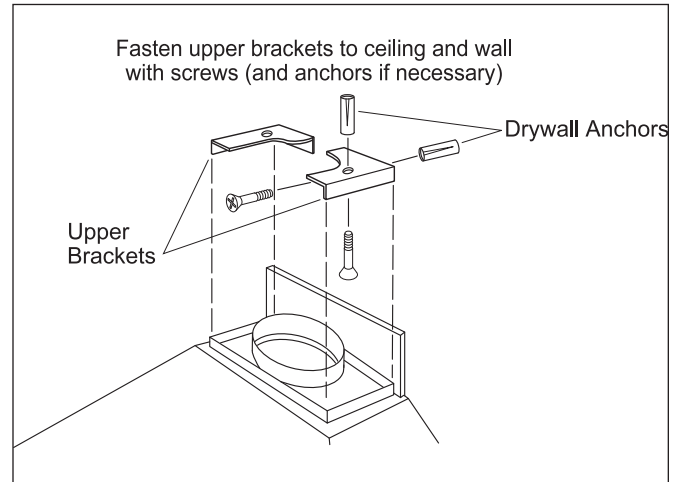

Figure 2-13 Upper Flue Bracket Installation

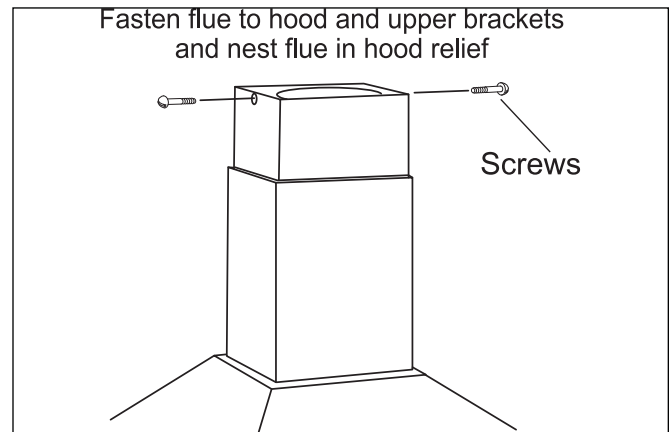

Figure 2-14 Securing Inner Flue to Upper Flue Bracket



## COOKTOP ISLAND HOOD INSTALLATION CONSIDERATIONS

### ⚠ WARNING

TO REDUCE THE RISK OF FIRE, USE ONLY METAL DUCTWORK.

### ⚠ CAUTION

TO REDUCE THE RISK OF FIRE AND ELECTRIC SHOCK, THIS VENTILATION HOOD SHOULD ONLY BE INSTALLED WITH BLOWERS MANUFACTURED BY WOLF APPLIANCE INC. AND SPECIFIED FOR USE WITH THESE VENTILATION MODELS.

### ISLAND HOOD INSTALLATION SPECIFICATIONS AND PREPARATION FOR MODEL IH4227

1. A straight, short duct run will allow the hood to perform more efficiently. Limit the number of elbows and transitions to as few as possible. Long duct runs, elbows and transitions will reduce the performance of the hood.

**NOTE:** All hoods must exhaust to the outdoors.

**NOTE:** There is a possibility of noise issues, if a short duct run is coupled with a remote blower.

2. Always use metal ducting. Do not use flex ducting.
3. Wolf recommends installing a back-draft damper in all installations (included with hood). In cold weather installations a back-draft damper is necessary to minimize the back-flow of cold air into the room.
4. Wolf recommends the hood be installed 24" (610 mm) to 30" (762 mm) above the cooking surface.

**NOTE:** Local building codes may require the use of make-up air. Consult a local HVAC professional for specific requirements.

### ELECTRICAL REQUIREMENTS

Wolf cooktop wall hoods require a separate, grounded, 110/120 VAC, 60 Hz power supply. The service should have its own 15 amp circuit breaker.

**NOTE:** You must follow all National Electrical Code regulations. In addition, be aware of local codes and ordinances when installing your service.

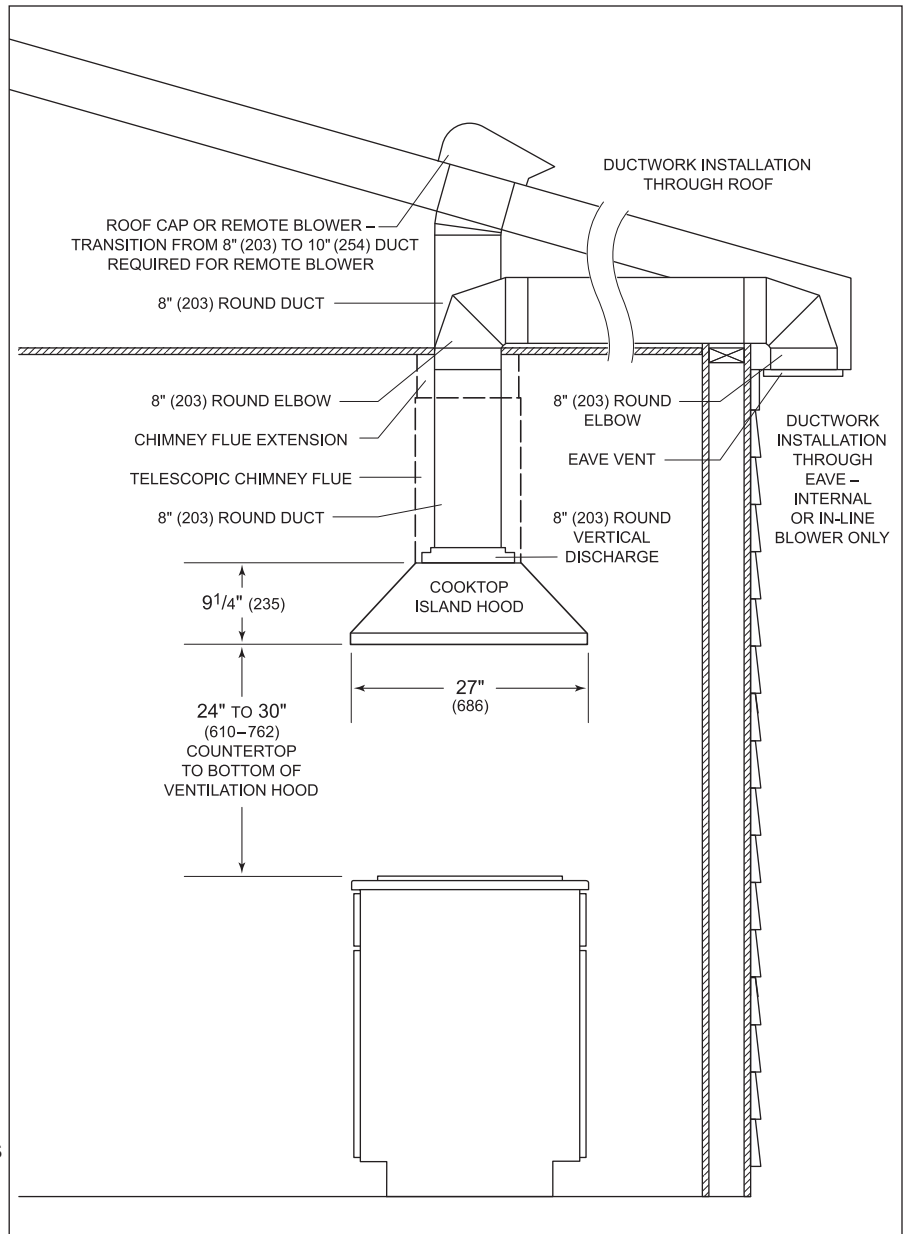

Figure 2-15 Island Hood Installation Considerations

**COOKTOP ISLAND HOOD INSTALLATION**

**⚠ WARNING**

**DUE TO THE WEIGHT OF SOME HOODS, SEVERAL PEOPLE MAY BE REQUIRED FOR A SAFE AND PROPER INSTALLATION.**

**FRAMING MUST BE STRUCTURALLY TIED TOGETHER AND TIED TO CEILING JOISTS TO PROVIDE ENOUGH STRENGTH TO SUPPORT WEIGHT OF THE HOOD AND INTERNAL BLOWER, IF APPLICABLE.**

**INSTALL SUPPORT SYSTEM**

1. At the island hood installation location, install two-by-four or 3/4"(19) plywood cross framing between ceiling joists. Refer to the island hood mounting pattern dimensions. (See Figure 2-16)
2. Finish the ceiling surface. Be sure to mark the location of the ceiling joists and cross framing.
3. Determine the desired orientation of the island hood. Note that the front designates the control side of the hood.
4. Secure the upper half of the support frame to the joists and cross framing with four screws provided with your hood. Make sure that the screws are driven into the center of the joists and framing for maximum strength. (See Figure 2-17)
5. Adjust the overall height of the support frame. Loosen and retighten the screws in the height adjustment slots as necessary. (See Figure 2-17)

**NOTE:** The hood height is 11 1/4"(286) from the support frame attachment point. The bottom of the hood must be 24" (610) minimum and 30" (762) maximum from the countertop.

6. Secure the upper telescopic chimney flue section to the upper support frame. (See Figure 2-18)

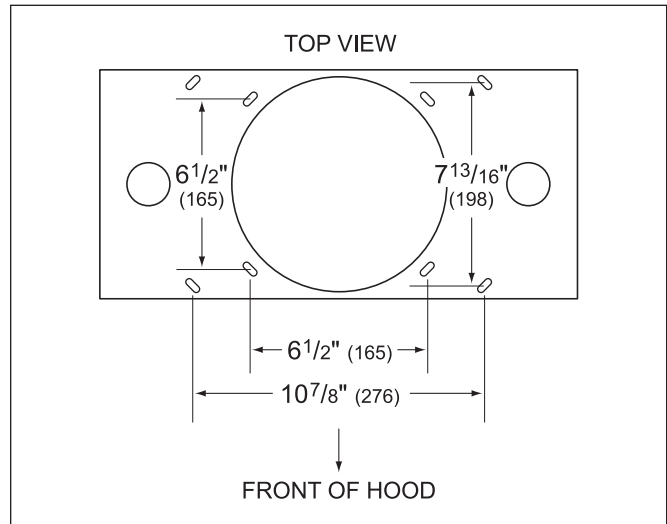

Figure 2-16 Telescopic Flue Mounting

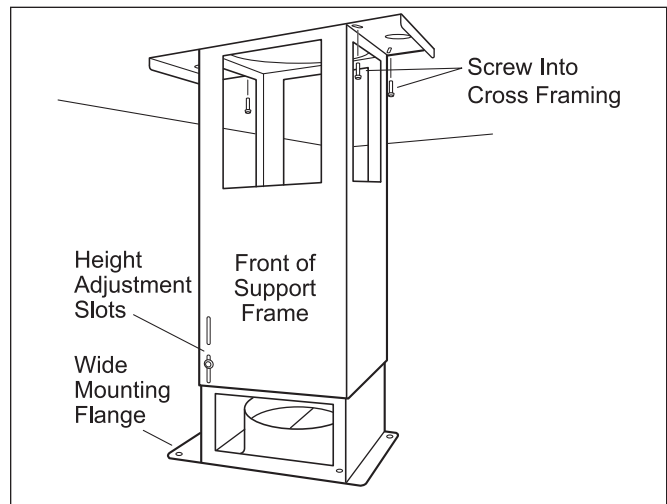

Figure 2-17 Support Frame

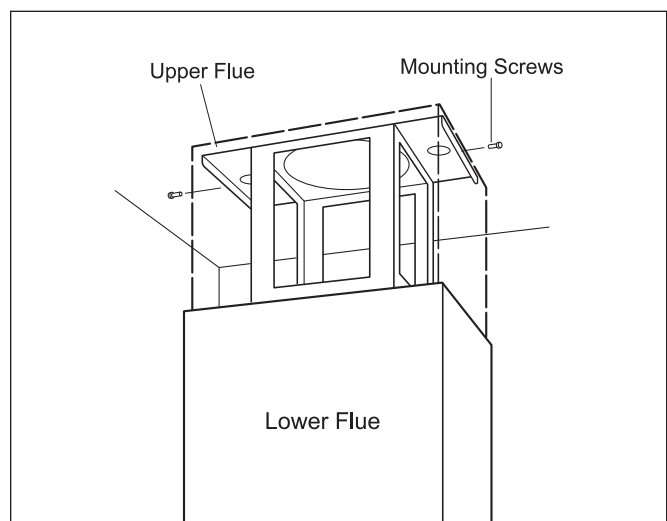

Figure 2-18 Upper Chimney Flue Mounting

## MOUNT HOOD TO SUPPORT FRAME

1. Temporarily secure the lower telescopic chimney flue section over the upper flue section.
2. Mount the hood to the support frame by aligning the four weld screws on the hood to the four holes on the support frame. Use four nuts to secure the hood to the support frame. (See Figure 2-19).

### **⚠ WARNING**

**TO REDUCE THE RISK OF ELECTRICAL SHOCK, THIS VENTILATION HOOD MUST BE PROPERLY GROUNDED.**

**UNIT SHOULD BE CONNECTED ELECTRICALLY BY A QUALIFIED ELECTRICIAN IN ACCORDANCE WITH ALL APPLICABLE NATIONAL AND LOCAL ELECTRICAL CODES.**

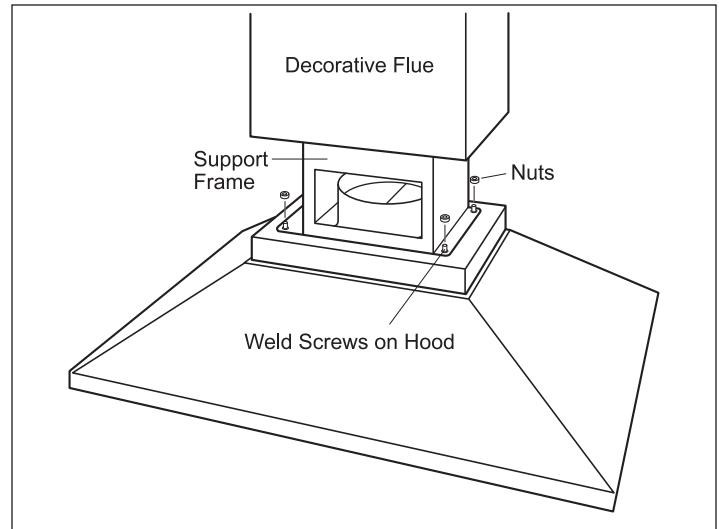

Figure 2-19 Mounting Hood to Support System

## ELECTRICAL CONNECTIONS

1. Remove the cover from the rear electrical box knockout that faces the hood's discharge collar.
2. Insert 6" (152) of 120 VAC power cable through the knockout opening. Secure the cable to the electrical box with an appropriate connector.
3. Make electrical connections. Connect black to black, white to white and green/yellow to green or bare wire. (See Figure 2-20)
4. Reinstall the electrical box cover and screws. Make sure that all wires are secure and that no wires are pinched between the cover and box.
5. Use an 8" (203) round metal duct to connect the duct collar on the hood to the ductwork above. Use duct tape to make all joints secure and air tight.
6. Slide the lower telescopic chimney flue section downward until it fits properly around the hood shell.

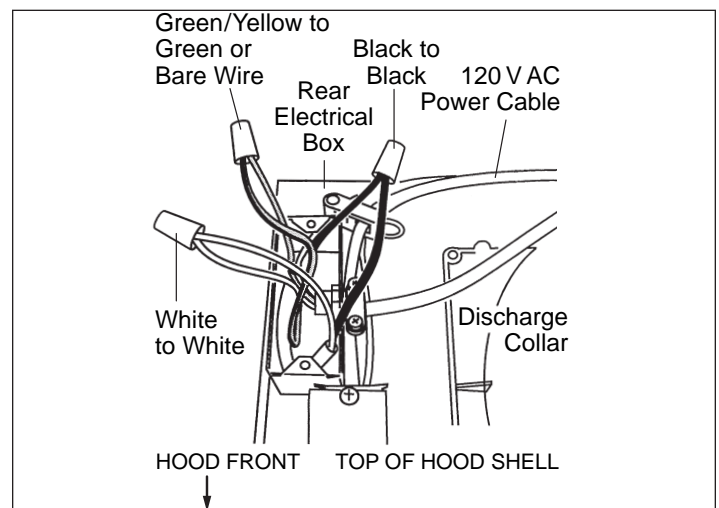

Figure 2-20 Electrical Connections

**INTERNAL BLOWER INSTALLATION**

**⚠ WARNING**

**TO REDUCE THE RISK OF ELECTRICAL SHOCK, POWER SHOULD BE TURNED OFF TO UNIT BEFORE ATTEMPTING THE FOLLOWING PROCEDURE.**

**INTERNAL BLOWER INSTALLATION**

**NOTE:** Before turning the power on, make sure blower control is in the “OFF” position. Use wire connectors or wire nuts approved by UL or C/UL. Refer to installation instructions provided with each blower to verify wall or roof cut-outs.

**NOTE:** Blower options vary with the cooking surface. Use only a Wolf blower with the cooktop ventilation hood.

**NOTE:** For mounting and installation of the internal blower, refer to the specific installation instructions provided with each blower.

1. Remove the hood filters.
2. Lift the blower into position inside the hood, the threaded studs on the blower will slide through the slots provided in the upper panel.
3. Use four hex nuts provided with the blower to fasten the unit to four threaded studs. (See Figure 2-21)
4. Plug the blowers’ single power cord (double for some blowers) into the receptacle(s) inside the hood. Use the clip on the hood to keep excess power cord away from moving parts.
5. Reinstall the hood filters.

**NOTE:** Before turning the power on, make sure the blower control is in the OFF position.

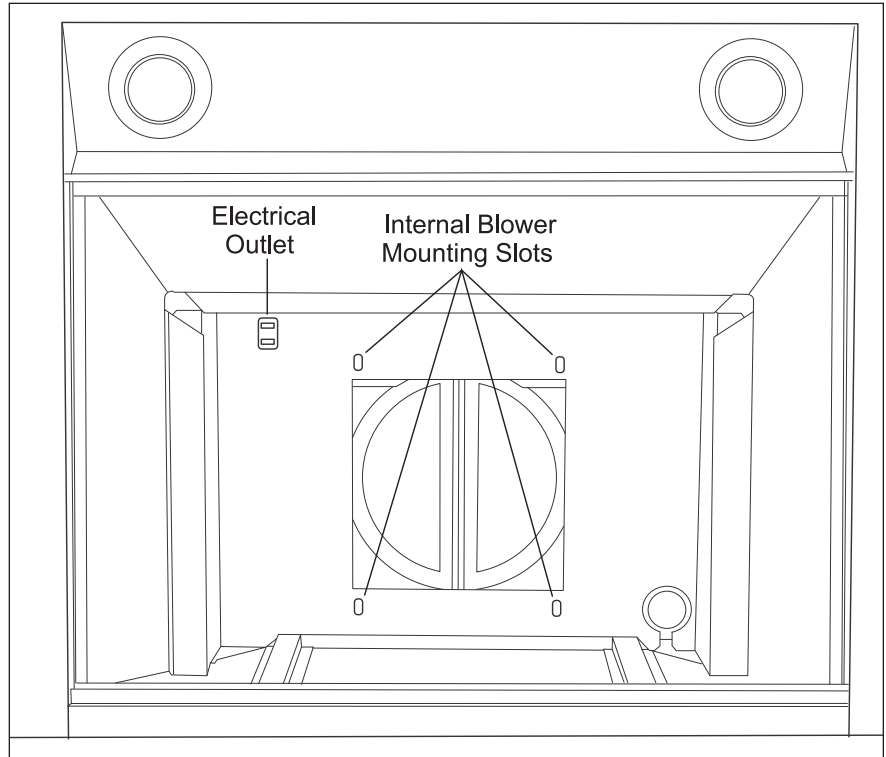

Figure 2-21 Internal Blower Install

### CTE WALL HOOD INSTALLATION CONSIDERATIONS

#### **⚠ WARNING**

**TO REDUCE THE RISK OF FIRE, USE ONLY METAL DUCTWORK.**

#### **⚠ CAUTION**

**TO REDUCE THE RISK OF FIRE AND ELECTRIC SHOCK, THIS VENTILATION HOOD SHOULD ONLY BE INSTALLED WITH BLOWERS MANUFACTURED BY WOLF APPLIANCE INC. AND SPECIFIED FOR USE WITH THESE VENTILATION MODELS.**

#### INSTALLATION OPTIONS:

##### 1. Ducted Installation.

In a ducted installation, the hood aspirates the kitchen air saturated with fumes and odors, passes it through the grease filter(s) and expels it to the outside through ductwork.

For this installation, a hood with an internal,

in-line or remote blower can be used. In-line blowers are located in ductwork between the hood and the outside.

For wall hoods, the remote blower can be mounted on the roof or an exterior wall. Wolf in-line and remote blower assemblies are available through your Wolf dealer.

##### 2. Recirculating Installation.

In a recirculating installation, the hood aspirates the kitchen air saturated with fumes and odors, purifies it through the grease filter(s) and charcoal filter and returns clean air into the room. For constant efficiency, the charcoal filter must be replaced periodically. For this installation, a recirculation kit available through your Wolf dealer will be required.

**NOTE:** For Installation instructions for Recirculating Option please see Installation Manual that was provided with the product.

#### LOW-PROFILE HOOD INSTALLATION SPECIFICATIONS AND PREPARATIONS

Decide where the ductwork will run between the hood and the outside. A straight, short duct run will allow the hood to perform more efficiently. Limit the number of elbows and transitions to as few as possible. Long duct runs, elbows and transitions will reduce the performance of the hood. Wolf recommends the maximum linear duct run be no greater than 50' (15 m).

**NOTE:** There is a possibility of noise issues, if a short duct run is coupled with a remote blower.

Wolf recommends installing a backdraft damper in all installations. A backdraft damper is included with the hood. It is built into the transition from the hood to the duct run. Unless you are using a remote blower, a roof or wall cap should be installed. Connect ductwork to the cap and work back towards the hood. Use duct tape to seal the ductwork joints.

**NOTE:** Local building codes may require the use of make-up air. Consult a local HVAC professional for specific requirements.

**NOTE:** Consult a qualified HVAC Engineer for specific ducting applications.

**LOW-PROFILE WALL HOODS INSTALLATION SPECIFICATIONS AND PREPARATIONS**

**NOTE:** This installation must be completed by a qualified installer or Wolf authorized service center technician.

**NOTE:** Low Profile Hoods are designed for use with a 6" diameter duct.

**CTE WALL HOOD DUCTED INSTALLATION**

1. Locate the electrical supply through the wall within the shaded area shown in Figure 23.
2. Install ductwork as outlined on page 2-13 & Figure 2-22.
3. If an optional backsplash is to be used, attach it to the finished wall. Secure the hood mounting brackets to the wall studs prior to installing the backsplash.

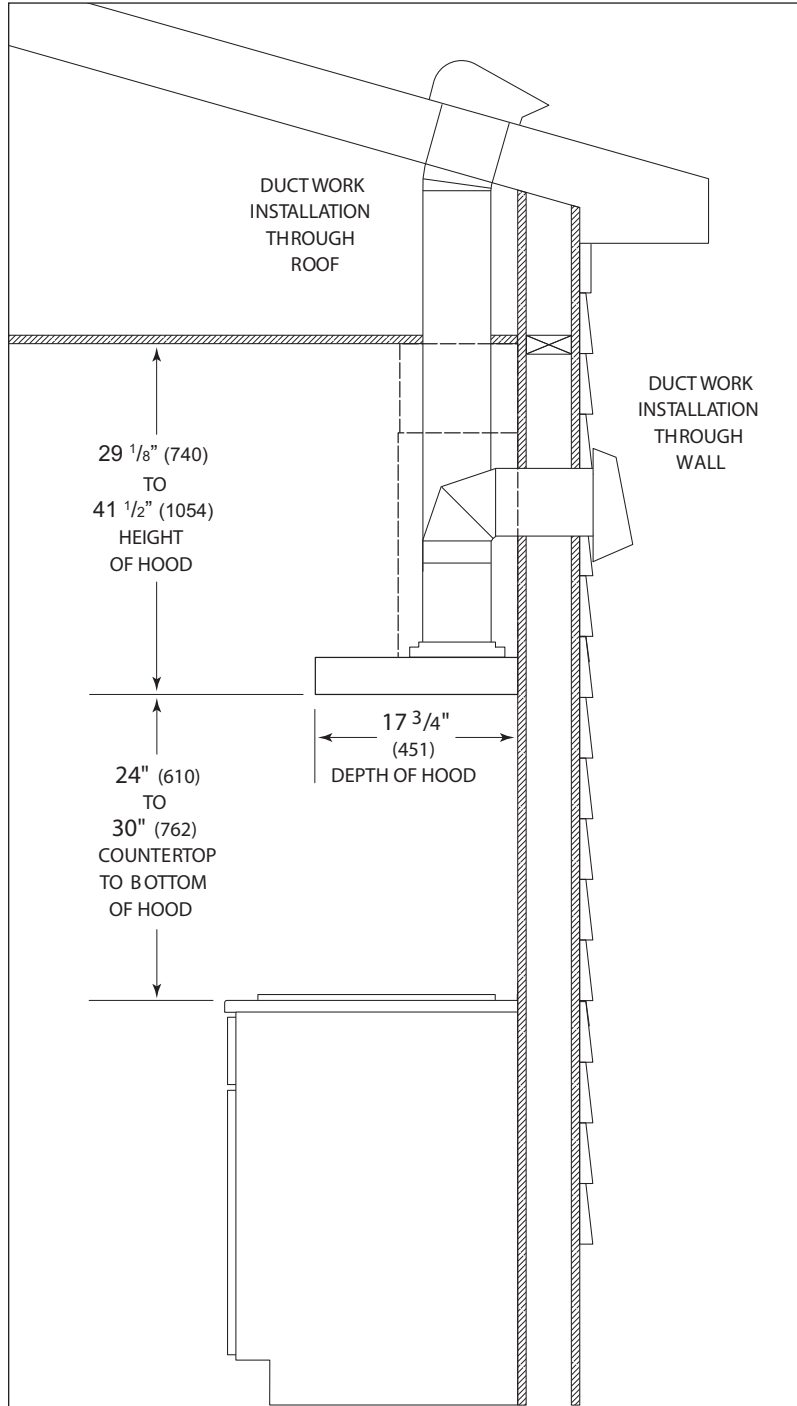

Figure 2-22 CTE Wall Hood Installation Considerations

## ELECTRICAL REQUIREMENTS

Wolf low-profile hoods require a separate, grounded, 110/120 VAC, 60 Hz power supply. The service should have its own 15 amp circuit breaker.

**NOTE:** You must follow all National Electrical Code regulations. In addition, be aware of local codes and ordinances when installing your service.

## FIXING TO THE WALL

1. Draw a line on the wall in vertical line with your hood. Mark the first two holes to be drilled in the wall, respecting the distances indicated in Figure 23. Drill the two holes and fit the screw anchors provided.
2. For best capture of cooking impurities, the bottom of the hood should be a minimum of 24" (610) and a maximum of 30" (762) above THE COUNTERTOP.
3. Fix the metal bracket (A) to the wall using the two holes just drilled as shown in Figure 24. The screws for fixing the bracket are provided. Use the two cut-out triangles on the bracket to position it exactly along the vertical axis of the hood.
4. Hang the hood on the bracket as shown in Figure 25. Adjust the horizontal position moving the hood to the right or left so that it is aligned with the wall units. When adjustment has been completed, without removing the hood, mark the other four holes to be drilled (C) in the wall. Remove the hood and drill the holes marked (5/16" diameter). Then use the four screw anchors and the four screws provided for final fixing.
5. Mount the plate of the electrical system fixing it with three screws.

## FIXING THE TELESCOPIC FLUE

1. Adjust the width of the support bracket (D) of the telescopic flue by means of the screws (E) as shown in Figure 26. Then, by means of the screw anchors and screws (F) provided, fix the bracket to the ceiling in such a way that it is positioned along the axis with your hood.
2. Connect the air outlet pipe to the air vent of the hood. Use a flexible pipe and lock it to the air vent of the hood with a metal hose clamp as shown in Figure 27 (pipe and clamp are not provided).
3. For exhaust hoods, turn the upper flue over so that the air exhaust grid is in the lower section.

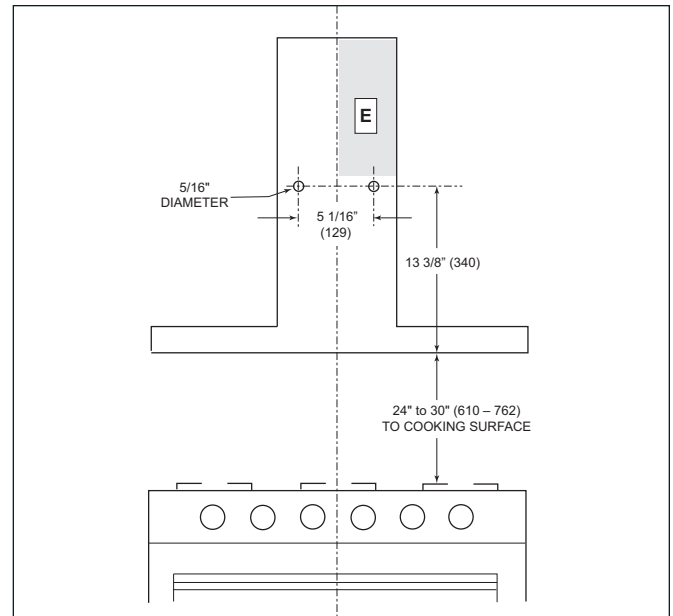

Figure 2-23 CTE Wall Hood Mounting Plate Placement

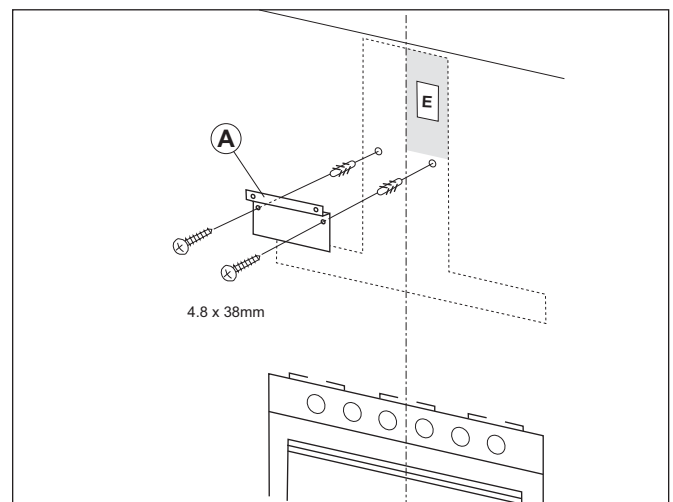

Figure 2-24 CTE Wall Hood Mounting Plate Mounting

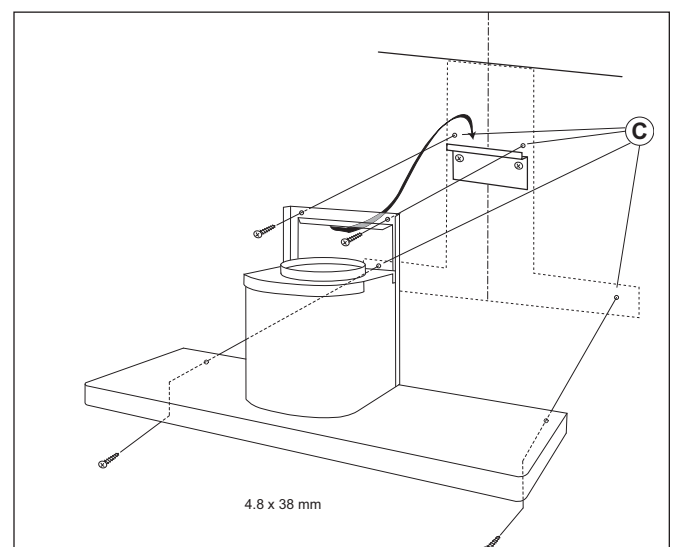

Figure 2-25 CTE Wall Hood Mounting

**WIRING**

**NOTE:** The ventilation hood must be properly grounded. It should be installed by a qualified electrician in accordance with all applicable national and local electrical codes.

1. Run supply conductors to the hood wiring box marked "120 VAC input".
2. Remove the cover from the wiring box and remove one knockout as shown in Figure 28.
3. Secure the conduit to the wiring box through a conduit connector.
4. Make electrical connections at the hood. Connect white-to-white, black-to-black and green-to-ground.
5. Replace the wiring box cover and screws. Make sure wires are not pinched between the cover and box.

**FINAL STEP**

Insert the flue extensions setting them on the hood. Extend the upper flue to the ceiling and secure with the two screws (H) as shown in Figure 29.

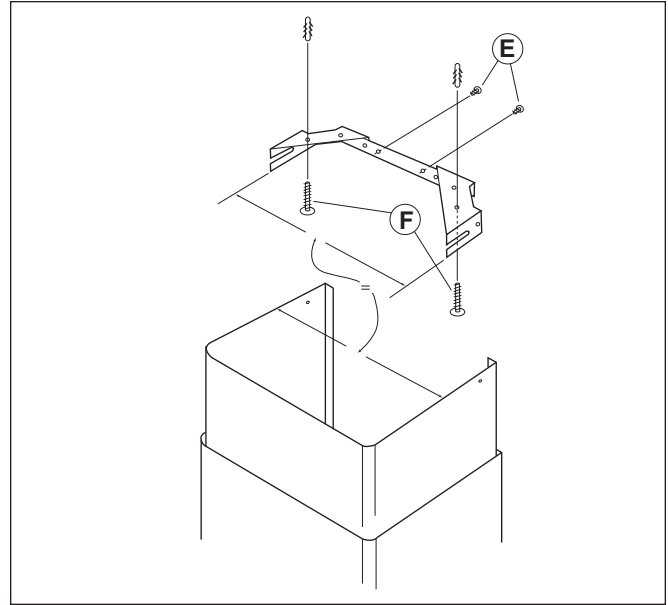

Figure 2-26 CTE Wall Hood Flue Support Bracket

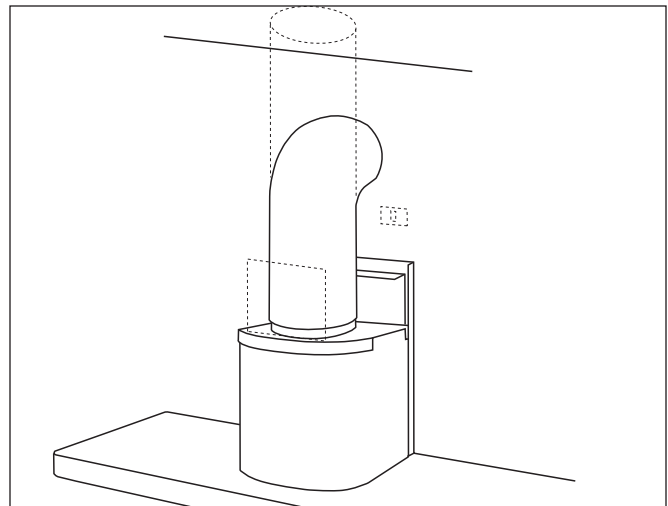

Figure 2-27 CTE Wall Hood Air Outlet Pipe

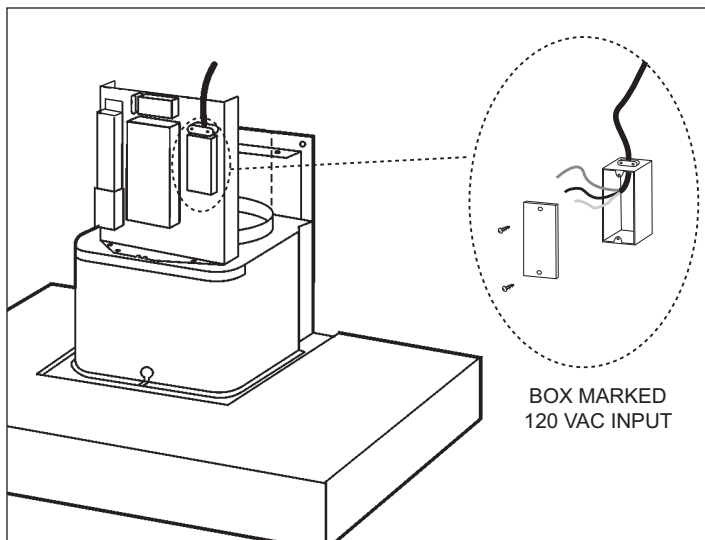

Figure 2-28 CTE Wall Hood Electrical Connection

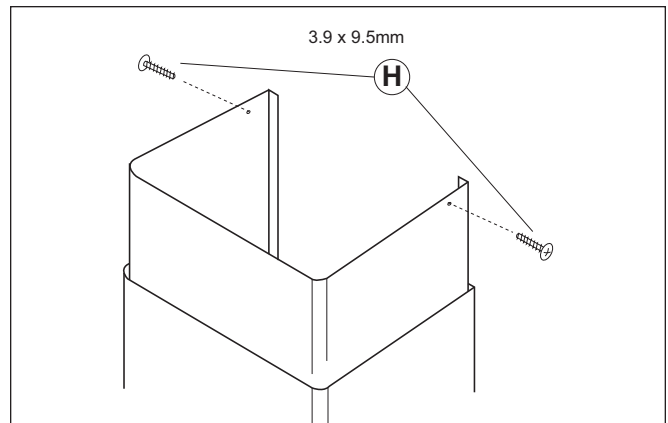

Figure 2-29 CTE Wall Hood Flue Securing



**⚠ WARNING**

TO REDUCE THE RISK OF FIRE, USE ONLY METAL DUCTWORK.

**⚠ CAUTION**

TO REDUCE THE RISK OF FIRE AND ELECTRIC SHOCK, THIS VENTILATION HOOD SHOULD ONLY BE INSTALLED WITH BLOWERS MANUFACTURED BY WOLF APPLIANCE INC. AND SPECIFIED FOR USE WITH THESE VENTILATION MODELS.

**Low-Profile Island Hood Installation Specifications and Preparation**

**NOTE:** This installation must be completed by a qualified installer or Wolf authorized service center technician.

1. Locate the electrical supply through the ceiling inside the area of the flue.
2. Install ductwork as outlined on page 2-13 & Figure 2-30.

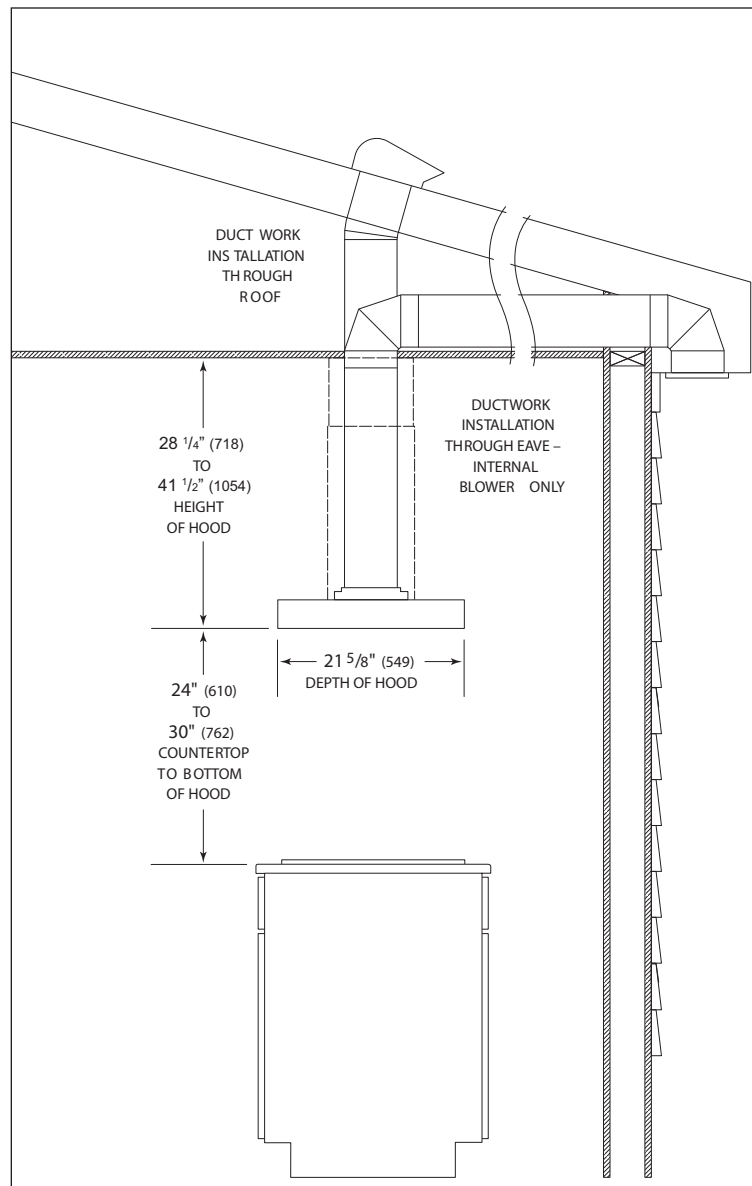

Figure 2-30 CTEI Hood Installation Considerations

**CTE ISLAND HOOD INSTALLATION**

**ELECTRICAL REQUIREMENTS**

Wolf low-profile hoods require a separate, grounded, 110/120 VAC, 60 Hz power supply. The service should have its own 15 amp circuit breaker.

**NOTE:** You must follow all National Electrical Code regulations. In addition, be aware of local codes and ordinances when installing your service.

**FIXING TO THE CEILING**

1. Mount the metal panel with four screws as shown in Figure 31.
2. Using the drilling template, drill the holes for fixing to the ceiling on the vertical side of your hood. The center line of the mounting plate (Figure 32) is in line with the center of the control panel. Carefully observe this indication to ensure proper alignment of the hood with the cooking product.
3. Fix the bracket to the ceiling using the screws and screw anchors provided as shown in Figure 33.

**NOTE:** The position of the bracket determines the final position of the hood. The side with the slot (B) corresponds to the side opposite the controls.

4. Assemble the plate of the electrical system fixing it with two screws and two metal washers as shown in Figure 34.
5. Fix the telescopic flue to the bracket by means of four screws (provided), running the air evacuation pipe through the telescopic flue and the electric power cable through the special hole in the bracket as shown in Figure 35.
6. Adjust the height of the telescopic flue by means of the four retaining screws (C) shown in Figure 35. Take into account that the height of the hood is 3 1/8" (79) and the bottom of the hood should be a minimum of 24" (610) and a maximum of 30" (762) above the counter-top.
7. Take the upper flue (with the round slots) and slide it on the telescopic flue with the slots facing upwards. Attach the flue to the bracket with two screws as shown in Figure 36.
8. Take the lower flue and slide it over the upper flue, to the top and secure it in that position using adhesive tape.
9. Raise the hood to the telescopic flue and connect the air outlet duct to the hood. Attach the hood to the telescopic flue by means of four screws (provided) as shown in Figure 37.

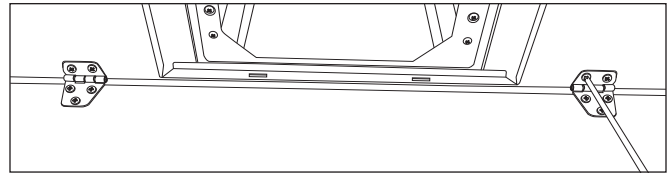

Figure 2-31 CTE Island Hood Metal Panel Mounting

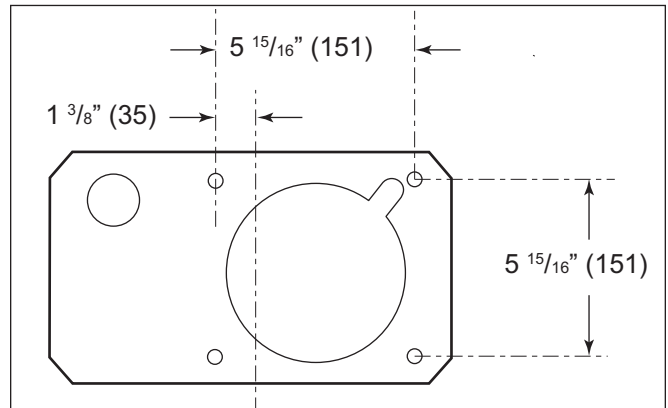

Figure 2-32 CTE Island Hood Plate Dimensions

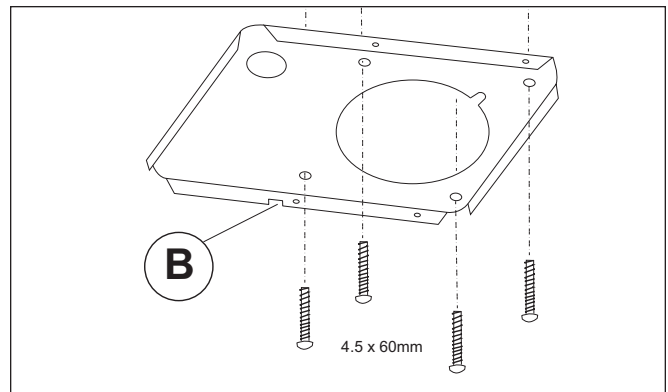

Figure 2-33 CTE Island Hood Ceiling Plate Mounting

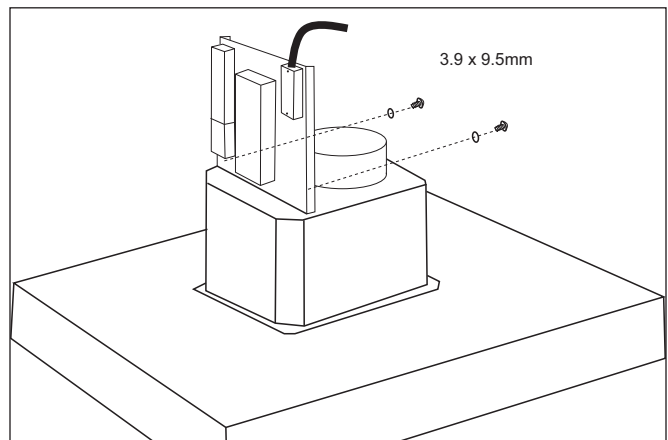

Figure 2-34 CTE Island Hood Control Plate

## WIRING

**NOTE:** The ventilation hood must be properly grounded. It should be installed by a qualified electrician in accordance with all applicable national and local electrical codes.

1. Run supply conductors to the hood wiring box marked "120 VAC input".
2. Remove the cover from the wiring box and remove one knockout as shown in Figure 38.
3. Secure the conduit to the wiring box through a conduit connector.
4. Make electrical connections at the hood. Connect white-to-white, black-to-black and green-to-ground.
5. Replace the wiring box cover and screws. Make sure wires are not pinched between the cover and box.

## FINAL STEP

Remove the adhesive tape and slide the lower flue downward, placing it gently onto the hood base. Installation is now complete and the grease filters can be installed.

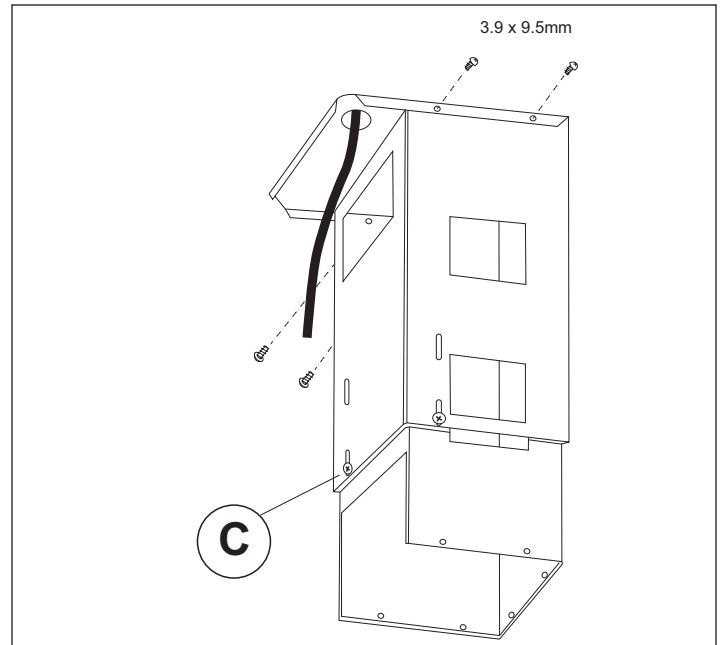

Figure 2-35 CTE Island Hood Telescopic Flue Mounting

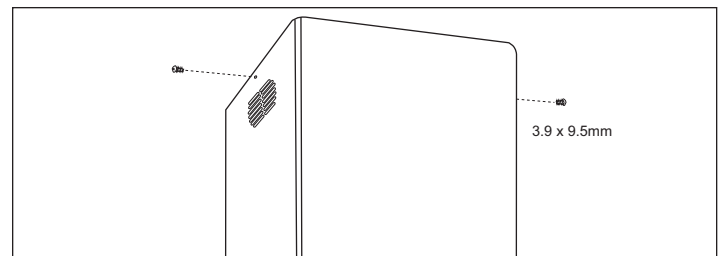

Figure 2-36 CTE Island Hood Upper Flue Mounting

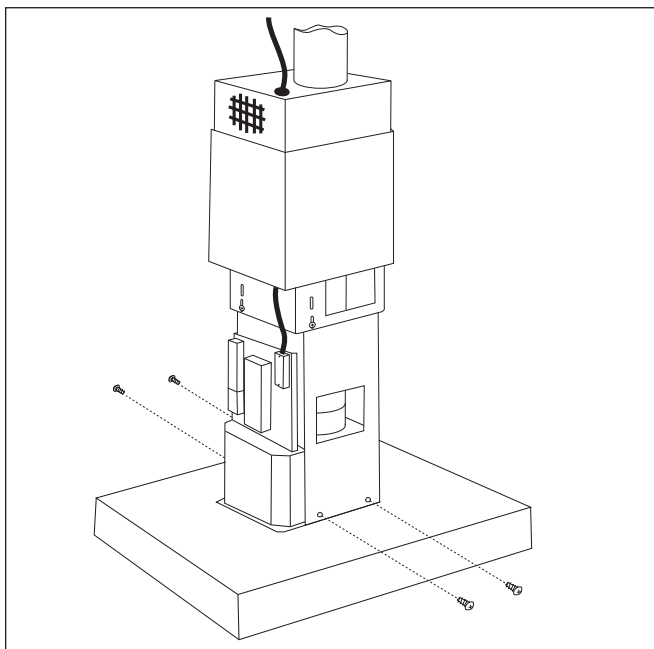

Figure 2-37 CTE Island Hood to Telescopic Flue

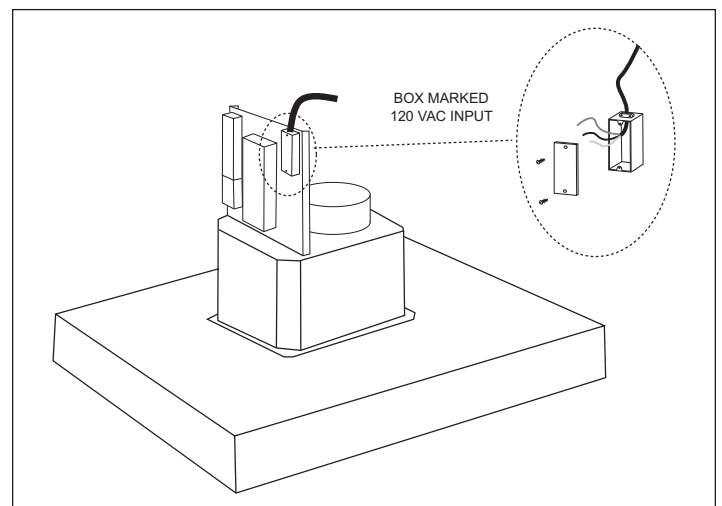

Figure 2-38 CTE Island Hood Electric Hookup

**REMOTE BLOWER INSTALLATION**

**⚠ WARNING**

**TO REDUCE THE RISK OF ELECTRICAL SHOCK, POWER SHOULD BE TURNED OFF TO UNIT BEFORE ATTEMPTING THE FOLLOWING PROCEDURE.**

**REMOTE BLOWER INSTALLATION**

**NOTE:** Before turning the power on, make sure the blower is in the “OFF” position. Use wire connectors or wire nuts approved by UL or C/UL..

**NOTE:** Detailed instructions of Remote Blower installation are provided with the blower. Refer to installation instructions provided with each blower to verify wall or roof cut-outs. The following information is simply intended to summarize the process.

1. Locate the blower so the length of the duct run and number of elbows and transitions are kept to a minimum.
2. Where possible, blower should be located between wall studs or roof rafters.
3. Avoid pipes, wires or other ductwork that may be running through the wall.
4. Be sure that there is enough space for any transitions that may be needed between the blower and the connecting ductwork.
5. For best performance, locate transitions nearest the blower.

**CONNECT REMOTE BLOWER**

**NOTE:** Always refer to all blower installation instructions provided with the blower for additional mounting and wiring instructions.

1. Remove the cover from the front of the electrical box. Remove the electrical box knockout that faces the hood's discharge collar.
2. Disconnect the red, black or white wires using a flat-blade screwdriver. (See Figure 2-39)
3. Insert 6” (152) of the remote blower wiring through the knockout opening. Secure the cable to the electrical box with an appropriate connector. Use wire connectors or wire nuts approved by UL or C/UL.
4. Attach the remote blower wiring where the wires were removed in step 2. (See Figure 2-40)
5. Re-install wiring box cover and screws. Make sure all wires are secure and that no wires are pinched between cover and box.

**NOTE:** Before turning the power on to the ventilation hood, make sure the blower is in the OFF position.

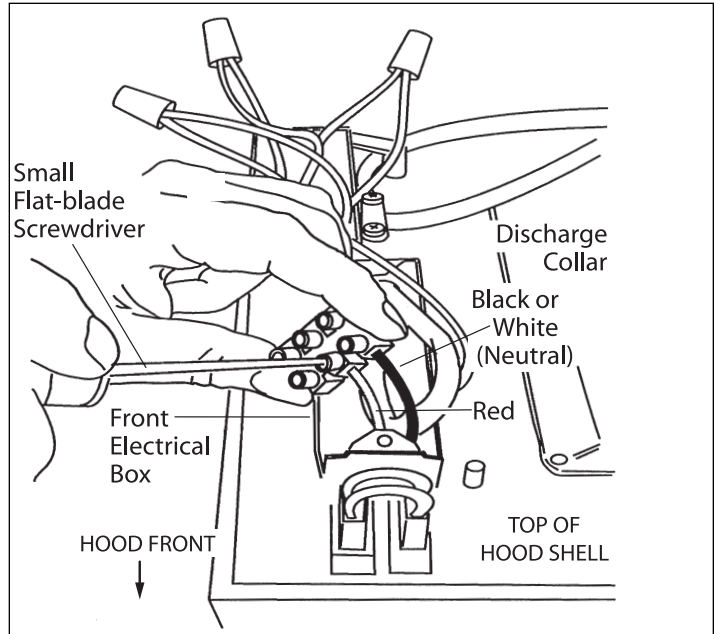

Figure 2-39 Remote Blower Electrical Connections Prepare

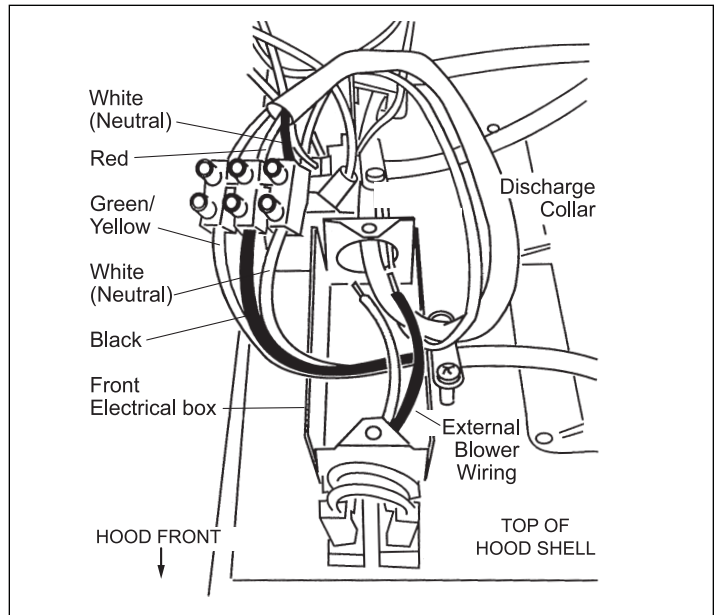

Figure 2-40 Remote Blower Electrical Connections

## DOWNDRAFT DIMENSIONS

### ⚠ CAUTION

TO REDUCE THE RISK OF FIRE AND ELECTRIC SHOCK, THIS VENTILATION HOOD SHOULD ONLY BE INSTALLED WITH BLOWERS MANUFACTURED BY WOLF APPLIANCE INC. AND SPECIFIED FOR USE WITH THESE VENTILATION MODELS.

**NOTE:** Wolf downdraft ventilation systems are recommended for use with Wolf framed electric, gas, induction and multi-function cooktops. They cannot be used with unframed electric cooktops and are not recommended for use with the electric grill, steamer and fryer modules. A Pro ventilation hood must be used with Wolf dual fuel ranges, gas ranges and rangetops.

Wolf downdraft ventilation systems are available in 30" (762), 36" (914) and 45-1/2"(1156) widths. The downdraft should be at least as wide as the cooktop. Models DD30I, DD36I and DD45I include a 500CFM internal blower. Models DD30R, DD36R and DD45R are shipped without a blower assembly.

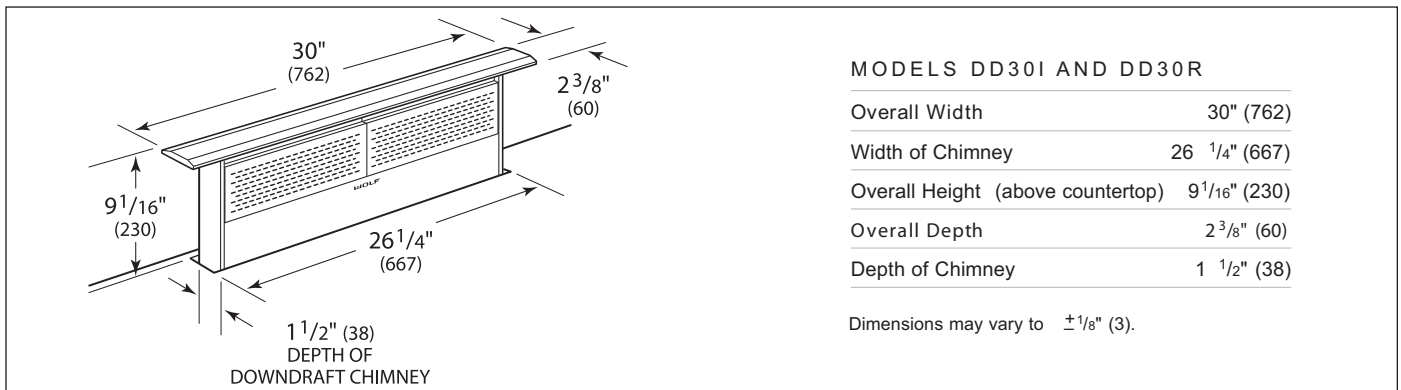

Figure 2-41 Models DD30I & DD30R

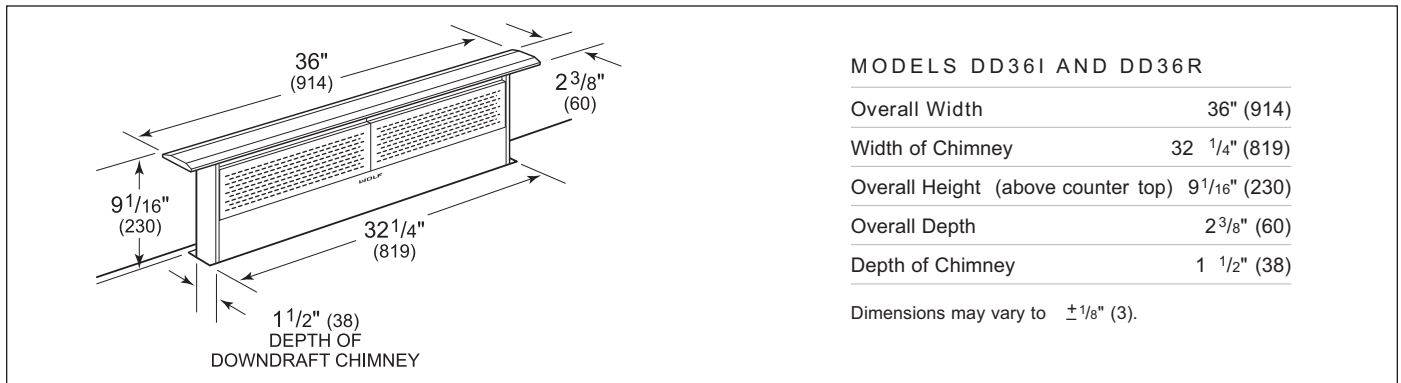

Figure 2-42 Models DD36I & DD36R

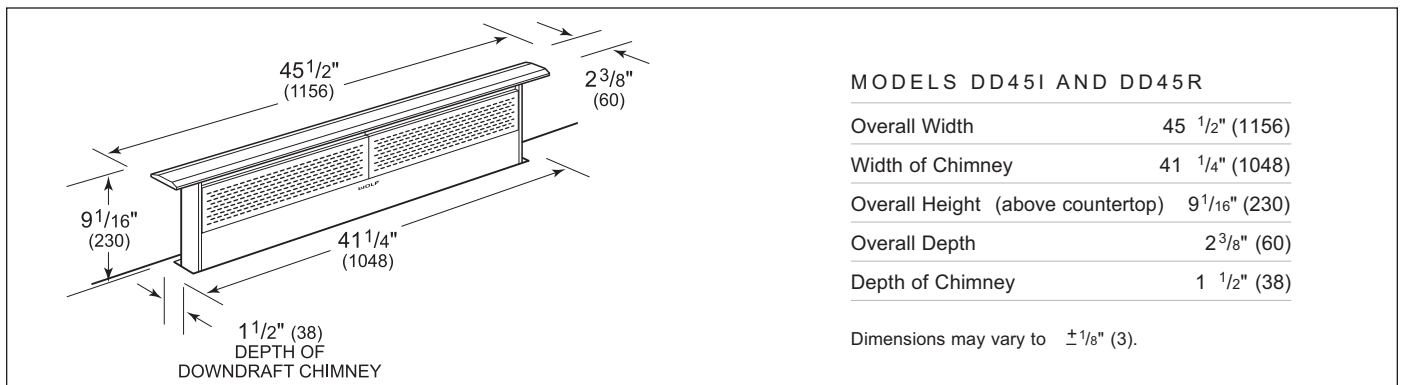

Figure 2-43 Models DD45I & DD45R

**DOWNDRAFT INSTALLATION SPECIFICATIONS**

**INSTALLATION SPECIFICATIONS**

Wolf downdraft Model DD30 will fit most 30" (762) wide cabinets, Model DD36 will fit most 36" (914) wide cabinets and Model DD45 will fit most 45-1/2"(1156) wide cabinets. It is recommended that oversized cabinets be used for easier installation. Cabinet backs may need to be removed. Wolf downdraft ventilation systems can be mounted in an island, peninsula or standard wall location.

**NOTE:** To install a downdraft system and a Wolf cooktop, you must allow for a minimum 25-1/8"(638) flat counter space from front to back. A countertop with a raised lip or backsplash may not allow enough space for proper installation. 2-3/8"(60) of flat countertop is required behind the cooktop and 1-3/4"(44) is necessary between the back edge of the cooktop and inside of cabinet back.

If downdraft Model DD30 is installed in combination with two cooktops or integrated modules, an integrated module support (available as a sales accessory) for downdraft ventilation is required. Model DD45 does not require this accessory. If optional filler strips are used with the cooktops or modules, be aware that they are different for the Model DD30 and DD45. Be sure to use the correct filler strip.

For installation of a downdraft system with a cooktop, refer to the cooktop installation instructions for the dimensions of the cooktop, countertop cut-out and cabinet requirements. The depth of the cooktop may vary and will affect the location of the downdraft in the countertop. Figure 2-45 provides countertop cut-out dimensions for downdraft Models DD30, DD36 and DD45 installed with a Wolf 30"(762) or 36" (914) cooktop or combination of cooktop and/or modules.

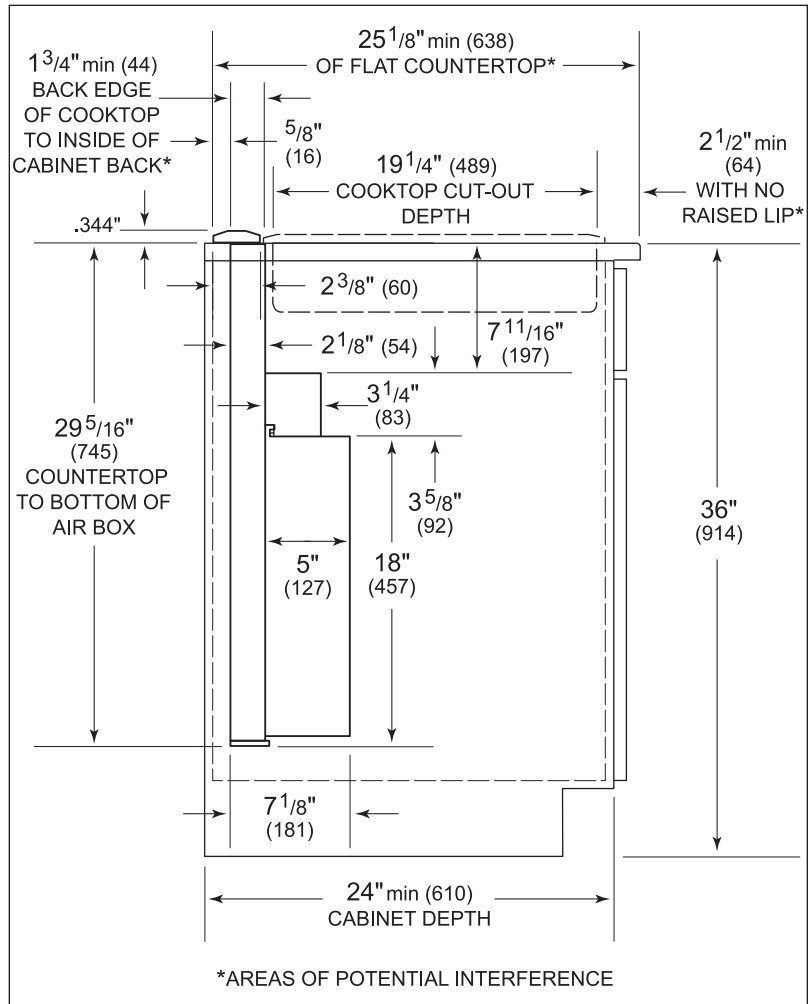

Figure 2-44 Side View Installation Dimensions

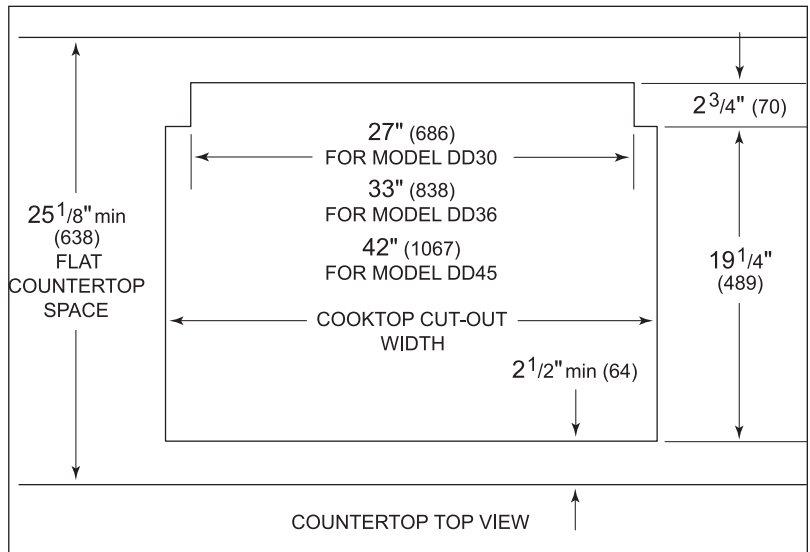

Figure 2-45 Top View Installation Dimensions

### DOWNDRAFT INSTALLATION REQUIREMENTS

#### **⚠ WARNING**

**DOWNDRAFTS MUST BE PROPERLY GROUNDED. UNIT SHOULD BE CONNECTED ELECTRICALLY BY A QUALIFIED ELECTRICIAN IN ACCORDANCE WITH ALL APPLICABLE NATIONAL AND LOCAL ELECTRICAL CODES.**

**DO NOT USE AN EXTENSION CORD OR TWO-PRONG ADAPTER. ELECTRICAL GROUND IS REQUIRED ON THIS APPLIANCE. DO NOT REMOVE THE POWER SUPPLY CORD GROUND PRONG.**

**NOTE:** A ground fault circuit interrupter (GFCI) is not recommended and may cause interruption of operation.

#### **ELECTRICAL REQUIREMENTS**

Wolf downdraft ventilation systems require a separate, grounded 120 VAC, 60 Hz power supply (for ICB power requirements see Section 6). The service should have its own 15 amp circuit breaker, and a grounded 3-prong receptacle should be located within the reach of the 2-1/2' (.8 m) power cord. The specific location of the outlet is not critical, as long as it is within reach of the power cord that is located mid-way, top and bottom, on the right side of the downdraft.

**NOTE:** If Model DD30 is to be installed in a 30" (762) wide cabinet, Model DD36 in a 36" (914) wide cabinet or Model DD45 in a 45-1/2" (1156) wide cabinet, the electrical outlet cannot be located on the back wall of the cabinet. The outlet can be placed in an adjacent cabinet within reach of the power cord. An access hole for the power cord must be drilled in the cabinet wall.

#### **CONTROL MODULE LOCATION**

#### **⚠ WARNING**

**THE DOWNDRAFT MUST BE USED WITH A WOLF APPROVED CONTROL MODULE AND TOP COVER.**

Installation of the remote-mounted control module can be located anywhere within 10' (3 m) of the downdraft assembly and a minimum of 4" (102) from the outer edge of cooktop element or burner. You will be required to drill three holes and connect the control module to the downdraft assembly using the cable provided.

**NOTE:** The length of the control module cable is 10' (3 m). You must plan the installation of the control module to be within 10' (3 m) of the downdraft assembly.

The remote-mounted control module is 2-3/8" (60) x 6-5/8" (168) and can be positioned horizontally or vertically in the countertop. A 5/8" (16) diameter hole for the DIN connector cable will be centered horizontally and vertically in the back side of the control module. Two 1/4" (6) diameter holes for the mounting screws will be located 2" (51) from the center of the DIN connector cable hole, one on each side. Additional installation instructions are provided with the control kit. Mark the center of the control module on the counter top. Measure 2" (51) up (or left) and 2" (51) down (or right) to locate holes for the mounting screws.



**DOWNDRAFT BLOWER AND DUCTING CONSIDERATIONS**

**⚠ WARNING**  
**TO REDUCE THE RISK OF FIRE, USE ONLY METAL DUCTWORK.**

**⚠ CAUTION**  
**TO REDUCE THE RISK OF FIRE AND ELECTRIC SHOCK, THIS VENTILATION HOOD SHOULD ONLY BE INSTALLED WITH BLOWERS MANUFACTURED BY WOLF APPLIANCE INC. AND SPECIFIED FOR USE WITH THESE VENTILATION MODELS.**

**BLOWER CONSIDERATIONS**

The blower will vary in size and is dictated by the cooking surface, the volume of air that needs to be moved and the length of the duct run. A straight, short duct run with a limited number of elbows and transitions will allow the downdraft to perform most efficiently.

A remote-mounted blower will minimize the amount of blower noise, but will not eliminate the noise completely.

**NOTE:** Blower options vary with the cooking surface. For recommendations, refer to the Wolf Design Guide found on the Wolf website, [www.wolfappliance.com](http://www.wolfappliance.com).

**DUCTING CONSIDERATIONS**

**NOTE:** Always consult a qualified HVAC Engineer for specific ducting applications.

**NOTE:** Wolf ventilation downdraft systems must be vented to the outside. Use only rigid metal ductwork.

Wolf downdraft ventilation systems are designed for use with 3-1/4" (83) x 10" (254) ductwork for Models DD30I, DD36I and DD45I, and 3-1/4" (83) x 14" (356) ductwork for Models DD30R, DD36R and DD45R. Each can be transitioned to 8" (203) or 10" (254) round ductwork.

For best performance, 10" (254) round ductwork is recommended. The downdraft will operate most efficiently when the ductwork does not exceed 40' (12 m) in equivalent duct length.

Choose the ducting option that allows the shortest length of ductwork and a minimum number of elbows and transitions. Check the location of floor joists, wall studs, electrical wiring or plumbing for possible interference with the ductwork.

**NOTE:** Use duct tape to seal the connection between the blower outlet and ductwork. Support the weight of the ductwork is necessary to ensure sealed joints.

**ADJUSTABLE DISCHARGE**

Wolf downdraft systems have an adjustable discharge that will allow you to negotiate ducting around floor joists and other obstacles. Three different discharge locations are available with side-to-side adjustment for accurate alignment of ductwork. (See Figure 2-46)

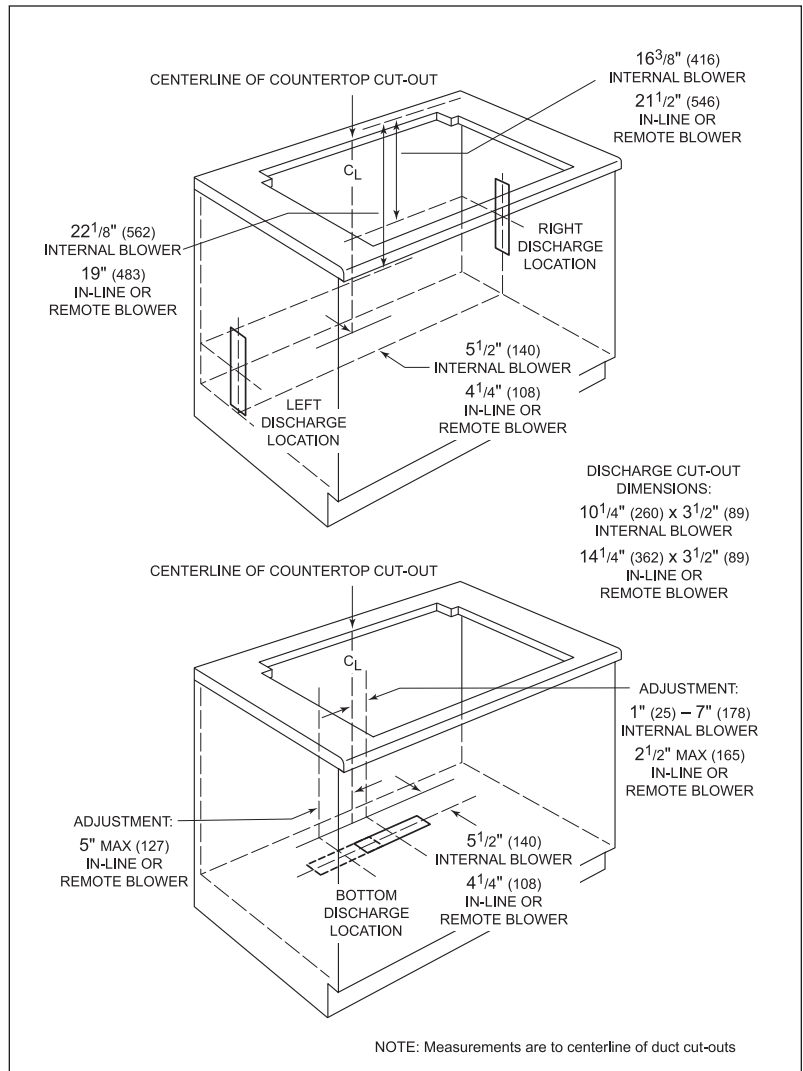

Figure 2-46 Top View Installation Dimensions



## ADJUSTING BLOWER DISCHARGE

Wolf downdraft systems have an adjustable discharge that will allow you to negotiate ducting around floor joists and other obstacles. The blower is shipped with the discharge facing down.

### LEFT TO RIGHT ADJUSTMENT

Adjusting the down discharge left to right will keep the blower discharge in the down position but allows some side-to-side adjustment. (See Figure 2-47)

1. Place the downdraft assembly on its back on a flat work surface.
2. Loosen the 4 nuts and 2 clamp channels.
3. Slide the blower to the desired position.
4. Use the supplied cover plate to close any open space.
5. Tighten nuts to secure the top of blower and use sheet metal screws through the bottom flange to secure the bottom of the blower.

### CHANGING DISCHARGE DIRECTION

Substituting down discharge with left or right discharge will switch the blower discharge from the down position to the left or right of downdraft assembly. (See Figure 2-48)

1. Place the downdraft assembly on its back on a flat work surface.
2. Remove the 4 nuts and 2 clamp channels.
3. Carefully lift the blower and disconnect the motor plug if necessary. Reposition the blower and reconnect the motor plug.
4. Use the supplied cover plate to close any open space.
5. Replace the clamp channels and use the nuts to secure the blower in its new position.
6. Use sheet metal screws through the bottom flange to secure the bottom of the blower.

## DOWNDRAFT INSTALLATION

### MOUNT THE UNIT

1. Set the downdraft into the opening. Extend the leveling brackets to the floor of the cabinet so the downdraft sits straight and connect the ductwork.

**NOTE:** The leveling brackets can be removed and reattached in other positions. The flange of the leveling bracket may have to face inward in tight cabinet installations. Refer to the illustration below.

2. Secure the downdraft to the countertop by holding the downdraft against the back of the countertop cut-out and tightening the two mounting screws (one on each end of unit) on the underside of the countertop. (See Figure 2-49)
3. Screw the leveling brackets to the bottom of the cabinet. Tighten the screws holding the leveling brackets to unit on each side.

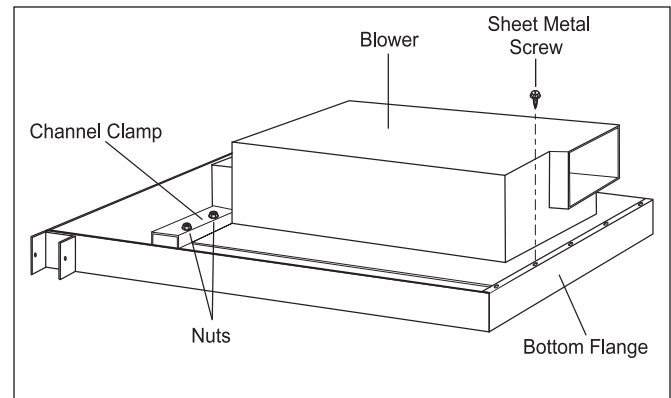

Figure 2-47 Left to Right Adjustment

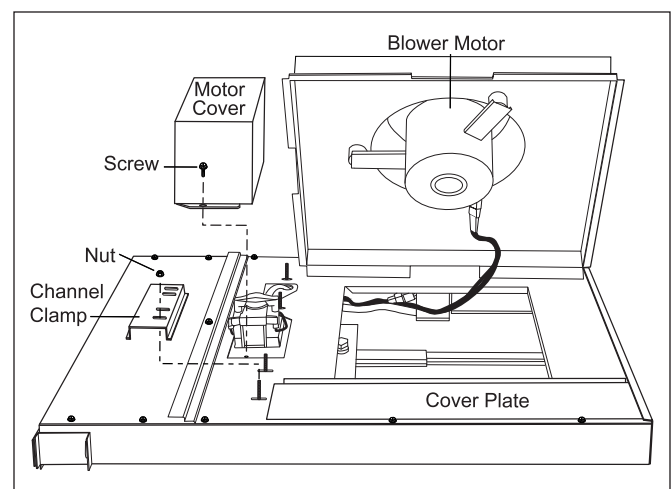

Figure 2-48 Rotating Blower Discharge Direction

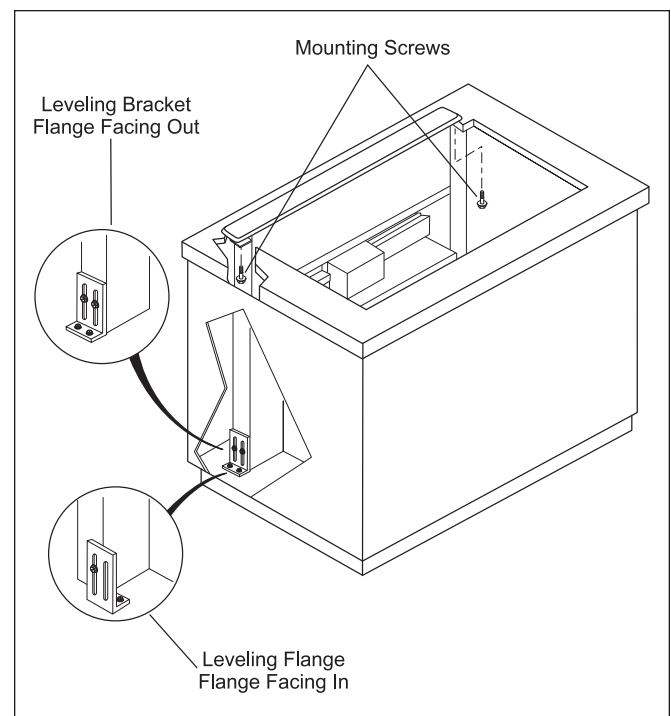

Figure 2-49 Mounting Downdraft Into Cabinet

## CONNECT THE CONTROL MODULE

1. Connect the DIN/RJ45 connector cable to the backside of the remote-mounted control module.
2. Connect the other end of the cable to the electrical connection located on the right side of downdraft assembly. Make sure that all connections are tight.
3. Refer to the illustration on the front of the downdraft for the correct orientation of the DIN connector during installation into the downdraft assembly.

## INTERNAL BLOWER WIRING

Models DD30I, DD36I and DD45I

1. Since these models come with the Blower already installed in the unit, there is no special wiring required.
2. Plug the power cord of the downdraft into the outlet and energize the receptacle.

## REMOTE BLOWER WIRING

Models DD30R, DD36R and DD45R

**NOTE:** The remote blower may not exceed a 6.0 amp rating

**NOTE:** Detailed instructions of Remote Blower installation are provided with the blower. Refer to installation instructions provided with each blower to verify wall or roof cut-outs.

**NOTE:** Before turning the power on, make sure the blower is in the "OFF" position. Use wire connectors or wire nuts approved by UL or C/UL.

1. Locate the blower so the length of the duct run and number of elbows and transitions are kept to a minimum.
2. Where possible, blower should be located between wall studs or roof rafters.
3. Avoid pipes, wires or other ductwork that may be running through the wall.
4. Be sure that there is enough space for any transitions that may be needed between the blower and the connecting ductwork.
5. For best performance, locate transitions nearest the blower.

## CONNECT REMOTE BLOWER

**NOTE:** Always refer to blower installation instructions provided with the blower for additional mounting and wiring instructions.

1. Run 2-wire plus ground power cable from the remote blower to the electrical box on the remote blower adapter plate.
2. Connect the downdraft wiring to the power cable from the remote blower. Wire black to black, white to white and green to green or bare wire. (See Figure 2-50)
3. Replace the electrical box cover.
4. Plug the power cord of the downdraft into the outlet.

## INSTALL TOP COVER

**NOTE:** Model DD45 comes with the top cover already installed.

1. Press the UP/DOWN button on the control module.
2. Remove shipping brackets from the downdraft chimney.
3. Align the mounting brackets on the back surface of the top cover with the corner mounting positions on top of downdraft chimney.
4. Screw the top cover mounting brackets into the mounting holes on downdraft chimney with the four screws provided. Make sure that the top cover is secure and runs flush with the front edge of the downdraft.

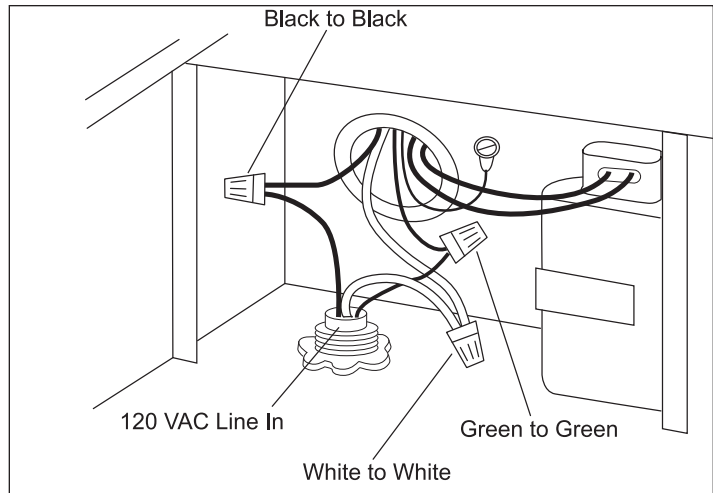

Figure 2-50 Remote Blower Connection

# SECTION 3

# CONTROLS & OPERATION

**ELECTRONIC CONTROL FOR CT HOODS**

Wolf ventilation hoods utilize a 6 button control panel with LED indicators, that is mounted along the right front edge of the unit. (See Figure 1)

The **LIGHT** button turns the halogen lights on and off, and allows the user to choose from three lighting levels, high, medium and low.

The **HIGH, MEDIUM** and **LOW** buttons control the operational speed of the remote or internal blower. An LED indicator below the button indicates the speed of blower operation.

To turn the blower off, depress the button over the illuminated LED.

The **DELAY** button activates the delay feature which allows the blower to continue running at the selected speed for programmed time period after the button is depressed.

When in Delay mode both the Delay LED and the corresponding blower speed LED will be illuminated.

If the blower is on high speed when the Delay mode is activated, the blower will continue to run at high speed for 5 minutes. The blower will then run at low speed for 5 minutes before turning off.

If the blower is on medium speed when the Delay mode is activated, the blower will continue to run at medium speed for 5 minutes. The blower will then run at low speed for 5 minutes before turning off.

If the blower is on low speed when the Delay mode is activated, the blower will continue to run at low speed for 5 minutes and then turn off.

If the **DELAY** button is depressed when the blower is off, no action will take place.

If the **DELAY** button is pressed when the unit is already in delay mode, the delay mode will be cancelled.

The **FILTER** button monitors the use of the hood. After 30 hours of use at medium speed the Filter LED will illuminate. The filters should be removed and cleaned. Depress the Filter button to reset the Filter clean LED.

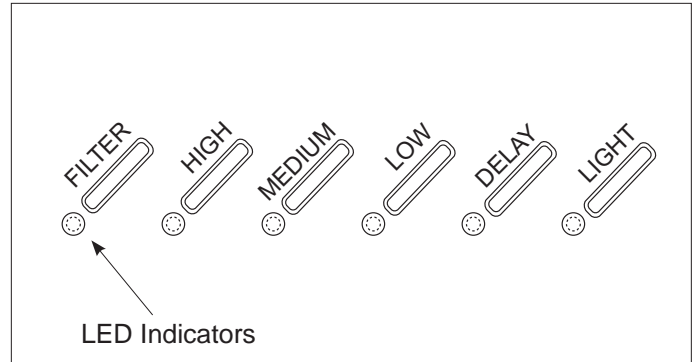

Figure 3-1 Controls (Wall and Island Hoods)

**HEAT SENTRY MODE**

Heat Sentry Mode is always in wait and is activated when exhaust temperature from hood reaches 206 F (97 C). When this temperature is reached the blower motor speed will automatically adjust to the next highest speed or turn on if the blower motor was off. The LED of the corresponding blower speed will flash on and off to indicate Heat Sentry Mode.

Once in Heat Sentry Mode, the hood will continue to monitor exhaust temperatures every three minutes. If exhaust temperature is at or exceeds 206F (97C) blower speed will be increased to the next highest speed and the corresponding LED will begin to flash. If after three minutes the exhaust temperature falls below 174F (79C), blower speed will decrease to the next lowest speed. If the blower was off prior to Heat Sentry Mode, the unit will turn off when exiting Heat Sentry Mode.

When blower speed returns to original setting prior to Heat Sentry Mode activation, the corresponding LED will stop flashing and remain constant.

### ELECTRONIC CONTROL FOR DOWNDRAFTS

Wolf downdrafts utilize a 6 button control panel with LED indicators, that is remotely mounted from the downdraft unit.

Depress the **UP/DOWN** button (See Figure 2) to raise or lower the downdraft chimney. The blower will activate at the last speed used or medium at the initial use.

**NOTE:** Figure 3-3 describes the function of the internal cam switches.

The **HIGH**, **MEDIUM** and **LOW** buttons control the operational speed of the remote or internal blower. An LED indicator below the button indicates the speed of blower operation. (See Figure 3-2)

To turn the blower off, depress the button over the illuminated LED.

The **DELAY** button activates the delay feature which allows the blower to continue running at the selected speed for programmed time period after the button is depressed.

**NOTE:** The downdraft chimney will remain in the up position when the delay mode is used.

When in Delay mode both the Delay LED and the corresponding blower speed LED will be illuminated.

If the blower is on high speed when the Delay mode is activated, the blower will continue to run at high speed for 5 minutes. The blower will then run at low speed for 5 minutes before turning off.

If the blower is on medium speed when the Delay mode is activated, the blower will continue to run at medium speed for 5 minutes. The blower will then run at low speed for 5 minutes before turning off.

If the blower is on low speed when the Delay mode is activated, the blower will continue to run at low speed for 5 minutes and then turn off.

If the **DELAY** button is depressed when the blower is off or the chimney is down, no action will take place.

If the **DELAY** button is pressed when the unit is already in delay mode, the delay mode will be cancelled.

The **FILTER** button monitors the use of the hood. After 30 hours of use at medium speed the Filter LED will illuminate. The filters should be removed and cleaned. Depress the Filter button to reset the Filter clean LED.

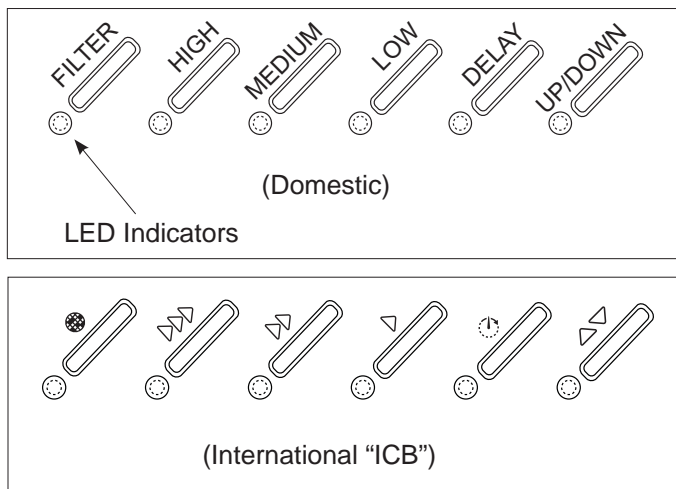

Figure 3-2 Downdraft Controls

### CLEANING

Most surfaces of Wolf ventilation hoods and downdrafts are stainless steel or aluminum. These surfaces are resistant to most stains, but are not totally impervious to damage. Salt and some cooking liquids may pit and stain these surfaces if not removed immediately.

**NOTE:** Be careful not to soak the control module. Although the control module is sealed, excessive moisture may cause damage to the electronic control.

Using a clean cloth or sponge, wipe with warm water and mild detergent. Rinse and dry immediately. Apply protective polish, always in same direction as grain.

**NOTE:** Do not use steel wool pads or abrasive cleaners; they will permanently scratch the surface.

**NOTE:** Painted surfaces should be cleaned with warm water and mild detergent only.

**Spray Degreasers:** For removing fingerprints and greasy residue. Spray on a cloth and wipe surface. Buff dry immediately to avoid streaking.

**Protective Polish:** Apply to surface to maintain luster and to protect from some food stains.

**Hard Water Stains:** Use white vinegar and water.

### FILTER CARE

Most surfaces of Wolf ventilation hoods and downdrafts are stainless steel or aluminum. These surfaces are resistant to most stains, but are not totally impervious to damage. Salt and some cooking liquids may pit and stain these surfaces if not removed immediately.

**NOTE:** Be careful not to soak the control module. Although the control module is sealed, excessive moisture may cause damage to the electronic control.

**ELECTRONIC CONTROL FOR LOW PROFILE HOODS**

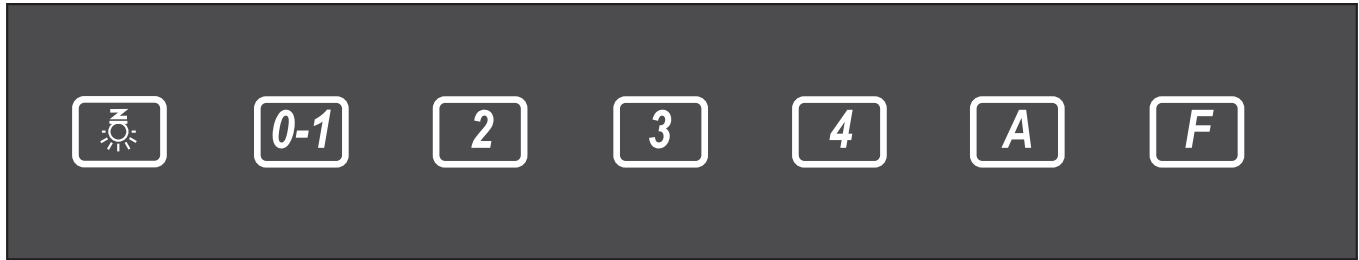









Figure 3-3 Controls For Low Profile (Wall and Island Hoods)

The Wolf cooktop low-profile hood is operated using the touch control pads on the front face of the hood. (Figure 3)

-  - LIGHTS. Touch the pad once to turn the lights ON, touch a second time to turn the lights ON to a brighter level and touch a third time to turn the lights OFF.
-  - Touch activates the blower motor at the first speed (icon is illuminated). Press the pad for about two seconds to turn the blower OFF.
-  - Activates the blower at the second speed.
-  - Activates the blower at the third speed.
-  - Activates the blower at the fourth speed.
-  - Touch the pad to set a TIMER which keeps the blower operating at the current speed for 10 minutes.
-  - FILTER. After 30 hours of operation, the icon is illuminated to indicate that the grease filter(s) must be cleaned. After 120 hours, the icon flashes to indicate that the grease filter(s) must be cleaned and the charcoal filter replaced. To reset the hour counter, touch (F) while the icon is illuminated or flashing.

SECTION 4  
COMPONENT  
ACCESS & REMOVAL

**COMPONENT ACCESS AND REMOVAL**

This section explains how to access and remove components from Wolf Pro Series ventilation products.

An attempt has been made to arrange these procedures in such a way as to simulate which components would need to be removed first in order to gain access to other components. When following a component removal procedure, it may be necessary to reference another component removal procedure listed earlier in this section.

This section is divided into two sections, the first section covers Models CTWH30, CTWH36 and Model IH4227. Section two covers Downdraft Models DD30I/R, DD36I/R and DD45I/R.

**NOTE:** Before continuing, please take note of the WARNINGS and CAUTIONS below.

**⚠ WARNING**

TO AVOID ELECTRIC SHOCK, POWER TO A VENTILATION UNIT MUST BE DISCONNECTED WHENEVER ACCESSING AND/OR REMOVING COMPONENTS POWERED BY ELECTRICITY OR COMPONENTS NEAR OTHER ELECTRICAL COMPONENTS.

IF IT IS NECESSARY TO REMOVE A VENTILATION UNIT FROM ITS INSTALLATION, REMEMBER THAT THEY ARE HEAVY AND COULD FALL RESULTING IN SERIOUS INJURY OR DEATH. PULLING A UNIT FROM ITS INSTALLATION SHOULD ONLY BE PERFORMED BY A TRAINED AUTHORIZED SERVICE TECHNICIAN OR INSTALLER.

**⚠ CAUTION**

Metal edges may be sharp. Use caution when servicing unit to avoid personal injury.



## COMPONENT ACCESS AND REMOVAL FOR MODELS CTWH & IH

### FILTER REMOVAL

**NOTE:** See **Caution** at the beginning of this section.

From the underside of wall hood, grab onto filter handle and push back against the spring retainer, then pull down and out of the wall hood. (See Figure 1)

**⚠ CAUTION**

Make sure bulb is cool before touching. Halogen bulbs get hot instantly and adjacent parts may retain heat.

Do not touch replacement bulb with bare hands. Use a paper towel or cloth when handling bulb to keep oil from fingers from touching bulb.

### HALOGEN BULB AND LIGHT ASSEMBLY REMOVAL

**NOTE:** See **Caution** above.

The halogen bulb may be removed without removing the lamp assembly. With a small flat bladed screwdriver or fingernails, pry out metal retaining clip securing the lens to the lamp assembly, using care not to damage the retainer or lens. (See Figure 2)

The halogen bulb has two metal electrodes that press into the socket of the lamp assembly.

To remove the light assembly, the filters must be removed first, then (See Figure 3):

1. Reach inside of hood cavity behind lamp assembly, depress the retaining clips and push lamp assembly through lamp-holder support.
2. Turn lamp assembly 90 degrees and slide lamp assembly through the clearance slots cut in the lamp-holder support.
3. With wire cutters, cut wire leads leading to lamp assembly.
4. Splice wires from new lamp assembly to wire harness. Use shrink wrap to seal wire splice.

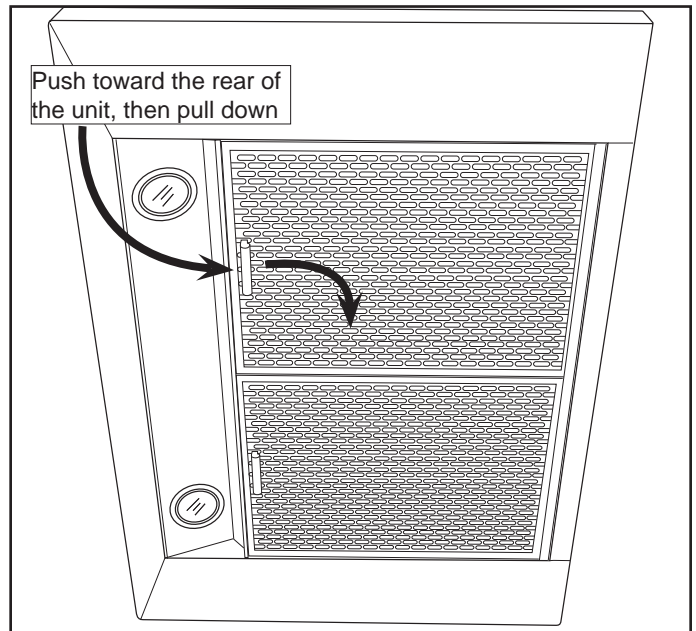

Figure 4-1 Filter Removal

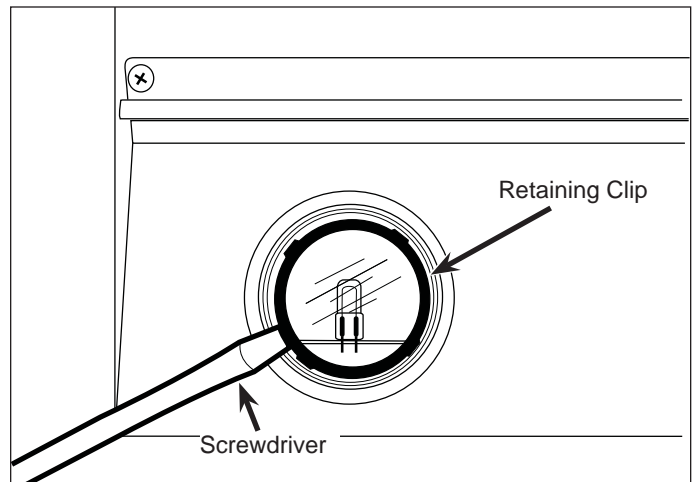

Figure 4-2 Lens Retainer Clip Removal

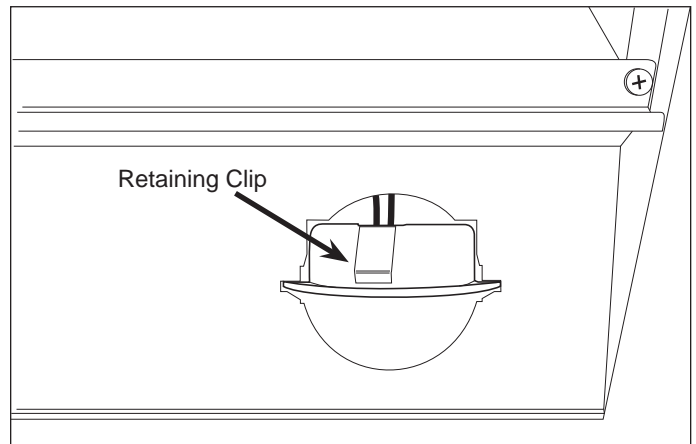

Figure 4-3 Lamp Assembly Removal

**⚠ WARNING**  
**TO AVOID ELECTRIC SHOCK, POWER TO THE VENTILATION UNIT MUST BE DISCONNECTED WHENEVER PERFORMING THE FOLLOWING REPAIRS.**

**HEAT SENTRY REMOVAL**

**NOTE:** Refer to all WARNINGS and CAUTIONS at beginning of this section.

The heat sentry is located behind the lamp-holder support and is held in place by a retaining clip.

The heat sentry will activate when the exhaust temperature reaches 206°F (97°C), signaling the blower motor to start or increase to the next highest speed. The corresponding LED will flash on and off to indicate Heat Sentry Mode.

To remove the heat sentry, the filters must be removed first, then (See Figure 4):

1. Reach inside hood cavity on backside of lamp-holder support, locate the heat sentry and pull out from under retaining clip.
2. Disconnect wire leads from heat sentry.

**LAMP-HOLDER SUPPORT REMOVAL**

The lamp-holder support provides a mounting surface for the lamp-holder assemblies and heat sentry. The front edge of the lamp-holder support has tabs that fit into slots formed in the wall hood frame, while two screws in the opposite corners secure the support to the wall hood.

To remove the lamp-holder support, the filters, heat sentry and the lamp assemblies must be removed first, (See Figure 4):

1. Extract screws from corners of lamp-holder support. (See Figure 4)
2. Pull lamp-holder support away from front edge of wall hood until tabs release from slots, and remove from unit.

**USER INTERFACE SWITCH MOUNTING BRACKET REMOVAL**

The user interface switch is mounted to a bracket that is located on the front right side of the wall hood. Screws secure the mounting bracket to the interior of the wall hood cavity.

To remove the user interface switch mounting bracket, the filters and lamp-holder support must be removed first, then (See Figures 5 & 6):

1. Extract the screws securing the user interface switch mounting bracket to the wall hood frame.
2. Pull control panel assembly out of wall hood.
3. Extract screws securing user interface switch to mounting bracket.

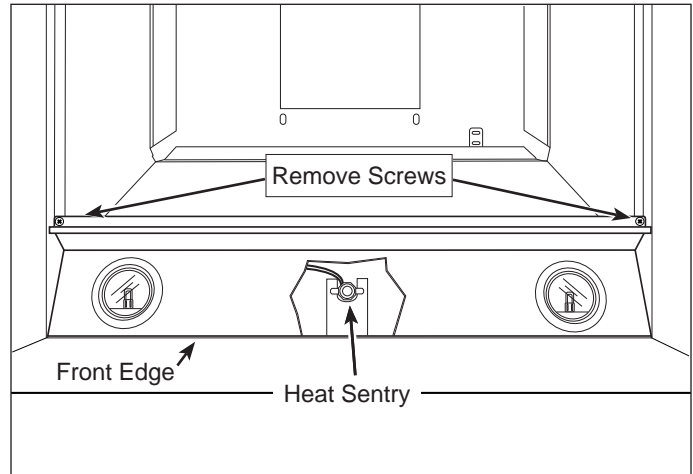

Figure 4-4 Lamp-holder Support Removal

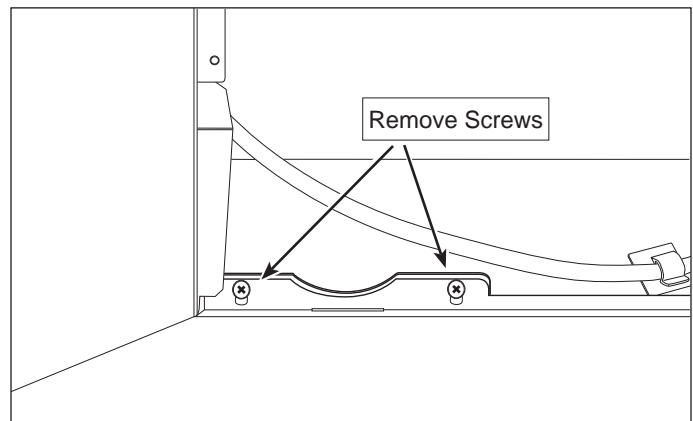

Figure 4-5 Control Panel Bracket Removal

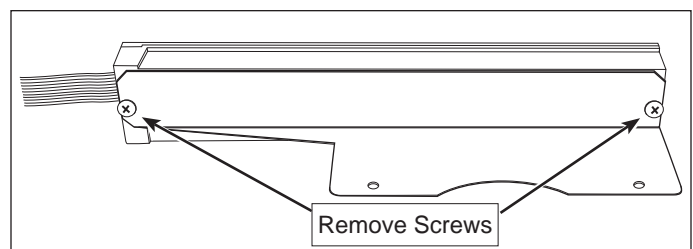

Figure 4-6 Removing Control From Bracket

**⚠ WARNING**  
**TO AVOID ELECTRIC SHOCK, POWER TO THE VENTILATION UNIT MUST BE DISCONNECTED WHENEVER PERFORMING THE FOLLOWING REPAIRS.**

### RIBBON CABLE REMOVAL

**NOTE:** Refer to all WARNINGS and CAUTIONS at beginning of this section.

The user interface switch consists of a plastic housing which contains the circuit board and push buttons, and a clear plastic plate that secures the push buttons in place and captivates the control ribbon. Screws secure the clear plastic plate to the housing.

To remove the control ribbon and/or to replace the circuit board, the filters, lamp holder support and the user interface switch mounting bracket must be removed first, then (See Figure 7):

1. Extract the screws securing the clear plastic plate to the housing.
2. Lift control circuit board out of housing.
3. With thumb and forefinger, grasp the ribbon cable connector and disconnect from circuit board.

### POWER OUTLET REMOVAL

**NOTE:** Refer to all WARNINGS and CAUTIONS at beginning of this section.

To access the power outlet the lower section of the telescoping chimney flue must be raised off of the hood and temporarily secured in place. The outlets are located on the top left front of the hood frame and are secured in place with spring clips.

To remove the power outlets, (See Figure 8):

1. Raise lower section of chimney flue off of hood frame and temporarily secure in position.
2. Disconnect electrical leads from outlet.
3. With fingers, depress spring clips on sides of outlet and push through hood frame.

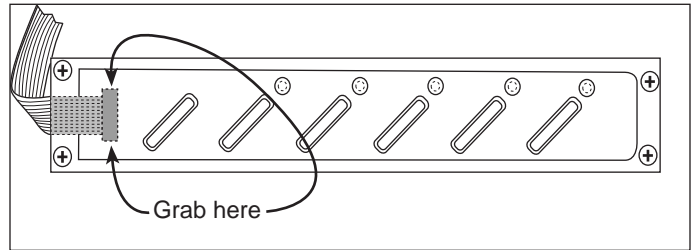

Figure 4-7 User Interface Switch Bracket Removal

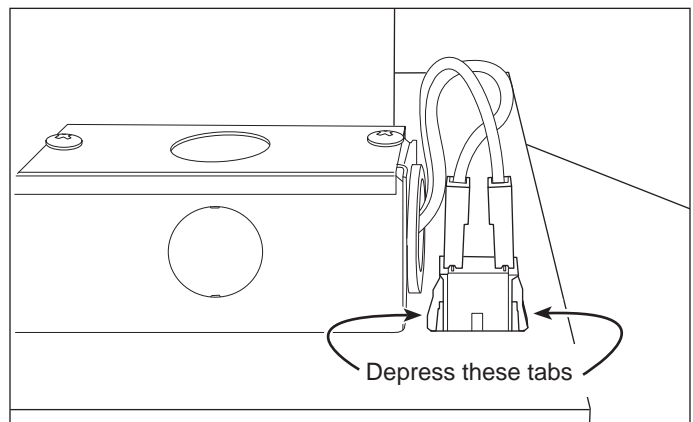

Figure 4-8 Power Outlet Removal

**⚠ WARNING**  
**TO AVOID ELECTRIC SHOCK, POWER TO THE VENTILATION UNIT MUST BE DISCONNECTED WHENEVER PERFORMING THE FOLLOWING REPAIRS.**

**TRANSFORMER REMOVAL**

**NOTE:** Refer to all WARNINGS and CAUTIONS at beginning of this section.

To access the transformer the lower section of the telescoping chimney flue must be raised off of the hood and temporarily secured in place. The transformer is located on the top right side of the hood frame and is secured to the hood with screws.

To replace the transformer, (See Figure 9 & 10):

1. Raise lower section of chimney flue off of hood frame and temporarily secure in position.
2. Extract screws securing the transformer wire cover to transformer and remove from unit.
3. With a flat bladed screwdriver, loosen set screws securing wires to transformer terminals. Pull wire leads out of transformer.
4. Extract screw from front of transformer. Slide transformer out from under mounting bracket.

**FUSE REMOVAL**

**NOTE:** Electrical shock hazard. Refer to WARNING at beginning of section.

To access the fuse the lower section of the telescoping chimney flue must be raised off of the hood and temporarily secured in place. The control box is located on the upper right side of the hood frame. The fuse is located in a fuse holder inside the control box.

To remove the fuse,

1. Raise lower section of chimney flue off of hood frame and temporarily secure in position.
2. Extract screws  securing the control panel cover to control box and remove cover. (See Figure 11)
3. Grasp top section of fuse holder with fingers and turn counterclockwise. Pull cap and fuse out of fuse holder. (See Figure 12)

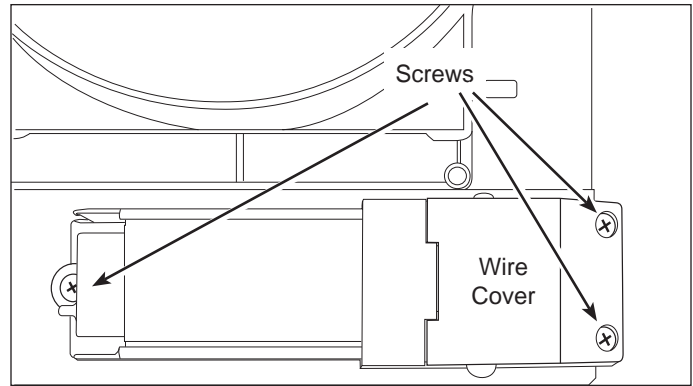

Figure 4-9 Transformer Removal

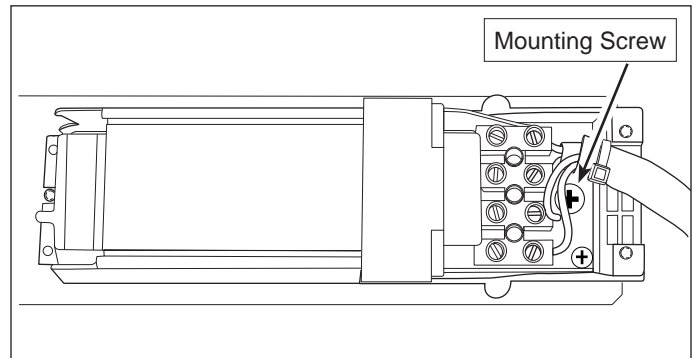

Figure 4-10 Disconnect Wire Harness

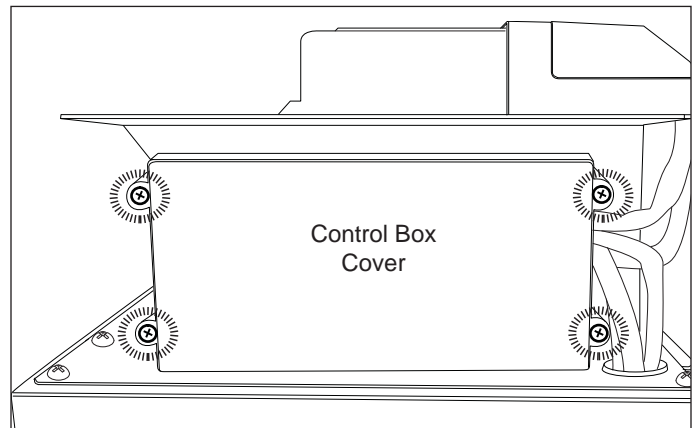

Figure 4-11 Control Box Cover Removal

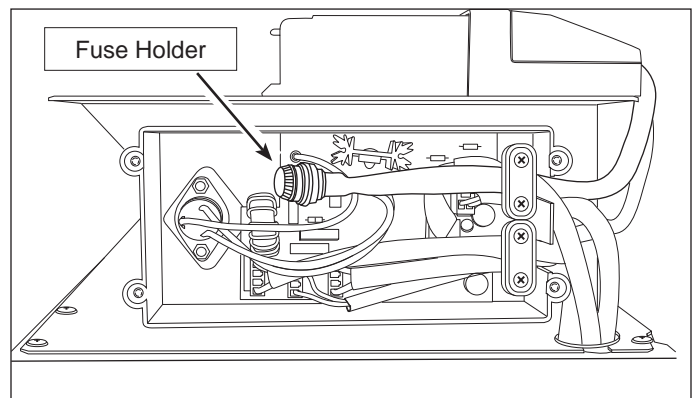

Figure 4-12 Fuse Removal

## COMPONENT ACCESS AND REMOVAL FOR MODEL CTEW

### ⚠ WARNING

TO AVOID ELECTRIC SHOCK, POWER TO THE VENTILATION UNIT MUST BE DISCONNECTED WHENEVER PERFORMING THE FOLLOWING REPAIRS.

### ⚠ CAUTION

- MAKE SURE BULB IS COOL BEFORE TOUCHING. HALOGEN BULBS GET HOT INSTANTLY AND ADJACENT PARTS MAY RETAIN HEAT.
- DO NOT TOUCH REPLACEMENT BULB WITH BARE HANDS. USE A PAPER TOWEL OR CLOTH WHEN HANDLING BULB TO KEEP OIL FROM FINGERS FROM TOUCHING BULB.

### HALOGEN BULB REMOVAL

**NOTE:** See **Caution** above.

The halogen bulb may be removed without removing the lamp assembly. With a small flat bladed screwdriver or fingernails, pry out metal retaining clip securing the lens to the lamp assembly, using care not to damage the retainer or lens. (See Figure 13)

The halogen bulb has two metal electrodes that press into the socket of the lamp assembly.

### FILTER REMOVAL

1. Lower the drop plate by pulling down on the front edge to dislodge it from the snap fasteners and allow it to hinge down and back.
2. Place one finger under the filter latch and pivot the latch forward and down until the front of the filter is allowed to freely drop out of the filter opening.
3. Lean the filter down and out of the 2 slots in the back of the filter opening. (Figure 14)

### DROP PLATE REMOVAL

1. Pull down on the front edge of the drop plate to dislodge it from the snap fasteners.
2. Using a Phillips screw driver, remove the (4) hinge screws as shown in Figure 15.

**NOTE:** To prevent damage, you will need to support the plate with one hand while removing the screws with the other.

### HOOD INNER PANEL REMOVAL

1. Remove Drop Plate and Filter(s). (See previous page)

### ⚠ CAUTION

ALWAYS WEAR GLOVES WHEN HANDLING SHEET METAL DUE TO THE POSSIBILITY OF SHARP EDGES.

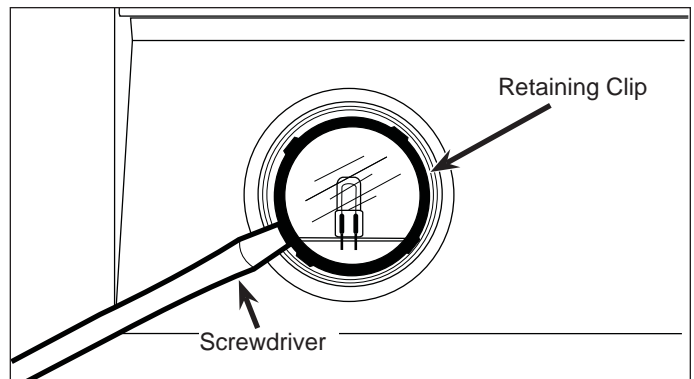

Figure 4-13 Bulb Lens Removal

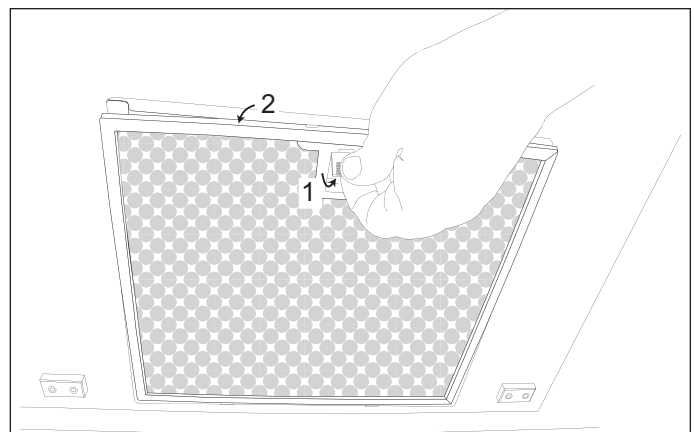

Figure 4-14 Filter Removal

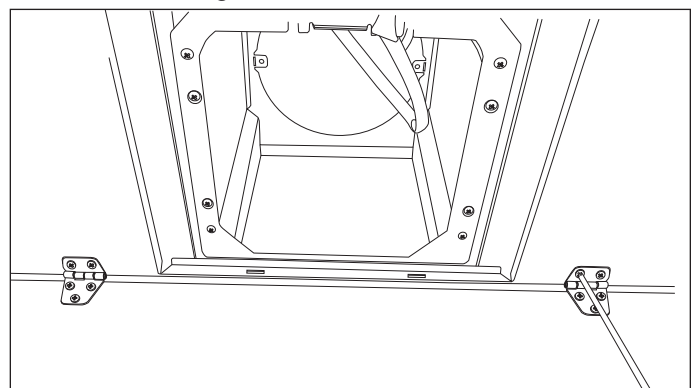

Figure 4-15 Drop Plate Hinge Screws

**HOOD INNER PANEL REMOVAL (CONT.)**

**⚠ WARNING**  
**TO AVOID ELECTRIC SHOCK, POWER TO THE VENTILATION UNIT MUST BE DISCONNECTED WHENEVER PERFORMING THE FOLLOWING REPAIRS.**

2. Locate the (3) screws fastening the front of the shroud to the hood frame. Using a Phillips screw driver, remove the screws as shown in Figure 4-16.

**NOTE:** To prevent damage, you will need to support the panel with one hand while removing the screws with the other.

3. Locate the (3) screws fastening the back of the panel to the hood frame. Using a Phillips screw driver, remove the screws as shown in Figure 17.
4. Slowly lower the panel until the molex plug for the Heat Sentry (see Figure 16) is exposed and disconnect plug.

**LAMP SOCKET REMOVAL**

1. To remove the light Socket assembly, the drop plate, filters and inner shroud must first be removed (See procedures above).
2. Disconnect Molex plug for the Lamp Socket that you are going to remove.
3. Reach inside of hood cavity above the lamp assembly and depress the retaining clips and push lamp assembly through lamp-holder support.

**NOTE:** If necessary, turn lamp assembly until you can slide lamp assembly through the clearance slots cut in opening in the hood.

**CONTROL PANEL REMOVAL**

1. To remove the Control Panel, the drop plate, filters and inner shroud must first be removed (See procedures above).
2. Disconnect Communication Cable from the back of the Control Panel. (Figure 19)
3. Locate and remove the screws that fasten the Control panel to the hood.

**NOTE:** The screws (2 for Wall Hoods, 4 for Island Hoods) are the only fasteners used to hold the Control Panel to the Hood. Control Panel will fall if not supported as screws are removed.

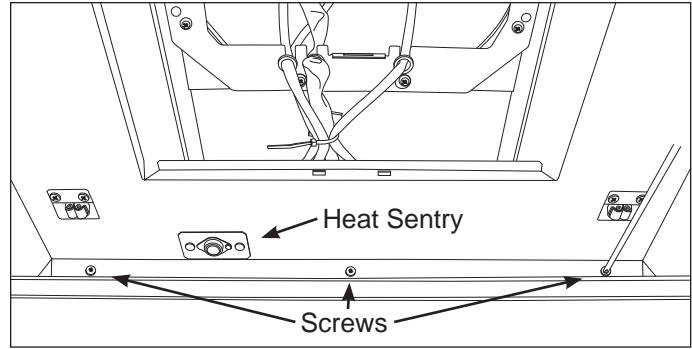

Figure 4-16 Inner Panel Front Screws

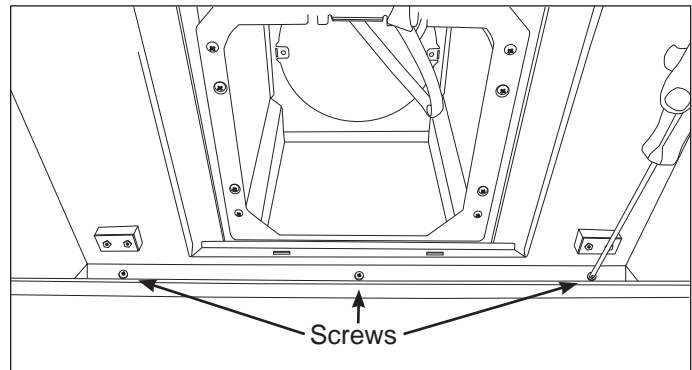

Figure 4-17 Inner Panel Rear Screws

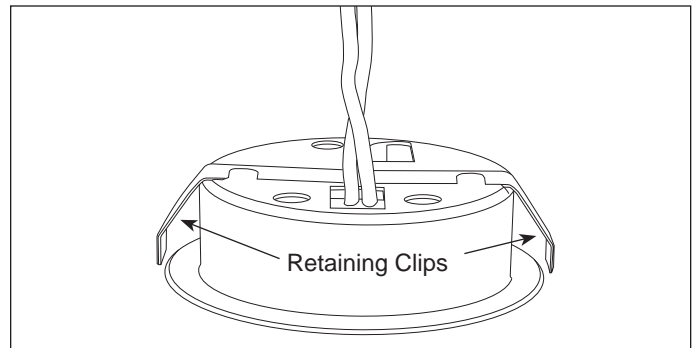

Figure 4-18 Lamp Socket

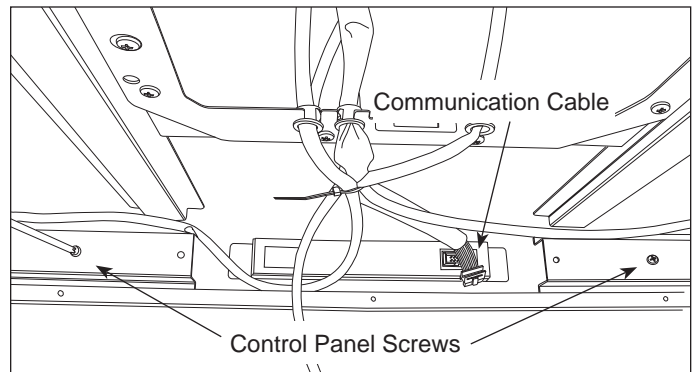

Figure 4-19 Control Panel Removal



### ⚠ WARNING

TO AVOID ELECTRIC SHOCK, POWER TO THE VENTILATION UNIT MUST BE DISCONNECTED WHENEVER PERFORMING THE FOLLOWING REPAIRS.

### ⚠ CAUTION

ALWAYS WEAR GLOVES WHEN HANDLING SHEET METAL DUE TO THE POSSIBILITY OF SHARP EDGES.

#### INTERNAL BLOWER REMOVAL

1. Disconnect electrical supply. (see WARNING above)
  - NOTE:** For Island Hood Internal Blower Removal Skip to Step 6. Motor connector located inside motor housing and should be disconnected there.
2. Slide the bottom section of chimney flue up to gain access to the controls. (See Figure 20)
3. Remove the Control Board housing cover, cable clamp and cable tie that secure the motor harness. Unplug CN1 by gripping the connector and pulling straight out. (See Figure 21)
4. Remove the nut from the grounding stud and free the blower ground wire. (See Figure 21)
5. Feed the blower wire harness and ground wire down through the wire routing hole. (See Figure 22)
6. Remove the Drop Plate and Filter(s) (Page 4-7).
7. Remove the Inner Panel.
  - NOTE:** Do not forget to unplug Heat Sentry once Inner Plate screws are removed.
8. Remove screws (4) that fasten the bottom bracket to the hood. (See Figure 4-23)

(Continued on next page)

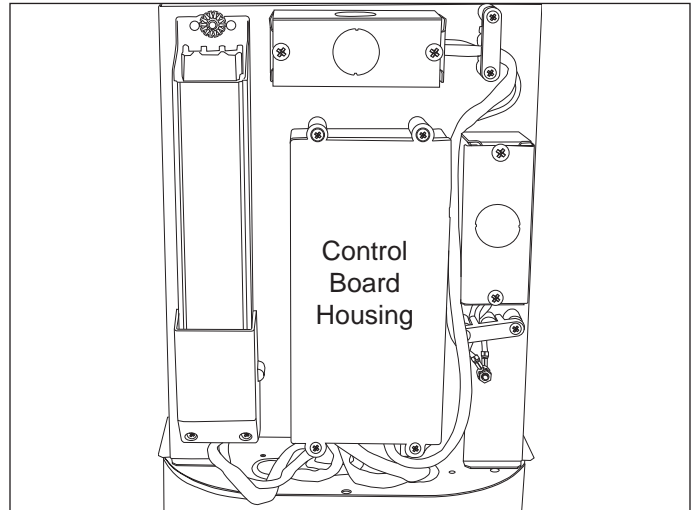

Figure 4-20 Control Panel Location

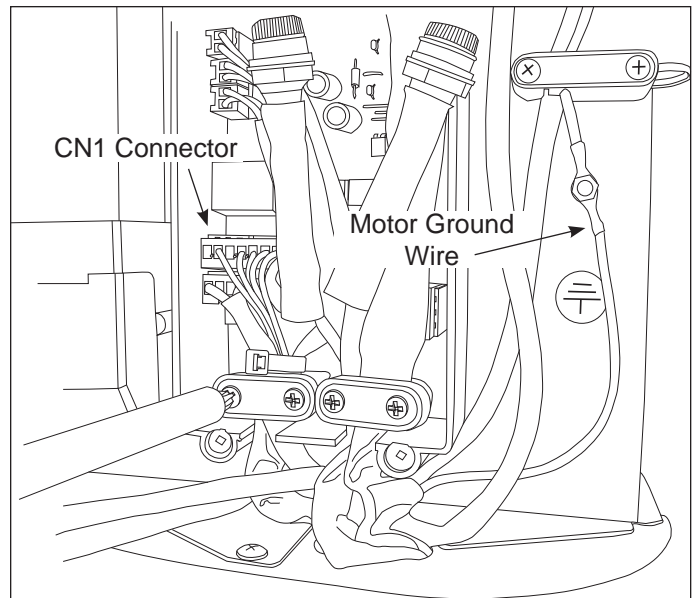

Figure 4-21 Motor Connector and Ground Wire

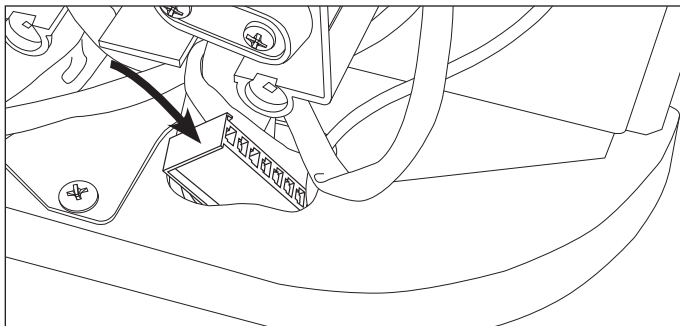

Figure 4-22 Connector

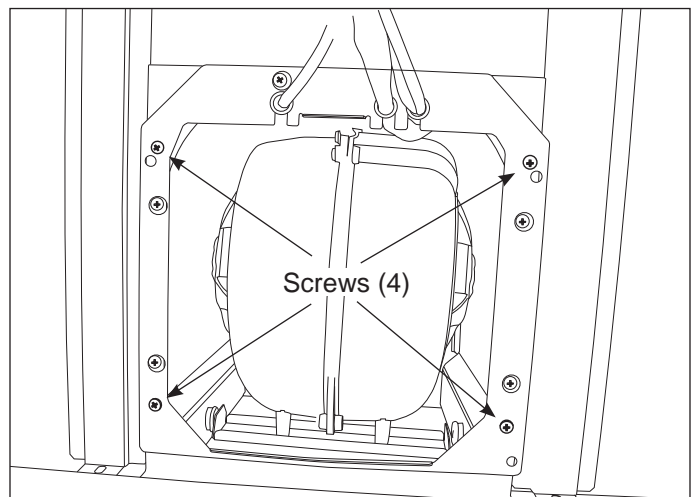

Figure 4-23 Bottom Bracket Screws

**INTERNAL BLOWER REMOVAL (CONTINUED)**

9. Remove the wing-nuts on either side of the blower housing. (See Figure 24)
10. While supporting the blower, remove the screws (Figure 25). Once the screws are removed the blower can be lowered out of the hood.

**NOTE:** You will need to rotate the blower assembly slightly within the hood to attain the correct orientation for removal.

**NOTE:** Do not lose the tubular screw spacers that are inside of the rubber mounts. These spacers prevent the possibility of crushing the rubber mount during reinstallation.

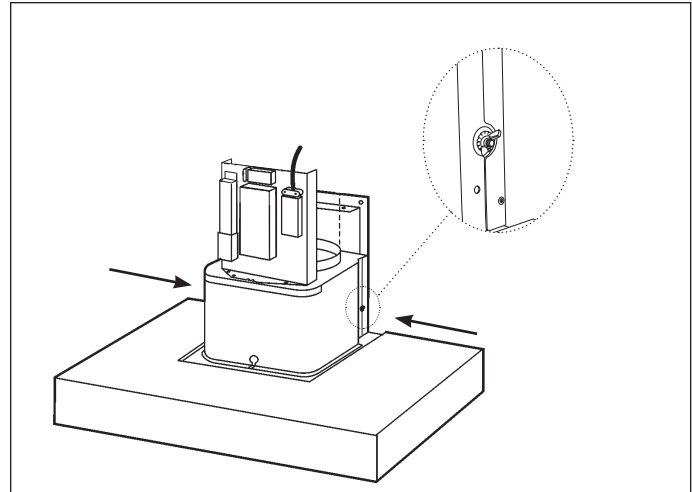

Figure 4-24 Blower Mounting Wing-nuts

**⚠ WARNING**

TO AVOID ELECTRIC SHOCK, POWER TO THE VENTILATION UNIT MUST BE DISCONNECTED WHENEVER PERFORMING THE FOLLOWING REPAIRS.

**⚠ CAUTION**

ALWAYS WEAR GLOVES WHEN HANDLING SHEET METAL DUE TO THE POSSIBILITY OF SHARP EDGES.

**CONTROL BOARD REMOVAL**

1. Disconnect electrical supply. (See **WARNING** above)
2. Slide the bottom section of chimney flue up to gain access to the controls. (See Figure 20)
3. Remove the Control Board housing cover and unplug electrical connectors.

**NOTE:** Mark wire connectors as you remove them to insure proper connection on replacement board.

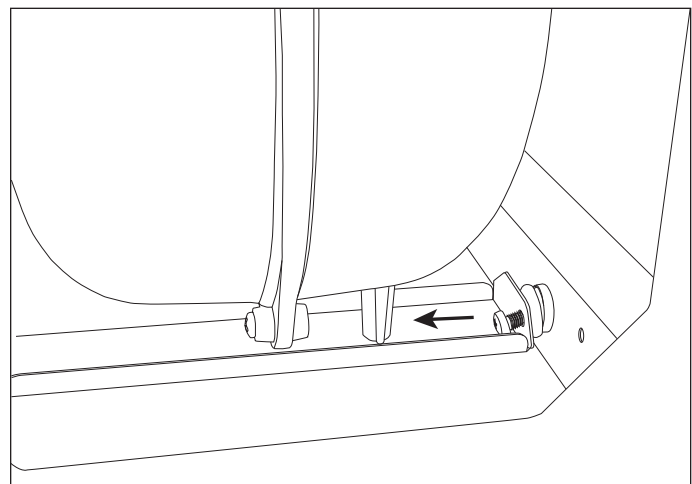

Figure 4-25 Blower Mounting Screws



### COMPONENT ACCESS AND REMOVAL FOR MODELS DOWNDRAFT UNITS

#### FILTER REMOVAL

**NOTE:** Refer to all WARNINGS and CAUTIONS at beginning of this section.

The filter assemblies are located in the chimney assembly and are secured in place by spring clips. The filter assemblies consist of two pieces, the filter grille and filter insert.

To remove the filters, (See Figure 26):

1. With chimney in the up position, push down on the filter frame while pulling the filter out away from the downdraft.
2. The filter and filter grille are separated by simply pulling the filter out of the filter grille.

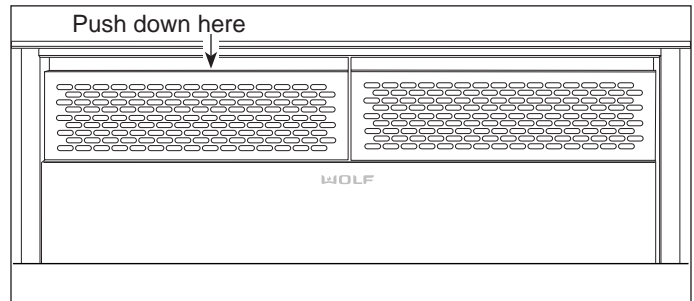

Figure 4-26 Filter Removal

**⚠ WARNING**

**TO AVOID ELECTRIC SHOCK, POWER TO THE VENTILATION UNIT MUST BE DISCONNECTED WHENEVER PERFORMING THE FOLLOWING REPAIR.**

#### INTERNAL BLOWER ASSEMBLY REMOVAL

In order to access the interior components, the blower motor assembly must be removed from its installation position. The blower motor assembly can be removed as a unit.

To remove an internal blower motor assembly, (See Figure 27):

1. Remove 3/8" (9.5) nuts from channel clamps. The channel clamps secure the cover plate and flange of internal blower assembly to the downdraft frame.
2. Extract screws securing motor cover to downdraft frame. Remove motor cover from unit.
3. Extract sheet metal screws from bottom edge of downdraft that secure the internal blower assembly to the downdraft frame.
4. Lift internal blower assembly up until flange is clear of downdraft frame. Turn internal blower assembly to side until the wire harness is accessible. Disconnect wire harness at quick disconnect.
5. Remove internal blower from unit.

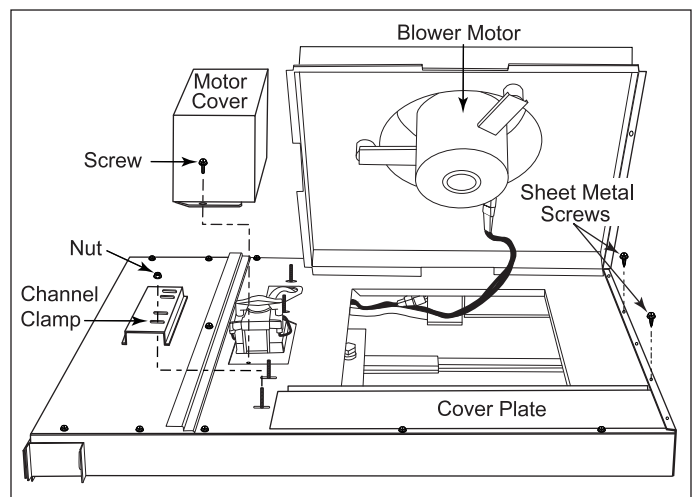

Figure 4-27 Internal Blower Assembly Removal

**⚠ WARNING**  
**TO AVOID ELECTRIC SHOCK, POWER TO THE VENTILATION UNIT MUST BE DISCONNECTED WHENEVER PERFORMING THE FOLLOWING REPAIRS.**

**BLOWER MOTOR REMOVAL**

**NOTE:** Refer to all WARNINGS and CAUTIONS at beginning of this section.

The blower motor is mounted to the scroll box assembly on three isolators and is secured with nuts. It will be necessary to remove the internal blower assembly from its installation position to remove the blower motor.

To remove the blower motor, (See Figure 28):

1. Extract screws from outside edge of scrollbox cover. Extract screws and 3/8" (9.5) nut from scroll box weldment and remove from unit.
2. Remove blower wheel by extracting setscrew securing the blower wheel to blower motor shaft.
3. From opposite side of assembly, extract 7/16" (11) nuts securing blower motor to isolators.
4. Lift motor off of isolators.
5. To remove isolators, from blower wheel side of assembly, use a 3/8" socket or wrench to extract the bolts securing the isolators to scroll box frame.

**CAPACITOR REMOVAL**

**NOTE:** Refer to all WARNINGS and CAUTIONS at beginning of this section.

The capacitor is located in the lower left hand corner of the scroll box assembly and is secured in position by a bracket and screws.

To remove the capacitor, (See Figure 29):

1. Extract screws from outside edge of scrollbox cover. Extract screws and 3/8" (9.5) nut from scroll box weldment and remove from unit.
2. Extract bolts securing capacitor bracket to scroll box assembly. Lift bracket off of capacitor.
3. Remove rubber cover from capacitor and disconnect wire leads.

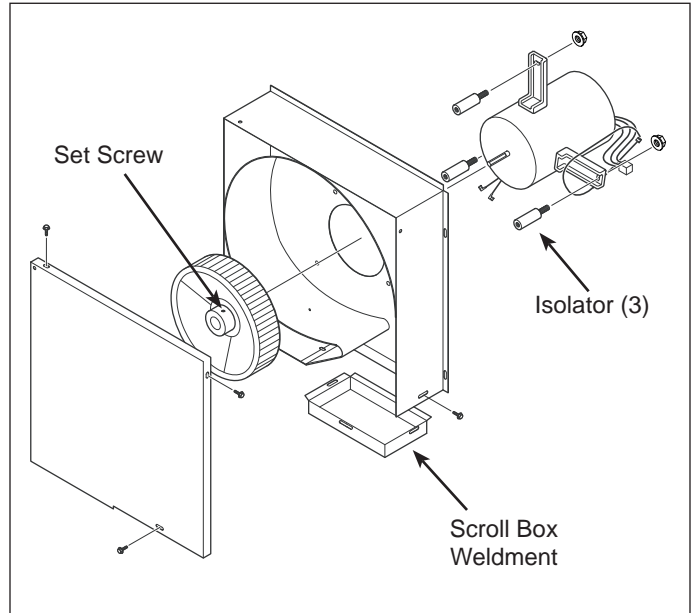

Figure 4-28 Blower Motor Removal

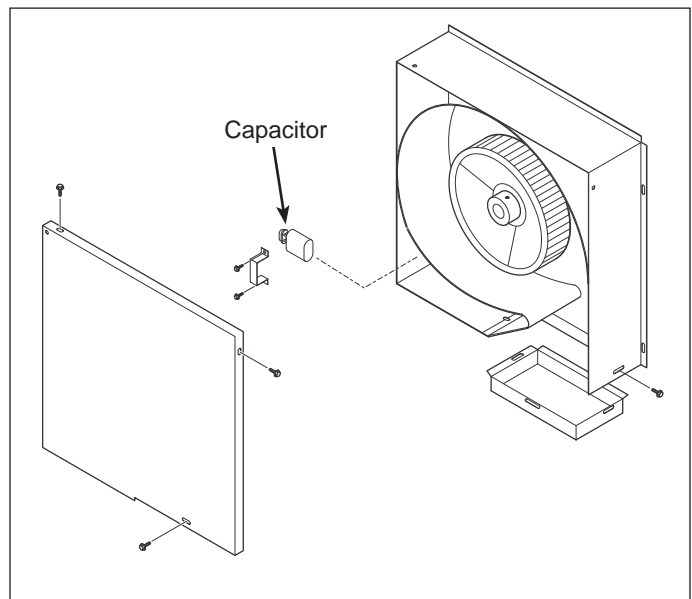

Figure 4-29 Capacitor Removal

**⚠ WARNING**  
**TO AVOID ELECTRIC SHOCK, POWER TO THE VENTILATION UNIT MUST BE DISCONNECTED WHENEVER PERFORMING THE FOLLOWING REPAIRS.**

### MICRO-SWITCH REMOVAL

**NOTE:** Refer to all WARNINGS and CAUTIONS at beginning of this section.

The micro-switches are located on the front of the gear motor and are secured to the gear motor bracket with two screws. The set of two micro-switches control the operation of the chimney assembly.

Depending on installation and cabinet size, the internal blower assembly may not have to be removed to access the micro-switches.

To remove the micro-switches, (See Figure 24):

1. If the internal blower has not been removed, remove the 3/8" (9.5) nuts from channel clamps. Lift channel clamps off threaded studs.
2. Extract screws from gear motor cover. Lift cover off of unit.
3. Disconnect electrical leads from micro-switches.



**NOTE:** The micro-switch electrical connections must be hooked up in the proper order. Take note or tag wire leads before disconnecting to assure correct location for re-assembly.

4. Extract screws from micro-switches and lift off of gear motor assembly.

### FRONT AIR BOX PANEL REMOVAL

The internal blower assembly must be removed to access the upper and lower front air box panels. Bolts secure the panels to the downdraft frame. The upper air box panel covers the filter assemblies, while the bottom air box panel covers the chimney slide assembly and electrical components.

To remove the front air box panels, remove internal blower assembly first, then (See Figure 31):

1. Extract bolts  from lower air box panel.
2. Pull lower air box cover up and away from downdraft frame and remove from unit.
3. Extract bolts  from upper air box panel, and remove panel from unit.

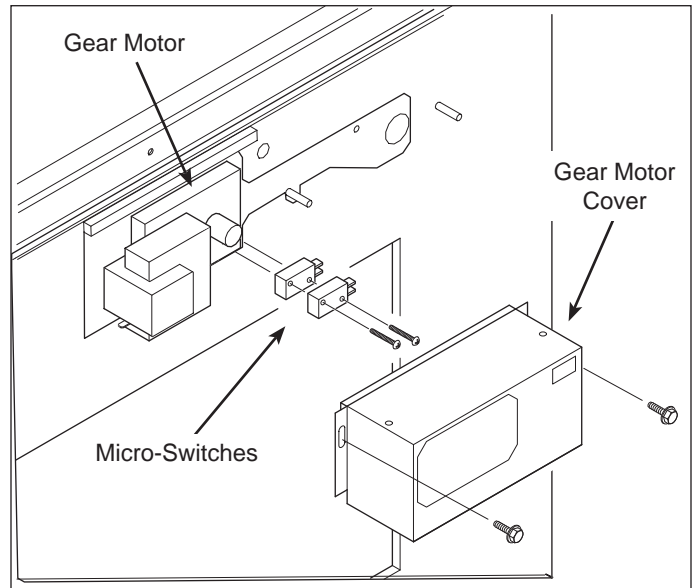

Figure 4-30 Micro-Switch Removal

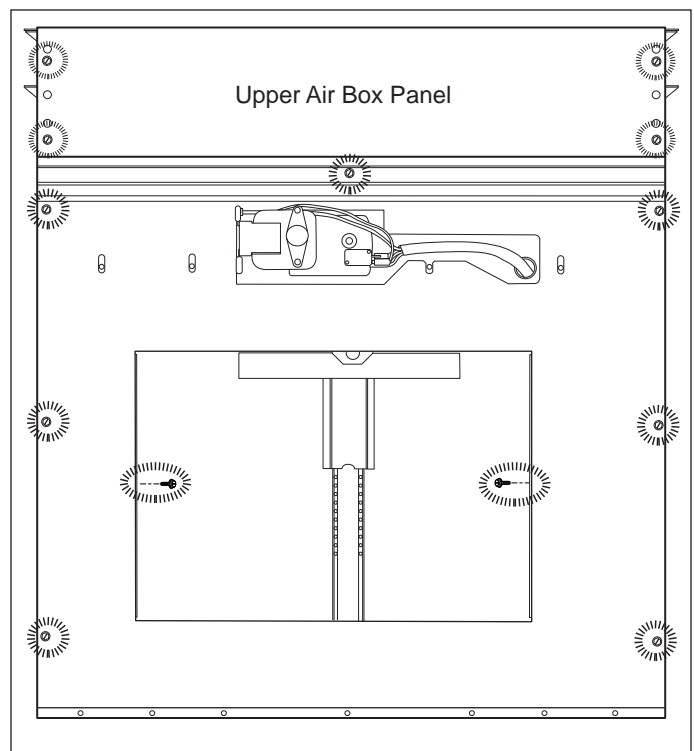

Figure 4-31 Air Box Panels Removal

**⚠ WARNING**  
**TO AVOID ELECTRIC SHOCK, POWER TO THE VENTILATION UNIT MUST BE DISCONNECTED WHENEVER PERFORMING THE FOLLOWING REPAIR.**

**GEAR MOTOR REMOVAL**

**NOTE:** Refer to all WARNINGS and CAUTIONS at beginning of this section.

The gear motor is secured with screws that pass through the back side of the gear motor bracket and fasten into the gear motor assembly. The crank assembly, which is located on the back side of the gear motor bracket, is secured to the gear motor shaft by a threaded U-shaped clamp and two nuts. The gear motor bracket is then mounted to threaded studs pressed into the unit frame and secured with 3/8" (9.5) nuts.

To remove the gear motor, the internal blower assembly and the lower air box panel must be removed first, then (See Figure 32 ):

1. Disconnect all wire leads from left side of gear motor and from micro-switches. Remove wire harness from hold down clamp then feed wire harness through gear motor bracket.
2. Extract screw securing ground wires to side of gear motor bracket.
3. With 3/8" (9.5) wrench or socket, remove nuts from both ends of gear motor bracket.
4. Lift gear motor bracket off of threaded studs.
5. From back side of bracket, remove 3/8" (9.5) nuts from U-shaped clamp securing crank assembly to motor shaft.
6. From same side of bracket, extract the screws that pass through the gear motor bracket and fasten to gear motor assembly.
7. Extract screws securing micro-switches to gear motor assembly.

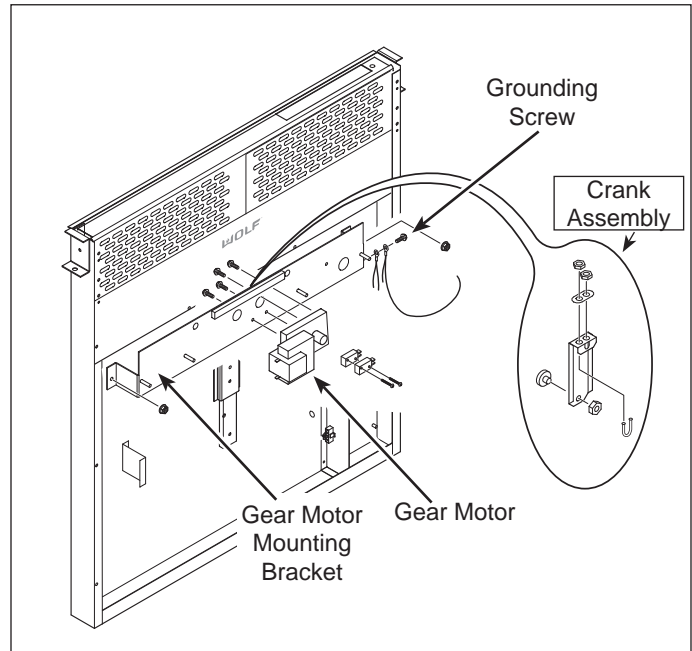

Figure 4-32 Gear Motor Removal

**⚠ WARNING**  
**TO AVOID ELECTRIC SHOCK, POWER TO THE VENTILATION UNIT MUST BE DISCONNECTED WHENEVER PERFORMING THE FOLLOWING REPAIRS.**

### POWER CONTROL BOARD REMOVAL

**NOTE:** Refer to all WARNINGS and CAUTIONS at beginning of this section.

The power control board is located inside a compartment of the bottom right hand corner of the unit interior. The board sits upon nylon spacers and is secured by nuts to the threaded studs pressed into the unit frame. Screws pass through the left compartment sidewall and fasten into an aluminum bracket riveted to the power control panel.

To remove the power control board, the internal blower assembly and the lower airbox panel must be removed first, then (See Figure 33):

1. From the left side of the power control board compartment, depress retaining clip and disconnect wire harness from power control board.
2. From same side of compartment sidewall, extract screws that fasten into the aluminum bracket of the power control board.
3. From inside compartment, using an 11/32" (8.75) socket with extension, remove nuts  from corners of power control board.
4. Lift power control board off of threaded studs.

### POWER CORD REMOVAL

**NOTE:** Electrical shock hazard. Refer to WARNING at beginning of section.

The power cord enters the unit from the right side and is held in place by a strain relief located in the right sidewall of the unit.

To remove the power cord, the internal blower assembly and lower airbox panel must be removed, then (See Figure 34):

1. Disconnect power cord from wire harness at quick disconnect.
2. From inside of unit with flat bladed screwdriver, compress and push strain relief through opening in sidewall. Pull power cord out of unit.

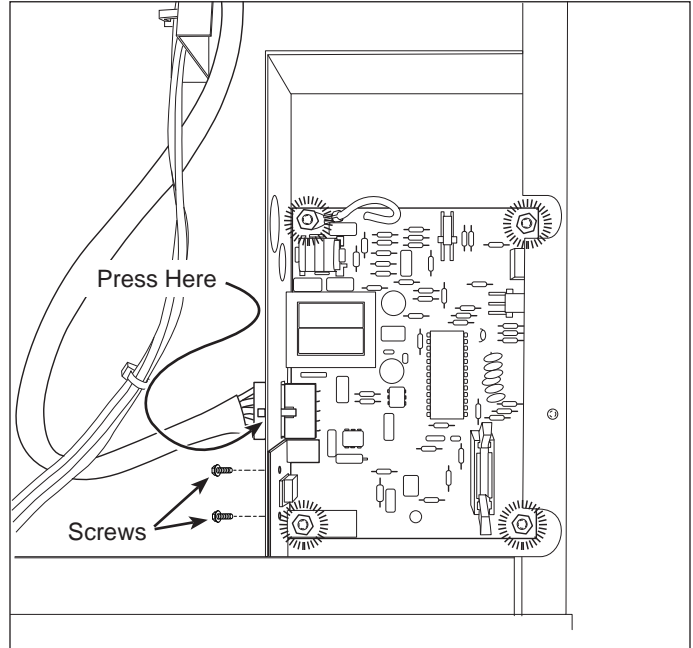

Figure 4-33 Power Control Board Removal

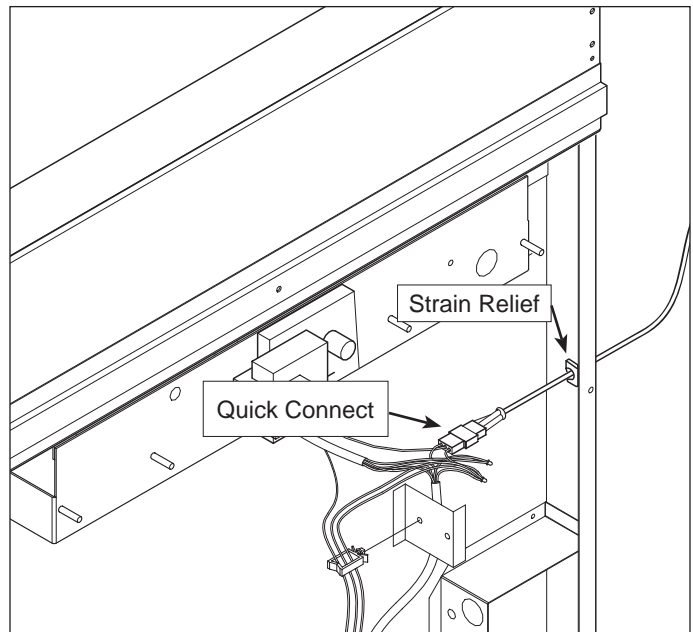

Figure 4-34 Power Cord Removal



# SECTION 5

# TROUBLESHOOTING

## INTRODUCTION

This Wolf Cooktop and Downdraft Ventilation Technical Service Manual, has been compiled with information provided by Broan-Nu Tone LLC. This manual provides the most recent technical service information that will enable the service technician to troubleshoot and diagnose malfunctions, perform necessary repairs and return a Wolf Ventilation product to proper operational condition.

The service technician should read the complete instructions contained in this Service Manual before initiating any repairs on a Wolf Appliance.

## IMPORTANT SAFETY INFORMATION

Below are the Product Safety Labels used in this manual.

The “Signal Words” used are **WARNING** & **CAUTION**.

Please note that these safety labels are placed in areas where awareness of personal safety and product safety should be taken and lists the precautions to be taken when the signal word is observed.

### **⚠ WARNING**

**TO AVOID ELECTRIC SHOCK, POWER TO A VENTILATION UNIT MUST BE DISCONNECTED WHENEVER ACCESSING AND/OR REMOVING COMPONENTS POWERED BY ELECTRICITY OR COMPONENTS NEAR OTHER ELECTRICAL COMPONENTS.**

**SOME OF THE FOLLOWING TESTS MUST BE PERFORMED WITH THE ELECTRICAL POWER TURNED ON - THESE TESTS SHOULD ONLY BE PERFORMED BY A QUALIFIED SERVICE TECHNICIAN THAT HAS BEEN TRAINED IN SAFE PRACTICES FOR DIAGNOSING LIVE ELECTRICAL CIRCUITS.**

### **⚠ CAUTION**

**Sheet metal components may have sharp edges - Gloves should be worn to protect against cuts when handling sheet metal parts.**



### VENTILATION TROUBLESHOOTING

CTWH & IH		
Symptom	Diagnostic Test	Resolution
Lights do not light	Check for incoming power to hood at CN2 (Black & White)	If no voltage reset power supply breaker
	Check Bulbs for continuity	Replace if defective
	“Light” LED illuminated on touch control with light selected.	If not illuminated replace Touch Control
	Check Lighting Fuse for continuity	Replace if defective
	Check for 120 VAC at CN3 (plugged in) with lights turned on	If no voltage replace Control Board
		If voltage present - check for 120 VAC at Lighting Transformer - if no voltage change harness
Check for 12 VAC at Lighting Transformer	If no 12 VAC replace transformer	
Blower does not shut off	Unit is above 174°F (79°C)	Allow unit to cool down.
	Remote blower wired improperly	See Wiring Section for proper connection
	Check continuity of Heat Sentry w/CN5 disconnected from Control Board.	If there is continuity replace Heat Sentry
If no continuity Replace Control Board		
Blower does not run	If internal blower - make sure blower is plugged in.	Plug blower in.
	Remote blower wired improperly	See Wiring Section for proper connection.
	Disconnect CN4 and check for motor continuity and ground	If no continuity verify wiring correct and no broken wires
		Replace motor if it is open or grounded
	LED is not illuminated on touch control of selected speed	Change touch control
Check for appropriate voltage at CN4 for selected speed w/CN4 plugged in. (see Tech Data Section)	Improper or no voltage: replace Control Board	
Hood does not move enough air	Correct Ducting installation	See Ventilation Specs for proper duct size - verify entire run is correct including wall/ roof cap
	Make-up air may be required for adequate operation	Open a window and if unit draws more then make-up air is inadequate
	Incorrect blower installed	See Ventilation Specifications

<b>Downdraft</b>		
<b>Symptom</b>	<b>Diagnostic Test</b>	<b>Resolution</b>
Periscope does not go up	No power to the unit	Plug in power cord or reset power supply breaker
	“Up/Down” LED does not illuminate on touch control	Check continuity of communication cable and replace if bad Replace Touch Control
	Gear Motor defective	Replace Gear Motor
	Defective Crank Assembly	Check U-Clamps for tightness If stripped replace Crank Assembly
	Check for 120 VAC from yellow to white at Control Board while pressing “Up/Down” on touch control	If “Up/Down” LED is illuminated but no voltage change Control Board
Periscope begins to move but will not continue to top or bottom of cycle	Defective Front Cam Switch	Replace Cam Switch
	Defective Crank Assembly	Check U-Clamps for tightness If stripped replace Crank Assembly
	Gear Motor defective	Replace Gear Motor
Periscope does not go down	No power to the unit	Plug in power cord or reset power supply breaker
	Gear Motor defective	Replace Gear Motor
	Defective Crank Assembly	Check U-Clamps for tightness If stripped replace Crank Assembly
	Periscope installed incorrectly	Reinstall Periscope
	Check for 120 VAC from yellow to white at Control Board while pressing “Up/Down” on touch control	If “Up/Down” LED is illuminated but no voltage change Control Board
Blower does not run	No power to the unit	Plug in power cord or reset power supply breaker
	Remote blower improperly wired	Check Wiring Section
	LED on touch control for selected speed is not illuminated	Check continuity of communication cable and replace if bad Replace Touch Control
	Defective blower motor	Replace motor
	Verify Rear Cam Switch is dropping into Cam valley at top of periscope movement	Replace Gear Motor assembly w/switches
	Rear Cam Switch not providing 120 VAC to orange wire w/ periscope at top of movement and switch in valley	Replace Rear Cam switch
	120 VAC not present from Orange to White at Control Board w/ periscope up	Replace Control Board

<b>Low-Profile</b>		
<b>Symptom</b>	<b>Possible Cause</b>	<b>Action Required</b>
Fan does not operate with switch on.	No power to the unit	Plug in power cord or reset power supply breaker
	Defective Control Board	Check for Voltage at CN1 terminals on Cntl Brd
	Defective Fan Motor	Check Continuity of Fan Motor - Replace if defective.
	Defective Wiring	Replace Wire Harness
Fan runs but does not move enough air.	Improper Installation	Verify that duct was properly sized and no obstructions are present
		Verify tape was removed from damper during installation
		Verify a compatible Wolf blower is installed
		Verify adequate make-up air present
	Filters are soiled	Clean or Replace Filters
	Defective Control Board	Verify correct voltage output at control board
Lights do not work.	Defective Bulb	Check bulb for continuity and place if defective
		Replace bulb with known good bulb
	Defective Fuse	Check fuse for continuity and place if defective
		Replace fuse with known good bulb
	Defective Control Board	Verify voltage output at board and replace board if voltage not present
Fan cycles on and off.	Motor overheating	Check for obstructions in ducting or fan blade obstructions
	Defective Control Board	Verify if voltage at Control Board is cycling at same rate - replace if it is cycling.

**DOWNDRAFT CAM SWITCH FUNCTIONALITY**

PERISCOPE POSITION	FRONT SWITCH	CONTROL RESPONSE	BACK SWITCH	CONTROL RESPONSE
FULLY DOWN		Control is waiting for <UP/DOWN> button to be pushed No Rotation		Control is waiting for <UP/DOWN> button to be pushed Blower is off
MOVING UP		<UP/DOWN> was hit and control keep Rotation on until this switch is activated		<UP/DOWN> was hit but blower stays off.
ALMOST UP		This switch keeps Rotation Motor on until Periscope is fully up.		This switch will turn on Blower Motor when Periscope reaches the top.
FULLY UP		Control is waiting for <UP/DOWN> button to be pushed No Rotation		Control is waiting for <UP/DOWN> button to be pushed Blower stays on.
MOVING DOWN		<UP/DOWN> was hit and control keep Rotation on until this switch is activated		<UP/DOWN> was hit and this switch gets depressed shutting of Blower.
ALMOST DOWN		This switch keeps Rotation Motor on until Periscope is fully down.		This switch keeps Blower Motor off until Periscope is fully up again.

Figure 5-1 Downdraft Cam Switch Operation

### Downdraft Seal Damage Flow Chart

Complaint of discolored front trim panel and or report of pulling flames toward the downdraft.

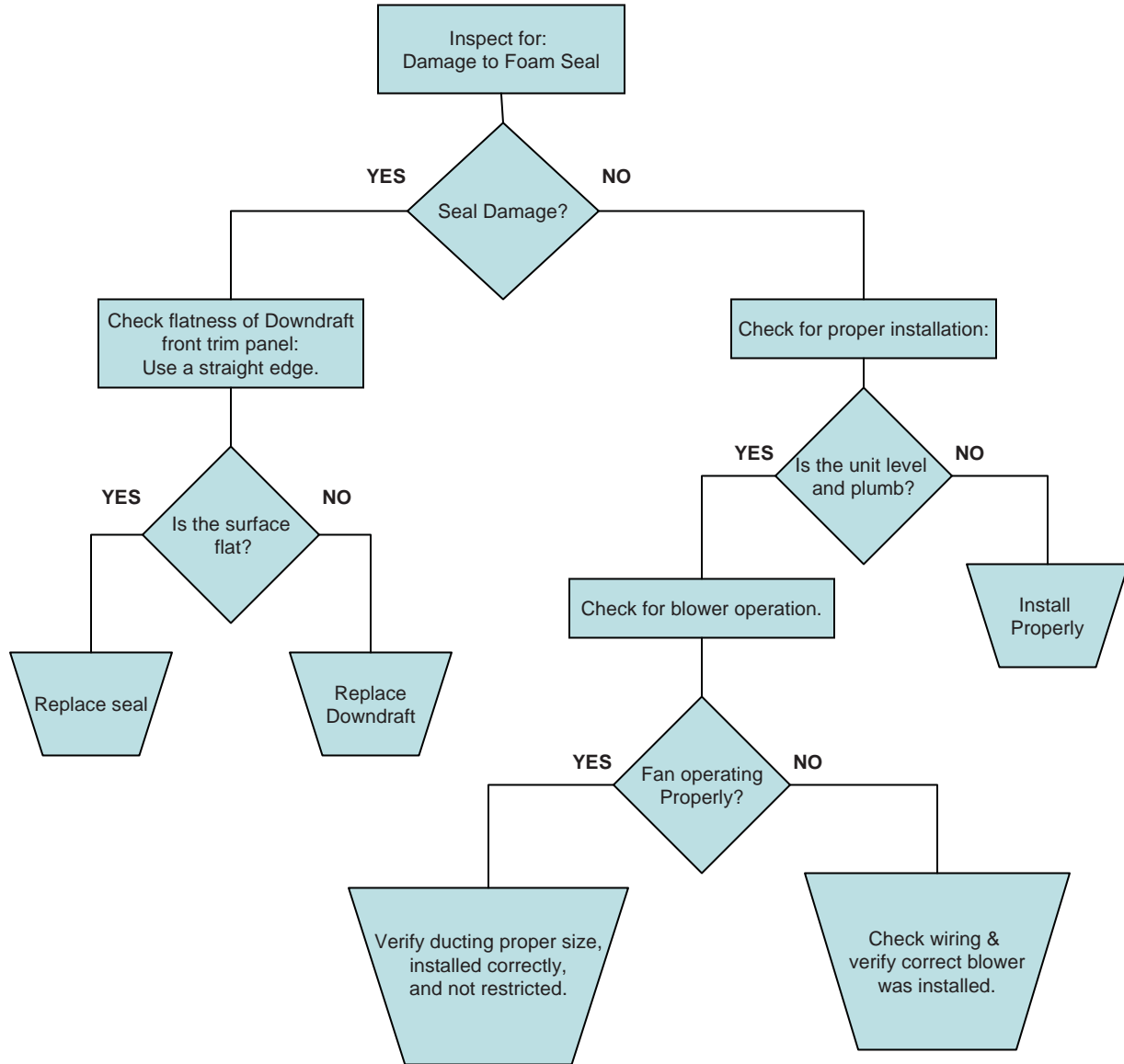



# SECTION 6

# TECHNICAL DATA

**⚠ WARNING**

**TO AVOID ELECTRIC SHOCK, POWER TO A VENTILATION UNIT MUST BE DISCONNECTED WHENEVER ACCESSING AND/OR REMOVING COMPONENTS POWERED BY ELECTRICITY OR COMPONENTS NEAR OTHER ELECTRICAL COMPONENTS.**

**⚠ CAUTION**

**Metal edges may be sharp. Use caution when servicing unit to avoid personal injury.**

## Supply Voltage Requirements

Model CTWH ..... 120 VAC / 60 Hz. / 15 amp  
 Model IH ..... 120 VAC / 60 Hz. / 15 amp  
 Model DD ..... 120 VAC / 60 Hz. / 15 amp  
 Model ICBDD ..... 240 VAC 50/60Hz. / 10 amp  
 Model CTEW & CTEI ... 120 VAC/ 60Hz. / 15 amp

## Temperature Parameters

Heat Sentry Activation Temperature:

Closes 206°F (97°C)  
 Opens - 174°F (79°C)

## Component Output Levels Domestic CT Hoods &amp; Downdraft

Speed Control: Low: 68+/-5 VAC-RMS  
 Medium: 80+/-5 VAC-RMS  
 High: 116 VAC-RMS, Minimum

Lighting Transformer	Primary	Secondary
Low .....	30 VAC	3 VAC
Medium .....	60 VAC	6 VAC
High .....	120 VAC	12 VAC

DD 500 Cfm Internal Blower Rating: 4.0 amps

## Speed Output Levels ICBDD

Speed Control (50Hz): Low: 97+/-10 VAC  
 Medium: 121+/-10 VAC  
 High: 230 VAC, Minimum

Speed Control (60Hz): Low: 137+/-10 VAC  
 Medium: 158+/-10 VAC  
 High: 230 VAC, Minimum

## CTE Low Profile Hoods Fuse Specifications

Function	Location	Rating
12V Control .....	Control Board .....	250V 4amp
Lighting .....	Harness Fuse Holders .	250V 630mA



### Speed Output Levels CTE Low Profile Hoods

Speed Control: Level 1: 63 +/-3 VAC  
 Level 2: 69 +/-3 VAC  
 Level 3: 78 +/-3 VAC  
 Level 4: 114 +/-3 VAC

**NOTE:** Measured at Power Board (Printed Circuit Board) motor connector

### Component Output Levels CTE Low Profile Hoods

Component (command level)	Control Board Test Point	Wire Color (if applicable)	Expected Voltage Reading @ 120V/60Hz	Expected Amperage Reading @ 120V/60Hz
Transformer Primary (stand-by)	CN6	n/a	120V	0.29A
Transformer Secondary (stand-by)	CN5	n/a	13.08V	0.03A
Input Power (stand-by)	CN7	n/a	120V	0.29A
Halogen Lamp (1/2 light)	CN3	n/a	6.25V	2.18A
Halogen Lamp (max light)	CN3	n/a	11.44V	11.44A
Halogen Lamp (1/2 light)	CN2	n/a	6.25V	2.18A
Halogen Lamp (max light)	CN2	n/a	11.44V	11.44A
Blower Output (speed 4)	CN1	Red/Black	120V	2.78A
Blower Output (speed 3)	CN1	Red/Orange	120V	2.72A
Blower Output (speed 2)	CN1	Red/White	120V	2.26A
Blower Output (speed 1)	CN1	Red/Blue	120V	1.88A



SECTION 7  
WIRING DIAGRAMS  
& SCHEMATICS

**MODEL CTWH30 WIRING DIAGRAM**

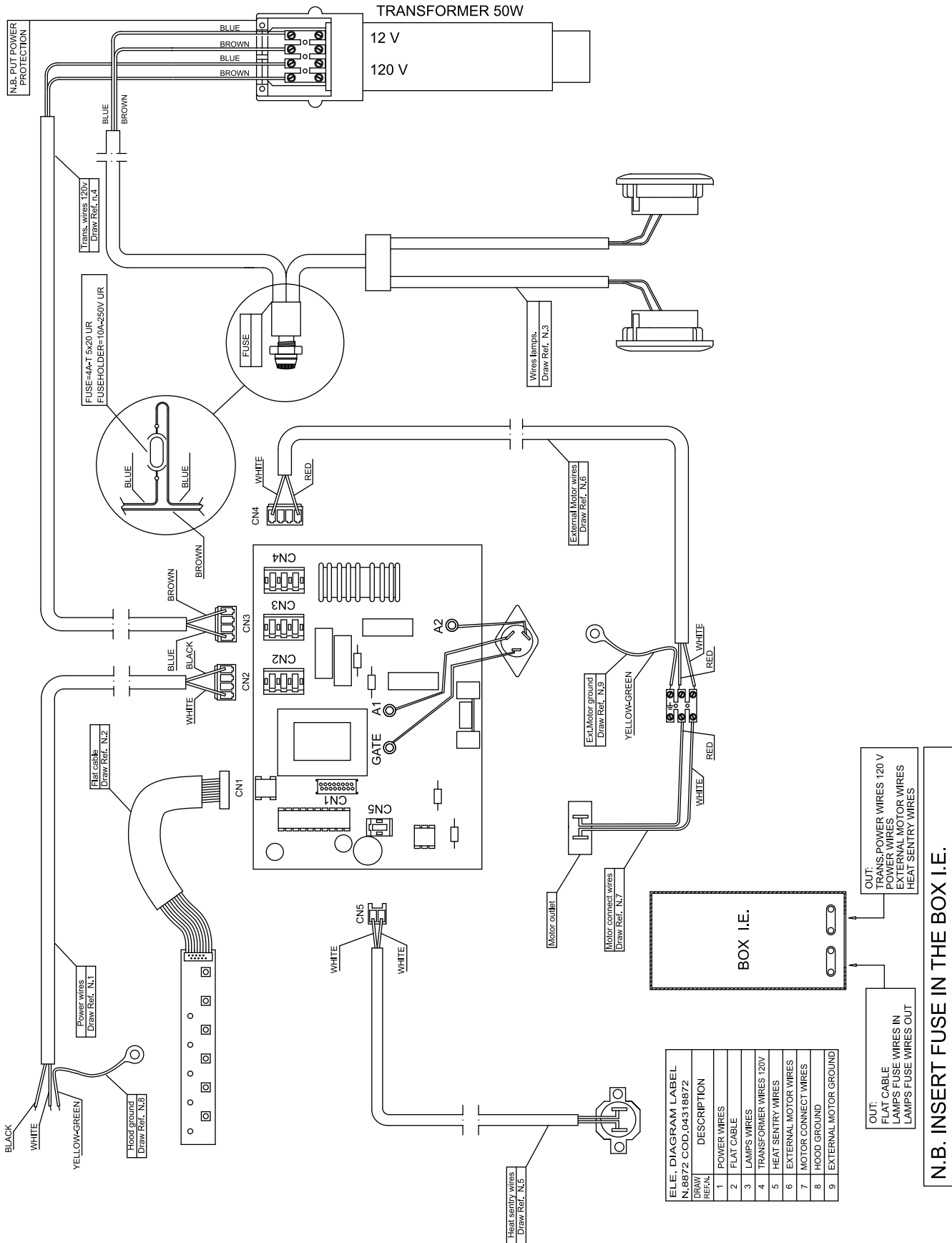

## MODEL CTWH36 WIRING DIAGRAM

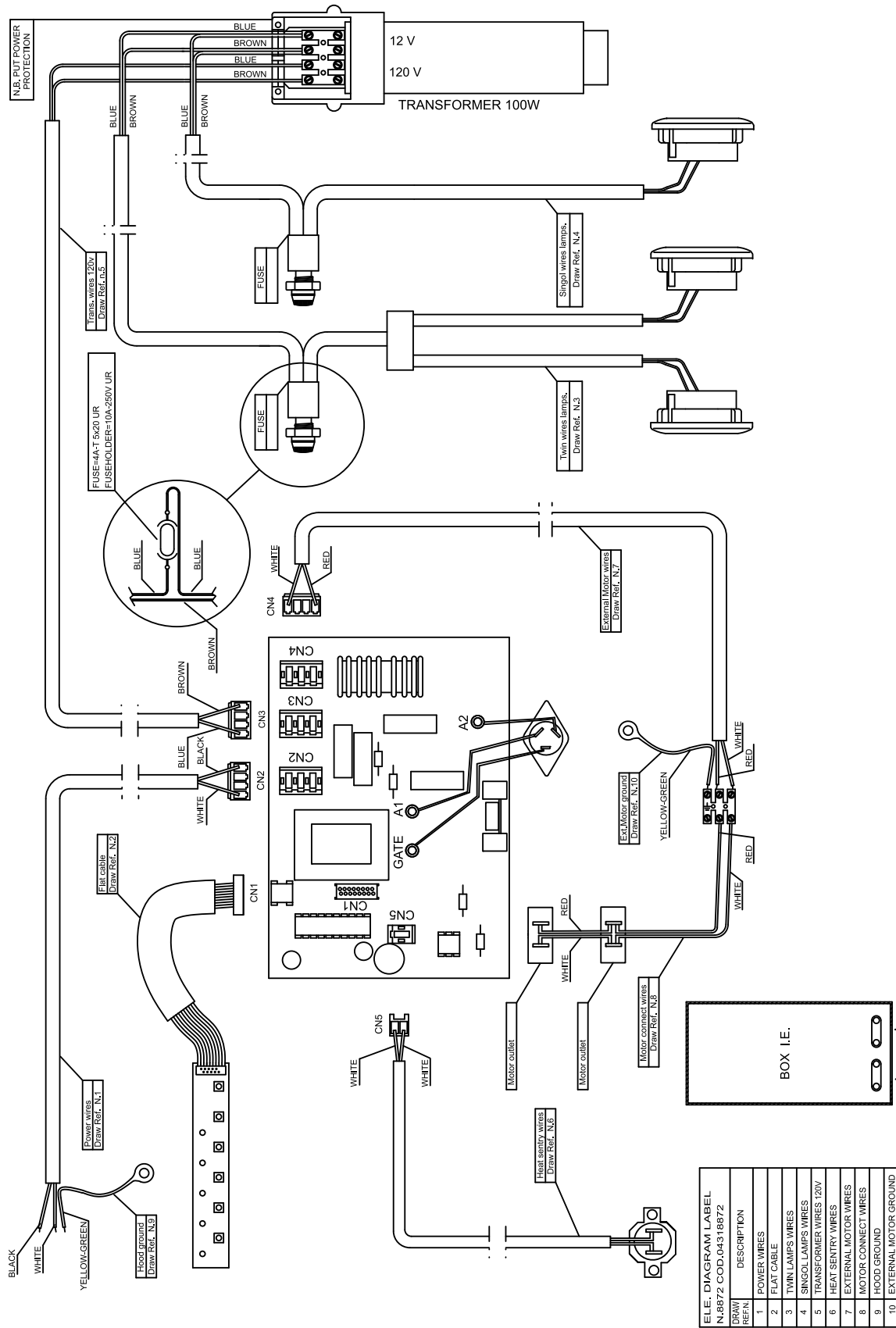

ELE. DIAGRAM LABEL  
N.8872 COD.04318872

DRAW REF.N	DESCRIPTION
1	POWER WIRES
2	FLAT CABLE
3	TWIN LAMPS WIRES
4	SINGOL LAMPS WIRES
5	TRANSFORMER WIRES 120V
6	HEAT SENTRY WIRES
7	EXTERNAL MOTOR WIRES
8	MOTOR CONNECT WIRES
9	HOOD GROUND
10	EXTERNAL MOTOR GROUND

OUT: TRANS. POWER WIRES 120 V  
FLAT CABLE  
LAMPS WIRES IN  
EXTERNAL MOTOR WIRES  
LAMPS FUSE WIRES OUT

**N.B. INSERT FUSE IN THE BOX I.E.**

**MODEL IH4227 WIRING DIAGRAM**

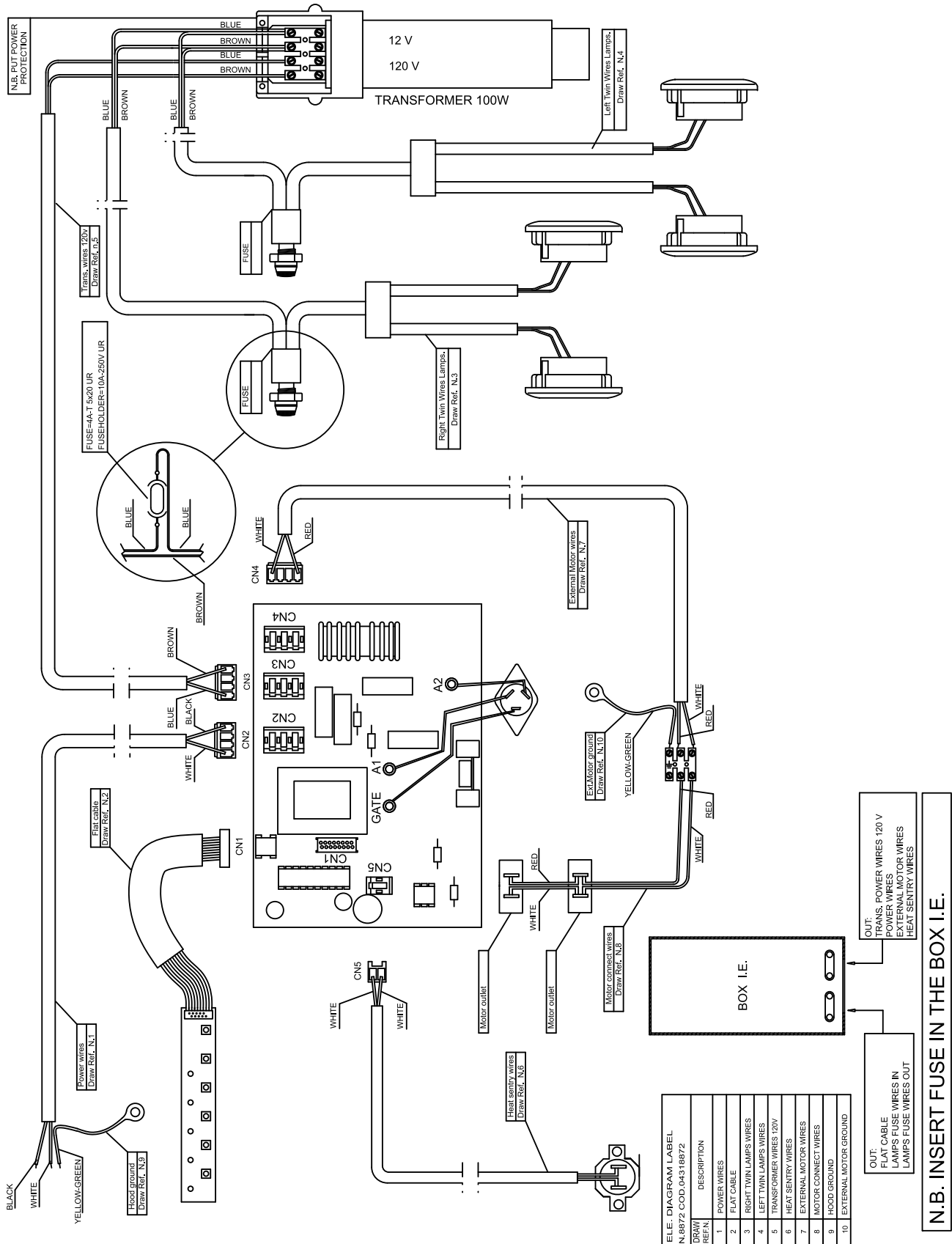

MODEL CTE LOW PROFILE HOOD WIRING DIAGRAM

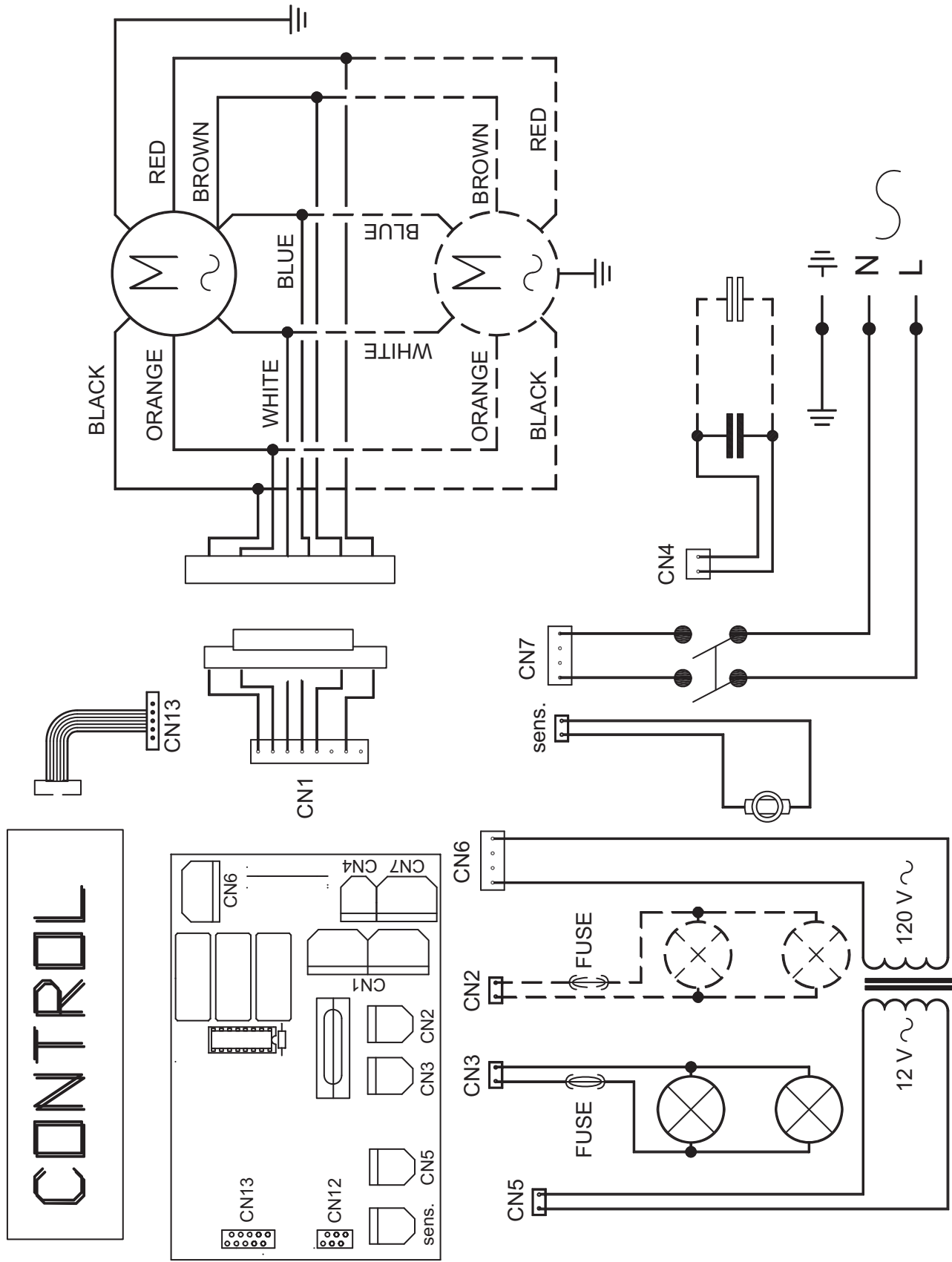

**MODEL DD30 & DD36 SCHEMATIC**

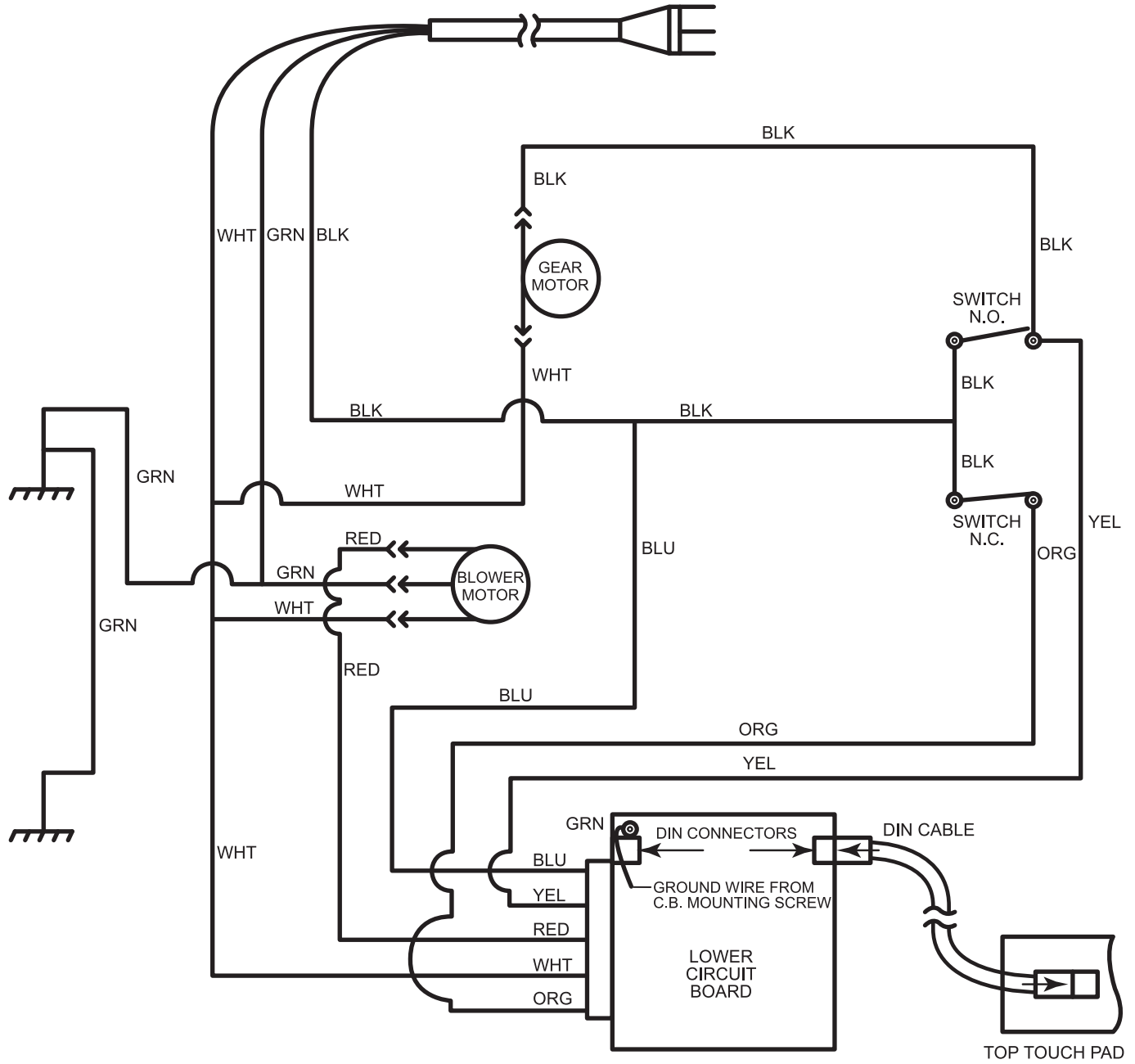

**DOWNDRAFT WIRING DIAGRAM**



## MODEL DD30 & DD36 WIRING DIAGRAM

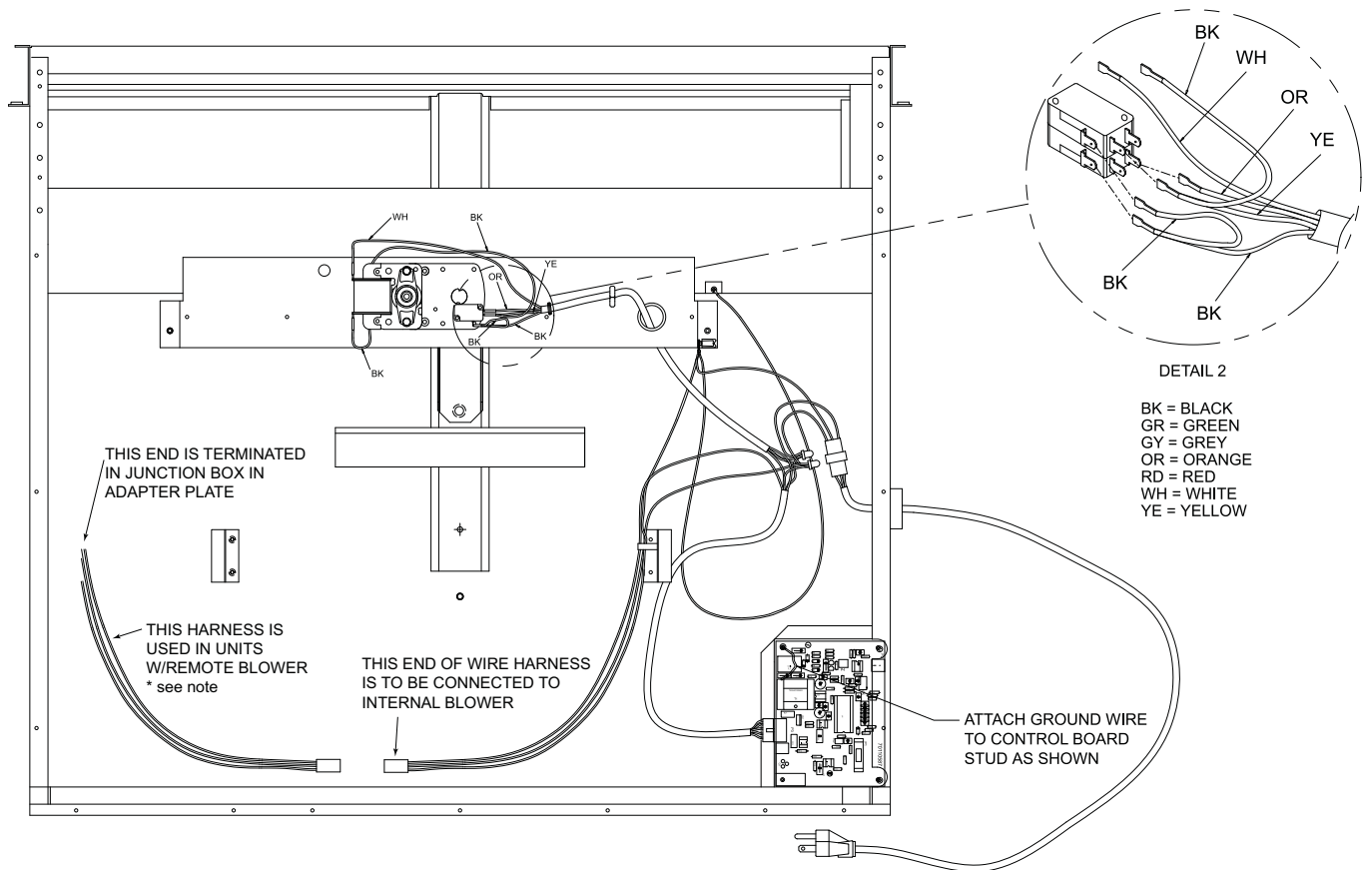

### DOWNDRAFT WIRE DIAGRAM

\* NOTE: Remote Blower harness contains a black wire that connects to a red wire in the internal blower harness.

**MODEL ICBDD30, ICBDD36 & ICBDD45 SCHEMATIC**

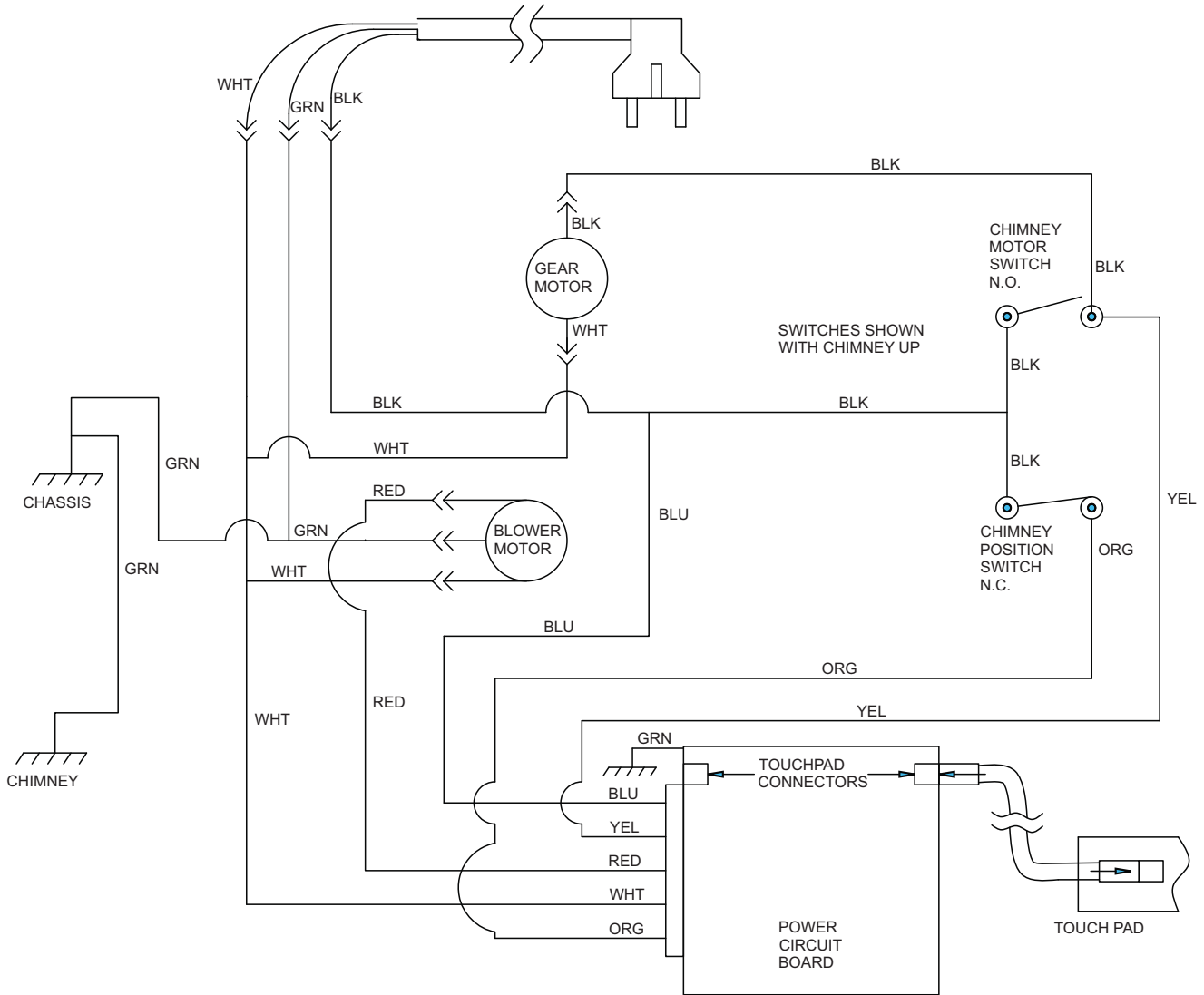

## MODEL ICBDD30, ICBDD36 & ICBDD45 WIRING DIAGRAM

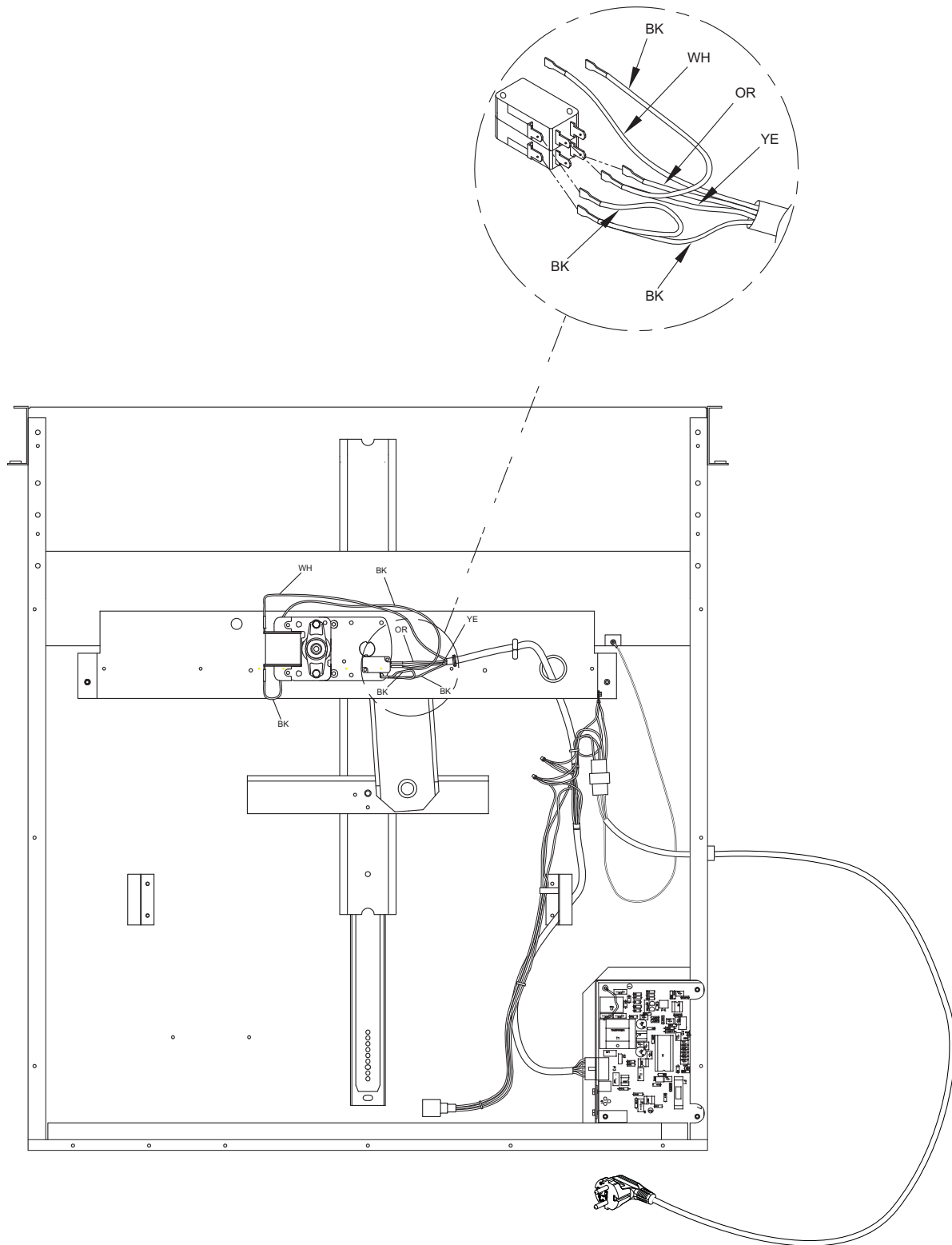

**MODEL DD30 & DD36 CONTROL SCHEMATIC**

**8 POSITION RJ45**

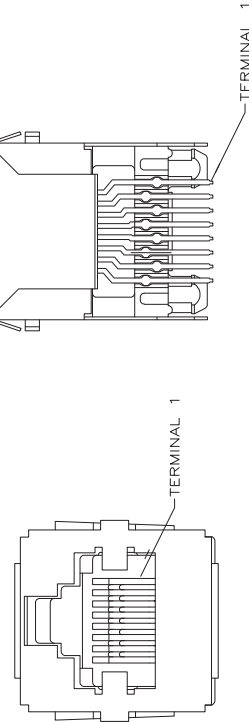
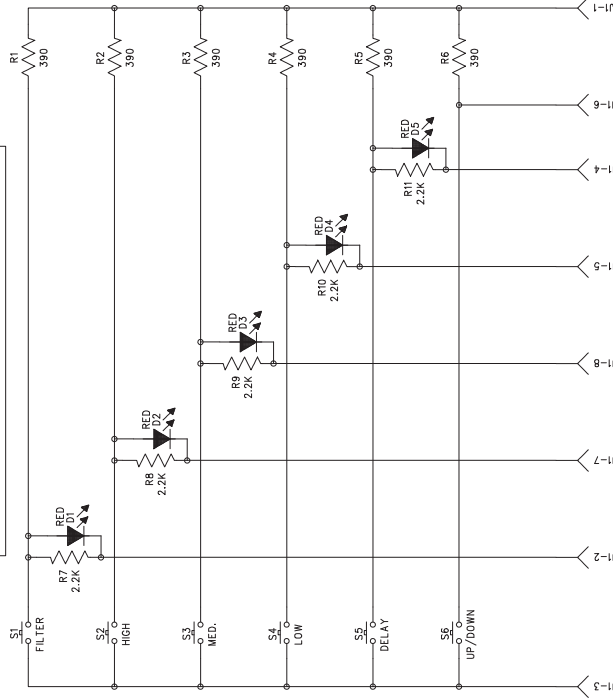
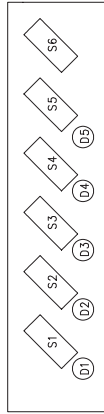

**8 POSITION MINI DIN**

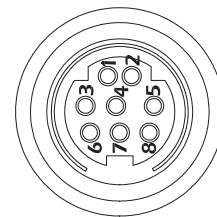
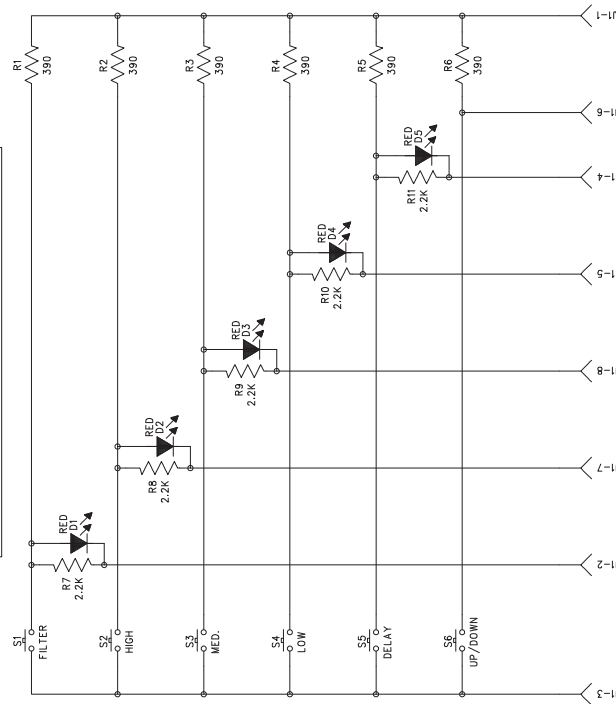
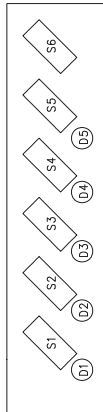

### MODEL DD POWER SUPPLY WIRING

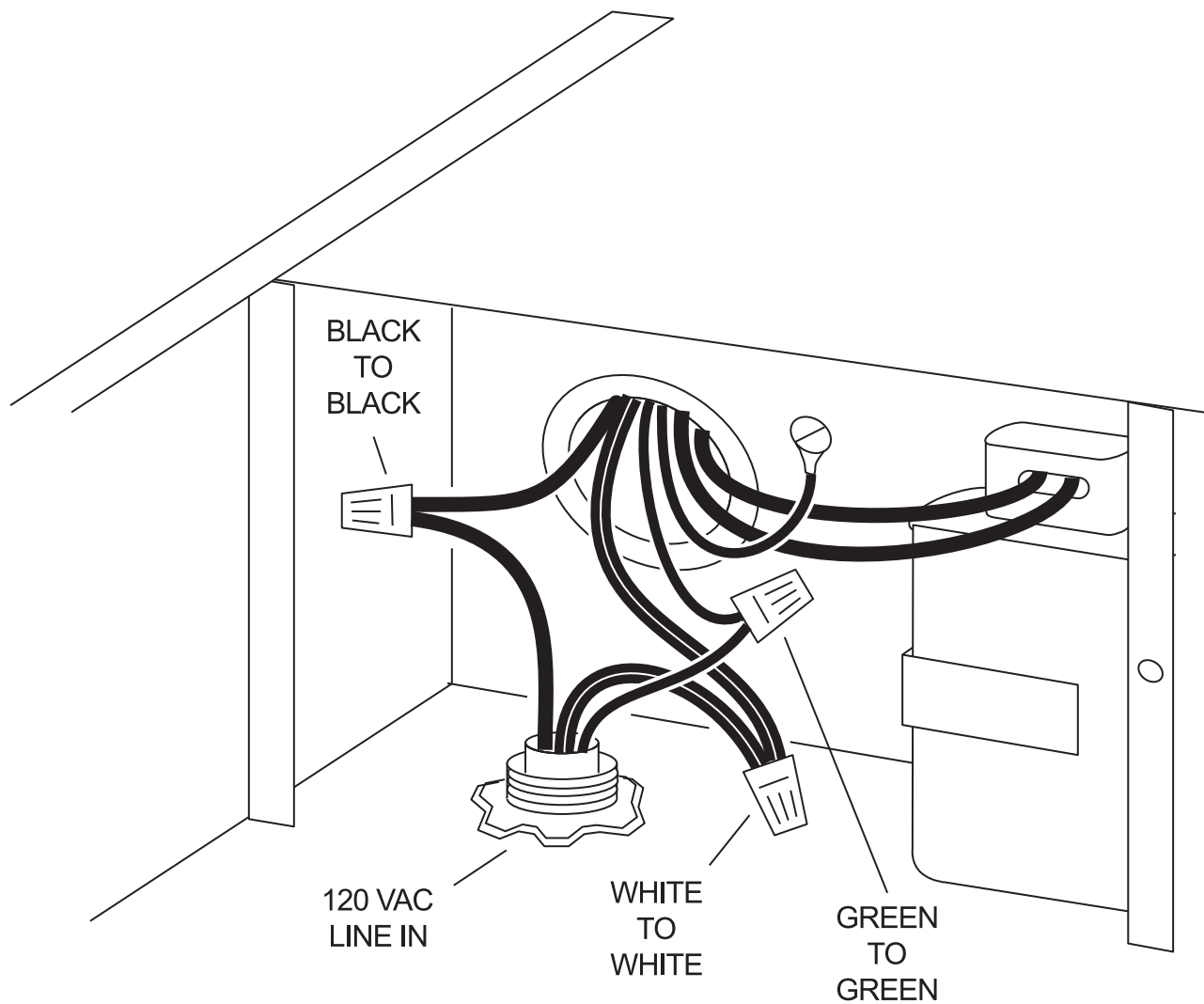

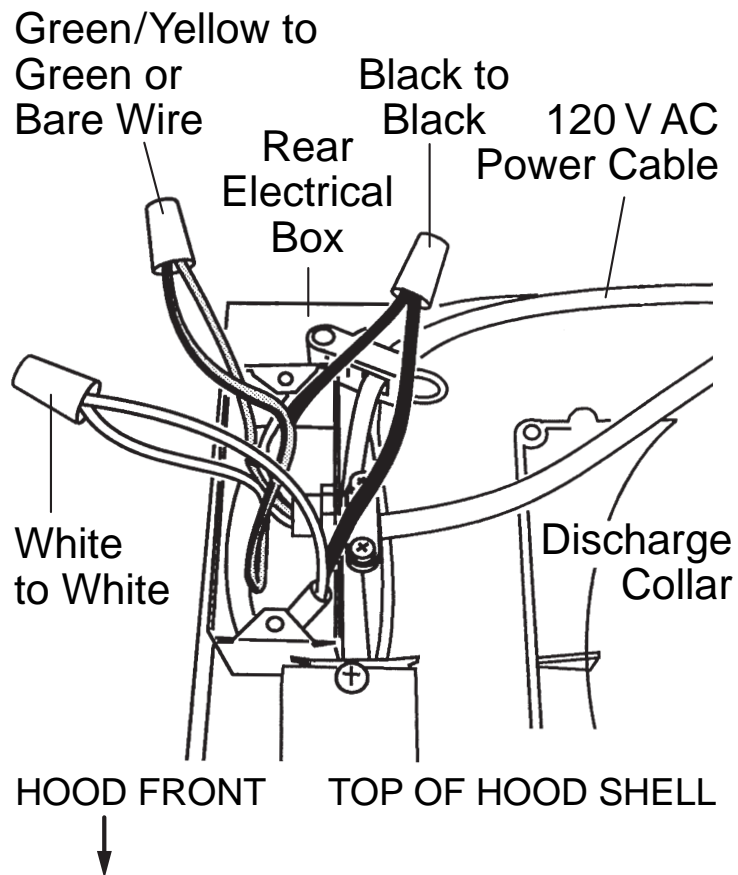
**MODEL CT HOODS POWER SUPPLY WIRING**

### BLOWER WIRING DIAGRAM & SCHEMATIC (450/600/900INT)

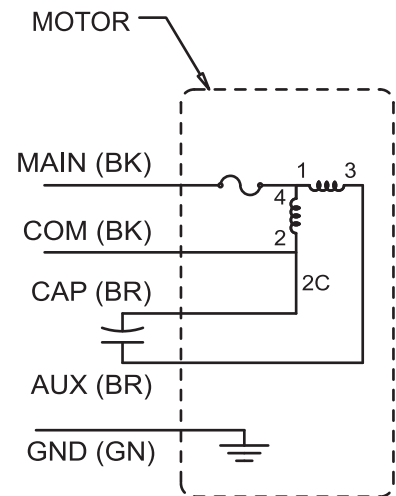
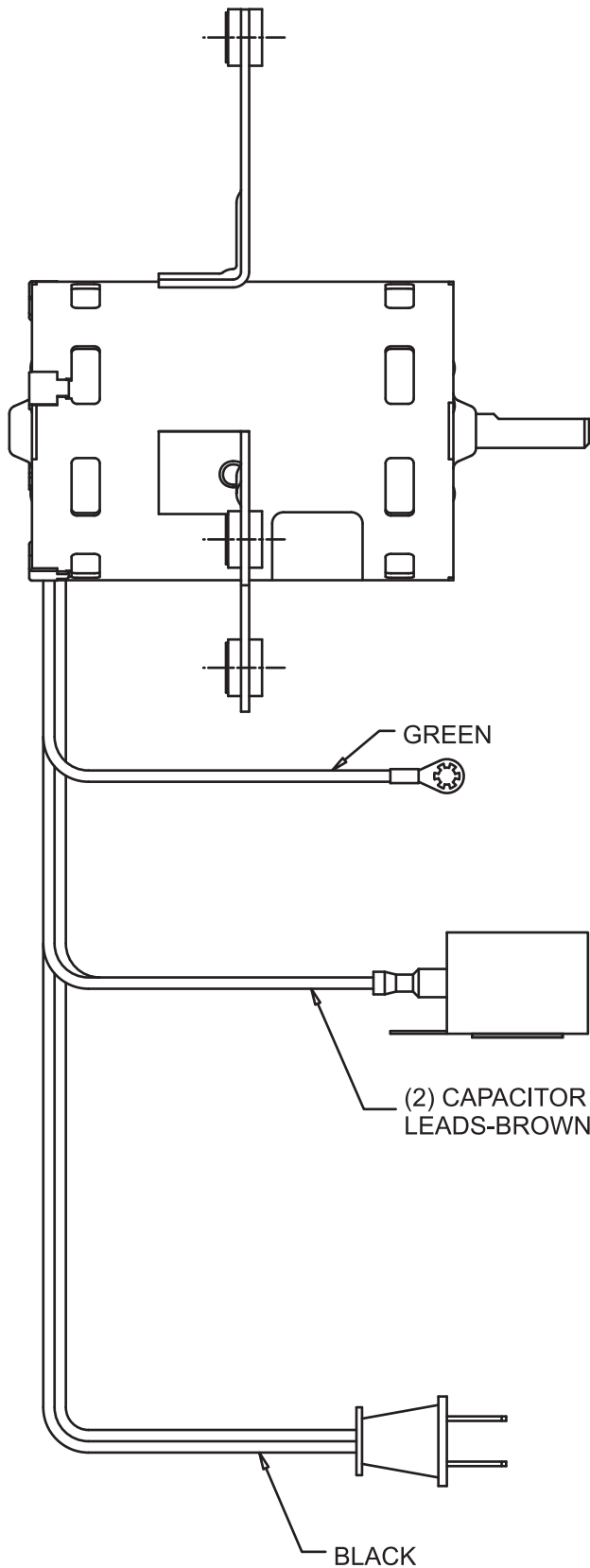

SCHEMATIC

**BLOWER SCHEMATIC (600/900EXT)**

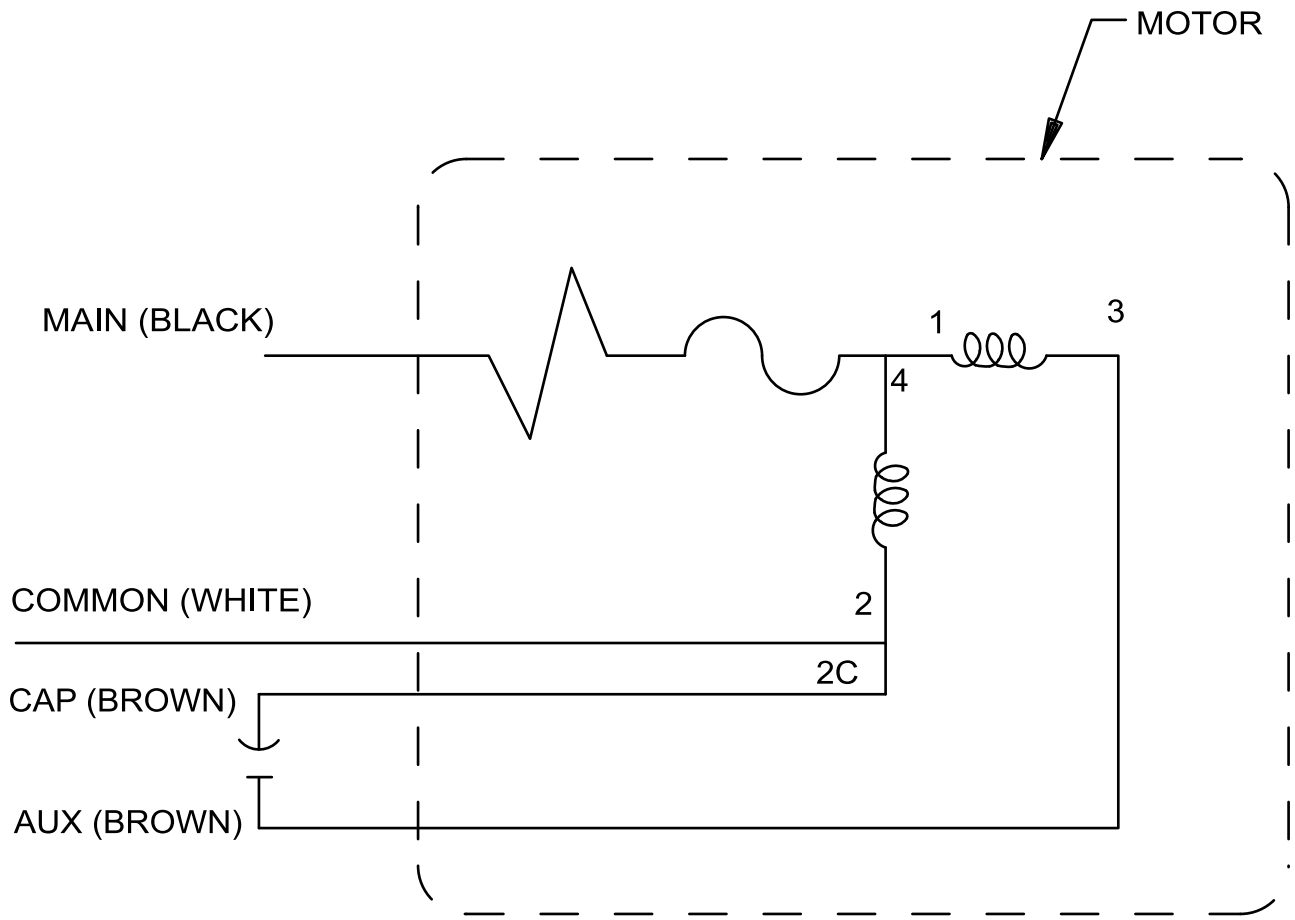

SCHEMATIC



BLOWER SCHEMATIC (1200EXT)

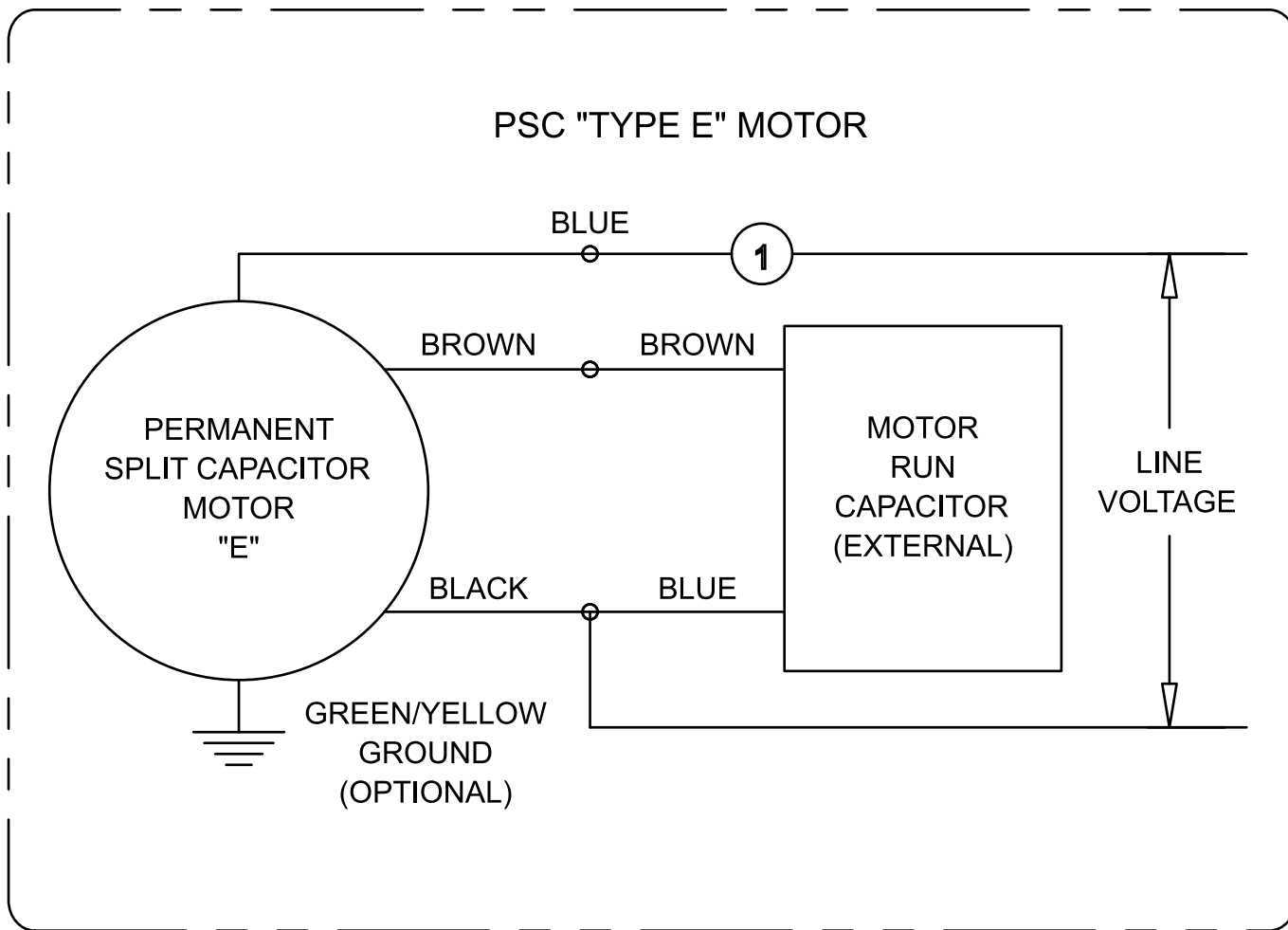

SCHEMATIC

**BLOWER SCHEMATIC (1500EXT)**

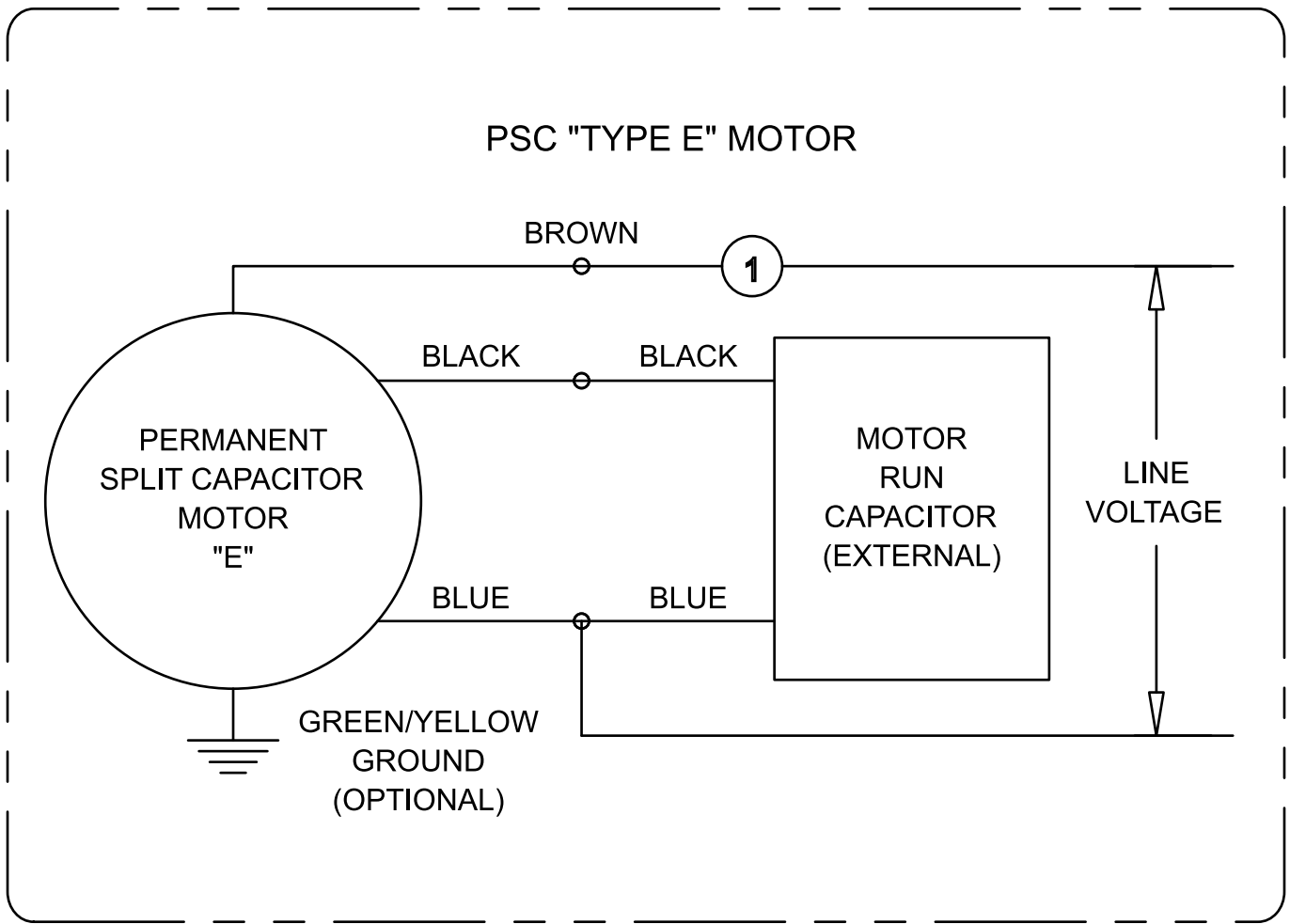

**SCHEMATIC**

SECTION 8  
PARTS LISTS &  
EXPLODED VIEWS

**MODEL CTWH30 & CTWH36 PARTS LIST**

<u>Ref #</u>	<u>Part #</u>	<u>Description</u>	<u>Ref #</u>	<u>Part #</u>	<u>Description</u>
1	803662	Damper Assembly	9	803680	Decorative Flue Bottom
2	803665	User Interface Switch Assy	10	803681	Decorative Flue Top
3	803670	Halogen Lamp Assy (incl bulb)	11	803686	Lampholder Support (CTWH30)
4	803816	Light Bulb		803697	Lampholder Support (CTWH36)
5	803672	Control Assembly	12	803687	Filter Front Support Assy (CTWH30)
6	803677	Heat Sentry		803698	Filter Front Support Assy (CTWH36)
7	803678	Grease Filter	13	803690	Transformer with Wires (CTWH30)
8	803679	Outlet		803701	Transformer with Wires (CTWH36)

NOT ILLUSTRATED

806367 Ribbon Cable Swtch - Cntrl Brd

MODEL CTWH30 & CTWH36 EXPLODED VIEW

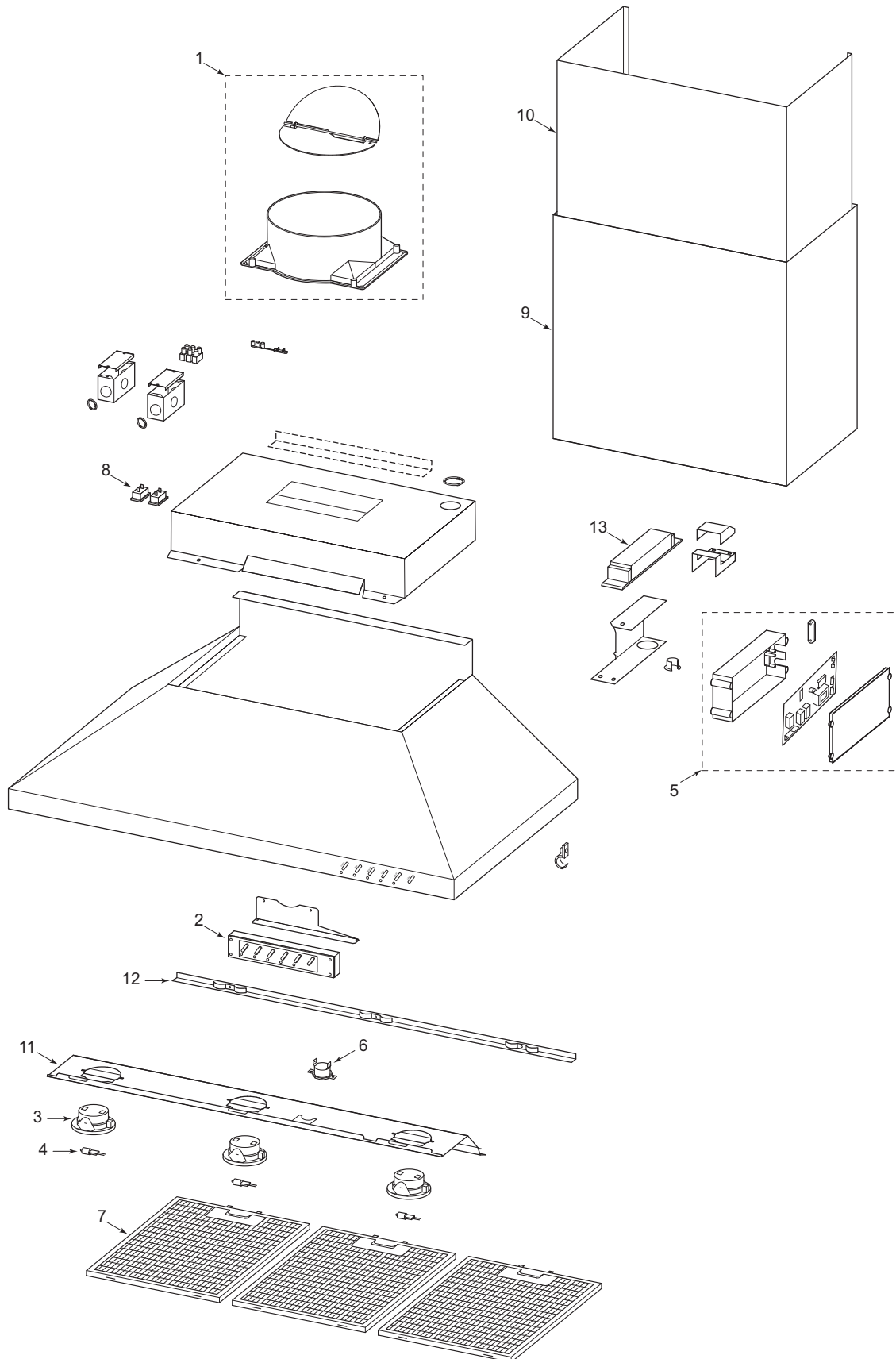

**MODEL IH4227 PARTS LIST**

<u>Ref #</u>	<u>Part #</u>	<u>Description</u>	<u>Ref #</u>	<u>Part #</u>	<u>Description</u>
1	803662	Damper Assembly	9	803704	Decorative Flue Bottom
2	803665	User Interface Switch Assy	10	803705	Decorative Flue Top
3	803670	Halogen Lamp Assy (incl bulb)	11	803712	Lampholder Support
4	803816	Light Bulb	12	803712	Lampholder Support
5	803672	Control Assembly	13	803716	Transformer with Wires (IH4227)
6	803677	Heat Sentry	14	803706	Telescopic Skeleton Bottom
7	803678	Grease Filter	15	803707	Telescopic Skeleton Top
8	803679	Outlet			

MODEL IH4227 EXPLODED VIEW

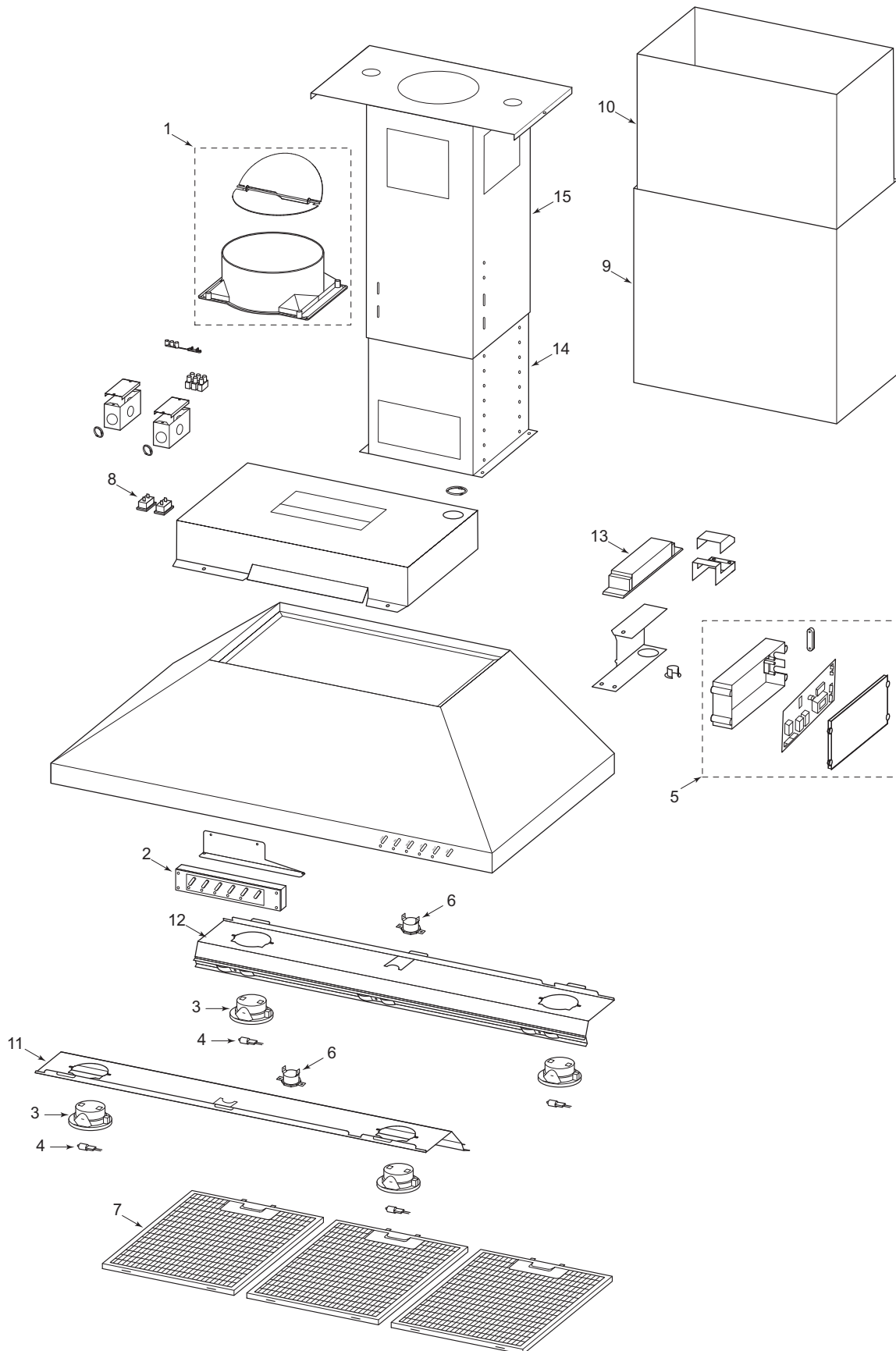

**MODEL CTEWH30I & CTEWH36I & CTEWH45I PARTS LIST**

<u>Ref #</u>	<u>Part #</u>	<u>Description</u>	<u>Ref #</u>	<u>Part #</u>	<u>Description</u>
1	813007	Grease Filter	13	812990	Feeder Cable Connection Box
2	812991	Condenser	14	812978	Bottom Flue
3	813015	Electrical Box Support	15	812977	Upper Flue
4	803671	Lamp Bulb	16	812981	Telescopic Duct Upper Bracket
5	812998	Heat Sentry	17	812988	Electrical Printed Circuit Board
6	812999	Motor (Clockwise)	18	812989	Transformer
7	812984	Blower Bracket	19	813046	Main Switch
8	813000	Bottom Bracket	20	812994	Inside Panel (30I)
9	813012	Wires		812995	Inside Panel (36I)
10	813001	Glass Front Assy (30I)		812997	Inside Panel (45I)
	813002	Glass Front Assy (36I)	21	812982	Cover
	813003	Glass Front Assy (45I)	22	812985	Blower Support Bracket
11	813045	Outlet Damper-Internal	23	812992	Halogen Lamp
12	813008	Charcoal Filter Spacer (30I)	24	813006	Hinge
	813009	Charcoal Filter Spacer (36I)			
	813011	Charcoal Filter Spacer (45I)			



MODEL CTEWH30I & CTEWH36I & CTEWH45I EXPLODED VIEW

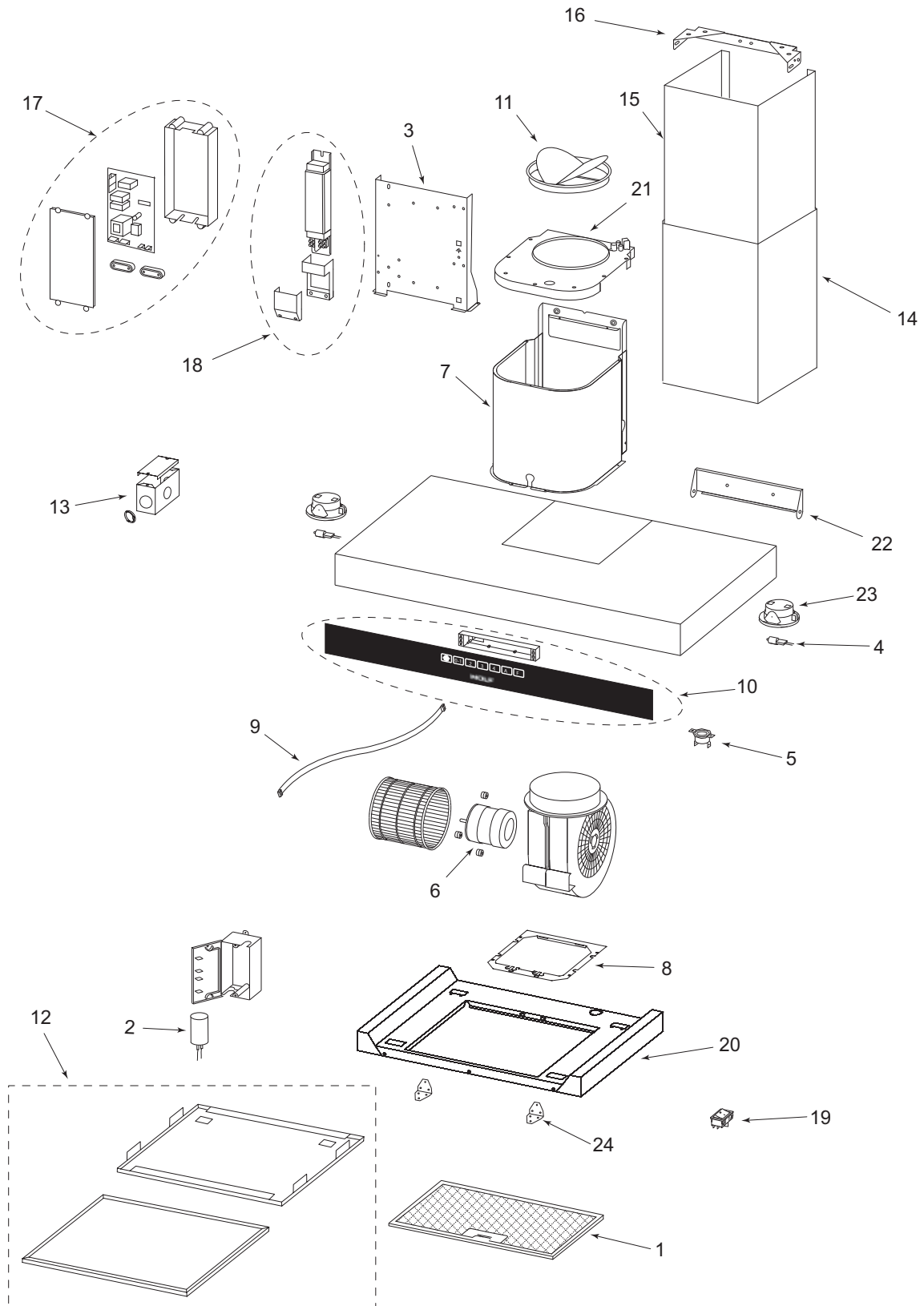

**MODEL CTEWH36 & CTEWH45 PARTS LIST**

<u>Ref #</u>	<u>Part #</u>	<u>Description</u>	<u>Ref #</u>	<u>Part #</u>	<u>Description</u>
1	813007	Grease Filter	11	812990	Feeder Cable Connection Box
2	813015	Electrical Box Support	12	812978	Bottom Flue
3	803671	Lamp Bulb	13	812977	Upper Flue
4	812998	Heat Sentry	14	812981	Telescopic Duct Upper Bracket
5	812984	Blower Bracket	15	812987	Electrical Printed Circuit Board
6	813000	Bottom Bracket	16	812989	Transformer
7	813012	Wires	17	813046	Main Switch
8	813002	Glass Front Assy (36)	18	812995	Inside Panel (36)
	813003	Glass Front Assy (45)		812997	Inside Panel (45)
9	813013	Outlet Damper External	19	812983	Cover
10	813009	Charcoal Filter Spacer (36)	20	812992	Halogen Lamp
	813011	Charcoal Filter Spacer (45)	21	813006	Hinge

MODEL CTEWH36 & CTEWH45 EXPLODED VIEW

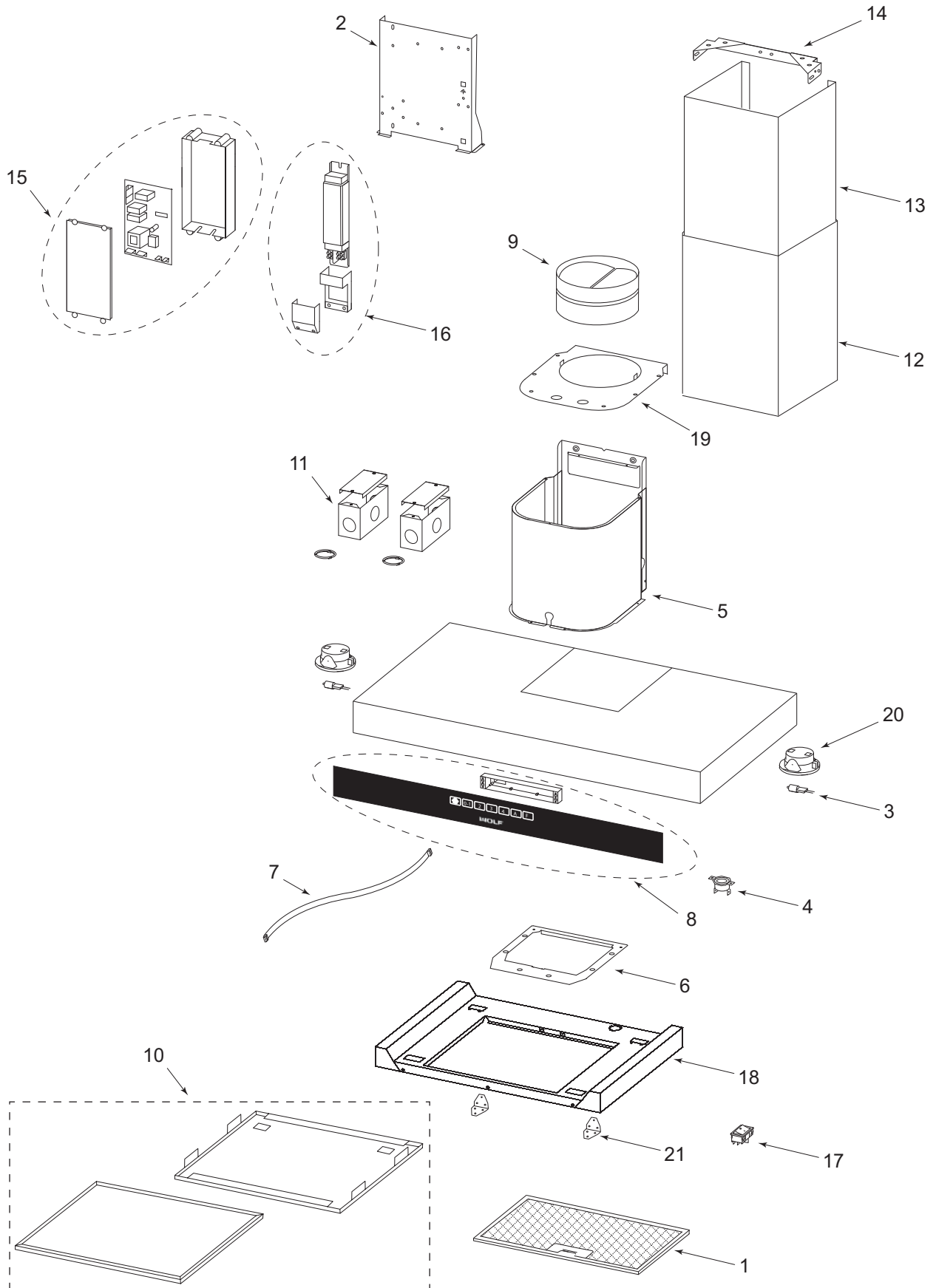

**MODEL CTEIH42I PARTS LIST**

<u>Ref #</u>	<u>Part #</u>	<u>Description</u>	<u>Ref #</u>	<u>Part #</u>	<u>Description</u>
1	813007	Grease Filter	15	812980	Bottom Flue
2	812991	Condenser	16	812979	Upper Flue
3	813019	Electrical Box Support	17	813017	Bottom Telescopic Skeleton
4	803671	Lamp Bulb	18	813018	Bottom Telescopic Skeleton
5	812998	Heat Sentry	19	812988	Electrical Printed Circuit Board
6	812999	Motor (Clockwise)	20	812989	Transformer
7	813014	Outlet Transition	21	813046	Main Switch
8	813021	Blower Bracket	22	812996	Inside Panel
9	813016	Upper Bracket	23	813020	Bracket Support
10	813000	Bottom Bracket	24	812985	Blower Support Bracket
11	813012	Wires	25	812992	Halogen Lamp
12	813004	Glass Front Assy	26	813006	Hinge
13	813010	Charcoal Filter Assy			
14	812990	Feeder Cable Connection Box			

MODEL CTEIH42I EXPLODED VIEW

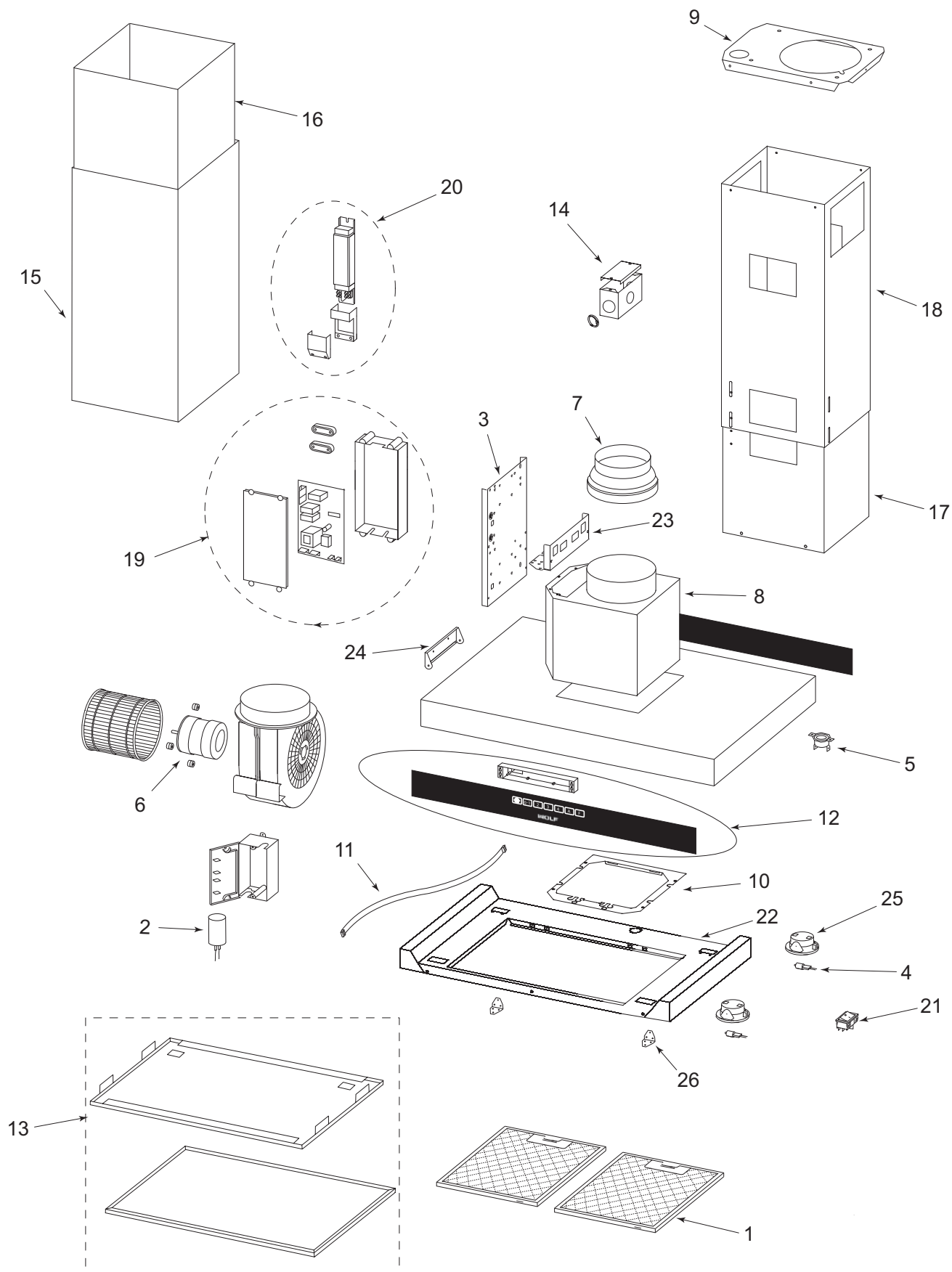

**MODEL DOWNDRAFT PARTS LIST**

Ref #	Part #	Description	Ref #	Part #	Description
1	803587	Top Cover, Stainless Steel, 30"	27	803612	Outlet Plate, Ext/Remote Blower
	803588	Top Cover, Stainless Steel, 36"	28	* NA	Plastic Clip
	806429	Top Cover, Stainless Steel, 45"	29	* NA	Screw, 10-32 X .500
	803634	Top Cover, Platinum, 30"	30	* NA	Nylon Spacer, .171 id x .375 L
	803602	Top Cover, Platinum, 36"	31	803595	Cntrl Brd, DD (See SN Break)
	803603	Top Cover, Black, 30"		805906	Cntrl Brd, DD (See SN Break) (Intl Only)
	803604	Top Cover, Black, 36"		810086	Cntrl Brd, DD (See SN Break)
	803722	Installation Template 30"		810087	Cntrl Brd, DD (See SN Break) (Intl Only)
	803723	Installation Template 36"	32	* NA	Hex Nut 8-32 KEPS
	806442	Installation Template 45"	33	* NA	Screw, 8-32 X .5 PH RD HD
2	803594	User Interface Assy, SS (See SN Break)	34	803619	Gear Motor Bracket
	810083	User Interface Assy, SS (See SN Break)		808431	Gear Motor Bracket
	803605	User Interface Assy, PI (See SN Break)	35	803626	Whiz Nut, 10-24 (Set of 8)
	810084	User Interface Assy, PI (See SN Break)	36	808432	Gear Mtr Assy w/Micro Swtchs, 30"
	803606	User Interface Assy, Blk (See SN Break)		810888	Gear Mtr Assy w/Micro Swtchs (DD36I)
	810085	User Interface Assy, Blk (See SN Break)		810889	Gear Mtr Assy w/Micro Swtchs (DD36R)
3	803593	Cable, User Interface (See SN Break)		808435	Gear Motor Kit (Model DD45I, 45R)
	810082	Cable, User Interface (See SN Break)	37	804231	Micro-Switches (Set of 2)
4	* NA	Screw HD Tap, 8-18 X .375	38	* NA	Screw, #4-40 X 1
5	803607	End Cap RH	39	803610	Wire Harness, Ext/Remote Blower
6	* NA	Pop Rivet, .125 X .212	40	803632	Gear Motor Cover (Model DD30I)
7	804790	Filter Clip, DD (Set of 4)		803622	Gear Motor Cover (Model DD30R)
8	803590	Chimney Assy., 30"		803621	Gear Motor Cover (Model DD36I)
	803635	Chimney Assy., 36"		803623	Gear Motor Cover (Model DD36R)
	806430	Chimney Assy., 45"		808436	Gear Motor Cover (Model DD36I)
9	803608	End Cap LH		808437	Gear Motor Cover (Model DD36R)
10	804520	Srv. Assy. Foam Seal, 30" (Downdraft)		806440	Gear Motor Cover (Model DD45I)
	804521	Srv. Assy. Foam Seal, 36" (Downdraft)		806441	Gear Motor Cover (Model DD45R)
	806432	Foam Seal, 45"	41	803625	Airbox Clamp (Set of 2)
11	803631	Ground Wire w/Screw	42	803624	Airbox Opening Cover
12	804791	Grille, Filter 30" RH	43	803618	Front Airbox Bottom, 30"
	804792	Grille, Filter 30" LH		803630	Front Airbox Bottom, 36"
	804793	Grille, Filter 36" RH		806439	Front Airbox Bottom, 45"
	804794	Grille, Filter 36" LH		808430	Front Airbox Assy, 36"
	806435	Grille, Filter 45" LH		806439	Front Airbox Assy, 45"
	806434	Grille, Filter 45" RH	44	803597	Blower Motor with Capacitor (500CFM)
13	804795	Filter 30"	45	803600	Isolator, Motor Mount (3 Required)
	804796	Filter 36"	46	803633	Scroll Box Assy
	806436	Filter 45"	47	803599	Capacitor
14	804797	Front Airbox Assy, 30"	48	803601	Capacitor Clamp w/screws
	805039	Front Airbox Assy, 36"	49	803627	Scroll Box cover
	806438	Front Airbox Assy, 45"	50	803598	Blower Wheel
15	803614	Slide Strips (Set of 5)	51	803628	Exterior Scroll Box Weld
16	803613	Spacer (Set of 4)		808438	SCROLL BOX WELDMENT
17	804563	Downdraft Hardware Mount Pack	52	804799	Trim Panel 30"
18	803609	Machine Chimney Slide Assy		805038	Trim Panel 36"
19	803615	Airbox Weldment, 30"		806431	Trim Panel 45"
	803616	Airbox Weldment, 36"	53	* NA	Push Nut, #10
	806437	Airbox Weldment 45"	54	805040	Top Cvr, Mount Hrdwr Pck (RH/LH Set)
20	803611	Wire Harness, Downdraft	55	803591	Filter Assemblies, 30
21	* NA	Screw, 8B - .250		803592	Filter Assemblies, 36
22	803617	Cord Set		806433	Filter Assemblies, 45
23	803596	Crank Assy			
24	* NA	Screw HD Tap, 8-18 X .375			
25	803629	Adapter Plate, Ext/Remote Blower			
26	804798	Cover, Adapter Plate			
	810890	Cover, Adapter Plate Remote Blower			

## MODEL DOWNDRAFT EXPLODED VIEW

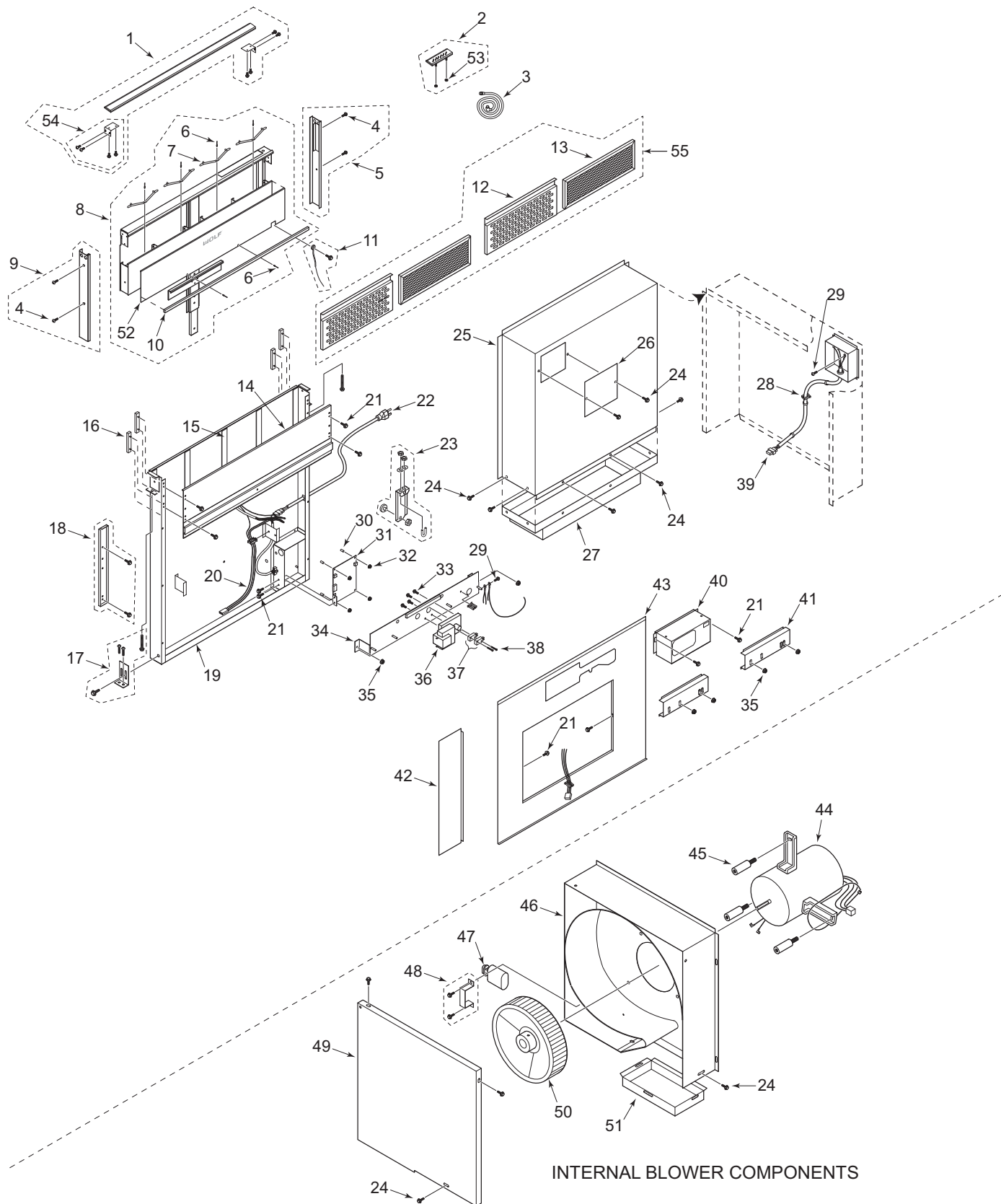

INTERNAL BLOWER COMPONENTS

**MODEL ICBDDI & ICBDDR PARTS LIST**

Ref #	Part #	Description
1	803590	Chimney Assembly 30"
	803635	Chimney Assembly 36"
	806430	Chimney Assembly 45"
2	804799	Trim Panel 30"
	805038	Trim Panel 36"
	806431	Trim Panel 45"
3	804520	Foam Seal 30"
	804521	Foam Seal 36"
	806432	Foam Seal 45"
4	804790	Filter Spring (4)
5	803591	Filter Assembly 30"
	803592	Filter Assembly 36"
	806433	Filter Assembly 45"
6	804791	Right Hand Filter Grille 30"
	804793	Right Hand Filter Grille 36"
	806434	Right Hand Filter Grille 45"
7	804792	Left Hand Filter Grille 30"
	804794	Left Hand Filter Grille 36"
	806435	Left Hand Filter Grille 45"
8	804795	Filter 30"
	804796	Filter 36"
	806436	Filter 45"
9	813898	Airbox Weldment 30"
	813899	Airbox Weldment 36"
	813900	Airbox Weldment 45"
10	804797	Airbox Front 30"
	805039	Airbox Front 36"
	806438	Airbox Front 45"
11	803614	Slide Strips
12	803613	Spacers (Set of 4)
13	814247	Lower PC Board 240V 50/60hz
14	803596	Crank Assembly
15	803607	Right Hand End Cap
16	803608	Left Hand End Cap
17	803609	Chimney Slide
18	803611	Wire Harness
19	803631	Ground Wire Assembly

Ref #	Part #	Description
20	813033	Cord Set - Intl
21	803618	Front Airbox Bottom 30"
	808430	Front Airbox Bottom 36"
	806439	Front Airbox Bottom 45"
22	810887	Gear Motor Bracket
23	813034	Gear Motor
24	813036	Gear Motor Cover ICBDD30I
	813037	Gear Motor Cover ICBDD30R
	813901	Gear Motor Cover ICBDD36I
	813902	Gear Motor Cover ICBDD36R
	813903	Gear Motor Cover ICBDD45I
	813904	Gear Motor Cover ICBDD45R
25	803625	Airbox Clamp
26	803626	Whiz Nuts (8)
27	803722	Installation Template 30"
	803723	Installation Template 36"
	806442	Installation Template 45"
28	803627	Scroll Box Cover
29	808438	Scroll Box Weldment
30	803610	Blower Wire Harness
31	803612	Outlet Plate
32	810890	Adapter Plate
33	804798	Electrical Box Cover
<u>NOT ILLUSTRATED</u>		
	813039	Blower Motor w/Capacitor
	803598	Blower Wheel
	803600	Motor Insulator
	803587	Top Cover SST 30N
	803588	Top Cover SST 36N
	806429	Top Cover SST 45N
	813207	Interface, DNDFT-Stnls
	803610	Wire Harness, Ext/Remote Blower
	810082	Cable, User Interface



MODEL ICBDDI & ICBDDR EXPLODED VIEW

