

Service

Manual for Automatic Washers

Service Manual for
Amana®

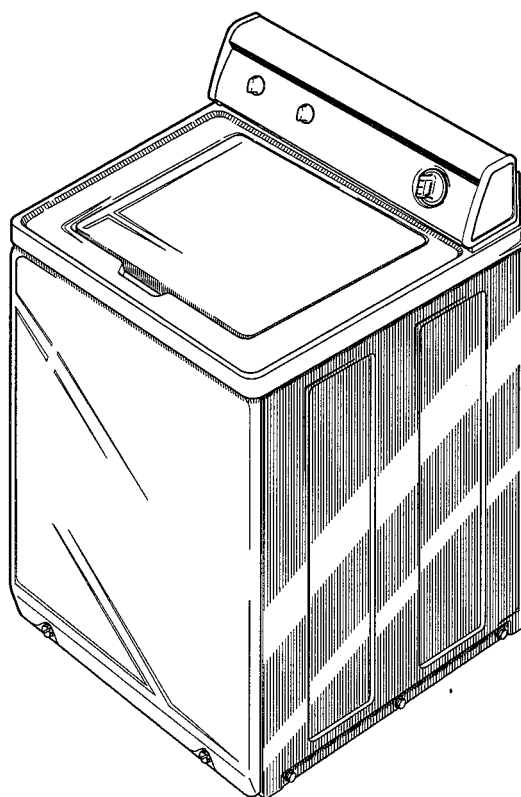

W424SE1A

Models and manufacturing
numbers in this manual

LWA05AW	PLWA05AW
LWA10AW	PLWA10AW
LWA18AW	PLWA18AW
LWA20AW	PLWA20AW
LWA30AL	PLWA30AL
LWA30AW	PLWA30AW
LWA30BL	PLWA30BL
LWA30BW	PLWA30BW
LWA40AL	PLWA40AL
LWA40AW	PLWA40AW
LWA40AL2	PLWA40AL2
LWA40AW2	PLWA40AW2
LWA50AL	PLWA50AL
LWA50AW	PLWA50AW
LWA60AL	PLWA60AL
LWA60AW	PLWA60AW
LWA80AL	PLWA80AL
LWA80AW	PLWA80AW
LWA90AL	PLWA90AL
LWA90AW	PLWA90AW
LWC05AW	PLWC05AW
LWC07AW	PLWC07AW
LWC18AW	PLWC18AW
LWC30AW	PLWC30AW
LWC40AW	PLWC40AW
LWC50AW	PLWC50AW
LWC75AW	PLWC75AW
LWC80AW	PLWC80AW
LWC90AW	PLWC90AW
LWD27AW	PLWD27AW
LWD27BW	PLWD27BW
LWD35AW	PLWD35AW
LWD37AW	PLWD37AW
LWD40AW	PLWD40AW
LWD75AW	PLWD75AW

This manual is to be used by qualified appliance technicians only. Amana does not assume any responsibility for property damage or personal injury for improper service procedures done by an unqualified person.

Amana

RS310005
Revision 3
39010
October 1998

Table of Contents

SECTION 1 — Safety Information	1-1	SECTION 5 — Service Procedures	
SECTION 2 — Introduction		1. Control Hood Assembly	5-1
Nameplate Location.....	2-1	2. Electronic Control.....	5-1
Model Identification	2-1	3. Timer.....	5-7
How Your Washer Works	2-2	4. Temperature Switch	5-9
SECTION 3 — Troubleshooting		5. Pressure Switch.....	5-9
1. No Hot Water.....	3-1	6. Graphic Panel.....	5-9
2. No Cold Water.....	3-2	7. Loading Door.....	5-10
3. No Warm Water.....	3-2	8. Agitator	5-11
4. Water Fill Does Not Stop At Proper Level	3-3	9. Agitator, Drive Bell And Seal Assembly	5-12
5. Timer Does Not Advance.....	3-3	10. Front Panel.....	5-15
6. Motor Does Not Run	3-4	11. Motor and Mounting Bracket.....	5-16
7. No Agitation.....	3-5	12. Idler Lever And Pulley.....	5-18
8. Constant Agitation.....	3-5	13. Motor Drive Pulley	5-19
9. Washer Smokes, Overheats, Cycles On Motor Thermal Protector, Switch Actuator Kicks In And Out.....	3-6	14. Motor Switch	5-22
10. Slow Spin Or No Spin.....	3-7	15. Cabinet Top Assembly	5-23
11. Constant Spin	3-8	16. Door Switch	5-25
12. Washer Stops In Cycle; Quits After A Couple Loads; Is Intermittent	3-8	17. Mixing Valve Assembly.....	5-26
13. Washer Is Locked Up Or Binding	3-8	18. Washtub And Balance Ring	5-28
14. Outer Tub Does Not Empty.....	3-9	19. Hub and Seal Kit Assembly.....	5-31
15. Excessive Vibration.....	3-9	20. Outer Tub	5-36
16. Water Leaking From Outer Tub	3-9	21. Drive Pulley, Helix And Brake	5-39
SECTION 4 — Grounding		22. Weldment And Bearing Assembly.....	5-43
1. Wall Receptacle Polarity Check.....	4-1	23. Transmission Assembly	5-45
2. Power Cord To Cabinet Top, Cabinet Top To Control Hood Mounting Bracket, Pressure Switch Mounting Bracket And Ground Tab On Graphics Panel.....	4-2	24. Upper Bearing Assembly.....	5-51
3. Control Hood Wire Harness To Top Left Rear Corner Gusset Of Cabinet	4-3	25. Friction Ring	5-52
4. Wire Harness To Motor	4-3	SECTION 6 — Adjustments	
		1. Leveling Legs.....	6-1
		2. Pressure Switch.....	6-2
		3. Belt (Agitate And Spin)	6-2
		SECTION 7 — Test Procedures.....	7-1
		SECTION 8 — Cycle Sequence Charts	8-1
		SECTION 9 — Service Procedures Unique To The Electronic Control Model Washers.....	9-1
		SECTION 10 — Internal Wiring of Washer Motor Switch.....	10-1
		SECTION 11 — Wiring Diagrams	11-1

© Copyright 1997, Raytheon Appliances

All rights reserved. No part of the contents of this book may be reproduced or transmitted in any form or by any means without the written permission of the publisher.

SECTION 1

Safety Information

Throughout this machine and on machine decals, you will find precautionary statements (“CAUTION”, “WARNING”, and “DANGER”) followed by specific instructions. These precautions are intended for the personal safety of the operator, user, servicer, and those maintaining the machine.

▲ DANGER

Danger indicates the presence of a hazard that **will** cause **severe** personal injury, death, or substantial property damage if the danger is ignored.

▲ WARNING

Warning indicates the presence of a hazard that **can** cause **severe** personal injury, death, or substantial property damage if the warning is ignored.

▲ CAUTION

Caution indicates the presence of a hazard that **will** or **can** cause **minor** personal injury or property damage if the caution is ignored.

Additional precautionary statements (“IMPORTANT” and “NOTE”) are followed by specific instructions.

IMPORTANT

The word “IMPORTANT” is used to inform the reader of specific procedures where minor machine damage will occur if the procedure is not followed.

NOTE

The word “NOTE” is used to communicate installation, operation, maintenance or servicing information that is important but not hazard related.

In the interest of safety, some general precautions relating to the operation of this machine follow.

	<h2>WARNING</h2>
<p>Failure to install, maintain, and/or operate this product according to the manufacturer’s instructions may result in conditions which can produce serious injury, death and/or property damage.</p> <p>Do not repair or replace any part of the product or attempt any servicing unless specifically recommended or published in this Service Manual and that you understand and have the skills to carry out.</p> <p>Whenever ground wires are removed during servicing, these ground wires must be reconnected to ensure that the product is properly grounded and to reduce the risk of fire, electric shock, serious injury, or death.</p>	
<small>W006</small>	

(continued)



WARNING

To reduce the risk of electric shock, fire, explosion, serious injury or death:

- Disconnect electric power to the washer before servicing.
- Never start the washer with any guards/panels removed.
- Whenever ground wires are removed during servicing, these ground wires must be reconnected to ensure that the washer is properly grounded.

W003



WARNING

Repairs that are made to your products by unqualified persons can result in hazards due to improper assembly to adjustments subjecting you, or the inexperienced person making such repairs, to the risk of serious injury, electrical shock, or death.

W007



CAUTION

If you or an unqualified person perform service on your product, you must assume the responsibility for any personal injury or property damage which may result. The manufacturer will not be responsible for any injury or property damage arising from improper service and/or service procedures.

W008

NOTE: The **WARNINGS** and **IMPORTANT INSTRUCTIONS** appearing in this manual are not meant to cover all possible conditions and situations that may occur. Common sense, caution and care must be exercised when installing, maintaining or operating the washer.

Always contact your dealer, distributor, service agent or the manufacturer about any problems or conditions you do not understand.

Locating an Authorized Servicer:

Raytheon Appliances is not responsible for personal injury or property damage resulting from improper service. Review all service information before beginning repairs.

Warranty service must be performed by an authorized technician, using authorized factory parts. If service is required after the warranty expires, Raytheon Appliances also recommends contacting an authorized technician and using authorized factory parts. Locate an authorized technician by calling 800-NATLSVC (800-628-5782).

For Assistance Within the U.S.A. Contact:

Consumer Affairs Department
Amana, Raytheon Appliances
2800 220th Trail
P O Box 8901
Amana, IA 52204-0001
(319) 622-5511 — Telephone
(319) 622-2977 — Facsimile

For Assistance Outside the U.S.A. Contact:

International Division
Amana, Raytheon Appliances
2800 220th Trail
P O Box 8901
Amana, IA 52204-0001
(319) 622-5511 — Telephone
(319) 622-8595 — Facsimile

SECTION 2

Introduction

Nameplate Location

When calling or writing about your washer, PLEASE GIVE MODEL, MANUFACTURING AND SERIAL NUMBER. Model, manufacturing and serial number is located on the nameplate.
Nameplate will be in the location shown.

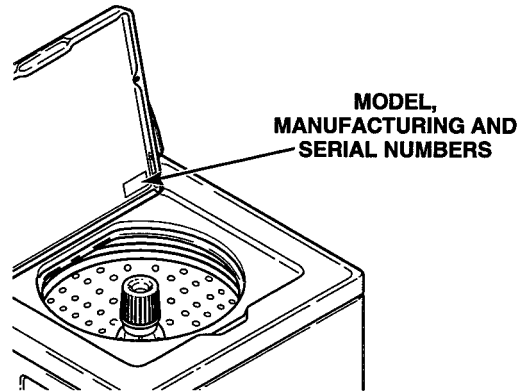

Model Identification

Information in this manual is applicable to these washer models.

Model Number	Manufacturing Number	One-Speed Motor	Two-Speed Motor	Three-Speed Motor	Timer Model	Electronic Model	Porcelain Washtub (cu. ft.)	Stainless Steel Washtub (cu. ft.)
LWA05AW	PLWA05AW		X		X		2.9	
LWA10AW	PLWA10AW	X			X			2.9
LWA18AW	PLWA18AW		X		X		3.3	
LWA20AW	PLWA20AW	X			X			3.3
LWA30AL	PLWA30AL		X		X			2.9
LWA30AW	PLWA30AW		X		X			2.9
LWA30BL	PLWA30BL		X		X			2.9
LWA30BW	PLWA30BW		X		X			2.9
LWA40AL	PLWA40AL		X		X			3.3
LWA40AW	PLWA40AW		X		X			3.3
LWA40AL2	PLWA40AL2		X		X			3.3
LWA40W2	PLWA40AW2		X		X			3.3
LWA50AL	PLWA50AL		X		X			3.3
LWA50AW	PLWA50AW		X		X			3.3
LWA60AL	PLWA60AL		X		X			3.3
LWA60AW	PLWA60AW		X		X			3.3
LWA80AL	PLWA80AL			X	X			3.3
LWA80AW	PLWA80AW			X	X			3.3
LWA90AL	PLWA90AL			X		X		3.3
LWA90AW	PLWA90AW			X		X		3.3
LWC05AW	PLWC05AW		X		X		2.9	
LWC07AW	PLWC07AW		X		X		2.9	
LWC18AW	PLWC18AW		X		X		3.3	
LWC30AW	PLWC30AW		X		X			2.9
LWC40AW	PLWC40AW		X		X			3.3
LWC50AW	PLWC50AW		X		X			3.3
LWC75AW	PLWC75AW			X	X		3.3	
LWC80AW	PLWC80AW			X	X			3.3
LWC90AW	PLWC90AW			X		X		3.3
LWD27AW	PLWD27AW		X		X			2.9
LWD27BW	PLWD27BW		X		X			2.9
LWD35AW	PLWD35AW		X		X			3.3
LWD37AW	PLWD37AW		X		X			3.3
LWD40AW	PLWD40AW		X		X			3.3
LWD75AW	PLWD75AW			X	X			3.3

How Your Washer Works

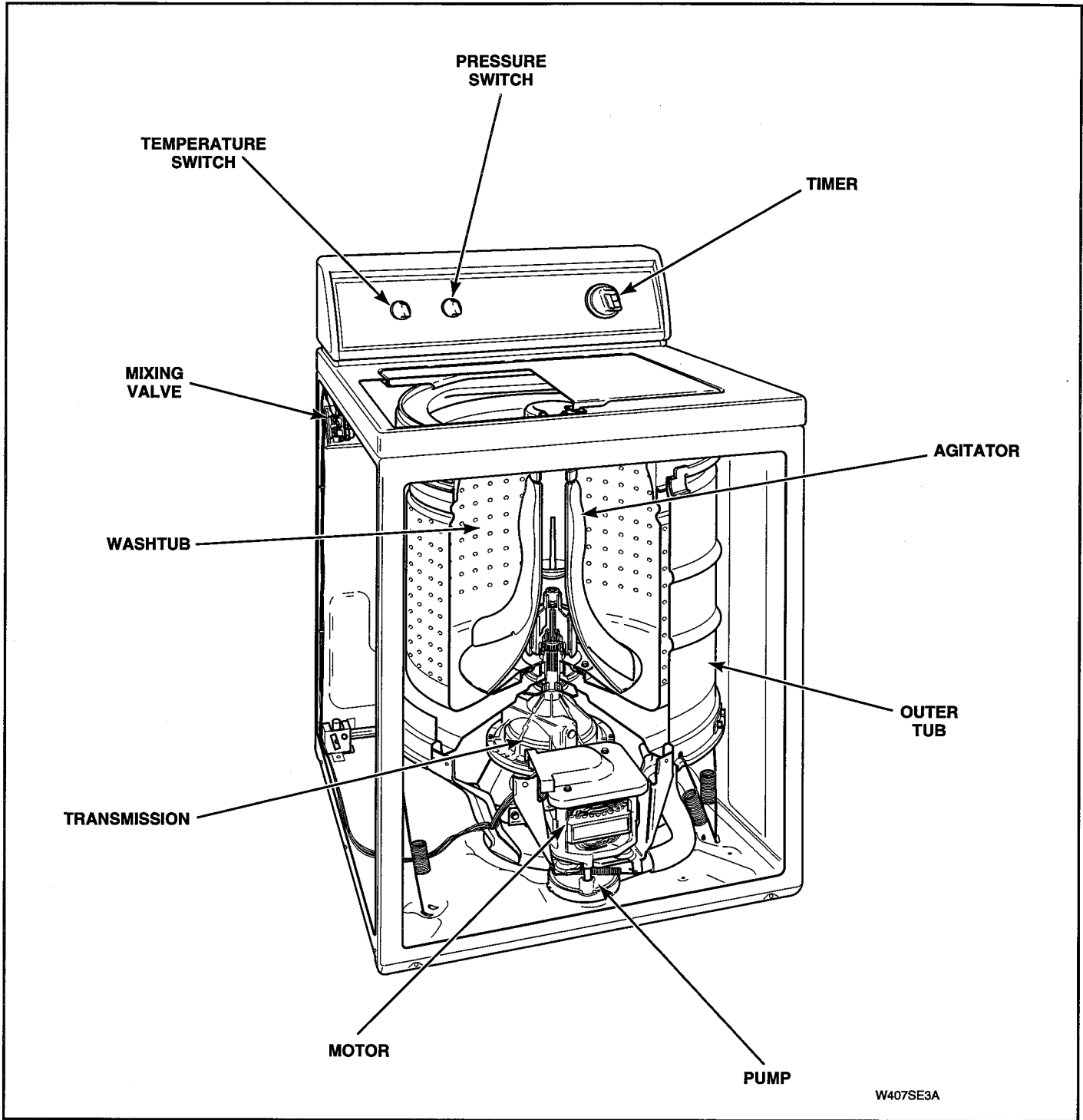

The cycle begins with a wash fill. The water temperature is determined by the temperature selector. While water fills the washtub, a column of air is trapped in a pressure bulb and hose. The air pressure continues to increase as the washtub fills with water until it is great enough to activate the pressure switch. The pressure switch then causes the wash fill to stop and wash agitation to begin. However, the loading door must be closed for the washer to agitate or spin.

The washer uses a reversing type motor, a special drive belt and an idler assembly. The idler assembly applies tension to the outside of the drive belt.

During agitation, the motor runs in the counterclockwise direction. The spring tension on the idler pulley applies the tension required to reduce the slack on the drive belt and maintain maximum belt to motor pulley contact. This eliminates belt slippage and ensures an efficient wash action, even with extra large loads.

The belt drives the transmission drive pulley in the counterclockwise direction. The pulley drives the helix which is splined to the input shaft of the transmission. This causes the input shaft to turn inside of a roller clutch which is pressed into the transmission cover. This roller clutch acts as a bearing in the counterclockwise direction allowing the transmission gears to operate. The transmission's rack and pinion gear design produces a 210 degree agitation stroke at the output shaft of the transmission which drives the agitator. The brake assembly remains locked during the agitation mode since no pressure is applied to it by the transmission drive pulley.

After the wash agitation is completed, the timer advances into the first spin. During spin, the motor reverses turning in the clockwise direction to spin the water out of the washtub. The combination of water, washtub and load weight cause the drive belt tension on the idler side of the belt to overtake the idler spring pressure allowing the belt to become slack on the opposite side. This reduces the belt to pulley contact and allows slipping between the belt and pulley.

As water is removed by the direct drive pump and the momentum of the washtub increases, the idler spring tension gradually overcomes the belt tension removing the belt slack. This eventually increases the belt to pulley contact until maximum spin speed is achieved.

The drive pulley turns clockwise riding up the ramps of the helix, exerting pressure on the brake and forcing it to release from brake pads. The helix drives the input shaft of the transmission, and when the input shaft turns in the clockwise direction the roller clutch locks onto the shaft causing the entire transmission assembly to turn. None of the gears in the transmission are operating at this time. The hub of the washtub is splined to the transmission tube and rotates with the transmission assembly. The centrifugal force created by the spinning washtub causes water to be extracted from the clothes.

Water is introduced during the first spin to "SPRAY" the garments and remove suds from them. The initial spin is followed by rinse agitation to rinse away any detergent residue. The washer fills and then agitates like the wash portion of the cycle. Following rinse agitation, a final spin extracts the rinse water from the clothes preparing them for the dryer.

SECTION 3

Troubleshooting



WARNING

To reduce the risk of electric shock, fire, explosion, serious injury or death:

- Disconnect electric power to the washer before servicing.
- Never start the washer with any guards/panels removed.
- Whenever ground wires are removed during servicing, these ground wires must be reconnected to ensure that the washer is properly grounded.

W003

IMPORTANT: Refer to appropriate Wiring Diagram for aid in testing washer components.

1. NO HOT WATER

POSSIBLE CAUSE	TO CORRECT
Hot water supply faucet is closed.	Open faucet.
Water supply is cold.	Check water heater.
Kinked hot water inlet hose.	Straighten or replace hose.
Clogged mixing valve screen, or clogged screen in outer end of inlet hose nearest water supply faucet.	Disconnect hot water inlet hose, and clean or replace screen.
Inoperative hot water mixing valve solenoid.	Test solenoid and replace if inoperative.
*Inoperative timer.	Test timer and replace if inoperative.
*Inoperative temperature switch.	Test switch and replace if inoperative.
Inoperative pressure switch.	Test switch and replace if inoperative.
Clogged pressure hose.	Remove and clean or replace hose.
Broken, loose, or incorrect wiring.	Refer to appropriate wiring diagram.
†Inoperative electronic control.	Refer to SECTION 9 to check out electronic control operation.

*Mechanical Timer Models only.

†Electronic Control Models only.



WARNING

To reduce the risk of electric shock, fire, explosion, serious injury or death:

- Disconnect electric power to the washer before servicing.
- Never start the washer with any guards/panels removed.
- Whenever ground wires are removed during servicing, these ground wires must be reconnected to ensure that the washer is properly grounded.

W003

2. NO COLD WATER

POSSIBLE CAUSE	TO CORRECT
Cold water supply faucet is closed.	Open faucet.
Kinked cold water inlet hose.	Straighten or replace hose.
Clogged mixing valve screen, or clogged screen in outer end of inlet hose nearest water supply faucet.	Disconnect cold water inlet hose, and clean or replace screen.
Inoperative cold water mixing valve solenoid.	Test solenoid and replace if inoperative.
*Inoperative timer.	Test timer and replace if inoperative.
*Inoperative temperature switch.	Test switch and replace if inoperative.
Inoperative pressure switch.	Test switch and replace if inoperative.
Clogged pressure hose.	Remove and clean or replace hose.
Broken, loose, or incorrect wiring.	Refer to appropriate wiring diagram.
†Inoperative electronic control.	Refer to SECTION 9 to check out electronic control operation.

3. NO WARM WATER

POSSIBLE CAUSE	TO CORRECT
No hot water.	Refer to paragraph 1.
No cold water.	Refer to paragraph 2.

*Mechanical Timer Models only.

†Electronic Control Models only.



WARNING

To reduce the risk of electric shock, fire, explosion, serious injury or death:

- Disconnect electric power to the washer before servicing.
- Never start the washer with any guards/panels removed.
- Whenever ground wires are removed during servicing, these ground wires must be reconnected to ensure that the washer is properly grounded.

W003

4. WATER FILL DOES NOT STOP AT PROPER LEVEL

POSSIBLE CAUSE	TO CORRECT
*Inoperative pressure switch.	Test switch and replace if inoperative.
Air leak in pressure hose.	Replace hose.
Sediment on or under mixing valve diaphragm, defective diaphragm, or armature binding in armature guide.	Replace valve.
Broken, weak, or missing mixing valve armature spring.	Replace valve.
A siphoning action started in washer will cause water to be siphoned from washer during cycle due to end of drain hose being lower than cabinet top of washer. Drain hose fits tight in standpipe or drain.	Install No. 562P3 Siphon Break Kit. Provide an air gap around drain hose and drain receptacle. Install No. 36878 Standpipe Adapter.
Water in pressure hose.	Blow air through hose to remove water or replace hose.
Broken, loose, shorted, or incorrect wiring.	Refer to inappropriate wiring diagram.
†Inoperative electronic control.	Refer to SECTION 9 to check out electronic control operation.

5. TIMER DOES NOT ADVANCE

POSSIBLE CAUSE	TO CORRECT
Timer is designed to pause during fill periods. Some cycles have pauses (delicate cycle).	Allow completion of fill period.
*Inoperative timer.	Test timer, and replace if inoperative.
Loading door is open.	Close loading door. Loading door MUST be closed any time the washer is set to agitate or spin.
Washer will not fill.	Timer pauses until pressure switch is satisfied. Refer to paragraphs 1 and 2.
Timer motor lead wire off timer terminal.	Refer to appropriate wiring diagram and reattach wire.
Broken, loose or incorrect wiring.	Refer to appropriate wiring diagram.
Make sure washer isn't siphoning during rinse fill.	Install siphon break kit, Part No. 562P3.

*Mechanical Timer Models only.

†Electronic Control Models only.



WARNING

To reduce the risk of electric shock, fire, explosion, serious injury or death:

- Disconnect electric power to the washer before servicing.
- Never start the washer with any guards/panels removed.
- Whenever ground wires are removed during servicing, these ground wires must be reconnected to ensure that the washer is properly grounded.

W003

6. MOTOR DOES NOT RUN

POSSIBLE CAUSE	TO CORRECT
Electrical power off, fuse blown, or power cord not plugged in.	Check laundry room for blown or loose fuse(s) or open circuit breakers. (Washer itself does not have an electrical fuse).
Loading door not closed or inoperative switch.	Close door or test switch and replace if inoperative.
*Timer improperly set.	Reset timer, or try another cycle.
*Inoperative timer.	Test timer and replace if inoperative.
Motor starting functions inoperative. No start; or motor hums only.	Refer to SECTION 7 to check start switch and start windings.
Motor is dead, won't run.	Refer to SECTION 7 to check switch and windings.
Motor overload protector has cycled.	Wait two or three minutes for overload protector to reset. If protector cycles repeatedly, refer to paragraph 9.
Bind in upper or lower motor bearing.	Remove belts and determine if motor shaft will spin. Replace motor if shaft is locked up.
Broken, loose, or incorrect wiring.	Refer to appropriate wiring diagram.
Power cord is miswired.	Refer to appropriate wiring diagram for correct wiring.
†Inoperative electronic control.	Refer to SECTION 9 to check out electronic control operation.

*Mechanical Timer Models only.

†Electronic Control Models only.



WARNING

To reduce the risk of electric shock, fire, explosion, serious injury or death:

- Disconnect electric power to the washer before servicing.
- Never start the washer with any guards/panels removed.
- Whenever ground wires are removed during servicing, these ground wires must be reconnected to ensure that the washer is properly grounded.

W003

7. NO AGITATION

POSSIBLE CAUSE	TO CORRECT
*Inoperative timer. Timer is designed to pause (SOAK) during DELICATE cycle.	Test timer and replace if inoperative.
Motor will not run.	Refer to SECTION 7 to check switch and windings.
No Delicate cycle agitate.	Refer to SECTION 7 to check low speed switch and windings.
*Inoperative pressure switch.	Test switch and replace if inoperative.
Broken, loose, or incorrect wiring.	Refer to appropriate wiring diagram.
Loose or broken drive belt.	Adjust or replace belt.
Inoperative transmission assembly.	Repair or replace transmission assembly.
Sheared motor pulley roll pin.	Remove drive motor and replace roll pin and any other damaged parts.
Motor overload protector has cycled.	Wait two or three minutes for overload protector to reset. If protector cycles repeatedly, refer to paragraph 9.
Bind in pump.	Replace pump.
Loading door is open or door switch is inoperative.	Close door or test switch and replace if inoperative.
†Inoperative electronic control.	Refer to SECTION 9 to check out electronic control operation.

8. CONSTANT AGITATION

POSSIBLE CAUSE	TO CORRECT
*Inoperative timer.	Test timer and replace if inoperative.
Shorted or incorrect wiring.	Refer to appropriate wiring diagram.
†Inoperative electronic control.	Refer to SECTION 9 to check out electronic control operation.

*Mechanical Timer Models only.

†Electronic Control Models only.



WARNING

To reduce the risk of electric shock, fire, explosion, serious injury or death:

- Disconnect electric power to the washer before servicing.
- Never start the washer with any guards/panels removed.
- Whenever ground wires are removed during servicing, these ground wires must be reconnected to ensure that the washer is properly grounded.

W003

9. WASHER SMOKES, OVERHEATS, CYCLES ON MOTOR THERMAL PROTECTOR, SWITCH ACTUATOR KICKS IN AND OUT

POSSIBLE CAUSE	TO CORRECT
Belt is tacky and does not allow proper slip.	Check belt and replace if defective.
Belt tension is too great and does not allow proper slip.	Make sure idler spring is properly connected.
*Inoperative timer.	Test timer and replace if inoperative.
Motor switch functions inoperative.	Refer to SECTION 7 to check switch functions.
Bind in water pump.	Replace pump.
Brake pads binding.	Free binding pads, or replace pads.
Brake, transmission, or motor have locked up and will not turn.	Check that all these components are able to move freely. Correct binding component.
Incorrect voltage.	Contact local utility company, or have a qualified electrician check power supply.

*Mechanical Timer Models only.

†Electronic Control Models only.



WARNING

To reduce the risk of electric shock, fire, explosion, serious injury or death:

- Disconnect electric power to the washer before servicing.
- Never start the washer with any guards/panels removed.
- Whenever ground wires are removed during servicing, these ground wires must be reconnected to ensure that the washer is properly grounded.

W003

10. SLOW SPIN OR NO SPIN

POSSIBLE CAUSE	TO CORRECT
*Inoperative timer.	Test timer and replace if inoperative.
Some model washers, timer is programmed for SLOW spin in DELICATE CYCLE regardless of action switch setting.	Use a different cycle.
Loading door is open or door safety switch is inoperative.	Close loading door, or test switch and replace if inoperative.
Bind in water pump.	Replace pump.
Loose or broken drive belt.	Replace belt.
Motor will not run.	Refer to MOTOR TEST SECTION 7 to check switch and windings.
Sheared motor pulley roll pin.	Remove drive motor and appropriately replace roll pin and any other damaged parts.
Motor overload protector has cycled.	Wait two or three minutes for overload protector to reset. If protector cycles repeatedly, refer to paragraph 9.
No clearance or stuck brake pads.	Free sticky brake pads or replace pads.
Broken, loose, or incorrect wiring.	Refer to appropriate wiring diagram.
Inoperative transmission assembly.	Repair or replace the transmission assembly.
†Inoperative electronic control.	Refer to SECTION 9 to check out electronic control operation.
Oil on belt.	Replace belt.

*Mechanical Timer Models only.

†Electronic Control Models only.



WARNING

To reduce the risk of electric shock, fire, explosion, serious injury or death:

- Disconnect electric power to the washer before servicing.
- Never start the washer with any guards/panels removed.
- Whenever ground wires are removed during servicing, these ground wires must be reconnected to ensure that the washer is properly grounded.

W003

11. CONSTANT SPIN

POSSIBLE CAUSE	TO CORRECT
*Inoperative timer.	Test timer and replace if inoperative.
Wash tub does not stop spinning within seven seconds after loading door is opened.	Replace brake pads.
Excessive wear on brake pads, or missing brake pads.	Replace brake pads.
Shorted or incorrect wiring.	Refer to appropriate wiring diagram.
†Inoperative electronic control.	Refer to SECTION 9 to check out electronic control operation.

12. WASHER STOPS IN CYCLE; QUILTS AFTER A COUPLE LOADS; IS INTERMITTENT

POSSIBLE CAUSE	TO CORRECT
Belt is tacky and does not allow proper slip.	Check belt and replace if defective.
Belt tension is too great and does not allow proper slip.	Make sure helper spring (if present) and idler spring are properly connected.
*Inoperative timer.	Test timer and replace if inoperative.
Broken, loose, or incorrect wiring.	Refer to appropriate wiring diagram.
Motor overload protector has cycled.	Wait two or three minutes for overload protector to reset. If protector cycles repeatedly, refer to paragraph 9.
Motor switch functions inoperative.	Refer to SECTION 7 to check switch functions.
Brake, transmission, or motor have locked up and will not turn.	Check that all these components are able to move freely.

13. WASHER IS LOCKED UP OR BINDING

POSSIBLE CAUSE	TO CORRECT
Excessive belt tension.	Replace belt and/or idler spring.
Bind in upper or lower bearing.	Replace bearing.
Bind in water pump.	Replace pump.
Bind in transmission.	Repair or replace transmission.
Brake pads binding.	Free binding pads, or replace pads.
Incorrect voltage.	Contact local utility company, or have a qualified electrician check power supply.

*Mechanical Timer Models only.

†Electronic Control Models only.



WARNING

To reduce the risk of electric shock, fire, explosion, serious injury or death:

- Disconnect electric power to the washer before servicing.
- Never start the washer with any guards/panels removed.
- Whenever ground wires are removed during servicing, these ground wires must be reconnected to ensure that the washer is properly grounded.

W003

14. OUTER TUB DOES NOT EMPTY

POSSIBLE CAUSE	TO CORRECT
Kinked drain hose.	Straighten hose.
Drain hose out of clamp in back of cabinet.	Remove washer front panel and install drain hose into clamp.
Inoperative water pump.	Replace pump.
Obstruction in outer tub outlet hose.	Remove obstruction.

15. EXCESSIVE VIBRATION

POSSIBLE CAUSE	TO CORRECT
Washer is not properly leveled.	Adjust leveling legs.
Unbalanced load in tub.	Stop washer, redistribute load, then restart washer.
Broken, or disconnected centering spring(s).	Connect or replace centering spring(s).
Washer is installed on weak, "spongy", carpeted or built-up floor.	Relocate washer, or support floor to eliminate weak or "spongy" condition.
Incorrect or loose cabinet screws.	Replace with correct screws or tighten.
Base damaged (washer was dropped).	Replace base assembly.
Lubricant on pivot dome and/or base friction ring.	Remove lubricant or replace parts.
Partial liquid filled balance ring leaking.	Replace balance ring.

16. WATER LEAKING FROM OUTER TUB

POSSIBLE CAUSE	TO CORRECT
Leaking water seal in outer tub.	Replace hub and seal kit assembly, SECTION 5, paragraph 19.
Hole in outer tub.	Replace outer tub.
Pressure hose or accumulator leaking.	Replace pressure hose and/or accumulator.
Outer tub cover gasket leaking.	Replace gasket.
Obstruction in drain causing water to come over top of outer drain tub cover.	Remove obstruction.
Tub-to-pump hose leaking at clamp.	Tighten clamp.

*Mechanical Timer Models only.

†Electronic Control Models only.

SECTION 4

Grounding



WARNING

To reduce the risk of electric shock, fire, explosion, serious injury or death:

- Disconnect electric power to the washer before servicing.
- Never start the washer with any guards/panels removed.
- Whenever ground wires are removed during servicing, these ground wires must be reconnected to ensure that the washer is properly grounded.

W003

1. WALL RECEPTACLE POLARITY CHECK. See Figure 4-1.

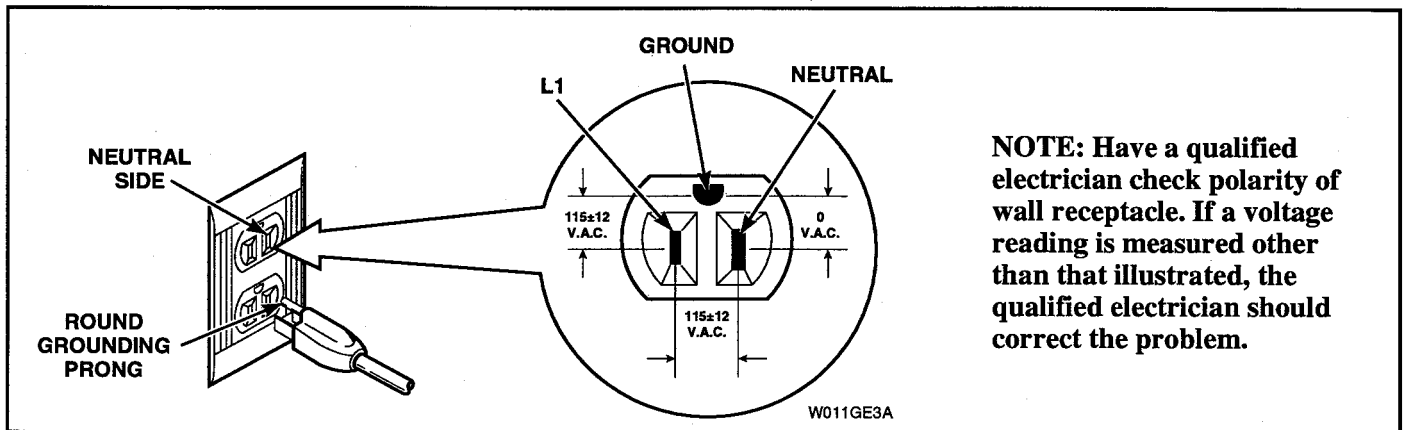

Figure 4-1



WARNING

To reduce the risk of electric shock, fire, explosion, serious injury or death:

- Disconnect electric power to the washer before servicing.
- Never start the washer with any guards/panels removed.
- Whenever ground wires are removed during servicing, these ground wires must be reconnected to ensure that the washer is properly grounded.

W008

2. POWER CORD TO CABINET TOP, CABINET TOP TO CONTROL HOOD MOUNTING BRACKET, PRESSURE SWITCH MOUNTING BRACKET AND GROUND TAB ON GRAPHICS PANEL.

See Figure 4-2.

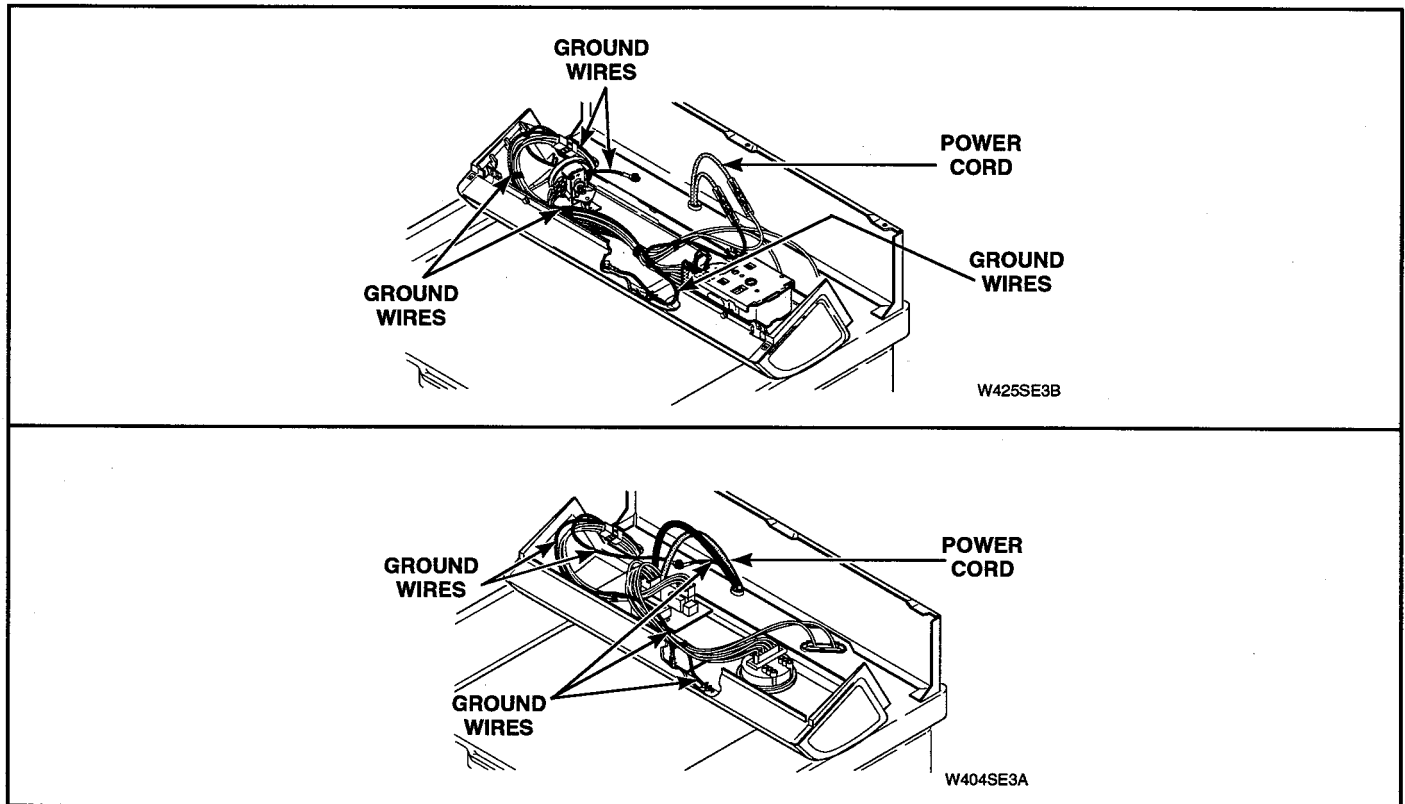

Figure 4-2



WARNING

To reduce the risk of electric shock, fire, explosion, serious injury or death:

- Disconnect electric power to the washer before servicing.
- Never start the washer with any guards/panels removed.
- Whenever ground wires are removed during servicing, these ground wires must be reconnected to ensure that the washer is properly grounded.

W003

3. CONTROL HOOD WIRE HARNESS TO TOP LEFT REAR CORNER GUSSET OF CABINET.

See Figure 4-3.

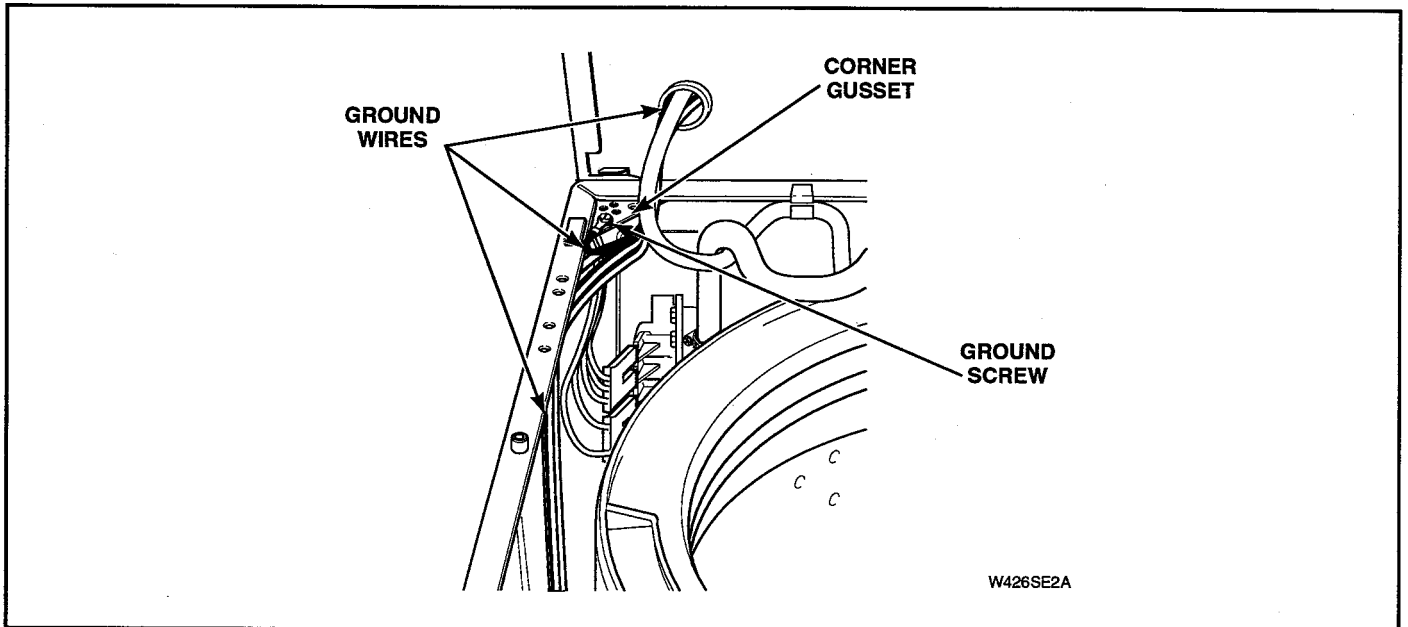

Figure 4-3

4. WIRE HARNESS TO MOTOR. See Figure 4-4.

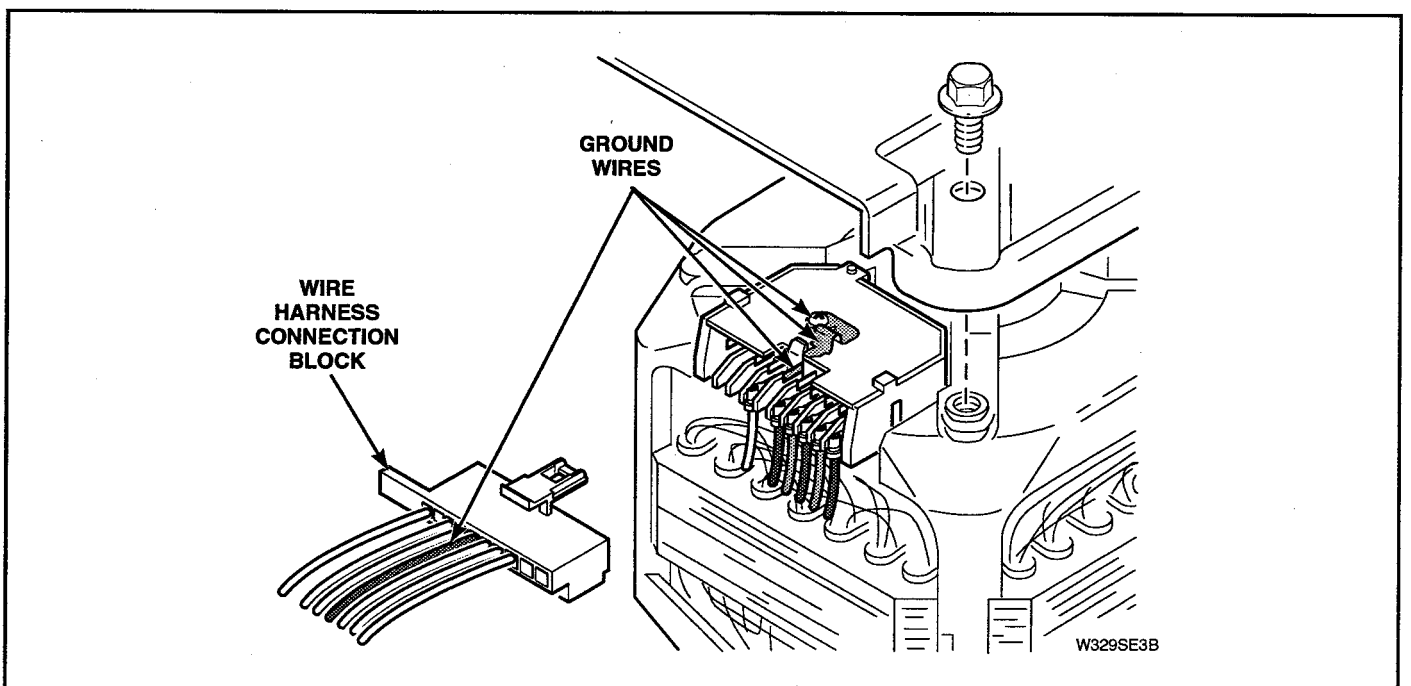

Figure 4-4

SECTION 5

Service Procedures



WARNING

To reduce the risk of electric shock, fire, explosion, serious injury or death:

- Disconnect electric power to the washer before servicing.
- Never start the washer with any guards/panels removed.
- Whenever ground wires are removed during servicing, these ground wires must be reconnected to ensure that the washer is properly grounded.

W003

IMPORTANT: When reference is made to directions (right or left) in this manual, it is from operator's position facing front of washer.

1. CONTROL HOOD ASSEMBLY

(See Figures 5-1, 5-2, 5-3, 5-4, 5-5, and 5-6)

- Remove three screws holding rear of hood assembly to control hood rear panel. See Figure 5-1.
- Pivot hood assembly forward on cabinet top.
- Carefully remove bottom front of hood from clips on cabinet top.
- Disconnect wires from component parts and carefully remove components from hood assembly.

NOTE: Refer to appropriate wiring diagram when rewiring component parts.

TO REMOVE CONTROL HOOD END PANELS

Remove four screws holding end panels to control mounting plate.

2. ELECTRONIC CONTROL

- Remove three screws holding rear of hood assembly to control hood rear panel. See Figure 5-1.
- Pivot hood assembly forward on cabinet top. See Figure 5-1.
- Remove wires from electronic control and harness at disconnect blocks.
- Remove screws holding electronic control to backside of control mounting plate and remove control. See Figure 5-6.

NOTE: When removing or installing an electronic control, handle control by edges to prevent damage to control.

NOTE: Refer to appropriate wiring diagram when rewiring electronic control.

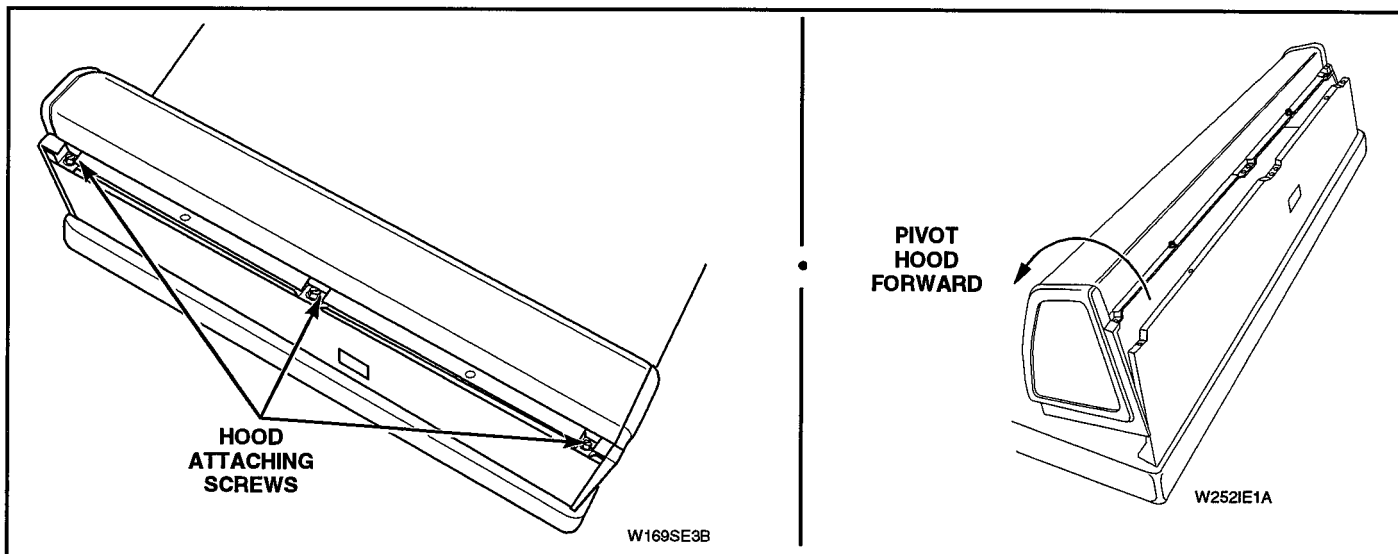

Figure 5-1

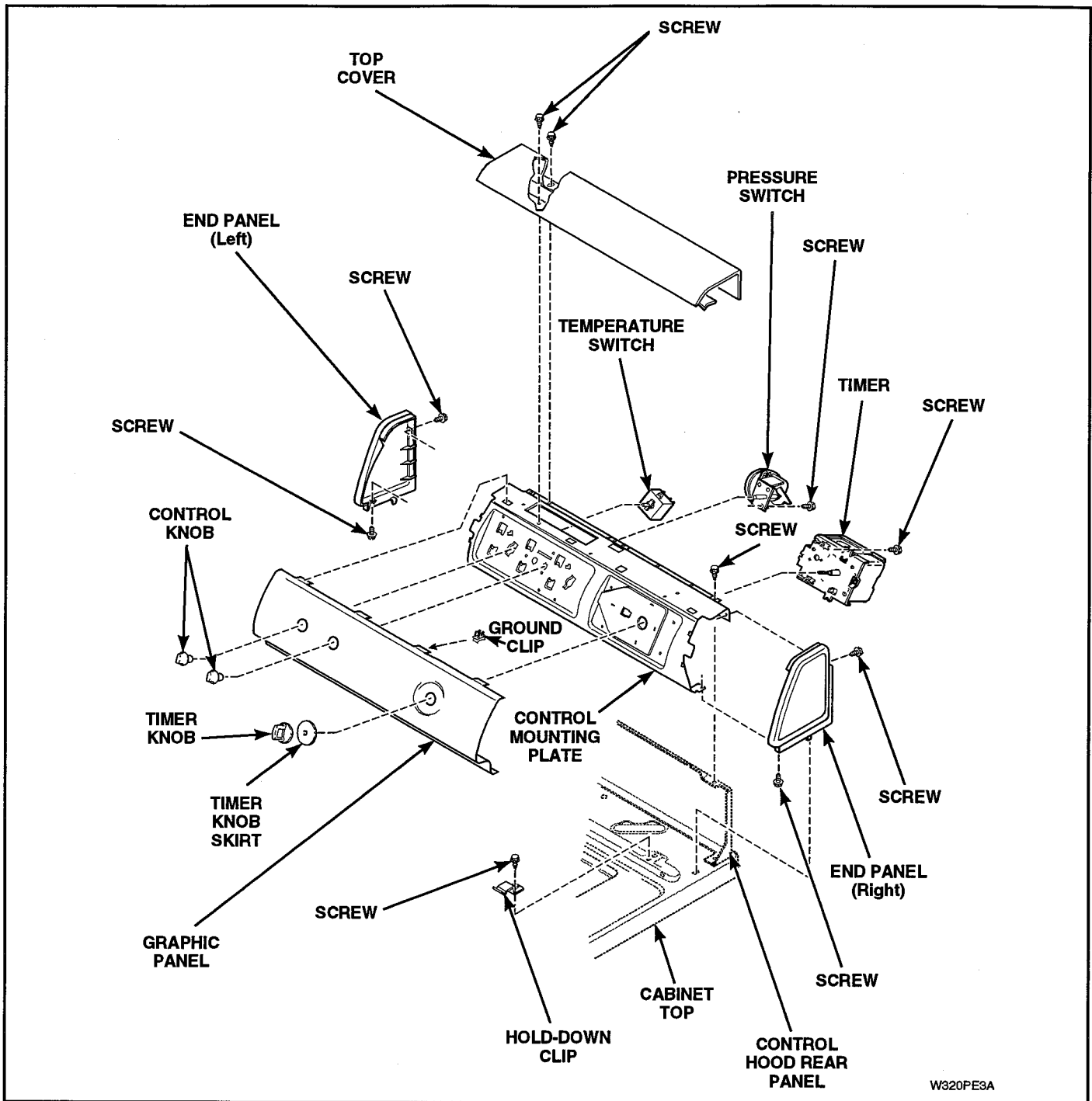

Figure 5-2

GRAPHIC PANEL, CONTROL MOUNTING PLATE AND CONTROLS

(Models LWA05A*, LWA10A*, LWA18A*, LWA30*, LWA40*, LWA03A*, LWC05A*, LWC07A*, LWC18A*, LWC30A* LWC40A*)

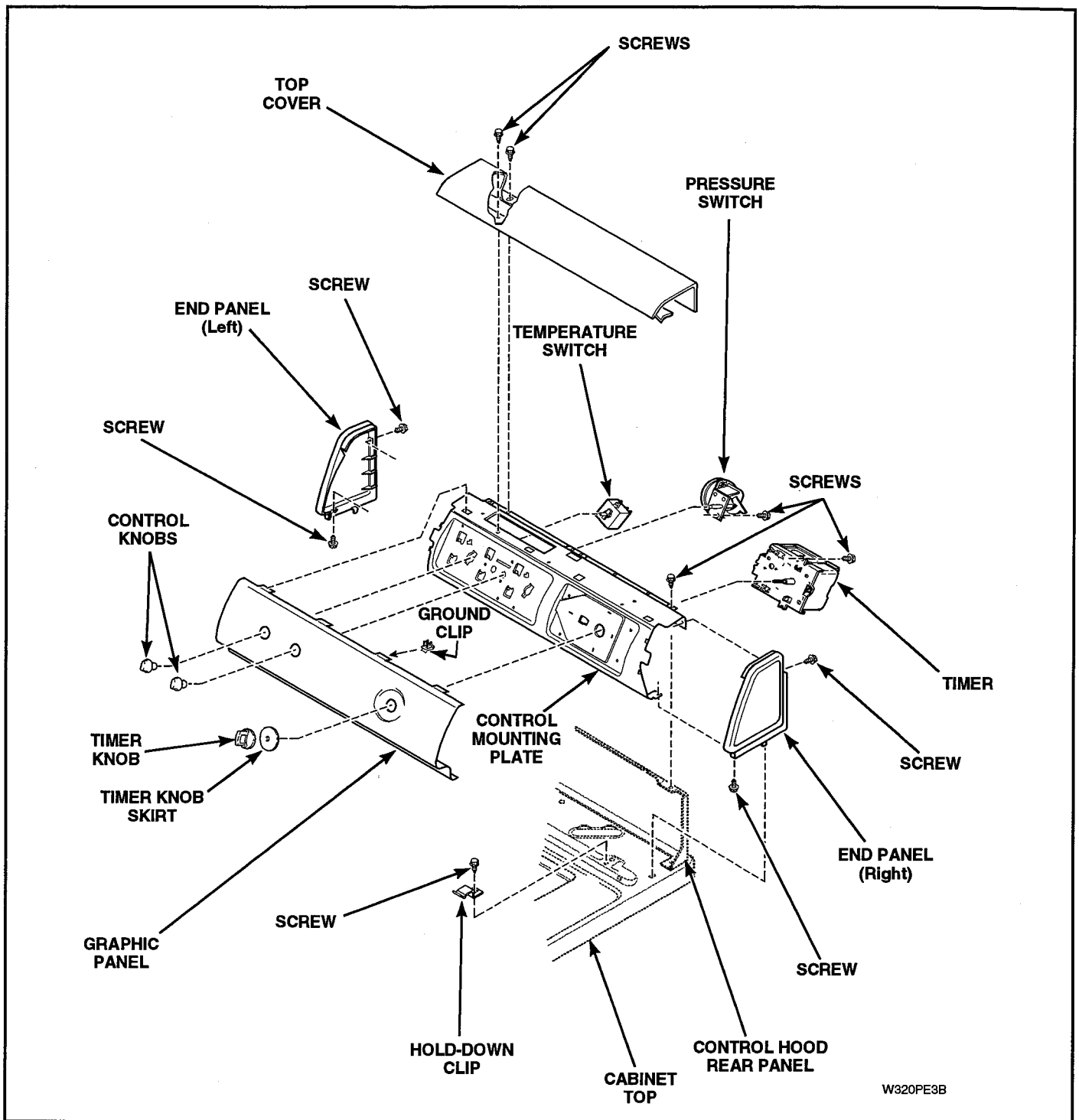

Figure 5-3

GRAPHIC PANEL, CONTROL MOUNTING PLATE AND CONTROLS
 (Models LWA20A*, LWD27*, LWD35A*, LWD37A*, and LWD40A*)

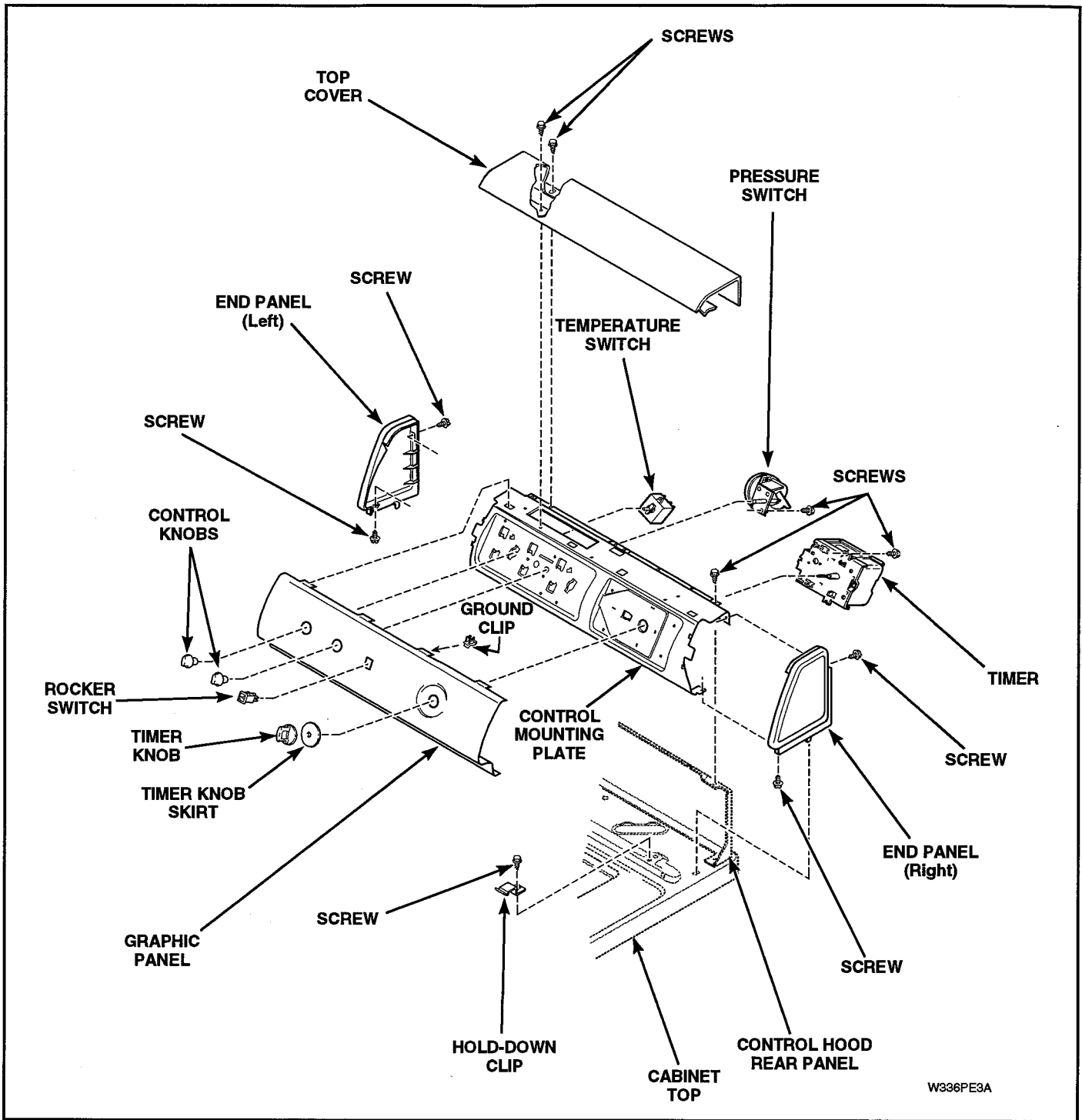
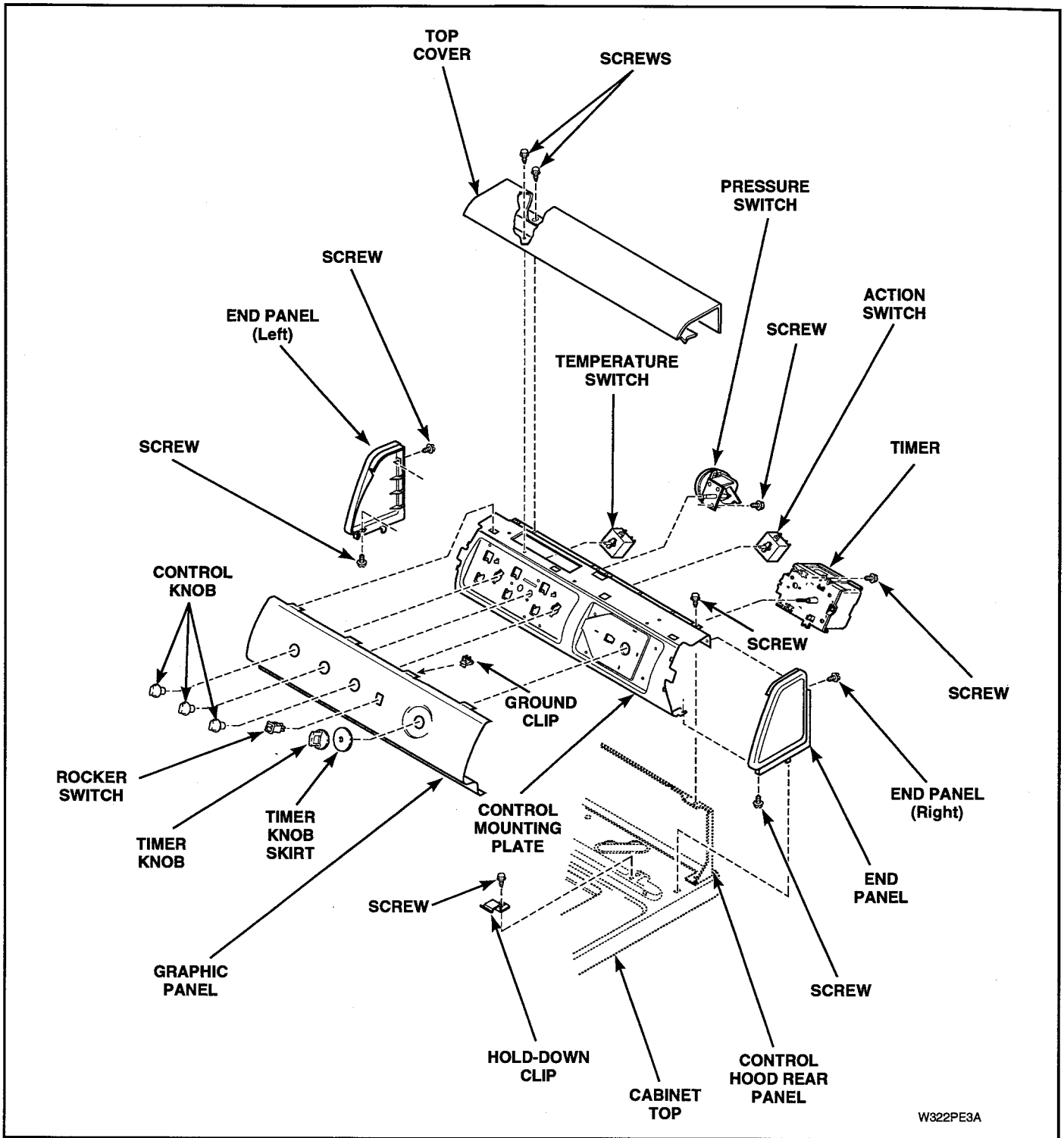

Figure 5-4

GRAPHIC PANEL, CONTROL MOUNTING PLATE AND CONTROLS
 (Models LWA50A*, LWC50A*, LWC75A*, and LWD75A*)



W322PE3A

Figure 5-5

GRAPHIC PANEL, CONTROL MOUNTING PLATE AND CONTROLS
 (Models LWA60A*, LWA80A*, and LWC80A*)

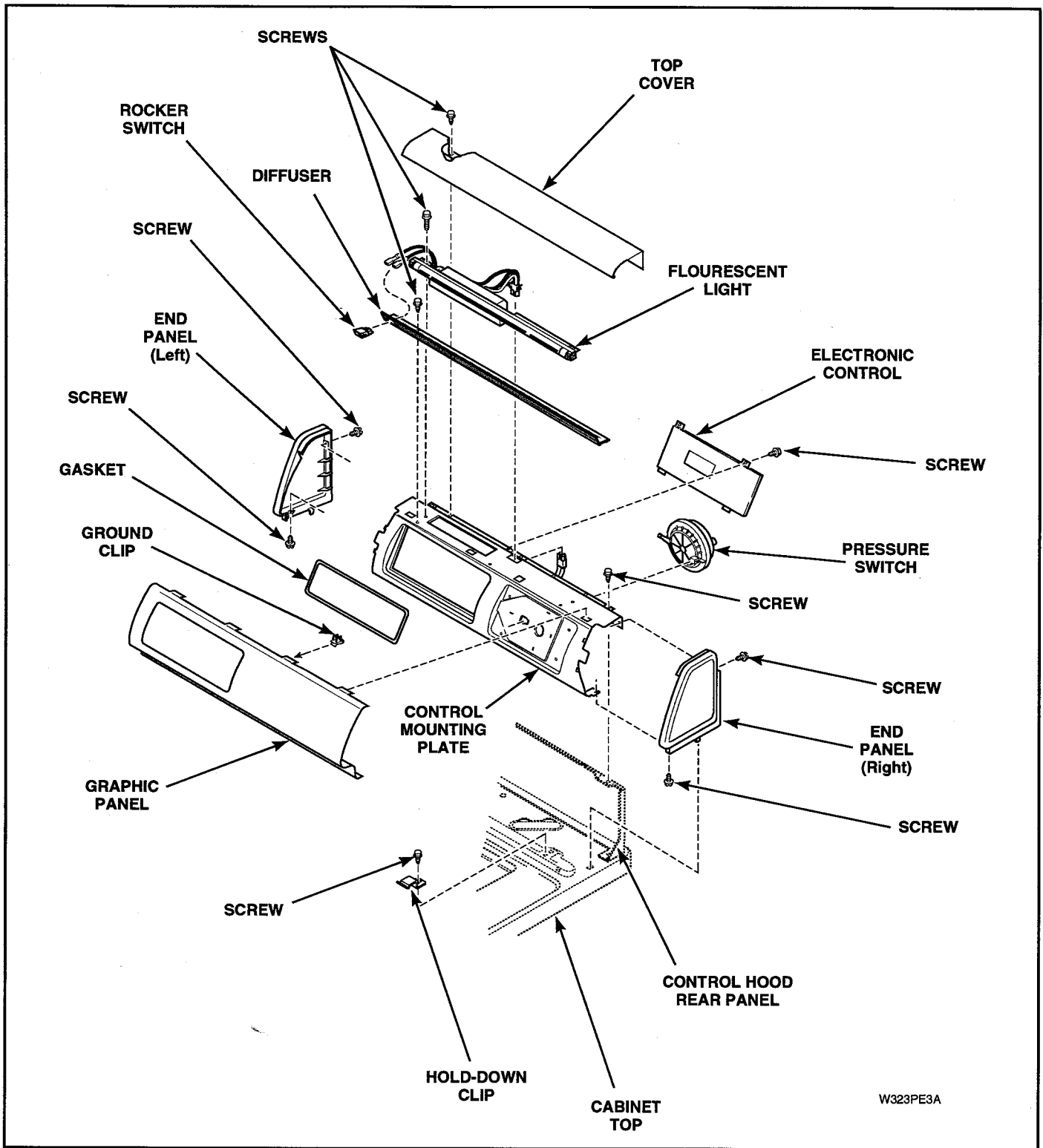

Figure 5-6

GRAPHIC PANEL, CONTROL MOUNTING PLATE AND CONTROLS
 (Models LWA90A*, and LWC90A*)



WARNING

To reduce the risk of electric shock, fire, explosion, serious injury or death:

- Disconnect electric power to the washer before servicing.
- Never start the washer with any guards/panels removed.
- Whenever ground wires are removed during servicing, these ground wires must be reconnected to ensure that the washer is properly grounded.

W003

3. TIMER (Refer to Figures 5-2 through 5-5)

- Unscrew timer knob from timer shaft (right hand thread), then remove timer knob skirt.
- Remove three screws holding rear of hood assembly to control hood rear panel.
See Figure 5-1.
- Pivot hood assembly forward on cabinet top.
See Figure 5-1.
- Remove two screws holding timer to control hood mounting plate. See Figure 5-7.

NOTE: DO NOT attempt to repair timer.

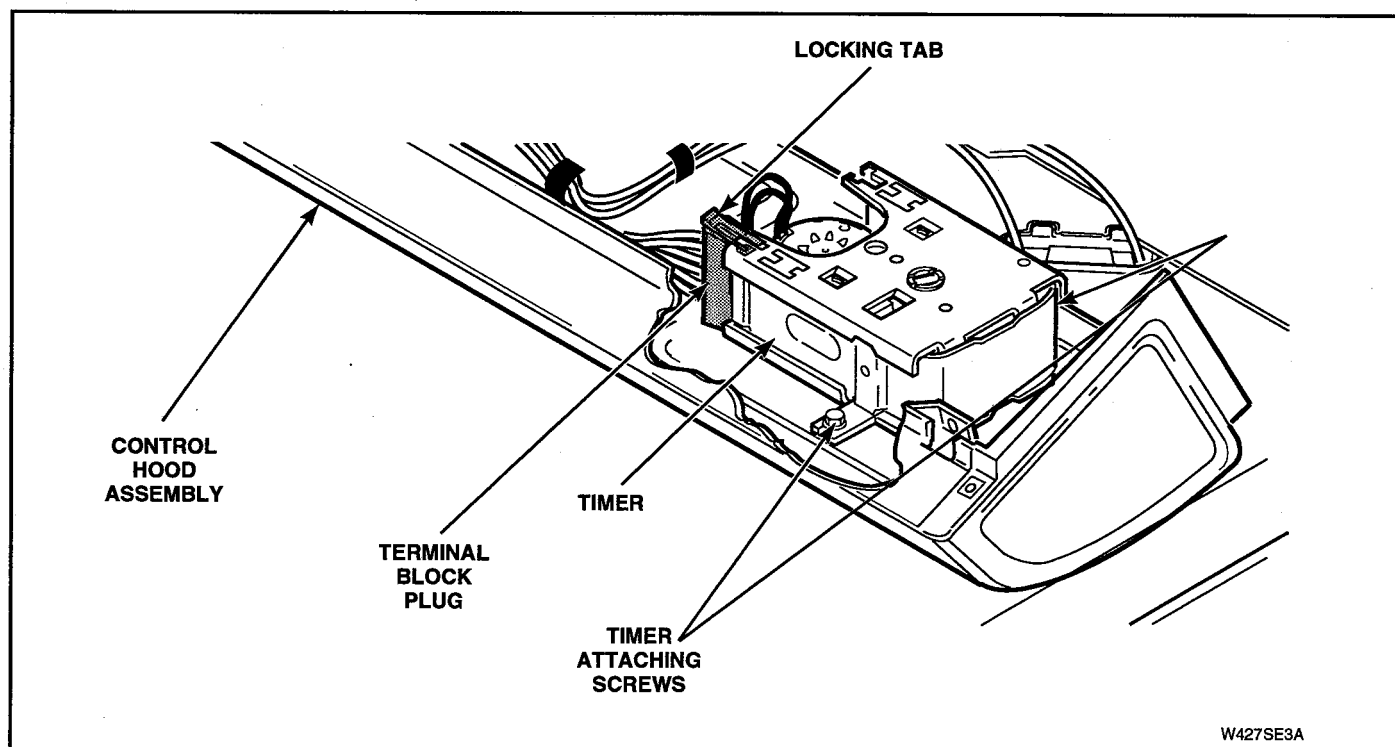

W427SE3A

Figure 5-7



WARNING

To reduce the risk of electric shock, fire, explosion, serious injury or death:

- Disconnect electric power to the washer before servicing.
- Never start the washer with any guards/panels removed.
- Whenever ground wires are removed during servicing, these ground wires must be reconnected to ensure that the washer is properly grounded.

W003

- e. Disengage wire harness terminal block plug(s) from timer by pressing in on movable locking tabs (located on each side of terminal block plug) and pulling away from timer. See Figure 5-7.

IMPORTANT: To avoid an open circuit, **DO NOT** pull on terminal block wires when removing blocks from timer as this could damage wires or terminal crimping.

Before attaching wire harness terminal blocks to timer, make sure all male terminals on timer are straight and are capable of accepting terminals from wire harness terminal blocks.

NOTE: When installing timer, make sure timer is installed correctly and is securely mounted to control mounting plate. See Figure 5-8.

- f. Seat horizontal and vertical tabs on front plate of timer completely into slots on control mounting plate. See Figure 5-8.
- g. Tighten attaching screws between 12 to 18 inch pounds (1.6 to 2.4 N-m).

IMPORTANT: To avoid timer damage, do not allow timer to be struck on corners, edges of frame, or on timer shaft.

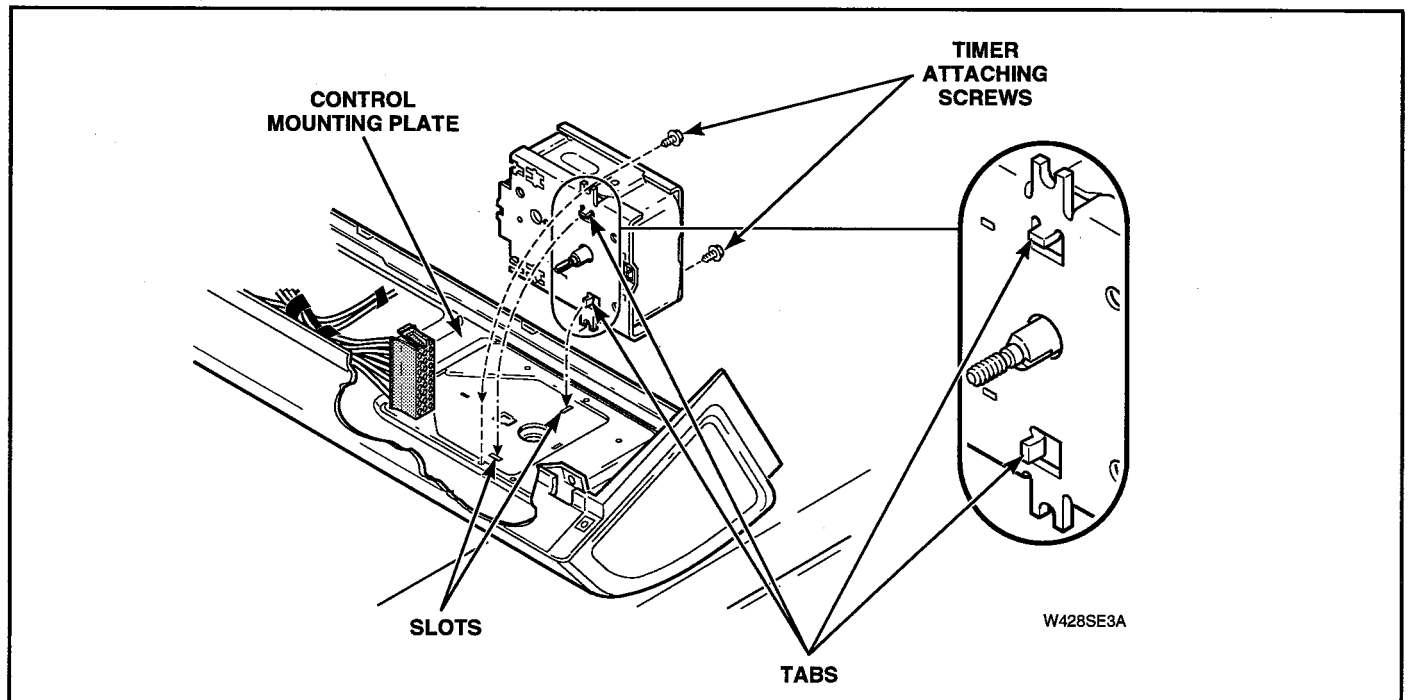

Figure 5-8

(continued)



WARNING

To reduce the risk of electric shock, fire, explosion, serious injury or death:

- Disconnect electric power to the washer before servicing.
- Never start the washer with any guards/panels removed.
- Whenever ground wires are removed during servicing, these ground wires must be reconnected to ensure that the washer is properly grounded.

W003

4. TEMPERATURE SWITCH

- Remove three screws holding rear of hood assembly to control hood rear panel.
See Figure 5-1.
- Pivot hood assembly forward on cabinet top.
See Figure 5-1.
- Disconnect wires from switch terminals.
- Refer to Figures 5-2 through 5-5 for switch removal.

NOTE: Refer to appropriate wiring diagram when rewiring switch.

5. PRESSURE SWITCH

- Remove three screws holding rear of hood assembly to control hood rear panel.
See Figure 5-1.
- Pivot hood assembly forward on cabinet top.
See Figure 5-1.
- Disconnect wires from pressure switch.
- Refer to Figures 5-2 through 5-6 for switch removal.

NOTE: Refer to appropriate wiring diagram when rewiring switch.

IMPORTANT: Before connecting hose to pressure switch, blow air through pressure hose to remove any condensation that may have accumulated in the hose.

6. GRAPHIC PANEL

(Refer to Figures 5-2 through 5-6)

- Unscrew timer knob from timer shaft (right hand thread), then remove timer knob skirt.
- Pull knob off switch shaft.
- Remove three screws holding rear of hood assembly to control hood rear panel.
See Figure 5-1.
- Pivot hood assembly forward on cabinet top.
See Figure 5-1.
- Disconnect wires from component parts and carefully remove components from control hood assembly.

NOTE: Refer to appropriate wiring diagram when rewiring component parts.

- Bend tabs on graphic panel (located inside of control hood) straight out toward rear of hood.
- Carefully remove graphic panel off front of control mounting plate



WARNING

To reduce the risk of electric shock, fire, explosion, serious injury or death:

- Disconnect electric power to the washer before servicing.
- Never start the washer with any guards/panels removed.
- Whenever ground wires are removed during servicing, these ground wires must be reconnected to ensure that the washer is properly grounded.

W003

7. LOADING DOOR

- Open loading door. See Figure 5-9.
- Remove two screws holding left hinge to door and remove hinge. See Figure 5-9.
- Raise loading door to a nearly vertical position, to disengage loading door from loading door clip, swing left side of door toward front of washer. See Figure 5-10, **procedure one**.
- Rotate loading door so door is upside down. See Figure 5-10, **procedure two**.
- Carefully remove loading door, right hinge and bushing from cabinet top. See Figure 5-10, **procedure three**.

NOTE: Reverse procedure when installing door.

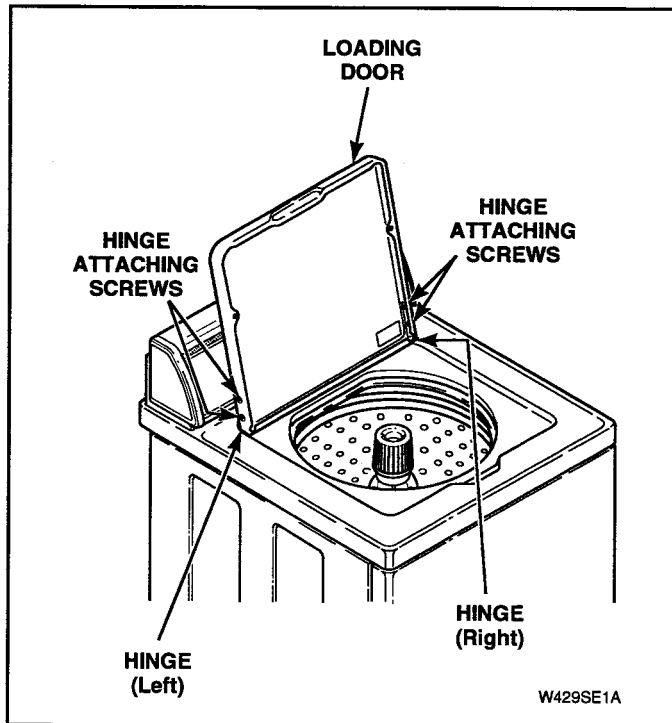

Figure 5-9

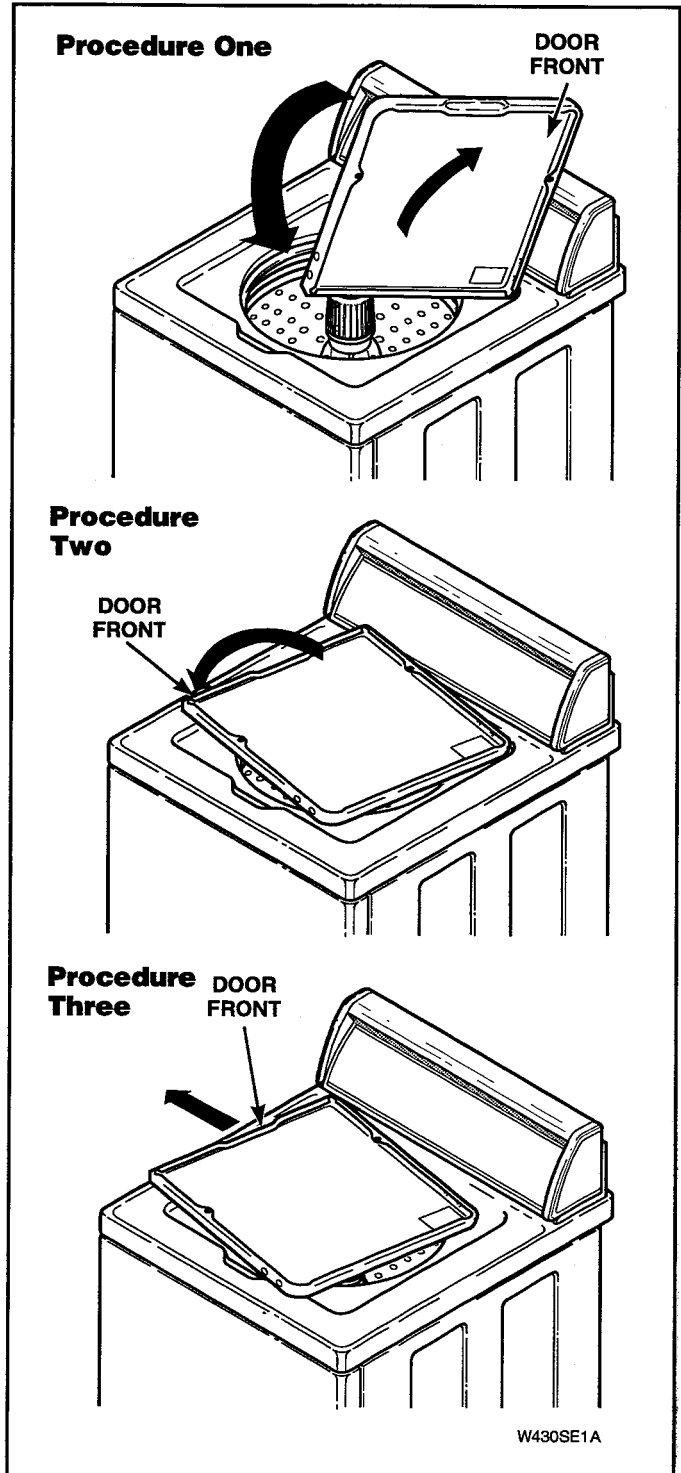

Figure 5-10



WARNING

To reduce the risk of electric shock, fire, explosion, serious injury or death:

- Disconnect electric power to the washer before servicing.
- Never start the washer with any guards/panels removed.
- Whenever ground wires are removed during servicing, these ground wires must be reconnected to ensure that the washer is properly grounded.

W003

8. AGITATOR

- Open loading door.
- Remove agitator by placing two agitator hooks, No. 254P4P, under bottom edge of agitator. See Figure 5-11.

IMPORTANT: Hooks should be positioned 180 degrees from each other, and must be placed under base of agitator near agitator vane for greater stability. If hooks are placed between the vane area, agitator damage may occur.

- Using a rocking motion (back and forth) carefully lift agitator off drive bell.

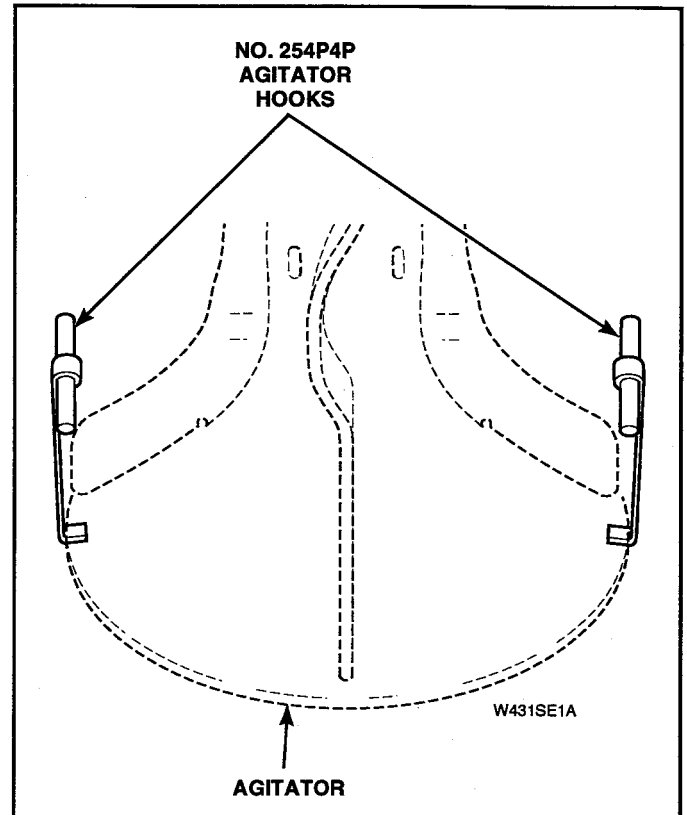

Figure 5-11



WARNING

To reduce the risk of electric shock, fire, explosion, serious injury or death:

- Disconnect electric power to the washer before servicing.
- Never start the washer with any guards/panels removed.
- Whenever ground wires are removed during servicing, these ground wires must be reconnected to ensure that the washer is properly grounded.

W003

9. AGITATOR, DRIVE BELL AND SEAL ASSEMBLY

IMPORTANT: If water is present in washtub, spin and pump out before attempting to remove drive bell.

- Remove agitator, paragraph 8.
- Remove plug, screw and "O" ring from top of drive bell.

NOTE: Use No. 294P4 Drive Bell Tool to remove drive bell from transmission shaft.

NOTE: Drive Bell Tool, No. 253P4, must be updated with Jaws, No. 294P4A, and Bolt, No. 294P4B, to remove the 36443P Drive Bell.

- Back bolt out of 294P4 Drive Bell Tool approximately three quarters of the way. See Figure 5-12.
- Place tool over drive bell, making sure indent on jaws line up with wide slots on drive bell. See Figure 5-13.

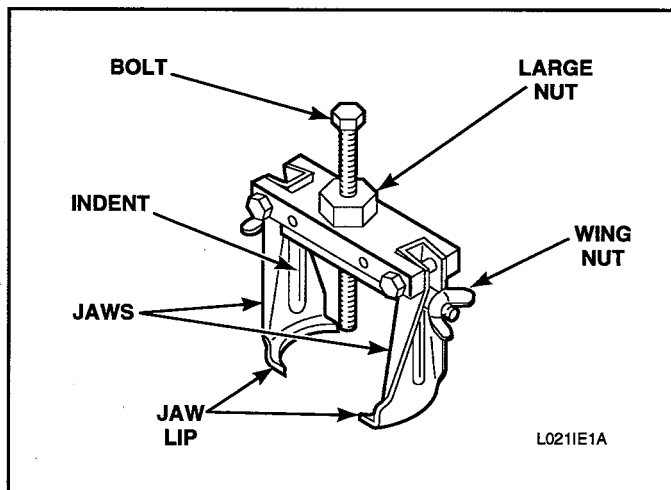

Figure 5-12

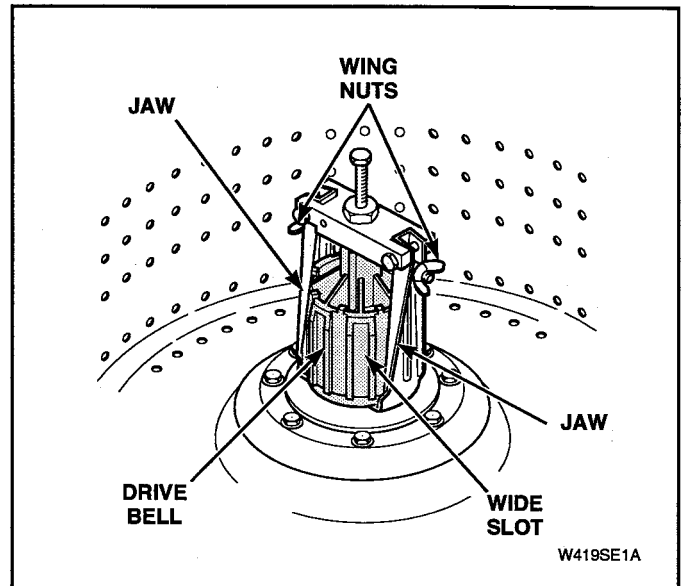

Figure 5-13

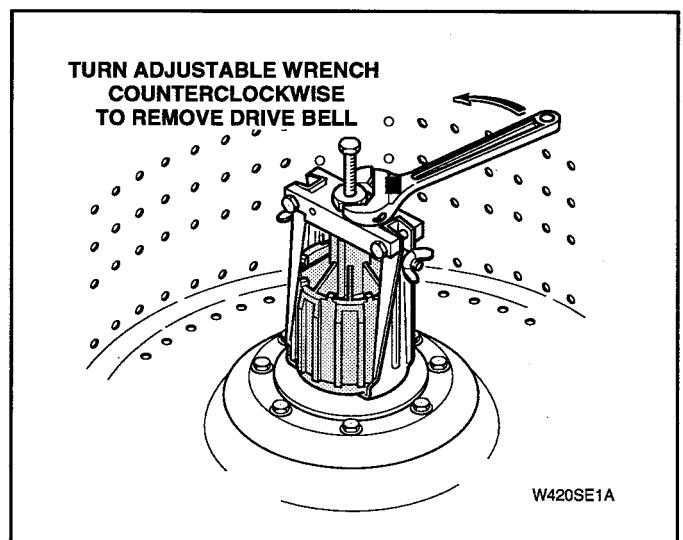

Figure 5-14



WARNING

To reduce the risk of electric shock, fire, explosion, serious injury or death:

- Disconnect electric power to the washer before servicing.
- Never start the washer with any guards/panels removed.
- Whenever ground wires are removed during servicing, these ground wires must be reconnected to ensure that the washer is properly grounded.

W003

- Thread bolt down through hole in top of drive bell until it bottoms out.
- Place lip of each jaw under bottom edge of drive bell, making sure indent on jaws line up with wide slots on drive bell. Tighten wing nuts on tool to hold jaws firmly against drive bell. See Figure 5-13.
- Using an adjustable wrench, turn large nut on tool **COUNTERCLOCKWISE** to pull drive bell from transmission output shaft. See Figure 5-14.

IMPORTANT: If large nut is turned clockwise when pulling drive bell, you will twist off the quarter inch bolt.

- After drive bell has been pulled, remove tool and drive bell by turning quarter inch bolt out of transmission output shaft.
- Loosen wing nuts and remove drive bell from tool.
- Remove old seal from hub assembly by:
 - Placing a flat bladed screwdriver between bottom edge of seal and hub.
 - Using washtub bolts as a pry area, pop off lower seal bead.
 - Grasping bottom of seal pull straight up freeing upper seal bead.

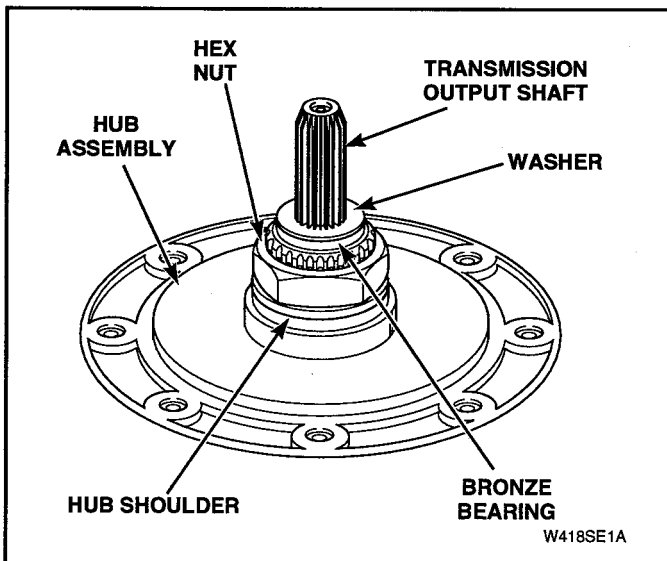

Figure 5-15

- Thoroughly clean all foreign material from seal mounting area of hub assembly, bronze bearing and washer. See Figure 5-15.
- Lubricate new seal with liquid soap or soapy water to aid in assembly of seal onto hub. See Figure 5-16.
- Apply a small amount of supplied grease, No. 36765P, to inside sealing lips of seal. See Figure 5-16.

IMPORTANT: DO NOT allow any lubricants to come in contact with outside surface of seal.

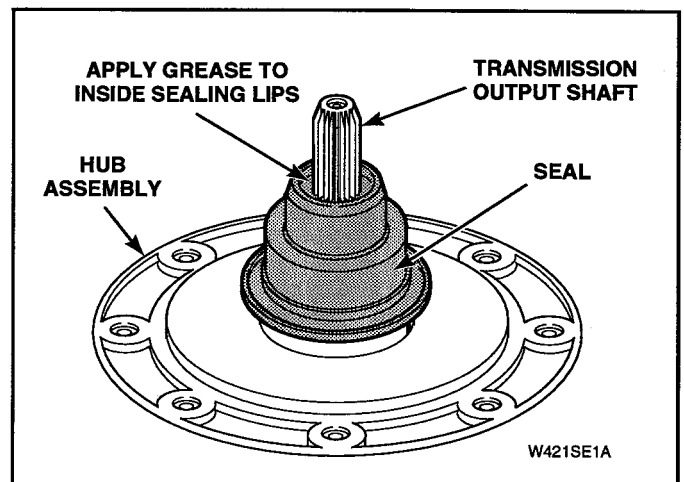

Figure 5-16

- Apply remainder of supplied grease, No. 36765P, to exposed surface of washer between transmission output shaft and seal. See Figure 5-18.
- Place new drive bell seal onto hub and carefully push into position using large end of No. 293P4 Seal Tool. See Figure 5-17.

IMPORTANT: Using a small pocket mirror, check entire circumference of bottom seal flange to make sure seal is pressed down against shoulder on hub; there should be no gap!

(continued)



WARNING

To reduce the risk of electric shock, fire, explosion, serious injury or death:

- Disconnect electric power to the washer before servicing.
- Never start the washer with any guards/panels removed.
- Whenever ground wires are removed during servicing, these ground wires must be reconnected to ensure that the washer is properly grounded.

W003

- p. Turn the No. 293P4 Seal Tool upside-down and place the small end over transmission output shaft and onto the seal. See Figure 5-18.
- q. Push down on tool with a quick motion until it bottoms out and the top of seal is fully seated. See Figure 5-18.

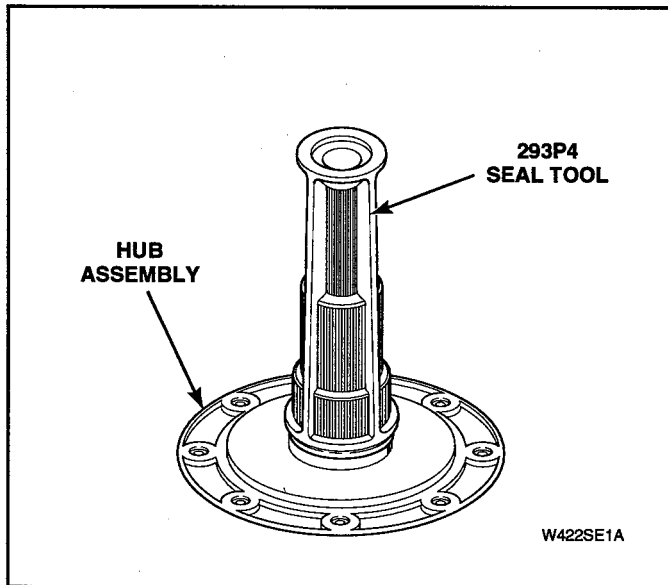

Figure 5-17

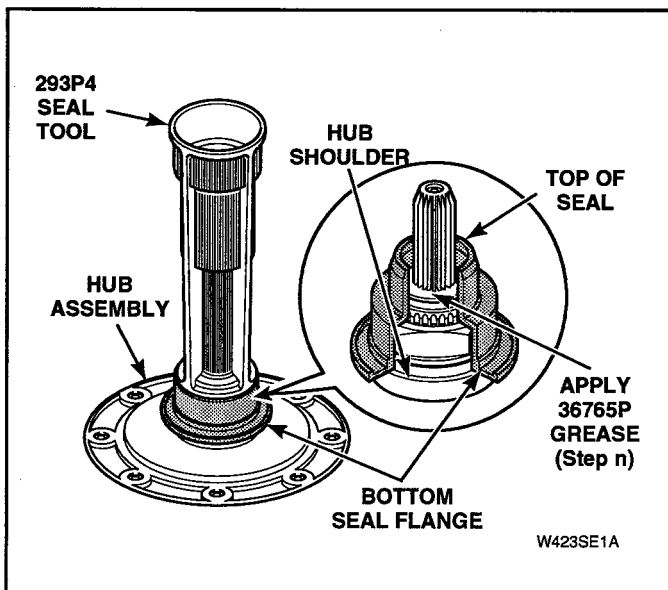

Figure 5-18

INSTALLING DRIVE BELL

- a. Position new drive bell over transmission output shaft. Rotate drive bell until splines in drive bell line up with splines on transmission output shaft.
- b. Place No. 294P4 Bell Tool over top of drive bell. Screw bolt into transmission output shaft until it bottoms out.

NOTE: It is not necessary to clamp tool jaws on drive bell during this operation.

- c. Using an adjustable wrench, turn large nut on tool **CLOCKWISE** to force drive bell down onto transmission shaft until drive bell bottoms out on shaft.
- d. Turn quarter inch bolt out of transmission shaft and remove tool.
- e. Place new "O" ring onto new shoulder screw. Thread shoulder screw down through hole in top of drive bell and into transmission shaft.

NOTE: Tighten new shoulder screw to approximately 60 to 80 inch-pounds (6.86 to 9.15 N-m).

- f. Place new plug over hole in drive bell and firmly press into place using palm of your hand.

NOTE: It may be necessary to insert the end of a paper clip along side of plug as it is pressed into drive bell to release entrapped air.

IMPORTANT: When fully seated plug should not extend above drive bell more than 1/8 inch (3.2 mm).

- g. Place agitator on top of drive bell. Slowly rotate agitator until fingers on underside of agitator line up with large slots on drive bell.
- h. A sharp blow on top of agitator, with palm of your hand, will force agitator down onto drive bell, allowing fingers on underside of agitator to lock under bottom edge of drive bell.

NOTE: Do not push agitator onto drive bell any further than necessary.



WARNING

To reduce the risk of electric shock, fire, explosion, serious injury or death:

- Disconnect electric power to the washer before servicing.
- Never start the washer with any guards/panels removed.
- Whenever ground wires are removed during servicing, these ground wires must be reconnected to ensure that the washer is properly grounded.

W003

10. FRONT PANEL

NOTE: Screws at bottom edge of front panel do not have to be removed as the holes in front panel are slotted.

NOTE: Top edge of front panel is held in place by two spring clips located on bottom flange of cabinet top. See Figure 5-19.

- Insert putty knife between cabinet top and top edge of front panel (approximately three inches in from side). See Figure 5-19.
- Push in on putty knife and at the same time pull top edge of front panel away from front of washer. Repeat for opposite side.
- Lift front panel off two screws and set panel aside.

PANEL LOCATORS

Remove screws holding panel locators to side flanges of front panel.

BRACE

Remove screws holding brace to side flanges of front panel. Remove brace from front panel by swinging one end toward bottom of front panel and remove brace.

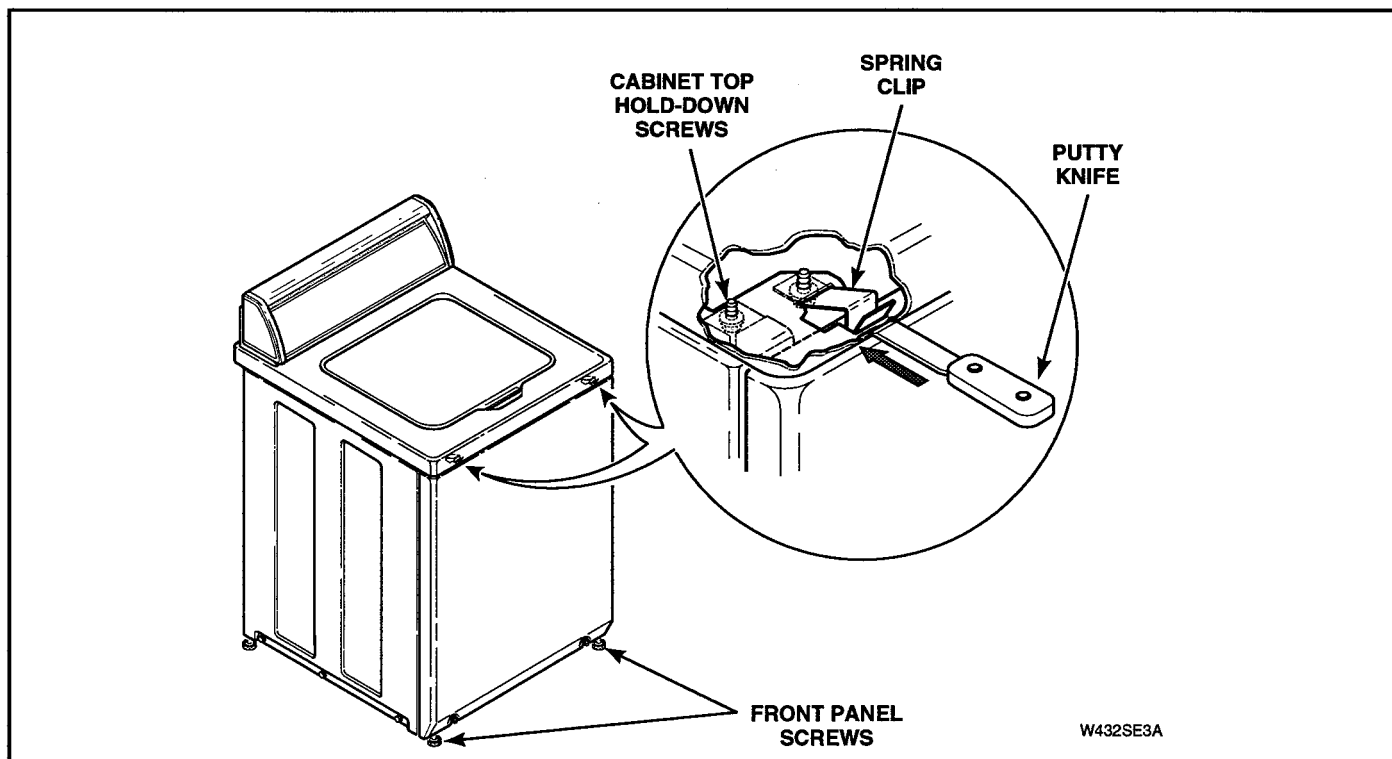

W432SE3A

Figure 5-19



WARNING

To reduce the risk of electric shock, fire, explosion, serious injury or death:

- Disconnect electric power to the washer before servicing.
- Never start the washer with any guards/panels removed.
- Whenever ground wires are removed during servicing, these ground wires must be reconnected to ensure that the washer is properly grounded.

W003

11. MOTOR AND MOUNTING BRACKET

NOTE: Screws at bottom edge of front panel do not have to be removed as the holes in front panel are slotted.

NOTE: Top edge of front panel is held in place by two spring clips located on bottom flange of cabinet top. See Figure 5-16.

- a. Insert putty knife between cabinet top and top edge of front panel (approximately three inches in from side). See Figure 5-19.
- b. Push in on putty knife and at the same time pull top edge of front panel away from front of washer. Repeat for opposite side.
- c. Lift front panel off two screws and set panel aside.

IMPORTANT: There will always be some water that will remain in outer tub, therefore, before removing hoses from pump, hoses must be pinched off or drained to prevent water spillage.

- d. Loosen hose clamps and remove hoses from pump assembly. See Figure 5-20.
- e. Unhook idler spring from clip on front of motor mounting bracket. See Figure 5-20.

IMPORTANT: Use care when releasing idler lever tension. If idler spring is overstretched, washer operation will be affected.

- f. Reach in and around right side of motor and run belt off right side of large drive pulley. See Figure 5-20.
- g. Disconnect wire harness from motor switch by pressing down on locking tab on top of connection block and at the same time pull connection block away from motor switch. See Figure 5-21.
- h. Remove four screws holding motor and mounting bracket to lower outer tub flange and to weldment assembly. See Figure 5-21. Then lift complete assembly out of washer.

IMPORTANT: Carefully lay motor on its side. Observe belt configuration around rear pump leg. Belt **MUST** encircle rear pump leg when reassembling. See Figure 5-22.



WARNING

To reduce the risk of electric shock, fire, explosion, serious injury or death:

- Disconnect electric power to the washer before servicing.
- Never start the washer with any guards/panels removed.
- Whenever ground wires are removed during servicing, these ground wires must be reconnected to ensure that the washer is properly grounded.

W003

PUMP AND BELT REMOVAL

- a. Remove three screws holding pump assembly to motor. See Figure 5-22.

REASSEMBLY OF PUMP AND BELT

IMPORTANT: Install pump and belt together. Drive belt **MUST** be replaced with belt No. 37820 for one and two speed models; or 38174 for three speed models (special clutch-type belt) for proper washer operation.

- a. Clean any corrosion or foreign material from motor shaft that will be contacting the double "D" slot in pump impeller.
- b. Apply a thin film of No. 03637P Lubricant to end and sides of motor shaft. This lubricant helps keep moisture out of the hub area and retards corrosion.
- c. Align pump impeller hub with motor shaft. Make sure belt encircles rear pump leg, carefully push pump onto motor shaft so three pump legs bottom out in the embosses on motor housing before screws are tightened. See Figure 5-22.
- d. Tighten three screws to 35 inch-pounds (4.0 N-m) maximum. **DO NOT** overtighten screws!
- e. Reinstall motor and pump assembly into washer.

IMPORTANT: After installing motor and pump assembly in washer and all hoses have been reconnected, add at least a quart of water to washtub to lubricate pump seals. Running a pump without water will ruin the seals.

MOTOR REMOVAL

Remove nuts, steel washers, spacers and rubber mounts holding motor to mounting bracket. See Figure 5-23. Lift motor off mounting bracket and remove balance of rubber mounts and steel washers from motor mounting studs.

IMPORTANT: When installing motor on mounting bracket, position motor with switch facing toward left side of mounting bracket.

NOTE: Refer to Figure 5-23 for motor and mounting bracket assembly sequence.

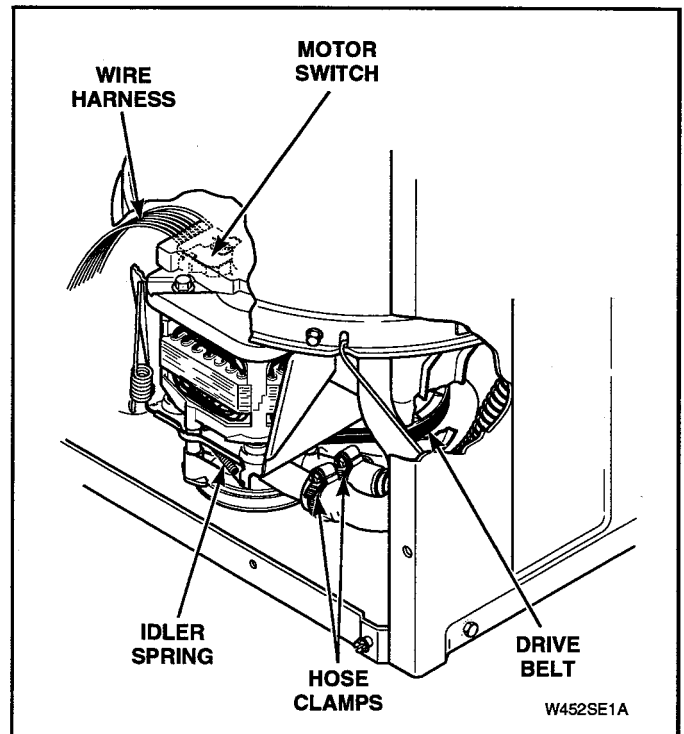

Figure 5-20



WARNING

To reduce the risk of electric shock, fire, explosion, serious injury or death:

- Disconnect electric power to the washer before servicing.
- Never start the washer with any guards/panels removed.
- Whenever ground wires are removed during servicing, these ground wires must be reconnected to ensure that the washer is properly grounded.

W003

12. IDLER LEVER AND PULLEY

NOTE: Screws located at bottom edge of front panel do not have to be removed as the holes in front panel are slotted.

NOTE: Top edge of front panel is held in place by two spring clips located on bottom flange of cabinet top. See Figure 5-19.

- a. Insert putty knife between cabinet top and top edge of front panel (approximately three inches in from side). See Figure 5-19.
- b. Push in on putty knife and at the same time pull top edge of front panel away from front of washer. Repeat for opposite side.
- c. Lift front panel off two screws and set panel aside.

IMPORTANT: There will always be some water that will remain in outer tub, therefore, before removing hoses from pump, hoses must be pinched off or drained to prevent water spillage.

- d. Loosen hose clamps and remove hoses from pump assembly. See Figure 5-21.
- e. Unhook idler spring from idler lever. See Figure 5-21.

IMPORTANT: Use care when removing idler spring. If idler spring is overstretched, washer operation will be affected.

- f. Reach in and around right side of motor and run belt off right side of large drive pulley. See Figure 5-21.
- g. Disconnect wire harness from motor switch by pressing down on locking tab on top of connection block and at the same time pull connection block away from motor switch. See Figure 5-21.
- h. Remove four screws holding motor mounting bracket to lower flange of outer tub and to weldment assembly. See Figure 5-21. Then remove complete assembly out of washer.
- i. Remove nut, washer and bolt holding idler lever and pulley to motor mounting bracket. See Figure 5-23.

NOTE: Refer to Figure 5-23 for idler lever and pulley assembly sequence.

- j. Apply a light film of No. 03637P Lubricant to area of idler lever that makes contact with motor mounting bracket.

IMPORTANT: DO NOT OVER LUBRICATE! Excess lubricant can be thrown into pivot dome area during normal washer operation. Any lubricant on pivot dome, base or friction ring will affect washer operation.

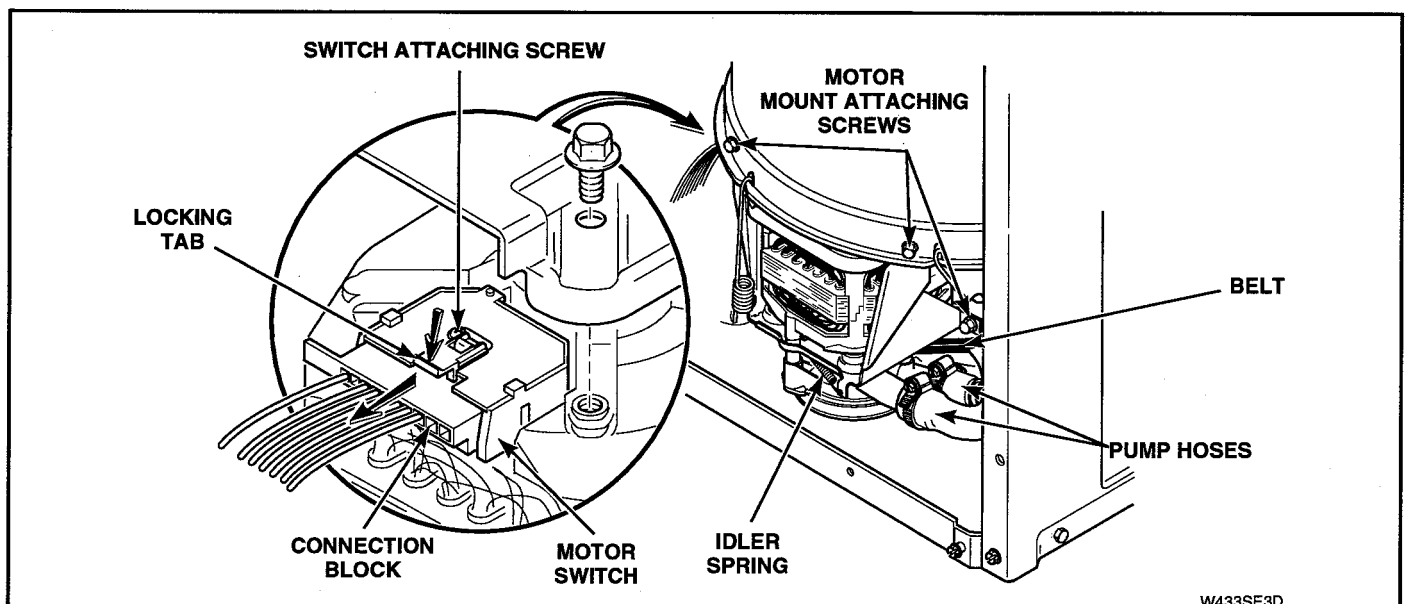

Figure 5-21



WARNING

To reduce the risk of electric shock, fire, explosion, serious injury or death:

- Disconnect electric power to the washer before servicing.
- Never start the washer with any guards/panels removed.
- Whenever ground wires are removed during servicing, these ground wires must be reconnected to ensure that the washer is properly grounded.

W003

13. MOTOR DRIVE PULLEY

NOTE: Screws located at bottom edge of front panel do not have to be removed as the holes in front panel are slotted.

NOTE: Top edge of front panel is held in place by two spring clips located on bottom flange of cabinet top. See Figure 5-19.

- a. Insert putty knife between cabinet top and top edge of front panel (approximately three inches in from side). See Figure 5-19.
- b. Push in on putty knife and at the same time pull top edge of front panel away from front of washer. Repeat for opposite side.
- c. Lift front panel off two screws and set panel aside.

IMPORTANT: There will always be some water that will remain in outer tub, therefore, before removing hoses from pump, hoses must be pinched off or drained to prevent water spillage.

- d. Loosen hose clamps and remove hoses from pump assembly. See Figure 5-20.
- e. Unhook idler spring from idler lever. See Figure 5-20.

IMPORTANT: Use care when removing idler spring. If idler spring is overstretched, washer operation will be affected.

- f. Reach in and around right side of motor and run belt off right side of large drive pulley. See Figure 5-20.
- g. Disconnect wire harness from motor switch by pressing down on locking tab on top of connection block and at the same time pull connection block away from motor switch. See Figure 5-21.
- h. Remove four screws holding motor and mounting bracket to lower flange of outer tub and to weldment assembly. See Figure 5-21. Then remove complete assembly out of washer.
- i. Lay motor assembly on its side.

NOTE: To remove pulley, support motor shaft (to prevent bending shaft) and drive out pulley roll pin. See Figure 5-23.

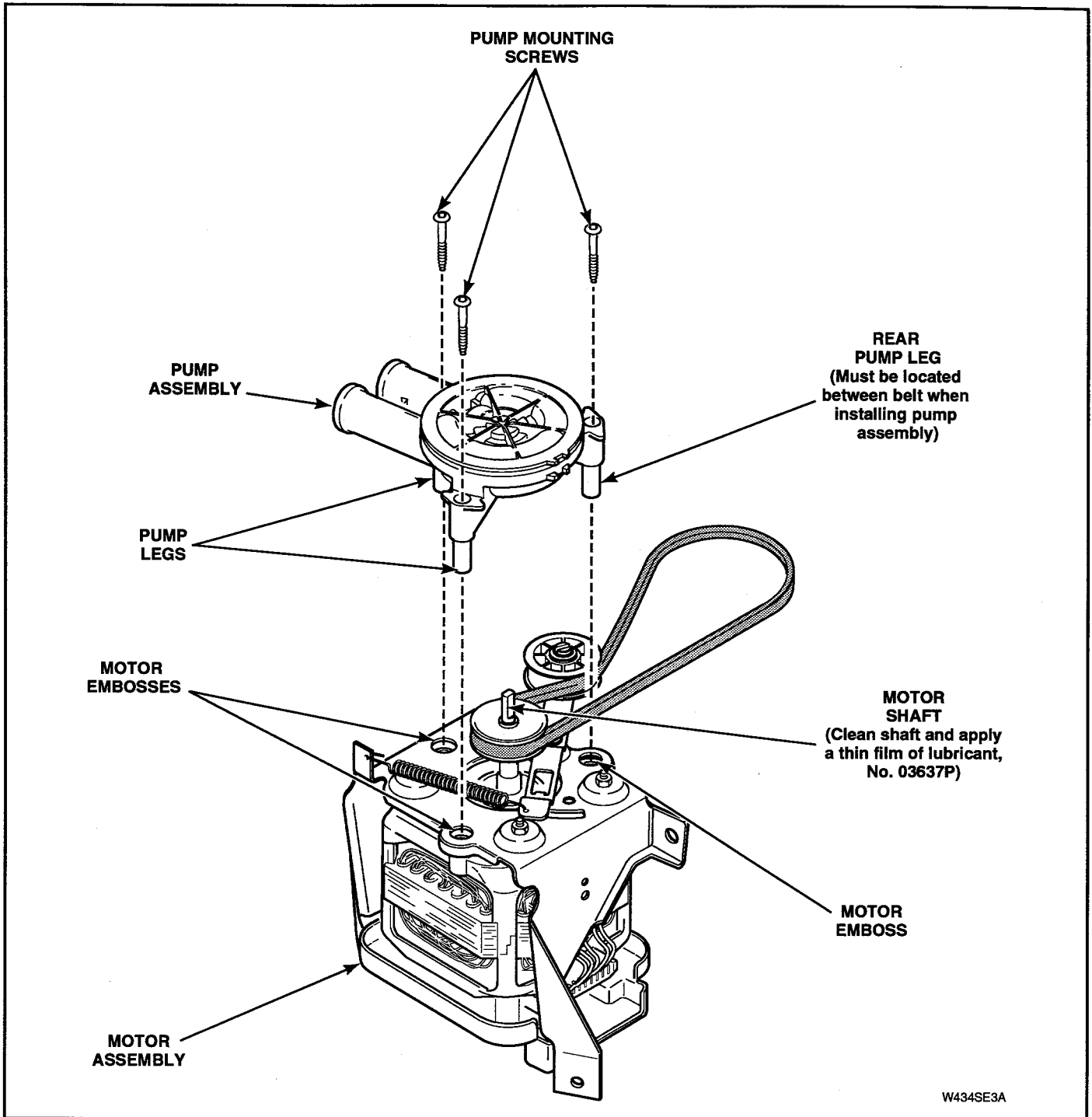
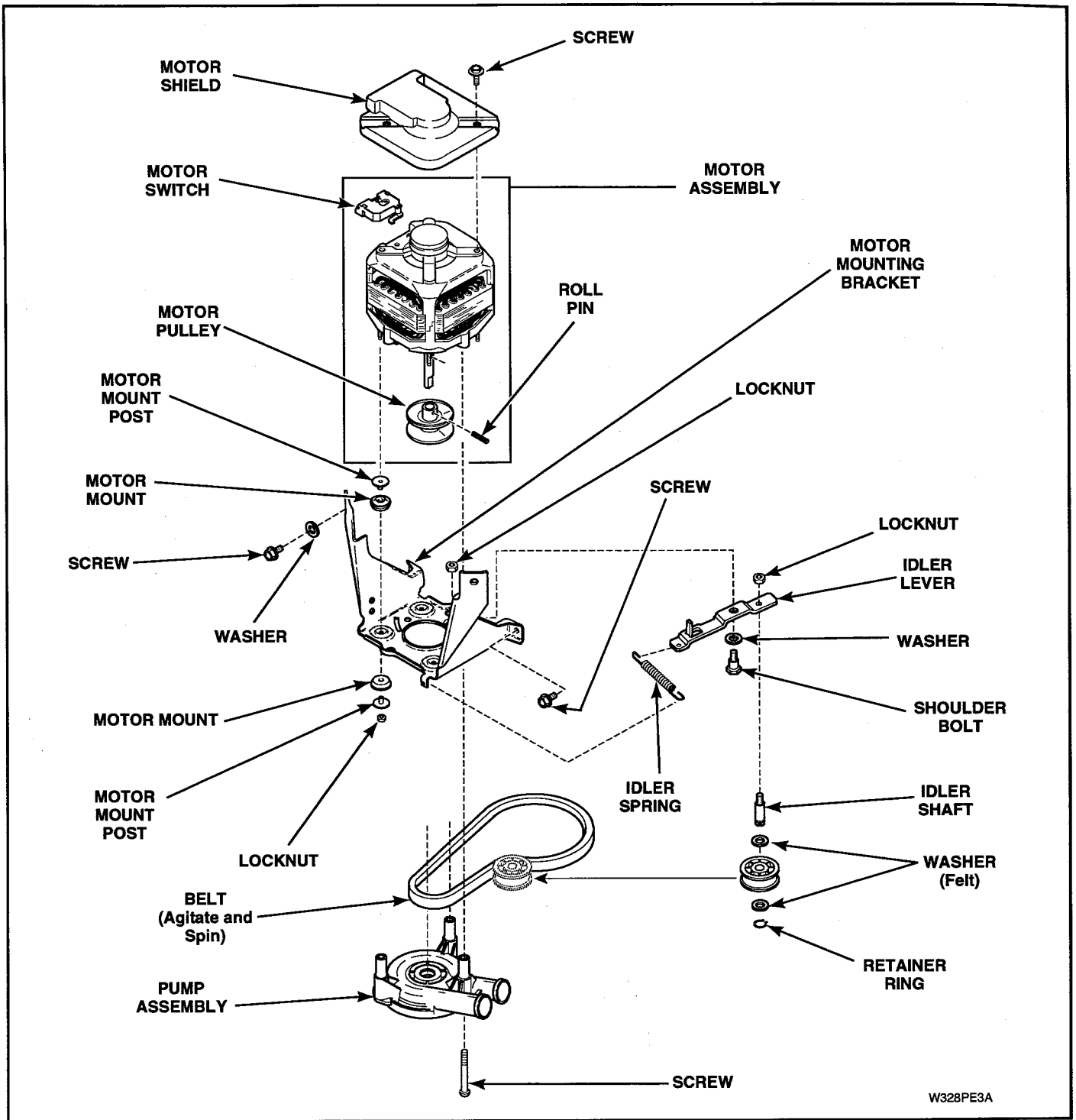

Figure 5-22



W328PE3A

Figure 5-23



WARNING

To reduce the risk of electric shock, fire, explosion, serious injury or death:

- Disconnect electric power to the washer before servicing.
- Never start the washer with any guards/panels removed.
- Whenever ground wires are removed during servicing, these ground wires must be reconnected to ensure that the washer is properly grounded.

W003

14. MOTOR SWITCH

NOTE: Screws at bottom edge of front panel do not have to be removed as the holes in front panel are slotted.

NOTE: Top edge of front panel is held in place by two spring clips located on bottom flange of cabinet top. See Figure 5-24.

- Insert putty knife between cabinet top and top edge of front panel (approximately three inches in from side). See Figure 5-24.
- Push in on putty knife and at the same time pull top edge of front panel away from front of washer. Repeat for opposite side.
- Lift front panel off two screws and set panel aside.
- Remove two screws holding motor shield to motor. See Figure 5-21.

- Disconnect wire harness from motor switch by pressing down on locking tab on top of connection block and at the same time pull connection block away from motor switch. See Figure 5-21.

IMPORTANT: To avoid an open circuit, **DO NOT** pull on terminal block wires when removing block from motor switch as this could damage wires or connection crimpings. Before attaching wire harness connection block to motor switch, make sure all male terminals on motor switch are straight and are capable of accepting terminals from wire harness connection block.

- Remove screw holding motor switch to motor. See Figure 5-21. Then remove switch.
- Disconnect internal motor leads from motor switch terminals.

NOTE: Refer to Wiring Schematics, SECTION 10 for rewiring internal motor switch wires.

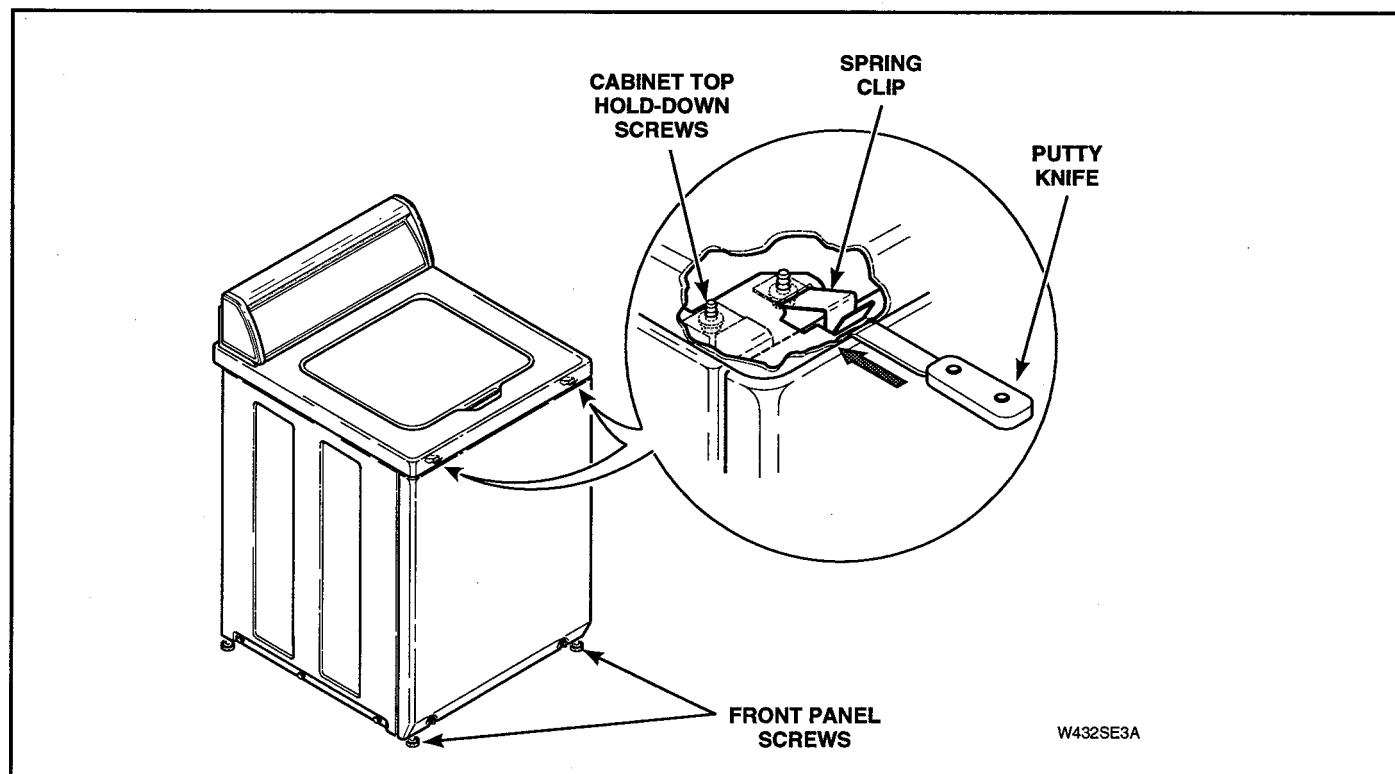

Figure 5-24



WARNING

To reduce the risk of electric shock, fire, explosion, serious injury or death:

- Disconnect electric power to the washer before servicing.
- Never start the washer with any guards/panels removed.
- Whenever ground wires are removed during servicing, these ground wires must be reconnected to ensure that the washer is properly grounded.

W003

15. CABINET TOP ASSEMBLY

NOTE: Screws at bottom edge of front panel do not have to be removed as the holes in front panel are slotted.

NOTE: Top edge of front panel is held in place by two spring clips located on bottom flange of cabinet top. See Figure 5-24.

- Insert putty knife between cabinet top and top edge of front panel (approximately three inches in from side). See Figure 5-24.
- Push in on putty knife and at the same time pull top edge of front panel away from front of washer. Repeat for opposite side.
- Lift front panel off two screws and set panel aside.
- Remove two cabinet top hold-down screws. See Figure 5-24.
- If area or space permits, tape loading door closed and lift cabinet top to a vertical position by hinging it on the rear hold-down bracket.

NOTE: Cabinet top is self-supporting, however, a small chain may be used for additional support. See Figure 5-25.

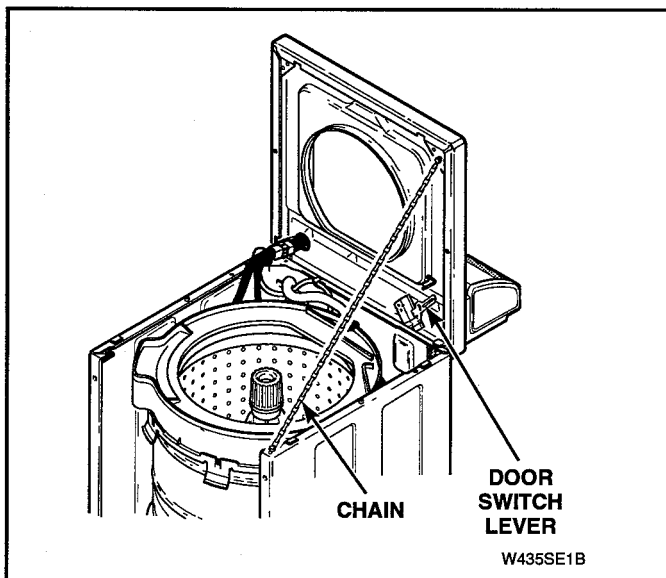

Figure 5-25

TO REMOVE CABINET TOP FROM WASHER

- Repeat steps "a", "b", "c", "d", and "e" above.
 - Remove three screws holding rear of hood assembly to control hood rear panel. See Figure 5-1. Pivot hood assembly forward on cabinet top. See Figure 5-1.
 - Loosen hose clamp and remove pressure hose from pressure bulb.
 - Then remove pressure hose from clips located on mixing valve cabinet flange and the top flange at rear of cabinet. See Figure 5-28.
 - Disconnect wire harness at disconnect blocks.
 - Tape loading door closed.
 - Lift front of cabinet top slightly and pull forward to disengage from rear hold-down brackets.
 - Pull top forward far enough to permit disconnecting ground wires from top left rear corner gusset of washer cabinet. See Figure 5-26.
 - Disconnect wires from mixing valve solenoids at quick disconnect blocks. See Figure 5-26.
- IMPORTANT:** Refer to appropriate wiring diagram when rewiring mixing valve solenoids.
- Carefully lift cabinet top off washer and set alongside the washer cabinet on protective padding.

IMPORTANT: DO NOT lay cabinet top flat because it will damage door switch lever.

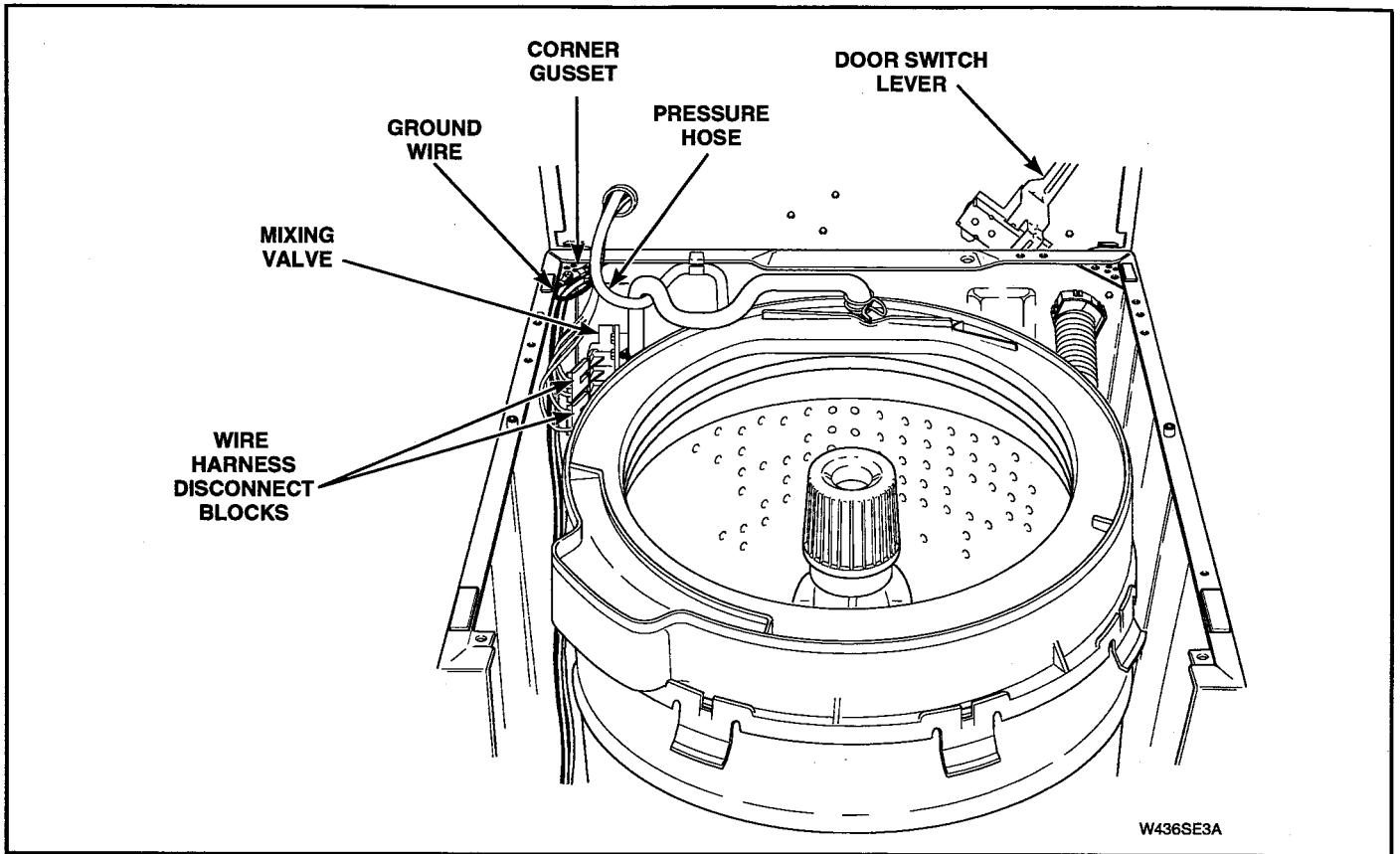

Figure 5-26



WARNING

To reduce the risk of electric shock, fire, explosion, serious injury or death:

- Disconnect electric power to the washer before servicing.
- Never start the washer with any guards/panels removed.
- Whenever ground wires are removed during servicing, these ground wires must be reconnected to ensure that the washer is properly grounded.

W003

16. DOOR SWITCH

NOTE: Screws located at bottom edge of front panel do not have to be removed as the holes in front panel are slotted.

NOTE: Top edge of front panel is held in place by two spring clips located on bottom flange of cabinet top. See Figure 5-19.

- Insert putty knife between cabinet top and top edge of front panel (approximately three inches in from side). See Figure 5-19.
- Push in on putty knife and at the same time pull top edge of front panel away from front of washer. Repeat for opposite side.
- Lift front panel off two screws and set panel aside.
- Remove two cabinet top hold-down screws. See Figure 5-24.
- If area or space permits, tape loading door closed and lift cabinet top to a vertical position by hinging it on the rear hinges.

NOTE: Cabinet top is self supporting, however, a small chain may be used for additional support. See Figure 5-25.

- Remove screw holding door switch assembly to underside of cabinet top. See Figure 5-27.
- Disconnect wires from door switch.

NOTE: Refer to appropriate wiring diagram when rewiring switch.

- Remove two screws holding switch to switch holder. See Figure 5-27.
- Remove switch from switch holder.

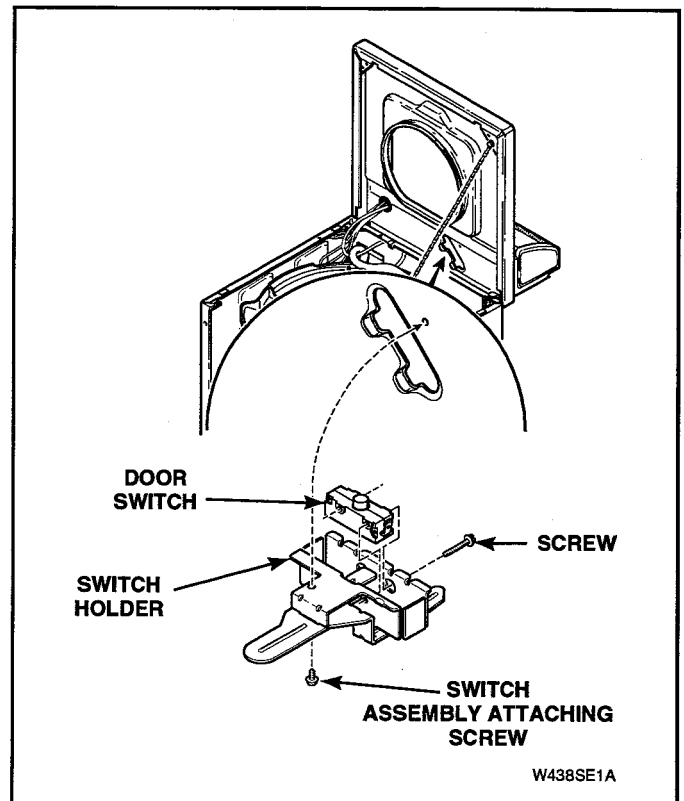

Figure 5-27



WARNING

To reduce the risk of electric shock, fire, explosion, serious injury or death:

- Disconnect electric power to the washer before servicing.
- Never start the washer with any guards/panels removed.
- Whenever ground wires are removed during servicing, these ground wires must be reconnected to ensure that the washer is properly grounded.

W003

17. MIXING VALVE ASSEMBLY

NOTE: Screws located at bottom edge of front panel do not have to be removed as the holes in front panel are slotted.

NOTE: Top edge of front panel is held in place by two spring clips located on bottom flange of cabinet top. See Figure 5-24.

- Insert putty knife between cabinet top and top edge of front panel (approximately three inches in from side). See Figure 5-24.
- Push in on putty knife and at the same time pull top edge of front panel away from front of washer. Repeat for opposite side.
- Lift front panel off two screws and set panel aside.
- Remove two cabinet top hold-down screws. See Figure 5-24.
- If area or space permits, tape loading door closed and lift cabinet top to a vertical position by hinging it on the rear hinges.

NOTE: Cabinet top is self supporting, however, a small chain may be used for additional support. See Figure 5-25.

- Remove two screws holding mixing valve to mounting bracket at rear of washer cabinet. See Figure 5-28.

NOTE: When installing mixing valve, tab on bottom flange must be placed in positioning hole in mounting bracket.

- Pull mixing valve out toward front of washer far enough to permit disconnecting water inlet and fill hoses from mixing valve. See Figure 5-28.
- Remove wires and quick disconnect blocks from mixing valve solenoid terminals. See Figure 5-28.

NOTE: Refer to appropriate wiring diagram when rewiring solenoids.

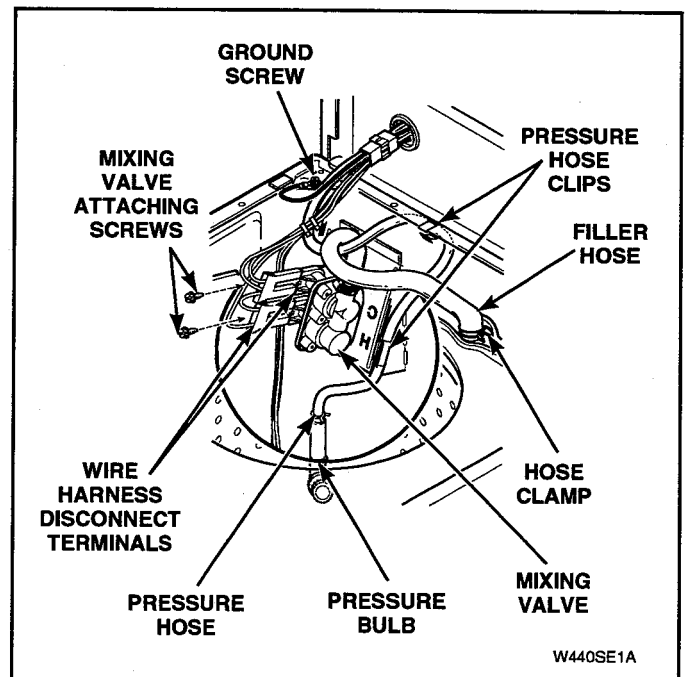
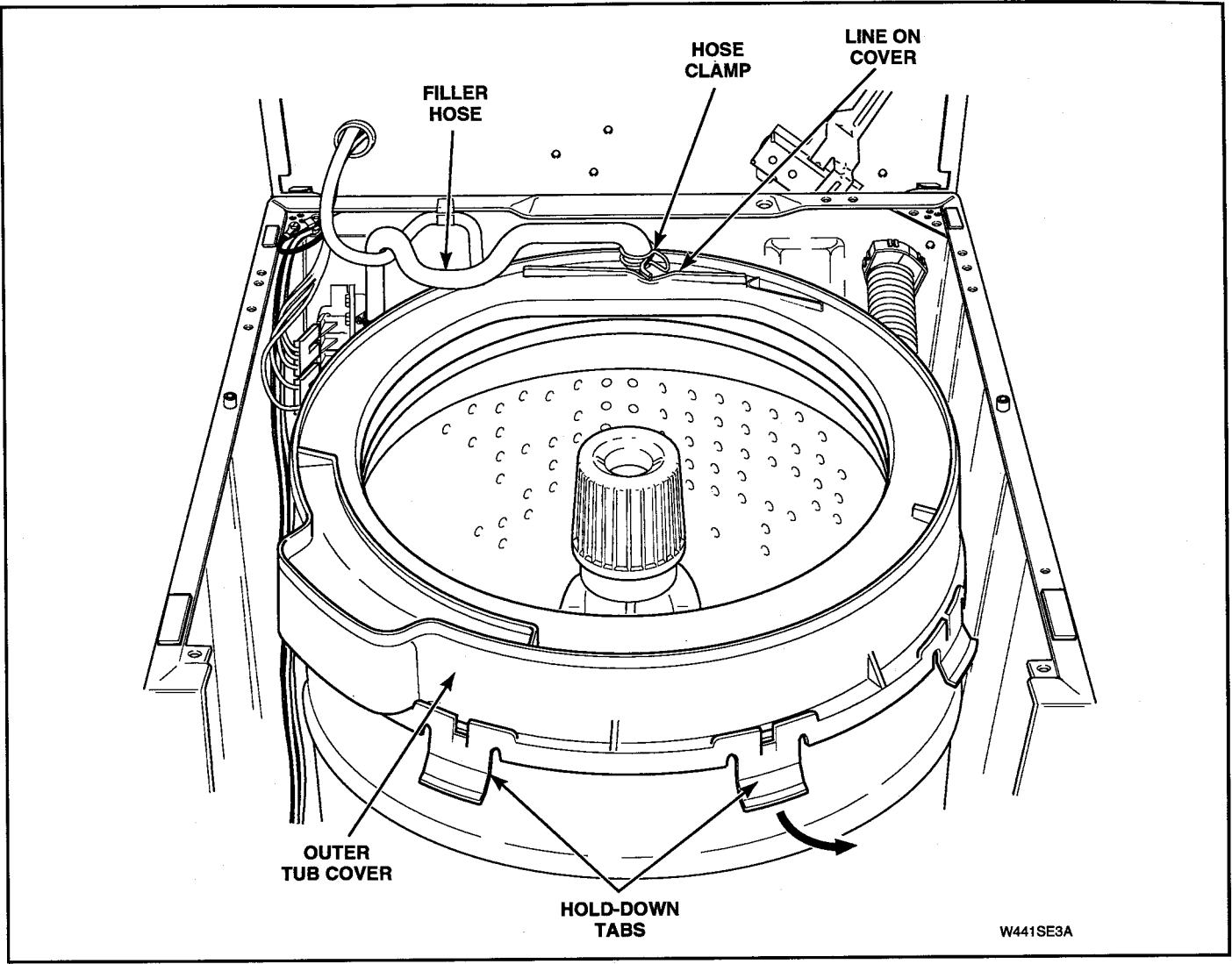

Figure 5-28



W441SE3A

Figure 5-29



WARNING

To reduce the risk of electric shock, fire, explosion, serious injury or death:

- Disconnect electric power to the washer before servicing.
- Never start the washer with any guards/panels removed.
- Whenever ground wires are removed during servicing, these ground wires must be reconnected to ensure that the washer is properly grounded.

W003

18. WASHTUB AND BALANCE RING

- Open loading door.
- Remove agitator by placing two agitator hooks, No. 254P4P, under bottom edge of agitator. See Figure 5-11

IMPORTANT: Hooks should be positioned 180 degrees from each other, and must be placed under agitator vane for greater stability. If hooks are placed between vane area, agitator damage may occur.

- Using a rocking motion (back and forth) carefully lift agitator off drive bell.
- Hinge cabinet top or remove, paragraph 15.
- Loosen hose clamp and remove filler hose from outer tub cover. See Figure 5-29.

NOTE: When installing filler hose, white line on hose must be aligned with line located on top side of outer tub cover. See Figure 5-29.

- There are eight tub cover hold-down tabs which snap over outer tub flange. Place your fingers under the flap of the hold-down tab of the tub cover and pull out on flap and at the same time lift upward on cover to unsnap hold-down tabs from outer tub flange. One by one, disengage each of the eight hold-down tabs from outer tub flange and remove cover.

IMPORTANT: When installing outer tub cover, always use a new cover gasket.

NOTE: Clean and remove any foreign material in gasket groove of outer tub cover and outer tub flange.

- Starting at positioning pin located at the bleach funnel area, lay gasket into gasket groove of tub cover. See Figure 5-30.
- Using your fingers, press gasket down into gasket groove of tub cover. Avoid pressing gasket past ends of hold-down tabs.

IMPORTANT: Care must be taken not to twist or bunch gasket in any one area to avoid leaks after assembly.

- Install gasket past ends of hold-down tabs to bottom of gasket groove using semi-circled end of tool Part No. 273P4. See Figure 5-30.

NOTE: Tub cover gasket tool, Part No. 273P4, is designed to spread open hold-down tabs to prevent tearing of gasket during installation.

- With tub cover tilted at approximately a 45 degree angle, insert the positioning pin into notch on outer tub flange.
- Lower cover and push down firmly on top of hold-down tabs next to positioning pin until tabs snap over edge of outer tub flange.
- Cross over to opposite side of tub cover and push down firmly on top of hold-down tabs until tabs snap over edge of outer tub flange. Continue with this criss-cross pattern, until tub cover is fully seated. Visually check each tab area again to ensure cover is seated.

(continued on Page 30)

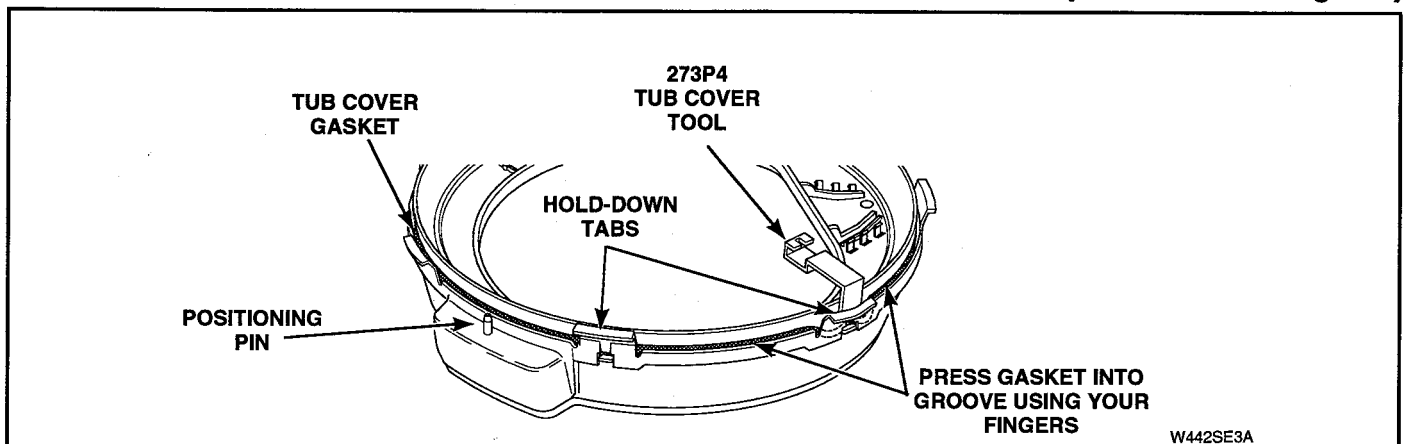

W442SE3A

Figure 5-30

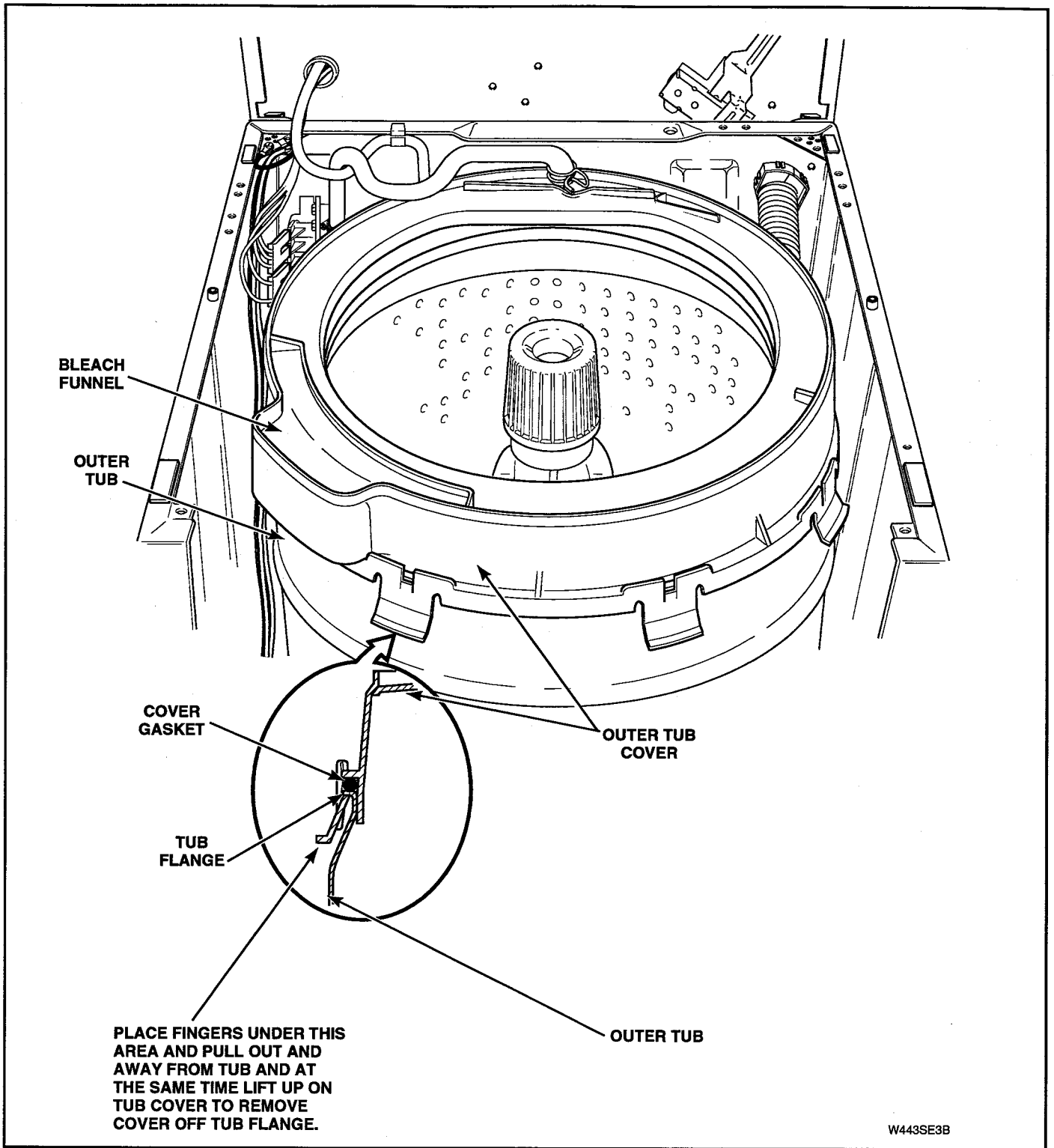

Figure 5-31



WARNING

To reduce the risk of electric shock, fire, explosion, serious injury or death:

- Disconnect electric power to the washer before servicing.
- Never start the washer with any guards/panels removed.
- Whenever ground wires are removed during servicing, these ground wires must be reconnected to ensure that the washer is properly grounded.

W003

m. Remove screws and washers holding washtub to hub. See Figure 5-32.

IMPORTANT: Porcelain Washtub Models — Use care when tightening screws to avoid chipping porcelain on washtub.

n. Lift washtub and balance ring out of outer tub.

IMPORTANT: When removing washtub and balance ring, DO NOT lift up on balance ring as you could damage it. Grasp top flange of washtub and remove from outer tub.

NOTE: When installing washtub, make sure lint filter is between underside of washtub and hub. Some models are equipped with a gasket. On these models, make sure all traces of old gasket are removed from bottom of washtub. When installing washtub in these models, always use a new gasket between washtub and hub.

TO REMOVE BALANCE RING FROM WASHTUB

- Place blade of a small screwdriver into slots between balance ring and washtub. See Figure 5-28.
- Carefully pry pins of balance ring out of holes in washtub. See Figure 5-28.

NOTE: As you are prying out pins, lift up on balance ring.

- Pry pins out of washtub holes approximately half way around tub before balance ring can be removed.

TO INSTALL BALANCE RING IN WASHTUB

Place balance ring on top of washtub, making sure balance ring pins line up with holes in washtub. Then carefully push balance ring down into washtub until all pins snap into their respective holes.

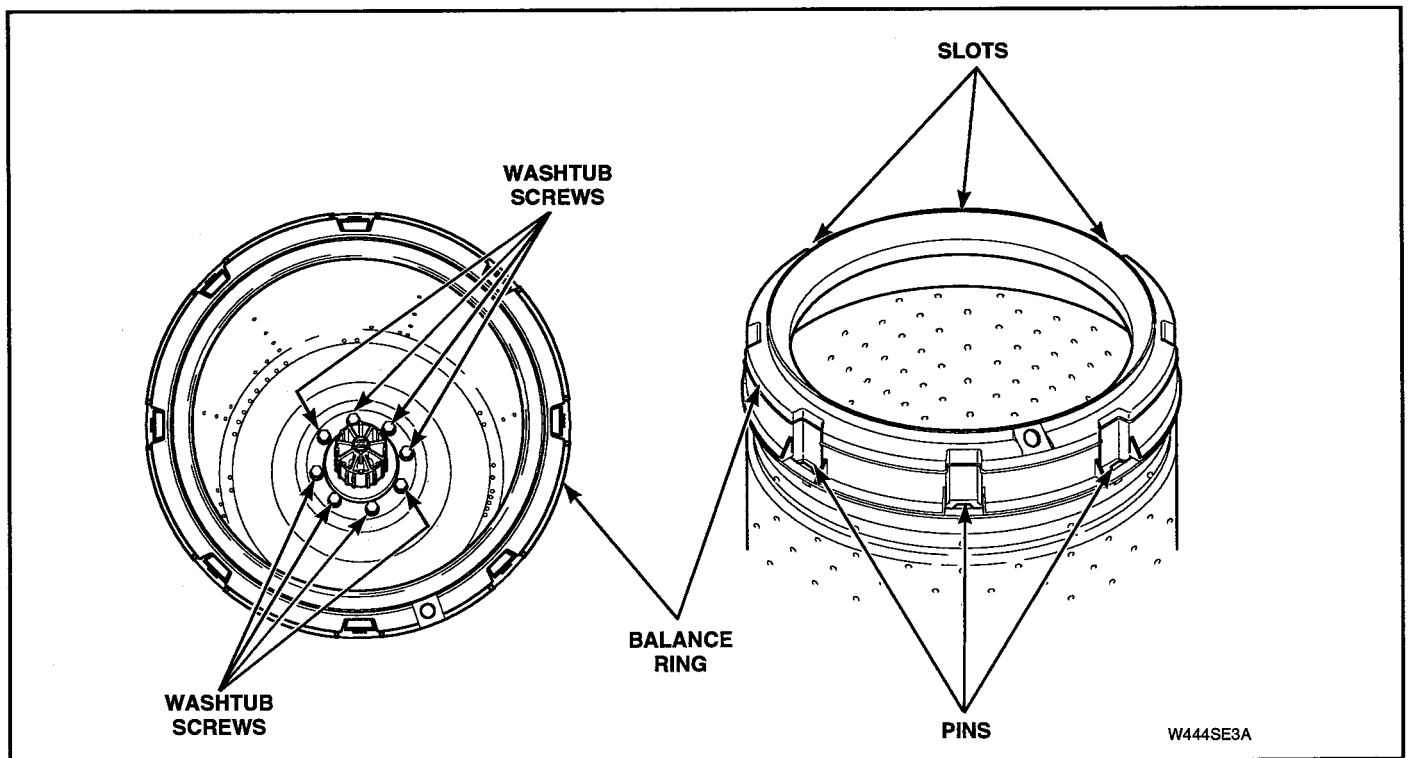

Figure 5-32



WARNING

To reduce the risk of electric shock, fire, explosion, serious injury or death:

- Disconnect electric power to the washer before servicing.
- Never start the washer with any guards/panels removed.
- Whenever ground wires are removed during servicing, these ground wires must be reconnected to ensure that the washer is properly grounded.

W003

19. HUB AND SEAL KIT ASSEMBLY

IMPORTANT: If water is present in washtub, spin and pump out before removing drive bell.

NOTE: Screws located at bottom edge of front panel do not have to be removed as the holes in front panel are slotted.

NOTE: Top edge of front panel is held in place by two spring clips located on bottom flange of cabinet top. See Figure 5-24.

- a. Insert putty knife between cabinet top and top edge of front panel (approximately three inches in from side). See Figure 5-24.
- b. Push in on putty knife and at the same time pull top edge of front panel away from front of washer. Repeat for opposite side.
- c. Lift front panel off two screws and set panel aside.
- d. Open loading door.
- e. Remove agitator by placing two agitator hooks, No. 254P4P, under bottom edge of agitator. See Figure 5-11.

IMPORTANT: Hooks should be positioned 180 degrees from each other, and must be placed under agitator vanes for greater stability. If hooks are placed between vane area, damage to agitator may occur.

- f. Using a rocking motion (back and forth) carefully lift agitator off drive bell.
- g. Hinge cabinet top or remove, paragraph 15.
- h. Loosen hose clamp and remove filler hose from outer tub cover. See Figure 5-29.

NOTE: When reinstalling filler hose, white line on hose must be aligned with line located on top side of outer tub cover. See Figure 5-29.

TUB COVER AND GASKET

1. There are eight tub cover hold-down tabs which snap over the outer tub flange. Place your fingers under the flap of the hold-down tab of the tub cover. Pull out on flap and at the same time lift upward on cover to unsnap hold-down tabs from outer tub flange. One by one, disengage each of the eight hold-down tabs from outer tub flange and remove cover.
2. Lift cover off outer tub and set beside washer cabinet.

IMPORTANT: When installing outer tub cover, always use a new cover gasket.

NOTE: Clean and remove any foreign material in gasket groove of outer tub cover and outer tub flange.

3. Starting at the positioning pin located at the bleach funnel area, lay gasket into gasket groove of tub cover. See Figure 5-30.
4. Using your fingers, press gasket down into gasket groove of tub cover. Avoid pressing gasket past ends of hold-down tabs.

IMPORTANT: Care must be taken not to twist or bunch gasket in any one area to avoid leaks after assembly.

5. Install gasket past ends of hold-down tabs to bottom of gasket groove using semi-curved end of tub cover gasket tool Part No. 273P4.

NOTE: Tub cover gasket tool, Part No. 273P4, is designed to spread open hold-down tabs to prevent tearing of gasket during installation.



WARNING

To reduce the risk of electric shock, fire, explosion, serious injury or death:

- Disconnect electric power to the washer before servicing.
- Never start the washer with any guards/panels removed.
- Whenever ground wires are removed during servicing, these ground wires must be reconnected to ensure that the washer is properly grounded.

W003

6. With tub cover tilted at approximately 45 degree angle, insert the positioning pin into notch on outer tub flange.
 7. Lower cover and push down firmly on top of hold-down tabs next to positioning pin until tabs snap over edge of outer tub flange.
 8. Cross over to opposite side of tub cover and push down firmly on top of hold-down tabs until tabs snap over edge of outer tub flange. Continue with this criss-cross pattern, until tub cover is fully seated. Visually check each tab area again to ensure cover is seated.
- i. Remove screws holding washtub to hub. See Figure 5-32. Then lift washtub out of outer tub.

IMPORTANT: When removing washtub, **DO NOT** lift up on balance ring as you could damage it. Grasp top flange of washtub and remove from outer tub.

NOTE: When installing washtub, make sure lint filter is between underside of washtub and hub.

TO REMOVE AGITATOR DRIVE BELL

- a. Remove plug, screw and "O" ring from top side of drive bell.

NOTE: No 294P4 Drive Bell Tool may be required to remove drive bell from transmission shaft, if not, proceed to step i.

- b. Back bolt out of tool approximately three quarters of the way.
- c. Place tool over bell, making sure indent on jaw lines up with the wide slots on bell. See Figure 5-13.
- d. Screw bolt down through hole in top of bell until bolt bottoms out in hole in transmission shaft.
- e. Place lip of each jaw under bottom edge of drive bell, making sure indent on jaw lines up with wide slots on bell. Then tighten two wing nuts to hold jaws firmly against drive bell. See Figure 5-13.
- f. Use an adjustable wrench and turn large nut on tool **COUNTERCLOCKWISE** to pull drive bell from transmission shaft. See Figure 5-14.

IMPORTANT: If large nut is turned clockwise when pulling drive bell, you will twist off quarter inch bolt.

- g. Turn quarter inch bolt out of transmission shaft, and remove tool and drive bell from washer.
- h. Loosen two wing nuts and remove drive bell from tool.
- i. Remove old seal from hub by placing a flat blade screwdriver between bottom edge of seal and hub using washtub bolts as a pry area to pop off lower seal bead. Then grasp seal and pull straight up freeing the upper seal bead.
- j. Remove large hex nut using a No. 306P4 Hex Wrench. See Figure 5-33.
- k. Remove spline insert from transmission tube.

IMPORTANT: Use a new spline insert each time hex nut is removed. **DO NOT** reuse old insert because hex nut may loosen during washer operation.

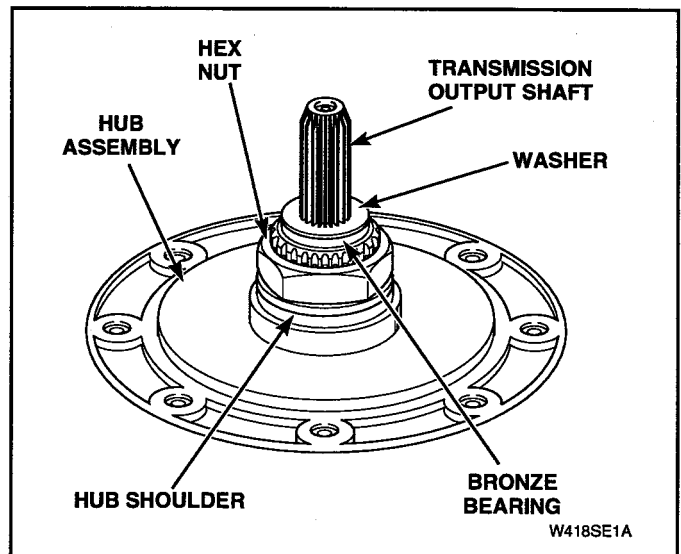

Figure 5-33

- l. Remove hub from splines on transmission tube.

NOTE: It may be necessary to use a gear puller to remove hub.

- m. Remove old water seal from outer tub.

IMPORTANT: Use care when removing old seal so as not to damage tub flange or porcelain.



WARNING

To reduce the risk of electric shock, fire, explosion, serious injury or death:

- Disconnect electric power to the washer before servicing.
- Never start the washer with any guards/panels removed.
- Whenever ground wires are removed during servicing, these ground wires must be reconnected to ensure that the washer is properly grounded.

W003

INSTALLING NO. 646P3 HUB AND SEAL KIT

- a. Thoroughly clean all foreign material from inner surface of outer tub flange.

IMPORTANT: All foreign material must be removed from inner surface of outer tub flange before installing No. 646P3 Hub and Seal Kit.

- b. Apply a small amount of No. 27615P Sealant (3M800) (obtain from local Parts Distributor) around outer surface of tub flange. See Figure 5-35.
- c. Apply a light film of nonstaining petroleum jelly (such as Vaseline®) to bronze portion of water seal and to outer surface of stainless steel sleeve. See Figure 5-35.

IMPORTANT: DO NOT over lubricate!

- d. Insert stainless steel sleeve into water seal from bottom of water seal. See Figure 5-35, until stainless steel sleeve is flush with bronze portion of water seal.
- e. Leaving garter spring on water seal, place new water seal over outer tub flange (with seal lip on outside of tub flange). Then press seal into tub flange opening using moderate finger pressure.
- f. Carefully apply a small amount of No. 27615P Sealant (3M800) (obtain from local Parts Distributor) around outer edge of water seal and tub (area located just below garter spring). See Figure 5-35.

IMPORTANT: DO NOT allow sealant to contact sealing surface of water seal because it will cause a water leak.

- g. Lubricate inner splines of new hub assembly (supplied in kit) with No. 27604P Anti-Seize Compound.
- h. Carefully place new hub assembly on splined transmission tube.

IMPORTANT: Firmly push hub assembly down against outer tub seal and hold in this position during the next three steps.

- i. While holding down hub assembly, place new spline insert (with fingers pointing upward) over transmission tube until it bottoms out on hub assembly.

- j. Place large hex nut over transmission tube (with larger inside bevel toward spline insert) then finger tighten large hex nut.
- k. Torque large hex nut between 40 to 70 foot-pounds (5.56 to 13.21 Kg_m).

NOTE: If torque wrench is not available, place No. 306P4 Hex Wrench over large hex nut then tap hex wrench with a hammer until hub assembly turns or until large hex nut will no longer tighten.

NOTE: If a lint filter was originally installed between washtub and hub assembly, then it must be reinstalled before installing washtub in washer. Proceed to step m.

NOTE: If a gasket was originally installed between washtub and hub assembly, then No. 39122 Gasket (supplied in kit) must be installed before installing washtub in washer. Proceed to step l.

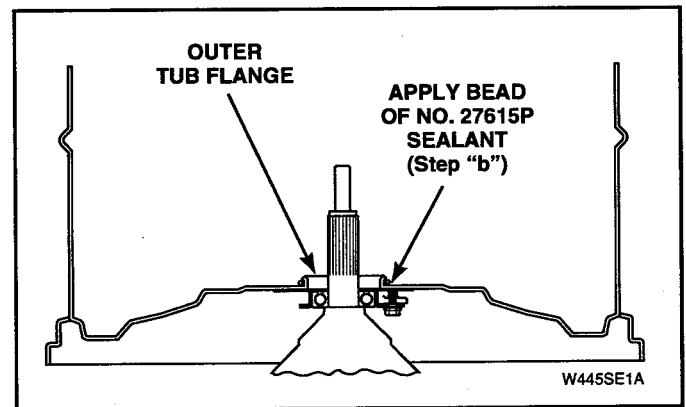

Figure 5-34



WARNING

To reduce the risk of electric shock, fire, explosion, serious injury or death:

- Disconnect electric power to the washer before servicing.
- Never start the washer with any guards/panels removed.
- Whenever ground wires are removed during servicing, these ground wires must be reconnected to ensure that the washer is properly grounded.

W003

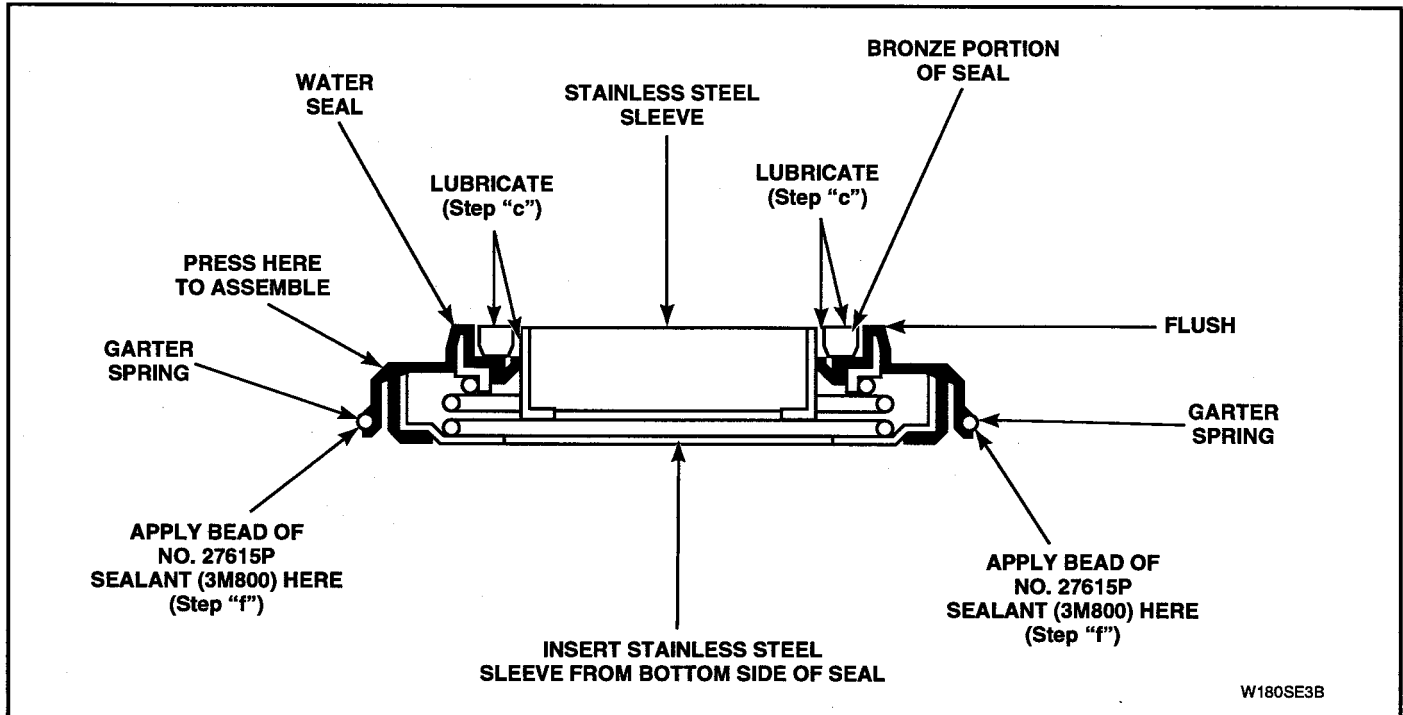

Figure 5-35

- To install No. 39122 Gasket, follow these steps:
 1. Thoroughly clean all foreign material from seal surface area of hub and bronze bearing.
 2. Apply a small amount of nonstaining petroleum jelly (such as Vaseline®) to both surfaces where gasket will contact hub assembly and bottom of washtub.
 3. Carefully place No. 39122 Gasket (supplied in kit) on hub assembly.

NOTE: Ensure holes in gasket are aligned with holes in hub assembly and all traces of original washtub gasket are removed from bottom of washtub.

- m. Grasp top flange of washtub and carefully lower washtub down onto lint filter (or gasket) and hub assembly.

IMPORTANT: Before setting washtub into place, make sure holes in hub assembly are aligned with holes in lint filter (or gasket).

- n. Secure washtub to hub assembly, using cap screws and gaskets from 27202P Screw and Gasket Kit (supplied in kit).

IMPORTANT: Porcelain Washtub Models — Use care when tightening cap screws to avoid chipping or damaging porcelain finish.

- o. Install No. 38359 Outer Tub Cover Gasket (supplied in kit) into outer tub cover, paragraph 18.

IMPORTANT: When installing outer tub cover always use a new outer tub cover gasket.

- p. Reassemble washtub, paragraph 18.
- q. Install seal, drive bell and agitator following the instructions supplied in No. 36443P Drive Bell and Seal Kit.
- r. Reinstall cabinet top and front panel.
- s. Close loading door, set washer timer to final spin, start washer and allow empty washtub to spin for 30 to 60 seconds.

IMPORTANT: Setting washer to spin allows petroleum jelly (applied to bronze portion of water seal) a chance to cover seal surface before water is added to washer.



WARNING

To reduce the risk of electric shock, fire, explosion, serious injury or death:

- Disconnect electric power to the washer before servicing.
- Never start the washer with any guards/panels removed.
- Whenever ground wires are removed during servicing, these ground wires must be reconnected to ensure that the washer is properly grounded.

W003

TUB COVER AND GASKET

NOTE: When installing outer tub cover, always use a new cover gasket.

NOTE: Clean and remove any foreign material in gasket groove of outer tub cover and outer tub flange.

- a. Starting at the positioning pin located at the bleach funnel area, lay gasket into gasket groove of tub cover. See Figure 5-30.
- b. Using your fingers, press gasket down into gasket groove of tub cover. Avoid pressing gasket past ends of hold-down tabs.

IMPORTANT: Care must be taken not to twist or bunch gasket in any one area to avoid leaks after assembly.

- c. Install gasket past ends of hold-down tabs to bottom of gasket groove using semi-curved end gasket tool Part No. 273P4. See Figure 5-32.

NOTE: Tub cover gasket tool, Part No. 273P4, is designed to spread open hold-down tabs to prevent tearing of gasket during installation.

- d. With tub cover tilted at approximately 45 degree angle, insert positioning pin into notch on outer tub flange.
- e. Lower cover and push down firmly on top of hold-down tabs next to positioning pin until tabs snap over edge of outer tub flange.
- f. Cross over to opposite side of tub cover and push down firmly on top of hold-down tabs until tabs snap over edge of outer tub flange. Continue with this criss-cross pattern, until tub cover is fully seated. Visually check each tab area again to ensure cover is seated.
- g. Reinstall filler hose on outer tub cover.

NOTE: When reinstalling filler hose, the white line on hose that connects to tub cover must be aligned with line located on top side of outer tub cover.

See Figure 5-29.

- h. Place agitator on top of drive bell. Slowly rotate agitator until fingers on underside of agitator line up with large slots on drive bell.
- i. A sharp blow on top of agitator, with palm of your hand, will force agitator down onto drive bell, allowing fingers on underside of agitator to lock under bottom edge of drive bell.

NOTE: Do not push agitator onto drive bell any further than necessary.

- j. Reinstall cabinet top and secure to washer cabinet using screws previously removed.
- k. Reinstall front panel.



WARNING

To reduce the risk of electric shock, fire, explosion, serious injury or death:

- Disconnect electric power to the washer before servicing.
- Never start the washer with any guards/panels removed.
- Whenever ground wires are removed during servicing, these ground wires must be reconnected to ensure that the washer is properly grounded.

W003

20. OUTER TUB

- a. Open loading door.
- b. Remove agitator by placing two agitator hooks, No. 254P4P, under bottom edge of agitator. See Figure 5-11.

IMPORTANT: Hooks should be positioned 180 degrees from each other, and must be placed under agitator vane for greater stability. If hooks are placed between vane area, agitator damage may occur.

- c. Using a rocking motion (back and forth) carefully lift agitator off drive bell.

NOTE: Screws located at bottom of front panel do not have to be removed as the holes in front panel are slotted.

NOTE: Top edge of front panel is held in place by two spring clips located on bottom flange of cabinet top. See Figure 5-16.

- d. Insert putty knife between cabinet top and top edge of front panel (approximately three inches in from side). See Figure 5-24.
- e. Push in on putty knife and at the same time pull top edge of front panel away from front of washer. Repeat for opposite side.
- f. Lift front panel off two screws and set panel aside.
- g. Hinge cabinet top or remove, paragraph 15.
- h. Loosen hose clamp, and disconnect filler hose from outer tub cover. See Figure 5-29.

NOTE: When reinstalling filler hose, the white line on hose that connects to tub cover must be aligned with line located on top side of outer tub cover. See Figure 5-29.

TUB COVER AND GASKET

1. There are eight tub cover hold-down tabs which snap over the outer tub flange. Place your fingers under the flaps of the hold-down tab of the tub cover. Pull out on the flap and at the same time lift upward on cover to unsnap hold-down tabs from outer tub flange. One by one, disengage each of the eight hold-down tabs from outer tub flange and remove cover.
2. Remove cover from outer tub and remove old gasket from tub cover.

NOTE: When installing outer tub cover, always use a new cover gasket.

NOTE: Clean and remove any foreign material in gasket groove of outer tub cover and outer tub flange.

3. Starting at positioning pin located at the bleach funnel area, lay gasket into gasket groove of tub cover. See Figure 5-30.
4. Using your fingers, press gasket down into gasket groove of tub cover. Avoid pressing gasket past ends of hold-down tabs.

IMPORTANT: Care must be taken not to twist or bunch gasket in any one area to avoid leaks after assembly.

5. Install gasket past ends of hold-down tabs to bottom of gasket groove using semi-curved end of tub cover gasket tool Part No. 273P4.

NOTE: Tub cover gasket tool, Part No. 273P4, is designed to spread open hold-down tabs to prevent tearing of gasket during installation.

6. With tub cover tilted at approximately a 45 degree angle, insert the positioning pin into notch on outer tub flange.
7. Lower cover and push down firmly on top of hold-down tabs next to positioning pin until tabs snap over edge of outer tub flange.
8. Cross over to opposite side of tub cover and push down firmly on top of hold-down tabs until tabs snap over edge of outer tub flange. Continue with this criss-cross pattern, until tub cover is fully seated. Visually check each tab area again to ensure cover is seated.



WARNING

To reduce the risk of electric shock, fire, explosion, serious injury or death:

- Disconnect electric power to the washer before servicing.
- Never start the washer with any guards/panels removed.
- Whenever ground wires are removed during servicing, these ground wires must be reconnected to ensure that the washer is properly grounded.

W003

- i. Remove screws and washers holding washtub to hub. See Figure 5-32.

IMPORTANT: Porcelain Washtub Models — Use care when tightening cap screws to avoid chipping porcelain on washtub.

- j. Lift washtub (with balance ring attached) out of outer tub.

IMPORTANT: When removing washtub and balance ring, DO NOT lift up on balance ring as you could damage it. Grasp top flange of washtub and remove from outer tub.

- k. Remove agitator drive bell, paragraph 9.
- l. Remove large hex nut using No. 306P4 Hex Wrench. Then remove spline insert from transmission tube.

IMPORTANT: Use a new spline insert each time the hex nut is removed. DO NOT reuse the old insert as hex nut may loosen during the washer operation.

- m. Remove hub from splines on transmission tube.

NOTE: It may be necessary to use a gear puller to remove hub.

- n. Remove old water seal from outer tub.

IMPORTANT: Use care when removing old seal so as not to damage tub flange or porcelain.

NOTE: When reinstalling or replacing outer tub, always install a new No. 646P3 Hub and Seal Kit, paragraph 19.

- o. Reach in through front of motor mounting bracket and move idler lever to left to release tension on belt.

IMPORTANT: Use care when releasing idler lever tension. If idler lever spring is overstretched, washer operation will be affected.

- p. While holding idler lever, reach in and around right side of motor and run belt off right side of pulley.

IMPORTANT: When removing or reinstalling complete tub module into washer (with balance ring, transmission, and weldment assembly attached), damage could occur to idler lever if idler spring is left hooked to motor mounting bracket.

With idler spring hooked to motor mounting bracket, idler lever extends out through rear of bracket. When removing or reinstalling complete tub module assembly, idler lever is in the way and can be damaged (bent), or idler pulley could be chipped. A bent idler lever will cause misalignment of idler pulley with drive belt, and a chipped idler pulley will damage belt.

We recommend that before removing or reinstalling the complete tub module assembly, you unhook idler spring and move idler lever out of the way. This will prevent the possibility of idler lever or pulley damage.

- q. Using No. 289P4 Spring Hook Tool, unhook six module springs from lower edge of outer tub. See Figure 5-36.

IMPORTANT: When installing module springs, make sure spring hook is fully seated in hole in tub skirt. Mark the word "FRONT" on front side of outer tub so complete tub module can be reinstalled in same position.



WARNING

To reduce the risk of electric shock, fire, explosion, serious injury or death:

- Disconnect electric power to the washer before servicing.
- Never start the washer with any guards/panels removed.
- Whenever ground wires are removed during servicing, these ground wires must be reconnected to ensure that the washer is properly grounded.

W003

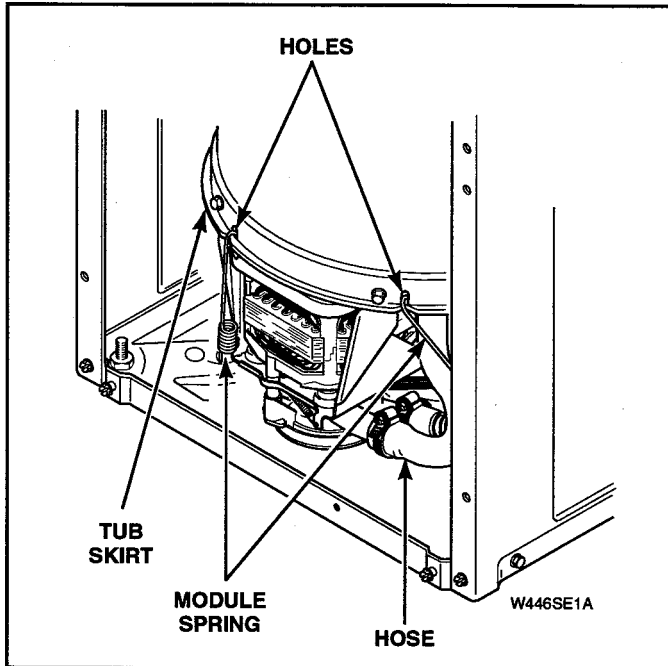

Figure 5-36

NOTE: To prevent porcelain damage, leg plates must be installed on outside of outer tub flange when reinstalling support legs of weldment assembly. Do not overtighten screws as this could cause stripping or porcelain damage. Torque screws between 90 to 130 inch-pounds (10.30 to 14.87 N-m).

w. Turn outer tub upright and remove pressure bulb and grommet.

NOTE: When installing grommet into outer tub, thicker lip of grommet must be installed to outside of tub. Lubricate outer surface of large opening of pressure bulb with liquid soap to aid when assembling pressure bulb into grommet.

- r. Loosen hose clamp and remove hose from bottom of outer tub.
- s. Loosen hose clamp and remove pressure hose from pressure bulb.
- t. Grasp outer tub and lift complete tub module assembly straight up and out of washer cabinet.
- u. Turn outer tub upside-down and set on protective padding.
- v. Remove screws and lockwashers holding counterweight and each support leg to outer tub. See Figure 5-37. Then lift transmission, weldment assembly and counterweight off tub.



WARNING

To reduce the risk of electric shock, fire, explosion, serious injury or death:

- Disconnect electric power to the washer before servicing.
- Never start the washer with any guards/panels removed.
- Whenever ground wires are removed during servicing, these ground wires must be reconnected to ensure that the washer is properly grounded.

W003

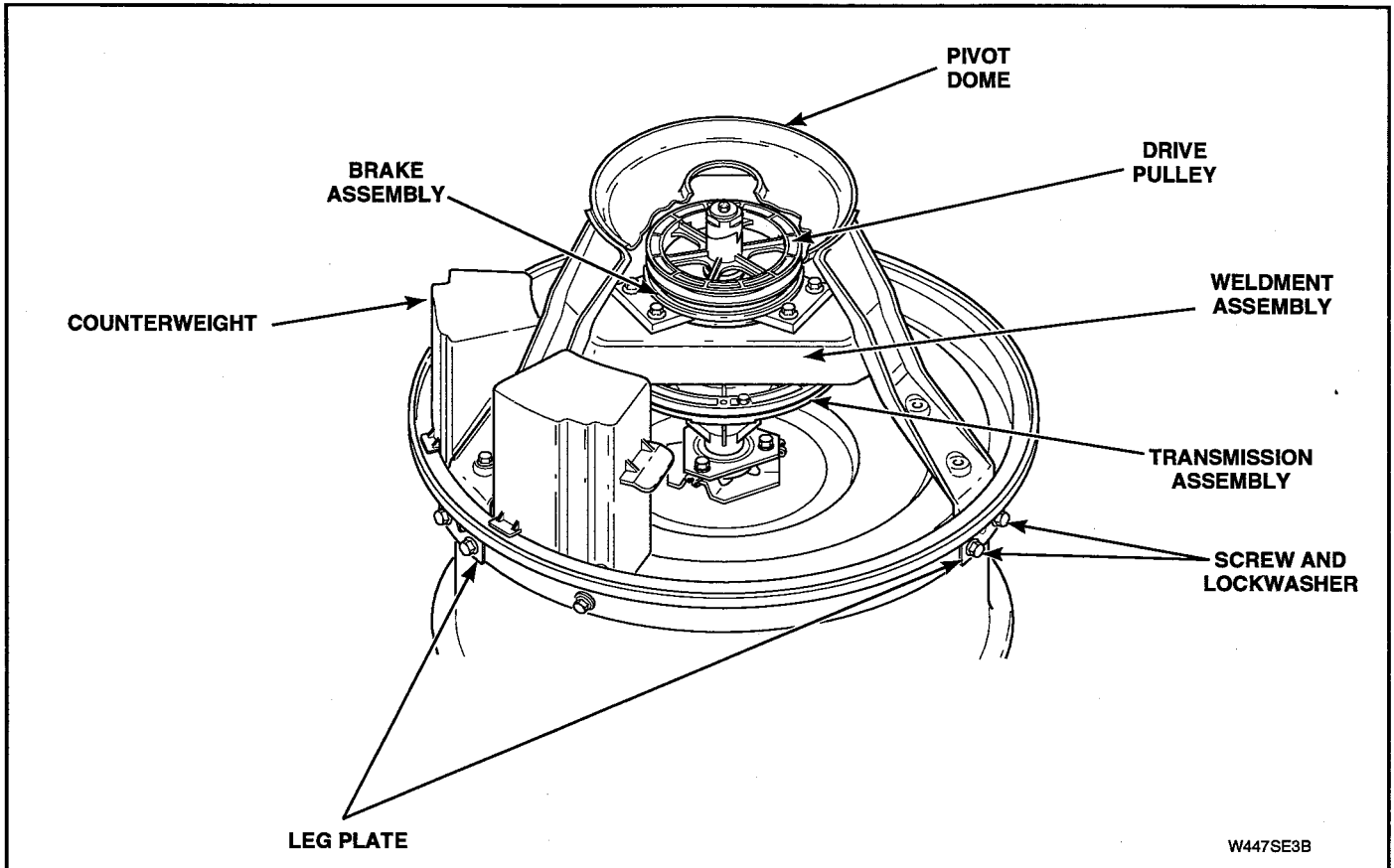

W447SE3B

Figure 5-37

21. DRIVE PULLEY, HELIX AND BRAKE

NOTE: Screws at bottom edge of front panel do not have to be removed as the holes in the front panel are slotted.

NOTE: Top edge of front panel is held in place by two spring clips located on bottom flange of cabinet top. See Figure 5-19.

- Insert putty knife between cabinet top and top edge of front panel (approximately three inches in from side).
- Push in on putty knife and at the same time pull top edge of front panel away from front of washer. Repeat for opposite side.
- Lift front panel off the two screws and set panel aside. See Figure 5-19.
- Hinge cabinet top or remove, paragraph 15.
- Loosen hose clamp and disconnect filler hose from outer tub cover. See Figure 5-29.
- Reach in through front of motor mounting bracket and move idler lever to left to release tension on belt.

NOTE: When reinstalling filler hose, the white line on hose that connects to tub cover must be aligned with line located on top side of outer tub cover. See Figure 5-29.

We recommend that before removing or reinstalling the complete tub module assembly, you unhook idler spring and move idler lever out of the way. This will prevent the possibility of idler lever or pulley damage.

IMPORTANT: Use care when releasing idler lever tension. If idler lever spring is overstretched, washer operation will be affected.



WARNING

To reduce the risk of electric shock, fire, explosion, serious injury or death:

- Disconnect electric power to the washer before servicing.
- Never start the washer with any guards/panels removed.
- Whenever ground wires are removed during servicing, these ground wires must be reconnected to ensure that the washer is properly grounded.

W003

- g. While holding idler lever, reach in and around right side of motor and run belt off right side of pulley.

IMPORTANT: When removing or reinstalling complete tub module into washer (with transmission, and weldment assembly attached), damage could occur to idler lever idler spring if left hooked to motor mounting bracket.

With idler spring hooked to motor mounting bracket, idler lever extends out through rear of bracket. When removing or reinstalling complete tub assembly, idler lever is in the way and can be damaged (bent), or idler pulley could be chipped. A bent idler lever will cause misalignment of idler pulley with drive belt, and a chipped idler pulley will damage belt.

- h. Using No. 289P4 Spring Hook Tool, unhook six module springs from lower edge of outer tub. See Figure 5-36.

IMPORTANT: When installing module springs, make sure spring hook is fully seated in hole in tub skirt. Mark the word "FRONT" on the front side of the outer tub so complete tub module can be reinstalled in the same position.

- i. Loosen hose clamp and remove hose from bottom of outer tub.
- j. Loosen hose clamp and remove pressure hose from pressure bulb.

- k. Grasp outer tub and lift complete tub module assembly (with transmission and weldment assembly attached) straight up and out of washer cabinet.

- l. Turn complete tub module upside-down and set on protective padding.

- m. Remove screw, washer and helix holding drive pulley to input shaft and transmission assembly. See Figure 5-38.

IMPORTANT: On tall tub models, the weldment assembly must be removed or loosened and raised enough to get pulley off and on the input shaft.

- n. Lift drive pulley up and off input shaft of transmission assembly.

NOTE: When reinstalling pulley, place a small amount of No. 03200P Lubricant on top side of the drive pulley that will be contacting large flat washers. See Figure 5-38 for assembly sequence. Lubricate helix ramps and bore with a small amount of No. 03200P Lubricant. See Figure 5-39.

IMPORTANT: DO NOT OVER LUBRICATE! Excess lubricant can be thrown into pivot dome area during normal washer operation. Any lubricant on pivot dome, base or friction ring will affect washer operation. This condition will persist until lubricant is removed.

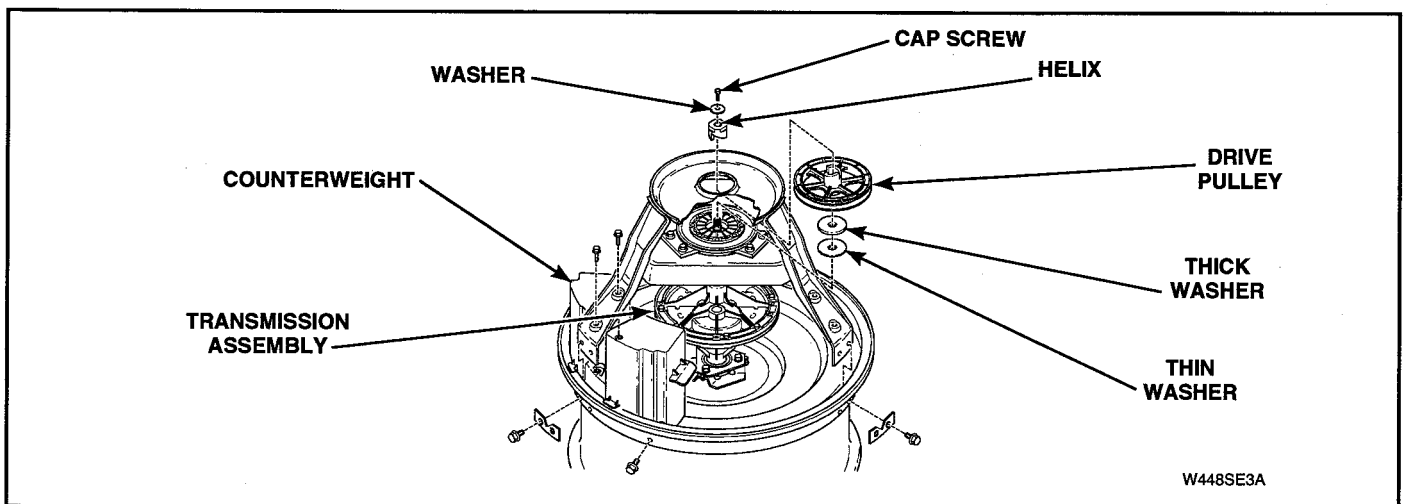

Figure 5-38

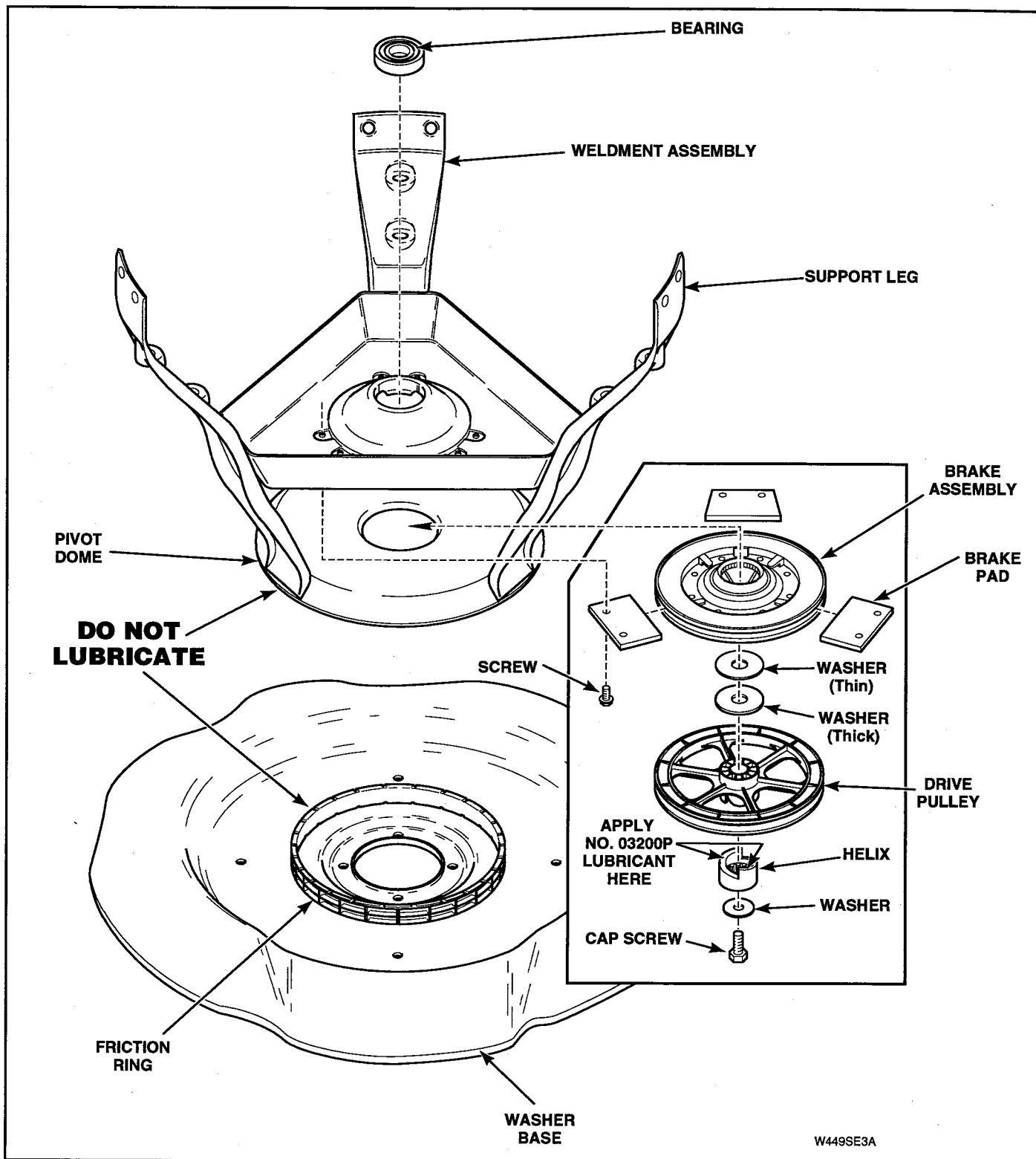

Figure 5-39



WARNING

To reduce the risk of electric shock, fire, explosion, serious injury or death:

- Disconnect electric power to the washer before servicing.
- Never start the washer with any guards/panels removed.
- Whenever ground wires are removed during servicing, these ground wires must be reconnected to ensure that the washer is properly grounded.

W003

- o. Remove screws holding three brake pads and brake assembly to weldment assembly. See Figure 5-39. Then remove brake assembly and pads off bottom of weldment assembly.

IMPORTANT: When reinstalling brake assembly, we recommend replacing three brake pads. **DO NOT** replace worn pads only. Apply a small amount of No. 26594P Silicone Lubricant to both sides of each brake pad where it will contact brake assembly.

IMPORTANT: DO NOT OVER LUBRICATE! Excess lubricant can be thrown into pivot dome area during normal washer operation. Any lubricant on pivot dome, base or friction ring will affect washer operation. This condition will persist until lubricant is removed.

NOTE: Refer to Figure 5-39 for assembly sequence.

- p. After brake is installed, put washer through the following check to make sure brake is operating properly.
 1. Turn off electrical power to washer.
 2. Turn drive pulley one complete revolution in agitation directly, then push drive pulley up against brake.
 3. Check for a .030 (.76 mm) minimum gap between drive pulley and helix ramp surfaces.

IMPORTANT: If gap is less than .030 (.76 mm), brake may not stop washtub from spinning in required seven seconds because brake will not close properly.

4. Turn on electrical power to washer and start washer in the final spin.

IMPORTANT: After installing complete tub module in washer and all hoses have been reconnected, add at least a quart of water to washtub to lubricate pump seals. Running a pump without water will ruin the seals.

NOTE: After washtub has been spinning for two minutes, normal spin speed should be 640 ± 20 RPM one speed models; 640 ± 20 RPM **FAST** speed, or 390 ± 20 RPM **SLOW** speed on two speed models; or 710 ± 20 RPM on **FAST** speed or 473 ± 20 RPM on **SLOW** speed on three speed models. Three speed models never spin on the lowest speeds. If not, the cause could be dragging brake pads. If problems occur with steps three or four, remove brake assembly and correct problem.



WARNING

To reduce the risk of electric shock, fire, explosion, serious injury or death:

- Disconnect electric power to the washer before servicing.
- Never start the washer with any guards/panels removed.
- Whenever ground wires are removed during servicing, these ground wires must be reconnected to ensure that the washer is properly grounded.

W003

22. WELDMENT AND BEARING ASSEMBLY

NOTE: Screws at bottom edge of front panel do not have to be removed as the holes in the front panel are slotted.

NOTE: Top edge of front panel is held in place by two spring clips located on bottom flange of cabinet top. See Figure 5-19.

- a. Insert putty knife between cabinet top and top edge of front panel (approximately three inches in from side).
- b. Push in on putty knife and at the same time pull top edge of front panel away from front of washer. Repeat for opposite side.
- c. Lift front panel off the two screws. See Figure 5-19, and set panel aside.
- d. Hinge cabinet top or remove, paragraph 15.
- e. Loosen hose clamp and disconnect filler hose from outer tub cover. See Figure 5-29.

NOTE: When reinstalling filler hose, the white line on hose that connects to tub cover must be aligned with line located on top side of outer tub cover. See Figure 5-29.

- f. Reach in through front of motor mounting bracket and move idler lever to left to release tension on belt.

We recommend that before removing or reinstalling the complete tub module assembly, you unhook idler spring and move idler lever out of the way. This will prevent the possibility of idler lever or pulley damage.

IMPORTANT: Use care when releasing idler lever tension. If idler lever spring is overstretched, washer operation will be affected.

- g. While holding idler lever, reach in and around right side of motor and run belt off right side of pulley.

IMPORTANT: When removing or reinstalling complete tub module into washer (with transmission, and weldment assembly attached), damage could occur to idler lever idler spring if left hooked to motor mounting bracket.

With idler spring hooked to motor mounting bracket, idler lever extends out through rear of bracket. When removing or reinstalling complete tub assembly, idler lever is in the way and can be damaged (bent), or idler pulley could be chipped. A bent idler lever will cause misalignment of idler pulley with drive belt, and a chipped idler pulley will damage belt.

- h. Using No. 289P4 Spring Hook Tool, unhook six module springs from lower edge of outer tub. See Figure 5-36.

IMPORTANT: When installing module springs, make sure spring hook is fully seated in hole in tub skirt. Mark the word "FRONT" on the front side of the outer tub so complete tub module can be reinstalled in the same position.

- i. Loosen hose clamp and remove hose from bottom of outer tub.
- j. Loosen hose clamp and remove pressure hose from pressure bulb.
- k. Grasp outer tub and lift complete tub module assembly (with transmission and weldment assembly attached) straight up and out of washer cabinet.
- l. Turn complete tub module upside-down and set on protective padding.
- m. Remove screw, washer and helix holding drive pulley to input shaft and transmission assembly. See Figure 5-38.

IMPORTANT: On tall tub models, the weldment assembly must be removed or loosened and raised enough to get pulley off and on the input shaft.



WARNING

To reduce the risk of electric shock, fire, explosion, serious injury or death:

- Disconnect electric power to the washer before servicing.
- Never start the washer with any guards/panels removed.
- Whenever ground wires are removed during servicing, these ground wires must be reconnected to ensure that the washer is properly grounded.

W003

- n. Lift drive pulley up and off input shaft of transmission assembly.

NOTE: When reinstalling pulley, place a small amount of No. 03200P Lubricant on top side of the drive pulley that will be contacting large flat washers. See Figure 5-38 for assembly sequence. Lubricate helix ramps and bore with a small amount of No. 03200P Lubricant. See Figure 5-39.

IMPORTANT: DO NOT OVER LUBRICATE!

Excess lubricant can be thrown into pivot dome area during normal washer operation. Any lubricant on pivot dome, hose or friction ring will affect washer operation. This condition will persist until lubricant is removed.

- o. Remove screws holding three brake pads and brake assembly to weldment assembly. See Figure 5-39. Then remove brake assembly and pads off bottom of weldment assembly.

IMPORTANT: When reinstalling brake assembly, we recommend replacing three brake pads. **DO NOT** replace worn pads only. Apply a small amount of No. 265494P Silicone Lubricant to both sides of each brake pad where it will contact brake assembly.

IMPORTANT: DO NOT OVER LUBRICATE!

Excess lubricant can be thrown into pivot dome area during normal washer operation. Any lubricant on pivot dome, base or friction ring will offset washer operation. This condition will persist until lubricant is removed.

NOTE: Refer to Figure 5-39 for assembly sequence.

- p. After brake is installed, put washer through the following check to make sure brake is operating properly.
1. Turn off electrical power to washer.
 2. Turn drive pulley one complete revolution in agitation direction, then push drive pulley up against brake.
 3. Check for a .030 (.76 mm) minimum gap between drive pulley and helix ramp surfaces.

IMPORTANT: If gap is less than .030 (.76 mm), brake may not stop washtub from spinning in required seven seconds because brake will not close properly.

4. Turn on electrical power to washer and start washer in the final spin.

IMPORTANT: After installing complete tub module in washer and all hoses have been reconnected, add at least a quart of water to washtub to lubricate pump seals. Running a pump without water will ruin the seals.

NOTE: After washtub has been spinning for two minutes, normal spin speed should be 640 ± 20 RPM one speed models; 640 ± 20 RPM **FAST** speed, or 390 ± 20 RPM **SLOW** speed on two speed models; or 710 ± 20 RPM on **FAST** speed or 473 ± 20 RPM on **SLOW** speed on three speed models. Three speed models never spin on the lowest speeds. If not, the cause could be dragging brake pads. If problems occur with steps three or four, remove brake assembly and correct problem.

- q. Remove screws and lockwashers holding counterweight and each support leg to outer tub. See Figure 5-37. Then lift transmission, weldment assembly and counterweight off tub.

NOTE: It may be necessary to tap lightly on the weldment assembly to loosen it from transmission tube.

NOTE: To prevent porcelain damage, leg plates must be installed on outside of outer tub flange when reinstalling support legs of weldment assembly. Do not overtighten screws as this could cause stripping or porcelain damage. Torque screws between 90 to 130 inch-pounds (10.30 to 14.87 N-m).

- r. Remove screws and washers holding counterweight to leg on weldment assembly.



WARNING

To reduce the risk of electric shock, fire, explosion, serious injury or death:

- Disconnect electric power to the washer before servicing.
- Never start the washer with any guards/panels removed.
- Whenever ground wires are removed during servicing, these ground wires must be reconnected to ensure that the washer is properly grounded.

W003

23. TRANSMISSION ASSEMBLY

- a. Open loading door.
- b. Remove agitator by placing two agitator hooks, No. 254P4P, under bottom edge of agitator. See Figure 5-11.

IMPORTANT: Hooks should be positioned 180 degrees from each other, and must be placed under base of agitator near an agitator vane for greater stability. If hooks are placed between vane area, damage to agitator may occur.

- c. Using a rocking motion (back and forth) carefully lift agitator off drive bell.

NOTE: Screws at bottom edge of front panel do not have to be removed as the holes in the front panel are slotted.

NOTE: Top edge of front panel is held in place by two spring clips located on bottom flange of cabinet top. See Figure 5-19.

- d. Insert putty knife between cabinet top and top edge of front panel (approximately three inches in from side).
- e. Push in on putty knife and at the same time pull top edge of front panel away from front of washer. Repeat for opposite side.
- f. Lift front panel off the two screws and set panel aside. See Figure 5-19.
- g. Remove two cabinet top hold-down screws, and hinge cabinet top or remove, paragraph 15.
- h. Loosen hose clamp and disconnect filler hose from outer tub cover. See Figure 5-29.

NOTE: When reinstalling filler hose, the white line or hose that connects to tub cover must be aligned with line located on top side of outer tub cover. See Figure 5-29.

TUB COVER AND GASKET

1. There are eight tub cover hold-down tabs which snap over the outer tub flange. Place your fingers under the flaps of the hold-down tab of the tub cover and pull out on the flap and at the same time lift upward on cover to unsnap hold-down tabs from outer tub flange. One by one, disengage each of the eight hold-down tabs from outer tub flange and remove cover.
2. Remove cover from outer tub and remove old gasket from tub cover.

NOTE: When installing outer tub cover, always use a new cover gasket.

NOTE: Clean and remove any foreign material in gasket groove of outer tub cover and outer tub flange.

3. Starting at positioning pin located at the bleach funnel area, lay gasket into gasket groove of tub cover. See Figure 5-30.
4. Using your fingers, press gasket down into gasket groove of tub cover. Avoid pressing gasket past ends of hold-down tabs.

IMPORTANT: Care must be taken not to twist or bunch gasket in any one area to avoid leaks after assembly.

5. Install gasket past ends of hold-down tabs to bottom of gasket groove using semi-curved end of tub cover gasket tool part No. 273P4.

NOTE: Gasket tool, Part No. 273P4, is designed to spread open hold-down tabs to prevent tearing of gasket during installation.



WARNING

To reduce the risk of electric shock, fire, explosion, serious injury or death:

- Disconnect electric power to the washer before servicing.
- Never start the washer with any guards/panels removed.
- Whenever ground wires are removed during servicing, these ground wires must be reconnected to ensure that the washer is properly grounded.

W003

- i. Remove screws and washers holding washtub to hub. See Figure 5-32.

IMPORTANT: Porcelain Washtub Models — Use care when tightening cap screws to avoid chipping porcelain on washtub.

- j. Lift washtub (with balance ring attached) out of outer tub

IMPORTANT: When removing washtub and balance ring, DO NOT lift up on balance ring as you could damage it. Grasp top flange of washtub and remove from outer tub.

- k. Remove agitator drive bell, paragraph 9.
l. Remove large hex nut using No. 306P4 Hex Wrench. Then remove spline insert from transmission tube.
m. Remove hub from splines on transmission tube.

NOTE: It may be necessary to use a gear puller to remove hub.

- n. Remove old water seal from outer tub.

IMPORTANT: Use care when removing old seal so as not to damage tub flange or porcelain.

NOTE: When reinstalling or replacing outer tub, always install a new No. 646P3 Hub and Seal Kit, paragraph 19. While holding idler lever, reach in and around right side of motor and run belt off right side of pulley.

We recommend that before removing or reinstalling the complete tub module assembly, you unhook idler spring and move idler lever out of the way. This will prevent the possibility of idler lever or pulley damage.

- o. Using No. 289P4 Spring Hook Tool, unhook six module springs from lower edge of outer tub. See Figure 5-36.

IMPORTANT: Mark the word “FRONT” on front side of outer tub so complete tub module can be reinstalled in same position.

- p. Loosen hose clamp and remove hose from bottom of outer tub.

IMPORTANT: Some water will always remain in outer tub. Therefore, before removing hose from pump, pinch off or drain hose to prevent water spillage.

- q. Loosen hose clamp and remove pressure hose from pressure bulb.
r. Grasp outer tub and lift complete tub module assembly straight up and out of washer cabinet.
s. Turn tub module upside-down and set on protective padding. See Figure 5-37.
t. Remove screw, washer and helix holding drive pulley to input shaft of transmission assembly. See Figure 5-38.
u. Lift drive pulley up and out from between support legs.

NOTE: When reinstalling pulley, place a small amount of No. 03200P Lubricant to top side of drive pulley that will be contacting the large flat washer. Lubricate helix ramps with a small amount of No. 03200P Lubricant. See Figure 5-39.

IMPORTANT: DO NOT OVER LUBRICATE! Excess lubricant can be thrown into pivot dome area during normal washer operation. Any lubricant on pivot dome, base or friction ring will offset washer operation. This condition will persist until lubricant is removed.

- v. Remove screws and lockwashers holding each support leg to outer tub. See Figure 5-39. Then lift weldment assembly, and brake assembly off transmission tube.

NOTE: It may be necessary to tap lightly on weldment assembly to loosen it from transmission tube.



WARNING

To reduce the risk of electric shock, fire, explosion, serious injury or death:

- Disconnect electric power to the washer before servicing.
- Never start the washer with any guards/panels removed.
- Whenever ground wires are removed during servicing, these ground wires must be reconnected to ensure that the washer is properly grounded.

W003

NOTE: When installing lower bearing, weldment assembly and brake assembly, apply No. 27604P Anti-Seize Compound to area of transmission tube that will be contacting bearing. See Figure 5-40.

To prevent porcelain damage, leg plates must be installed on outside of outer tub flange when reinstalling support legs of weldment assembly. See Figure 5-37. Do not overtighten screws as this could cause stripping or porcelain damage. Torque screws between 90 to 130 inch-pounds (10.30 to 14.87 N-m).

IMPORTANT: When replacing or reinstalling transmission assembly, it is important that No. 27604P Anti-Seize Compound be applied to area of the transmission tubes where they will be contacting upper and lower bearings. See Figure 5-40.

Carefully lower transmission through upper bearing. **DO NOT DROP OR LOWER TRANSMISSION ASSEMBLY INTO POSITION TOO HARD.** This can cause bearing to move which will cause vibration, noise, wear or no spin.

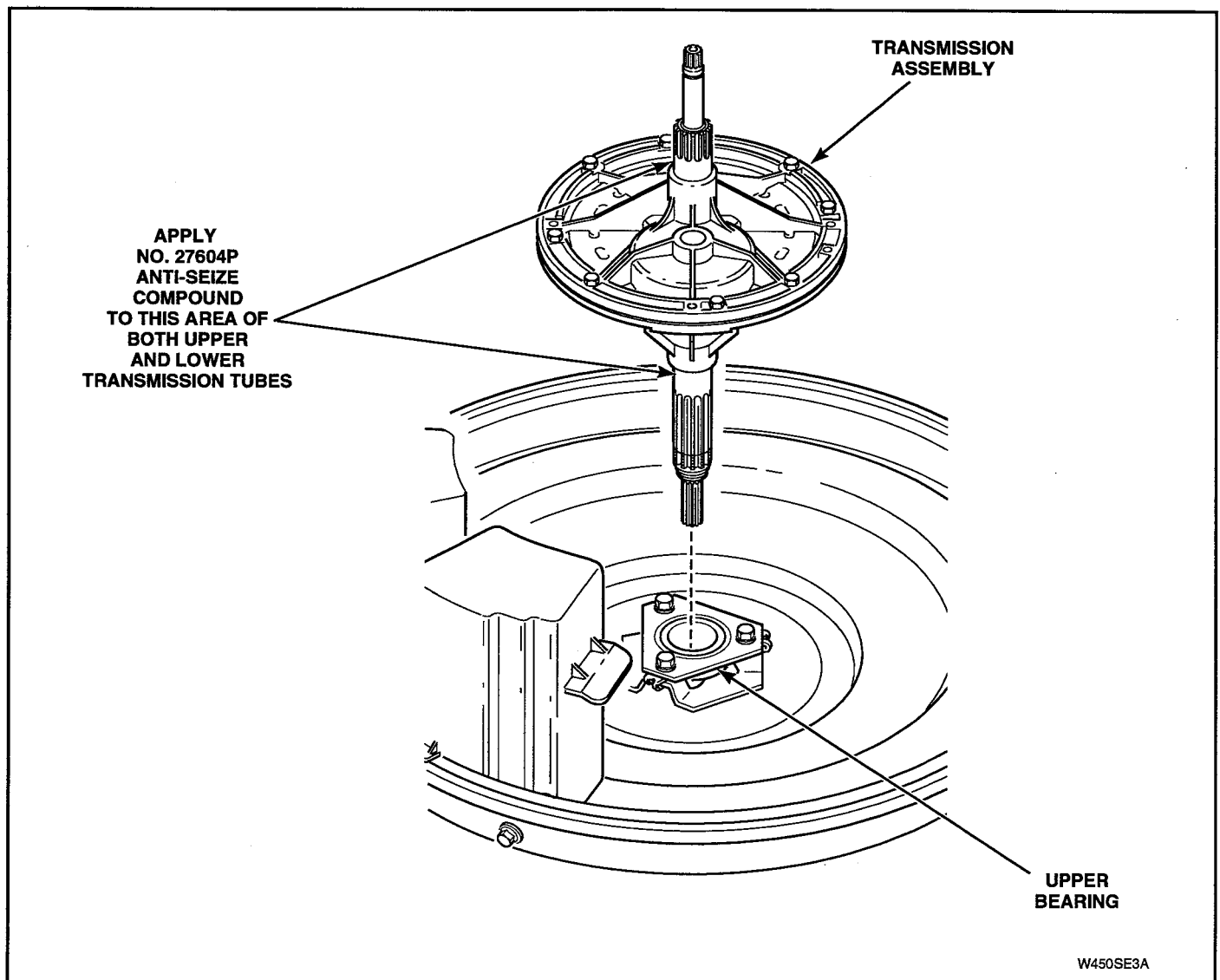

Figure 5-40



WARNING

To reduce the risk of electric shock, fire, explosion, serious injury or death:

- Disconnect electric power to the washer before servicing.
- Never start the washer with any guards/panels removed.
- Whenever ground wires are removed during servicing, these ground wires must be reconnected to ensure that the washer is properly grounded.

W003

TO DISASSEMBLE TRANSMISSION ASSEMBLY (Refer to Figure 5-41 for assembly sequence)

- a. Place transmission in a vise with input shaft end up. Clamp only the case, not the shaft.

NOTE: Supporting transmission in this manner will allow oil to collect in the transmission case.

- b. Before disassembling transmission halves, mark outer edge of transmission case and cover so two can be reassembled in the same position.
- c. Place transmission in vise so three of the eight screws holding transmission case and cover together are in the twelve, four and seven o'clock positions.
- d. Loosen three screws, mentioned in step "c", approximately two turns. **DO NOT** remove these three screws at this time. Remove remaining five screws and lockwashers completely.
- e. Remove transmission assembly from vise.
- f. While holding transmission by cover end, gently tap each of the three remaining screws until two halves separate. Place assembly back into vise (cover end up) and remove three screws and lockwashers.
- g. Remove screw and washer holding reduction gear to transmission cover and remove gear.
- h. Remove special screw, lockwasher and flat washer holding drive pinion to input shaft.

NOTE: To prevent input shaft from turning during removal of special screw, place an old helix onto shaft and hold helix with a locking pliers.

- i. Remove drive pinion from input shaft using a hammer and punch to drive shaft out of pinion.
- j. Remove input shaft from transmission cover.

IMPORTANT: Carefully examine area inside cover tube (seals, bearing, roller clutch, etc.). If oil is present between seals and bearing, or roller clutch is bad, it will require replacing complete transmission cover assembly. These components are not available separately.

- k. Remove internal gear, slide and rack from transmission case.
- l. Remove transmission case from vise and drain oil.
- m. Remove retainer ring from output shaft.

- n. Using a hammer and punch, carefully drive shaft out of agitator pinion.
- o. Carefully remove output shaft and washer from transmission case.

IMPORTANT: Carefully examine area inside transmission case tube (seals, bearings, etc.). If oil is present between seals and bearings, it will require replacing complete transmission case. Seals and bearings are not available separately.



WARNING

To reduce the risk of electric shock, fire, explosion, serious injury or death:

- Disconnect electric power to the washer before servicing.
- Never start the washer with any guards/panels removed.
- Whenever ground wires are removed during servicing, these ground wires must be reconnected to ensure that the washer is properly grounded.

W003

TO REASSEMBLE TRANSMISSION ASSEMBLY

IMPORTANT: Wash all components in a cleaning solution (mineral spirits). Wipe inside of transmission case and cover with a clean cloth, dampened with cleaning solution, to remove any impurities. **DO NOT** allow cleaning solution to come in contact with bearings and seals in transmission case and/or cover.

- a. Carefully insert output shaft and washer into transmission case.
- b. Place agitator pinion on splines of output shaft and press onto shaft.
- c. Install retainer ring on output shaft.
- d. Place transmission case into a vise. Clamp only the case, not the shaft.
- e. Place rack inside transmission case with rack resting on bar in case. Agitator pinion must engage the rack.

NOTE: Put a light film of transmission oil on bar where rack will slide back and forth.

- f. Position slide in slot in rack.

NOTE: Put a light film of transmission oil in slot on rack, and also the transmission case where internal gear will ride.

- g. Place internal gear into transmission case. Make sure guide pin on internal gear fits in hole in slide.

IMPORTANT: Never install a used internal gear in a new transmission case. If transmission case and internal gear are to be reused, be sure they are used as the original set.

- h. Refill transmission case with new No. 27243P Transmission Oil (one fill).
- i. To prevent seal damage, insert input shaft into cover starting at outer end of cover tube.

IMPORTANT: End of shaft with identification groove must be facing outward. See Figure 5-41. This is the end that will mate with the helix.

- j. Install drive pinion, flat washer, lockwasher and special screw onto input shaft.

NOTE: Use a thread locking compound on threads of special screw to prevent screw from loosening on shaft.

IMPORTANT: Make sure mating surfaces of transmission cover and case are free of oil or any other foreign material.

- k. Place reduction gear on stub shaft of cover and install screw and washer.
- l. Apply a bead of No. 37577P Sealant on mating surface of transmission case.

IMPORTANT: Bead of sealant should be no more than one sixteenth inch in diameter. **DO NOT** allow any sealant to contact edges of internal gear (sealant may damage moving parts).

NOTE: A transmission pin tool, Part No. 305P4, must be used to align the cover and case when reassembling the transmission after repair. The transmission pin tool must be used in sets of two and placed in the same holes shown in Figure 5-41. Both transmission pin tools must be left in place until all eight screws and nuts have been installed and tightened firmly, then remove the two pins.

- m. Carefully place transmission cover over top of transmission case. Make sure holes in cover line up with holes in case, and marked edges of two halves are aligned.
- n. Carefully lower cover onto case.
- o. Secure two transmission halves together, using eight screws removed during disassembly. Tighten eight screws evenly.
- p. Remove complete transmission assembly from vise.
- q. Apply Anti-Seize Compound, No. 27604P, to smooth area of both transmission tubes that will be contacting upper and lower bearings. See Figure 5-40.



WARNING

To reduce the risk of electric shock, fire, explosion, serious injury or death:

- Disconnect electric power to the washer before servicing.
- Never start the washer with any guards/panels removed.
- Whenever ground wires are removed during servicing, these ground wires must be reconnected to ensure that the washer is properly grounded.

W003

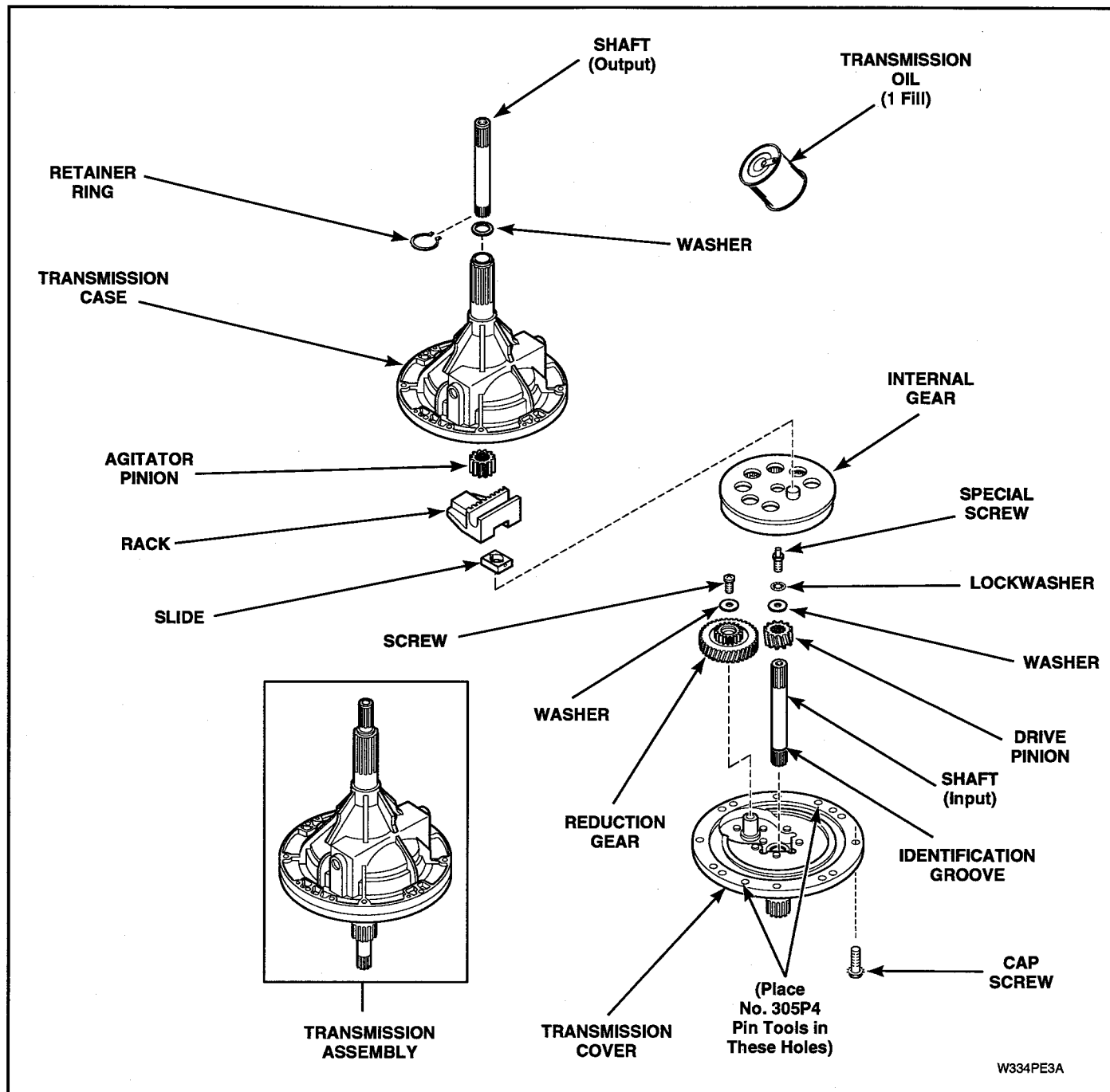

Figure 5-41



WARNING

To reduce the risk of electric shock, fire, explosion, serious injury or death:

- Disconnect electric power to the washer before servicing.
- Never start the washer with any guards/panels removed.
- Whenever ground wires are removed during servicing, these ground wires must be reconnected to ensure that the washer is properly grounded.

W003

24. UPPER BEARING ASSEMBLY

- Remove transmission assembly, paragraph 23, steps "a" through "u".
- Remove screws and lockwashers holding each support leg to outer tub. See Figure 5-37.
- Lift complete weldment assembly (with drive pulley, brake assembly, lower bearing, and transmission assembly attached) off outer tub.

- Remove three screws holding upper bearing and housing to bottom of outer tub. See Figure 5-42.

NOTE: Replace bearing and housing as an assembly.

NOTE: When upper bearing assembly is reinstalled, threads of cap screws must be secured with a retaining compound.

IMPORTANT: To prevent porcelain damage, leg plates must be installed on outer tub flange when reinstalling support legs. (Plate must be installed on outside of tub flange). Do not overtighten screws as this could cause stripping or porcelain damage.

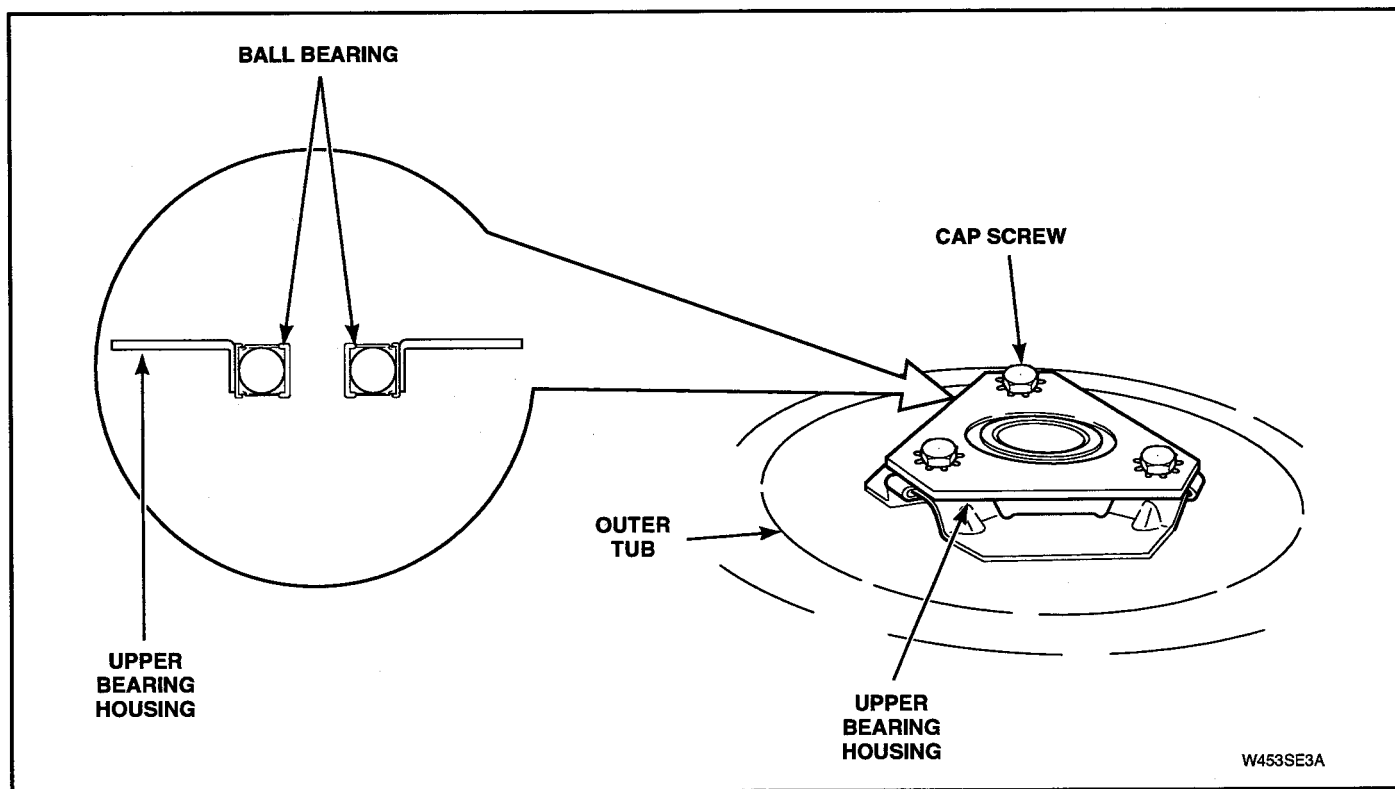

Figure 5-42



WARNING

To reduce the risk of electric shock, fire, explosion, serious injury or death:

- Disconnect electric power to the washer before servicing.
- Never start the washer with any guards/panels removed.
- Whenever ground wires are removed during servicing, these ground wires must be reconnected to ensure that the washer is properly grounded.

W003

25. FRICTION RING

NOTE: Screws located at bottom edge of front panel do not have to be removed as holes in front panel are slotted.

NOTE: Top edge of front panel is held in place by two spring clips located on the bottom of the front flange of the cabinet top. See Figure 5-19

- Insert putty knife between cabinet top and top edge of front panel, approximately three inches in from side. See Figure 5-19.
- Push in on putty knife and at the same time pull top edge of front panel away from front of washer. Repeat for opposite side.
- Lift front panel off the two screws and set panel aside.
- Remove two cabinet top hold-down screws. See Figure 5-24.
- If area or space permits, tape loading door closed and lift cabinet top to a vertical position by hinging it on the rear hinges.

NOTE: Cabinet top is self supporting, however, a small chain may be used for additional support. See Figure 5-25.

- Loosen hose clamps and remove pressure hose from pressure bulb and filler hose from tub cover.
- Loosen hose clamp and remove drain hose from pump.
- Disconnect wire harness from motor switch by pressing down on locking tab on top of connection block and at the same time pull connection block away from motor switch. See Figure 5-21. Disconnect harness from leg by squeezing tabs on cable tie together and push it back through hole in leg.

IMPORTANT: To avoid an open circuit, DO NOT pull on terminal block wires when removing block from motor switch as this could damage wires or connection crimpings. Before attaching wire harness connection block to motor switch, make sure all male terminals on motor switch are straight and are capable of accepting terminals from wire harness connection block.

- Using No. 289P4 Spring Hook Tool, unhook six module springs from lower edge of outer tub. See Figure 5-36.

IMPORTANT: When installing module springs, make sure spring hook is fully seated in hole in tub skirt. Mark the word “FRONT” on the front side of the outer tub so complete tub module can be reinstalled in the same position.

- Grasp outer tub and lift complete tub module assembly (with transmission and weldment assembly attached) straight up and out of washer cabinet and set out of the way.
- Remove old friction ring from washer base. See Figure 5-43.
- Use a dry cloth or a cloth dampened with water and clean the surface of the base where new friction ring will be installed.
- Carefully place complete tub module back into washer making sure the weldment assembly (pivot dome area) is positioned properly over the friction ring and the recess area of washer base. See Figure 5-43.

NOTE: Be sure the word “FRONT” (on outer tub) is facing toward front of washer.

- Use the No. 289P4 Spring Hook Tool and starting with the rear springs, hook six module springs into lower edge of outer tub. See Figure 5-36.

IMPORTANT: When installing module springs, make sure spring hook is fully seated in hole in tub skirt. See Figure 5-36.



WARNING

To reduce the risk of electric shock, fire, explosion, serious injury or death:

- Disconnect electric power to the washer before servicing.
- Never start the washer with any guards/panels removed.
- Whenever ground wires are removed during servicing, these ground wires must be reconnected to ensure that the washer is properly grounded.

W003

- o. Connect hose to pump, then tighten hose clamp.
- p. Reconnect the connection block to motor switch. See Figure 5-21. Reinstall cable tie in leg making sure it is secure.
- q. Reconnect pressure hose to pressure bulb. See Figure 5-44. Then connect filler hose to tub cover. See Figure 5-44.

NOTE: When reinstalling filler hose, white line on hose that connects to tub cover must be aligned with line on top side of outer tub cover. See Figure 5-44. Make sure hose is in its natural position (not kinked or twisted). If hose is not, loosen hose clamp and straighten hose.

- r. Reinstall cabinet top and washer front panel.
- s. Reconnect washer power cord and open water supply faucets.

NOTE: Washer must be run through a complete cycle to make sure it is operating properly.

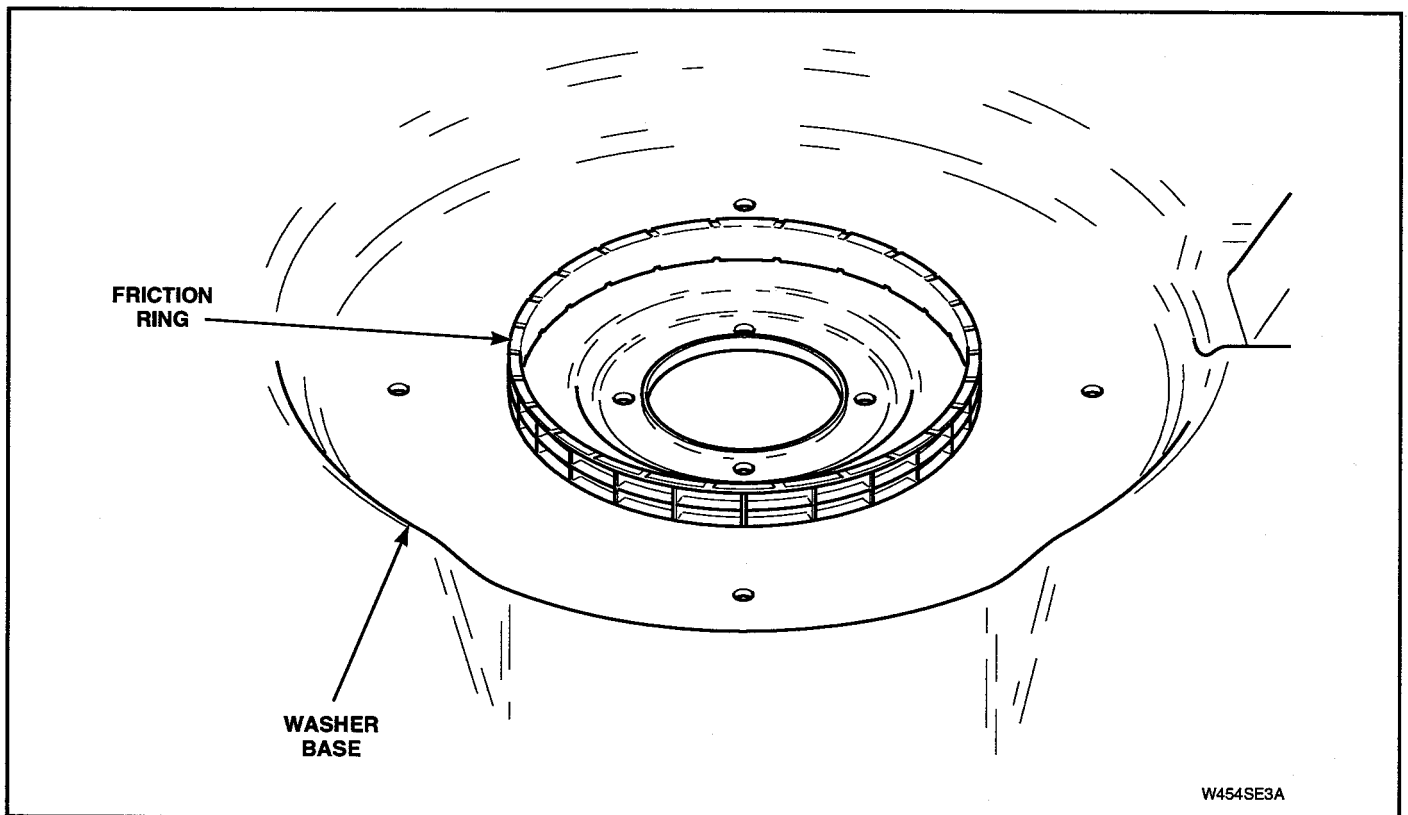

W454SE3A

Figure 5-43

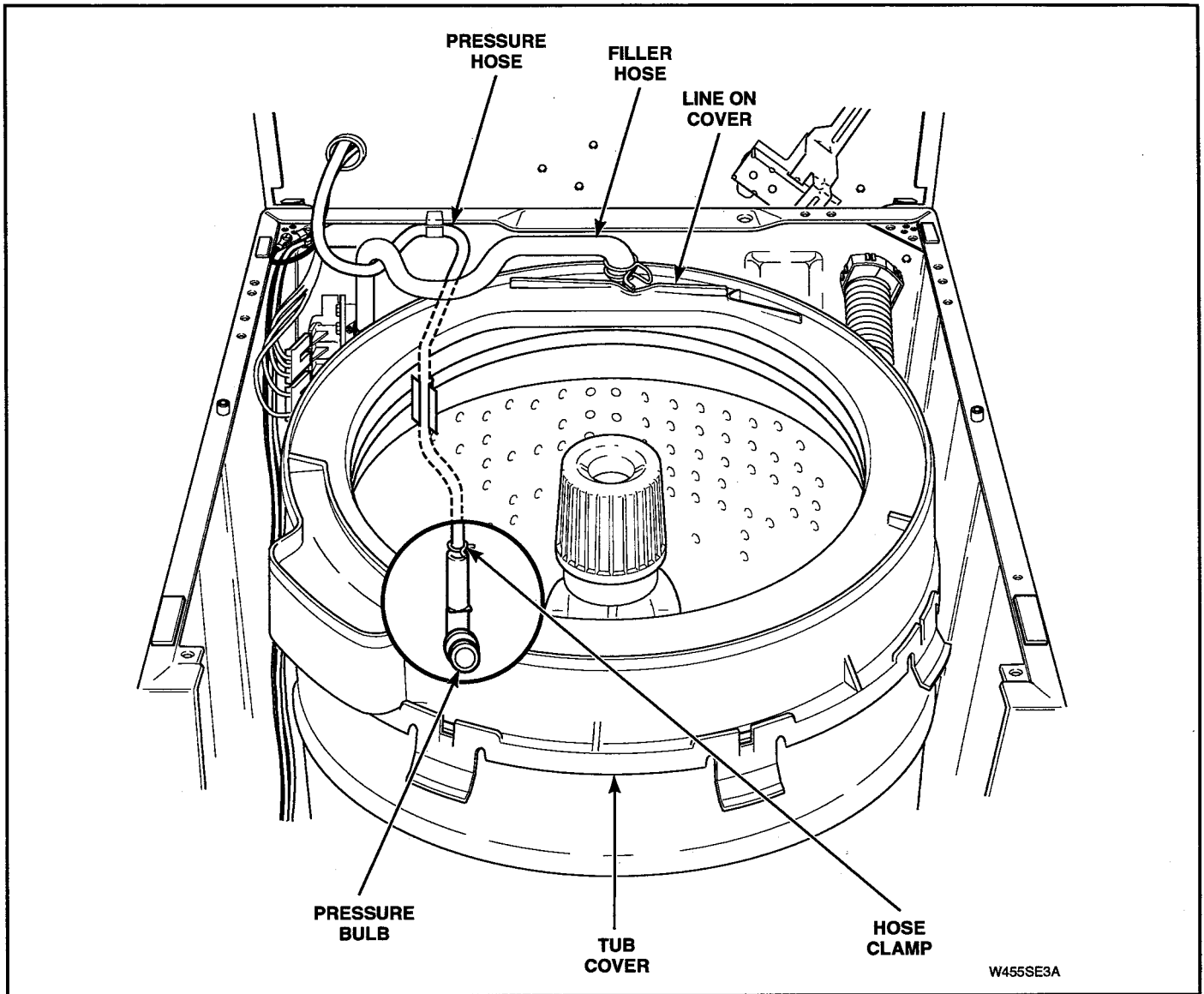

Figure 5-44

SECTION 6

Adjustments

1. LEVELING LEGS (Refer to Figure 6-1)

- a. Place rubber feet on all four leveling legs.
- b. Place washer in position on a clean, dry, and reasonably firm floor.
- c. Loosen locknuts and adjust two front leveling legs. Once adjusted, tilt washer forward on front legs and lower back down into position to set the rear self-leveling legs.

- d. Washer must not rock. After washer is at desired height, tighten locknuts securely against bottom of washer base. If these locknuts are not tight, washer will not remain stationary during operation.

NOTE: Improper installation, installation on carpet or flexing of a weak floor will cause excessive vibration.

IMPORTANT: Do not slide washer across floor once leveling legs have been extended, as legs and base could become damaged.

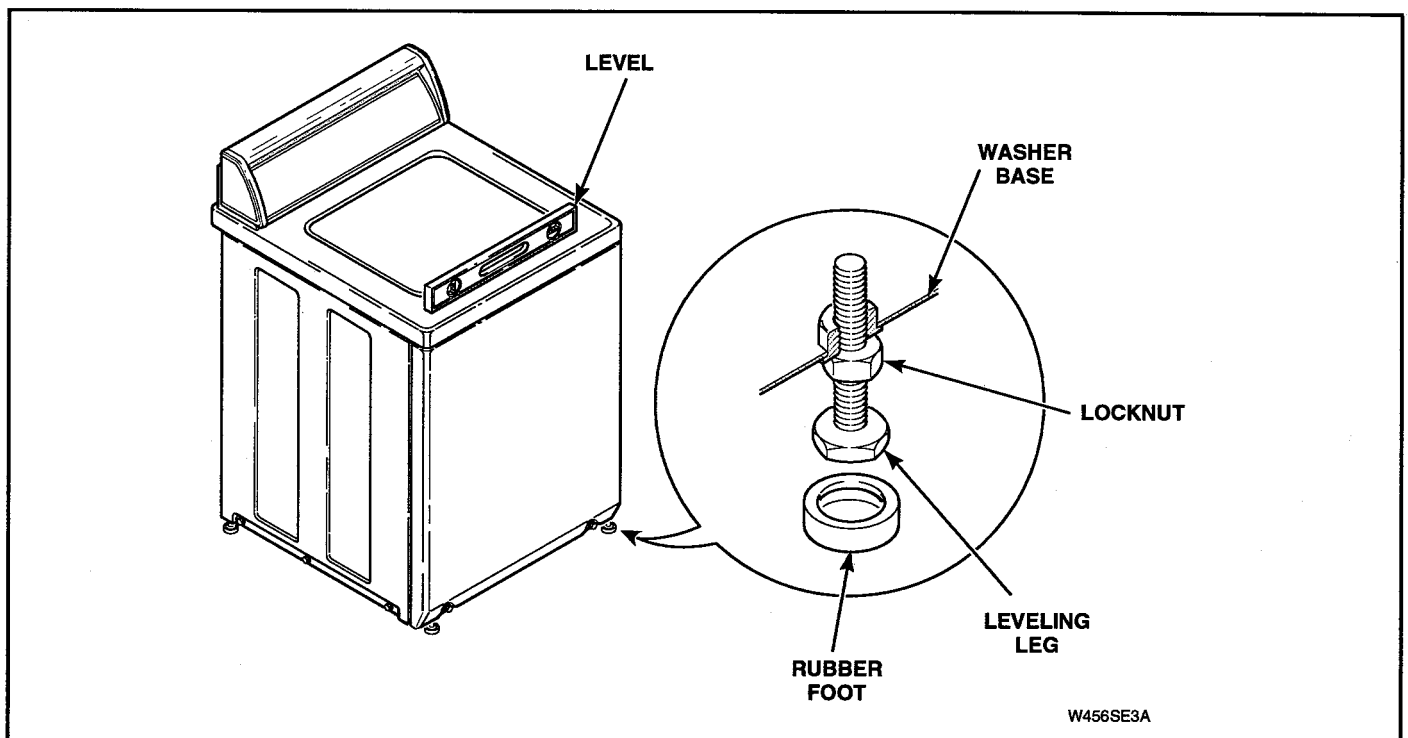

Figure 6-1

2. PRESSURE SWITCH (Refer to Figure 6-2)

IMPORTANT: Electronic pressure switch does not have an adjustment.

NOTE: DO NOT ADJUST PRESSURE SWITCH IF WASHER IS WITHIN THE WARRANTY PERIOD.

Pressure switch is set at the factory for proper water fill levels. However, if there is a problem of overfilling or underfilling, pressure switch can be adjusted.

Maximum water fill level can be increased by turning adjusting screw **CLOCKWISE**, and decreased by turning screw **COUNTERCLOCKWISE**.

One quarter turn of the adjusting screw represents approximately one inch (25.4 mm) increase or decrease of water level in washtub.

IMPORTANT: DO NOT turn adjusting screw more than 3/4 of a turn in either direction as the switch may be damaged and flooding could result.

3. BELT (Agitate and Spin)

No belt adjustment is required.

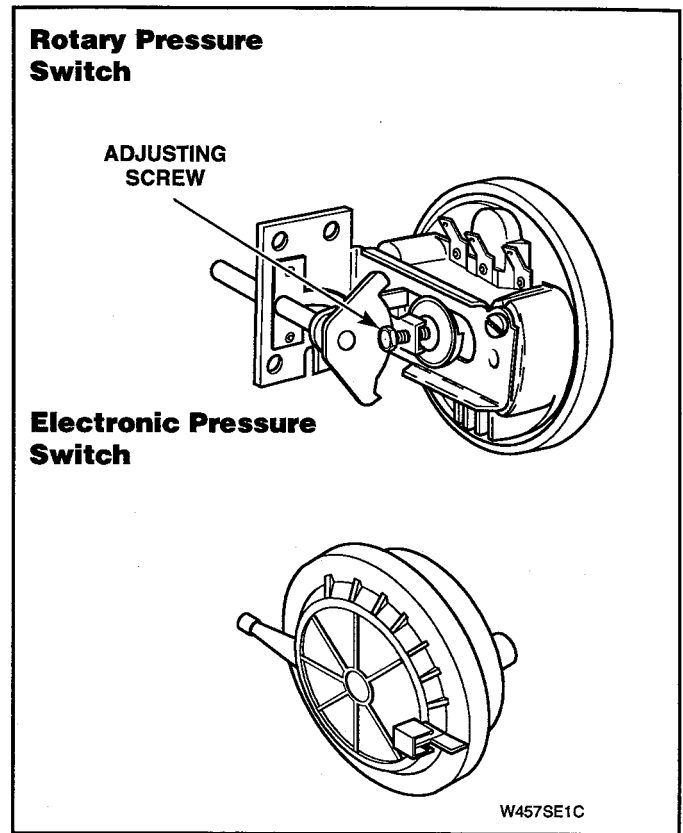



Figure 6-2

SECTION 7

Test Procedures

	WARNING
<p>To reduce the risk of electric shock, fire, explosion, serious injury or death:</p> <ul style="list-style-type: none"> • Disconnect electric power to the washer before servicing. • Never start the washer with any guards/panels removed. • Whenever ground wires are removed during servicing, these ground wires must be reconnected to ensure that the washer is properly grounded. 	
W003	

EMERSON MOTOR SWITCH (One or Two Speed Motors)

NOTE: Refer to SECTION 10 for Internal Wiring of Washer Motor Switch.

	WARNING
<p>Disconnect electric power to washer before performing the following steps, or when replacing switch.</p>	
W165	

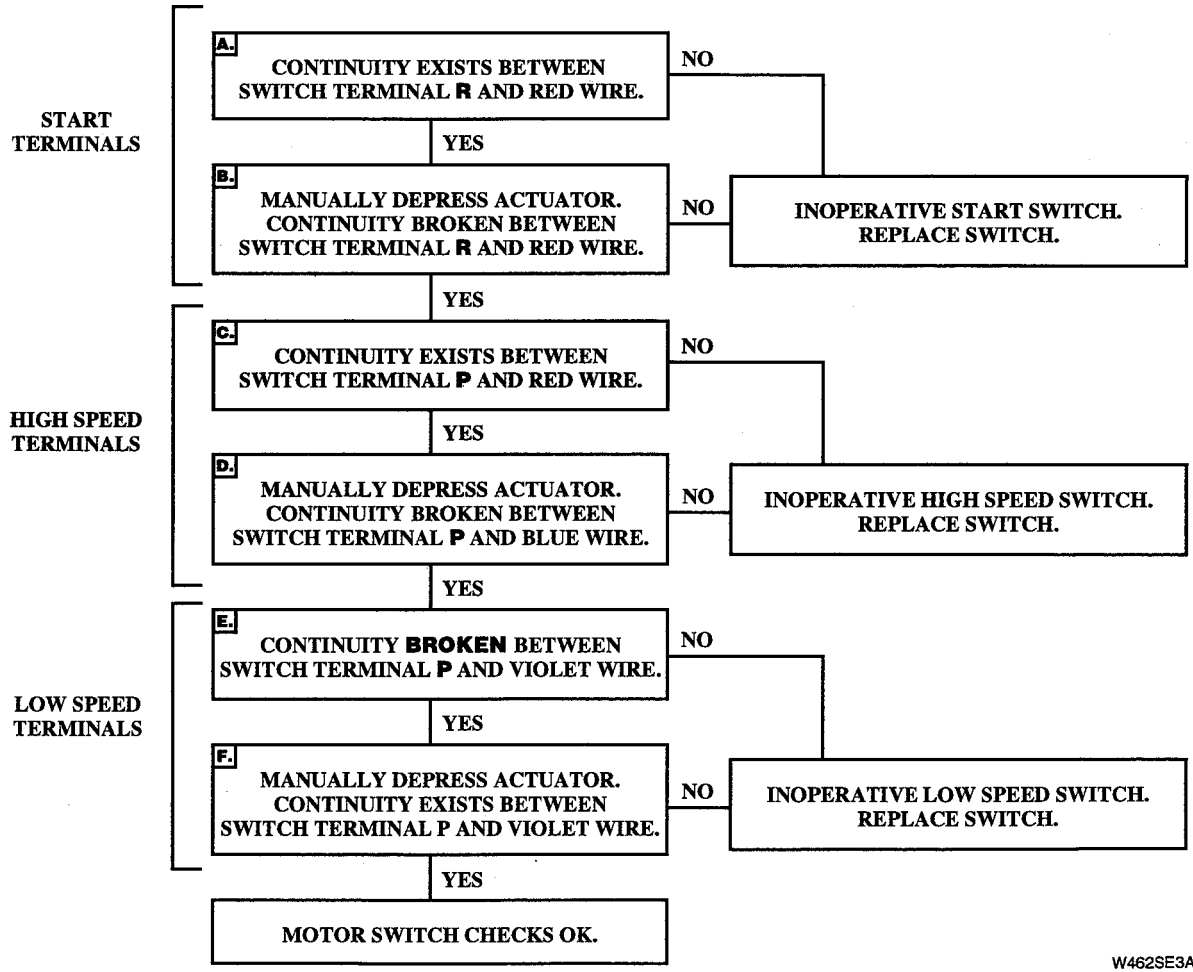

W462SE3A



WARNING

To reduce the risk of electric shock, fire, explosion, serious injury or death:

- Disconnect electric power to the washer before servicing.
- Never start the washer with any guards/panels removed.
- Whenever ground wires are removed during servicing, these ground wires must be reconnected to ensure that the washer is properly grounded.

W003

EMERSON MOTOR SWITCH (One or Two Speed Motors)

NOTE: Refer to SECTION 10 for Internal Wiring of Washer Motor Switch.



WARNING

Disconnect electric power to washer before performing the following steps, or when replacing switch.

W165

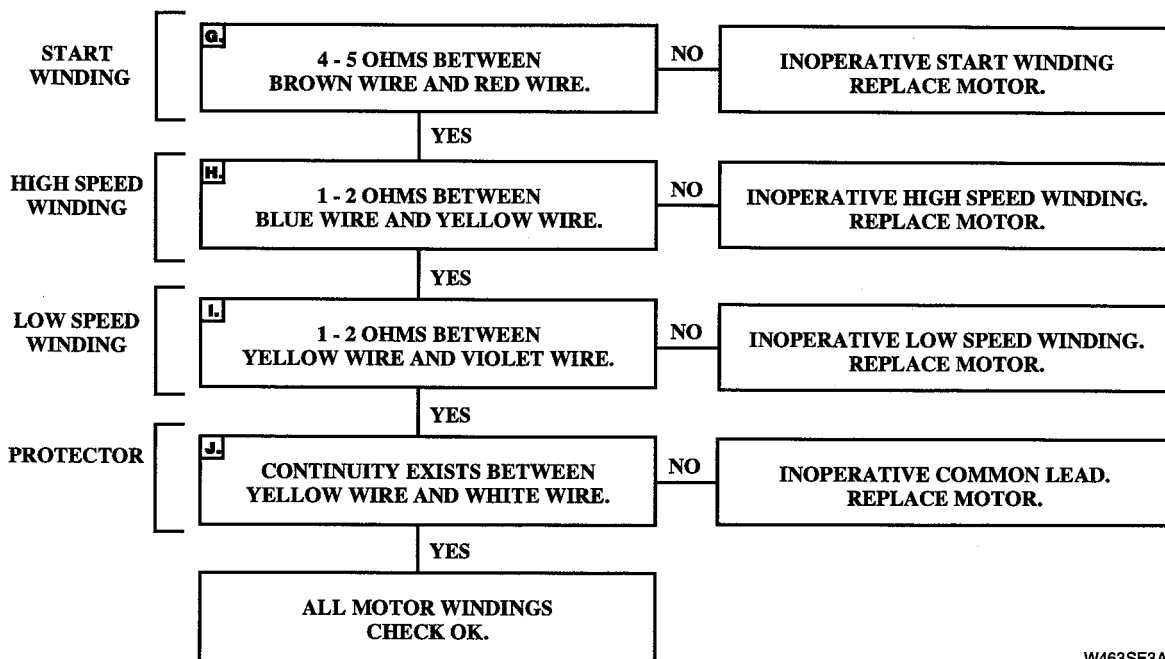

W463SE3A



WARNING

To reduce the risk of electric shock, fire, explosion, serious injury or death:

- Disconnect electric power to the washer before servicing.
- Never start the washer with any guards/panels removed.
- Whenever ground wires are removed during servicing, these ground wires must be reconnected to ensure that the washer is properly grounded.

W003

EMERSON MOTOR SWITCH (Three Speed Motors)

NOTE: Refer to SECTION 10 for Internal Wiring of Washer Motor Switch.



WARNING

Disconnect electric power to washer before performing the following steps, or when replacing switch.

W165

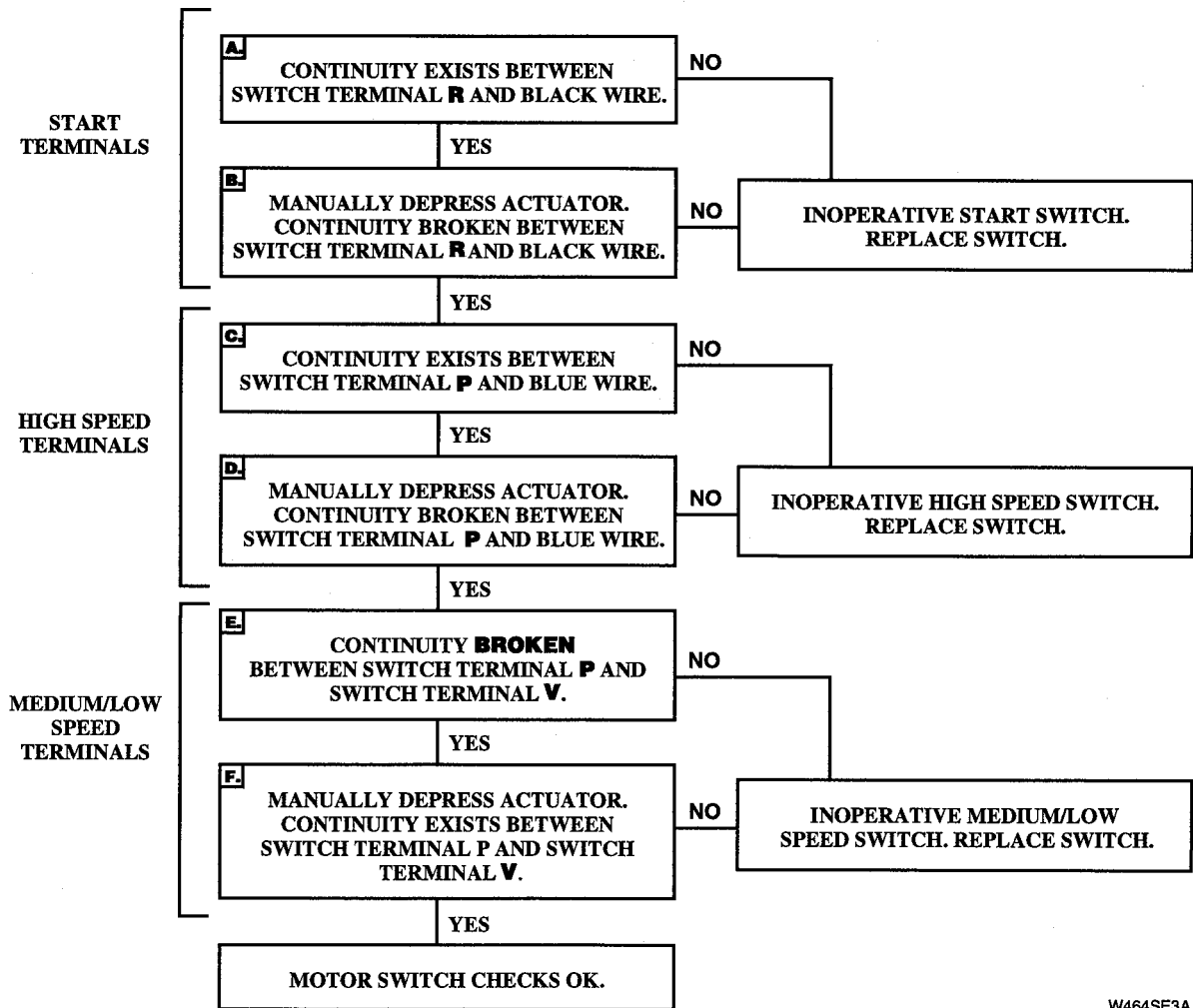

W464SE3A



WARNING

To reduce the risk of electric shock, fire, explosion, serious injury or death:

- Disconnect electric power to the washer before servicing.
- Never start the washer with any guards/panels removed.
- Whenever ground wires are removed during servicing, these ground wires must be reconnected to ensure that the washer is properly grounded.

W003

EMERSON MOTOR SWITCH (Three Speed Motors)

NOTE: Refer to SECTION 10 for Internal Wiring of Washer Motor Switch.



WARNING

Disconnect electric power to washer before performing the following steps, or when replacing switch.

W165

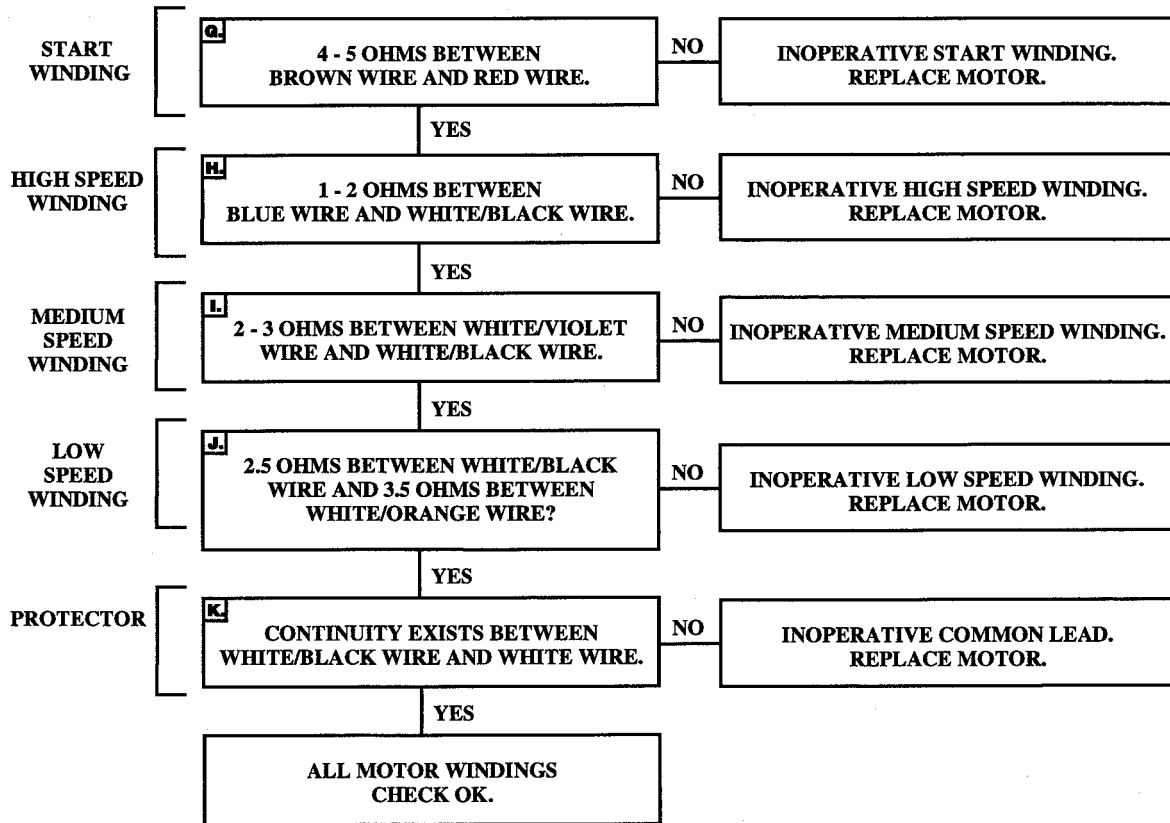

W465SE3A

SECTION 8

Cycle Sequence Charts

NOTE: Times listed are approximate.

CYCLE	FUNCTION	WATER TEMP. SELECT	* MOTOR SPEED	TIME (MIN: SEC)
SOAK	SOAK, FILL AND AGITATE	H, W, C	M	3:00
	SOAK FILL	H, W, C		12:00
	SPIN		M	3:00
OFF				3:00
PRE WASH	WASH, FILL AND AGITATE	H, W, C	F	6:00
	SPIN		F	3:00
REGULAR	WASH, FILL AND AGITATE	H, W, C	F	15:00
	SPIN		F	3:00
	SPIN AND SPRAY	C	F	:24
	SPIN		F	2:36
	RINSE, FILL AND AGITATE	W, C	F	3:00
	SPIN		F	6:00
OFF/PAUSE	CYCLE END OR PAUSE FOR EXTRA RINSE			3:00
EXTRA RINSE	RINSE, FILL AND AGITATE	W, C	F	3:00
	SPIN		F	6:00
OFF				OFF
PERMANENT PRESS	WASH, FILL AND AGITATE	H, W, C	F	9:00
	SPIN		M	3:00
	SPIN AND SPRAY	C	M	:24
	SPIN		M	2:36
OFF/PAUSE	CYCLE END OR PAUSE FOR EXTRA RINSE			3:00
EXTRA RINSE	RINSE, FILL AND AGITATE	W, C	F	3:00
	SPIN		F	6:00
OFF				3:00
DELICATE	WASH, FILL AND SOAK	H, W, C		3:00
	WASH, FILL AND AGITATE	H, W, C	M	:24
	WASH, FILL AND SOAK	H, W, C		2:36
	WASH, FILL AND AGITATE	H, W, C	M	:24
	WASH, FILL AND SOAK	H, W, C		2:36
	SPIN		M	3:00
	SPIN AND SPRAY	C	M	:22
	SPIN		M	2:38
	RINSE, FILL AND AGITATE	C	M	3:00
	SPIN		M	3:00
	OFF/PAUSE	CYCLE END OR PAUSE		
EXTRA RINSE	RINSE, FILL AND AGITATE	C	M	3:00
	SPIN		M	3:00
OFF				3:00
HANDWASH	WASH, FILL AND SOAK	H, W, C		3:00
	WASH, FILL AND AGITATE	H, W, C	S	:24
	WASH, FILL AND SOAK	H, W, C		2:36
	WASH, FILL AND AGITATE	H, W, C	S	:24
	WASH, FILL AND SOAK	H, W, C		2:36
	SPIN		M	3:00
	SPIN AND SPRAY	C	M	:22
	SPIN		M	2:38
	RINSE, FILL AND AGITATE	C	S	3:00
	SPIN		M	3:00
	OFF			

*On Single Speed Model Washers, All Speeds Are Fast.

KEY:

H = HOT W = WARM C = COLD
 F = FAST M = MEDIUM S = SLOW

TIMER NO. 37919 CYCLE SEQUENCE

NOTE: Times listed are approximate.

CYCLE	FUNCTION	WATER TEMP. SELECT	*MOTOR SPEED	TIME (MIN: SEC)
SOAK	SOAK, FILL AND AGITATE	H, W, C	F, M, S	3:00
	SOAK FILL	H, W, C		12:00
	SPIN		F, M, S	3:00
OFF				3:00
PRE WASH	WASH, FILL AND AGITATE	H, W, C	F, M, S	6:00
	SPIN		F, M, S	3:00
REGULAR	WASH, FILL AND AGITATE	H, W, C	F, M, S	15:00
	SPIN		F, M, S	3:00
	SPIN AND SPRAY	C	F, M, S	:24
	SPIN		F, M, S	2:36
	RINSE, FILL AND AGITATE	W, C	F, M, S	3:00
	SPIN		F, M, S	6:00
OFF/PAUSE	CYCLE END OR PAUSE FOR EXTRA RINSE			3:00
EXTRA RINSE	RINSE, FILL AND AGITATE	W, C	F, M, S	3:00
	SPIN		F, M, S	6:00
OFF				OFF
PERMANENT PRESS	WASH, FILL AND AGITATE	H, W, C	F, M, S	9:00
	SPIN		S	3:00
	SPIN AND SPRAY	C	S	:24
	SPIN		S	2:36
	RINSE, FILL AND AGITATE	W, C	F, M, S	3:00
	SPIN		F, M, S	6:00
OFF/PAUSE	CYCLE END OR PAUSE FOR EXTRA RINSE			3:00
EXTRA RINSE	RINSE, FILL AND AGITATE	W, C	F, M, S	3:00
	SPIN		F, M, S	6:00
OFF				3:00
DELICATE	WASH, FILL AND SOAK	H, W, C		3:00
	WASH, FILL AND AGITATE	H, W, C	S	:24
	WASH, FILL AND SOAK	H, W, C		2:36
	WASH, FILL AND AGITATE	H, W, C	S	:24
	WASH, FILL AND SOAK	H, W, C		2:36
	SPIN		S	3:00
	SPIN AND SPRAY	C	S	:22
	SPIN		S	2:38
	RINSE, FILL AND AGITATE	C	S	3:00
	SPIN		S	3:00
OFF/PAUSE	CYCLE END OR PAUSE			3:00
EXTRA RINSE	RINSE, FILL AND AGITATE	C	S	3:00
	SPIN		S	3:00
OFF				3:00

*On Single Speed Model Washers, All Speeds Are Fast.

KEY:

H = HOT W = WARM C = COLD
 F = FAST M - MEDIUM S = SLOW

TIMER NO. 37921 CYCLE SEQUENCE

NOTE: Times listed are approximate.

CYCLE	FUNCTION	WATER TEMP. SELECT	* MOTOR SPEED	TIME (MIN: SEC)
SOAK	SOAK, FILL AND AGITATE	H, W, C	F, M, S	3:00
	SOAK FILL	H, W, C		12:00
	SPIN		F, M, S	3:00
OFF				3:00
PRE WASH	WASH, FILL AND AGITATE	H, W, C	F, M, S	6:00
	SPIN		F, M, S	3:00
REGULAR	WASH, FILL AND AGITATE	H, W, C	F, M, S	15:00
	SPIN		F, M, S	3:00
	SPIN AND SPRAY	C	F, M, S	:24
	SPIN		F, M, S	2:36
	RINSE, FILL AND AGITATE	W, C	F, M, S	3:00
	SPIN		F, M, S	6:00
OFF/PAUSE	CYCLE END OR PAUSE FOR EXTRA RINSE			3:00
EXTRA RINSE	RINSE, FILL AND AGITATE	W, C	F, M, S	3:00
	SPIN		F, M, S	6:00
OFF				OFF
PERMANENT PRESS	WASH, FILL AND AGITATE	H, W, C	F, M, S	9:00
	SPIN		M	3:00
	SPIN AND SPRAY	C	M	:24
	SPIN		M	2:36
	RINSE, FILL AND AGITATE	W, C	F, M, S	3:00
	SPIN		F, M, S	6:00
OFF/PAUSE	CYCLE END OR PAUSE FOR EXTRA RINSE			3:00
EXTRA RINSE	RINSE, FILL AND AGITATE	W, C	F, M, S	3:00
	SPIN		F, M, S	6:00
OFF				3:00
DELICATE	WASH, FILL AND SOAK	H, W, C		3:00
	WASH, FILL AND AGITATE	H, W, C	M	:24
	WASH, FILL AND SOAK	H, W, C		2:36
	WASH, FILL AND AGITATE	H, W, C	M	:24
	WASH, FILL AND SOAK	H, W, C		2:36
	SPIN		M	3:00
	SPIN AND SPRAY	C	M	:22
	SPIN		M	2:38
	RINSE, FILL AND AGITATE	C	M	3:00
	SPIN		M	3:00
	OFF/PAUSE	CYCLE END OR PAUSE		
EXTRA RINSE	RINSE, FILL AND AGITATE	C	M	3:00
	SPIN		M	3:00
OFF				3:00
HANDWASH	WASH, FILL AND SOAK	H, W, C		3:00
	WASH, FILL AND AGITATE	H, W, C	S	:24
	WASH, FILL AND SOAK	H, W, C		2:36
	WASH, FILL AND AGITATE	H, W, C	S	:24
	WASH, FILL AND SOAK	H, W, C		2:36
	SPIN		M	3:00
	SPIN AND SPRAY	C	M	:22
	SPIN		M	2:38
	RINSE, FILL AND AGITATE	C	S	3:00
	SPIN		M	3:00
OFF				3:00

*On Single Speed Model Washers, All Speeds Are Fast.

KEY:

H = HOT W = WARM C = COLD
 F = FAST M - MEDIUM S = SLOW

TIMER NO. 37922 CYCLE SEQUENCE

NOTE: Times listed are approximate.

CYCLE	FUNCTION	WATER TEMP. SELECT	* MOTOR SPEED	TIME (MIN: SEC)
SOAK	SOAK, FILL AND AGITATE	H, W, C	S	3:00
	SOAK FILL	H, W, C		12:00
	SPIN		S	3:00
OFF				6:00
REGULAR	WASH, FILL AND AGITATE	H, W, C	F	15:00
	SPIN		F	3:00
	SPIN AND SPRAY	C	F	:24
	SPIN		F	2:36
	RINSE, FILL AND AGITATE	W, C	F	3:00
	SPIN		F	6:00
OFF/PAUSE	CYCLE END OR PAUSE FOR EXTRA RINSE			3:00
EXTRA RINSE	RINSE, FILL AND AGITATE	W, C	F	3:00
	SPIN		F	6:00
OFF				6:00
PERMANENT PRESS	WASH, FILL AND AGITATE	H, W, C	F	9:00
	SPIN		S	3:00
	SPIN AND SPRAY	C	S	:24
	SPIN		S	2:36
	RINSE, FILL AND AGITATE	W, C	F	3:00
	SPIN		F	6:00
OFF/PAUSE	CYCLE END OR PAUSE FOR EXTRA RINSE			3:00
EXTRA RINSE	RINSE, FILL AND AGITATE	W, C	F	3:00
	SPIN		F	6:00
OFF				6:00
DELICATE	WASH, FILL AND SOAK	H, W, C		3:00
	WASH, FILL AND AGITATE	H, W, C	S	:24
	WASH, FILL AND SOAK	H, W, C		2:36
	WASH, FILL AND AGITATE	H, W, C	S	:24
	WASH, FILL AND SOAK	H, W, C		2:36
	SPIN		S	3:00
	SPIN AND SPRAY	C	S	:24
	SPIN		S	2:36
	RINSE, FILL AND AGITATE	C	S	3:00
	SPIN		S	3:00
	OFF/PAUSE	CYCLE END OR PAUSE		
EXTRA RINSE	RINSE, FILL AND AGITATE	C	S	3:00
	SPIN		S	3:00
OFF				6:00

*On Single Speed Model Washers, All Speeds Are Fast.

KEY:

H = HOT W = WARM C = COLD
 F = FAST M = MEDIUM S = SLOW

TIMER NO. 37926 CYCLE SEQUENCE

NOTE: Times listed are approximate.

CYCLE	FUNCTION	WATER TEMP. SELECT	* MOTOR SPEED	TIME (MIN: SEC)
SOAK	SOAK, FILL AND AGITATE	H, W, C	S	4:00
	SOAK FILL	H, W, C		12:00
	SPIN		S	4:00
OFF				4:00
REGULAR	WASH, FILL AND AGITATE	H, W, C	F	15:30
	SPIN		F	2:00
	SPIN AND SPRAY	C	F	:30
	SPIN		F	1:30
	RINSE, FILL AND AGITATE	W, C	F	4:00
	SPIN		F	6:00
OFF				4:00
PERMANENT PRESS	WASH, FILL AND AGITATE	H, W, C	F	9:30
	SPIN		S	2:00
	SPIN AND SPRAY	C	S	:30
	SPIN		S	1:30
	RINSE, FILL AND AGITATE	W, C	F	4:00
	SPIN		F	6:00
OFF				4:00
DELICATE	WASH, FILL AND SOAK	H, W, C		3:00
	WASH, FILL AND AGITATE	H, W, C	S	:30
	WASH, FILL AND SOAK	H, W, C		1:30
	WASH, FILL AND AGITATE	H, W, C	S	:30
	WASH, FILL AND SOAK	H, W, C		1:30
	WASH, FILL AND AGITATE	H, W, C	S	:30
	WASH, FILL AND SOAK	H, W, C		1:30
	WASH, FILL AND AGITATE	H, W, C	S	:30
	WASH, FILL AND SOAK	H, W, C		1:30
	SPIN		S	2:00
	SPIN AND SPRAY	C	S	:30
	SPIN		S	1:30
	RINSE, FILL AND AGITATE	C	S	4:00
	SPIN		S	4:00
	OFF			

*On Single Speed Model Washers, All Speeds Are Fast.

KEY:

H = HOT W = WARM C = COLD
 F = FAST M = MEDIUM S = SLOW

TIMER NO. 37927 CYCLE SEQUENCE

NOTE: Times listed are approximate.

CYCLE	FUNCTION	WATER TEMP. SELECT	* MOTOR SPEED	TIME (MIN: SEC)
REGULAR	WASH, FILL AND AGITATE	H, W, C	F	15:00
	SPIN		F	1:30
	SPIN AND SPRAY	C	F	:25
	SPIN		F	2:35
	RINSE, FILL AND AGITATE	W, C	F	3:00
	SPIN		F	6:00
OFF				3:00
PERMANENT PRESS	WASH, FILL AND AGITATE	H, W, C	F	9:00
	SPIN		S	1:30
	SPIN AND SPRAY	C	S	:25
	SPIN		S	2:35
	RINSE, FILL AND AGITATE	W, C	F	3:00
	SPIN		F	6:00
OFF				
DELICATE	WASH, FILL AND SOAK	H, W, C		1:30
	WASH, FILL AND AGITATE	H, W, C	S	:25
	WASH, FILL AND SOAK	H, W, C		2:35
	WASH, FILL AND AGITATE	H, W, C	S	:25
	WASH, FILL AND SOAK	H, W, C		2:35
	WASH, FILL AND AGITATE	H, W, C	S	:25
	WASH, FILL AND SOAK	H, W, C		1:05
	SPIN		S	1:30
	SPIN AND SPRAY	C	S	:25
	SPIN		S	2:35
	RINSE, FILL AND AGITATE	C	S	3:00
	SPIN		S	3:00
OFF				

*On Single Speed Model Washers, All Speeds Are Fast.

KEY:

H = HOT W = WARM C = COLD
 F = FAST M = MEDIUM S = SLOW

TIMER NO. 37929 CYCLE SEQUENCE

REGULAR CYCLE

FUNCTION	TIME	WASH	SPIN	WATER TEMP (Options)
Water Fill	Variable			W (H, RH, W, RC, C)
Agitate	Soil Time	High		
Pause	0:10			
Spin	1:30		High	
Spin, Spray	0:30		High	C
Spin	2:00		High	
Water Fill (XR)	Variable			C (W, C)
Agitate (XR)	4:00	High		
Pause (XR)	0:10			
Spin (XR)	3:00		High	
Water Fill	Variable			C (W, C)
Agitate	4:00	High		
Pause	0:10			
Spin	7:00		High	

KEY:

STATUS	RELAYS (Energized)	WATER TEMP
W - Wash	H - Hot (K5)	H - Hot
R - Rinse	C - Cold (K6)	RH - Regulated Hot (120°F)
SK - Soak	HA - High Agitate (K1)	W - Warm
Sp - Spin	LA - Low Agitate (K1, K2)	RC - Regulated Cold (70°F)
XR - Extra Rinse	HS - High Spin (K1, K3)	C - Cold
	LS - Low Spin (K1, K2, K3)	WR - Warm Rinse
	MA - Medium Agitate (K1, K2, K7)	
	MS - Medium Spin (K1, K2, K3, K7)	

ELECTRONIC CONTROL CYCLE SEQUENCE

PERM PRESS CYCLE

FUNCTION	TIME	WASH	SPIN	WATER TEMP (Options)
Water Fill	Variable			W (H, RH, W, RC, C)
Agitate	Soil Time	High		
Pause	0:10			
Spin	1:30		Med	
Spin, Spray	0:30		Med	C
Spin	2:00		Med	
Water Fill (XR)	Variable			C (No WR)
Agitate (XR)	3:00	High		
Pause (XR)	0:10			
Spin (XR)	3:00		Med	
Water Fill	Variable			C (No WR)
Agitate	3:00	High		
Pause	0:10			
Spin	6:00		High	

KEY:

STATUS	RELAYS (Energized)	WATER TEMP
W - Wash	H - Hot (K5)	H - Hot
R - Rinse	C - Cold (K6)	RH - Regulated Hot (120°F)
SK - Soak	HA - High Agitate (K1)	W - Warm
Sp - Spin	LA - Low Agitate (K1, K2)	RC - Regulated Cold (70°F)
XR - Extra Rinse	HS - High Spin (K1, K3)	C - Cold
	LS - Low Spin (K1, K2, K3)	WR - Warm Rinse
	MA - Medium Agitate (K1, K2, K7)	
	MS - Medium Spin (K1, K2, K3, K7)	

ELECTRONIC CONTROL CYCLE SEQUENCE

KNIT CYCLE

FUNCTION	TIME	WASH	SPIN	WATER TEMP (Options)
Water Fill	Variable			W (W, RC, C)
Agitate / Pause 0:10 Agitate 0:30 Pause	Soil Time	Med		
Spin	1:30		High	
Spin, Spray	0:30		High	C
Spin	1:30		High	
Water Fill (XR)	Variable			C (No WR)
Agitate (XR)	1:00	Med		
Pause (XR)	0:10			
Spin (XR)	3:00		High	
Water Fill	Variable			C (No WR)
Agitate	1:00	Med		
Pause	0:10			
Spin	5:00		High	

KEY:

STATUS	RELAYS (Energized)	WATER TEMP
W - Wash	H - Hot (K5)	H - Hot
R - Rinse	C - Cold (K6)	RH - Regulated Hot (120°F)
SK - Soak	HA - High Agitate (K1)	W - Warm
Sp - Spin	LA - Low Agitate (K1, K2)	RC - Regulated Cold (70°F)
XR - Extra Rinse	HS - High Spin (K1, K3)	C - Cold
	LS - Low Spin (K1, K2, K3)	WR - Warm Rinse
	MA - Medium Agitate (K1, K2, K7)	
	MS - Medium Spin (K1, K2, K3, K7)	

DELICATE CYCLE

FUNCTION	TIME	WASH	SPIN	WATER TEMP (Options)
Water Fill	Variable			W (W, RC, C)
Agitate / Pause 1:00 Agitate 1:00 Pause	Soil Time	Med		
Spin	1:30		Med	
Spin, Spray	0:30		Med	C
Spin	1:30		Med	
Water Fill (XR)	Variable			C (No WR)
Agitate (XR)	1:00	Med		
Pause (XR)	0:10			
Spin (XR)	3:00		Med	
Water Fill	Variable			C (No WR)
Agitate	1:00	Med		
Pause	0:10			
Spin	5:00		Med	C (No WR)

KEY:

STATUS	RELAYS (Energized)	WATER TEMP
W - Wash	H - Hot (K5)	H - Hot
R - Rinse	C - Cold (K6)	RH - Regulated Hot (120°F)
SK - Soak	HA - High Agitate (K1)	W - Warm
Sp - Spin	LA - Low Agitate (K1, K2)	RC - Regulated Cold (70°F)
XR - Extra Rinse	HS - High Spin (K1, K3)	C - Cold
	LS - Low Spin (K1, K2, K3)	WR - Warm Rinse
	MA - Medium Agitate (K1, K2, K7)	
	MS - Medium Spin (K1, K2, K3, K7)	

ELECTRONIC CONTROL CYCLE SEQUENCE

HANDWASH CYCLE

FUNCTION	TIME	WASH	SPIN	WATER TEMP (Options)
Water Fill	Variable			W (W, RC, C)
Agitate / Pause 1:00 Agitate 1:00 Pause	Soil Time	Low		
Spin	1:30		Med	
Spin, Spray	0:30		Med	C
Spin	1:30		Med	
Water Fill (XR)	Variable			C (No WR)
Agitate (XR)	1:00	Low		
Pause (XR)	0:10			
Spin (XR)	3:00		Med	
Water Fill	Variable			C (No WR)
Agitate	1:00	Low		
Pause	0:10			
Spin	5:00		Med	

KEY:

STATUS	RELAYS (Energized)	WATER TEMP
W - Wash	H - Hot (K5)	H - Hot
R - Rinse	C - Cold (K6)	RH - Regulated Hot (120°F)
SK - Soak	HA - High Agitate (K1)	W - Warm
Sp - Spin	LA - Low Agitate (K1, K2)	RC - Regulated Cold (70°F)
XR - Extra Rinse	HS - High Spin (K1, K3)	C - Cold
	LS - Low Spin (K1, K2, K3)	WR - Warm Rinse
	MA - Medium Agitate (K1, K2, K7)	
	MS - Medium Spin (K1, K2, K3, K7)	

ELECTRONIC CONTROL CYCLE SEQUENCE

SOAK CYCLE

FUNCTION	TIME	WASH	SPIN	WATER TEMP (Options)
Water Fill	Variable			W (H, RH, W, RC, C)
Agitate	2:00	Med		
Pause	Soil Time			
Spin	4:00		Med	

AUTO-PREWASH CYCLE

Water Fill	Variable			W (H, RH, W, RC, C)
Agitate	5:00	High		
Pause	0:10			
Spin	1:30		High	
Spin, Spray	0:30		High	C
Spin	2:00		High	

RINSE AND SPIN PREWASH CYCLE

Water Fill	Variable			C
Agitate	5:00	High		
Pause	0:10			
Spin	7:00		High	

AUTO PRESOAK CYCLE

Water Fill	Variable			W (H, RH, W, RC, C)
Agitate	2:00	High		
Pause / Soak	10:00			

KEY:

STATUS	RELAYS (Energized)	WATER TEMP
W - Wash	H - Hot (K5)	H - Hot
R - Rinse	C - Cold (K6)	RH - Regulated Hot (125°F)
SK - Soak	HA - High Agitate (K1)	RW - Regulated Warm (100°F)
Sp - Spin	LA - Low Agitate (K1, K2)	RC - Regulated Cold (75°F)
XR - Extra Rinse	HS - High Spin (K1, K3)	C - Cold
	LS - Low Spin (K1, K2, K3)	W - Warm Rinse (85°F)

ELECTRONIC CONTROL CYCLE SEQUENCE

SECTION 9

Service Procedures Unique to the Electronic Control Model Washers



WARNING

To reduce the risk of electric shock, fire, explosion, serious injury or death:

- Disconnect electric power to the washer before servicing.
- Never start the washer with any guards/panels removed.
- Whenever ground wires are removed during servicing, these ground wires must be reconnected to ensure that the washer is properly grounded.

W003

1. ELECTRICAL REQUIREMENTS

(120 Volt, 60 Hertz, With 3-Prong Grounding Plug)

NOTE: Wiring diagram is located in control hood.



WARNING

To reduce the risk of fire, electric shock or personal injury, all wiring and grounding **MUST** conform with the latest edition of the National Electrical Code, ANSI/NFPA 70, and such local regulations as might apply. It is the customer's responsibility to have the wiring and fuses checked by a qualified electrician to make sure your home has adequate electrical power to operate the washer.

W028

- Washer is designed to be operated on a separate branch, polarized, three-wire, effectively grounded, 120 Volt, 60 Hertz, AC (alternating current), single phase electrical circuit protected by a **15 or 20 ampere** fuse, equivalent fusetron or circuit breaker.
- Three-prong grounding plug on power cord should be plugged directly into a polarized three-slot effectively grounded receptacle rated 110/120 Volts AC (alternating current). See Figure 9-1.
- **Do not operate other appliances on the same circuit. Do not overload circuits! See Figure 9-2**

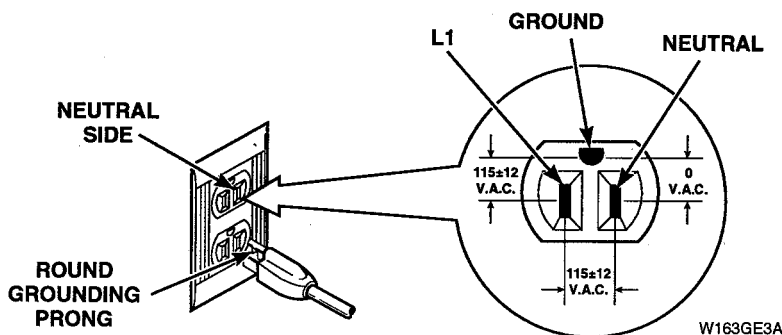

NOTE: A qualified electrician should check polarity of wall receptacle. If a voltage reading is measured, other than that illustrated, the qualified electrician should correct the problem.

Figure 9-1



WARNING

To reduce the risk of electric shock, fire, explosion, serious injury or death:

- Disconnect electric power to the washer before servicing.
- Never start the washer with any guards/panels removed.
- Whenever ground wires are removed during servicing, these ground wires must be reconnected to ensure that the washer is properly grounded.

W003

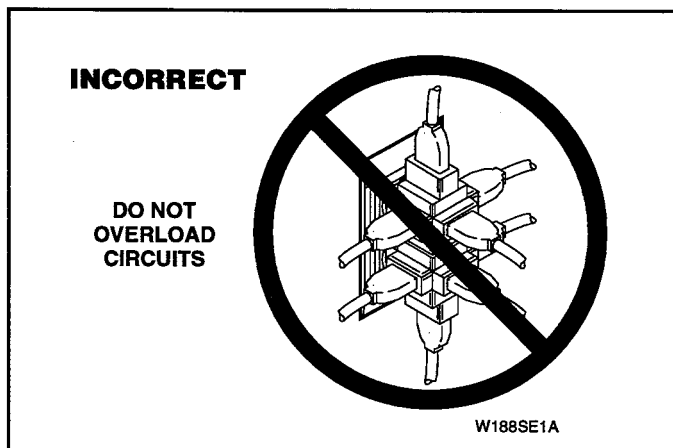

Figure 9-2



WARNING

To reduce the risk of an electric shock, serious injury, death or fire, **DO NOT** use an extension cord or an adapter to connect washer to electrical power source.

W169

2. GROUNDING INSTRUCTIONS

- Washer must be grounded. In event of malfunction or breakdown, grounding will reduce risk of electric shock by providing a path of least resistance for electric current. Washer is equipped with a cord having an equipment-grounding conductor and a three-prong grounding plug. Plug must be plugged into an appropriate outlet that is properly installed and grounded in accordance with all local codes and ordinances.



WARNING

Improper connection of the equipment-grounding conductor can result in a risk of electric shock. Check with a qualified electrician or service person if you are in doubt as to whether the dryer is properly grounded.

W038

- Do not modify plug provided with washer — If it will not fit outlet, have a proper outlet installed by a qualified electrician.
- If the home's electrical supply does not meet the above specifications and/or if you are not sure the home has an effective ground, have a qualified electrician, or your local electrical utility company check it and correct any problems.

3. WASHERS EQUIPPED WITH ELECTRONIC CONTROL

After connecting washer to electrical supply, start washer (refer to OPERATING INSTRUCTIONS supplied with washer).



WARNING

To reduce the risk of electric shock, fire, explosion, serious injury or death:

- Disconnect electric power to the washer before servicing.
- Never start the washer with any guards/panels removed.
- Whenever ground wires are removed during servicing, these ground wires must be reconnected to ensure that the washer is properly grounded.

W003

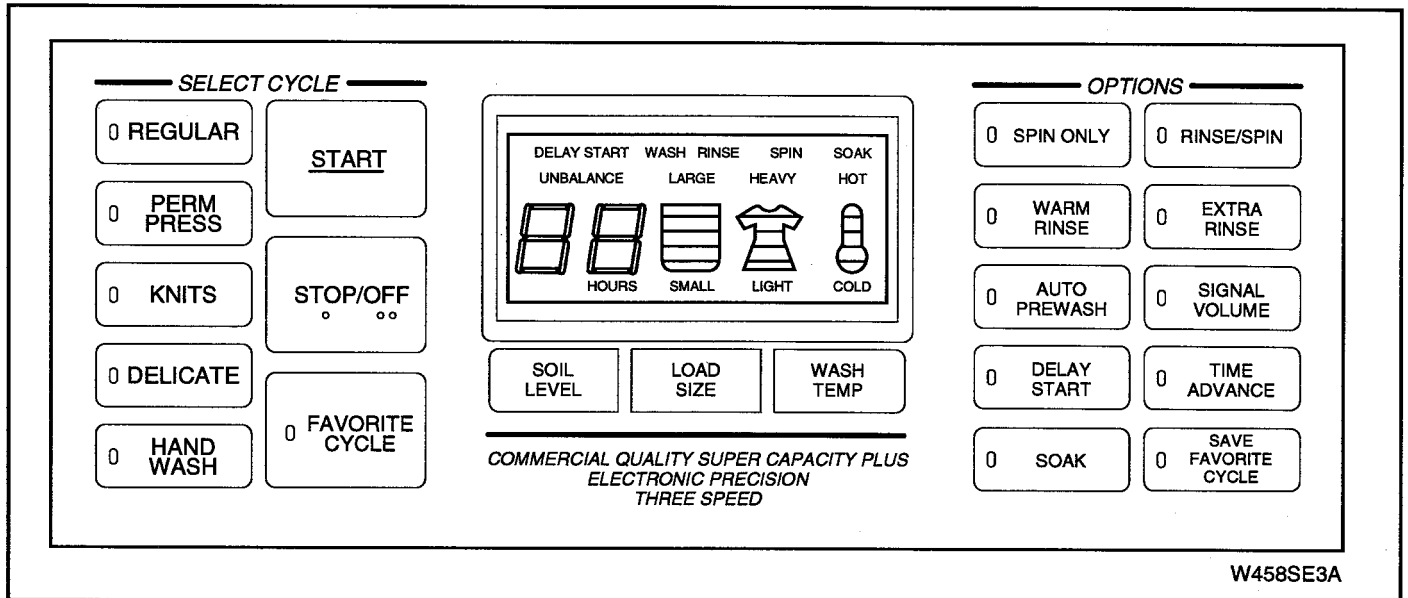

Figure 9-3

4. TROUBLESHOOTING ELECTRONIC CONTROL

IMPORTANT: This procedure is intended to be used as an aid in diagnosing potential problems with electronic control. See Figure 9-3. Refer to SECTION III (Troubleshooting) for diagnosing problems with components other than electronic control. For terminal numbers, connections and color coding see Figure 9-4.

5. DIAGNOSTIC CYCLE

A diagnostic cycle is built into the electronic control, to detect internal problems on printed circuit board of control.

IMPORTANT: Diagnostic cycle is not intended to diagnose any components built into the control (i.e. relays, transformer, or capacitors).

Diagnostic cycle is used in conjunction with a self-diagnostic routine chart located on writing diagram sticker. To begin the diagnostic cycle, follow flow chart. See Figure 9-5.

NOTE: If symptom or problem corresponds to one of the symptoms detailed on the following pages, proceed to that flow chart. (Diagnostic cycle chart check does not have to be made.)

Self-Diagnostic Routine

Entry: Follow the sequence given below.

1. Make sure loading door is closed.
2. Start in idle mode, all LED's (Light Emitting Diodes) off. See Figure 9-3.
3. Press SIGNAL VOLUME pad down and hold. See Figure 9-3.
4. Now press START pad down and release all pads when sequence starts. See Figure 9-3.
5. If unable to start routine, check loading door switch.

Exit: Do any of the following.

1. Press any pad.
2. Open loading door for four seconds.
3. Unplug washer.

NOTE:

1. This test routine will only light LED's (Light Emitting Diodes) pertaining to hardware model selected. The LED lights are located to the left of the SELECT CYCLE and OPTIONS pads. See Figure 9-3.
2. When last step in table is finished, routine sequence will repeat.
3. Each output is on for five seconds.

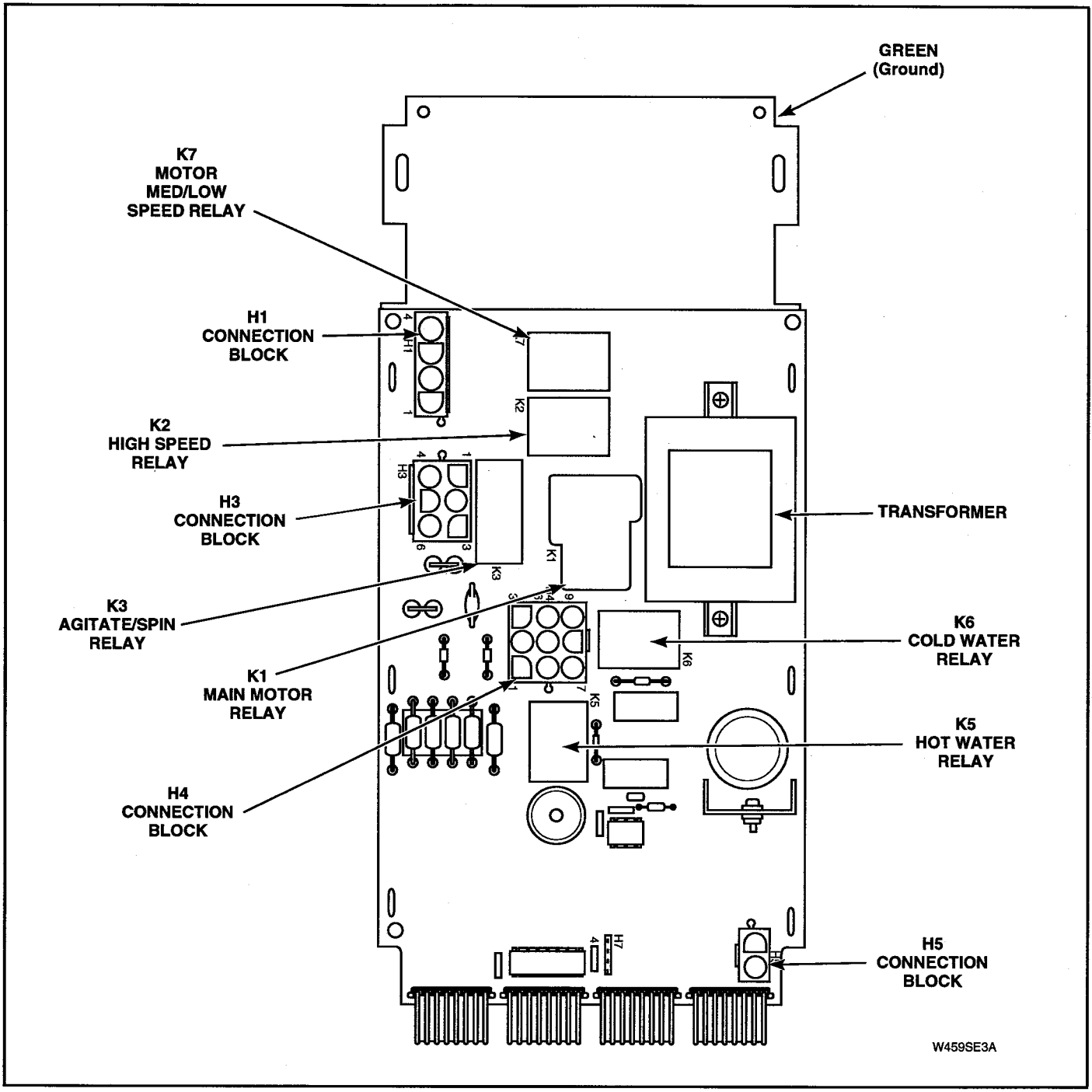

W459SE3A

**Connection Relay and Transformer Diagram
(Electronic Control)**

Figure 9-4



WARNING

To reduce the risk of electric shock, fire, explosion, serious injury or death:

- Disconnect electric power to the washer before servicing.
- Never start the washer with any guards/panels removed.
- Whenever ground wires are removed during servicing, these ground wires must be reconnected to ensure that the washer is properly grounded.

W003

Diagnostic Routine						
Time Display	Active LED's (Light Emitting Diodes)	Motor Direction	Motor Relay	Hot Water	Cold Water	Signal Volume
00	All On	High Agitate	K1	Off	Off	Off
05	All Off	High Agitate	K1	On	On	Off
10	All On	None	Off	Off	Off	Off
15	All Off	Med Agitate	K1, K2, K7	On	On	Off
20	All On	Med Agitate	K1, K2, K7	Off	Off	Off
25	All Off	None	Off	On	On	Off
30	All On	Low Agitate	K1, K2	Off	Off	Off
35	All Off	Low Agitate	K1, K2	On	On	Off
40	All On	None	Off	Off	Off	Off
45	All Off	High Spin	K1, K3	On	On	Off
50	All On	High Spin	K1, K3	Off	Off	Off
55	All Off	None	Off	On	On	Off
60	All On	Med Spin	K1, K2, K3, K7	Off	Off	Off
65	All Off	Med Spin	K1, K2, K3, K7	On	On	Off
70	All On	None	Off	Off	Off	Off
75	All Off	Low Spin	K1, K2, K3	On	On	Off
80	All On	Low Spin	K1, K2, K3	Off	Off	Off
85	All Off	None	Off	On	On	Lo
90	All On	None	Off	Off	Off	Med
95	All Off	None	Off	On	On	High

Figure 9-5



WARNING

To reduce the risk of electric shock, fire, explosion, serious injury or death:

- Disconnect electric power to the washer before servicing.
- Never start the washer with any guards/panels removed.
- Whenever ground wires are removed during servicing, these ground wires must be reconnected to ensure that the washer is properly grounded.

W003

6. FAILURE SYMPTOMS

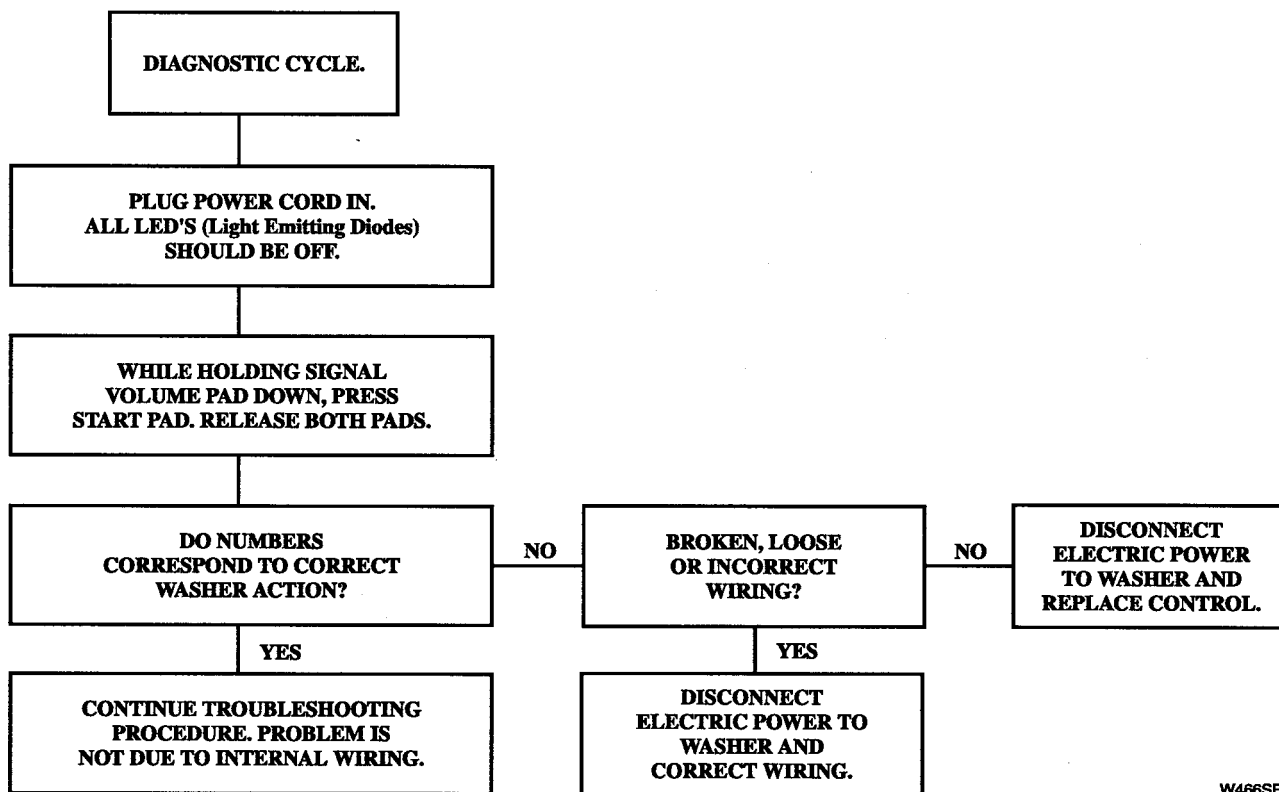

W466SE3A

NOTE: If, when trying to start Diagnostic Cycle, LED (Light Emitting Diodes) display flashes but does not start, check the following:

1. Is loading door closed?
2. Loading door switch operating properly:
3. Is motor correctly connected and is it not thermalled out?



WARNING

To reduce the risk of electric shock, fire, explosion, serious injury or death:

- Disconnect electric power to the washer before servicing.
- Never start the washer with any guards/panels removed.
- Whenever ground wires are removed during servicing, these ground wires must be reconnected to ensure that the washer is properly grounded.

W003

7. SYMPTOM: FLASHING DISPLAY

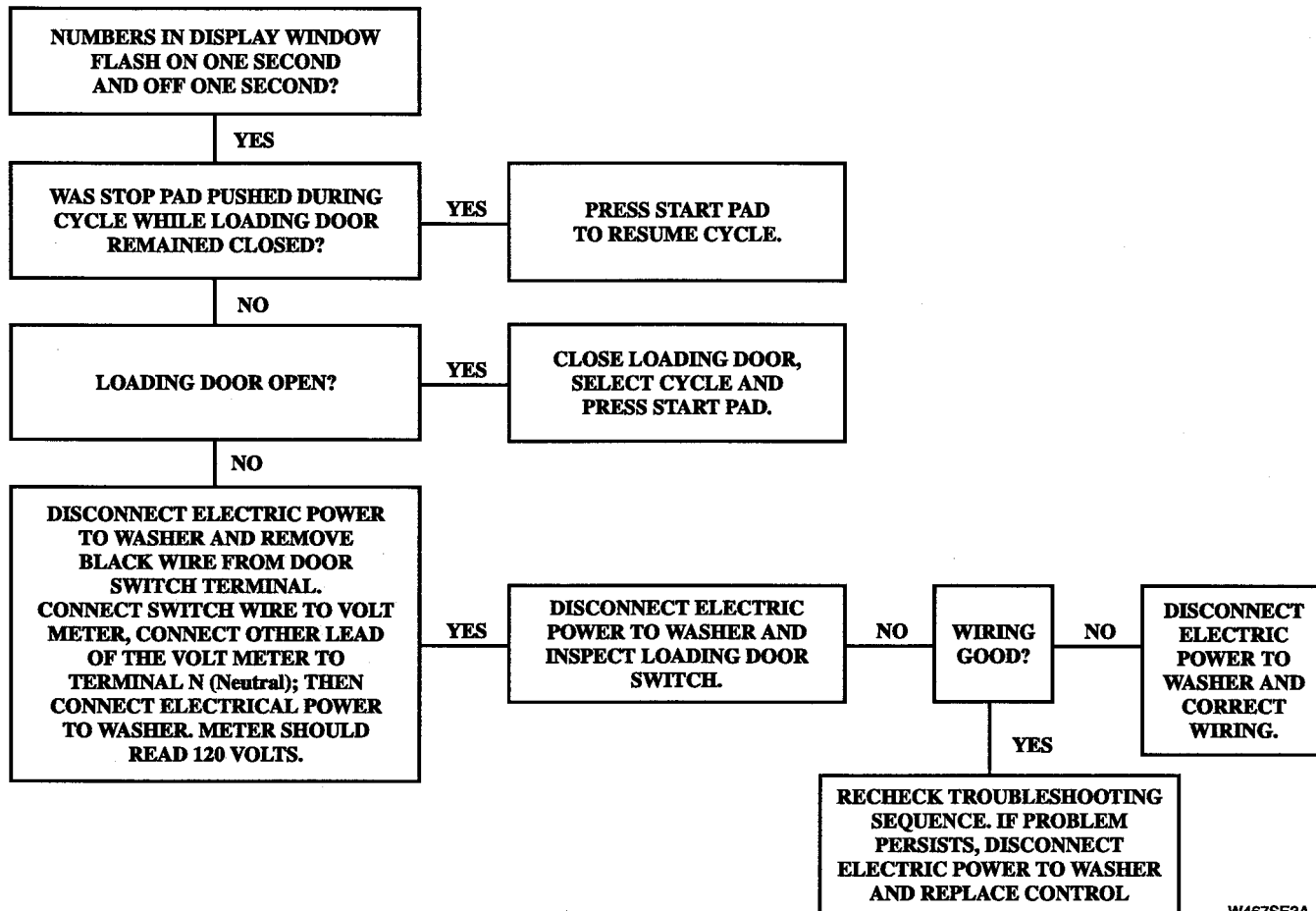

W467SE3A



WARNING

To reduce the risk of electric shock, fire, explosion, serious injury or death:

- Disconnect electric power to the washer before servicing.
- Never start the washer with any guards/panels removed.
- Whenever ground wires are removed during servicing, these ground wires must be reconnected to ensure that the washer is properly grounded.

W003

8. SYMPTOM: INDICATOR LED'S (LIGHT EMITTING DIODES) WILL NOT LIGHT WHEN SELECT CYCLE PAD IS PRESSED

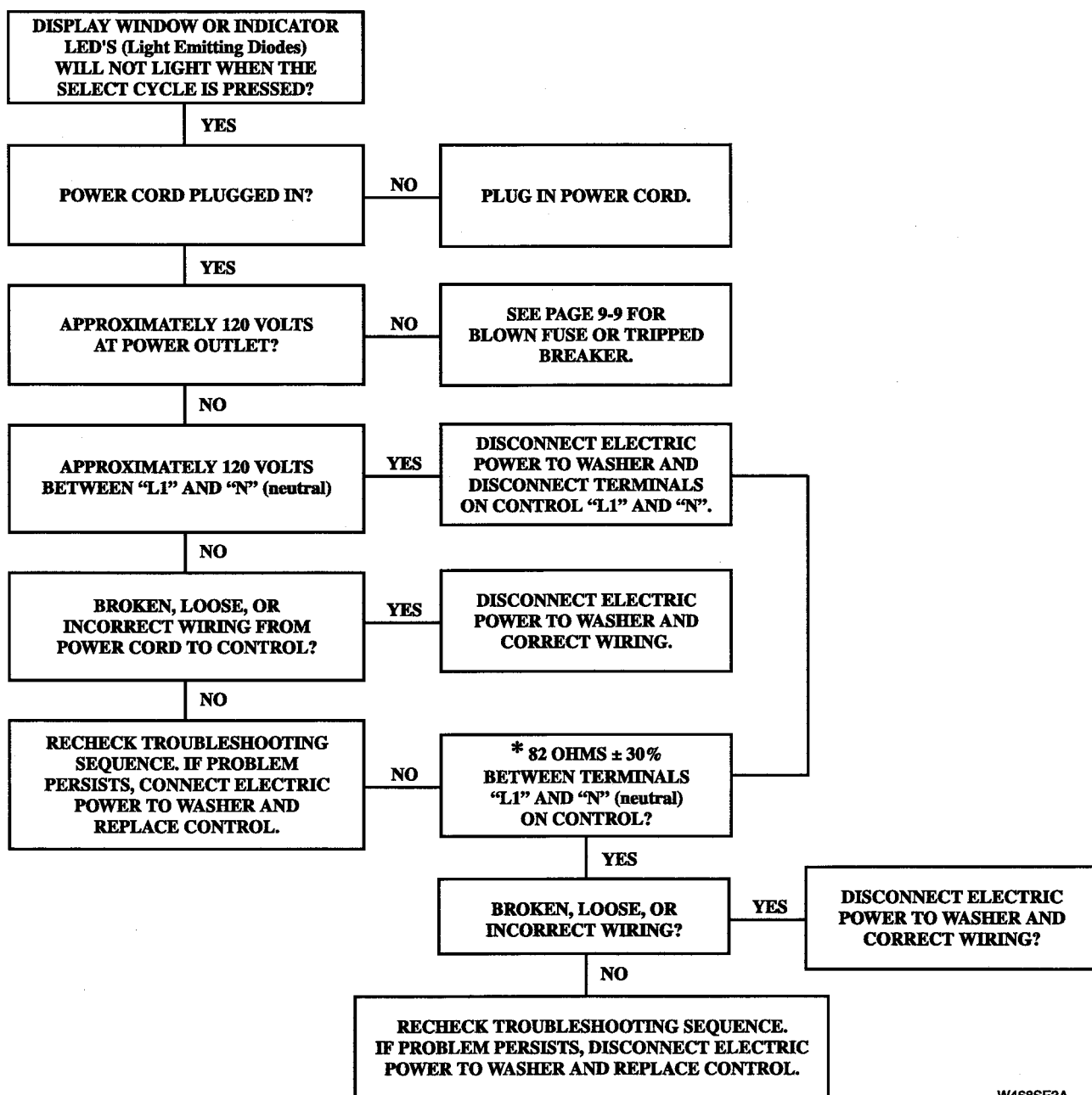

W468SE3A

* For precision, this measurement must be taken with a digital multi-meter set on 200 Ohm scale.

NOTE: If "ER" appears in window display, option is invalid and LED (Light Emitting Diodes) will not light. Refer to ERROR SINGLA in USE AND CARE MANUAL supplied with washer.



WARNING

To reduce the risk of electric shock, fire, explosion, serious injury or death:

- Disconnect electric power to the washer before servicing.
- Never start the washer with any guards/panels removed.
- Whenever ground wires are removed during servicing, these ground wires must be reconnected to ensure that the washer is properly grounded.

W003

9. SYMPTOM: TRIPPED CIRCUIT BREAKER OR BLOWN FUSE

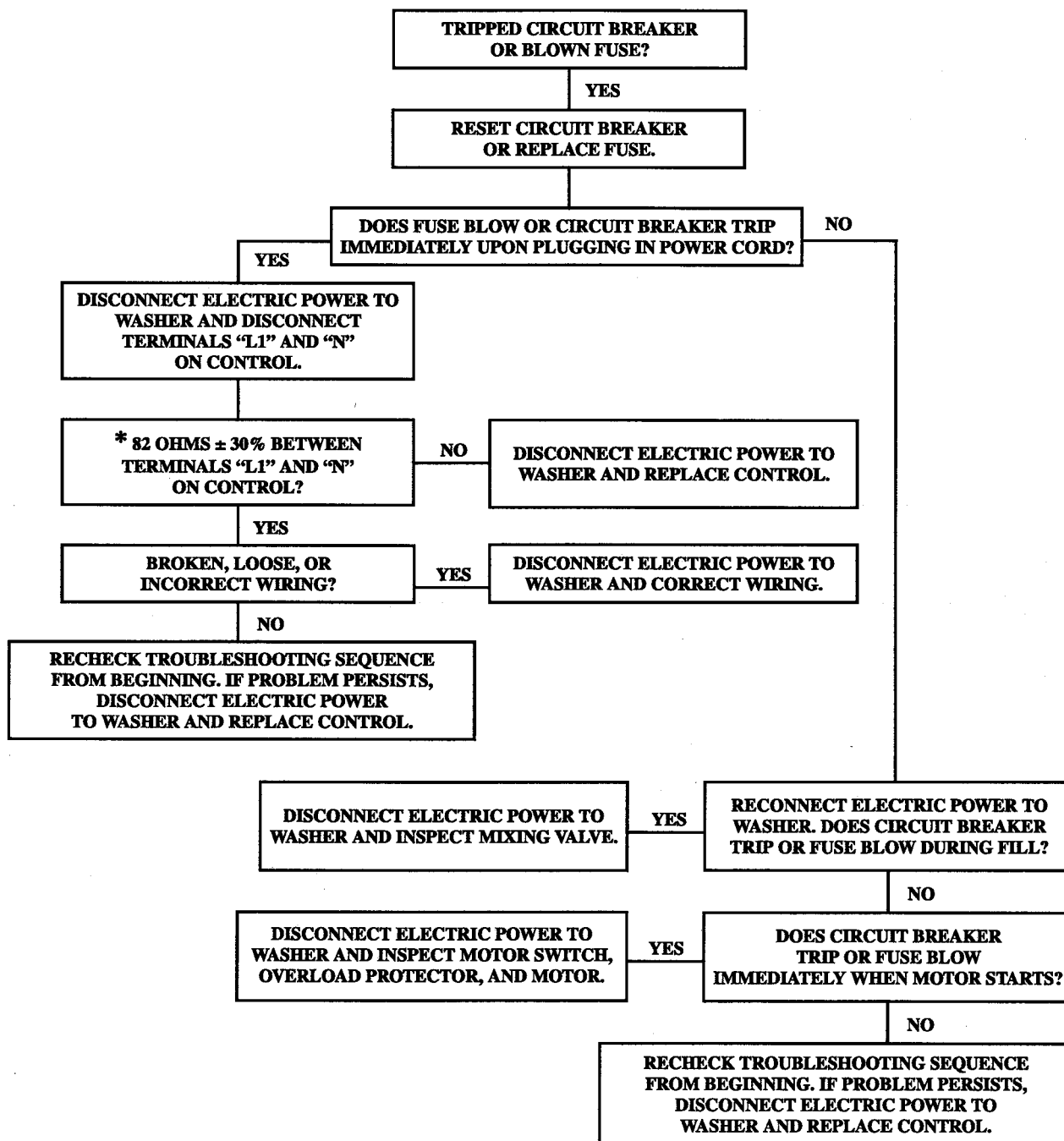

W469SE3A

* For precision, this measurement must be taken with a digital multi-meter set on 200 Ohm scale.



WARNING

To reduce the risk of electric shock, fire, explosion, serious injury or death:

- Disconnect electric power to the washer before servicing.
- Never start the washer with any guards/panels removed.
- Whenever ground wires are removed during servicing, these ground wires must be reconnected to ensure that the washer is properly grounded.

W003

10. SYMPTOM: WASHER WILL NOT FILL OR WRONG TEMPERATURE FILL

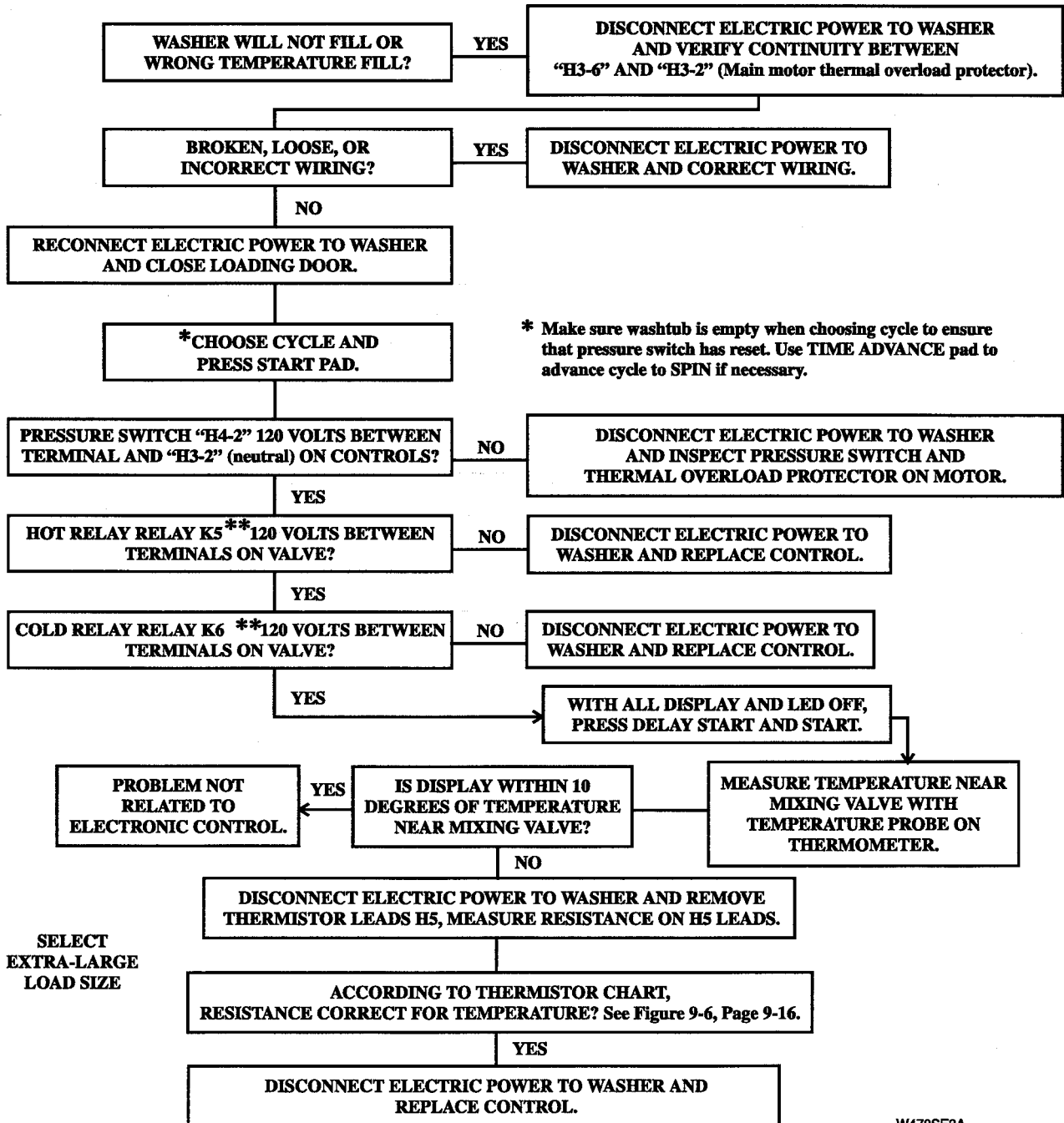

W470SE3A

**NOTE: Both hot water relay "K5" and cold water relay "K6" are energized for at least 30 seconds at start of a warm water fill. Only hot water relay "K5"

will be energized for hot water fill and only cold water relay "K6" will be energized for cold water fill.



WARNING

To reduce the risk of electric shock, fire, explosion, serious injury or death:

- Disconnect electric power to the washer before servicing.
- Never start the washer with any guards/panels removed.
- Whenever ground wires are removed during servicing, these ground wires must be reconnected to ensure that the washer is properly grounded.

W003

11. SYMPTOM: WASHER WILL NOT AGITATE PROPERLY

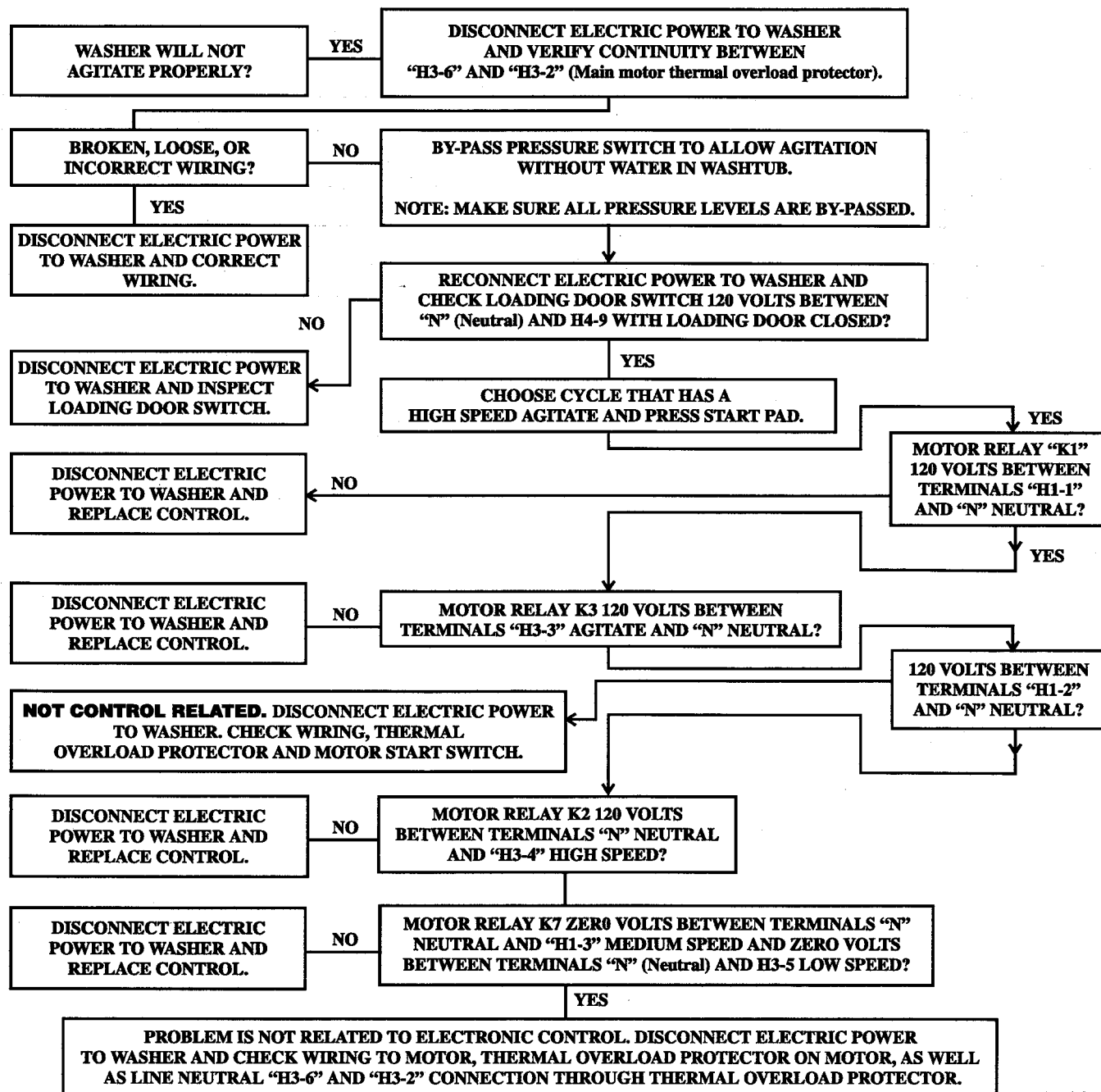

W471SE3A



WARNING

To reduce the risk of electric shock, fire, explosion, serious injury or death:

- Disconnect electric power to the washer before servicing.
- Never start the washer with any guards/panels removed.
- Whenever ground wires are removed during servicing, these ground wires must be reconnected to ensure that the washer is properly grounded.

W003

12. SYMPTOM: WASHER WILL NOT SPIN PROPERLY

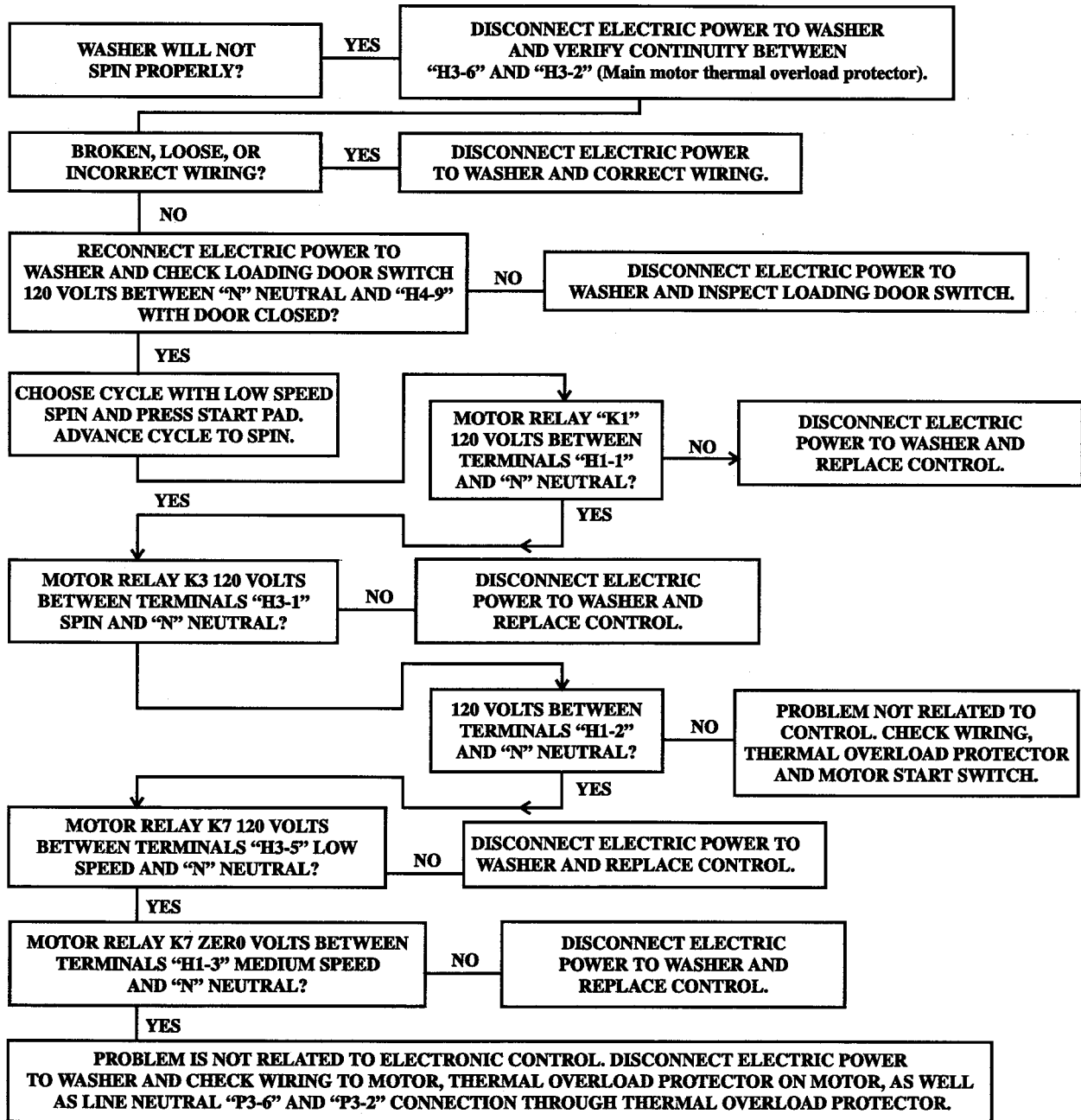

W472SE3A



WARNING

To reduce the risk of electric shock, fire, explosion, serious injury or death:

- Disconnect electric power to the washer before servicing.
- Never start the washer with any guards/panels removed.
- Whenever ground wires are removed during servicing, these ground wires must be reconnected to ensure that the washer is properly grounded.

W003

13. SYMPTOM: "bP" IN DISPLAY

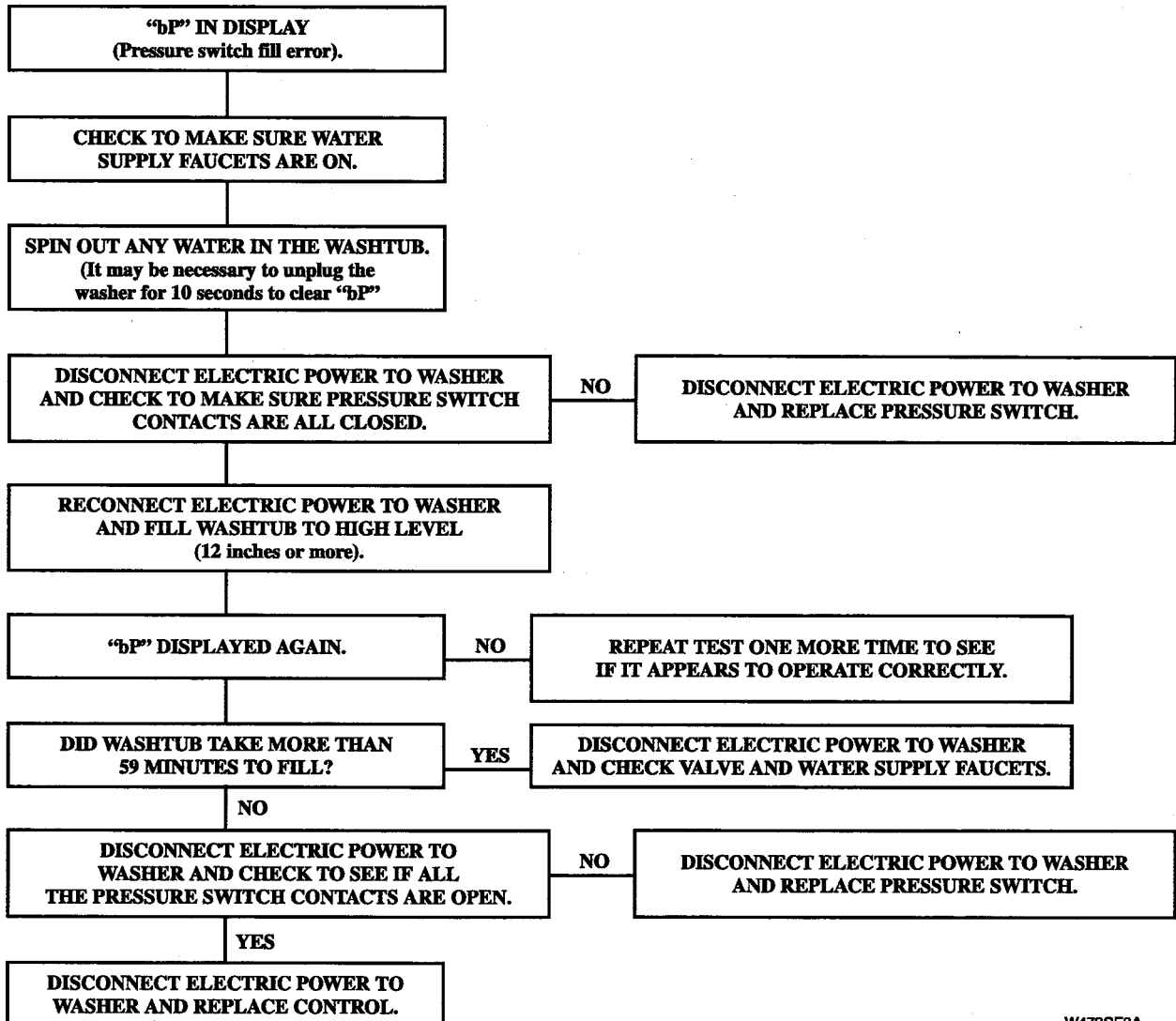

W473SE3A



WARNING

To reduce the risk of electric shock, fire, explosion, serious injury or death:

- Disconnect electric power to the washer before servicing.
- Never start the washer with any guards/panels removed.
- Whenever ground wires are removed during servicing, these ground wires must be reconnected to ensure that the washer is properly grounded.

W003

14. SYMPTOM: "rP" IN DISPLAY

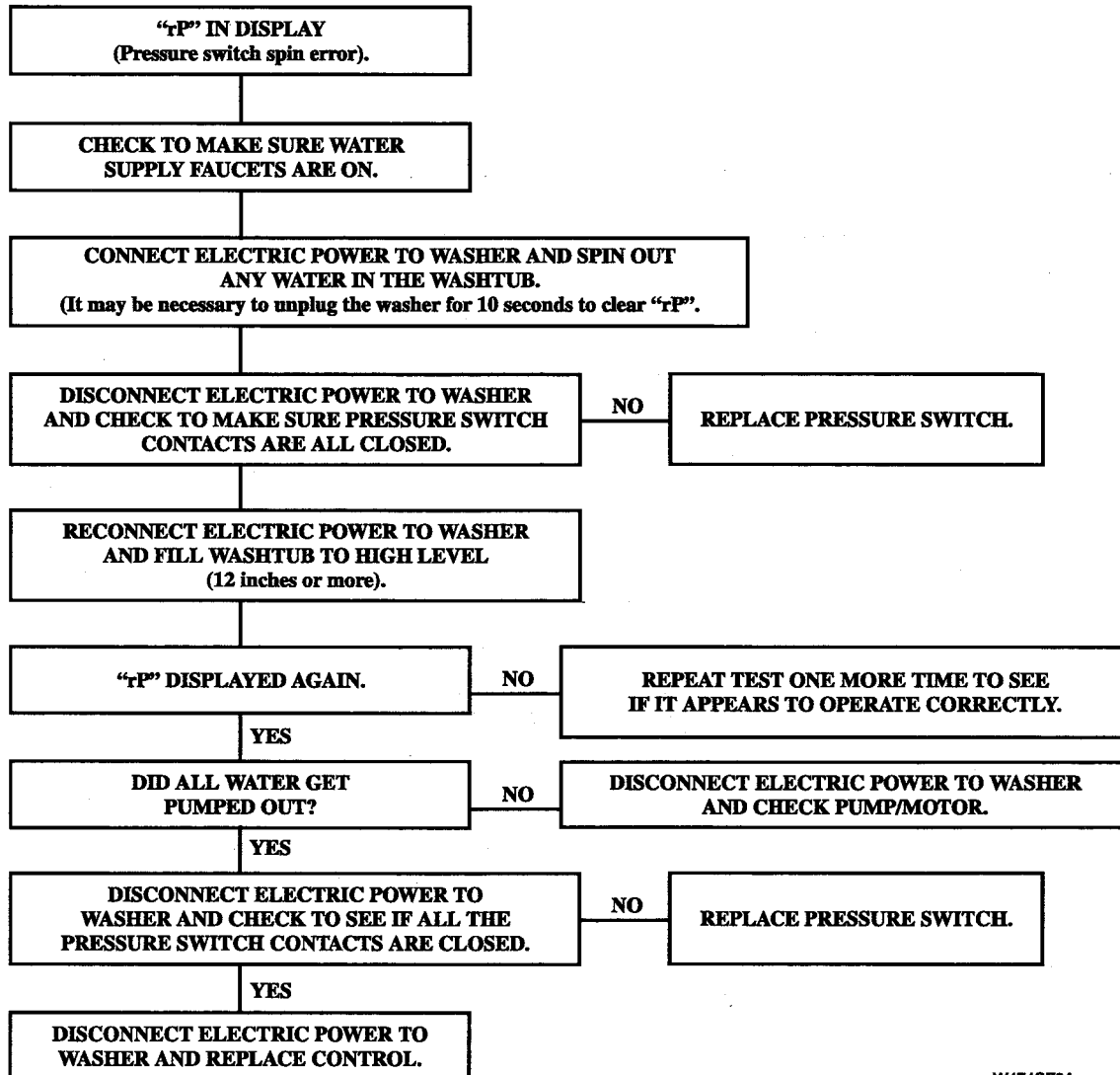

W474SE3A



WARNING

To reduce the risk of electric shock, fire, explosion, serious injury or death:

- Disconnect electric power to the washer before servicing.
- Never start the washer with any guards/panels removed.
- Whenever ground wires are removed during servicing, these ground wires must be reconnected to ensure that the washer is properly grounded.

W003

15. SYMPTOM: "oP" OR "SH" APPEARS IN TIME DISPLAY

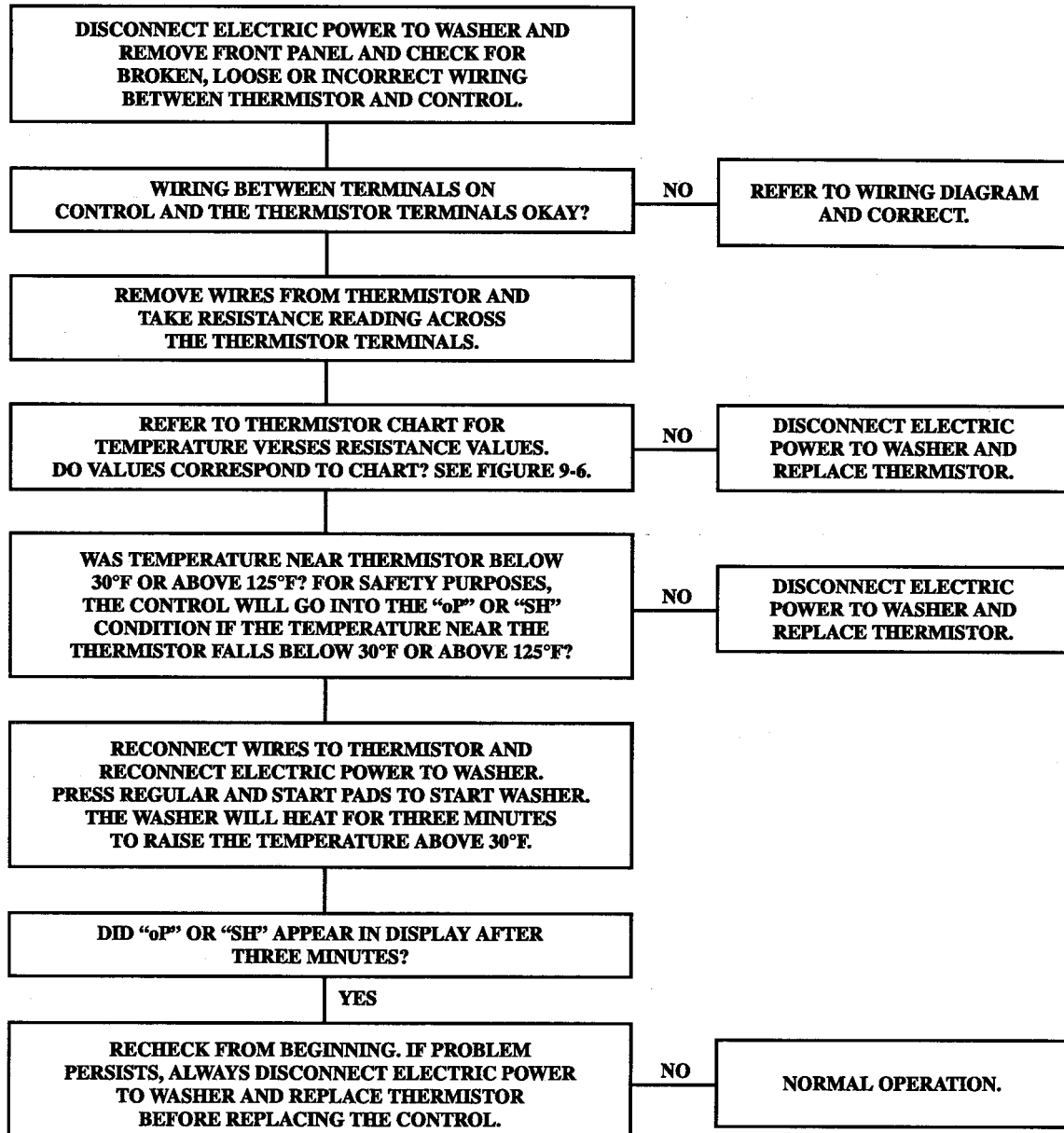

W475SE3A

NOTE: Thermistor located in the water inlet channel attached to the underside of the outer tub cover.



WARNING

To reduce the risk of electric shock, fire, explosion, serious injury or death:

- Disconnect electric power to the washer before servicing.
- Never start the washer with any guards/panels removed.
- Whenever ground wires are removed during servicing, these ground wires must be reconnected to ensure that the washer is properly grounded.

W003

Thermistor Chart

DEGREES (F)	RESISTANCE (Ohms)	DEGREES (F)	RESISTANCE (Ohms)	DEGREES: (F)	RESISTANCE (Ohms)
-5	501500	69	60900	143	11715
-4	485350	70	59400	144	11485
-3	469950	71	57950	145	11260
-2	455150	72	56550	146	11040
-1	440800	73	55150	147	10830
0	427000	74	53800	148	10620
1	413650	75	52500	149	10415
2	400800	76	51250	150	10210
3	388350	77	50000	151	100015
4	376350	78	48800	152	9825
5	364750	79	47630	153	9635
6	353600	80	46495	154	9455
7	342750	81	45385	155	9275
8	332300	82	44310	156	9100
9	322250	83	43265	157	8930
10	312500	84	42245	158	8760
11	303050	85	41250	159	8595
12	293950	86	40285	160	8435
13	285150	87	39345	161	8280
14	276650	88	38430	162	8125
15	268400	89	37540	163	7975
16	260450	90	36670	164	7830
17	252750	91	35825	165	7685
18	245300	92	35000	166	7545
19	238150	93	34200	167	7410
20	231150	94	33420	168	7275
21	224450	95	32660	169	7140
22	217900	96	31920	170	7010
23	211600	97	31195	171	6885
24	205500	98	30495	172	6760
25	199600	99	29810	173	6640
26	193900	100 (Nominal)	29140	174	6520
27	188350	101	28490	175	6405
28	183000	102	27855	176	6290
29	177850	103	27240	177	6180
30	172800	104	26635	178	6070
31	167950	105	26050	179	5960
32	163250	106	25475	180	5855
33	158700	107	24915	181	5755
34	154250	108	24370	182	5650



WARNING

To reduce the risk of electric shock, fire, explosion, serious injury or death:

- Disconnect electric power to the washer before servicing.
- Never start the washer with any guards/panels removed.
- Whenever ground wires are removed during servicing, these ground wires must be reconnected to ensure that the washer is properly grounded.

W003

Thermistor Chart

DEGREES (F)	RESISTANCE (Ohms)	DEGREES (F)	RESISTANCE (Ohms)	DEGREES: (F)	RESISTANCE (Ohms)
35	150000	109	23840	183	5555
36	145850	110	23325	184	5455
37	141850	111	22820	185	5360
38	137950	112	22325	186	5270
39	134150	113	21845	187	5175
40	130500	114	21375	188	5090
41	126950	115	20920	189	5000
42	123500	116	20475	190	4915
43	120200	117	20040	191	4831
44	116950	118	19615	192	4749
45	113800	119	19200	193	4668
46	110800	120	18795	194	4589
47	107850	121	18400	195	4511
48	104950	122	18015	196	4435
49	102200	123	17640	197	4361
50	99500	124	17270	198	4287
51	96900	125	16915	199	4216
52	94350	126	16565	200	4145
53	91900	127	16220	201	4077
54	89500	128	15885	202	4009
55	87150	129	15560	203	3943
56	84900	130	15245	204	3878
57	82750	131	14930	205	3812
58	80600	132	14630	206	3751
59	78550	133	14330	207	3690
60	76550	134	14045	208	3630
61	74600	135	13760	209	3571
62	72700	136	13485	210	3513
63	70850	137	13215	211	3456
64	69100	138	12950	212	3400
65	67350	139	12690	213	3346
66	65650	140	12440	214	3292
67	64050	141	12195	215	3239
68	62450	142	11950	216	3188

Figure 9-6

NOTE: Thermistor is located in the water inlet channel attached to the underside of the outer tub cover. As temperature decreases, resistance increases. As temperature increases, resistance decreases.

16. CONTROL REPLACEMENT

When a problem with electronic control is detected during diagnostic cycle or while making electrical tests we have discussed, control is replaced as a complete unit. Due to sensitivity of electronic control, careful handling is required. As a precautionary measure, we recommend using a grounded wrist strap when handling electronic control. Wrist strap, cord, and alligator clip are designed to carry away any electrostatic charge from your body and to direct charge to an available ground. By using this static protection device, potential electrostatic discharge problems associated with handling of electronic control will be minimized. Always handle electronic control by metal edges. If a wrist strap is not available, touch washer while it is plugged in before handling control to dissipate any charge.

To replace control, first unplug washer. Remove all of the wires connected to control and take out four screws securing control to control hood. When removing wires from control, hold down board near appropriate terminals, and disconnect wires using a pliers. Do not pull on wires.

New control is supplied in a special anti-static wrapping, and protected by anti-static foam. While holding metal edges, remove control from foam and wrapping. Lift the inoperative control off mounting bracket and place it on anti-static wrapping. Before positioning new control in control hood, peel off protective plastic coating from front side of control, then fasten control down with four screws. Following wiring diagram, reconnect wires to new control, then replace control hood.

IMPORTANT: It is important to take care when handling original control. It must be carefully placed in anti-static wrapping and anti-static foam which was removed from new control. A copy of the replacement report that is supplied with the replacement control, must be completely filled out and returned with the old control. Warranty credit will not be issued if control is not wrapped properly.

SECTION 10

Internal Wiring of Washer Motor Switch



WARNING

To reduce the risk of electric shock, fire, explosion, serious injury or death:

- Disconnect electric power to the washer before servicing.
- Never start the washer with any guards/panels removed.
- Whenever ground wires are removed during servicing, these ground wires must be reconnected to ensure that the washer is properly grounded.

W003

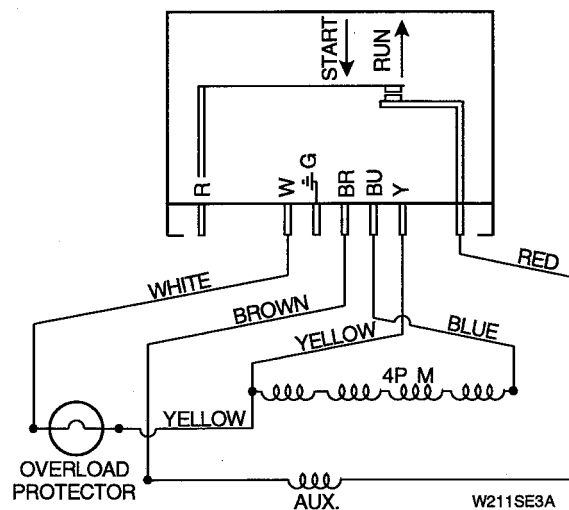
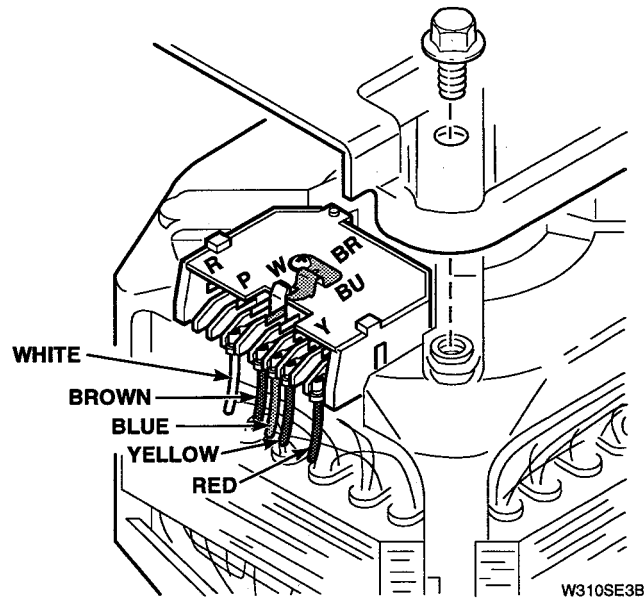

MOTOR ASSEMBLY
(1 Speed Motors)



WARNING

To reduce the risk of electric shock, fire, explosion, serious injury or death:

- Disconnect electric power to the washer before servicing.
- Never start the washer with any guards/panels removed.
- Whenever ground wires are removed during servicing, these ground wires must be reconnected to ensure that the washer is properly grounded.

W003

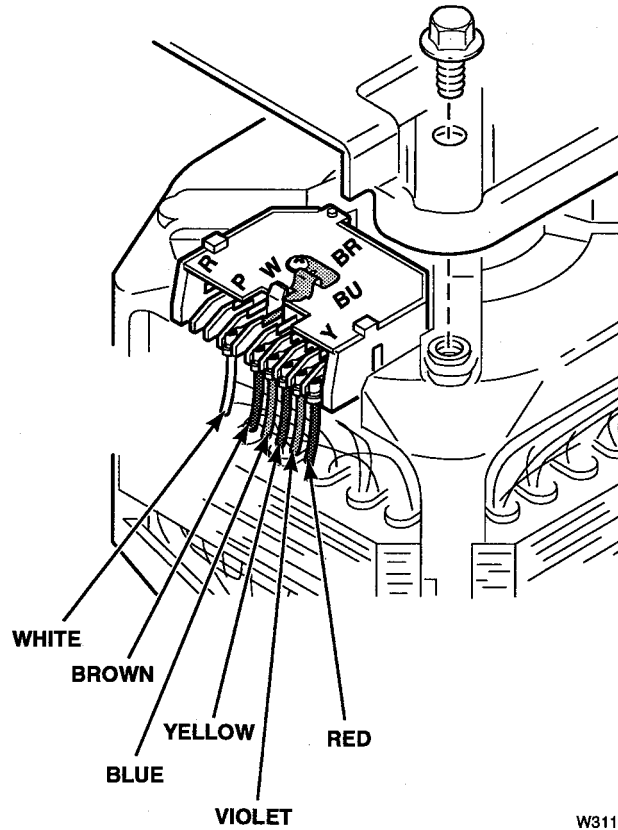

W311SE3C

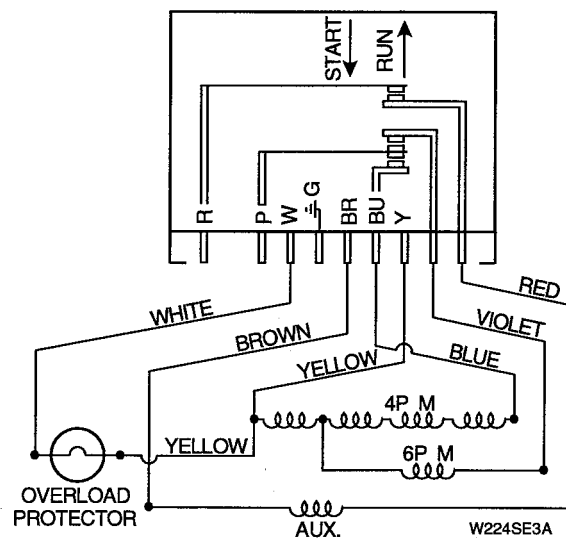

MOTOR ASSEMBLY
(2 Speed Motors)



WARNING

To reduce the risk of electric shock, fire, explosion, serious injury or death:

- Disconnect electric power to the washer before servicing.
- Never start the washer with any guards/panels removed.
- Whenever ground wires are removed during servicing, these ground wires must be reconnected to ensure that the washer is properly grounded.

W003

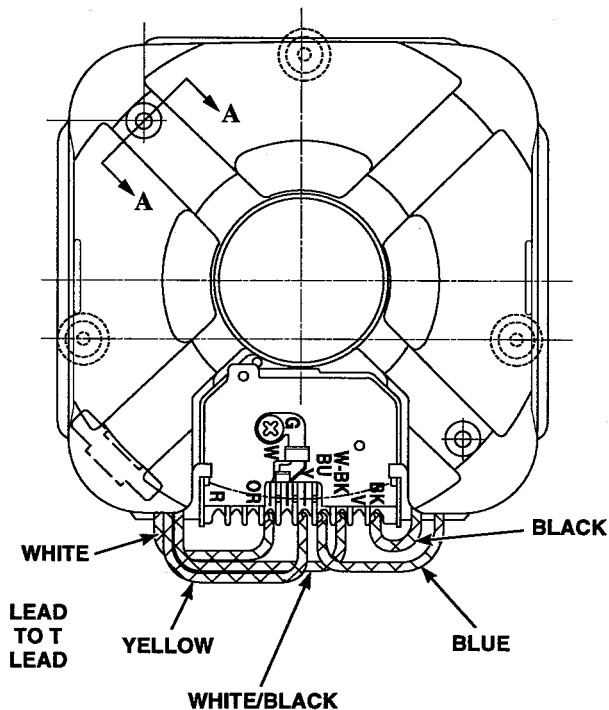

W406SE3A

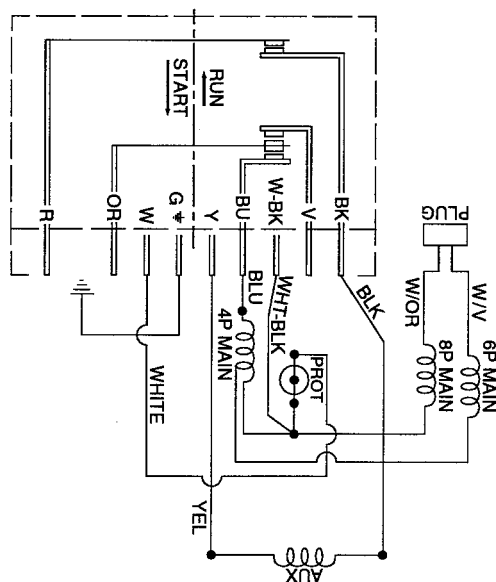

W405SE3A

MOTOR ASSEMBLY (3 Speed Motors)

SECTION 11

Wiring Diagrams

WARNING
 Failure to install, maintain, and/or operate this machine according to the manufacturer's instructions may result in conditions which can produce bodily injury and/or property damage.

W030

CONNECTION DIAGRAM

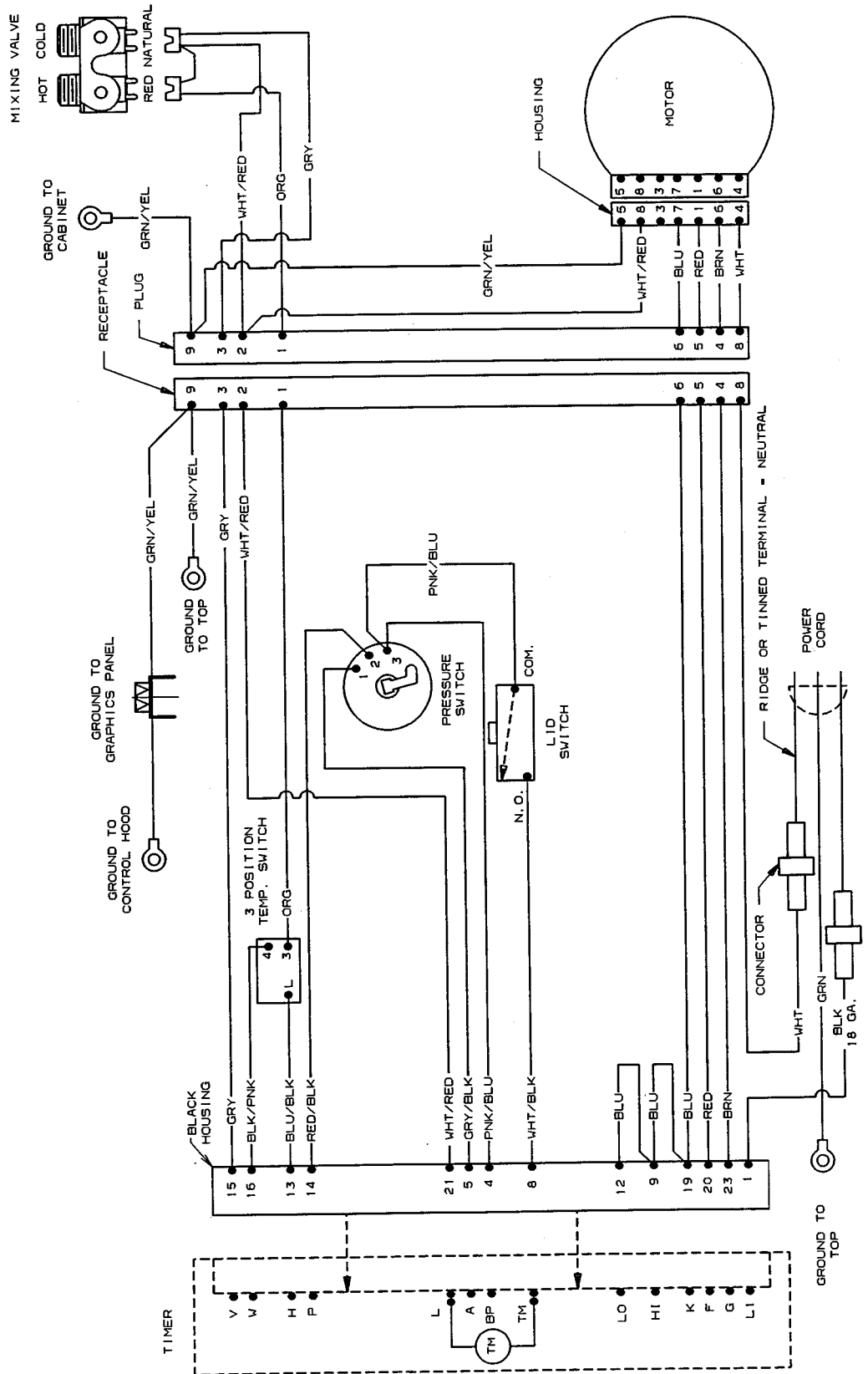

MODELS LWA10A* AND LWA20A*

SCHEMATIC

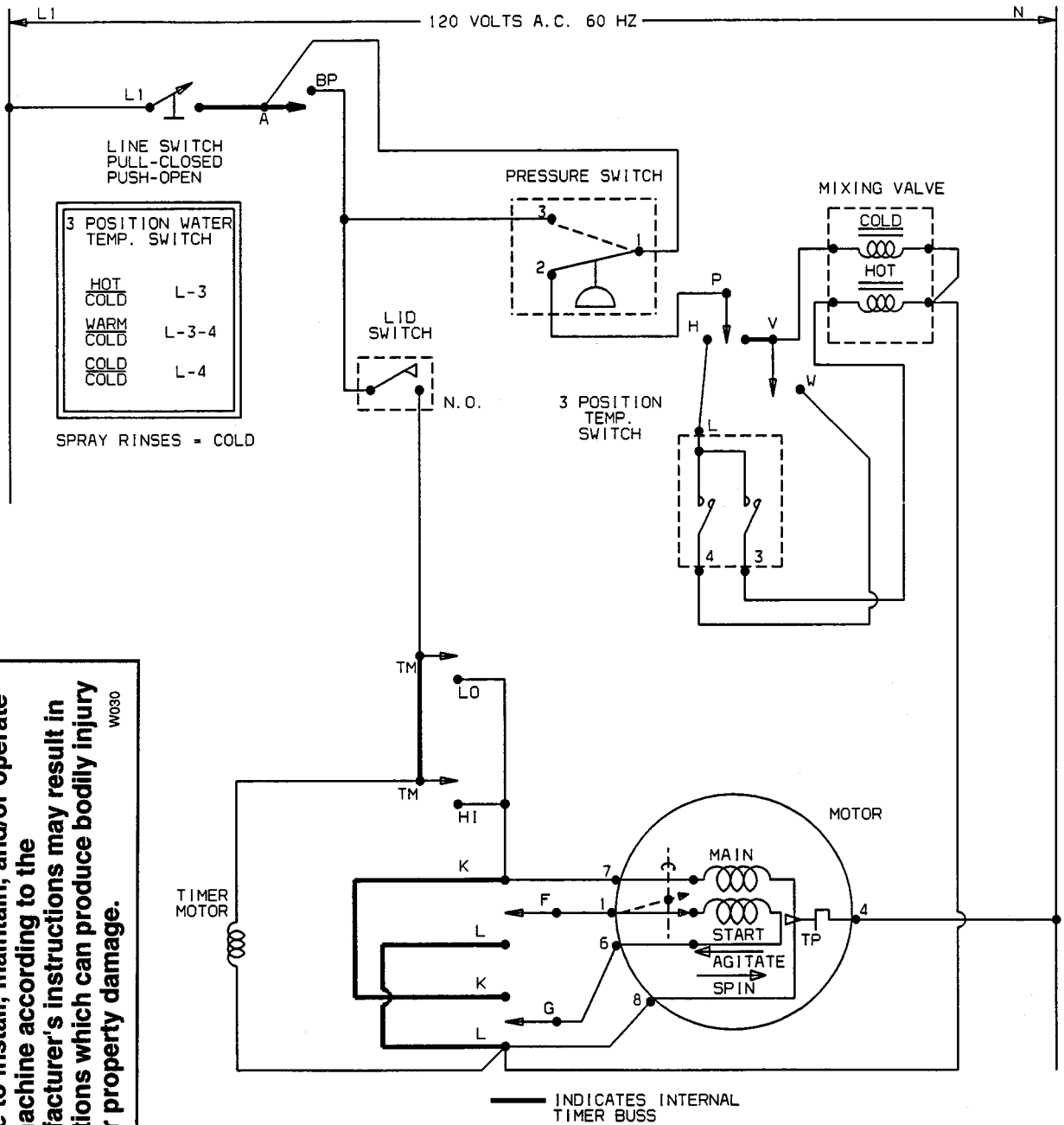

WARNING

Failure to install, maintain, and/or operate this machine according to the manufacturer's instructions may result in conditions which can produce bodily injury and/or property damage.

W030

MODELS LWA10A* AND LWA20A*

WARNING
 Failure to install, maintain, and/or operate this machine according to the manufacturer's instructions may result in conditions which can produce bodily injury and/or property damage.
 W030

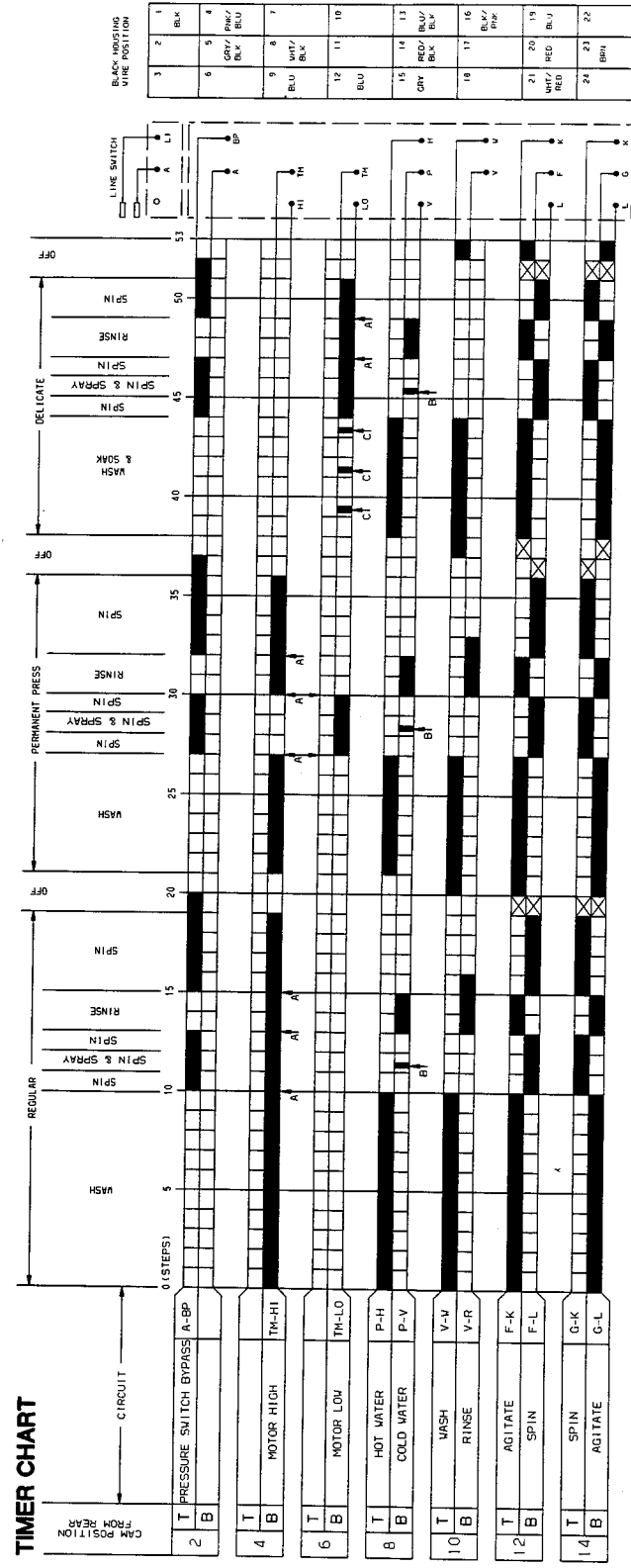

MODELS LWA10A* AND LWA20A*

WARNING
 Failure to install, maintain, and/or operate this machine according to the manufacturer's instructions may result in conditions which can produce bodily injury and/or property damage.

W030

CONNECTION DIAGRAM

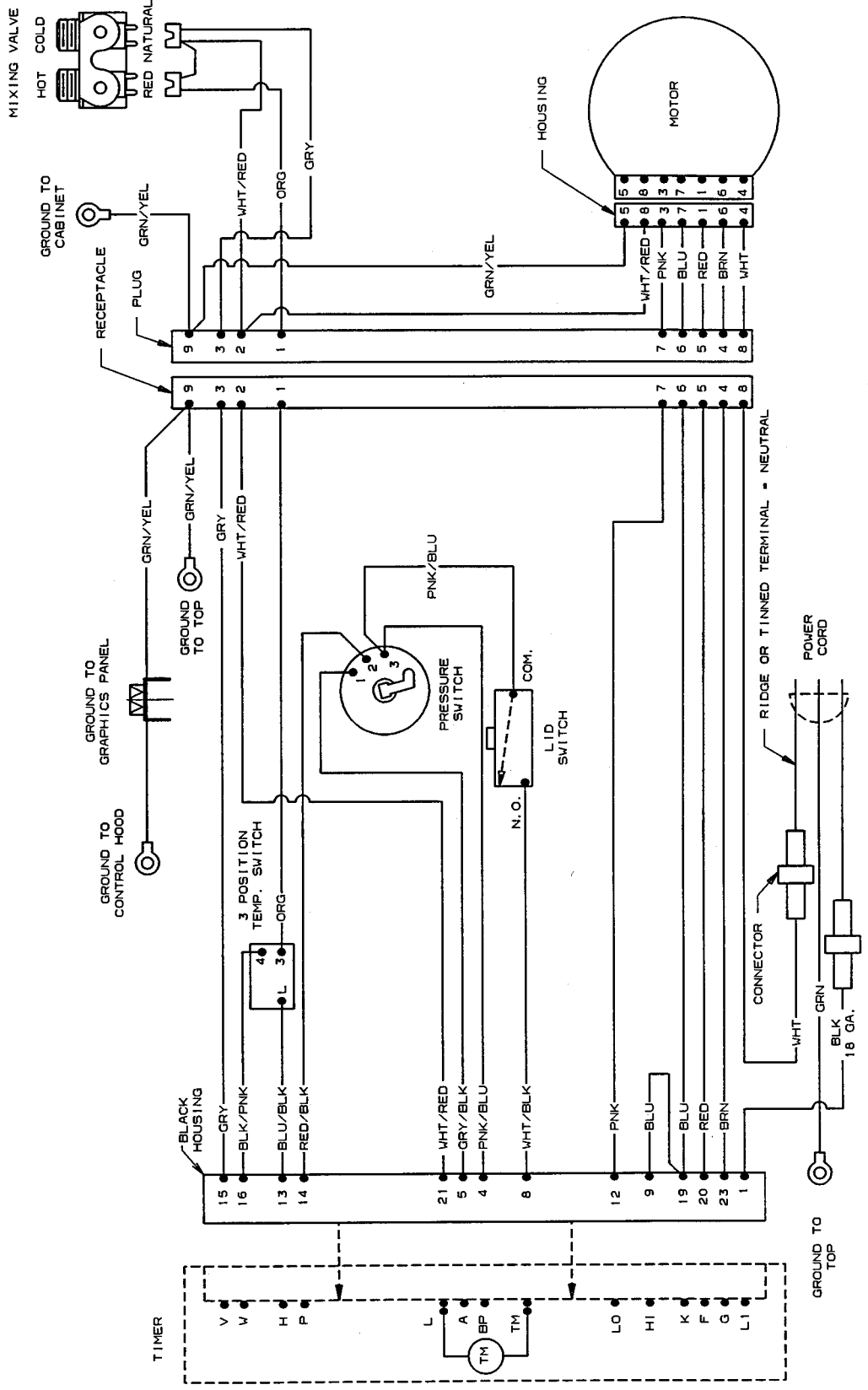

MODELS LWA05A*, LWA18A*, LWA30A*, LWA30B* LWA40A* LWC05A*, LWC07A*, LWC18A, LWC30A*, LWC40A*, LWD27A*, LWA27B*, LWA35A*, AND LWA37A*

SCHEMATIC

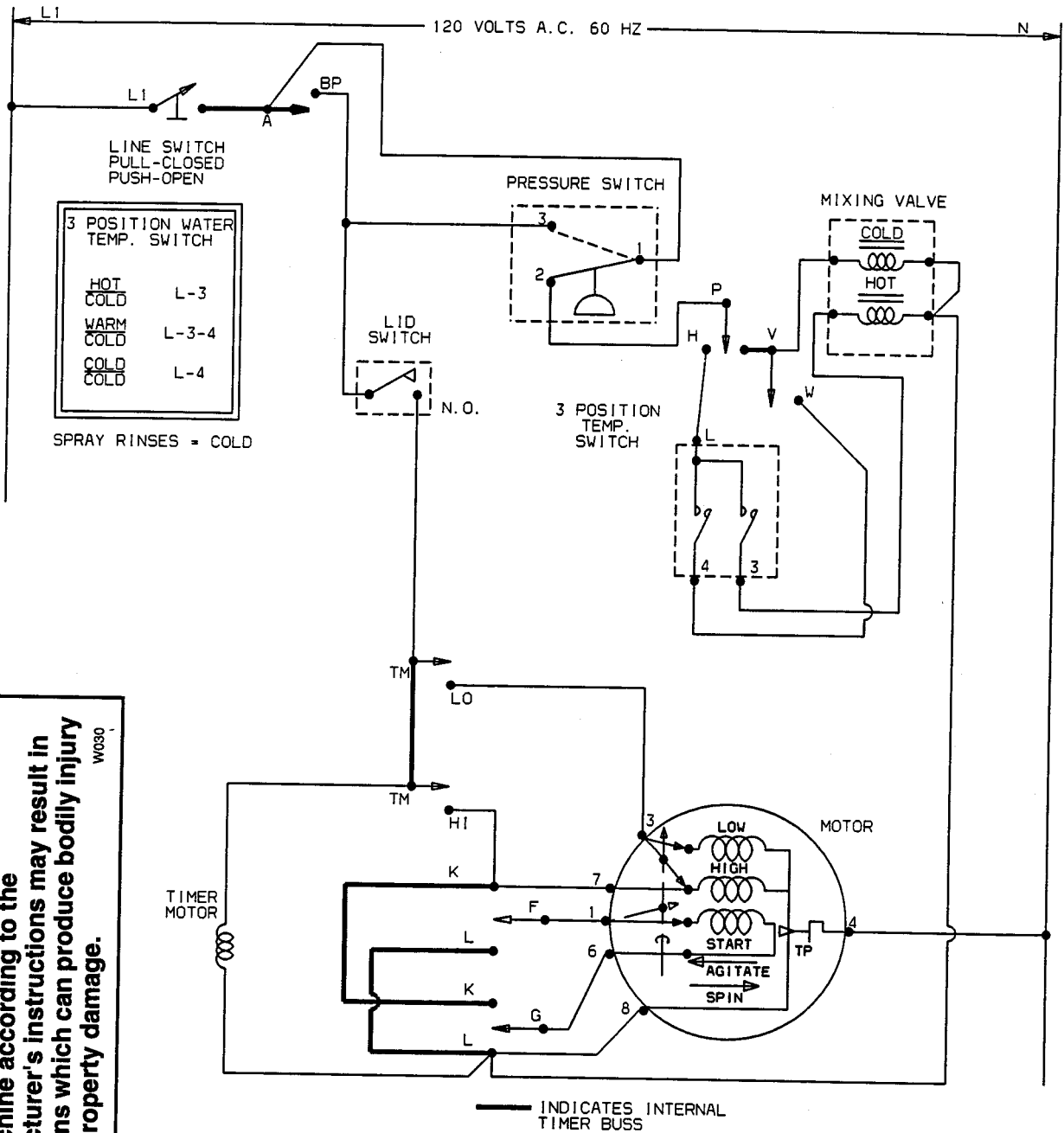

WARNING

Failure to install, maintain, and/or operate this machine according to the manufacturer's instructions may result in conditions which can produce bodily injury and/or property damage.

W030

MODELS LWA05A*, LWA18A*, LWA30A*, LWA30B* LWA40A* LWC05A*, LWC07A*, LWC18A, LWC30A*, LWC40A*, LWD27A*, LWA27B*, LWA35A*, AND LWA37A*

WARNING

Failure to install, maintain, and/or operate this machine according to the manufacturer's instructions may result in conditions which can produce bodily injury and/or property damage.

W030

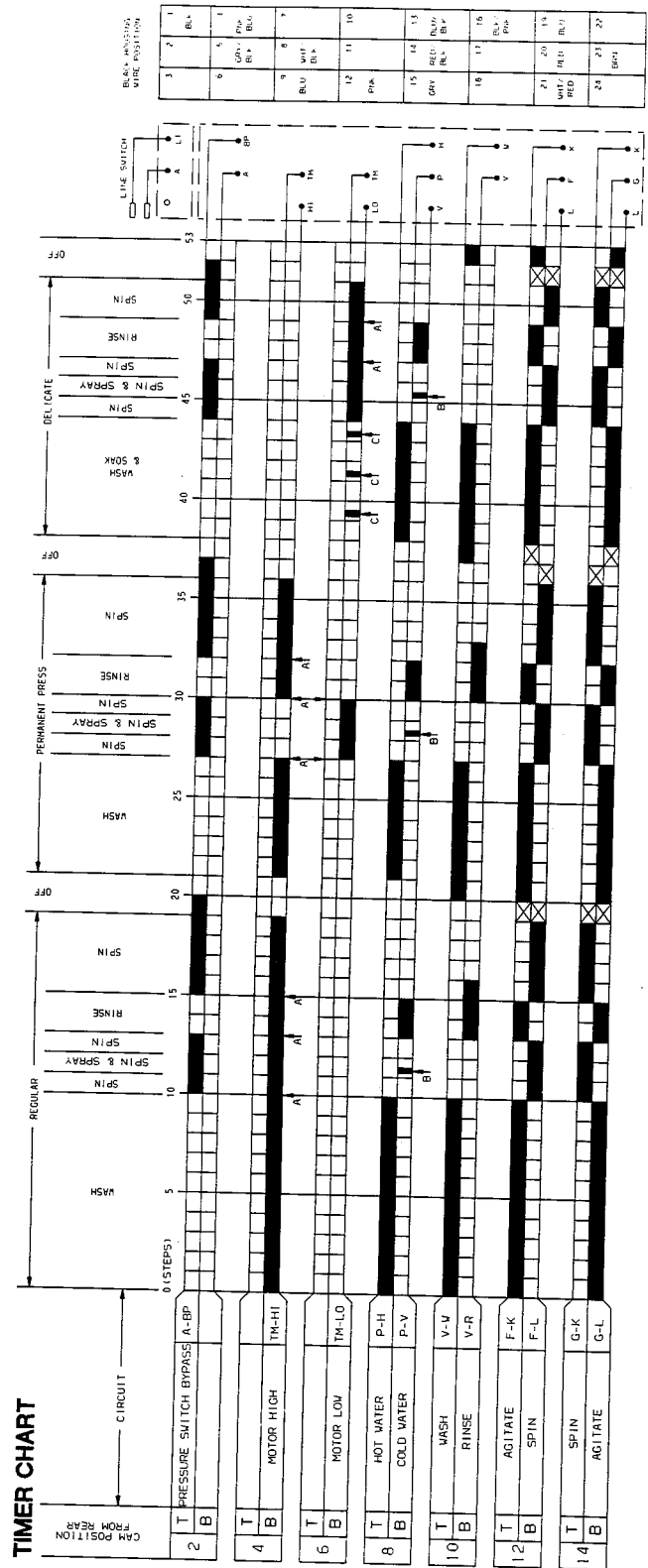

MODELS LWA05A*, LWA18A*, LWA30A*, LWA30B* LWA40A* LWC05A*, LWC07A*, LWC18A, LWC30A*, LWC40A*, LWD27A*, LWA27B*, LWA35A*, AND LWA37A*

WARNING
 Failure to install, maintain, and/or operate this machine according to the manufacturer's instructions may result in conditions which can produce bodily injury and/or property damage.

W030

CONNECTION DIAGRAM

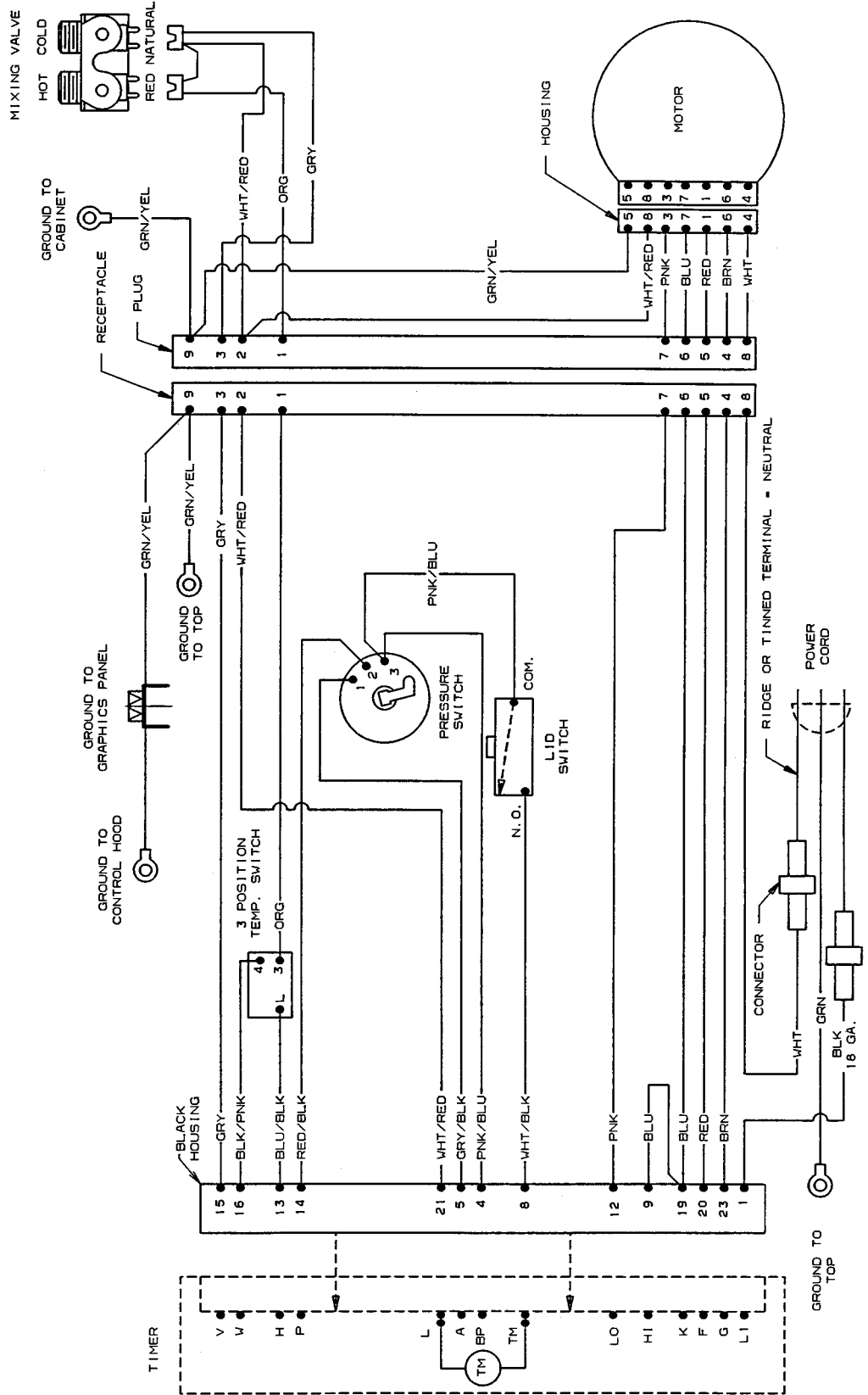

MODELS LWD40A *

SCHEMATIC

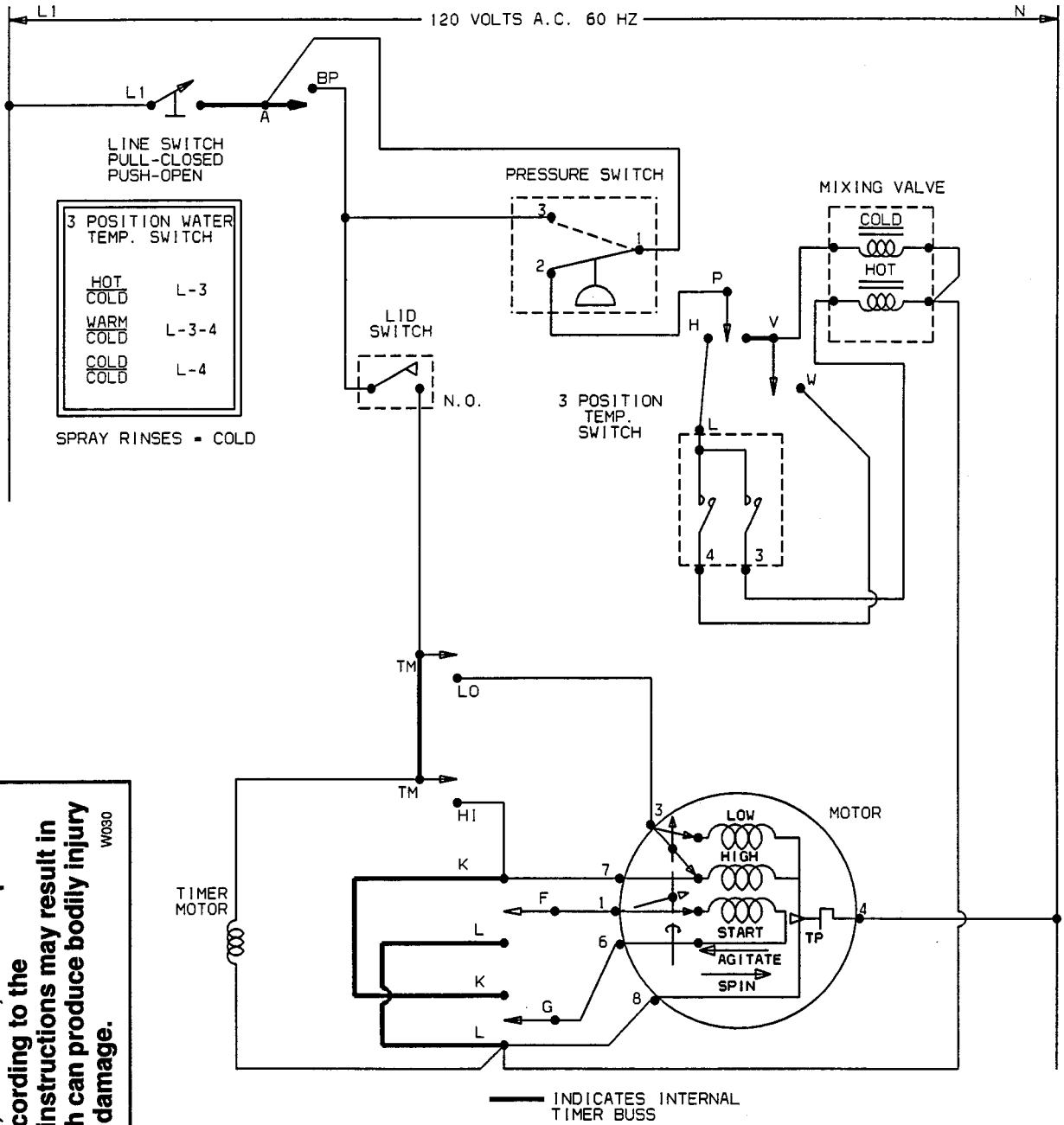

WARNING

Failure to install, maintain, and/or operate this machine according to the manufacturer's instructions may result in conditions which can produce bodily injury and/or property damage.

W030

MODELS LWD40A*

WARNING
 Failure to install, maintain, and/or operate
 this machine according to the
 manufacturer's instructions may result in
 conditions which can produce bodily injury
 and/or property damage.
 W030

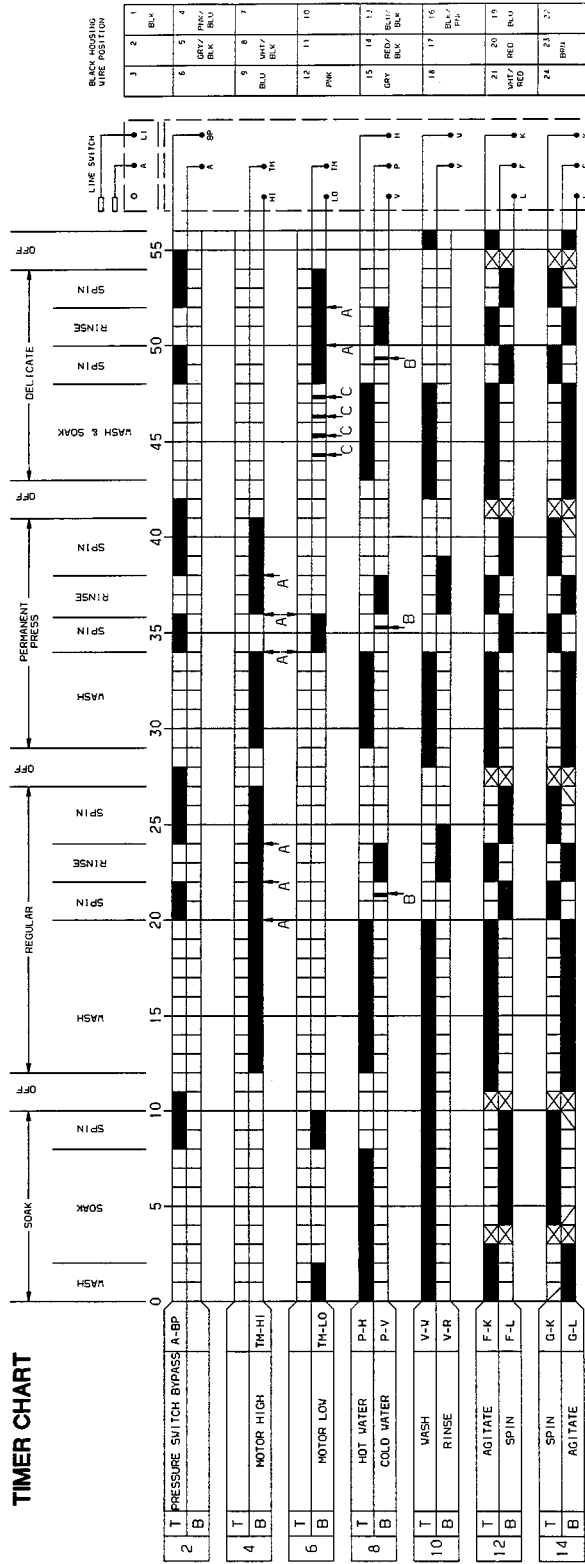

MODELS LWD040A*



WARNING

Failure to install, maintain, and/or operate this machine according to the manufacturer's instructions may result in conditions which can produce bodily injury and/or property damage.

W030

CONNECTION DIAGRAM

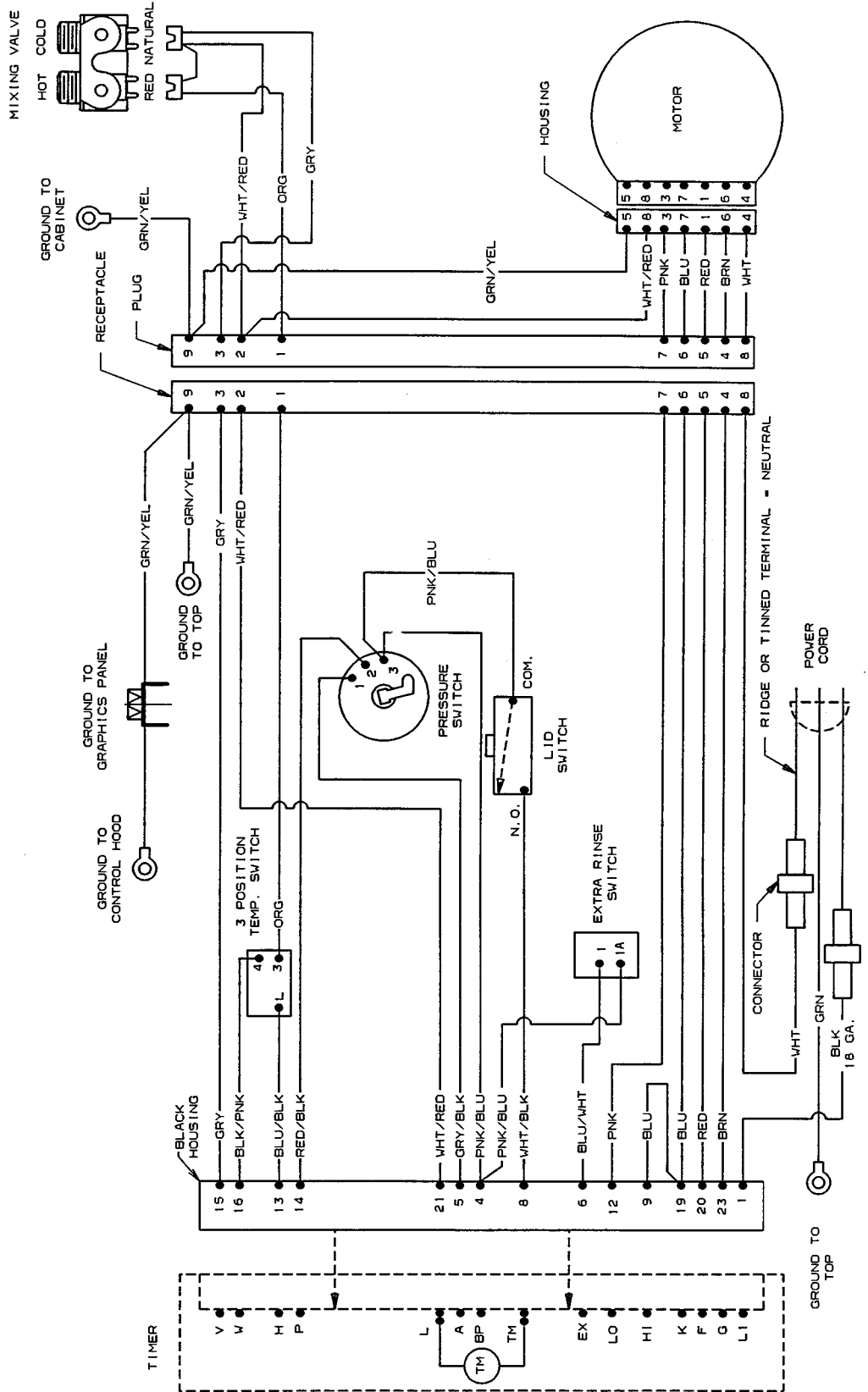

MODELS LWA50A*, AND LWC50A*

SCHEMATIC

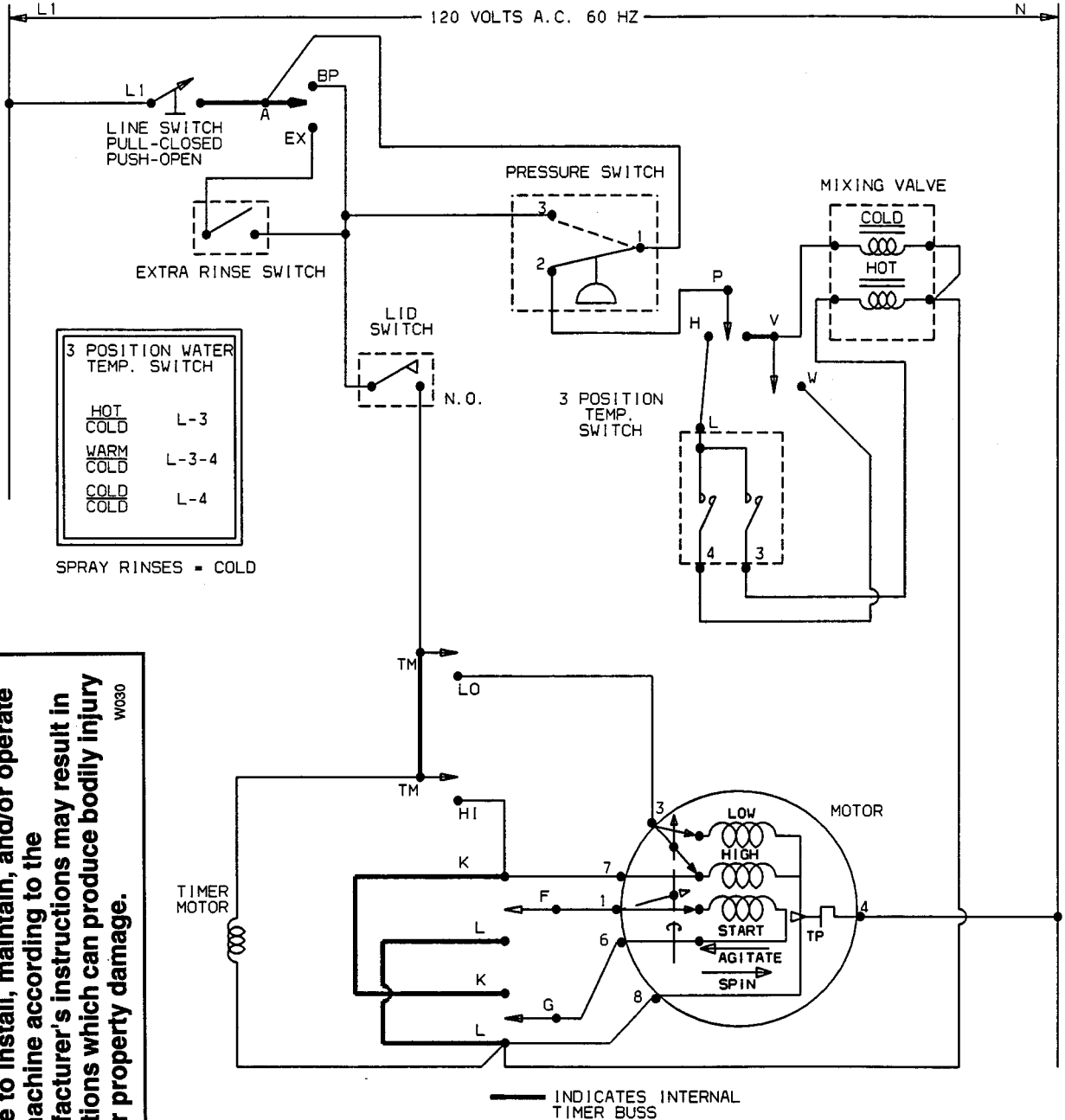

WARNING

Failure to install, maintain, and/or operate this machine according to the manufacturer's instructions may result in conditions which can produce bodily injury and/or property damage.

W030

MODELS LWA50A*, AND LWC50A*

WARNING
 Failure to install, maintain, and/or operate
 this machine according to the
 manufacturer's instructions may result in
 conditions which can produce bodily injury
 and/or property damage.

W030

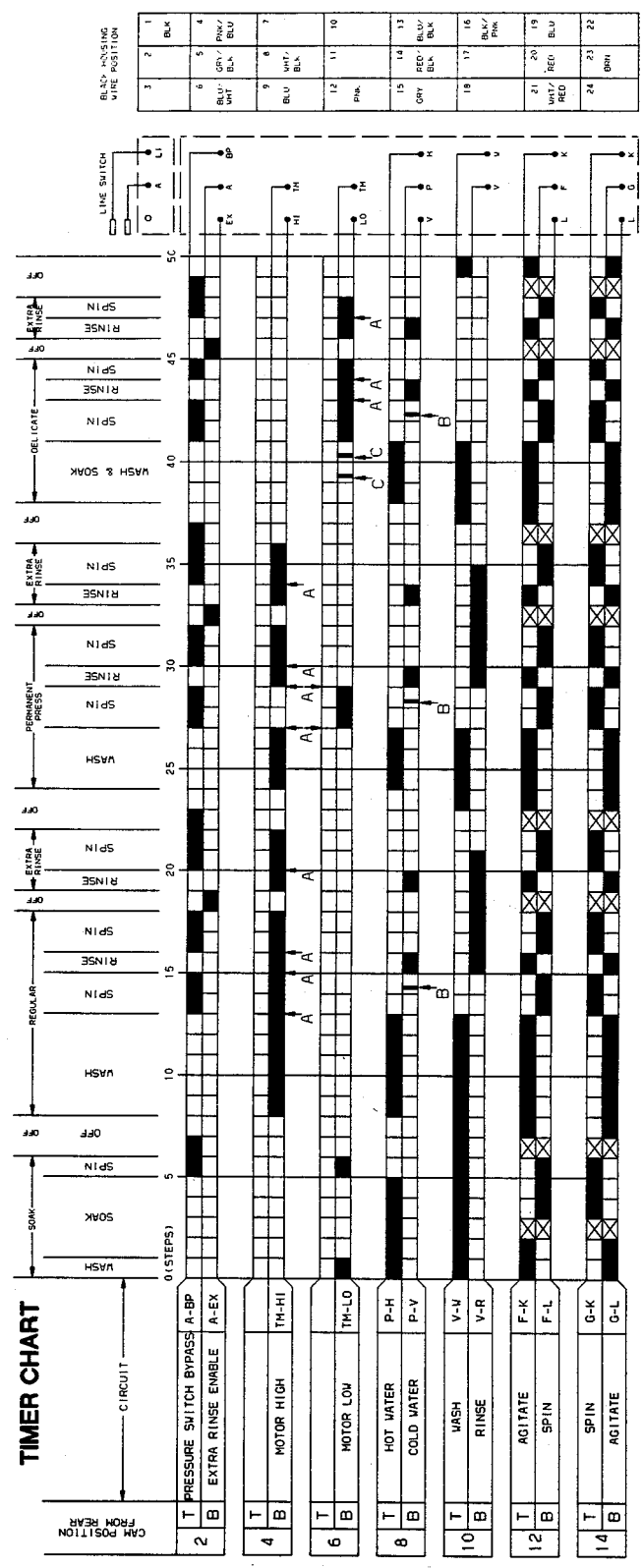

MODELS LWA50A*, AND LWC50A*

WARNING
 Failure to install, maintain, and/or operate this machine according to the manufacturer's instructions may result in conditions which can produce bodily injury and/or property damage.

W030

CONNECTION DIAGRAM

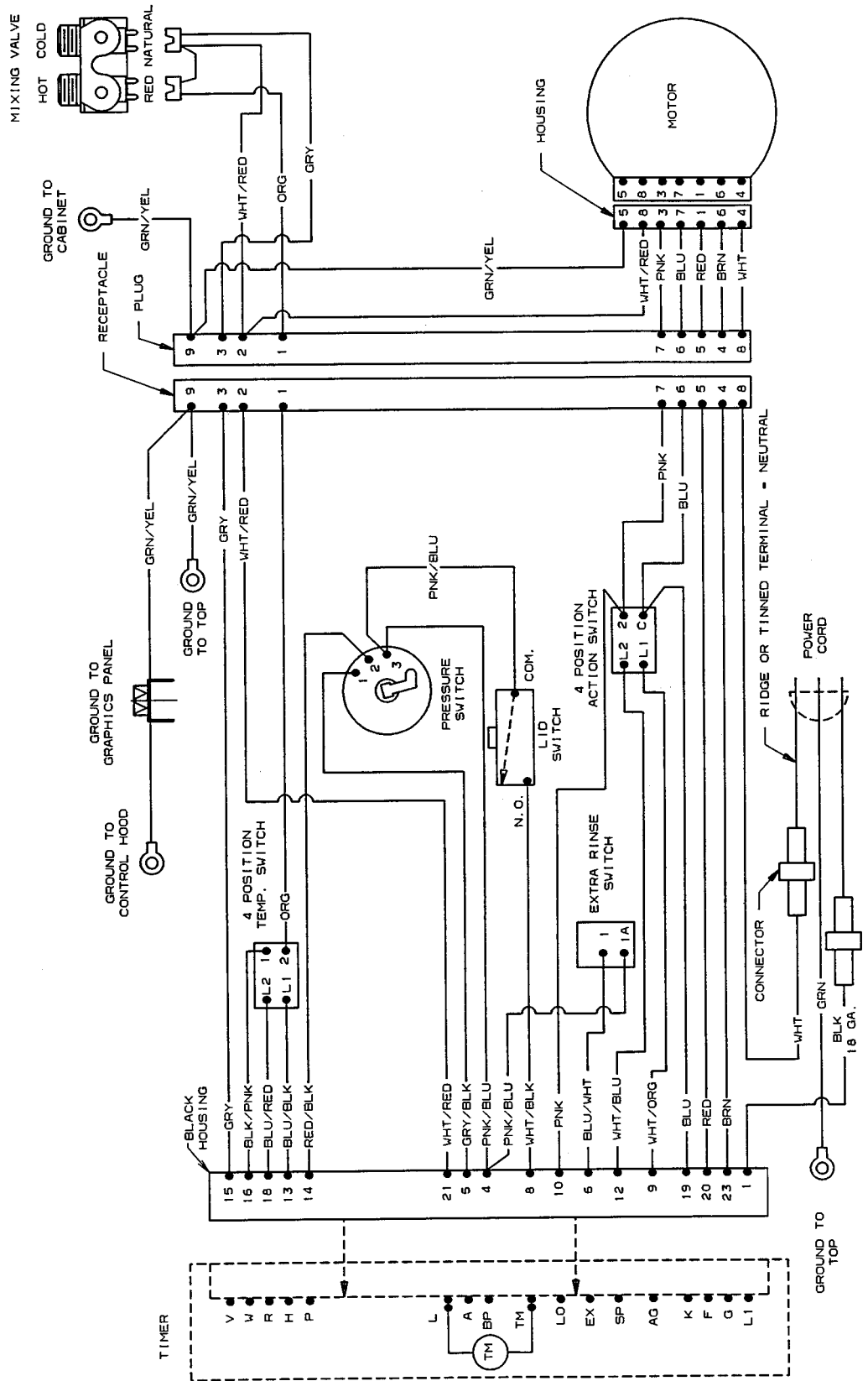

MODEL LWA60A *

SCHEMATIC

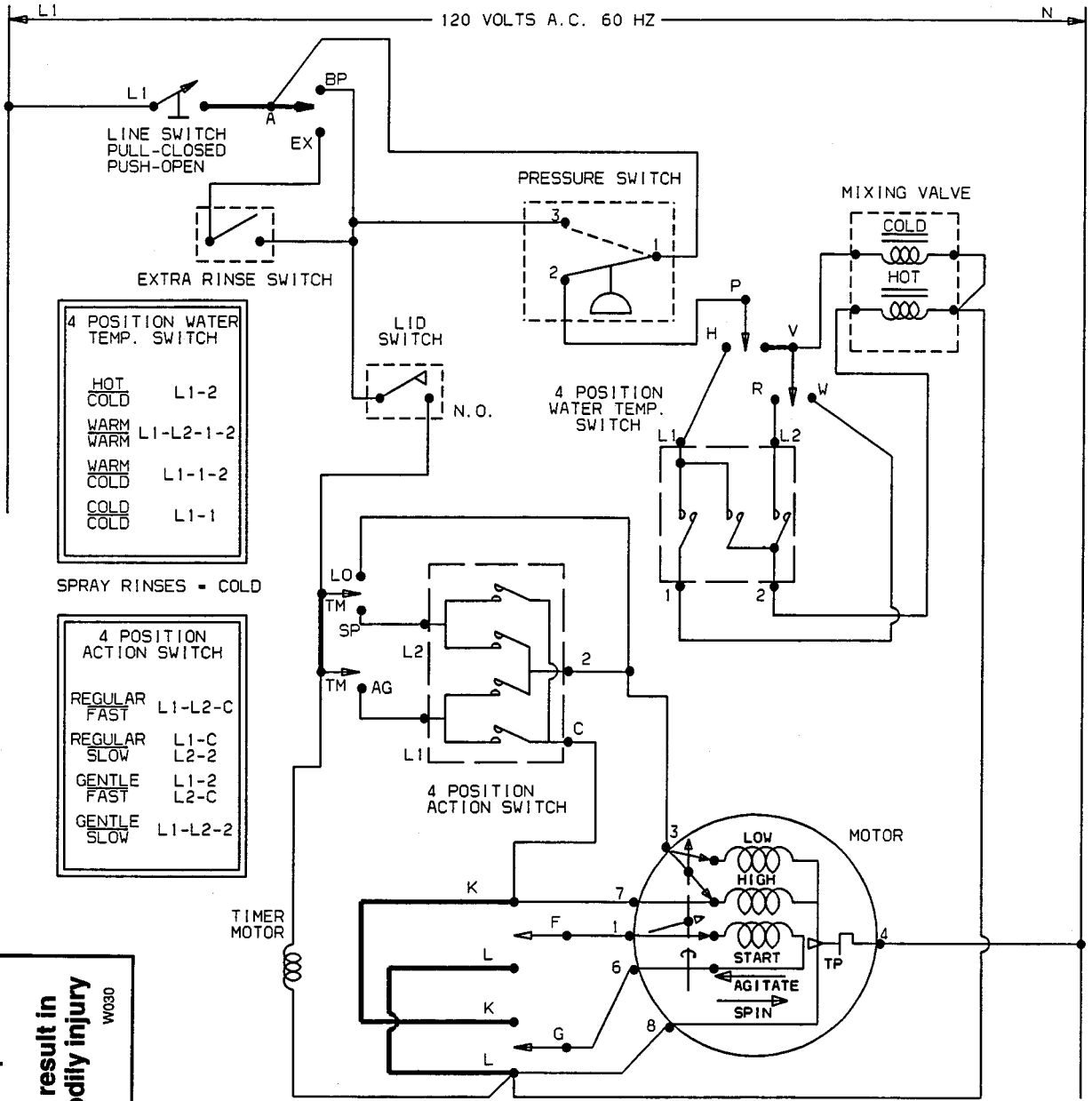

WARNING

Failure to install, maintain, and/or operate this machine according to the manufacturer's instructions may result in conditions which can produce bodily injury and/or property damage.

W030

MODEL LWA60A*

WARNING
 Failure to install, maintain, and/or operate
 this machine according to the
 manufacturer's instructions may result in
 conditions which can produce bodily injury
 and/or property damage.
 W030

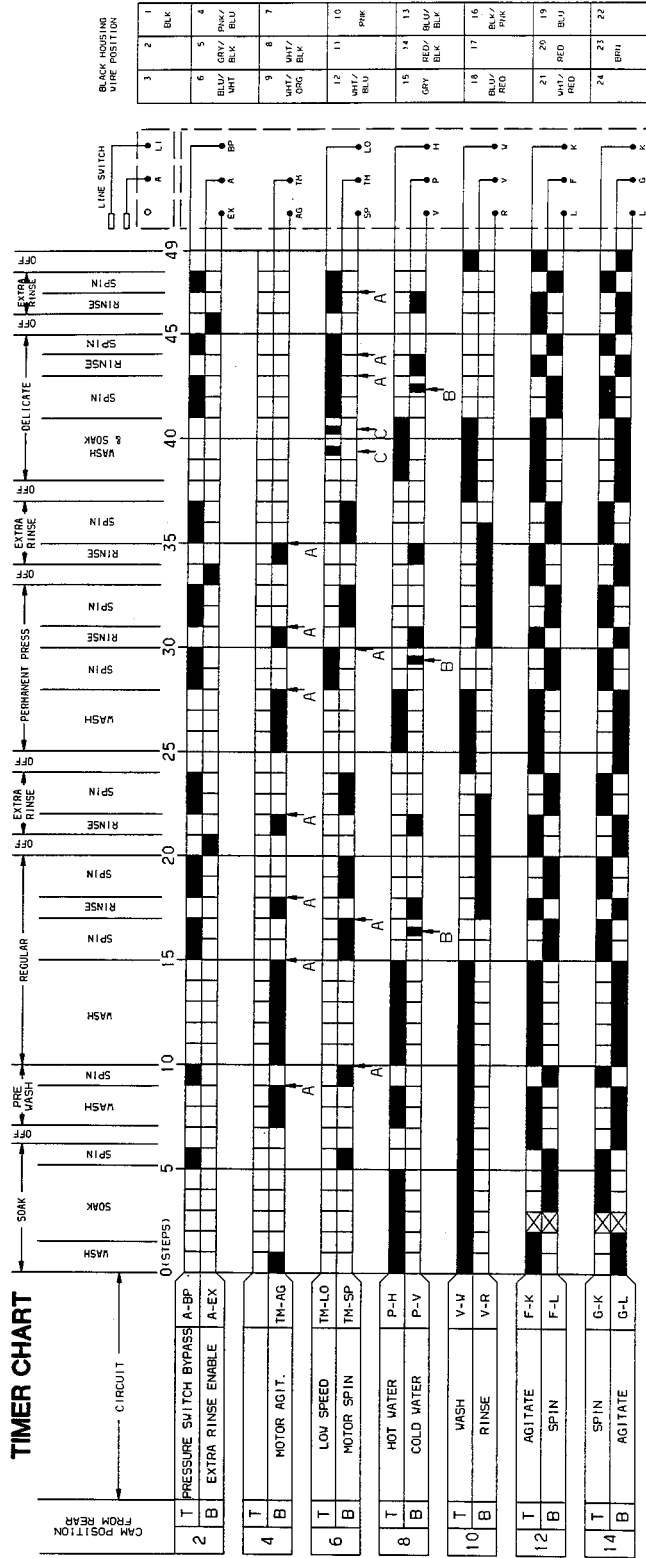

MODEL LWA60A*

WARNING

Failure to install, maintain, and/or operate this machine according to the manufacturer's instructions may result in conditions which can produce bodily injury and/or property damage.

W030

CONNECTION DIAGRAM

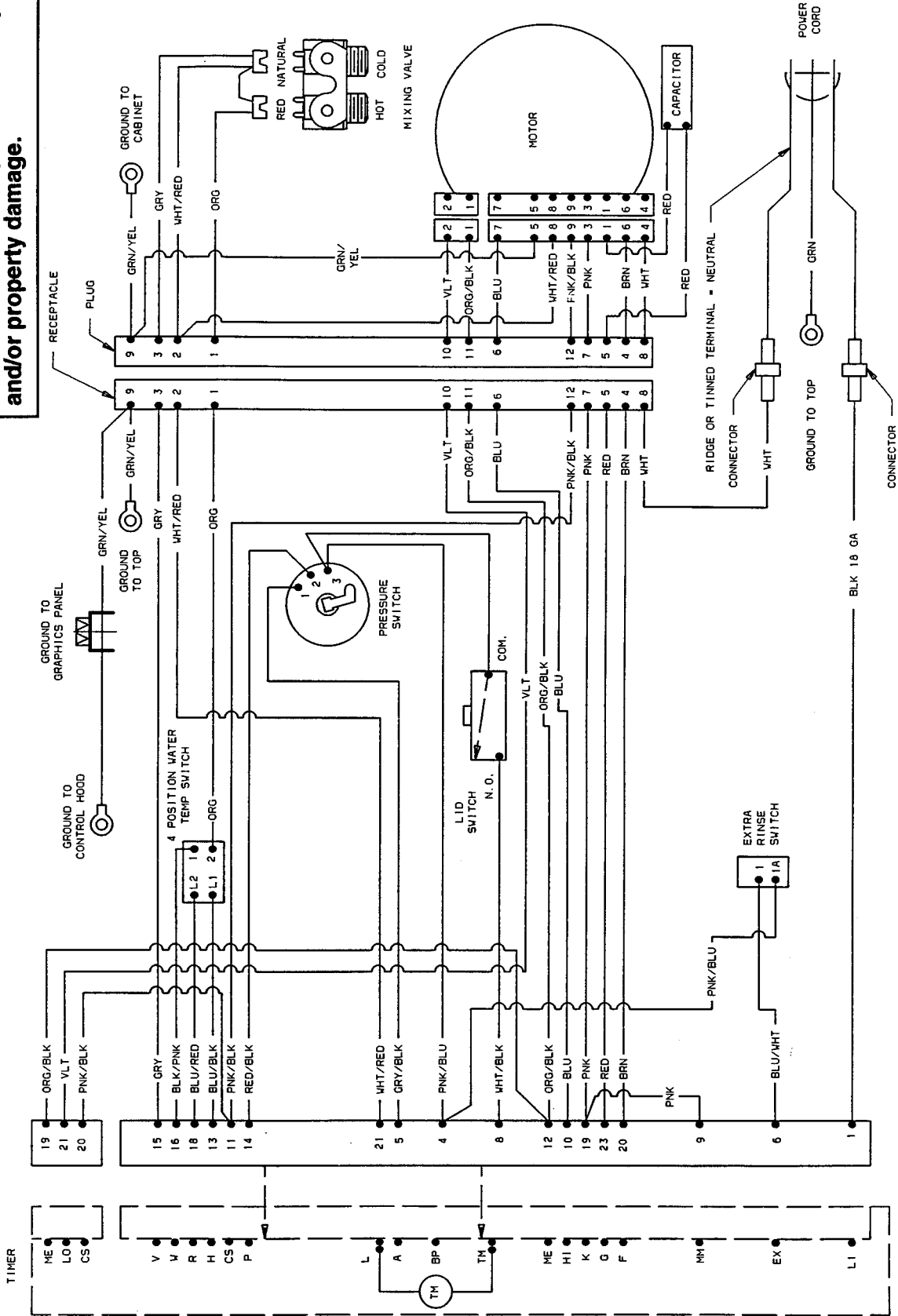

MODELS LWC75A* AND LWD75A*

SCHEMATIC

4 POSITION WATER TEMP. SWITCH	
HOT COLD	L1-2
WARM WARM	L1-L2-1 -2
WARM COLD	L1-1-2
COLD COLD	L1-1

SPRAY RINSES - COLD

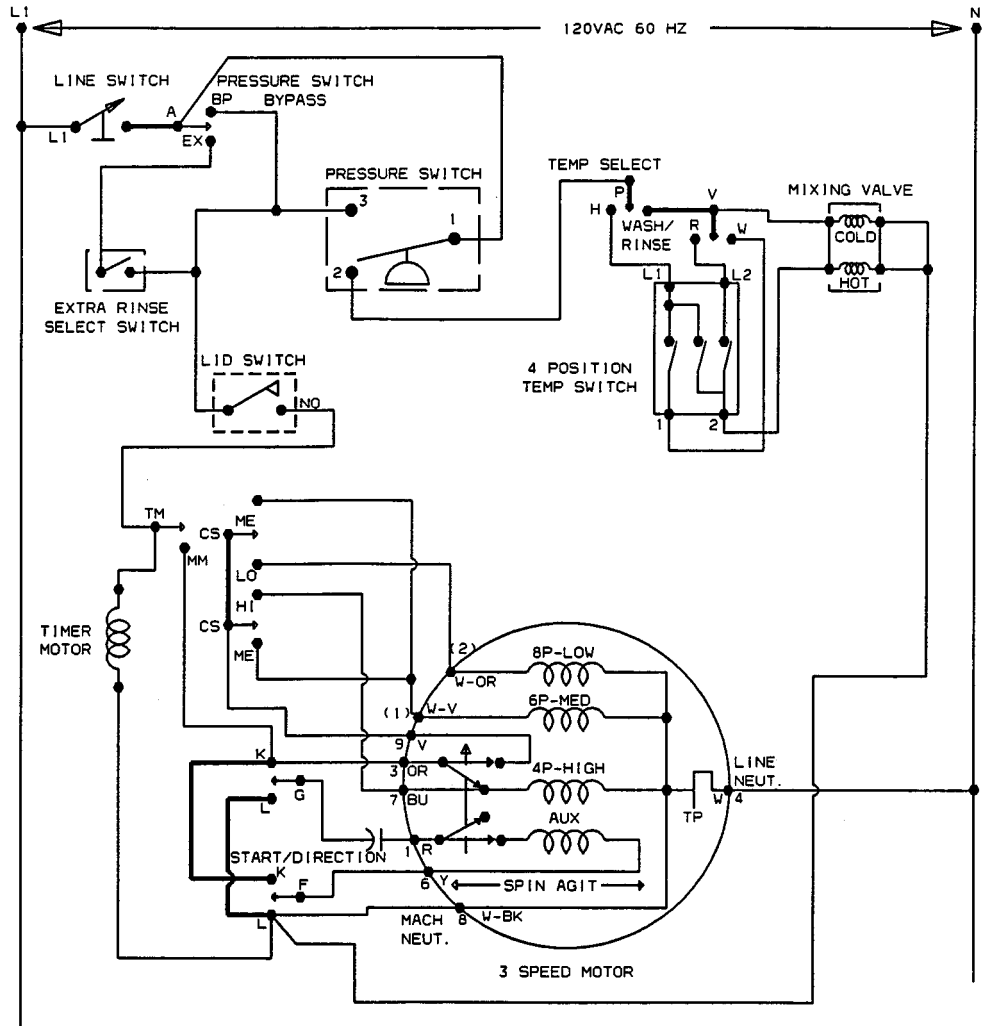

— INDICATES INTERNAL
TIMER BUSS

WARNING

Failure to install, maintain, and/or operate this machine according to the manufacturer's instructions may result in conditions which can produce bodily injury and/or property damage.

W030

MODELS LWC75A* AND LWD75A*

WARNING
 Failure to install, maintain, and/or operate this machine according to the manufacturer's instructions may result in conditions which can produce bodily injury and/or property damage.
 W030

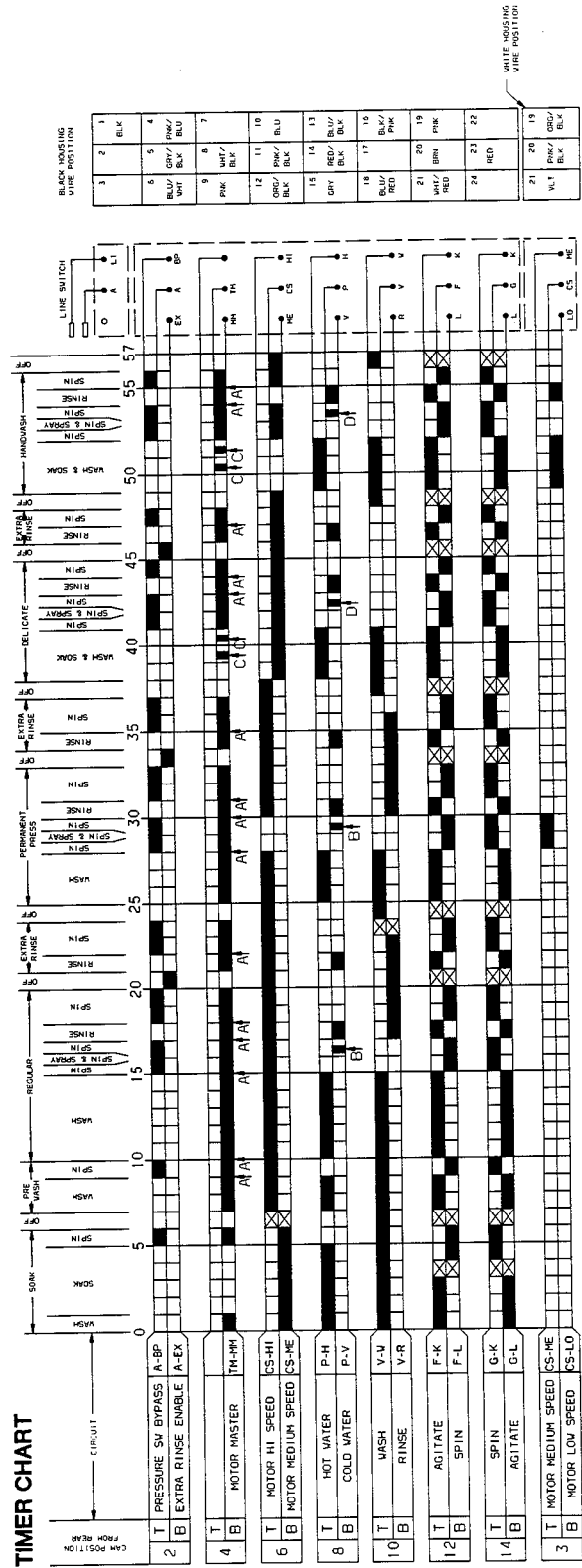

MODELS LWC75A* AND LWD75A*

WARNING

Failure to install, maintain, and/or operate this machine according to the manufacturer's instructions may result in conditions which can produce bodily injury and/or property damage.

W030

CONNECTION DIAGRAM

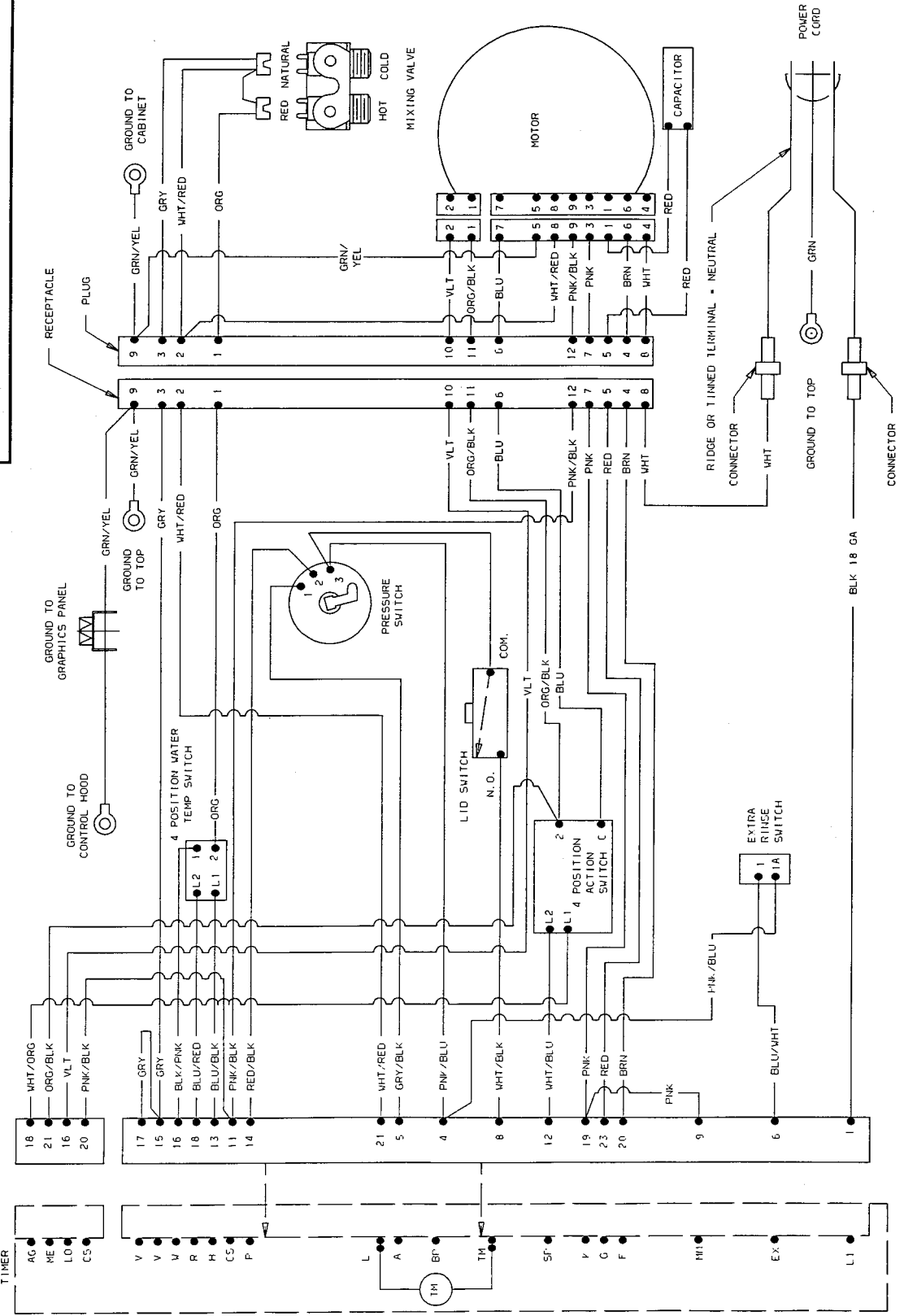

MODELS LWA80A* AND LWC80A*



WARNING

Failure to install, maintain, and/or operate this machine according to the manufacturer's instructions may result in conditions which can produce bodily injury and/or property damage.

W030

SCHEMATIC

4 POSITION WATER TEMP. SWITCH	
HOT	L1-2
COLD	L1-L2-1
WARM	WARM-2
WARM	L1-1-2
COLD	L1-1
COLD	

SPRAY RINSES = COLD

4 POSITION ACTION SWITCH	
REGULAR	L1-L2-C
FAST	L1-C
REGULAR	L2-2
SLOW	L1-2
GENTLE	L2-C
FAST	
GENTLE	L1-L2-2
SLOW	

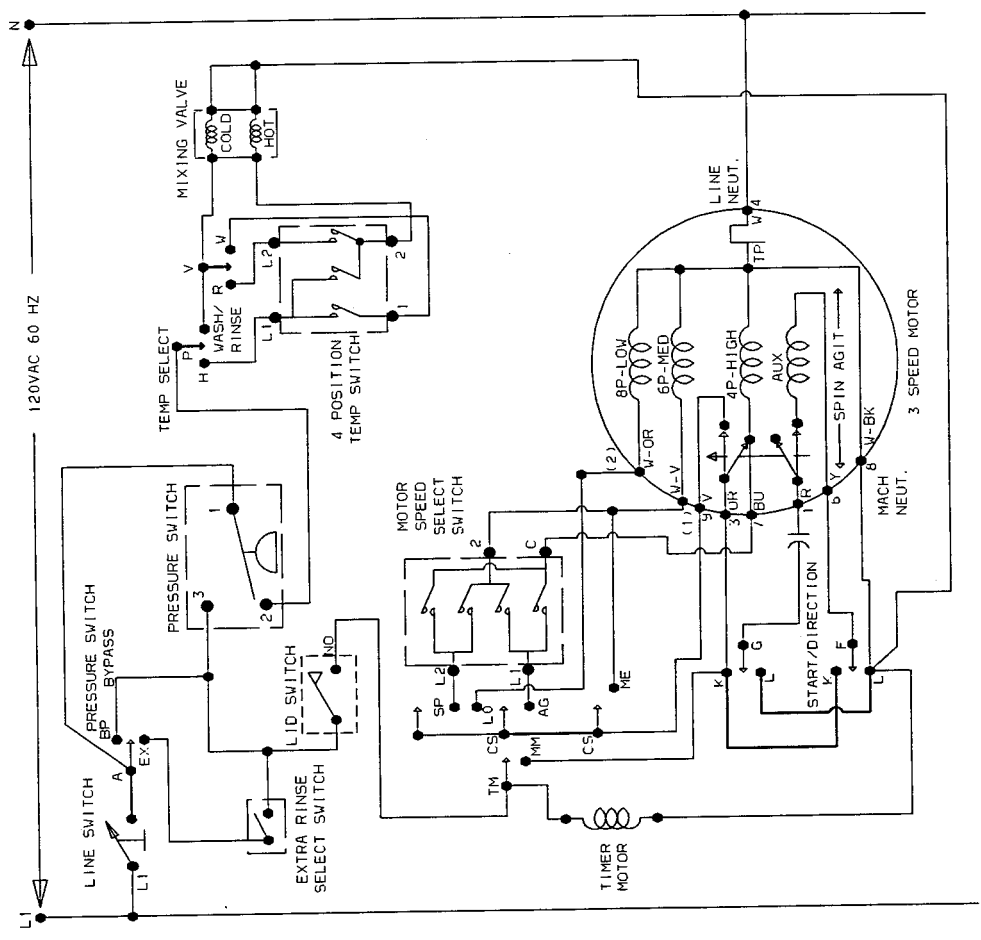

— INDICATES INTERNAL TIMER BUSS

MODELS LWA80A* AND LWC80A*

WARNING
 Failure to install, maintain, and/or operate this machine according to the manufacturer's instructions may result in conditions which can produce bodily injury and/or property damage.
 W030

TIMER CHART

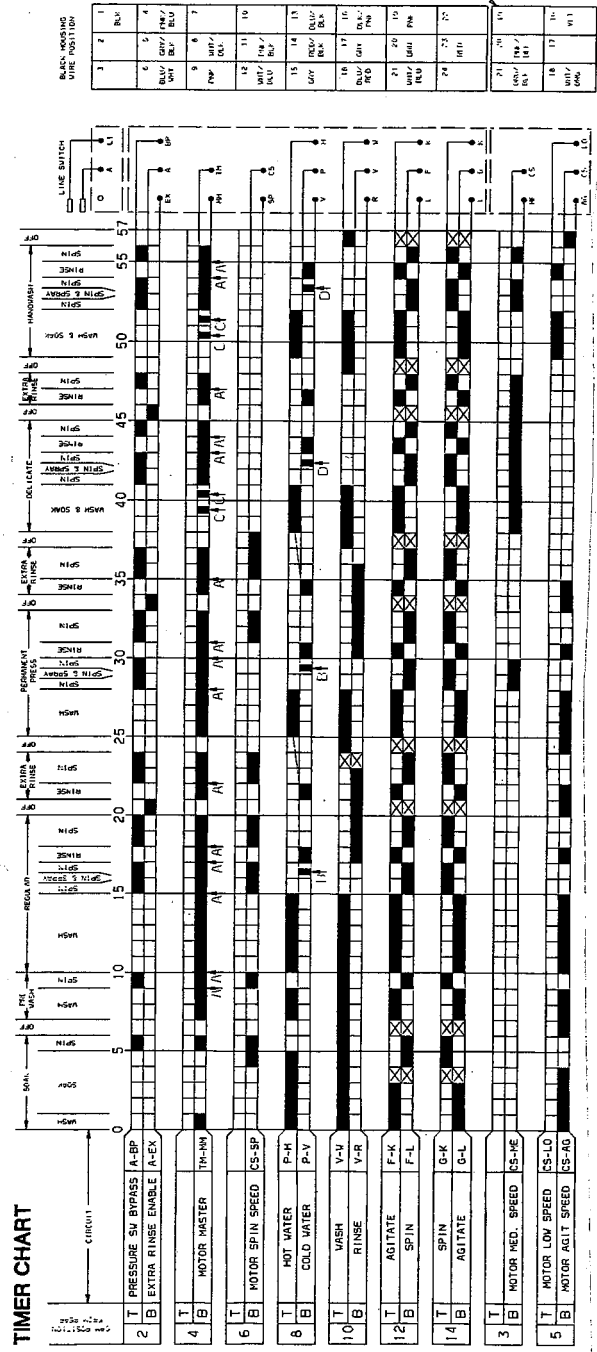

MODELS LWA80A* AND LWC80A*



WARNING

Failure to install, maintain, and/or operate this machine according to the manufacturer's instructions may result in conditions which can produce bodily injury and/or property damage.

W030

CONNECTION DIAGRAM

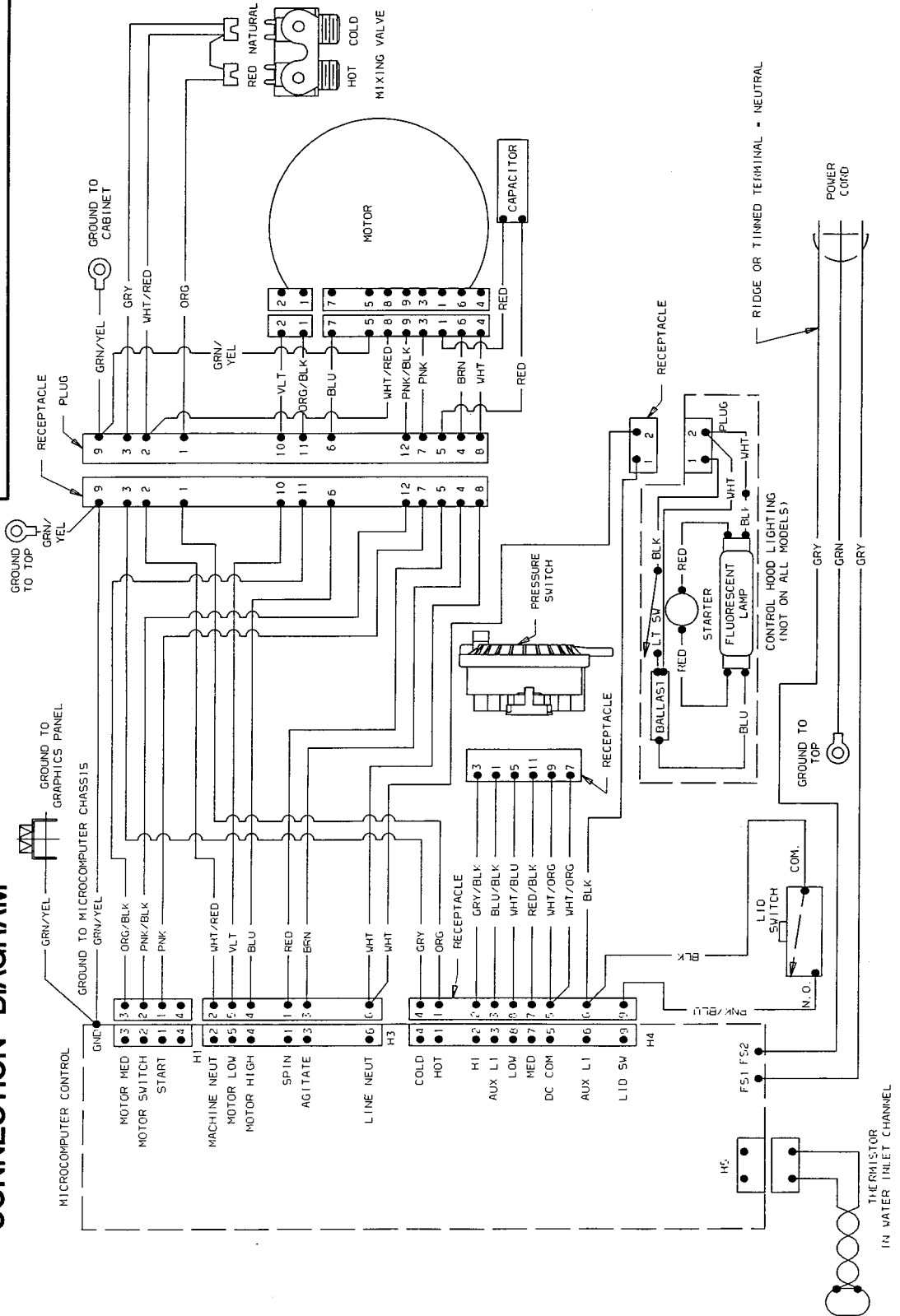

MODELS LWA90A* AND LWC90A*

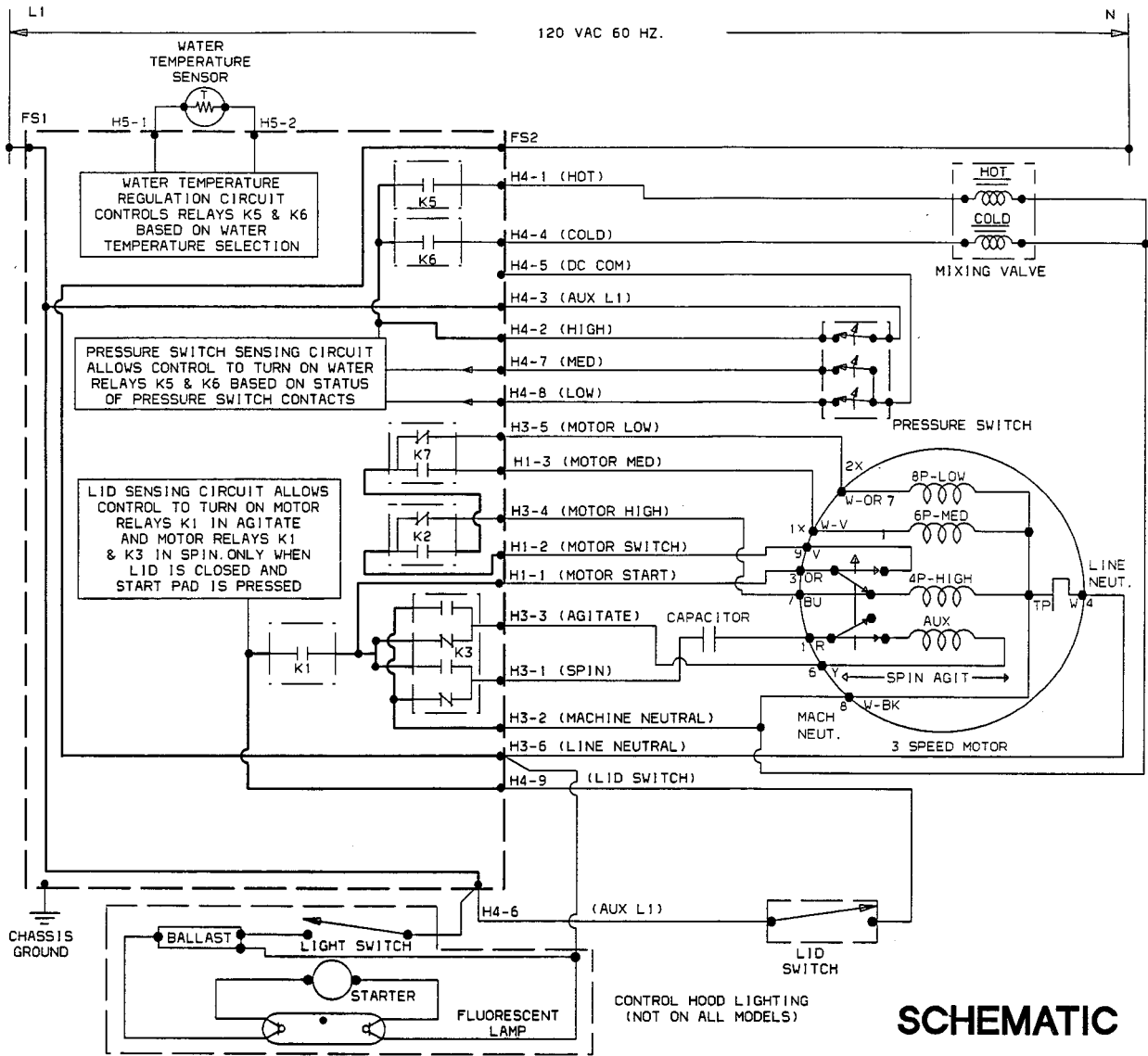

SCHEMATIC

— INDICATES INTERNAL BUSSING

WARNING

Failure to install, maintain, and/or operate this machine according to the manufacturer's instructions may result in conditions which can produce bodily injury and/or property damage.

W030

MODELS LWA90A* AND LWC90A*

