

IMPORTANT

Remove the plug from the mains power supply when carrying out any operations on the machine.

INTRODUCTION

This manual has been written taking into consideration most of the electronic washing machines and washer/driers in our production range and possessing various construction technologies and aesthetics (with or without LCD display). Consequently, this Manual must be used together with all the other technical documents appertaining to the product in question (exploded views, wiring diagrams, technical information sheets, etc.).

WATER SUPPLY

This manual provides instructions for connecting the appliance to the mains water supply, with explanations for washing machines with cold water feed only and those with both a hot and cold water feeds.

The water pressure must be between 0.05 and 1 Mpa.

RATING PLATE

The rating plate is located on the inside of the filter door on the front of the washing machine. If the filter door needs to be replaced, remove the rating plate from the door itself and attach it to the new one.

The rating plate reports all the nominal data required by current standards (power supply voltage, total absorbed power, etc...).

The serial number consists of 11 characters that indicate the date of manufacture and serial number:
For example:

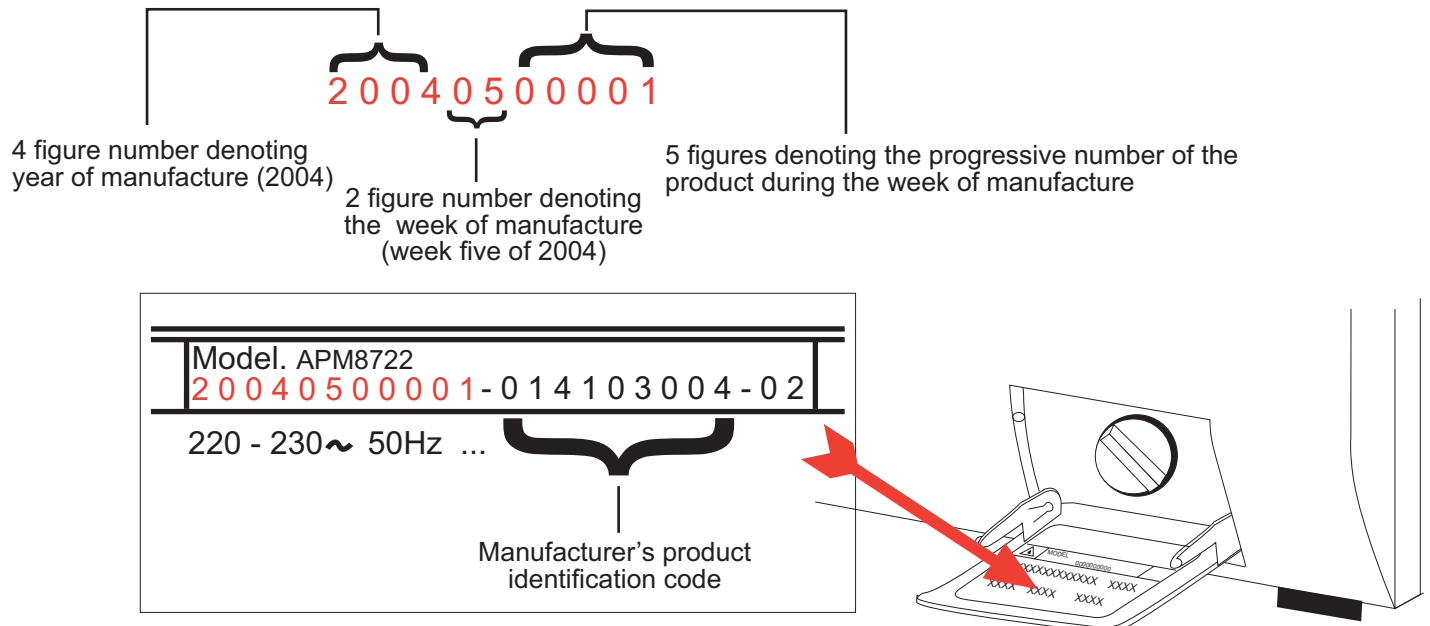

Should any problems occur with the washer drier, the Main Technical Assistance Office in your country must be informed of the serial number and the model in question in order to help the manufacturer identify the product.

SAMPLE OF WIRING DIAGRAM

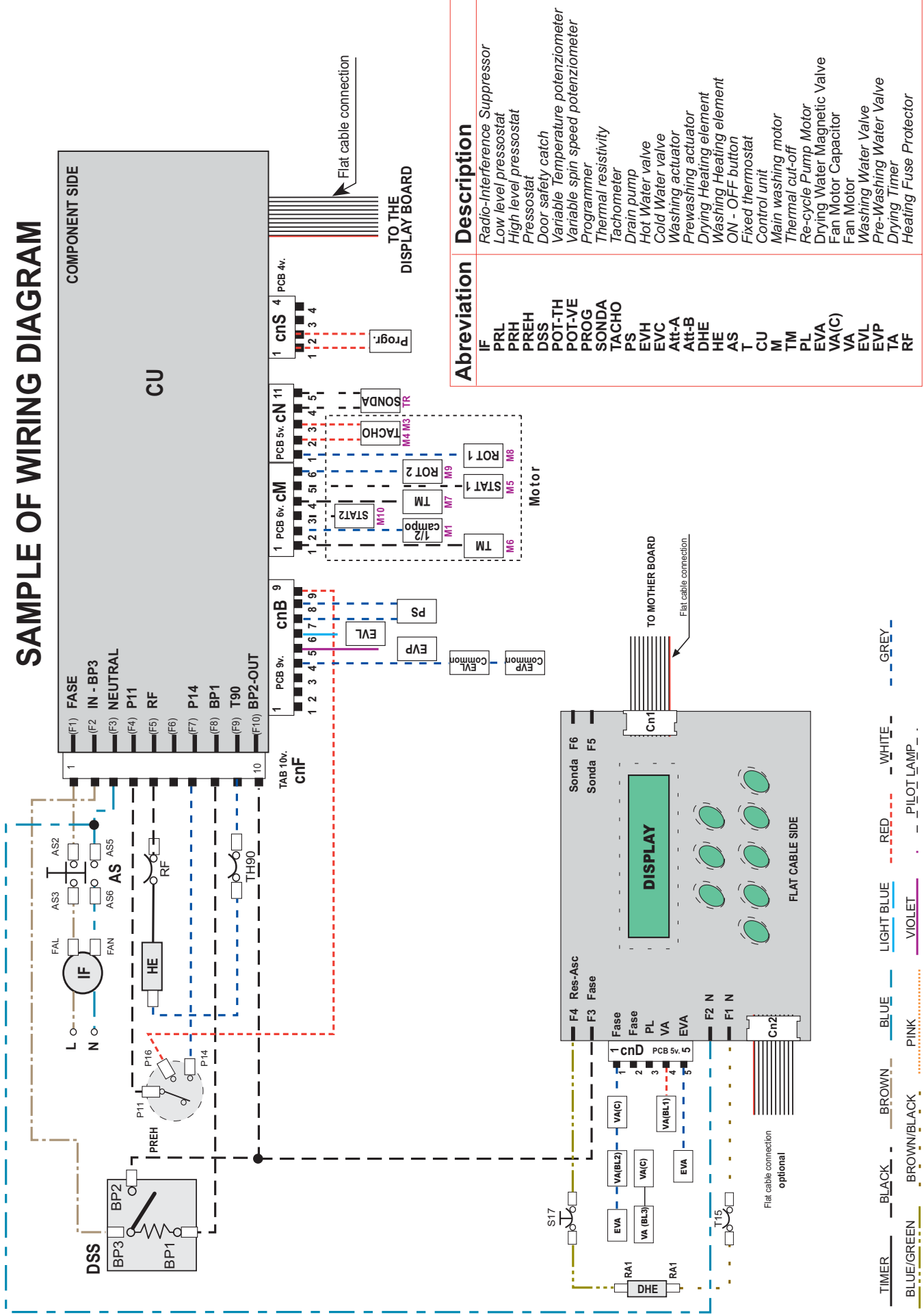

1.	General specifications		Voltage (according to the model) Max. absorption Fuse	230V /240V± 10% / 50 Hz 2200 W 10 A
----	-------------------------------	---	---	---

2.	Drum speed	Slow spin \longrightarrow 550 rpm High speed spin \longrightarrow according to the model
----	-------------------	---

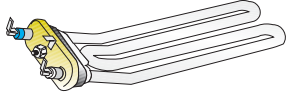
3.	Tubular wash heater element with internal fuse		Power rating (Appliances with 42 litre drum) Power rating (Appliances with 65 litre drum) Voltage (according to the model)	1950 W / 2100 W 1950 W / 2100 W 230 V / 240 V
----	---	---	--	---

Warning: the Blue terminal indicates the internal thermofuse (RF)

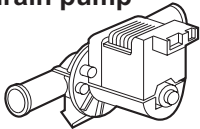
4.	Synchronous drain pump		Power rating Insulation class Voltage Flow rate Height of drain hose	approx. 30 W "F" 230-240V AC 50Hz 15 - 16 l/min. max. 0,90 m min. 0,60 m
----	-------------------------------	---	--	---

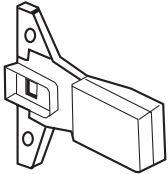
5.	Safety door catch		When a wash or dry (in the case of a washer/drier) program is in progress, a safety device prevents the door from being opened. To open the door while a wash program is running, switch off the washing machine using the On/Off button. The door can then be opened after a time lapse of approximately 2 minutes.
----	--------------------------	---	--

NEVER OPEN THE DOOR IF THE WATER LEVEL IS VISIBLE THROUGH THE DOOR GLASS.

At the end of the cycle, wait for the END indicator to light up before opening the door.

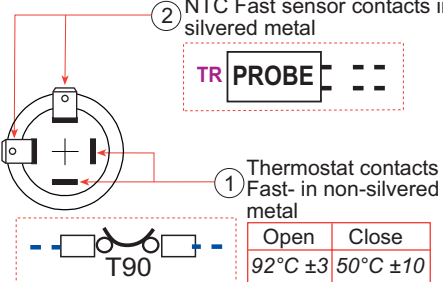

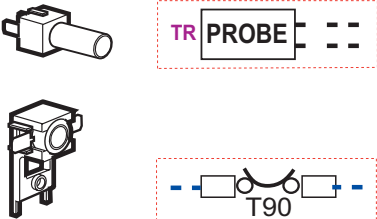
6.A	Version with fixed safety thermostat with incorporated thermistor (water in tub temperature sensor)		Fixed safety thermostat 92°C ±3 with automatic reset and Normally Closed Contact. The NTC sensor allows precise control of the temperature (+/- 2°C). As the temperature of the water increases, the ohmic resistance of the sensor decreases. To check the operation of the component, heat the water to 25°C, then use a tester to check that the ohmic resistance is around 5 kOhm.
-----	--	---	--

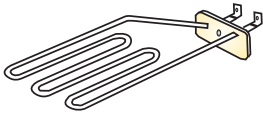
6.B	Version with fixed safety thermostat and separate thermistor (water in tub temperature sensor)		The NTC sensor allows precise control of the temperature (+/- 2°C). As the temperature of the water increases, the ohmic resistance of the sensor decreases. To check the operation of the component, heat the water to 25°C, then use a tester to check that the ohmic resistance is around 5 kOhm.
-----	---	---	---

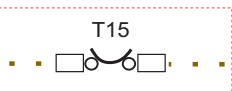
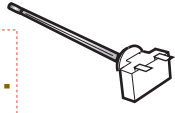
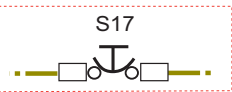

7.A	Tubular type drying heater element (for washer/driers with 42 litre drum only)		Power rating Voltage (according to the model)	1150 W / 1150 W 230 V / 240 V
-----	---	---	--	----------------------------------

7.B	Tubular type drying heater element (for washer/driers with 65 litre drum only)		Power rating Voltage (according to the model)	1500 W / 1500 W 230 V / 240 V
-----	---	---	--	----------------------------------

8.A Fixed drying thermostats (for washer/driers with 42 litre drum only)

 <p>T15</p>	 <p>108°C</p>	<p>108°C long bulb fixed thermostat with automatic reset Normally Closed Contact. Controls the drying temperature.</p>
 <p>S17</p>	 <p>170°C</p>	<p>Manual reset fixed safety thermostat Normally Closed Contact. Intervenes only if there is a fault in the 108° auto reset long bulb drying thermostat or in the fan and drying unit.</p>

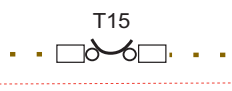
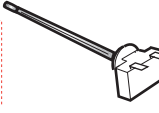
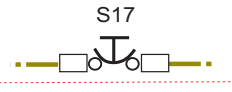
8.B Fixed drying thermostats (for washer/driers with 65 litre drum only)

 <p>T15</p>	 <p>142°C</p>	<p>142°C long bulb fixed thermostat with automatic reset Normally Closed Contact. Controls the drying temperature.</p>
 <p>S17</p>	 <p>170°C</p>	<p>1/2" 170°C fixed safety thermostat with manual reset. Normally Closed Contact. Intervenes only if there is a fault in the 142° auto reset long bulb drying thermostat or in the fan and drying unit.</p>

9.A Drying fan motor (for washer/driers with 42 litre drum only)

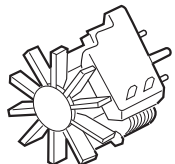
 <p>VA</p>		<p>Power rating Voltage (according to the model) Rotation Ohmic resistance at temperature 22.5°C</p>	<p>approx. 69 W 230/240V approx. 2800 rpm 36,7 ohm ± 7%</p>
--	---	--	---

9.B Drying fan motor (for washer/driers with 65 litre drum only)

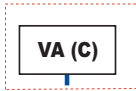
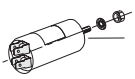
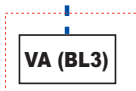
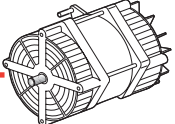
 <p>VA (C)</p>	 <p>H019</p>	<p>Capacitor</p>	<p>4 Microfarad</p>
 <p>VA (BL3)</p>	 <p>H290</p>	<p>2-pole with Anticlockwise rotation - Class F Power rating Voltage (according to the model)</p>	<p>approx. 2750 rpm approx. 150 W 230/240V</p>

10. Main power supply switch:

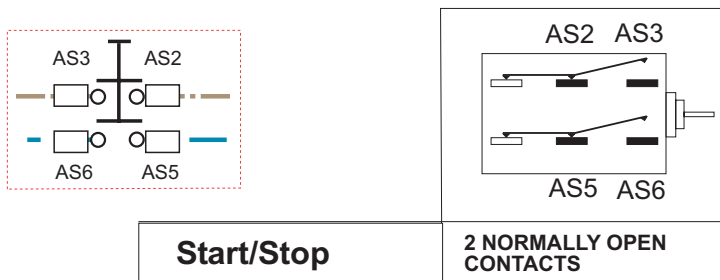

Description of the functions of the switch:

Start/Stop switch

Switches the power supply to the washing machine on or off.

11. Pressure Switch

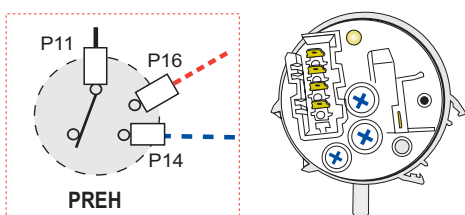

A single level pressure switch is used with the following functions:

P11-P14

- Signals the electronic control unit (open/closed) that the low water level has been reached.
- heater element safety switch.

Contact P16 functions as an overflow safety device and trips when there is too much water in the tub.

Washing machine fill levels.

The washing machine levels are calculated by the electronic control unit according to the type and quantity of washing placed in the tub and the set program, and adds a safety margin which is pre-programmed in the module software.

12. Version with 2-way cold water solenoid valve.

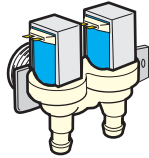
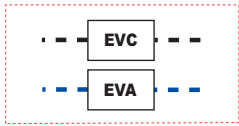

1) Wash

Flow rate (for each valve):
Working pressure:

MAX. 12 l / min
MIN. 0,05 - 1 MPa

Voltage (according to the model)

230/240V 50-60Hz

13. Version with 1-way hot water solenoid valve.

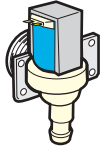
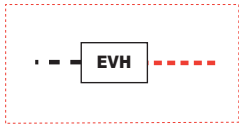

1) Wash

Flow rate:
Working pressure:

MAX. 10 l / min
MIN. 0,05 - 1 MPa

Voltage (according to the model)

230/240V 50-60Hz

14. Version with 3-way cold water solenoid valve (for washer/driers with 65 litre drums only).

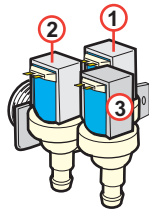
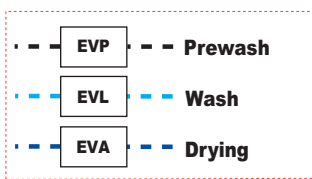

3) Prewash

Black coil Flow rate:
Working pressure:

MAX. 10 ±15% l / min
MIN. 0,05 - 1 MPa

2) Wash

Black coil Flow rate:
Working pressure:

MAX. 10 ±15% l / min
MIN. 0,05 - 1 MPa

1) Drying

Black coil Flow rate:
Working pressure:

MAX. 0,35 ±25% l / min
MIN. 0,05 - 1 MPa

Voltage (according to the model)

230/240V 50-60Hz

15. Version with cold plug type thermo-actuators with 220-240 V – 50 Hz power supply for feeding water to the detergent dispenser:

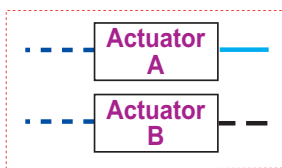

THERMO-
ACTUATOR
B

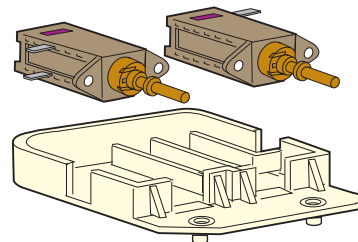

THERMO-
ACTUATOR
A

Description of water distribution during a wash cycle

- PREWASH PHASE:** Both thermo-actuators are inactive.
During the **drain** phase, thermo-actuator **A** is active.
- WASH PHASE:** Thermo-actuator **A** is active.
- CONDITIONER PHASE:** Thermo-actuator **B** is active.

16. Potentiometer for Spin Speed, Delayed Start or Drier Timer selection function.

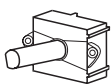

The electronic appliances can be fitted with different types of positive logarithmic potentiometer according to the functions they have to fulfil:

- 8 fixed positions with Maximum Ohmic Resistance 50 kOhms.
- 12 fixed positions with Maximum Ohmic Resistance 36 kOhms.

The maximum Ohmic resistance value is obtained with the flat on the shaft pointing upwards. Consequently, when the index of the knob is pointing down.

Wiring diagram symbols

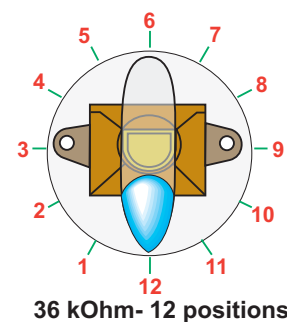
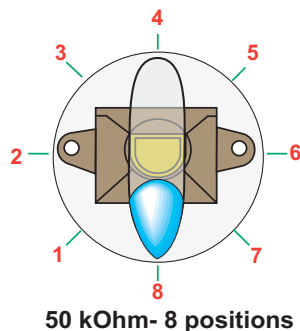
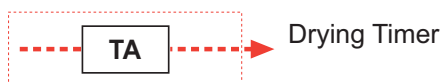

17. Wash program selection potentiometer.

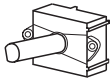

The electronic washing machines can be fitted with one of two types of positive logarithmic potentiometer:
 - 50 kOhm with 16 fixed positions
 - 63 kOhm with 20 fixed positions
 Their use depends purely on the number of programs for which the appliance has been designed.
 The maximum Ohmic resistance is the reference value used to start the Autotest procedure.



Wiring diagram symbols

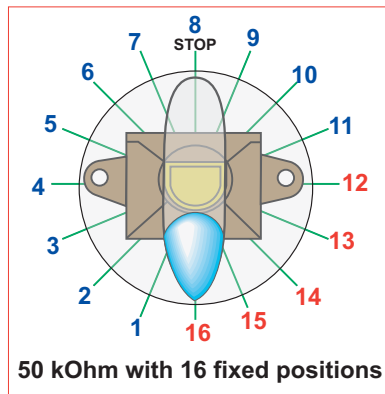

Important:
 The positions in red are those used for the various phases of the autotest.

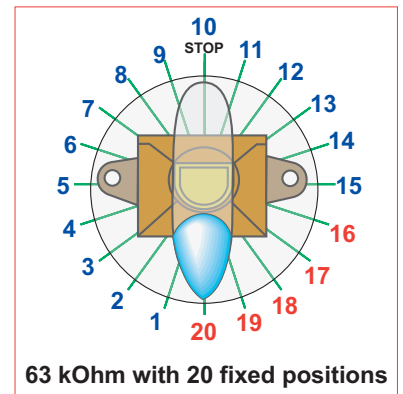

Program selector.

The start of a particular program is commanded by a wash code sent by the program selector (potentiometer) to the control unit.
 The process also depends on the pressure switch signal: An **OPEN P11 - P14** contact enables the water feed or spin, while a **CLOSED P11 - P14** contact enables the motor to run during the wash and the heating phase.
 The thermistor, tachometric and optional button signals are important for enabling the control unit microprocessor to run the required program. Note that each wash code of the program selector corresponds to a number of operations managed by the microprocessor.

18. Commutator motor 220-240V 50-60 Hz.

The commutator motor can be powered by: direct current (DC), recognisable by the 1/2 FIELD contact on the terminal board, or by alternating current (AC).

Appliances with 42 litre drum volume:
 - AC motor, spin speed 800 rpm -1100 rpm
 - DC motor, spin speed 1200 rpm -1600 rpm

Appliances with 55 litre drum volume:
 - AC motor, spin speed 800 rpm -1000 rpm
 - DC motor, spin speed 1100 rpm -1600 rpm

Appliances with 65 litre drum volume:
 - DC motor, spin speed 800 rpm -1600 rpm

AC commutator motor terminal board

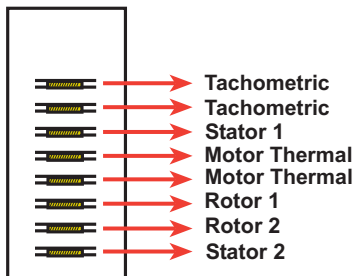

DC commutator motor terminal board

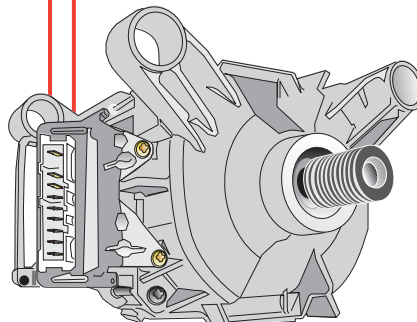
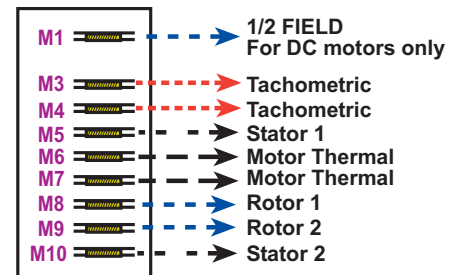

IMPORTANT:

- It is not possible to replace just the tachometric on commutator motors.
- The motor brushes are not supplied as single spare parts.
- It is not technically possible to measure the ohmic resistance of this type of motor using a tester.
- The nominal data is reported on the motor itself.

TECHNICAL DATA

Water fill principle

At the start of the wash program, the control unit, according to the program selected, commands the solenoid valve to feed water to the appliance providing the pressure switch authorises the action (the pressure switch must be OFF). When the required water level has been reached, the control unit closes the solenoid valve.

If the pressure switch detects excess water entering the appliance, it sends a signal to the control unit which then starts the drain pump.

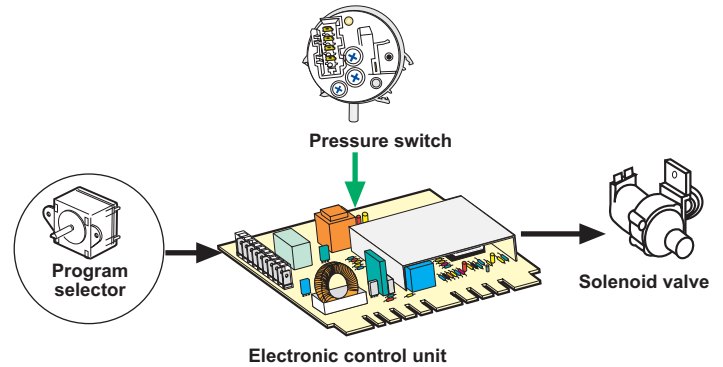

Heating phase principle

The heater element switches on when pressure switch contact P11-P14 is closed (water in the tub). A traditional thermostat to interrupt the power supply to the heater element is not provided.

The control unit receives the Ohmic value of the resistance and switches off the heater element when the correct temperature has been reached.

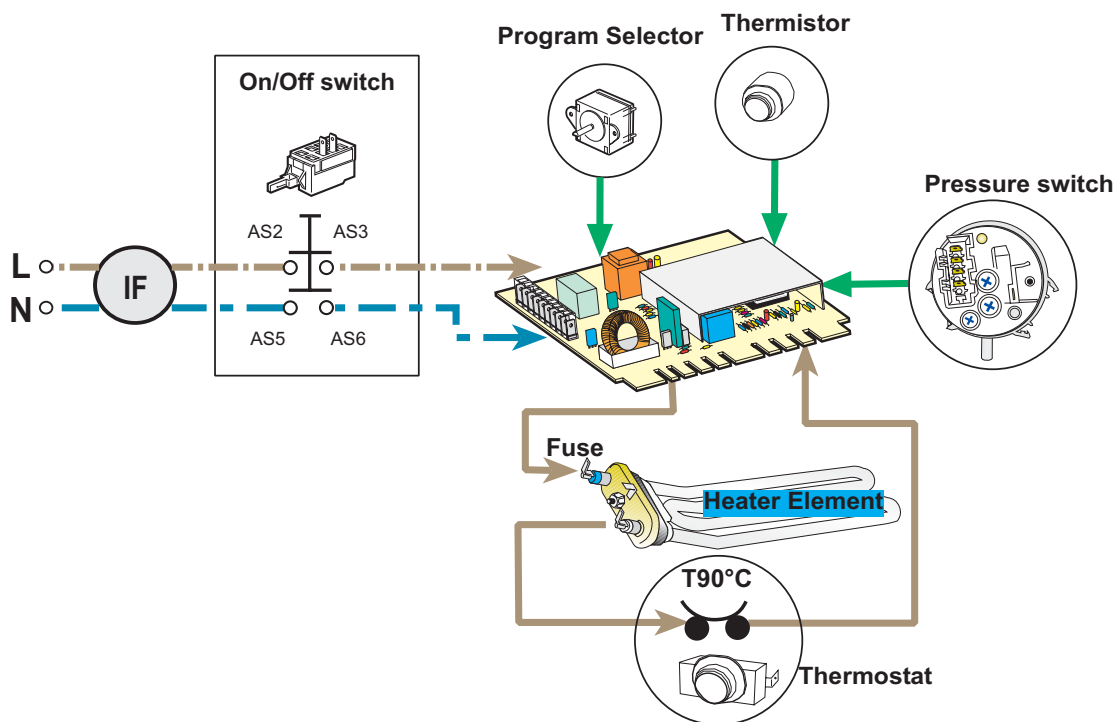

Cooling

The cooling phase is necessary in order to ensure that the water pumped to the domestic drainage system is not too hot.

This is always carried out for the COTTON program if the temperature is higher than 70°C. The water is gradually cooled down by allowing cold water to enter after the last wash cycle and before draining. The control unit feeds the cold water for one minute, pauses one minute then drains.

During DELICATE and SYNTHETIC programs, the cooling is always carried out before draining by activating the solenoid valve for 10 seconds.

Wash load balance control

The washing machines are fitted with an electronic balance control which is active in all the spinning phases.

At the start of the spin cycle, the load balance is checked by the control unit. If the load in the drum is unbalanced, the washing machine attempts to start the spin a number of times. If the control unit detects that the load is very unbalanced, the entire spin cycle may last as long as 20 minutes (even if the display still shows 12' (minutes)).

Electronic washer/drier version
water feed through 2 plug type
thermo-actuators

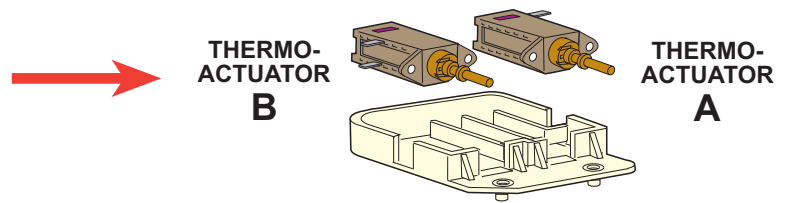

FUNCTIONS OF THE CONTACTS

- cnF1 receives power from the **ON-OFF** button
- cnF2 feeds door catch contact **BP3**
- cnF3 current output to **ON-OFF** button
- cnF4 feeds pressure switch contact **P11**
- cnF5 feeds the **heater element** through the internal safety **thermo-fuse**
- cnF6 -----
- cnF7 receives the pressure switch level reached signal from contact **P14**
- cnF8 feeds door catch contact **BP1**
- cnF9 receives the return signal from the heater element through **safety thermostat T90°C** which, when the temperature is reached, opens the contact
- cnF10 feeds door catch contact **BP2**

- cnB1 common to Solenoid valve **EVC** (and **EVH** where fitted)
- cnB2 feeds Cold Water Solenoid Valve **EVC**
- cnB3 feeds Hot Water Solenoid Valve **EVH** (where fitted)
- cnB4 common **Thermo-actuator A** and **Thermo-actuator B**
- cnB5 power supply **Thermo-actuator A (Wash)**
- cnB6 power supply **Thermo-actuator B (Softener)**
- cnB7-8 power supply **Drain pump**
- cnB9 return signal from **pressure switch overflow safety**, starts the pump.

- cM1 Motor (**Thermal**)
- cM2 Motor (**1/2 field**)
- cM3 Motor (**Stator 2**)
- cM4 Motor (**Thermal**)
- cM5 Motor (**Stator 1**)
- cM6 Motor (**Rotor 2**)

- cn1 Motor (**Rotor 1**)
- cn2 Motor (**Tachometric**)
- cn3 Motor (**Tachometric**)
- cn4-5 **Thermistor** (temperature control sensor)

cnS1-2 Program selector **potentiometer**

Flat cable receives information from the pushbutton circuit board (wash options) and sends information to the display (program status).

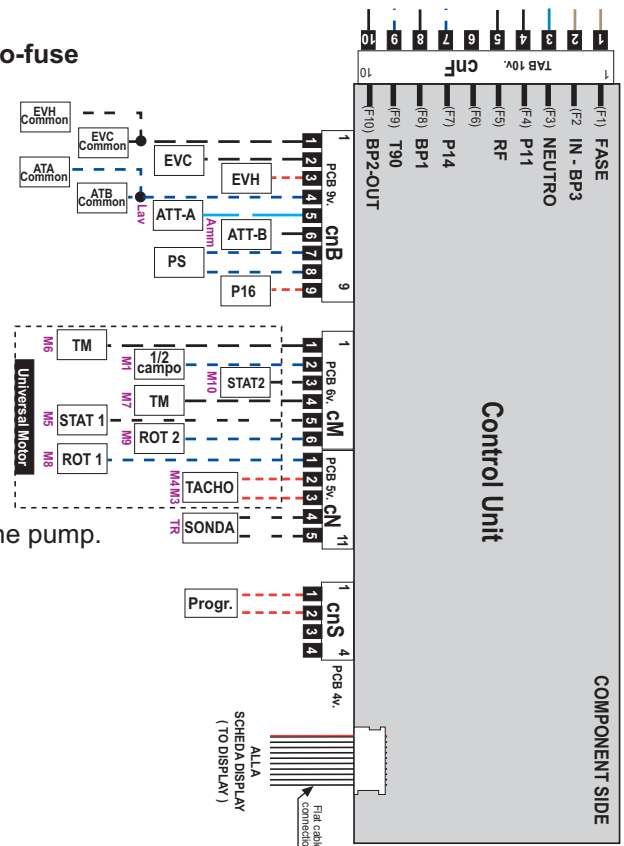

Electronic Washer/drier version with water feed through a 3-way solenoid valve

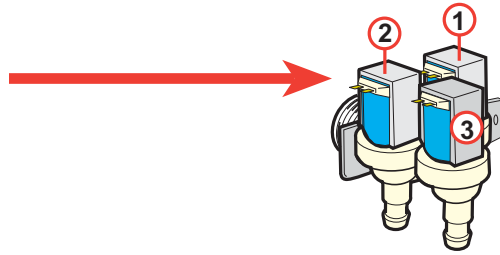

FUNCTIONS OF THE CONTACTS

- cnF1 receives power from the **ON-OFF** button
- cnF2 feeds door catch contact **BP3**
- cnF3 current output to **ON-OFF** button
- cnF4 feeds pressure switch contact **P11**
- cnF5 feeds the **heater element** through the internal safety **thermo-fuse**
- cnF6 -----
- cnF7 receives the pressure switch level reached signal from contact **P14**
- cnF8 feeds door catch contact **BP1**
- cnF9 receives the return signal from the heater element through **safety thermostat T90°C** which, when the temperature is reached, opens the contact
- cnF10 feeds door catch contact **BP2**

- cnB1 -----
- cnB2 -----
- cnB3 -----
- cnB4 common to Solenoid valve **EVP** (Prewash) and **EVL** (Wash)
- cnB5 feeds Prewash Solenoid Valve **EVP** (Prewash)
- cnB6 feeds Prewash Solenoid Valve **EVL** (Wash)
- cnB7-8 power supply **Drain pump**
- cnB9 return signal from **pressure switch overflow safety**, starts the pump.

- cM1 Motor (**Thermal**)
- cM2 Motor (**1/2 field**)
- cM3 Motor (**Stator 2**)
- cM4 Motor (**Thermal**)
- cM5 Motor (**Stator 1**)
- cM6 Motor (**Rotor 2**)

- cn1 Motor (**Rotor 1**)
- cn2 Motor (**Tachometric**)
- cn3 Motor (**Tachometric**)
- cn4-5 **Thermistor** (temperature control sensor)

cnS1-2 Program selector **potentiometer**

Flat cable receives information from the pushbutton circuit board (wash options) and sends information to the display (program status).

The use of different types of wiring means that the number of connectors may vary, though the control unit is always the same. Consequently, the wiring diagram shown above remains valid (providing the connectors have been wired correctly) in that it refers to the contacts on the control unit itself.

In the case of a fault, always check the control unit contacts (connectors). A false contact can compromise the correct execution of the program.

Explanation of the data reported on the electronic control unit label:

- A = Maximum spin speed
- B = Information for line testing
- C = Voltage/Frequency
- D = Control unit type
- E = Appliance type
- F = Control unit production date
- G = Control unit code
- H = Control unit/update version
- I = Control unit barcode

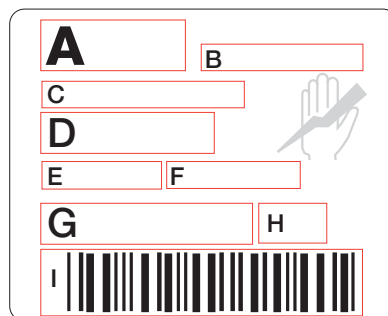

Esempio: →



IMPORTANT:

Before replacing an electronic control unit, use the autotest to make sure that all the electric components are working properly, that the contacts of the electronic control unit connections are sound and that the mains voltage is within the required limits.

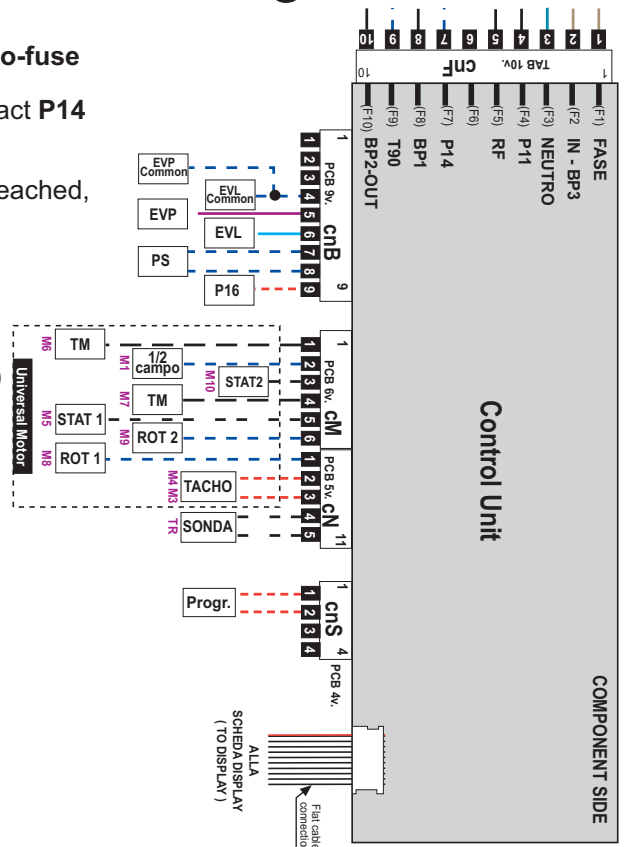

Positions of the buttons on the various model styles:

General:

There are two different types of electronic washing machine and/or washer/drier: **with small Display, with large LCD Display, without Display, with one or two knobs**. These types may be further subdivided according to their particular styling in terms of the positions of the wash option buttons. This, however, does not influence the operation of the appliance, in that the operation of the electronic control unit is the same in all cases, regardless of any extra functions that may be available on some models.

Example of an appliance with 2 knobs and without display

- 1 - On/Off button
- 2 - Start button
- 3 - Wash/Start Autotest options button
- 4 - Wash options button
- 5 - Spin speed selector knob
- 6 - Program selector knob

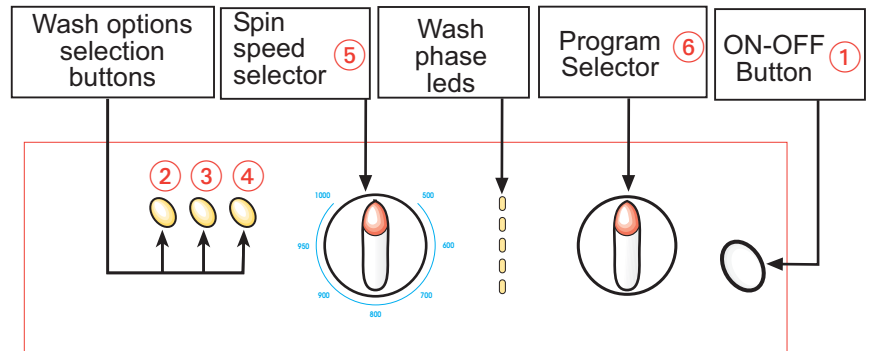

Example of an appliance with 1 knob and small display

- 1 – Wash options button
- 2 – Wash options button
- 3 – Wash options button
- 4 – Wash options button
- 5 – Wash options button
- 6 – Wash options button
- 7 – Wash options button
- 8 - ON/OFF button
- 9 - Program selector knob

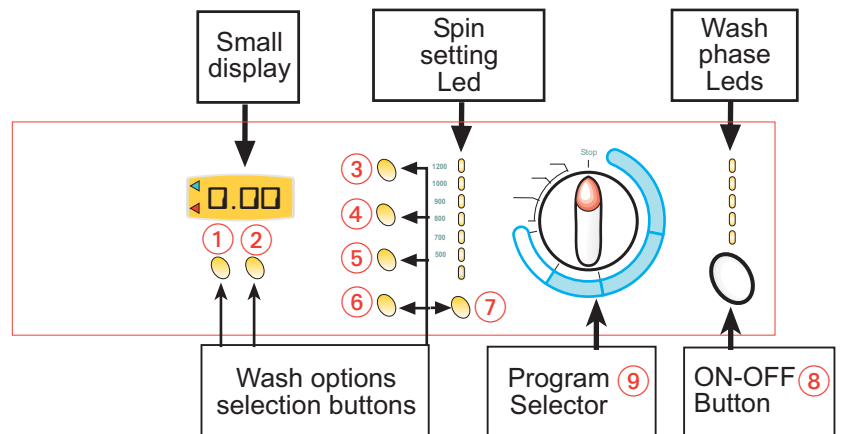

Important:

The wash option buttons are always numbered in ascending order from left to right and from top to bottom.

The layout of the option buttons may vary according to the model.

In order to identify the button used to start the autotest, remember that:

- on models without a display, the second wash option button is always used.

- on models with a display, the second wash option button (not counting the Start or Programmed Start buttons) is used.

For example:

Example 1

- 1 – Option button Start **not usable for the autotest**
- 2 – Option button Programmed Start **not usable for the autotest**
- 3 – Option button Prewash – first usable button
- 4 – Option button Spin delay – second usable button – **Used to start the Autotest**
- 5 – Option button Anti-crease
- 6 – Option button Quick wash
- 7 – Option button Spin speed

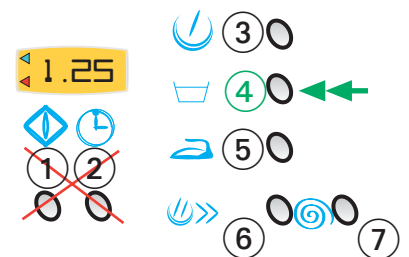

Example 2

- 1 – Option button Start **not usable for the autotest**
- 2 – Option button Prewash – first usable button
- 3 – Option button Quick wash – second usable button – **Used to start the Autotest**
- 4 – Option button Programmed Start **not usable for the autotest**
- 5 – Option button Spin delay
- 6 – Option button Spin speed
- 7 – Option button Anti-crease

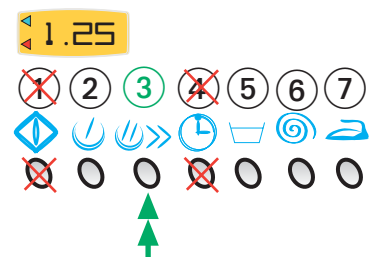

Positions of the button on the various model styles:

Example of an appliance with 1 knob and large LCD display – Model style CG

- 1 Delayed start selector
- 2 Spin speed selector
- 3 Program start selector
- 4 Prewash selector
- 5 Energetic wash selector
- 5 Manual Autotest Selector**
- 6 Extra rinse selector
- 7 Anti-crease selector
- 8 Depending on the model
 - 8.1 Spin delay selector
 - 8.2 Drying selector
 - 8.3 Stain removal selector.

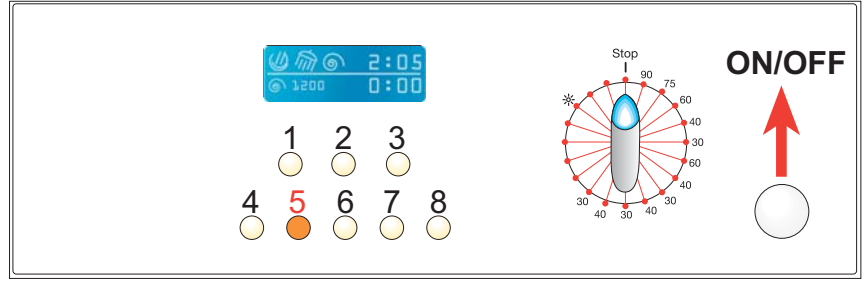

Example of an appliance with 1 knob and large LCD display – Model style CB

- 1 Spin speed selector
- 2 Delayed start selector
- 3 Prewash selector
- 4 Energetic wash selector
- 4 Manual Autotest Selector**
- 5 Extra rinse selector
- 6 Depending on the model
 - 6.1 Anti-crease selector
 - 6.2 Spin delay selector
 - 6.3 Drying selector
 - 6.4 Stain removal selector.
- 7 Program start selector

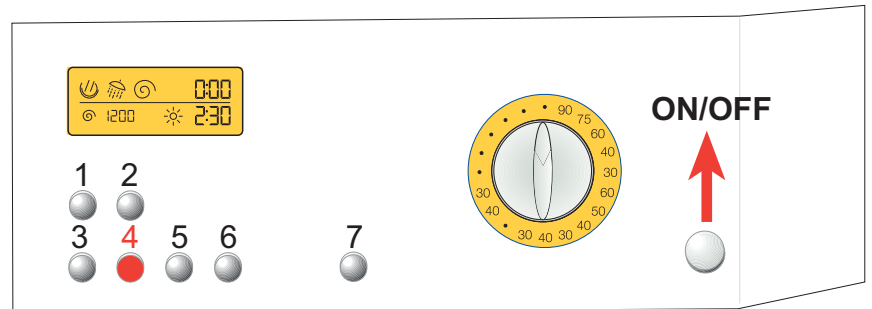

Example of an appliance with 1 knob and no display – Model style CB - CD - CE - CL - CM

- 1 Delayed start selector
- 2 Spin speed selector
- 3 Prewash selector
- 4 Energetic wash selector
- 4 Manual Autotest Selector**
- 5 Extra rinse selector
- 6 Depending on the model
 - 6.1 Anti-crease selector
 - 6.2 Spin delay selector
 - 6.3 Drying selector
 - 6.4 Stain removal selector.
- 7 Program start selector

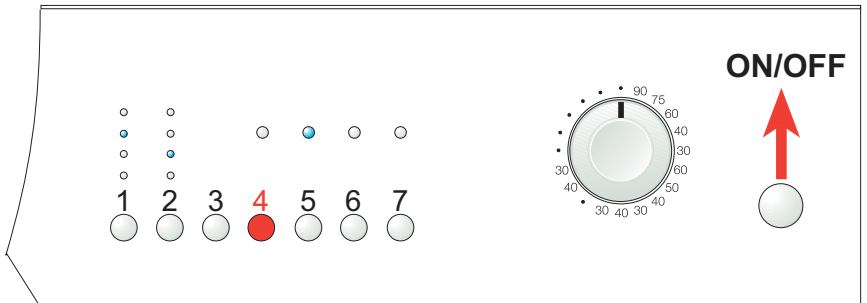

Example of an appliance with 1 knob and large LCD display – Model style CD

- 1 Delayed start selector
- 2 Spin speed selector
- 3 Prewash selector
- 4 Energetic wash selector
- 4 Manual Autotest Selector**
- 5 Extra rinse selector
- 6 Depending on the model
 - 6.1 Anti-crease selector
 - 6.2 Spin delay selector
 - 6.3 Drying selector
 - 6.4 Stain removal selector.
- 7 Program start selector

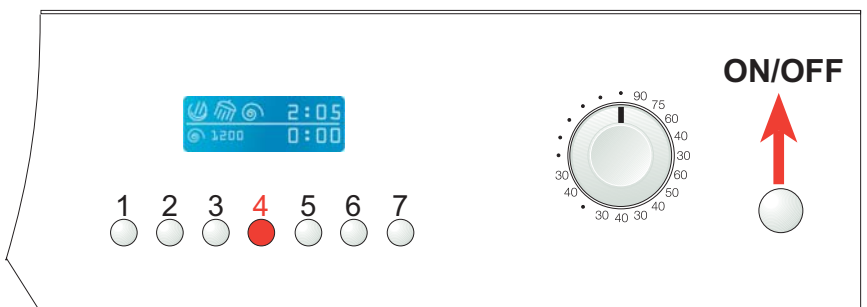

Pushbutton specifications

Description of the functions of the selector buttons:



Delayed start button

This button allows a delayed start to be programmed for a selected wash program. The set delay time is displayed by the timer LCD in hours:minutes (delays possible from 1 to 16 hours) or by the leds above the button (for models without display). The setting is confirmed by pressing the **Start** button, the **Delay** button will then light up to indicate that the function has been activated.

With the timer display at zero, the **Delay** button indicator light will switch off and the **Start** button will light up.

During the delay phase, the **Delay** button remains enabled to allow the delay setting to be modified.
Tasto Ritardo di partenza (Delay)



Spin speed setting button (this button is not illuminated)

The button allows the maximum spin speed to be modified and/or reduced to zero. The set spin speed is displayed by the LCD or by the leds above the button (for models without display). The initial speed setting displayed is the maximum allowed for the set program. The spin speed can also be modified during the wash cycle.

NB: Excluding the spin also excludes the DRYING function (in the case of Washer/driers).



No-spin button

This button allows the spin function to be included or excluded from the wash cycle. The button is not normally lit but lights up when the function has been selected.



Prewash button

This button includes or excludes the prewash (see specifications) from the wash programs that accept the function (see program table in the instruction book).

The button is not normally lit but lights up when the function has been selected.



Energetic wash button

This button includes or excludes the energetic wash (see specifications) from the wash programs that accept the function (see program table in the instruction book).

The button is not normally lit but lights up when the function has been selected.



Extra rinse or extra rinses button (depending on the model)

This button includes or excludes the extra rinses (see specifications) from the wash programs that accept the function (see program table in the instruction book). The button is not normally lit but lights up when the function has been selected.



Anti-crease button

This button includes or excludes the anti-crease function from the wash programs that accept the function (see table in the instruction book).

The button is not normally lit but lights up when the function has been selected.

The anti-crease function limits the maximum spin speed to 800 or 1000 rpm (depending on the model), after which the drum rotates clockwise and anticlockwise at 35 rpm for 30 minutes with cycles of **7 seconds ON and 2 minutes OFF**.

NB: The anti-crease function is disabled when the drying function has been activated



Spin delay

This button includes or excludes the spin delay function from the wash programs that accept the function (see table on the instruction book).

The button is not normally lit but lights up when the function has been selected.

The spin delay function stops the wash cycle at the last rinse and the button indicator light flashes. The appliance will remain in this condition until the flashing button is pressed, after which the light will switch off and the cycle will restart to complete the program.



Dry button

This button is used to select the drying time, which is then displayed by the timer LCD.

The button is not normally lit but lights up when the function has been selected.

!!!

If the spin is not effected due to an unbalanced wash load and the spin function has been selected, the appliance will behave as follows:

- the cycle will stop
- the spin icon will flash
- the drying time will remain programmed
- the start button will flash
- the door catch safety lock will be deactivated.

An explanation of how to distribute the load evenly can be found in the Instruction Book.

When the **Start** button is pressed, the icon and button light will stay on and the cycle will continue with the spin balancing function.



Stain removal button (if fitted to the appliance)

This button allows the stain removal function to be included or excluded from the **60°C COTTON** program.

The button is not normally lit but lights up when the function has been selected.

NB: When the stain removal function is activated, the prewash button is disabled

Stain removal program description

Place the usual detergent in the wash compartment and the special *stain removal* detergent in the prewash compartment.

After the first 10 minutes, the water is heated up to 40°C and the detergent is taken from the main wash compartment.

Once 40°C has been reached, water is fed through the prewash compartment for approximately 10 seconds (*taking with it the stain removal detergent*). The water is then further heated up to 60°C and remains at this temperature for approximately 10 minutes. The wash then continues for a further 40 minutes and then on to the rinses, etc. etc.



Start button

This button confirms the previously set functions and starts the program.

The button is not normally lit, but lights up to indicate the cycle is running only if the door catch is closed. In the version with the LCD, when the program selector is positioned on "**Stop**", the cycle is stopped and the button light switches off.



In the version without a display, when the program selector is positioned on "**Stop**", the cycle is stopped and the button light flashes.

Specifications of the various Liquid Crystal Displays used

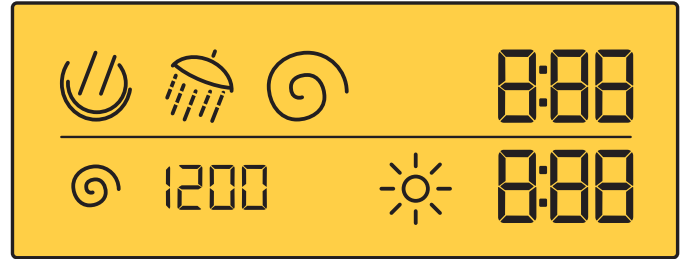
DISPLAY Washer/drier version mod. B



The wash symbols indicate the current phase of the program running:

-  = "Wash" phase
-  = "Rinse" phase
-  = "Spin" phase



Timer display:

- wash time in hours:minutes
- delay time in hours:minutes (settable from 1 to 16 hours in steps of 1 hour)
- end of program indicated by the word **End**
- program reset with symbol - - - flashing



Spin speed and No-spin function:

- The spin symbol is always lit.
- The spin speed can be set from the maximum allowed for the selected program down to **500 rpm** in steps of 100.
- The next press selects the No-spin function and is displayed by "00".

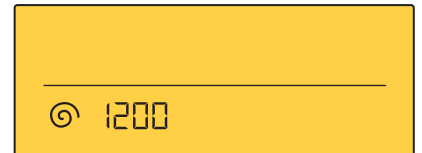

Drying

- The Drying symbol indicates the function has been selected and the drier is heating up.
- During the last 20 minutes (cooling period with heater element switched off), the Drying symbol remains unlit.
- The timer indicates the time in hours:minutes as follows: **20 – 40 – 1:00 – 1:20** followed by **10 minute** steps up to **2:20**.

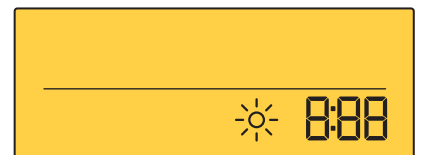

Multifunction DISPLAY model "C".

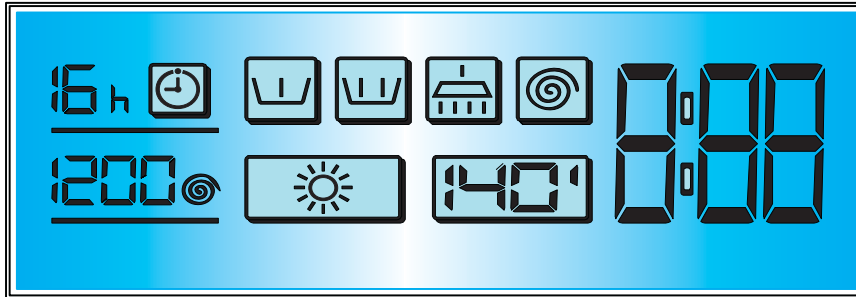

The wash symbols indicate the current phase of the program running:

"Prewash" phase

"Wash" phase

"Rinse" phase

"Spin" phase

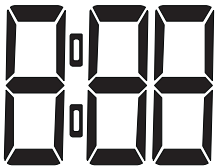

Information displayed by the timer:

- wash time in hours:minutes
- end of program indicated by the word **End**
- program reset with symbol - - - flashing



Delayed Start:

- delay time in hours:minutes (settable from 1 to 16 hours in steps of 1 hour)



Spin speed and No-spin function:

- The spin symbol is always lit.
- The spin speed can be set from the maximum allowed for the selected program down to a minimum of **500 rpm** in steps of 100.
- The next press selects the **No-spin** function and is displayed by "**00**".



Drying (for Washer/driers only).

- The Drying symbol indicates the function has been selected and the drier is heating up.
- During the last 20 minutes (cooling period), the Drying symbol remains unlit.
- The timer indicates the time in hours:minutes as follows: **20 – 40 -60 -80** etc. up to **140'**).



CONTROL PANEL

“Program and Temperature” selector knob

This knob is used to select the type of wash and the most appropriate temperature for the items to be washed.

Positioning the knob at the **"STOP"** position will **reset** the programming of the appliance.

If, for any reason, you want to change the set wash program or add more washing to the load during the

wash cycle, simply place the programmer knob on **"STOP"** (**3 lines - - - will flash on the DISPLAY, or the START button will flash on washing machines without a display**).

Then re-position the knob on the new program and press the **"START"** button.

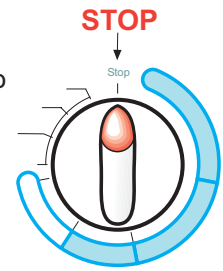

N.B. After carrying out this operation, check that there is detergent in the appropriate compartment and add if necessary.

Warning: Only use this function if strictly necessary and then only if the program to reset has been running for less than 3 minutes. Before opening the door after a reset, wait 2 minutes for the locking mechanism to release.

IMPORTANT:

The time reported on the display is **purely indicative** even though it is updated continuously during the wash cycle. The wash time, in fact, can be influenced by a number of factors:

- Temperature and Pressure of the mains water supply system
- Voltage
- Quantity of washing and types of fabric in the drum.

These electronic appliances are fitted with an **"EASY LOGIC"** system that automatically recognises the quantity of washing placed in the drum. This function regulates the duration of the wash and quantity of water used, thus saving water, time and energy.

In the case where the amount of washing is less than the maximum recommended load (see washing machine instruction book), the quantity of water used for the wash will be reduced in proportion to the wash load.

In the case of a half-load or less, the machine will automatically carry out one rinse less than that programmed.

N.B. The **"EASY LOGIC"** function is only active for cotton programs.

General:

Always start by checking the other components involved, and then check the electronic control unit last.

The following examples are provided assuming that all connections and connectors are in good working order, and that the voltage is within the required limits.

The electronic Control Unit has a self-diagnostics function that checks all the components connected to it, i.e. the so-called Autotest.

MANUAL AUTOTEST

To carry out the test, the following start conditions must be satisfied:

- **The washing machine must be cold and empty. This is very important in that this phase tests both the thermistor and the pressure switch in OFF condition.**

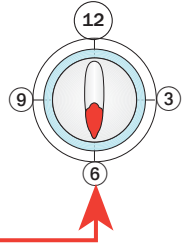

Procedure:

- Set the **wash program selector** knob with the index mark at **6-o-clock (Maximum Ohmic resistance value)**.

For appliances with 2 knobs and no Display:

Taking into account that the **Start** and **Programmed start** buttons cannot be used to start the autotest procedure:

- press the second wash option button at the same time as the **ON/OFF** button.
- set the **Spin speed selector** knob (in the case of a **Washing machine**) or the **Drying timer** knob (in the case of a **Washer/drier**) with the index mark at **9-o-clock** (see following example).

For appliances with one knob and Display:

Taking into account that the **Start** and **Programmed start** buttons cannot be used to start the autotest procedure, press the second wash options button at the same time as the **ON/OFF** button.

Example of an appliance with 2 knobs and without Display

Styling "AKE"
"AW"

Manual Autotest Selector 9-o-clock 6-o-clock ON/OFF

For washer/driers with LCD Display:
 To start the appliance in autotest mode, press button 4 or 5 (according to the styling of the washer/drier) at the same time as pressing the **ON/OFF** button.

Styling "CG"

Manual Autotest Selector 6-o-clock ON/OFF

Styling "CB"

Manual Autotest Selector 6-o-clock ON/OFF

Styling "CD"

Manual Autotest Selector 6-o-clock ON/OFF

Styling 7P-1M
"CD"
"CE"
"CL"
"CM"

Manual Autotest Selector 6-o-clock ON/OFF

S.M.P.E.18.A 01-12-04

AUTOTEST for appliances with small LCD display

The combination **Knob, Function Button, ON/OFF button** starts the Autotest.

The display will light up fully for a few seconds together with some of the buttons.

NB:
The colour used for the display, the buttons and the knob has no significance.

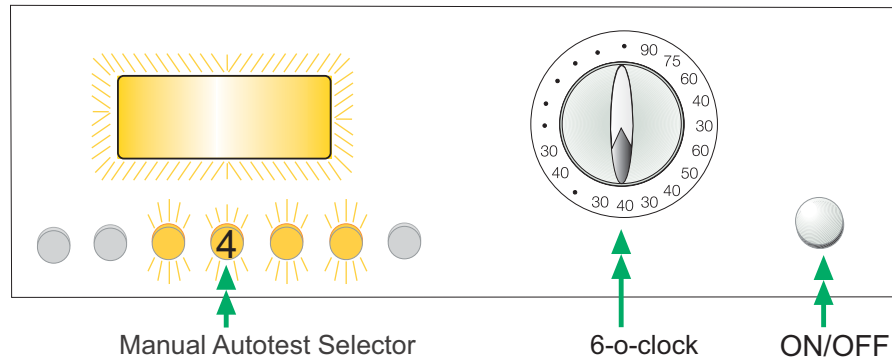

This test will automatically check the following:

- That the **Thermistor** is not in short-circuit or disconnected.
- the **Pressure Switch OFF** condition (no water in tub)
- that the **Door catch** is working properly (contact closed)
- that the **Program selector/Spin speed selector** is connected properly

If the result of the test is positive, all the symbols on the display will light up.

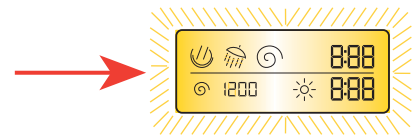

Button illumination test:

- The **Spin speed selection** button is not luminous.
- The **Delayed start** button only lights up when pressed.
- The **Start** button only lights up when pressed.
- All the other buttons change their status from **On** to **Off**, or vice versa, each time they are pressed.

The **spin speed** selection button can change the set rpm at any time if pressed during the test.



N.B.: This button is not luminous.
On some models, the "No Spin" function is disabled during the Autotest phase.

Pressing the **Drying time** selection button (present on washer/driers only) any time during the test changes the hours/minutes setting cyclically.



NB: during this phase, the Drier is not operational, and the button only changes the display.

The **Start** button switches the display wash/dry symbols on and off cyclically.



The programmer knob selects the various phases of the test, which are then displayed by the timer as described in "**Manual Test Selection**".

INTRODUCTION:

The electronic control unit also allows individual components to be tested by varying the knob setting and maintaining the other conditions unchanged. Once the autotest function has been started, the required test can be selected by placing the knob in the appropriate position. Each position of the knob corresponds to a component test.

Starting from the start position (**6-o'clock**) and rotating the knob anticlockwise one position at a time there are **six** tests (for Washer/driers) and **5** tests (for Washing machines) that can be carried out. Except for the first test, which is carried out by the control unit itself, in order to verify the result of the test, the behaviour of each tested component must be monitored..

The control unit takes a few seconds to pass from one test to the next. The acceptance of the test is signalled by the leds switching off or by a display code indicating the program corresponding to the position of the knob in autotest. From this point on, all the suspect components can be tested.

The correspondence between the reference position of the knob and a wash program is purely indicative, in that this is linked to the appliance model in question.

The combination **Knob, Function Button, ON/OFF button** starts the Autotest.

The large LCD display will light up fully for a few seconds together with some of the buttons.

NB:
The colour used for the display, the buttons and the knob has no significance.

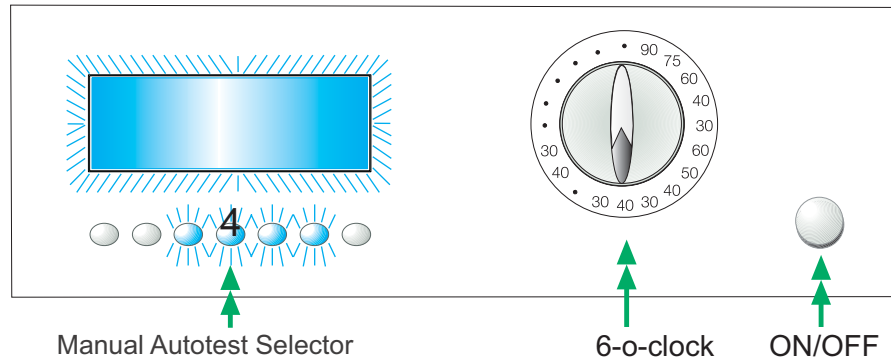

This test will automatically check the following:

- That the **Thermistor** is not in short-circuit or disconnected.
- the **Pressure Switch OFF** condition (no water in tub)
- that the **Door catch** is working properly (contact closed)
- that the **Program selector/Spin speed selector** is connected properly

If the result of the test is positive, all the symbols on the display will light up.

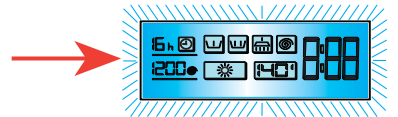

Button illumination test:

- The **Spin speed selection** button is not luminous.
- The **Delayed start** button only lights up when pressed.
- The **Start** button only lights up when pressed.
- All the other buttons change their status from **On** to **Off**, or vice versa, each time they are pressed.

Pressing the **Delayed start** selection button any time during the test changes the hours setting.



NB: During this phase, the **Delayed start** function is not operational, the button only changes the display.

Pressing the **spin speed** selection button at any time during the test changes the set rpm.



Pressing the **Drying time** selection button (present on washer/driers only) any time during the test changes the minutes setting cyclically until the timer is totally excluded from the display.



NB: during this phase, the Drier is not operational, and the button only changes the display.

Pressing the **Start** button switches the display wash/dry symbols on and off cyclically.



The programmer knob selects the various phases of the test, which are then displayed by the timer as described in "**Manual Test Selection**".

INTRODUCTION:

The electronic control unit also allows individual components to be tested by varying the knob setting and maintaining the other conditions unchanged.

Once the autotest function has been started, the required test can be selected by placing the knob in the appropriate position. Each position of the knob corresponds to a component test.

Starting from the start position (**6-o'clock**) and rotating the knob anticlockwise one position at a time there are **six** tests (for Washer/driers) and **5** tests (for Washing machines) that can be carried out. Except for the first test, which is carried out by the control unit itself, in order to verify the result of the test, the behaviour of each tested component must be monitored.

The control unit takes a few seconds to pass from one test to the next. The start of the test is signalled by the appearance of the code on the display indicating the program corresponding to the position of the knob.

DIAGNOSTICS TABLE

Summary table of the tests that can be carried out on appliances with a **Large LCD Display** and fitted with **Thermistors** or **Solenoid valves**.

Possible displays according to the appliance model under test.

Position of knob index mark

Test N° 1

(common to both versions)

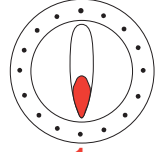
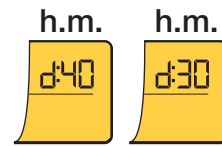
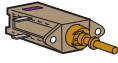

6-o'clock position

Start position, all the functions are deactivated.

The control unit automatically tests the operation of the **thermistor**, the **pressure switch OFF** condition (no water in tub), the **program selector** and the **door catch** closed condition.

Test N° 2

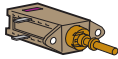

Version with thermo-actuators:
- Fills with water through the cold solenoid valve until the pressure switch trips in.
- Actuator A and actuator B are OFF (water enters the prewash detergent dispenser)

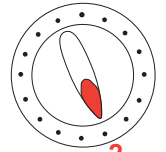
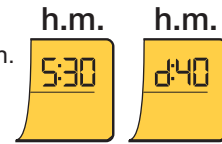

Version with solenoid valves
- Fills with water through the cold solenoid valve until the first pressure switch level is reached.

This procedure tests the operation of the **solenoid valves** and **pressure switch**.

Test N° 3

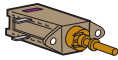

Version with thermo-actuators:
- The heater element is activated (only with water)
- The motor rotates alternately in both directions (clockwise and anticlockwise).
- Thermo-actuator A (wash) is activated.

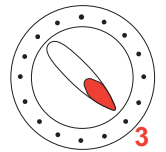
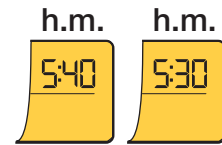

Version with solenoid valves
- The heater element is activated (only with water)
- The motor rotates alternately in both directions (clockwise and anticlockwise).

This procedure tests the operation of the **heater element**, the **motor** during washing and **thermo-actuator A** (where fitted).

Test N° 4

N.B.: In Autotest, on some models the "No Spin" function is disabled.

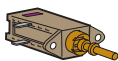

Version with thermo-actuators:
- The drain pump is activated and the spin runs at the preset speed.
- Thermo-actuator B (conditioner) is activated.

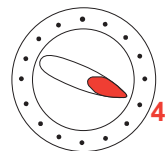
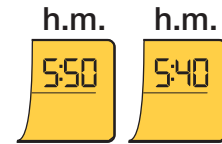

Version with solenoid valves
- The drain pump is activated and the spin runs at the preset speed.

This procedure tests the operation of the **drain pump**, the **motor** in spin mode and **thermo-actuator B** (where fitted).

Test N° 5

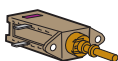

Version with thermo-actuators:
- Fills with water for 10 seconds through the hot solenoid valve, where fitted (only with pressure switch off), wash motor operation at different rpm and direction according to the model of electronic circuit board fitted to the appliance.
- Actuator A and actuator B are ON (water enters the conditioner dispenser)

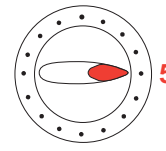
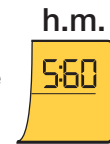

Version with solenoid valves
- Fills with water for 10 seconds through the hot solenoid valve, where fitted (only with pressure switch off), wash motor operation at different rpm and direction according to the model of electronic circuit board fitted to the appliance.

This procedure tests the operation of the **hot water solenoid valve** (where fitted and only with pressure switch OFF) and the **motor** during washing.

Test N° 6

(common to both versions of the Washer/drier)

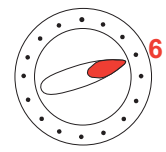
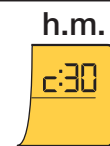
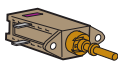

This procedure tests the operation of the **Drying solenoid valve**, the **drying fan motor** and the **drying heater element**.

MANUAL AUTOTEST FOR MINI-SEL MODEL CIRCUIT BOARDS

For model styling with 1 knob control panel and small Display

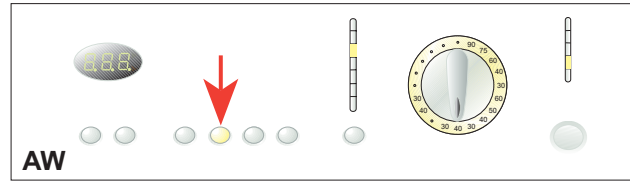
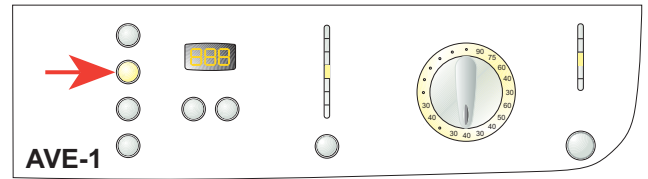
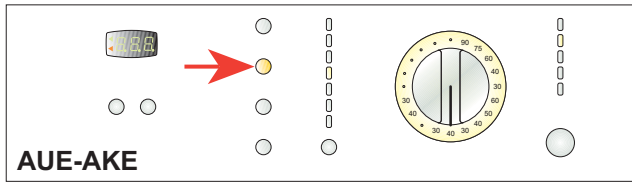

START CONDITIONS FOR AUTOMATIC SELF-TEST

- Set the **Programmer Knob** at **6-o-clock**.
- Keep the **PREWASH** button pressed and at the same time switch the machine on by pressing the **On/Off** button.

- All the lights on the control panel will light up
- The display is fully lit.

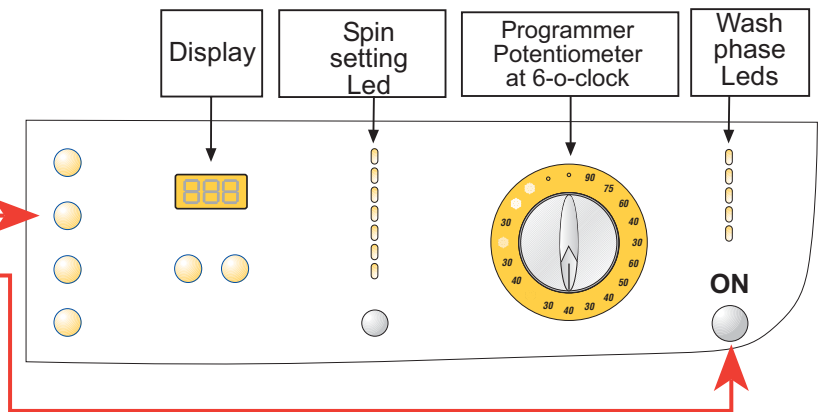

The five LEDS indicating the wash phases will LIGHT UP.

- THE TEST CHECKS
- that the **thermistor** is working properly
 - the **Pressure Switch OFF** condition (no water in tub)
 - that the **Door catch** is working properly (contact closed)
 - **Program selector/Spin speed selector**

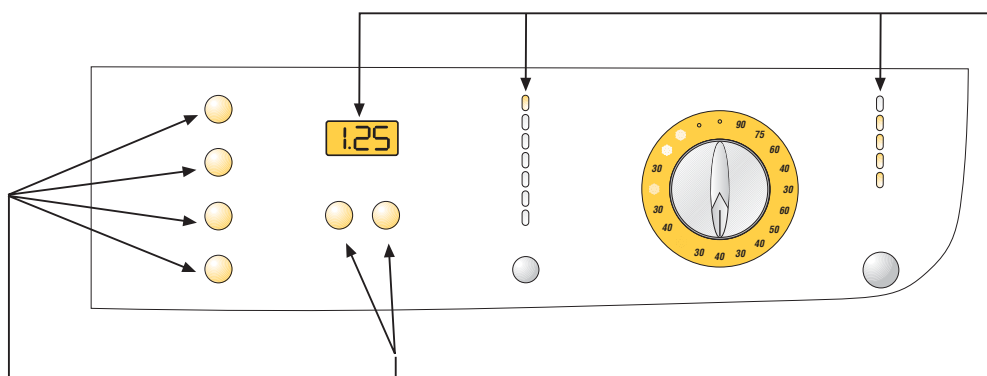

If the results of these checks are positive, the top LED will switch off and the DISPLAY will indicate 1.25.

The luminous buttons change their status from **On** to **Off** or vice versa, each time they are pressed.

Except for the **"START"** and **"DELAY START"** buttons which control the two triangular indicators of the DISPLAY, or which control the illumination of the buttons themselves in the case of a display without luminous triangular indicators.

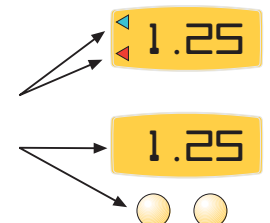

All the speed indicators will switch off except for the set speed indicator.

At this point, the test can be continued using the programmer knob as explained in chapter **MANUAL TEST SELECTION FOR APPLIANCES:**

- with on knob and small display;
- with two knobs and without display

For model styling with 2 knob control panels

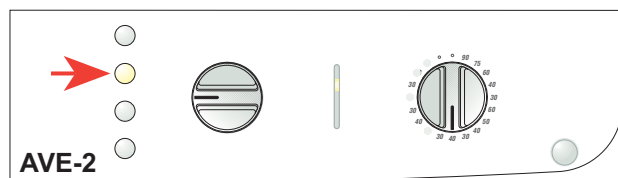
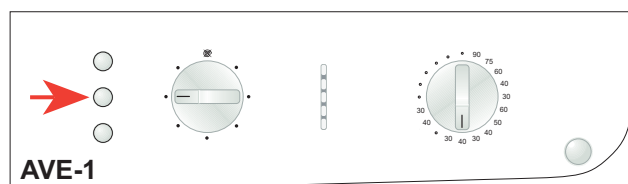
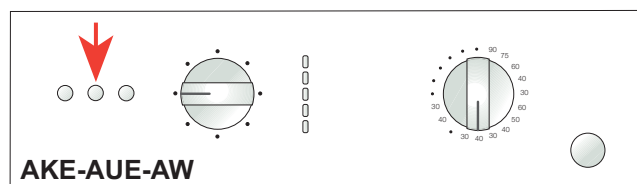

START CONDITIONS FOR AUTOMATIC SELF-TEST

- Set the **Programmer Knob** at **6-o-clock**.
- Set the **Spin Speed Knob** at **9-o-clock**.
- Keep the **PREWASH** button pressed and **at the same time** switch the machine on by pressing the **On/Off** button.

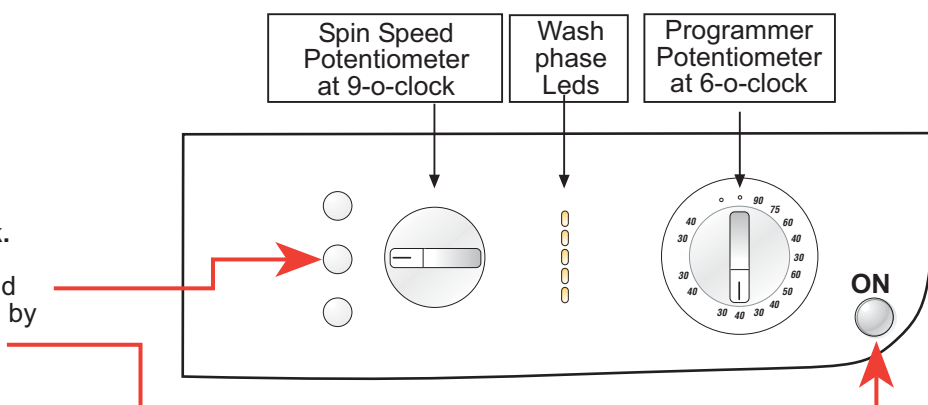

The five LEDs indicating the wash phases will LIGHT UP.

THE TEST CHECKS

- that the **thermistor** is working properly
- the **Pressure Switch OFF** condition (no water in tub)
- that the **Door catch** is working properly (contact closed)
- **Program selector/Spin speed selector**

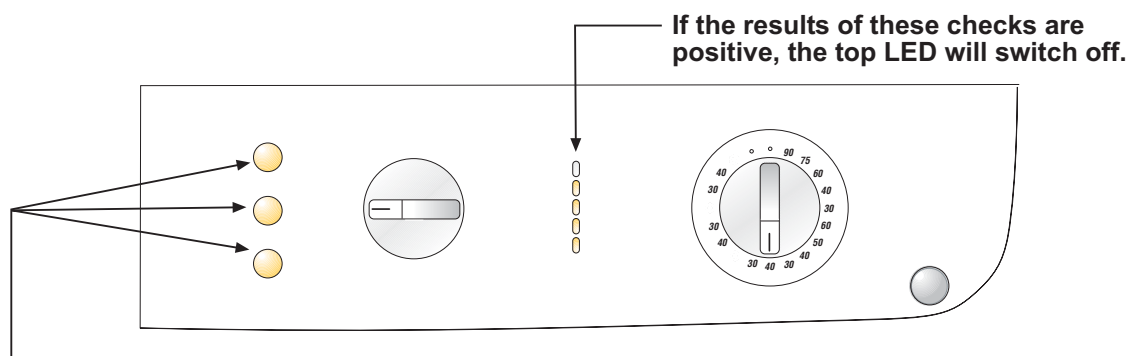

The luminous buttons change their status from **On** to **Off** or vice versa, each time they are pressed. The only exception is the **"START"** button which only stays lit when pressed.

At this point, the test can be continued using the programmer knob as explained in chapter

MANUAL TEST SELECTION FOR APPLIANCES:

- with on knob and small display;
- with two knobs and without display

- For model styling with **1 knob control panel and small Display**
- For model styling with **2 knob control panels without display**

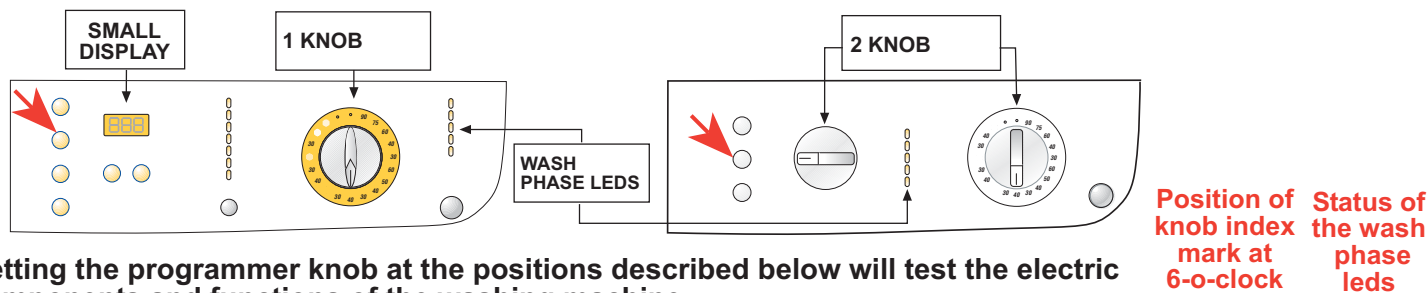

Setting the programmer knob at the positions described below will test the electric components and functions of the washing machine.

Test N° 1

(common to both versions)

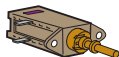

- Start position, all the functions are deactivated.



The control unit automatically tests the operation of the **thermistor**, the **pressure switch OFF** condition (no water in tub), the **program selector** and the **door catch** closed condition.

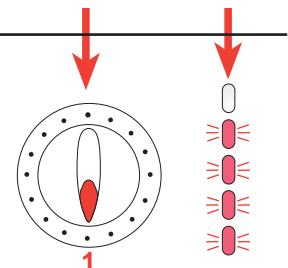

Test N° 2

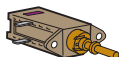

Version with thermo-actuators:
 - Fills with water through the cold solenoid valve until the pressure switch trips in.
 - Actuator A and actuator B are OFF (water enters the prewash detergent dispenser)



Version with solenoid valves
 - Fills with water through the cold solenoid valve until the first pressure switch level is reached.

This procedure tests the operation of the **solenoid valves** and **pressure switch**.

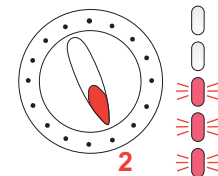

Test N° 3

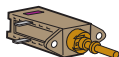

Version with thermo-actuators:
 - The heater element is activated (only with water)
 - The motor rotates alternately in both directions (clockwise and anticlockwise).
 - Thermo-actuator A (wash) is activated.



Version with solenoid valves
 - The heater element is activated (only with water)
 - The motor rotates alternately in both directions (clockwise and anticlockwise).

This procedure tests the operation of the **heater element**, the **motor** during washing and thermo-actuator A (where fitted).

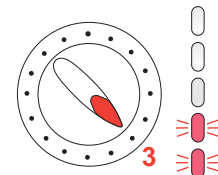

Test N° 4

N.B.: In Autotest, on some models the "No Spin" function is disabled.

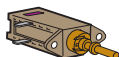

Version with thermo-actuators:
 - The drain pump is activated and the spin runs at the set speed.
 - Thermo-actuator B (conditioner) is activated.



Version with solenoid valves
 - The drain pump is activated and the spin runs at the set speed.

This procedure tests the operation of the **drain pump**, the **motor** in spin mode and thermo-actuator B (where fitted).

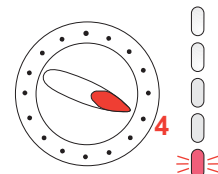

Test N° 5

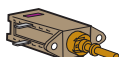

Version with thermo-actuators:
 - Fills with water for 10 seconds through the hot solenoid valve, where fitted (only with pressure switch off), wash motor operation at different rpm and direction according to the model of electronic circuit board fitted to the appliance.
 - Actuator A and actuator B are ON (water enters the conditioner dispenser)



Version with solenoid valves
 - Fills with water for 10 seconds through the hot solenoid valve, where fitted (only with pressure switch OFF), wash motor operation at different rpm and direction according to the model of electronic circuit board fitted to the appliance.

This procedure tests the operation of the **hot water solenoid valve** (where fitted and only with pressure switch OFF) and the **motor** during washing.

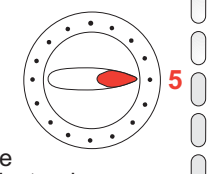

Test N° 6

(common to both versions of the Washer/drier)

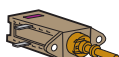

This procedure tests the operation of the **Drying solenoid valve**, the **drying fan motor** and the **drying heater element**.

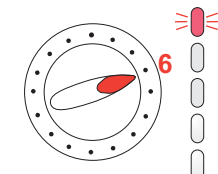

TROUBLESHOOTING GUIDE

Before carrying out any operations on a component check the quality of the electrical connections to the electronic control unit.

Check the condition of the wiring harness (for wear, twists, breakages) and the connections.

Always start by checking the other components involved, and then check the electronic control unit last.

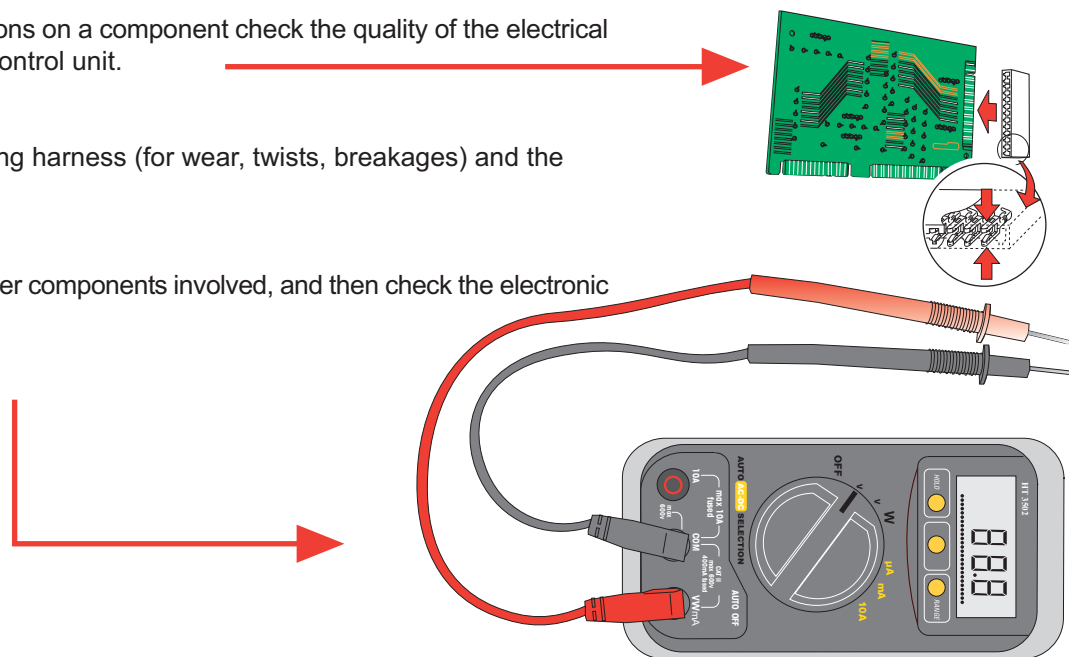

The program will not start.

Try the Manual Autotest

A) If the appliance **DOES NOT** enter autotest mode, recognisable by the following components **not lighting up**:

- **Leds** (for appliances with a small display and 1 knob or 2 knobs without display).
 - **Large LCD display** for appliances fitted with same.
- then the following checks must be carried out:

- Check that the electrical connections of the Potentiometer are correct and according to the wiring diagram, that the component is undamaged and in working order, otherwise replace the component.
- Check that the electrical connections of the pushbutton circuit board are inserted correctly. If so, and the problem persists, replace the pushbutton circuit board. Finally, if this doesn't solve the problem, replace the main electronic control unit.

B) If the appliance **ENTERS** autotest mode, depending on the type of appliance, the following components will light up:

- 1) For appliances with small display and 1 knob or 2 knobs and no display, **the wash phase leds will all remain lit.**
- 2) For appliances with a large LCD display, **the display illumination will be minus graphics.**

If this occurs, it means that the control unit has discovered a malfunction in one of the three components that it is testing:

- the **thermistor**.
- the **pressure switch**
- the **door catch**

To check the operation of the thermistor:

- Disconnect the wiring from the thermistor and use a multimeter (Tester) to check the ohmic resistance, which should be approximately 5 kOhm at an ambient temperature of 25°C,
- if the result is positive, check the Pressure switch.
- if the result is negative, replace the Thermistor.

To check the operation of the Pressure switch:

- Disconnect the electrical wiring from the Pressure switch and check that contact P11-P14 is open,
- if the result is positive, check the Door catch.
- If the result is negative, check that the pressure switch pipe and the compression chamber are not blocked. if these are OK, replace the Pressure switch.

To check the operation of the Door catch:

- Check that connections **BP1**, **BP2** and **BP3** have been properly made.
- Use a Tester to check the voltage between contact **BP3** and **BP1**.
- if the test result is positive, replace the component
- if there is no voltage, replace the electronic control unit.

Once this procedure has been completed, the problem should have been resolved and the appliance should work properly.

DIAGNOSTICS TABLE

Water does not enter the tub.

Check that the water feed valve to the washing machine is open.

Start the manual Autotest procedure, then carry out **Test N° 2**. If water still does not enter the tub, use a Tester to carry out the following checks:

- check that there is continuity between the two terminals of the solenoid valve, if the circuit is open replace the component.
 - check that there is voltage at the ends of the wires connecting the solenoid valve to the control unit. If there is no voltage, replace the electronic control unit.
-

The washing machine does not heat the water in the tub.

Start the manual Autotest procedure, then carry out **Test N° 2** to fill the tub with water (this is necessary in order to allow the heater element to work). On completion of this operation, carry out **Test N° 3**. If the water is still not heated, use a Tester to carry out the following checks:

- check that the heater element circuit is no broken (Ohms). If the circuit is open, replace the component.
 - check that there is continuity between the two contacts of the T90° safety thermostat, if the circuit is open replace the component.
 - check that there is voltage at the ends of the wires connecting the heater element to the control unit. If there is no voltage, replace the electronic control unit.
-

The motor does not turn properly during a wash and/or spin

Start the manual Autotest procedure and then carry out **Test N° 3**.

- Check that the motor rotates alternately in both directions (clockwise and anticlockwise) at approximately 45 rpm. If the result is positive, carry out **Test N° 4**.
If the test is negative, disconnect the motor from the wiring terminal board, then use a Tester to check that there is continuity at the ends of the wires connecting the wiring terminal board to the control unit. Then check that the connectors are not damaged or disconnected.
 - Replace the motor with one known to be in working order. If the result of the test is positive, replace the motor. If the result is negative, replace the electronic control unit and refit the original motor.
-

The washer/drier does not drain

Check that the washer/drier filter or the user's drains are not blocked.

Start the appliance in manual Autotest mode and move the programmer knob to the **Test N° 2** position. Wait for the pressure switch to trip and then carry out **Test N° 4**:

If the result is negative, disconnect the pump wiring and check that the circuit is no broken (Ohms). If the circuit is open, replace the electric pump.

- if the circuit is closed, remove the pump from the washing machine and use a screwdriver to check for any foreign bodies in the scroll.
- use a tester to check the continuity in the pump power supply wires. If all the tests carried out prove positive replace the control unit.

DIAGNOSTICS TABLE

Water flows into the tub continuously.

- Check that the **solenoid valve** is not damaged (water should not enter the tub when the appliance is switched off).
 - Check that the **pressure switch** is working by carrying out **Test N° 2**.
 - Check that **Pressure switch** contact **P11- P14** is closed, allow this phase of the test to continue for a few minutes, then make sure that there are no air leaks.
 - Check that there are no leaks from the gaskets, rubber couplings or tub unit.
 - Check that the pressure switch pipe is not holed or bent.
 - If all the above tests result positive, replace the electronic control unit.
-

The drier does not dry (in the case of washer/driers only)

Carry out **Test N° 6**. If the result is negative, carry out the following checks:

- Check that the **Safety thermostat** (with Manual Reset) has not tripped, and that the contact of the **Long stem thermostat**, is normally closed.
- Check that the heater element circuit is no broken (Ohms). If the circuit is open, replace the component.
- Use a Tester to check that there is continuity at the terminals of the **Drier heater element** wiring.
 - If voltage is present, replace this component.
 - If there is no voltage, replace the drying electronic control unit.
- Check that the **Drying fan motor** circuit is no broken (Ohms). If the circuit is open, replace the component.
- Use a Tester to check that there is voltage at the terminals of the **Drying fan motor** wiring.
 - if there is voltage present, check that the motor fan has not been blocked by a foreign body.
 - If there is no voltage, replace the drying electronic control unit.
- Check that the **Drain Pump** is working properly by carrying out **Test N° 4**.

NB: In the case where, excessive steam is generated during a drying cycle, check that the drying solenoid valve is working properly by carrying out **Test N° 6**. If the result of the test is negative, check that there is continuity between the two terminals of the solenoid valve (Ohms). If the circuit is open, replace the component.

SAFETY measures adopted in the electronic control unit software.

- Motor rotor jammed or Tachometric open.

After eight failed attempts to start the motor (either in wash or spin mode), the control unit passes to the end of the cycle and the **End** led flashes on appliances without a display or the word **End** appears on appliances with a display.

- Drain Pump blocked.

If the control unit does not detect the pressure switch empty condition after twenty minutes of pump running time, it passes to the next step and continues the cycle until the end of the program, stopping with water still in the tub.

- Thermistor or thermostat malfunction

If, after fifty minutes of heater element operation the set temperature has not been reached, the control unit advances and continues the cycle as normal, though with cold water.