



Service Manual Professional Washing Machine

Type: WM70.C

Contents

Updates.....	4
Introduction	5
General product information.....	6
Troubleshooting strategy	8
Faults and measures	10
Panel.....	11
Knob and button descriptions.....	11
Display description.....	11
Programme tables	12
Programme descriptions	16
Settings.....	17
Service menu	18
Service menu content.....	19
Notes for custom programmes	21
Making a custom programme.....	22
Fault indicators	24
Components and measurement values.....	25
Thermistor measurement values.....	25
Technical data.....	26
Tools.....	26
Wiring diagram	27
Panel and control card replacement.....	28
Wash agitator removal	30

Updates

Rev	Date	Description	Initials
01	2010-07-12	First version developed	BPA

Introduction

You are holding the service manual for WM70.C washing machines.

It should be easy to service a washing machine. It is important that you, as a service technician, are provided the necessary conditions to work in an efficient and satisfactory manner. Our hope is that this service manual will prove a useful tool in your daily work.

The type plate is located on the inside of the front door (see image below).

Asko Appliances AB
SE-534 82 Vara
Sweden



Type designation

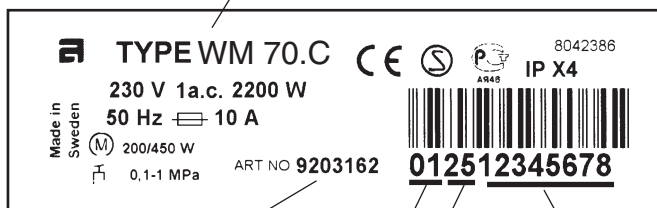

Product number

Year Week

Serial number

General product information

In conjunction with the introduction of the WM70.C (August 2010), our washing machines have been altered in a number of areas. Here we present the changes to the wash drum and wash agitators.

- Larger wash drum:
 - 60 litres (previously 50 litres)
 - 23 mm deeper, the drum is now 343 mm deep in total (previously 320 mm)
 - 30 mm larger diameter, 480 mm in total (previously 450 mm)
- New drum hole pattern to cause as little wear as possible on clothing.
- New agitators that improve the wash process.

All cylinder holes flanged to reduce wear on textiles.

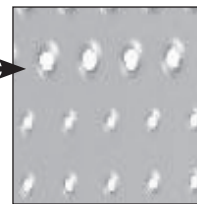

Area with large holes (3.7 mm) to remove larger objects, such as grit.

Area with smaller holes (2.2 mm) to reduce wear on textiles.

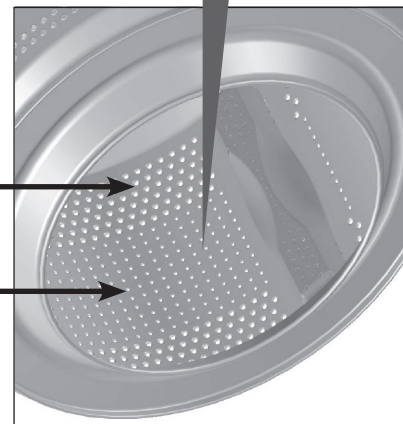

The angle of the edge of the cylinder, combined with the shape of the agitators, moves the load towards the middle of the drum. This improves drum balance and reduces wear on textiles.

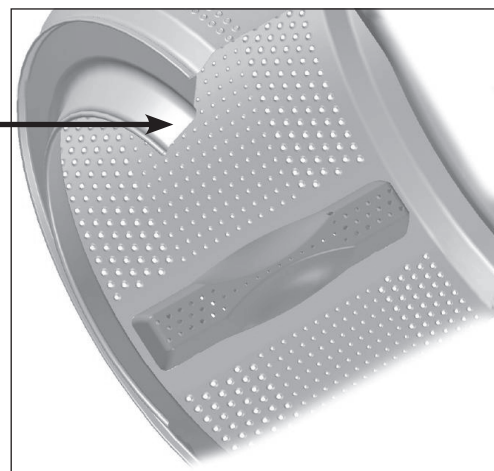

Hourglass-shaped agitators:

- Move the load towards the smaller, gentler holes in the middle of the drum.
- Move larger objects, such as grit, towards the larger holes at the edges of the drum.

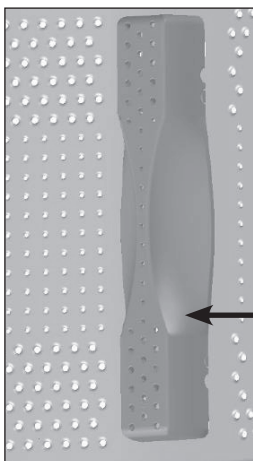

General product information (cont.)

- Automatic detergent compartment cleaning
 - Cleaned after every ten wash cycles between the main wash and the first rinse.
- Ready for automatic dosing

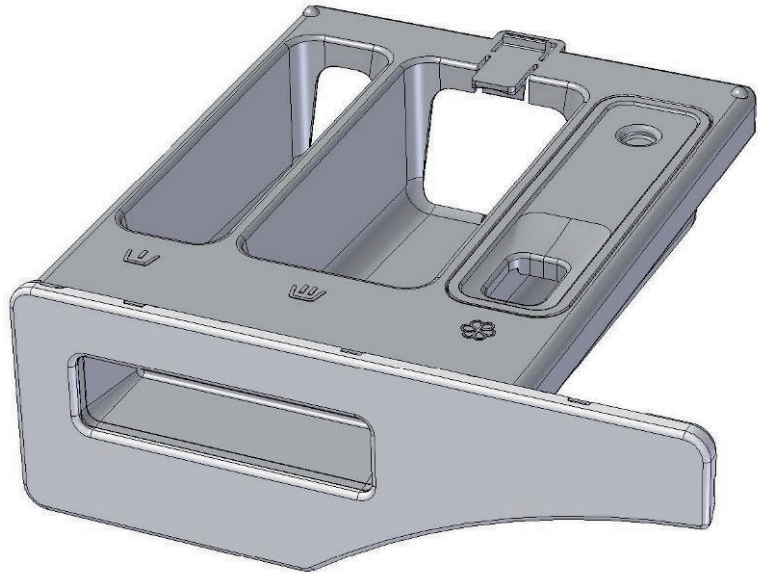

Troubleshooting strategy

At Asko, we believe in always remaining focused on the customer, and as an ASKO service technician, you are one of the most important ambassadors of our brand. As such, it is important that the customer finds the service callout a pleasant experience. Troubleshooting is an important part of the service callout, and as such we have drawn up a troubleshooting strategy that describes, in broad terms and step by step, what you need to do to find and diagnose faults.

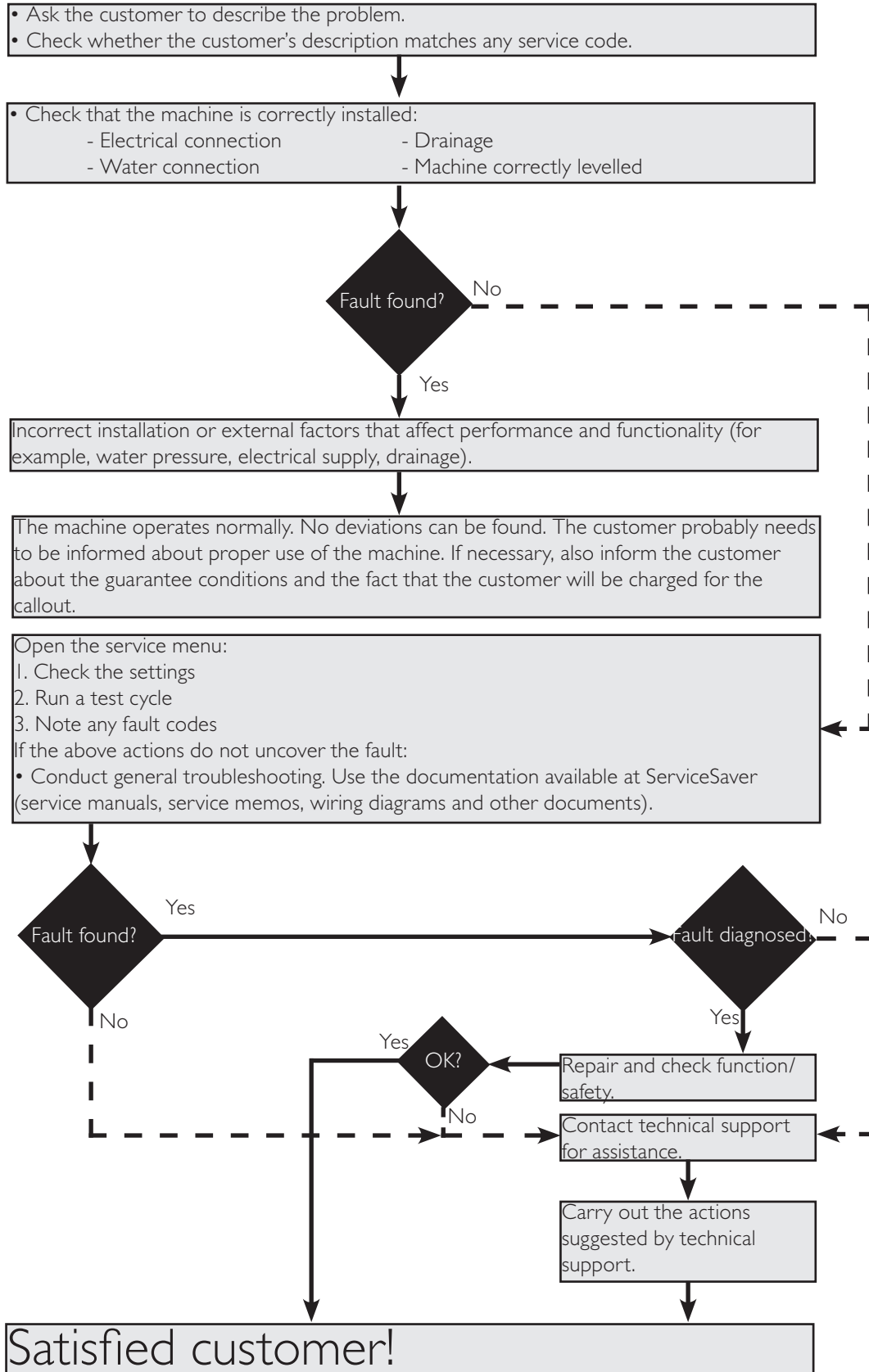

Panel WM70.C



Programmes: A total of twenty-two programmes, three of which can be customised via the service menu. A maximum of ten programmes can be activated/available to the end user at the same time.

Settings: Four (Language, Child-safe start, Automatic door opening, Temperature)

Knob and button descriptions

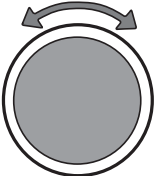
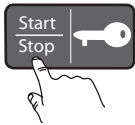
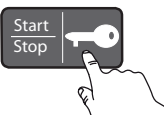
	<p>Programme selector Turn clockwise or anti-clockwise to cycle through the different programmes and options in the various menus.</p>
	<p>Start/Stop button</p> <ul style="list-style-type: none"> • Start programme • Stop programme. Press and hold for 3 seconds.
	<p>Key button</p> <ul style="list-style-type: none"> • Opens the door once the programme has ended. • Opens the door during a programme to add more laundry. • Confirm selection in the settings and service menus.

LCD description

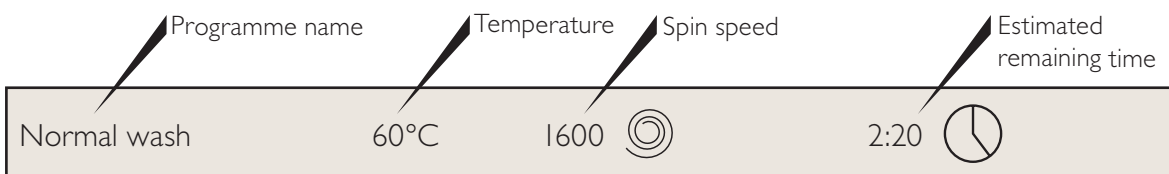

Programme tables

The tables present a few examples of the energy, water and time consumption of a few different programmes. Consumption can vary depending on water pressure, water hardness, water supply temperature, room temperature, the type and amount of laundry, and variations in the power supply. The stated times are approximate.

Machine connected to cold water, 6 kg

Programme	Degree of filling (kg)	Spin (rpm)	Time (min)	Energy consumption (kWh)	Water consumption	Rinses
1. Normal wash 60°C * Programme for labelling (also standard programme for Swan-labelled machines)	6 kg cotton	Max.	158	1.14	80	5
2. Normal wash 40°C Programme for labelling (also standard programme for Swan-labelled machines)	6 kg cotton	Max.	150	0.65	80	5
3. Heavy wash 90°C	6 kg cotton	Max.	85	2.05	75	3
4. Heavy wash 60°C	6 kg cotton	Max.	65	1.20	65	3
5. White wash 90°C	6 kg cotton	Max.	70	1.70	65	3
6. White/Colour wash 60°C	6 kg cotton	Max.	60	0.80	60	3
7. White/Colour wash 40°C	6 kg cotton	Max.	55	0.50	60	3
8. Super quick wash 60°C	3 kg cotton	800	30	0.60	40	3
9. Super quick wash 40°C	3 kg cotton	800	25	0.35	40	3
10. Synthetics 40°C	3 kg synthetics	800	25	0.30	40	3
11. Wool/hand 30°C	2 kg wool	800	30	0.35	60	3
12. Rinse programme	3 kg cotton	Max.	15	0.10	15	1
13. MOP wash 90°C	6 kg cotton	Max.	65	1.70	50	2
14. MOP wash 60°C	6 kg cotton	Max.	45	0.85	45	2
15. Micro fibre wash 60°C	6 kg cotton	Max.	50	0.80	50	3
16. Micro fibre wash 40°C	6 kg cotton	Max.	45	0.45	50	3
17. Disinfection 40°C	6 kg cotton	Max.	70	0.75	70	3
18. Disinfection 60°C	6 kg cotton	Max.	80	1.35	70	3
19. Disinfection 90°C	6 kg cotton	Max.	100	2.30	80	3
20. Programme A	Custom					
21. Programme B	Custom					
22. Programme C	Custom					

*Programme tested in accordance with EN 60456/A11/A12/.

Programme tables (cont.)

Machine attached to hot and cold water, 6 kg

Programme	Degree of filling (kg)	Spin (rpm)	Time (min)	Energy consumption (kWh)	Water consumption (hot/cold)		Rinses
1. Normal wash 60°C * Programme for labelling (also standard programme for Swan-labelled machines)	6 kg cotton	Max.	158	1.14	0	80	5
2. Normal wash 40°C Programme for labelling (also standard programme for Swan-labelled machines)	6 kg cotton	Max.	150	0.65	0	80	5
3. Heavy wash 90°C	6 kg cotton	Max.	80	1.80	6	69	3
4. Heavy wash 60°C	6 kg cotton	Max.	60	0.95	6	59	3
5. White wash 90°C	6 kg cotton	Max.	58	1.10	16	49	3
6. White/Colour wash 60°C	6 kg cotton	Max.	48	0.20	16	44	3
7. White/Colour wash 40°C	6 kg cotton	Max.	50	0.25	12	48	3
8. Super quick wash 60°C	3 kg cotton	800	27	0.45	10	30	3
9. Super quick wash 40°C	3 kg cotton	800	22	0.20	6	34	3
10. Synthetics 40°C	3 kg synthetics	800	23	0.20	5	35	3
11. Wool/hand 30°C	2 kg wool	800	30	0.35	0	60	3
12. Rinse programme	3 kg cotton	Max.	15	0.10	0	15	1
13. MOP wash 90°C	6 kg cotton	Max.	53	1.10	16	34	2
14. MOP wash 60°C	6 kg cotton	Max.	33	0.25	16	29	2
15. Micro fibre wash 60°C	6 kg cotton	Max.	38	0.20	16	34	3
16. Micro fibre wash 40°C	6 kg cotton	Max.	40	0.20	12	38	3
17. Disinfection 40°C	6 kg cotton	Max.	65	0.50	6	64	3
18. Disinfection 60°C	6 kg cotton	Max.	75	1.10	6	64	3
19. Disinfection 90°C	6 kg cotton	Max.	95	2.05	6	74	3
20. Programme A	Custom						
21. Programme B	Custom						
22. Programme C	Custom						

*Programme tested in accordance with EN 60456/A11/A12/.

Programme tables (cont.)

Machine connected to cold water, 8 kg

Programme	Degree of filling (kg)	Spin (rpm)	Time (min)	Energy consumption (kWh)	Water consumption	Rinses
1. Normal wash 60°C * Programme for labelling (also standard programme for Swan-labelled machines)	8 kg cotton	Max.	185	1.20	82	5
2. Normal wash 40°C Programme for labelling (also standard programme for Swan-labelled machines)	8 kg cotton	Max.	175	0.70	82	5
3. Heavy wash 90°C	8 kg cotton	Max.	100	2.60	80	3
4. Heavy wash 60°C	8 kg cotton	Max.	80	1.40	70	3
5. White wash 90°C	8 kg cotton	Max.	75	1.95	70	3
6. White/Colour wash 60°C	8 kg cotton	Max.	60	1.05	65	3
7. White/Colour wash 40°C	8 kg cotton	Max.	55	0.75	65	3
8. Super quick wash 60°C	4 kg cotton	800	35	0.80	45	3
9. Super quick wash 40°C	4 kg cotton	800	30	0.55	40	3
10. Synthetics 40°C	4 kg cotton	800	25	0.35	45	3
11. Wool/hand 30°C	3 kg wool	800	30	0.35	60	3
12. Rinse programme	4 kg cotton	Max.	15	0.10	20	1
13. MOP wash 90°C	8 kg cotton	Max.	70	1.90	55	2
14. MOP wash 60°C	8 kg cotton	Max.	50	1.00	50	2
15. Micro fibre wash 60°C	8 kg cotton	Max.	60	1.00	55	3
16. Micro fibre wash 40°C	8 kg cotton	Max.	55	0.65	55	3
17. Disinfection 40°C	8 kg cotton	Max.	80	0.95	75	3
18. Disinfection 60°C	8 kg cotton	Max.	90	1.75	75	3
19. Disinfection 90°C	8 kg cotton	Max.	110	2.90	85	3
20. Programme A	Custom					
21. Programme B	Custom					
22. Programme C	Custom					

*Programme tested in accordance with EN 60456/A11/A12/.

Programme tables (cont.)

Machine attached to hot and cold water, 8 kg

Programme	Degree of filling (kg)	Spin (rpm)	Time (min)	Energy consumption (kWh)	Water consumption (hot/cold)		Rinses
1. Normal wash 60°C * Programme for labelling (also standard programme for Swan-labelled machines)	8 kg cotton	Max.	185	1.20	0	82	5
2. Normal wash 40°C Programme for labelling (also standard programme for Swan-labelled machines)	8 kg cotton	Max.	175	0.70	0	82	5
3. Heavy wash 90°C	8 kg cotton	Max.	95	2.35	7	73	3
4. Heavy wash 60°C	8 kg cotton	Max.	75	1.15	7	63	3
5. White wash 90°C	8 kg cotton	Max.	58	1.35	18	52	3
6. White/Colour wash 60°C	8 kg cotton	Max.	48	0.30	18	47	3
7. White/Colour wash 40°C	8 kg cotton	Max.	50	0.30	14	51	3
8. Super quick wash 60°C	4 kg cotton	800	30	0.60	12	33	3
9. Super quick wash 40°C	4 kg cotton	800	25	0.35	7	33	3
10. Synthetics 40°C	4 kg synthetics	800	23	0.35	5	40	3
11. Wool/hand 30°C	3 kg wool	800	30	0.35	0	60	3
12. Rinse programme	4 kg cotton	Max.	15	0.10	0	20	1
13. MOP wash 90°C	8 kg cotton	Max.	60	1.25	18	37	2
14. MOP wash 60°C	8 kg cotton	Max.	40	0.35	18	32	2
15. Micro fibre wash 60°C	8 kg cotton	Max.	50	0.30	18	37	3
16. Micro fibre wash 40°C	8 kg cotton	Max.	50	0.30	14	41	3
17. Disinfection 40°C	8 kg cotton	Max.	75	0.70	7	68	3
18. Disinfection 60°C	8 kg cotton	Max.	85	1.50	7	68	3
19. Disinfection 90°C	8 kg cotton	Max.	105	2.65	7	78	3
20. Programme A	Custom						
21. Programme B	Custom						
22. Programme C	Custom						





*Programme tested in accordance with EN 60456/A11/A12/.

Programme descriptions

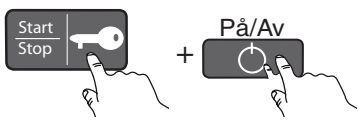
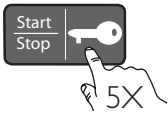
Programme designation	Description
1. Normal wash 60°C	Programme for normally to heavily soiled laundry, whites and colours. Follow the washing instructions for each garment. 60°C is a good temperature for garments worn next to the skin. This programme has five rinses.
2. Normal wash 40°C	Programme for normally to heavily soiled laundry, whites and colours. Follow the washing instructions for each garment. This programme has five rinses.
3. Heavy wash 90°C	Programme for heavily soiled laundry, with dirt that needs to be fully dissolved before the main wash. A pre-wash is used to do this.
4. Heavy wash 60°C	Programme for heavily soiled laundry, with dirt that needs to be fully dissolved before the main wash. A pre-wash is used to do this.
5. White wash 90°C	Programme for normally to heavily soiled laundry. Follow the washing instructions for each garment. 90°C is a good temperature for white and light-coloured cotton, such as bed linen.
6. White/Colour wash 60°C	Programme for normally soiled laundry, whites and colours. Follow the washing instructions for each garment. 60°C is a good temperature for garments worn next to the skin.
7. White/Colour wash 40°C	Programme for normally soiled laundry, whites and colours. Follow the washing instructions for each garment.
8. Super quick wash 60°C	Fast programme for laundry that just needs freshening up. Follow the washing instructions for each garment. Garments worn next to the skin ought to be washed at 60°C.
9. Super quick wash 40°C	Fast programme for laundry that just needs freshening up. Follow the washing instructions for each garment.
10. Synthetics 40°C	Programme for synthetics, delicate blended materials and permanent press cotton. Suitable for shirts and blouses. Follow the washing instructions for each garment. Many synthetics will come clean at 40°C.
11. Wool/hand 30°C	A gentle laundry programme for wool, silk and garments that should be washed by hand. This programme has a short spin.
12. Rinse programme	This programme performs one cold rinse cycle + spin. Suitable for laundry that just needs to be dampened.
13. MOP wash 60°C	Programme suitable for different types of mop. The programme has two rinses using much water.
14. MOP wash 90°C	Programme suitable for different types of mop. The programme has two rinses using much water.
15. Micro fibre wash 60°C	Programme for laundry made of micro fibres, such as micro-fibre cloths. The programme has three rinses with much water in the first rinse.
16. Micro fibre wash 40°C	Programme for laundry made of micro fibres, such as micro-fibre cloths. The programme has three rinses with much water in the first rinse.
17. Disinfection 40°C	Programme where the temperature reached during the main wash is maintained for 20 minutes. Disinfection at this temperature requires special detergent.
18. Disinfection 60°C	Programme where the temperature reached during the main wash is maintained for 20 minutes. Disinfection at this temperature requires special detergent.
19. Disinfection 90°C	Programme where the temperature reached during the main wash is maintained for 10 minutes. This temperature is sufficient for disinfection without special detergent.
20. Programme 20	Custom
21. Programme 21	Custom
22. Programme 22	Custom

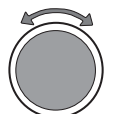





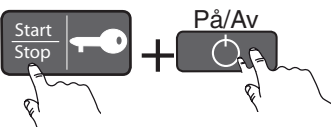
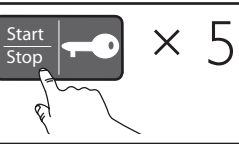

Settings

Opening the settings menu	
	<p>Is the machine on? First turn off the power at the main power switch (S1). Press and hold the Key button (S5) while simultaneously pressing the main power switch (S1).</p>
	<p>Press the Key button (S5) 5 times within 10 seconds. The settings menu now opens.</p>

Choosing a setting (an example)	
1	 <p>Turn the programme selector (J1) to cycle through the settings menu options.</p>
2	 <p>Press the Key button (S5) to select an item in the settings menu.</p>
3	 <p>Turn the programme selector (J1) to cycle through the different options for that setting.</p>
4	 <p>Press the Key button (S5) to select one of the settings.</p>
5	 <p>Press the Start/Stop button (S4) to save the settings and return to the programme menu.</p>

Service menu content		Comments
Language	US English	Note: The language used under "Special" in the service menu is not changed (English only).
	English	
	Svenska	
	Dansk	
	Norsk	
	Suomi	
	Français	
	Deutsch	
	Italiano	
	Espanol	
	Русский	
Nederlands		
Child-safe	Child-safe Off	You can temporarily disable Child-safe start by pressing the Start/Stop button and the Key button simultaneously.
	Child-safe On	
Door opening	Door opening Off	
	Door opening On	
°C/°F	°C	
	°F	

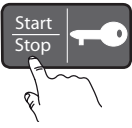
Service menu

Opening the service menu		
	<p>If the machine is on: First turn off the power at the main power switch (S1). Press and hold the Start/Stop button (S4) while simultaneously pressing the main power switch (S1).</p>	
	<p>Press the Start/Stop button (S4) 5 times within 5 seconds. The service menu now opens.</p>	
Navigating the service menu		
1		<p>Turn the programme selector (J1) to cycle through the different service menu options.</p> <ul style="list-style-type: none"> - 1 Service - 2 Settings - 3 Special
2		<p>Press the Key button (S5) to select an option in the service menu.</p>
3		<p>Turn the programme selector (J1) to cycle through the different settings.</p>
4		<p>Press the Key button (S5) to select a setting.</p>
5		<p>Turn the programme selector (J1) to select one of the options.</p>
6		<p>Press the Key button (S5) to confirm/save or go back one step.</p>
7 or	 	<p>Press the Start/Stop button (S4) to return to the programme menu or use the programme selector to make additional choices.</p> <p>NB:</p> <p>The different options in the service menu vary in terms of the number of alternative selections and settings.</p>

Service menu content

1 Service	11 Info	SP: XXXX	Date the software was programmed (Year_Week)	
		CM: XXXX	Date of manufacture of the control unit (Year_Week)	
		SW:	Software version	
		SW:	Software version	
		NC:	Number of cycles/programmes run	
		NC 1:	Number of cycles for Programme 1	
		NC 2:	Number of cycles for Programme 2	
		NC 3:	Number of cycles for Programme 3	
		NC 4:	Number of cycles for Programme 4	
		NC 5:	Number of cycles for Programme 5	
		NC 6:	Number of cycles for Programme 6	
		NC 7:	Number of cycles for Programme 7	
		NC 8:	Number of cycles for Programme 8	
		NC 9:	Number of cycles for Programme 9	
	NC 10:	Number of cycles for Programme 10		
	12 Fault scenarios	Fault 1	Shows current fault. The display shows Fault name_Programme number_Number of cycles_Index number. Example: Thermistor fault_Pr5_9_(1) Error messages are erased from the system during a total reset.	
		Fault 2		
		Fault 3		
	13 Diagnostics	Test		
		Test valve 1	Inlet valve 1 is open.	
		Test valve 2	Inlet valve 2 is open.	
		Test valve SM	Inlet valve 1 and 2 are open.	
		Test valve 3	Inlet valve 3 is open.	
		Test heater	Heater on up to max. 60°C.	
		Test motor	The motor normally runs at 49 rpm.	
		Test drain	The drainage pump runs.	
		Test spin	The machine runs a spin sequence, the drainage pump runs.	
Test door	The door lock is activated and the door opens. Returns to the programme menu.			
14 Total reset		The machine is restored to its factory settings. Returns to the programme menu after Total reset.		
15 ABC reset		The custom programmes (Pr20-Pr22) are reset. Returns to the programme menu after ABC reset.		
Return	Press the Key button (S5) to return to 1 Service.			
2 Settings	21 Water inlet	Cold		
		Hot		
	22 Max RPM	400 rpm	This function only works for programmes Pr1-Pr19.	
		600 rpm		
		800 rpm		
		1000 rpm		
		1200 rpm		
		1300 rpm		
		1400 rpm		
		1500 rpm		
		1600 rpm		
	23 Drain	Pump		
		Valve		

Service menu content (cont.)

	24 Show temp	Temp Off	Only applies to the disinfection programmes (Pr17-Pr19)	
		Temp On		
	25 Change temp	Pr1-Pr19	This can be changed in steps of 1°C between -10°C to +10°C. You cannot set a total temperature that exceeds +92°C.	
	26 Programs	Pr1-Pr19	<p>Select "On" or "Off"</p> <p>Programmes can be activated/deactivated. A deactivated programme is not shown on the display.</p> <p>A maximum of 10 programmes can be shown on the display in programme mode. If more than 10 programmes are activated, then only the first ten activated programmes are shown on the display.</p> <p>If all the programmes have been deactivated, the display only shows "Pr1".</p> <p>If the machine is Swan-labelled, "Pr1" and "Pr2" are always activated/On.</p>	
	27 Spin time	0-300 sec	<ul style="list-style-type: none"> Extend or shorten the spin time: 0-300 sec. If "0 sec" is selected, the pre-programmed spin time is used. If a time in the interval "1 sec" to "300 sec" is selected, this time is added to the pre-programmed spin time. This function only works for programmes Pr13 and Pr14. 	
	28 Coin	Coin Off	See the wiring diagram for the correct connection and functionality of a slot meter.	
		Coin On		
29 Reset	Only production reset	Used only in production		
Return	Press the Key button (S5) to return to 2 Settings.			
3 Special	Pr 20	34 Pre wash	341 Number of	0/1/2/3
			342 Water level	Normal water level/High water level
			343 Time	1/2/3/4/...../15
			344 Heat temp	No heat/25°C/26°C/...../60°C
			Return	
		35 Main wash	351 Temperature	30°C/31°C/...../92°C
			352 Water level	Normal water level/High water level
			353 Reheat temp	28°C/29°C/...../92°C
			354 Reheat time	0min/1min/...../60°C
			355 Work time	0min/1min/...../60min
	Return			
	36 Rinses	1 Rinse/2 Rinse/...../7 Rinses		
	37 Extra spin	On/off		
	38 Spin speed	400/600/800/1000/1200/1300/1400/1500/1600 RPM		
	39 Spin time	0-300 sec		
	Return	Press the Key button to return to the previous menu level.		
	Pr 21	See above		
Pr 22	See above			
Return	Press the Key button (S5) to return to 3 Special.			

Notes for custom programmes

Save these notes for future reference!



Make a note of the settings you make when creating custom programmes (Pr20, 21, 22).

Save this note close to the machine







			Notes
Pr 20	34 Pre wash	341 Number of	
		342 Water level	
		343 Time	
		344 Heat temp	
	35 Main wash	351 Temperature	
		352 Water level	
		353 Reheat temp	
		354 Reheat time	
		355 Work time	
	36 Rinses		
	37 Extra spin		
	38 Spin speed		
39 Spin time			
Pr 21	34 Pre wash	341 Number of	
		342 Water level	
		343 Time	
		344 Heat temp	
	35 Main wash	351 Temperature	
		352 Water level	
		353 Reheat temp	
		354 Reheat time	
		355 Work time	
	36 Rinses		
	37 Extra spin		
	38 Spin speed		
39 Spin time			
Pr 22	34 Pre wash	341 Number of	
		342 Water level	
		343 Time	
		344 Heat temp	
	35 Main wash	351 Temperature	
		352 Water level	
		353 Reheat temp	
		354 Reheat time	
		355 Work time	
	36 Rinses		
	37 Extra spin		
	38 Spin speed		
39 Spin time			

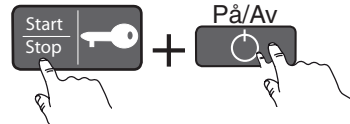
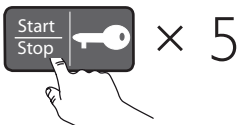

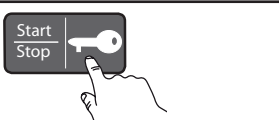

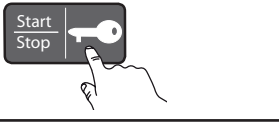

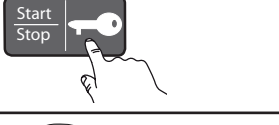

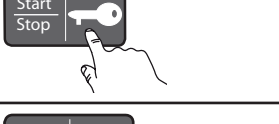

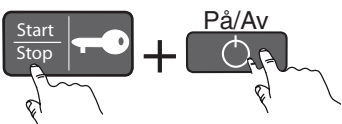
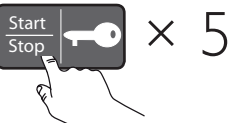

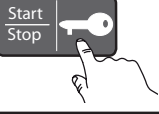

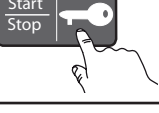
Making a custom programme

You can make three custom programmes. This is done in the service menu. In order for the new programme to be made available, one of the existing programmes must be deactivated, that is, set to "Off", and the new programme set to "On". See also the "3 Special" section of the "Service menu content" chapter.

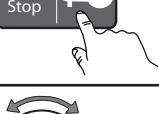
Opening the service menu	
	<p>If the machine is on: First turn off the power at the main power switch (S1). Press and hold the Start/Stop button (S4) while simultaneously pressing the main power switch (S1).</p>
	<p>Press the Start/Stop button (S4) 5 times within 5 seconds. The service menu now opens.</p>

Programming		
1		Turn the programme selector (J1) to "3 Special".
2		Press the Key button (S5) to open the "3 Special" menu.
3		Turn the programme selector (J1) to cycle through the different options: Pr20, Pr21, Pr22 and Return.
4		Press the Key button (S5) to open one of the options, Pr20, Pr21 or Pr22. Now you can create your programme by selecting from the various options and settings.
5		Turn the programme selector (J1) to cycle through the different menus: -34 Pre wash -35 Main wash -36 Rinses -37 Extra spin -38 Spin speed -39 Spin time Return
6		Press the Key button to open one of the menus.
7		Turn the programme selector (J1) to cycle through the different menu options.
8		Press the Key button to save the setting and return to the previous menu level. Repeat steps 5 to 8 to programme the remaining settings.
9		Once you have finished creating the programme, press the Start/Stop button (S4) to return to the programme menu.

Activate the new programme		
1		If the machine is on: First turn off the power at the main power switch (S1). Press and hold the Start/Stop button (S4) while simultaneously pressing the main power switch (S1).
2		Press the Start/Stop button (S4) 5 times within 5 seconds. The service menu now opens.
3		Turn the programme selector (J1) to "2 Settings".
4		Press the Key button (S5) to open the "2 Settings" menu.
5		Turn the programme selector (J1) to "26 Programs".
6		Press the Key button (S5) to open the "26 Programs" menu.
7		Turn the programme selector (J1) to select the programme you want to deactivate.
8		Press the Key button to open the menu.
9		Turn the programme selector to "Off" to deactivate the programme.
10		Press the Key button (S5) to confirm/save.
11		Activate your new programme by turning the programme selector to the programme you want to activate.
12		Press the Key button to open the menu.
13		Turn the programme selector to "On" to activate the programme.
14		Press the Key button to confirm/save.

Fault indicators

Error message	Cause	Action
Over flow fault	Too much water in the machine.	Service action: Check the machine's level system, inlet valve and drainage pump. Check for any leaks.
	The drainage pump is running but the machine is empty.	
Water outlet fault	<ul style="list-style-type: none"> • The drainage pump has been running for 3 minutes. Water remains in the machine. • The wash cycle is stopped and the programme is reset. 	<ol style="list-style-type: none"> 1. Check that nothing is stuck in the drainage hose outlet. 2. Check that the drainage pump is not blocked by foreign objects. 3. Check that there are no kinks in the drainage hose. Service action: <ol style="list-style-type: none"> 1. If the pump only runs for a short while (approximately 20 seconds), this indicates a fault in the level system. Check the level sensor and hoses. 2. Check the wiring and voltage to the pump. If necessary, replace the pump and/or control unit. 3. After taking corrective action, run the Drain programme or press the Key (door opening) button to empty the machine.
Water inlet fault	If the correct water level is not achieved within five minutes the wash cycle will be stopped.	<ol style="list-style-type: none"> 1. Check that the tap on the water pipe is open. Service action: <ol style="list-style-type: none"> 1. Check that the filter in the machine's water intake is not blocked. 2. Check the inlet valve. If necessary, replace the valve. 3. Check the voltage to the inlet valve. If there is no voltage, this could be due to a fault in the level system, wiring or control unit.
Security fault	The door is open	Close the door
Thermistor fault	<ol style="list-style-type: none"> 1. Thermistor circuit open 2. Thermistor malfunction 3. The measurement value for the thermistor is $<300 \Omega$ ($>120^{\circ}\text{C}$) 	Service action: Check the thermistor. Replace if necessary.
Temperature fault	<p>The temperature has increased $< 5^{\circ}\text{C}$ in ten minutes</p> <p>The wash cycle should continue to the next step of the programme.</p>	Service action: Check the thermistor, heater, wiring and level system.
Wash motor fault	No signal from the tacho or MCU.	Service action: Check the output signal from the MCU and the wiring between the motor and the MCU.
Pressure fault	Indicated if the level drops to zero within 30 seconds of the first rinse.	Service action: Check for leaks.

Components and measurement values

Item number	Component	Measurement value	Comment
80 658 33	CIM motor	Resistances: Pins 1-3 stator 3.7 Ω Pins 1-2 stator 3.6 Ω Pins 2-3 rotor 3.6 Ω Pins 4-5 tachometer 178 Ω	
80 617 03 80 617 04	Heating element 2000 W Heating element 1000 W		
80 761 02	Thermistor	6.1–3.8 k Ω (at room temperature 20–30°C)	The thermistor for measuring temperature is located between the motor cradle and the drum. The thermistor measures and controls the water temperature, which can vary from 0 to 92°C. The heater is disconnected if the thermistor is short-circuited or disconnected from the programme control card.
88 012 63	Drainage pump 50 Hz	144 Ω	The drainage pump is combined with an integrated fine filter trap, which can be cleaned by the user. If the drainage pump has run for 3 minutes during draining, the programme stops, resets and a fault code is indicated on the display. The pump has a capacity of 20 litres/minute.
88 012 64	Drainage pump 60 Hz	76 Ω	
80 782 21	Level switch		Electromechanical level switch with two levels (see wiring diagram). Used to indicate levels for door opening, heat and overflow.
80 762 02	EMC filter 50/60 Hz	680 Ω	The filter eliminates interference to and from the machine.
80 793 24	Inlet valve	3.7 k Ω \pm 0.5 k Ω	Two-way inlet valve, 8 litres/minute
80 798 73	Door lock	122 Ω	The door lock is electromechanical and equipped with a magnet.
80 833 15	One-way inlet valve		
80 818 07	Motor control		
80 806 28	Control unit		
80 833 43	Communication unit		
80 083 65	Outlet valve		

Thermistor measurement values

Temp, °C	Resistance, ohm
0	15806
10	9634
20	6046
25	4841
30	3900
40	2579
50	1744
60	1204
70	848
80	609
85	519

Technical data

Height:	850 mm
Width:	595 mm
Depth:	585 mm
Weight:	73 kg
Cylinder volume:	60 l
Max. load capacity	8 kg/6 kg
Spin speed:	800-1600
Connection:	1-phase 16 A, 3-phase 10 A
Heater output:	2000 W/3000 W
Water pressure/inlet valve:	0.1–1 MPa, 1–10 kp/cm ² , 10–100 N/cm ² 8 l/min
Wash drum and liquid compartment:	Stainless steel
Outer panels:	Powder-coated and hot-galvanised sheet steel or stainless steel
Installation:	Stationary on four adjustable, rubber-clad feet
Water connection:	1.5 m PEX tubing, 3/4"–3/4" or 3/4"–1/2"
Drainage:	1.7 m polypropylene tubing
Protection class:	IP X4
Water consumption (tested normal programme)	59 litres, 3 rinses (5 kg/6 kg) <72 litres, 5 rinses (6 kg) <69 litres, 5 rinses (5 kg)
Water consumption (tested normal programme)	1.02 kWh (6 kg) 0.95 kWh (5 kg)
Electricity consumption, Standby:	
- Machine turned off	<0.3 W
- Delayed start	<6.0 W
- Programme ended	<3.0 W

Tools

Torx: T25, T20, T10
Ring spanner: 11/16", 16 mm, 13 mm, 10 mm
Socket screwdriver 10 mm
Extended socket 24 mm + ratchet handle
Allen key 5 mm + small ratchet handle
Plastic hammer
Phillips screwdriver
Wire cutter

Wiring diagram

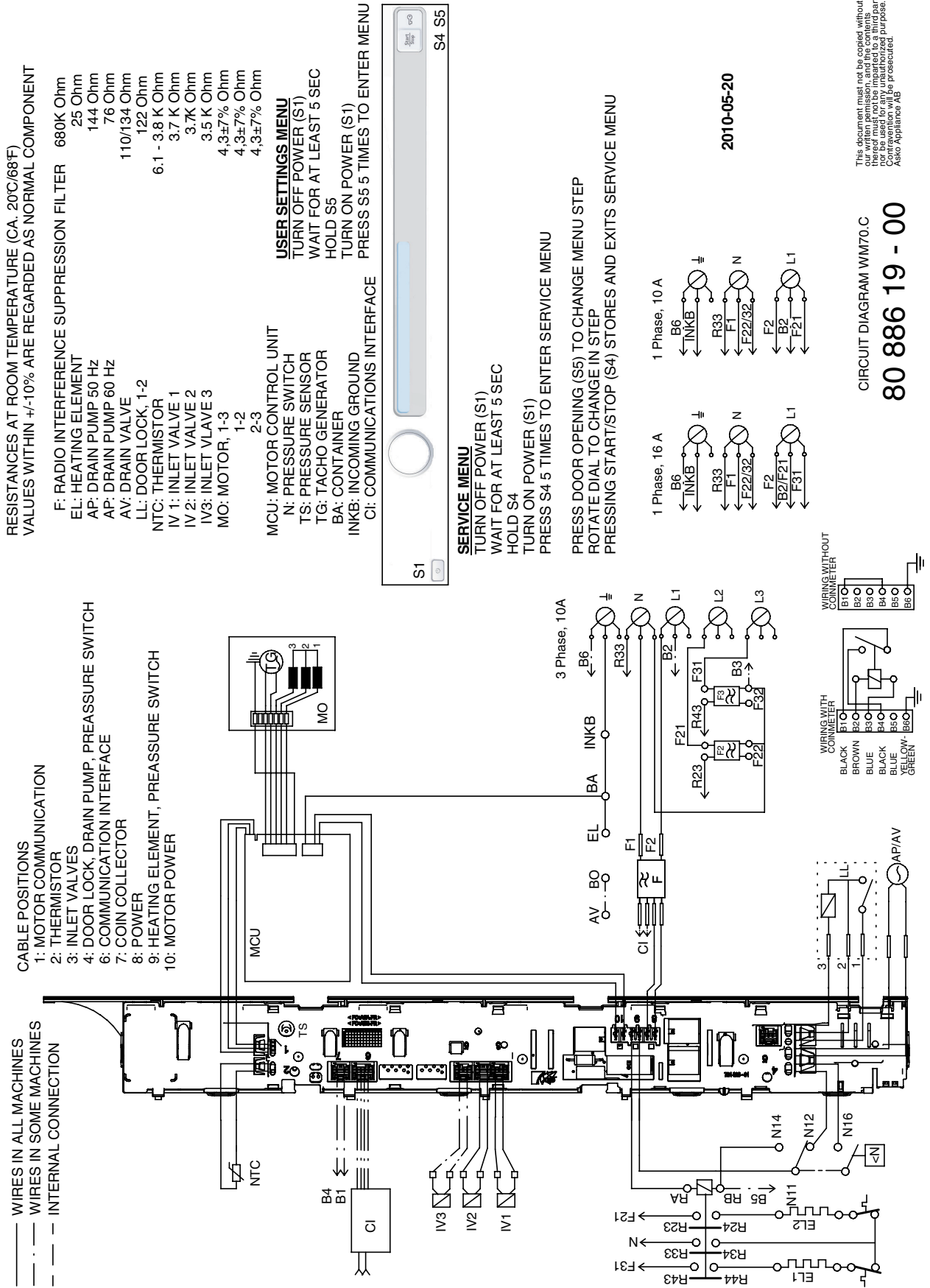

This document must not be copied without our written permission, and the contents hereof must not be imparted to a third party without the prior written consent of Asko Appliance AB

CIRCUIT DIAGRAM WM70.C

80 886 19 - 00

RESISTANCES AT ROOM TEMPERATURE (CA. 20°C/68°F)
VALUES WITHIN +/-10% ARE REGARDED AS NORMAL COMPONENT

- F: RADIO INTERFERENCE SUPPRESSION FILTER 680K Ohm
- EL 1: HEATING ELEMENT 25 Ohm
- EL 2: HEATING ELEMENT 52 Ohm
- AP: PUMP 60 Hz 76 Ohm
- RP: RECIRCULATION PUMP 60 Hz 76 Ohm
- AV: DRAIN VALVE 110/134 Ohm
- LL: DOOR LOCK, 1-2 122 Ohm
- NTC: THERMISTOR 6.1 - 3.8 K Ohm
- IV 1: INLET VALVE 1 3.7 K Ohm
- IV 2: INLET VALVE 2 3.7 K Ohm
- MO: MOTOR, 1-3 4.3±7% Ohm
- 1-2 4.3±7% Ohm
- 2-3 4.3±7% Ohm

CABLE POSITIONS
1: MOTOR COMMUNICATION
2: THERMISTOR
3: INLET VALVES
4: DOOR LOCK, DRAIN PUMP, PREASSURE SWITCH
6: COMMUNICATION INTERFACE
7: COIN COLLECTOR
8: POWER
9: HEATING ELEMENT, PREASSURE SWITCH
10: MOTOR POWER

WIRES IN ALL MACHINES
WIRES IN SOME MACHINES
INTERNAL CONNECTION

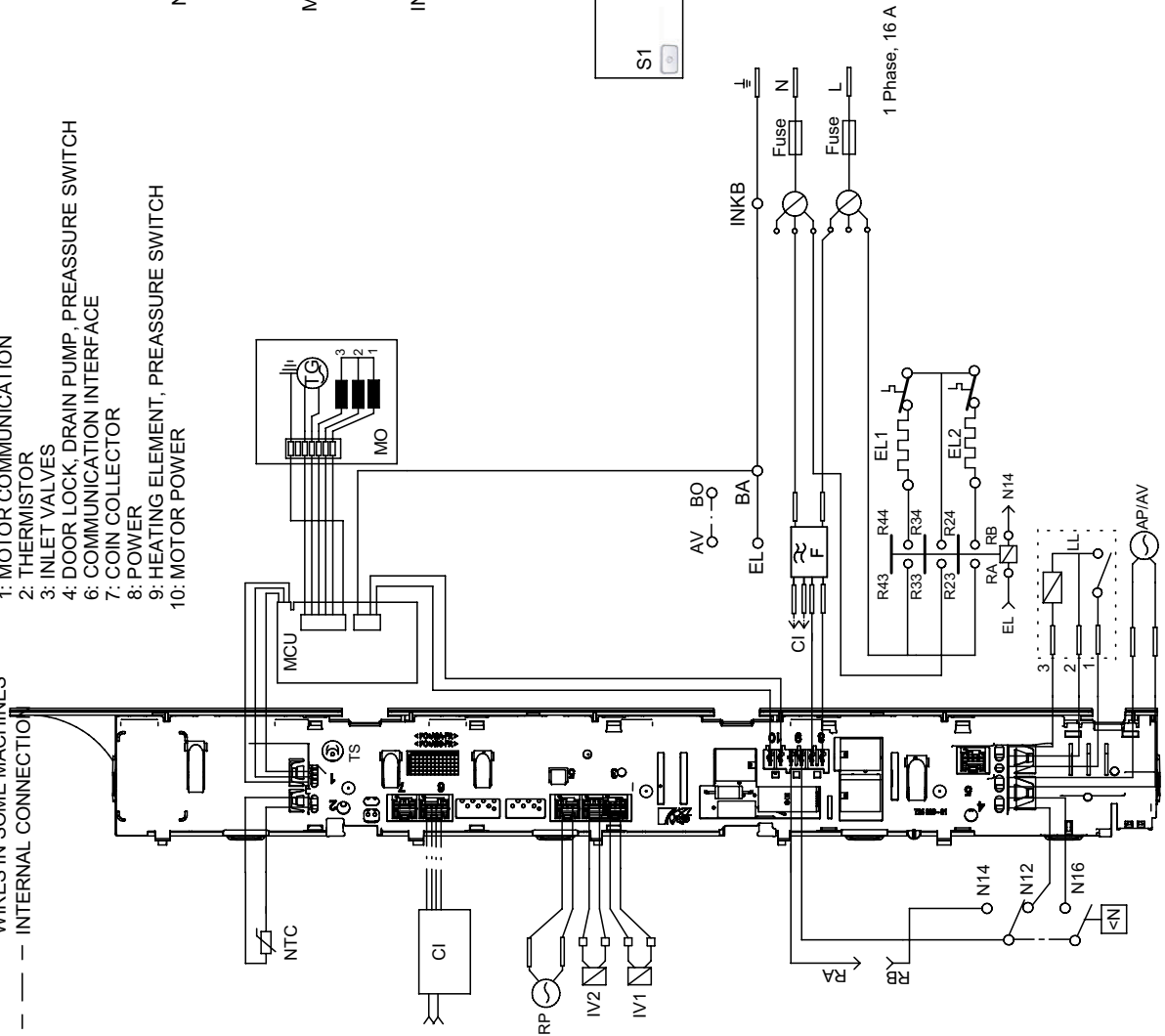

USER SETTINGS MENU

- TURN OFF POWER (S1)
- WAIT FOR AT LEAST 5 SEC
- HOLD S5
- TURN ON POWER (S1)
- PRESS S5 5 TIMES TO ENTER MENU

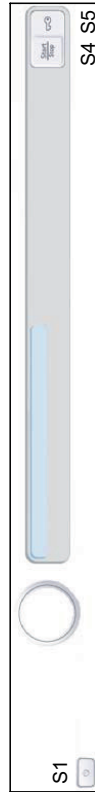

SERVICE MENU

- TURN OFF POWER (S1)
- WAIT FOR AT LEAST 5 SEC
- HOLD S4
- TURN ON POWER (S1)
- PRESS S4 5 TIMES TO ENTER SERVICE MENU
- PRESS DOOR OPENING (S5) TO CHANGE MENU STEP
- ROTATE DIAL TO CHANGE IN STEP
- PRESSING START/STOP (S4) STORES AND EXITS SERVICE MENU

2010-05-20

CIRCUIT DIAGRAM WM70.C WC US/CA

80 893 65 - 00

This document must not be copied without our written permission, and the contents hereof must not be imparted to a third party without the prior written permission of Contravenion will be prosecuted. Askto Appliance AB

RESISTANCES AT ROOM TEMPERATURE (CA. 20°C/68°F)
VALUES WITHIN +/-10% ARE REGARDED AS NORMAL COMPONENT

- F: RADIO INTERFERENCE SUPPRESSION FILTER 680K Ohm
- EL1: HEATING ELEMENT 25 Ohm
- EL2: HEATING ELEMENT 52 Ohm
- AP: DRAIN PUMP 60 Hz 76 Ohm
- AV: DRAIN VALVE 110 Ohm
- LL: DOOR LOCK, 1-2 122 Ohm
- NTC: THERMISTOR 6.1 - 3.8 K Ohm
- IV 1: INLET VALVE 1 3.7 K Ohm
- IV 2: INLET VALVE 2 3.7 K Ohm
- IV3: INLET VALVE 3 3.5 K Ohm
- MC: MOTOR, 1-3 4,3±7% Ohm
- 1-2 4,3±7% Ohm
- 2-3 4,3±7% Ohm

USER SETTINGS MENU

- N: MOTOR CONTROL UNIT
- TS: PRESSURE SENSOR
- TG: TACHO GENERATOR
- BA: CONTAINER
- INKB: INCOMING GROUND
- CI: COMMUNICATIONS INTERFACE

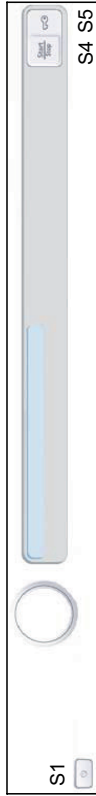

SERVICE MENU

- TURN OFF POWER (S1)
- WAIT FOR AT LEAST 5 SEC
- HOLD S4
- TURN ON POWER (S1)
- PRESS S4 5 TIMES TO ENTER SERVICE MENU
- PRESS DOOR OPENING (S5) TO CHANGE MENU STEP
- ROTATE DIAL TO CHANGE IN STEP
- PRESSING START/STOP (S4) STORES AND EXITS SERVICE MENU

2010-05-20

This document must not be copied without
thereof must not be imparted to a third party
or be used for any unauthorized purpose.
Asiko Appliances AB

CIRCUIT DIAGRAM WM70.C US/CA

80 896 25 - 00

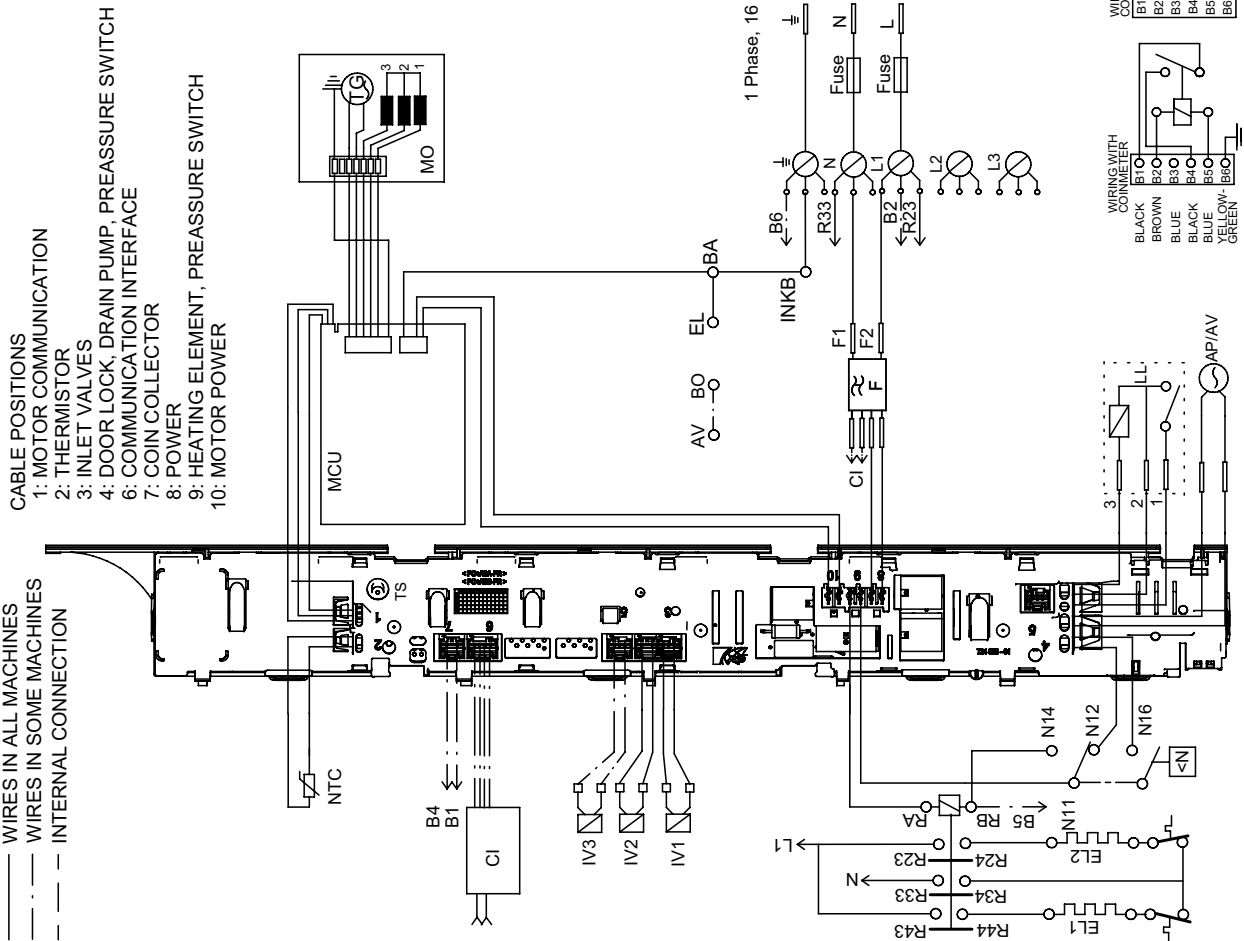

CABLE POSITIONS

- 1: MOTOR COMMUNICATION
- 2: THERMISTOR
- 3: INLET VALVES
- 4: DOOR LOCK, DRAIN PUMP, PREASSURE SWITCH
- 6: COMMUNICATION INTERFACE
- 7: COIN COLLECTOR
- 8: POWER
- 9: HEATING ELEMENT, PREASSURE SWITCH
- 10: MOTOR POWER

— WIRES IN ALL MACHINES
- - - WIRES IN SOME MACHINES
- - - INTERNAL CONNECTION

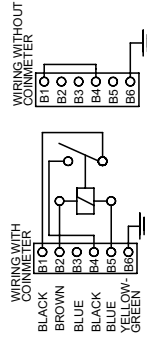

RESISTANCES AT ROOM TEMPERATURE (CA. 20°C/68°F)
VALUES WITHIN +/-10% ARE REGARDED AS NORMAL COMPONENT

- F: RADIO INTERFERENCE SUPPRESSION FILTER 680K Ohm
- EL 1: HEATING ELEMENT 25 Ohm
- EL2: HEATING ELEMENT 52 Ohm
- AP: PUMP 60 Hz 76 Ohm
- RP: RECIRCULATION PUMP 60 Hz 76 Ohm
- AV: DRAIN VALVE 110/134 Ohm
- LL: DOOR LOCK, 1-2 122 Ohm
- NTC: THERMISTOR 6.1 - 3.8 K Ohm
- IV 1: INLET VALVE 1 3.7 K Ohm
- IV 2: INLET VALVE 2 3.7 K Ohm
- MO: MOTOR, 1-3 4,3±7% Ohm
- 1-2 4,3±7% Ohm
- 2-3 4,3±7% Ohm

- MCU: MOTOR CONTROL UNIT
- N: PRESSURE SWITCH
- TS: PRESSURE SENSOR
- TG: TACHO GENERATOR
- BA: CONTAINER
- INKB: INCOMING GROUND
- CI: COMMUNICATIONS INTERFACE

USER SETTINGS MENU

- TURN OFF POWER (S1)
- WAIT FOR AT LEAST 5 SEC
- HOLD S5
- TURN ON POWER (S1)
- PRESS S5 5 TIMES TO ENTER MENU

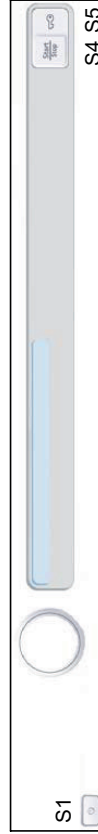

SERVICE MENU

- TURN OFF POWER (S1)
- WAIT FOR AT LEAST 5 SEC
- HOLD S4
- TURN ON POWER (S1)
- PRESS S4 5 TIMES TO ENTER SERVICE MENU
- PRESS DOOR OPENING (S5) TO CHANGE MENU STEP
- ROTATE DIAL TO CHANGE IN STEP
- PRESSING START/STOP (S4) STORES AND EXITS SERVICE MENU

- CABLE POSITIONS
- 1: MOTOR COMMUNICATION
 - 2: THERMISTOR
 - 3: INLET VALVES
 - 4: DOOR LOCK, DRAIN PUMP, PREASSURE SWITCH
 - 6: COMMUNICATION INTERFACE
 - 7: COIN COLLECTOR
 - 8: POWER
 - 9: HEATING ELEMENT, PREASSURE SWITCH
 - 10: MOTOR POWER

- WIRES IN ALL MACHINES
- - - WIRES IN SOME MACHINES
- INTERNAL CONNECTION

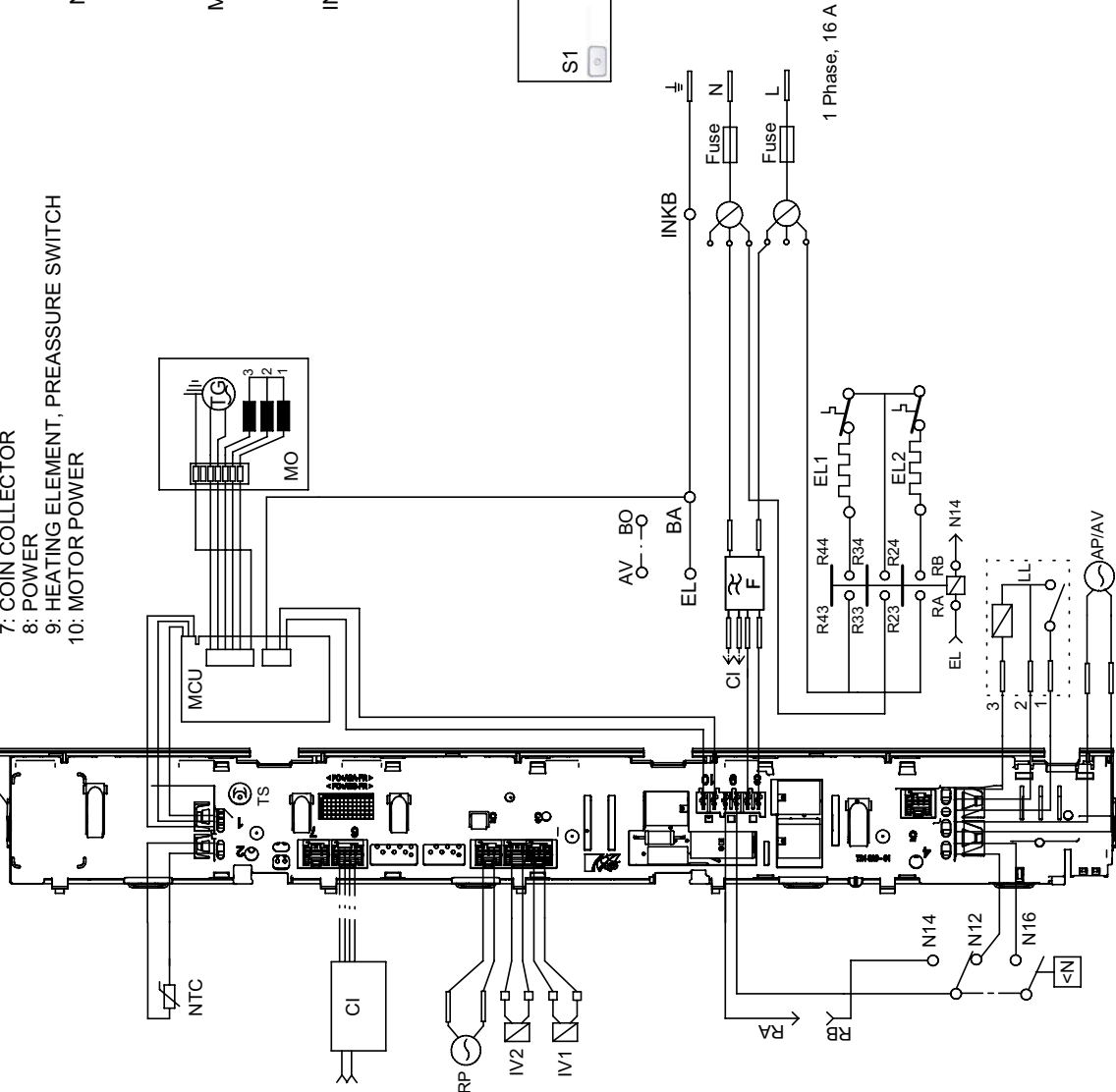

2010-05-20

CIRCUIT DIAGRAM WM70.C WC US/CA

80 893 65 - 00

This document must not be copied without
our written permission, and its contents
must not be used for any unauthorized party.
Contravention will be prosecuted.
Apro Appliance AB

— WIRES IN ALL MACHINES
 - - - WIRES IN SOME MACHINES
 --- INTERNAL CONNECTION

CABLE POSITIONS
 1: MOTOR COMMUNICATION
 2: THERMISTOR
 3: INLET VALVES
 4: DOOR LOCK, DRAIN PUMP, PREASSURE SWITCH
 6: COMMUNICATION INTERFACE
 7: COIN COLLECTOR
 8: POWER
 9: HEATING ELEMENT, PREASSURE SWITCH
 10: MOTOR POWER

RESISTANCES AT ROOM TEMPERATURE (CA. 20°C/68°F)
 VALUES WITHIN +/-10% ARE REGARDED AS NORMAL COMPONENT

- F: RADIO INTERFERENCE SUPPRESSION FILTER 680K Ohm
- EL1: HEATING ELEMENT 25 Ohm
- EL2: HEATING ELEMENT 52 Ohm
- AP: DRAIN PUMP 60 Hz 76 Ohm
- AV: DRAIN VALVE 110/134 Ohm
- LL: DOOR LOCK, 1-2 122 Ohm
- NTC: THERMISTOR 6.1 - 3.8 K Ohm
- IV 1: INLET VALVE 1 3.7 K Ohm
- IV 2: INLET VALVE 2 3.7 K Ohm
- IV3: INLET VLAVE 3 3.5 K Ohm
- MO: MOTOR, 1-3 4.3±7% Ohm
- 2-3 4.3±7% Ohm
- 4.3±7% Ohm

- MCU: MOTOR CONTROL UNIT
- N: PRESSURE SWITCH
- TS: PRESSURE SENSOR
- TG: TACHO GENERATOR
- BA: CONTAINER
- INKB: INCOMING GROUND
- T: TRANSFORMER 440/230V 50/60Hz

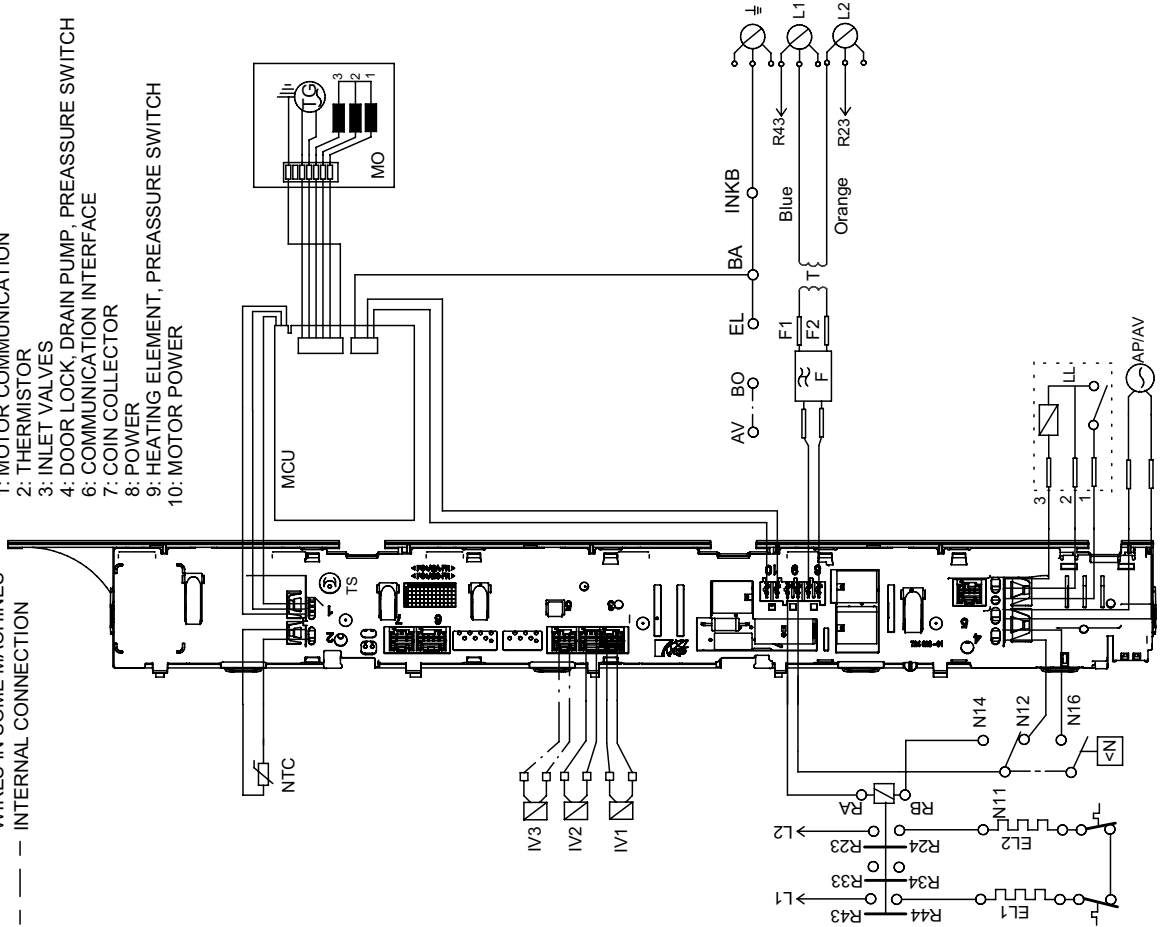

SERVICE MENU

- TURN OFF POWER (S1)
- WAIT FOR AT LEAST 5 SEC
- HOLD S4
- TURN ON POWER (S1)
- PRESS S4 5 TIMES TO ENTER SERVICE MENU
- PRESS DOOR OPENING (S5) TO CHANGE MENU STEP
- ROTATE DIAL TO CHANGE IN STEP
- PRESSING START/STOP (S4) STORES AND EXITS SERVICE MENU
- USER SETTINGS MENU**
- TURN OFF POWER (S1)
- WAIT FOR AT LEAST 5 SEC
- HOLD S5
- TURN ON POWER (S1)
- PRESS S5 5 TIMES TO ENTER MENU

2010-05-20

CIRCUIT DIAGRAM WM70.C MARINE

80 896 27 - 00

This document must not be copied without our written permission, and the contents thereof may not be used for any unauthorized purpose. Contravention will be prosecuted. Asko Appliance AB

Panel and control card replacement

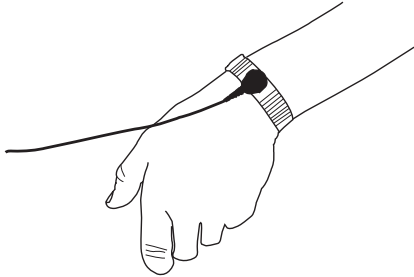
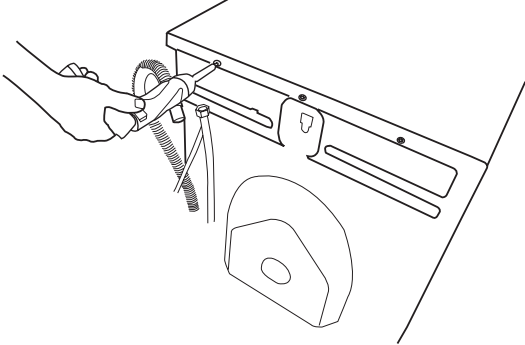
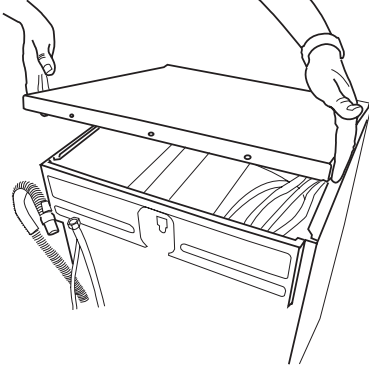
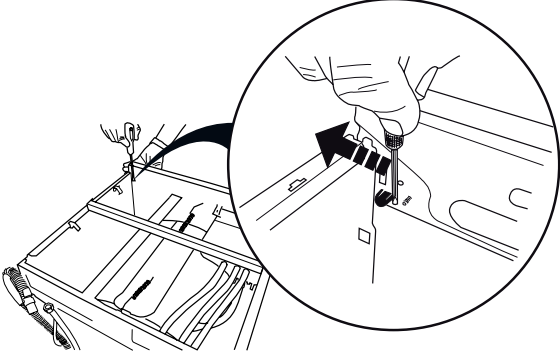
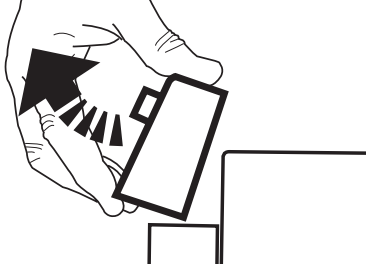
<p>1. Attach the anti-static wristband to a part of the machine that is earthed!</p> <p>NB: An anti-static wristband must be used, otherwise you risk destroying the control card.</p>	
<p>2. Undo the three screws holding the top cover in place.</p>	
<p>3. Remove the top cover:</p>	
<p>4. Use a screwdriver to carefully free the panel. As you do so, carefully angle the panel outwards.</p>	
<p>5. Remove the panel and the cables. NB: Don't forget to remove the pressure sensor tube.</p>	

Panel and control card replacement (cont.)

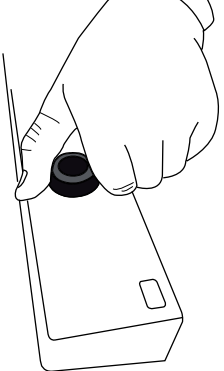
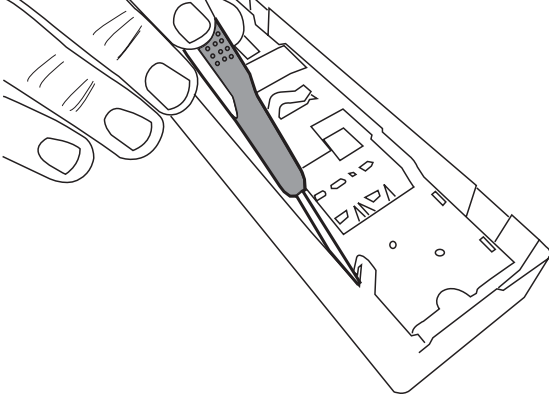
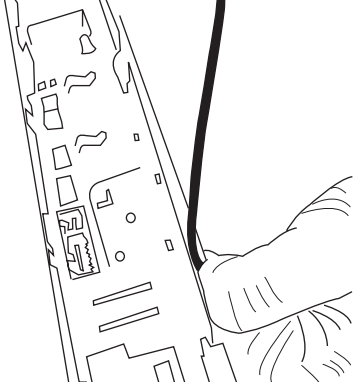
<p>6. Carefully pull the programme selector from the panel.</p>	
<p>5. Use a screwdriver to free the control card from the panel. NB: The control card must be placed in an ESD-safe bag.</p>	
<p>6. Check that the push button, lens and decorative inlay are in place. Now carefully press the new control card into place. NB: Don't forget to replace the rubber seal.</p>	

Wash agitator removal

When replacing or cleaning the wash agitators, or when removing items that have fallen through the wash drum, first you need to remove the agitators. Follow the instructions below.

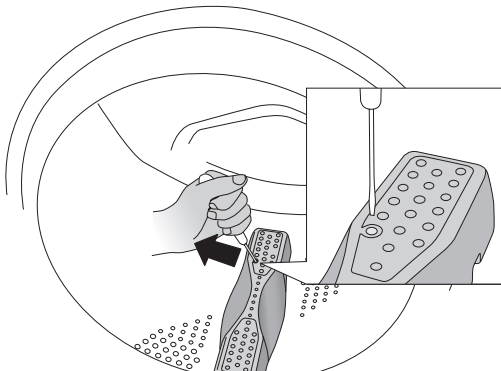
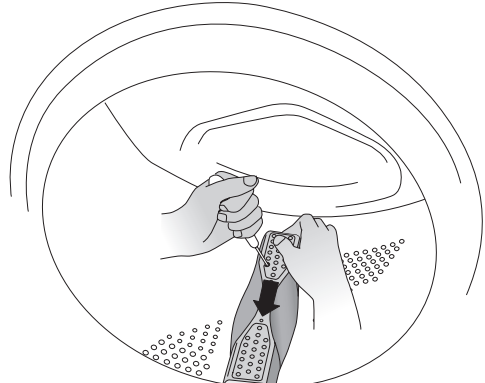
<p>1. Insert a screwdriver or the like into the hole on the agitator as illustrated and carefully pry to the left.</p>	
<p>2. Use your other hand to grasp the agitator and pull it towards you. 3. Lift the agitator. 4. Remove any foreign objects.</p>	
<p>5. Place the agitator in the mounting hole with the letter F towards you. Ensure that all the agitator fasteners are in their holes in the drum. Push it away from you until it fastens.</p>	