



WFMC/WFXD WASHER TRAINING MANUAL

BOSCH
SIEMENS

WFMC/WFXD Washer Table of Contents

- Operation..... 3
- Disassembly..... 17
- Ratings..... 34
- Service Tips..... 39
- Test Program..... 53
- Troubleshooting..... 67
- Maintenance..... 72



Operation – WFMC Fascia Panels

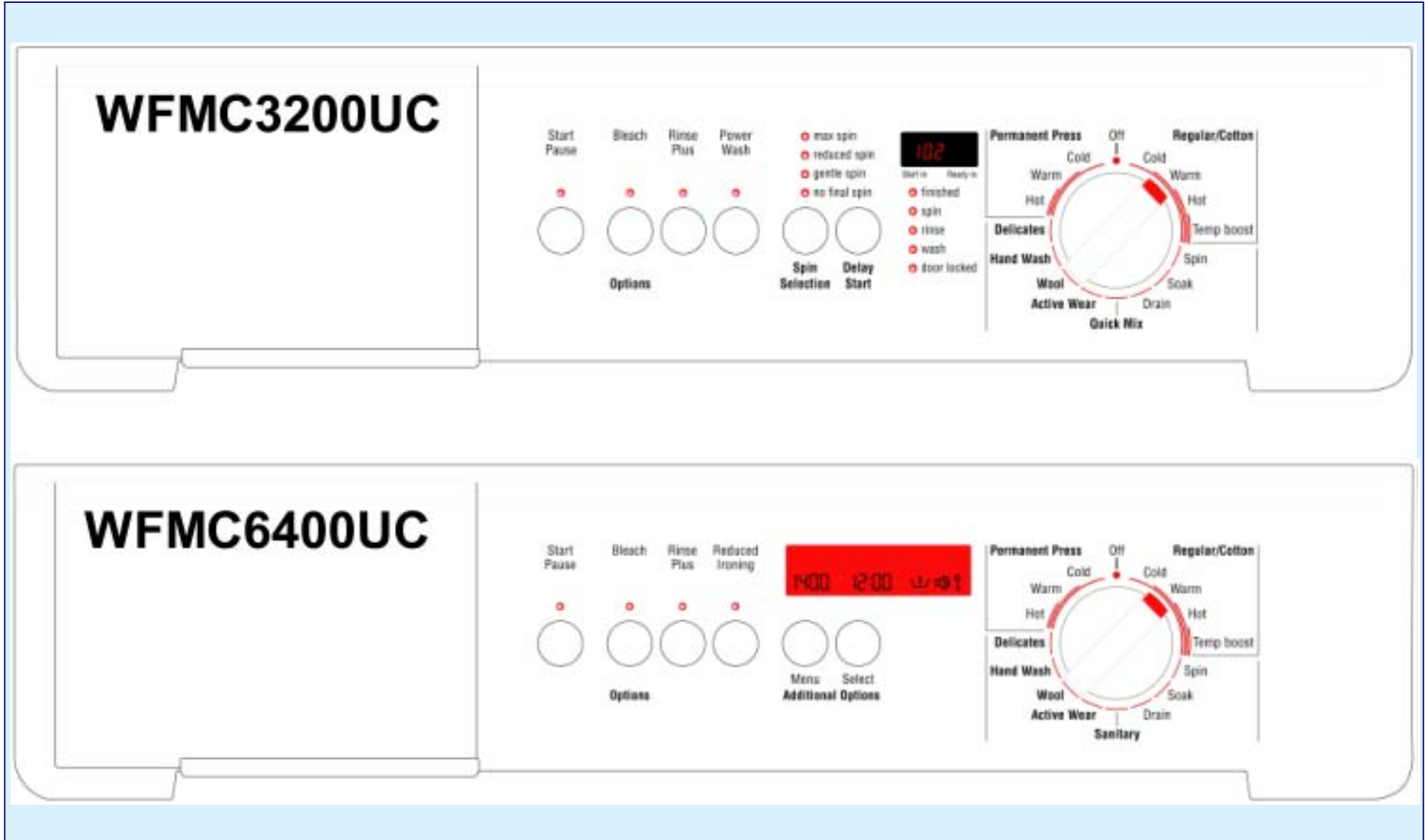

Operation – WFXD Fascia Panels

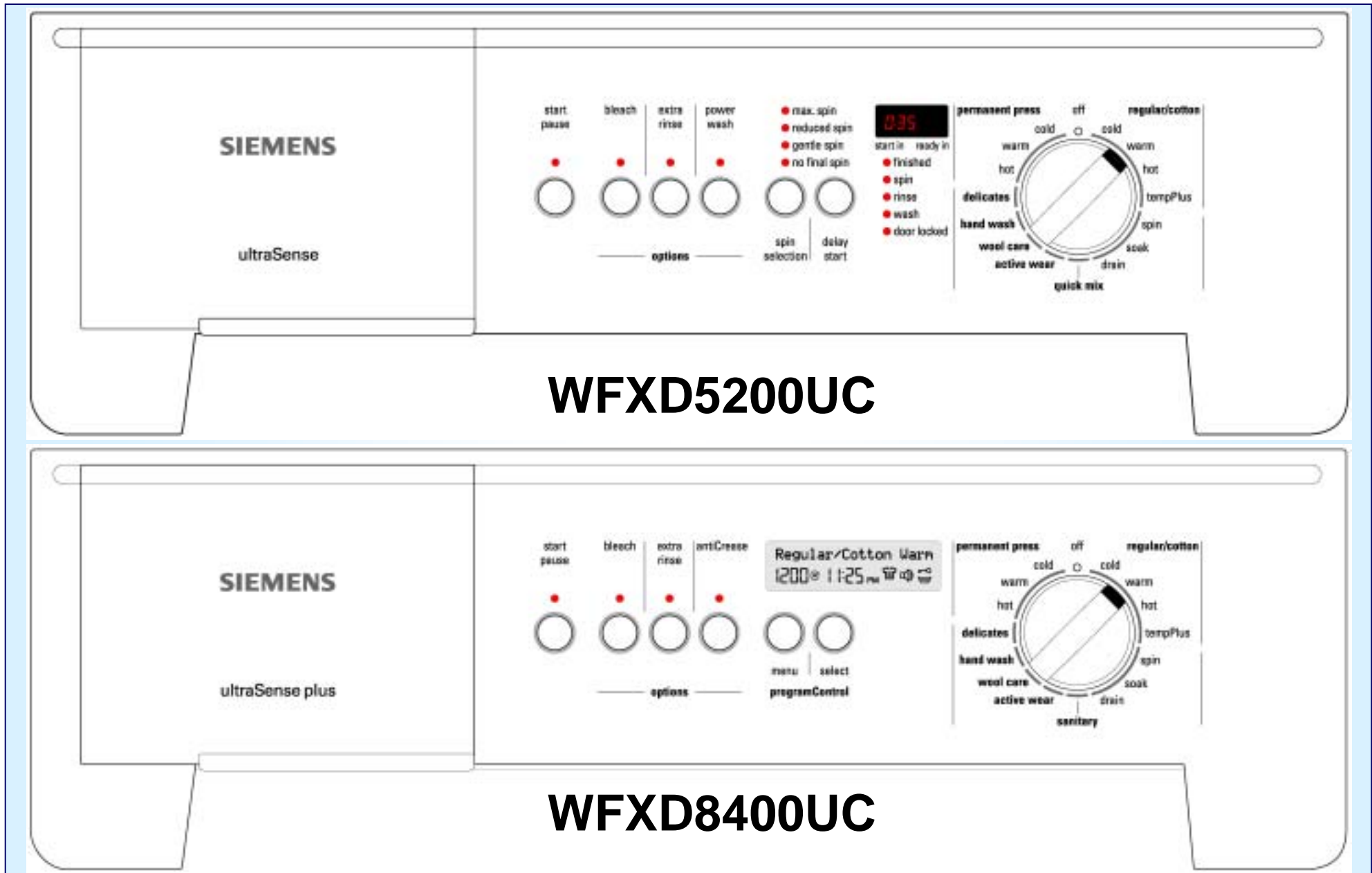

Operation – WFMC Controls

WFMC3200UC

WFMC64UC

Both have Regular/Cotton, Permanent Press, Delicates, Hand Wash, Temperature Boost, Wool, Active Wear, Rinse Plus & Bleach settings.

Special Wash Buttons

Digital Display

Cycle Selector Knob

Both have Regular/Cotton, Permanent Press, Delicates, Hand Wash, Temperature Boost, Wool, Active Wear, Rinse Plus & Bleach settings.

WFMC64UC

Operation – WFXD Controls

WFXD5200UC

Both have Regular/Cotton, Permanent Press, Delicates, Hand Wash, Temp Plus, Wool Care, Active Wear, Extra Rinse & Bleach settings.

WFXD8400UC

Special Wash Buttons

Digital Display

Cycle Selector Knob

Operation – Sensors (1)

1A. Load Sensor (WFMC32/WFXD52)

At a predefined points during the initial fill, the washer determines if it needs more water using a pressure switch. This is due to differences in the absorption of the laundry and the size of the loads.

1B. Dynamic Load Sensor (WFMC64/WFXD84)

During the entire fill the washer continually adjusts for the size of the load and determines if more water is needed using an analog pressure switch and a flow meter.

2. Digital Temperature Sensor (WFMC32/WFXD52 & WFMC64/WFXD84)

The thermostat monitors the temperature of the water and controls the length of time the heating element is on, ensuring the proper temperature for the chosen cycle.

3A. Suds Sensor (WFMC32/WFXD52)

During the beginning of the 1st rinse/spin phase, the washer determines if there are excessive suds and automatically adds 2 rinses (if necessary). This is accomplished via the pressure switch and the motor synchronization system.

3B. Continuous Suds Sensor (WFMC64/WFXD84)

Checking the pumping out phase of the main wash, the beginning of the 1st rinse/spin phase and the actual spin speed vs. the programmed spin speed, the washer determines if there are excessive suds and automatically adds up to 2 rinses (if necessary). This is accomplished via the pressure switch, analog pressure switch and the motor synchronization system.

4. Unbalanced Load Sensor (WFMC32/WFXD52 & WFMC64/WFXD84)

During the final spin cycle the washer monitors the positioning and balance of the load. If the load unbalanced, the washer stops and adjusts the load up to 15 times and reduces the spin speed to finish the cycle. This is accomplished via the motor synchronization system.

Operation – Sensors (2)

1A/1B. Load & Dynamic Load Sensors

Mechanical Pressure Switch - (WFMC32/WFXD52 & WFMC64/WFXD84) measures the water level after the first fill. If the water level is high (like for smaller loads), the pressure increases and the pressure switch does not provide more water.

Analog Pressure Switch - (WFMC64/WFXD84)

- Precise measuring of actual water level
- Accurate load detection
- Control of the pump - noise reduction
- Time reduction - no pumping when empty

BENEFITS: Continuous adjustment of wash times

Water and energy consumed varies according to load size

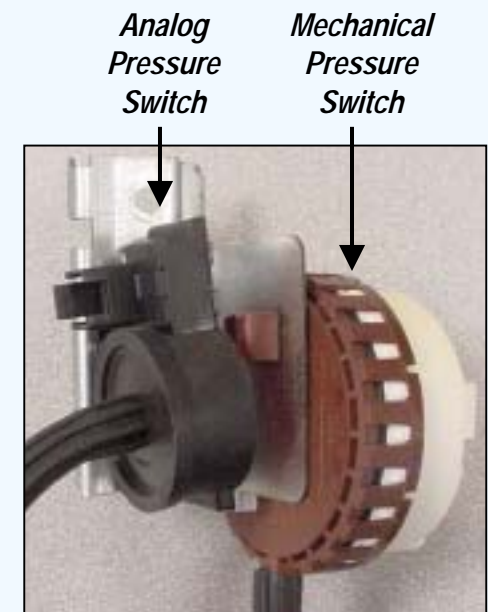

Operation – Sensors (3)

1A/1B. Flow Meter

- Exact monitoring of water inflow.
- Ensures exact control of water inlet valves so that there is always the right amount of water for wash and rinse cycles.
- Together with the pressure switch, there is a continuous adjustment of wash time, water and energy in relation to the load size.
- The flow meter works independently of water pressure.

BENEFITS: Minimizes water consumption

Exact Load Detection

Superior Cleaning Performance

- An **internal water clock** monitors water inflow via soak compartment.
- Ensures exact control of water inlet valves - always right amount of water.
- Independent from water pressure.



Operation – Sensors (4)

2. Digital Temperature Sensor

All models are equipped with an Electric Heater and Temperature Sensor (NTC) to deliver guaranteed wash temperatures.

NOTE: Compare with competition washers which only have heaters in top of the line models.



Operation – Sensors (5)

3A/3B. Suds & Continuous Suds Sensors

- WFMC64/WFXD84** ✓ Detection **during draining out after main wash**
→ immediate additional rinse & cancelling of 1st rinse spin
- WFMC64/WFXD84** ✓ Detection **during 1st rinse spin**
→ immediate interruption of spin
- WFMC32/WFXD52** → insertion of **one** or **two** additional rinses
→ reduced agitation during additional anti foam rinse
- WFMC64/WFXD84** ✓ Detection **during any other rinse spin**
→ immediate interruption of spin
→ reduced agitation in following rinse cycle
- ✓ **All subsequent rinse spin cycles are always rechecked for suds**

NOTE: Suds build-up usually occur only when way too much detergent is used with lightly soiled loads.

Operation – Sensors (6)

4. Unbalanced Load Sensor

2-step detection

- Accurate measuring of unbalance by **deviation of spin speed** and **slow down time of drum**
- **Infinite adapting** of spin speeds
- Compensates reducing of spin speeds by **prolonging spinning times**
- Will attempt up to 15 times to redistribute a load

Advantages:

- **Reduction of noise**
- **Better stability of machine**
- **Good spinning results with big unbalances**



Operation – Sensors (7)

4. Unbalanced Load Sensor

2-step detection



load distribution	unbalance	Spin speed (rpm)	spinning profile
good	small	1200 (max.)	I
uneven	medium	1000 (reduced)	II
bad	big	800 (low)	III
none	dangerous	no spinning	IV

After 4 attempts
 After 7 attempts
 After 14 attempts

Operation – Cleaning Drain Pump Trap

Unlike WFK, WFL & WFR washers, WPMC/WFXD drain pumps are maintenance-free. So, larger objects such as coins and paper clips are no longer collected in the drain pump trap. The drain pump trap is only meant to be cleared by servicers.



HINT: To remove the drain pump access cover, insert a pointed object (or tool) into the hole, push in to release the latch and rotate the cover clockwise.

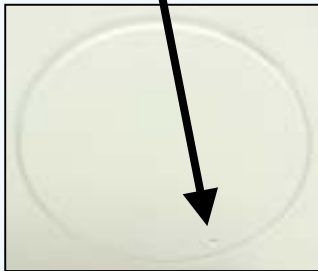

Current production pumps are beige color – earlier WPMC pumps were black.

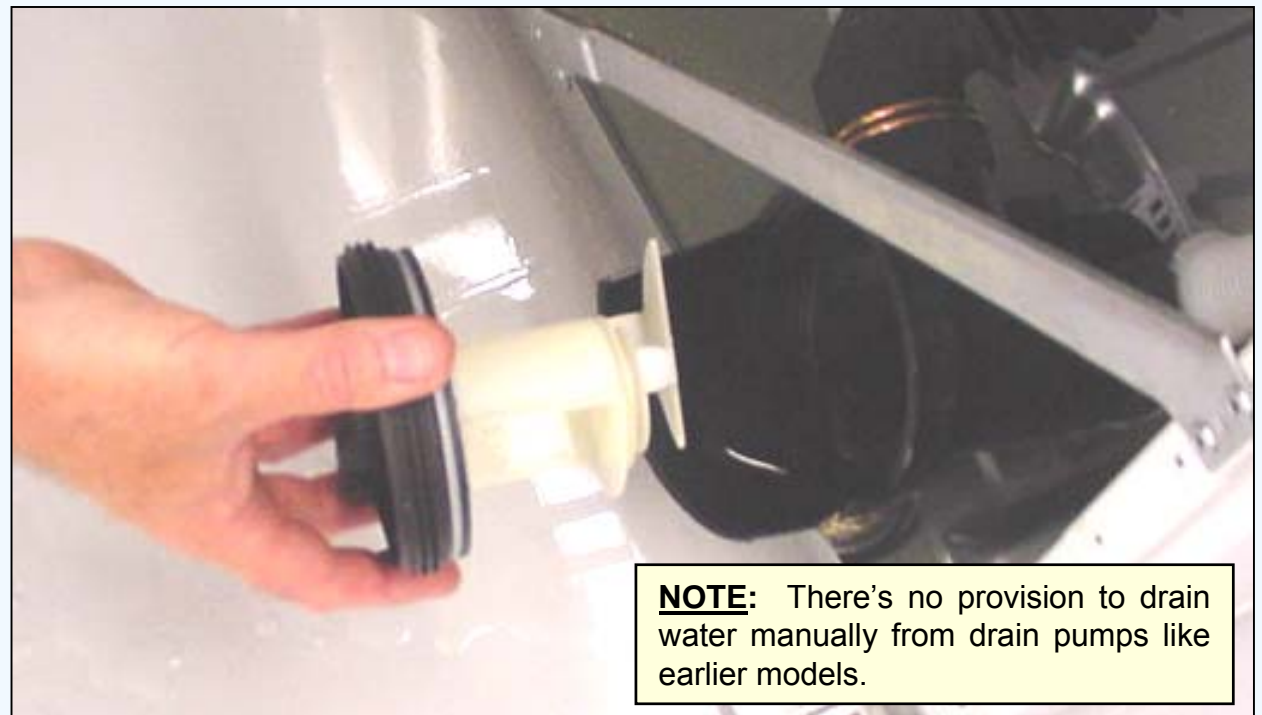

NOTE: There's no provision to drain water manually from drain pumps like earlier models.

Operation – Preventing Water Collecting in Door Seals

Unlike WFK, WFL & WFR washers, WFMC/WFXD washers have tilted tubs and flow through tub paddles to help prevent water collecting in door seals and to enhance wash water flowing through clothes.



Paddles direct water toward front of washer – water drains into paddles from outside of inner drum, flows toward front of paddles and exits holes in front of paddles onto clothing in front of washer.

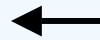

Directing water away from door seals:

- Drums are tilted to direct water to the back of the drum and away from the door seal.
- Door glass is shaped to direct water away from the door seal.
- Paddles insure clothing at front of dryer get wet despite tub being tilted toward the back.



Operation – Laundry Deflector

Unlike WFK, WFL & WFR washers, WFMC/WFXD washers have a laundry deflector to prevent small items such as socks and wash rags from collecting in door seals. Without laundry deflectors, small clothes items can get jammed in door seals and apply pressure to bottoms of doors.

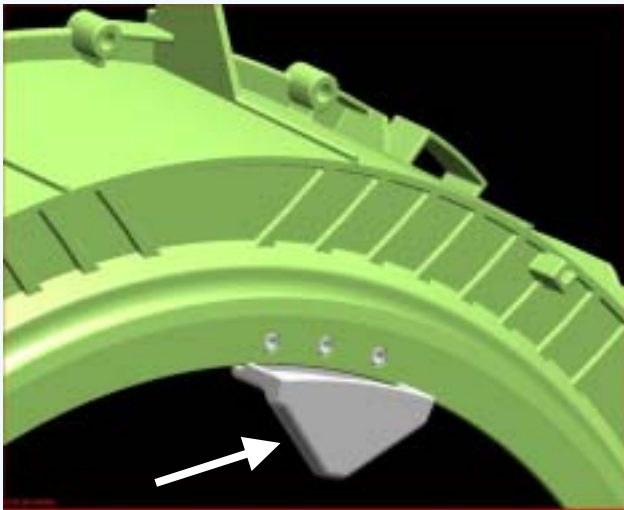

Without the laundry deflector, small clothes items being jammed in door seals would only cause minimal leakage (a few drops).

Disassembly – Fascia (Control) Panel (1)



To remove fascia panel to access control module & dispenser, remove (4) T-20 Torx front/side screws and lift panel up. Caps over screws can be removed using fingernails or a sharp knife – take care not to scratch fascia panel or caps.



When reassembling panels, tuck rear tabs under top panel 1st.



Knobs are permanently attached to panels and cannot be removed.

Disassembly – Fascia (Control) Panel (2)

Control modules can be readily removed from fascia panels, but there's a knack to it – must use the procedure below exactly as shown.



Start from left side



Pry outer & inner tabs together L – R

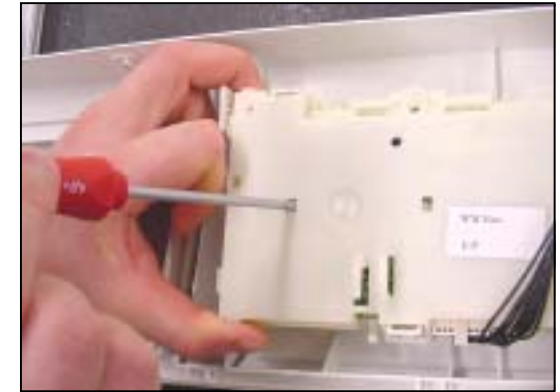

Pry out (3) inner tabs + all outer tabs



HINT: Don't force modules out from fascia panels to avoid breaking plastic parts. If modules don't come out easily, the procedure hasn't been followed and plastic parts will break.

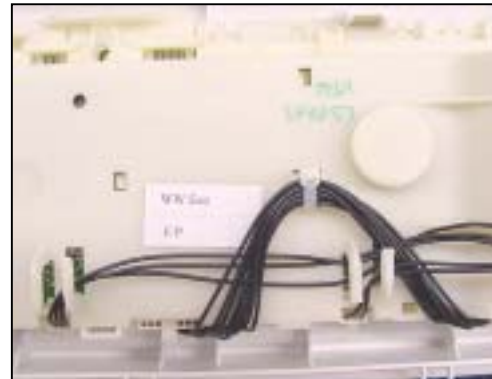

HINT: Don't remove the wire holders – clip off wire ties instead. Carry extra wire ties to reattach wire harnesses.

HINT: The knob does NOT have to be removed to remove the control module. The module lifts off completely from the panel, knob & buttons.

NOTE: Some control modules have been replaced since fault codes stored in module or motor control can't be cleared. Modules are operating properly and shouldn't be replaced to clear fault codes.

Disassembly – Top & Rear Panels (1)

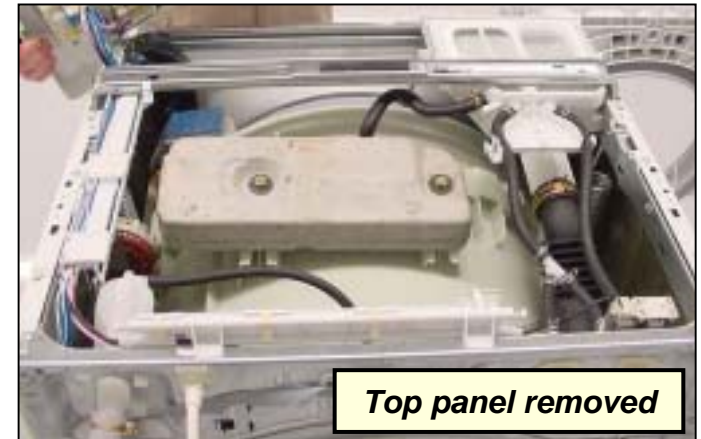
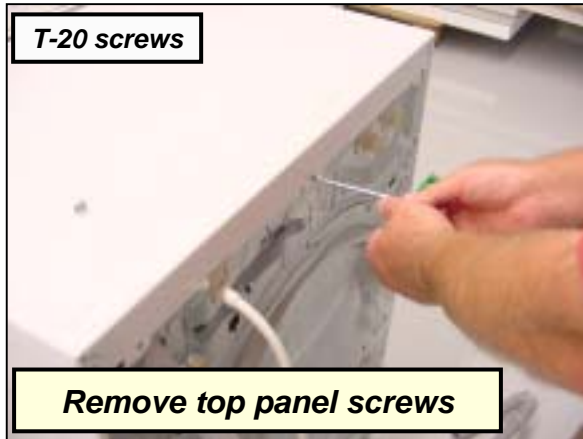

To remove rear panel to access drive motor and rear of drum, remove (18) T-20 screws. There's no need to remove the top rear panel (with "H" & "C" stampings).

To remove top panel (for easier parts access), remove (3) T-20 screws and slide panel to rear of washer.

Disassembly – Drum/Front Panel (1)



Remove hinge cover screws



Remove hinge screws



Remove door seal spring



Remove door latch screws



Carefully remove front shield



Removing front shield

Disassembly – Drum/Front Panel (2)



Remove top front panel screws



Remove bottom front panel screws

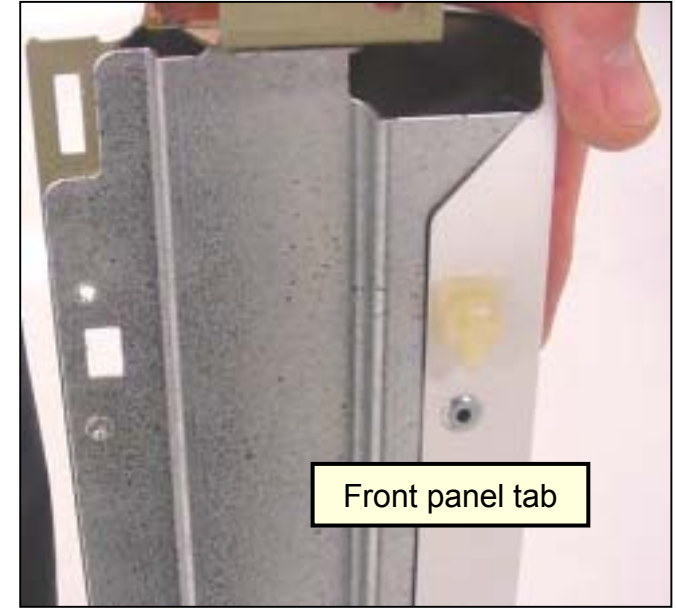

Note front panel mounting tabs



Remove front panel

HINT: Removing front panel at this point will make removing front counterweights easier.

HINT: Front panels are mounted using six (6) plastic tabs – three (3) on each side. Lift front panels up to remove them. When reassembling front panels, carefully align tabs and don't use excessive force to avoid breaking tabs.

HINT: Most washer screws require **T-20** Torx screwdrivers.

Disassembly – Drum/Front Panel (3)



Remove door latch



Note door latch manual release



Top counterweight must be removed



13mm screws

Loosen top counterweight screws



Slide out top counterweight



Note top counterweight bushing slots in tub

Disassembly – Drum/Front Panel (4)



Remove right and left front counterweight screws

Note counterweight screw bushings in tub



Remove door seal



Disconnect main water inlet hose



Disconnecting main water inlet hose

Disassembly – Drum/Front Panel (5)



Disconnect dispenser hoses



Disconnect water inlet valve hoses



Disconnect hot water valve hose



Remove dispenser screws



Remove dispenser



Disconnect drain hose

Disassembly – Drum/Front Panel (6)



NOTE: Old style drain pump shown (not used in production)

Disassembly – Drum/Front Panel (7)

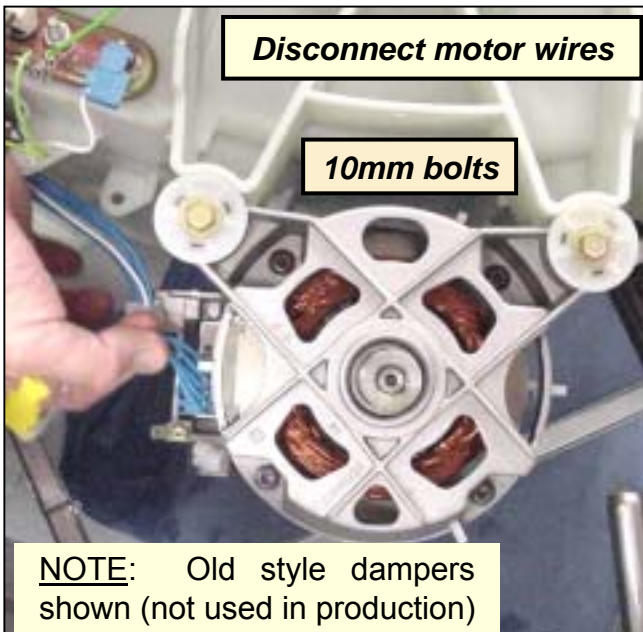
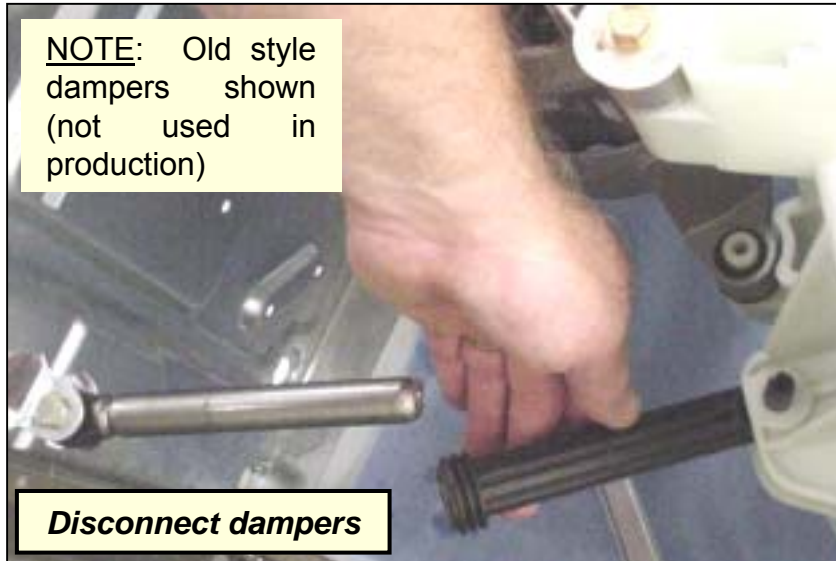

Disassembly – Drum/Front Panel (8)

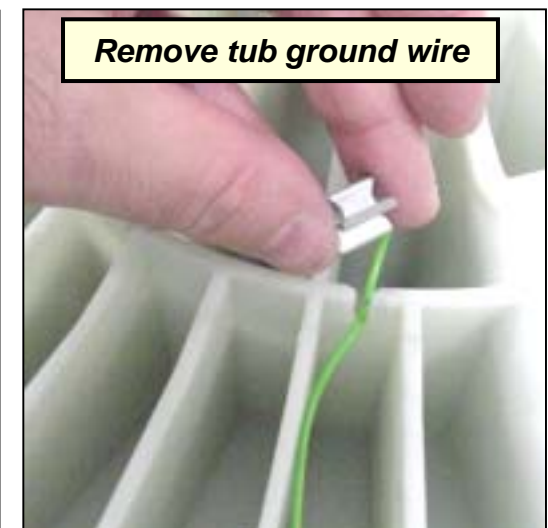
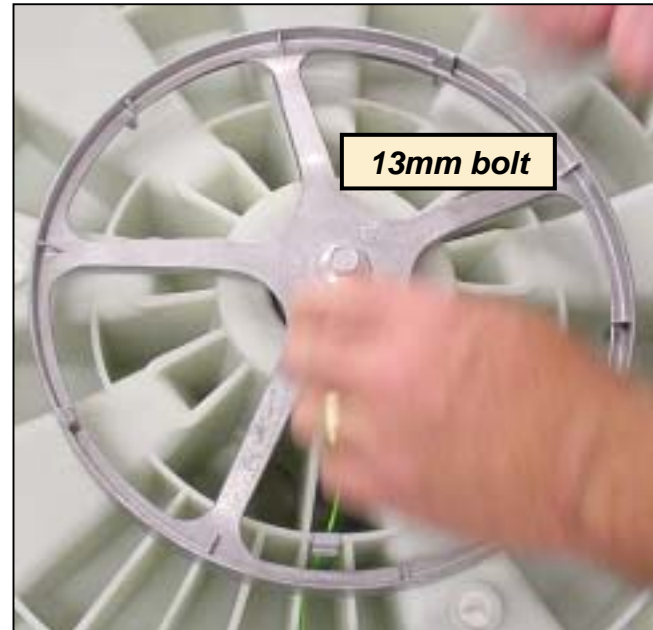

Disassembly – Drum/Front Panel (9)

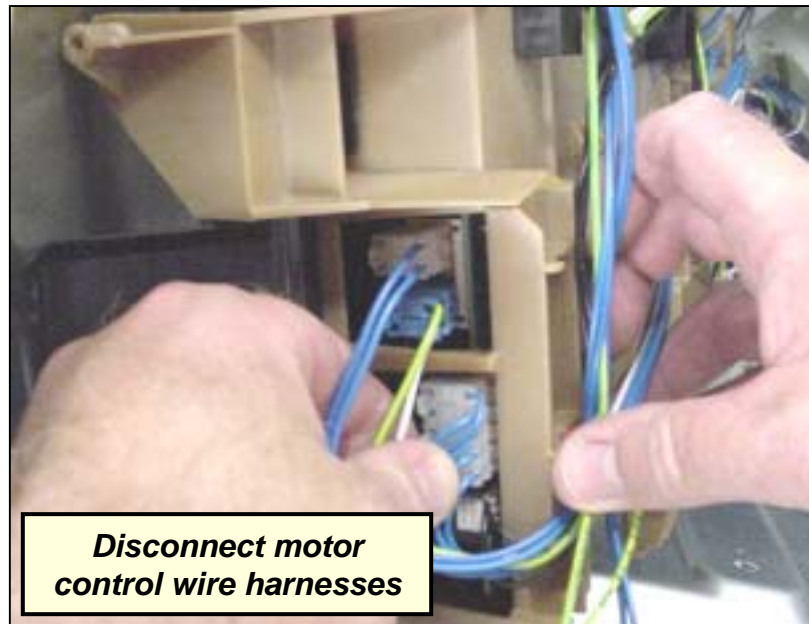
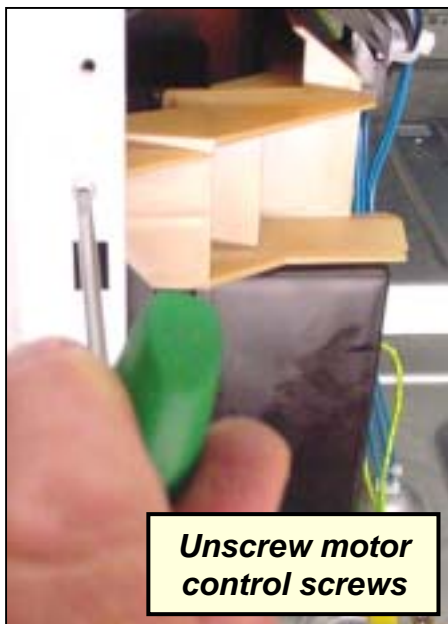
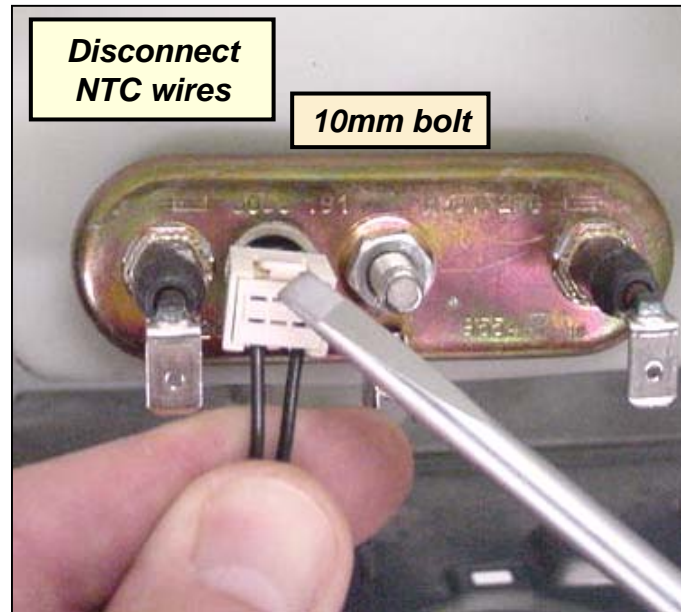
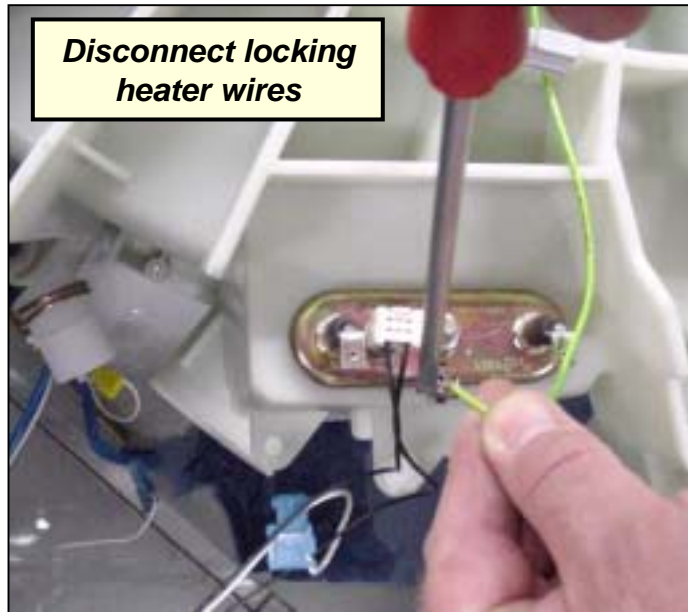

Disassembly – Drum, Outer Drum (Tub) & Dampers (1)

Outer drum (tub)

The tub consists of two durable *Polinox* plastic shells which are screwed to each other.

To remove outer tub:

1. Disconnect wire harnesses (as needed) – wire ties can be cut off, but clips shouldn't be cut.
2. Remove front panel, rear panel, fascia panel (with detergent dispenser) and top panel.
3. Remove door seal, top counterweight and both side counterweights.
4. Disconnect dampers from tub and slip belt off of tub.
5. Remove tub through rear of washer.
6. Remove (18) T-25 Torx screws holding front & rear tubs together.

NOTE: Rear drum bearings are factory press fit into rear outer tubs and cannot be removed or serviced.

HINT: When installing outer tub bolts, screw them in by hand onto the first thread. Do not overtighten or cross-thread them.

HINT: Unlike WFL2060 & WFR2460 washers, **no** clips hold tubs together – **no** drilling or cutting is needed.

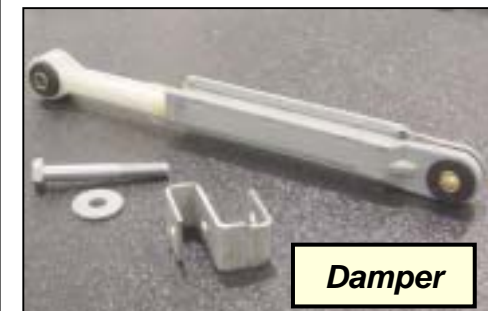
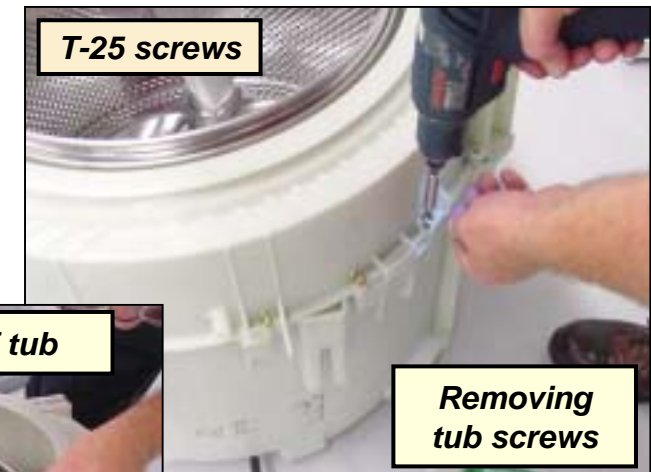

Disassembly – Drum, Outer Drum (Tub) & Dampers (2)



NOTE: Rear drum bearings are factory press fit into rear outer tubs and cannot be removed or serviced.



Disassembly – Drum Drive Motor

To remove drum drive motors:

- Remove rear panel
- Remove rear tub spring
- Remove drum belt
- Disconnect wire harnesses
- Remove two motor bolts, then pull motor out toward rear of washer

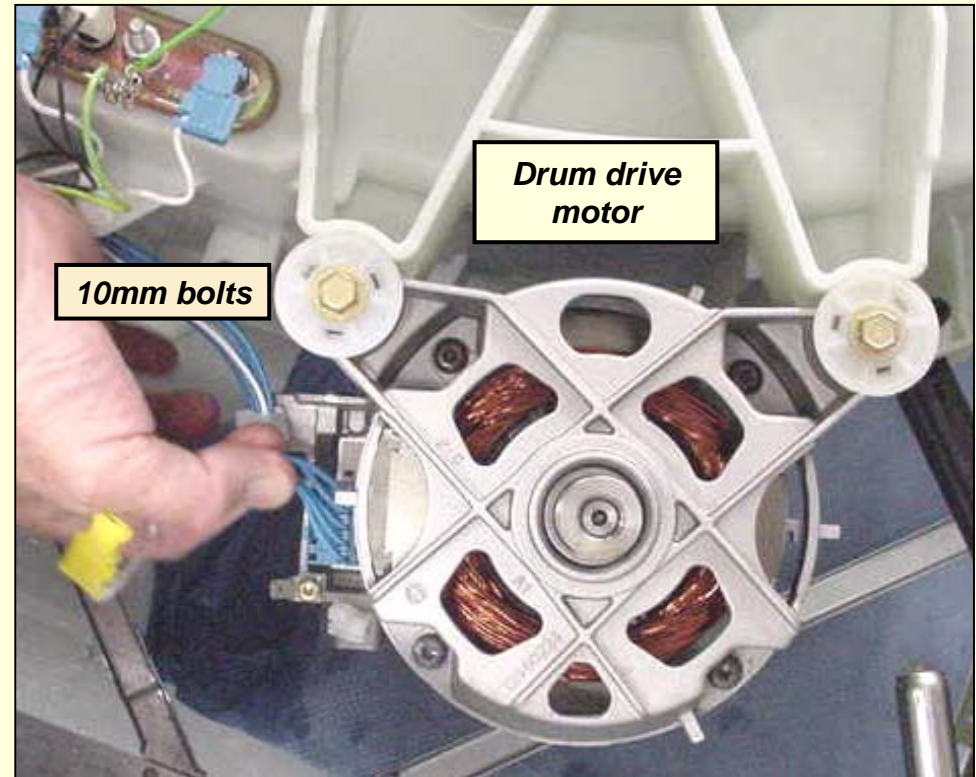
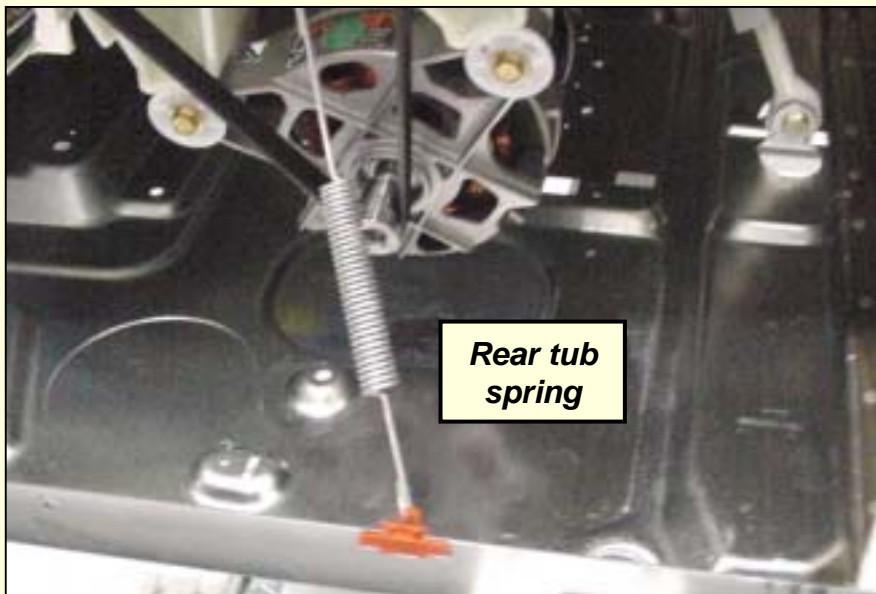

WARNING: The drum drive motor & tub are grounded through the motor control. Since the tub is plastic and the motor is isolated from the frame, its critical the ground leads from the tub, drive motor & motor control are connected properly.

Disassembly – Drain Pump

To remove drain pumps:

- Remove front panel
- Loosen and remove hoses
- Disconnect wire harness
- Carefully slide pump toward rear of washer, then lift it out of washer (taking care to not damage the four rubber feet).

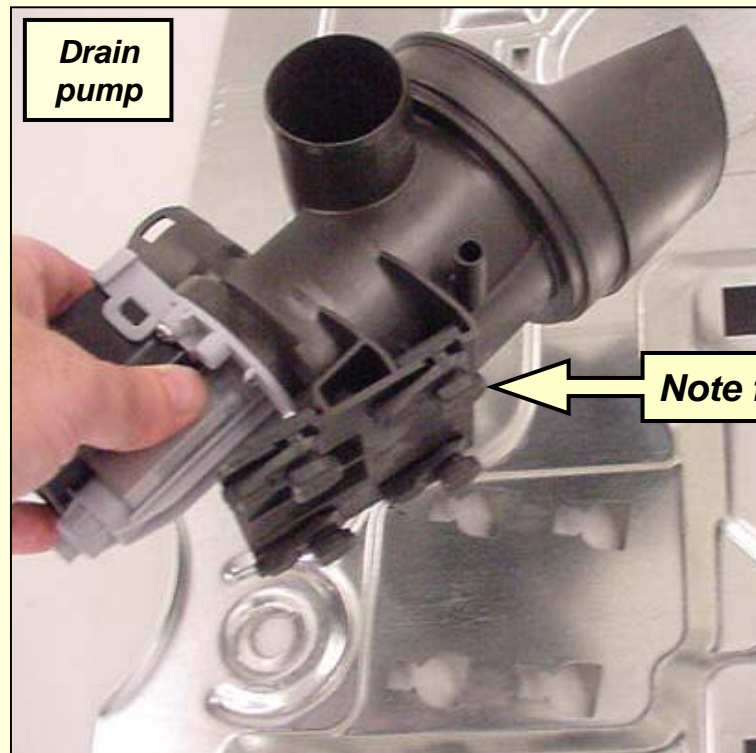

HINT: Drain pumps are mounted on four rubber feet to dampen vibration & noise. To remove drain pumps, carefully slide them toward rear of washers. To install them, carefully insert all four feet into notches in washer base, then slide them forward.

Current production pumps are beige color – earlier WFCM pumps were black.

Disassembly – Water Valves & RFI Filter

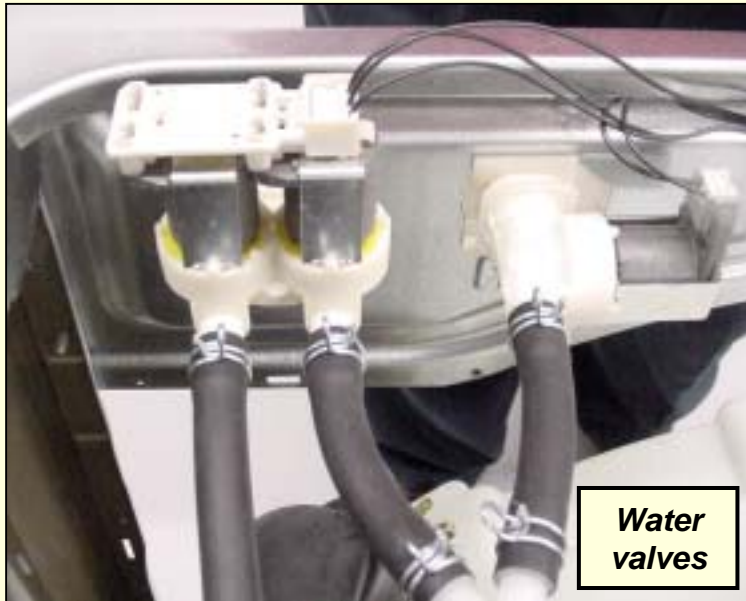

HINT: Water valves are bent and snapped into place. When removing valves, take care not to break off plastic pieces.

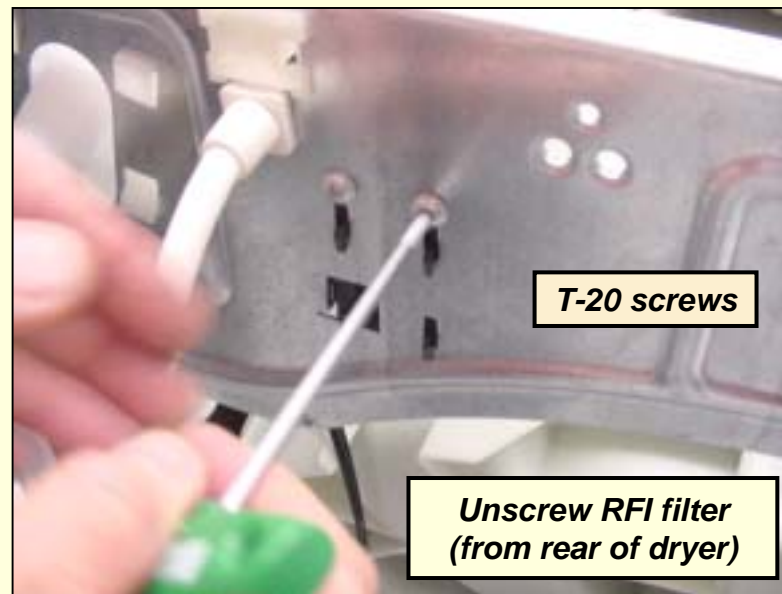

...and that's all there is to taking apart the washers!

WFMC/WFXD Service Tips – Ratings (1)

- **Ratings:** 120VAC, 15A, 60 Hz, 1350W (uses 11A max.).
- **Hot & cold water inputs:** 3/4” NPT, 14.5 – 145 psi, 2.2 gal. (8 l)/minute – 5.2 gal (19.8 l)/minute.
- **Plug:** NEMA 5-15P 120V, 15A, 3-wire.
- **Spin speeds:** 400-1000 RPM (WFMC32/WFXD52) or 400-1200 RPM (WFMC64/WXFD84).
- Three concrete vibration dampeners, one top & two front.
- Drum has five – point suspension.
- Uses *Polinox* outer drum - quieter & dent resistant compared to ss.
- UL listed (U.S. & Canada).



WFMC/WFXD Service Tips – Ratings (2)

- **Drum motor**: 120VAC, 3-phase, 850W, 400Hz variable frequency (for use with 3-phase motor control), asynchronous, class F insulated, with tachometer.
- **Heater**: 240VAC, 1000W, 8.8A, 13.7 – 15.2 W
- **Drain pump**: 120VAC, 60 Hz, 70W, class F insulated, 15 min. on / 45 min. off duty, thermally protected, isolated by four rubber feet (noise/vibration dampened).
- **Drain pump flow rate**: 18 liters/minute @ 2.5m (8') head and 30 liters/minute @ 1.25m (4') head .
- **Water levels** (cotton cycle, empty drum):
 - **1st**: 1 – 1.6 gal. (4 – 6 l); ~ 1.7" – 2.5" (43 – 65mm)
 - **2nd**: 4 – 4.5 gal. (15 – 17 l); ~ 4.5" – 5.1" (115 – 230mm)
 - **Overflow**: 15 gal. (57 l); ~ 10.6" – 11.4" (270 – 290mm)



WFMC/WFXD Service Tips – Ratings (3)

- **Door locking:** ≤ 2 sec. locking, ≤ 4 sec. unlocking.
- **NTC (R1) ratings:**
 - 36 – 44 kW@ 10°C (50°F)
 - 22.8 – 27.4 kW@ 20°C (68°F)
 - 14.8 – 17.5 kW@ 30°C (86°F)
 - 9.8 – 11.5 kW@ 40°C (104°F)
 - 6.6 – 7.7 kW@ 50°C (122°F)
 - 4.6 – 5.3 kW@ 60°C (140°F)
 - 3.73 – 4.29 kW@ 66°C (151°F)
 - 2.94 – 3.36 kW@ 73°C (163°F)
 - 1.93 – 2.19 kW@ 86°C (187°F)



WFMC/WFXD Service Tips – Infrequently Asked Questions (1)

- **Wash temperatures**: 155°F Sanitary, 150°F Temp. boost, 120°F – 125°F Hot, 90°F – 95°F Warm, 60°F – 70°F Cold.
- **Length of power cord** – 6' (72")
- **Net weight** – 216 lbs. (98 kg.)
- **Drum capacity / volume** – 3.1 ft³ (88 l) / 17.6 lbs. (8 kg.) for regular cotton
- **Pumping height (max.)** – 8' (2.4 m)
- **Dimensions** – 36.9" H x 27" W x 30.2" D (93.7 cm x 68.7 cm x 76.7 cm)
- **Energy (appendix J rating)** – EF > 4.0; uses < 284 kwh/yr.
- **Noise level (wash)** – 60 dB
- **Noise level (max. spin)** – 70 dB (WFMC32/WFXD52); 72 dB (WFMC64/WFXD84)



WFMC/WFXD Service Tips – Infrequently Asked Questions (2)

- **Door opening** – 16” (41 cm)
- **Water usage / ft³** – 8.5 gal./ft³ (WFMC32/WFXD52); 7.5 gal./ft³ (WFMC64/WFXD84)
- **Water usage:**
 - **WFMC32/WFXD52**
 - Cotton (temp boost; 4.4 lbs.) – 13.7 gal. (52 l)
 - Cotton (cold; 13.2 lbs.) – 20 gal. (75 l)
 - Permanent Press (warm; 8.8 lbs.) – 14.5 gal. (55 l)
 - Hand Wash (6.6 lbs.) – 8.5 gal. (32 l)
 - **WFMC64/WFXD84**
 - Cotton (temp boost; 4.4 lbs.) – 13.2 gal. (50 l)
 - Cotton (cold; 13.2 lbs.) – 20 gal. (75 l)
 - Permanent Press (warm; 8.8 lbs.) – 14 gal. (53 l)
 - Hand Wash (6.6 lbs.) – 10.5 gal. (40 l)



WFMC/WFXD Service Tips – Installing Door Seals

Certain repairs can involve removing or disconnecting the door seal (gasket) for access. To insure proper washer operation and prevent leaking, door seals must be reinstalled correctly.

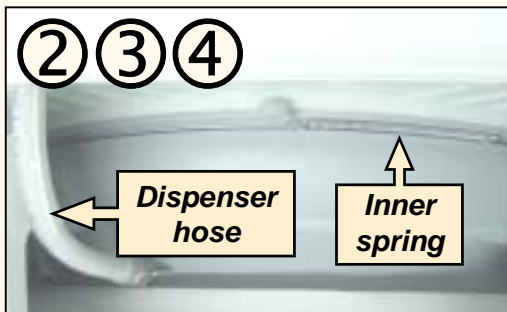
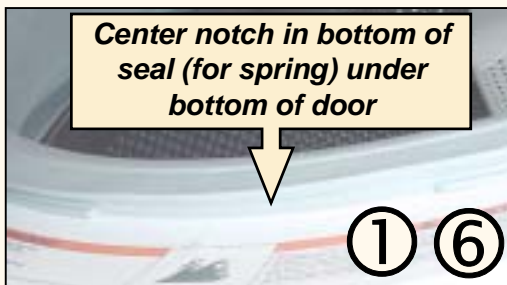
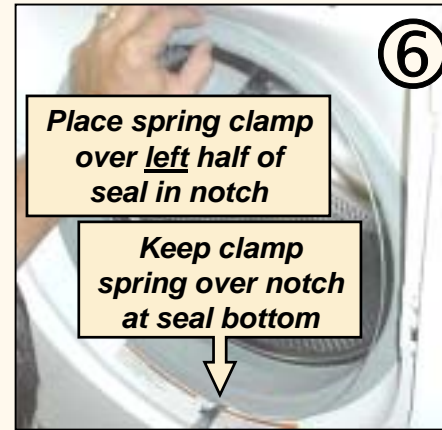

To install door seals:

- 1) Align door seal so notch (for spring) at front is centered under bottom of door.
- 2) Carefully push rear of seal over front of tub so seal properly seats onto tub.
- 3) Stretch rear spring clamp over seal and insert into notch at rear of seal.
- 4) Using small hose clamp, attach dispenser hose to seal.
- 5) Work front seal lip over front shield flange (so lip "snaps" in). Tug around entire seal to check if seated.
- 6) Align clamp spring at door bottom, then insert front spring clamp into notch of entire left half of door seal (180° from top to bottom).
- 7) While pulling right side of spring using needlenosed pliers, pull clamp into right side seal notch, then carefully release spring. Hold clamp next to front shield so clamp won't pull seal off.

NOTE: Check to make sure seal is seated after installation so no leaking will occur.

TIP: Left-handed servicers -- start the front spring clamp on the right side and pull the spring to the left.

WFMC/WFXD Service Tips – Reconnecting Harnesses

There have been occasions when wire harnesses have not been reconnected after repairs have been made, especially for harnesses disconnected to make easier access to repair other parts. It's important that all wire harnesses are reconnected and checked when any repairs are made.

Examples of wire harnesses that can be left disconnected:

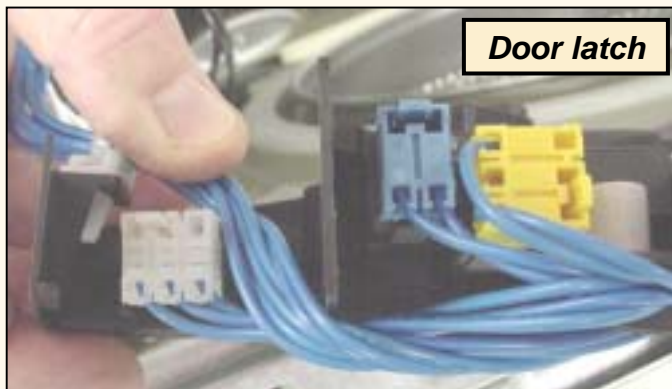

Door latch

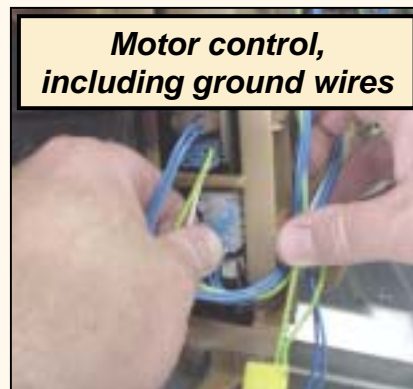

**Motor control,
including ground wires**

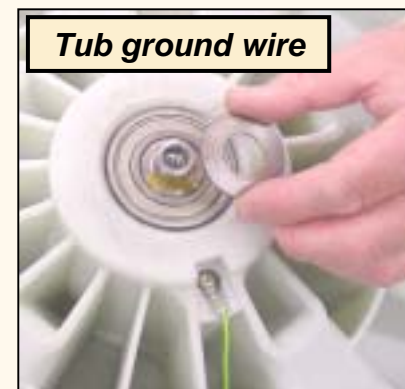

Tub ground wire

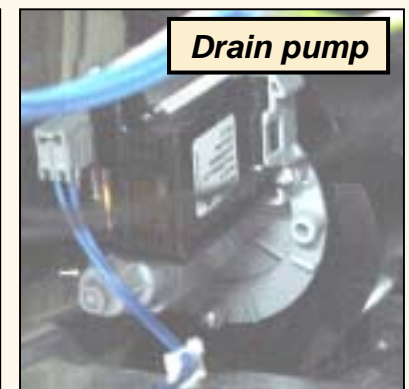

Drain pump

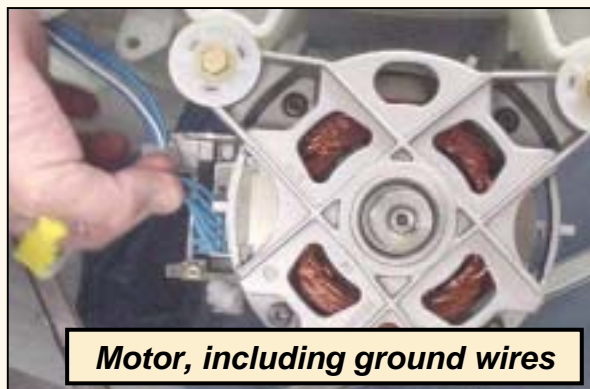

Motor, including ground wires

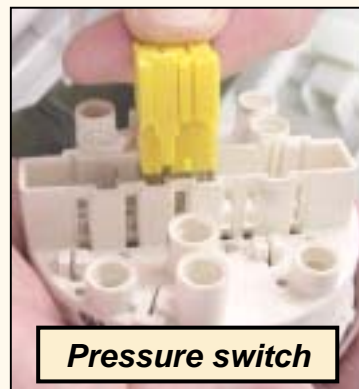

Pressure switch

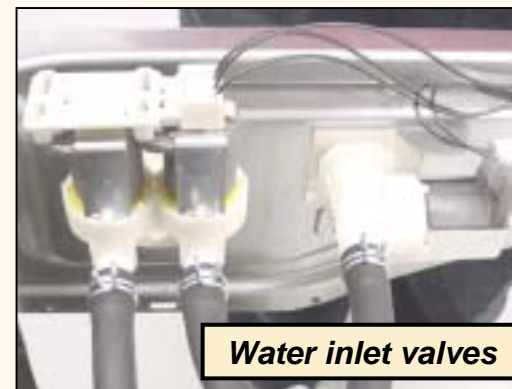

Water inlet valves

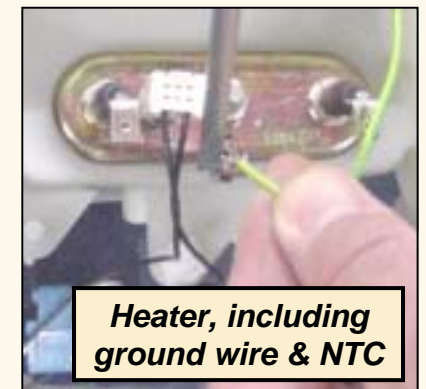

**Heater, including
ground wire & NTC**

HINT: Write down all harnesses disconnected during repairs, then check all harnesses after repairs have been made.

HINT: If needed, run test P:3 (P:03) and visually check all parts are functioning properly.

WFMC/WFXD Service Tips – Drum Drive Motor

Motor control (on left side viewing rear of washer)

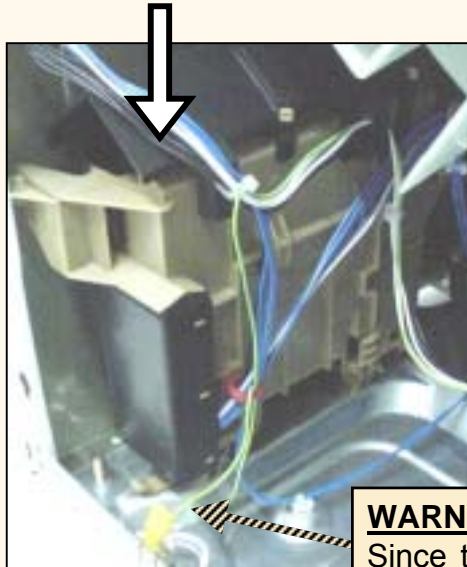

Drum motor resistances:

- X2 Motorstecker motorconnector
- M2 Motor-Wasch./Schl. motor-wash/spin
- X2. 8-7 1,8 Ω ... 2,1 Ω
 - X2. 6-7 1,8 Ω ... 2,1 Ω
 - X2. 6-8 1,8 Ω ... 2,1 Ω
 - X2. 4-5 180 Ω ... 220 Ω

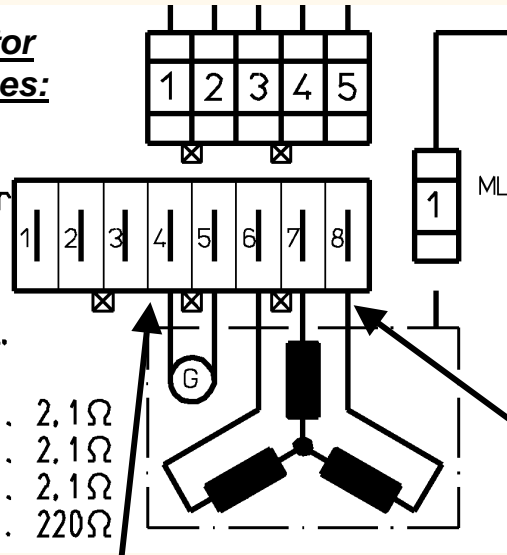

Unlike previous washers, drum drive motors are 3-phase & are controlled by separate motor controls mounted on the base near the motors (in the right rear of washers). These controls provide motor power & speed control.

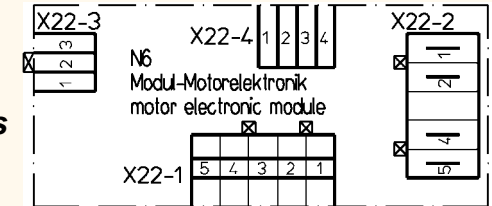

Speed tachometer connections

WARNING: The drum drive motor & tub are grounded through the motor control. Since the tub is plastic and the motor is isolated from the frame, its critical the ground leads from the tub, drive motor & motor control are connected properly.

3 Motor control

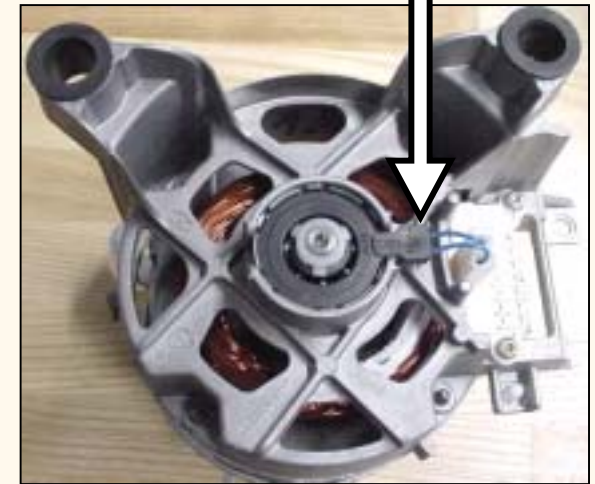
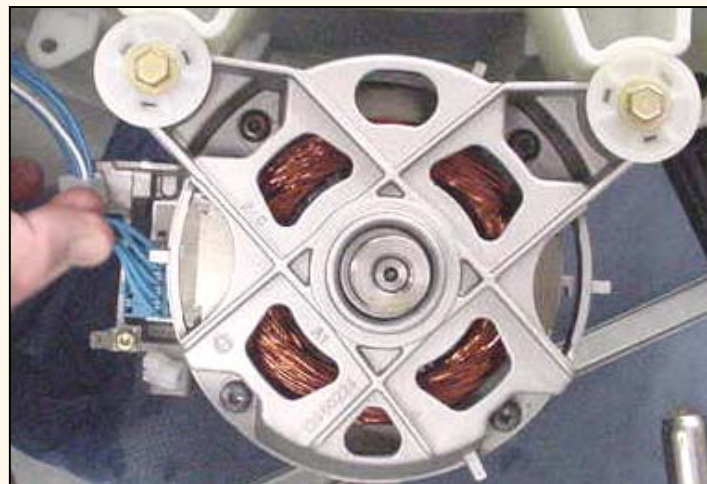
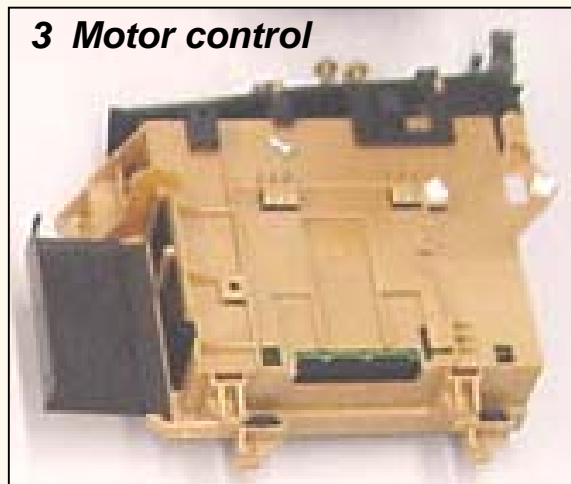

Speed sensor

WFMC/WFXD Service Tips – Drain Pump

Drain pumps reliably pump water out from washer tubs through the drain reservoir and drain hose. Unlike earlier washers, these pumps are maintenance free -- access to remove debris is only meant for servicers.

HINT: To remove the drain pump access cover, insert a pointed object (or tool) into the hole, push in to release the latch and rotate the cover clockwise.

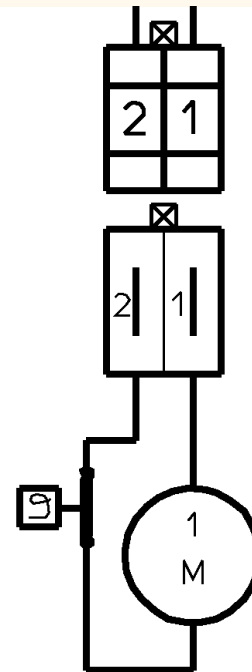
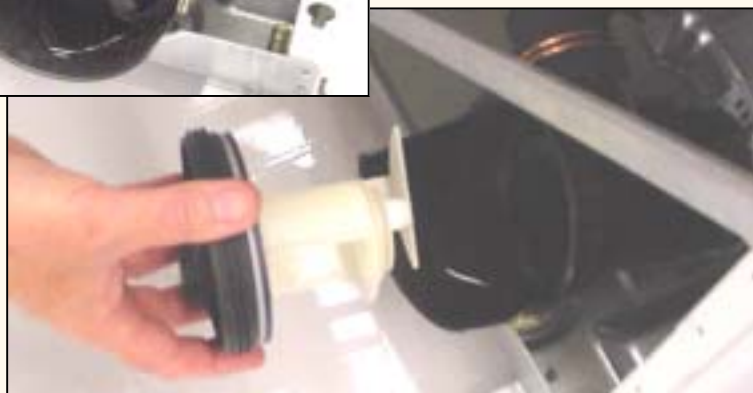
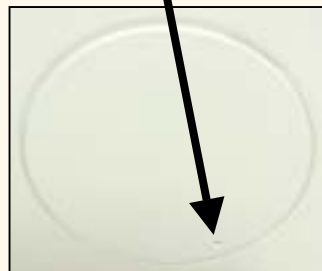

M3
Motor-Pumpe
motor-pump
140 Ω... 200 Ω

NOTE: Drain pump motor resistance ranges from 140 – 200 . Its rated @ 120VAC, 60 Hz, 70W.



HINT: Drain pumps are mounted on four rubber feet to dampen vibration & noise. To remove drain pumps, carefully slide them toward rear of washers. To install them, carefully insert all four feet into notches in washer base, then slide them forward.

NOTE: There's no provision for draining residual water from drain pumps.

Current production pumps are beige color – earlier WFMC pumps were black.

WFMC/WFXD Service Tips – NTC & Heater

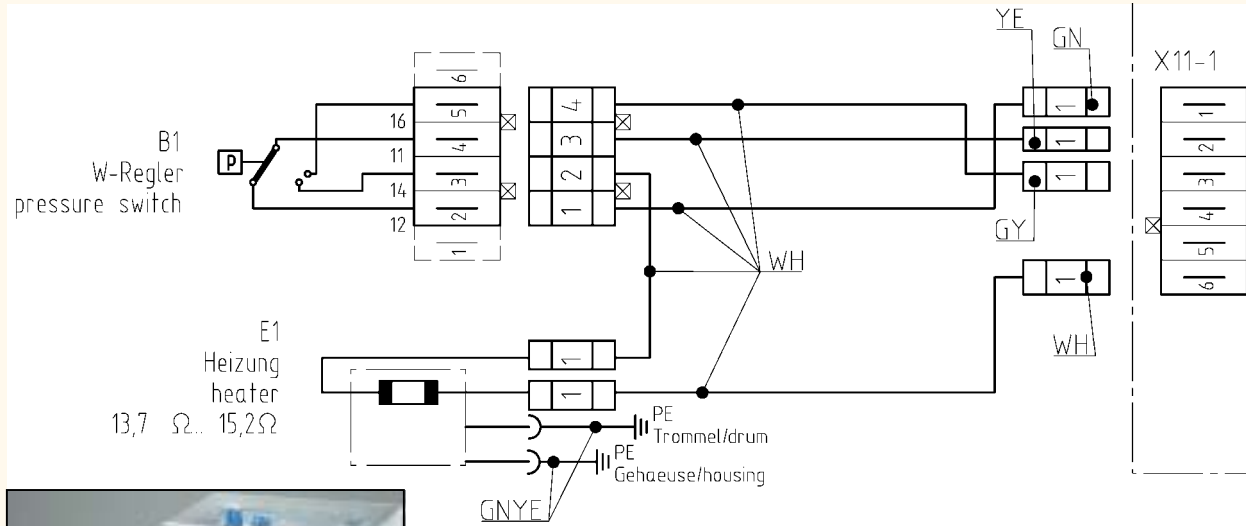

10°C (50°F):	36 – 44kW
20°C (68°F):	22.8 – 27.4kW
30°C (86°F):	14.8 – 17.5kW
40°C (104°F):	9.8 – 11.5kW
50°C (122°F):	6.6 – 7.7kW
60°C (140°F):	4.6 – 5.3kW
66°C (151°F):	3.73 – 4.29kW
73°C (163°F):	2.94 – 3.36kW
86°C (187°F):	1.93 – 2.19kW

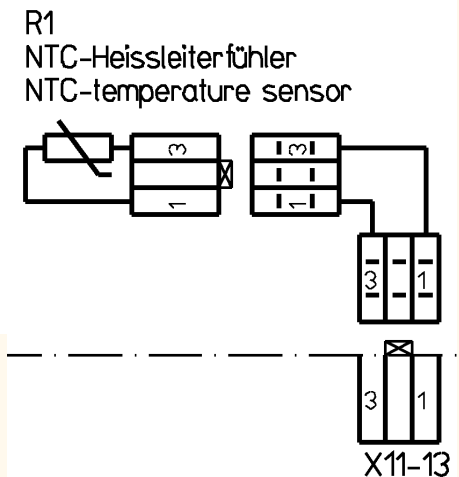

HINT: Heater can be removed from the back of the tub – remove rear panel for access.

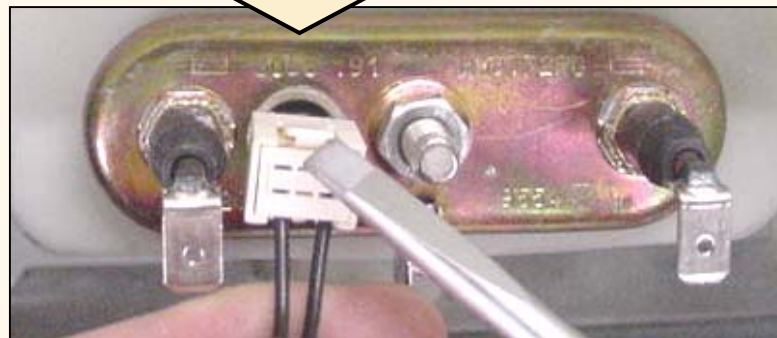

HINT: NTC connector is latched – carefully pry latch with small blade screwdriver to remove it.

WFMC/WFXD Service Tips – Door Lock



Door lock

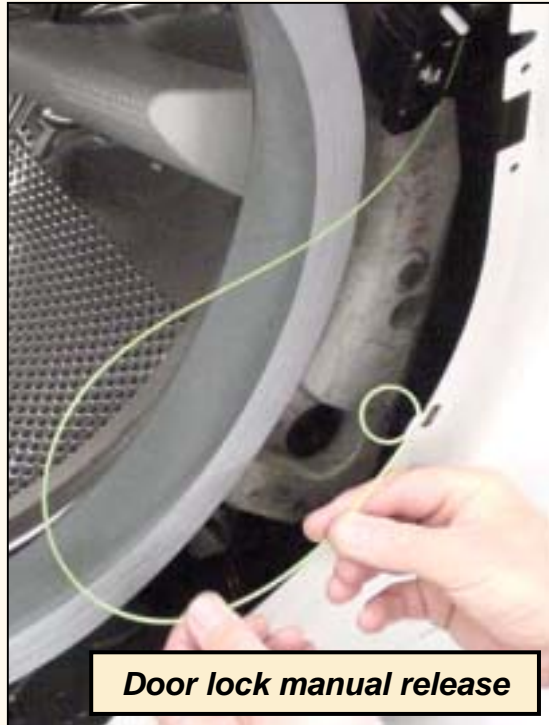

Door lock manual release

HINT: Can remove fascia panel & front shield to access door lock.

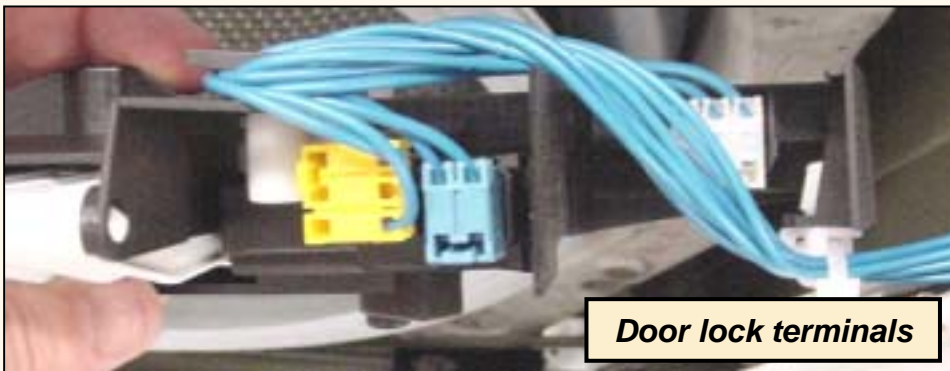

Door lock terminals

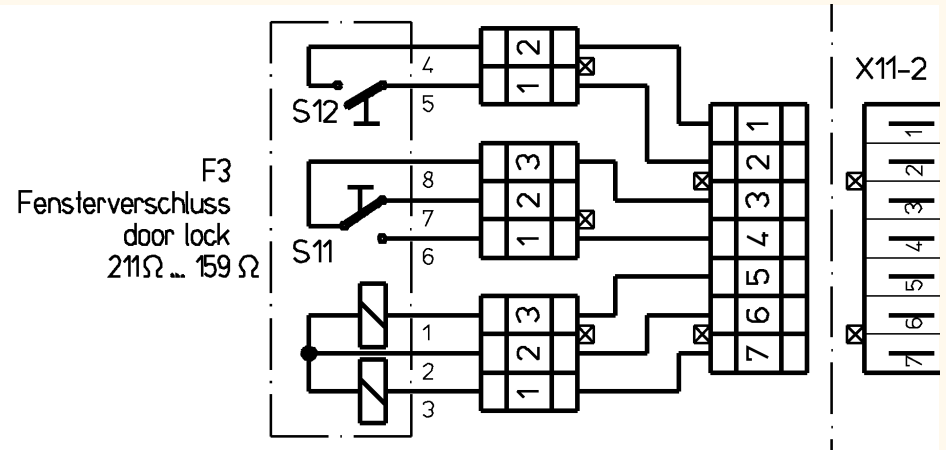

HINT: To remove the access cover to use the door lock manual release, insert a pointed object (or tool) into the hole, push in to release the latch and rotate the cover clockwise.

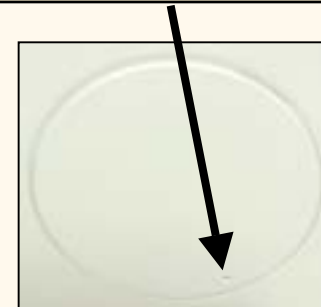

HINT: Door lock manual release cable is held to the right side of the drain pump by a clip. Simply pull on the cable to release the door.

WFMC/WFXD Service Tips – Resetting Door Locks (1)

Occasionally door locks stay locked when doors are opened while they're locked, preventing doors from closing. Please follow these instructions to reset door locks.



Remove front seal spring



Move door seal for access



Push onto back of door lock until it clicks open

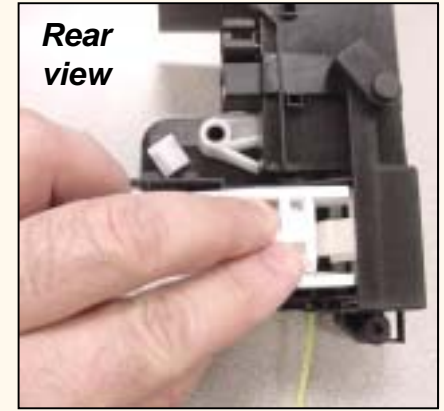

Rear view

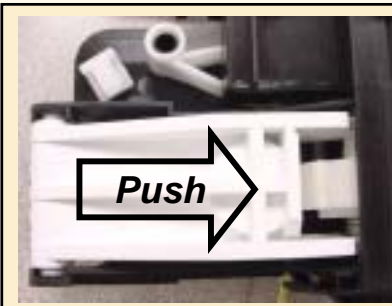

HINT: Reach around back of door lock (opposite latch opening) and push onto back of lock plate (directly behind latch) until it clicks.



Door lock latched



Door lock open

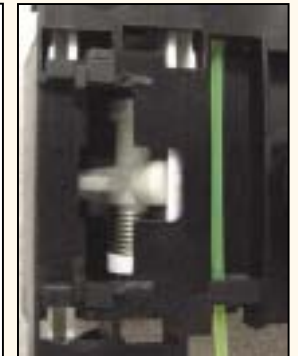
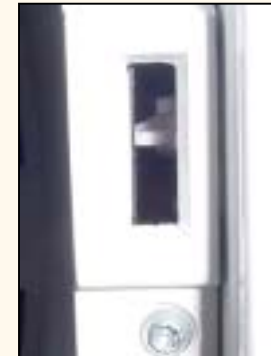

HINT: If lock doesn't release, pull green manual door release cord (down) and push onto back of lock a 2nd time.

NOTE: Advise customers against pulling doors open while locked.

WFMC/WFXD Service Tips – Resetting Door Locks (2)

There are three ways to reset door locks (shown below) – each has advantages & disadvantages:

1. **Access past door seal (shown on previous page)** – eliminates any chance of cosmetic damage, but requires reattaching door seal spring (which can be tricky).
2. **Access from top panel** – provides access to door lock without removing door seal, but allows scratching of fascia panel and screw caps. To access door lock from top, remove (4) fascia panel screw caps, remove (4) fascia panel screws and carefully lift fascia panel up.
3. **Pulling door lock latch out** – provides quickest repair & doesn't require removing parts for access, but allows scratching of door lock. To pull latch out, reach into lock with a strong steel loop, place loop behind latch and pull latch out. Some force is required.

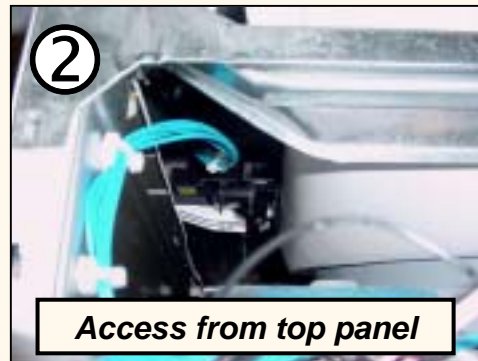

HINT: Tub is suspended from springs and can easily be moved back for better access.

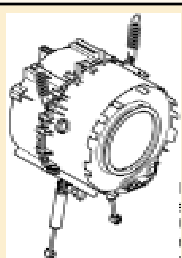

NOTE: Doors can become misaligned if leaned on heavily. Advise customers against leaning on doors for support.



HINT: Locked doors open when door latches aren't properly seated into door locks. Adjust door until latch fits properly into door lock.

WFMC/WFXD Service Tips – Replacing Door Locks

Some door locks on units made on or before 2/13/04 may not hold properly. Replace them (as shown below):

- 1. Acceptable door locks** – Those showing “N” at end of # on end of housing. If # end of housing doesn't show “N”, then those showing “1” on black housing and “1”, “2” or “3” on white carrier (see below).
- 2. Door locks to be replaced** – Those not showing “N” at end of # on end of housing and showing “2” on black housing and “4” on white carrier (see below).

- **GOOD** -- “N” at end of # on end panel (e.g. 502042N)
- **REPLACE** -- “N” not at end of # on end panel (e.g. 350031C)

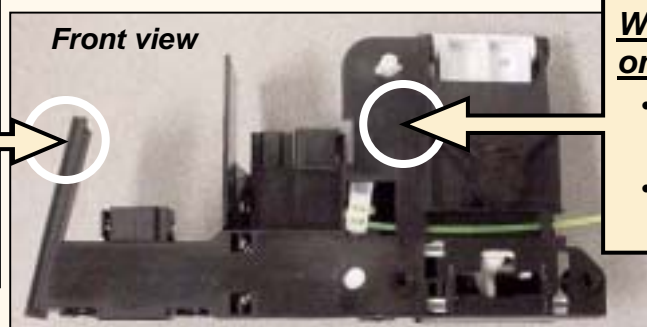

When “N” isn't on end panel #:

- “1”, “2” or “3” -- is acceptable
- “4” -- should be replaced

When “N” isn't on end panel #:

- “1” -- is acceptable
- “2” -- should be replaced

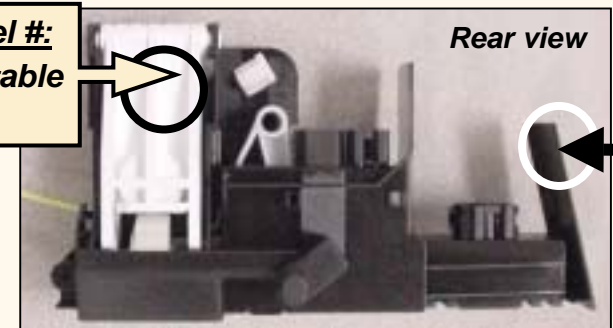

Procedure on replacing door locks:

1. Remove fascia panel by removing (4) screws (and plastic screw caps). Carefully lay fascia panel out of the way (on top panel).
2. Using a thin tool (e.g. awl or drill bit), push latch on circular drain pump access cover (through small hole in cover), then rotate cover (cw) clockwise to remove it. Disconnect green door lock manual release cable from drain pump (so door lock can be removed).
3. Remove (2) screws holding door lock to front panel.
4. Gently pry out white plastic front shield until it pops off front panel, then slide lock to left until black plastic lock rails clear notch in front frame.
5. Disconnect (3) wire harness connectors from door lock.

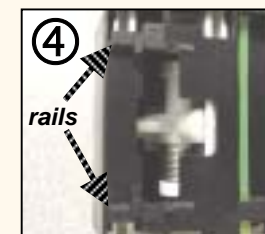
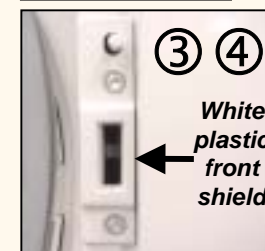

HINT: Door lock manual release cable is held to the right side of the drain pump by a clip.



WFMC64/WFXD84 Service Tips – Water Flow Meter

Flow sensor

The flow sensor measures the volume of (cold) water flowing into the detergent dispenser. It consists of an impeller wheel with a magnet core and a Hall integrated circuit. When the wheel rotates, the magnet emits impulses to the Hall IC.

The water flow is marked by an arrow on the side of the sensor.

Specifications:

- Voltage: 12 VDC
- Detected flow rate: 0 – 10 liters/minute

NOTE: If there's air bubbles in the water, higher flow rates may be detected.

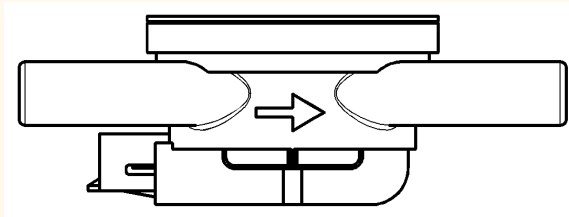
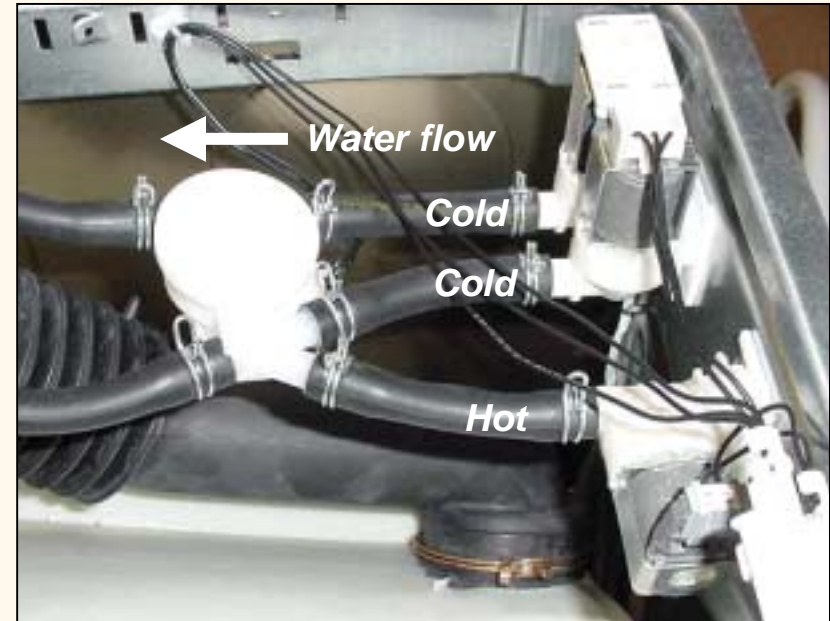

Water flow arrow

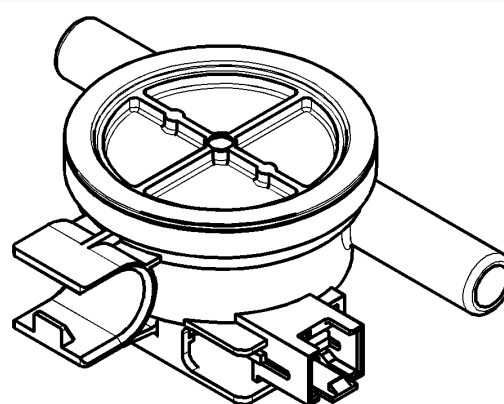

HINT: Make sure the water flow arrow points from the water inlet valve to the dispenser.

WFMC64/WFXD84 Service Tips – Mechanical & Analog Pressure Switches

The water level (pressure switch) system consists of a mechanical pressure switch and an analog pressure switch.

Mechanical Pressure Switch

The mechanical pressure switch (*brown*) has (3) switching positions:

- Water level < level 1
- Water heating level
- Overflow level

Analog Pressure Switch

The analog pressure switch (*black*) determines the different water levels in the various wash programs. It is piezo-electric (pressure on it generates a voltage) and generates between 0.5 - 3.5 VDC.

HINT: Its not helpful to measure the analog pressure switch voltage because its shown on the digital display while the washer is in the test program.

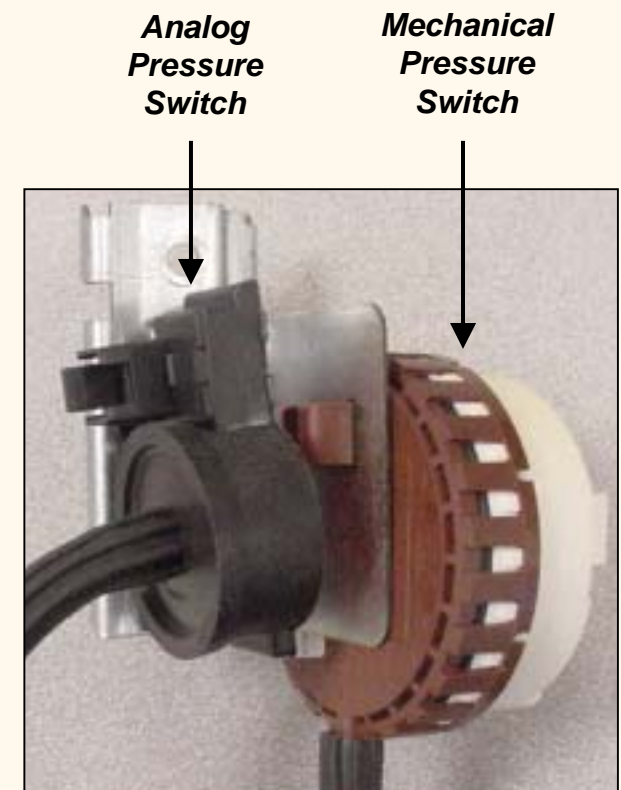

WFMC/WFXD Service Tips – Polinox Outer Drum (Tub)

POLINOX TUB

Lifecycle Test 4000 washes = 10 years
Highest spin 300 consecutive times (wash-spin, wash-spin, etc. -
have tested up to 900 wash-spin cycles)

Heat Resistant Up to 130°C (266°F)

Stability Dropped from a great height, won't dent like Stainless Steel – is
used on Mercedes-Benz bumper

- Reinforced with glass fiber
- Extraordinary strength
- Very reliable
- Vibrates less/ less noisy
- Fewer parts
- Lower weight

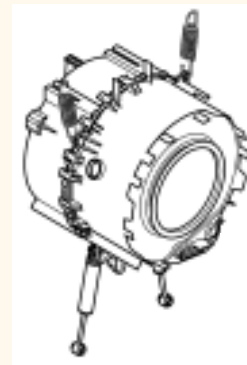

Suspension Five – point (two top springs, two dampers, one rear spring)

WFMC32/WFXD52 Service Tips – Control Module Wire & Terminal Colors

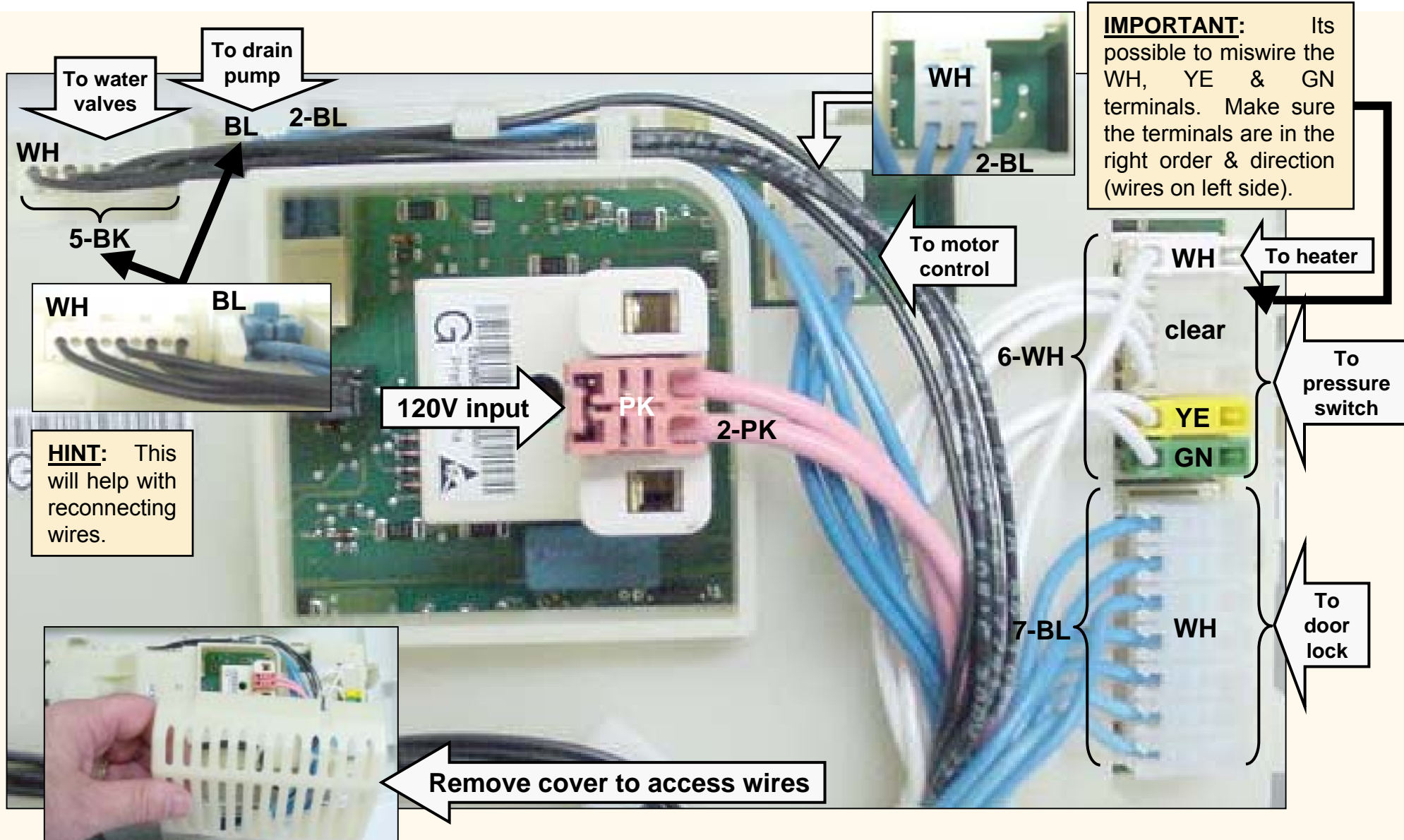

HINT: This will help with reconnecting wires.

IMPORTANT: Its possible to miswire the WH, YE & GN terminals. Make sure the terminals are in the right order & direction (wires on left side).



Remove cover to access wires

WFMC64/WFXD84 Service Tips – Control Module Wire & Terminal Colors

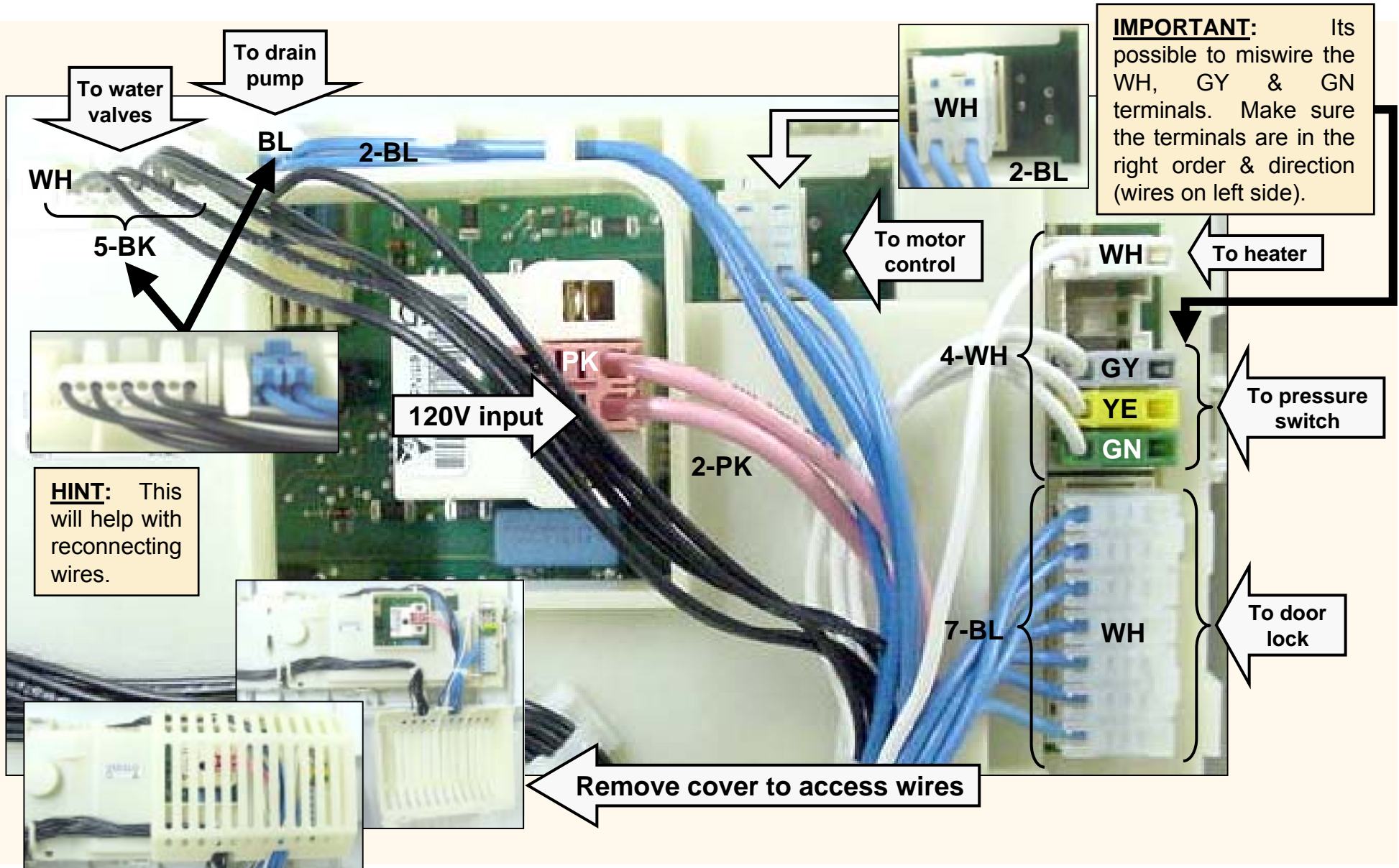

WFMC/WFXD Service Tips – Test Program

(1A): Starting WFMC32/WFXD52 Test Program

The **WFMC32/WFXD52** washer test programs self-diagnose problems, including listing the last **8** fault codes from the control module & the last **16** fault codes from the motor control. The tests are easy to use, speeding up and simplifying diagnosing washer issues.

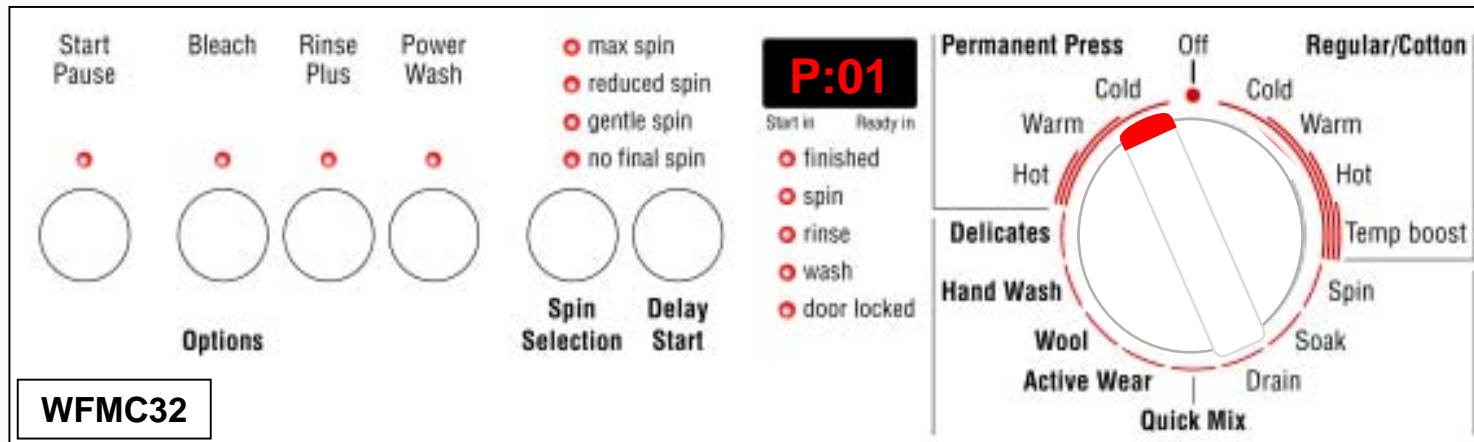

NOTE: Door locks for all water fill and drain tests.

HINT: If **Start/Pause** light doesn't come on for some tests, door is open. Turn off washer, then close door.

Entering & using WFMC32/WFXD52 test programs:

- To reset, rotate cycle selector knob to **Off** position.
- To enter test program, push and hold **Spin Selection** and **Delay Start** buttons at the same time, then rotate cycle selector knob **ccw** to **Permanent Press Cold** position. Hold **Spin Selection** and **Delay Start** buttons until **P:01** shows in display.
- To select tests, push **Spin Selection** button (to scroll through tests) until desired test shows in display (**P:01 - P:17**) - **Start/Pause** light will flash.
- To start tests, push **Start/Pause** button while its light is flashing -- light stays lit when test has started. To end tests, push **Spin Selection** button.
- To exit test program, rotate cycle selector knob to **Off** position.

WFMC/WFXD Service Tips – Test Program (1B): Starting WFMC64/WFXD84 Test Program

The **WFMC64/WFXD84** washer test programs self-diagnose problems, including listing the last **8** fault codes from the control module & the last **16** fault codes from the motor control. The tests are easy to use, speeding up and simplifying diagnosing washer issues.

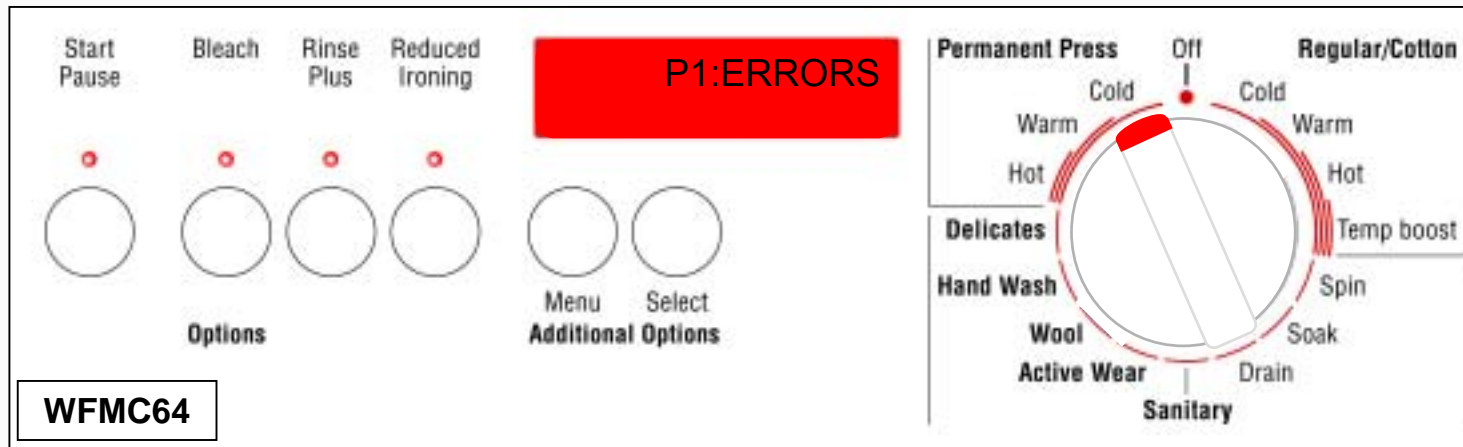

NOTE: Door locks for all water fill and drain tests.

HINT: If **Start/Pause** light doesn't come on for some tests, door is open. Turn off washer, then close door.

Entering & using WFMC64/WFXD84 test programs:

- To reset, rotate *cycle selector knob* to **Off** position.
- To enter test program, push and hold **Menu** and **Select** buttons at the same time, then rotate *cycle selector knob* **ccw** to **Permanent Press Cold** position. Hold **Menu** and **Select** buttons until **P1: Errors** shows in display.
- To select tests, push **Menu** button (to scroll through tests) until desired test shows in display (**P1 - P17**) - **Start/Pause** light will flash.
- To start tests, push **Start/Pause** button while its light is flashing -- light stays lit when test has started. To end tests, push **Menu** button.
- To exit test program, rotate *cycle selector knob* to **Off** position.

WFMC/WFXD Service Tips – Test Program (1C): Choosing Tests

Understanding WFMC/WFXD test programs:

1. Generating fault codes: Most fault codes are generated by running specific tests.
2. Viewing fault codes: Fault codes are viewed only by running test **P1** (WFMC64/WFXD84) / **P:01** (WFMC32/WFXD52), not during each test.
3. Procedure: **1st** - select test based on expected problems (see below). **2nd** - run test. **3rd** - go back and run test **P1 (P:01)** to see faults. Scroll through each fault and check if it occurred.

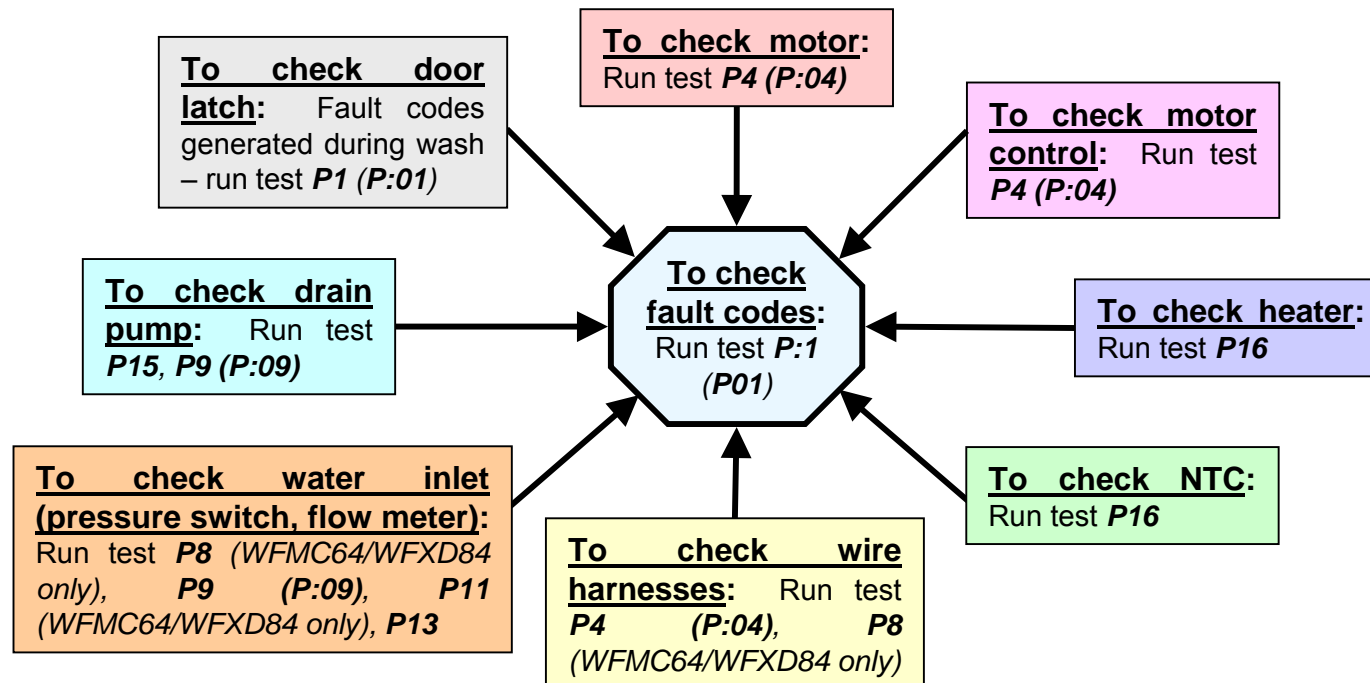

HINT: To run tests, push **Start/Pause** button.
To end tests, push:

- **Menu** button (WFMC64/WFXD84)
- **Spin Selection** button (WFMC32/WFXD52)

HINT: To scroll through tests, push:

- **Menu** button (WFMC64/WFXD84)
- **Spin Selection** button (WFMC32/WFXD52)

WFMC/WFXD Service Tips – Test Program (1D): Displaying Selected Tests

All washers have displays showing what test has been selected.

Test #	Test	WFMC32/ WFXD52 Displays	WFMC64/WFXD84 Displays	Generates Fault Codes
1	Display fault codes	P:01	P1:ERRORS	No
2	Safety test (don't run)	P:02	P2:SAFETY	No
3	Automatic test program	P:03	P3:AUTOM	No
4	Motor	P:04	P4:MOTOR	Yes
5	Model coding (variations) - don't run	P:05	P5:VARIANT	No
6	Displays & lights	P:06	P6:DISPLAY	No
7	Selector knob	P:07	P7:SELECTOR	No
8	Analog water level sensor	<i>Test not available</i>	P8:NIVEAU1	Yes
9	Pressure switch	P:09	P9:NIVEAU2	Yes
11	Flow meter	<i>Test not available</i>	P11:FLOW	Yes
12	Update control programming (N/A)	P:12	P12:UPDATE	No
13	Water valve 1	P:13	P13:VALVE1	Yes
14	Buzzer	P:14	P14:BUZZER	No
15	Pump	P:15	P15:PUMP	Yes
16	Heater & NTC	P:16	P16:HEATER	Yes
17	Noise (factory test - don't run)	P:17	P17:NOISE	No

P:03

WFMC32/WFXD52 Displays

P3:AUTOM

WFMC64/WFXD84 Displays

HINT: Skip tests
2, 5, 12 & 17.

WFMC/WFXD Service Tips – Test Program (1E):

WFMC64/WXFD84 Text Displays

WFMC64/WFXD84 washers have full text displays showing which devices are running at each point during each test. They're helpful for visually determining whether washers are properly filling, draining & spinning.

Displays in test program

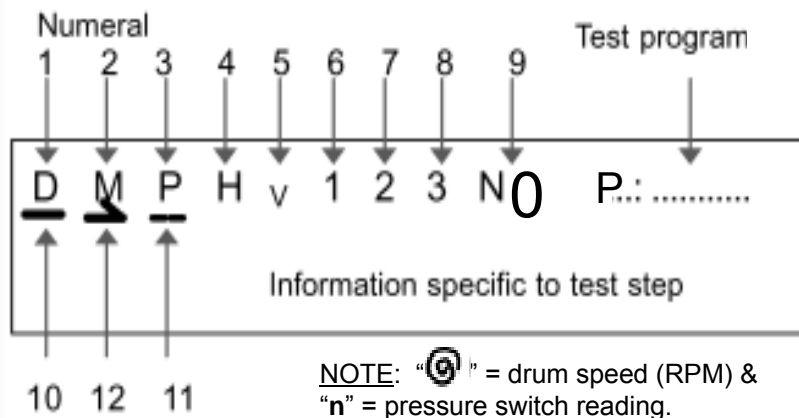

NOTE: "n" = drum speed (RPM) & "n" = pressure switch reading.

HINT: Using the test program can cut down repair times & eliminate repeat calls from misdiagnosing problems.

HINT: If **Start/Pause** light doesn't come on for some tests, door is open. Turn off washer, then close door.

Numeral	Displayed letter	Component/Function
1	D	Door
2	M	Motor
3	P	Pump
4	H	Heater
5	V	Valve
6	1	Cold water valve (1) - part of dual valve
7	2	Cold water valve (2) - part of dual valve
8	3	Hot water valve (3)
9	N ₀	No water -- below heating water level
9	N _H	Heating water level (min. to heat)
9	N _D	Door water level (reached door)
10	—	Component actuated
11	Component not actuated
12	➔	Clockwise rotation (cw)
12	➔	Counterclockwise rotation (ccw)

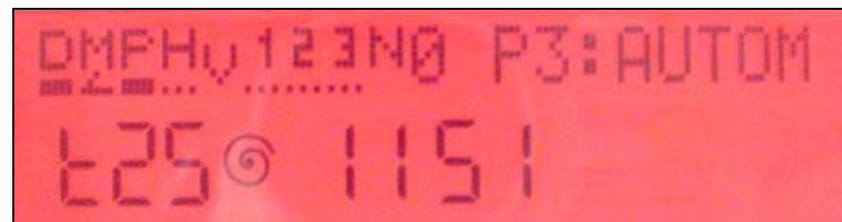

WFMC/WFXD Service Tips – Test Program (2A): Fault Code Displays

Viewing fault codes:

- WFMC32/WFXD52 displays alternate between fault code (e.g. **E:01**) & when fault occurred on in last 8 washes (e.g. **C:00**) – shows **C:00** if fault didn't occur.
- WFMC64/WFXD84 displays show fault code & when fault occurred on in last 8 washes (e.g. **0 - Er:01**).

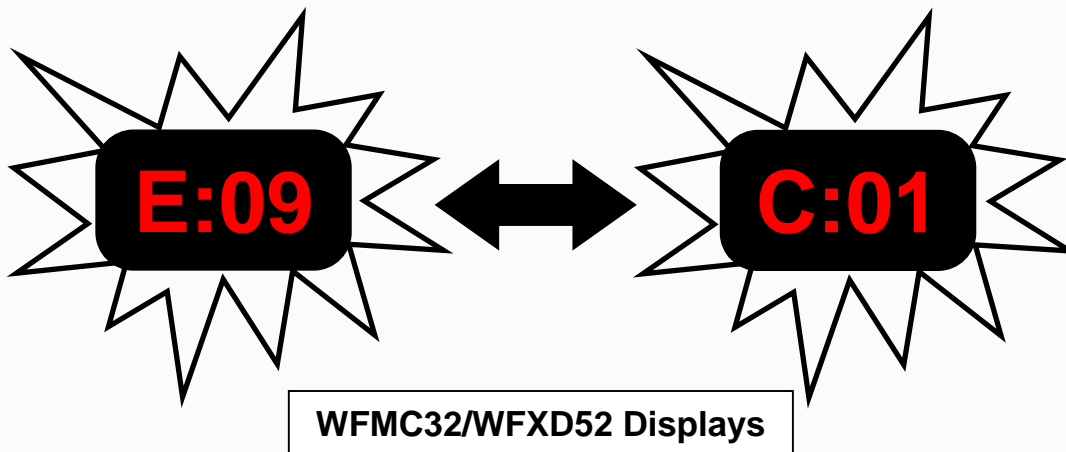

WFMC32/WFXD52 fault code displays flash – alternating between fault code (**E:09**) and wash when fault occurred (**C:01**)

TIP: Washers are designed to give a service history, not show only latest fault codes. Since fault codes stored in module or motor control can't be cleared, don't expect fault codes to be reset to "0" when repairs are made.



WFMC64/WFXD84 Displays

WFMC64/WFXD84 displays show fault code (**Er:09**) and wash when fault occurred (**1**)

NOTE: Some control modules have been replaced since fault codes stored in module or motor control can't be cleared. Modules are operating properly and shouldn't be replaced to clear fault codes.

WFMC/WFXD Service Tips – Test Program (2B): Module Fault Codes (Test 1)

Test P1:ERRORS / P:01 (Viewing control module fault codes) -- Start & end test P1 (WFMC64/WFXD84) / (P:01) (WFMC32/WFXD52) by pushing **Start/Pause** button. Scroll through list of fault codes by pushing **Spin Selection** (WFMC32/WFXD52) or **Menu** (WFMC64/WFXD84) buttons.

- WFMC32/WFXD52 displays alternate between fault code (e.g. **E:01**) & when fault occurred on in last 8 washes (e.g. **C:00**) – shows **C:00** if fault didn't occur.
- WFMC64/WFXD84 displays show fault code & when fault occurred on in last 8 washes (e.g. **0 - Er:01**).

Last 8 fault codes are stored & displayed!

HINT: # of faults reads "0" for faults which didn't occur. Look at # of faults, not error #, to see if faults occurred -- scroll thru all faults to check if any occurred.

WFMC32/WFXD52 Displays	WFMC64/WFXD84 Displays	Test #	Problem	Possible Cause(s)
E:01	Er:01	washing	Door open	Door lock not engaged
E:02	Er:02	washing	Door lock doesn't unlock	Jammed lock or bad wire harness
E:03	Er:03	washing	Door lock doesn't lock	Jammed lock or bad wire harness
E:04	Er:04	washing	Door control broken	Faulty Triac or control module
E:05	Er:05	P:16	NTC open-circuited	Faulty NTC or bad wire harness
E:06	Er:06	P:16	NTC shorted	Faulty NTC or bad wire harness
E:07	Er:07	P:16	Unexpected heating (heater on at wrong time)	Faulty heater or stuck heater relay
E:08	Er:08	P:16	Heater doesn't shut off	Faulty heater or stuck heater relay
E:09	Er:09	P:4	Communication lost to motor	Faulty wire harness
----	Er:10	P:11	Flow meter gives wrong values	Faulty flow meter or wire harness
----	Er:11	P:8/9/13	No water flow (within 6 minutes)	Faulty inlet valve, wire harness, hose
E:12	Er:12	P:8/9/13	Water supply time exceeded	Faulty inlet valve, wire harness, hose
E:13	Er:13	P:15	Drain pump time exceeded	Faulty drain pump, wire harness, hose
E:14	Er:14	P:9	Overflow level exceeded	Faulty/blocked pump, hose, inlet valve
----	Er:15	P:8	Pressure sensor gives failure voltage level	Faulty pressure sensor, wire harness
----	Er:16	P:8	Can't calibrate pressure sensor	Faulty pressure sensor, wire harness
E:20	Er:20	P:4	Spinning aborted due to unbalanced load	Unbalanced load or faulty wire harness
E:21	Er:21		Excessive foam	Wrong or too much detergent used
E:22	Er:22	washing	Frequency synchronization failed	Faulty control module
E:24	Er:24	P:4	Motor power relay failed	Faulty control module

WFMC/WFXD Service Tips – Test Program (2C): Motor Control Fault Codes (Test 1)

Test **P1:ERRORS / P:01** (Viewing motor control fault codes) -- Start & end test **P1** by pushing **Start/Pause** button. Scroll through list of (18) fault codes by pushing **Spin Selection** (WFMC32/WFXD52) or **Menu** (WFMC64/WFXD84) buttons.

- WFMC32/WFXD52 displays alternates between fault code (e.g. **d:01**) & when fault occurred on in last 16 washes (e.g. **C:00**) – shows **C:00** if fault didn't occur.
- WFMC64/WFXD84 displays shows fault code & when fault occurred on in last 16 washes (e.g. **0** - **dr:01**).

Last 16 fault codes are stored & displayed!

HINT: # of faults reads "0" for faults which didn't occur. Look at # of faults, not error #, to see if faults occurred -- scroll thru all faults to check if any occurred.

WFMC32/WFXD52 <i>Displays</i>	WFMC64/WFXD84 <i>Displays</i>	<i>Test #</i>	<i>Problem</i>	<i>Possible Cause(s)</i>
d:01	dr:01	P:04	Motor control short circuited.	Faulty motor control.
d:02	dr:02	P:04	Motor control interruption.	Faulty motor control.
d:03	dr:03	P:04	Damaged motor control temperature sensor.	Faulty temperature sensor.
d:06	dr:06	P:04	Motor control NTC relay failure.	NTC too hot or relay stuck closed.
d:07	dr:07	P:04	Motor control (inverter) failed or motor shorted.	Faulty motor control or motor.
d:08	dr:08	P:04	Motor speed sensor failed.	Faulty speed sensor or wire harness.
d:09	dr:09	P:04	Voltage too high.	Faulty motor control.
d:10	dr:10	P:04	Power limiter switch off.	Motor overloaded or binding.
d:11	dr:11	P:04	Voltage too low.	Faulty motor control.
d:12	dr:12	P:04	Motor control high current switch off.	Motor overloaded or binding.
d:13	dr:13	P:04	Motor control high temperature switch off.	Motor overloaded or binding.
d:14	dr:14	P:04	Motor control high temperature warning.	Motor overloaded or binding.
d:15	dr:15	P:04	Power limiter warning.	Motor overloaded or binding.
d:16	dr:16	P:04	Motor high temperature switch off.	Motor overloaded or binding.
d:17	dr:17	P:04	Motor high temperature warning.	Motor overloaded or binding.
d:18	dr:18	P:04	Peak voltage too high.	Faulty motor control.

WFMC/WFXD Service Tips – Test Program (3): Tests 2 & 3

Test P2:SAFETY / P:02 (Safety test program) --

Skip this European test. Test ends on its own - stop it by pushing the **Spin Selection** button (WFMC32/WFXD52) or **Menu** button (WFMC64/WFXD84).

Operation	WFMC64/WFXD84 Display	Notes
Starts filling (valve 2 - cold)	D M P H V 1 2 3 N _H n 075	HINT: Do not use this test as it applies to European models requiring VDE safety testing.
Starts heating (30 seconds)	D M P H V 1 2 3 N _H n 075	

NOTE: "n" = pressure switch (analog sensor) reading.

Test P3:AUTOM / P:03 (Automatic test program) --

Test 3 turns on motor (wash & spin), heater, drain pump and water valves separately for a visual check. No fault codes are generated.

Test 3 ends on its own - stop it by pushing the **Spin Selection** button (WFMC32/WFXD52) or **Menu** button (WFMC64/WFXD84).

Operation	WFMC64/WFXD84 Display	Notes
Starts filling (valve 2 - cold)	D M P H V 1 2 3 N ₀ t23 0000	Water starts at N ₀ level (no water)
Fills up to N _H level	D M P H V 1 2 3 N _H t23 0000	Filling using valve 2 - cold
Starts heating	D M P H V 1 2 3 N _H t23 0000	Stops valve 2 filling
Starts 2nd fill (valves 1 & 2 - cold)	D M P H V 1 2 3 N _H t23 0000	Keeps heating

Operation	WFMC64/WFXD84 Display	Notes
Starts ccw rotation	D M P H V 1 2 3 N _H t23 0051	Filling valve 1 only
Starts cw rotation	D M P H V 1 2 3 N _H t23 0051	Filling valve 1 only
Starts 3rd fill (valve 3 - hot)	D M P H V 1 2 3 N _H t23 0000	Stops rotation
Starts draining	D M P H V 1 2 3 N _H t23 0000	
Drum starts spinning	D M P H V 1 2 3 N ₀ t23 0072	Rotation ccw. Water level reaches N ₀ .
Drum spins at full speed (~ 1200 RPM)	D M P H V 1 2 3 N ₀ t23 1154	Doesn't have to hit 1200 RPM exactly
Drum slows down	D M P H V 1 2 3 N ₀ t23 0066	
Test stops	D M P H V 1 2 3 N ₀ t23 0000	

NOTE: "t" = temperature measured on NTC (can vary).

NOTE: "⊙" = actual drum speed (RPM)

NOTE: WFMC32/WFXD52 displays don't show any change during test – it stays on **P:03**. Only light lit is **Door locked** light.

WFMC/WXFD Service Tips – Test Program (4): Tests 4 & 5

Test **P4:MOTOR / P:04** (Motor test program) --

Test 4 turns on motor (wash & spin) and generates fault codes.

The test takes > 10 minutes to run and ends on its own, but can be stopped by pushing the **Spin Selection** button (WFMC32/WFXD52) or **Menu** button (WFMC64/WFXD84).

Operation	WFMC64/WFXD84 Display	Notes
Runs 6 seconds ccw		Checks wash speed (50 RPM)
Stops and pauses for 2 seconds		
Runs 4 seconds cw		Checks wash speed (50 RPM)
Stops and pauses for 2 seconds		
Spins to full speed -- 1200 RPM (WFMC64/ WFXD84) or 1000 RPM (WFMC32/WFXD52)		Checks spin speed -- stops @ 100 RPM if load unbalanced.

HINT: If motor fault codes are generated, check both motor control and motor for problems.

- Check motor control output voltage (~ 120 VAC, 3-phase, 0 - 400 Hz). Control output can be 90 – 190 VAC.
- Check motor resistances.

Test **P5:VARIANT / P:05** (Model coding)

Skip test 5. Both factory & replacement control modules are preprogrammed and cannot be changed. So, there's no way to change the module configurations.

- WFMC32/WFXD52 displays show 0:7 & 1:0 as test P5 is scrolled through.
- WFMC64/WFXD84 displays show 0:7, 1:0 & 2:0 as test P5 is scrolled through.

HINT: If **Start/Pause** light doesn't come on for some tests, door is open. Turn off washer, then close door.

HINT: Start/Pause button light:

- Flashes **red** when tests can be selected or scrolled through.
- Stays **red** continually (or stays off) when tests are running.
- Doesn't come on for some tests if door is open.

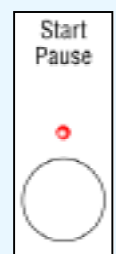





WFMC/WFXD Service Tips – Test Pgm (5): Tests 6 & 7

Test P6:DISPLAY / P:06 (Display test program) --

Test 6 turns on all displays for a visual check. The test ends on its own (in ~ 50 seconds for WFMC64/WFXD84) - stop it by pushing the **Spin Selection** button (WFMC32/WFXD52) or **Menu** button (WFMC64/WFXD84).

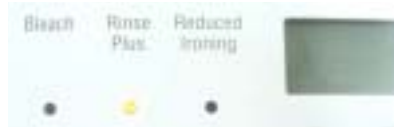
No fault codes are generated. If a display segment doesn't come on, replace control module (since displays are included with control modules).



NOTE: On WFMC32/WFXD52 models, all lights come on (in sequence) -- all display #'s come on, then all display segments come on.

WFMC64/WFXD84 Display	Notes
	While WFMC64/WFXD84 lights flash, the display is blank.
	All upper (half of) display pixels are turned on at once.
	All lower (half of) display symbols are turned on at once.
	All lower (half of) display symbols are turned on individually (one at a time).
	The red background of the display flashes on and off 5 times.

Test P7:SELECTOR / P:07 (Selector knob test program) --

Test 7 turns on the selector knob for a visual check. No fault codes are generated.

Rotate knob ccw through all positions -- don't rotate through **Off** position or test program will end. Stop test 7 by pushing the **Spin Selection** button (WFMC32/WFXD52) or **Menu** button (WFMC64/WFXD84).

Operation	WFMC64/WFXD84 Display	Notes
Rotating selector knob	P7:SELECTOR P11	For WFMC64/WFXD84, display shows P17 - P01 for <i>Permanent Press Cold - Regular/Cotton Cold</i> (rotating ccw through each knob position).
Select button (WFMC64/WFXD84)	P7:SELECTOR 	
Menu button (WFMC64/WFXD84)	P7:SELECTOR 	
Spin Selection button (WFMC32/WFXD52)		<i>No final spin</i> light stays on while button is held.
Delay Start button (WFMC32/WFXD52)		<i>Rinse</i> light stays on while button is held.
Other buttons (<i>Bleach, Rinse Plus, Power Wash (WFMC32), Reduced Ironing (WFMC64/WFXD84)</i>)		Light above each button will light up while button is held.

NOTE 1) For WFMC32/WFXD52, display shows L:15 - L: 1 for *Permanent Press Cold - Regular/Cotton Cold* (rotating ccw through each knob position).

NOTE 2) If a display segment doesn't come on, replace control module (since button & knob switches are included with control modules).

WFMC/WFXD Service Tips – Test Pgm (6): Tests 8 & 9

Test P8:NIVEAU1 (Analog pressure switch test program) -- The test turns on the analog pressure switch (WFMC64/WFXD84 only) and generates fault codes. The test can be stopped by pushing the **Menu** button.

Operation	WFMC64/WFXD84 Display	Notes
Changes as water level changes	D M P H V 1 2 3 N ₀ 100 n000	
Calibrates analog sensor		
Changes as water level changes	D M P H V 1 2 3 N _H 165 n075	
Pauses for 10 seconds		
Changes as water level changes	D M P H V 1 2 3 N _D 165 n139	

Offset of analog pressure switch

Value of analog pressure switch

Test P9:NIVEAU2 / P:09 (Mechanical pressure switch test program) -- The test turns on the mechanical pressure switch and generates fault codes. Stop it by pushing the **Spin Selection** button (WFMC32/WFXD52) or **Menu** button (WFMC64/WFXD84).

Operation	WFMC64/WFXD84 Display	Notes
Changes as water level changes	D M P H V 1 2 3 N ₀ U00 n000	
Changes as water level changes	D M P H V 1 2 3 N _H U03 n075	
	D M P H V 1 2 3 N _H U15 n075	When n075 has been reached, volume display jumps to U15.

Water volume measured by flow meter

Value of mechanical pressure switch

HINT: If **Start/Pause** light doesn't come on for some tests, door is open. Turn off washer, then close door.

HINT: Water level symbols change as follows:

- **WFMC64/WFXD84** -- from **N₀** (below heating level) to **N_H** (heating level) to **N_D** (door locked level).
- **WFMC32/WFXD52** -- from **63** (below heating level) to **88** (heating level) to **177** (door locked level).

WFMC/WFXD Service Tips – Test Pgm (7): Tests 11 - 13

Test P11:FLOW (Flow meter test program) -- The test turns on the flow meter (WFMC64/WFXD84 only) and generates fault codes. The test has ended when **U05** has displayed (< 1 minute) and can be stopped by pushing the **Menu** button.

Operation	WFMC64/WFXD84 Display	Notes
Changes as water level changes	D M P H V 1 2 3 N ₀ U00 F...	Run test P1 to check fault code -- if Er:13, check water inlet valve.
Changes as water level changes	D M P H V 1 2 3 N ₀ U05 F...	Run test P1 to check fault code -- if Er:12, check flow meter for errors.

Water volume measured by flow meter

Flow rate measured by flow meter in liters/minute

Test P12: UPDATE / P:12 (Update programming) --

This test cannot be used presently. If selected, it can only be exited by turning the washer off using the selector knob.

HINT: Water level symbols change as follows (e.g. test P13):

- **WFMC64/WFXD84** -- from **N₀** (below heating level) to **N_H** (heating level) to **N_D** (door locked level).
- **WFMC32/WFXD52** -- from **63** (below heating level) to **88** (heating level) to **177** (door locked level).

HINT: If **Start/Pause** light doesn't come on for some tests, door is open. Turn off washer, then close door.

Test P13:VALVE1 / P:13 (Water inlet valves test program) -- The test turns on all 3 water inlet valves and generates fault codes.

It stops when n20 level is reached (max. 10 minutes). Stop it by pushing the **Spin Selection** button (WFMC32/WFXD52) or **Menu** button (WFMC64/WFXD84).

Operation	WFMC64/WFXD84 Display	Notes
Test runs valves in sequence: 1, 2, 1 + 2 & 3.	D M P H V 1 2 3 N _D U22 n253	Analog pressure sensor reading increases after valves shut off.

Flow rate measured by flow meter in liters/minute

Value of analog pressure switch

HINT: On WFMC32/WFXD52, each valve is checked automatically. On WFMC64/WFXD84, push **Start/Pause** button to check each valve:

- At start of test, valve 1 (cold) is tested.
- Push **Start/Pause** button again to check valve 2 (cold).
- Push **Start/Pause** button again to check valves 1 + 2 (dual cold).
- Push **Start/Pause** button again to check valve 3 (hot).
- Pushing **Start/Pause** button again checks valve 1 again.
- Push **Menu** button to exit test.

NOTE: On WFMC32/WFXD52, displays alternates from "P:13" to "63", "88" or "177", depending on water level (below or at heating level).

HINT: Test runs until max. water level reached or is stopped by pressing **Menu** button. To save time with Test P13, press **Menu** to stop test when all valves have been checked. Run Test P15 to drain washer if needed.

WFMC/WFXD Service Tips – Test Pgm (8): Tests 14 - 17

Test P14:BUZZER / P:14 (Buzzer test program) --
Buzzer sounds when test is run.

Test P15:PUMP / P:15 (Drain pump test program) -
- The test turns on the drain pump and generates fault codes. The test runs for ~ 30 minutes and can be stopped by pushing the **Spin Selection** button (WFMC32/WFXD52) or **Menu** button (WFMC64/WFXD84).

Operation	WFMC64/WFXD84 Display	Notes
Filling (to door locked level) and draining		Can save time by filling & then running <i>Drain</i> cycle to check for water draining.

Value of analog pressure switch

HINT: Water level symbols change as follows (e.g. test P15):

- **WFMC64/WFXD84** -- from **N₀** (below heating level) to **N_H** (heating level) to **N_D** (door locked level).
- **WFMC32/WFXD52** -- from **63** (below heating level) to **88** (heating level) to **177** (door locked level).

HINT: **Start/Pause** button light:

- Flashes **red** when tests can be selected or scrolled through.
- Stays **red** continually (or stays off) when tests are running.
- Doesn't come on for some tests if door is open.

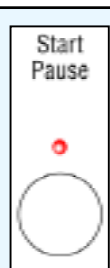

Test P16:HEATER / P:16 (Heater & NTC test program) -- The test turns on the heater & NTC and generates fault codes. The test runs for ~ 30 minutes and can be stopped by pushing the **Spin Selection** button (WFMC32/WFXD52) or **Menu** button (WFMC64/WFXD84).

Operation	WFMC64/WFXD84 Display	Notes
Changes as water level changes		
		During heating, temperature display rises to t86 max. (86°C/187°F)

Water temperature in °C

HINT: To save time with Test T16, press **Menu** to stop testing after the temperature has gone up several degrees, confirming the washer is heating OK.

NOTE: On Test T16, the water level rises until **N_H**, which is the heating water level.

P17:NOISE / P:17 (Factory noise test program) --
Not relevant to customer service – do not use. This test is similar to automatic test P3, except no heating is done and nothing is shown on displays. This test merely turns on certain parts so the factory can measure noise.

WFMC/WFXD Service Tips – Troubleshooting (1)

<i>Symptom</i>	<i>Problem</i>	<i>Solution</i>
Washer won't start.	<ul style="list-style-type: none"> ❑ Electricity is disconnected or has been turned off. ❑ Cycle selector knob or control module has failed. 	<ul style="list-style-type: none"> ❑ Make sure washer is connected to an appropriate 120V, 60 Hz circuit (according to local codes). Turn on electricity. ❑ Control module has onboard cycle selector knob. Check voltage output to water inlet valves and drum motor (when they're energized). If no voltage, replace faulty control module.
Washer won't fill.	<ul style="list-style-type: none"> ❑ Water supply turned off. ❑ Water inlet hose filters (strainers) blocked. ❑ Water pressure too low. ❑ Control module has failed. ❑ Water inlet valve(s) has failed. 	<ul style="list-style-type: none"> ❑ Turn on water supply. ❑ Check water inlet hose filters. Clean if dirty. Replace filters if damaged. ❑ Check incoming water pressure. ❑ Check voltage output to water inlet valves (when they're energized). If no voltage, replace faulty control module. ❑ Measure resistance of water inlet valves (~ 2.7 – 4.5 kΩ). Replace inlet valve(s), if faulty.
Washer won't drain.	<ul style="list-style-type: none"> ❑ Drain pump or pump motor protector has failed. ❑ Control module has failed. 	<ul style="list-style-type: none"> ❑ Disconnect drain pump and measure resistance at connector (~ 140 – 200 Ω). Replace drain pump if faulty. ❑ Check voltage output to drain pump when it's energized. If no voltage, replace faulty control module.

WARNING! Unplug washer before starting any repairs.

HINT: The washer test program diagnoses problems quickly and thoroughly where resistance measurements usually aren't needed.

WFMC/WFXD Service Tips – Troubleshooting (2)

<i>Symptom</i>	<i>Problem</i>	<i>Solution</i>
Drum won't rotate.	<ul style="list-style-type: none"> <input type="checkbox"/> Drum rear bearing has failed. <input type="checkbox"/> Motor control has failed. <input type="checkbox"/> Drum drive motor has failed. 	<ul style="list-style-type: none"> <input type="checkbox"/> Check how drum rotates. If drum wobbles or won't move, replace outer tub (containing faulty rear bearings). <input type="checkbox"/> ① Check voltage at motor connectors when motor is energized. If low or no voltage, replace faulty motor control. ② If voltage ~ 120V, check motor resistance (when washer de-energized). If motor is OK, replace faulty motor control. <input type="checkbox"/> Check voltage at motor connectors when motor is energized. If ~ 120V, check motor resistance (when washer de-energized). If motor faulty, replace faulty drum motor.
Washer won't heat.	<ul style="list-style-type: none"> <input type="checkbox"/> Heater has failed. <input type="checkbox"/> NTC has failed. <input type="checkbox"/> Heater is covered with scale. <input type="checkbox"/> Voltage too low. <input type="checkbox"/> Control module has failed. 	<ul style="list-style-type: none"> <input type="checkbox"/> Disconnect heater and measure resistance at terminals (~ 13.7 – 15.2 Ω). Replace heater if faulty. <input type="checkbox"/> Disconnect NTC and measure resistance at terminals (~ 22.8 – 27.4 k Ω @ 20°C (68°F)). Replace NTC if faulty. <input type="checkbox"/> If possible, remove & clean heater. If not, replace it. <input type="checkbox"/> Have an electrician check the house wiring and the wiring to the washer to make sure it is 120 volts. <input type="checkbox"/> Check voltage output to drain pump when it's energized. If no voltage, replace faulty control module.

WARNING! Unplug washer before starting any repairs.

HINT: The washer test program diagnoses problems quickly and thoroughly where resistance measurements usually aren't needed.

WFMC/WFXD Service Tips – Troubleshooting (3)

<i>Symptom</i>	<i>Problem</i>	<i>Solution</i>
Washer overheats.	<ul style="list-style-type: none"> ❑ Control module has failed. ❑ NTC failed. 	<ul style="list-style-type: none"> ❑ Check voltage to heater. If voltage is present when heater shouldn't be on, replace faulty control module. ❑ Disconnect NTC and measure resistance at terminals (~ 22.8 – 27.4 kΩ @ 20°C (68°F)). Replace NTC if faulty.
Door won't lock.	<ul style="list-style-type: none"> ❑ Door isn't closed properly. ❑ Door latch is broken. ❑ Door lock has failed. 	<ul style="list-style-type: none"> ❑ Close door securely. If door won't latch, check door latch and door hinge alignment. ❑ Replace broken door latch. ❑ Measure resistance of door lock mechanism (~ 159 - 211 Ω). Replace faulty door lock mechanism.

WARNING! Unplug washer before starting any repairs.

HINT: The washer test program diagnoses problems quickly and thoroughly where resistance measurements usually aren't needed.



WFMC/WFXD Service Tips – Troubleshooting of Minor Faults 1 (Customer Self-Help)

Troubleshooting of Minor Faults

⚠ DANGER ⚠

RISK OF ELECTRIC SHOCK!

Repairs should only be carried out by an authorized technician.

If repairs are necessary, and you cannot eliminate the fault yourself with the aid of the following table:

- Turn the program selector to **Off**.
- Disconnect the washing machine from the power outlet.
- Turn off the water tap.
- Call Customer Service (refer to Page 35).

Fault	Possible cause	Action
The door cannot be opened.	"No final spin" selected.	Select Drain or Spin .
	Child lock activated.	Deactivate child lock; see Page 26
	Power failure.	An interrupted program will be resumed when power is restored. If the laundry is to be removed during a power failure, call Customer Service (refer to Page 35).
	Program is running and/or the door is locked for safety reasons.	Wait until the program ends; see Page 29.
Door cannot be opened, even though the appliance has been switched off and on again.	Plug is loose or not inserted.	Eliminate the cause.
	Program selector turned to Off before end of program.	Select a program.
	Child lock activated.	Deactivate child lock; see Page 26.
Door cannot be opened, even though the appliance has been switched off and on again.	For safety reasons the door has been locked because the water level, temperature or drum speed is too high.	See "Adding to the laundry/interrupting the program", Page 28.
Program continues running, even though the appliance has been switched off and on again.	Child lock activated.	Deactivate child lock; see Page 26.
Appliance cannot be operated. "Child lock activated" as indicated in the display field.	Child lock activated.	Deactivate child lock; see Page 26.

Fault	Possible cause	Action
Control lights do not light up.	A fuse has blown.	Replace the fuse of the individual circuit. Call Customer Service if this fault recurs.
	Power failure.	An interrupted program will be resumed when power is restored. If the laundry is to be removed during a power failure, call Customer Service (refer to Page 35).
	Appliance is in energy-saving mode. This is not a fault.	Press the Select button; energy-saving mode is terminated.
Program does not start. Start/Pause indicator light flashes.	Start/Pause button not pressed.	Press the Start/Pause button.
Program does not start. "Check Door!" indicated in the display field.	door not closed properly.	Check whether laundry is trapped in door. Close the door (a click should be heard). Program continues.
"Press start" is indicated in the display field.	End time selected but still not activated by pressing the Start/Pause button.	Press the Start/Pause button.
Program does not start. "Real Time delay" is indicated in the display field.	End time selected and activated.	None. Appliance starts automatically.
Clock cannot be set.	Program has already started; when a program has started, the clock cannot be set.	Wait until program ends.
"Set clock" text remains in the display field even though the Menu button has been pressed.	The setting has switched from hours to minutes; both selection points have the same text.	None.
No time displayed.	Time not set.	Set time; see Page 27.
End time cannot be selected.	Time not set.	Set time; see Page 27.
	Program has already started; when a program has started, the end time can no longer be selected.	Before starting the program, select and start the desired end time; see Page 24.
Spin speed cannot be selected.	Spinning is already in progress; during spin cycle the speed cannot be changed.	Select speed before spinning.
	Program selector is set to Drain ; spin cycle is not possible with this program.	If required, select another program.
Child lock cannot be selected.	The program has already started.	Child lock can be selected in pause mode.
Detergent residue in the detergent dispenser.	Detergent was damp or lumpy.	Clean and dry the detergent dispenser; see Page 30. Use the cap of the detergent bottle to measure liquid detergents.
Water does not enter the machine or detergent is not washed away. "Water tap closed?" indicated in the display field.	Water tap not turned on.	Turn on water tap. Program continues.
	Supply hose kinked or pinched.	Eliminate the cause.
	Strainers in supply hose clogged.	Clean the water inlet strainers; see Page 30.
Water cannot be seen in drum.	Water pressure too low.	Eliminate the cause.
	This is not a fault. The water level is below the visible part of the drum.	

WFMC/WFXD Service Tips – Troubleshooting of Minor Faults 2 (Customer Self-Help)

Fault	Possible cause	Action
Washing solution has not drained completely. "Drainage blocked?" indicated in the display field.	The water drainage pipe and/or drain hose is blocked.	Clean the water drainage pipe and/or drain hose.
Water is flowing out from underneath the machine.	The thread of the supply hose is not tight. Leak in the drain hose.	Tighten the thread. Replace the drain hose.
Suds coming out of the detergent dispenser.	Too much detergent.	Mix 1 tablespoon of fabric softener with 1 pt (½ litre) of water and pour into detergent dispenser 1. Reduce the amount of detergent next time, use a low sudsing detergent.
Repeated spinning.	This is not a fault. The imbalance compensation system is attempting to balance the load through repeated spins.	Always load the drum with large and small items together.
The laundry was not spun.	Large items of clothing have become entangled and could not be distributed evenly in the drum. For reasons of safety the high-speed spin cycle was automatically suppressed.	Always load the drum with large and small items together.
Program duration extended.	This is not a fault. The suds detection feature has activated an additional rinsing cycle to reduce the amount of suds. This is not a fault. The imbalance compensation system is attempting to balance the load through repeated spins.	Add a more appropriate amount of detergent. Always load the drum with large and small items together.
Unsatisfactory washing result.	The degree of soiling was higher than estimated. Not enough detergent.	Select suitable program or Power Wash as an additional option. Add detergent according to the manufacturer's specifications.
Detergent residues on the laundry.	Some phosphate-free detergents contain water-insoluble residues that may appear as light spots on the laundry.	Brush off spots when laundry is dry.
Gray residue on the laundry.	Dirt accumulation from ornaments, lats or oils.	Add the maximum amount of detergent and select the highest permissible temperature.

Fault displays

Text in display field	Possible cause	Action
"Water tap closed?"	Water tap not turned on.	Turn on water tap. Program continues.
	Supply hose kinked or trapped.	Eliminate the cause.
	Strainer in supply hose clogged.	Clean the water inlet strainers; see Page 30.
	Water pressure too low.	Eliminate the cause.
"Drainage blocked?"	The water drainage pipe and/or drain hose is blocked.	Clean the water drainage pipe and/or drain hose.
"Check Door!"	door not closed properly.	Check whether laundry is trapped in door. Close the door.

If the fault cannot be eliminated with the aid of the above table, switch the appliance off, wait 5 seconds, switch the appliance on again, select and start the program.

WFMC/WFXD Service Tips – Customer Cleaning & Maintenance

User Maintenance Instructions

Cleaning and Care



RISK OF ELECTRIC SHOCK!

Always disconnect the appliance from the power outlet before cleaning.

Never clean the washing machine with a pressure washer.



RISK OF EXPLOSION!

Never use flammable solvents to clean the appliance.

Cleaning the appliance housing and control panel

As required:

- ❑ Use hot soapy water or a mild, non-abrasive cleaning agent.
- ❑ Rub dry with a soft towel.

Cleaning the drum

If rust spots have formed due to left-over debris (e.g. coins, paper clips, nails):

- ❑ Use a chlorine-free cleaning agent. Follow the manufacturer's instructions. Never use steel wool.

Cleaning the detergent dispenser

If residual detergents or additives have accumulated or if softener/bleach are not fully rinsed out:

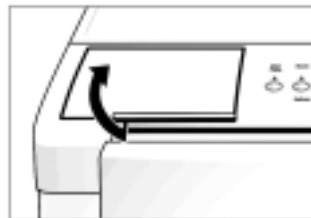

- ❑ Open the flap of the detergent dispenser.



- ❑ Pull out the softener/bleach compartment in a vertical direction and remove.
- ❑ Clean the detergent dispenser insert under running water. This can be disassembled into two parts!



- ❑ Insert the detergent dispenser until it clicks into place.

Cleaning water inlet strainers

This is necessary if very little or no water flows into the washing machine.

First release the water pressure in the supply hoses:

- ❑ Turn off the water taps.
- ❑ Turn the program selector to any program (except **Spin** or **Drain**).
- ❑ Press **Start/Pause** button and wait for "Water tap closed?" message.
- ❑ Turn the program selector to **Off**.

Cleaning the strainer(s) on the water tap

On both the hot and cold water tap:

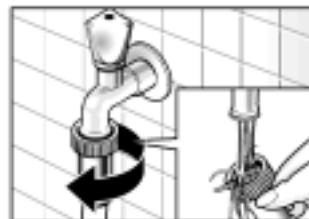

- ❑ Disconnect the hose from the water tap.
- ❑ Rinse the strainer under flowing water.
- ❑ Reconnect the hose.

Cleaning the strainers on the washing machine

On both the hot and cold water tap:

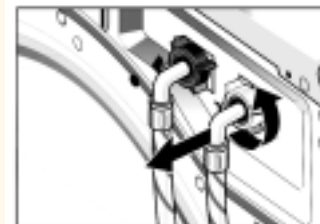

- ❑ Disconnect the hose from the back of the washing machine.

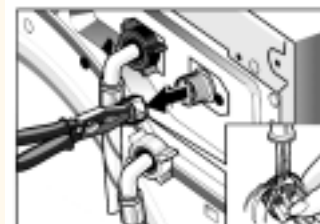

- ❑ Pull out the strainer and rinse under running water.
- ❑ Insert the strainer and reconnect the hose.
- ❑ Turn on the water taps and check that there are no leaks. If water is leaking, check that the strainer is properly attached.
- ❑ Turn off the water taps.

Descaling the washing machine



Descaling agents contain acids which may attack parts of the washing machine and discolor the laundry.

Provided that you use the correct type of detergent, it is not necessary to descale the washing machine.

If white spots, lime or mineral deposits appear on the interior of the washing machine drum you can use a descaling agent to remove them.

However, if the appliance has to be descaled, please follow the instructions provided by the descaling agent manufacturer.

WFMC/WFXD Service Tips – Oversudsing & Suds Lock

If washers time out and shut off without an end of cycle signal (and without going through the spin cycle), the washer has experienced **suds lock**, a possible occurrence with all front loader washers (regardless of manufacturer).

- **Suds lock:** *Suds lock* comes from suds (airy foam) interfering with water level sensors (pressure switches). Electronic controls are fooled into thinking water hasn't been removed fully, so washers won't go into spin cycles. Drain pumps can also get air locks in them.
- **Cause:** *Suds lock & oversudsing* come from using too much detergent, using the wrong kind of detergent (not HE) or overloading washers (trapping suds in clothes).
- **Solution:** Where *oversudsing* has occurred, have the washer cleaned out every 6 months by running it without clothing using a hot water wash (with cold water rinse) & ½ gallon of white vinegar. When suds have overflowed, run a cold water rinse using 1 gallon of white vinegar. **NOTE:** Don't use vinegar routinely to avoid possible damage to washer parts.
- **Customer education:** Educate customer on type (HE) and amount of detergent to use. To remove suds from clothes, have customer rewash clothes with liquid fabric softener, ½ recommended amount of detergent & a cold water rinse.



TIP: Because front loader washers wash the same amount of clothes more efficiently and with much less water than top loader washers, high efficiency (HE) detergent specially formulated for front loader washers is needed. Have customers follow detergent directions and not expect to see suds.

TIP: Powdered detergent works better than liquid detergents (due to more surfactants in liquid detergents).

NOTE: Where possible, handle such calls over the phone without making service calls.