

All About

Servicing

Affinity Front Load
6000 & 7000 Series

3.5 Cu. Ft. Washers

FRIGIDAIRE™

W White-Westinghouse

Gibson

Kelvinator 

TAPPAN

Electrolux Major Appliances; North America
250 Bobby Jones Expwy
Augusta, GA 30907

Safe Servicing Practices

Avoid personal injury and/or property damage by observing important Safe Servicing Practices.

Following are some limited examples of safe practices:

1. DO NOT attempt a product repair if you have any doubts as to your ability to complete the repair in a safe and satisfactory manner.
2. Always Use The Correct Replacement Parts as indicated in the parts documentation. Substitutions may defeat compliance with Safety Standards Set For Home Appliances.
3. Before servicing or moving an appliance:
 - Remove power cord from the electrical outlet, trip circuit breaker to OFF position, or remove fuse.
 - Turn off water supply.
4. Never interfere with the proper operation of any safety device.
5. Use ONLY REPLACEMENT PARTS CATALOGED FOR THIS APPLIANCE. Substitutions may defeat compliance with Safety Standards Set For Home Appliances.
6. GROUNDING: The standard color coding for safety ground wires is GREEN, or GREEN with YELLOW STRIPES. Ground leads are not to be used as current carrying conductors. It is EXTREMELY important that the service technician reestablish all safety grounds prior to completion of service. Failure to do so will create a hazard.
7. Prior to returning the product to service, ensure that:
 - All electrical connections are correct and secure.
 - All electrical leads are properly dressed and secured away from sharp edges, high temperature components, and moving parts.
 - All non-insulated electrical terminals, connectors, heaters, etc. are adequately spaced away from all metal parts and panels.
 - All safety grounds (both internal and external) are correctly and securely connected.
 - All panels are properly and securely reassembled.
 - Electrical and water supplies are turned ON if shut off prior to service.

ATTENTION!!!

This service manual is intended for use by persons having electrical and mechanical training and a level of knowledge of these subjects generally considered acceptable in the appliance repair trade. Electrolux Home Products, Inc. cannot be responsible, nor assume any liability, for injury or damage of any kind arising from the use of this manual.

© 2009 Electrolux Home Products, Inc.

Section 1 Basic Information

Table of Contents

Section 1 Basic Information

Safe Servicing Practices	1-1
Table of Contents	1-2
Warnings and Cautions	1-3
Safety Instructions	1-3
Protect Children	1-4
Prevent Fire	1-4
Serial / Model Number Breakdown	1-5
Drum Water Height	1-5
Water Usages	1-5
Motor Wattage	1-5
Component Resistance Chart	1-5
Washer Component Operation	1-6
Control	1-6
Drum Light Assembly	1-6
Door Switch Assembly	1-6
Door Lock Assembly	1-6
Pressure Switch	1-7
Electronic Water Level Sensor	1-8
Water Inlet Valve Assembly	1-8
Water Valve Operation	1-8
Water Temperature	1-10
Auto Temp System	1-10
Automatic Dispenser	1-11
Drain Pump	1-14
Motor	1-15
Speed Control	1-15
Tub Construction	1-15
Warranty Information	1-16

Section 2 Installation Information

Warnings	2-1
Pre-Installation Requirements	2-2
Electrical System Requirements	2-2
Grounding Requirements	2-2
Unit Dimensions	2-3
Water Supply Requirements	2-4
Drain System Requirements	2-4
Unpacking Unit	2-4
Clearance Requirements	
Installation in a Recess or Closet	2-5
Leveling Washer	2-6
Connecting Inlet Water	2-6
Connecting Drain and Electrical	2-7
Installation Checklist	2-7
Washer and Dryer 15" Drawer Pedestal Installation	2-8

Section 3 Electronic Control

Affinity 6000 & 7000 Series Control Panel Layout...	3-1
Operating Steps	3-2
Cycle Selection	3-2
Cycle Description	3-2
Cycle Settings	3-3
Cycle Options	3-4
Washer Features	3-4
Affinity 6000 Series Cycle Chart	3-5
Affinity 7000 Series Cycle Chart	3-6
Troubleshooting Error Codes	3-7
Reading Error Codes	3-7
Quick Check	3-7
To Clear Latest Stored Error Code	3-7
Diagnostic Test	3-8
Exiting Diagnostic Mode	3-8
Drum Light Circuit Testing	3-8
Failure Code Chart	3-9
Tests 1-5	3-11
Tests 6-16	3-12
Jacks and Plugs	3-13
Operation Speed Chart	3-14

Section 4 Component Teardown

Warnings and Cautions	4-1
Door Strike	4-2
Loading Door	4-2
Loading Door Breakdown	4-2
Top Panel	4-3
Light Switch	4-3
Detergent Drawer	4-4
Detergent Drawer Disassembly	4-4
Releasing The Bellows (Door Boot) From Front Panel	4-5
Door Safety Switch	4-5
Console	4-6
Electronic Control Board	4-7
Removing The Delay Start Button	4-7
Removing The Interface Board	4-7
Removing The Selector Knob	4-7
Light Socket	4-8
Front Panel	4-8
Removing The Heater Control Board	4-9
Removing The light Transformer	4-9
Removing The Transformer And Heater control board mounting bracket	4-9
Console Mounting Bracket	4-10
Bellows	4-10
Reinstalling Or Replacing The Bellows	4-11
Weight Ring	4-12
External Drain Hose	4-12
Water Inlet And Overflow/Vent Tube Grommet	4-12
Overflow/Vent Tube	4-13
Water Inlet Valve	4-13
Water Inlet Screen	4-14

Section 4 Component Teardown (Continued)

Top Rear Brace	4-14
Suspension Springs	4-15
Top Center Brace	4-15
Detergent Cavity Assembly	4-16
Detergent Dispenser Outlet Hose.....	4-17
Siphon Break Hose	4-17
Drain Pump	4-17
Drain Pump Disassembly.....	4-18
Electric Water Level Sensor.....	4-18
Drain Sump	4-19
Drain Pump Outlet Hose	4-19
Drain Hose Coupler	4-20
Rear Access Panel	4-20
Drive Belt	4-20
Large Pulley.....	4-20
Drive Motor.....	4-21
Speed Control Board Assembly.....	4-21
Right Hand Air Shock Absorber.....	4-22
Left Hand Air Shock Absorber.....	4-23
Heating Element	4-23
Drum Water NTC.....	4-23
Air Bell	4-24
Tub Assembly	4-24
Spin Basket Vanes.....	4-26

Section 5 Troubleshooting

Troubleshooting Chart (Customer Use Related)	5-1
Troubleshooting Chart	5-2

Section 6 Wiring Diagrams

Affinity 7000 Series Wiring Diagram.....	6-1
Affinity 6000 Series Wiring Diagram.....	6-2

Recognize safety symbols, words and labels:

Safety items throughout this manual are labeled with a WARNING or CAUTION based on the risk type as described below:



WARNING

This symbol alerts you to situations that may cause serious body harm, death or property damage.



CAUTION

This symbol alerts you to situations that may cause bodily injury or property damage.

Read all of the following instructions before installing and using this appliance:

- Destroy the carton and plastic bags after the washer is unpacked. Children might use them for play. Cartons covered with rugs, bedspreads, or plastic sheets can become airtight chambers causing suffocation. Place all materials in a garbage container or make materials inaccessible to children.
- Clothes washer installation and service must be performed by a qualified installer or service agency.
- Install the clothes washer according to the manufacturer's instructions and local codes.
- The electrical service to the washer must conform with local codes and ordinances and the latest edition of the National Electrical Code, ANSI/NFPA 70, or in Canada, the Canadian electrical code C22.1 part 1.
- The washer is designed under ANSI Z 21.5.1 or ANSI/UL 2158 - CAN/CSA C22.2 No. 112 (latest editions) for HOME USE only. This washer is not recommended for commercial applications such as restaurants, beauty salons, etc.
- The instructions in this manual and all other literature included with this washer are not meant to cover every possible condition and situation that may occur. Good safe practice and caution MUST be applied when installing, operating and servicing any appliance.

Section 1 Basic Information

WARNING

To prevent personal injury or damage to the washer, the electrical power cord must be plugged into a properly grounded and polarized 3-prong outlet. The third grounding prong must never be removed.

Never ground the washer to a gas pipe.

Do not use an extension cord or an adapter plug.

ALWAYS disconnect the washer from the electrical supply before attempting any service or cleaning. Failure to do so can result in electrical shock or injury.

Do not use any type spray cleanser when cleaning washer interior. Hazardous fumes or electrical shock could occur.

To prevent injury, do not reach into the washer if the drum is moving. Wait until the washer has stopped completely before reaching into the drum.

To prevent injury and damage to the washer:

- Use only authorized factory parts.
- Do not tamper with controls.
- Do not install or store the washer where it will be exposed to the weather.

Protect Children

Do not allow children to play on or in the washer. Close supervision of children is necessary when the washer is used near children. As children grow, teach them the proper, safe use of all appliances.

Destroy the carton, plastic bag and other packing materials after the washer is unpacked. Children might use them for play. Cartons covered with rugs, bedspreads or plastic sheets can become airtight chambers.

Keep laundry products out of children's reach. To prevent personal injury, observe all warnings on product labels.

Before the washer is removed from service or discarded, remove the washer door to prevent accidental entrapment.

Failure to comply with these warnings could result in serious personal injuries.

Prevent Fire

Do not obstruct the flow of ventilating air. Do not stack or place laundry or throw rugs against front or back of washer.

Do not use fabric softeners or products to eliminate static unless recommended by the manufacturer of the fabric softener or product.

Failure to comply with these warnings could result in fire, explosion, serious bodily injury and/or damage to the rubber or plastic parts of the washer.

Section 1 Basic Information

Serial Number Breakdown

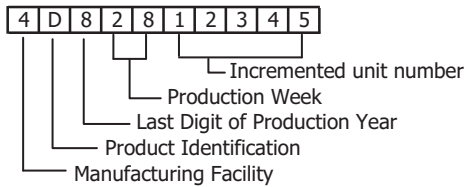

Model Number Breakdown

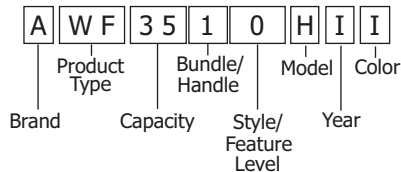

Figure 1-1. Serial Tag Location

Drum Water Height

Water fill height $3.5 \pm .5$ "
 No load, start position of permanent press cycle.
 (See Figure 1-2)

Water Usages

Based on 1 wash and 3 rinse fills.
 Per fill..... 4.23 gallons
 Per cycle..... 16.92 gallons

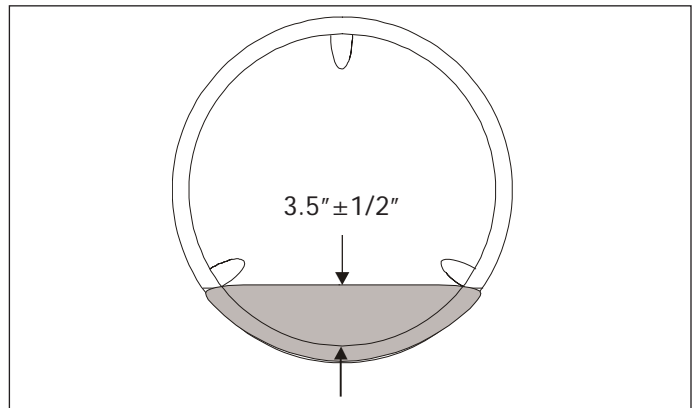

Figure 1-2. Drum Water Height

Motor Specifications

No load agitate wattage - Max 150
 No load spin wattage - Max 550
 Tub Pulley to Motor Pulley Ratio - 16 To 1

Component Resistance Chart

Electrical component	Resistance Ω @ 77°F (25°C)	
Dispenser valve solenoids	800 \pm 7%	
Door lock solenoid	1325 \pm 10%	
Pump motor	12 \pm 7%	
NTC Thermistor dispenser	3K	
NTC Thermistor heater	4.8K	
Water heater	14 \pm 10%	
Motor	M1 TO M2	5.3 \pm 7%
	M2 TO M3	5.3 \pm 7%
	M1 TO M3	5.3 \pm 7%
	M4 TO M5	118 \pm 7%

Automatic Temperature Control Specifications

Auto Temp Sanitary Cycle..... 152° \pm 7° F
 Auto Temp HOT/COLD settings..... 120° \pm 7° F
 Auto Temp WARM/WARM
 and WARM /COLD settings 90° \pm 7° F
 Auto Temp COLD/COLD settings 65° \pm 7° F

Section 1 Basic Information

Control

The control is mounted to the back of the console. (See Figure 1-3) The control:

1. Provides power to the dispenser solenoids, wax motor, door lock solenoid, drain pump and speed control board.
2. Sends signals to the speed control board to tell it what program to run and the heater control board to control the heater.
3. Checks the status of the door switches, door light switch, incoming water sensor and the drum water sensor.

Drum Light Assembly (On select models)

The drum light assembly is made up of a 12 volt AC, 5 watt light that is embedded in the bellows, a push button switch that is closed when the door is open, and a step down transformer that reduces the voltage from 120 Volts to 12 Volts. (See Figure 1-4)

A circuit in the electronic control turns the light off when the door is left open for more than three minutes. (See Figure 1-6)

Door Switch Assembly

The door switch assembly, located behind the front panel, is a safety feature that prevents the washer from operating when the door is open and locks the door in the spin cycle. (See Figure 1-5)

Door Lock Assembly

The door lock assembly is made up of a coil, door switch, switch actuator, locking fork, wax motor, auxiliary switch and spin lock arm. (See Figure 1-7)

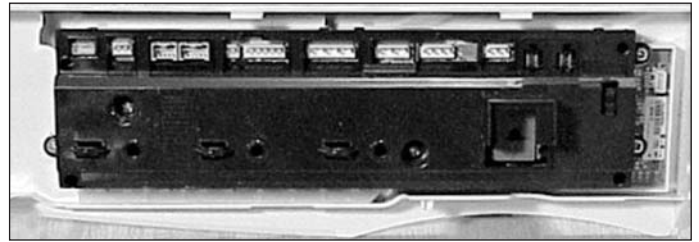

Figure 1-3. Control

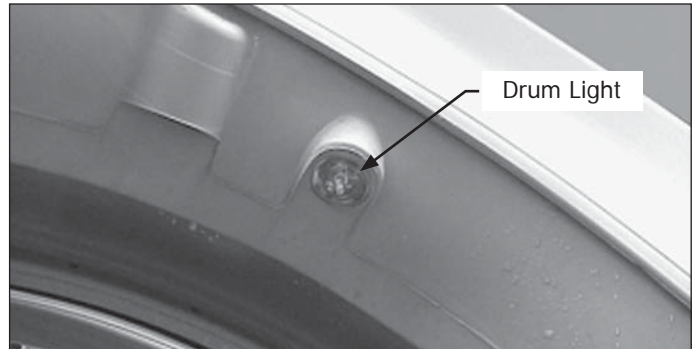

Figure 1-4. Drum Light



Figure 1-5. Door Switch

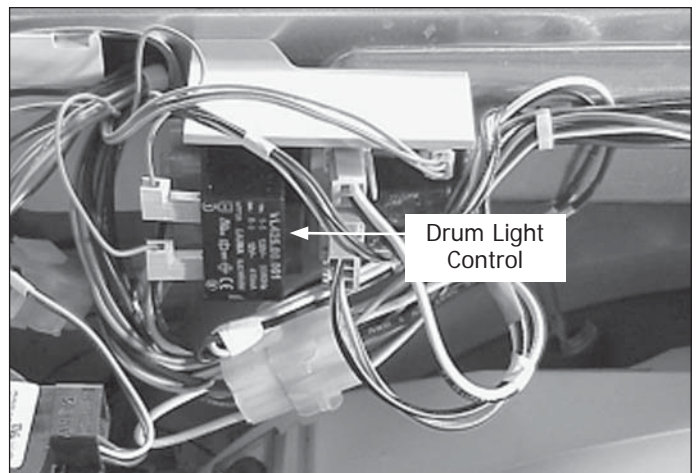

Figure 1-6. Light Control

Door Lock Assembly (Continued)

When a cycle is selected and the start pad is touched, the control board applies power to the coil. The magnetic field of the coil pulls the locking fork down and tries to pull the contacts of the door lock switch closed. If the washer door is open, a tab on the switch actuator prevents the contacts from closing and the locking fork will not allow the door to be closed until the stop pad is touched, removing current from the coil. When the washer door is closed, the door strike pivots the switch actuator out of the way allowing the magnetic field of the coil to close the contacts of the door lock switch and the locking fork locks the door. (See Figure 1-7)

The wax motor and spin lock arm are used to prevent the door from being opened while the spin basket is still spinning. Power is applied to the wax motor when the washer is in spin. When power is applied to the wax motor, it expands its piston within 30 to 40 seconds, driving the spin lock arm between the locking fork and switch actuator holding the locking fork down. At the same time, the piston closes the door lock auxiliary switch allowing the washer to go into spin. When power is removed from the wax motor, it takes about 90 seconds for the wax motor to cool down and retract the piston, pulling the spin lock arm back away from the locking fork and auxiliary switch. This provides enough time for the spin basket to slow its rotation down to the wash speed before the door could possibly be opened.

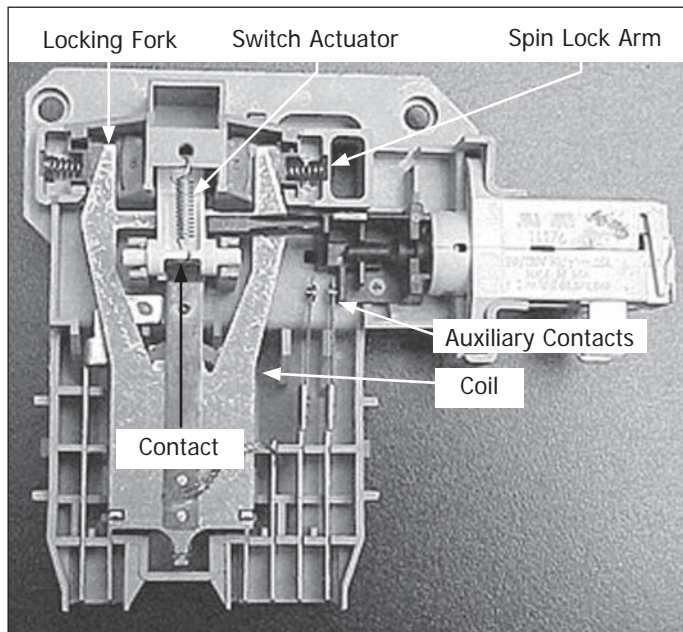

Figure 1-7. Door Lock Assembly

Pressure Switch (Select models)

The pressure switch is mounted to the right side panel under the top of the washer and controls the water level in the washer. (See Figure 1-8)

The pressure switch is made up of a single pole double throw switch, but only contacts 1 and 2 are used. The contacts are controlled by a bellows inside a sealed chamber. The chamber is connected by a hose to the air bell located at the bottom of the washer attached to the drain boot. L1 power is applied to the pressure switch by the control. If the water level is below 1/2 inch from the bottom of the spin basket, contacts 1 to 2 of the pressure switch close, applying power to one side of the (3) solenoids of the water valve assembly. The other side of the solenoids is connected to neutral by a relay contacts on the control board. When the cycle calls for water, depending on the water temperature selected and the increment of the cycle, the control board connects one or two of three the solenoid coils to neutral activating the water valve solenoids. When the corrected water level is reached contacts 1 and 2 open, signaling the control to remove neutral from the solenoids.

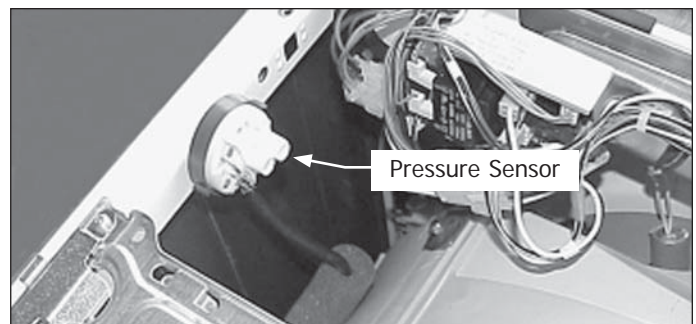

Figure 1-8. Pressure Sensor

Section 1 Basic Information

Electronic Water Level Sensor

The electronic water level sensor is mounted to the right side panel under the top of the washer and controls the water level in the washer. (See Figure 1-9)

The electronic water level sensor is made up of an electronic board and a bellow inside a sealed chamber. The chamber is connected by a hose to the air bell located at the bottom of the washer attached to the drain boot. The electronic board reads the pressure in the bellow and converts it into an electronic signal. This signal is then sent to the control board which governs the incoming water by connecting or disconnecting a neutral line to the water solenoids.

Water Inlet Valve Assembly

The water inlet valve assembly is made up of a plastic housing, 2 tubes, which the inlet water hoses are connected to, 3 solenoids and a positive thermal sensor. The hot solenoid is connected to the incoming hot water. The wash and bleach solenoids share a common input cavity that is connected to the cold water supply. (See Figure 1-11)

The hot and wash solenoids share a common output cavity, with the bleach solenoid having a separate output cavity. (See Figure 1-12)

Water Valve Operation

The (3) inlet solenoid valves are identical in construction and operation. The valve body provides an air passage with a large orifice and seat where the water can be stopped. The outlet of the valve body empties into a chamber. A moveable rubber diaphragm operates against the valve seat to start and stop the flow of water. The diaphragm is operated by water pressure. It has a small bleed orifice outside the seat contact area, and a large main orifice at its center. The armature of the solenoid serves to open and close the main orifice. The armature operates within a closed metal tube (valve guide) which is sealed by the outer edge of the diaphragm to the valve body. A coil spring holds the armature down against the diaphragm main orifice when the solenoid is not energized.

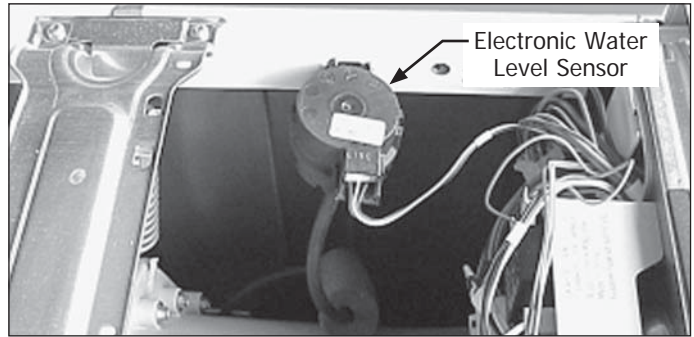

Figure 1-9. Water Level Sensor

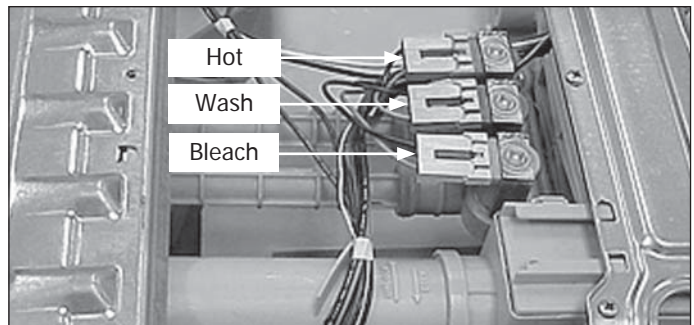

Figure 1-10. Inlet Water Valves

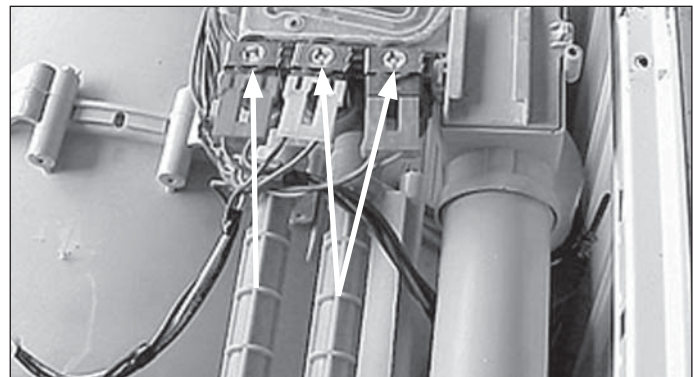

Figure 1-11. Water Valve Inlet

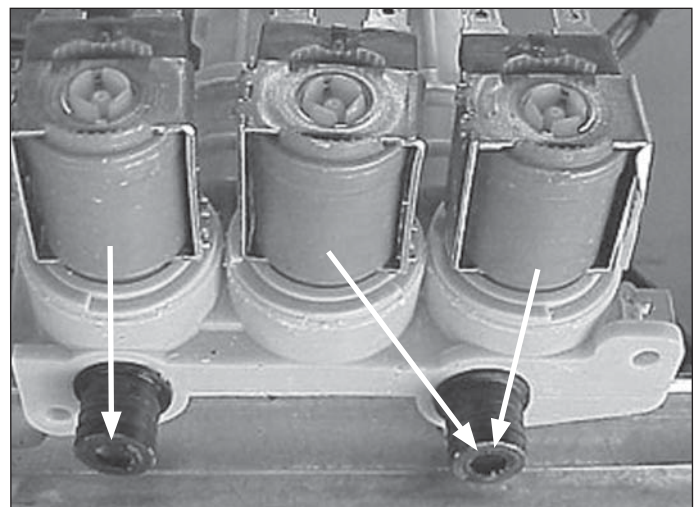

Figure 1-12. Water Valve Outlet

Section 1 Basic Information

The following line drawings and text explains basic valve operation.

When the valve is in a closed position, the solenoid is not energized. Water has bled through the diaphragm bleed orifice placing incoming line pressure on top of the diaphragm. The bottom of the diaphragm is essentially at atmospheric pressure (open to the outlet) and the pressure differential holds the valve shut.

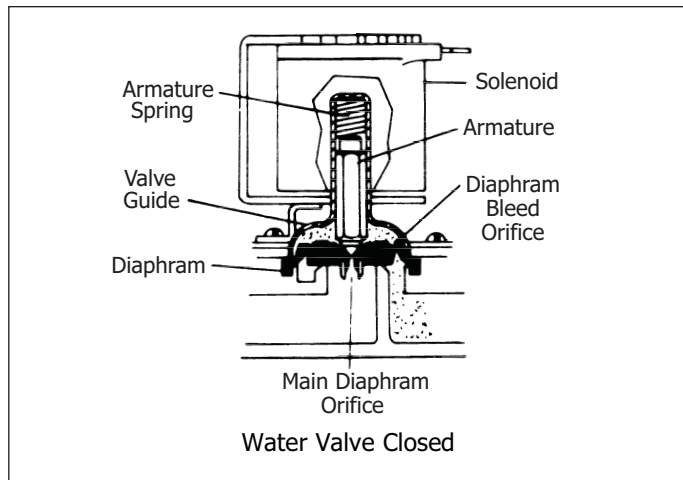

Figure 1-13.

When the solenoid is energized, the resulting magnetic field pulls the armature up into the valve guide. The armature spring is compressed by this action. When the armature moves up, it allows the water on the top of the diaphragm to drain through the main orifice.

The diaphragm bleed orifice is much smaller than the main orifice and will not admit enough water to maintain pressure on the top side of the diaphragm. Thus, as the pressure on the top of the diaphragm is reduced to almost zero, pressure on the bottom lifts the diaphragm off the valve seat, allowing a full flow of water.

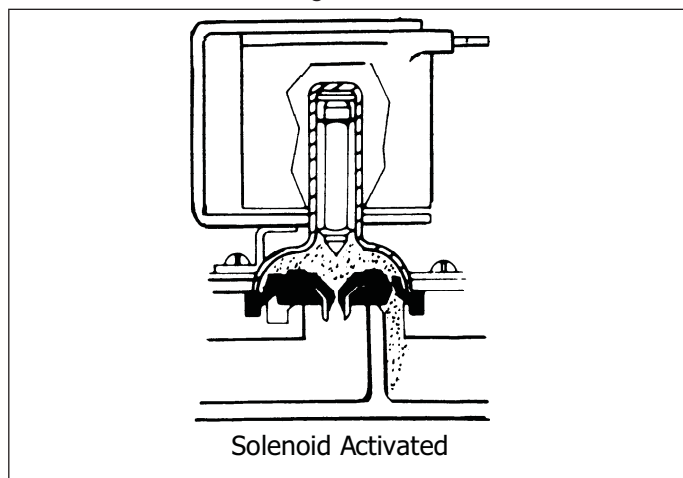

Figure 1-14.

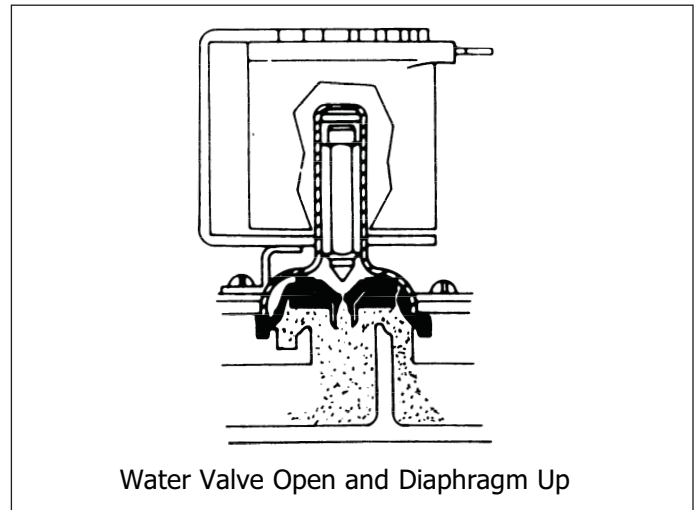

Figure 1-15.

When the solenoid is de-energized, the armature drops down, closing the diaphragm main orifice. Water continues to flow through the diaphragm bleed orifice, equalizing the pressure and allowing the spring to push the diaphragm down against the valve seat.

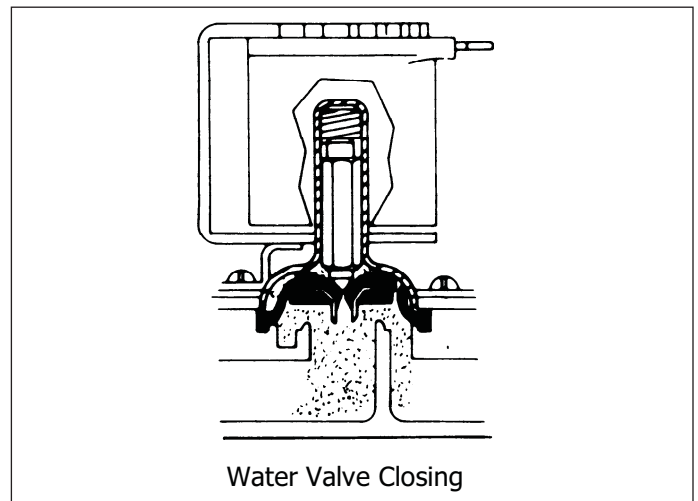

Figure 1-16.

Section 1 Basic Information

Water Temperature

When AUTO TEMP switch is set to HOT/COLD in the wash cycle, the hot solenoid is activated and the bleach solenoid is deactivated for all except the last fill in rinse. For the last rinse fill, the wash and bleach solenoids are activated. When AUTO TEMP switch is set to WARM/COLD in the wash cycle, the hot and wash solenoids are activated and the Bleach solenoid is deactivated, for all except the last fill in rinse. For the last rinse fill, the wash and bleach solenoids are activated. When the AUTO TEMP switch is set to WARM/WARM in the wash cycle, the hot and wash solenoids are activated and the Bleach solenoid is deactivated for all except the last fill in rinse. For the last rinse fill, the hot and bleach solenoids are activated. When the AUTO TEMP switch is set to COLD/COLD, the wash solenoid is activated and the hot solenoid cycles to warm the water to 65°. For the last rinse fill, the wash and bleach solenoids are activated. When the TEMP switch is set to COLD/COLD in the wash cycle, the wash solenoid is activated and the bleach solenoid is deactivated for all except the last fill in rinse. For the last rinse fill, the wash and bleach solenoids are activated.

Auto Temp System

The auto temp system controls the minimum temperature of the cold water setting (approximately 65°F.) and the temperature of the warm and hot water setting (approximately 90°F and 120°F). On select models with a sanitary wash cycle, when the control is set to sanitary wash, the water temperature is raised to 152°F in the wash cycle. The auto temp system is made up of the control board and a positive thermal sensor mounted in the water inlet valve assembly. On select models, a positive thermal sensor (drum sensor), a heater control board, and a 1000 watt heating element located in the bottom rear of the drum are added to auto temp system. If the hot water supply in the house is below the auto temp setting, the drum heater heats the water in the wash cycle. (See Figure 1-20)

When a warm or hot temperature is selected in the wash cycle, the control board connects the hot water solenoid to neutral and cycles the center cold water solenoid off and on to regulate the temperature. When a cold temperature is selected, the control board connects the center cold water solenoid to neutral and cycles the hot water solenoid off and on to regulate the temperature. When a warm rinse is selected for the final rinse, the control connects the outside cold solenoid to neutral and cycles the hot solenoid.

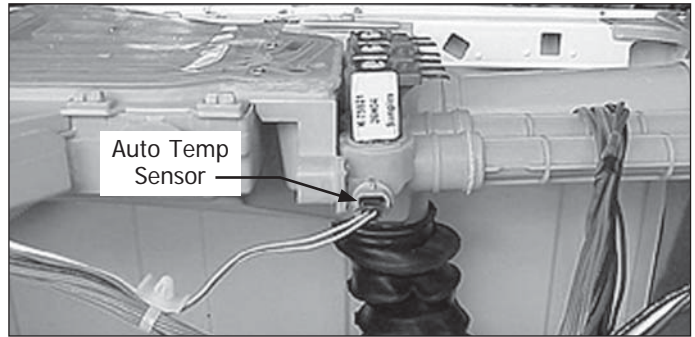

Figure 1-17. Auto Temp Sensor Location

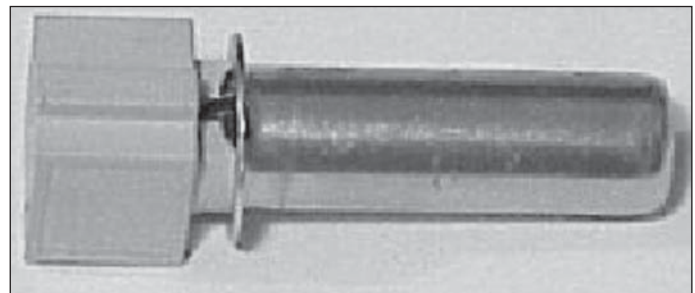

Figure 1-18. Positive Thermal Sensor

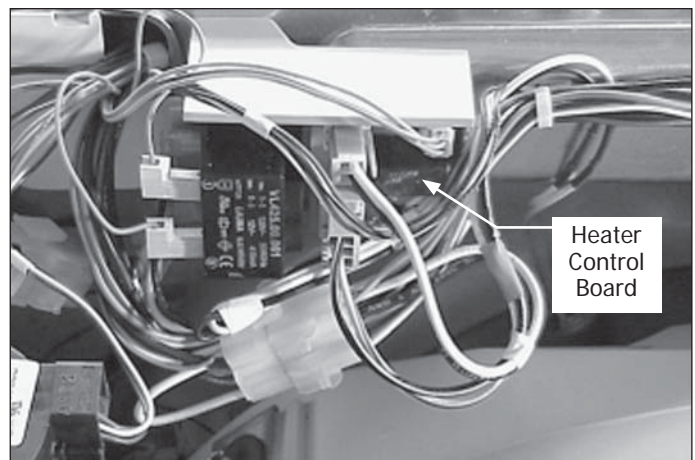

Figure 1-19.

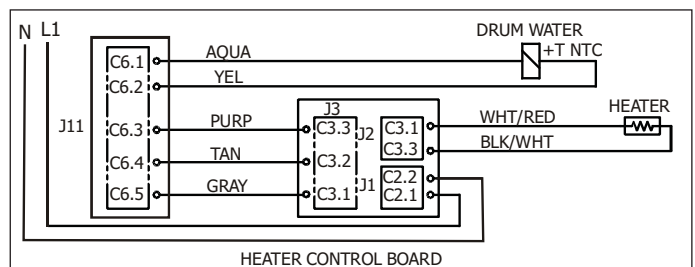

Figure 1-20.

Automatic Dispenser

The automatic dispenser for detergent, liquid bleach and fabric softener system is made up of the dispenser cavity, and a removable drawer with three cavities: one for detergent, one for bleach and one for fabric softener. A plastic conveyer is snapped to the bottom of the drawer to direct the outputs from the bleach and softener chambers to the dispenser housing outlet channel. This prevents the mixtures from coming out the front of the drawer. (See Figure 1-21 & 1-22)

The 2 outlets of the water inlet valve assembly are inserted into the rear of the automatic dispenser. During the fill cycles, water is directed into the top of the cavity through 2 inlets. The inlet on the right, as viewed from the front of washer, is connected to the combination output of the hot water solenoid and the center cold water solenoid.

The inlet on the left, as viewed from the front of the washer, is connected to the cold water solenoid.

In the fill cycle, water enters into the top of cavity and is directed across the top of the cavity by 4 channels: the dispenser bypass channel, the detergent channel, bleach channel and the fabric softener channel. The channel that receives the water is determined by which inlet supplies the water or if both inlets supply the water. (See Figure 1-23)

The dispenser advanced rinsing technology channel receives water whenever the inlet on the right, as viewed from the front of the washer, is activated. (See Figure 1-24)

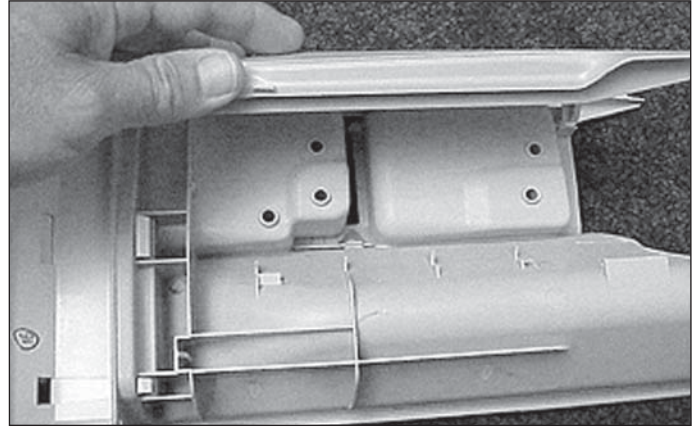

Figure 1-22.

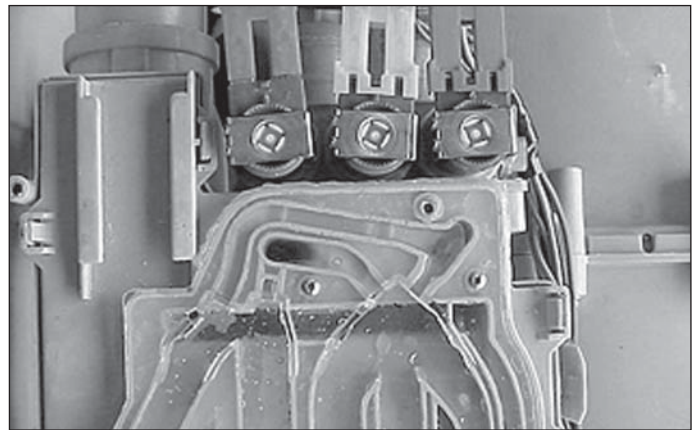

Figure 1-23.

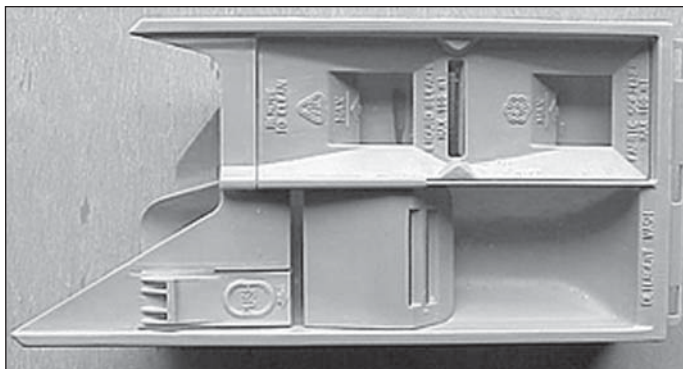

Figure 1-21.

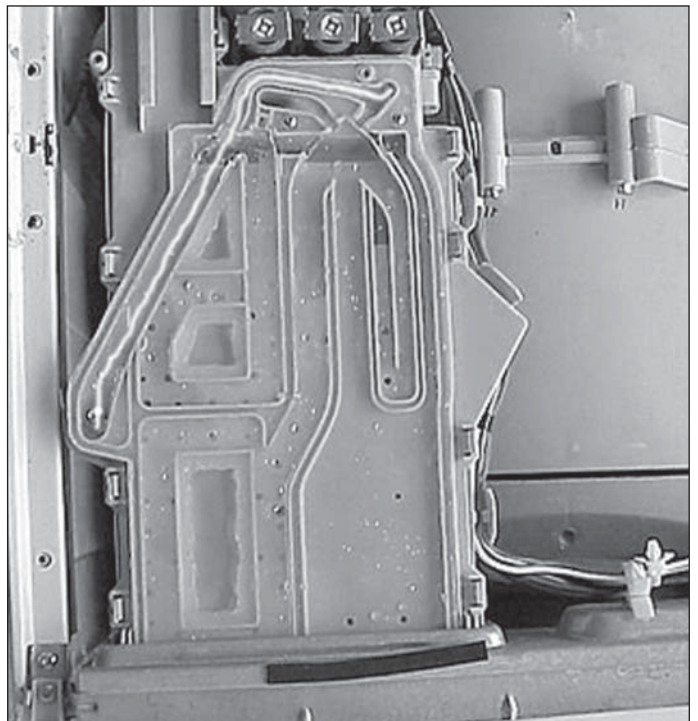

Figure 1-24.

Section 1 Basic Information

This path allows the water to bypass the dispenser drawer and enter the tub by the advanced rinsing technology hose connected between the cavity and the bellows. (See Figure 1-25)

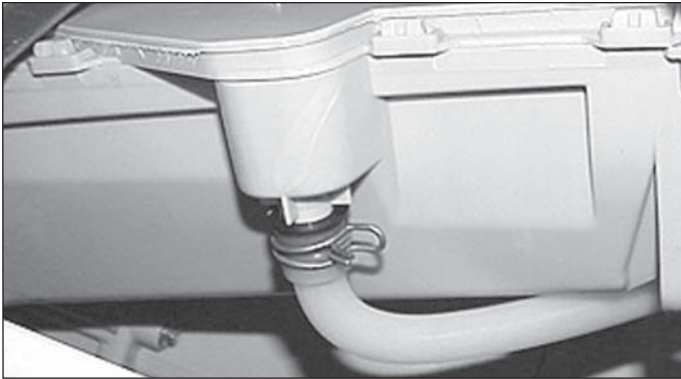

Figure 1-25.

The detergent dispenser channel receives water from the right-hand input, as viewed from the front of the washer. The detergent channel forms a loop that allows the water to pass over the detergent section of the drawer. (See Figure 1-26)

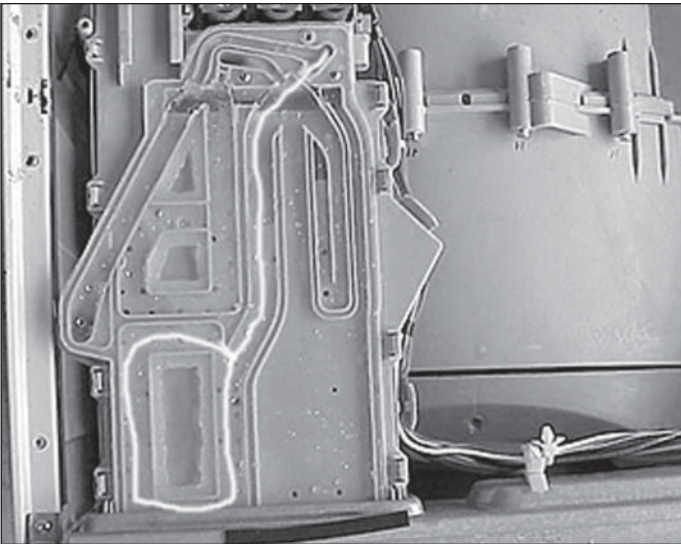

Figure 1-26.

As the water pass over the detergent section, holes in the cavity allows some of the water to enter and flush the detergent cavity. (See Figure 1-27)

Since the flow of the incoming water is more than the holes can dispense, the excess water backs up into a channel across the rear of the dispenser. (See Figure 1-28)

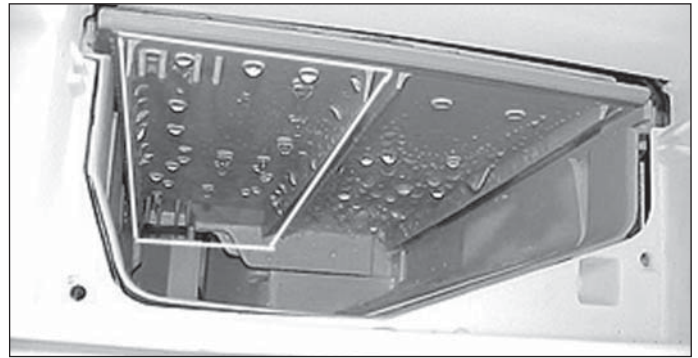

Figure 1-27.

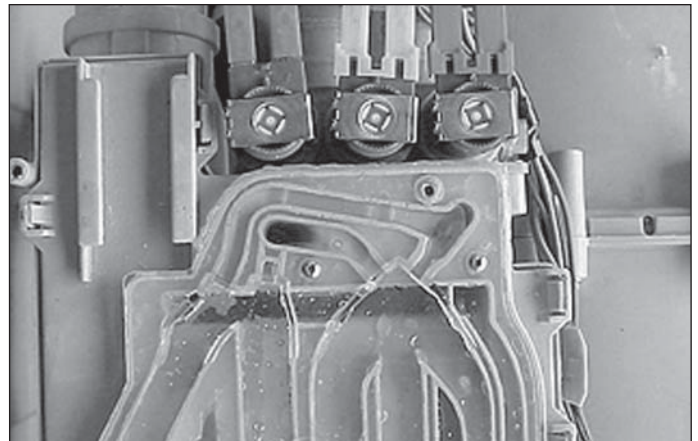

Figure 1-28.

Water in this channel and the mixture from the detergent drawer flow into the tub through the large hose at the rear of the dispenser. (See Figure 1-29)



Figure 1-29.

Section 1 Basic Information

Detergent is dispensed at the start of the cycle, but bleach and fabric softener are not dispensed until later in the cycle. The bleach and softener cavities in the drawer have tubes molded into the bottom of them. These tubes allow bleach or fabric softener to be added to their cavity without being dispensed as long as the liquid is below the top of the tubes. At the proper time in the cycle when bleach or fabric softener is to be dispensed, water is added to the cavity. This raises the mixture above the top of the tube and the bleach or fabric softener starts flowing into the tub.

To allow the cavities to empty, the cover of the detergent drawer cover has tubes molded into it that fit over the tubes in the cavities. (See Figure 1-30 & 1-31)

These tubes are larger than the tubes in the cavity and are designed to fit over the tubes, but not touch the bottom of the cavity when the cover is installed. When water is added to either the bleach or fabric softener liquid, the mixture level rises between the tubes above the tubes in the cavity and flows into the washer tub. Since the end of the tube on the insert does not touch the bottom of the cavity, a siphoning action will occur when the solenoid activates and allows water into the cavity. The added water creates an "overflow" condition and starts the siphoning. The cavity will empty itself when the water is turned off by the solenoid. (See Figure 1-31)

The bleach dispenser channel receives water from the left-hand input, as viewed from the front of the washer. The bleach channel forms a path, that allows the water to pass over the bleach cavity section of the cavity. (See Figure 1-32)

As the water passes over the bleach section, holes in the cavity allow some of the water to enter and mix with the bleach. This raises the mixture level above the tubes in the drawer bleach cavity allowing the mixture to flow into the tub. (See Figure 1-33)

Like the detergent channel, the flow of the incoming water is more than the holes can dispense allowing the excess water to backup into the channel across the rear of the dispenser and flow into the tub.

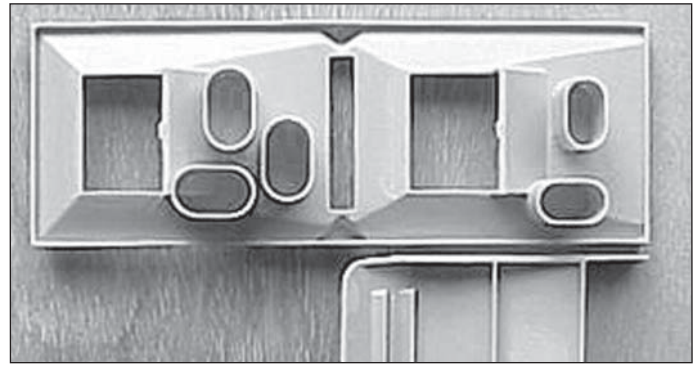

Figure 1-30.

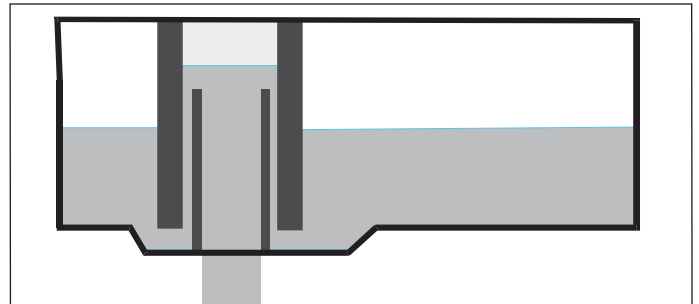

Figure 1-31.

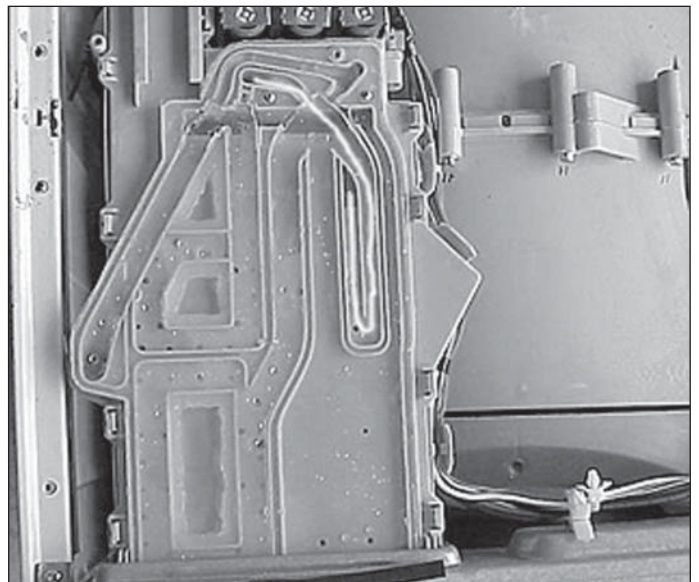

Figure 1-32.

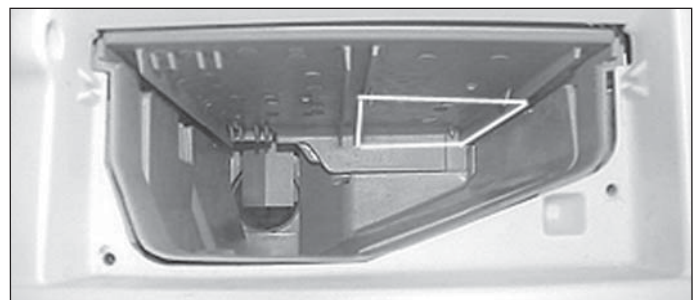

Figure 1-33 .

Section 1 Basic Information

For water to enter the fabric softener channel, both the left and right inlets must be activated. As the water from the left inlet pass over the channel, it collides with the water from the right inlet. This collision changes the water path directing it to the front of the cavity and into the fabric softener channel. The fabric softener channel forms a loop that allows the water to pass over the fabric softener cavity section of the drawer.

(See Figure 1-34 & 1-35)

As the water passes over the fabric softener section, holes in the cavity allow some of the water to enter and mix with the fabric softener. This raises the mixture level above the tubes in the drawer fabric softener cavity allowing the mixture to flow into the tub. Like the detergent channel, the flow of the incoming water is more than the holes can dispense, allowing the excess water to backup into the channel across the rear of the dispenser and flow into the tub.

Drain Pump

The drain pump is mounted to the bottom plate of the washer behind the access panel. It operates on 120 VAC and is controlled by the control board and pressure switch. The pump out specifications of the drain pump vary from 12 G.P.M. with a 3 foot standpipe height to 5 G.P.M. with a 8 foot standpipe height. (See Figure 1-36)

Motor

The motor is mounted to the bottom of the outer tub. The motor is an induction, three phase AC motor that varies speeds when the voltage from the speed control board varies in frequency and amount. (See Figure 1-37) The motor has a tachogenerator that inputs the speed of the motor to the speed control board.

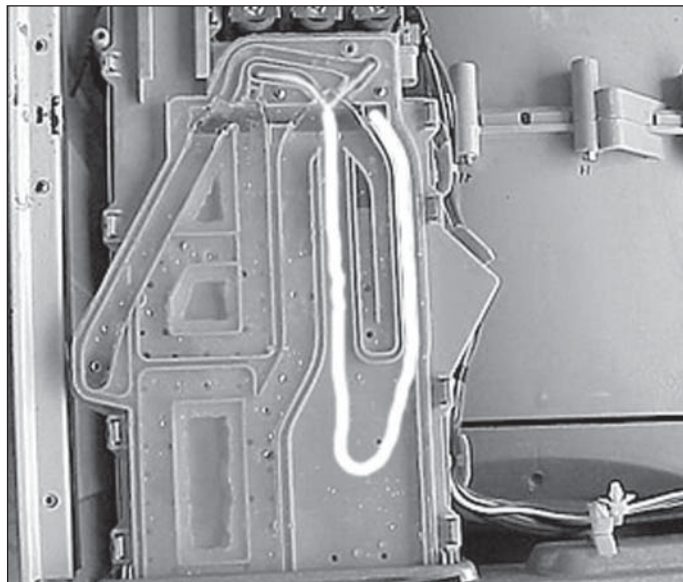

Figure 1-34.

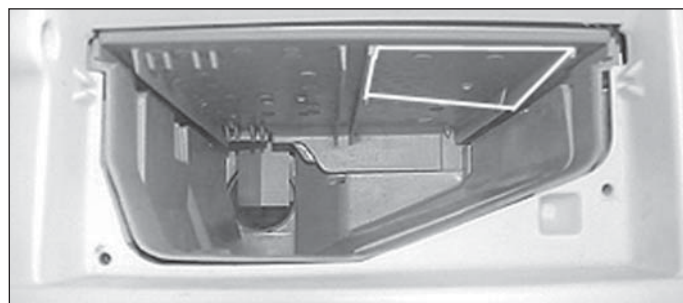

Figure 1-35.

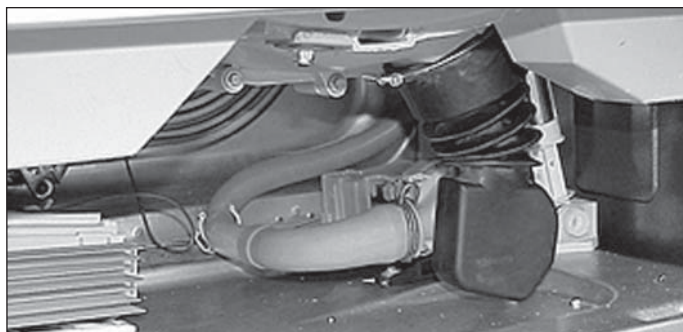

Figure 1-36.

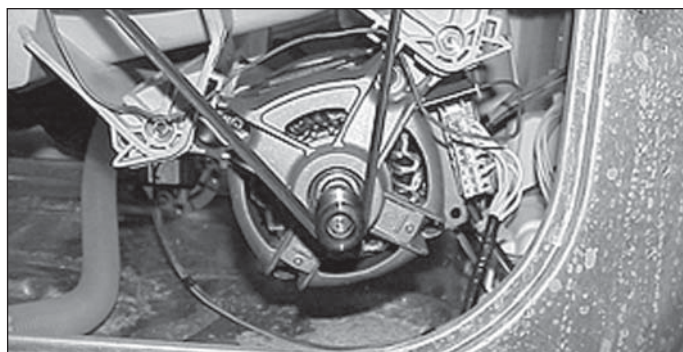

Figure 1-37.

Speed Control

The speed control board is mounted to the base plate of the washer in the left rear corner of the washer. The speed control board controls the following operations:

1. The speed of the drive motor by converting input line to neutral single phase 60 Hertz voltage, to a varying frequency, three phase output voltage from zero to 300 VAC. By varying the amount, frequency, and polarity of the voltage and comparing the input from the tachogenerator on the drive motor, the speed control board can operate the drive motor at a pre programmed speed and direction.
2. The balance of the load in the washer during the spin cycle by converting the sine wave from the tachogenerator to square waves and comparing the distance between the square waves.

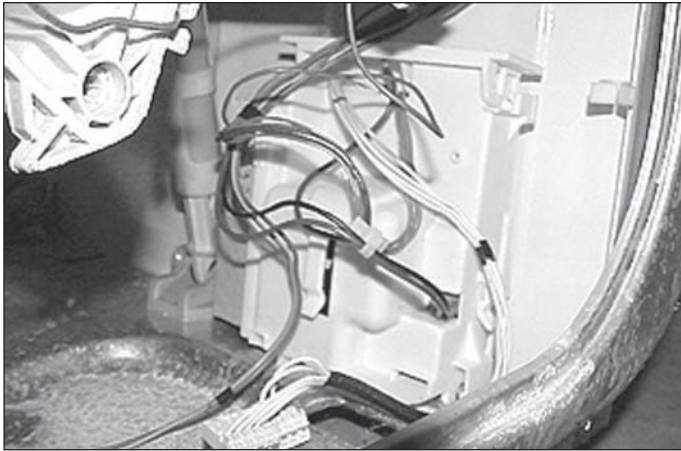

Figure 1-38. Speed Control

Tub Construction

The front loading tumble action clothes washer consists of a perforated, cylindrical spin basket suspended horizontally on its axis within a larger solid cylindrical tub. This assembly is suspended by springs within a four piece steel cabinet. A see through door and a flexible bellows (seal) provides access for loading and unloading.

Cabinet

The cabinet is made of heavy steel in a four piece design. The sides and rear are Tog-I-locked at the rear corners and base. The rear of the cabinet is galvanized steel with an access panel.

Front Panel and Door Assembly

The front panel is attached with screws to the console mounting brace and base plate.

Bellows

The bellows is a rubber sleeve that seals the suspended outer tub to the stationary cabinet front at the tub opening. Its purpose is to provide a water tight opening into the tub that can be sealed by the cabinet door, yet allow flexibility for the oscillation of the tub during the wash and spin cycles.

Outer Tub Assembly

The outer tub assembly is supported by two suspension springs and stabilized by two air shock assemblies. A cement counter weight mounted to the front of the outer tub. Another weight is molded into the rear half of the outer tub. These counterweights prevent excessive oscillation of the entire suspended assembly during an unbalanced spin cycle.

Spin Basket Assembly

The spin basket is constructed of stainless steel. The circumference of the basket is perforated to allow water to flow through it as it revolves. A heavy steel shaft is pressed into the spin basket support which is then bolted to the basket. The spin basket assembly is entirely supported by two ball bearing assemblies pressed into the rear of the outer tub.

A large drive pulley is mounted to the free end of the shaft that extends through the rear of the outer tub. There are three plastic vanes mounted to the spin basket to aid in the washing action during the wash cycle. The rotation of the spin basket provides both the washing action during the wash cycle and water extraction during the spin cycle.

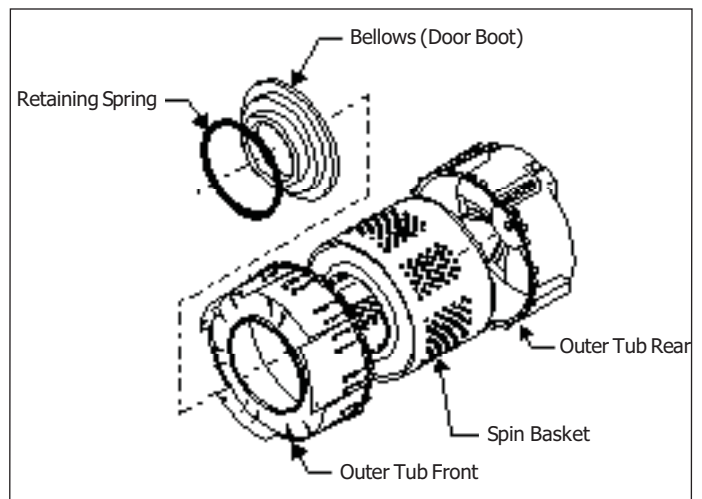

Figure 1-39.

Section 1 Basic Information

Major Appliance Warranty Information

Your appliance is covered by a one year limited warranty. For one year from your original date of purchase, Electrolux will pay all costs for repairing or replacing any parts of this appliance that prove to be defective in materials or workmanship when such appliance is installed, used and maintained in accordance with the provided instructions.

- Exclusions This warranty does not cover the following:
1. Products with original serial numbers that have been removed, altered or cannot be readily determined.
 2. Product that has been transferred from its original owner to another party or removed outside the USA or Canada.
 3. Rust on the interior or exterior of the unit.
 4. Products purchased "as-is" are not covered by this warranty.
 5. Food loss due to any refrigerator or freezer failures.
 6. Products used in a commercial setting.
 7. Service calls which do not involve malfunction or defects in materials or workmanship, or for appliances not in ordinary household use or used other than in accordance with the provided instructions.
 8. Service calls to correct the installation of your appliance or to instruct you how to use your appliance.
 9. Expenses for making the appliance accessible for servicing, such as removal of trim, cupboards, shelves, etc., which are not a part of the appliance when it is shipped from the factory.
 10. Service calls to repair or replace appliance light bulbs, air filters, water filters, other consumables, or knobs, handles, or other cosmetic parts.
 11. Surcharges including, but not limited to, any after hour, weekend, or holiday service calls, tolls, ferry trip charges, or mileage expense for service calls to remote areas, including the state of Alaska.
 12. Damages to the finish of appliance or home incurred during installation, including but not limited to floors, cabinets, walls, etc.
 13. Damages caused by: services performed by unauthorized service companies; use of parts other than genuine Electrolux parts or parts obtained from persons other than authorized service companies; or external causes such as abuse, misuse, inadequate power supply, accidents, fires, or acts of God.

DISCLAIMER OF IMPLIED WARRANTIES; LIMITATION OF REMEDIES

CUSTOMER'S SOLE AND EXCLUSIVE REMEDY UNDER THIS LIMITED WARRANTY SHALL BE PRODUCT REPAIR OR REPLACEMENT AS PROVIDED HEREIN. CLAIMS BASED ON IMPLIED WARRANTIES, INCLUDING WARRANTIES OF MERCHANTABILITY OR FITNESS FOR A PARTICULAR PURPOSE, ARE LIMITED TO ONE YEAR OR THE SHORTEST PERIOD ALLOWED BY LAW, BUT NOT LESS THAN ONE YEAR. ELECTROLUX SHALL NOT BE LIABLE FOR CONSEQUENTIAL OR INCIDENTAL DAMAGES SUCH AS PROPERTY DAMAGE AND INCIDENTAL EXPENSES RESULTING FROM ANY BREACH OF THIS WRITTEN LIMITED WARRANTY OR ANY IMPLIED WARRANTY. SOME STATES AND PROVINCES DO NOT ALLOW THE EXCLUSION OR LIMITATION OF INCIDENTAL OR CONSEQUENTIAL DAMAGES, OR LIMITATIONS ON THE DURATION OF IMPLIED WARRANTIES, SO THESE LIMITATIONS OR EXCLUSIONS MAY NOT APPLY TO YOU. THIS WRITTEN WARRANTY GIVES YOU SPECIFIC LEGAL RIGHTS. YOU MAY ALSO HAVE OTHER RIGHTS THAT VARY FROM STATE TO STATE.

- If You Need Service Keep your receipt, delivery slip, or some other appropriate payment record to establish the warranty period should service be required. If service is performed, it is in your best interest to obtain and keep all receipts. Service under this warranty must be obtained by contacting Electrolux at the addresses or phone numbers below.

This warranty only applies in the USA and Canada. In the USA, your appliance is warranted by Electrolux Major Appliances North America, a division of Electrolux Home Products, Inc. In Canada, your appliance is warranted by Electrolux Canada Corp. Electrolux authorizes no person to change or add to any obligations under this warranty. Obligations for service and parts under this warranty must be performed by Electrolux or an authorized service company. Product features or specifications as described or illustrated are subject to change without notice.

USA
1.800.944.9044
Electrolux Major Appliances
North America
P.O. Box 212378
Augusta, GA 30907



Canada
1.800.668.4606
Electrolux Canada Corp.
5855 Terry Fox Way
Mississauga, Ontario, Canada
L5V 3E4

Section 2 Installation Information

WARNING

To reduce the risk of fire, electrical shock, or injury when using a Frigidaire Affinity Washer, follow basic safety precautions including the following:

- Read all instructions before operating the washer.
- Before performing any type of service or installation, make sure that electric power to the washer is disconnected.
- To avoid the possibility of explosion or fire, do not store or use combustible, flammable, or explosive liquids or vapors (such as gasoline) inside or in the vicinity of this or any other appliance.
- This appliance is equipped with a three-prong grounding plug for protection against possible electric shock hazards. Plug it only into a dedicated, grounded electrical outlet. When only a standard two-prong electrical outlet is available, the customer must have it replaced with a dedicated, properly grounded three-prong electrical outlet before using this Appliance.
 - Do not under any circumstances, cut or remove the third (ground) prong from the power cord.
 - Do not use an adapter plug.
 - Do not use an extension cord.
 - Do not use a power cord that is frayed or damaged.
 - The use of a ground fault interrupter (GFI) is not recommended.
- Do not install or use a damaged appliance. If you receive a damaged appliance, immediately contact your dealer or builder.
- The installer must show the customer the location of the power plug so that they know where and how to disconnect power to the washer.
- The customer should not install, repair or replace any part of the washer unless specifically recommended in the literature accompanying it. A qualified service technician should perform all other service.

DANGER

WHAT TO DO IF YOU SMELL GAS:

- Do not try to light any appliance.
- Do not touch any electrical switch; do not use any phone in your building.
- Clear the room, building or area of all occupants.
- Immediately call your gas supplier from a neighbor's phone. Follow the gas supplier's instructions.
- If you cannot reach your gas supplier, call the fire department.

WARNING

Destroy carton, plastic bags, and any exterior wrapping material immediately after the Washer is unpacked. Children should never use these items for play. Cartons covered with rugs, bedspreads, plastic sheets or stretch wrap may become air tight chambers and can quickly cause suffocation.

Keep laundry products out of children's reach. To prevent personal injury, observe all warnings on product labels.

Cut Hazard. To prevent serious injury from sharp edges, wear work gloves when handling, unpacking or disassembling unit.

WARNING

Electrolux cannot be held responsible for damage to property or injury to persons caused by failure to comply with the installation, maintenance and safety instructions contained in this Service Manual.

Section 2 Installation Information

Pre-Installation Requirements

Tools and materials needed for installation:

- Channel lock adjustable pliers
- Phillips, straight, & square bit screw-drivers
- Adjustable wrench
- 10 mm socket with ratchet
- Carpenter's level

Electrical System Requirements

Circuit - Individual, properly polarized and grounded 15 amp. branch circuit fused with 15 amp. time delay fuse or circuit breaker.

Power Supply - 2 wire, with ground, 120 volt single phase, 60 Hz, alternating current.

NOTE

Because of potentially inconsistent voltage capabilities, the use of this washer with power created by gas powered generators, solar powered generators, wind powered generators or any other generator other than the local utility company is not recommended.

GFI (Ground Fault Interrupter) receptacle is not required.

Outlet Receptacle - Properly grounded 3-prong receptacle to be located so the power supply cord is accessible when the washer is in an installed position.

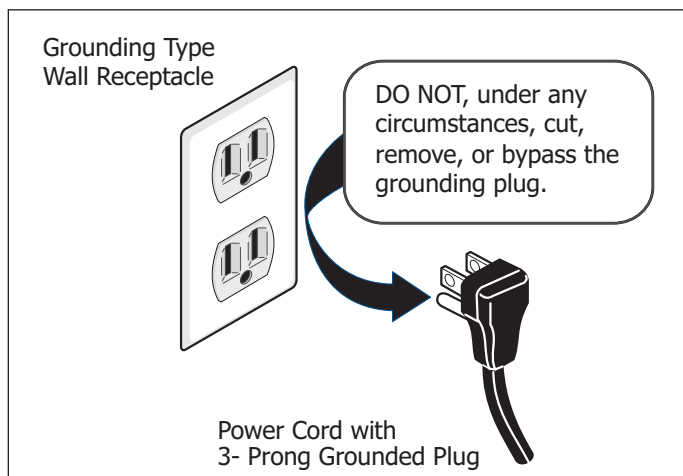

Figure 2-1. Electrical Connection

Grounding Requirements

WARNING

Improper connection of the equipment grounding conductor can result in a risk of electrical shock. Check with a licensed electrician if you are in doubt as to whether the appliance is properly grounded.

1. The washer **MUST** be grounded. In the event of malfunction or breakdown, grounding will reduce the risk of electrical shock by a path of least resistance for electrical current.
2. This washer is equipped with a power supply cord having an equipment-grounding conductor and a grounding plug, the plug **MUST** be plugged into an appropriate, copper wired receptacle that is properly installed and grounded in accordance with all local codes and ordinances or in the absence of local codes, with the National Electrical Codes, ANSI/NFPA 70 (latest edition). If in doubt, call a licensed electrician. **DO NOT** cut off or alter the grounding prong on the power supply cord. In situations where a two-slot receptacle is present, it is the owner's responsibility to have a licensed electrician replace it with a properly grounded three prong grounding type receptacle.

Section 2 Installation Information

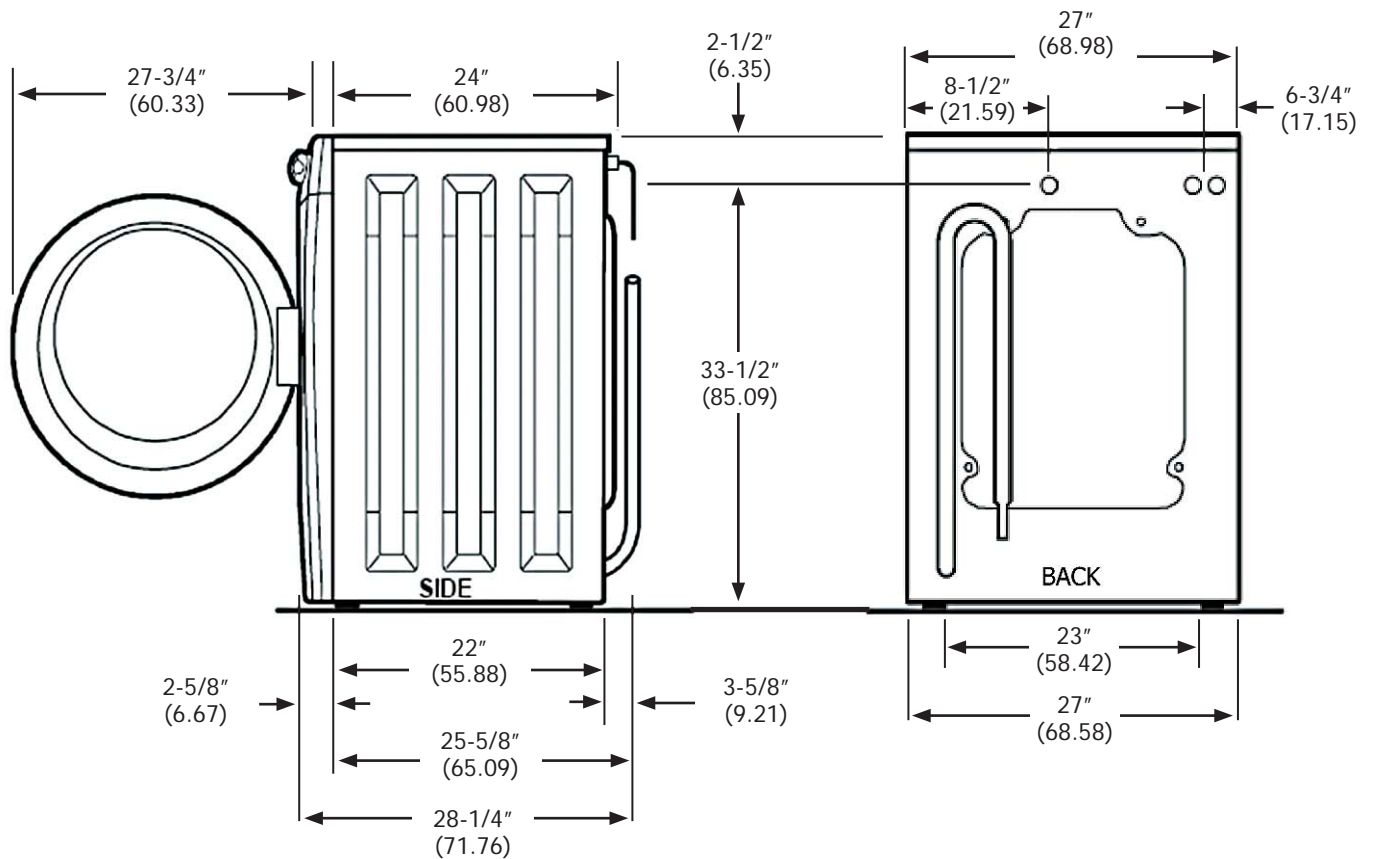

Figure 2-2. Unit Dimensions

NOTE

A pedestal accessory, Model No. APWD15W, specifically designed for this washer may be used when elevating the washer for ease of use. Failure to use accessories certified by the manufacturer could result in personal injury, property damage or damage to the washer.

Section 2 Installation Information

Water Supply Requirements

Hot and cold water faucets **MUST** be installed within 42 inches (107 cm) of the washer's water inlet. The faucets **MUST** be 3/4 inch (1.9 cm) with threading for laundry hose connection. Water pressure **MUST** be between 30 and 120 psi. Pressure difference between hot and cold cannot be more than 10 psi. The local water department can advise the customer of line water pressure.

Drain System Requirements

1. Drain capable of eliminating 17 gals (64.3 L) per minute.
2. A standpipe diameter of 1-1/4 in. (3.18 cm) minimum.
3. The standpipe height above the floor should be:
Minimum height: 24 in. (61 cm)
Maximum height: 96 in. (244 cm)

NOTE

Drain hose attached to washer can reach a 90 inch (229 cm) high standpipe. For higher standpipe, use hose P/N 134369410, available from an authorized parts distributor.

Unpacking Unit

1. Temporarily remove door tape.
2. Open washer door and remove everything from drum.
3. Close door and reapply door tape.
4. Using a rug, blanket or piece of cardboard to protect the floor, carefully lay washer on its back.
5. Remove styrofoam base and shipping plug and set them aside.
6. Carefully return washer to an upright position.
7. Carefully move the washer to within 4 feet (1.3 m) of its final location.
8. Remove the following from back panel of washer:
4 shipping bolts, 4 spacers and 2 metal "P" clamps.
9. Remove the 4 plugs from the literature pack located in the drum and install them in the holes vacated by the packing spacers.

CAUTION

EXCESSIVE WEIGHT HAZARD

To avoid back or other injury, have more than one person move or lift the washer.

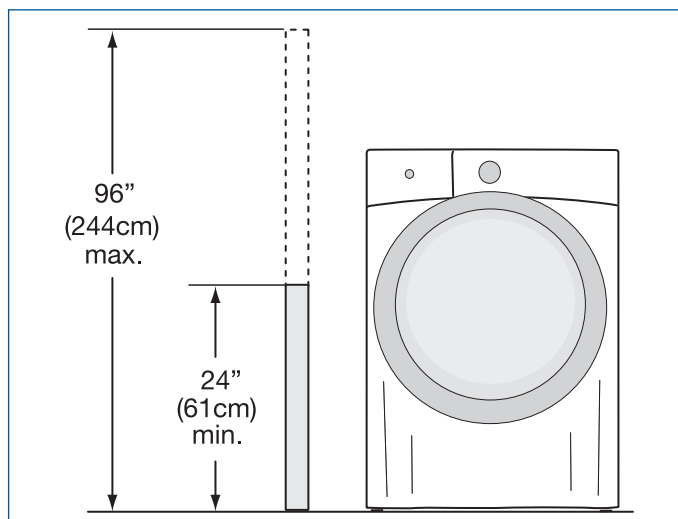

Figure 2-3. Standpipe Dimensions

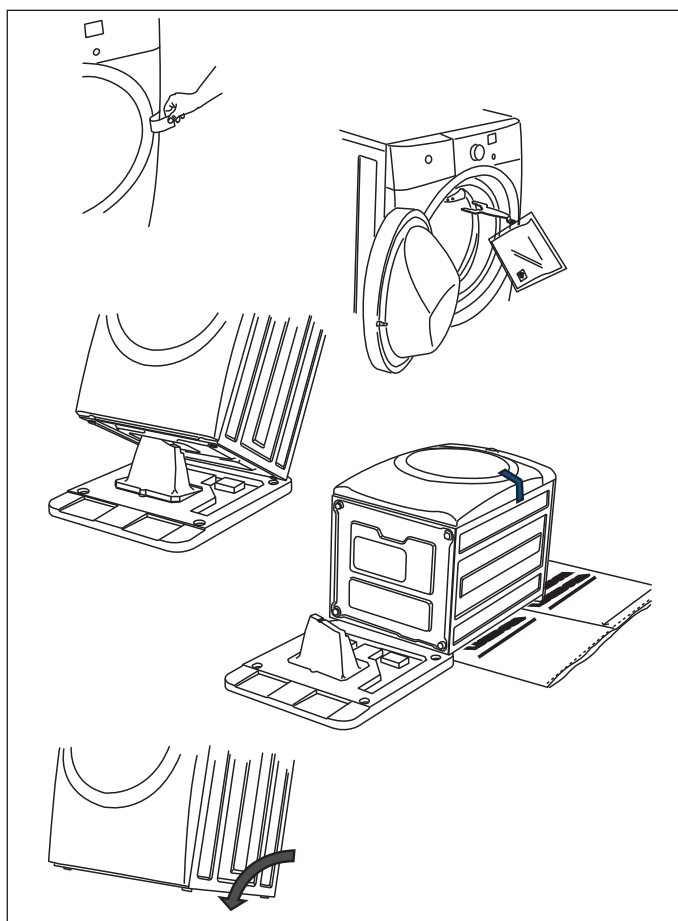

Figure 2-4. Unpacking Unit

NOTE

If the washer is to be transported at a later date, the shipping support hardware must be reinstalled to prevent shipping damage.

Section 2 Installation Information

Clearance Requirements Installation in a Recess or Closet

➔ IMPORTANT

DO NOT INSTALL THE WASHER:

1. In an area exposed to dripping water or outside weather conditions. The ambient temperature should never be below 60° F (15.6° C) to maximize detergent effectiveness.
2. In an area (garage or garage-type building) where gasoline or other flammables (including automobiles) are kept or stored, or an area where it will come in contact with curtains or drapes.
3. Floor **MUST** be solid with a maximum slope of 1 inch (2.54 cm). To minimize vibration or movement, reinforcement of the floor.

If washer and dryer are installed in the same closet, door ventilation is required: A minimum of 120 square inches (774.2 cm²) of opening, equally divided at the top and bottom of the door, is required. Louvered openings should be located 3 inches (7.6 cm) from bottom and top of door. Air openings are required to be unobstructed when a door is installed. A louvered door with equivalent air openings for the full length of door is acceptable.

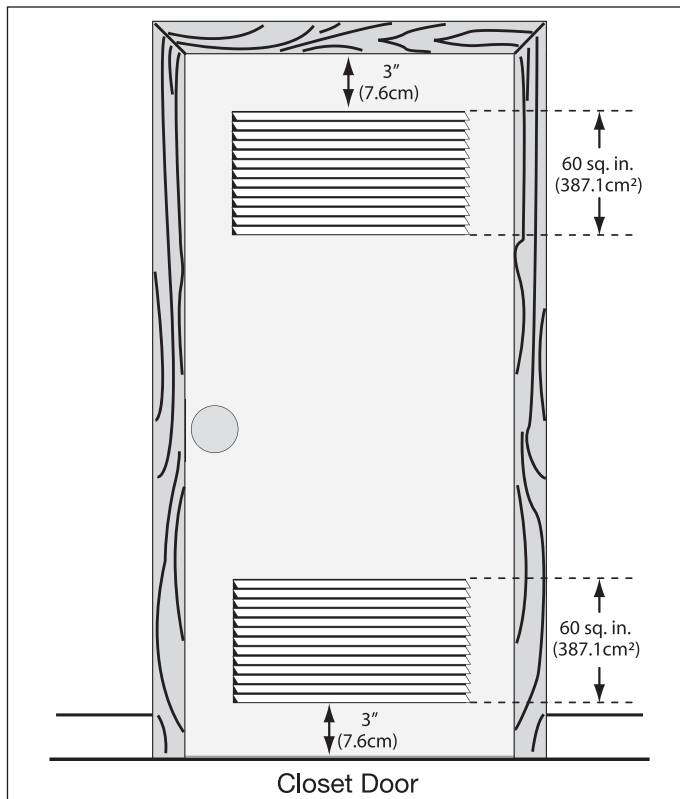

Figure 2-5. Closet Installation

MINIMUM INSTALLATION CLEARANCES - Inches (cm)				
	SIDES	REAR	TOP	FRONT
Alcove	0" (0 cm)	0"(0 cm)*	0" (0 cm)	n/a
Under-Counter	0" (0 cm)	0"(0 cm)*	0" (0 cm)	n/a
Closet	0" (0 cm)	0"(0 cm)*	0" (0 cm)	1" (2.54 cm)

* For other than straight back venting, a quick-turn 90° dryer vent elbow (vented right or down in free-standing dryer or right on pedestal-mounted dryer) must be installed to achieve 0" (0 cm) installation.

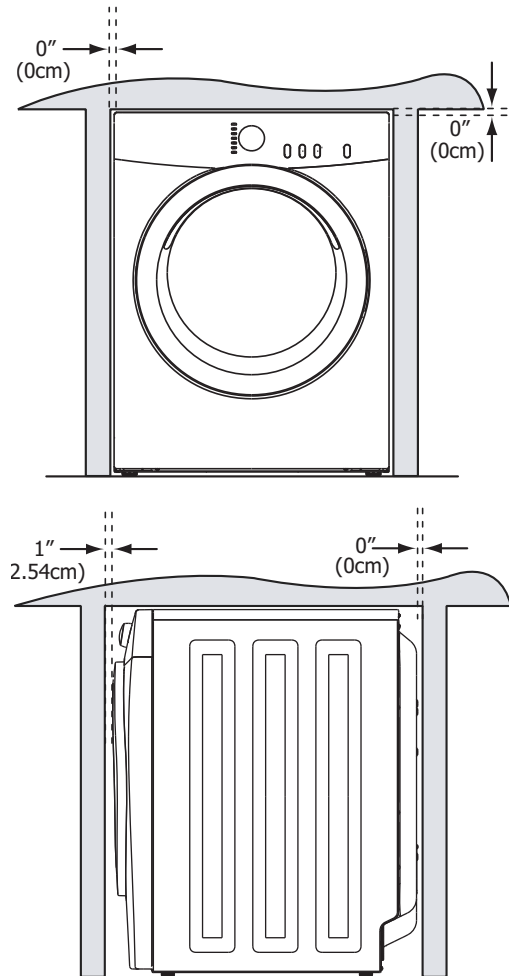

Figure 2-6. Clearances

Section 2 Installation Information

Leveling Washer

Excessive noise and vibration can be prevented by properly leveling the washer.

1. For free standing installation and with the washer in its final position, place a level on top of the washer. Adjust the leveling legs so the washer is level front-to-rear and side-to-side, and stable corner-to-corner. Press down on alternate corners and sides and feel for the slightest movement. Adjust the appropriate leg so the washer is SOLID on the floor on ALL four legs. Keep the leveling leg extension at a minimum for best performance of the washer.
2. For pedestal installations, See additional installation instructions included with the pedestal.

NOTE

For pedestal installations, see additional installation instructions included with the pedestal.

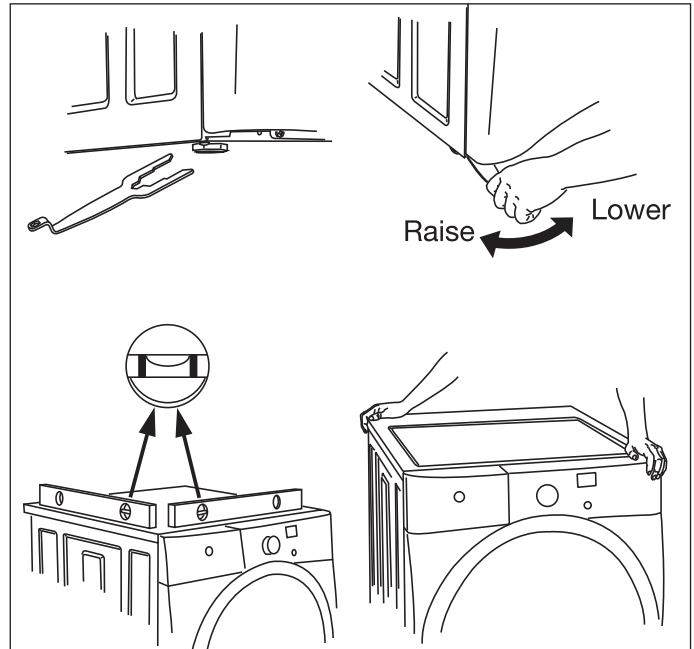

Figure 2-7. Leveling Washer

Connecting Inlet Water

1. Run some water from the hot and cold faucets to flush the water lines and remove particles that might clog the water valve screens and to determine which faucet is hot and which is cold supply.
2. Remove the inlet hoses and rubber washers from the plastic bag located in the drum of the washer and install the rubber washers in each end of the inlet hoses.
3. Carefully connect the inlet hose marked "HOT" to the outside "H" outlet of the water valve. Tighten by hand, then tighten another 2/3 turn with pliers. Carefully connect the other inlet hose to the inside "C" outlet of the water valve. Tighten by hand, then tighten another 2/3 turn with pliers. Do not cross thread or overtighten these connections.
4. Connect the inlet hose ends to the HOT and COLD water faucets tightly by hand, then tighten another 2/3 turn with pliers. Turn the water on and check for leaks.
5. Turn on the water and check for leaks.

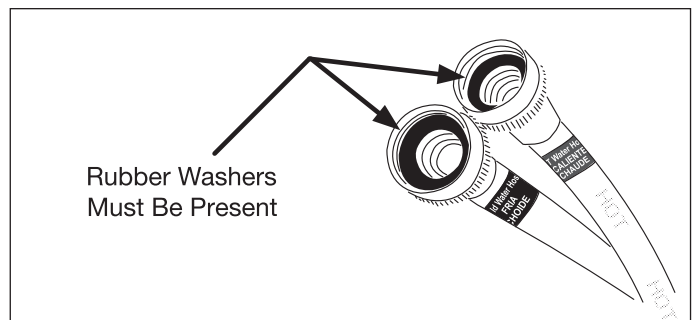

Figure 2-8. Connecting Inlet Water

NOTE

Use only new hoses.

Section 2 Installation Information

Connecting Drain and Electrical

1. Snap one end of the drain hose hanger (shipped in washer drum) onto the drain hose. Continue wrapping it around the hanger and snap it in place.
2. Place the hook end of the drain hose in the drain opening. Secure the drain hose with the cable tie (provided in the enclosure package) to the stand-pipe, inlet hose, laundry tub, etc. so the hose does not pull out from the force of the water.
3. Plug the power cord into a grounded outlet.
4. Turn on the power at a circuit breaker/fuse box.
5. Carefully slide the washer to its final position. Recheck for level and rock corners for stability. Remove and discard door tape.

NOTE

A wiring diagram and technical data sheet are located under the washer top panel, on top of the detergent dispenser housing.

Installation Checklist

Doors

- Handles are secure and tight
- Door seals completely to cabinet on all sides

Leveling

- Washer is level, side-to-side and front-to-back
- Cabinet is setting solid on all corners

Electrical Power

- House power turned on
- Washer plugged in

Water Connections

- House water supply turned on
- Check for leaks at all connection points

Final Checks

- Shipping material removed
- Run washer through a cycle check for proper operation
- Registration card sent in

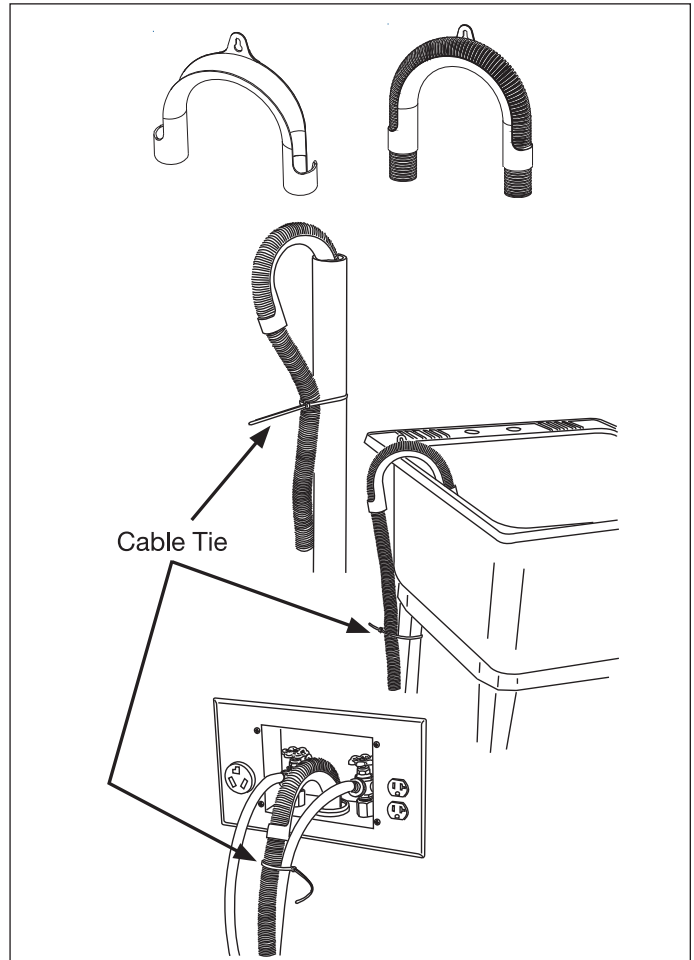

Figure 2-9. Drain Hose Installation

Section 2 Installation Information

Washer and Dryer 15" Drawer Pedestal Installation

The Affinity Series washers and dryers use the same pedestal.

Tools needed:

- Level
- 9/16" open end wrench
- #2 Phillips screwdriver
- Washer/Dryer Installation Kit

NOTE

This kit is intended to be installed by persons having electrical and mechanical training and a level of knowledge considered acceptable in the appliance repair trade.

Pedestal Installation

1. Attach the rear brackets to the pedestal with (4)- #10 screws (2 per bracket). (See Figure 2-9)
2. Attach the front brackets and spacer plates to the pedestal with (4)- #10 screws (2 per bracket).
3. Tilting the dryer back slightly to engage the slots in the rear of the dryer with the tabs of the rear brackets on the pedestal.

NOTE

If washer was previously installed, disconnect power cord, remove the inlet hoses from the water faucets and tape the drain hose to the top of the washer to eliminate excess water on the floor.

4. Using two or more people, carefully lift the washer onto the pedestal, tilting the washer back slightly to align the holes in the rear of the washer with the slots of the rear brackets on the pedestals.

NOTE

If the mounting holes do not align, make sure washer leveling legs are adjusted fully into washing machine. Turn each leg tight to the base.

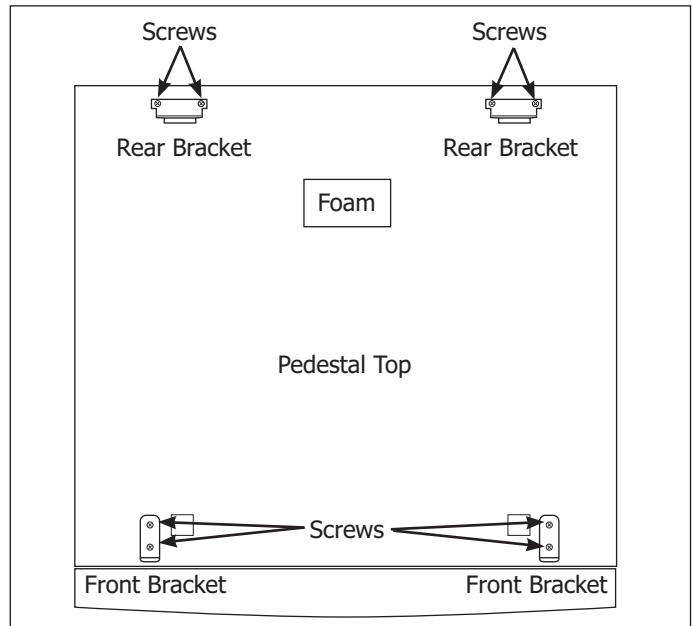

Figure 2-9.

NOTE

Do not remove the foam in the middle of the pedestal. It reduces vibration noise.

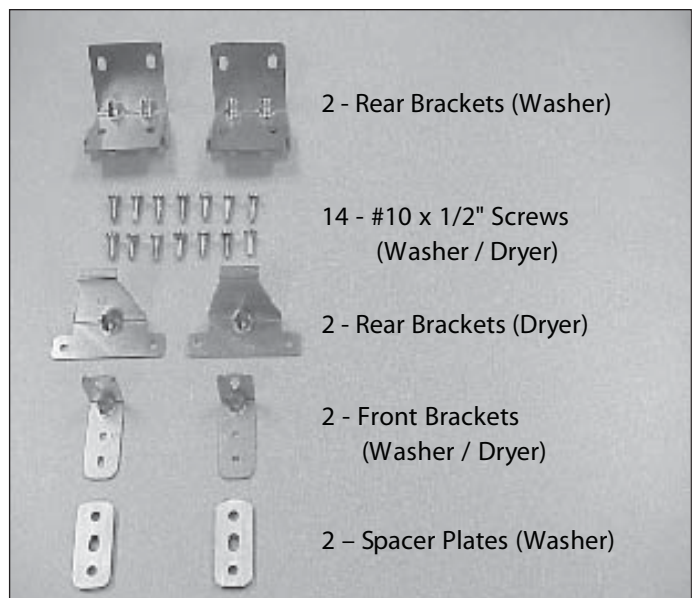

Figure 2-10. Kit Components

Section 2 Installation Information

Pedestal Installation

5. Set the washer down onto the pedestal making sure the washer base is behind the front brackets of the pedestal.
6. Align the sides of the washer with the sides of the pedestal and attach the washer to the rear brackets using four #10 screws (2 per bracket) as shown in Figure 2-11.
7. With pedestal drawer open for better access, install the two #10 screws through the front brackets in the pedestal into the washer base as shown in Figure 2-12.
8. After closing the pedestal drawer, carefully move the washer/pedestal assembly into position.

NOTE

Because of the increased weight caused by the addition of the pedestal, two or more people may be required.

9. Excessive noise and vibration can be prevented by properly leveling the washer/pedestal assembly on a SOLID floor and tightening the leveling leg lock nuts. With washer/pedestal assembly in its final position, place a level on top of washer. Adjust pedestal leveling legs so the washer/pedestal assembly is level front-to-rear and side-to-side, and stable corner-to-corner.
Press down on alternate corners and sides and feel for the slightest movement. Adjust the appropriate leg so the washer/pedestal assembly is SOLID on the floor on ALL four pedestal legs. After leveling the washer/pedestal assembly, adjust the lock nut on each pedestal leveling leg against the pedestal base and tighten with a wrench. Keep the leg extension at a minimum to prevent excessive vibration.
10. Complete the installation following the procedures at the beginning of this section.

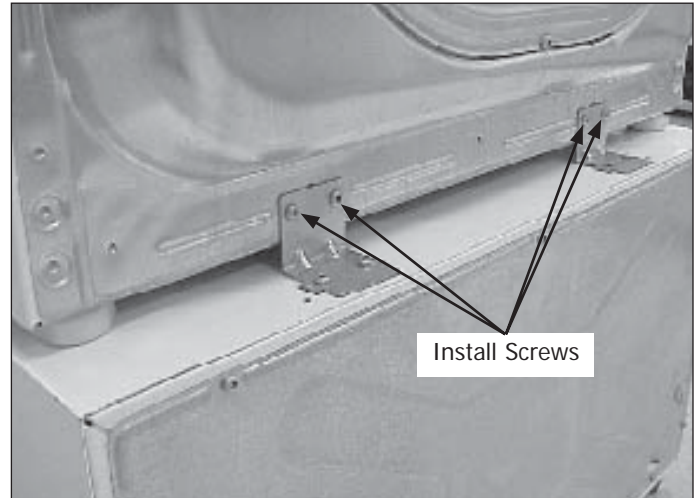

Figure 2-11.

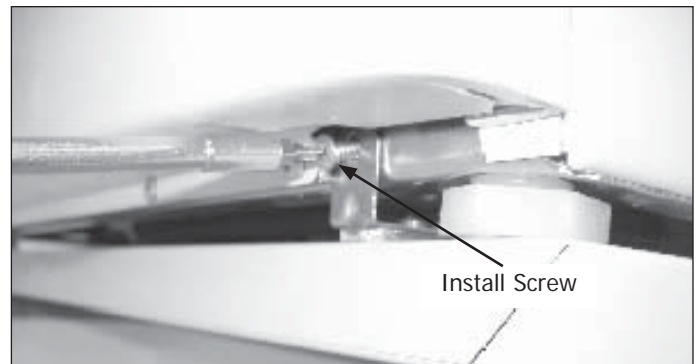

Figure 2-12 .

Affinity Series Control Panel Layout

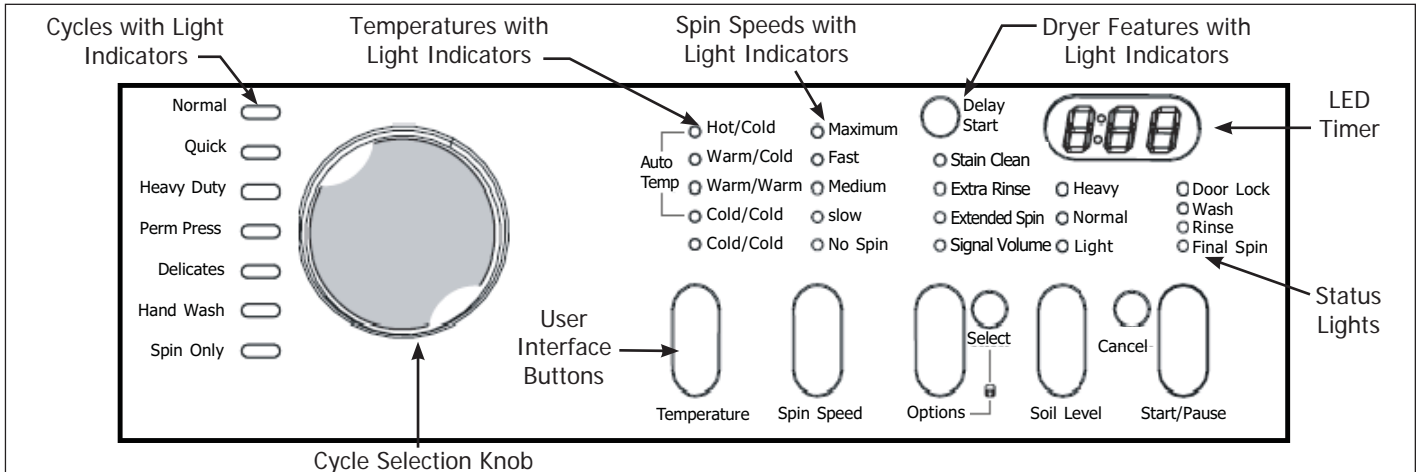

Figure 3-1. Affinity 6000 Series Control Panel

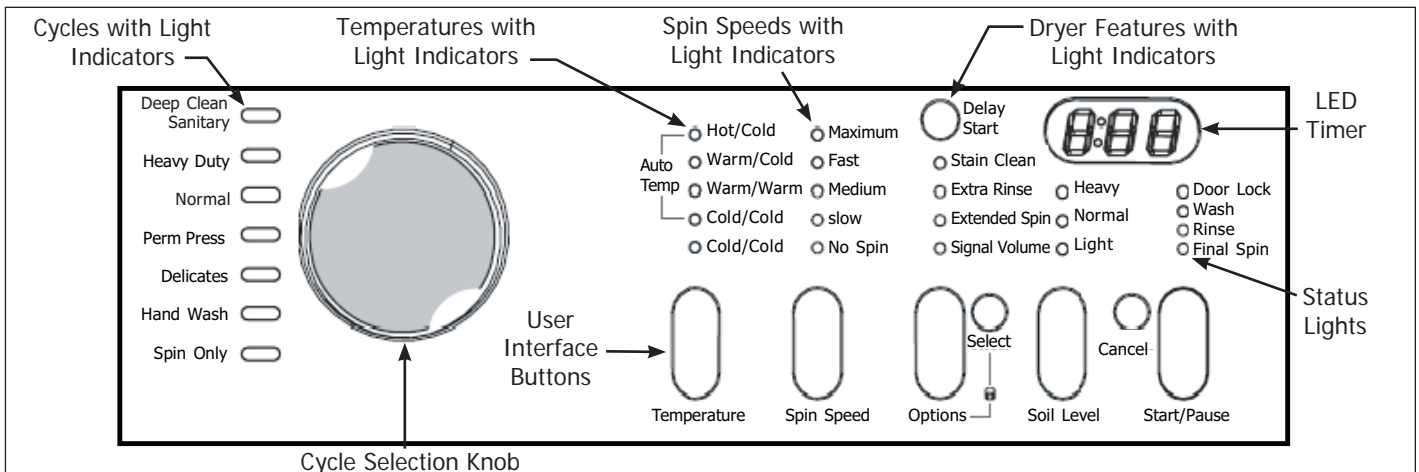

Figure 3-2. Affinity 7000 Series Control Panel

! WARNING

To reduce the risk of fire, electric shock or injury to persons, read and be knowledgeable of the IMPORTANT SAFETY INSTRUCTIONS in the washer Owner's Guide before operating this appliance.

Section 3 Electronic Control

Affinity Series Control Panel Layout

Operating Steps

1. Prepare items for washing.
2. Pretreat stains and heavy soil.
3. Add laundry load to the wash drum.
4. Add laundry products to the dispenser.
 - Detergent, bleach and fabric softener will be dispensed at the proper time in the cycle.
 - Slide safety latch to the right to open the dispenser drawer.
 - Add the recommended amount of a high efficiency detergent to the detergent compartment.
 - If desired, add liquid chlorine bleach and liquid fabric softener to the appropriate compartments.
 - Slowly close dispenser drawer.
 - Any water remaining in dispenser at end of cycle is a result of siphoning action and part of normal operation.
5. Select appropriate cycle and settings for the load.
 - Turn the Cycle Selector knob in either direction to select cycle. Estimated cycle time will be displayed.
 - Suitable wash and rinse water temperatures, final spin speed, options and soil level for each cycle will automatically be displayed. See the Cycle Selection Chart for more details.
 - To change the settings, press the Temperature, Spin Speed and Soil Level buttons.
 - To select or delete an option, press Options, then while the indicator is blinking, press Select. The indicator will light when option has been selected. It will no longer be lit when the option has been deleted.
 - To provide the best care for your laundry, not every setting or option is available with every cycle. If a setting or option is not available, its indicator will not light.
 - Adjustments to the cycle will be remembered each time that cycle is selected in the future. To return to the factory settings, press Start/Pause and Select at the same time and hold until a signal sounds.
6. Select Delay Start to delay the beginning of the cycle for up to 14 hours, if desired.
7. Start the washer.
 - Close the door and press Start/Pause. The washer will not operate with the door open. The status lights will blink, the signal will beep and "dr" will be displayed as a reminder to close the door.

- As a safety measure, the door will automatically lock during the entire wash cycle and the Door Lock indicator will be lit.
 - To add a forgotten item to the wash drum, press Start/Pause, open the door, add the item, close the door and press Start/Pause to resume the cycle. "PAU" will be displayed alternately with the estimated cycle time.
 - If the cycle is interrupted during spin, it will take approximately 2-3 minutes for the door lock to release. DO NOT force open the door.
 - To stop the washer, press Cancel.
8. A signal will sound when Signal option is selected.
 9. Remove items from washer when the cycle ends.

Cycle Selection

Turn the Cycle Selector knob to the desired cycle. For best results, follow the fabric care label instructions on items to be washed. To change the selection after the cycle has begun, press Cancel before making another choice. Just turning the knob to another selection will not change the cycle.

Cycle Description

Deep Clean Sanitary

Use the Deep Clean cycle for heavily soiled colorfast items that should be washed in very hot water. Only the Hot/Cold Temperature setting is available. The household water heater should be set at a minimum of 120° F. If the setting is lower, the cycle time will be extended by 30 minutes or more.

The wash water is heated by an internal boost heater to a maximum of 152° F as the load tumbles for up to 90 minutes. "SA" is displayed during the wash phase alternately with the estimated cycle time. Cold water is added to Cool Down the load prior to drain and **spin**. This cycle will eliminate 99.999% of 4 common infectious bacteria*. (If the cycle is interrupted while the water is heating, the final temperature of the wash water may be lower and sanitation may be reduced.)

Heavy Duty

The Heavy Duty cycle provides 20 minutes of reversing tumble wash action for heavily soiled sturdy items. Hot water is recommended to remove heavy soil and most stains. Stain Clean, Extra Rinse and Extended Spin are available options.

Normal

The Normal cycle provides 15 minutes of reversing tumble wash action for normally soiled loads. Stain Clean, Extra Rinse and Extended Spin are available options.

Perm Press

The Perm Press cycle provides 10 minutes of reversing tumble wash action for cottons and blends with a no-iron finish. To minimize wrinkling, the Warm Rinse and Extended Spin option are not available with this cycle. The Stain Clean and Extra Rinse options can be selected.

Quick

The Quick Cycle provides 10 minutes of reversing tumble wash action for lightly soiled items that must be laundered quickly. To save time, the Extra Rinse and the Extended Spin option are not available with this cycle.

Delicates

This cycle provides 10 minutes of gentle reversing wash action for knits and delicates. To protect your delicate items, a hot water wash, Heavy Soil, and the Extended Spin option are not available. The Stain Clean and Extra Rinse options are available.

Hand Wash

Select the Hand Wash cycle for items labeled "Hand Washable". Ten minutes of occasional tumbling are followed by 3 rinses and a slow final spin. To protect your hand, a hot water wash, Heavy Soil, the Clean Stain and Extended Spin options are not available. The Extra Rinse option is available.

Spin Only

Use the Spin Only cycle anytime you want to drain water from the washer and spin out the load or as a follow-up to a No Spin selection. Select the spin speed appropriate to the load. To add a rinse prior to spin, select the Extra Rinse option.

Cycle Settings

Appropriate wash and rinse water temperatures, final spin speed and soil level settings for each cycle will automatically be displayed when a cycle is selected. To change the preset selections, press Temperature, Spin Speed and Soil level to scroll to the desired setting. If a setting is not appropriate for that cycle, the indicator will not light up.

NOTE

Pressing any button during operation of the cycle will produce flashing indicator lights, beeping and "Err" will be displayed. To change a setting after the cycle starts, press the START/PAUSE before making adjustment. Changes made to the cycle will automatically be remembered each time that cycle is selected in the future.

Wash / Rinse Water Temperatures

Select a wash water temperature according to fiber content, colorfastness and soil level. For best results, follow the care label instructions and use the hottest water safe for the fabric. A cold water rinse saves energy and reduces wrinkling.

- Hot/Cold Heavily soiled white/colorfast cotton and perm press loads.
- Warm/Cold Normally soiled white/colorfast cotton and perm press loads.
- Warm/Warm Washable woolsens.
- Cold/Cold Lightly soiled non-colorfast items, knits, delicates and hand washables.

Auto Temp

Auto Temp improves washing performance. Water temperature can be affected by the water heater setting and its distance from the washer, water usage in other parts of the home and seasonally low ground water temperatures in some geographic areas. Because most detergents work best in wash water at a minimum of 65°F, select Auto Temp settings for regulated wash and final rinse water temperatures.

Auto Temp Hot 120° F

(Only if water heater temperature is greater than 120° F.)

Auto Temp Warm ... 90° F

Auto Temp Cold 65° F

Cold Temperature of cold tap water.

Section 3 Electronic Control

Spin Speed

Maximum, Fast, Medium and Slow speeds are available for each cycle. The final spin speed and duration vary from cycle to cycle.

- Increasing spin speed will extract more water and decrease drying time.
- Decreasing spin speed will reduce wrinkling.
- Select Slow spin speed to gently spin items that should be line dried.
- Use No Spin to omit the final spin at the end of the cycle. The load will be very wet. Remove items from the wash drum to drip dry or select Spin Only to remove excess water at a more convenient time.

Soil Level

Press Soil Level to increase or decrease the wash time.

Water Level

There is no need to select a water level. The washer automatically adjusts the water level to the type and size of wash load.

Cycle Options

To select or delete the Extra Rinse, Extended Spin or Signal Volume, press Options until the blinking light indicates the desired option. Then, while it is blinking, press Select. The indicator will light when the option has been selected. It will no longer be illuminated when the option has been deleted. To provide the best care for your laundry items, not every option is available with every cycle.

Stain Clean

Use the Stain Clean option to add a 5-minute soak in the middle of the wash portion of any cycle except Quick and Hand Wash.

Extra Rinse

Use this option when additional rinsing is desired to remove excess dirt and detergent. It is recommended for heavily soiled loads or if household members have sensitive skin. Extra Rinse occurs before the final rinse when the liquid fabric softener is dispensed.

Extended Spin

Use this option to add several additional minutes to the final spin at the selected speed. This will improve water extraction and decrease drying time.

Signal Volume

A signal will sound at the end of the cycle this option is selected. The signal has an adjustable volume level or can be turned off.

Washer Features

Delay Start

Press Delay Start to select a wash time convenient to your schedule or during off peak energy hours. The start of the cycle can be delayed for up to 14 hours. The delay time selected will be displayed as 30, 60 or 90 minutes or 2 through 14 hours.

Control Lock

To avoid having someone accidentally start or stop the washer, press Options and Select at the same time and hold for 10 seconds until "LOC" is displayed alternately with the estimated cycle time. To unlock the controls, press Options and Select at the same time and hold 10 seconds until "LOC" is no longer displayed.

Estimated Cycle Time

The estimated total cycle time will be displayed when the cycle is selected. The time may increase if water pressure is low, oversudsing occurs or the load becomes unbalanced. The approximate time remaining will be displayed during the cycle.

Status Lights

The following will be displayed at the appropriate times during the cycle:

- Door Lock
- Wash
- Rinse
- Final Spin

Start/Pause

Press Start/pause to start, pause or restart a cycle. "PAU" will be displayed alternately with the estimated time remaining when the cycle is paused.

Cancel

Press Cancel to stop the cycle.

Affinity 6000 Series Cycle Chart

Cycle Selection Chart

The following chart shows the temperature, spin speeds, soil level options, and the features available for each cycle.

Estimated Cycle Duration	Normal 45 minutes	Quick 33 minutes	Heavy Duty 48 minutes	Permanent Press 36 minutes	Delicates 35 minutes	Handwash 35 minutes	Spin Only 12 minutes
--------------------------	----------------------	---------------------	--------------------------	-------------------------------	-------------------------	------------------------	-------------------------

Temperatures

Auto Temp Hot/Cold	X	X	X	X			
Auto Temp Warm/ Cold	* X	* X	* X	* X	X	X	
Auto Temp Warm/Warm	X	X	X	X	X	X	
Auto Temp Cold/ Cold	X	X	X	X	* X	* X	
Tap Cold/Cold	X	X	X	X	X	X	

Spin Speed

Maximum	* X	* X	* X	X	X	X	* X
Fast	X	X	X	* X	X	X	X
Medium	X	X	X	X	* X	X	X
Slow	X	X	X	X	X	* X	X
No Spin	X	X	X	X	X	X	X

Soil Level

Heavy Soil	X	X		X			
Normal Soil	* X	* X	* X	* X	* X	* X	
Light Soil	X	X	X		X	X	

Options & Features

Stain Clean	X		X	X	X		
Extra Rinse	X		X	X	X	X	X
Extended Spin	X		X				
Signal	* X	* X	* X	* X	* X	* X	* X
Delay Start	X	X	X	X	X	X	X

* Factory Settings

X Available settings

**Estimated cycle duration is based on factory settings and does not include water fill times, out of balance, oversudsing condition or spin speed selected.

Section 3 Electronic Control

Affinity 7000 Series Cycle Chart

Cycle Selection Chart

The following chart shows the temperature, spin speeds, soil level options, and the features available for each cycle.

Estimated Cycle Duration**	Deep Clean Sanitary	Normal	Heavy Duty	Perm Press	Delicates	Handwash	Spin Only
1hr. 50 min		45 minutes	48 minutes	36 minutes	35 minutes	33 minutes	12 minutes

Temperatures

Auto Temp Hot/Cold	*X	X	X	X			
Auto Temp Warm/Cold		*X	*X	*X	X	X	X
Auto Temp Warm/Warm		X	X		X	X	
Auto Temp Cold/Cold		X	X	X	*X	*X	*X
Tap Cold/Cold		X	X	X	X	X	X

Spin Speed

Maximum	*X	*X	*X	X	X	X	*X
Fast	X	X	X	*X	X	X	X
Medium	X	X	X	X	*X	*X	X
Slow	X	X	X	X	X	*X	X
No Spin	X	X	X	X	X	X	X

Soil Level

Heavy Soil	X	X	X	X			
Normal Soil	*X	*X	*X	*X	*X	*X	*X
Light Soil		X		X	X	X	X

Options & Features

Stain Clean		X	X	X	X	X	
Extra Rinse	X	X	X	X	X	X	X
Extended Spin	X	X	X	X			
Signal	*X	*X	*X	*X	*X	*X	*X
Delay Start	X	X	X	X	X	X	X

* Factory Settings

X Available settings

** Estimated cycle duration is based on factory settings and does not include water fill times, out of balance, oversudsing condition or spin speed selected.

Error Codes

The electronic control has self diagnostics error codes built in that cover most products failures.

Reading Error Codes

1. Wake the washer by pressing any button.
2. Wait 5 seconds.
3. Press and hold the START/PAUSE and CANCEL buttons simultaneously. As long as the buttons are held, the failure code will appear in the display as an "E" followed by two numbers, a number and a letter or two letters. The control will beep and the Door Lock, Wash, Rinse, and Final Spin indicator lights will flash.

Quick Check

If there is no error displayed and washer momentarily starts then turns back off:

1. Listen for a relay closure inside the motor control shortly after the START/PAUSE key is pressed. If this happens, the motor control has power.
2. Check the 5 pin connector wiring between the console control and the motor control.

NOTE

During normal operation, the display may show:

- "SAn" - deep clean (Sanitary Cycle)
- "cd" - cool down (Sanitary cycle)
- "do" or "dr" - door problem.
- "Err" - an error has been detected.
- "LOC" - control lock is activated.
- "PAU" - cycle has been interrupted.

To Clear Latest Stored Error Code

- Turn the Program Knob to start position, Spin Only.
- Press START/PAUSE to start the cycle and save it.
- Press CANCEL to stop the cycle and turn off LEDs.
- Press CANCEL again to turn on the LEDs.
- Within 5 seconds, press and hold the OPTION and START/PAUSE buttons until LEDs start sequentially chasing, then release buttons.
- Turn program knob clockwise 7 clicks from Start Position. The control will signal the last error code.
- Press and hold the OPTIONS and START/PAUSE buttons for 3 seconds. The code will be cleared.
- Exit Diagnostic Mode to return the washer to normal operation.
 - a) Unplug the power cord, wait 5-8 seconds, then reconnect the power cord OR
 - b) Turn the program knob clockwise 2 or 3 clicks after the Start Position. Press OPTIONS and START/PAUSE buttons together for a few seconds until wash cycle LEDs appear.

To clear latest stored error code:

- Turn the Program Knob to start position, Spin Only.
- Press START/PAUSE to start the cycle and save it.
- Press CANCEL to stop the cycle and turn off LEDs.
- Press CANCEL again to turn on the LEDs.
- Within 5 seconds, press and hold the OPTION and START/PAUSE buttons until LEDs start sequentially chasing, then release buttons.

Section 3 Electronic Control

Diagnostic Test

The diagnostic test is used to check individual washer component function only.

To Start The Test:

- Turn Program Knob to the start position, Spin Only.
 - Press START/PAUSE to start the cycle and save it.
 - Press CANCEL to stop the cycle and turn off LEDs.
 - Press CANCEL again to turn on the LEDs.
 - Within 5 seconds, press and hold the OPTIONS and START/PAUSE buttons until LEDs start sequentially chasing, then release buttons.
1. All the LEDs will sequentially light. Pressing a button below a light cluster will light all the LEDs in that cluster at one time to confirm functionality.
 2. Turn the program knob (1) click clockwise from the start position. The hot water solenoid will activate and hot water should enter through the detergent compartment.
 3. Turn the program knob (2) clicks from the start position. The bleach water solenoid will activate and cold water should enter through the bleach compartment.
 4. Turn the program knob (3) clicks from the start position. The bleach and the wash water solenoids will activate and cold water should enter through the softener compartment.
 5. Turn the program knob (4) clicks from the start position. The door lock solenoid will deactivate and the loading door can be opened. When the door is opened, the drum light should turn on.
 6. Turn the program knob (5) clicks from the start position. The washer will fill and tumble. Once tumbling has started, the Boost Heater (if so equipped) will turn on.
 7. Turn the program knob (6) clicks from the start position. The drain pump & door lock solenoid will activate and the washer will operate in high spin.



WARNING

If power is removed during this test, the door can be opened. To prevent injury, DO NOT put your hands inside when the tub is rotating.

8. Turn the program knob (7) clicks from the start position. The control will signal the last error code.

Exiting Diagnostic Mode

There are two options for exiting the Diagnostic Test mode and returning the washer to normal operation:

- a) Unplug the power cord, wait 5-8 seconds, then reconnect the power cord OR
- b) Turn the program knob clockwise 2 or 3 clicks after the start position. Press OPTIONS and START/PAUSE buttons together for a few seconds until wash cycle LEDs appear.

If a situation arises where you cannot exit the Diagnostic mode as described above, and the bank of 5 LED's on the right end remain ON regardless of Program Knob position, a combination of pushed buttons may have caused the control to enter a special factory test mode. If this occurs, disconnect power to reset the control to return washer to normal operation.

Drum Light Circuit Testing

To test the drum light circuit, remove the top of washer to gain access to terminals of the stepdown transformer.

With the washer door open, measure the voltage drop between the input terminals of the transformer.

If the meter reads zero, remove the door switch and check it with an Ohm meter. If the contacts are open with the plunger out, replace the door switch. If the contacts are closed, replace the control board.

If the meter reads line to neutral voltage, measure the voltage drop between the two output terminals. If the meter read zero the transformer is defective. If the meter reads 12 volts, the light is defective.



NOTE

Since it is recommended that the loading door be left open when the washer not in use, the electronic control board limits the amount of time the drum light is on. With the loading door open, the electronic control board allows power to the light for a maximum of (3) minutes.

If the drum light remains on for more than (3) minutes with the loading door opened, replace the electronic control board. If the drum light remains on with the loading door closed, replace the light switch.

Failure code chart		
Failure code	Fault condition	Check
E11	Fill time to long.	Refer to test (1).
E13	Water leak in tub or air leak in air bell.	Refer to test (2).
E21	Water not pumping out fast enough.	Refer to test (3).
E23	Drain pump relay on control board failed.	Replace control board or wire.
E24	Drain pump relay on control board failed.	Replace control board or wire.
E31	Pressure sensor not communicating with control board.	Refer to test (4).
E35	Pressure sensor indicates water overflow.	Refer to test (5).
E36	Control board problem.	Replace the control board.
E41	Control board thinks the door switch is open.	Refer to test (7).
E43	Board communications problem.	Replace the control board.
E44	Board communications problem.	Replace the control board.
E45	Board communications problem.	Replace the control board.
E46	Board communications problem.	Replace the control board.
E47	Board thinks the door PTC circuit is open in spin.	Refer to test (7)
E48	Board thinks the door PTC circuit is closed.	Refer to test (7)
E52	Bad signal from tachogenerator.	Refer to test (8)
E56	High motor current.	Refer to test (9)
E57	High current on inverter.	Refer to test (9)
E58	High current on motor phase.	Refer to test (9)
E59	No tacho signal for 3 seconds.	Refer to test (10)
E5A	High temperature on heat sink.	Test first if bad replace speed control board.
E5B	High temperature on heat sink.	Replace the speed control board.
E5C	High temperature on heat sink.	Replace the speed control board.
E5D	Communication problem.	Refer to test (11).
E5E	Communication problem.	Refer to test (11).
E5F	Communication problem.	Refer to test (11).
E66	Heating element relay failure.	Refer to test (14).
E67	Input voltage on microprocessor incorrect.	Refer to test (15).
E68	Current leakage to ground on heater or fuse opened.	Refer to test (14).
E74	Wash temperature does not increase.	Place NTC in correct position.
E75	Water temperature sensor circuit.	Refer to test (12)
E76	NTC temperature for the cold water valve over the limits.	Hot and cold water hoses switched.
E82	Console control problem	Replace the control board.
E83	Console control problem	Replace the control board.
E91	Selector LEDs do not light up	Refer to test (16)
E93	Console control problem	Replace the control board.
E94	Console control problem	Replace the control board.
E95	Communication error.	Replace the control board.

Section 3 Electronic Control

Failure code	Fault condition	Check
E97	Console control problem	Replace the control board.
E98	Console control problem	Replace the control board.
EB1	Incoming power frequency out of limits.	Refer to test (15)
EB2	Incoming line voltage above 130 VAC.	Check voltage at the outlet. If below 130 VAC replace the control board.
EB3	Incoming line voltage below 90 VAC.	Check voltage at the outlet. If above 90 VAC replace the control board.
EF1	Clogged drain pump.	Unclog the drain pump.
EF2	To much soap.	Advise customer to reduce the amount of soap they are using.
EBE	Console control problem	Replace the control board.
EBF	Console control problem	Replace the control board.
EF5	NTC temperature for hot water valve over the limits.	Hot and cold water hoses switched.

Section 3 Electronic Control

Tests		
Test	Check	Correction
Test 1:	1. Is the incoming water flow normal?	Yes. Go to step (4). No. Go to step (2)
	2. Are the incoming water faucets turned on?	No. Turn water faucets on. Yes. Go to step (3).
	3. Is the incoming water pressure above (30) psi?	No. Have customer correct pressure problem. Yes. Check for kinked or blocked incoming water hoses, clean the incoming water screens. If problem still remains replace the water inlet valve assembly.
	4. Does the fill water continue enter the washer?	Yes. Go to step (5). No. Go to step (6)
	5. Remove power from the washer. Did the water fill stop?	Yes. Go to step (6) No. Replace the inlet valve assembly.
	6. Check the electronic pressure sensor.	Pressure sensor checks good. Go to step (7). Pressure sensor checks bad. Replace pressure sensor.
	7. Replace the control board.	
Test 2:	1. Is the washer leaking water?	Yes. Correct water leak. No. Go to step (2)
	2. Is there an air leak in the air bell system?	Yes. Correct the air leak problem. No. Go to step (3)
	3. Check the electronic pressure sensor.	Defective. Replace the pressure sensor. Good. Go to step (4)
	4. Replace the control board.	
Test 3:	1. Check the drain hose for restrictions.	Restriction. Correct problem. No restriction. Go to step (2).
	2. Start the washer and check for 120 VAC at the drain pump.	Zero. Replace the control board. 120 VAC. Remove the pump and check it for blockage. If blocked, remove the restriction, if not replace the pump.
Test 4:	1. Inspect the wiring between the pressure sensor and the control board.	Defective wiring. Correct wiring. Good wiring. Replace the pressure sensor. If this does not correct the problem replace the control board.
Test 5:	1. Is the water level above 4.5 inches?	Yes. Go to step (2). No. Go to step (4).
	2. Does water enter the washer continuously?	Yes. Go to step (3). No. Replace the control board.
	3. Remove power from washer. Does the water stop coming in?	No. Replace water valve assembly. Yes. Check wiring to valve assembly for shorts. If wiring is good, replace the control board.
	4. Replace the pressure sensor switch. Did this correct the problem?	Yes. Problem solved. No. Replace the control board.

Section 3 Electronic Control

Test	Check	Correction
Test 6:	1. Is the loading door closed?	No. Close the door. Yes. Go the step (2).
	2. Disconnect the plug from J2 on the control board and check for continuity between the pins in the plug.	Open. Check the door strike. If good, replace the door switch assembly. Closed. Replace the control board.
Test 7:	1. Remove the door lock assembly and measure the resistance of the PTC.	Shorted or open. Defective door lock assembly. Around 1500 Ohms. Defective control board.
Test 8:	1. Disconnect the plug from the drive motor and measure the resistance pins 4 & 5 in the motor.	If the reading is between 105 & 130 Ohms, replace the speed control board. If the meter reads not than between 105 & 130 Ohms, replace the motor.
Test 9:	1. Remove the belt from the motor and spin the motor pulley. Does the motor spin free?	No. Replace the motor. Yes. Go to step (3)
	2. Spin the tub pulley. Does the tub spin free?	No. Check the tub bearings. Yes. Go to step (3)
	3. Disconnect the plug from the motor and measure the resistance of the windings. (pin 1 to pin 2, pin 1 to pin 3, pin 2 to pin 3) All reading should be between 4 and 6 Ohms.	If readings are correct, replace speed control board. If the readings are incorrect, replace the motor.
Test 10:	1. Remove the belt from the motor and spin the motor pulley. Does the motor spin free?	No. Replace the motor. Yes. Go to step (3)
	2. Spin the tub pulley. Does the tub spin free?	No. Check the tub bearings. Yes. Go to step (3)
	3. Disconnect the plug from the drive motor and measure the resistance pins 4 & 5 in the motor.	If the meter reads not other than between 105 & 130 Ohms, replace the motor. If reading is between 105 & 130 Ohms, go to step (4).
	4. Disconnect the plug from the motor and measure the resistance of the windings (pin 1 to 2, pin 1 to 3, pin 2 to 3). All readings should be between 4 and 6 Ohms.	If readings are correct, replace speed control board. If the readings are incorrect, replace the motor.
Test 11:	1. Communication problem. Check the wiring between the control board and the speed control board.	Wiring bad. Correct wiring problem. Wiring good. Replace the control board. If the problem is not corrected replace the speed control board.
Test 12:	1. Check the resistance of the NTC. Is it around 50K ohms?	No. Replace the water inlet valve assembly Yes Replace the control board.
Test 13:	1. Have the power company check the frequency of the incoming power. If correct replace the control board.	
Test 14:	1. Check the resistance of the heating element. It should be approximately 14 ohms.	If the readings are incorrect, replaced the heating element.
	2. Check the resistance between the ground and both heater terminals. It should be open when heater terminals are disconnected.	
Test 15:	1. Check the resistance of the tub in NTC. If Is it around 4.8 K Ohms?	No, replace the heater assembly. Yes, check the wiring.
Test 16:	1. Check the wiring harness between the control board & the interface board.	If defective, correct wiring problem. If the harness is good and none of the LEDs light, replace the interface board. If this does not correct the problem, replace the control board. Note: If only one of the LEDs will not light, replace the interface board

Jacks and Plugs

Control Panel

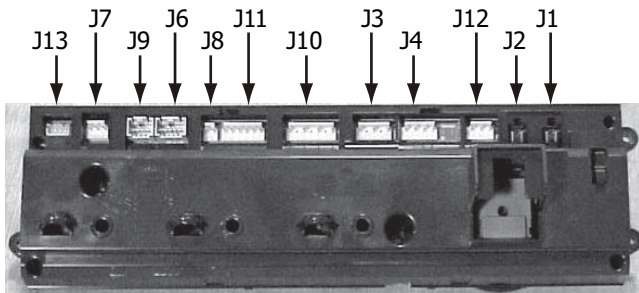

Control Board Circuits:

- J1 Power to the speed control board.
- J2 & J3 Door switch assembly circuits.
- J4, J9 & J12 Water inlet and drain pump circuits.
- J6 Codes to the speed control board.
- J7 Thermal sensor circuit. (Some models)
- J10 Drum light circuit.
- J13 Interface board.

Speed Control Board

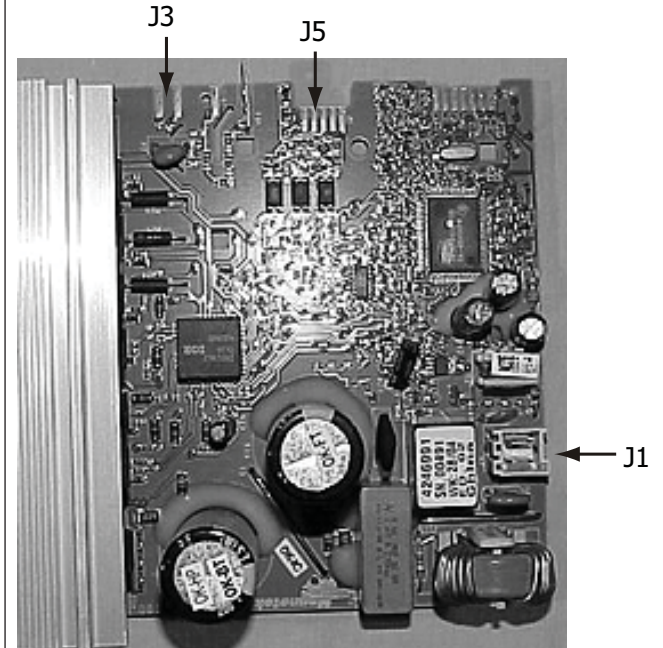

Speed control board circuits:

- J1 Line to neutral voltage from control board.
- J3 Code inputs from control board.
- J5 Outputs to the motor windings and tacho generator.

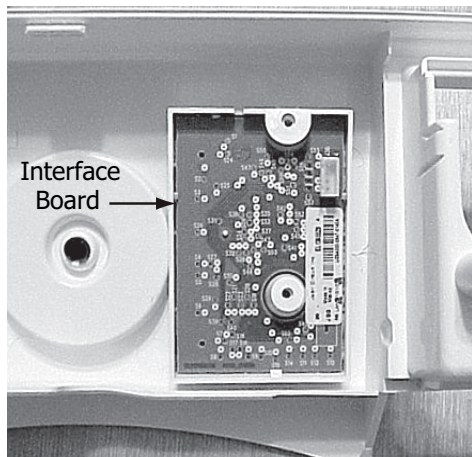
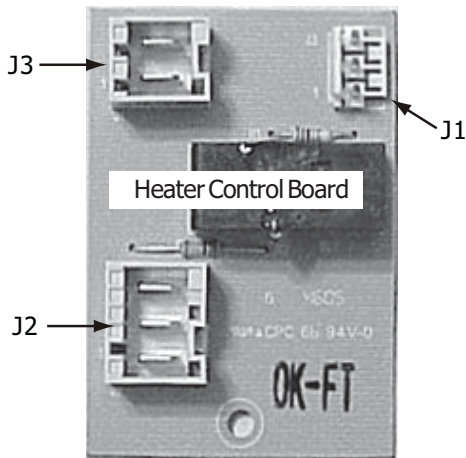

Motor Plug

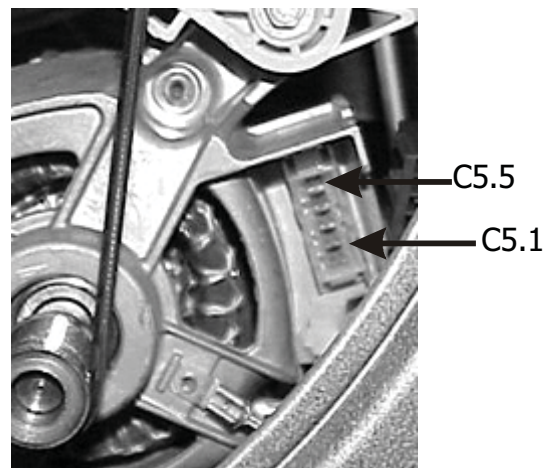

Motor Connections:

- C5.1, C5.2 & C5.3 Motor winding connections.
- C5.4 & C5.5 Tacho generator connections.

Section 3 Electronic Control

Operation speeds:								
Agitate Speed - RPM (Deep Clean Sanitary, Heavy, Normal, Quick, and Prem Pres) 47								
Agitate Speed - RPM (Hand Wash, Delicate, and Wool)..... 32								
Spin speeds	6000 Series Models				7000 Series Models			
Deep Clean Sanitary								
Heavy Duty, Normal & Quick	RPM	Sec.	RPM	Sec.	RPM	Sec.	RPM	Sec.
Spin Speed R.P.M. (Max)	1000	150	1050	240	1000	150	1100	240
Spin Speed R.P.M. (Fast)	1000	150	1050	210	1000	150	1100	210
Spin Speed R.P.M. (Medium)	1000	150	1020	180	1000	150	1100	180
Spin Speed R.P.M. (Slow)	1000	300			1000	300		
Perm Press								
Spin Speed R.P.M. (Max)	1000	90			1000	90		
Spin Speed R.P.M. (Fast)	1000	60			1000	60		
Spin Speed R.P.M. (Medium)	1000	45			1000	45		
Spin Speed R.P.M. (Slow)	1000	30			1000	30		
Delicate & Hand Wash								
Spin Speed R.P.M. (Max)	1000	40			1000	40		
Spin Speed R.P.M. (Fast)	1000	30			1000	30		
Spin Speed R.P.M. (Medium)	1000	15			1000	15		
Spin Speed R.P.M. (Slow)	1000	10			1000	10		
Spin Only								
Spin Speed R.P.M. (Max)	1000	150	1050	240	1000	150	1100	240
Spin Speed R.P.M. (Fast)	1000	150	1050	210	1000	150	1100	210
Spin Speed R.P.M. (Medium)	1000	150	1020	180	1000	150	1100	180
Spin Speed R.P.M. (Slow)	300				1000	300		

Component Teardown

This section explains how to access and remove components from a Frigidaire 6000 and 7000 Series Affinity Washer, and has been arranged in such a way as to simulate which components would need to be removed first in order to gain access to other components. When following a component removal procedure, it may be necessary to reference another component removal procedure listed earlier in this section.

IMPORTANT

Before continuing, please take note of the WARNINGS and CAUTIONS below.

WARNING

Before servicing or moving an appliance:

- Remove the power cord from the electrical outlet, trip the circuit breaker to the OFF position, or remove the fuse.
- Turn off the water supply for Washer.
- If it is necessary to remove a Washer unit from its installation, use proper lifting techniques as units are heavy and could fall resulting in serious injury or death. Pulling a unit from its installation should only be performed by a trained authorized service technician or installer.
- After service is completed, be sure all safety-grounding circuits are complete, all electrical connections are secure, and all access panels are in place.
- If unit was used prior to service, the heater assembly will be hot. Wear protective gloves and the appropriate safety gear when working with heating assemblies.
- If removing a door from a unit, remember that the doors are heavy. If they were to fall, they could cause serious personal injury.

CAUTION

- Metal edges may be sharp. Use caution and wear appropriate safety equipment when servicing dryers to avoid personal injury.
- If working in the motor area, remember that the heater element and tubing may be hot if used prior to service and during testing.

Section 4 Component Teardown

This section will describe how to access and remove serviceable components from the washer. Unless stated, the procedure will be the same on all models. Unless stated, reverse the procedure to reinstall the component.

Door Strike Removal

1. Open the loading door and extract the (2) screws holding the strike to the inner door liner. (See Figure 4-1)

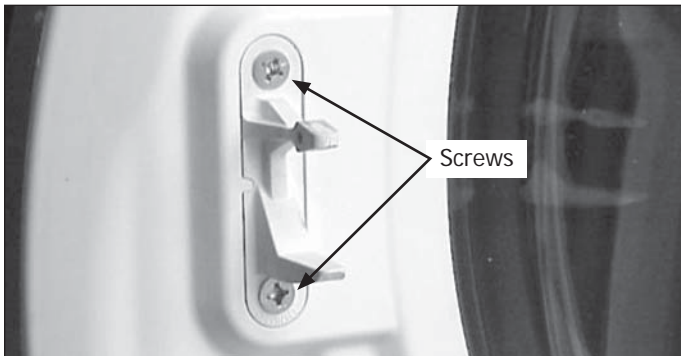

Figure 4-1.

Loading Door Removal

1. Extract the (3) screws securing the door hinge to the front panel. (See Figure 4-2)
2. Lift up and out on the door to disengage the hook on the hinge from the slot in the front panel. (See Figure 4-3)

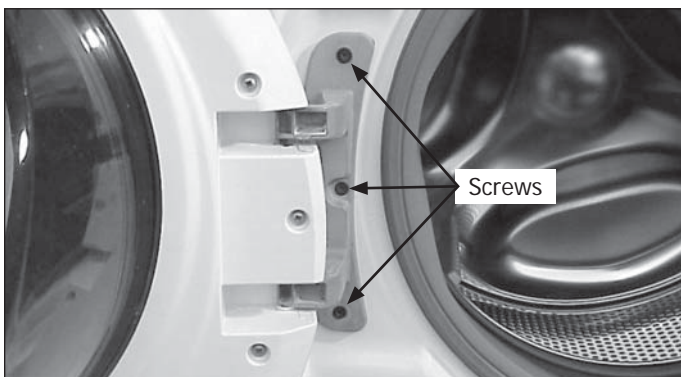

Figure 4-2.

Loading Door Breakdown

1. Remove the loading door from the washer and place it on a soft flat surface.
2. Remove the door strike and the (8) screws holding the inner liner to the outer liner and lift the inner liner off. (See Figure 4-4) (continued next page)



Figure 4-3.

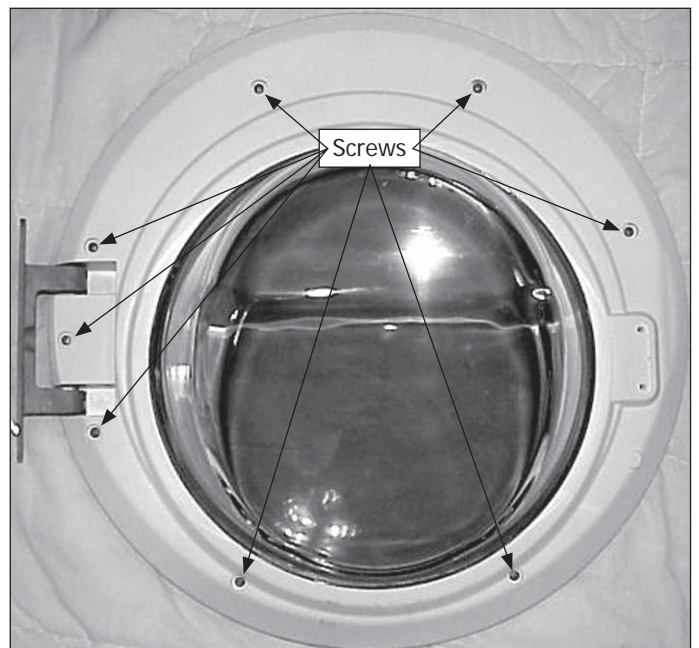

Figure 4-4.

Section 4 Component Teardown

Loading Door Breakdown (continued)

3. With inner liner removed, the door hinge lifts out. (See Figure 4-5)
4. With the inner liner removed, the inner glass lifts off.
5. The frame holding the outer lens to the outer liner is held in place by three tabs. Release the tabs and the frame will lift off. (See Figure 4-6)
6. With the frame removed, the inner lens will lift off.

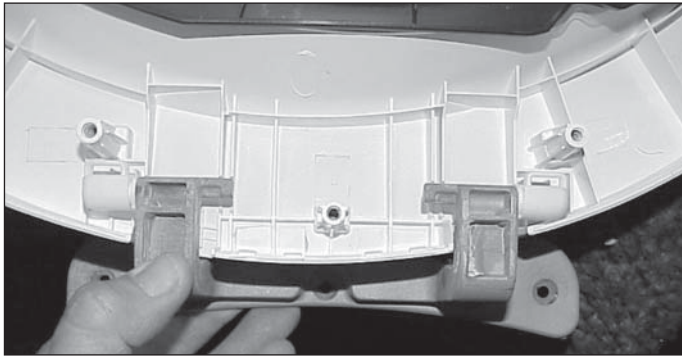

Figure 4-5.

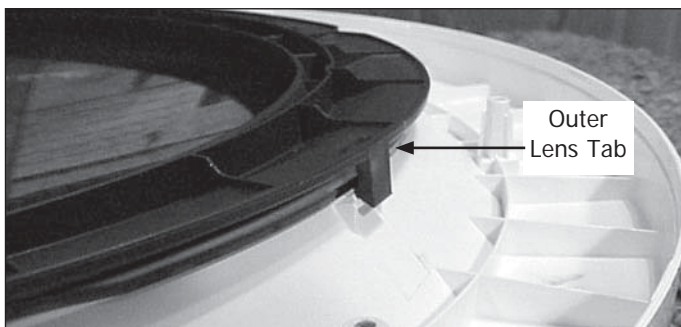

Figure 4-6.

Light Switch Removal

1. Disconnect the washer from electrical supply, remove the top panel and open the loading door.
2. Disconnect the two wires from the light switch. (See Figure 4-8)
3. Squeeze the tabs on the sides of the switch and push the switch out the front of the washer. (See Figure 4-9)

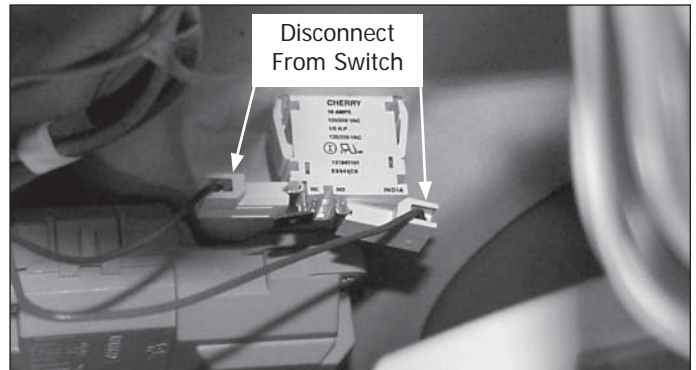

Figure 4-8.

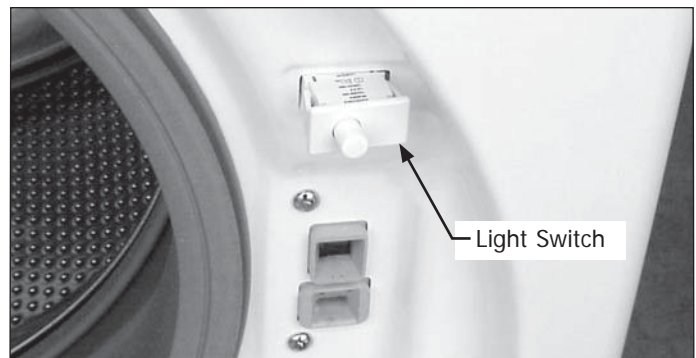

Figure 4-9.

Top Panel Removal

1. Disconnect the washer from the electrical supply.
2. Extract the (2) screws from the rear of the top, slide the top back and lift it off. (See Figure 4-7)

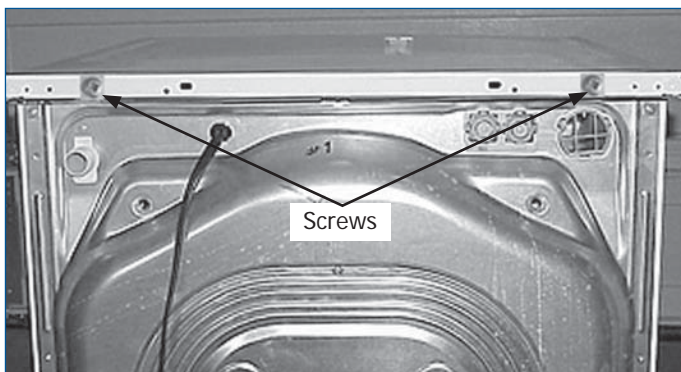

Figure 4-7.

Section 4 Component Teardown

Detergent Drawer Removal

1. Pull the drawer out until it hits the stop.
2. Push down on the release tab and pull the drawer out. (See Figure 4-10 & 4-11)



Figure 4-10.

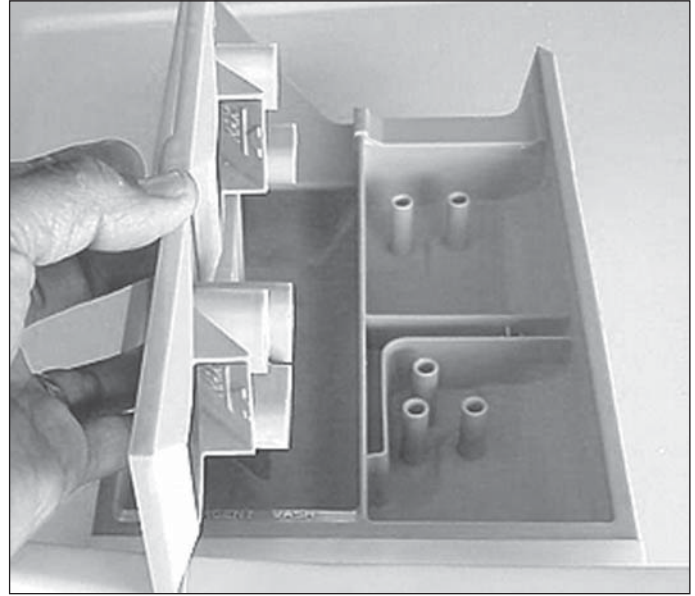

Figure 4-12.



Figure 4-11.

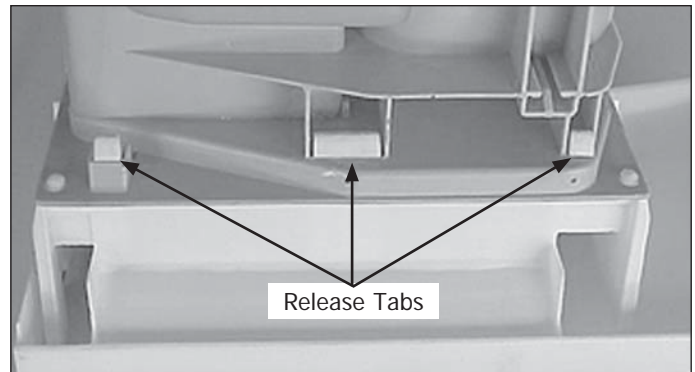

Figure 4-13.

Detergent Drawer Disassembly

1. Remove the drawer from the washer.
2. The detergent, liquid bleach and fabric softener inserts lifts off. When reinstalling, be sure to seat them properly. (See Figure 4-12)
3. To remove the drawer front, release the three tabs and pull the drawer front away from the body. (See Figure 4-13)
4. To remove the conveyor, release the conveyor from the tabs and lift it off. (See Figure 4-14)

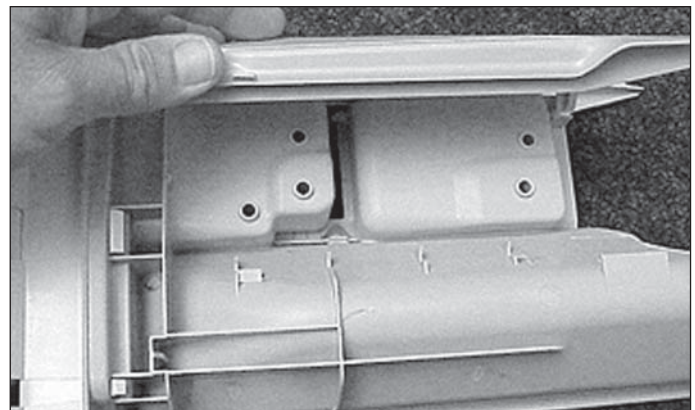

Figure 4-14.

Section 4 Component Teardown

Releasing The Bellows (Door Boot) From Front Panel

The front of the bellows is installed over the lip of the door opening in the front panel and held in place by a spring loaded wire loop.

1. Open the loading door.
2. Using needle nose pliers, start where the spring and wire are connected at the bottom of the bellows and pull the wire out of the groove of the bellows. (See Figure 4-15)
3. Pull the bellows off of the lip of the front panel. (See Figure 4-16)



Figure 4-15.



Figure 4-16.

Door Safety Switch Removal

1. Disconnect the washer from the electrical supply.
2. Release the bellows from the front panel.
3. Remove the (2) screws securing the switch assembly to the front panel. (See Figure 4-17)
4. Pull the switch assembly into the door opening and unplug the electrical connectors. (See Figure 4-18)

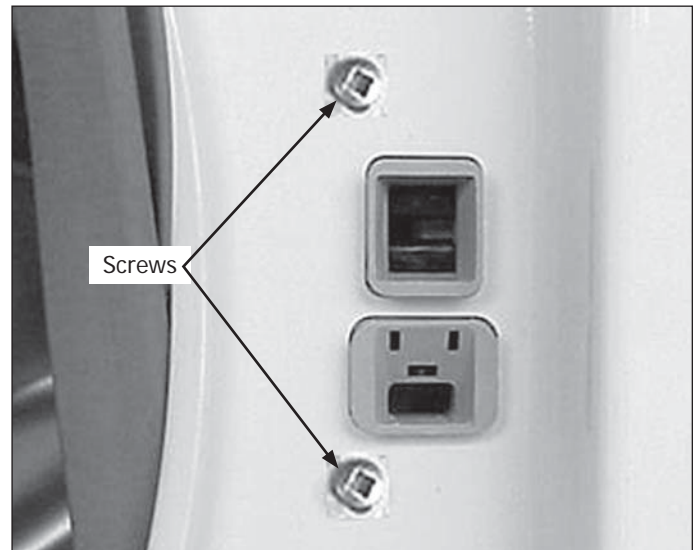

Figure 4-17.

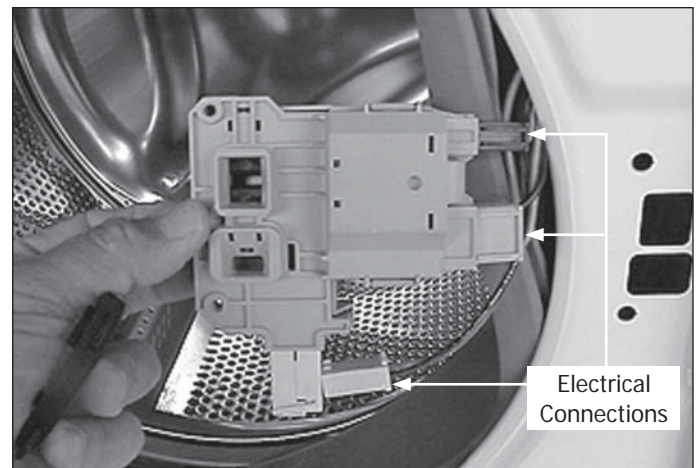

Figure 4-18.

Section 4 Component Teardown

Console Removal

1. Disconnect the washer from the electrical supply, remove the top panel and detergent drawer.
2. Remove the (2) screws, one on each end, holding the console to the top of the side panels. (See Figure 4-19)
3. Remove the (3) screws behind the detergent drawer panel. (See Figure 4-20)
4. Lift the (3) tabs to release the top of console from the mounting plate. (See Figure 4-21)
5. Roll the console forward, while lifting up to release the bottom tabs from the front panel. (See Figure 4-22)
6. Unplug the wiring harness from the control panel and lift the panel off. (See Figure 4-23)

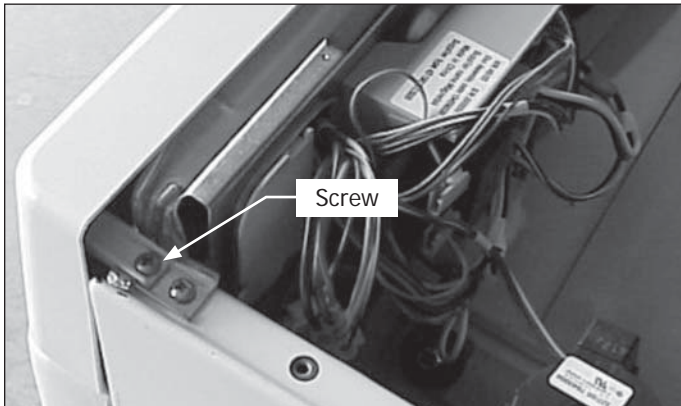

Figure 4-19.

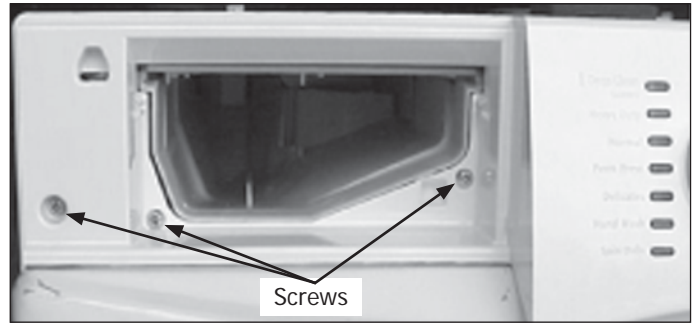

Figure 4-20.

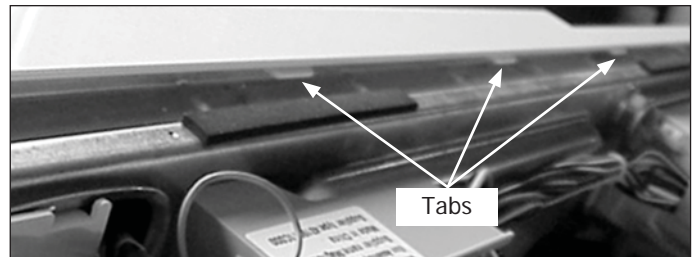

Figure 4-21.

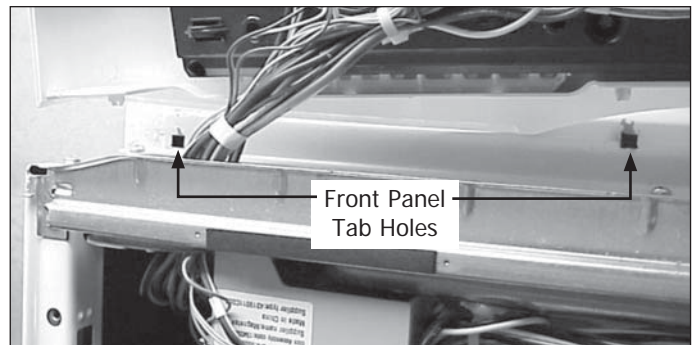

Figure 4-22. Affinity Series

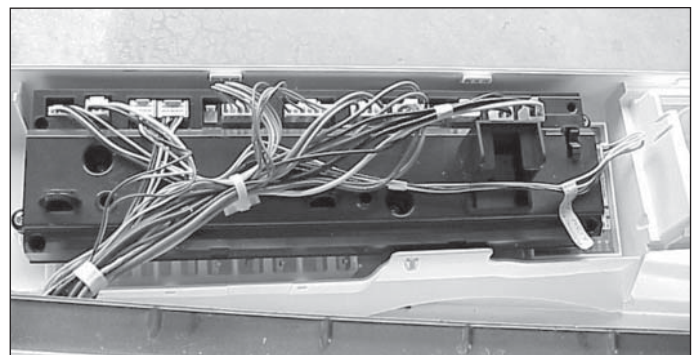

Figure 4-23.

Electronic Control Board Removal

1. Disconnect the washer from the electrical supply and remove the console.
2. Lay the console on a soft flat surface, remove the (5) screws holding the control to the console. (See Figure 4-24)
3. Lift the control out of the console.

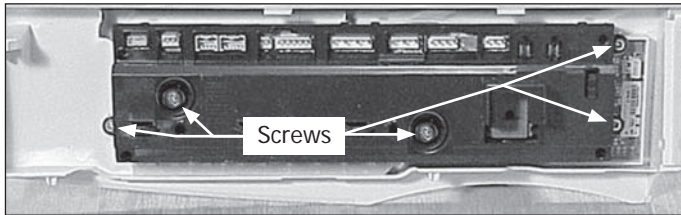

Figure 4-24.

NOTE

When handling and or replacing a control board it is important the a technician have a wrist ground strap on and connected to the cabinet or another grounding position to prevent static electricity from damaging the board.

Delay Start Button Removal

1. Disconnect the washer from the electrical supply and remove the electronic control.
2. With the electronic control removed the delay start button will lift out. (See Figure 4-25)

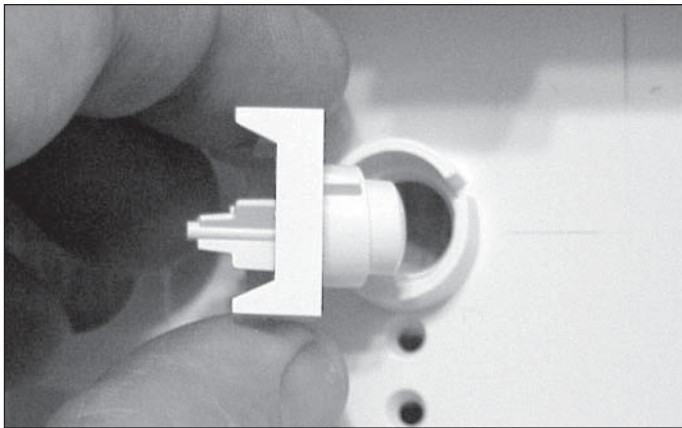

Figure 4-25.

Removing the interface board

1. Disconnect the washer from the electrical supply and remove the electronic control.
2. With the electronic control removed the interface board will lift out. (See Figure 4-26)

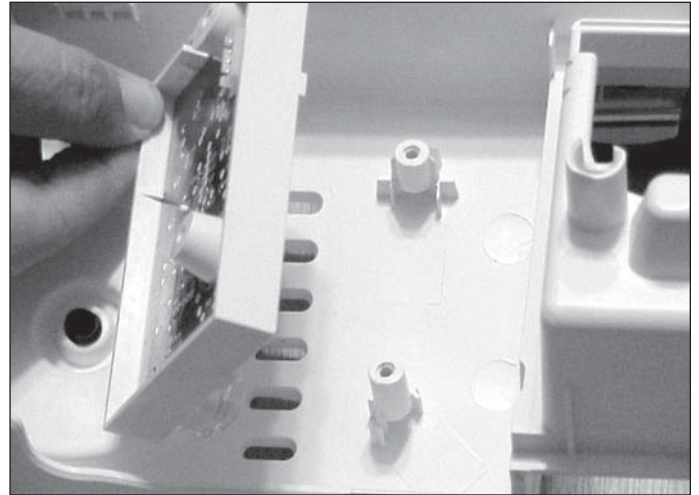

Figure 4-26.

Removing the selector knob

1. Disconnect the washer from the electrical supply and remove the electronic control.
2. Using a pair of pliers squeeze the knob shaft and pull the knob out the front of the control panel. (See Figure 4-27)



Figure 4-27.

Section 4 Component Teardown

Light Socket Removal

1. Disconnect the washer from the electrical supply and remove the top panel.
2. Disconnect the (2) wires from output side of the transformer.
3. Release the bellows from the front panel.
4. Push the light socket holder out of the rear of the bellows. (See Figure 4-28)

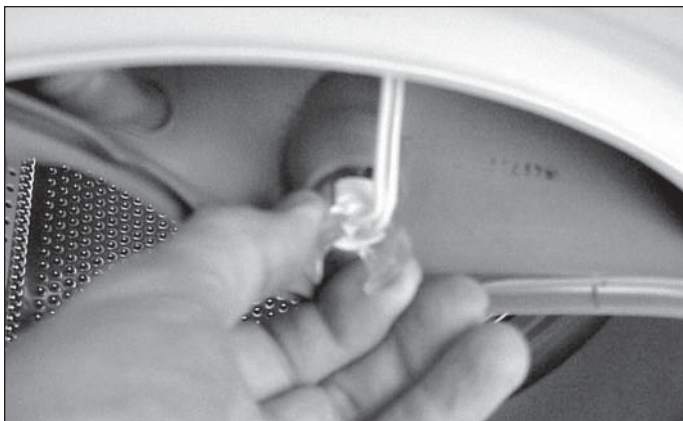

Figure 4-28.

Front Panel Removal

1. Disconnect the washer from the electrical supply and release the console.
2. Release the bellows from the front panel and remove the (2) screws holding the door safety switch assembly to the front panel. (See Figure 4-29)
3. On select models, disconnect the wires from the light switch.
4. Raise the front of the washer and remove the (4) screws securing the front panel to the washer base. (See Figure 4-30)
5. Remove the (4) screws securing top of the panel.
6. Lift up and out on the front panel to disengage it from the (4) nylon pins, two in the front of each side panel, and lift the front panel off. (See Figure 4-31)

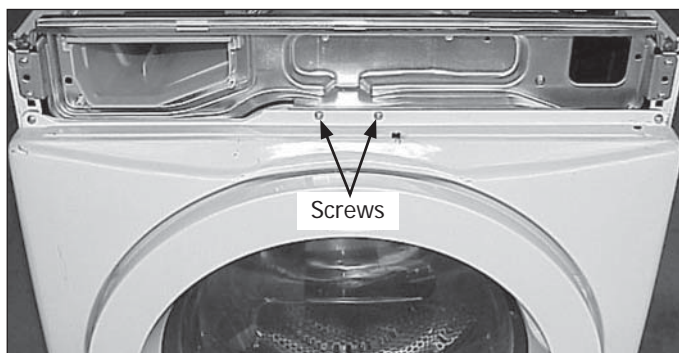

Figure 4-29.

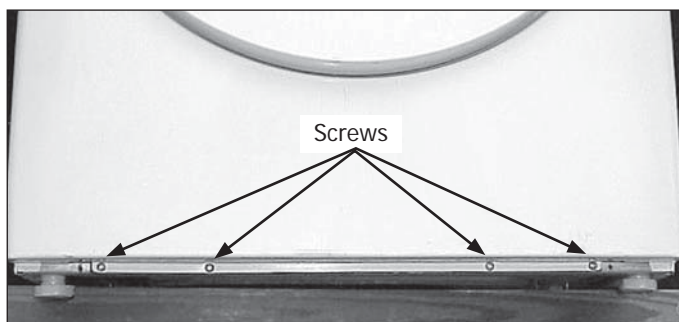

Figure 4-30.

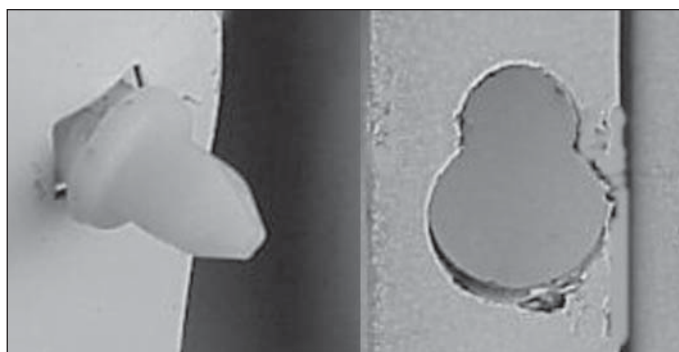

Figure 4-31.

Section 4 Component Teardown

Removing the heater control board

1. Disconnect the washer from the electrical supply and remove the top panel.
2. Unplug the wire harness from the heater control board.
3. Remove the screw holding the heater control board to its mounting bracket. (See Figure 4-32)
4. Release the (2) tabs at the bottom of the board and lift the board out. (See Figure 4-33)

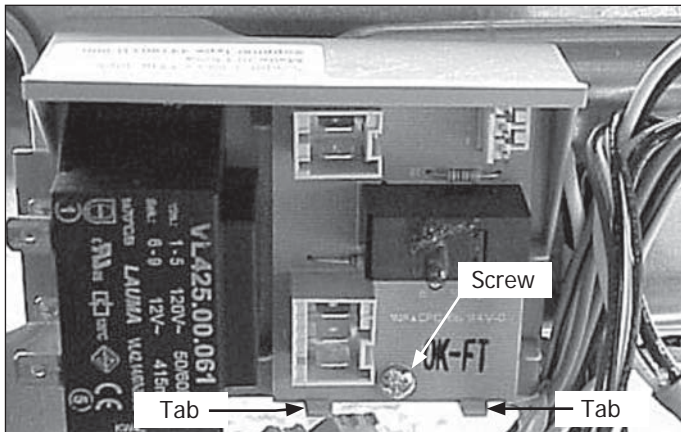

Figure 4-32.

Removing the transformer and heater control board mounting bracket

1. Disconnect the washer from the electrical supply, remove the top panel and release the console.
2. Remove the light transformer and the heater control board.
3. Using needle nose pliers, release the mounting bracket from the control mounting brace. (See Figure 4-34)

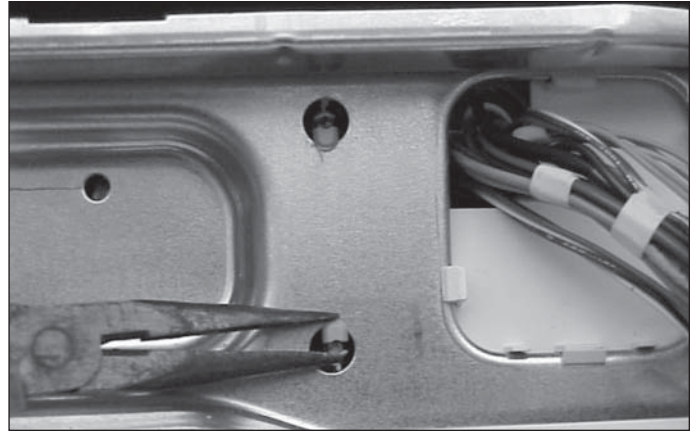

Figure 4-34.

Removing the light transformer

1. Disconnect the washer from the electrical supply and remove the top panel.
2. Unplug the wires from the transformer.
3. Remove the (2) screws holding the transformer to its mounting bracket and lift the transformer out. (See Figure 4-33)

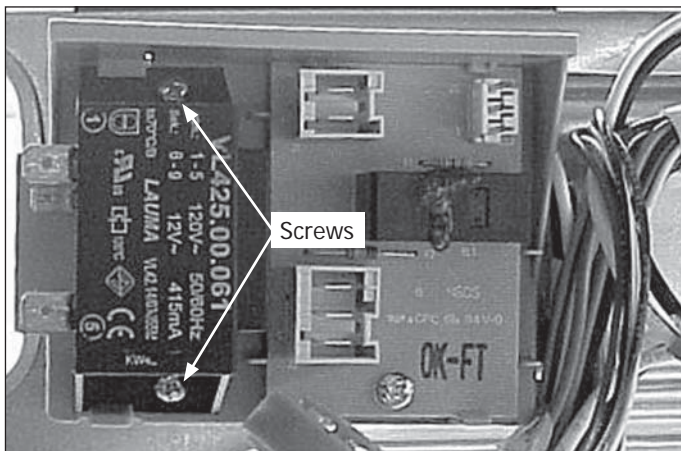

Figure 4-33.

Section 4 Component Teardown

Console Mounting Bracket Removal

1. Disconnect the washer from the electrical supply remove the console and front panel.
2. Release wiring harness from the back of brace and remove transformer and heater control board mounting bracket. Remove the (6) screws, one at the top and two in the front on each side, holding the brace to the side panels. (See Figure 4-35)
3. Release the (2) tabs on the dispenser drawer housing, one on each side of the housing and pull the bracket forward. (See Figure 4-36)

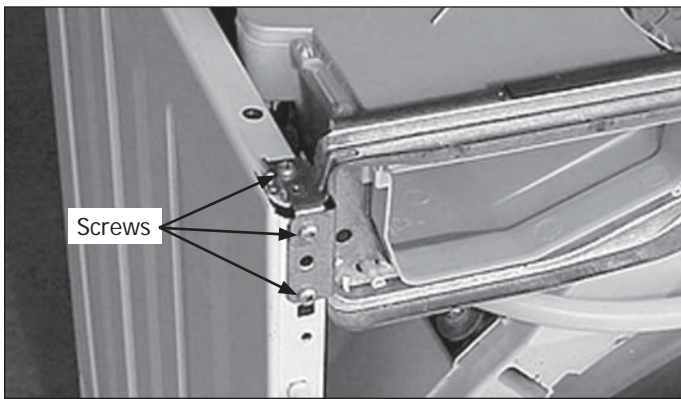

Figure 4-35.



Figure 4-36.

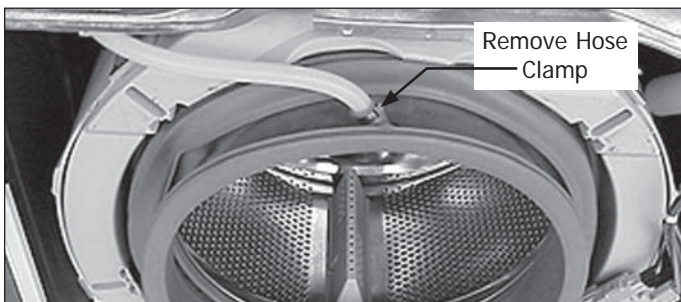

Figure 4-37.

Bellows Removal

1. Disconnect the washer from the electrical supply remove the console and front panel.
2. Release the hose clamp and remove the advanced rinsing technology (A.R.T.) hose from the top of the bellows. (See Figure 4-37)
3. On select models, remove light socket.
4. A groove in the rear of the bellows is placed over the lip of the outer tub and held in place by a spring loop. (See Figure 4-38 & 4-39)
5. Remove the bellows by placing your hand under the bellows at the top of the opening and lift up while pulling out. (See Figure 4-40)

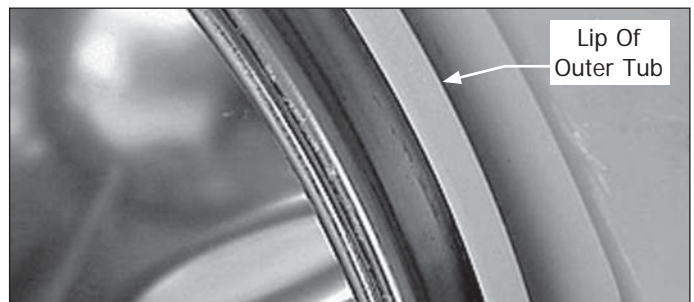

Figure 4-38.

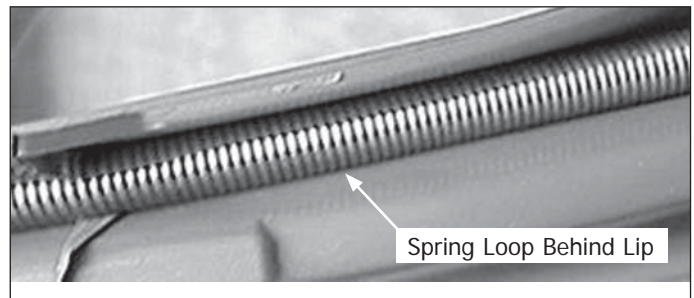

Figure 4-39.

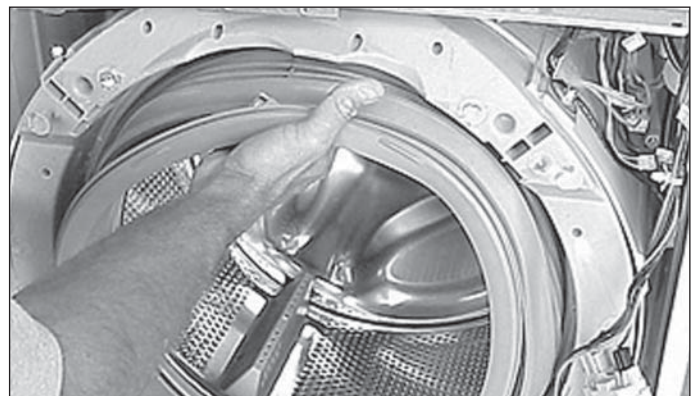

Figure 4-40.

Reinstalling Or Replacing The Bellows

1. Using liquid dishwasher soap to lubricate the groove on the bellows will make it easier to slip the groove on the bellows onto the lip of the tub.
2. There is a tab and an arrow on the top of the tub lip and a slot in the groove and an arrow at the top of the bellows. (See Figure 4-41 & 4-42)
3. Place the slot over the tab and while holding the bellows in place with one hand, place other hand inside bellows and force the groove of the bellows over lip of tub with your thumb. (See Figure 4-43)
4. Work your way about one third way around the tub, then pull in on the inside flap of the bellows to seat the bellows into the lip of the tub. (See Figure 4-44)
5. Using your thumb, start on the other side of the top tab and force the bellows on in the other direction. Again about one third of the way around stop and seat the bellows onto the tub lip. Force the remaining bellows on with your thumb and seat it.
6. To install the spring, fold the front of the bellows back into the tub.
7. Place the spring in the groove at the top of the bellows and wedge a round object, about 3/4 " in diameter, between the weight ring and the bellows to hold the spring in the groove. (See Figure 4-45)
8. Pull the spring with one hand while working it into the groove with the other.
9. Remove the wedge, unfold the bellows, and insert the advance rinsing technology hose and light socket on select models. (See Figure 4-46)

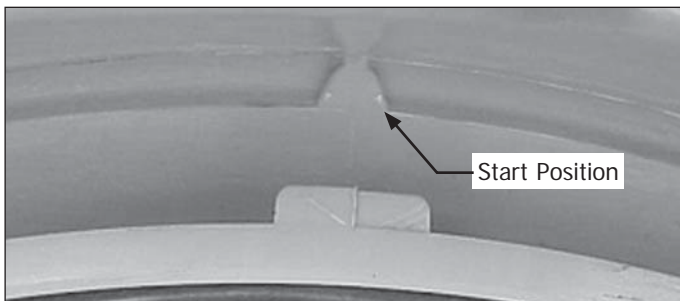

Figure 4-41.

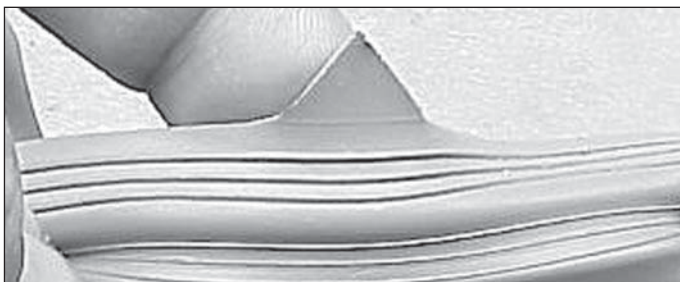

Figure 4-42.

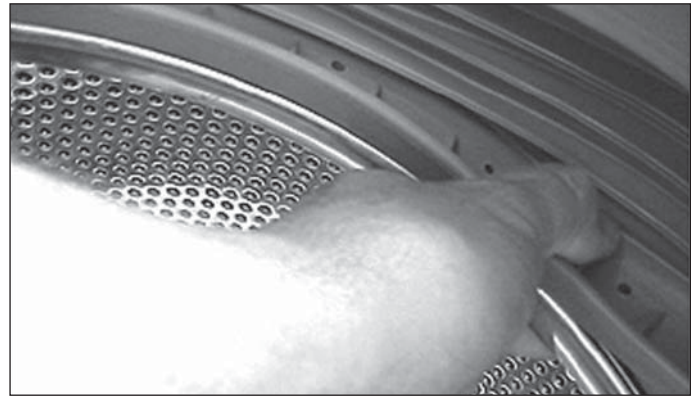

Figure 4-43.

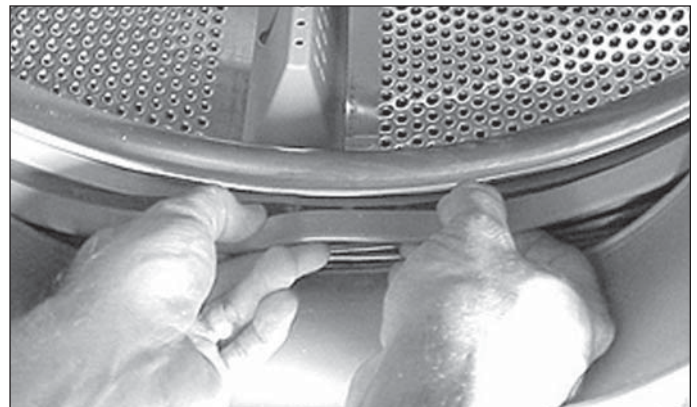

Figure 4-44.

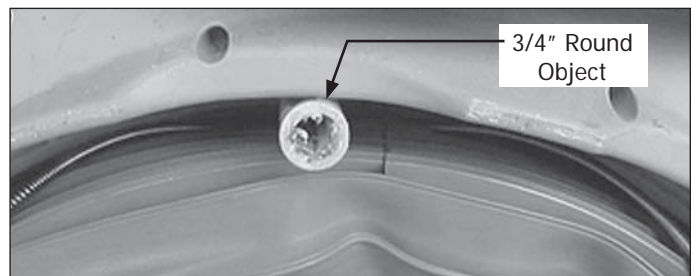

Figure 4-45.

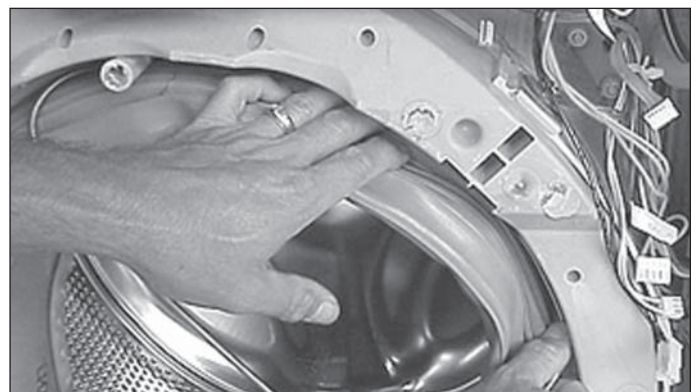

Figure 4-46.

Section 4 Component Teardown

Weight Ring Removal

The weight ring is secured to the front of the outer wash tub assembly with five carriage bolts. The bellows does not have to be completely removed to access and remove the weight ring.

To remove the weight ring:

1. Disconnect the washer from electrical supply.
2. Remove the top panel.
3. Remove control console.
4. Remove the front panel.
5. Disconnect advance rinsing technology hose from bellows.
6. Remove light assembly from bellows.
7. Using a 7/16" socket, remove the (5) bolts holding the weight ring to the outer tub and slide the weight ring off the outer tub front. (See Figure 4-47)

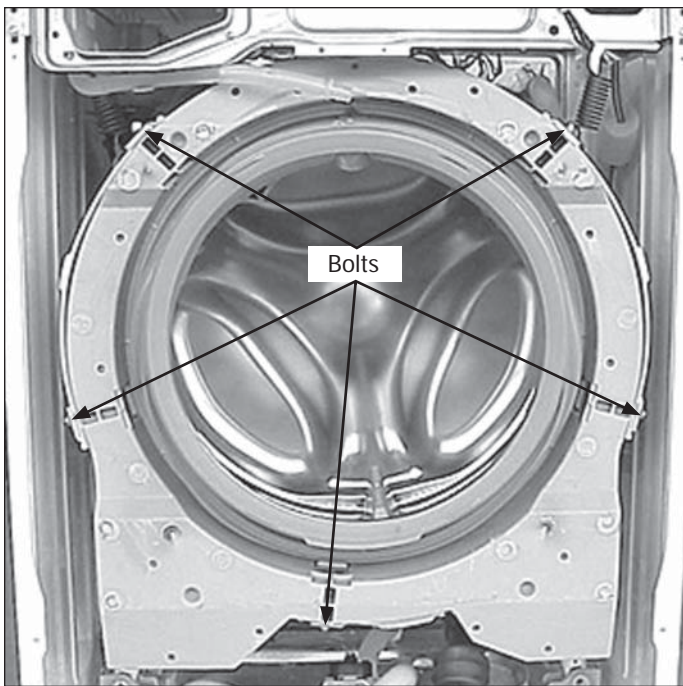

Figure 4-47.

External Drain Hose Removal

1. Release the clamp and pull the hose off the coupler. (See Figure 4-48)

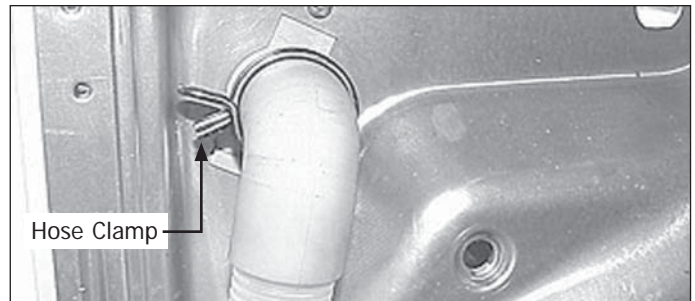

Figure 4-48.

Water Inlet And Overflow/Vent Tube Grommet Removal

The water inlet/ overflow vent tube grommet supports the hot and cold water inlet fittings and the overflow tube. The overflow tube must be removed prior to removing the grommet.

To remove the water inlet/ overflow vent tube grommet:

1. Disconnect the washer from the hot and cold water hoses.
2. Using a small flat bladed screwdriver, release the eight locking tabs around the water inlet tubes while pushing on the grommet rim from inside the washer. (See Figure 4-49)
3. Using a small flat bladed screwdriver, release the three locking tabs around the overflow/vent tube while pushing on the grommet rim from inside the washer. (See Figure 4-49)

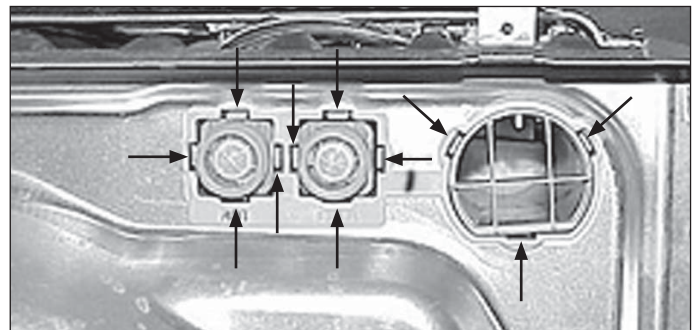

Figure 4-49.

Section 4 Component Teardown

Overflow/Vent Tube Removal

The water inlet/ overflow vent tube grommet supports the hot and cold water inlet fittings and the overflow tube. The overflow tube must be removed prior to removing the grommet.

To remove the water inlet/overflow vent tube grommet:

1. Disconnect the washer from the electrical supply remove the top panel and overflow/vent grommet.
2. Turn the tube counter clockwise about a 1/16 of a turn to unlock the tube. Then pull the tube back to disengage it from the detergent dispenser housing. (See Figure 4-50)
3. Push the front of the tube down and forward toward the water inlet valve assembly until the tube clears the rear panel. (See Figure 4-51)
4. Drop the rear of the tube down, slide the tube back and lift the tube out.

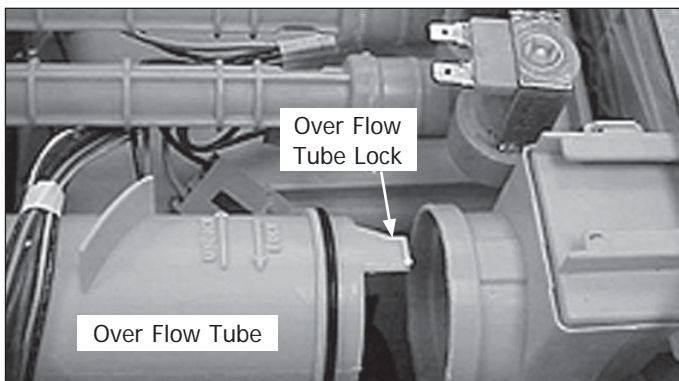

Figure 4-50.

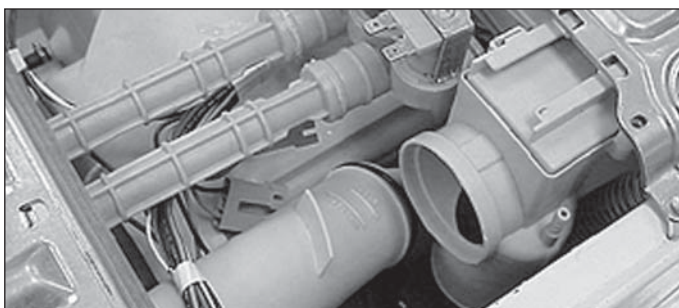

Figure 4-51.

Water Inlet Valve Removal

NOTE

The water valves and water valve harness connectors are color coded; red, green and blue. When reconnecting, match the color on the harness connector to the color of the valve.

The water inlet/ overflow vent tube grommet supports the hot and cold water inlet fittings and the overflow tube. The overflow tube must be removed prior to removing the grommet.

To remove the water inlet/overflow vent tube grommet:

1. Disconnect the washer from the electrical supply and the hot and cold water hoses.
2. Remove the top panel, water valve and overflow/vent grommet and the overflow/vent tube.
3. Unplug the wiring harness from the valves and the temperature sensor. (See Figure 4-52 & 4-53)

NOTE

The water valve harness has locking plugs.

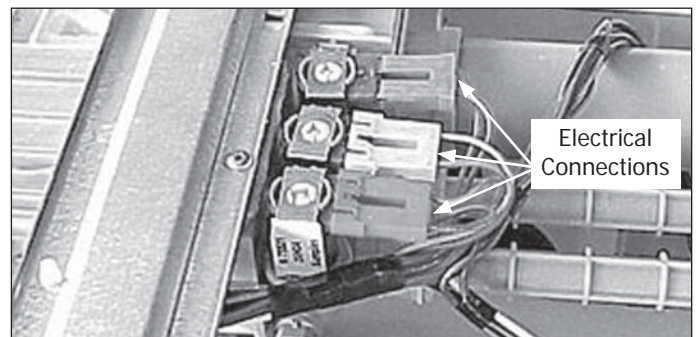

Figure 4-52.

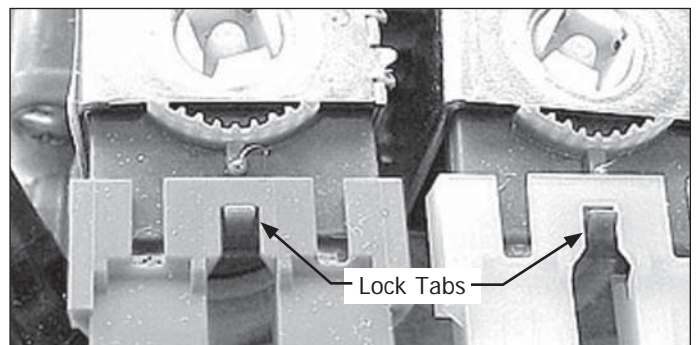

Figure 4-53.

Section 4 Component Teardown

Water Inlet Valve Removal

4. Remove the (2) screws, one on each side, holding the water inlet valve assembly to the detergent dispenser housing. (See Figure 4-54)
5. Pull back on the valve assembly to disengage it from the detergent dispenser housing and lift out. (See Figure 4-55)

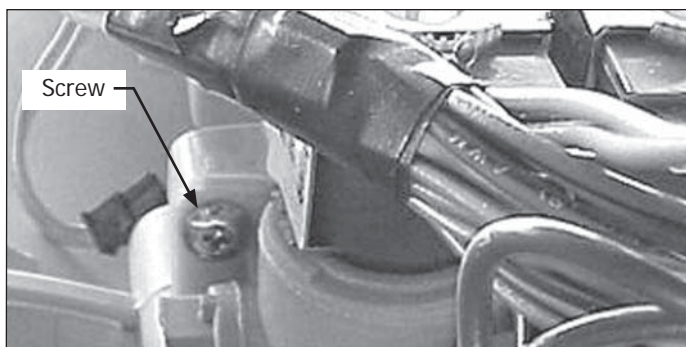

Figure 4-54.

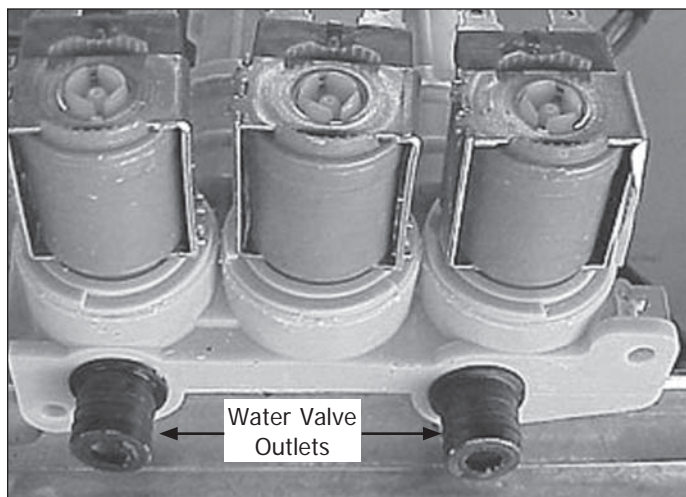

Figure 4-55.

Water Inlet Screen Removal

Water inlet screens are located in the ends of the water inlet tubs to filter the incoming water. These screen can be removed for cleaning.

To remove the water inlet screens:

1. Disconnect the incoming water hoses.
2. Each screen has a reinforced bar across the face. Using a pliers, grab one of the legs of the bar and pull the screen out. (See Figure 4-56)

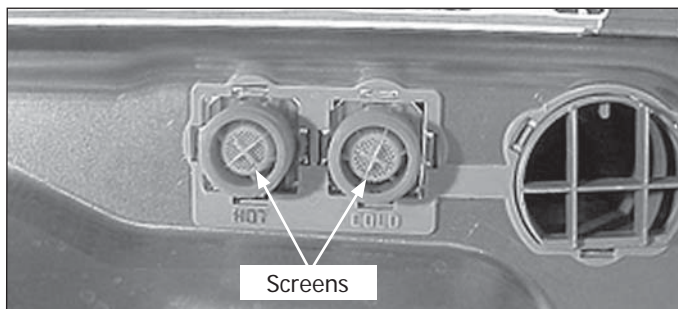

Figure 4-56.

Top Rear Brace Removal

To remove the top rear brace:

1. Remove the top panel.
2. Using a #2 square bit screwdriver, extract the three screws from the rear of the top rear brace. (See Figure 4-57)
3. Extract the two screws from the top of the rear brace and remove from unit. (See Figure 4-58)

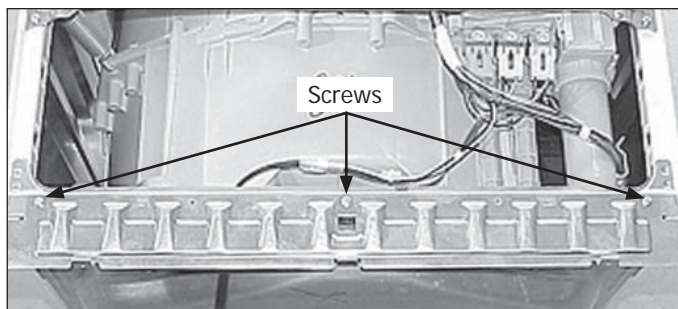

Figure 4-57.

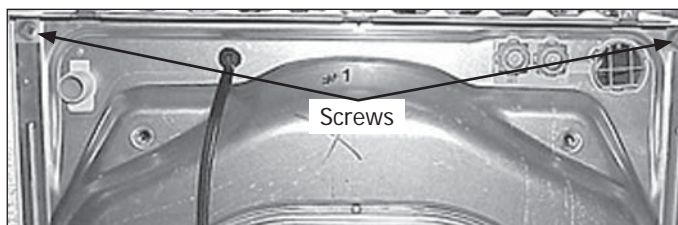

Figure 4-58.

Section 4 Component Teardown

Suspension Springs Removal

1. Disconnect the washer from the electrical supply and remove the top panel.
2. It is necessary to hook the top of the spring, raise it about 1" to release the top hook from the center brace flange, then allow it to drop about 6" to relieve the spring pressure and then unhook the other end of the spring from the tub. (See Figure 4-59)

To do this a strong rod at least 8" long with a hook on one end and a handle on the other is needed, such as the one shown here made from a paint roller. (See Figure 4-60)

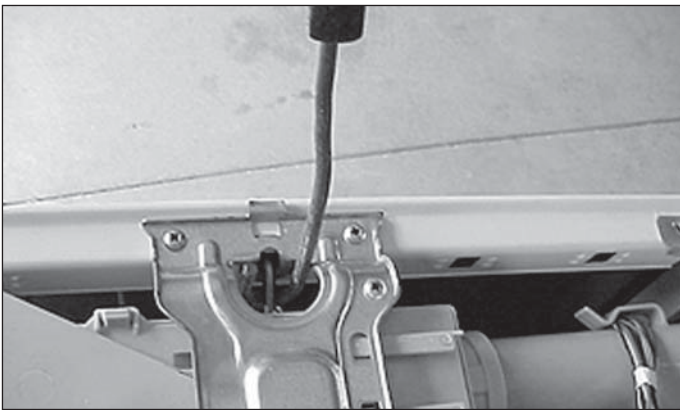

Figure 4-59.



Figure 4-60.

Top Center Brace Removal

1. Disconnect the washer from the electrical supply and remove the top panel.
2. Release the tub springs and slide the water valve assembly back.
3. Remove the (4) screws, two on each end, and the (2) screws holding the detergent dispenser housing to the brace. (See Figure 4-61)
4. Raise the brace to disengage the tabs on the brace from the side panels and slide the brace backward to release the tabs on the brace from the slot in the detergent dispenser housing. (See Figure 4-62)

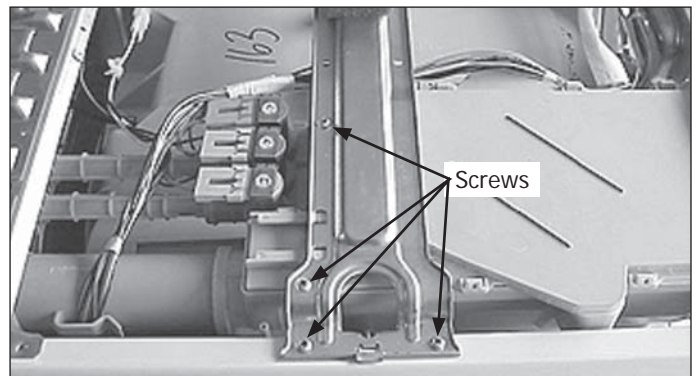

Figure 4-61.

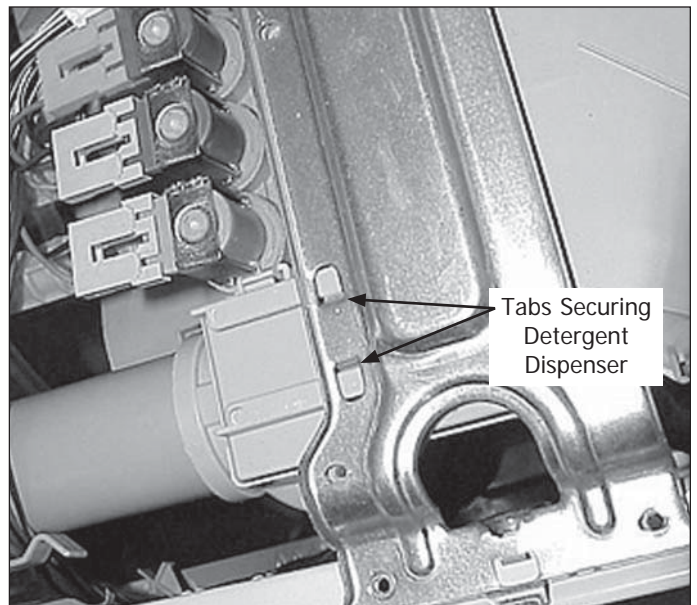

Figure 4-62.

Section 4 Component Teardown

Detergent Cavity Assembly Removal

1. Disconnect the washer from the electrical supply, remove the drawer and the top panel.
2. Disconnect the water valve assembly and the overflow/vent tube and slide them back.
3. Release wiring harness from the side of housing.
4. Disconnect the detergent dispenser outlet hose. (See Figure 4-63)
5. Remove the (2) screws holding the housing to the center brace. (See Figure 4-64)
6. Remove the (2) screws holding the housing to the console panel. (See Figure 4-65)
7. Release the (2) tabs, one on each side, locking the housing to the console mounting panel. (See Figure 4-66)
8. Slide the housing back until the tabs of the center cross bar release and the housing drops down.
9. Disconnect the advanced rinsing technology hose. (See Figure 4-67)
10. Push down on the tub and swing the front of the housing toward the center of the washer. Work the housing out from under the center brace and lift the housing out. (See Figure 4-68)

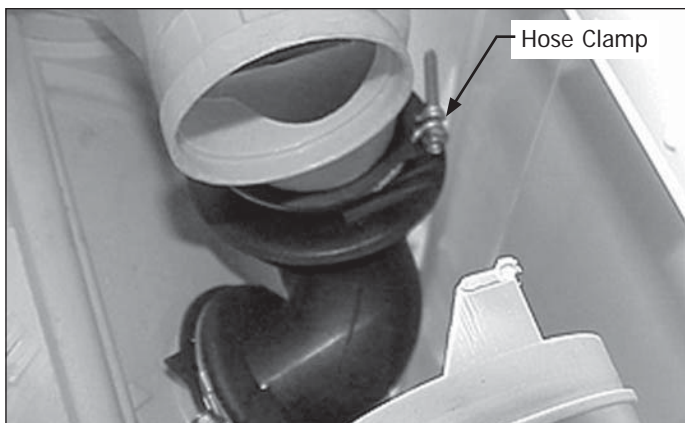

Figure 4-63.

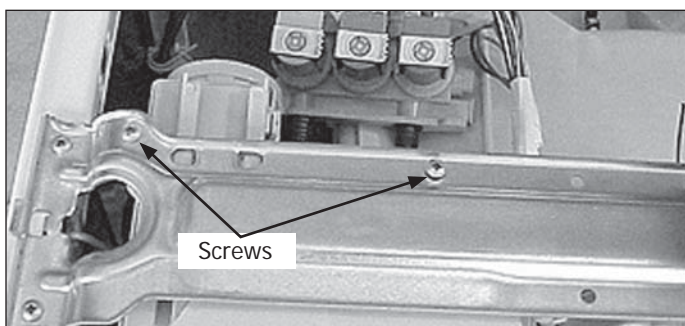

Figure 4-64.

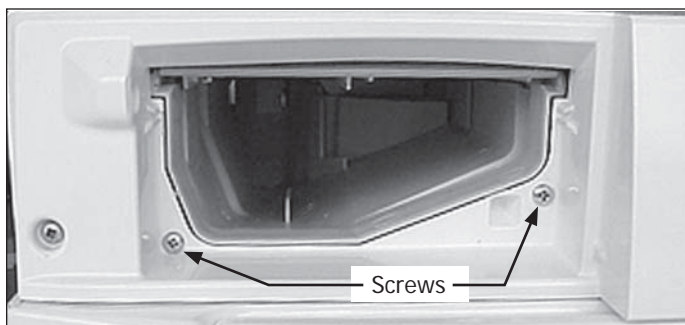

Figure 4-65.

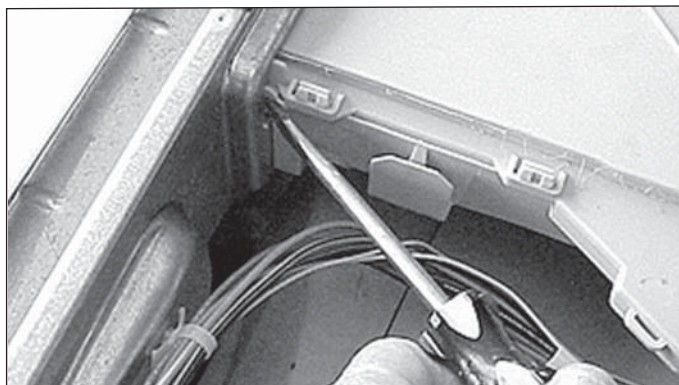

Figure 4-66.

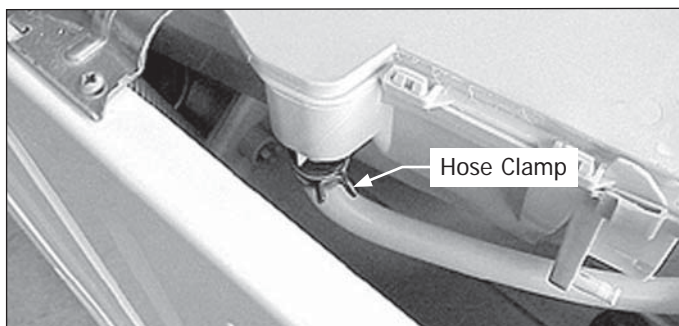

Figure 4-67.

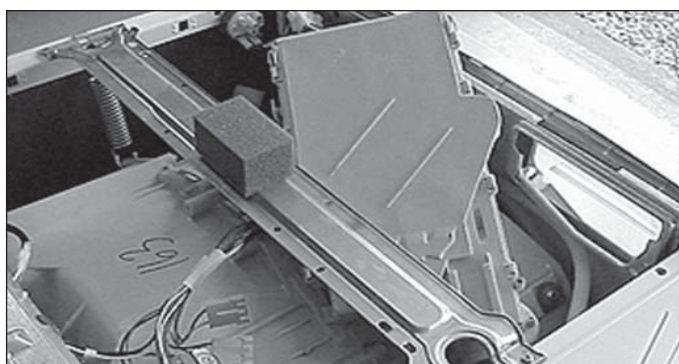

Figure 4-68.

Section 4 Component Teardown

Detergent Dispenser Outlet Hose Removal

1. Disconnect the washer from the electrical supply and remove the top panel.
2. Release the overflow/vent tube and slide it back.
3. Loosen the (2) clamps, one on each end, and slide the hose off. (See Figure 4-69)

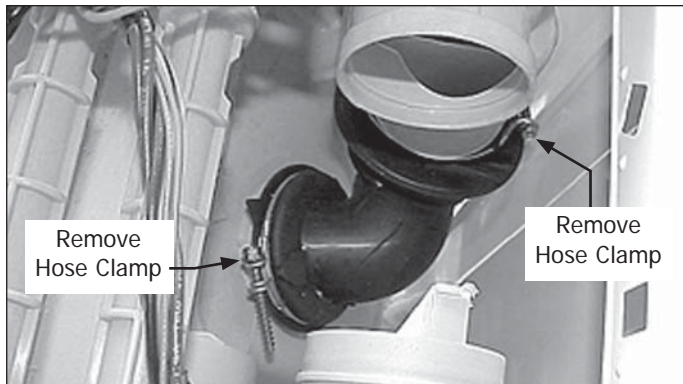

Figure 4-69.

Siphon Break Hose Removal

1. Disconnect the washer from the electrical supply and remove the top panel.
2. Release the (2) clamps, one on each end, and slide the hose off. (See Figure 4-70)

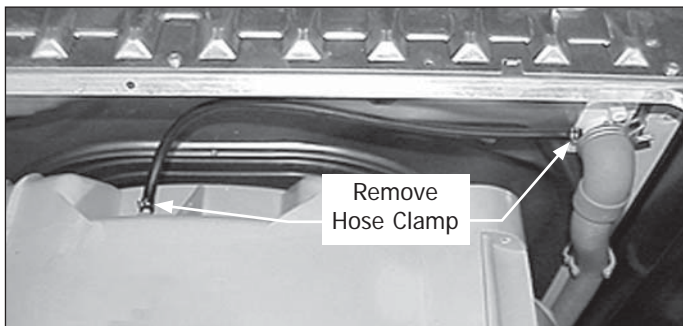

Figure 4-70.

Drain Pump Removal

1. Disconnect the washer from the electrical supply and remove the front panel.
2. Disconnect the inlet sump from the pump. (See Figure 4-71)
3. Disconnect the outlet hose from the pump. (See Figure 4-72)
4. Remove the (2) screws, one on each side, holding the pump housing to the washer base. (See Figure 4-73)
5. Unplug the wires from the pump motor and lift the pump assembly out.

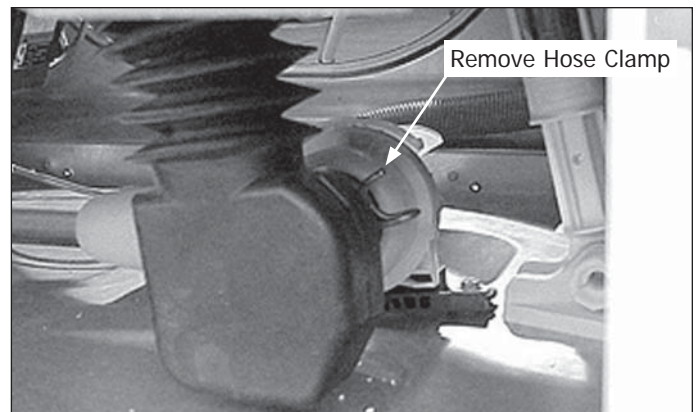

Figure 4-71.

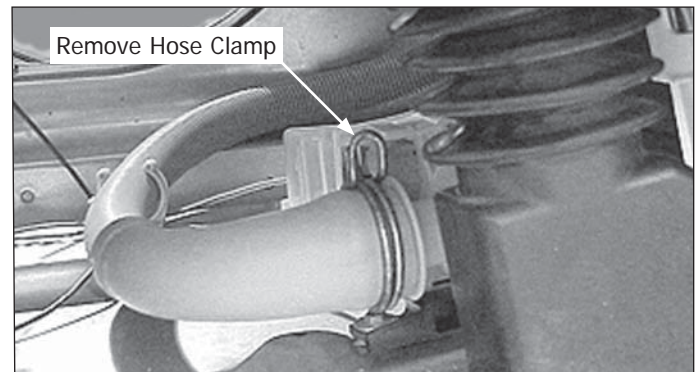

Figure 4-72.

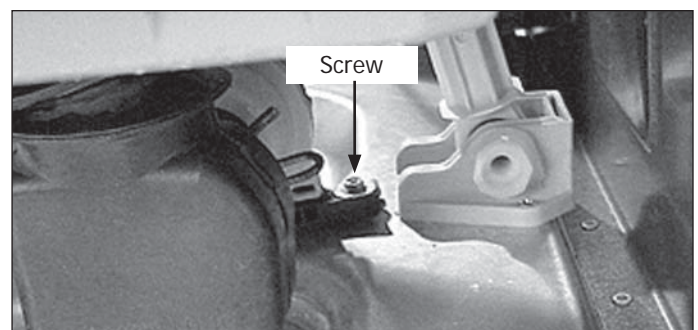

Figure 4-73.

Section 4 Component Teardown

Drain Pump Disassembly

1. The drain pump check valve is located in the outlet of the pump. (See Figure 4-74)
2. Remove the shield by releasing the tab and pulling back on the shield. (See Figure 4-74)
3. Release the tab on each side of the motor and pull back to remove the armature. (See Figure 4-75)
4. Remove (4) screws to release the housing from the pump. (See Figure 4-76)

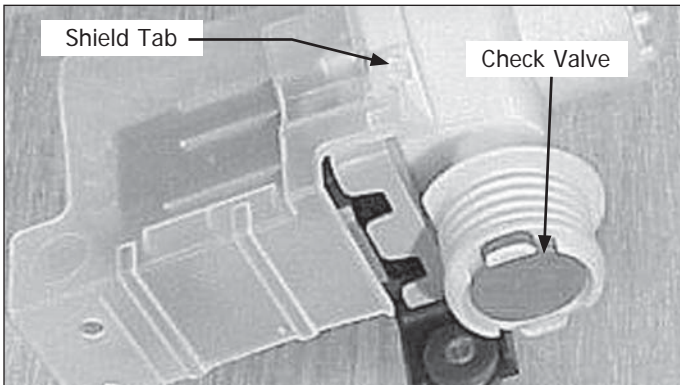

Figure 4-74.

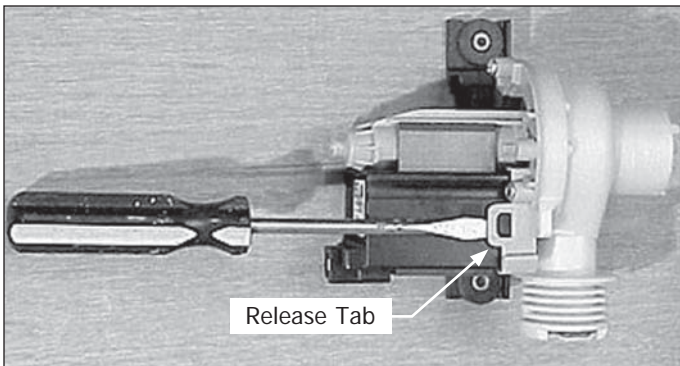

Figure 4-75.

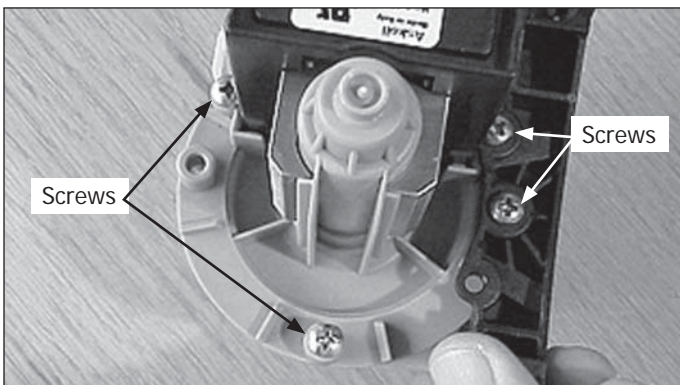

Figure 4-76.

Electric Water Level Sensor Removal

1. Disconnect the washer from the electrical supply and remove the top panel.
2. Unplug the wire harness from the sensor. (See Figure 4-77)
3. Turn the sensor one quarter turn to release it from the side panel and pull out on the sensor. (See Figure 4-78)
4. Disconnect the pressure hose from the sensor. (See Figure 4-78)

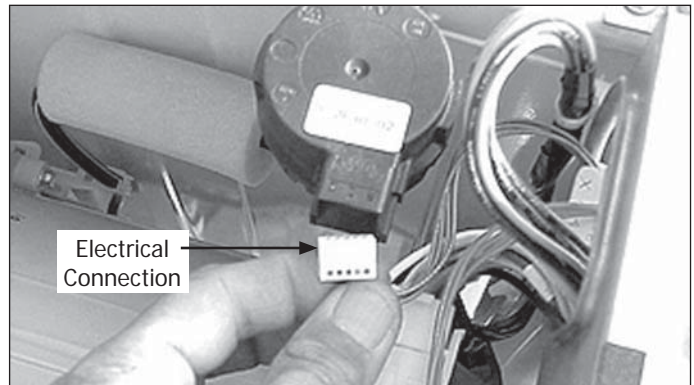

Figure 4-77.

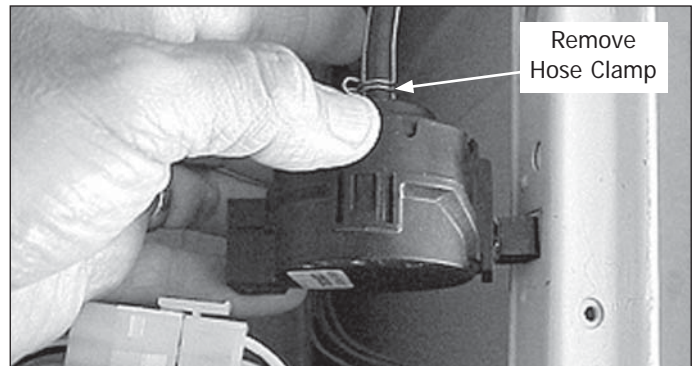

Figure 4-78.

Section 4 Component Teardown

Drain Sump

1. Disconnect the washer from the electrical supply and remove the front panel.
2. Loosen the clamp at the tub. (See Figure 4-79)
3. Release the clamp at the pump. (See Figure 4-80)
4. Slide the hose off the tub and pump to remove the sump.

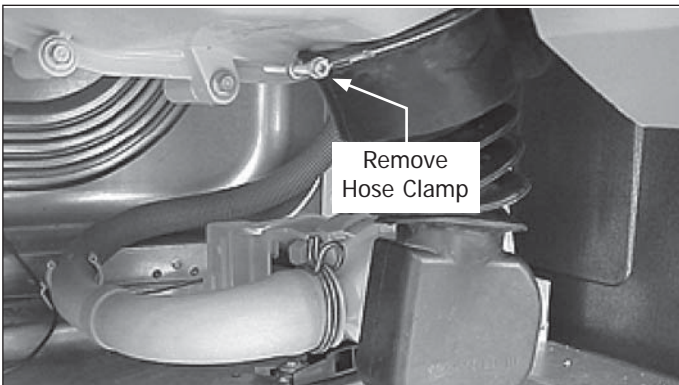

Figure 4-79.

Drain Pump Outlet Hose Removal

1. Disconnect the washer from the electrical supply and remove the top and front panel.
2. Release the clamp and slide the hose off of the drain pump. (See Figure 4-81)
3. Release the clamp and slide the hose off the drain hose coupler. (See Figure 4-82)
4. Release the hose from its guides and pull the hose out.

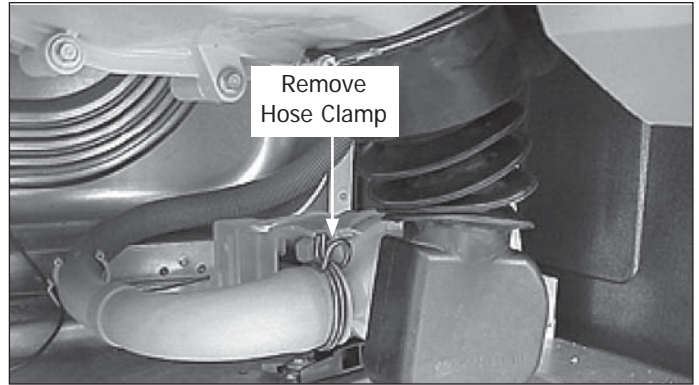

Figure 4-81.

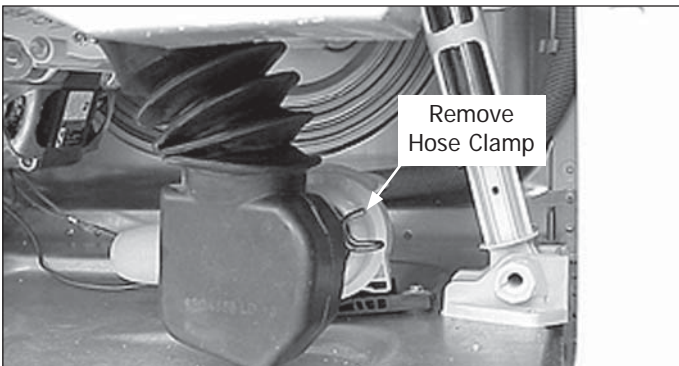

Figure 4-80.

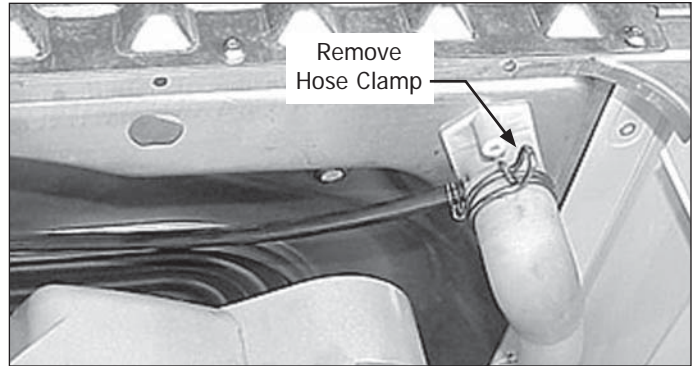

Figure 4-82.

Section 4 Component Teardown

Drain Hose Coupler Removal

1. Disconnect the washer from the electrical supply and remove the top panel.
2. Disconnect the (2) drain hoses and siphon break hose.
3. Remove screw holding coupler to the rear panel and pull coupler out the back. (See Figure 4-83)

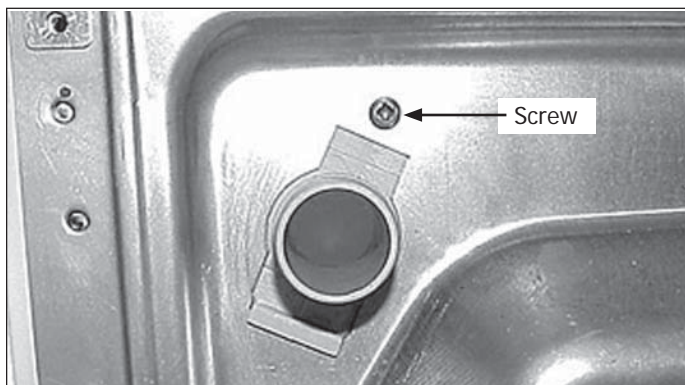

Figure 4-83.

Rear Access Panel Removal

1. Disconnect the washer from the electrical supply.
2. Remove the (6) screws holding the rear access panel to the washer's rear panel and lift the access panel off. (See Figure 4-84)

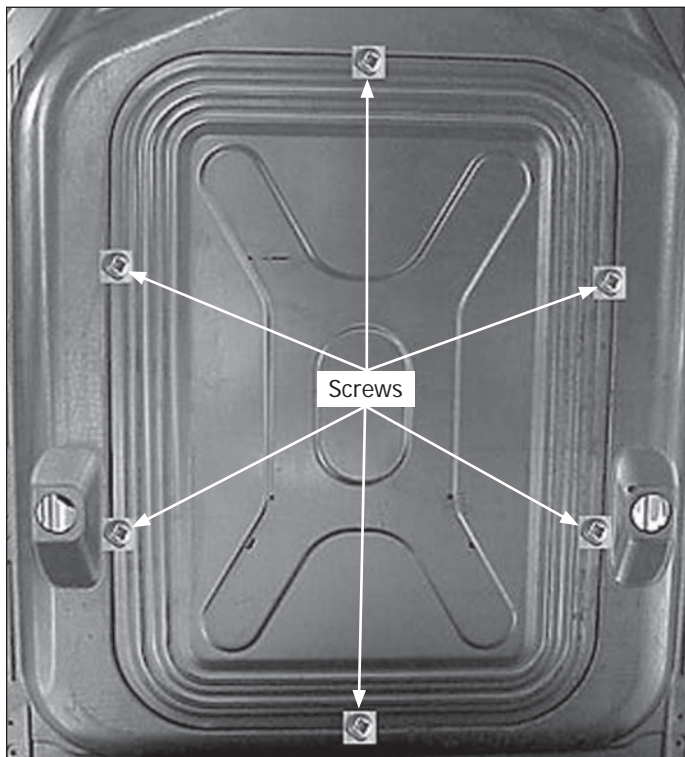

Figure 4-84.

Drive Belt Removal

The drive belt (6 rib flat Poly-V) is used to transmit power from the motor pulley to the tub. The belt is constructed of a material that stretches, which makes belt tension adjustments unnecessary.

Removing or replace the drive belt:

1. Disconnect the washer from the electrical supply and remove the rear access panel.
2. Remove the belt by turning tub drive pulley and rolling belt off pulley. The belt is elastic and is designed to "give" enough to remove and install in this manner. (See Figure 4-85)

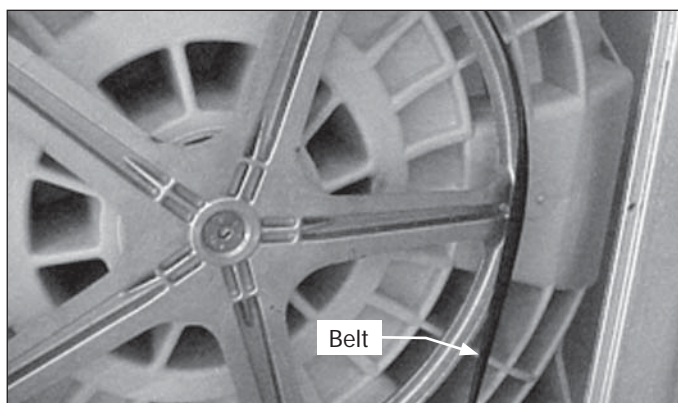

Figure 4-85.

Large Pulley Removal

To remove the large pulley:

1. Disconnect the washer from the electrical supply.
2. Remove the rear access panel and drive belt.
3. Using a #6 mm allen wrench remove bolt in the center of pulley by holding the pulley and turning the bolt counter clockwise. (See Figure 4-86)
4. Work the pulley back and forth to remove it from the shaft.

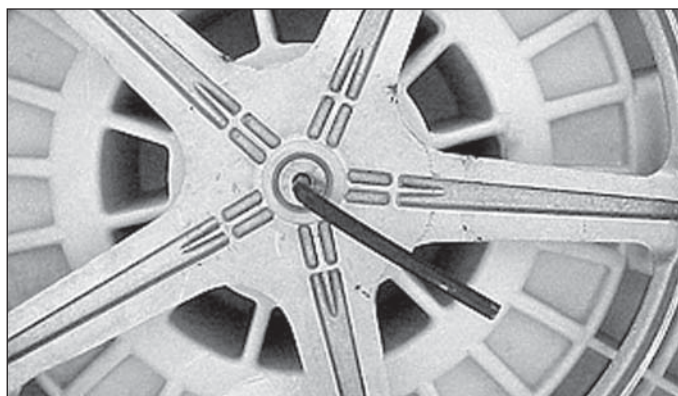

Figure 4-86.

Section 4 Component Teardown

Drive Motor Removal

1. Disconnect the washer from the electrical supply and remove the rear access panel and the belt.
2. Disconnect the electrical plug and the ground wire from the motor. (See Figure 4-87)
3. Using a 5/16" socket remove the (4) bolts, (2) in the front and (2) in the rear, that hold the motor to the outer tub. (See Figure 4-88 & 4-89)
4. Slide motor forward while supporting to remove.
5. Reverse procedure to reinstall, making sure the belt tracks in the center of the large pulley. Adjust by moving belt on motor pulley if required.

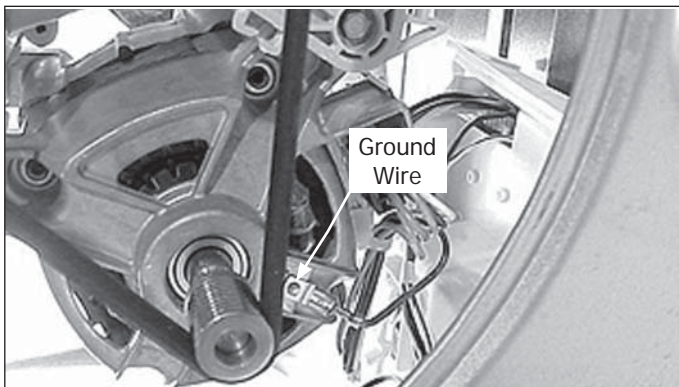

Figure 4-87.

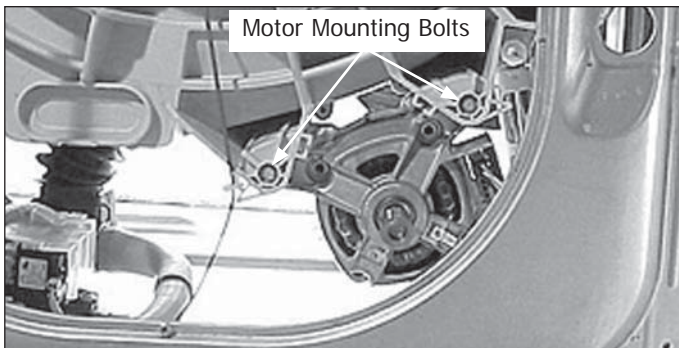

Figure 4-88.

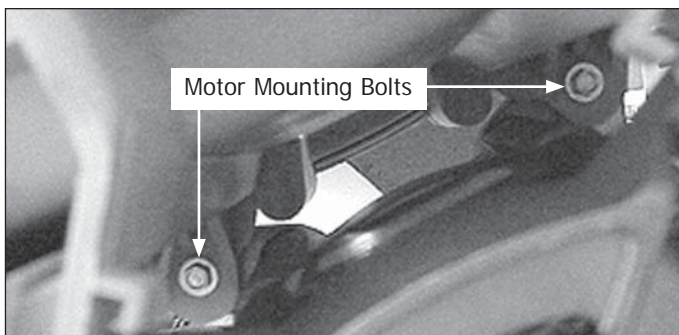

Figure 4-89.

Speed Control Board Assembly Removal

1. Disconnect the washer from the electrical supply and remove the front panel and rear access panel.
2. Disconnect the terminal plug from the lower front. (See Figure 4-90)
3. Disconnect the wire harness and remove the screw securing the tab on the side of the control board to the base. Lift the side of the housing up, slide the assembly to the rear to disengage the front tab and lift the assembly away from the washer base. (See Figure 4-91)
4. From the front of the washer tip the bottom of the assembly toward the motor and slide the assembly out between the shock absorber and the motor.

(continued next page)

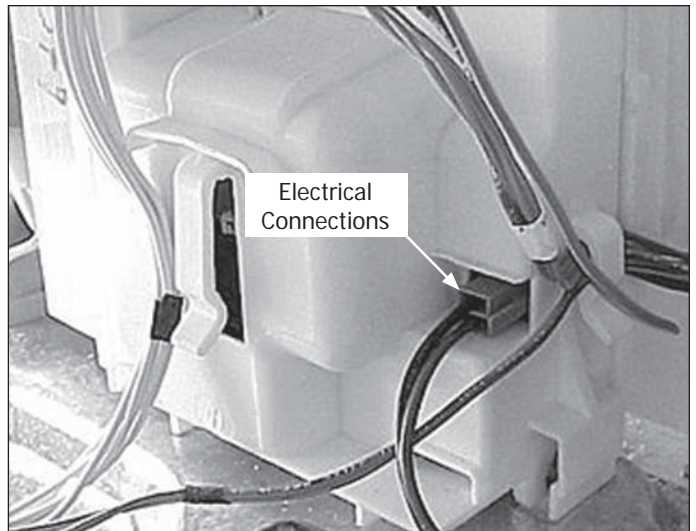

Figure 4-90.

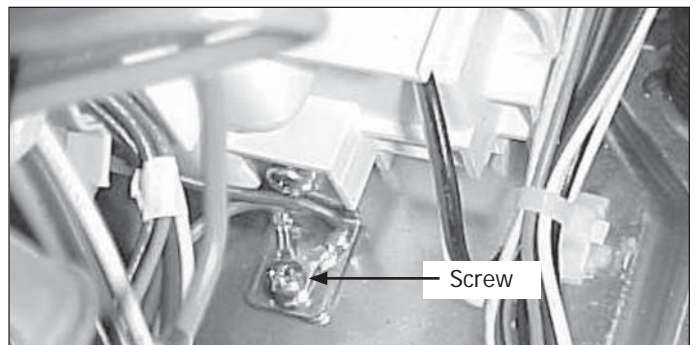

Figure 4-91.

Section 4 Component Teardown

Speed Control Board Assembly Removal (continued)

5. Release the latch on each end of the speed control housing and raise the top flap. (See Figure 4-92)
6. Disconnect the (2) plugs & the ground wire and remove the speed control assembly from the washer. (See Figure 4-93)

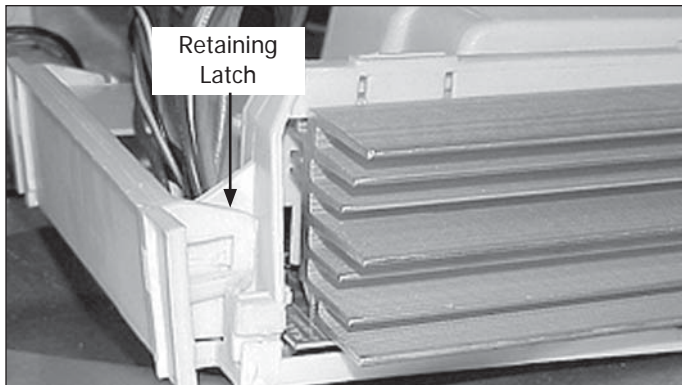

Figure 4-92.

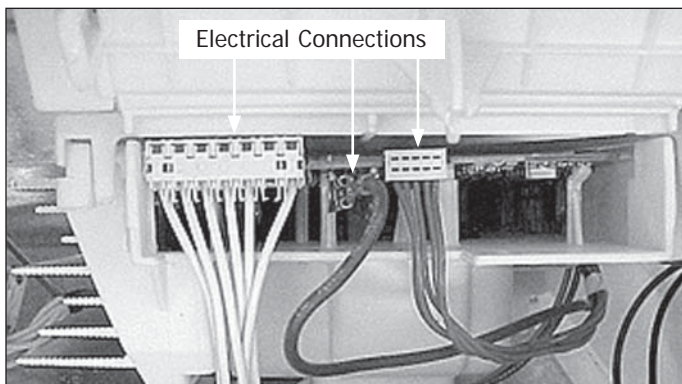

Figure 4-93.

Right Hand Air Shock Absorber Removal

1. Disconnect the washer from electrical supply.
2. Remove the front panel and the rear access panel.
3. Remove air shock securement pins by depressing locking tab while pulling pin to remove. (See Figure 4-94)

NOTE

This procedure is much easier if a deep 1/2", 6 point socket (or 13 millimeter, 6 point) is used to compress the locking tab of the plastic pin. Push the socket onto the tapered end of the pin as far as it will go to compress the locking tab.

4. Use pliers to grasp head of pin and pull to remove. As the pin is removed the socket will drop free.
5. When replacing the air shock, make sure to position it with the bell end facing downward.
6. Lubricate the securement pins with Sil-Glide® before installing.

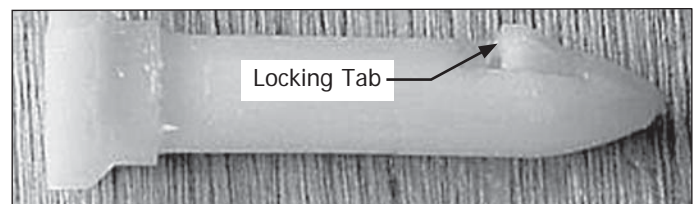

Figure 4-94.



Figure 4-95.

Left Hand Air Shock Absorber Removal

1. Disconnect the washer from electrical supply.
2. Remove the front panel and the rear access panel.
3. Remove the speed control board assembly.
4. Remove air shock securement pins by depressing locking tab while pulling pin to remove.

NOTE

This procedure is much easier if a deep 1/2", 6 point socket (or 13 millimeter, 6 point) is used to compress the locking tab of the plastic pin. Push the socket onto the tapered end of the pin as far as it will go to compress the locking tab.

5. Use pliers to grasp head of pin and pull to remove. As the pin is removed the socket will drop free.
6. When replacing the air shock, make sure to position it with the bell end facing downward.
7. Lubricate the securement pins with Sil-Glide® before installing.

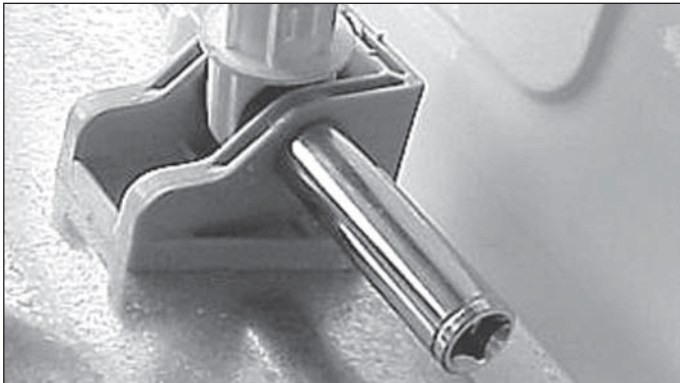

Figure 4-96.

Heating Element Removal

The heating element is held and sealed to the tub by compressing the rubber gasket between the two metal mounting plates of the element. When the nut in the center of the element mounting plate is tightened, the two metal plates are drawn together compressing the rubber gasket.

1. Disconnect the washer from electrical supply and remove the rear access panel.
2. Disconnect the wires from the heating element and the drum water NTC. (See Figure 4-97)
3. Loosen the compression nut and pull the heater assembly out of the drum. (See Figure 4-97)

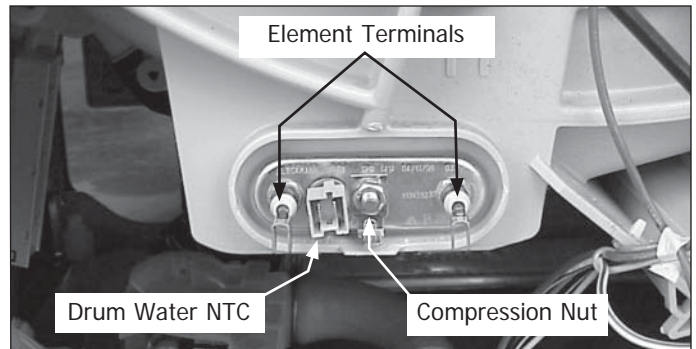

Figure 4-97.

Drum Water NTC Removal

1. Disconnect the washer from electrical supply and remove the rear access panel.
2. Disconnect the wires from the drum water NTC. (See Figure 4-97)
3. Loosen the compression nut and pull the drum water NTC out of the heater assembly.

Section 4 Component Teardown

Air Bell Removal

1. Disconnect the washer from the electrical supply and remove the front panel.
2. Remove the (2) hoses, (1) from each end. (See Figure 4-98)
3. Remove retainer securing air bell in position and remove from unit. (See Figure 4-99)

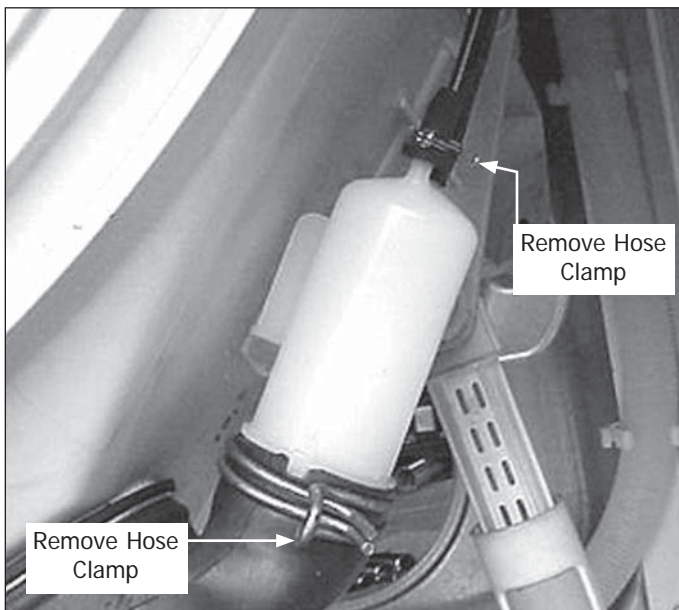

Figure 4-98.

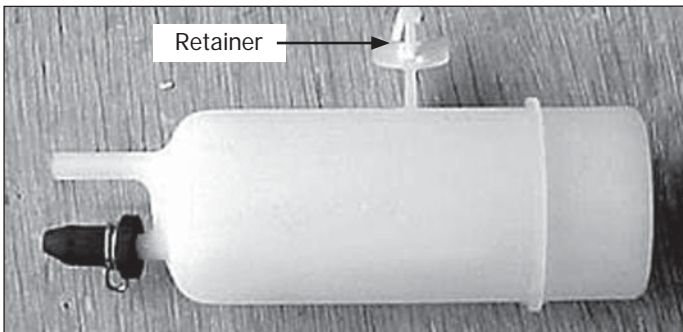

Figure 4-99.

NOTE

Seal air connecting tube to air bell and air bell to sump hose using waterproof glue. DO NOT plug air connecting tube opening.

Tub Assembly Removal

1. Disconnect the washer from the electrical supply and the hot and cold water hoses.
2. Remove the top panel, console, rear access panel and the front panel.
3. Disconnect the advance rinsing technology hose from the bellows, the detergent outlet and siphon break hoses from the outer tub.
4. Remove the drain pump and disconnect the drain sump from the tub.
5. If you are going to replace the front half of the outer tub remove the bellows and the weight ring.
6. Remove the small hose from the air bell.
7. Remove the large pulley, drive motor and speed control board assembly.
8. Disconnect bearing ground wire. (See Figure 4-100)
9. Remove the top pins from shock absorbers and push the shock absorbers against the cabinet. (See Figure 4-101)
10. Place something down to protect the floor, carefully turn the washer on its face and release the springs. (continued next page)

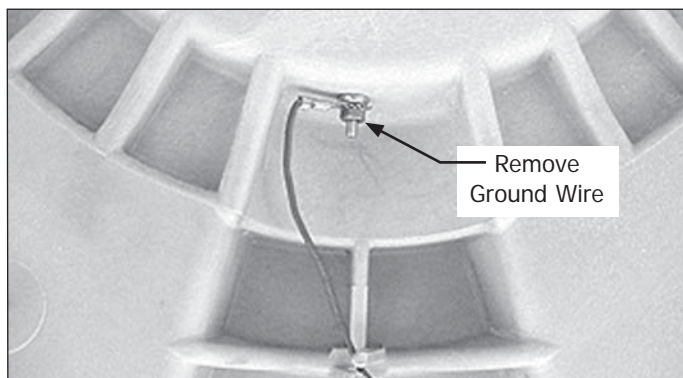

Figure 4-100.



Figure 4-101.

Section 4 Component Teardown

Tub Assembly Removal (continued)

11. Lift the cabinet off the tub. (See Figure 4-102)
12. Turn the tub over and remove the (23) screws holding the two halves of the tub together. (See Figure 4-103)
13. Lift off the front half of the tub. (See Figure 4-104)

CAUTION

Use caution in handling the spin basket. The outer surface is very sharp!

14. Reverse procedure to reassemble using illustration below to show outer tub screw tightening sequence. (See Figure 4-105) (continued next page)

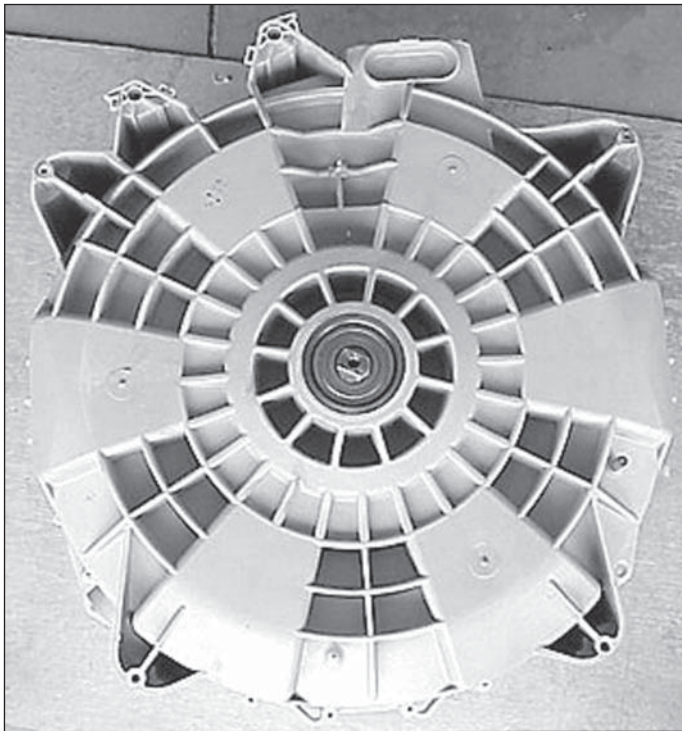

Figure 4-102.

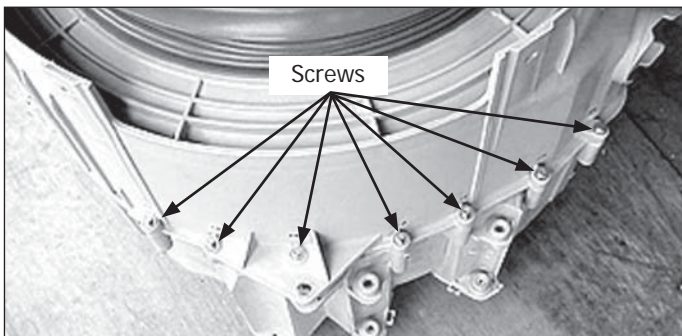

Figure 4-103.

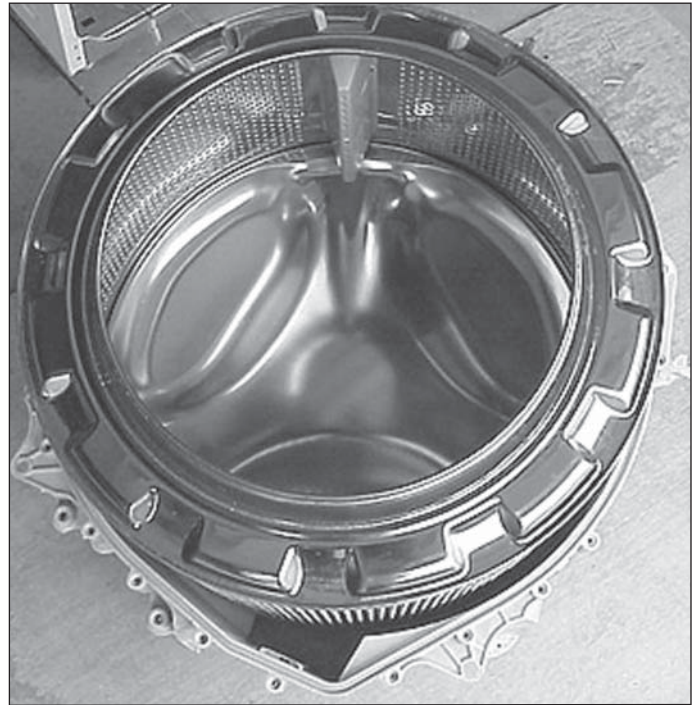

Figure 4-104.

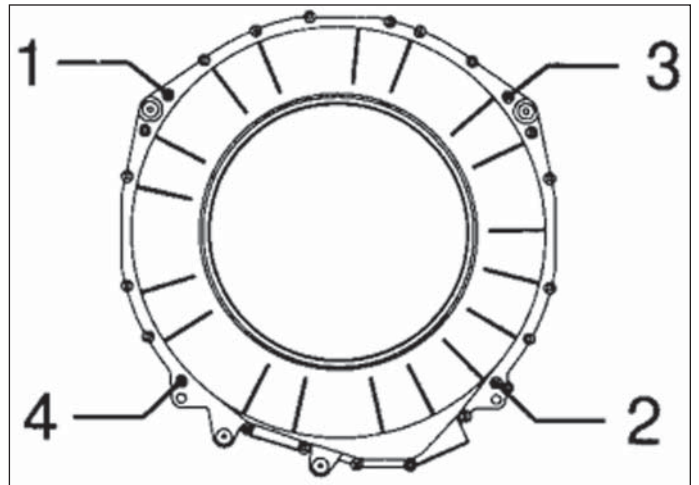

Figure 4-105.

Section 4 Component Teardown

15. The seal between the (2) tub halves is placed in the groove of the rear half and can be lifted out. (See Figure 4-106)
16. To remove the spin basket, set the back half of the outer tub on it's side, reinstall the screw that holds the large pulley on and tap the inner tub out with a rubber hammer. (See Figure 4-107 & 4-108)

CAUTION

The bearings, water seal and seal between the two tubs come as part of the rear half of outer tub. If the water seal or bearings fail, inspect and if necessary dress shaft of the spin basket with a file. With some failures, it may be necessary to replace the spin basket.

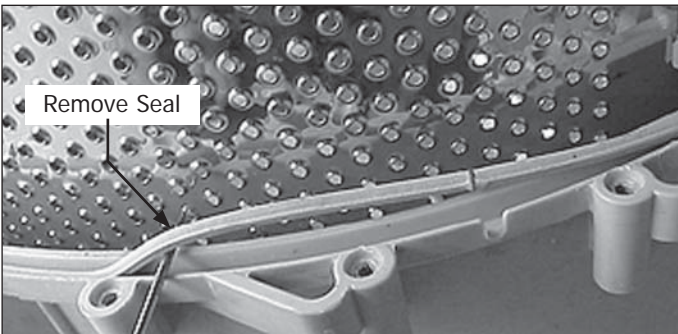

Figure 4-106.



Figure 4-107.

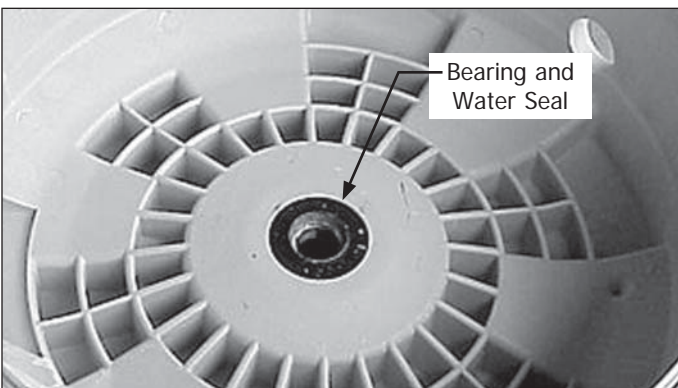

Figure 4-108.

Spin Basket Vanes Removal

There are three plastic vanes mounted to the spin basket to aid in the washing action during the wash cycle. The vanes are held to the spin basket by (6) tabs that are slipped into slots in the spin basket and locked in place by (4) tabs pressed out of the spin basket.

Removing the spin basket vanes:

1. Open the washer's loading door.
2. Insert a small shaft common screwdriver into the hole in top of the vane behind the divided space and push the (4) locking tabs open. (See Figure 4-109)
3. Slide vane towards the door opening to release the (6) tabs and push on side of vane to remove. (See Figure 4-110)
4. When replacing or reinstalling, secure the vane with a stainless steel screw through the slot in the side of the vane. (See Figure 4-109)

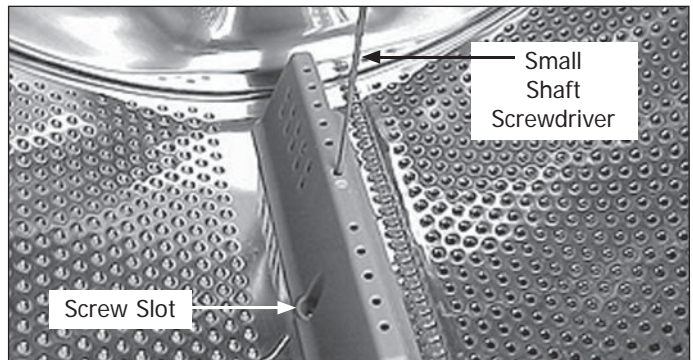

Figure 4-109.

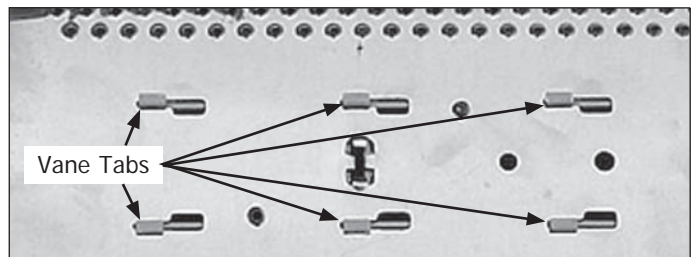

Figure 4-110.

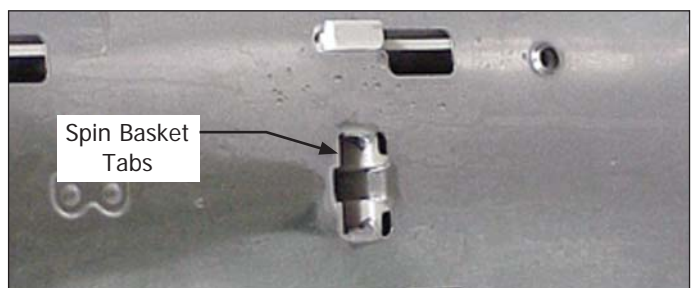

Figure 4-111.

Section 5 Troubleshooting

The following troubleshooting chart involves problems arising from improper washing techniques and are not valid service issues. Many washing problems involve poor soil and stain removal, residues of lint and scum, and fabric damage. For satisfactory washing results, follow these suggestions provided by The Soap and Detergent Association.

For Troubleshooting the electronic control and error codes, See Section Three Electronic Control.

Problem	Cause	Correction
Blue stains	<ol style="list-style-type: none"> 1. Undiluted liquid detergent or fabric softener dispensed directly onto fabric. 	<ol style="list-style-type: none"> 1. If caused by detergent, mix 1 cup (240 ml) white vinegar with 1 quart (.95 L) water in plastic container. Soak item 1 hour. Rinse. 2. If caused by fabric softener, rub stains with bar soap. Wash again. 3. Avoid overfilling detergent and fabric softener compartments of dispenser.
Discoloration, graying	<ol style="list-style-type: none"> 1. Not enough detergent. 2. Wash temperature too low. 3. Incorrect sorting. 	<ol style="list-style-type: none"> 1&2. Rewash with correct amount of detergent and hottest water safe for fabric. Add bleach safe for fabric. 3. Sort items by soil level and color.
Greasy, oily stains	<ol style="list-style-type: none"> 1. Not enough detergent. 2. Undiluted liquid fabric softener poured directly on fabric. 	<ol style="list-style-type: none"> 1. Treat with prewash stain remover or liquid detergent. 2. Increase detergent and water temperature. Rewash. 3. Rub fabric softener stains with bar soap.
Holes, tears, or snags	<ol style="list-style-type: none"> 1. Incorrect use of chlorine bleach. 2. Unfastened zippers, hooks, buckles. 3. Rips, tears and broken threads. 4. Overloading the washer. 5. Degradation of fabric. 	<ol style="list-style-type: none"> 1. Never pour chlorine bleach directly on fabric. 2. Check condition of items before washing. See Washing Procedures in the Use and Care Guide for preparing, loading and adding chlorine bleach.
Lint	<ol style="list-style-type: none"> 1. Incorrect sorting. 2. Tissues left in pocket. 3. Overloading the washer. 4. Not enough detergent. 5. Undissolved detergent has left a residue resembling lint. 6. Static cling is attracting lint. 7. Load washed too long. 	<ol style="list-style-type: none"> 1. Reduce load size. Rewash using correct water temperature, water level, and amount of detergent. 2. Add nonprecipitating water conditioner to wash water to remove detergent residue. 3. Add liquid fabric softener to final rinse. 4. Dry load in dryer. 5. Remove lint with lint brush or roller.
Pilling (Fibers break off, ball up and cling to fabric.)	<ol style="list-style-type: none"> 1. Pilling is normal with synthetic and permanent press fabrics. This is due to abrasion from normal wear. 	<ol style="list-style-type: none"> 1. Use a lint brush or shaver to remove pills. 2. Use fabric softener in the washer to lubricate fibers. 3. When ironing, use spray starch or fabric finish on collars/cuffs. 4. Turn items inside out to reduce abrasion.

Section 5 Troubleshooting

Problem	Cause	Correction
Residue or powder on dark items; stiff, harsh fabrics.	<ol style="list-style-type: none"> 1. Undissolved detergent. 2. Some nonphosphate granular detergents can combine with hard water minerals to form a residue. 3. Overloading the washer. 	<ol style="list-style-type: none"> 1. Increase water temperature using hottest water safe for fabric. 2. Do not overload washer. 3. Use liquid detergent or use nonprecipitating water conditioner with nonphosphate granular detergent.
Wrinkling	<ol style="list-style-type: none"> 1. Overloading the washer. 2. Incorrect wash cycle for wash load. 	<ol style="list-style-type: none"> 1. Reduce load size. 2. Rinse in cold water with liquid fabric softener using the Perm Press or Delicate cycle. 3. Remove items from washer as soon as cycle is completed.
Yellow buildup of body soil on synthetic fabrics	<ol style="list-style-type: none"> 1. Agitation time too short. 2. Wash water temperature too low. 3. Not enough detergent. 	<ol style="list-style-type: none"> 1. Soak in detergent booster or product containing enzymes. 2. Wash in hot water (120°F/49°C) using full permanent press cycle. Increase detergent. Add bleach or treat with color remover.
Yellow or brown rust stains.	<ol style="list-style-type: none"> 1. Iron or manganese in water supply, water pipes, or water heater. 	<ol style="list-style-type: none"> 1. To restore discolored load of whites, use rust remover safe for fabric. 2. Do not use chlorine bleach to remove rust stains. It may intensify discoloration. 3. Use nonprecipitating water softener. 4. Before washing, run hot water for a few minutes to clear lines. 5. Drain water heater occasionally. 6. For an ongoing problem, install an iron filter in the water supply system.

Section 5 Troubleshooting

The following troubleshooting chart involves common concerns that are not the result of defective workmanship or materials in this washer. Some problems below involve improper installation and issues arising from the users household water supply. See the Use and Care guide for the unit in question and the Installation Section in this manual.

Problem	Cause	Correction
High pitch "jet engine" noise.	1. A certain amount of motor whine is normal during the spin cycle.	1. This is normal operation of the unit.
Rattling and clanking noise.	1. Foreign objects such as coins or safety pins maybe in drum or pump. 2. Belt buckles and metal fasteners are hitting wash drum.	1. Stop washer and check drum. If noise continues after washer is restarted, objects may be in pump 2. To prevent unnecessary noise and damage to drum, fasten fasteners and turn items inside out.
Squealing sound or hot rubber odor.	1. Washer is overloaded.	1. Stop washer and reduce load.
Thumping sound.	1. Heavy wash loads may produce a thumping sound. 2. Washer is out of balance.	1. This is usually normal. 2. Stop washer and redistribute wash load.
Vibrating noise.	1. Washer is not resting firmly on floor. 2. Shipping bolts and foam blocks have not been removed during installation. 3. Wash load unevenly distributed in drum.	1. Adjust leveling legs. See Installation Section 2. See Installation Section for removing shipping bolts and foam blocks. 3. Stop washer and redistribute wash load.
Washer does not start.	1. Electrical power cord may not be plugged in or connection may be loose. 2. House fuse blown, circuit breaker tripped, or a power outage has occurred. 3. Water supply faucets are not turned on. 4. Motor is overheated. 5. Dispenser drawer is not completely closed.	1. Make sure plug fits tightly in wall outlet. 2. Reset circuit breaker or replace fuse. Do not increase fuse capacity. If problem is a circuit overload, have it corrected by a qualified electrician. If problem is a power outage, call local electric company. 3. Turn on water supply faucets. 4. Washer motor will stop if it becomes over heated. It will automatically restart after a cool down period of up to 30minutes (if washer has not been manually turned off). 5. Close dispenser drawer.
Washer won't spin.	1. Washer door is not completely closed. 2. Dispenser drawer is not completely closed. 3. Load is too small.	1. Close door completely. 2. Close dispenser drawer. 3. Add 1 or 2 similar items to help balance the load.
Incorrect wash and rinse temperatures.	1. Hot and cold water hoses are connected to wrong supply faucets.	1. Connect hot water hose to hot water faucet and cold water hose to cold water faucet.

Section 5 Troubleshooting

Problem	Cause	Correction
Residue left in drum.	1. Heavily soiled items.	1. Heavily soiled items. Wipe drum with a nonabrasive household cleanser, then rinse. Shake or brush excess dirt and sand from items before washing.
Water collects in bleach and fabric softener compartments.	1. This is a result of the siphoning action and is part of the normal operation of the washer.	1. Water may be removed by removing the dispenser drawer and draining water into the empty drum or sink.
Wash load too wet after spin.	1. Washer is overloaded. 2. Load is too small. 3. Load is out of balance. 4. Drain hose is kinked.	1. Do not overload washer. 2. Add 1 or 2 similar items to help balance the load. 3. Rearrange load to allow proper spinning. 4. Straighten drain hose.
Water does not enter washer or it enters slowly.	1. Water supply is not adequate in area. 2. Water supply faucets are not completely open. 3. Water is being used elsewhere in the house. 4. Water inlet hoses are kinked. 5. Water inlet screens plugged.	1. Check another faucet in the house. Wait until water supply and pressure increase. 2. Fully open hot and cold faucets. 3. Water pressure must be at least 30 psi (260 kPa). Avoid running water elsewhere while washer is filling. 4. Straighten hoses. 5. Clean screens.
Warm or hot water is not hot enough.	1. Hot water heater is set too low or is a distance from washer. 2. Hot water is being used elsewhere in the house.	1. Measure hot water temperature at nearby faucet with candy or meat thermometer. Water temperature should be at least 120°F (49°C). Adjust water heater as necessary. 2. Avoid using hot water elsewhere before or during washer use. There may not be enough hot water available for proper cleaning. If problem persists, the hot water system may be unable to support more than 1 use at a time.
Water in washer does not drain or drains slowly.	1. Drain hose is kinked or clogged.	1. Clean and straighten the drain hose. 2. Maximum standpipe height is 8' (2.4 m).
Water leaks.	1. Fill hose connection is loose at faucet or washer. 2. House drain pipes are clogged.	1. Check and tighten hose connections. Install rubber sealing washers provided. 2. Unclog drain pipes. Contact plumber if necessary.
Oversudsing.	1. Wrong detergent. 2. Too much detergent.	1. Run rinse cycle. Use a low-sudsing, high efficiency detergent. 2. Run rinse cycle. Use less detergent in future loads.
Water is entering washer but tub does not fill.	1. Drain hose standpipe is incorrect height.	1. Standpipe must be a minimum of 24" (61 cm) high to prevent siphoning. See Installation Section.

Section 6 Wiring Diagrams

Affinity 7000 Series Wiring Diagram

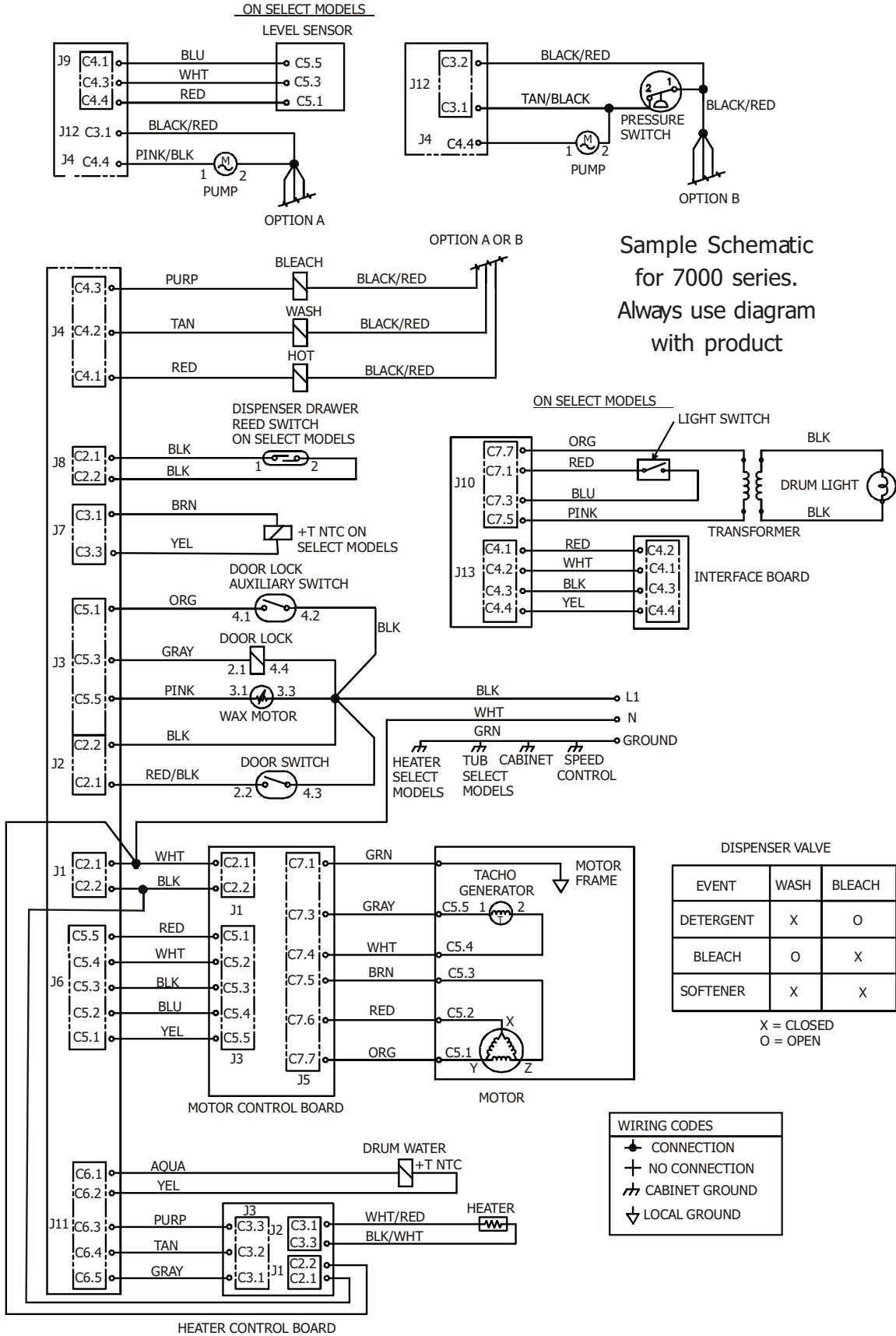

Section 6 Wiring Diagrams

Affinity 6000 Series Wiring Diagram

