



ELECTROLUX HOME PRODUCTS NORTH AMERICA

# ***SERVICE MANUAL***

***Laundry Center***

***With***

***Tumble Action Washers***

*Frigidaire*

***TAPPAN***

***W*** White-Westinghouse

**Gibson**

***Kelvinator*** 

59955406146

May 2004

# SAFE SERVICING PRACTICES - ALL APPLIANCES

To avoid personal injury and/or property damage, it is important that **Safe Servicing Practices** be observed. The following are some limited examples of safe practices:

1. **DO NOT** attempt a product repair if you have any doubts as to your ability to complete it in a safe and satisfactory manner.
2. Before servicing or moving an appliance:
  - Remove the power cord from the electrical outlet, trip the circuit breaker to the OFF position, or remove the fuse.
  - Turn off the gas supply.
  - Turn off the water supply.
3. Never interfere with the proper operation of any safety device.
4. **USE ONLY REPLACEMENT PARTS CATALOGED FOR THIS APPLIANCE. SUBSTITUTIONS MAY DEFEAT COMPLIANCE WITH SAFETY STANDARDS SET FOR HOME APPLIANCES.**
5. **GROUNDING:** The standard color coding for safety ground wires is **GREEN**, or **GREEN with YELLOW STRIPES**. Ground leads are not to be used as current carrying conductors. It is **EXTREMELY** important that the service technician reestablish all safety grounds prior to completion of service. Failure to do so will create a hazard.
6. Prior to returning the product to service, ensure that:
  - All electrical connections are correct and secure
  - All electrical leads are properly dressed and secured away from sharp edges, high-temperature components, and moving parts
  - All non-insulated electrical terminals, connectors, heaters, etc. are adequately spaced away from all metal parts and panels
  - All safety grounds (both internal and external) are correctly and securely connected
  - All panels are properly and securely reassembled

## ATTENTION!!!

This service manual is intended for use by persons having electrical and mechanical training and a level of knowledge of these subjects generally considered acceptable in the appliance repair trade. Electrolux Home Products cannot be responsible, nor assume any liability, for injury or damage of any kind arising from the use of this manual.

<b>SAFE SERVICING PRACTICES</b> _____	<b>2</b>
<b>QUICK REFERENCE SHEET</b> _____	<b>9</b>
Serial nameplate location _____	9
Serial number breakdown _____	9
Tech sheet location _____	9
<b>Washer section</b> _____	<b>10</b>
Component resistance chart _____	10
Water fill height _____	10
Electrical requirements (Gas laundry center) _____	10
Electrical requirements (Electric laundry center) _____	10
Incoming water pressure _____	10
Drain requirements _____	10
Motor _____	10
Operation speeds _____	11
Tub pulley to motor pulley ratio _____	11
Tub capacity _____	11
<b>Dryer section specification</b> _____	<b>12</b>
Electrical _____	12
Drum _____	12
Airflow CFM _____	12
Drum temperatures _____	12
Dimension _____	12
Vent capability _____	12
Component resistances _____	12
Drive motor _____	12
Timer motor _____	12
Heating element _____	12
Bias heater on thermostat _____	12
Burner assembly _____	12
Sample wiring diagram for dryer section gas models _____	13
Sample wiring diagram for dryer section electric models _____	14
Dryer cycle chart _____	15
Sample wiring diagram for washer section _____	16
Washer timer chart _____	17
<b>SECTION A - INSTALLATION INSTRUCTIONS</b> _____	<b>18</b>
What to do if you smell gas _____	18
Pre-installation requirements _____	18
Tools required for installation _____	18
<b>Electrical requirements (Electric laundry center)</b> _____	<b>18</b>
Circuit _____	18
Power supply _____	18
Power supply cord kit _____	18
Outlet receptacle _____	18
<b>Electrical requirements (Gas laundry center)</b> _____	<b>18</b>
Circuit _____	18
Power supply _____	19
Power supply cord _____	19
Outlet receptacle _____	19
Water supply requirements _____	19
Drain requirements _____	19
Exhaust system requirements _____	19
Gas supply requirements _____	21
Location of your laundry center _____	21
Do not install your laundry center _____	21
Installation in recess or closet _____	21
Mobile home installation _____	22
Unpacking _____	22

Rough-in dimensions _____	23
Electrical installation _____	24
Grounding requirements _____	24
Electrical connections for A 3-wire system _____	25
Electrical connections for A 4-wire system _____	25
Installation _____	26
Replacement parts _____	27
<b>SECTION B - DRYER OPERATING INSTRUCTIONS _____</b>	<b>28</b>
Before operating your dryer _____	28
Operating steps _____	28
Cycle selection _____	28
Automatic dry cycle _____	28
Air fluff cycle _____	29
Timed dry cycle _____	29
Energy saving tips _____	29
<b>SECTION C - WASHER OPERATING INSTRUCTIONS _____</b>	<b>30</b>
Before operating your washer _____	30
Operating steps _____	30
Cycle selection _____	30
Whites/regular cycle _____	30
Short wash cycle _____	31
Colors/perm press cycle _____	31
Knits and delicates cycle _____	31
Controls _____	31
Temperatures _____	31
Cycle signal _____	31
Extra rinse _____	31
Final spin _____	31
<b>SECTION D - OWNER GUIDE _____</b>	<b>32</b>
For your safety _____	32
Product registration _____	32
Important safety instructions _____	32
Prevent fire _____	32
Gas laundry centers _____	33
For your safety _____	33
Protect children _____	33
Prevent injury _____	33
Washing procedures _____	34
Sort laundry _____	35
Prepare items for washing _____	35
Pretreat stains _____	35
Add detergent, bleach and fabric softener _____	36
Set cycle selector knob and washer controls _____	37
Start the washer _____	37
Remove items when the cycle is completed _____	38
General precautions _____	38
Stain removal _____	38
Safe stain removal procedures _____	38
For successful stain removal _____	39
Stain removal _____	39
Common washing problems _____	40
Drying procedures _____	41
Prepare items for drying _____	41
Check that lint screen is clean and in place _____	41
Load the dryer _____	41
Close the dryer door and set dryer controls _____	42
Turn cycle selector clockwise to the desired setting _____	42



Start the dryer _____	42
When the cycle ends, remove items immediately _____	42
Features _____	42
Cycle signal control (some models) _____	42
Drum light (some models) _____	42
Drying rack (some models) _____	42
Common drying problems _____	43
Care and cleaning _____	44
Cleaning the dispenser drawer area _____	44
Inside _____	44
Inside the dryer _____	45
Outside _____	45
Winterizing instructions _____	46
Avoid service checklist _____	46
Sample warranty _____	50
<b>SECTION E - DRYER SECTION OPERATION _____</b>	<b>51</b>
Airflow electric dryers _____	51
Airflow gas dryers _____	52
Airflow problems _____	52
Restrictions _____	53
Air leaks _____	53
Short unrestricted vents _____	53
Electrical operation (electric dryer) _____	53
Automatic dry cycle _____	54
Drive motor circuit _____	54
The timer motor circuit _____	54
Automatic press saver option _____	55
The heating circuit _____	55
The cycle signal circuit _____	55
Timed dry cycle _____	55
The timer motor circuit _____	55
Drive motor and heating circuits _____	56
Air fluff cycle _____	56
The timer motor circuit _____	56
Drive motor circuit _____	56
The heating circuit _____	56
Electrical operation (gas dryer) _____	56
Automatic dry cycle _____	56
Drive motor circuit _____	56
The timer motor circuit _____	57
Automatic press saver option _____	57
The heating circuit _____	57
The cycle signal circuit _____	59
Timed dry cycle _____	59
The timer motor circuit _____	59
Drive motor and heating circuits _____	59
Air fluff cycle _____	59
The timer motor circuit _____	59
Drive motor circuit _____	59
The heating circuit _____	59
<b>SECTION F - WASHER SECTION OPERATION _____</b>	<b>60</b>
Timer _____	60
Line switch _____	60
Dispenser drawer reed switch _____	60
Door switch assembly _____	61
Pressure switch _____	62
Automatic dispenser _____	62

Temperature switch _____	64
Water inlet valve _____	64
Valve operation _____	65
Extra rinse switch _____	66
<b>SECTION G - TROUBLESHOOTING FLOW CHARTS _____</b>	<b>68</b>
Dryer section index _____	68
Washer section index _____	69
Electric dryer completely inoperative _____	70
Gas dryer completely inoperative _____	71
Electric and gas dryers; timer advances in timed dry but not in auto dry _____	72
Electric and gas dryers; timer does not pause in auto dry with wet clothes in the dryer _____	72
Electric and gas dryers blower motor runs but drum does not turn _____	73
Electric and gas dryers longer than normal drying times _____	73
Electric dryers blower motor runs but dryer does not heat _____	74
Gas dryers blower motor runs but dryer does not heat _____	75
Electric dryers blower motor runs but timer does not advance in auto or timed dry _____	76
Electric and gas dryers dryer over heating _____	76
Electric and gas dryers timer advances in auto dry but not in timed dry _____	76
Speed control and motor plug and pin layout _____	77
Washer completely inoperative _____	78
Timer does not advance _____	78
Washer does not drain _____	79
Extra rinse setting does not work _____	79
Bleach dispenser does not operate _____	80
Softener dispenser does not operate _____	80
Drive motor does not turn _____	81
Drive motor spins but does not tumble _____	82
Drive motor tumbles but does not spin _____	82
Drive motor tumbles very slowly in any timer position _____	83
Spin cycle operating at incorrect speed for switch setting _____	83
Water fill does not turn off _____	84
Incorrect water level _____	84
Slow water fill _____	85
Door indicator lamp does not glow _____	85
Washer will not fill in any setting of the temp switch _____	86
Water temperature is too hot or too cold in the wash cycle with the temp switch set to warm/warm _____	87
Washer will only fill with hot water in the wash cycle, with the temp switch set to warm/cold but does fill with cold in the rinse cycle _____	87
<b>SECTION H - TEARDOWN _____</b>	<b>88</b>
Removing the knobs _____	88
All knobs except the washer timer knob _____	88
Removing timer bezel _____	88
Removing the access panel _____	88
Opening the console _____	89
Removing the dryer timer _____	89
Removing the dryer buzzer _____	89
Removing the console end caps _____	90
Removing the console front panel _____	90
Removing the start switch _____	90
Removing the temperatures switch _____	91
Removing the automatic press saver switch _____	91
Removing the water temperature switch _____	91
Removing the extra rinse switch _____	91

The door lock lamp assembly _____	92
Removing the door lock lamp assembly _____	92
Removing the washer buzzer _____	92
Removing the final spin speed switch _____	92
Removing the washer timer _____	93
Removing the electronic moisture sensor control _____	93
Removing the dryer door _____	93
Separating the dryer door panel _____	93
Removing the dryer door seal _____	94
Removing the dryer door heat shield _____	94
Removing the dryer door handle _____	94
Removing the dryer door strike _____	95
Removing the dryer door hinge _____	95
Removing the dryer door switch _____	95
Removing the heat shield _____	95
Removing the dryer front panel _____	95
Replacing the felt seals _____	96
Replacing the front duct _____	96
Removing the door catch _____	96
Replacing the foam seal _____	96
Removing the dryer section rear access panel _____	97
Releasing the dryer belt _____	97
Removing the idler pulley _____	97
Removing the idler pulley assembly _____	97
Removing the belt _____	98
Removing the control thermostat and thermostat heater _____	98
Removing the sensor (Gas dryers) _____	98
Removing combustion chamber shield (Gas dryers) _____	98
Removing the burner (Gas dryers) _____	99
Removing the ignitor (Gas dryers) _____	99
Removing the gas valve coils (Gas dryers) _____	99
Removing the burner and combustion chamber assembly, manual shut off and the internal gas pipe (Gas dryers) _____	99
Removing manual shut off and internal gas pipe (Gas dryers) _____	100
Removing pressure regulator valve assembly (Gas dryers) _____	100
Removing the combustion chamber (Gas dryers) _____	100
Removing the dryer top panel _____	100
Removing the vane from the dryer drum _____	101
Removing the dryer drum _____	101
Removing the ball hitch from the drum _____	101
Removing the teflon glides _____	101
Removing the drum heat shield (Electric dryers) _____	101
Removing the hitch _____	102
Removing the high limit thermostat _____	102
Removing the thermal limiter (Electric dryers) _____	102
Removing the heating element assembly (Electric dryers) _____	102
Removing the duct and heat shield (Gas dryers) _____	103
Removing the blower and motor assembly _____	103
Disassembling the blower and motor assembly _____	104
Removing the internal vent duct _____	105
Removing the motor and blower assembly base _____	105
Removing the burner assembly base (Gas dryers) _____	106
Removing the dryer section side panels _____	106
Removing the dryer section _____	107
Removing the detergent drawer _____	108
Detergent drawer disassembly _____	108
Removing the washer section top panel _____	109

Removing the top panel spacers _____	109
Removing the washer section upper front panel _____	109
Removing the reed switch _____	110
Removing the front service panel _____	110
To remove loading door and hinge _____	111
Disassembling the door _____	111
To remove door strike _____	112
Removing the door safety switch _____	112
Removing the bellows (door boot) _____	113
Reinstalling or replacing the boot _____	114
Removing the water inlet duct _____	117
Removing the detergent dispenser solenoid assembly _____	117
Removing the detergent cavity assembly _____	117
Removing the pressure switch _____	118
Removing the suspension springs _____	118
Removing the water inlet valve _____	119
Removing the drain pump assembly _____	119
Disassembling the drain pump _____	120
To remove the air bell _____	120
Removing the back service panel _____	121
Removing the speed control board assembly _____	121
Drive belt _____	122
To remove or replace the drive belt _____	122
Removing the drive motor _____	122
Removing the large pulley _____	122
Removing the rear counter weight _____	122
Removing the air shock absorber _____	123
Removing the outer tub _____	123
Removing the spin basket and rear tub half _____	123
Removing the front counter weights _____	124
Removing the spin basket vanes _____	124
Removing the spacers between the dryer section and the washer section _____	124
Removing the mounting brackets _____	125

## QUICK REFERENCE SHEET

1. Serial nameplate location: on the inner panel of the dryer section door.



2. Serial number breakdown.

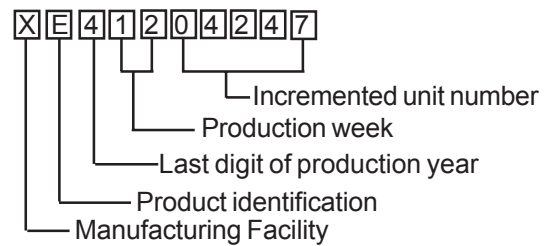

3. Tech sheet location

Behind the access panel.

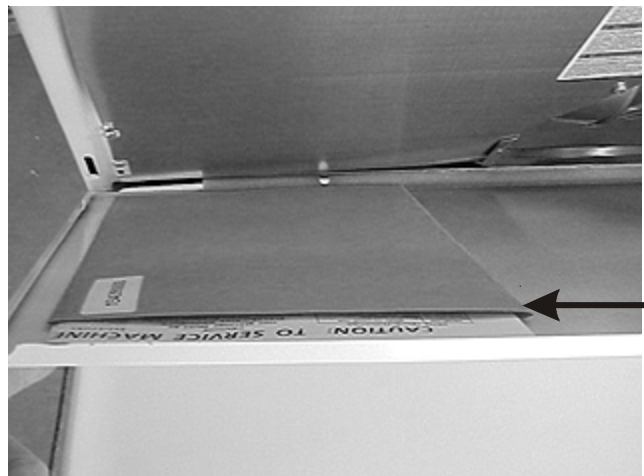

## QUICK REFERENCE SHEET (Washer Section)

Component resistance chart.

Electrical component		Resistance $\Omega$ @ 77° F (25°C)
Water valve solenoids		880 $\pm$ 10%
Door lock solenoid		1325 $\pm$ 75 Ohms
Timer motor		2425 $\pm$ 6%
Pump motor		15 $\pm$ 7%
Dispenser valve solenoids		1100 $\pm$ 7%
Motor	M1 TO M2	2.6 $\pm$ 7%
	M2 TO M3	2.6 $\pm$ 7%
	M1 TO M3	2.6 $\pm$ 7%
	M5 TO M6	184 $\pm$ 7%

Water fill height 2.03  $\pm$  0.80 " No load,  
start position of heavy wash  
and 2.53  $\pm$  0.53" No load at the start  
position of all other cycles.

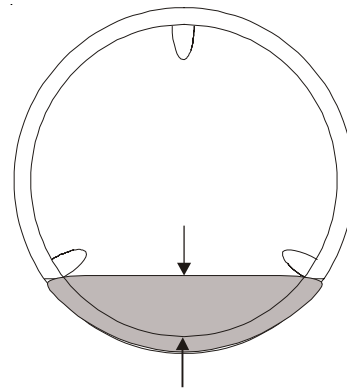

Electrical requirements. (Gas laundry center)

Circuit - Individual, properly polarized and grounded 15 amp. branch circuit fused with 15 amp. time delay fuse or circuit breaker.

Electrical requirements. (Electric laundry center)

Circuit - Individual 30 amp branch circuit fused with 30 amp minimum time delay fuses or circuit breakers.

Incoming water pressure.

30 and 120 pounds per square inch (maximum unbalance pressure, hot vs. cold, 10 psi.)

Drain requirements.

Drain capable of eliminating 17 gals (64.3 L) per minute.

A standpipe diameter of 1-1/4 in. (3.18 cm) minimum.

The standpipe height above the floor should be:

Minimum height: 24 in. (61 cm)

Maximum height: 96 in. (244 cm)

Drive motor.

Agitate wattage - Max 200

Spin wattage - Max 475

## Operation speeds: (Washer Section)

Agitate Speed - RPM (Regular/Perm Press)	51 ± 4
Agitate Speed - RPM (Knits/Delicates/Hand Washables)	35 ± 4
Spin speeds	
Regular Cycle	
Spin Speed R.P.M. (Normal)	900 ± 39
Spin Speed R.P.M. (Fast)	950 ± 39
Perm Press Cycle	
Spin Speed R.P.M. (Normal)	650 ± 39
Spin Speed R.P.M. (Fast)	900 ± 39
Knits/Delicates/Hand Washables Cycle	
Spin Speed R.P.M. (Normal)	450 ± 25
Spin Speed R.P.M. (Fast)	650 ± 30
Tub Pulley to Motor Pulley Ratio	16 TO 1
Tub Capacity	2.65 cu. ft.

**QUICK REFERENCE SHEET  
DRYER SECTION**

<b>SPECIFICATION</b>	<b>ELECTRIC MODELS</b>	<b>GAS MODELS</b>
<b>Electrical</b>		
Volts 120/208 or 120/240	120/208 or 120/240	120
Amps (circuit)	30	15
Motor wattage	160-350 Watts	160-350 Watts
Heat input (Watts @ 240VAC)	3200/4500	—
Heat input (BTU/Hr.)	—	20,000
Auto. Elec. Ignition	—	Yes
<b>Drum</b>		
Size (Cu. Ft.)	5.7	5.7
Finish	Stainless steel	Stainless steel
R.P.M.	48 - 54	48 - 54
<b>Airflow CFM</b>	180	180
<b>Drum temperatures (Max. opening on 1st cycle)</b>		
High	155° - 225°	150° - 220°
Medium	150° - 210°	140° - 215°
Low	145° - 205°	135° - 195°
<b>Dimension (Inches)</b>		
Height	75 1/4"	75 1/4"
Width	27"	27"
Depth	30 13/16"	30 13/16"
<b>Vent capability</b>	4-Way	4-Way

<b>Component resistances*</b>	<b>Electric Models</b>	<b>Gas Models</b>
<b>Drive motor (120 volt, 60 Hz, 1/4 h.p. 1725 rpm)</b>		
Motor Start Winding	4.5 Ohms	4.5 Ohms
Motor Run Winding	3.8 Ohms	3.8 Ohms
<b>Timer motor</b>	2280-2300 Ohms	2280-2300 Ohms
<b>Heating element</b>	12.8 Ohms	
<b>Bias heater on thermostat</b>	7,200 Ohms	2,000 Ohms
<b>Burner assembly</b>		
Ignitor	—	50 - 400 Ohms
Secondary Coil	—	1200 Ohms
Booster Coil	—	1320 Ohms

\* +/- 10% @ 77° F



# SAMPLE WIRING DIAGRAM FOR DRYER SECTION GAS MODELS

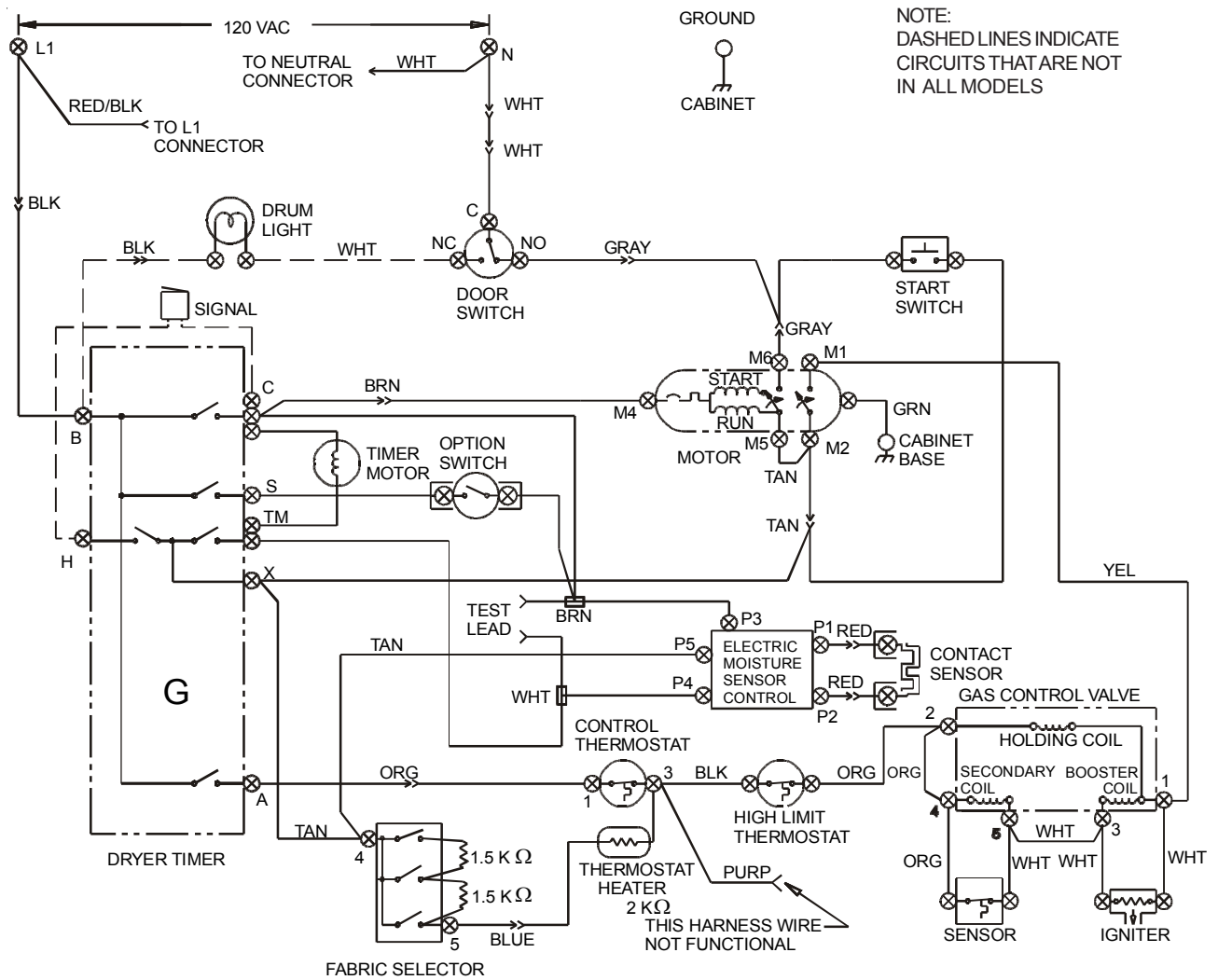

WIRING CODES	
	QUICK DISCONNECT TERMINAL
	SCREW TERMINAL
	CONNECTION
	NO CONNECTION
	MOTOR SWITCH
	SPLICE
	MOTOR PROTECTOR
	CHASSIS (CABINET) GROUND
	HARNES CONNECTOR TERMINAL
	INSULATED TERMINAL

FABRIC SELECTOR SWITCH - GAS MODELS

POSITION	FUNCTION	RESISTANCE $\Omega$
1	HIGH	OPEN CIRCUIT
2	MEDIUM	3K+/- 5%
3	MEDIUM/LOW	1.5K+/- 5%
4	LOW	10 MAX

### NOTES - GAS MODELS

- 1 - ALL WIRING MUST CONFORM TO LOCAL ELECTRICAL CODE.
- 2 - CONNECT DRYER TO 15 AMP INDIVIDUAL BRANCH CIRCUIT.
- 3 - DRYER TIMER SHOWN IN THE OFF POSITION DOOR SWITCH CLOSED, MOTOR AT REST, THERMOSTAT CLOSED, AND FABRIC SELECTOR SWITCH AT HIGH HEAT.

# SAMPLE WIRING DIAGRAM FOR DRYER SECTION ELECTRIC MODELS

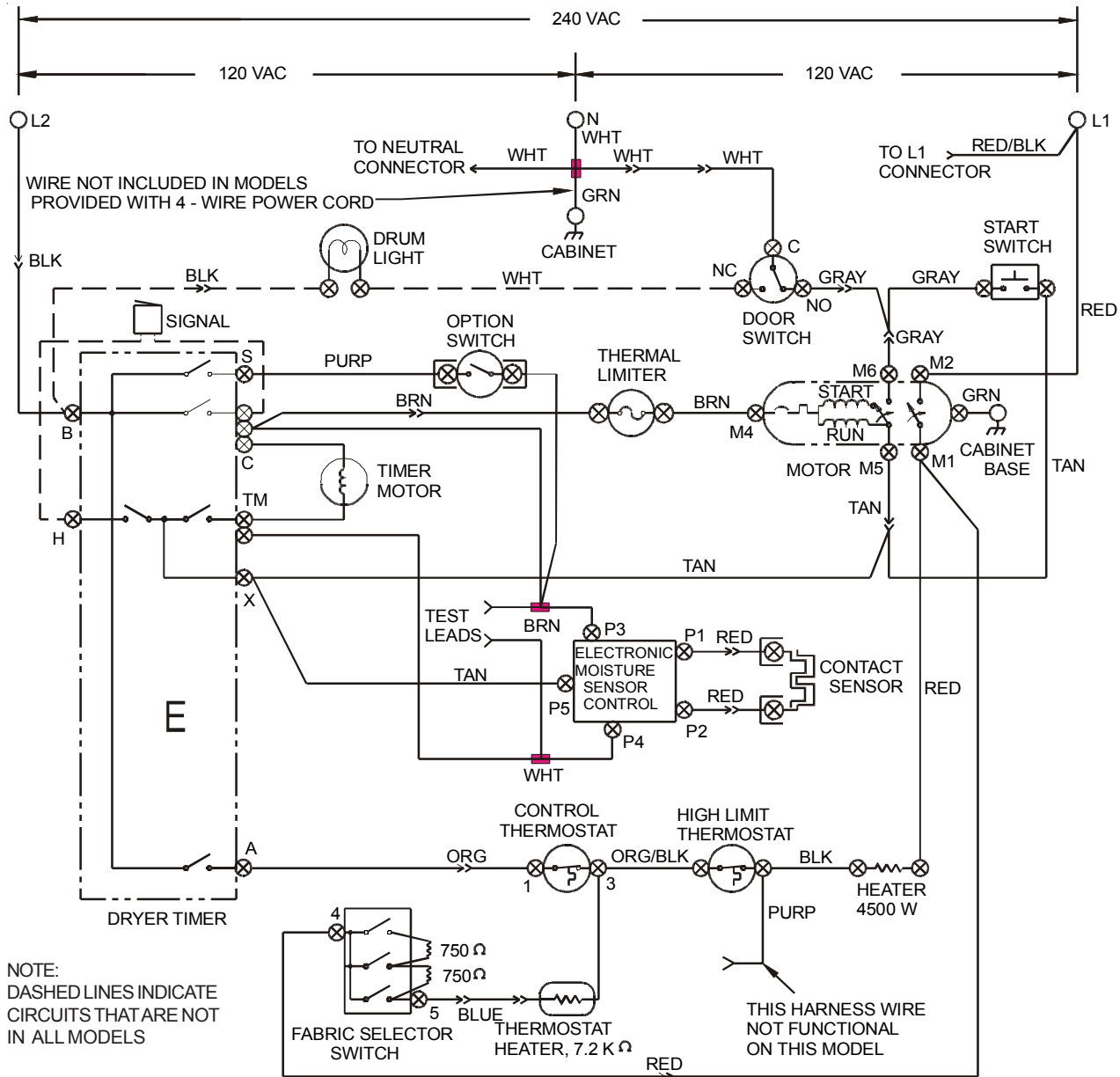

NOTE:  
DASHED LINES INDICATE  
CIRCUITS THAT ARE NOT  
IN ALL MODELS

WIRING CODES	
	QUICK DISCONNECT TERMINAL
	SCREW TERMINAL
	CONNECTION
	NO CONNECTION
	MOTOR SWITCH
	SPLICE
	MOTOR PROTECTOR
	CHASSIS (CABINET) GROUND
	HARNESS CONNECTOR TERMINAL
	INSULATED TERMINAL

### FABRIC SELECTOR SWITCH - ELEC MODELS

POSITION	FUNCTION	RESISTANCE (4-5)
1	HIGH	OPEN CIRCUIT
2	MEDIUM	1.5K +/-5%
3	MEDIUM/LOW	750 +/-5%
4	LOW	10 MAX

### NOTES - ELEC MODELS

- 1 - ALL WIRING MUST CONFORM TO LOCAL ELECTRICAL CODE.
- 2 - CONNECT LUNDRY CENTER TO 30 AMP INDIVIDUAL BRANCH CIRCUIT.
- 3 - DRYER TIMER SHOWN IN THE OFF POSITION DOOR SWITCH CLOSED, MOTOR AT REST, THERMOSTAT CLOSED, AND FABRIC SELECTOR SWITCH AT HIGH HEAT.

## GAS & ELECTRIC DRYER CYCLE CHART

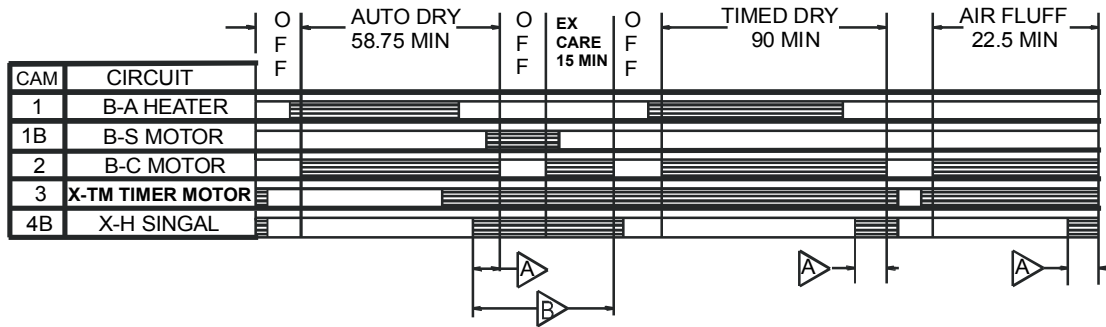

1. THE BAR CHART ABOVE REPRESENTS ONE COMPLETE REVOLUTION OF THE TIMER SHAFT.
2. SHADE PORTION OF THE BAR CHART INDICATES THE PROPORTIONAL TIMES THAT THE INTERNAL TIMER CONTACTS ARE CLOSED.
3. SIGNAL:

- A**    CIRCUIT "X - H" WILL CLOSE FOR 5 SEC +/- 3 SEC 1 TO 2 TIMES IN THIS AREA. WHEN 2 CLOSURES OCCUR THEY WILL BE 5 MIN APART.
- B**    CIRCUIT "X - H" WILL CLOSE FOR 5 SEC +/- 3 SEC 5 TO 7 TIMES IN THIS AREA. CLOSURES WILL BE 5 MIN APART.

## SAMPLE WIRING DIAGRAM WASHER SECTION

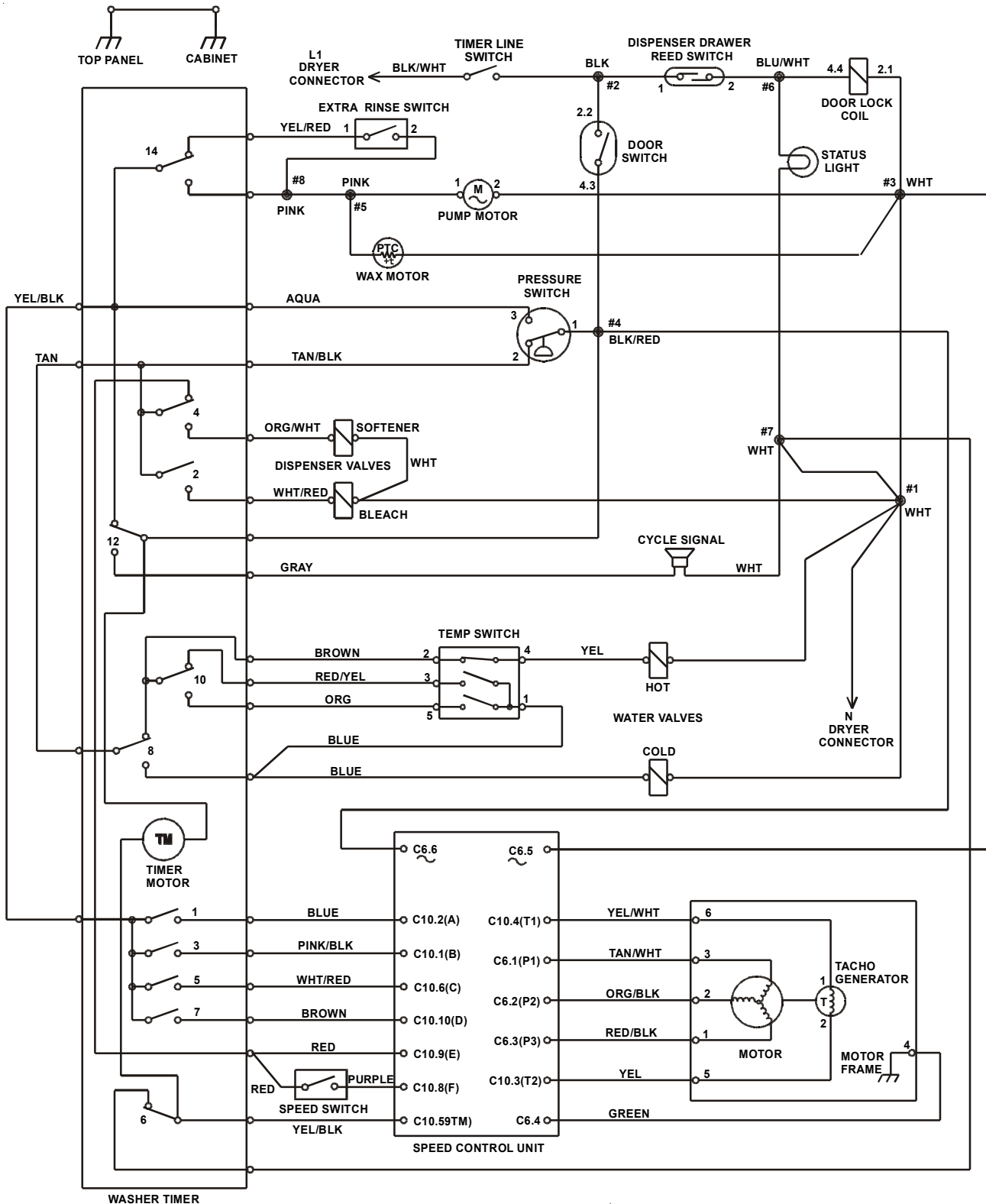

**WASHER TIMER SHOWN IN OFF POSITION  
DISPENSER DRAWER OPEN, & DOOR OPEN**

SPEED SWITCH	
SPEED	1 - 2
NORMAL	CLOSED
FAST	OPEN

TEMPERATURE SWITCH CIRCUIT			
WASH/RINSE	1 - 3	1 - 5	2 - 4
HOT/COLD			X
WARM/COLD		X	X
COLD/COLD		X	
WARM/WARM (OPT)	X	X	X

X=CONTACTS CLOSED



## Section A - Installation Instructions Tumble Action Laundry Center

### Gas & Electric

**Before beginning installation, carefully read these instructions. This will simplify the installation and ensure the laundry center is installed correctly and safely. Leave these instructions near the laundry center after installation for future reference.**

**NOTE: The electrical service to the laundry center must conform with local codes and ordinances and the latest edition of the National Electrical Code, ANSI/NFPA 70, or in Canada, the Canadian Electrical Code, CSA C22.1**

**NOTE: The gas service to the laundry center must conform with local codes and ordinances and the latest edition of the National Fuel Gas Code ANSI Z223.1/NFPA 54, or in Canada, the Canadian Natural Gas and Propane Installation Code, CSA B149.1.**

**NOTE: The laundry center is designed under ANSI Z21.5.1 or ANSI/UL 2158- CAN/CSA C22.2 (latest edition) for HOME USE only. This laundry center is not recommended for commercial applications such as restaurants or beauty salons, etc.**

**WARNING** For your safety the information in this manual must be followed to minimize the risk of fire or explosion or to prevent property damage, personal injury or loss of life.

- Do not store or use gasoline or other flammable vapors and liquid in the vicinity of this or any other appliance.

#### WHAT TO DO IF YOU SMELL GAS

- Do not try to light any appliance.
- Do not touch any electrical switch; do not use any phone in your building.
- Clear the room, building or area of all occupants.
- Immediately call your gas supplier from a neighbor's phone. Follow the gas supplier's instructions.
- If you cannot reach your gas supplier, call the fire department.

Installation and service must be preformed by a qualified installer, service agency or the gas supplier.

### PRE-INSTALLATION REQUIREMENTS

#### Tools and Materials Required for Installation:

1. Phillips head screwdriver
2. Channel-lock adjustable pliers

3. Carpenter's level
4. Flat or straight blade screwdriver
5. Duct tape
6. Rigid or flexible metal 4 inch (10.16 cm) duct
7. Vent hood
8. Pipe thread sealer (Gas)
9. 1/4 inch socket w/ratchet
10. 3/8 inch socket w/ratchet
11. 3/8 inch open end wrench
12. 7/16 inch open end wrench
13. 9/16 inch open end wrench

### ELECTRICAL REQUIREMENTS

#### **ELECTRIC Laundry Center**

**Circuit-** Individual 30 amp branch circuit fused with 30 amp minimum time delay fuses or circuit breakers.

**POWER SUPPLY** - 3-wire or 4-wire, 240 volt, single phase, 60 Hz, Alternating Current.

**POWER SUPPLY CORD KIT-** The laundry center **MUST** employ a 3-conductor power supply cord NEMA 10-30 type SRDT rated at 240 volt AC minimum, 30 amp, with 3 open end spade lug connectors with upturned ends or closed loop connector **OR** a 4-conductor power supply cord NEMA 14-30 type SRDT or ST (as required) rated at 240 volt AC minimum, 30 amp, with 4 open end spade lug connectors with upturned ends or closed loop connectors and marked for use with clothes dryers. If being installed in a manufactured (mobile) home, the laundry center **MUST** employ a 4-conductor power supply cord NEMA 14- 30 type SRDT or ST (as required) rated at 240 volt AC minimum, 30 amp, with 4 open end spade lug connectors with upturned ends or closed loop connectors and marked for use with clothes dryers. See ELECTRICAL CONNECTIONS. (Canada -4- wire power supply cord is installed on laundry center.)

**OUTLET RECEPTACLE** - NEMA 10-30R (3-wire) receptacle or NEMA 14- 30R (4-wire) receptacle to be located so the power supply cord is accessible when the laundry center is in an installed position.



NEMA 10-30R



NEMA 14-30R

#### **GAS Laundry Center**

**CIRCUIT** - Individual 15 amp branch circuit fused with a 15 amp maximum time delay fuse or circuit breaker.

**POWER SUPPLY** -3 wire, 120 volt single phase, 60 Hz, Alternating Current.

**POWER SUPPLY CORD** -The gas laundry center is equipped with a 120 volt 3-wire power cord.

**OUTLET RECEPTACLE** - Properly grounded 3-prong receptacle to be located so the power supply cord is accessible when the washer is in an installed position. NOTE: GFI (Ground Fault Interrupter) receptacle is not required or recommended.

**Note: Do not under any circumstances remove grounding prong from plug.**

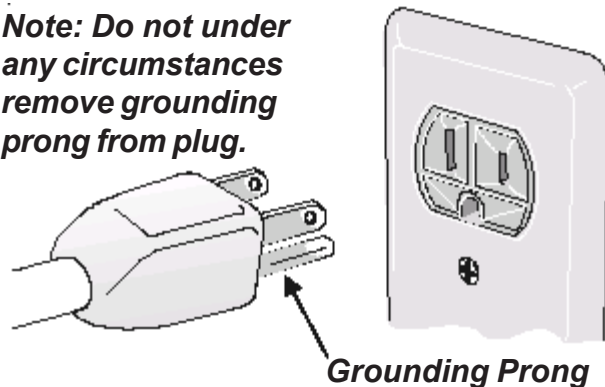

#### WATER SUPPLY REQUIREMENTS

Hot and cold water faucets **MUST** be installed within 42 inches (106.68 cm) of your laundry center's water inlet. The faucets **MUST** be 3/4 inch (1.9 cm) garden hose type so inlet hoses can be connected. Water pressure **MUST** be between 10 and 120 pounds per square inch (maximum unbalance pressure, hot vs. cold, 10 psi). Your water department can advise you of your water pressure. The hot water temperature should be about 140 degrees F.

#### DRAIN REQUIREMENTS

1. Drain capable of eliminating 17 gallons per minute.
2. A standpipe diameter of 1¼ inches (3.18 cm) minimum.

3. The standpipe height above the floor should be:  
Minimum height: 24 inches (61 cm)  
Maximum height: 96 inches (244 cm)

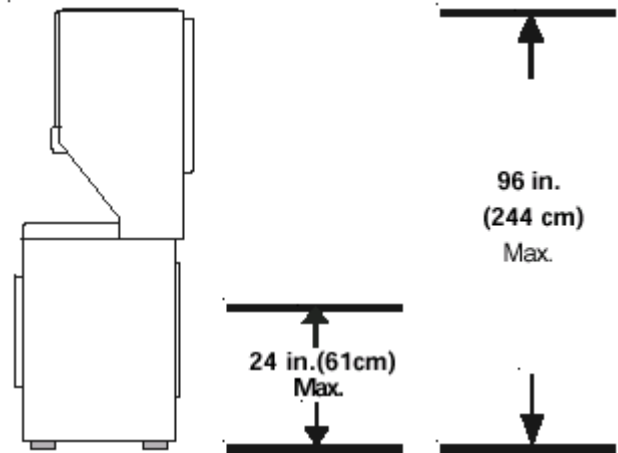

**NOTE:** For installations requiring a longer drain hose, have a qualified technician install a longer hose, Part Number 134042901, available from an authorized parts distributor. For drain systems in the floor, install a siphon break kit, available from your local hardware store .

#### EXHAUST SYSTEM REQUIREMENTS

Use only 4 inch (10.16 cm) diameter (minimum) rigid or flexible metal duct and approved vent hood which has a swing-out damper(s) that opens when the dryer is in operation. When the dryer stops, the damper(s) automatically closes to prevent drafts and the entrance of insects and rodents. To avoid restricting the outlet, maintain a minimum of 12 inches (38.5 cm) clearance between the vent hood and the ground or any other obstruction.

**⚠ WARNING** *The following are specific requirements for proper and safe operation of your laundry center. Failure to follow these instructions can create excessive drying times and fire hazards.*

**⚠ WARNING** *Do not use plastic flexible duct to exhaust the dryer. Excessive lint can build up inside the exhaust system and create a fire hazard and restrict air flow. Restricted air flow will increase drying times. If your present system is made up of plastic duct or metal foil duct, replace it with a rigid or flexible metal duct. **Ensure the present duct is free of any lint prior to installing the laundrycenter dryer duct.***

**⚠ WARNING** *If the dryer is not exhausted outdoors, some fine lint will be expelled into the laundry area. An accumulation of lint in any area of the home can*



**create a health and fire hazard. The dryer exhaust system *MUST* be exhausted to the outside of the dwelling!**

**⚠️ WARNING** Do not allow combustible materials (for example: clothing, draperies/curtains, paper) to come in contact with the exhaust system. The dryer ***MUST NOT*** be exhausted into a chimney, a wall, a ceiling, or any concealed space of a building which can accumulate lint, resulting in a fire hazard.

**⚠️ WARNING** Do not exceed the length of duct pipe or number of elbows allowed in the ***“EXHAUST DUCT LENGTHS”*** chart. Lint can accumulate in the system, plugging the system and creating a fire hazard, as well as increasing drying times.

**⚠️ WARNING** Do not screen the exhaust ends of the vent system, nor use any screws or rivets to assemble the exhaust system. Lint can become caught in the screen, on the screws or rivets, clogging the exhaust system and creating a fire hazard as well as increasing drying times. Use an approved vent hood to terminate the duct outdoors, and seal all joints with duct tape. All male duct pipe fittings ***MUST*** be installed downstream with the flow of air.

**⚠️ WARNING** **Explosion hazard.** Do not install the laundry center where gasoline or other flammables are kept or stored. If the laundry center is installed in a garage, it must be a minimum of 18 inches (45.7 cm) above the floor. Failure to do so can result in death, explosion, fire or burns.

The exhaust system back pressure ***MUST*** not exceed 0.75 inches (1.89 cm) of water column measured with an inclined manometer at the point the exhaust connects to the dryer.

The exhaust system should be inspected and cleaned a minimum of every two years with normal usage. The more the dryer is used, the more often you should check the exhaust system and vent hood for proper operation.

The maximum length of the exhaust system depends upon the type of duct used, number of elbows and type of exhaust hood.

The maximum length for both rigid and flexible duct is shown in the chart below.

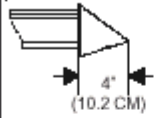
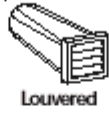
EXHAUST DUCT LENGTHS		
EXHAUST HOOD TYPE		
Number of 90° Turns		
	4" (10.2 CM)	2.5" (6.35 CM)
<b>MAXIMUM LENGTH OF 4-INCH (10.2 CM) DIAMETER RIGID METAL DUCT</b>		
0	56 ft. (17.07 m)	42 ft. (12.8 m)
1	46 ft. (14.02 m)	36 ft. (10.97 m)
2	34 ft. (10.36 m)	28 ft. (8.53 m)
3	32 ft. (9.75 m)	18 ft. (5.48 m)
<b>MAXIMUM LENGTH OF 4-INCH (10.2 CM) DIAMETER FLEXIBLE METAL DUCT</b>		
0	30 ft. (9.14 m)	22 ft. (6.7 m)
1	22 ft. (6.7 m)	14 ft. (4.27 m)
2	16 ft. (4.88 m)	10 ft. (3.05 m)
3	10 ft. (3.05 m)	5 ft. (1.5 m)

The laundry center may be exhausted four (4) ways with rear ***flush*** installation:

1. ***Straight back***
2. ***Down*** (8 inch [20.32 cm] length of 4 inch [10.16 cm] rigid duct and 1 elbow down)
3. ***Left*** (8 inch [20.32 cm] length of 4 inch [10.16 cm] rigid duct, 1 elbow down and 1 elbow left)
4. ***Right*** (8 inch [20.32 cm] length of 4 inch [10.16 cm] rigid duct, 1 elbow down and 1 elbow right)

To exhaust up, add an 11 inch (27.94 cm) length of standard 4 inch (10.16 cm) diameter duct and a 90° elbow. The unit will be positioned about 4½ inches (11.43 cm) away from the wall (flush to wall exhausting may be done by going below the dryer then sideways).

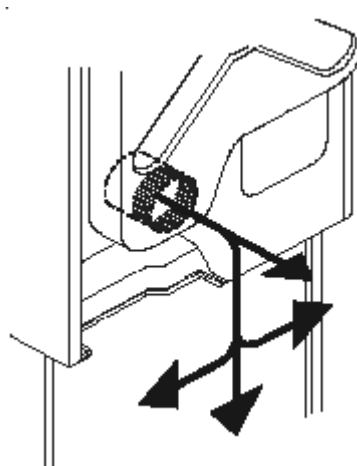



An exhaust hood positioned to line up with the dryer exhaust can be installed directly through the outside wall. To exhaust to the side or down, add an 8 inch (20.32 cm) length of standard 4 inch (10.16 cm) diameter duct and a 90° elbow.

### **GAS SUPPLY REQUIREMENTS**

1. Installation **MUST** conform with local codes, or in the absence of local codes, with the National Fuel Gas Code, ANSI Z223.1 (latest edition) or in Canada, the current AN/CGA B149.
2. The gas supply line should be of 1/2 inch (1.27 cm) pipe.
3. If codes allow, flexible metal tubing may be used to connect your dryer to the gas supply line. The tubing **MUST** be constructed of stainless steel or plastic-coated brass.
4. The gas supply line **MUST** have an individual shutoff valve.
5. A 1/8 inch (0.32 cm) N. P. T. plugged tapping, accessible for test gage connection, **MUST** be installed immediately upstream of the gas supply connection to the dryer.
6. The dryer and its individual shutoff valve **MUST** be disconnected from the gas supply piping system during any pressure testing of the gas supply piping system at test pressures equal to or less than 1/2 psig (3.45 kPa).
7. The dryer **MUST** be isolated from the gas supply piping system by closing its individual manual shutoff valve during any pressure testing of the gas supply piping system at test pressures equal to or less than 1/2 psig (3.45 kPa).

### **LOCATION OF YOUR LAUNDRY CENTER**

#### **DO NOT INSTALL YOUR LAUNDRY CENTER:**

1. In an area exposed to dripping water or outside weather conditions.
2. In an area where it will come in contact with curtains or drapes.
3. On carpet. Floor **MUST** be solid with a maximum slope of 1 inch (2.54 cm).
4. On a pedestal. Excessive vibration can occur

### **INSTALLATION IN RECESS OR CLOSET**

1. A laundry center installed in a bedroom, bathroom, recess or closet, **MUST** be exhausted outdoors.
2. No other fuel burning appliance shall be installed in the same closet as the **Gas** laundry center.
3. Your laundry center needs the space around it for proper ventilation.

#### **DO NOT INSTALL YOUR LAUNDRY CENTER IN A CLOSET WITH A SOLID DOOR.**

4. A minimum of 120 square inches (774.2 square cm) of opening, equally divided at the top and bottom of the door, is required. Air openings are required to be unobstructed when a door is installed. A louvered door with equivalent air openings for the full length of the door is acceptable.

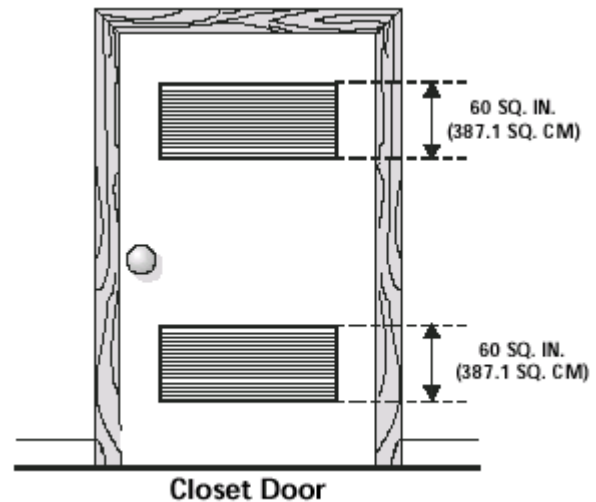

5. The following illustrations show minimum clearance dimensions and air openings for proper operation in a recess or closet installation.

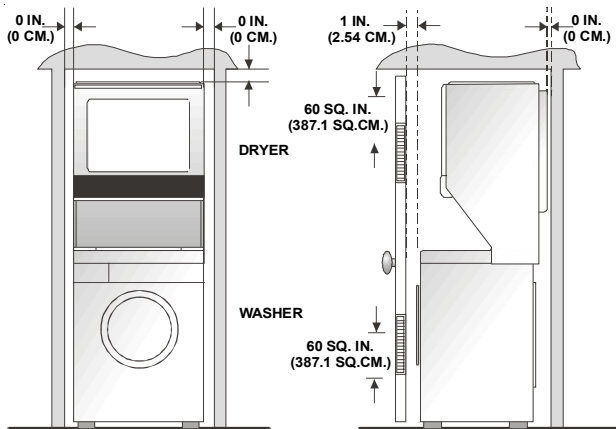

### MOBILE HOME INSTALLATION

1. Dryer **MUST** be exhausted outside (outdoors, not beneath the mobile home) using metal ducting that will not support combustion. Metal ducting must be 4 inches (10.16 cm) in diameter with no obstructions. Rigid metal duct is preferred.
2. If dryer is exhausted through the floor and area beneath the mobile home is enclosed, the exhaust system **MUST** terminate outside the enclosure with the termination securely fastened to the mobile home structure.
3. Refer to EXHAUST SYSTEM REQUIREMENTS for other important venting requirements.

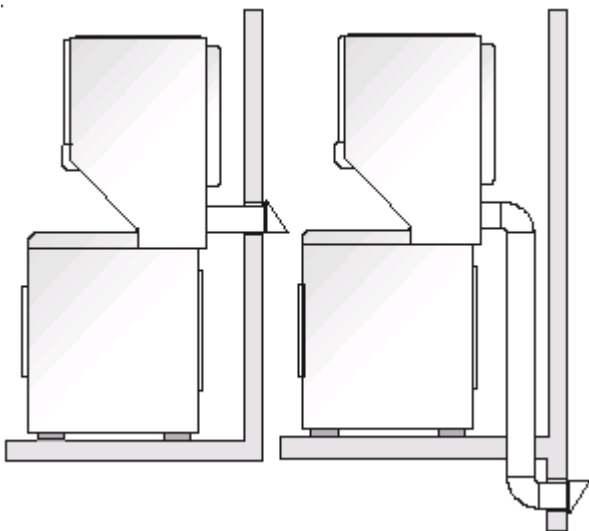

4. When installing a gas dryer into a mobile home, a provision must be made for outside make up air. This provision is to be not less than twice the area of the dryer exhaust outlet.

5. Installation **MUST** conform to current Manufactured Home Construction & Safety Standard (which is a Federal Regulation Title 24 CFR-Part 32-80) or when such standard is not applicable, with American National Standard for Mobile Homes. In Canada, the CSA Z240 is applicable.

**WARNING** The laundry center is designed under ANSI Z 21.5.1 for HOME USE HOME USE HOME USE HOME USE HOME USE only.

### UNPACKING

1. Using the four shipping carton corner posts (two on each side), carefully lay the laundry center on its left side and remove the foam shipping base.

**NOTE: Because of the weight of the appliance, two people may be required.**

2. Return laundry center to an upright position.
3. Remove the following from the back side of the washer:
  - 4 bolts,
  - 4 yellow plastic spacers,
  - 3 metal "P" clamps.
4. Remove the service panel from the front of the washer.
5. Remove the 4 nuts and 6 large washers that attach the 2 yellow shipping braces to the drum and the base. Lift up on the drum and remove the braces (a yellow ribbon surrounds the items to be removed).

## ROUGH-IN DIMENSION

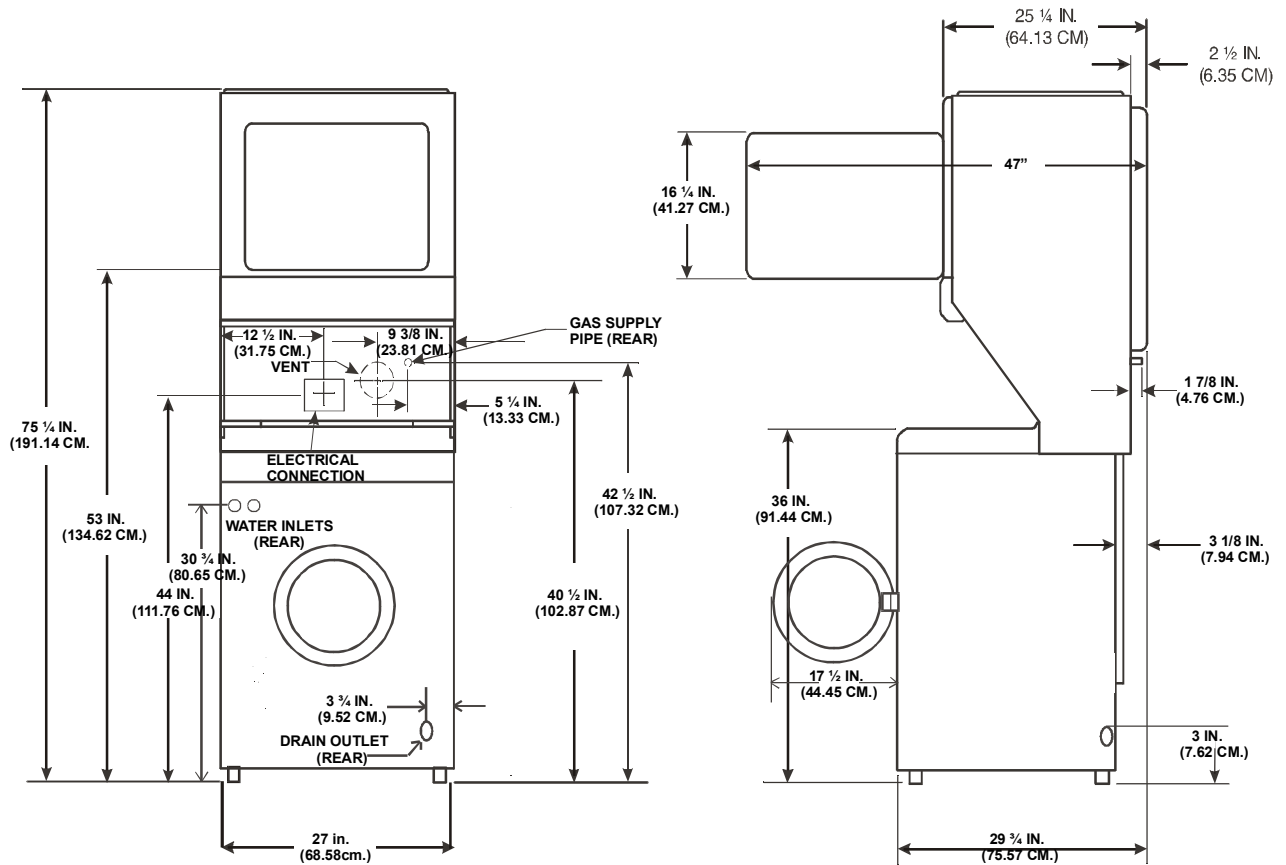

- Remove the large styrofoam block located under the drum. Lift up on the drum, tilt the base of the foam block inwards toward the rear of the washer until free, then pull it out.
  - Remove and discard the yellow ribbon and label from the front of the washer.
  - Replace the service panel and screws.
  - Carefully move the laundry center to within 4 feet (1.22m) of the final location to begin the installation.
- NOTE: If the laundry center is to be transported at a later date, the shipping support hardware must be reinstalled to prevent shipping damage.**

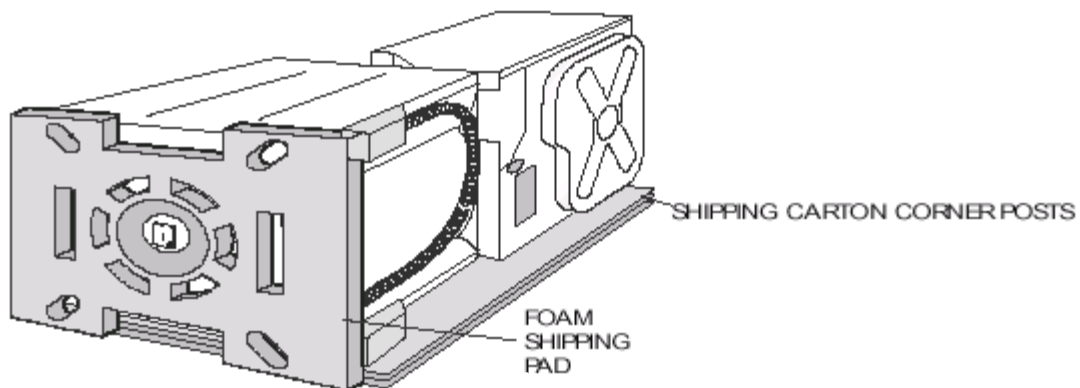

## ELECTRICAL INSTALLATION

### ALL ELECTRIC Laundry Centers

**⚠ WARNING** The following are specific requirements for proper and safe electrical installation of your laundry center. Failure to follow these instructions can create an electrical shock and/or a fire hazard.

**⚠ WARNING** This appliance **MUST** be properly grounded. Electrical shock can result if the laundry center is not properly grounded. Follow the instructions in this manual for proper grounding.

**⚠ WARNING** Do not use an extension cord with this laundry center. Some extension cords are not designed to withstand the amounts of electrical current this laundry center utilizes and can melt, creating electrical shock and/or fire hazard. Locate the laundry center within reach of the receptacle for the length power cord to be purchased, allowing some slack in the cord. Refer to the pre-installation requirements in this manual for the proper power cord to be purchased.

**⚠ WARNING** A U.L. approved strain relief must be installed onto power cord. If the strain relief is not attached, the cord can be pulled out of the laundry center and can be cut by any movement of the cord, resulting in electrical shock.

**⚠ WARNING** Do not use an aluminum wired receptacle with a copper Wired power cord and plug (or vice versa). A chemical reaction occurs between copper and aluminum and can cause electrical shorts. **The proper wiring and receptacle is a copper wired power cord with a copper wired receptacle OR aluminum wired power cord with an aluminum wired receptacle.**

**NOTE:** Laundry centers operating on a 208 volt power supply will have longer drying times than laundry centers operating on a 240 volt power supply.

## GROUNDING REQUIREMENTS

### Non-Canadian ELECTRIC Laundry Center

**⚠ DANGER** Improper connection of the equipment grounding conductor can result in a risk of electrical shock. Check with a licensed electrician if you are in doubt as to whether the appliance is properly grounded.

For a grounded, cord-connected laundry center:

1. The laundry center **MUST** be grounded. In the event of malfunction or breakdown, grounding will reduce the risk of electrical shock by a path of least resistance for electrical current.
2. If your laundry center is equipped with a power supply cord having an equipment-grounding conductor and a

grounding plug, the plug **MUST** be plugged into an appropriate, copperwired receptacle that is properly installed and grounded in accordance with all local codes and ordinances. If in doubt, call a licensed electrician.

For a permanently connected laundry center:

The laundry center **MUST** be connected to a grounded metal, permanent wiring system; or an equipment grounding conductor **MUST** be run with the circuit conductors and connected to the equipment-grounding terminal or lead on the appliance.

### Canadian ELECTRIC Laundry Center

**⚠ DANGER** Improper connection of the equipment grounding conductor can result in a risk of electrical shock. Check with a licensed electrician if you are in doubt as to whether the appliance is properly grounded.

For a grounded cord connected laundry center:

1. The laundry center **MUST** be grounded. In the event of malfunction or breakdown, grounding will reduce the risk of electrical shock by providing a path of least resistance for the electrical current.
2. Since your laundry center is equipped with a power supply cord having an equipment-grounding conductor and a grounding plug, the plug **MUST** be plugged into an appropriate outlet that is properly installed and grounded in accordance with all codes and ordinances. If in doubt, call a licensed

## ELECTRICAL CONNECTIONS FOR A 4-WIRE SYSTEM

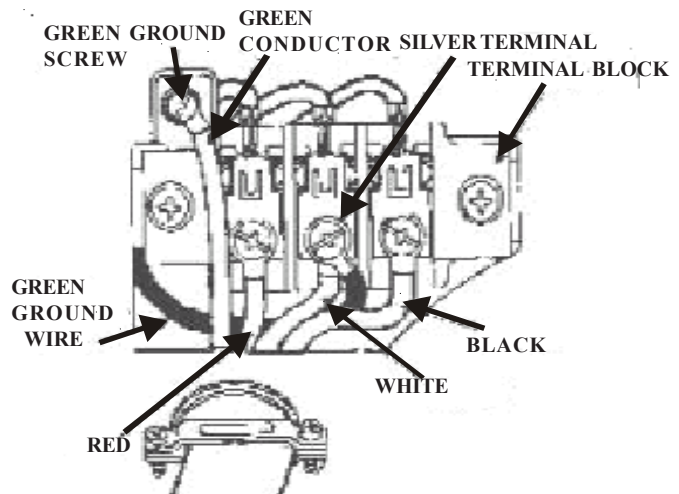

1. Remove the screw securing the terminal block access cover to the rear panel and remove cover.
2. Install a U.L. approved strain relief connector in the entry hole on the back panel.

3. Insert a NEMA 14-30 Type ST or SRDT, U.L. approved power cord through the strain relief.
4. Attach the green power cord ground wire to the cabinet with the green ground screw.
5. Attach the white (neutral) wire from the power cord to the silver-colored center terminal on the terminal block. Tighten the screw securely.
6. Attach the red and black wires from the power cord to the outer brass-colored terminals on the terminal block. Tighten both screws securely.
7. Tighten the screws securing the cord restraint firmly against the power cord.
8. Reinstall the terminal block access cover.

4. Attach the power cord neutral (central wire) conductor to the silver colored center terminal on the terminal block. Tighten the screw securely.

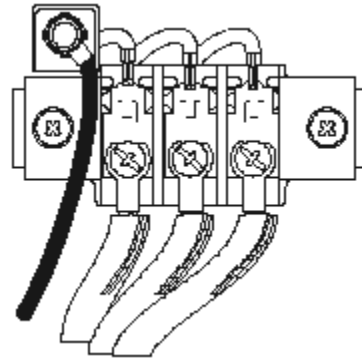

### ALL GAS Laundry Centers

1. The laundry center, when installed, **MUST** be electrically grounded in accordance with local codes, or in the absence of local codes, with the National Electrical Codes, ANSI/NFPA (latest edition) or in Canada, CSA C22.1 Canadian Electrical Code Part 1.
2. The laundry center is equipped with a three-prong (grounding) plug for your protection against shock hazard and should be plugged directly into a properly grounded three-prong receptacle. Do not cut or remove the grounding prong from the plug.

5. Attach the remaining two power cord outer conductors to the outer brass colored terminals on the terminal block. Tighten both screw securely.
6. Tighten the screws securing the cord restraint against the power cord.
7. Reinstall the terminal access cover.

### ELECTRICAL CONNECTIONS FOR A 3-WIRE SYSTEM

*NON-CANADIAN ELECTRIC Laundry Center*

1. Remove the screw securing the terminal block access cover to the rear panel and remove cover.
2. Install a U.L. approved strain relief connector in the entry hole on the back panel.
3. Insert a NEMA 10-30 Type SRDT, U.L. approved power cord through the strain relief.

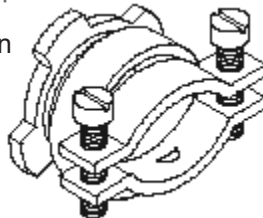

### ELECTRICAL CONNECTIONS FOR A 4-WIRE SYSTEM

*NON-CANADIAN ELECTRIC Laundry Center*

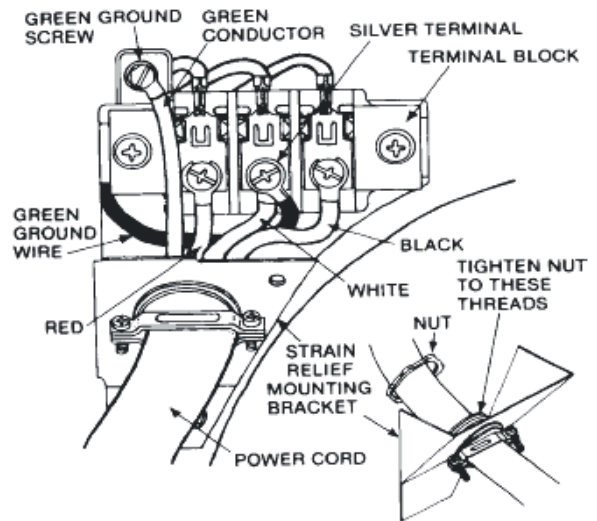

1. Remove the screw securing the terminal block access cover to the rear panel and remove cover.

2. Install a U.L. approved strain relief connector in the entry hole on the back panel.

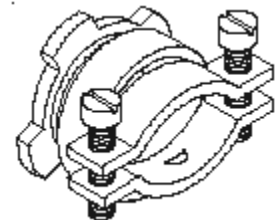

3. Remove the green neutral ground wire from the green ground screw located above the terminal block.
4. Insert a NEMA 14-30 Type ST or SRDT, U.L. approved power cord through the strain relief.
5. Attach the green power cord ground wire to the cabinet with the green ground screw.
6. Attach the white (neutral) wire from the power cord and the green ground wire from the appliance harness to the silver-colored center terminal on the terminal block. Tighten the screw securely.
7. Attach the red and black wires from the power cord to the outer brass-colored terminals on the terminal block. Tighten both screws securely.
8. Tighten the screws securing the cord restraint firmly against the power cord.
9. Reinstall the terminal block access cover.

## INSTALLATION

1. Run some water from the hot and cold faucets to flush the water lines and remove particles that might clog up the water valve screens.
2. Check inlet hoses to ensure the rubber washers are installed in each end.
3. Carefully connect the inlet hoses to the water valve (on the left side of the washer cabinet), tighten by hand, then tighten another 2/3 turn with pliers.



**CAUTION DO NOT CROSS THREAD OR OVERTIGHTEN THESE CONNECTIONS.**

4. Determine which water faucet is the **HOT** water faucet and carefully connect the bottom inlet hose to the **HOT** water faucet, tighten by hand, then tighten another 2/3 turn with pliers. Carefully connect the top inlet hose to the **COLD** water faucet, tighten by hand, then tighten another 2/3 turn with pliers.



**CAUTION DO NOT CROSS THREAD OR OVERTIGHTEN THESE CONNECTIONS.**

Turn the water on and check for leaks at both connections.

5. Carefully move the laundry center to its final location. Rollers on the rear of the washer base allow for easy movement in closet or alcove installations. Gently push back on the washer cabinet. **NOTE:** Gently

pushing the dryer cabinet may lift the front of the washer over 1/8" which will engage the rear legs to the floor.

6. With the washer in its final position, place a level on top of the washer, no rocking of the washer should exist. Adjust the front leveling legs up or down to ensure the washer is resting solid. Rear leg adjustment is accessible through the front service panel. Turn the lock nuts on each leg up towards the base of the washer and snug with a wrench.

**NOTE:** Leg extension should not be over one (1) inch to prevent excessive vibration.

## 7. GAS CONNECTION (Gas laundry centers only)

- a. Remove the shipping cap from gas pipe at the rear of the dryer.

**NOTE: DO NOT** connect the laundry center to L.P. gas service without converting the gas valve. An L.P. conversion kit must be installed by a qualified gas technician.

- b. Connect a 1/2 inch (1.27 cm) I.D. semi-rigid or approved pipe from the gas supply line to the 3/8 inch (0.96 cm) pipe located on the back of the dryer. Use a 1/2 inch (1.27 cm) to 3/8 inch (0.96 cm) reducer for the connection. Apply an approved thread sealer that is resistant to the corrosive action of liquefied gases on all pipe connections.
- c. Open the shutoff valve in the gas supply line.
- d. Test all connections by brushing on a soapy water solution. **NEVER TEST FOR GAS LEAKS WITH AN OPEN FLAME.**

8. Form a "U" shape on the end of the drain hose with the hose pointed toward the drain. Place the formed end in a laundry tub or a standpipe and secure with a cable tie provided in the enclosure package. An air gap must be around the drain hose. **WATER WILL SIPHON FROM THE WASHER IF THE ABOVE INSTRUCTIONS ARE NOT FOLLOWED.**



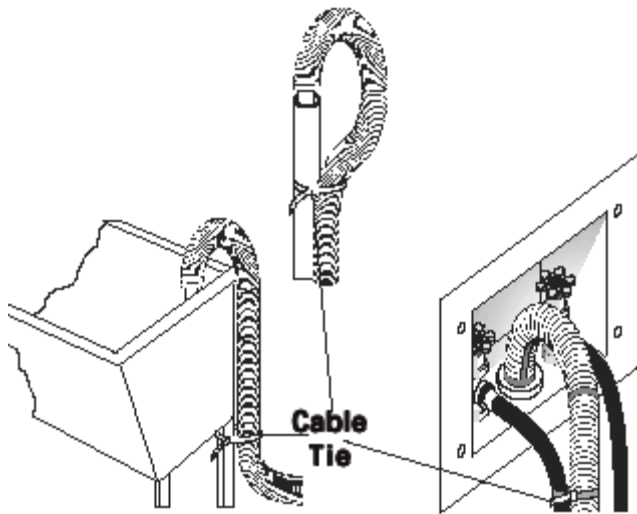

9. Remove the two (2) screws securing the dryer front access panel to the dryer cabinet. Lift the panel until the tabs can be disengaged from the cabinet. Remove the panel and set aside.

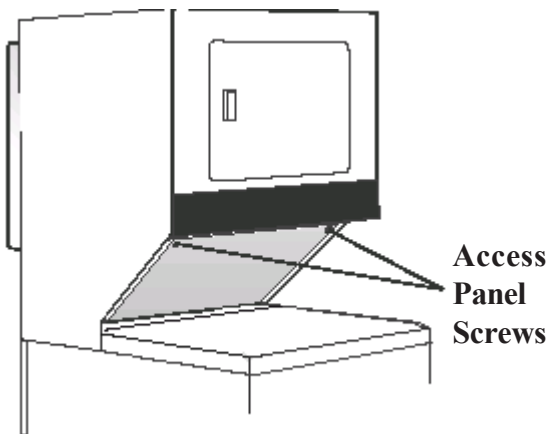

10. Connect the exhaust duct to outside duct work. Use duct tape to seal all joints.
11. Plug the power cord into a grounded outlet.  
**NOTE:** Check to ensure the power is off at a circuit breaker/fuse box before plugging the power cord into an outlet.
12. Turn on the power at a circuit breaker/fuse box.

**CAUTION** Before operating the dryer, make sure the dryer area is clear and free from combustible materials, gasoline, and other flammable vapors. Also see that nothing (such as boxes, clothing, etc.) obstructs the flow of combustion and ventilation air.

13. Reinstall the dryer front access panel.

14. Run the washer and dryer through a cycle. Check for proper operation.

**Note:** On gas dryers, before the burner will light, it is necessary for the gas line to be bled of air. If the burner does not light within 45 seconds the first time the dryer is turned on, the safety switch will shut the burner off. If this happens, turn the timer to "OFF" and wait 5 minutes before making another attempt to light.

15. If your laundry center does not operate, please review the "Avoid Service Checklist" located in your Owner's Guide before calling for service.

16. Place these instructions in a location near the laundry center for future reference.

**NOTE:** A wiring diagram is located behind the dryer front access panel.

## REPLACEMENT PARTS

If replacement parts are needed for your laundry center, contact the source where you purchased your laundry center.

**WARNING** Destroy the carton, plastic bags, and metal band after the laundry center is unpacked. Children might use them for play. Cartons covered with rugs, bedspreads, or plastic sheets can become airtight chambers causing suffocation. Place all materials in a garbage container or make materials inaccessible to children.

**CAUTION** Label all wires prior to disconnection when servicing controls. Wiring errors can cause improper and dangerous operation. Verify proper operation after servicing.

**WARNING** The instructions in this manual and all other literature included with this laundry center are not meant to cover every possible condition and situation that may occur. Good safe practice and caution **MUST** be applied when installing, operating and maintaining any appliance.

Maximum benefits and enjoyment are achieved when all the Safety and Operating instructions are understood and practiced as a routine with your laundry tasks.

## Section B - Dryer Operating Instruction

### Tumble Action Laundry Center

#### Gas & Electric

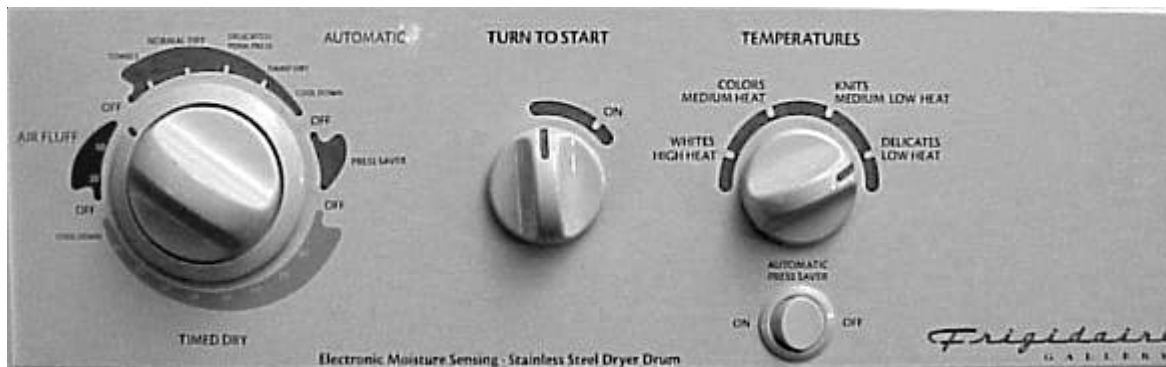

### Before Operating Your Dryer

**Read your Owner's Guide.** It has important safety and warranty information. It also has many suggestions for best drying results.

**WARNING** To reduce the risk of fire, electric shock, or injury to persons, read the IMPORTANT SAFETY INSTRUCTIONS in your owner's guide before operating this appliance.

### Operating Steps

**Read Drying Procedures in your Owner's Guide.** It explains these operating steps in detail.

1. **Prepare items for drying.**
2. **Check that lint screen is clean and in place.**
3. **Load the dryer.** If desired, add a dryer fabric softener sheet.
4. **Close the dryer door.**
5. **Set Drying Temperatures control.**
6. **Turn cycle selector clockwise to desired setting.**
7. **Start dryer.** Turn the Turn to Start control clockwise to ON. Hold for 1-2 seconds and release.
8. **A signal will sound when the cycle ends.**

9. **Remove items immediately and hang or fold.**

10. **Clean lint screen after every load.**

### Temperature Selection

**Always follow directions on fabric care labels.**

**WARNING** To avoid fire hazard, do not use heat to dry items containing feathers or down, foam rubber, plastics, or similarly textured, rubber-like materials. Use Air Fluff cycle only.

The **REGULAR/WHITES-HIGH HEAT, PERM PRESS/COLORS-MEDIUM HEAT**, and **KNITS-MEDIUM LOW HEAT and DELICATES-LOW HEAT** temperature settings may be used with any cycle setting.

### Cycle Selection

Turn cycle selector clockwise to desired cycle and setting.

Each cycle ends with a cool down period. The heat automatically turns off and the load continues to tumble for 5-10 minutes. This reduces wrinkling and makes items easier to handle during unloading. Drying time varies depending on size and dampness of load, weight and fabric type. Room temperature and humidity, type of installation and electrical voltage or gas pressure can also affect drying time.

### Automatic Dry Cycle

- **TOWELS** - This setting is best for towel loads.



Select the REGULAR/WHITES—HIGH HEAT temperature setting.

- **NORMAL** - This setting is best for cotton items. Select the REGULAR/WHITES—HIGH HEAT temperature setting.
- **DELICATES/PERM PRESS** - This setting is best for delicate, knit, or perm press items. Select the PERM PRESS/COLORS—MEDIUM HEAT temperature setting for permanent press items, the KNITS—MEDIUM-LOW temperature setting for most knit items, or the DELICATES—LOW HEAT temperature setting for delicate items.
- Occasionally a load may seem too damp or overdried at the end of the cycle. To increase drying time for similar loads in the future, set the cycle selector on the indicator line to the left of the TOWELS, NORMAL, or DELICATES/PERM PRESS setting. For loads requiring less drying time, set the cycle selector on the indicator line to the right.
- **DAMP DRY** - This setting is best for items you wish to partially dry before hanging or ironing. Select the temperature setting most suitable for the load.
- **Press Saver** - **If the dried load cannot be removed promptly at the end of the cycle, the cycle selector will automatically automatically automatically advance to the Press Saver setting if the Press Saver Press Saver Press Saver Press Saver Press Saver Press Saver option is turned ON . Unheated tumbling continues for up to 24 minutes to help reduce wrinkling. The timer will not will not will not will not will not automatically advance into the Press Saver setting if the Press Saver Press Saver Press Saver Press Saver Press Saver option is turned OFF.**

**Note: Press Saver Note: Press Saver Note: Press Saver Note: Press Saver Note: Press Saver Note: Press Saver can be used independently for up to 15 minutes of unheated tumbling to help remove wrinkles from items that are already dry. Turn selector knob to Press Saver and start dryer. It is not necessary to set Temperatures or Press Saver option controls.**

### **Air Fluff Cycle**

This cycle provides up to 20 minutes of tumbling without heat. Use AIR FLUFF to dry items containing feathers or down, foam rubber, plastics, or similarly textured,

rubber-like materials, to freshen clothing, pillows or blankets, or to dust draperies.

### **Timed Dry Cycle**

This cycle provides approximately 80 minutes of drying time at the temperature selection of your choice.

### **Energy Saving Tips**

- Keep the lint screen clean and exhaust the dryer correctly.
- Sort laundry properly and select proper temperature and cycle settings. Choose an automatic dry cycle whenever possible for accurate drying time.
- Dry only full loads. Single items and small loads usually take longer to dry.
- Avoid overloading, adding wet items to a partially dry load, and overdrying.
- Dry one load after another to take advantage of a warm dryer.
- Opening the door needlessly causes warm air to escape, which prolongs drying time.
- If possible, use the dryer on low humidity days.
- Install the dryer in an area where the room temperature is at least 45°F (7°C).

## Section C - Washer Operating Instruction Tumble Action Laundry Center



### Before Operating Your Washer

**Read your washer Use and Care Guide.** It has important safety and warranty information. It also has many suggestions for best washing results.

**WARNING** To reduce the risk of fire, electric shock, or injury to persons, read the IMPORTANT SAFETY INSTRUCTIONS in your washer Use and Care Guide before operating this appliance.

### Operating Steps

Read and follow **Washing Procedures** in your Use and Care Guide. It provides detailed information for preparing the wash load and choosing control settings to ensure best washing results.

1. **Sort laundry into loads that can be washed together.**
2. **Prepare items for washing.**
3. **Pretreat stains and heavy soil.**
4. **Add laundry load to the wash drum.**
5. **Open the dispenser drawer and add the measured amount of detergent to the detergent compartment.** If desired, add liquid bleach and fabric softener to the appropriate compartments. Slowly close dispenser drawer. The washer will not operate with the drawer open.
6. **Set Temperature switch according to fabric type and soil level of each load.**
7. **If desired, select Extra Rinse in Whites/Regular, Colors/Perm Press, or Delicates cycle.**

8. **Select Final Spin Speed as desired.**
9. **Push in the cycle selector knob and turn it clockwise to the desired wash cycle and setting.**
10. **Start the washer by closing the door and pulling out the cycle selector knob.** The washer will **not** operate with the door open. As a safety measure, the door will automatically lock during the entire wash cycle. When the door is closed, the **Door Lock Indicator** lights up when the washer starts, and turns off at the end of the cycle.
  - To stop the washer, push in the cycle selector knob.
  - To change a cycle, push in the cycle selector knob and turn it clockwise to the desired setting.
  - Pull out the knob to restart the washer.
11. **Remove items when cycle ends.** A signal will sound at the end of the cycle.

**Note:** From time to time you may see water in the bleach and fabric softener compartments. This is a result of the siphoning action and is part of the normal operation of the washer.

### Cycle Selection

For best results, follow the fabric care label directions on items to be washed.

#### Whites/Regular Cycle

Up to 18 minutes of reversing tumble action for most fabrics. Three rinses, three spins, a pause and a brief tumble complete the cycle. Select **NORMAL** or **FAST** Final Spin as desired.

- **Heavy Wash** provides up to 18 minutes of reversing tumble action for heavily soiled fabrics.
- **Wash** provides up to 13 minutes of reversing tumble action for normally soiled fabrics.
- **Light Wash** provides up to 6 minutes of reversing tumble action for lightly soiled fabrics.

### Short Wash Cycle

Saves time and water. Up to 6 minutes of reversing tumble action for very lightly soiled fabrics. Two rinses, two spins, a pause and a brief tumble complete the cycle. Extra Rinse is not an option with this water conserving cycle. Select **NORMAL** or **FAST** Final Spin as desired for this cycle.

### Colors/Perm Press Cycle

Up to 13 minutes of reversing tumble action for cottons and blends with a no-iron finish. Three rinses, three spins, a pause and a brief tumble complete the cycle. Select **NORMAL** or **FAST** Final Spin as desired for this cycle.

- **Wash** provides up to 13 minutes of reversing tumble action for heavily soiled fabrics.
- **Extra Care** provides up to 6 minutes of reversing tumble action for lightly soiled fabrics.

### Knits and Delicates Cycle

Up to 10 minutes of gentle tumble action for the gentle care of knit, delicate and hand washable items. Two rinses and two spins complete the cycle. Select **NORMAL** or **FAST** Final Spin as desired for this cycle.

### Controls

Always follow instructions on fabric care labels.

**Note:** There is no need to select a water level because the washer automatically adjusts the water level to the type and size of wash load.

**TEMPERATURES** - This determines water temperatures for washing and rinsing. For example, the Warm/Cold setting provides a warm water wash and a cold water final rinse.

**Note:** Detergents are not as effective at wash water temperatures below 65°F (18.3°C).

The following chart suggests wash/rinse temperatures for basic fabric types.

<b>Fabric Type</b>	<b>Wash/Rinse Temperature</b>
Heavily soiled white/colorfast cotton, perm press	Hot/Cold
Normally soiled white/colorfast cotton, perm press	Warm/Cold
Lightly soiled/noncolorfast fabrics, knits, delicates, hand washables	Cold/Cold
Washable woolens	Warm/Cold

**CYCLE SIGNAL** - A signal will sound at the end of the cycle.

When the door is closed, the **Door Lock Indicator** lights up when the cycle selector knob is pulled out, and turns off at the end of the cycle.

**EXTRA RINSE** - Use Extra Rinse when additional rinsing is desired to remove excess dirt and detergent from heavily soiled loads.

- Select **Extra Rinse On** to automatically include an extra rinse in Whites/Regular, Colors/Perm Press, or Delicates cycle.
- Select **Extra Rinse Off** to conserve water when an extra rinse is not desired.

**FINAL SPIN** - There are two final spin speed options available for each cycle. Note: The speeds will vary from cycle to cycle. For example, **Regular Fast** spin speed is much faster than **Delicate Fast** spin speed.

- **NORMAL** is recommended for most loads.
- **FAST** provides a faster spin speed to increase water extraction and decrease drying time.

## Section D - Owner Guide Tumble Action Laundry Center

For your safety, the information in this manual must be followed to minimize the risk of fire or explosion or to prevent property damage, personal injury or loss of life.

- Do not store or use gasoline or other flammable vapors and liquids in the vicinity of this or any other appliance.
- **WHAT TO DO IF YOU SMELL GAS:**
  - Do not try to light any appliance.
  - Do not touch any electrical switch; do not use any phone in your building.
  - Clear the room, building or area of all occupants.
  - Immediately call your gas supplier from a neighbor's phone. Follow the gas supplier's instructions.
  - If you cannot reach your gas supplier, call the fire department.

Installation and service must be performed by a qualified installer, service agency or the gas supplier.

### Product Registration

Thank you for choosing this laundry center. This owner's guide will explain proper operation and care.

### Record Your Model and Serial Numbers

Record below the model and serial numbers found on the laundry center serial plate located on the inside of the dryer door. Keep these numbers for future reference.

Model Number \_\_\_\_\_  
Serial Number \_\_\_\_\_  
Date of Purchase \_\_\_\_\_

### Register Your Product

The self-addressed **PRODUCT REGISTRATION CARD** should be filled in completely, signed and returned.

This Owner's Guide provides general operating instructions for your laundry center. It also contains information about features for several other models. Your laundry center may not have every feature included here. Use the laundry center only as instructed in this Owner's Guide and the **Operating Instructions** included with your laundry center.

©2000 White Consolidated Industries, Inc. All rights reserved.

## Important Safety Instructions

Read all instructions before using this laundry center.

 **WARNING** To reduce the risk of fire, electrical shock, or injury to persons when using this laundry center, comply with the basic warnings listed below.

 Failure to comply with these warnings could result in serious personal injuries.

### Prevent Fire

 **WARNING** Do not wash or dry items that have been previously cleaned in, soaked in, or spotted with gasoline, cleaning solvents, kerosene, waxes, etc. Do not store these items on or near the dryer. These substances give off vapors that could ignite or explode.

 **WARNING** Do not put oily or greasy rags or clothing on top of the laundry center. These substances give off vapors that could ignite the materials.

 **WARNING** Do not add gasoline, cleaning solvents, or other flammable or explosive substances to the wash water. These substances give off vapors that could ignite or explode.

 **WARNING** Under certain conditions, hydrogen gas may be produced in a hot water system that has not been used for 2 weeks or more. **HYDROGEN GAS IS EXPLOSIVE.** If the hot water system has not been used for such a period, before using the washer, turn on all hot water faucets and let the water flow from each for several minutes. This will release any accumulated hydrogen gas. Hydrogen gas is flammable; do not smoke or use an open flame during this time.

 **WARNING** To prevent fire, do not use heat to dry items containing plastic, foam rubber or similarly textured rubber-like materials, or items containing feathers or down. Use Air Fluff (No Heat) only.

 **WARNING** Clean the dryer lint screen before or after each load. The interior of the dryer, lint screen housing and exhaust duct should be cleaned approximately every 18 months by qualified service personnel. An excessive amount of lint build-up in these areas could re-

sult in inefficient drying and possible fire. See **Care and Cleaning**.

**WARNING** Do not operate the dryer if the lint screen is blocked, damaged or missing. Fire hazard, overheating and damage to fabrics can occur. If your dryer has a drying rack, always replace the lint screen when finished using the drying rack.

This Owner's Guide provides general operating instructions for your laundry center. It also contains information about features for several other models. Your laundry center may not have every feature included.

Use the laundry center only as instructed in this Owner's Guide.

**WARNING** Avoid fire hazard or electrical shock.

Do not use an adaptor plug or extension cord or remove grounding prong from electrical power cord. Failure to follow this warning can cause serious injury, fire or death.

#### **GAS LAUNDRY CENTERS:**

Grounding type wall receptacle

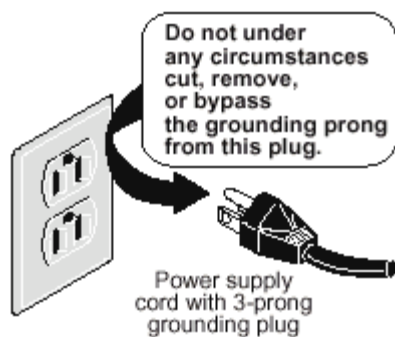

**CORRECT**  
Use this way **ONLY**

#### **FOR YOUR SAFETY**

Do not store or use gasoline or other flammable vapors or liquids in the vicinity of this or any other appliance.

**Note:** The instructions appearing in this Owner's Guide are not meant to cover every possible condition and situation that may occur. Common sense and caution must be practiced when installing, operating and maintaining any appliance.

**WARNING** Keep area around the exhaust opening and surrounding areas free from the accumulation of lint, dust and dirt.

**WARNING** Do not obstruct the flow of ventilating air. Do not stack or place laundry or throw rugs against the front or back of the laundry center.

**WARNING** Do not spray any type of aerosol into, on or near laundry center at anytime.

**WARNING** Do not use fabric softeners or products to eliminate static unless recommended by the manufacturer of the fabric softener or product.

**WARNING** Do not place items exposed to cooking oils in your dryer. Items contaminated with cooking oils may contribute to a chemical reaction that could cause a load to catch fire.

Failure to comply with these warnings could result in fire, explosion, serious bodily injury and/or damage to the rubber or plastic parts of the laundry center.

#### **Protect Children**

**WARNING** Do not allow children to play on or in the laundry center. Close supervision of children is necessary when the laundry center is used near children. As children grow, teach them the proper, safe use of all appliances.

**WARNING** Destroy the carton, plastic bag and other packing materials after the laundry center is unpacked. Children might use them for play. Cartons covered with rugs, bedspreads or plastic sheets can become airtight chambers.

**WARNING** Keep laundry products out of children's reach. To prevent personal injury, observe all warnings on product labels.

**WARNING** Before the laundry center is removed from service or discarded, remove the washer lid and dryer door to prevent accidental entrapment.

Failure to comply with these warnings could result in serious personal injuries.

#### **Prevent Injury**

**WARNING** To prevent shock hazard and assure



stability during operation, the laundry center must be installed and electrically grounded by a qualified service person in accordance with local codes. Installation instructions are packed in the laundry center for the installer's reference. Refer to INSTALLATION INSTRUCTIONS for detailed grounding procedures. If the laundry center is moved to a new location, have it checked and reinstalled by a qualified service person.

**⚠ WARNING** To prevent personal injury or damage to the laundry center, the electrical power cord of a gas laundry center must be plugged into a properly grounded system. **Never ground the laundry center to a gas pipe. Do not use an extension cord or an adaptor plug.**

**⚠ WARNING** Do not use or mix liquid chlorine bleach with other household chemicals such as toilet cleaners, rust removers, acid or products containing ammonia. These mixtures can produce dangerous fumes which can cause serious injury or death.



**⚠ WARNING** Follow package directions when using laundry products. Incorrect usage can produce poisonous gas—resulting in serious injury or death.

- **Do not** combine laundry products for use in 1 load unless specified on **the label**.
- **Do not Do not Do not Do not Do not mix chlorine bleach with ammonia or acids such as vinegar.**

**⚠ WARNING** To prevent serious personal injury and damage to the laundrycenter:

- **All repairs and servicing must be performed by an authorized servicer** unless specifically recommended in this Owner's Guide. Use only authorized factory parts.
- **Do not** tamper with controls.
- **Do not** install or store the laundry center where it will be exposed to the weather.

**⚠ WARNING** **ALWAYS disconnect** the laundry center from the electrical supply before attempting any service or cleaning. Failure to do so can result in electrical shock or injury.

**⚠ WARNING** Do not use any type of spray cleanser when cleaning dryer interior. Hazardous fumes or electrical shock could occur.

**⚠ WARNING** To prevent injury, do not reach into the washer while parts are moving. Before loading, unloading or adding items, push in the cycle selector knob and allow the tub to coast to a complete stop before reaching inside.

**⚠ WARNING** To prevent injury, do not reach into the dryer if the drum is moving. Wait until the dryer has stopped completely before reaching into the drum.

**⚠** A thermal limiter switch automatically turns off the dryer motor in the unlikely event of an overheated situation (electric dryers only). A service technician must replace the thermal limiter switch after correcting the fault.

**⚠** The washer is equipped with an electrical overload protector. The motor will stop if it becomes overheated. The washer will automatically restart after a cool down period of up to 30 minutes, if the washer has not been manually turned off during this time.

**⚠** Failure to comply with these warnings could result in serious personal injuries.

### Washing Procedures

- Follow the guidelines below for preparing the wash load.
- Read the **Washer Operating Instructions** for operating your specific model.

- **Always read and follow fabric care and laundry product labels.**

**WARNING** To reduce the risk of fire, electrical shock, or injury to persons, read **Important Safety Instructions**, before operating this washer.

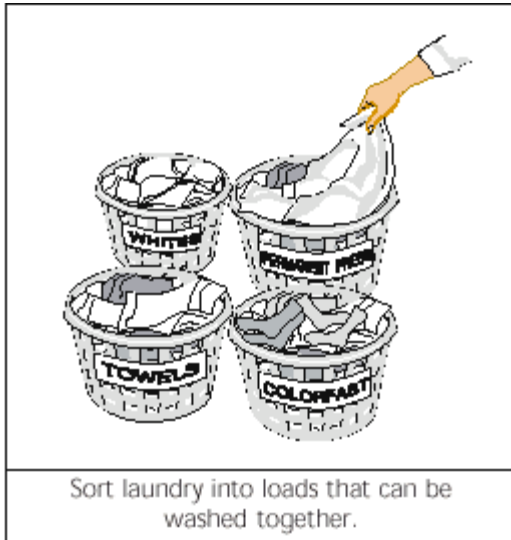

**1. Sort laundry into loads that can be washed together.**

Sort items by recommended water temperatures, wash time, and agitate/spin speeds.

- Separate white, light, and colorfast items from dark and noncolorfast items.
- Separate items which shed lint from items which attract lint. Permanent press, synthetic, knit and corduroy items will pick up lint from towels, rugs and chenille bedspreads.
- Separate heavily soiled items from lightly soiled items.
- Separate lacy, sheer and loosely knit items from sturdy items.

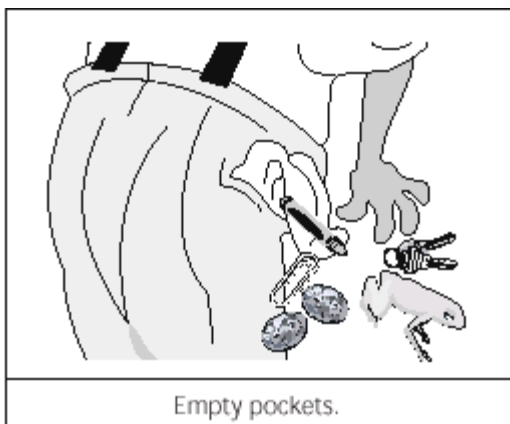

**2. Prepare items for washing.**

- Empty pockets.
- Brush off lint and dirt. Shake out rugs and beach towels.
- Close zippers, fasten hooks, tie strings and sashes, and remove nonwashable trims and ornaments.
- Remove pins, decorative buttons, belt buckles, and other objects which could be damaged. This also helps protect other items in the wash load.
- Mend rips and tears to prevent further damage during washing.

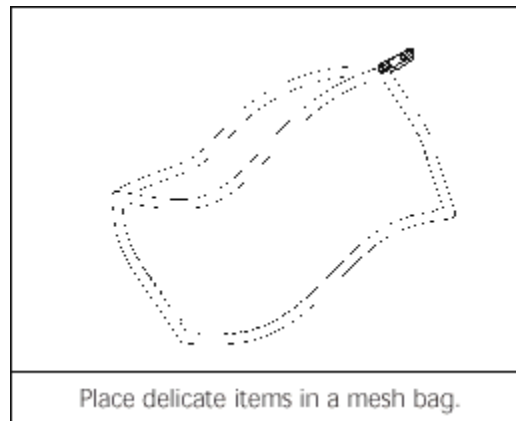

- Place delicate items such as bras and hosiery in a mesh bag to prevent tangling during the wash cycle.
- Turn knit items inside out to prevent pilling.

**3. Pretreat stains and heavy soil.**  
See **Stain Removal**, for details.



**4. Add laundry load to washer.**

- Combine large and small items in a load.

**Note:** From time to time you may see water in the bleach and fabric softener compartments. This is a result of the siphoning action and is part of the normal operation of the washer.

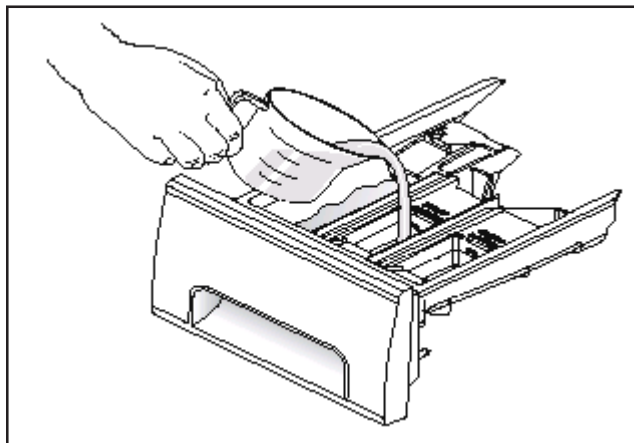

- If desired, measure out the recommended amount of liquid chlorine bleach (not to exceed 1/3 cup (80 mL) and pour it into the center compartment labeled “Liquid Bleach” and marked with this symbol. 
- Do not exceed the maximum fill line. Overfilling can cause early dispensing of the bleach which could result in damaged clothes.
- Do not pour undiluted liquid chlorine bleach directly onto the load or into the drum. Fabric damage can occur.
- **Do not use powdered bleach in the dispenser.**

#### D. FABRIC SOFTENER

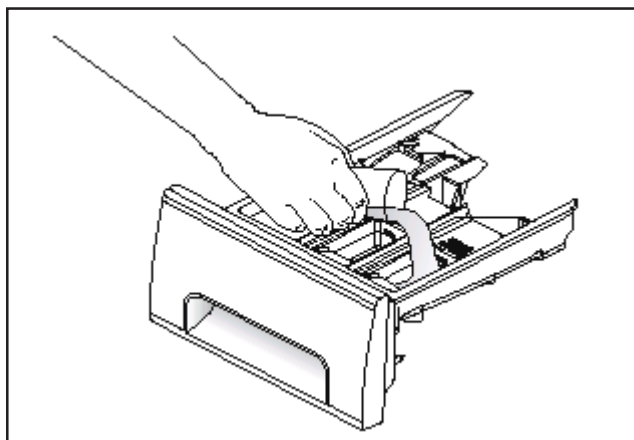

- If desired, pour the recommended amount of fabric softener into the compartment labeled “Fabric Softener” and marked with this symbol .



- Dilute concentrated softeners with warm water to the Fill Line.
- Do not exceed the maximum fill line. Overfilling can cause early dispensing of the fabric softener which could result in stained clothes.
- **Do not pour fabric softener directly on the wash load.**
- Use of a fabric softener dispensing ball is not recommended in tumble action washers.

#### 6. Set cycle selector knob and washer controls according to type, size, and soil level of each load.

(See **Operating Instructions** card for your specific model controls.)

#### 7. Start the washer.

Close the washer door and pull out the cycle selector knob. For your safety, the door will automatically lock during the entire wash cycle. The Door Lock indicator light will remain lit until the cycle ends.

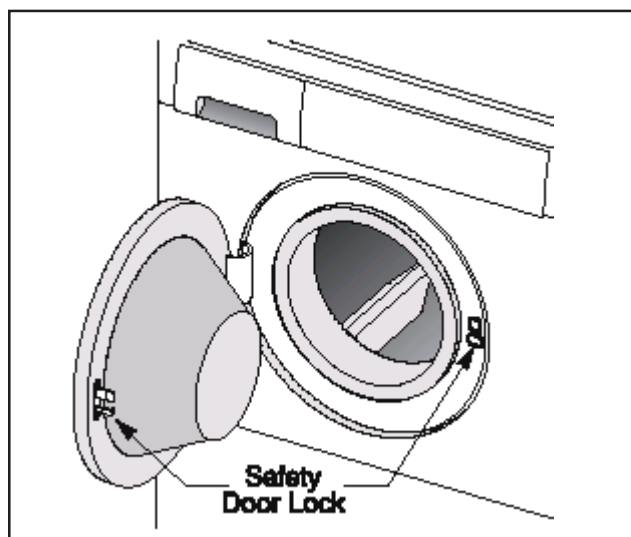

- Washer will fill and tumble.
- To stop the washer, push in the cycle selector knob.
- To open the door during tumbling, push in the cycle selector knob. Wait for the water to run off of the door.
- To change a cycle, push in the cycle selector knob and turn it **clockwise** to the desired setting. Pull out the knob to restart the washer.



**Load large items first. Large items should not be more than half the total wash load.**

- **Washing a single item such as a sweater, bath towel or jeans, is not recommended.** As the machine tumbles the load prior to final spin, it may sense an out-of-balance load. If an out-of-balance load is sensed, the washer will stop briefly and tumble for a short time to try to balance the load. This stop-tumble action may occur several times before the end of the cycle. If the load can not be evenly balanced, items may feel wet at the end of the cycle. Adding 1 or 2 similar items will help balance the load.
- If a load becomes tangled and out-of-balance, it may be necessary to rearrange the load by hand. Stop the washer by pushing in the cycle selector knob and open the door. Remove the load, untangle the items and return the load to the tub. Close the door and restart washer.
- **A single bulky item**, such as a bedspread, comforter or sleeping bag, can be laundered without adding extra items to the load.
- The washer can be fully loaded, but the items should not be tightly packed. The door should close easily.

**5. Add detergent, bleach and fabric softener to automatic dispenser following these steps:**

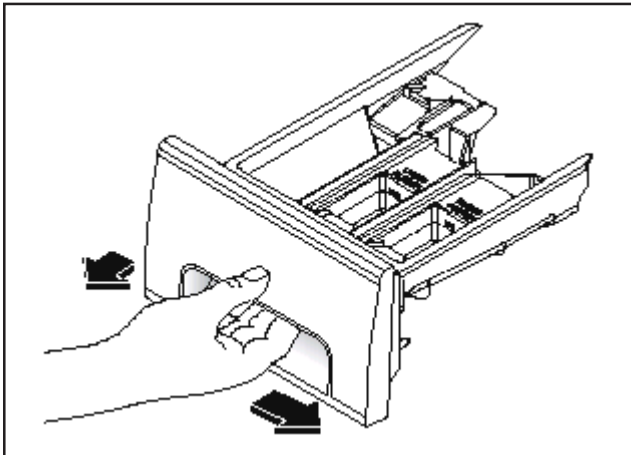

**A. OPENING AND CLOSING THE DISPENSER DRAWER**

- Slowly open the dispenser drawer by first sliding the safety latch to the right, then pulling the drawer out until it stops.
- After adding laundry products, slowly close the dispenser drawer. Closing the drawer too quickly

could result in early dispensing of the bleach and fabric softener.

**B. DETERGENT**

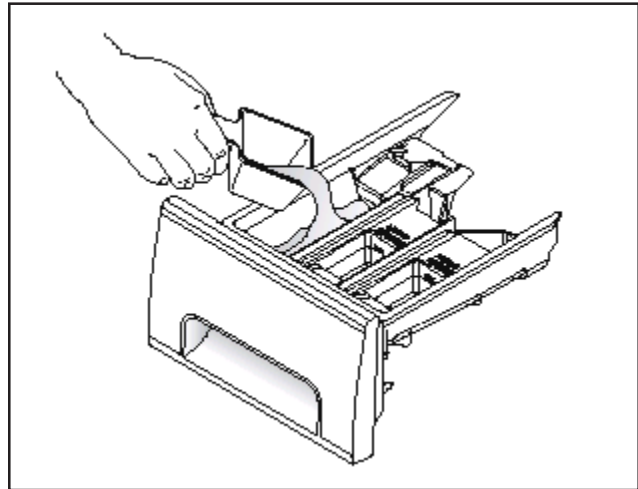

- Laundry products used with powder or liquid detergent, such as color-safe bleach, water conditioner, detergent booster, and enzyme products should be added to the empty tub before loading.
- Add measured detergent to the detergent compartment of the dispenser drawer.
- Detergent is flushed from the dispenser at the beginning of the cycle. Either powdered or liquid detergent can be used. Note: Liquid detergent will drain into the washer drum as it is added.
- High efficiency (HE), low sudsing detergent is recommended for this washer. Use the manufacturer's recommended amount.
- If low sudsing detergent is not available, a reduced amount of regular detergent may be used. Be cause reducing the amount of detergent may reduce cleaning, it is important to pretreat stains, sort carefully by color and soil level, and avoid overloading.
- Detergent usage may need to be adjusted for water temperature, water hardness, size and soil level of the load.
- For best results, avoid oversudsing.

**C. LIQUID BLEACH LIQUID BLEACH LIQUID BLEACH LIQUID BLEACH LIQUID BLEACH**

- To open the door during a spin cycle, push in the cycle selector knob. The Door Lock indicator light will turn off. Wait 1-2 minutes for the lock to release. The door can then be opened. Do not force open the locked door.

### 8. Remove items when the cycle is completed.

Place washed items in automatic dryer, line dry, or dry flat as directed by fabric care label. Excess wrinkling, color transfer or odors may develop in items left in the washer after the cycle has ended.

### 9. General Precautions

- If the dispenser drawer is pulled out more than 1-1/2" when the washer is in operation, the washer will shut off.** The Door Lock indicator light will turn off and the door will be unlocked. Slowly close the drawer, and the washer will automatically resume operation.
- Do not slam the washer door closed or try to force the door open when locked (Door Lock light ON).** This could result in damage to the washer.
- DO NOT leave the washer door open.** An open door could entice children to hang on the door or crawl inside the washer.
- To avoid damaging the washer and personal injury, **DO NOT** hang on or lean against the washer door.



- Do not place detergent, bleach or fabric softener containers on top of the washer. They can damage the finish or controls.

## Stain Removal

### Safe Stain Removal Procedures

**WARNING** To reduce the risk of fire or serious injury to persons or property, comply with the basic warnings listed below:

- Read and comply with all instructions on stain removal products.
- Keep stain removal products in their original labeled containers and out of children's reach.
- Thoroughly wash any utensil used.
- Do not combine stain removal products, especially ammonia and chlorine bleach. Dangerous fumes may result.



- Never wash items which have been previously cleaned in, washed in, soaked in or spotted with gasoline, dry cleaning solvents or other flammable or explosive substances because they give off vapors that could ignite or explode.
- Never use highly flammable solvents, such as gasoline, inside the home. Vapors can explode on contact with flames or sparks.

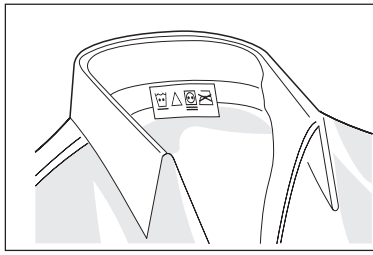

Follow fabric care label instructions.

**For successful stain removal:**

- Remove stains promptly.
- Determine the kind of stain, then follow the recommended treatment in the stain removal chart below.
- To pretreat stains, use a prewash product, liquid detergent, or a paste made from granular detergent and water.
- Use cold water on unknown stains because hot water can set stains.
- Check care label instructions for treatments to avoid on specific fabrics.
- Check for colorfastness by testing stain remover on an inside seam.
- Rinse and wash items after stain removal.

<b>STAIN REMOVAL</b>	
<b>Stain</b>	<b>Treatment</b>
Adhesive tape, chewing gum, rubber cement	Apply ice. Scrape off excess. Place stain face down on paper towels. Saturate with prewash stain remover or nonflammable dry cleaning fluid.
Baby formula, dairy products, egg	Use product containing enzymes to pretreat or soak stains. Soak for 30 minutes or more. Wash.
Beverages (coffee, tea, soda, juice, alcoholic beverages)	Pretreat stain. Wash using cold water and bleach safe for fabric.
Blood	Rinse with cold water. Rub with bar soap. Or, pretreat or soak with product containing enzymes. Wash using bleach safe for fabric.
Candle wax, crayon	Scrape off surface wax. Place stain face down between paper towels. Press with warm iron until wax is absorbed. Replace paper towels frequently. Treat remaining stain with prewash stain remover or nonflammable dry cleaning fluid. Hand wash to remove solvent. Wash using bleach safe for fabric.
Chocolate	Pretreat or soak in warm water using product containing enzymes. Wash using bleach safe for fabric.
Collar or cuff soil, cosmetics	Pretreat with prewash stain remover or rub with bar soap.
Dye transfer on white fabric	Use packaged color remover. Wash using bleach safe for fabric.
Grass	Pretreat or soak in warm water using product containing enzymes. Wash using bleach safe for fabric.
Grease, oil, tar (butter, fats, salad dressing, cooking oils, car grease, motor oils)	Scrape residue from fabric. Pretreat. Wash using hottest water safe for fabric. For heavy stains and tar, apply nonflammable dry cleaning fluid to back of stain. Replace towels under stain frequently. Rinse thoroughly. Wash using hottest water safe for fabric.
Ink	Some inks may be impossible to remove. Washing may set some inks. Use prewash stain remover, denatured alcohol or nonflammable dry cleaning fluid.
Mildew, scorch	Wash with chlorine bleach if safe for fabric. Or, soak in oxygen bleach and hot water before washing. Badly mildewed fabrics may be permanently damaged.
Mud	Brush off dry mud. Pretreat or soak with product containing enzymes.
Mustard, tomato	Pretreat with prewash stain remover. Wash using bleach safe for fabric.
Nail polish	May be impossible to remove. Place stain face down on paper towels. Apply nail polish remover to back of stain. Repeat, replacing paper towels frequently. Do not use on acetate fabrics.
Paint, varnish	WATER BASED: Rinse fabric in cool water while stain is wet. Wash. Once paint is dry, it cannot be removed. OIL BASED AND VARNISH: Use solvent recommended on can label. Rinse thoroughly before washing.
Perspiration	Use prewash stain remover or rub with bar soap. Rinse. Wash using nonchlorine bleach in hottest water safe for fabric.
Rust, brown or yellow discoloration	For spots, use rust remover safe for fabric. For discoloration of an entire load, use phosphate detergent and nonchlorine bleach. <b>Do not use chlorine bleach because it may intensify discoloration.</b>
Shoe polish	LIQUID: Pretreat with a paste of granular detergent and water. PASTE: Scrape residue from fabric. Pretreat with prewash stain remover or nonflammable dry cleaning fluid. Rinse. Rub detergent into dampened area. Wash using bleach safe for fabric.
Urine, vomit, mucus, feces	Pretreat or soak in product containing enzymes. Wash using bleach safe for fabric.

## COMMON WASHING PROBLEMS

Many washing problems involve poor soil and stain removal, residues of lint and scum, and fabric damage. For satisfactory washing results, follow these suggestions provided by The Soap and Detergent Association.

PROBLEM	POSSIBLE CAUSES	SOLUTIONS	PREVENTIVE MEASURES
<b>Blue stains</b>	<ul style="list-style-type: none"> <li>• Undiluted liquid detergent or fabric softener dispensed directly onto fabric.</li> </ul>	<ul style="list-style-type: none"> <li>• If caused by detergent, mix 1 cup (240 ml) white vinegar with 1 quart (.95 L) water in plastic container. Soak item 1 hour. Rinse.</li> <li>• If caused by fabric softener, rub stains with bar soap. Wash.</li> </ul>	<ul style="list-style-type: none"> <li>• Avoid overfilling detergent and fabric softener compartments of dispenser.</li> </ul>
<b>Discoloration, graying</b>	<ul style="list-style-type: none"> <li>• Not enough detergent.</li> <li>• Wash temperature too low.</li> <li>• Incorrect sorting.</li> </ul>	<ul style="list-style-type: none"> <li>• Rewash with correct amount of detergent and hottest water safe for fabric. Add bleach safe for fabric.</li> </ul>	<ul style="list-style-type: none"> <li>• Sort items by soil level and color.</li> <li>• Use correct amount of detergent, hottest water and bleach safe for fabric.</li> </ul>
<b>Greasy, oily stains</b>	<ul style="list-style-type: none"> <li>• Not enough detergent.</li> <li>• Undiluted liquid fabric softener poured directly on fabric.</li> </ul>	<ul style="list-style-type: none"> <li>• Treat with prewash stain remover or liquid detergent.</li> <li>• Increase detergent and water temperature. Rewash.</li> <li>• Rub fabric softener stains with bar soap.</li> </ul>	<ul style="list-style-type: none"> <li>• Use correct amount of detergent and hottest water safe for fabric.</li> <li>• Do not pour liquid fabric softener directly on fabric. See Washing Procedures on adding softener.</li> </ul>
<b>Holes, tears, or snags</b>	<ul style="list-style-type: none"> <li>• Incorrect use of chlorine bleach.</li> <li>• Unfastened zippers, hooks, buckles.</li> <li>• Rips, tears and broken threads.</li> <li>• Overloading the washer.</li> <li>• Degradation of fabric.</li> </ul>	<ul style="list-style-type: none"> <li>• May be irreversible if rips, tears and seams cannot be mended.</li> </ul>	<ul style="list-style-type: none"> <li>• Never pour chlorine bleach directly on fabric.</li> <li>• Check condition of items before washing. See Washing Procedures for preparing, loading and adding chlorine bleach.</li> </ul>
<b>Lint</b>	<ul style="list-style-type: none"> <li>• Incorrect sorting.</li> <li>• Tissues left in pocket.</li> <li>• Overloading the washer.</li> <li>• Not enough detergent.</li> <li>• Undissolved detergent has left a residue resembling lint.</li> <li>• Static cling is attracting lint.</li> <li>• Load washed too long.</li> </ul>	<ul style="list-style-type: none"> <li>• Reduce load size. Rewash using correct water temperature, water level, and amount of detergent.</li> <li>• Add nonprecipitating water conditioner to wash water to remove detergent residue.</li> <li>• Add liquid fabric softener to final rinse.</li> <li>• Dry load in dryer.</li> <li>• Remove lint with lint brush or roller.</li> </ul>	<ul style="list-style-type: none"> <li>• See Washing Procedures for sorting and preparing the wash load.</li> <li>• Do not overload washer.</li> <li>• Use correct temperature and amount of detergent, water and wash time.</li> </ul>
<b>Pilling</b> (Fibers break off, ball up and cling to fabric.)	<ul style="list-style-type: none"> <li>• Pilling is normal with synthetic and permanent press fabrics. This is due to abrasion from normal wear.</li> </ul>	<ul style="list-style-type: none"> <li>• Use a lint brush or shaver to remove pills.</li> </ul>	<ul style="list-style-type: none"> <li>• Use fabric softener in the washer to lubricate fibers.</li> <li>• When ironing, use spray starch or fabric finish on collars/cuffs.</li> <li>• Turn items inside out to reduce abrasion.</li> </ul>
<b>Residue or powder on dark items; stiff, harsh fabrics.</b>	<ul style="list-style-type: none"> <li>• Undissolved detergent.</li> <li>• Some nonphosphate granular detergents can combine with hard water minerals to form a residue.</li> <li>• Overloading the washer.</li> </ul>	<ul style="list-style-type: none"> <li>• Rewash load.</li> </ul>	<ul style="list-style-type: none"> <li>• Increase water temperature using hottest water safe for fabric.</li> <li>• Do not overload washer.</li> <li>• Use liquid detergent or use nonprecipitating water conditioner with nonphosphate granular detergent.</li> </ul>
<b>Wrinkling</b>	<ul style="list-style-type: none"> <li>• Overloading the washer.</li> <li>• Incorrect wash cycle for wash load.</li> </ul>	<ul style="list-style-type: none"> <li>• Reduce load size.</li> <li>• Rinse in cold water with liquid fabric softener using the Perm Press or Delicate cycle.</li> </ul>	<ul style="list-style-type: none"> <li>• Do not overload washer.</li> <li>• Remove items from washer as soon as cycle is completed.</li> <li>• Use liquid fabric softener.</li> </ul>
<b>Yellow buildup of body soil on synthetic fabrics</b>	<ul style="list-style-type: none"> <li>• Agitation time too short.</li> <li>• Wash water temperature too low.</li> <li>• Not enough detergent.</li> </ul>	<ul style="list-style-type: none"> <li>• Soak in detergent booster or product containing enzymes.</li> <li>• Wash in hot water (120°F/49°C) using full permanent press cycle. Increase detergent. Add bleach or treat with color remover.</li> </ul>	<ul style="list-style-type: none"> <li>• Select correct wash cycle.</li> <li>• Use correct amount of detergent.</li> <li>• Wash synthetics frequently using hot or warm water.</li> </ul>
<b>Yellow or brown rust stains</b>	<ul style="list-style-type: none"> <li>• Iron or manganese in water supply, water pipes, or water heater.</li> </ul>	<ul style="list-style-type: none"> <li>• To restore discolored load of whites, use rust remover safe for fabric.</li> <li>• <b>Do not use chlorine bleach to remove rust stains. It may intensify discoloration.</b></li> </ul>	<ul style="list-style-type: none"> <li>• Use nonprecipitating water softener.</li> <li>• Before washing, run hot water for a few minutes to clear lines.</li> <li>• Drain water heater occasional</li> <li>• For an ongoing problem, install an iron filter in your water supply system.</li> </ul>

## Drying Procedures

- Follow the guidelines below for preparing the load for drying.
- Read the **Dryer Operating Instructions** for operating your specific model.
- **Always read and follow fabric care labels and laundry product labels.**

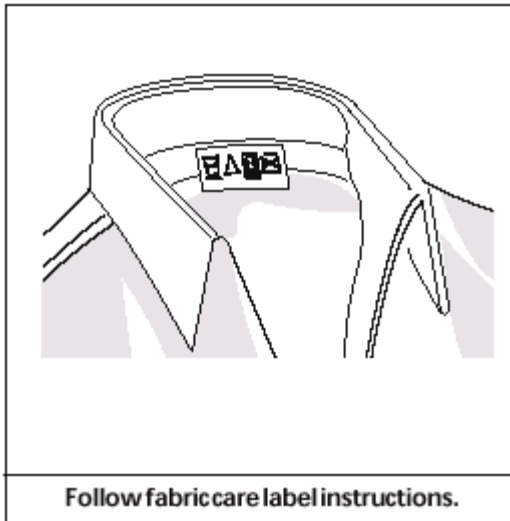

**WARNING** To reduce the risk of fire, electrical shock, or injury to persons, read **Important Safety Instructions**, before operating this dryer.

### 1. Prepare items for drying.

- Dry items of similar fabric, weight and construction in the same load.
- Separate dark items from light-colored items. Separate items that shed lint from those that attract lint. If an item sheds lint, turn it inside out.
- Be sure buckles, buttons and trim are heatproof and won't damage the drum finish. Close zippers, fasten hooks and Velcro®-like fasteners. Tie strings and sashes to prevent tangling.
- If possible, turn pockets inside out for even drying.
- Check for stains which may not have been removed in washing. Dryer heat may permanently set some stains. Repeat stain removal process before drying.
- Place small items in a mesh bag to prevent tangling and for easy removal.

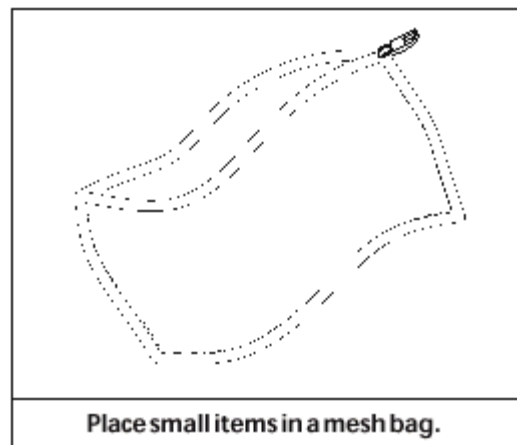

### 2. Check that lint screen is clean and in place.

### 3. Load the dryer.

- The average load will fill the drum 1/3 to 1/2 full. Items need room to tumble freely for even drying and less wrinkling. **Do not overload dryer.**

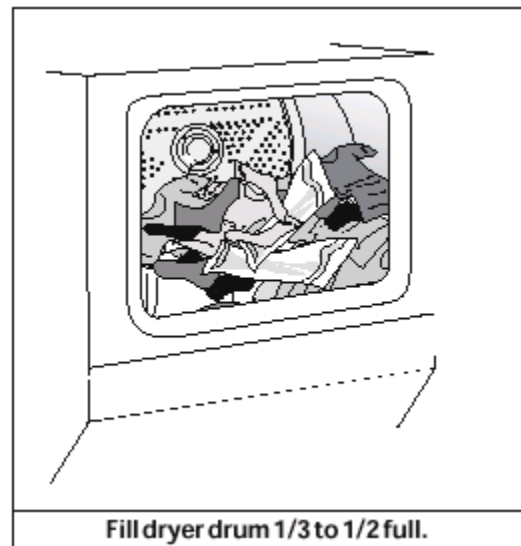

- When drying large items, dry only 2 or 3 at a time. Fill out the load with small and medium sized items.
- For delicate or very small loads, add 2 lint-free towels for better drying, less wrinkling, and to prevent grease stains caused by fabric softener sheets.
- Do not overdry items. Overdrying can cause wrinkling, shrinkage, harshness, and a build-up of static electricity, which can produce more lint.
- If desired, add a dryer fabric softener sheet.

**4. Close the dryer door and set dryer controls (some models).**

See **Dryer Operating Instructions** for your specific model controls.

**5. Turn cycle selector clockwise to the desired setting.**

**6. Start the dryer.**

- Push Start Button for 2 seconds or turn the START knob clockwise to ON, hold for 1-2 seconds and release.
- To add or remove items when the dryer is running, open the door. The dryer will always stop when the door is opened. Allow the drum to come to a complete stop before reaching inside.
- To restart dryer, close the door then push the Start Button for 2 seconds or turn the START knob clockwise to ON, hold for 1-2 seconds and release.
- The dryer will not start if the cycle selector is in the OFF position.

**7. When the cycle ends, remove items immediately and hang or fold.** If load is removed before the cycle ends, turn cycle selector to OFF.

**Features**

**Cycle Signal Control (some models)**

When the Cycle Signal Control is ON, a signal will sound at the end of each cycle and during the Press Saver setting (some models). The volume is adjustable on some models.

**Drum Light (some models)**

A drum light will come on whenever the door is opened to illuminate the dryer drum during loading and unloading. Closing the door turns off the light.

**Drying Rack (some models)**

Use the drying rack to dry items which should not be tumble dried.

1. Open the dryer door and remove the lint screen.
2. Insert drying rack into the dryer drum. Place the front bar under the lip of the lint screen opening.

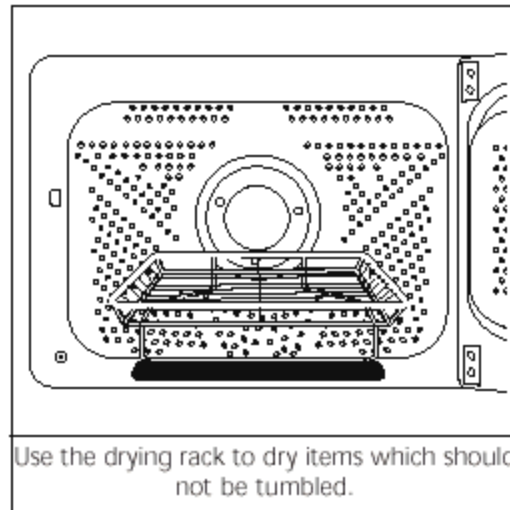

3. Place items to be dried on top of rack. Weight should not exceed 10 lbs. Leave space between items, but do not let items hang over the sides or through the grids. Do not tumble other items when using the drying rack.
4. Select a timed dry setting best suited for items being dried. Use only the Air Fluff (no heat) temperature setting for items containing plastic, foam rubber, rubber-like materials, feathers or down.
5. When items are dry, remove the rack and replace the lint screen. If lint screen is not in place, tumbling items could enter the exhaust system and cause damage to the dryer.



---

## Common Drying Problems

Many drying problems involve poor cleaning results, poor soil and stain removal, residues of lint and scum, and fabric damage. For satisfactory drying results, follow these suggestions provided by The Soap and Detergent Association.

---

PROBLEM	POSSIBLE CAUSES	SOLUTIONS	PREVENTIVE MEASURES
<b>Greasy, oily stains</b>	<ul style="list-style-type: none"><li>• Fabric softener sheet.</li></ul>	<ul style="list-style-type: none"><li>• Rub fabric softener stains with bar soap. Rinse and rewash.</li></ul>	<ul style="list-style-type: none"><li>• Add a few bath towels to small loads for proper tumbling.</li><li>• Some "silk-like" fabrics should be air dried.</li><li>• Use proper drying temperature.</li><li>• Place fabric softener sheet on top of load before starting the dryer.</li></ul>
<b>Lint</b>	<ul style="list-style-type: none"><li>• Overloading.</li><li>• Overdrying causes static electricity.</li><li>• Lint screen not clean when cycle began.</li><li>• Lint is attached to "pills."</li></ul>	<ul style="list-style-type: none"><li>• Reduce load size and rewash using liquid fabric softener in the final rinse.</li><li>• Or, add a fabric softener sheet and tumble without heat.</li><li>• Use lint brush or roller to remove lint.</li></ul>	<ul style="list-style-type: none"><li>• Do not overload dryer.</li><li>• Use fabric softener in washer or dryer to reduce static electricity.</li><li>• Remove items when they are slightly damp to avoid overdrying.</li><li>• Check that lint screen is clean and in place.</li></ul>
<b>Pilling</b> (Fibers break off, ball up and cling to fabric.)	<ul style="list-style-type: none"><li>• Pilling is normal with synthetic and permanent press fabrics. This is due to abrasion from normal wear.</li></ul>	<ul style="list-style-type: none"><li>• Use a lint brush or shaver to remove pills.</li></ul>	<ul style="list-style-type: none"><li>• Use fabric softener to lubricate fibers.</li><li>• When ironing, use spray starch or fabric finish on collars and cuffs.</li><li>• Turn items inside out to reduce abrasion.</li></ul>
<b>Shrinking</b>	<ul style="list-style-type: none"><li>• Overdrying.</li></ul>	<ul style="list-style-type: none"><li>• Irreversible condition.</li></ul>	<ul style="list-style-type: none"><li>• Follow fabric care label directions.</li><li>• If shrinking is a concern, check load often.</li><li>• Remove items while slightly damp and hang or lay flat to complete drying.</li><li>• Block knits into shape.</li></ul>
<b>Wrinkling</b>	<ul style="list-style-type: none"><li>• Overloading.</li><li>• Leaving items in dryer after cycle ends.</li></ul>	<ul style="list-style-type: none"><li>• Reduce load size and tumble at medium or low heat for 5-10 minutes.</li><li>• Remove items immediately. Hang or fold.</li></ul>	<ul style="list-style-type: none"><li>• Do not overload dryer.</li><li>• Remove items as soon as cycle ends.</li></ul>

---



cycle ends. Excess wrinkling, color transfer, and odors may develop in items left in the washer.

- Before cleaning the washer interior, **unplug the electrical power cord** to avoid electrical shock hazards.
- Dry around the washer door opening, flexible gasket, and door glass. These areas should always be clean to ensure a water tight seal.
- When extremely soiled items have been washed, a dirty residue may remain on the drum. Remove this by wiping the drum with a nonabrasive household cleanser. Rinse thoroughly with water.
- The plastic drum vanes may become stained from fabric dye. Clean these parts with a nonabrasive household cleanser. This prevents dye transfer to future loads.

## Care and Cleaning

### Inside the Dryer

- Clean the dryer lint screen after every load. Lint build-up in the screen restricts air flow, which causes longer drying times. The screen is located at the bottom of the door opening. Remove by pulling straight up. Remove the lint and replace the screen.

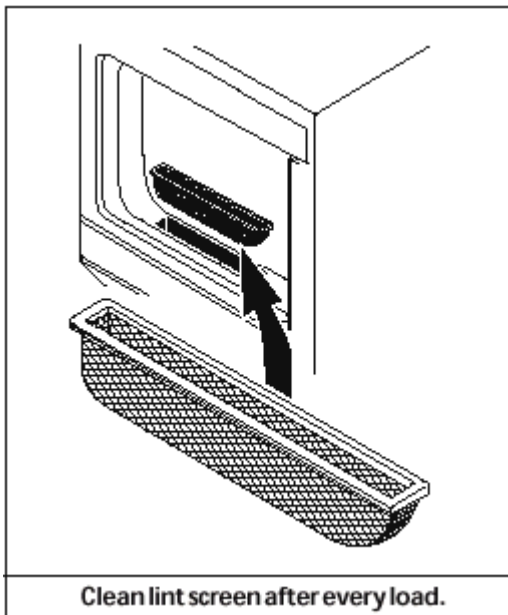

- Occasionally a waxy build-up may form on the lint screen from using dryer-added fabric softener sheets. To remove this build-up, wash the lint screen in warm, soapy water. Dry thoroughly and replace. Do not operate the dryer without the lint screen in place.

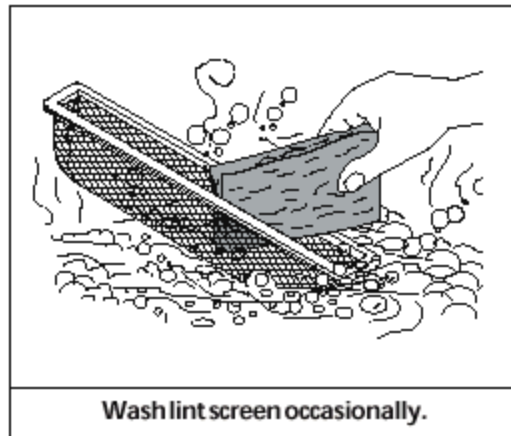

- If the dryer drum becomes stained from noncolorfast fabrics, clean the drum with a damp cloth and a mild liquid household cleanser. Remove cleanser residue before drying the next load.
- Every 18 months an authorized servicer should clean the dryer cabinet interior and exhaust duct. These areas can collect lint and dust over time. An excessive amount of lint build-up could result in inefficient drying and possible fire hazard.

### Outside

- When laundering is completed, wipe cabinet with a damp cloth. Turn water faucets off to prevent pressure build-up in the hoses.
- Clean the cabinet with mild soap and water. **Never use harsh, gritty or abrasive cleansers.** If the cabinet becomes stained, clean with diluted chlorine bleach [1/2 cup (120 ml) in 1 quart (.95 L) water]. Rinse several times with clear water.
- Remove glue residue from tape or labels with a mixture of warm water and mild detergent. Or, touch residue with the sticky side of the tape or label.
- **Before moving the laundry center,** place a strip of cardboard or thin fiberboard under the front leveling legs to prevent floor damage.

## Care and Cleaning

**WARNING** To reduce risk of fire or serious injury to persons or property, comply with the basic warnings listed in *Important Safety Instructions*, and those listed below.

- Before cleaning the washer or dryer interior, **unplug the electrical power cord** to avoid electrical shock hazards.
- Do not use any type of spray cleanser when cleaning the dryer interior. Hazardous fumes or electrical shock could occur.

### Cleaning the Dispenser Drawer Area

Detergent and fabric softener may build up in the dispenser drawer. Residue should be removed once or twice a month.

- Remove the drawer by first sliding the safety latch to the right, then pulling the drawer out until it stops. (Figure 1)

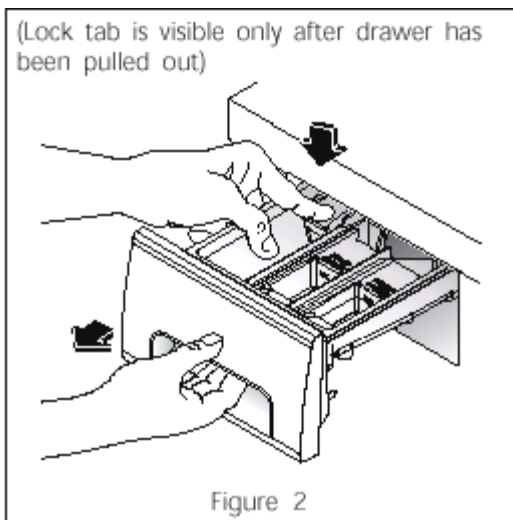
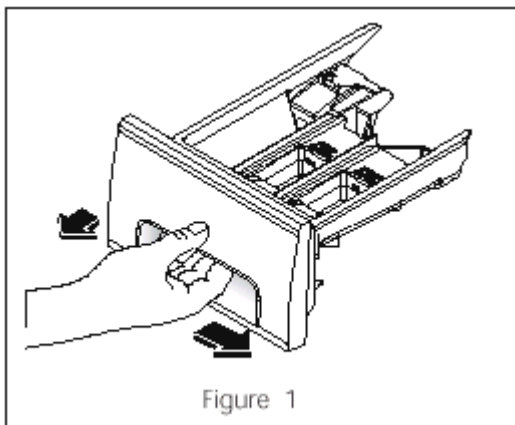

- Reach back into the left rear corner of the drawer cavity and press down firmly on the lock tab (left rear portion of the drawer). Pull out the drawer. (Figure 2)
- Remove the inserts from the bleach and fabric softener compartments. (Figure 3)

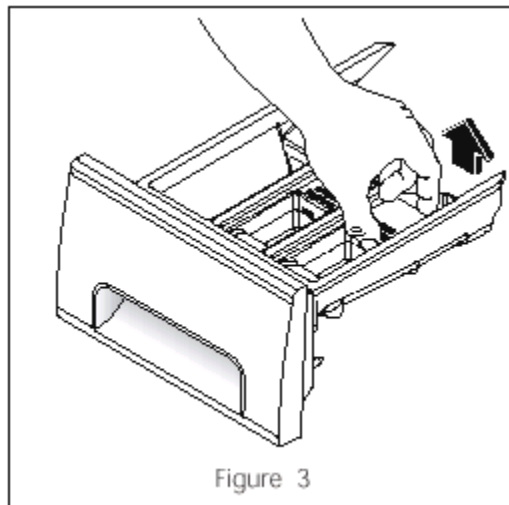

- Rinse the drawer and inserts with hot tap water to remove traces of accumulated powders and liquids. Large amounts of fabric softener residue may indicate improper dilution or more frequent cleaning is required.
- To clean the drawer opening, use a small brush to clean the recess. Remove all residue from the upper and lower parts of the recess. (Figure 4)

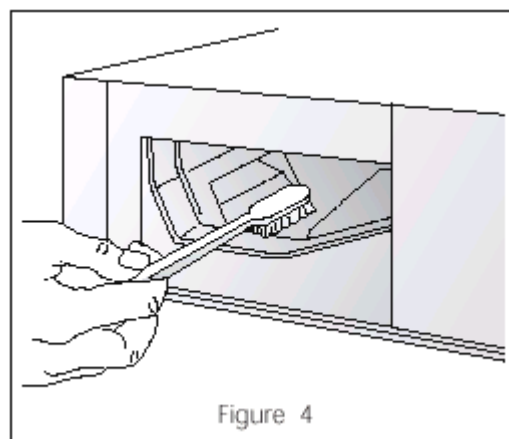

- Return the bleach and fabric softener inserts to their proper compartments. Replace the dispenser drawer and run the short wash cycle without any wash load in the drum.

### Inside

- Remove items from the washer as soon as the



### Winterizing Instructions

If the laundry center is stored in an area where freezing can occur or moved in freezing temperatures, follow these winterizing instructions to prevent damage to the laundry center:

1. Turn off water supply faucets.
2. Disconnect hoses from water supply and drain water from hoses.
3. Plug electrical cord into a properly grounded electrical outlet.
4. Add 1 gallon nontoxic recreational vehicle (RV) antifreeze to empty wash drum. Close door.
5. Set cycle selector knob at a spin setting. Pull out knob and let washer spin for 1 minute to drain out all water. Not all of the RV antifreeze will be expelled.
6. Push in knob, unplug electrical power cord, dry tub interior, and close door.
7. Store washer in an upright position.
8. To remove antifreeze from washer after storage, run empty washer through a complete cycle using detergent. **Do not add wash load.**

### Avoid Service Checklist

Before calling for service, review this list. It may save both time and expense. The list includes common concerns that are not the result of defective workmanship or materials in this washer.

#### OCCURRENCE WASHER

#### POSSIBLE CAUSE / SOLUTION

"Clicking" noise.	<ul style="list-style-type: none"> <li>• A normal sound made by the timer.</li> </ul>
High pitch "jet engine" noise.	<ul style="list-style-type: none"> <li>• A certain amount of motor whine is normal during the spin cycle.</li> </ul>
Rattling and clanking noise.	<ul style="list-style-type: none"> <li>• Foreign objects such as coins or safety pins may be in drum or pump. Stop washer and check drum. If noise continues after washer is restarted, objects may be in pump. Call your authorized servicer.</li> <li>• Belt buckles and metal fasteners are hitting wash drum. To prevent unnecessary noise and damage to drum, fasten fasteners and turn items inside out.</li> </ul>
Squealing sound or hot rubber odor.	<ul style="list-style-type: none"> <li>• Washer is overloaded. Do not overload washer. Stop washer and reduce load.</li> </ul>
Thumping sound.	<ul style="list-style-type: none"> <li>• Heavy wash loads may produce a thumping sound. This is usually normal. If sound continues, washer is probably out of balance. Stop washer and redistribute wash load.</li> </ul>

## OCCURRENCE

## POSSIBLE CAUSE / SOLUTION

---

### Vibrating noise.

- Washer is not resting firmly on floor. Move washer so it rests firmly on floor. Adjust leveling legs. See INSTALLATION INSTRUCTIONS for details.
- Shipping bolts and foam block have not been removed during installation. See INSTALLATION INSTRUCTIONS for removing shipping bolts and foam block.
- Wash load unevenly distributed in drum. Stop washer and rearrange wash load.

---

### Washer does not start.

- Electrical power cord may not be plugged in or connection may be loose. Make sure plug fits tightly in wall outlet.
- House fuse blown, circuit breaker tripped, or a power outage has occurred. Reset circuit breaker or replace fuse. Do not increase fuse capacity. If problem is a circuit overload, have it corrected by a qualified electrician. If problem is a power outage, call local electric company.
- Water supply faucets are not turned on. Turn on water supply faucets.
- Cycle selector is not in correct position. Move indicator clockwise slightly. Pull out knob.
- Motor is overheated. Washer motor will stop if it becomes overheated. It will automatically restart after a cool down period of up to 30 minutes (if washer has not been manually turned off).
- Dispenser drawer is not completely closed. Close dispenser drawer.

---

### Washer won't spin.

- Washer door is not completely closed. Close door completely.
- Dispenser drawer is not completely closed. Close dispenser drawer.
- Load is too small. Add 1 or 2 similar items to help balance the load.

---

### Residue left in tub.

- Heavily soiled items. Wipe drum with a nonabrasive household cleanser, then rinse. Shake or brush excess dirt and sand from items before washing.

---

### Water collects in bleach and fabric softener compartments.

- This is a result of the siphoning action and is part of the normal operation of the washer. Water may be removed by removing the dispenser drawer into the empty drum or sink.

---

### Wash load too wet after spin.

- Washer is overloaded. Do not overload washer. See **Washing Procedures**.
- Load is too small. Add 1 or 2 similar items to help balance the load.
- Load is out of balance. Rearrange load to allow proper spinning.
- Drain hose is kinked. Straighten drain hose.

---

### Water does not enter washer or it enters slowly.

- Water supply is not adequate in area. Check another faucet in the house. Wait until water supply and pressure increase.
  - Water supply faucets are not completely open. Fully open hot and cold faucets.
  - Water is being used elsewhere in the house. Water pressure must be at least 30 psi (260 kPa). Avoid running water elsewhere while washer is filling.
  - Water inlet hoses are kinked. Straighten hoses.
-

O  
W  
R  
E  
C  
t  
a  
e

C  
U  
R  
N  
E

a  
m  
o  
r  
h  
o  
w  
t  
r  
i  
s  
n  
o  
h  
t  
e  
n  
u  
h

P  
S  
H  
E  
U  
E  
L  
T  
O

w  
r  
s  
s  
a  
c  
o

s  
e  
.  
e  
s  
r  
t  
a  
e

m  
e  
a  
u  
e  
t  
e  
r  
y  
a  
c  
t  
i  
h  
a  
d

a  
e  
m  
m  
t  
r

t  
o  
o  
g  
.

Water in washer does not drain or drains slowly.

Water leaks.

Incorrect wash and rinse temperatures.

Water is entering washer, but tub does not fill.

O  
S  
B  
E  
C  
A  
S  
/  
S  
O  
U  
I  
N

o  
w  
t  
r  
h  
e  
t  
r  
i  
s  
e  
t  
o  
l  
o  
i  
a  
d  
i  
t  
n  
e  
f  
r  
m  
w  
a  
h  
r  
M  
a  
u  
e  
h  
o  
w  
t  
r  
t  
e  
p  
r  
t  
r  
a  
n  
a  
b  
f  
u  
e  
w  
t  
c  
n  
y  
o  
r  
m  
e  
t  
h  
r  
o  
e  
e  
.

OCCURRENCE DRYER	POSSIBLE CAUSE	SOLUTION
<b>Dryer does not start.</b>	Electrical power cord is not securely plugged in or plug may be loose.	Make sure the plug fits tightly in wall outlet.
	House fuse blown or circuit breaker tripped.	Reset circuit breaker or replace fuse.  Make sure electrical line is not overloaded and the dryer is on a separate circuit.
	Thermal limiter tripped.	Call authorized service person for replacement.
<b>Dryer runs but won't heat.</b>	There are 2 house fuses in the dryer circuit. If 1 of the 2 fuses is blown, the drum may turn but the heater will not operate.	Replace fuse.
	Gas supply valve is not open (gas models).	Check to make sure supply valve is open. See INSTALLATION INSTRUCTIONS for procedure.
	Dryer does not have enough air supply to support the burner flame (gas models).	See INSTALLATION INSTRUCTIONS.
	LP gas supply tank is empty or there has been a utility interruption of natural gas (gas models).	Refill or replace tank.  Dryer should heat when utility service is restored.
<b>Drying cycle takes too long, outside of the dryer feels too hot or smells hot.</b>	Lint screen is clogged with lint.	Make sure all lint has been removed from the dryer lint screen before starting each cycle.
	Exhaust duct requirements have not been met.	Exhaust duct must be at least 4 inches in diameter and made of rigid or flexible metal.  When in place, the duct must have no more than two 90° bends and must not exceed length listed in INSTALLATION INSTRUCTIONS.
	Electric dryer is connected to a 208 volt circuit.	Drying time will be 20% longer than drying on a 240 volt circuit.
	Drying procedures have not been followed.	See <b>Drying Procedures</b> .
	Outside exhaust hood or exhaust duct may be clogged or restricted.	Clean out any obstruction.
	High humidity.	Use a dehumidifier near the dryer.
<b>Excessive wrinkling.</b>	Dryer is overloaded.	Do not overload. See <b>Drying Procedures</b> .
	Items left in dryer too long.	Remove items as soon as cycle ends.
	Insufficient sorting of items.	See <b>Drying Procedures</b> .
	Drying temperature too high.	Follow fabric care label instructions.

**FRIGIDAIRE TUMBLE ACTION  
LAUNDRY CENTER WARRANTY**

**Sample warranty - always check  
warranty with product**

	WARRANTY PERIOD	FRIGIDAIRE, THROUGH ITS AUTHORIZED SERVICERS, WILL:	THE CONSUMER WILL BE RESPONSIBLE FOR:
<b>FULL ONE-YEAR WARRANTY</b>	One year from original purchase date.	Pay all costs for repairing or replacing any parts of this appliance which prove to be defective in materials or workmanship.	Costs of service calls that are listed under <b>NORMAL RESPONSIBILITIES OF THE CONSUMER.*</b>
<b>LIMITED 2ND- 5TH YEARWARRANTY</b>	Limited 2-5 years from original purchase date.	Provide a replacement without charge for the motor, driven pulley or motor controller which proves to be defective.	<b>Labor and cost of service calls that are listed under NORMAL RESPONSIBILITIES OF THE CONSUMER</b>
<b>LIMITED 2ND-25TH YEAR INNER WASH BASKETWARRANTY (Excluding Alaska)</b>	Limited 2-25 years from original purchase date.	Provide a replacement without charge for an inner wash basket that breaks due to defective materials or workmanship.	<b>Labor and cost of service calls that are listed under NORMAL RESPONSIBILITIES OF THE CONSUMER</b>
<b>LIMITED WARRANTY (Applicable to the State of Alaska)</b>	Time period listed above.	All of the provisions of the full and limited warranties above and the exclusions listed below apply.	Costs of the technician's travel to the home and any costs for pick up and delivery of the appliance required because of service.

Your appliance is warranted by Frigidaire Home Products, a division of White Consolidated Industries, Inc. We authorize no person to change or add to any of our obligations under this warranty. Our obligations for service and parts under this warranty must be performed by Frigidaire or an authorized Frigidaire servicer.

**NORMAL RESPONSIBILITIES OF THE CONSUMER**

**This warranty applies only to products in ordinary household use, and the consumer is responsible for the items listed below:**

1. Proper use of the appliance in accordance with instructions provided with the product.
2. Proper installation by an authorized servicer in accordance with instructions provided with the appliance and in accordance with all local plumbing, electrical and/or gas codes.
3. Proper connection to a grounded power supply of sufficient voltage, replacement of blown fuses, repair of loose connections or defects in house wiring.
4. Expenses for making the appliance accessible for servicing, such as removal of trim, cupboards, shelves, etc., which are not a part of the appliance when it was shipped from the factory.
5. Damages to finish after installation.
6. Replacement of light bulbs and/or fluorescent tubes (on models with these features).

**EXCLUSIONS**

**This warranty does not cover the following:**

1. CONSEQUENTIAL OR INCIDENTAL DAMAGES SUCH AS PROPERTY DAMAGE AND INCIDENTAL EXPENSES RESULTING FROM ANY BREACH OF THIS WRITTEN OR ANY IMPLIED WARRANTY.  
*Note: Some states do not allow the exclusion or limitation of incidental or consequential damages, so this limitation or exclusion may not apply to you.*
2. Service calls which do not involve malfunction or defects in workmanship or material, or for appliances not in ordinary household use. The consumer shall pay for such service calls.
3. Damages caused by services performed by servicers other than Frigidaire or its authorized servicers; use of parts other than genuine Frigidaire Home Products parts; obtained from persons other than such servicers; or external causes such as abuse, misuse, inadequate power supply or acts of God.
4. Products with original serial numbers that have been removed or altered and cannot be readily determined.

**IF YOU NEED SERVICE**

Keep your bill of sale, delivery slip, or some other appropriate payment record. The date on the bill establishes the warranty period should service be required. If service is performed, it is in your best interest to obtain and keep all receipts. This written warranty gives you specific legal rights. You may also have other rights that vary from state to state. Service under this warranty must be obtained by contacting Frigidaire Home Products:

**800 • 944 • 9044**  
Frigidaire Home Products  
P.O. Box 212378  
Augusta, GA 30917



Product features or specifications as described or illustrated are subject to change without notice. All warranties are made by White Consolidated Industries, Inc. This warranty applies only in the 50 states of the U.S.A. and Puerto Rico.



## SECTION E - DRYER SECTION OPERATION

### Airflow Electric Dryers:

Room air enters the dryer section through a louvered panel in the rear of the laundry center.

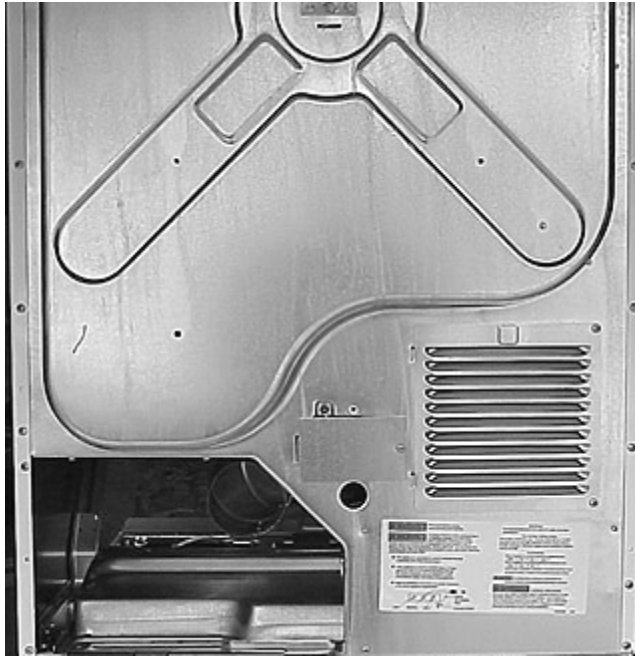

Once inside the dryer cavity, the air is drawn between the rear wall of the dryer and the plenum. The holes in the plenum allow the air to be drawn across the heating element. In any cycle, other than Air Fluff, the heating element heats the air as it passes through.

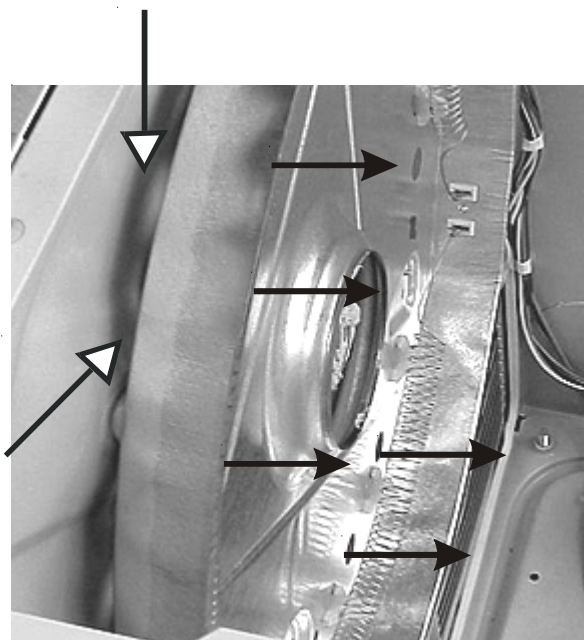

The air then is drawn into the drum through the holes in the rear of the drum.

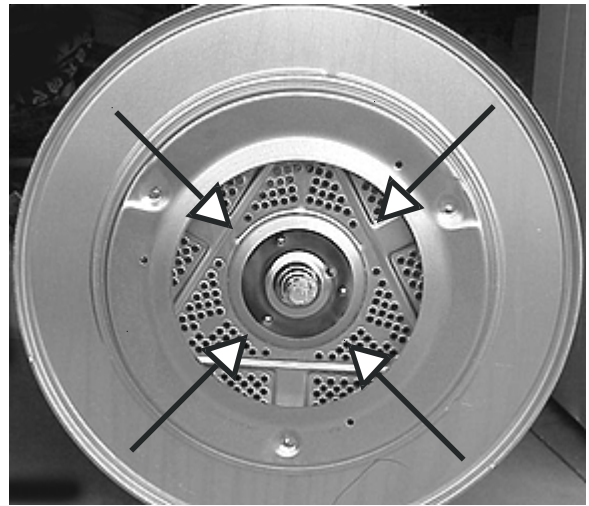

The air passes through the drum picking up moisture and is drawn into the air duct in the door through the lint filter into the ductwork at the front of the dryer.

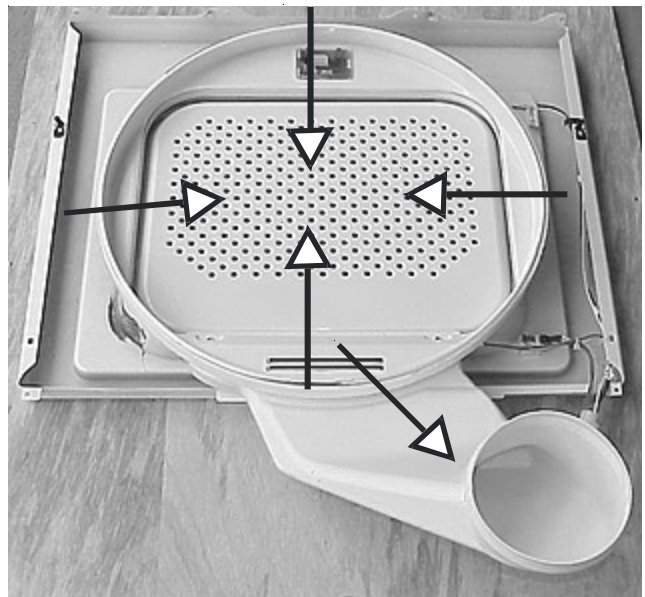

The air enters the fan housing and is pushed out the exhaust vent to the outside of the house.

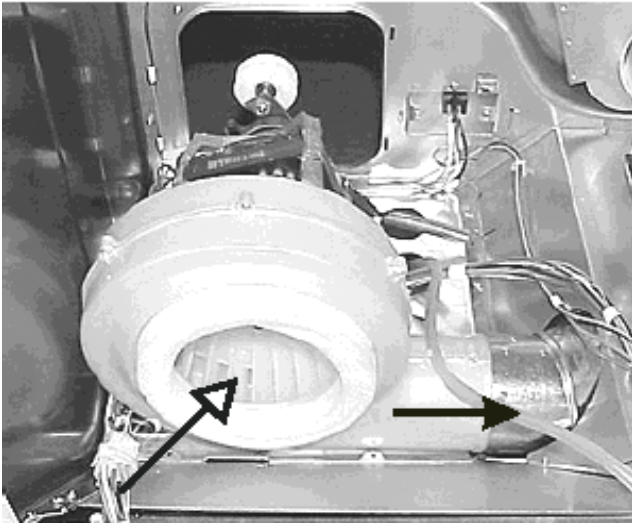

### Airflow Gas Dryers:

The airflow in gas dryers is the same electric dryer as except for the heat source and the rear of the drum. The air enters the cavity through the louvered opening in the rear of the laundry center. The air is then pulled across the gas burner, through the burner chamber and is ducted to the rear of the drum.

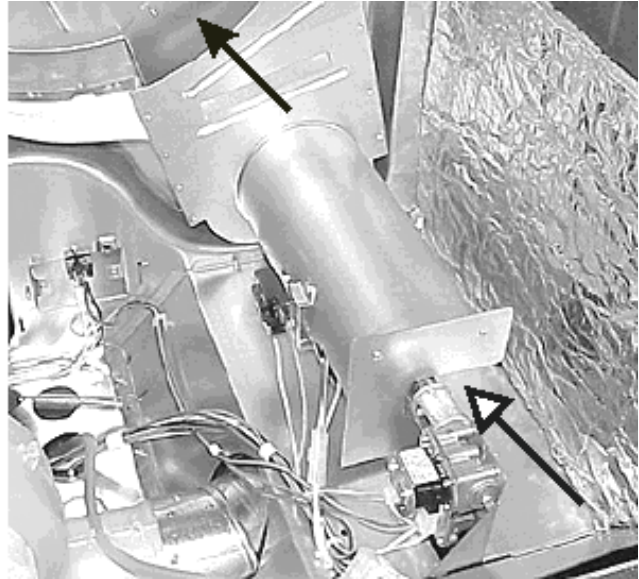

The drum is the same as in the electric dryer except it does not have the heat baffle on it

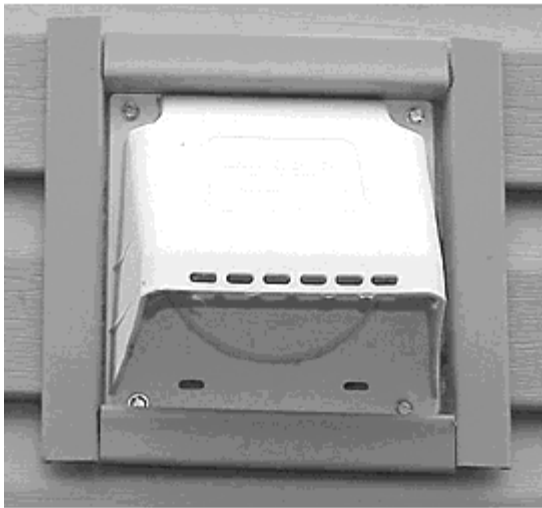

### Airflow Problems:

Airflow problems are usually caused by restrictions, leaks or short unrestricted vents resulting in longer drying times, hotter dryer surfaces and in extreme cases will cause the thermal limiter to open on electric dryers.

## Restrictions:

Restrictions can occur any place in the airflow system, but the most common are:

1. Installing the laundry center in a small inclosed area; such as a closet without a louvered door, that reduces the intake air.
2. Fan problems caused by either a slow running motor, a broken or deformed fan blade or a deformed fan housing.
3. A lint restriction in the lint screen area. Operator may not be cleaning the lint screen before using.
4. A restriction in the exhaust system in the house caused by the design of the vent, such as; the diameter of the vent pipe being to small, to long or to many right angles, a collapsed or lint restricted vent pipe.

**Note:** Problems caused by the vent pipe in the house are not cover under the product warranty.

## Air Leaks:

Two types of air leaks may occur.

1. Air being drawn in, usually around the door opening, between the drum and the front panel, or around the foam seal between the front duct and the blower housing, replaces some of the air being drawn through the drum and lower the efficiency of the dryer.

**Note:** An air leak that occurs around the door opening or between the drum and the front panel usually will cause lint to build up on the inner panel of the door.

2. Air being pushed out, usually in the blower housing or vent pipe inside the dryer, allows some of the moisture that has been removed from the clothes to be recirculate.

## Short Unrestricted Vents:

The venting system in the dryer is designed to operate under some back pressure. This back pressure is needed to slow the airflow and allow the air to be heated before it passes through the clothes.

**Note:** With short direct vent runs; such as you have when the dryer is installed against an outside wall, use a 2 1/2" vent cap rather than a 4" vent cap.

## Electrical Operation: (Electric Dryer)

**Note:** Always refer to the wiring diagram or schematic with the product.

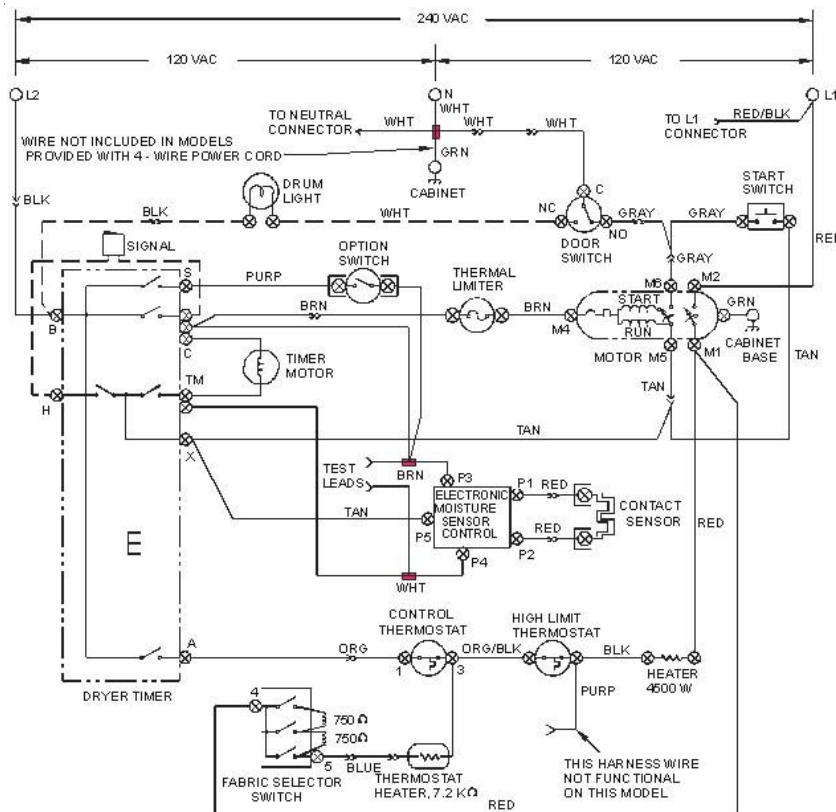



## Auto Dry Cycle

When the dryer is connected to electrical power, line 2 is connected to terminal B of the timer and one side of the drum light. When the timer is set to the Auto Dry cycle, contacts B to C and B to A are closed. This provides power at the start of the cycle to four circuits; the drive motor circuit, timer motor circuit, electronic moisture sensor control circuit and the heating circuit.

### Drive Motor Circuit:

When contacts B to C are closed, line 2 is applied through the thermal limiter (a non resettable fuse mounted on the rear wall of the dryer) to terminal M4 of

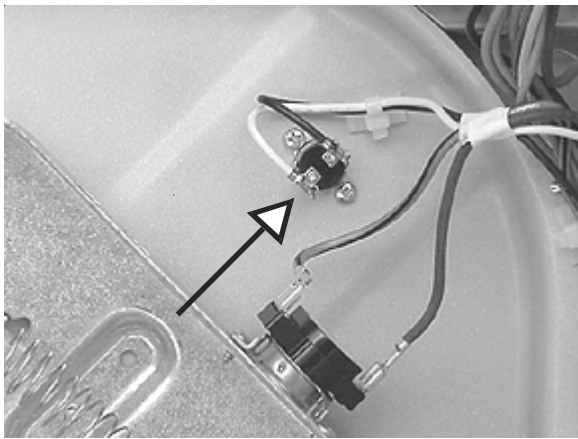

the drive motor. Terminal M4 is connected in the motor to one side of the thermal overload (The thermal overload protects the motor from being damaged by overheating.) The other side of the thermal overload is connected to one end of both the run winding and the start winding of the drive motor. When the motor is not turning, the other end of the start winding is connected internally to terminal M5 of the motor through the NC contact of the motor centrifugal switch. The other end of the run winding is also connected internally to terminal M5.

When the motor is not turning, the start winding and the run winding are connected in parallel. Terminal M5 of the motor is connected to the start switch which is connected to neutral through the door switch. When the start switch is activated, with the dryer door closed, line 2 to neutral voltage is applied across both the start and run windings of the drive motor. With power applied to both the start and run windings, the motor starts to turn.

When the speed of the motor reaches about 80% of its normal run speed, the contacts of the centrifugal switch change from NC to NO, opening the circuit to the start winding and connecting the run winding to motor terminal M6. Terminal M6 is connected to neutral through the door switch. The start winding is now out of the circuit.

Since the run winding circuit is bypassing the start switch, the switch can be released without interrupting power to the run winding.

The drive motor performs two tasks in the dryer. A pulley attached to one end of the motor shaft uses a belt to drive the dryer drum. The blower wheel is attached to the other end of the motor shaft and pulls the air through the clothes forcing it out the exhaust vent.

### The Timer Motor Circuit:

When timer contacts B to C close, line 2 is applied to one end of the timer motor winding. The other end of the timer motor winding is connected to terminal TM of the timer. Terminal TM is connected to neutral through terminals P4 and P5 of the electronic moisture sensor control, the start switch (when the motor is not running) and through the centrifugal switch in the motor (when the motor is running). Current flow through the timer motor in the auto dry cycle, is controlled by the electronic moisture sensor control. The control circuit in the electronic moisture sensor control is in series with the timer motor. The electronic moisture sensor control measures the capacitance between the two sensor bars located in the vent cover.

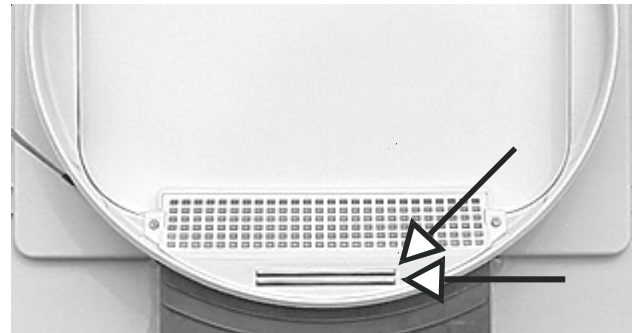

When wet clothes are placed in the dryer, the clothes touch the sensor bars and the moisture lowers the capacitance between the bars. The electronic moisture sensor control reads this and increases the resistance between terminals P4 and P5. When resistance is increased in a series circuit, the current flow in the circuit is reduced. The increase in resistance inside the control lowers the current flow through the timer motor below the level needed to operate the motor, preventing the timer from advancing. As the moisture is removed from the clothes, the capacitance between the bars increases. When the increase in capacitance satisfies the electronic moisture control, the electronic moisture control removes the resistance between terminals P4 and P5, increasing the current flow through the timer motor, causing the motor to advance.

## Automatic Press Saver Option

If the Press Saver switch is turned ON at the end of the auto cycle, the timer will advance through the Off position and add 15 minutes to the cycle. During that 15 minutes, contacts B to A in the timer are open and the dryer operates without heat. The end of cycle signal will sound every 5 minutes.

**Note:** In the auto regular cycle, the timer motor can run for 58.75 minutes. The cycle time will be 58.75 minutes plus the timer motor current flow is being shunted by the electronic moisture sensor control.

## The Heat Circuit:

Timer contacts B to A connect line 2 to terminal 1 of the control thermostat. The control thermostat senses the temperature of the air in the blower housing and heat, if any, from the thermostat heater. The control thermostat controls the temperature in the dryer by opening and closing the heater circuit. When the temperature in the drum is below the cycle temperature, contacts 1 and 3 of the thermostat are closed, connecting line 2 to the thermostat heater and the high limit thermostat. The other end of the thermostat heater is connected to terminal 5 of the fabric selector switch. The fabric selector is made up of two 750 Ohm resistors and three sets of contacts. Depending which set of contacts are closed, terminal 5 is connected to terminal 4 with 1500 Ohms of resistance, 750 Ohms of resistance or 0 Ohms of resistance. Terminal 4 is connected to line 1 through the second centrifugal switch in the motor. The fabric selector switch allows the dryer to operate at four temperature; High, Medium, Medium/Low or Low. When the fabric selector switch is set to High, the contacts in the switch are open preventing current from flowing through the thermostat heater. The only heat being applied to the control thermostat is from the blower housing and the dryer operates at the highest temperature. When the fabric switch is set to Medium, the top set of contacts in the switch are closed connecting the thermostat heater in series with the two 750 Ohm resistors to line 1. The control thermostat is then cycled by a combination of heat from the thermostat heater and heat in the drum, lowering the temperature in the drum. When the fabric selector switch is set to Medium/Low, the middle set of contacts are closed connecting the thermostat heater in series with one 750 ohm resistor to line 1. This increases the amount of heat from the thermostat heater and lowers the temperature in the drum. When the fabric selector switch is set to Low, the lower set of contacts in the switch are closed connecting the thermostat heater to line 1. Without the resistors in the circuit, more current flows through the thermostat heater in the Low setting and the control thermostat cycles at a lower drum temperature.

The high limit thermostat is a safety device that prevents the dryer from overheating if the contacts of the control thermostat fail closed. The contacts of the high limit thermostat, normally closed, are set to open at a temperature above the cycling temperature of the control thermostat. From the output terminal of the high limit thermostat, line 2 is connected to one side of the element. The other side of the element is connected to line 1 through the contacts of the second centrifugal switch in the drive motor. This switch prevents power from being applied to the element if the motor is not running.

## The Cycle Signal Circuit:

The cycle signal circuit is made up of the cycle signal (buzzer). When contacts B to C or contacts B to S of the timer are closed and the extra care switch is set to ON, line 2 is connected to one side of the cycle signal. The other side of the cycle signal is connected to terminal H of the timer. A Pulsar cam, located next to the cycle signal cam and rotating at 12 revolutions per hour, allows contacts H to X to close for 5 seconds +/- 3 seconds. Terminal X is connected to neutral through the centrifugal switch in the drive motor.

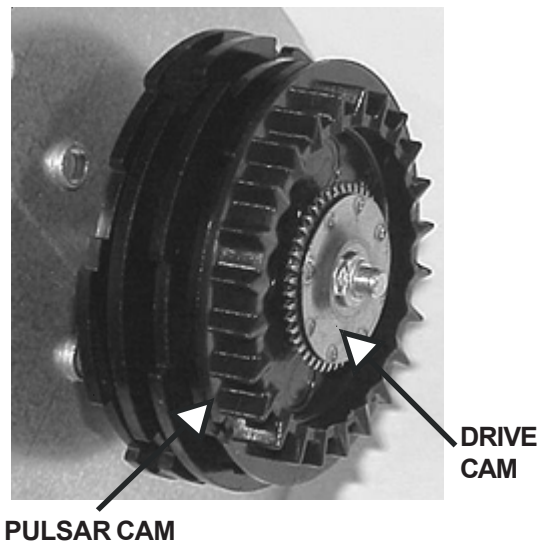

## Timed Dry Cycle

### The Timer Motor Circuit:

When the timed dry cycle is selected, a drying time of up to 90 minutes may be set by turning the timer dial. When the cycle is started, contacts TM to X are closed connecting the timer motor to neutral through the drive motor centrifugal switch. The timer motor runs continuously for the time set. At the end of the cycle the end of cycle signal will sound one or two times.

## Drive Motor and Heating Circuits:

The drive motor and heat circuits operate the same as in the Automatic Dry Cycle.

## Air Fluff Cycle

### The Timer Motor Circuit:

When the air fluff cycle is selected, a drying time of up to 22.5 minutes may be set by turning the timer dial. When the cycle is started, contacts TM to X are closed connecting the timer motor to neutral through the drive

motor centrifugal switch. The timer motor runs continuously for the time set. At the end of the cycle, the end of cycle signal will sound one or two times.

### Drive Motor:

The drive motor circuit operate the same as in the Auto Dry Cycle.

### Heating Circuit:

In Air Fluff, contacts B to A in the timer are open and the dryer operates without heat.

## Electrical Operation: (Gas Dryer)

**Note:** Always refer to the wiring diagram or schematic with the product.

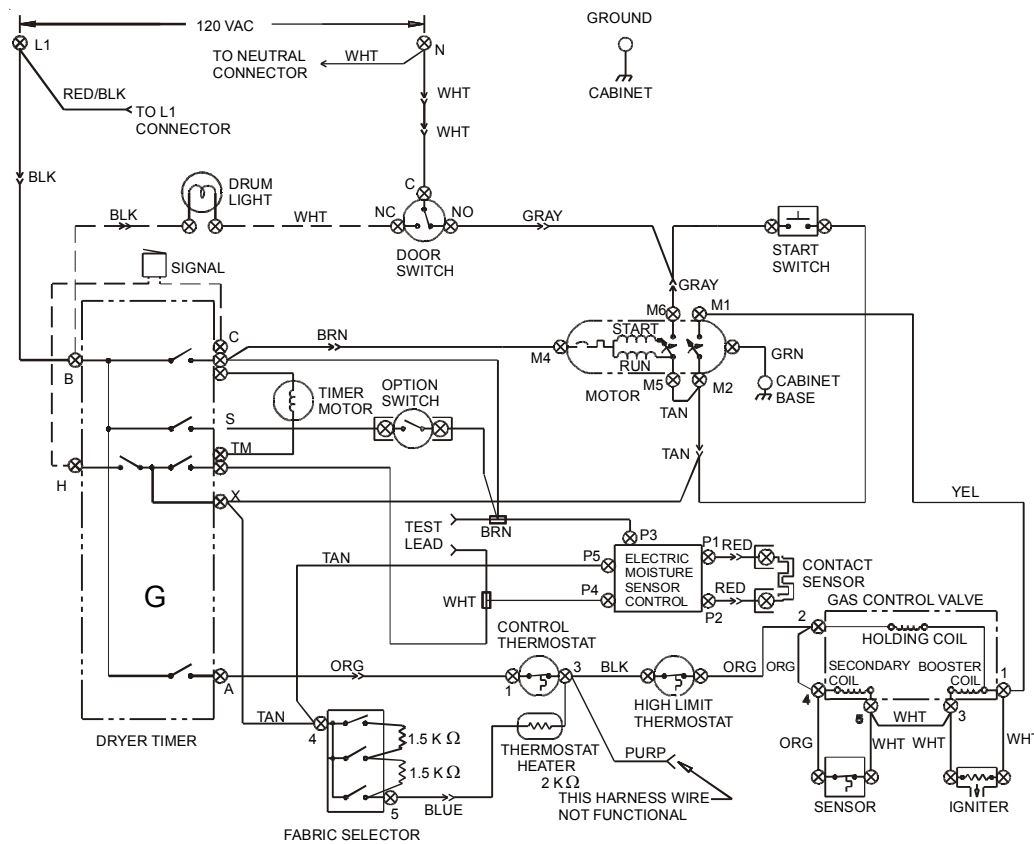

## Auto Dry Cycle

When the dryer is connected to electrical power, line 1 is connected to terminal B of the timer and the input terminal of the signal switch. When the timer is set to the Auto Dry cycle, contacts B to C and B to A are closed. This provides power at the start of the cycle to four circuits; the drive motor circuit, timer motor circuit, electronic moisture sensor control circuit and the heating circuit.

### Drive Motor Circuit:

When contacts B to C are closed line, 1 is applied to terminal M4 of the drive motor. Terminal M4 is connected in the motor to one side of the thermal overload (The thermal overload protects the motor from being damaged by overheating). The other side of the thermal overload is connected to both the run winding and the start winding of the drive motor. When the motor is not turning, the other end of the start winding is connected internally to

terminal M5 of the motor through the NC contact of the motor centrifugal switch. The other end of the run winding is also connected internally to terminal M5.

When the motor is not turning, the start winding and the run winding are connected in parallel. Terminal M5 of the motor is connected to the start switch which is connected to neutral through the door switch. When the start switch is activated, with the dryer door closed, line 1 to neutral voltage is applied across both the start and run windings of the drive motor. With power applied to both the start and run windings, the motor starts to turn. When the speed of the motor reaches about 80% of its normal run speed the contacts of the centrifugal switch change from NC to NO, opening the circuit to the start winding and connecting the run winding to motor terminal M6. Terminal M6 is connected to neutral through the door switch. The Start winding is now out of the circuit. Since the run winding circuit is bypassing the start switch, the switch can be released without interrupting power to the run winding.

The drive motor performs two tasks in the dryer. A pulley attached to one end of the motor shaft uses a belt to drive the dryer drum. The blower wheel is attached to the other end of the motor shaft that pulls the air through the clothes and forces it out the exhaust vent.

### The Timer Motor Circuit:

When timer contacts B to C close, line 1 is applied to one side of the timer motor. The other side of the timer motor is connected to terminal TM of the timer. Terminal TM is connected to neutral through terminals P4 and P5 of the electronic moisture control, the push to start switch (when the motor is not running) and through the centrifugal switch in the motor (when the motor is running). Current flow through the timer motor in the auto dry cycle is controlled by the electronic moisture sensor control. The control circuit in the electronic moisture sensor control is in series with the timer motor. The electronic moisture sensor control measures the capacitance between the two sensor bars located in the vent cover.

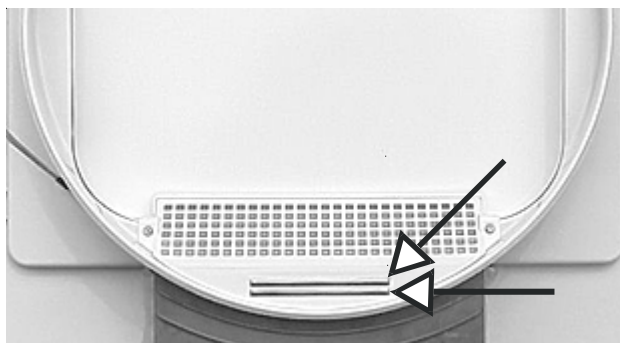

When wet clothes are placed in the dryer, the clothes

touch the sensor bars and the moisture lowers the capacitance between them. The electronic moisture sensor control reads this and increases the resistance between terminals P4 and P5. When resistance is increased in a series circuit, current flow in the circuit is reduced. The increase in resistance inside the control lowers the current flow through the timer motor below the level needed to operate the motor preventing the timer from advancing. As the moisture is removed from the clothes, the capacitance between the bars increases. When the increase in capacitance satisfies the electronic moisture control, the electronic moisture control removes the resistance between terminals P4 and P5, increasing the current flow through the timer motor causing the motor to advance.

### Automatic Press Saver Option

If the Press Saver switch is turned ON at the end of the auto cycle, the timer will advance through the Off position and add 15 minutes to the cycle. During that 15 minutes, contacts B to A in the timer are open and the dryer operates without heat. The end of cycle signal will sound every 5 minutes.

**Note:** In the auto regular cycle, the timer motor can run for 58.75 minutes. The cycle time will be 58.75 minutes plus the timer motor current flow is being shunted by the electronic moisture sensor control.

### The Heat Circuit:

Timer contacts B to A connect line 1 to terminal 1 of the control thermostat. The control thermostat senses the temperature of the air in the blower housing and heat, if any, from the thermostat heater. The control thermostat controls the temperature in the dryer by opening and closing the heater circuit. When the temperature in the drum is below the cycle temperature, contacts 1 and 3 of the thermostat are closed, connecting line 1 to the thermostat heater and the high limit thermostat. The other end of the thermostat heater is connected to terminal 5 of the fabric selector switch. The fabric selector is made up of two 750 Ohm resistors and three sets of contacts. Depending which set of contacts are closed, terminal 5 is connected to terminal 4 with 1500 Ohms of resistance, 750 Ohms of resistance or 0 Ohms of resistance. Terminal 4 is connected to neutral through the centrifugal switch in the motor. The fabric selector switch allows the dryer to operate at four temperature; High, Medium, Medium/Low or Low. When the fabric selector switch is set to High, the contacts in the switch are open preventing current from flowing through the thermostat heater. The only heat being applied to the control thermostat is from the blower housing and the dryer operates at the highest temperature. When the fabric switch is set to



Medium, the top set of contacts in the switch are closed connecting the thermostat heater in series with the two 750 Ohm resistors to neutral. The control thermostat is then cycled by a combination of heat from the thermostat heater and heat in the blower housing, lowering the temperature in the drum. When the fabric selector switch is set to Medium/Low, the middle set of contacts are closed connecting the thermostat heater in series with one 750 ohm resistor to neutral. This increases the amount of heat from the thermostat heater and lowers the temperature in the drum. When the fabric selector switch is set to Low, the lower set of contacts in the switch are closed connecting the thermostat heater to neutral. Without the resistors in the circuit, more current flows through the thermostat heater in the Low setting and the control thermostat cycles at a lower drum temperature.

The high limit thermostat is a safety device that prevents the dryer from overheating if the contacts of the control thermostat fail closed. The contacts of the high limit thermostat, normally closed, are set to open at a temperature above the cycling temperature of the control thermostat. From the output terminal of the high limit thermostat, line 1 is connected to one side of the holding coil of the gas valve, the secondary coil of the gas valve and the sensor that is mounted on the burner chamber.

The holding coil, secondary coil, booster coil, sensor and igniter circuits interact with one another to assure safe operation of the dryer gas burner.

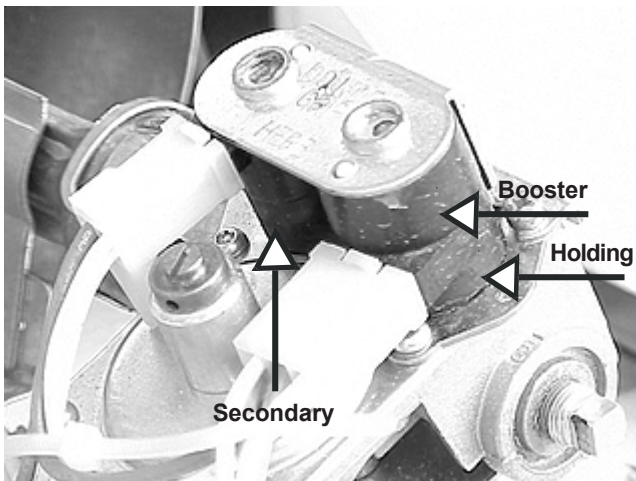

The gas valve has two chambers in series; both must be opened before gas will flow into the burner. The solenoid that controls the gas flow through the first chamber has two coils: the booster coil and the holding coil. The solenoid that controls the second chamber has one coil, the secondary coil.

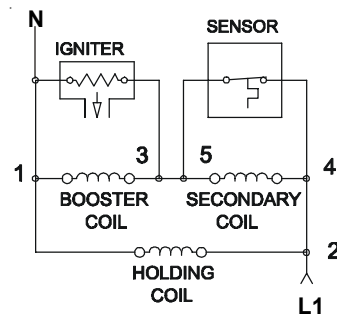

The other side of the holding coil, booster coil and igniter are connected to neutral through the two centrifugal switches in the motor (closed when the motor is running) and the door switch. When power is applied across these circuits, current flows through the holding coil but the holding coil does not have enough magnetic force to open the solenoid by itself. At the same time, current flows through sensor contacts providing power to the booster coil and the igniter. When current flows through both the holding and booster coils, the first chamber opens. The contacts of the sensor are in parallel with the secondary coil, so as long as the contacts of the sensor remain closed, current flow bypasses the secondary coil, and gas is prevented from flowing through the second chamber of the valve to the burner.

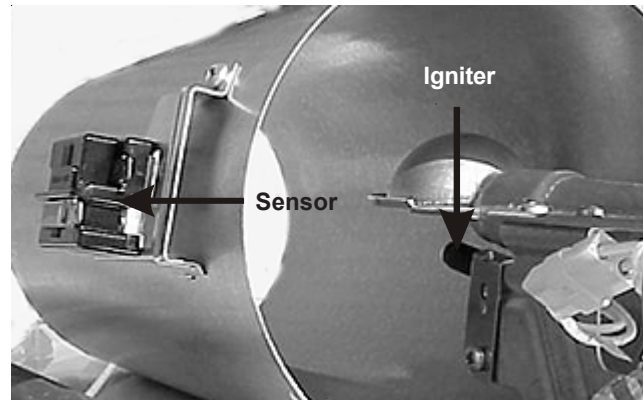

It is necessary to raise the temperature above 1100° F to ignite gas. As current flows through the igniter, the temperature of igniter raises from room temperature to about 1800° F within 30 seconds. The contacts of the sensor are heat sensitive and set to open above the ignition temperature of gas. When the sensor contacts open, current flows through the secondary coil opening the second chamber, allowing gas to the burner, which is ignited by the heat of the igniter. When the contacts of the sensor are open, the parallel circuit formed by the igniter and the booster coil are in series with the secondary coil which lowers the current flow through the igniter and booster coil. Since it takes less magnetic force to hold a solenoid open than it does to open it, the first solenoid remains open when the current through the booster coil is reduced. The reduction of current flow through the igniter reduces heat from the igniter but the sensor contacts are held open by the heat of the burner flame.

### The Cycle Signal Circuit:

The cycle signal circuit is made up of the cycle signal (buzzer). When contacts B to C or contacts B to S of the timer are closed and the extra care switch is set to ON, line 2 is connected to one side of the cycle signal. The other side of the cycle signal is connected to terminal H of the timer. A Pulsar cam, located next to the cycle signal cam and rotating at 12 revolutions per hour, allows contacts H to X to close for 5 seconds +/- 3 seconds. Terminal X is connected to neutral through the centrifugal switch in the drive motor.

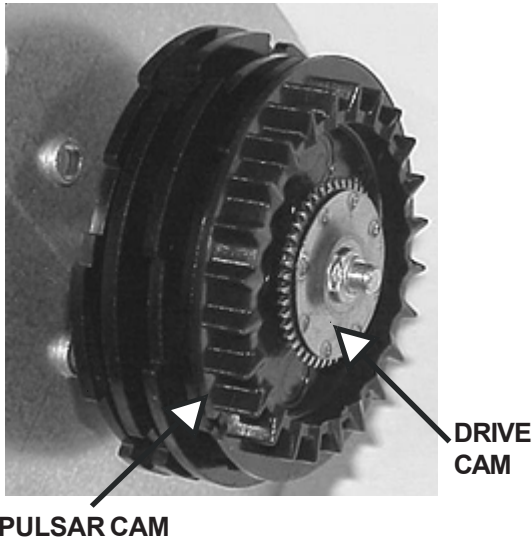

### Timed Dry Cycle

#### The Timer Motor Circuit:

When the timed dry cycle is selected, a drying time of up to 90 minutes may be set by turning the timer dial. When the cycle is started, contacts TM to X are closed connecting the timer motor to neutral through the drive motor centrifugal switch. The timer motor runs continuously for the time set. At the end of the cycle, the end of cycle signal will sound one or two times.

#### Drive Motor and Heating Circuits:

The drive motor and heat circuits operate the same as in the Automatic Dry Cycle.

### Air Fluff Cycle

#### The Timer Motor Circuit:

When the air fluff cycle is selected, a drying time of up to 22.5 minutes may be set by turning the timer dial. When the cycle is started, contacts TM to X are closed connecting the timer motor to neutral through the drive motor centrifugal switch. The timer motor runs continu-

ously for the time set. At the end of the cycle, the end of cycle signal will sound one or two times.

#### Drive Motor:

The drive motor circuit operate the same as in the Automatic Dry Cycle.

#### Heating Circuit:

In Air Fluff, contacts B to A in the timer are open and the dryer operates without heat.

## SECTION F - WASHER SECTION OPERATION

### Timer:

The timer is located behind the control panel and controls electrical power to the components of the washer.

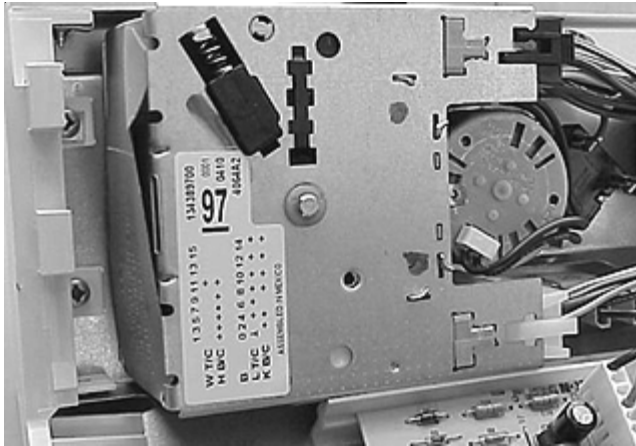

The timer is made up of a motor driven spool that advances one increment a minute whenever electrical power is applied to the motor.

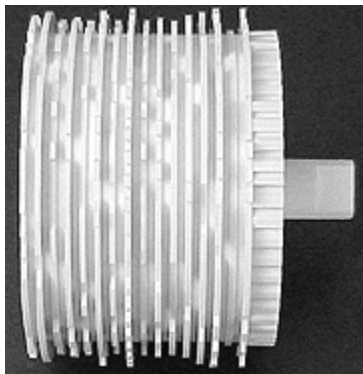

The spool has 14 cams that open and close the 24 contacts which supply electric power to components at the correct time in the cycles.

To help determine when each set of contacts are closed, a timer cycle chart is provided with each washer (A sample timer cycle chart is shown on the following page.) The first column of the chart is titled CAM. In this column are numbers 0 to 14 that equate to the number of cams starting at the rear of the timer. The next two columns are titled TERM for terminals and are identified as ACTIVE and FIXED. The active terminals are the terminals that are moved by the cams. The fixed terminals are the ones that do not move. The active terminals are usually the terminals that have power applied to them with the fixed terminals connected to the components that power

is being applied to. The next column is titled CONTACT and identified as T for the top contacts of the fixed terminals and B for the bottom contacts of the fixed terminals. The next column is titled CIRCUIT and indicates the circuit controlled by the cam, terminals and contacts. For example, CAM 14, ACTIVE terminal 19, FIXED terminal 24, and CONTACT B controls the drain pump circuit at specific times. Each circuit has a horizontal line extending across the timer chart. The remaining columns make up the wash cycles and are connected by vertical lines below to the step time in minutes and the step number. When the boxes formed by the horizontal lines from the circuit and the vertical lines step time are filled in, this indicates that electrical power is applied to that circuit at that time in the cycle.

**IMPORTANT NOTE:** Only the cam numbers are called out on the schematic and wiring diagram.

### Line Switch:

The line switch is located inside the timer and controls electrical power to the washer. When the timer knob is pulled out, the switch contacts are closed. When the timer knob is pushed in or the timer is advanced to the end of the cycle, the contacts are opened.

### Dispenser Drawer Reed Switch:

The dispenser drawer reed switch is a safety switch that prevents the washer from operating when the dispenser drawer is open. The switch, located behind the control panel next to the dispenser drawer, controls electrical power to the door lock coil and the door lamp.

It's contacts are controlled by the magnetic field of the magnet located in the in the front panel of the dispenser drawer.

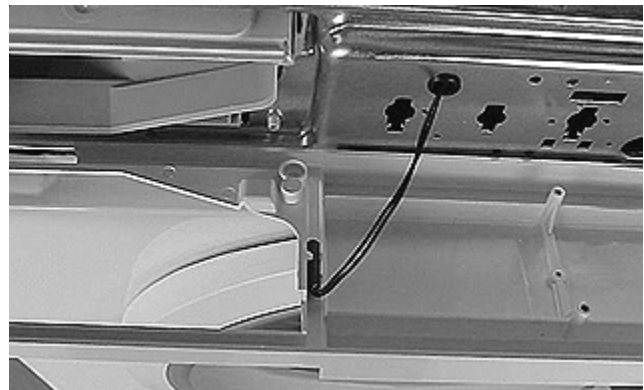

C A M	TERM.		C O N T A C T	CIRCUIT	REGULAR																		
	A F I N D	F I X T E R M I N E			WASH			RINSE AND SPIN							FINAL SPIN								
	V D E	D E C T			H E A V Y	M E D	L I G H T																
0/0			T	DETENT																			
0	2	1	T	MACHINE POWER																			
1	23	22	T																				
		24	B	CODE A																			
2	5	4	T																				
		6	B	SOLENOID 2																			
3	23	19	T																				
		21	B	CODE B																			
4	5	7	T	CODE E																			
		9	B	SOLENOID 1																			
5	23	16	T																				
		18	B	CODE C																			
6	11	10	T	TM DIRECT																			
			B																				
7	23	13	T																				
		15	B	CODE D																			
8	14	17	T	WASH WATER MAIN																			
		15	B	RINSE WATER MAIN																			
9	23	10	T																				
		12	B	WASH LAMP																			
10	17	16	T	RINSE WATER TEMP																			
		18	B	WASH WATER TEMP																			
11	23	7	T	RINSE LAMP																			
		9	B	FINAL SPIN LAMP																			
12	20	19	T	PRESS SW. BYPASS																			
		21	B	BUZZER																			
14	19	22	T	DRAIN PUMP - EX RINSE																			
		24	B	DRAIN PUMP																			
					STEP TIME (MIN)	3	2	6	6	1	2	3	2	3	1	2	3	2	8	2			
						.0	.0	.7	.0	.0	.0	.0	.5	.0	.0	.0	.0	.0	.1	.6			
					STEP NO.	1				5					10						15		

**Sample timer cycle chart (partial)**

power to the door lock coil and door lamp. When the drawer is open, the contacts of the reed switch are open preventing the door switch from closing.

**Door Switch Assembly:**

The door switch assembly, located behind the front panel, is a safety feature that prevents the washer from operating when the door is open and also locks the door in the spin cycle. The door lock assembly is made up of a coil, door switch, switch actuator, locking fork, wax motor, and spin lock arm. When the timer line switch is closed, electrical power is applied to the coil and the door lock switch. The magnet field of the coil pulls the locking fork down and tries to pull the contacts of the door lock switch closed. If the washer door is open, a tab on the switch actuator prevents the contacts from closing.

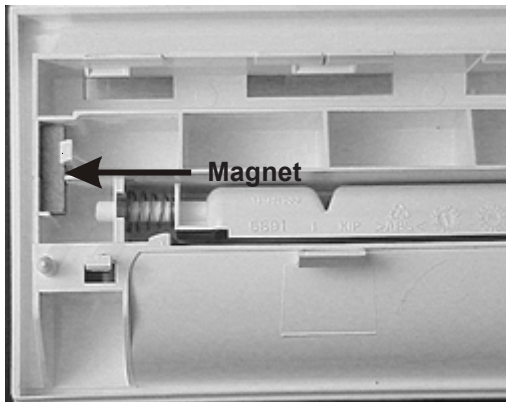

When the drawer is closed, the magnet causes the contacts of the reed switch to close providing electrical



The locking fork will not allow the door to be closed until the timer line switch is opened. When the washer door is closed, the door strike pivots the switch actuator out of the way allowing the magnetic field of the coil to close the contacts of the door lock switch and the locking fork locks the door. The wax motor and spin lock arm are used to prevent the door from being opened while the spin basket is still spinning. The wax motor is electrically in parallel with the drain pump. Power is applied to the wax motor when the washer is in spin. When power is applied to the wax motor, it expands its piston within 30 to 40 seconds, driving the spin lock arm between the locking fork and the switch actuator thus holding the locking fork down. When power is removed from the wax motor, it takes about 90 seconds for the wax motor to cool down and retract the piston, pulling the spin lock arm back away from the locking fork. This provides enough time for the spin basket to slow its rotation down to the wash speed before the door could possibly be opened.

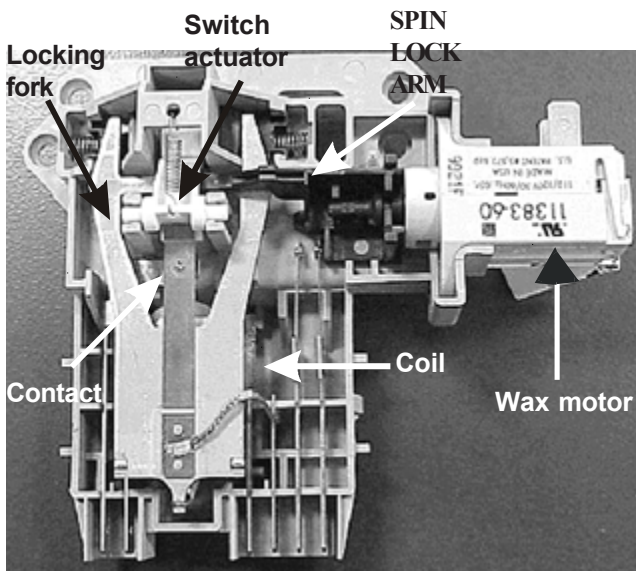

**Pressure Switch:**

The pressure switch, mounted to the control mounting bracket under the washer top, controls the water level in the washer. The pressure switch is made up of a single pole double throw switch that is controlled by a bellow which covers a sealed chamber. The pressure switch is connected by a hose to an air bell located at the bottom of the washer which is attached to the drain boot. Electrical power is applied to the pressure switch whenever the contacts of the door switch are closed. If the water level is below 1.2 inches from the bottom of the spin basket, contacts 1 to 2 of the pressure switch close applying power to the active terminal of cam 8 of the timer. When the timer advances to the fill increment, water enters the tub.



As the tub begin to fill, air trapped in the air bell and hose is compressed increasing the air pressure against the bellow. When the water level reaches about 2 1/2 inches from the bottom of the spin basket, the bellow opens contacts 1 to 2 which removes power from the water inlet valves, and closes contacts 1 to 3 providing power to other components.

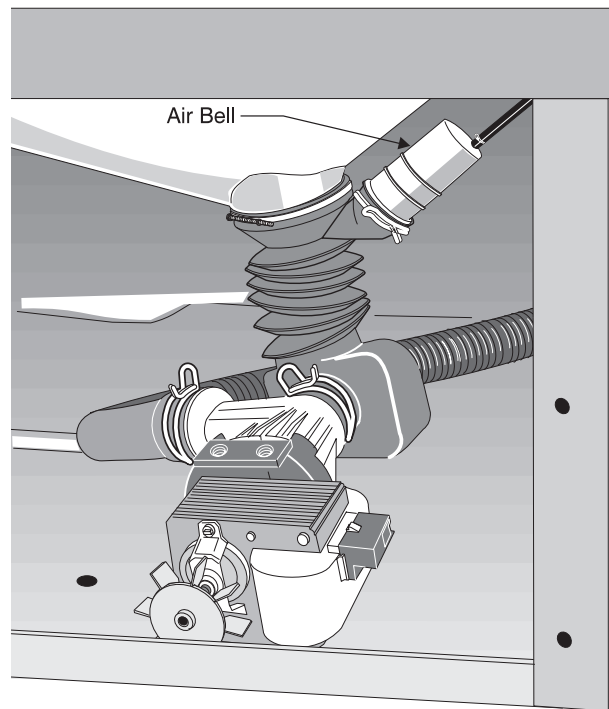

**Automatic Dispenser:**

The automatic dispenser for detergent, liquid bleach and fabric softener system is made up of the dispenser cavity,



and a removable drawer with three cavities, one for detergent, one for bleach and one for fabric softener.

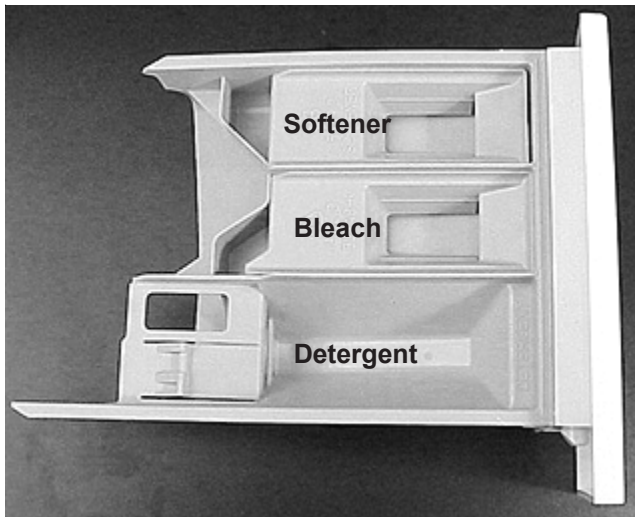

The dispenser cavity is connected to the water inlet valve by a hose.

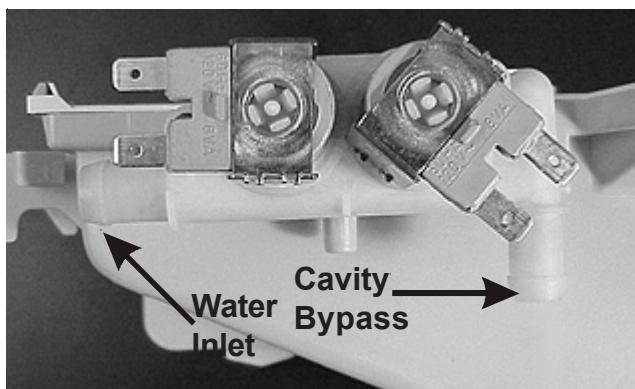

All the water that enters the washer passes through the solenoid valve assembly attached to the rear of the dispenser cavity. The water entering this assembly has four exit paths, two of which depend on input from the timer. The remaining two paths allow water to go through the cavity bypass or into the soap cavity through holes in the top of the dispenser during each fill.

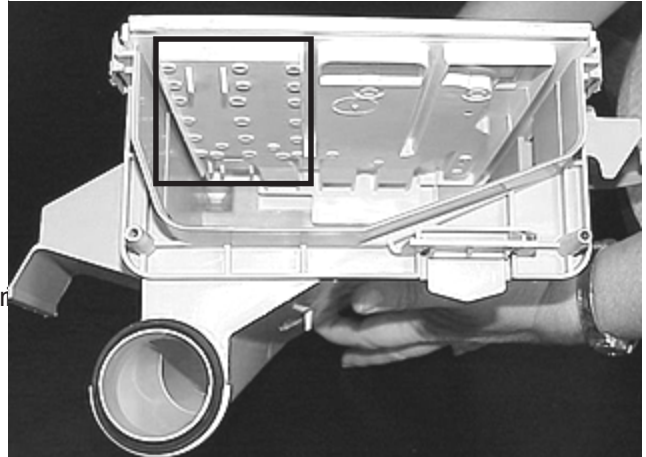

Bleach and fabric softener dispensing is controlled by the timer at specified times in the cycle by using the electrical solenoids and redirecting some of the water fill into their containers. The bleach and the fabric softener cavities have tubes molded into the bottom which allows the cavity to be filled without being immediately dispensed into the washer.

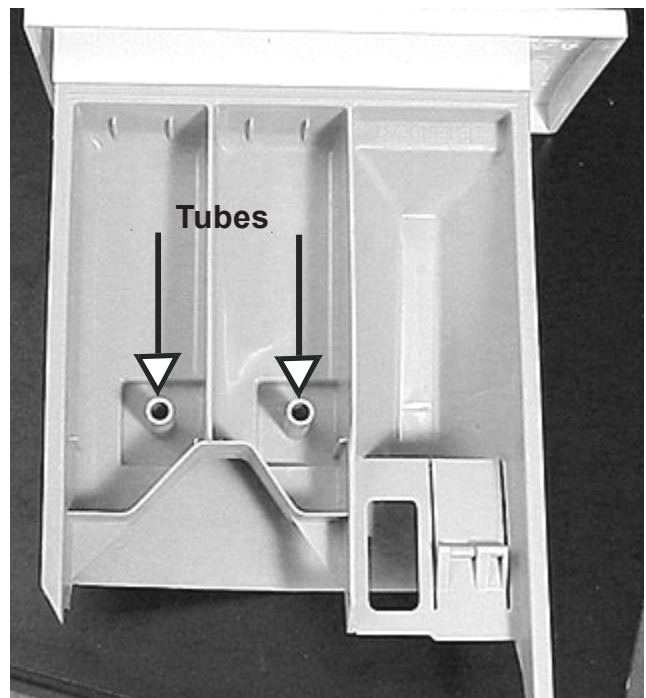

Bleach and fabric softener inserts fit into each respective cavity and have a tube molded onto them. These tubes are larger than the tubes in the cavity and are designed to fit over the tubes, but not touch the bottom of the cavity when the insert is installed. When the correct time comes for the bleach or the fabric softener to enter, the washer timer supplies 120 VAC to the solenoid behind that cavity allowing part of the incoming water to flow into the cavity from above.

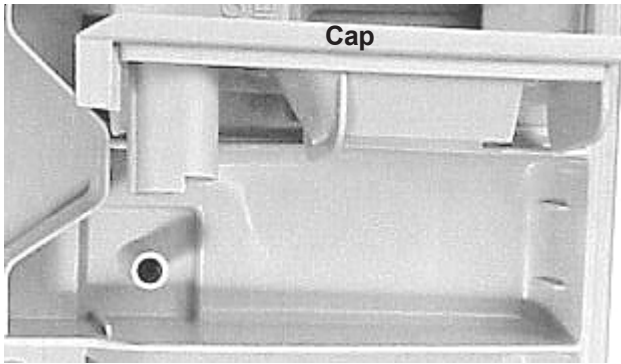

When water is added to either the bleach or fabric softener liquid, the mixture level rises between the two tubes above the tube in the cavity and flows into the washer tub. Since the end of the tube on the insert does not touch the bottom of the cavity, a siphoning action will start when the solenoid activates and allows water into the cavity. The added water creates an “overflow” condition and starts the siphoning. The cavity will empty itself when the water is turned off by the solenoid.

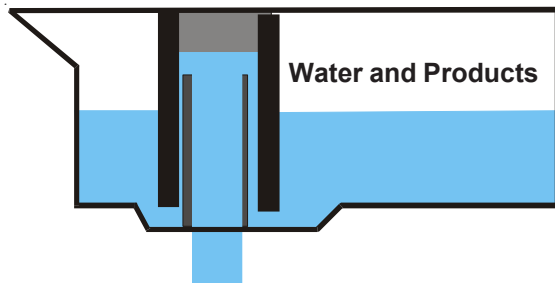

**Temperature Switch:**

The temperature switch, mounted behind the control panel, controls the water temperature in the wash and rinse cycles by supplying power to the water valve.

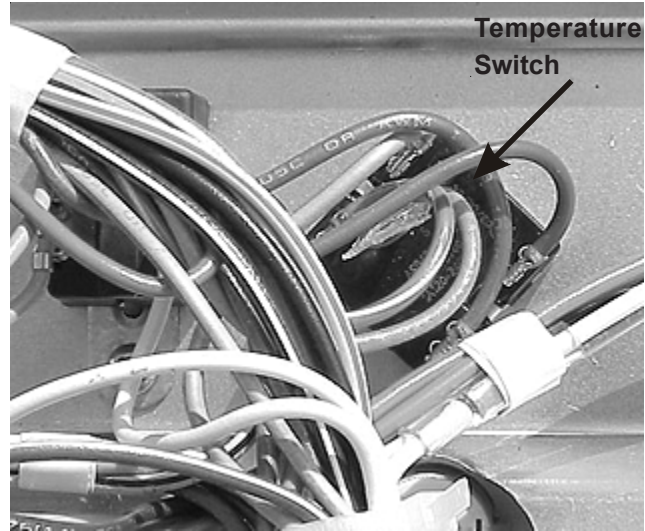

The switch has 3 input terminals that receive power from the timer. Two output terminals (on models without the auto temp feature) are connected to the hot and cold solenoids of the water valve.

**Water Inlet Valve:**

The water valve, located in the lefthand corner of the washer section, is mounted to the rear reinforcement bracket.

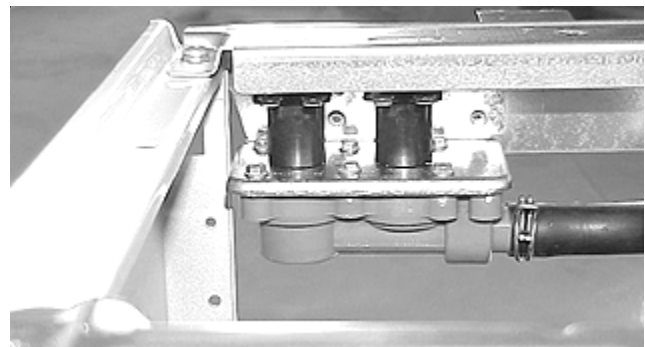

The water inlet valve is actually two solenoid operating valves in one body. A hot water valve and a cold water valve discharge into a common mixing chamber. The flow of water out of the chamber is controlled by a molded in flow washer capable of maintaining a flow rate of 3.0 - 14.6 gallons per minute, with incoming water pressure of 30 to 120 P.S.I. The inlet valve is controlled by the timer and water temperature selector switch, individually or together, to provide hot, cold, or warm water for washing and cold or warm water for rinsing. The temperature of the warm mixture will be dependent upon the temperature and pressure of the hot and cold water supply lines.



## Valve Operation:

Both inlet solenoid valves are identical in construction and operation. The valve body provides an air passage with a large orifice and seat where the water can be stopped. The outlet of the valve body empties into the mixing chamber. A moveable rubber diaphragm operates against the valve seat to start and stop the flow of water. The diaphragm is operated by water pressure. It has a small bleed orifice outside the seat contact area, and a large main orifice at its center. The armature of the solenoid serves to open and close the main orifice. The armature operates within a closed metal tube (valve guide) which is sealed by the outer edge of the diaphragm to the valve body. A coil spring holds the armature down against the diaphragm main orifice when the solenoid is not energized.

The following line drawings and text explains basic valve operation.

When the valve is in a closed position, the solenoid is not energized. Water has bled through the diaphragm bleed orifice placing incoming line pressure on top of the diaphragm. The bottom of the diaphragm is essentially at atmospheric pressure (open to the outlet) and the pressure differential holds the valve shut.

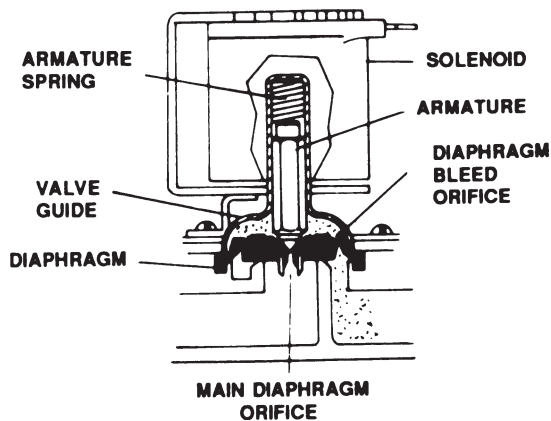

**Water Valve Closed**

When the solenoid is energized, the resulting magnetic field pulls the armature up into the valve guide. The armature spring is compressed by this action. When the armature moves up, it allows the water on the top of the diaphragm to drain through the main orifice.

The diaphragm bleed orifice is much smaller than the main orifice and will not admit enough water to maintain pressure on the top side of the diaphragm. Thus, as the pressure on the top of the diaphragm is reduced to almost zero, the pressure on the bottom lifts the diaphragm off the valve seat, allowing a full flow of water.

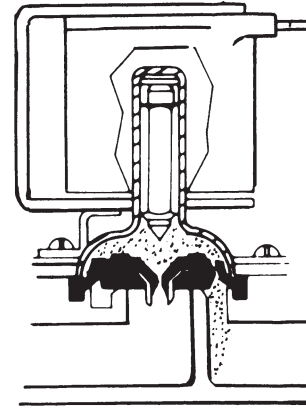

**Solenoid Activated**

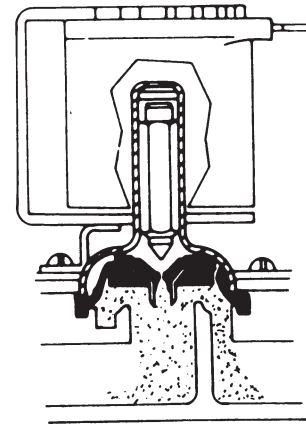

**Water Valve Open and Diaphragm Up**

When the solenoid is de-energized, the armature drops down, closing the diaphragm main orifice. Water continues to flow through the diaphragm bleed orifice, equalizing the pressure and allowing the spring to push the diaphragm down against the valve seat.

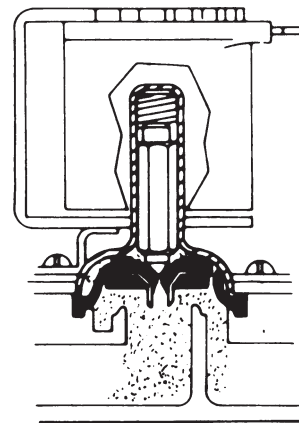

**Water Valve Closing**

### Extra Rinse Switch:

The extra rinse switch is mounted behind the control panel.

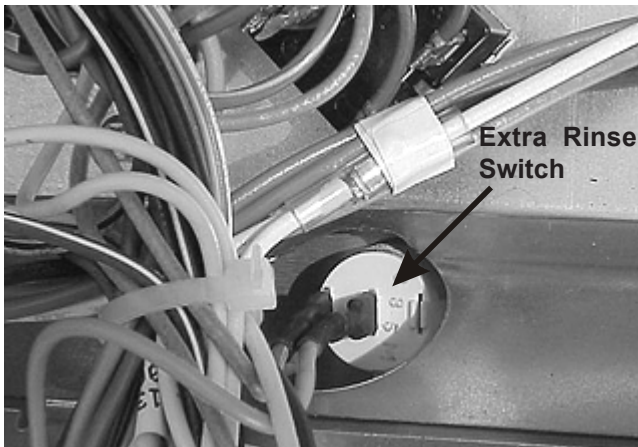

The extra rinse switch provides an extra rinse in the regular wash cycle when selected. This is accomplished by energizing the drain pump to remove the water from the wash tub. When enough water is removed from the tub that the pressure switch is no longer satisfied, the pressure switch will reset and energize the fill valve, thus creating an extra rinse.

### Drain Pump:

The drain pump is mounted to the bottom plate of the washer section, in the right front corner, behind the access panel. It operates on 120 VAC and is controlled by the timer. The pump out specifications of the drain pump vary from 12 G.P.M. with a 3 foot standpipe height to 7 G.P.M. with a 8 foot standpipe height.

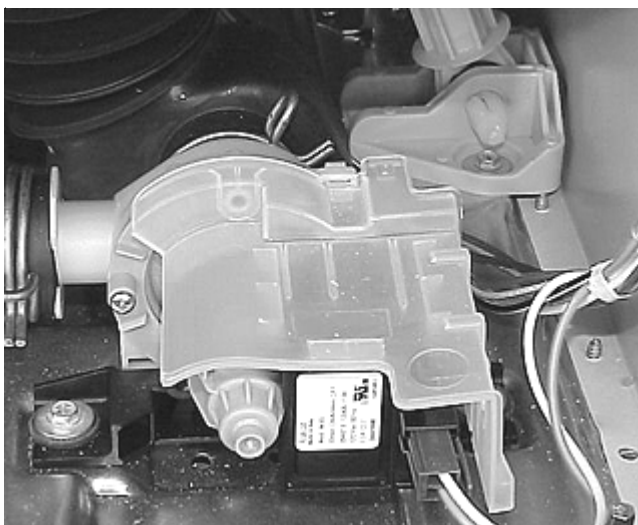

### Speed Control:

The speed control board is mounted to the bottom plate of the washer in the right rear corner of the washer section. The speed control board controls the following operations:

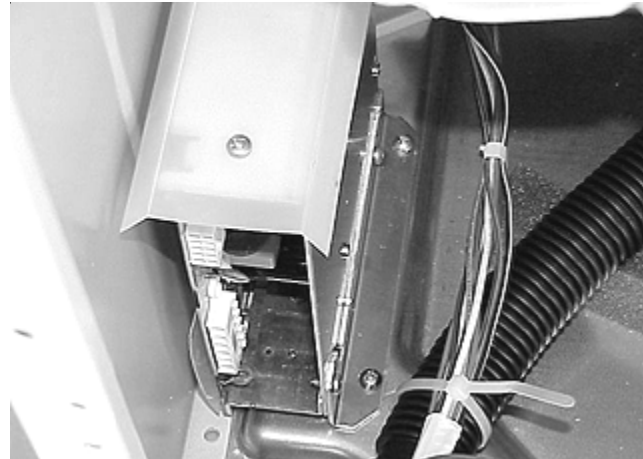

1. Advancement of the increments by connecting and disconnecting neutral to pin 5 of the ten pin plug of the control board.
2. The timing of each function, and the speed and direction of the drive motor. The speed control board has six terminals marked on the schematic as A,B,C,D,E, and F that receive inputs or codes from the control board. These inputs or codes program the speed control board to run the drive motor at a certain speed and for a preset length of time. When the program is complete, the speed control board sends a signal to the control board to advance to the next increment.
3. The speed of the drive motor by converting input line to neutral single phase 60 Hertz voltage, to a varying frequency, three phase output voltage from zero to 300 VAC. By varying the amount, frequency, and polarity of the voltage and comparing the input from the tachogenerator on the drive motor, the speed control board can operate the drive motor at a preprogrammed speed and direction.
4. The balance of the load in the washer during the spin cycle by converting the sine wave from the tachogenerator to square waves and comparing the distance between the square waves.

### Speed Switch:

The speed switch, mounted to the control mounting bracket behind the control panel, controls the speed of the final spin.

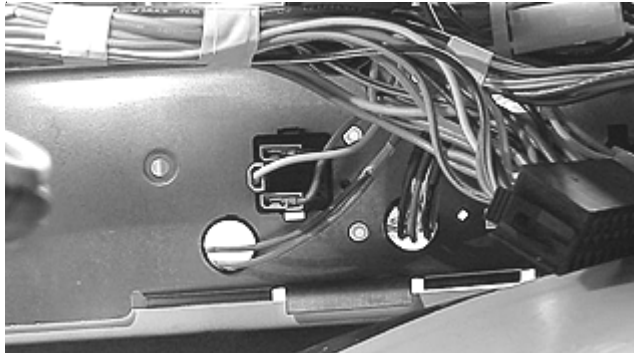

The speed switch is a two terminal single pole, single throw switch.

Speed Switch Two terminals	
Circuit	1 - 2
Normal	Closed
Fast	Open

### Motor:

The motor is mounted to the bottom of the outer tub.



The motor is an induction, three phase AC motor that varies speeds when the voltage from the speed control board varies in frequency and amount. The motor has a tachogenerator that inputs the speed of the motor to the speed control board.

## **SECTION G - TROUBLESHOOTING FLOW CHARTS**

**NOTE: Always check the wiring and pin/plug connectors before replacing any component.**

### **DRYER SECTION:**

<b>Electric dryer; completely inoperative.</b>	<b>Page 70</b>
<b>Gas dryer; completely inoperative.</b>	<b>Page 71</b>
<b>Electric and Gas dryers; timer advances in timed dry but not in auto dry.</b>	<b>Page 72</b>
<b>Electric and Gas dryers; timer does not pause in auto dry with wet clothes in the dryer.</b>	<b>Page 72</b>
<b>Electric and Gas dryers; blower motor runs but drum does not turn.</b>	<b>Page 73</b>
<b>Electric and Gas dryers; longer than normal drying times.</b>	<b>Page 73</b>
<b>Electric dryers; blower motor runs but dryer does not heat.</b>	<b>Page 74</b>
<b>Gas dryers; blower motor runs but dryer does not heat.</b>	<b>Page 75</b>
<b>Electric and Gas dryers; blower motor runs but timer does not advance in auto or timed dry.</b>	<b>Page 76</b>
<b>Electric and Gas dryers; dryer over heating.</b>	<b>Page 76</b>
<b>Electric and Gas dryers; timer advances in auto dry but not in timed dry.</b>	<b>Page 76</b>

**WASHER SECTION:**

<b>Speed control and motor plug and pin layout</b>	<b>Page 77</b>
<b>Washer completely inoperative.</b>	<b>Page 78</b>
<b>Timer does not advance.</b>	<b>Page 78</b>
<b>Washer does not drain.</b>	<b>Page 79</b>
<b>Extra rinse setting does not work.</b>	<b>Page 79</b>
<b>Bleach dispenser does not operate.</b>	<b>Page 80</b>
<b>Softner dispenser does not operate.</b>	<b>Page 80</b>
<b>Drive motor does not turn.</b>	<b>Page 81</b>
<b>Drive motor spins but does not tumble.</b>	<b>Page 82</b>
<b>Drive motor tumbles but does not spin.</b>	<b>Page 82</b>
<b>Drive motor tumbles very slowly in any timer position.</b>	<b>Page 83</b>
<b>Spin cycle operating at incorrect speed for switch setting.</b>	<b>Page 83</b>
<b>Water fill does not turn off.</b>	<b>Page 84</b>
<b>Incorrect water level.</b>	<b>Page 84</b>
<b>Slow water fill.</b>	<b>Page 85</b>
<b>Door indicator lamp does not glow.</b>	<b>Page 85</b>
<b>Washer will not fill in any setting of the temp switch.</b>	<b>Page 86</b>
<b>Water temperature is too hot or too cold in the wash cycle with the temp switch set to warm/warm.</b>	<b>Page 87</b>
<b>Washer will only fill with hot water in the wash cycle, with the temp switch set to warm/cold but does fill with cold in the rinse cycle.</b>	<b>Page 87</b>

**Electric dryer completely inoperative.**  
***Note: Always check wiring to the components.***

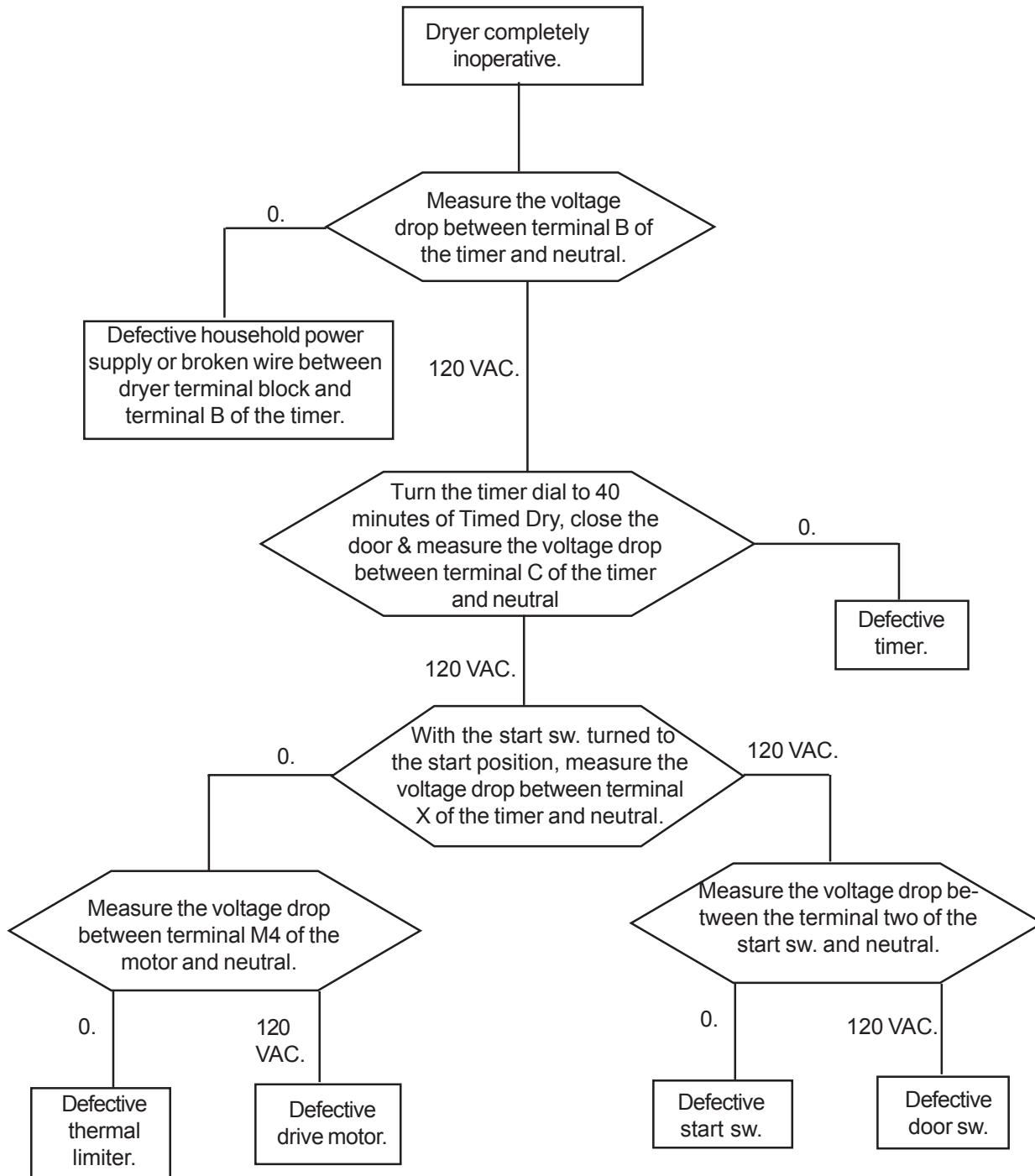



**Gas dryer completely inoperative.**

**Note: Always check wiring to the components.**

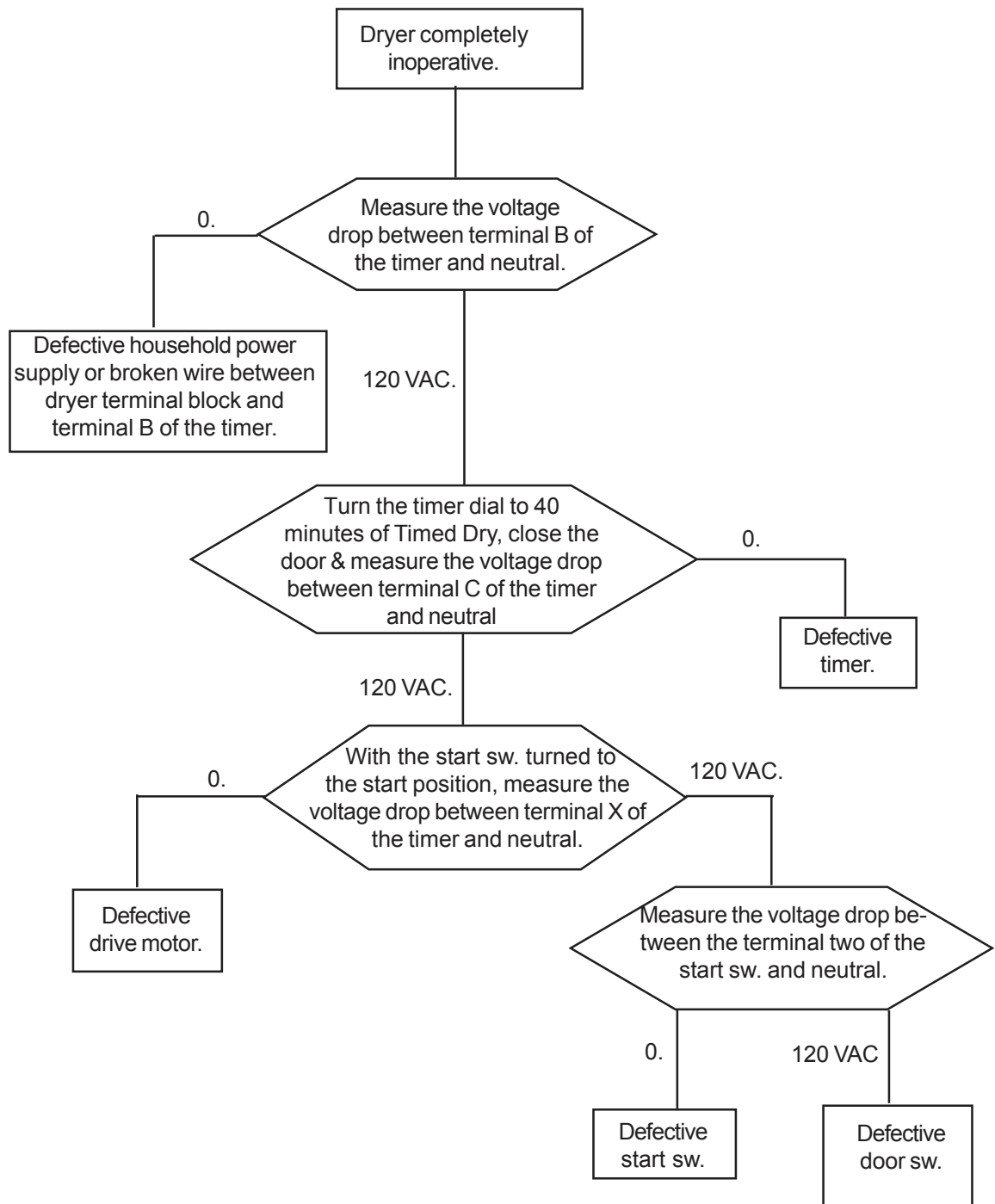

**Electric and Gas dryers; timer advances in Timed Dry but not in Auto Dry.**

**Note: Always check wiring to the components.**

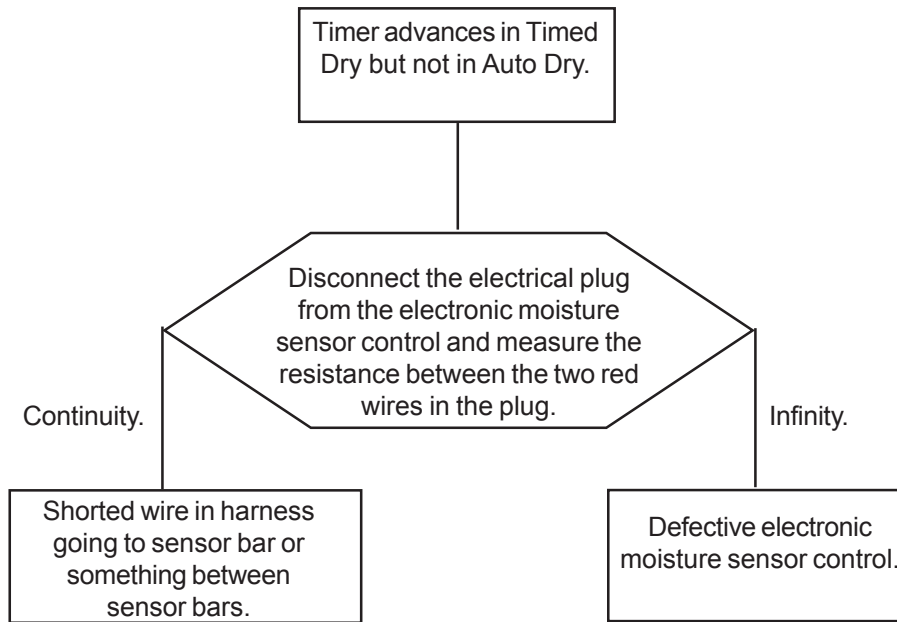

---

**Electric and Gas dryers; timer does not pause in Auto Dry with wet clothes in the dryer.**

**Note: Always check wiring to the components.**

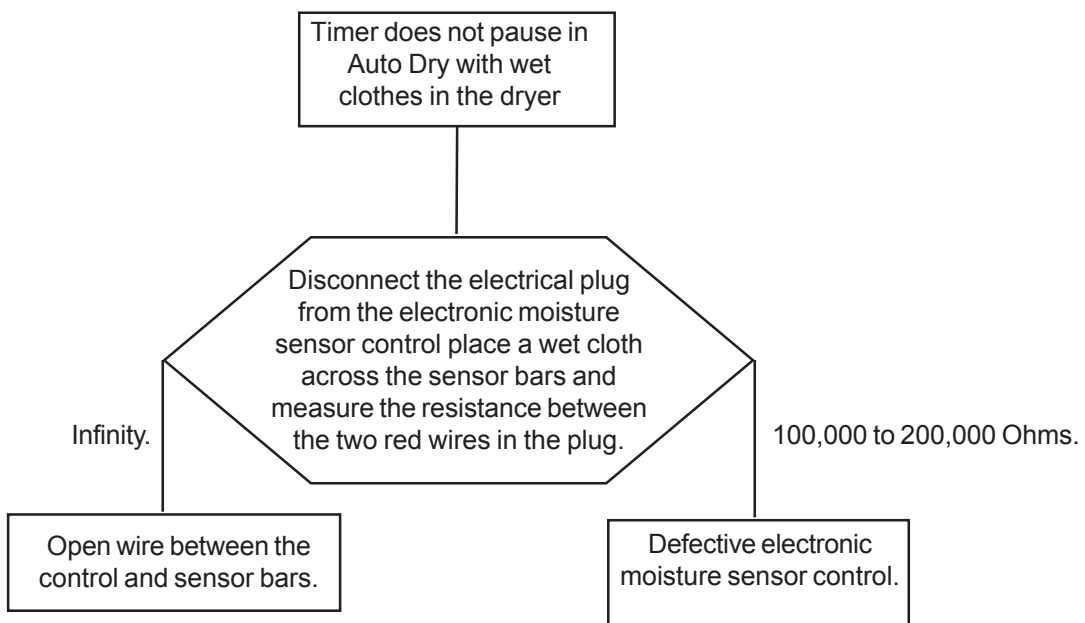

**Electric and Gas dryers; blower motor runs but drum does not turn.**

**Note: Always check wiring to the components.**

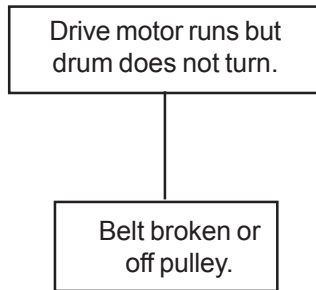

**Electric and Gas dryers; longer than normal drying times.**

**Note: Always check wiring to the components.**

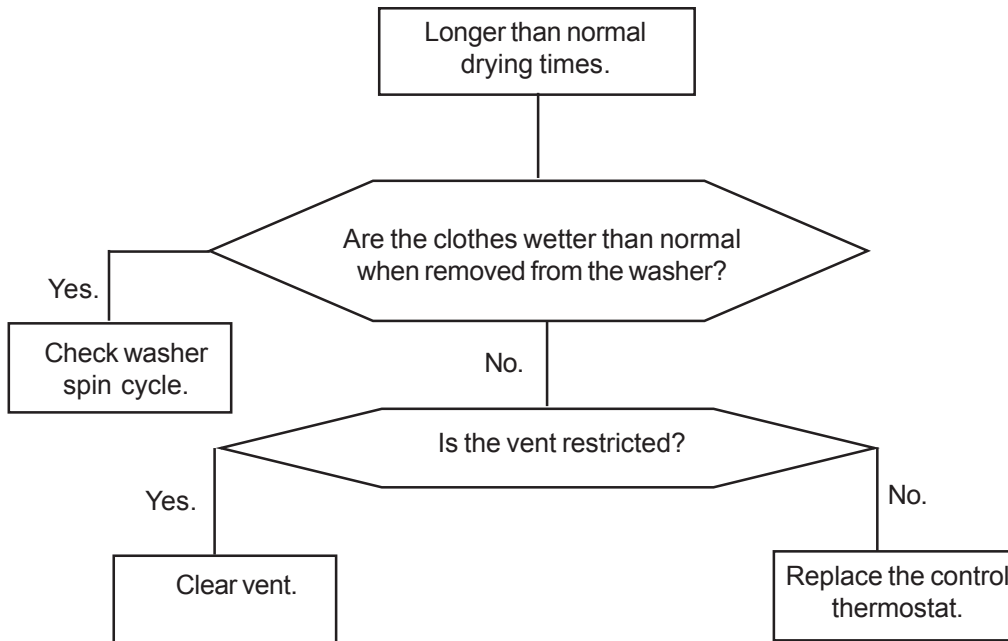

**Electric dryers; blower motor runs but dryer does not heat.**

**Note: Always check wiring to the components.**

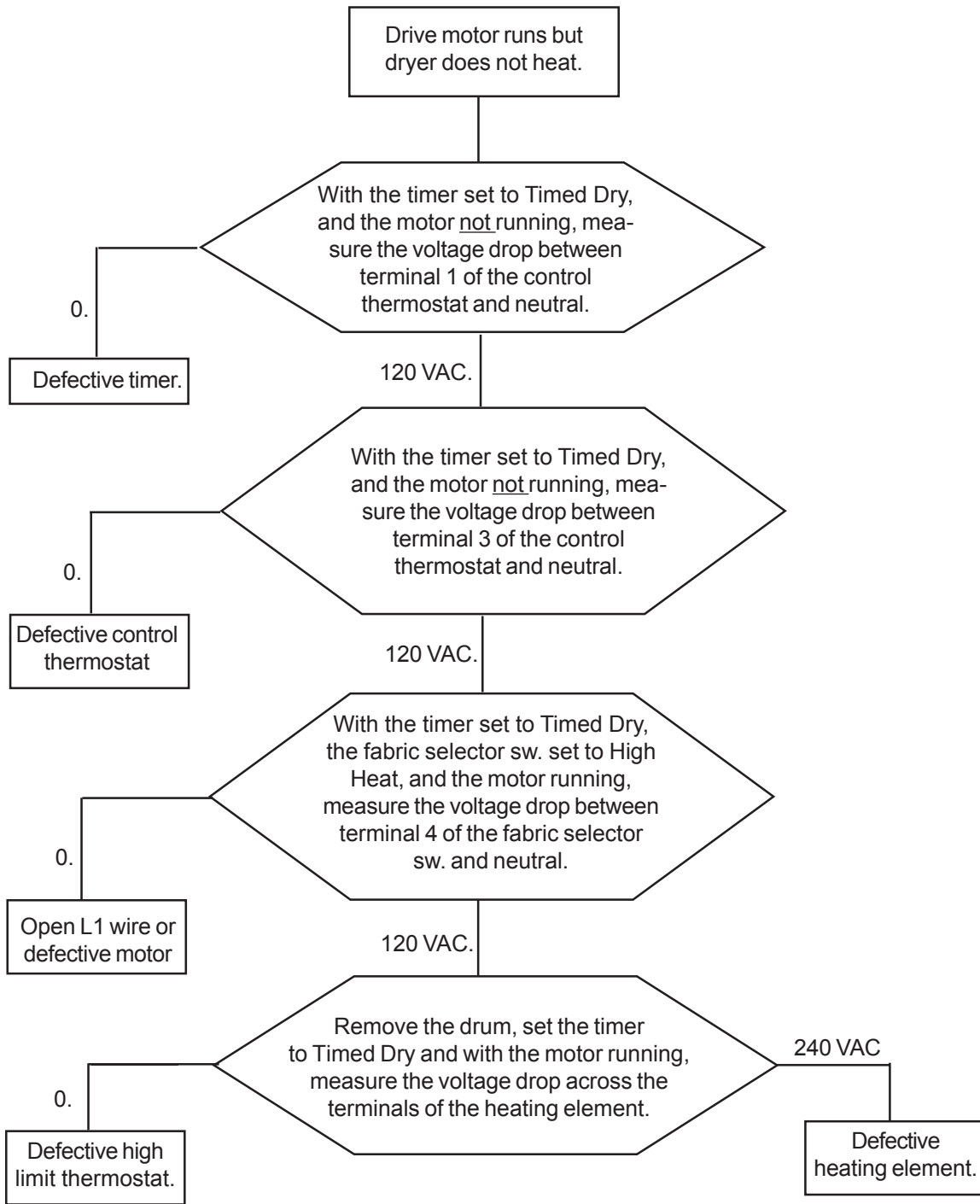

**Gas dryers; blower motor runs but dryer does not heat.**

**Note: Always check wiring to the components.**

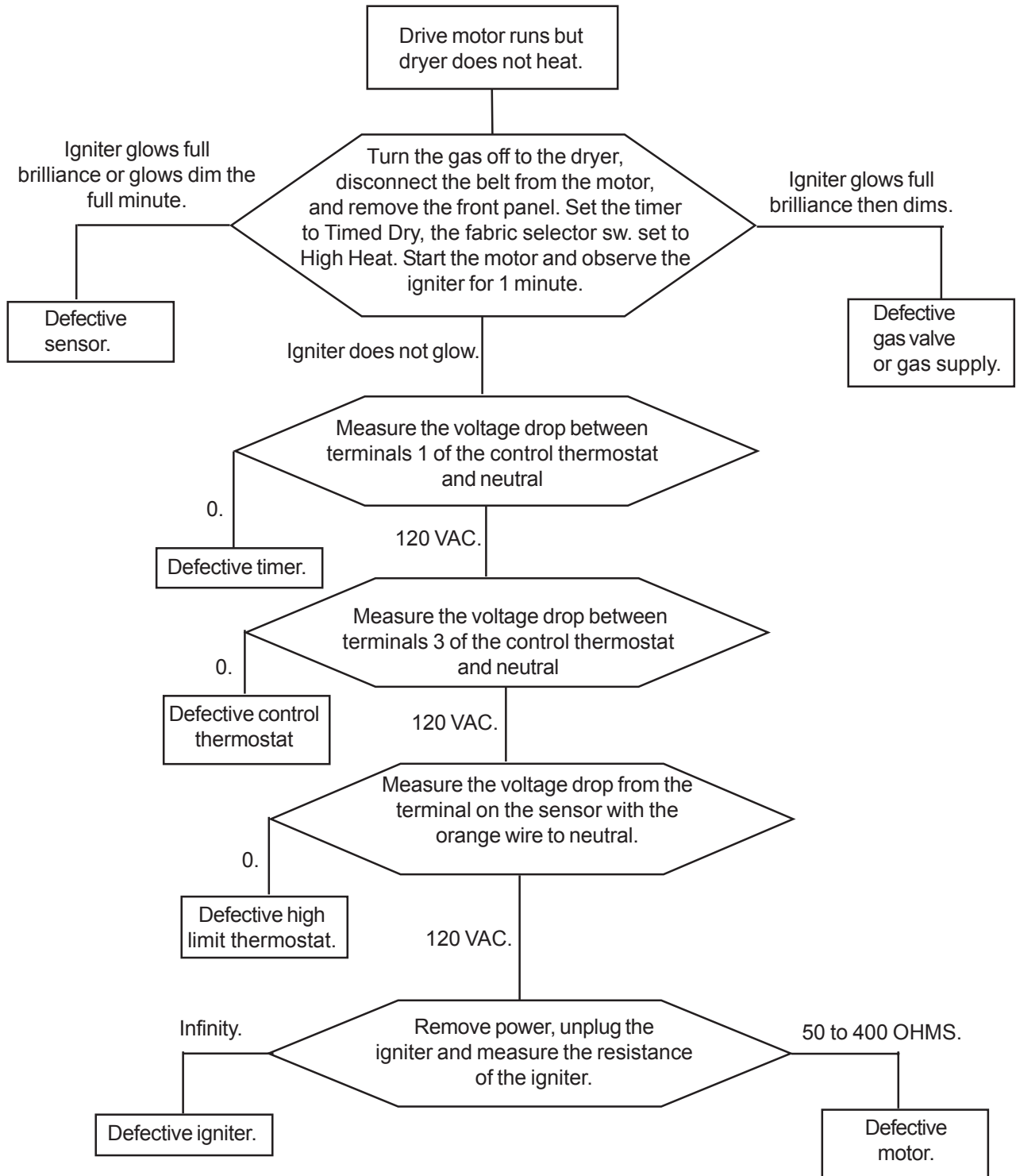

**Electric and Gas dryers; motor runs but timer does not advance in Auto or Timed Dry.**

**Note: Always check wiring to the components.**

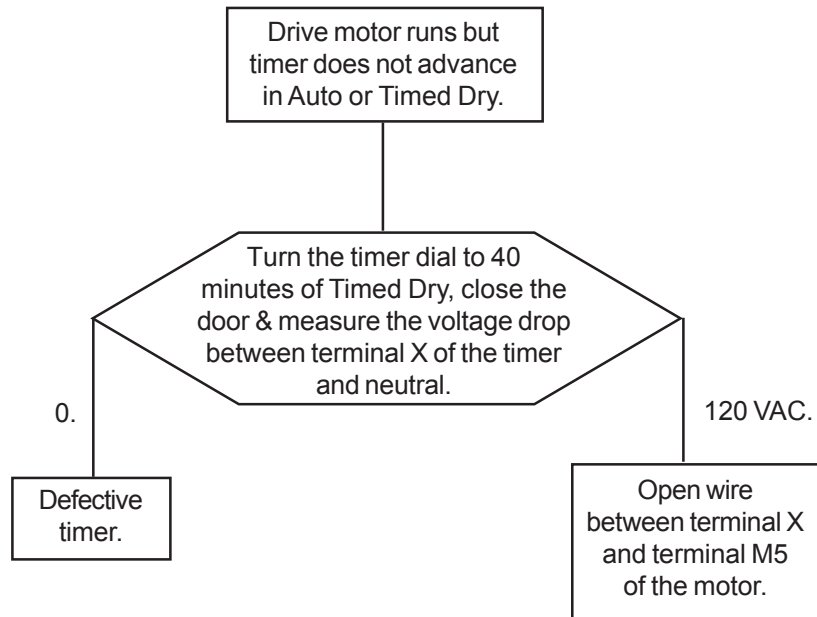

---

**Electric and Gas dryers; dryer overheats.**

**Note: Always check wiring to the components.**

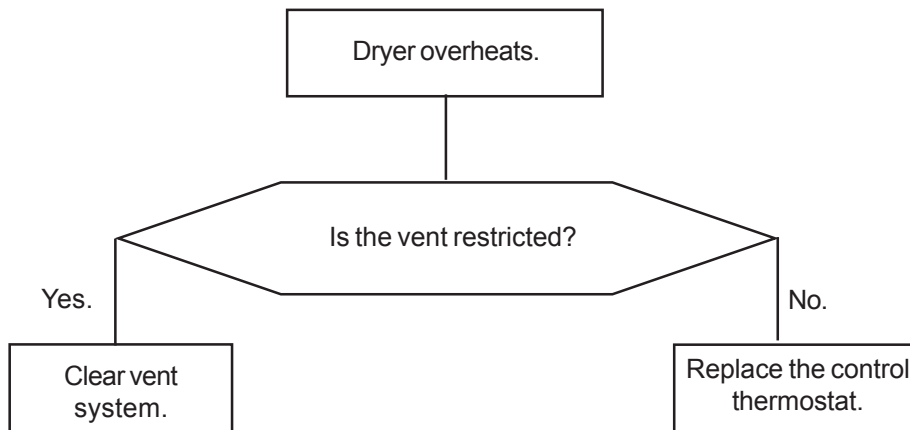

---

**Electric and Gas dryers; timer advances in Auto Dry but not in Timed Dry.**

**Note: Always check wiring to the components.**

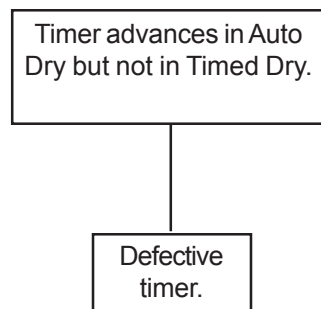



Speed control and motor plug and pin layout

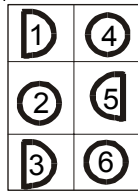

MOTOR PLUG - MALE  
(END VIEW)

10 PIN PLUG (C 10)  
SPEED CONTROL BOARD

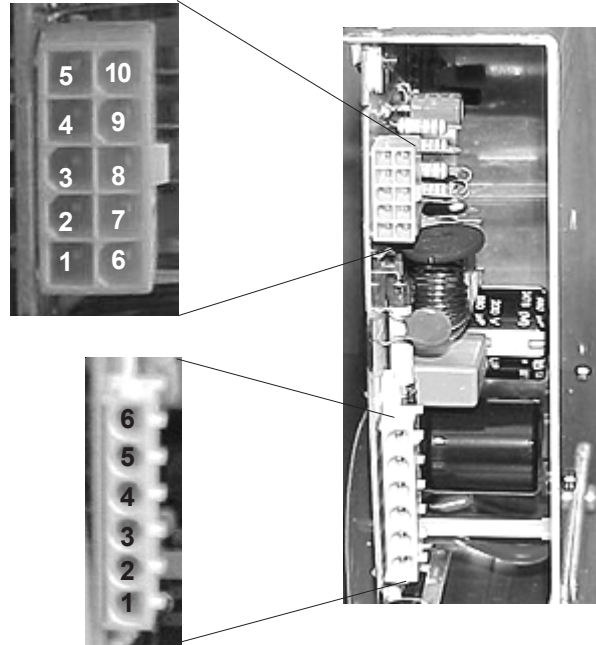

6 PIN PLUG (C 6)  
SPEED CONTROL BOARD

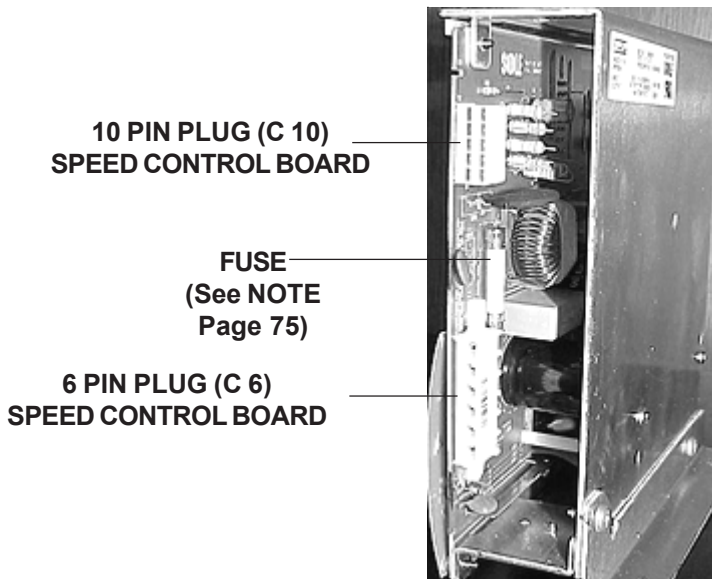

10 PIN PLUG (C 10)  
SPEED CONTROL BOARD

FUSE  
(See NOTE  
Page 75)

6 PIN PLUG (C 6)  
SPEED CONTROL BOARD

**Washer completely inoperative.**

**Note: Always check wiring to the components.**

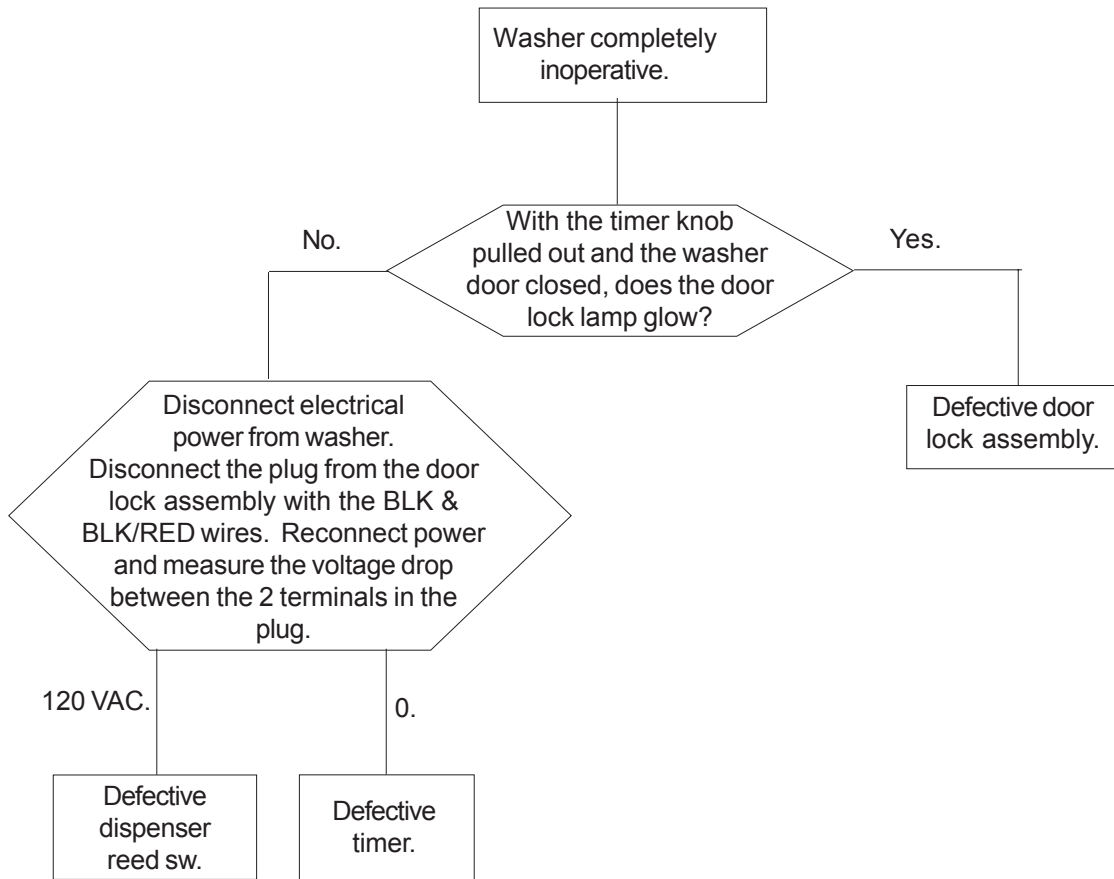

---

**Timer does not advance.**

**Note: Always check wiring to the components.**

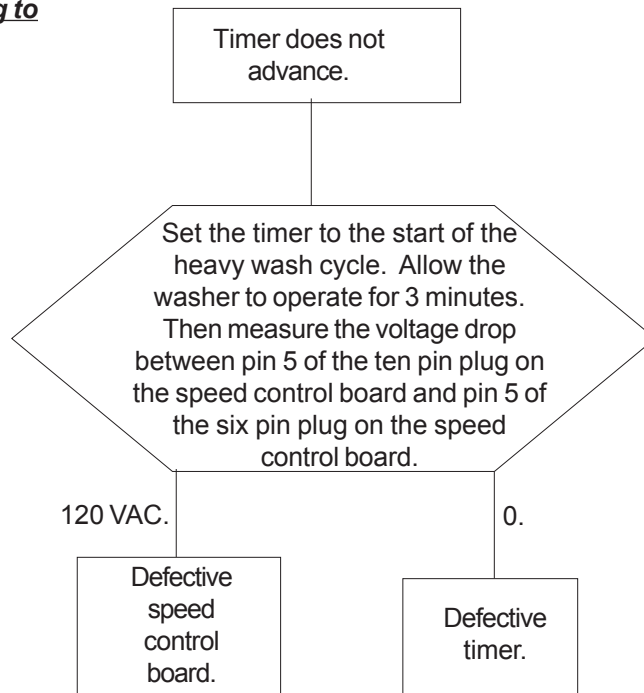

**Washer does not drain.**

**Note: Always check wiring to the components.**

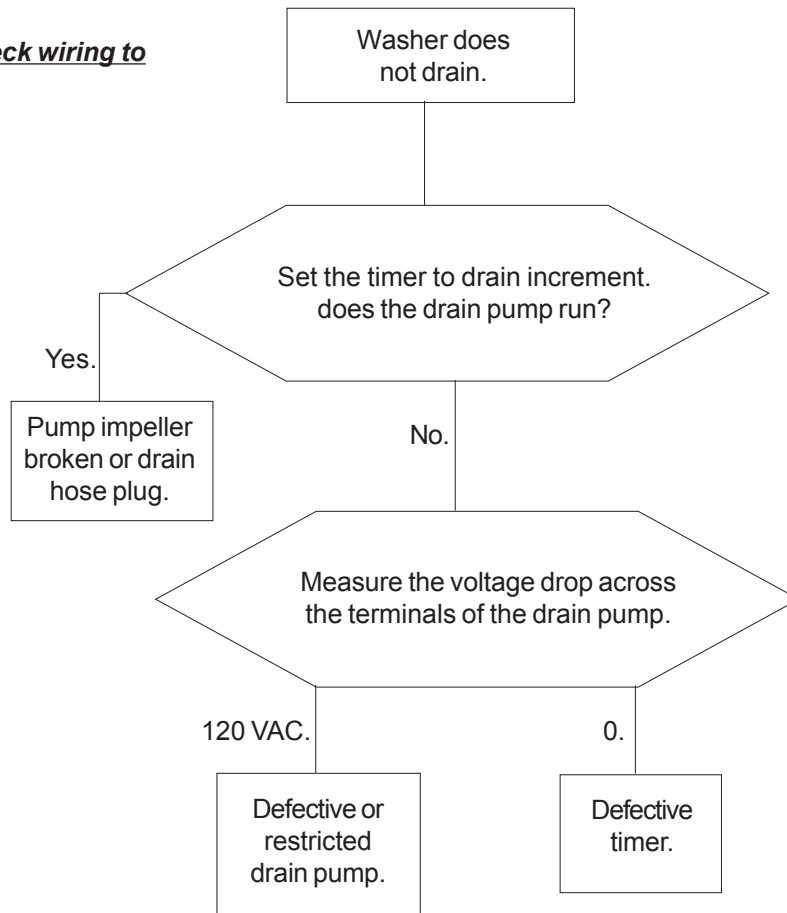

---

**Extra rinse setting does not work.**

**Note: Always check wiring to the components.**

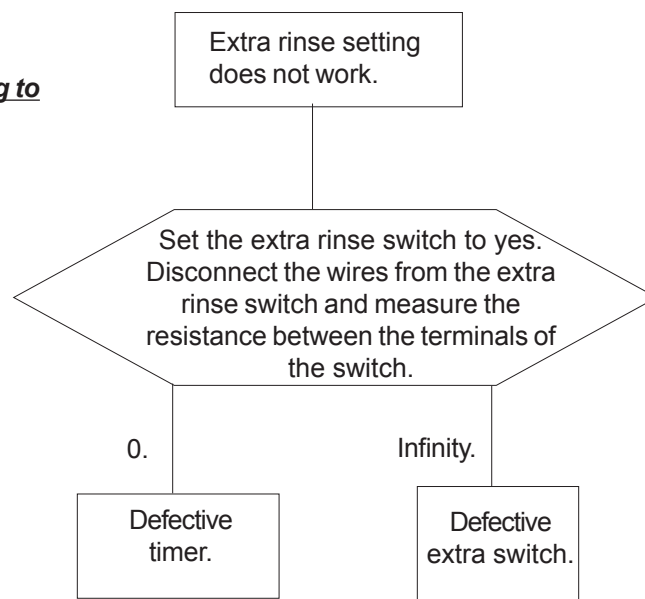

**Bleach dispenser does not operate.**

**Note: Always check wiring to the components.**

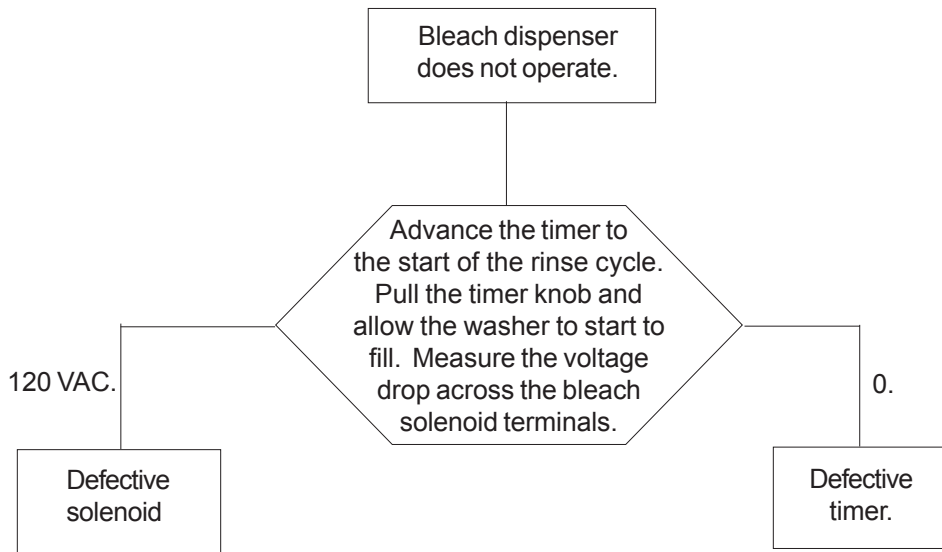

---

**Softner dispenser does not operate.**

**Note: Always check wiring to the components.**

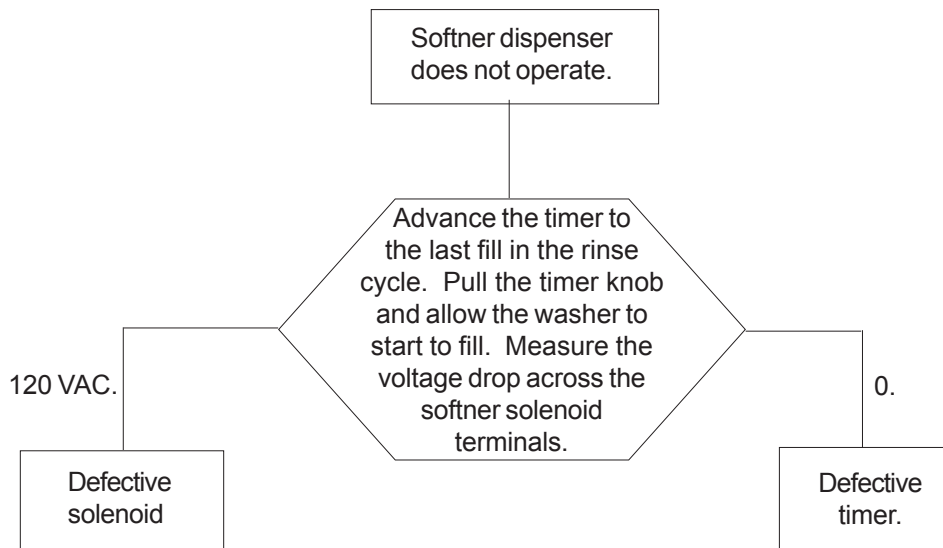

**Drive motor does not turn.**

**Note: Always check wiring to the components.**

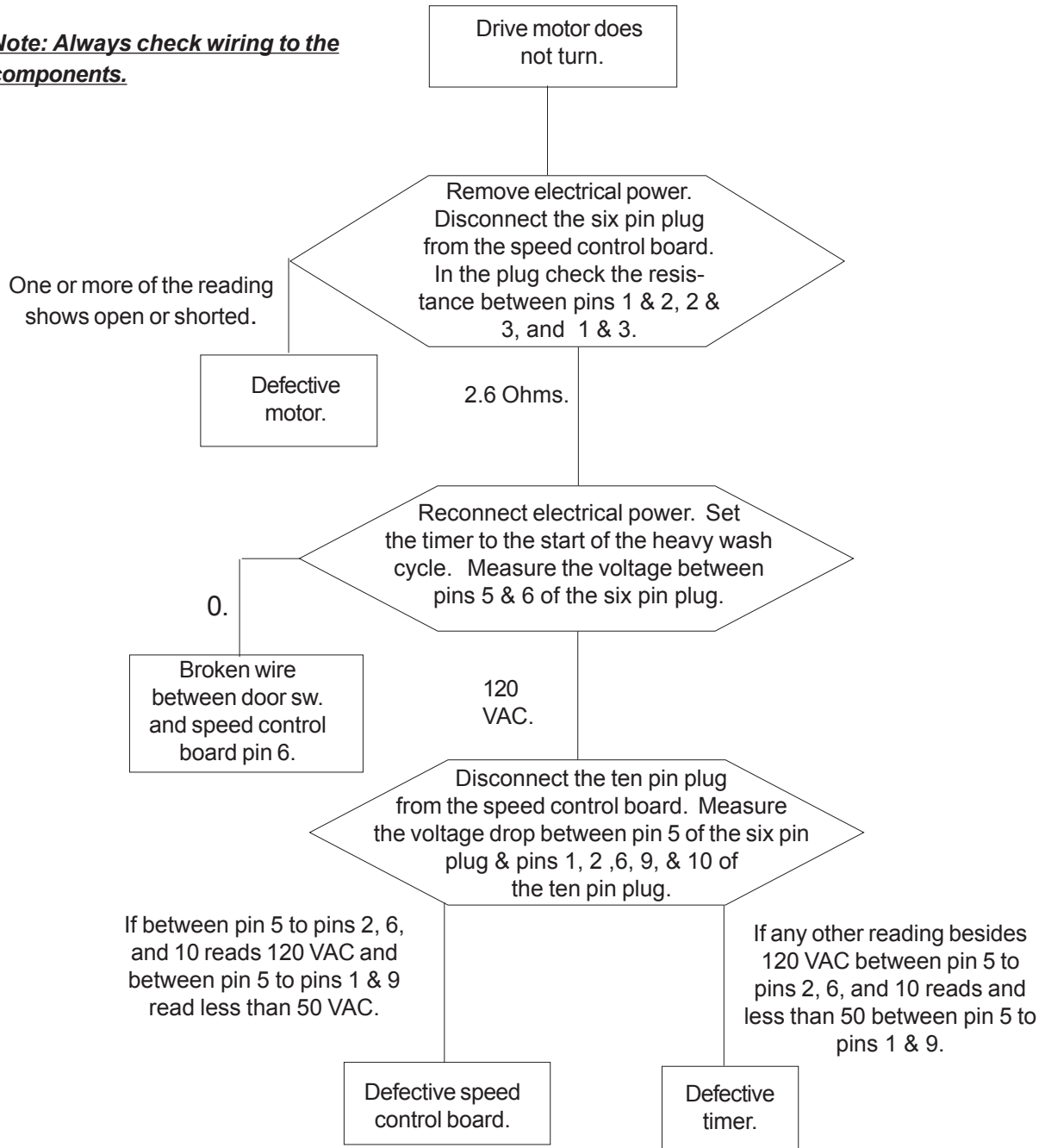

**NOTE: If the drive motor windings check open or shorted, check the fuse on the speed control board. If the fuse is open, replace the motor and speed control board.**

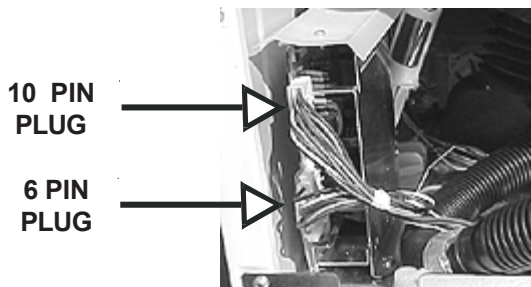

**Drive motor spins but does not tumble.**

**Note: Always check wiring to the components.**

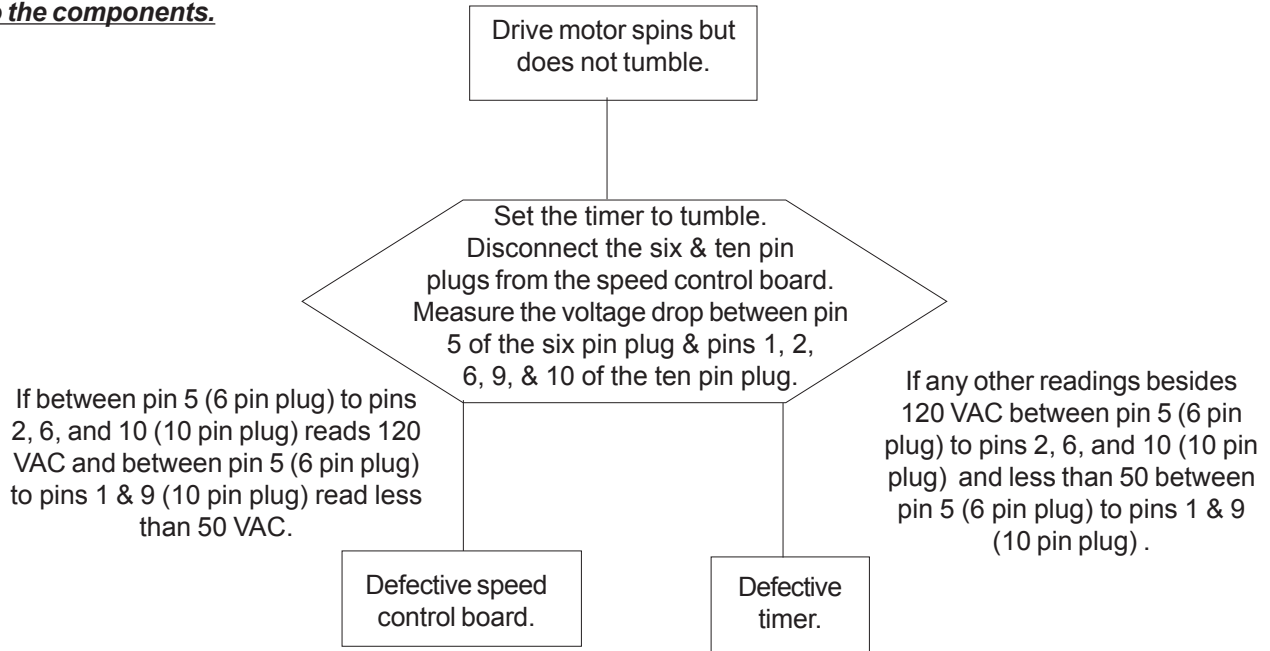

---

**Drive motor tumbles but does not spin.**

**Note: Always check wiring to the components.**

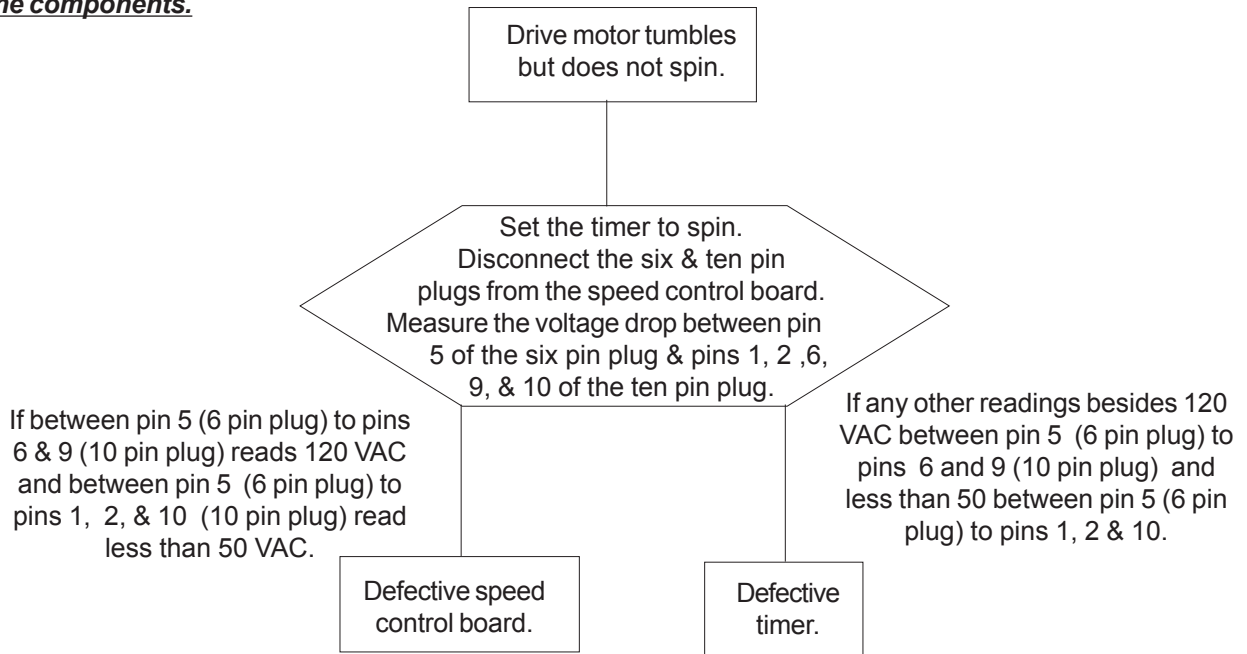



Drive motor tumbles very slowly in any timer position.

**Note: Always check wiring to the components.**

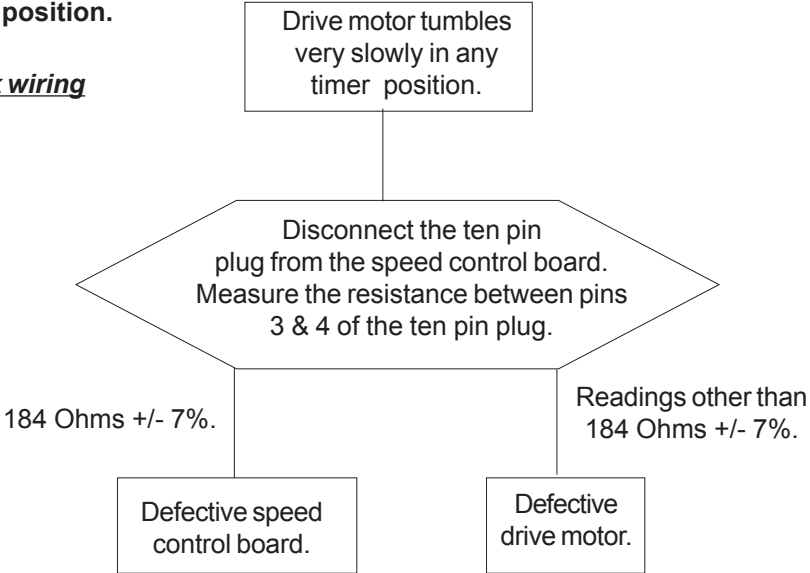

Spin cycle operating at incorrect speed for switch setting.

**Note: Always check wiring to the components.**

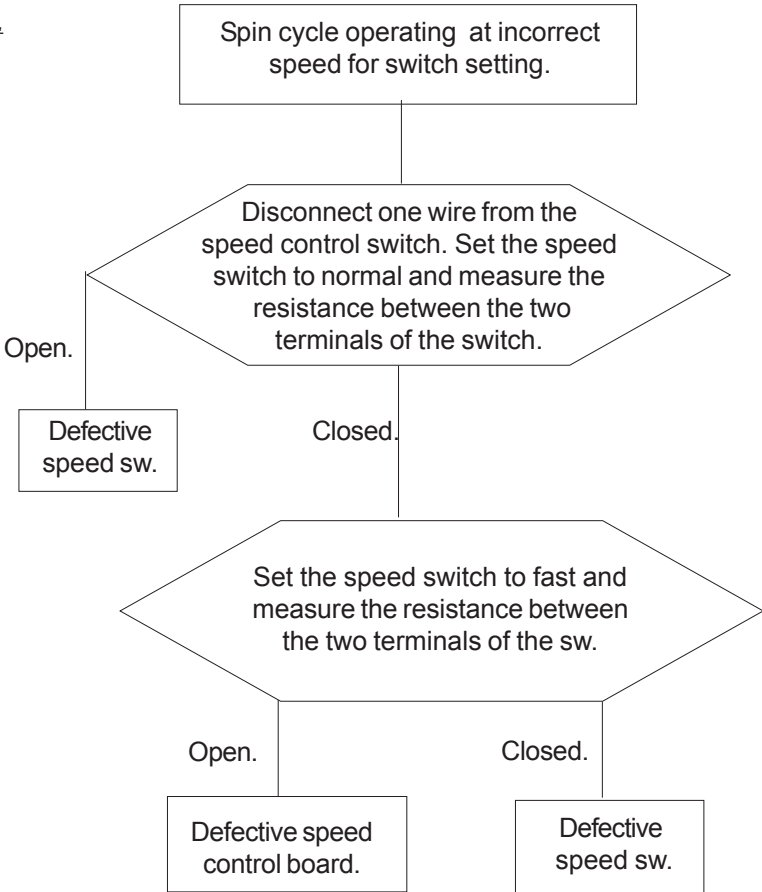

**Water fill does not turn off.**

**Note: Always check wiring to the components.**

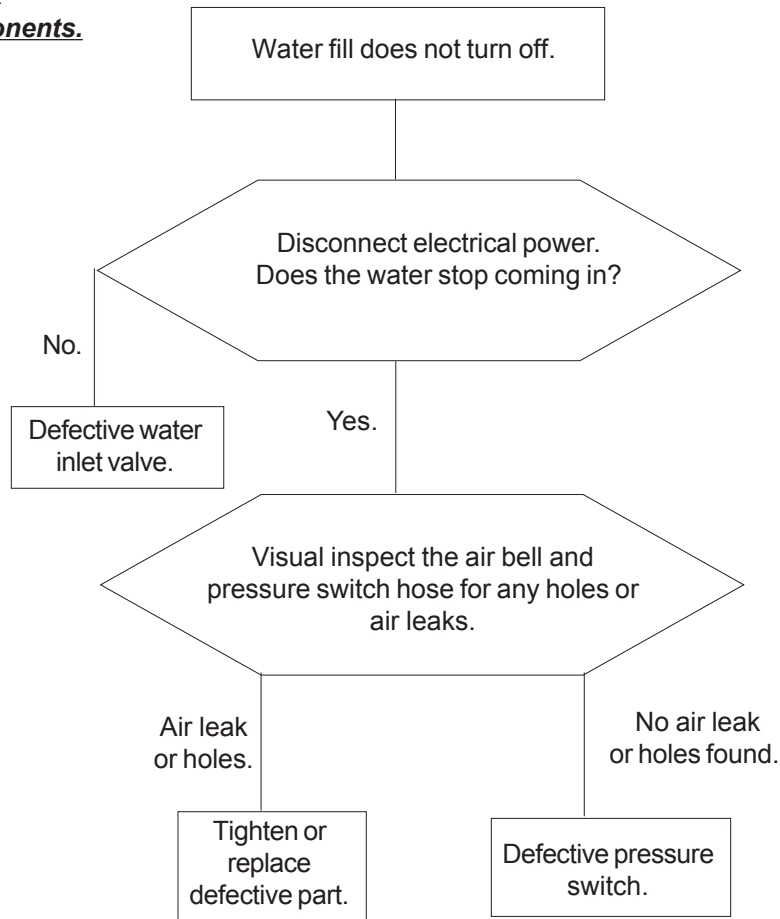

---

**Incorrect water level.**

**Note: Always check wiring to the components.**

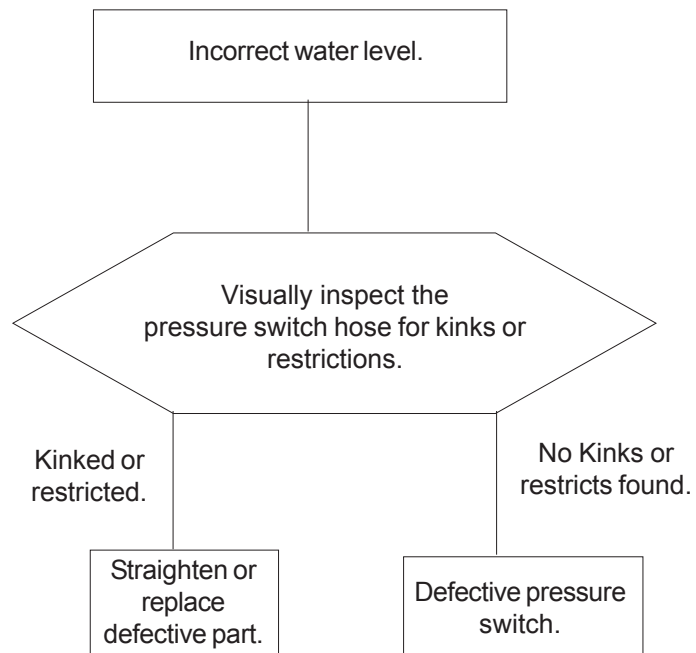

**Slow water fill.**

**Note: Always check wiring to the components.**

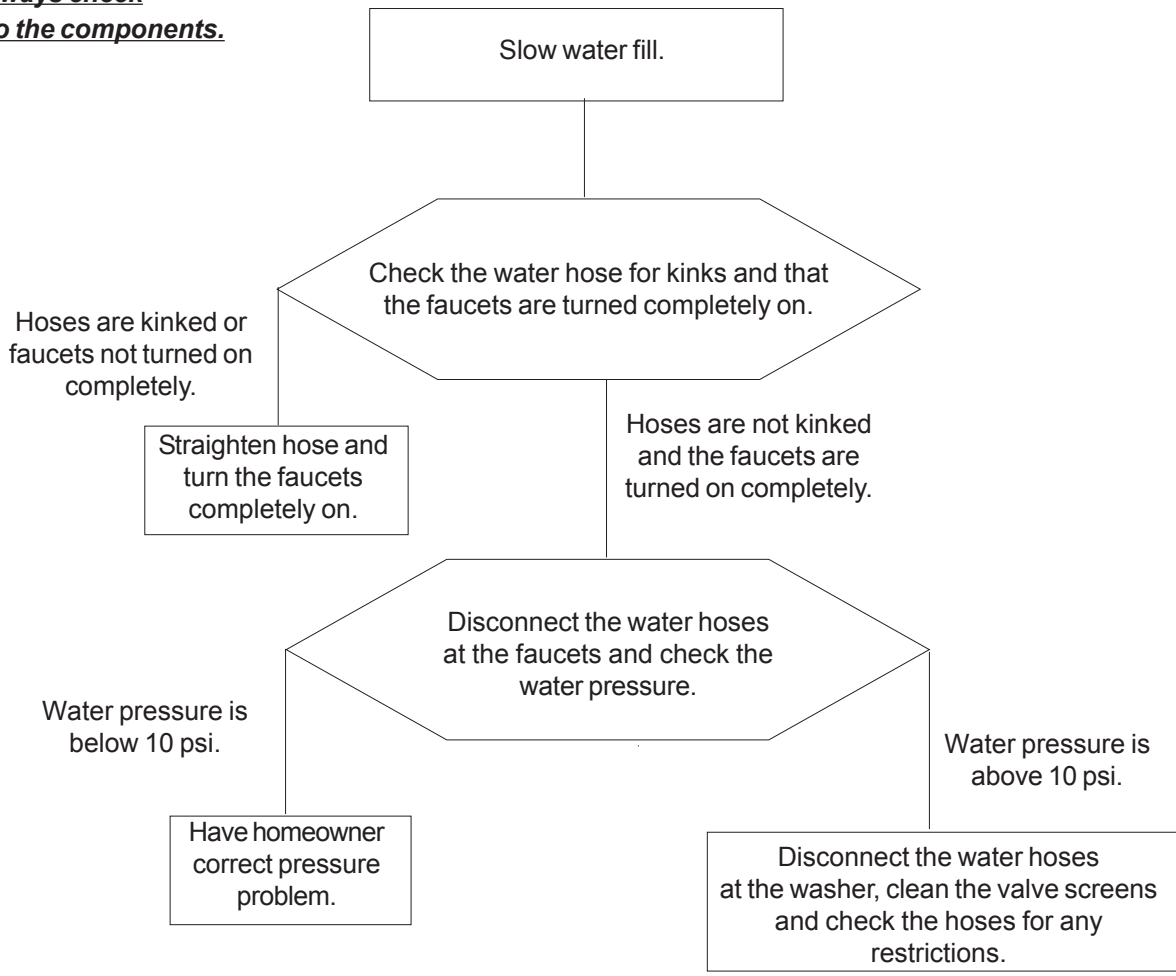

**Door indicator lamp does not glow.**

**Note: Always check wiring to the components.**

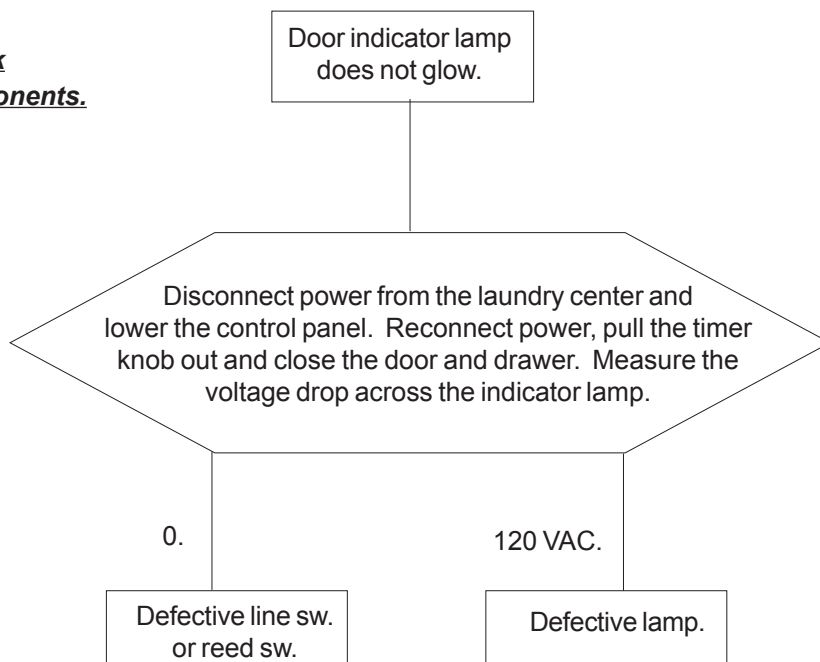

Washer will not fill in any setting of the temp switch.

**Note: Always check wiring to the components.**

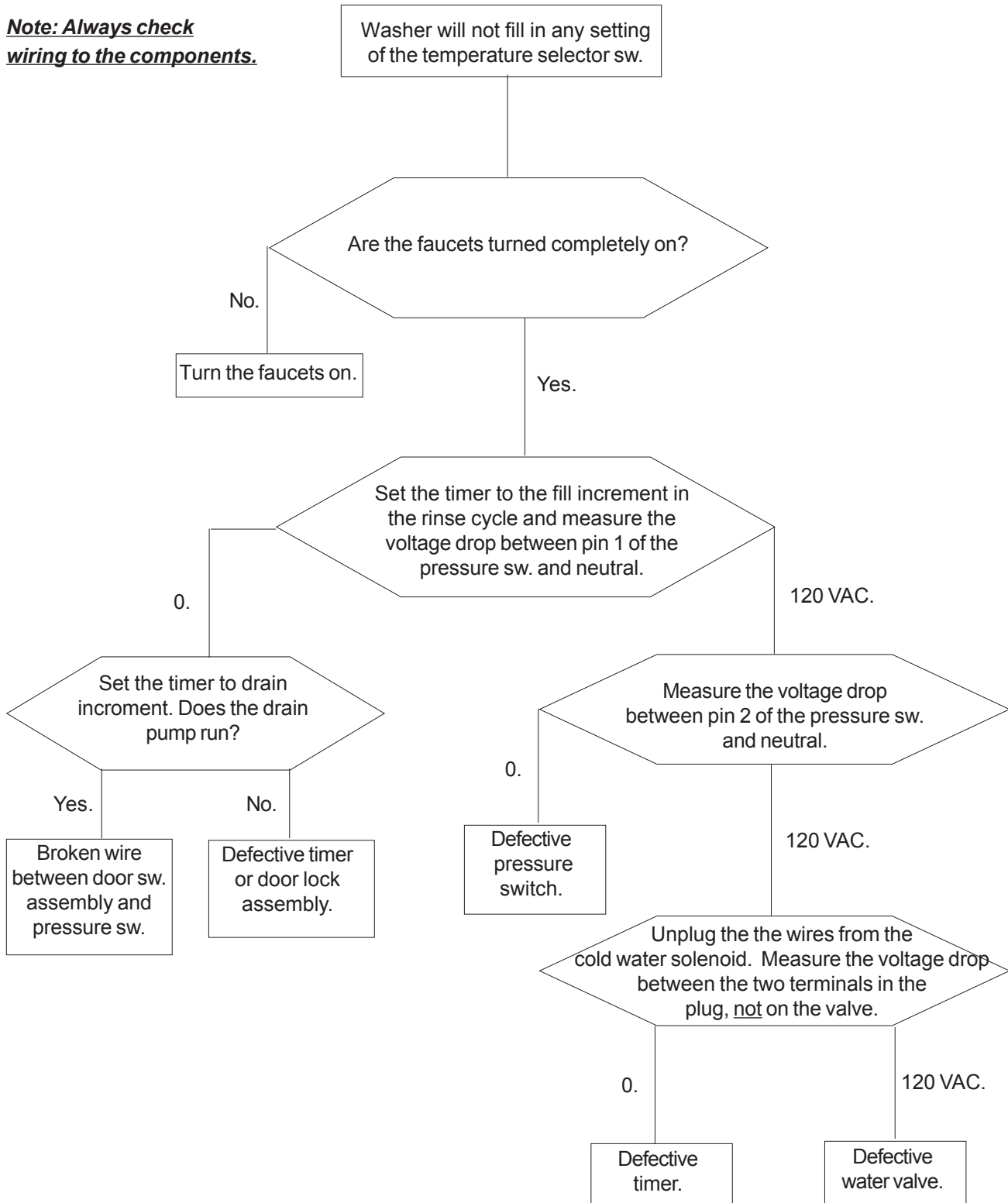

**Water temperature is too hot or too cold in the wash cycle with the temp switch set to warm/warm.**

**Note: Always check wiring to the components.**

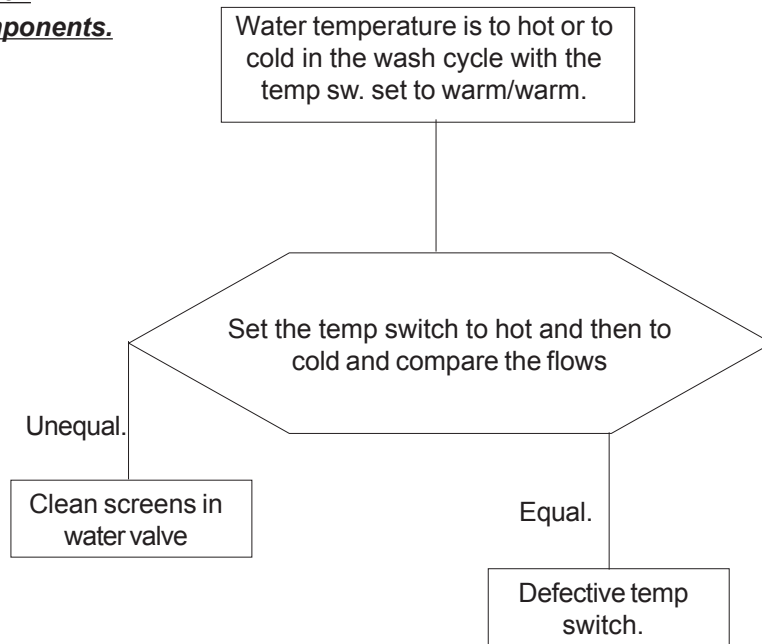

---

**Washer will only fill with hot water in the wash cycle, with the temp switch set to warm/cold but does fill with cold in the rinse cycle.**

**Note: Always check wiring to the components.**

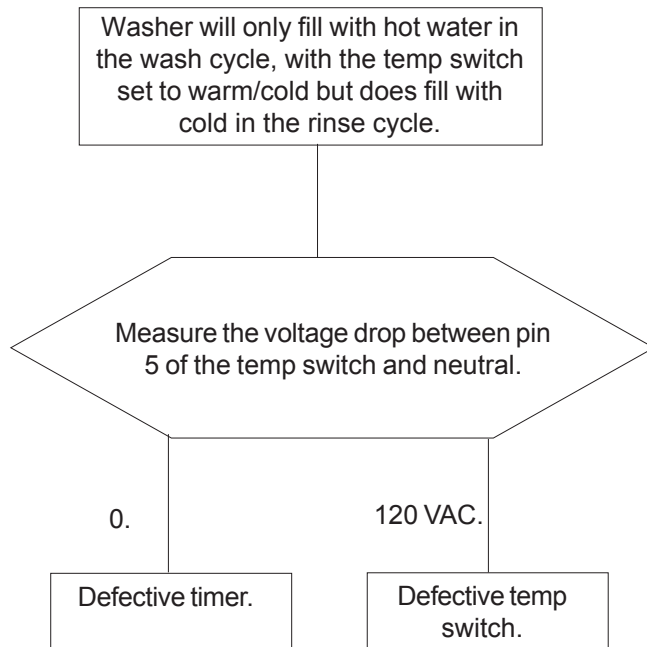

## SECTION H - TEARDOWN

This section will describe how to remove components from both gas and electric laundry centers. Unless stated, the procedure will be the same on all laundry centers. Unless stated, reverse the procedure to reinstall the component.

**⚠ WARNING** Always remove electrical power from the laundry center when working in an area where electrical power is present.

**⚠ WARNING** Always turn the gas off to the laundry center before opening any gas piping.

### Removing the knobs.

#### All knobs except the washer timer knob:

1. The shafts of the knobs are D shaped and pull straight off.

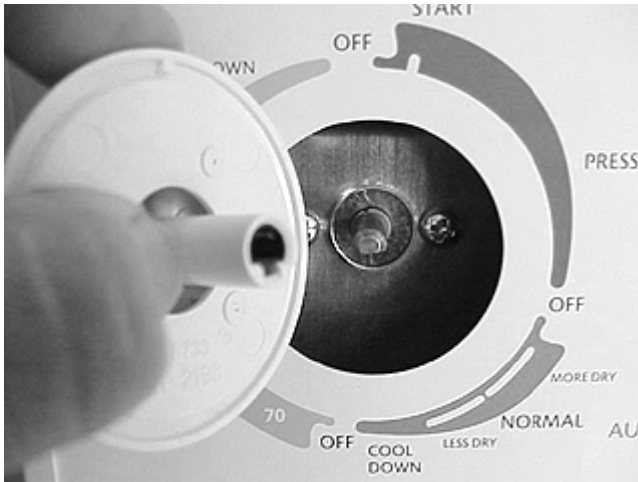

2. To remove the washer timer knob, push the knob in and turn counter clockwise.

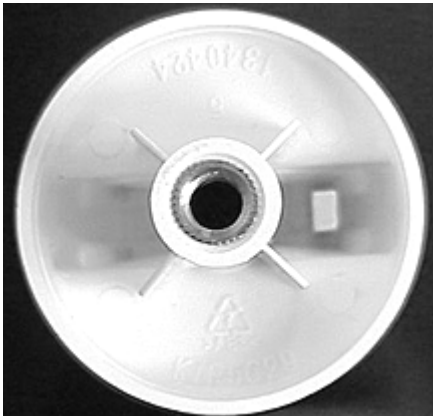

### Removing washer timer pointer:

1. Remove the timer knob and pull the timer pointer off.

**Note:** Be careful not to loose the small metal washer between the knob and pointer.

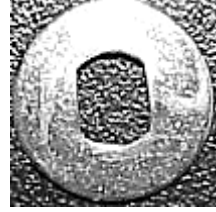

### Removing the access panel:

1. The access panel is held to the upper side panels by two screws and two tabs. Remove the two screws and pull up and out to remove the panel.

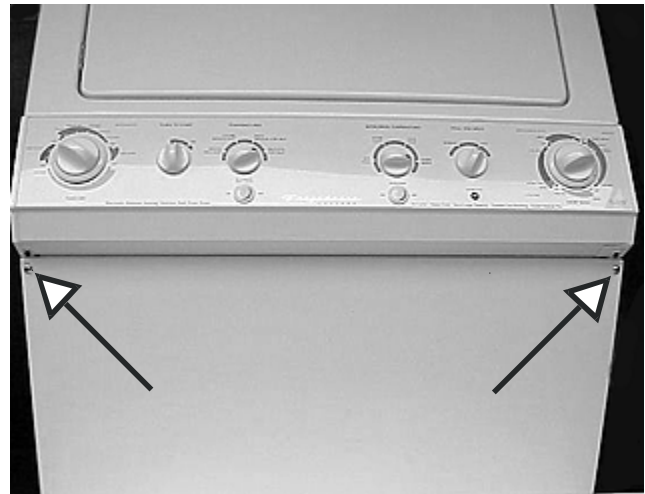



### Opening the console:

1. Disconnect power from the laundry center and remove the access panel.
2. Remove the four screws, two on each side, holding the console to the dryer section side panels.

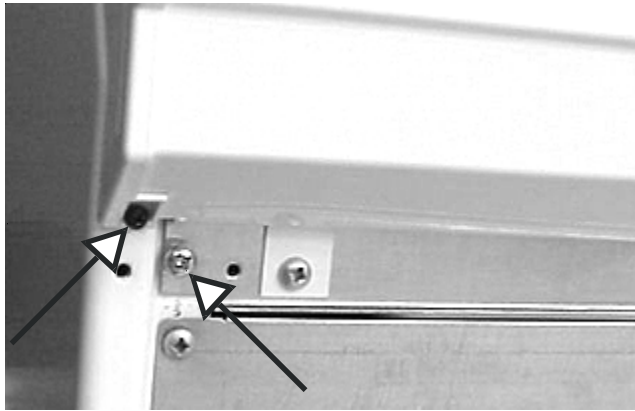

3. Pull down and out on the console to release the taps from the side panels. The console will now hang on the wires and pressure switch hose.



### Removing the dryer timer:

1. Disconnect the laundry center from the electrical supply.
2. Remove the timer knob and open the console.

3. Mark and disconnect the wires from the timer.

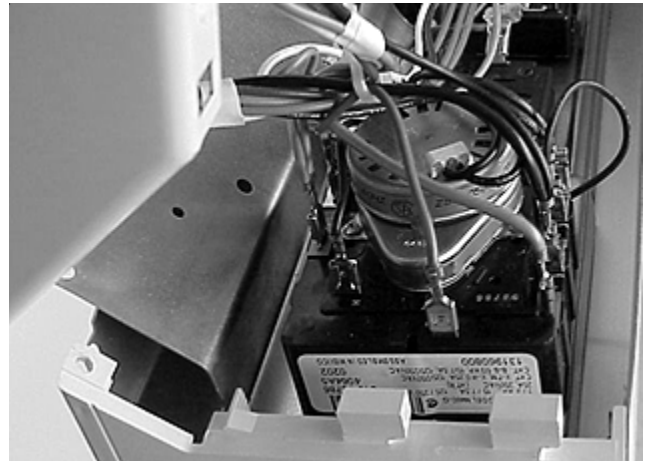

4. Remove the two screws holding the timer to the console panel.

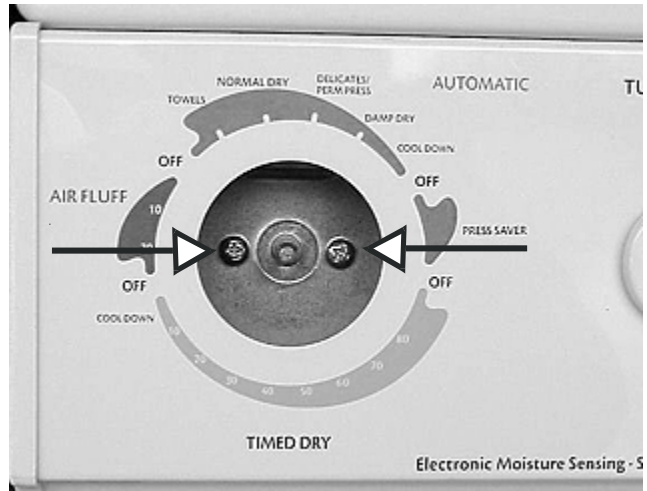

### Removing the dryer buzzer:

1. Disconnect the laundry center from the electrical supply.
2. Open the console panel and disconnect the two wires for the buzzer at the timer.

3. Remove the screw holding the buzzer to the control mounting panel.

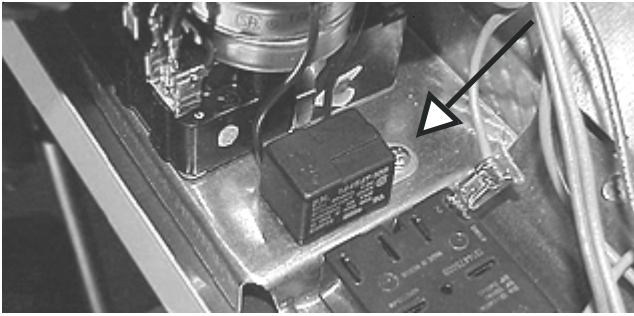

**Removing the console end caps:**

1. Disconnect the laundry center from the electrical supply and open the console.
2. Remove the two screws holding the end cap to the control mounting panel and the screw in the top holding the end cap to the front panel. Slide the end cap out.

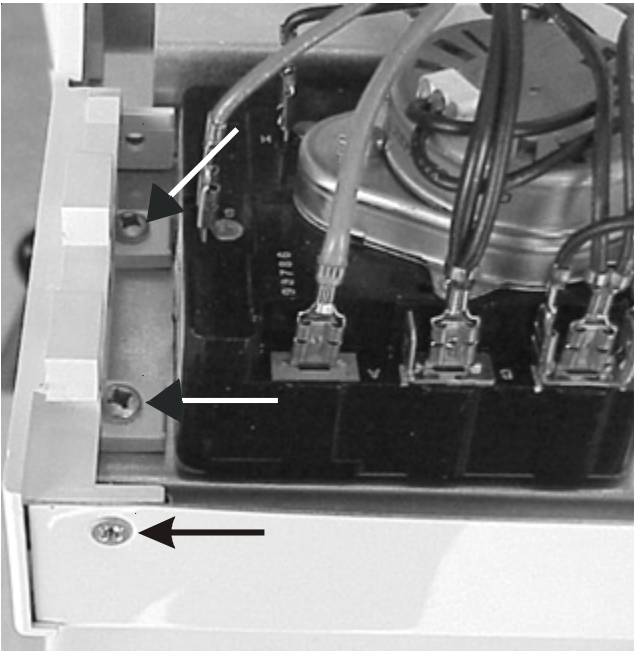

**Removing the console front panel:**

1. Disconnect the laundry center from the electrical supply, remove the knobs and the washer timer skirt.
2. Open the console and remove the console end caps.

3. Remove the two screws, one at each end, holding the console front panel to the control mounting panel and lift the front panel off.

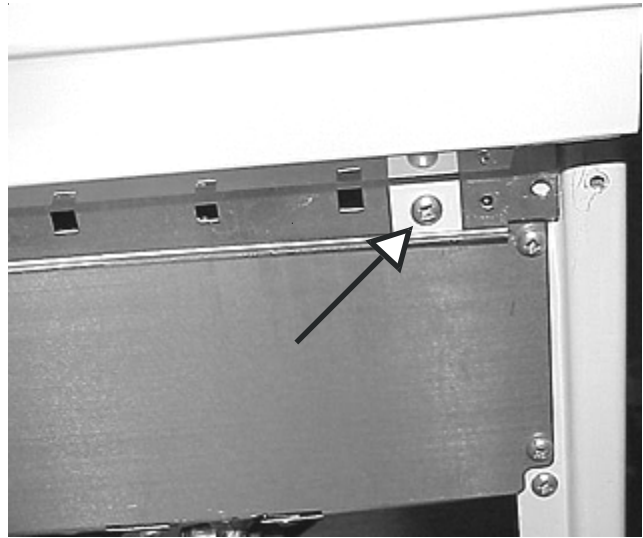

**Removing the start switch:**

1. Disconnect the laundry center from the electrical supply, open the console and remove the console front panel.
2. Disconnect the wire from the start switch, remove the two screws holding the start switch to the control mounting panel and pull the switch out the back.

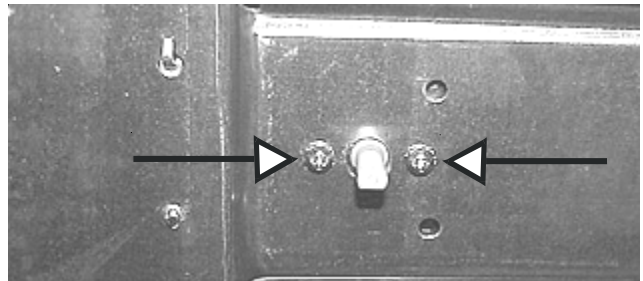
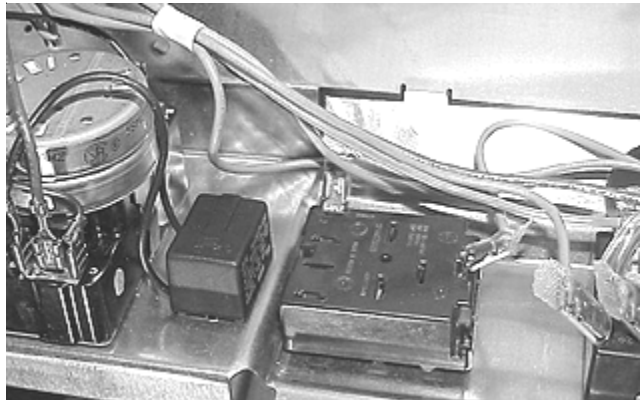

### Removing the temperatures switch:

1. Disconnect the laundry center from the electrical supply, remove the knob from the temperatures switch and open the console
2. Disconnect the wire from the temperatures switch, remove the two screws holding the temperatures switch to the control mounting panel and pull the switch out the back.

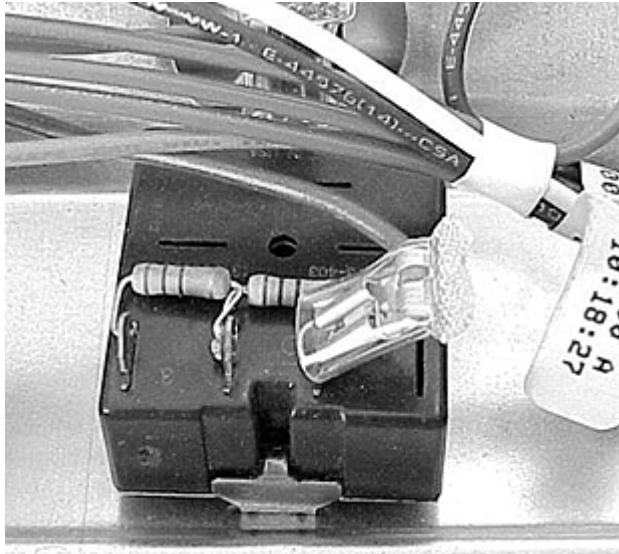

2. Disconnect the wire from the press saver switch, squeeze tabs on the side of the switch and push the switch out the front of the control panel.

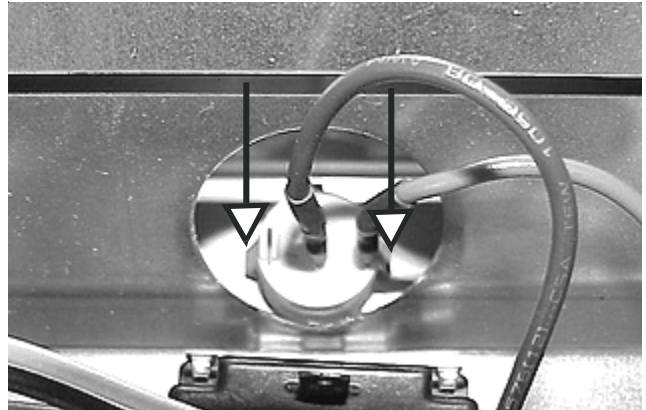

### Removing the water temperature switch:

1. Disconnect the laundry center from the electrical supply, remove the knob and open the console.
2. Disconnect the wire from the water temperature switch, release the locking tab, turn the switch about 1/8 of a turn clockwise and pull the switch out the back.

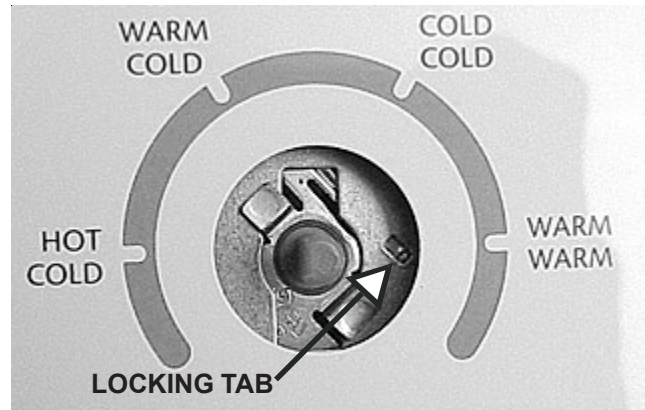
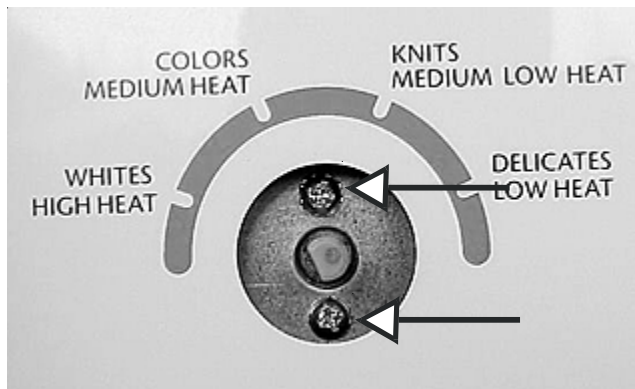

### Removing the automatic press saver switch:

1. Disconnect the laundry center from the electrical supply and open the console.

### Removing the extra rinse switch:

1. Disconnect the laundry center from the electrical supply and open the console.



2. Disconnect the wire from the extra rinse switch, squeeze tabs on the side of the switch and push the switch out the front of the control panel.

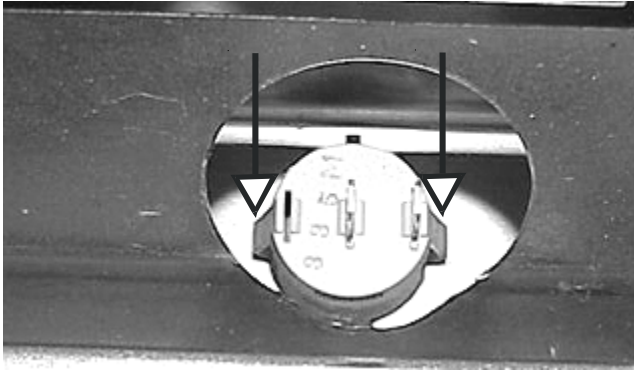

**The door lock lamp assembly:**

The door lock light assembly is made up of a lens and the lamp. The lens is inserted through the front of the control panel and the lamp is snapped to the lens and held against the console panel by spring load plastic tabs.

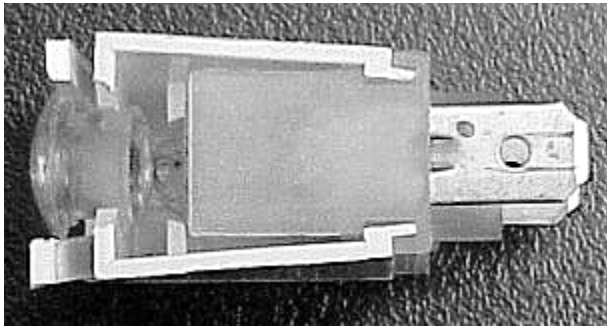

**Removing the door lock lamp assembly:**

1. Disconnect the laundry center from the electrical supply and open the console.
2. Disconnect the wire from the lock lamp, push in on the lamp and slide the lamp away from the end of the lamp with the tabs.

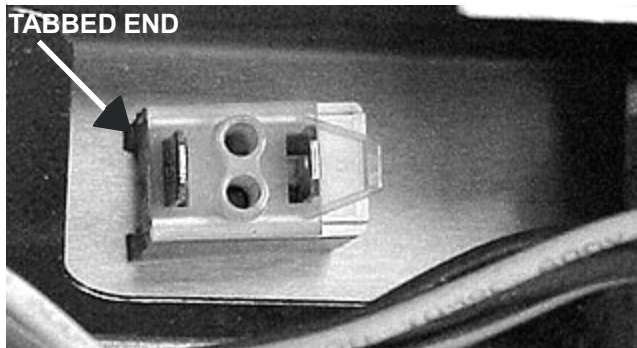

**Removing the washer buzzer:**

1. Disconnect the laundry center from the electrical supply.
2. Open the console panel and disconnect the two wires for the buzzer at the timer.
3. Remove the screw holding the buzzer to the control mounting panel.

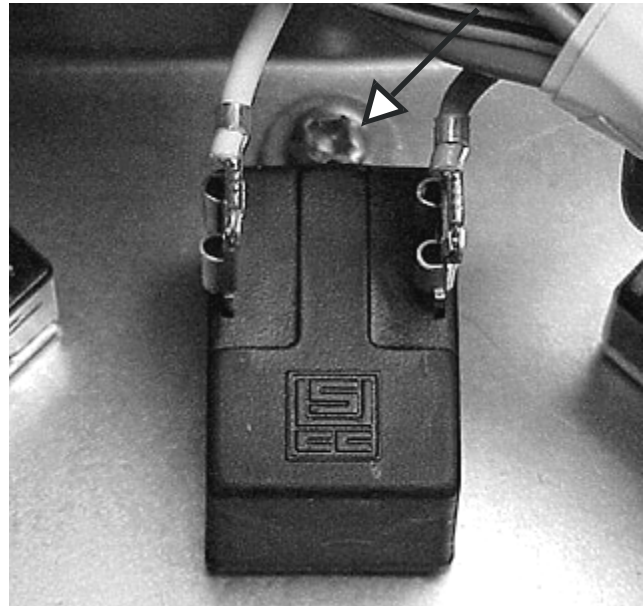

**Removing the final spin speed switch:**

1. Disconnect the laundry center from the electrical supply, remove the knob from the speed switch and open the console
2. Disconnect the wire from the speed switch, remove the two screws holding the speed switch to the control mounting panel and pull the switch out the back.

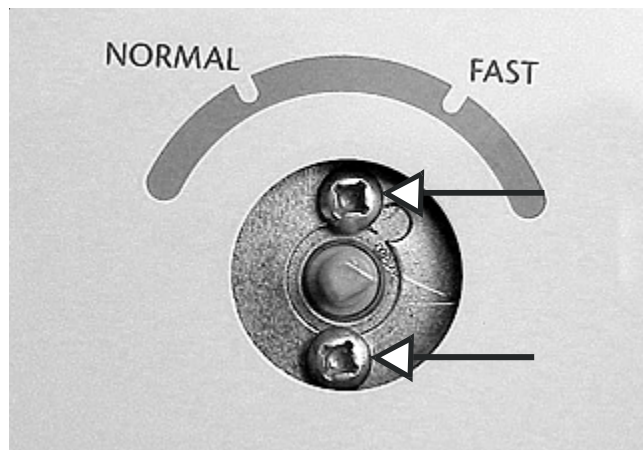

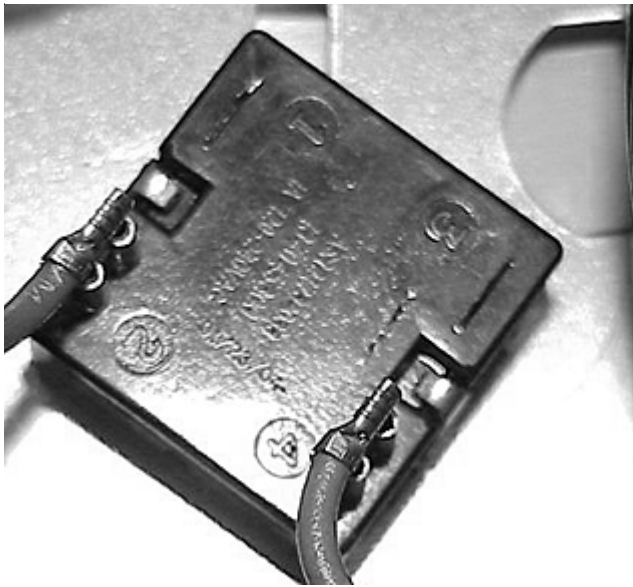

**Removing the electronic moisture sensor control:**

1. Disconnect the laundry center from the electrical supply and open the console.
2. Unplug the harness from the control, push down on the bottom bracket, and slide the control out the end.

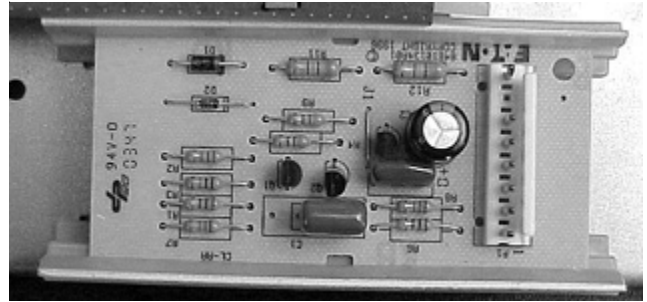

**Removing the washer timer:**

1. Disconnect the laundry center from the electrical supply, remove the knob and bezel and open the console.
2. Unplug the harness from the timer and remove the two screws holding the timer to the console.

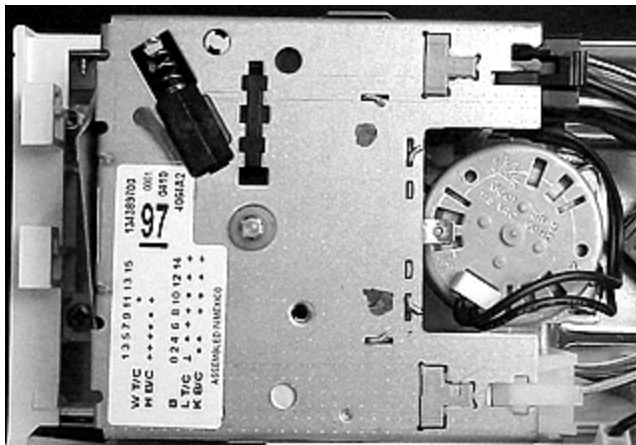

**Removing the dryer door:**

1. Open the door and remove the four screws holding the door to the hinges.

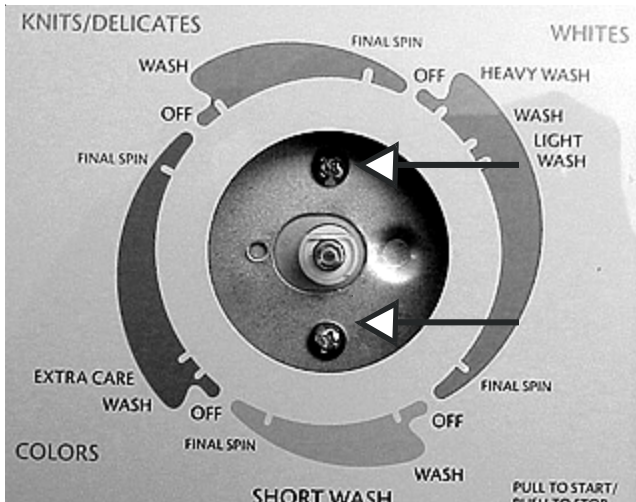
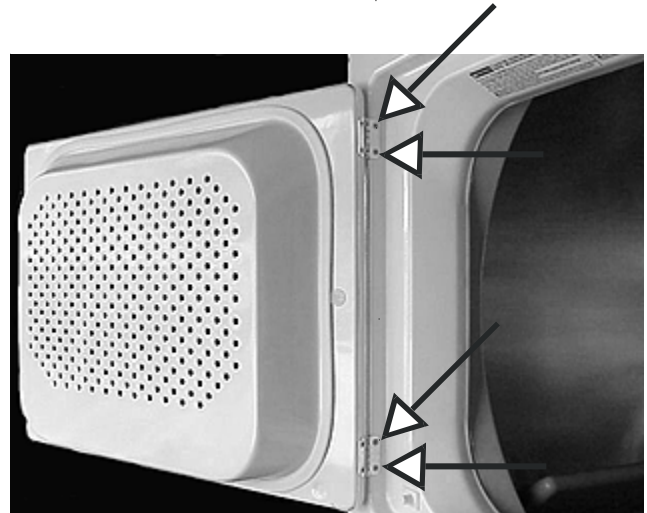

**Separating the dryer door panel:**

1. Remove the door.

- Remove the two screws from the end and two screws from the bottom.

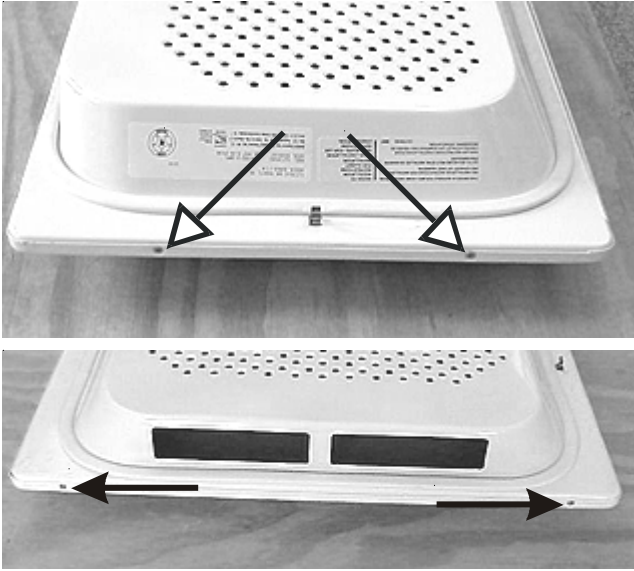

- Lift the inner panel off the outer panel.

#### Removing the dryer door seal:

- The door seal is fastened to the inner door liner by expandable tabs pushed through slots in the liner.

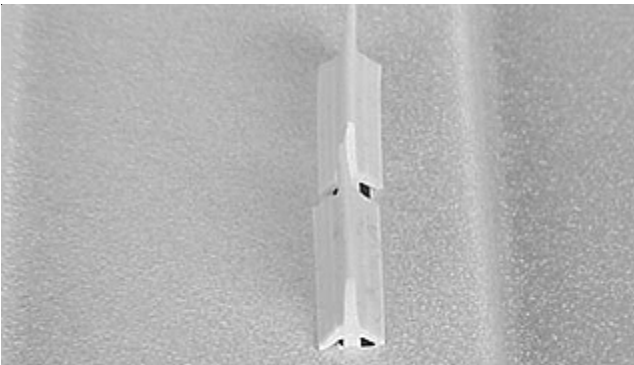

- If the seal is to be replaced, open the door and pull the seal from the liner. If the seal is to be reused, separate the panels and use a small screwdriver to push the tabs through the liner.

#### Removing the dryer door heat shield:

- Separate the door panels and lift the heat shield out of the outer panel.

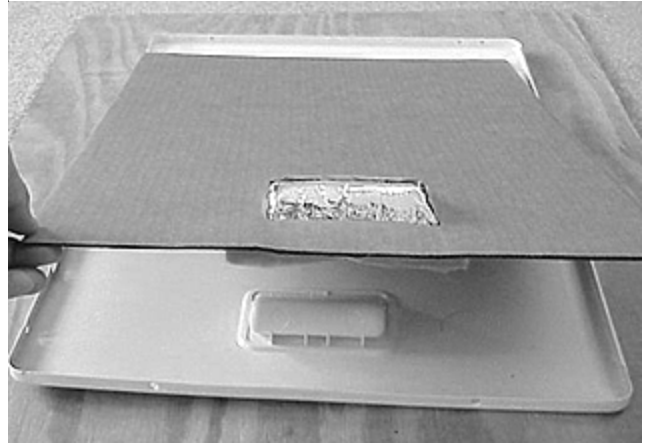

#### Removing the dryer door handle:

- Separate the panel and release the tabs holding the handle in outer panel.

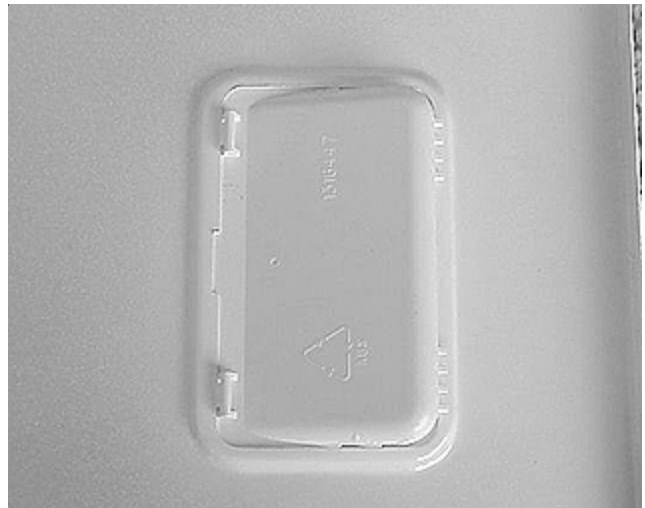



### Removing the dryer door strike:

1. Separate the panel, squeeze the ends of the strike and push it through the inner panel.

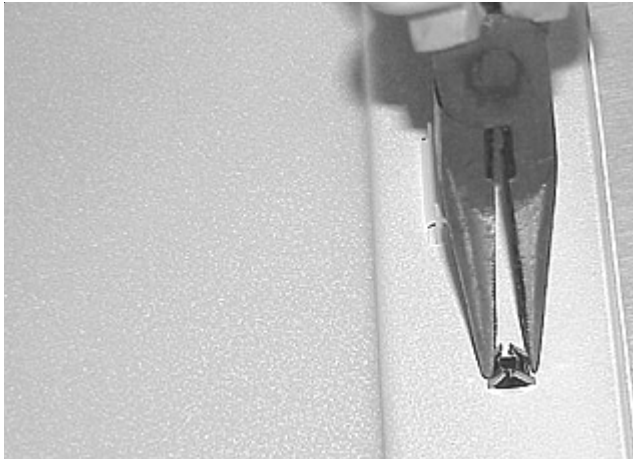

2. Reach behind the dryer front panel, squeeze the ends of the strike and push it through the inner panel.

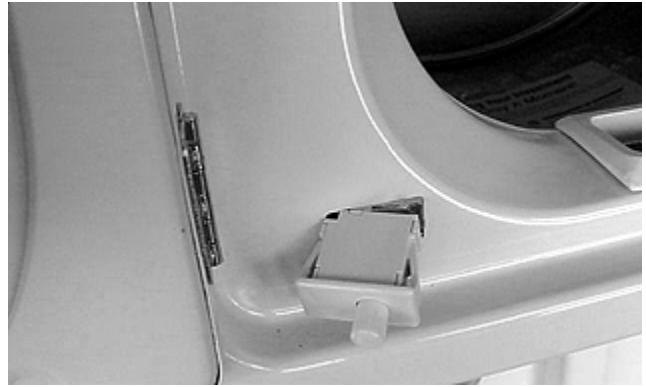

### Removing the dryer door hinge:

1. Hold the weight of the door and remove the four screws from the hinge

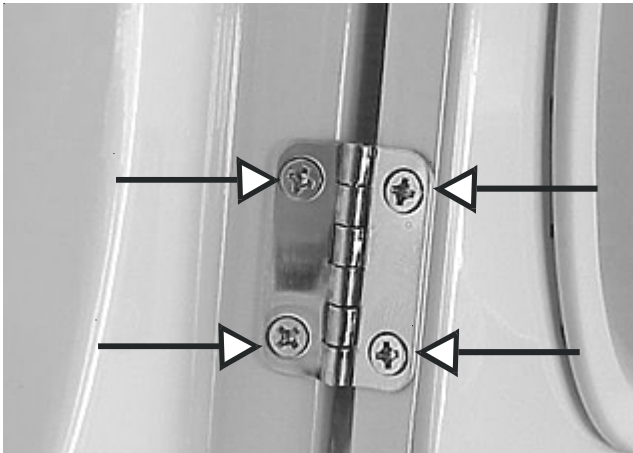

### Removing the heat shield:

1. Disconnect the laundry center from the electrical supply and remove the access panel.
2. Remove the six screws, four holding the heat shield to the side panels and two holding the heat shield to the dryer section base.

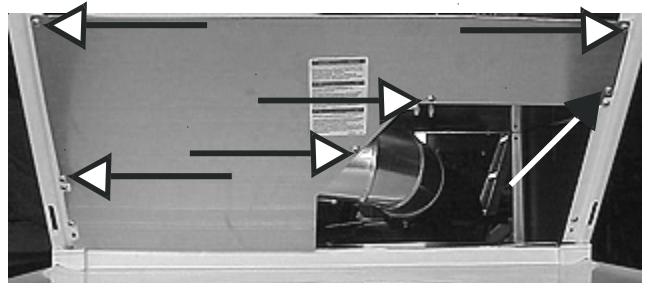

### Removing the dryer front panel:

1. Disconnect the laundry center from the electrical supply, remove the access panel and heat shield.
2. Open the console and remove the two screws holding the front panel to the side panels.

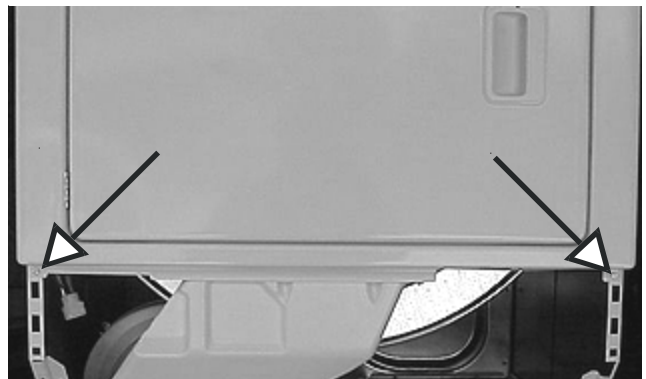

### Removing the dryer door switch:

1. Disconnect the laundry center from the electrical supply and open the console.

3. Unplug the dryer door switch harness.

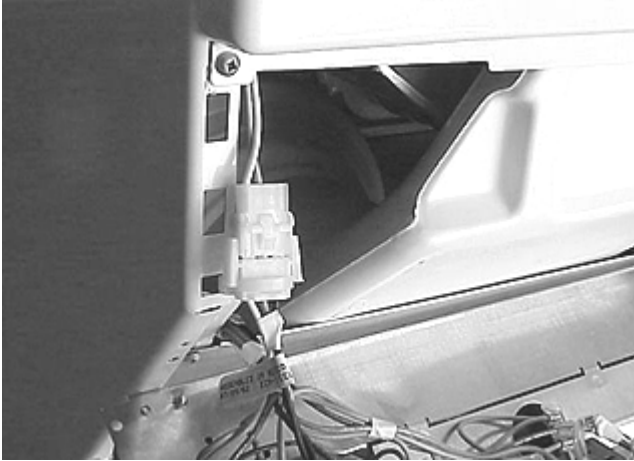

4. Remove the four screws holding the front panel to the top and carefully pull the front panel forward.

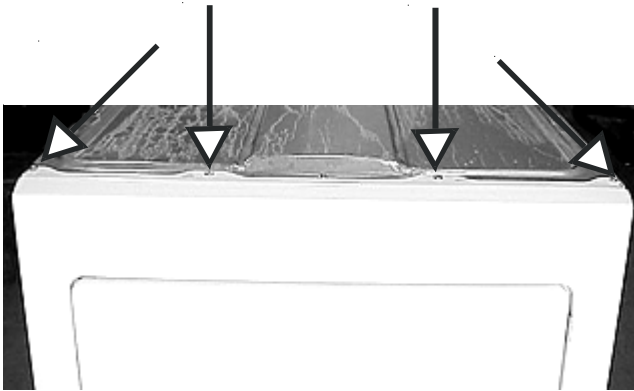

#### Replacing the felt seals:

1. Disconnect the laundry center from the electrical supply and remove the dryer front panel.
2. The felt seals are two seals that are glued to front panel rim that the drum rides on.
3. To replace either seal, pull the seals off and glue the replacements to the rim.

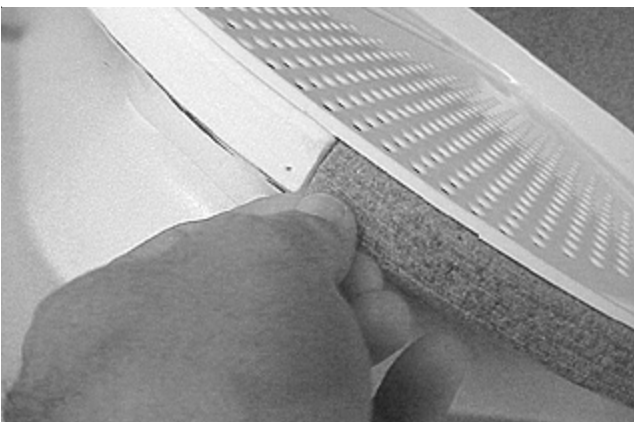

#### Replacing the front duct:

1. Disconnect the laundry center from the electrical supply and remove the dryer front panel.
2. Lift the filter out and remove the two screws holding the duct to the front panel.

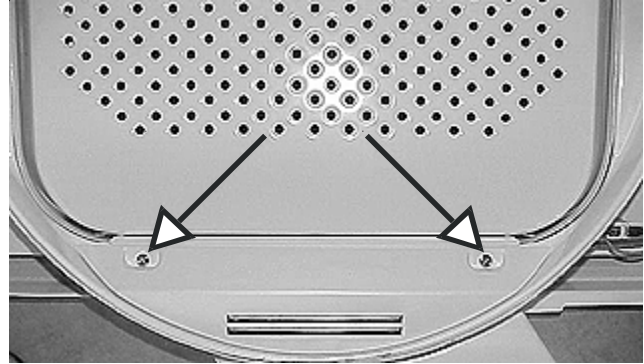

#### Removing the door catch:

1. Disconnect the laundry center from the electrical supply and remove the dryer front panel.
2. Push up and forward and down and forward on the rear of the catch moving the catch forward until the metal tabs hit the front panel.
3. Release the metal tabs with a small screwdriver and push the catch out the front.

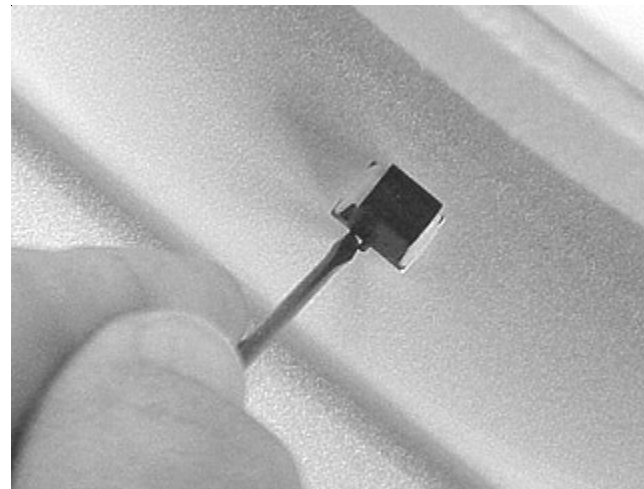

#### Replacing the foam seal:

1. Disconnect the laundry center from the electrical supply and remove the dryer front panel.
2. The foam seal, glued to the blower assembly duct, provides a seal between the front panel duct and the blower housing assembly.

3. To replace the seal, pull the seal off and glue the replacement to the duct.



**Removing the dryer section rear access panel:**

1. Remove the two screws holding the access panel to the rear panel and swing the right side of the panel out to disengage the tabs.

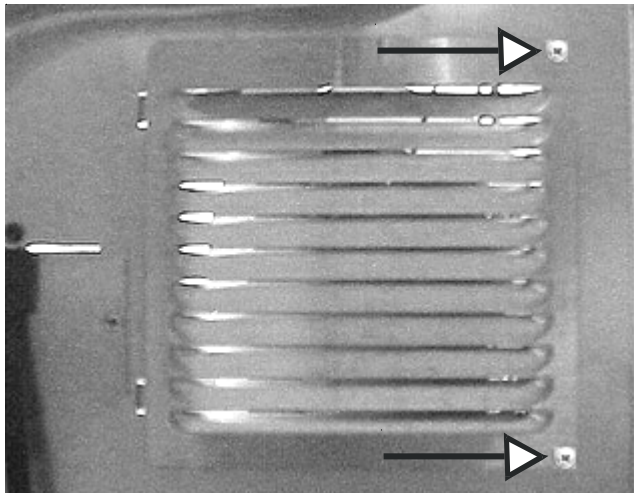

**Releasing the dryer belt:**

1. Remove the access panel.

2. Push the idler pulley to the left and slip the belt off the motor pulley.

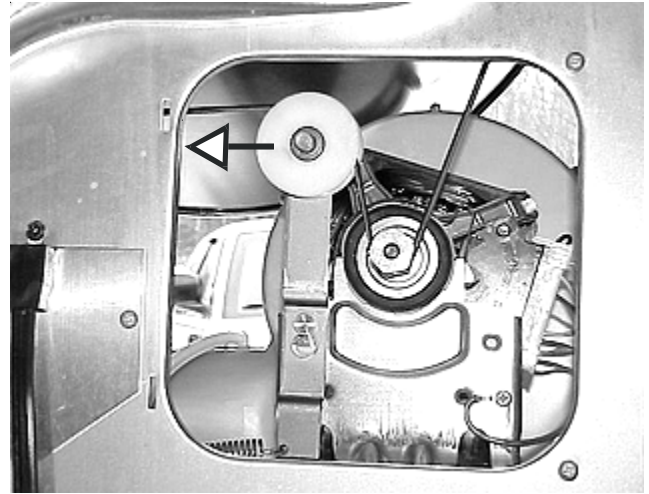

**Removing the idler pulley:**

1. Disconnect the laundry center from the electrical supply and remove the rear access panel.
2. Release the belt from the motor pulley and slide the idler pulley off.

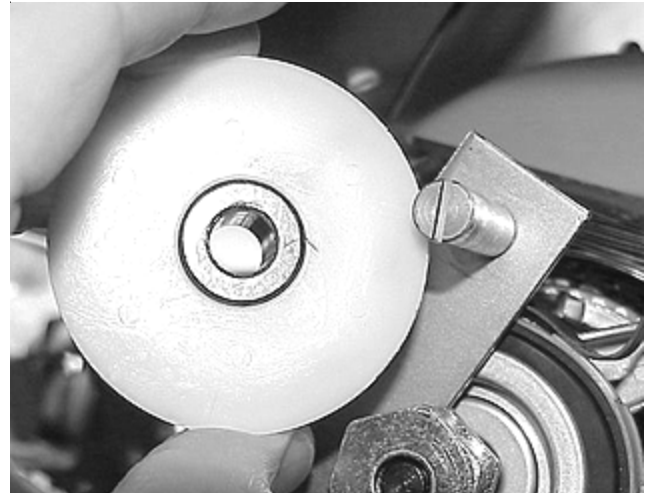

**Removing the idler pulley assembly:**

1. Disconnect the laundry center from the electrical supply and remove the rear access panel.
2. Release the belt from the motor pulley.



3. Release the idler spring from the dryer section base and lift the assembly off the shoulder pin.

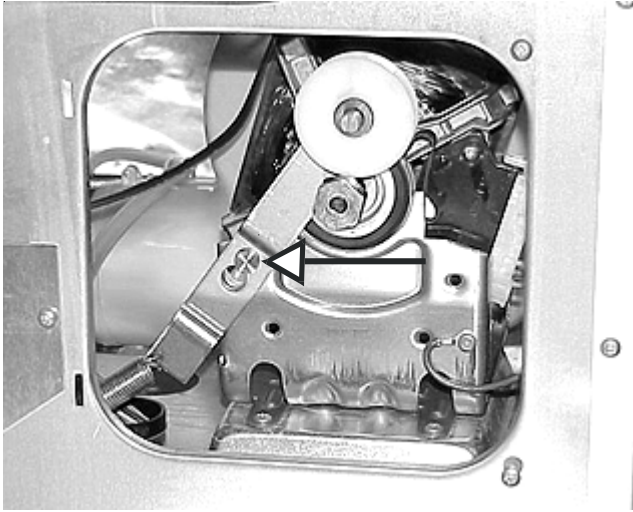

**Removing the belt:**

1. Disconnect the laundry center from the electrical supply and release the belt from the motor.
2. Remove the front panel.
3. From the front, slightly raise the front of the drum and slide the belt off.

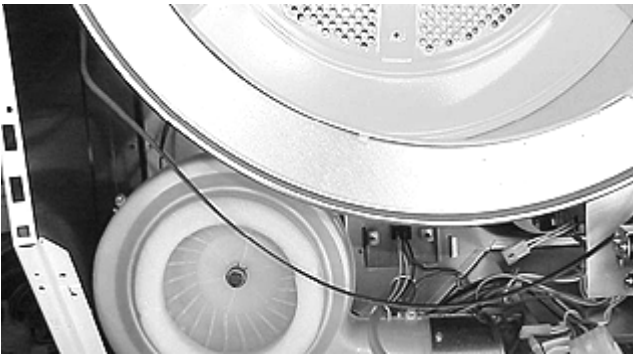

**Removing the control thermostat and thermostat heater:**

1. Disconnect the laundry center from the electrical supply, remove the access panel and heat shield.
2. The control thermostat and thermostat heater is mounted to the base plate of the dryer section.

3. Disconnect the wires from the thermostat and heater, remove the two screws holding the thermostat and heater to the base plate of the dryer.

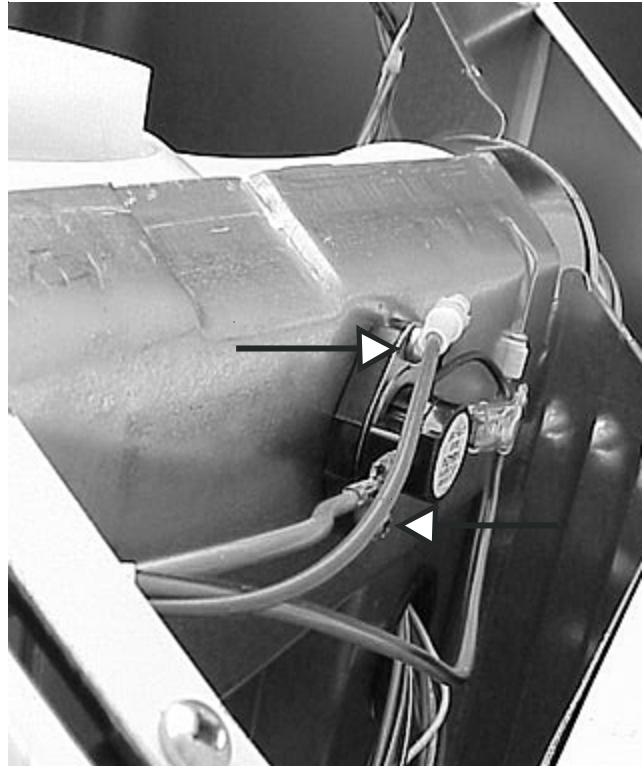

**Removing the sensor: (Gas dryers)**

1. Disconnect the laundry center from the electrical supply, remove the access panel and heat shield.
2. Open the console and disconnect the two wires from the sensor.
3. Remove the one screw holding the sensor to the combustion chamber.

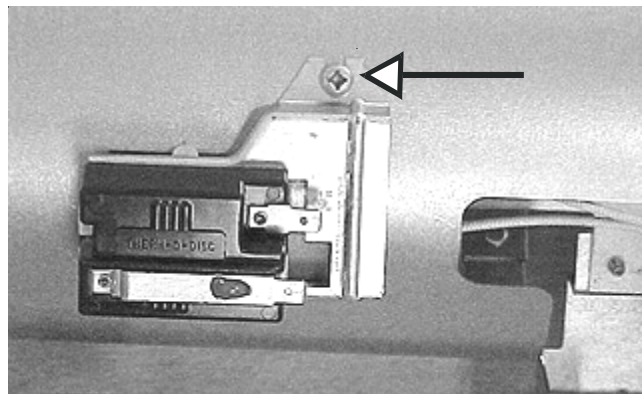

**Removing combustion chamber shield: (Gas dryers)**

1. Disconnect the laundry center from the electrical supply, remove the access panel and heat shield.

2. Remove the two screws holding the shield to the combustion chamber, the screw holding the shield to the burner bracket and lift the shield off.

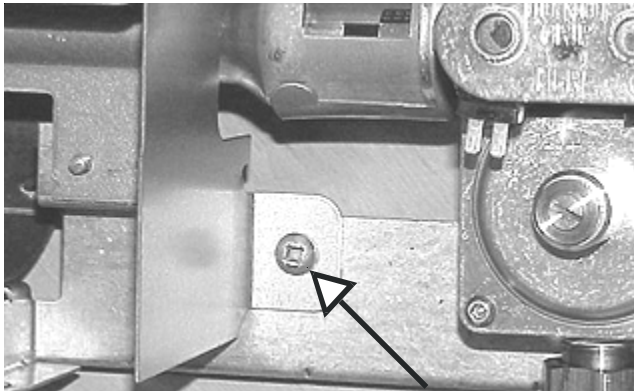
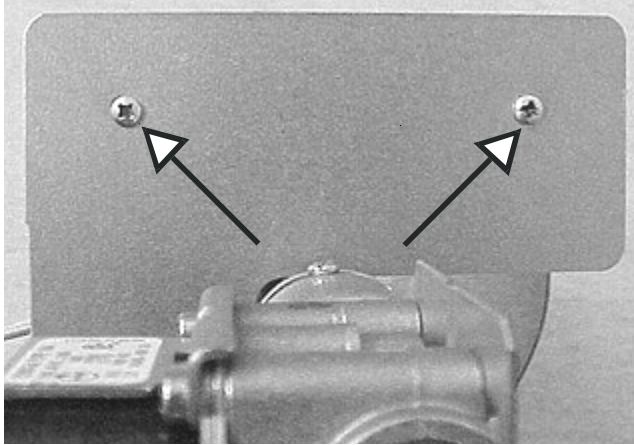

### Removing the burner: (Gas dryers)

1. Disconnect the dryer from the electrical supply and remove the front panel.
2. Unplug the igniter, remove the two screws holding the burner to the valve assembly bracket, and slide the burner into the combustion chamber to release the burner from the valve.

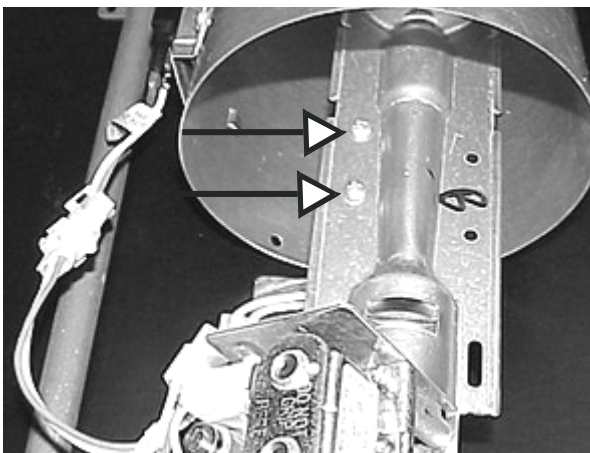

### Removing the ignitor: (Gas dryers)

1. Disconnect the laundry center from the electrical supply and unplug the igniter harness.
2. The igniter is held to the burner mounting bracket by a screw and a tab. Remove the screw and lift the igniter up to release the tab, then slide the igniter forward.

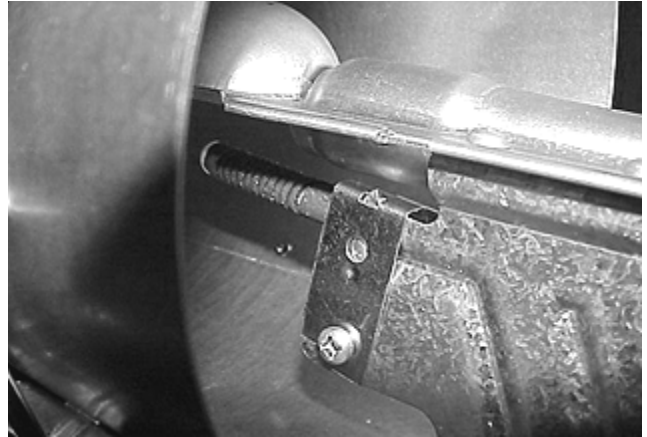

### Removing the gas valve coils: (Gas dryers)

1. Disconnect the laundry center from the electrical supply, remove the access panel and heat shield.
2. Disconnect the wires from the coils, remove the two screws holding the coil bracket to the valve base and lift the coils off.



### Removing the burner and combustion chamber assembly, manual shut off and the internal gas pipe: (Gas dryers)

1. Disconnect the laundry center from the electrical supply and turn the gas supply off.
2. Open the console, remove the access panel and heat shield.



- Remove the six screws holding the burner assembly and internal gas pipe to the dryer section base plate.

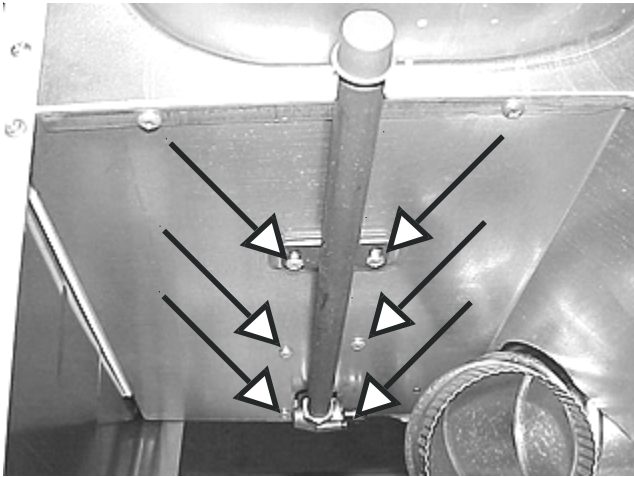

- Slide the assembly out the front.

**Removing manual shut off and internal gas pipe:  
(Gas dryers)**

- Disconnect the laundry center from the electrical supply, turn the gas supply off and remove the burner combustion chamber assembly.
- Using a 15/16 inch wrench disconnect the manual shut off from the pressure regulator valve assembly.

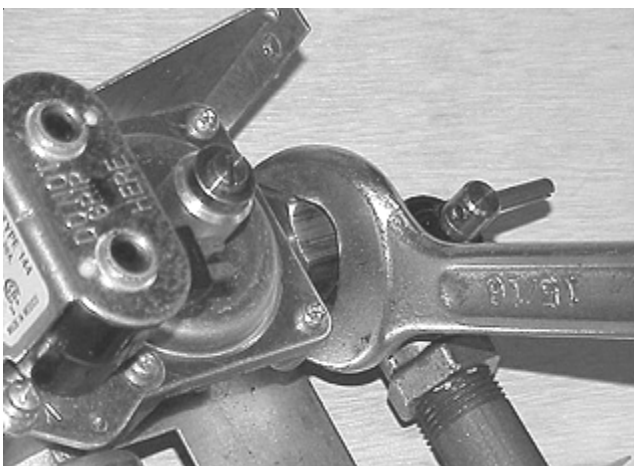

**Removing pressure regulator valve assembly:  
(Gas dryers)**

- Disconnect the laundry center from the electrical supply, turn the gas supply off and remove the burner combustion chamber assembly.
- Disconnect the manual shut off, remove the two

screws holding the assembly to the mounting bracket and pull the assembly back and out.

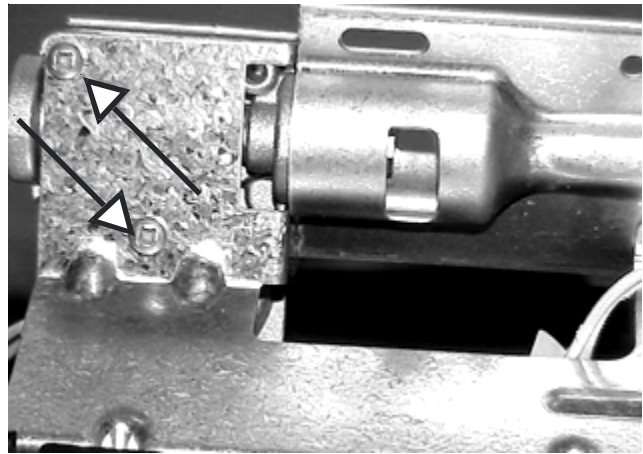

**Removing the combustion chamber: (Gas dryers)**

- Disconnect the laundry center from the electrical supply, turn the gas supply off and remove the burner combustion chamber assembly.
- Remove the combustion chamber shield and the 1 screw holding the combustion chamber to the mounting bracket.

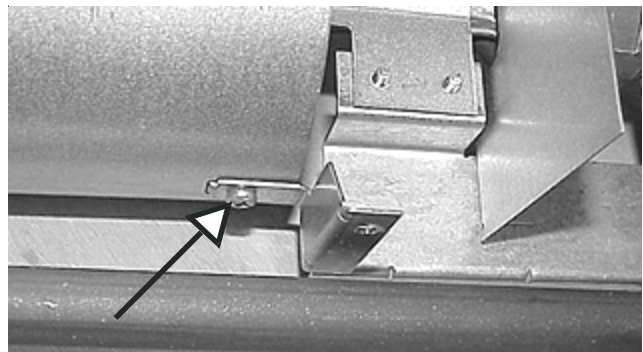

**Removing the dryer top panel:**

- Remove the ten screws holding the top panel to the front, back and sides.

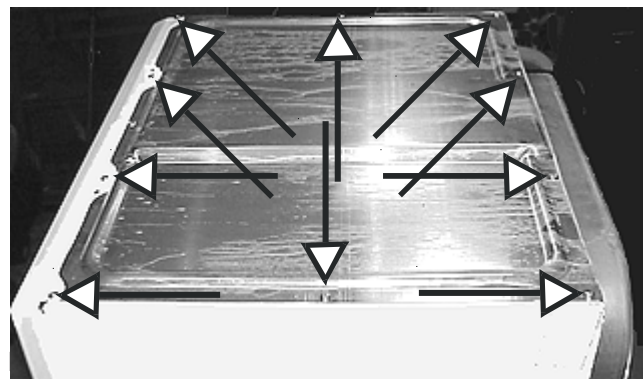



### Removing the vanes from the dryer drum:

1. Remove dryer top panel from the laundry center, and open the dryer door.
2. Rotate the drum until the vane is at the top, remove the two screws holding the vane to the drum and drop the vane into the drum.

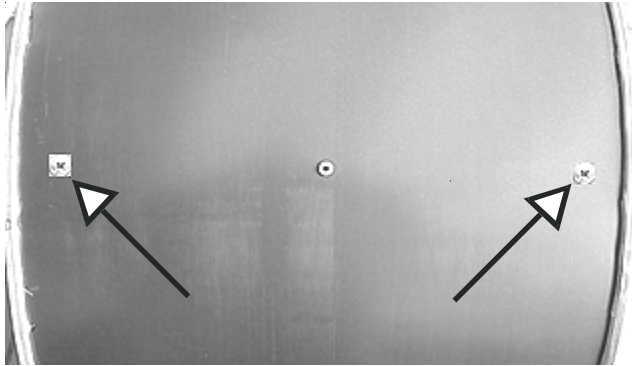

2. Remove the three screws from inside the drum holding the ball hitch to the drum.

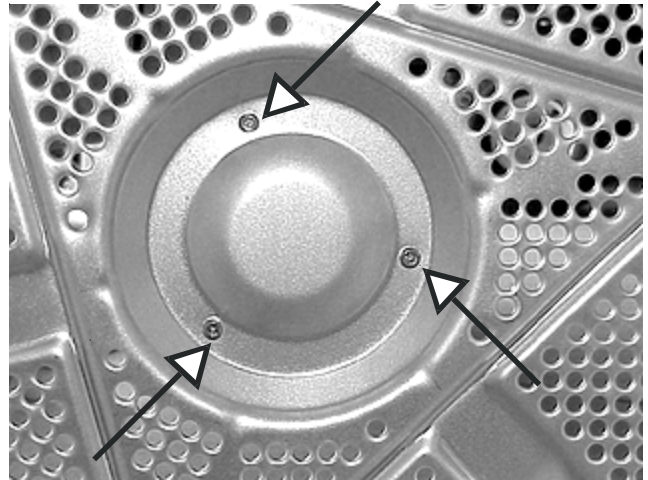

### Removing the dryer drum:

1. Disconnect the laundry center from the electrical supply and remove the dryer top panel.
2. Disconnect the dryer drive belt from the motor and remove the dryer front panel.
3. Raise drum to disengage the ball from the hitch and slid the drum out the front.

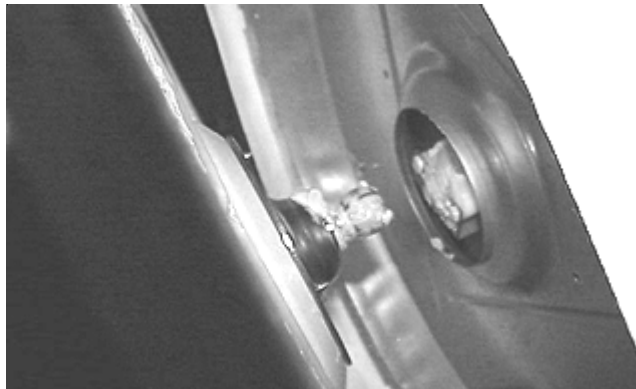

### Removing the teflon glides:

1. Disconnect the laundry center from the electrical supply and remove the drum.
2. Squeeze the tabs to release the glides.

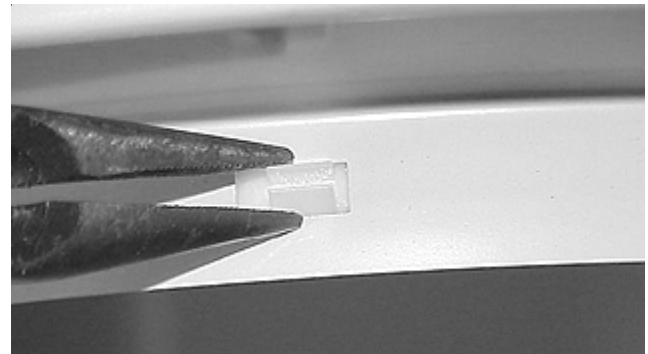

### Removing the ball hitch from the drum:

1. Disconnect the laundry center from the electrical supply and remove the drum.

### Removing the drum heat shield: (Electric dryers)

1. Disconnect the laundry center from the electrical supply and remove the drum.

- Remove the three screws holding the shield to the rear of the drum.

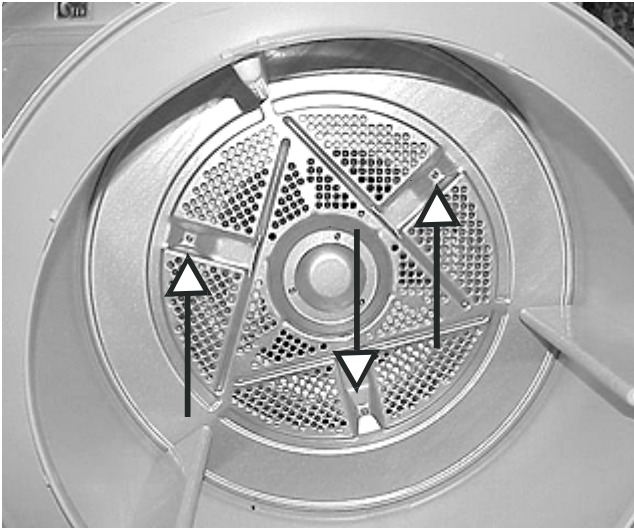

**Removing the hitch:**

- Disconnect the laundry center from the electrical supply and remove the drum.
- Using a 5/16" nut driver, remove the two screws holding the hitch to the rear panel while holding the large tinnerman clip from the rear of the laundry center.

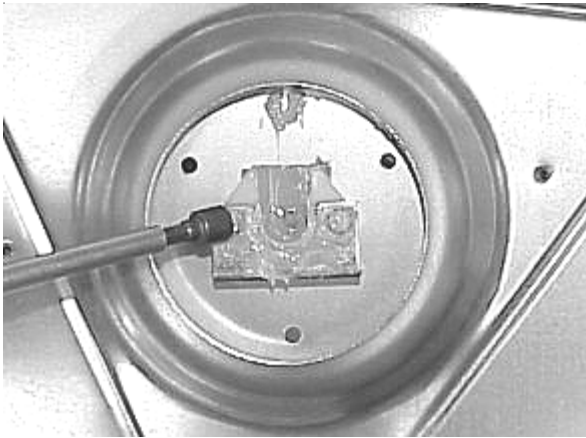

**Note:** Do not lose the grounding ball or the tinnerman mounting clip from the rear of the dryer.

**Removing the high limit thermostat:**

- Disconnect the laundry center from the electrical supply and remove the drum.
- Disconnect the two wires and remove the two screws holding thermostat to the rear heat shield.

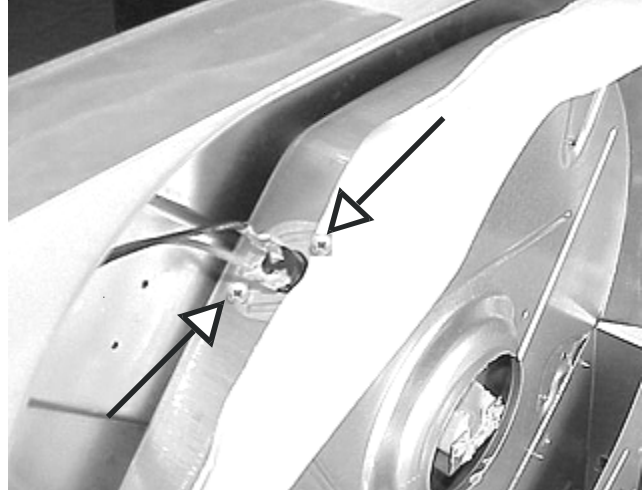

**Removing the thermal limiter: (Electric dryers)**

- Disconnect the laundry center from the electrical supply and remove the drum.
- Disconnect the two wires and remove the two screws holding limiter to the rear panel.

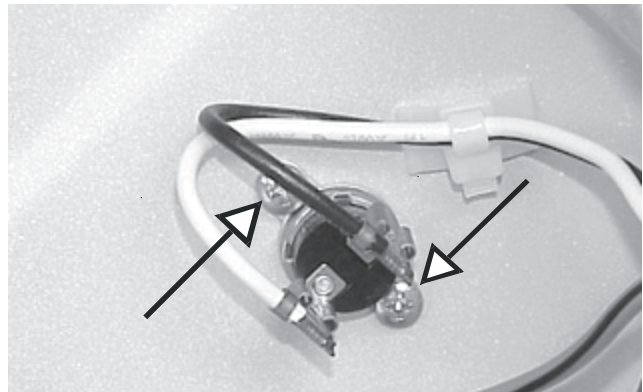

**Removing the heating element assembly: (Electric dryers)**

- Disconnect the laundry center from the electrical supply and remove the drum.

2. Disconnect the two wires from the heating element.
3. Remove the high limit thermostat.
3. Disconnect the wires from the high limit thermostat and remove the three screws holding the heat shield to the rear panel of the laundry center.

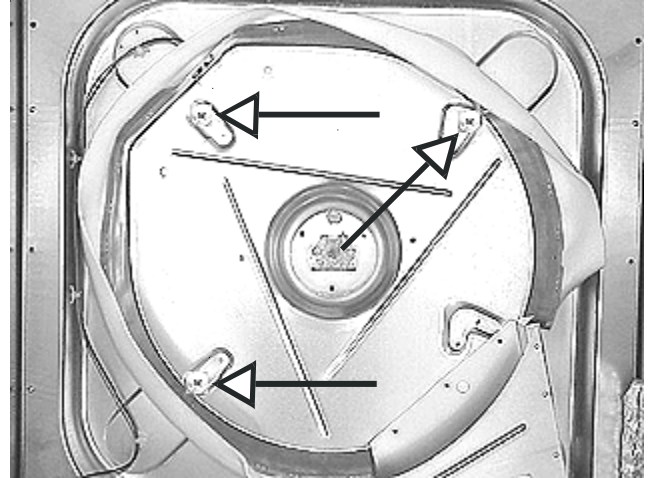
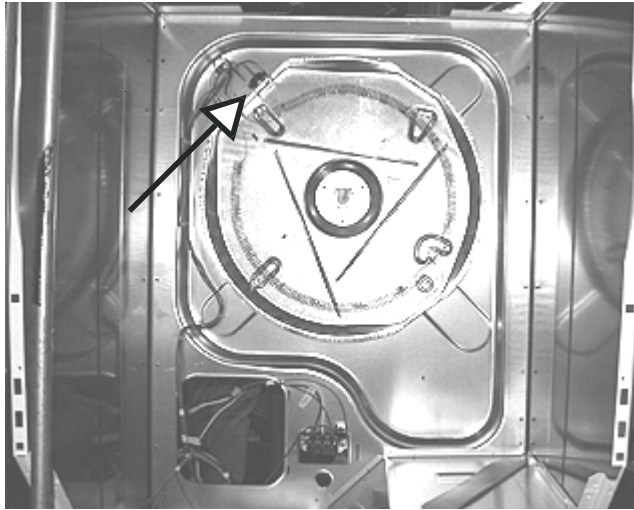

4. Remove the four screws securing the heating element assembly to the rear of the cabinet.

4. Lift the shield and duct out of the laundry center and remove the three screws holding the duct to the heat shield.

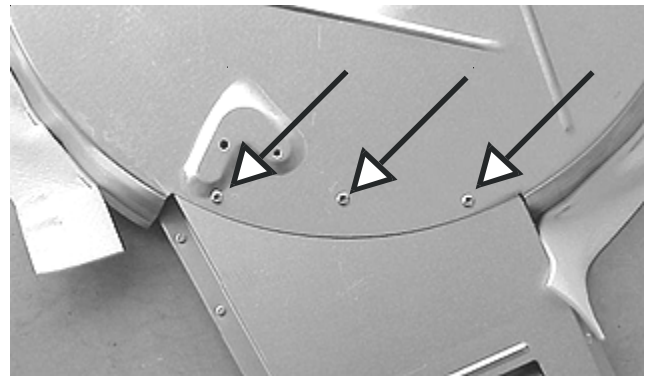
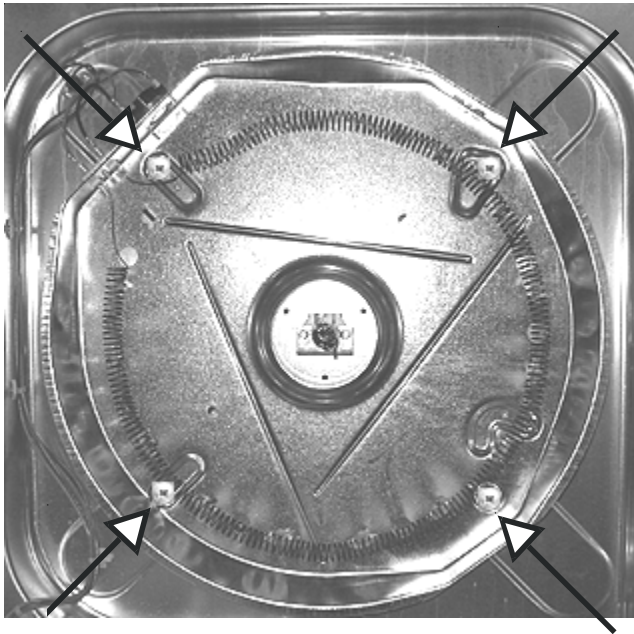

#### Removing the duct and heat shield: (Gas dryers)

#### Removing the blower and motor assembly:

1. Disconnect the laundry center from electrical supply and remove the drum.
2. Remove the burner combustion chamber assembly.

1. Disconnect the laundry center from the electrical supply and remove the drum.
2. Remove the control thermostat and heater, unsnap the pressure switch hose and the screw holding the blower housing to the vent pipe.

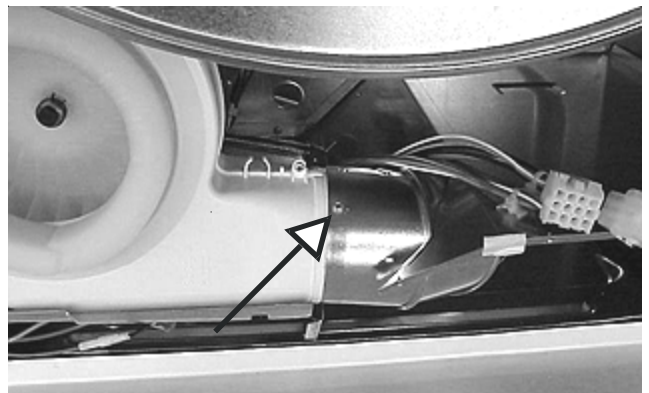



3. Unplug the harness from the motor, remove the idler pulley assembly and disconnect the ground wire from the motor.
4. Remove the two screws holding the motor mounting plate to the dryer base.

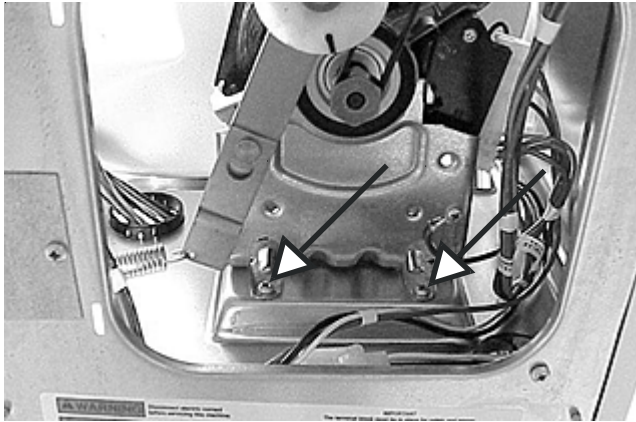

5. Lift the front of the assembly and slide it backward to release the motor mounting plate from the dryer base.

**Disassembling the blower and motor assembly:**

1. To remove the front half of the blower assembly, remove the six screws holding the front half to the rear half of the blower assembly.

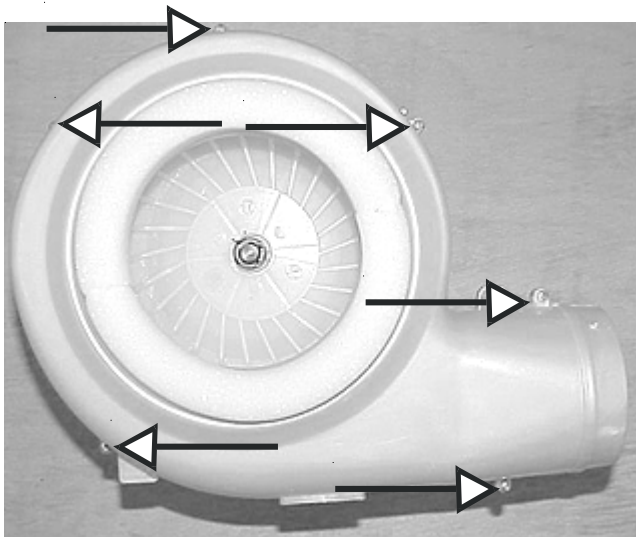

2. The blower wheel can be removed by removing the clamp holding the blade to the motor shaft.



3. Using two small common screwdrivers, release the blower wheel from the notch in the motor shaft and pull the blower wheel off.



4. With the blower wheel removed, the rear half of the blower housing and the motor can be removed.
5. To remove the rear half of the blower assembly, remove the three screws holding the housing to the motor mounting bracket.

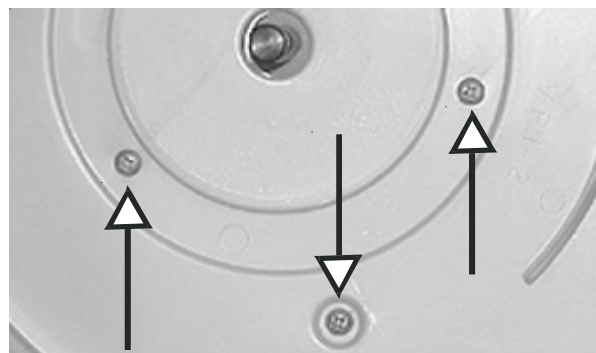

6. With the fan blade removed, the motor can be removed from the motor mounting bracket by releasing the two hold-down brackets, one at the front and one at the rear.

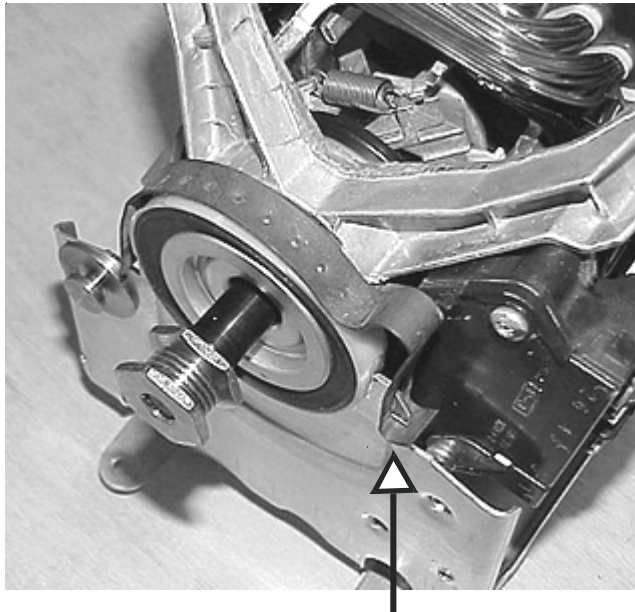

**Removing the motor and blower assembly base:**

1. Disconnect the laundry center from the electrical supply, remove the motor and blower assembly and disconnect the internal vent duct.
2. Remove the screw holding the base to the side panel.

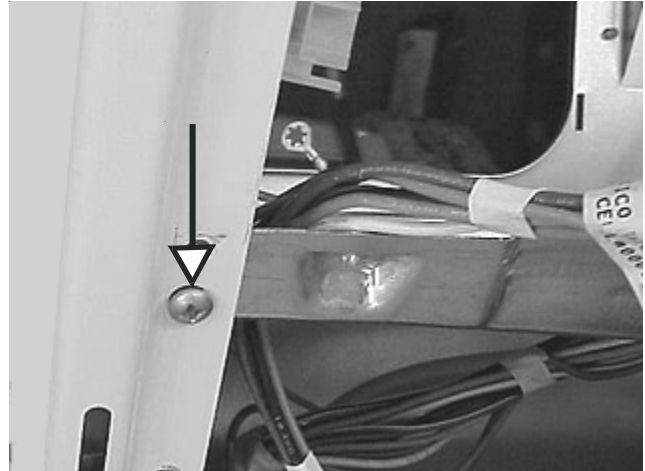

**Removing the internal vent duct:**

1. Disconnect the laundry center from the electrical supply and remove the drum.
2. Remove the screw holding the duct to the blower assembly and the screw holding duct to the base plate.

3. Remove the two screws holding the base to the rear panel.

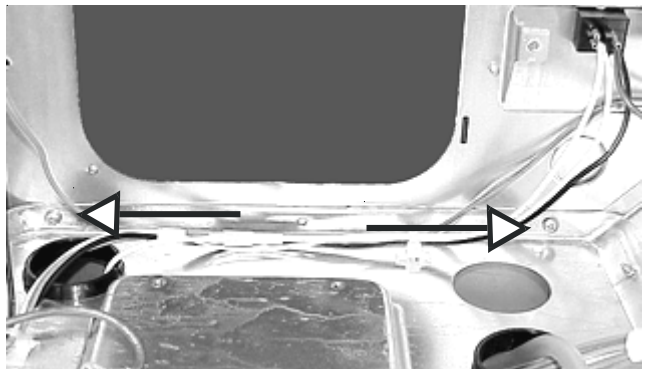
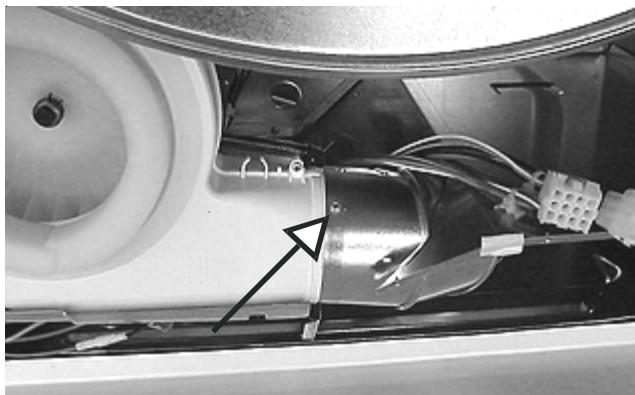

3. Remove the three screws holding the base to the burner base.

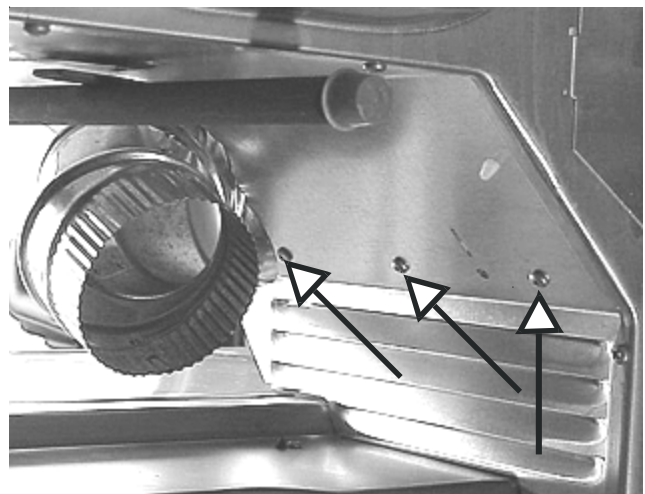



**Removing the burner assembly base: (Gas dryers)**

1. Disconnect the laundry center from the electrical supply and remove the burner assembly.
2. Remove the screw holding the base to the side panel.

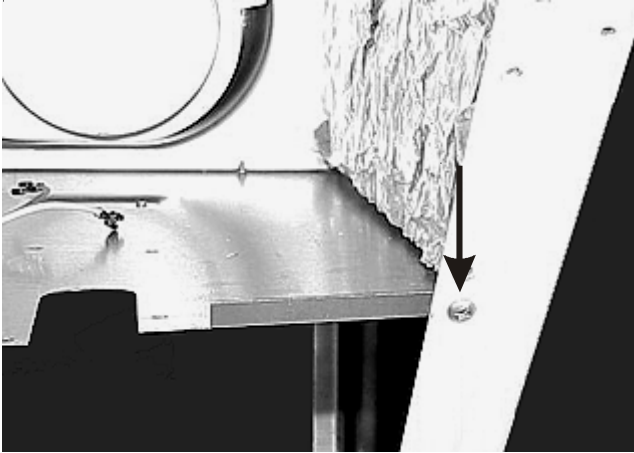

3. Remove the three screws in the front holding the side panel to the dryer section base.

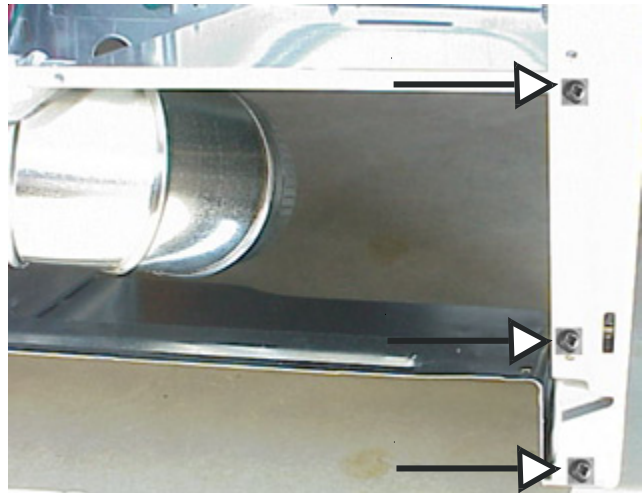

3. Remove the two screws holding the base to the rear panel and the three screws holding the base to the motor and blower assembly base.

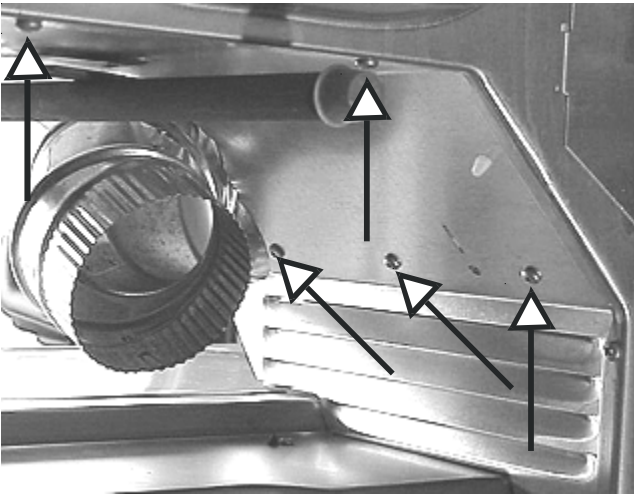

4. Using a 3/8 " socket, remove the two bolts holding the side brace to the washer panel.

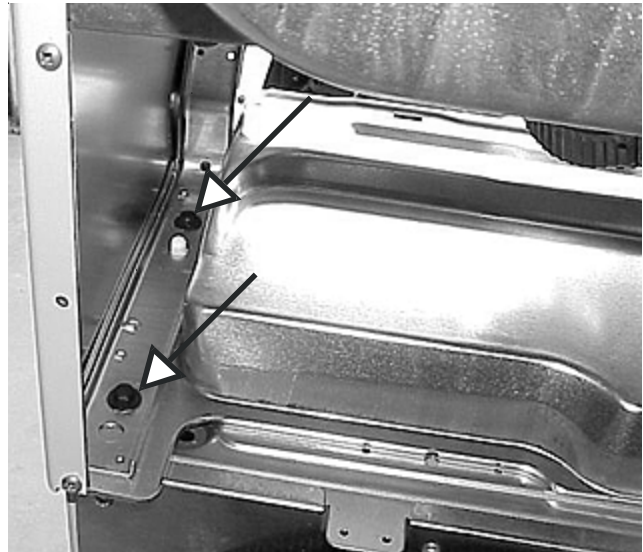

5. For the rear lefthand bolt, use an extension and go through the hole for the wires.

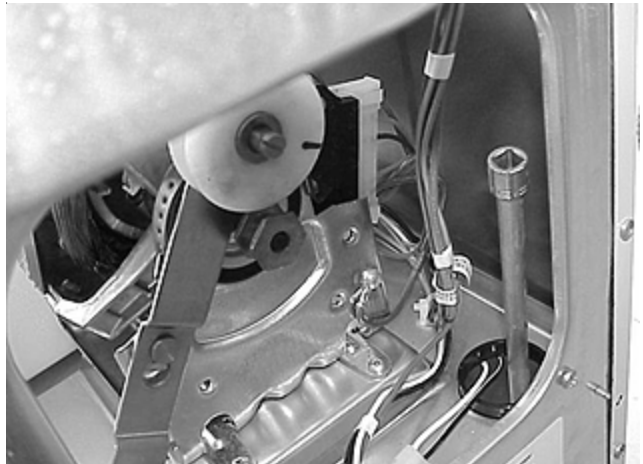

**Removing the dryer section side panels:**

1. Disconnect electrical power and remove the front access panel, heat shield, dryer front panel and washer top.
2. When removing the lefthand side panel, remove the drum and blower assembly.



- Remove the seven screws from the rear, the two remaining screws from the top and lift the panel off.

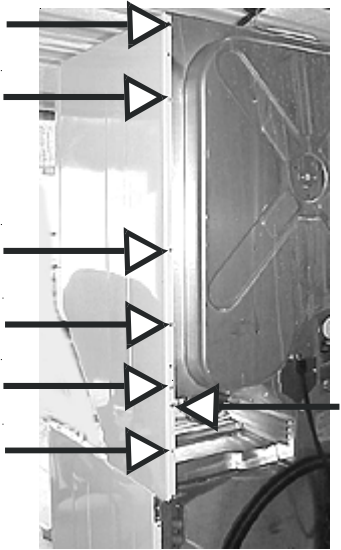

- Remove the rear access panel, disconnect the washer power harness and pull the harness into the washer section.

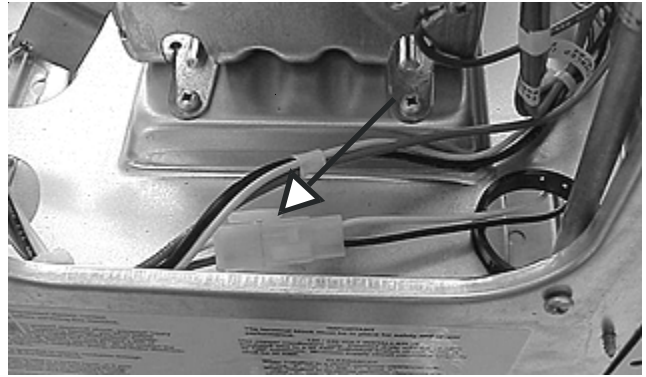

- Unclip the green ground wire and pull it into the washer section.

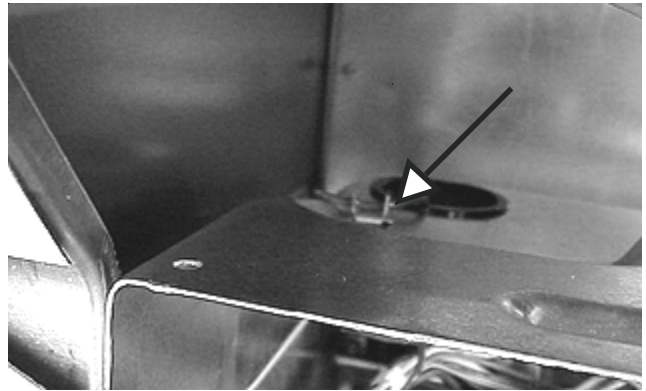
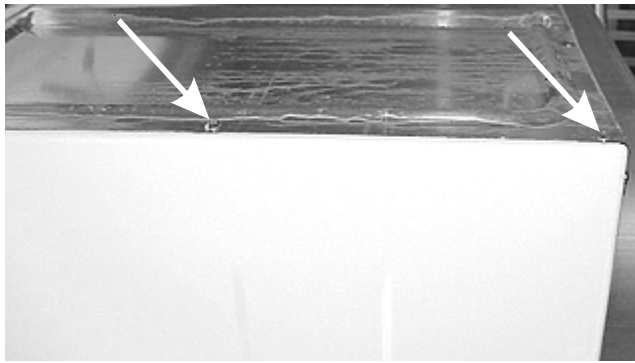

### Removing the dryer section:

- Disconnect power, disconnect gas (if gas dryer), disconnected the vent and move the laundry center out from the wall.
- Remove the front access panel, control panel, heat shield and washer top.
- Release the two wire ties holding the washer timer harness to the motor and blower assembly base and pull the harness into the washer section.

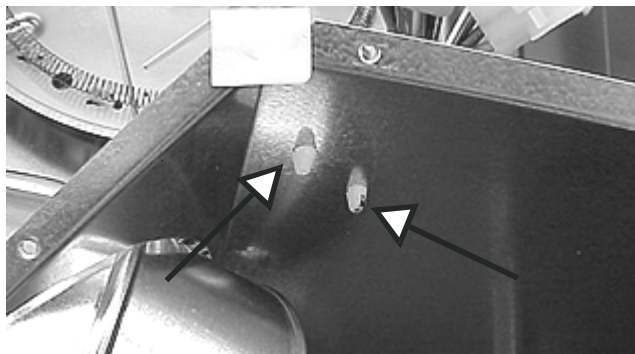

- Remove the four bolts, two on each side, holding the dryer section to the washer section and lift the dryer section off.

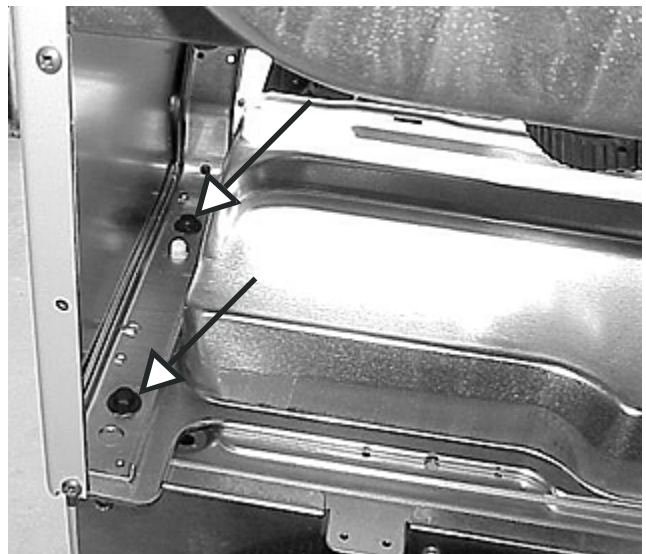

Note: If you wish to reduce the weight of the dryer section, remove the front panel with door, top and drum.

**Removing the detergent drawer:**

1. Slide the safety latch lever to the right and pull the drawer out until it hits the stop.

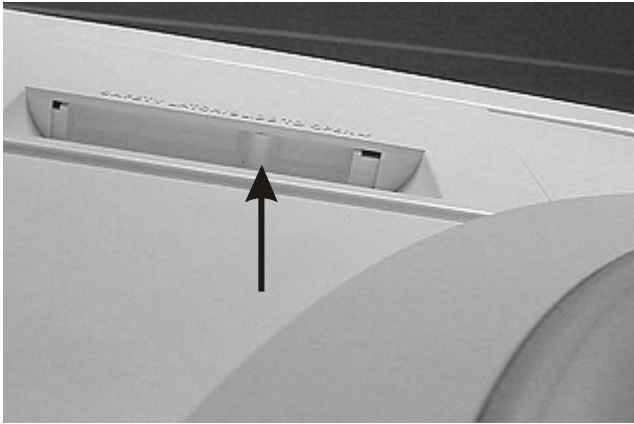

2. Push down on the release tab and pull the drawer the rest of the way out.

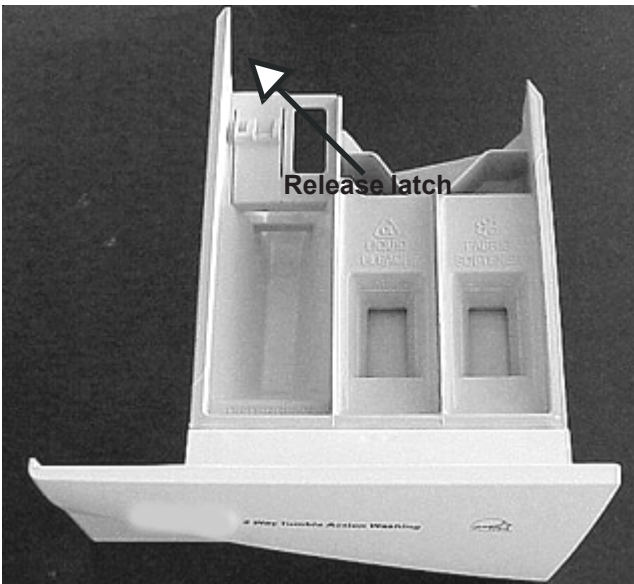

**Detergent drawer disassembly:**

1. Remove the drawer from the laundry center.

2. The liquid bleach and fabric softener inserts lift off. When reinstalling, be sure to seat them properly and in the correct location.

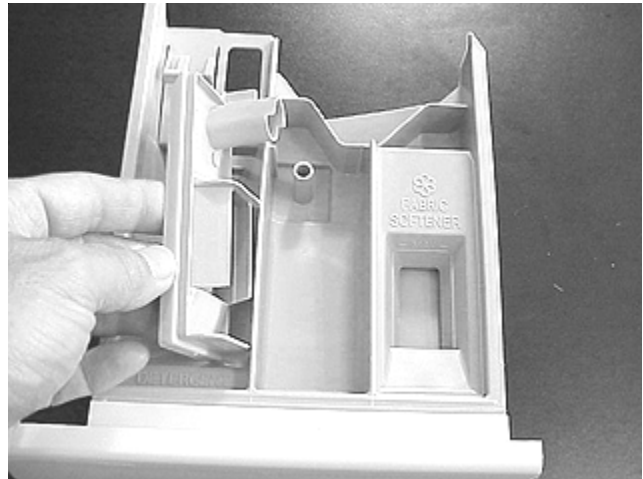

3. To remove the drawer front, release the three tabs and pull the drawer front away from the body. When replacing the drawer front always remember to transfer the reed switch magnet.

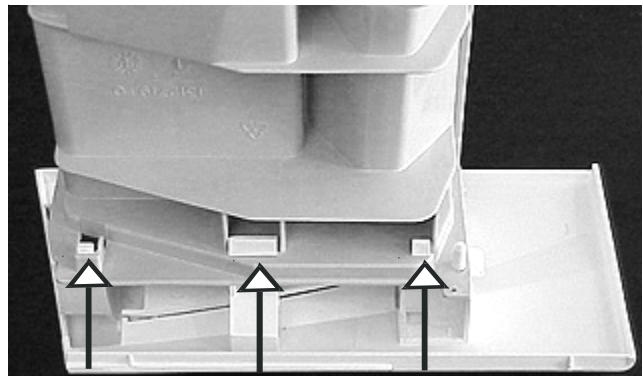

**Release the three tabs**

4. To remove the safety latch lever, compress the spring by moving the lever completely to the left and lift the lever out.

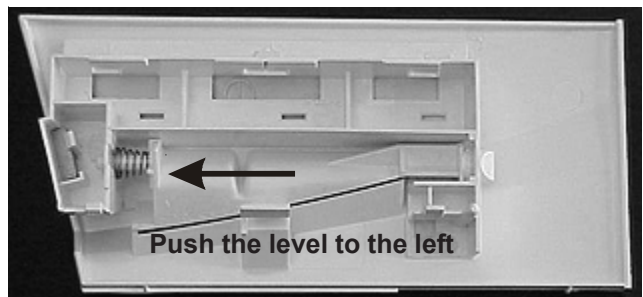

5. To remove the magnet, pull the tab to the right.

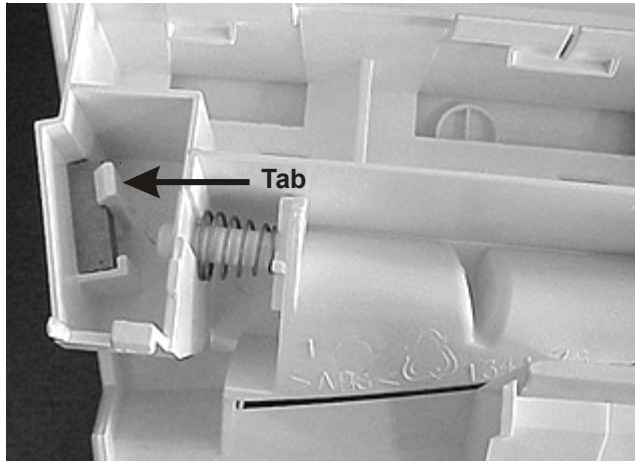

#### Removing the washer section top panel:

1. Remove the dryer section access panel, and pull the top forward to disengage the front hold-down brackets.
2. Release the ground wire and lift the top off.



#### Removing the top panel spacers:

1. The spacers are slid onto the two rear corner of the top panel.
2. To remove either spacer, pull the top panel forward and pull the spacer off the top panel.

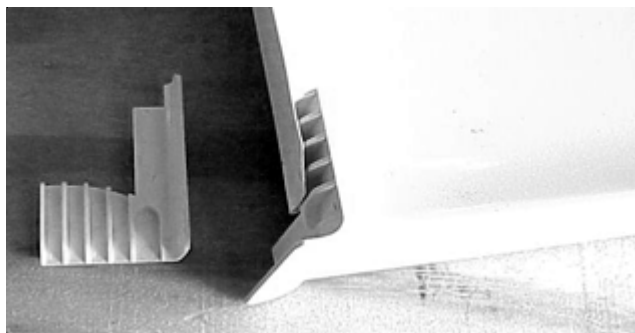

#### Removing the washer section upper front panel:

1. Disconnect the washer from electrical supply.
2. Remove the top panel and detergent drawer.
3. Remove the one screw behind the detergent drawer holding the top front panel to the top front mounting panel.

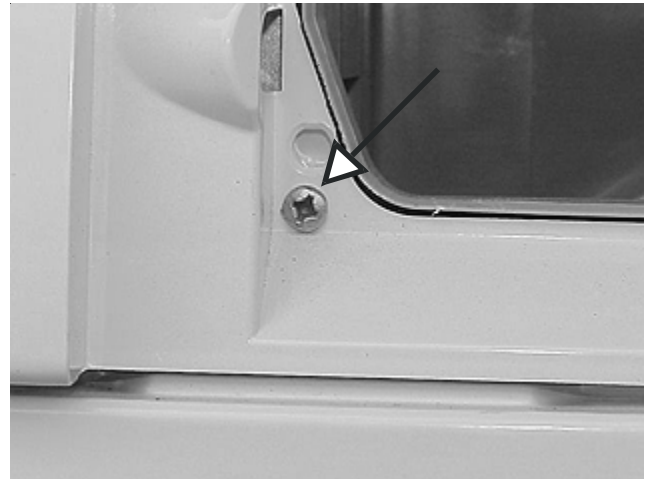

4. Remove the five screws from the control mounting plate holding the control panel to the mounting plate. Two on the right side,

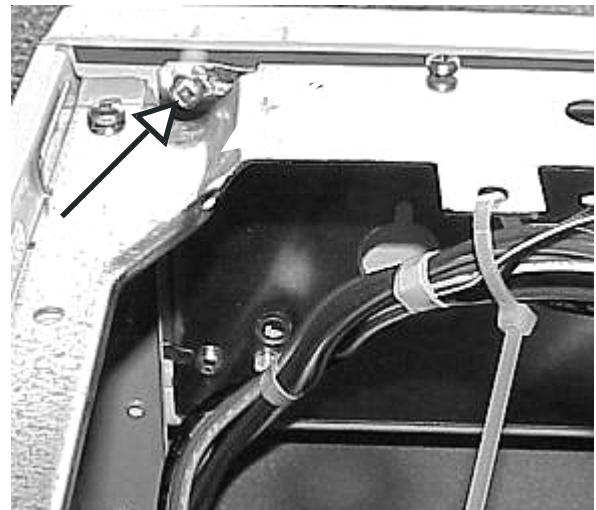



two in the center,

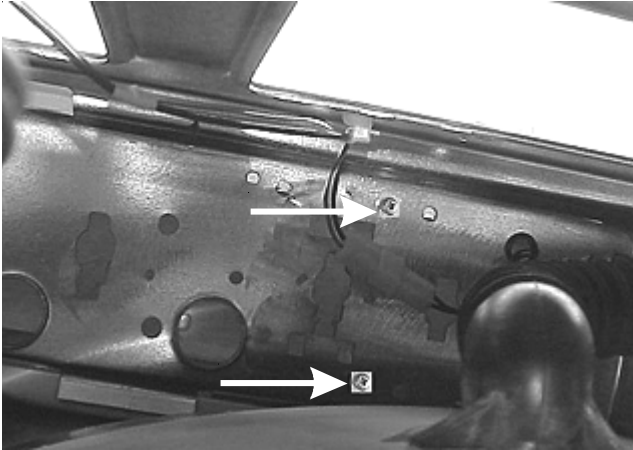

and one on the right side.

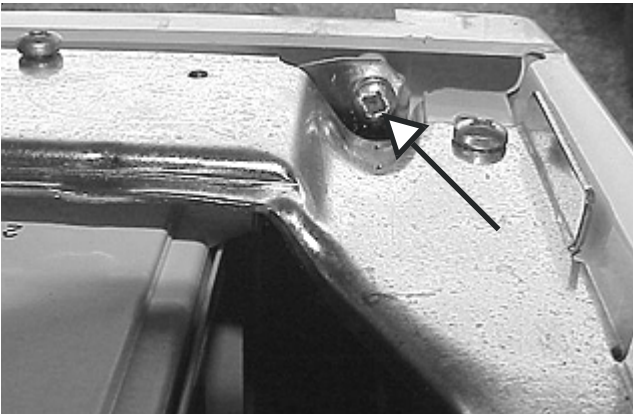

5. Pull the control panel forward and unplug the reed switch.

#### Removing the reed switch:

1. Disconnect the laundry center from the electrical supply.
2. Roll the console forward.

3. Unplug the reed switch harness from the control and unplug the reed switch from the console.

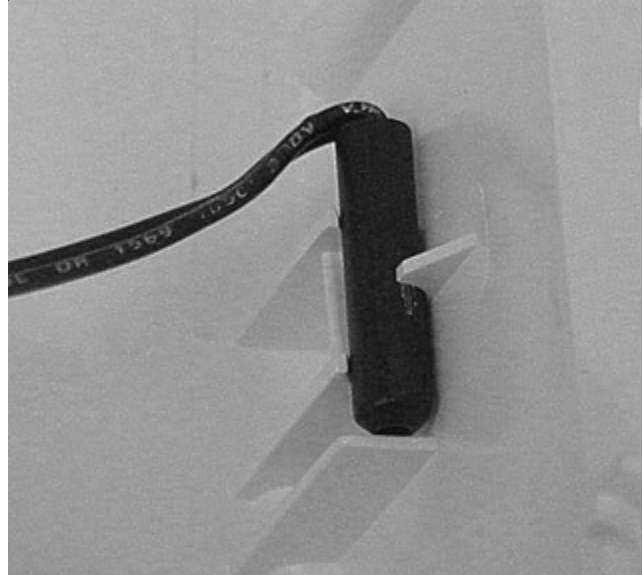

#### Removing the front service panel:

1. The front service panel is held in place by two nylon pins at the top and two 1/4" hex screws located at each bottom corner.

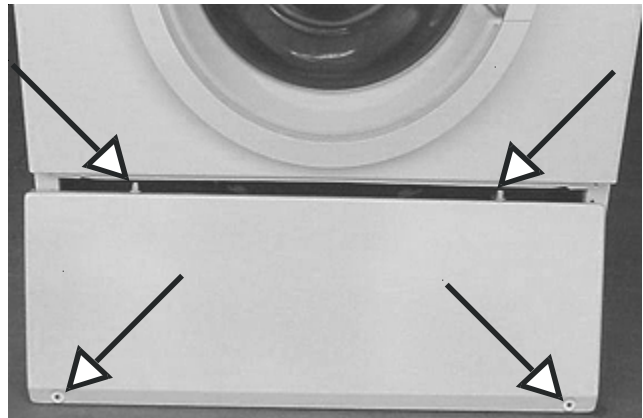

2. Remove the two 1/4" hex screws located at each bottom corner. Pull down and forward.

### To remove loading door and hinge:

1. Remove the door by removing the (2) screws holding the hinge to the washer front.

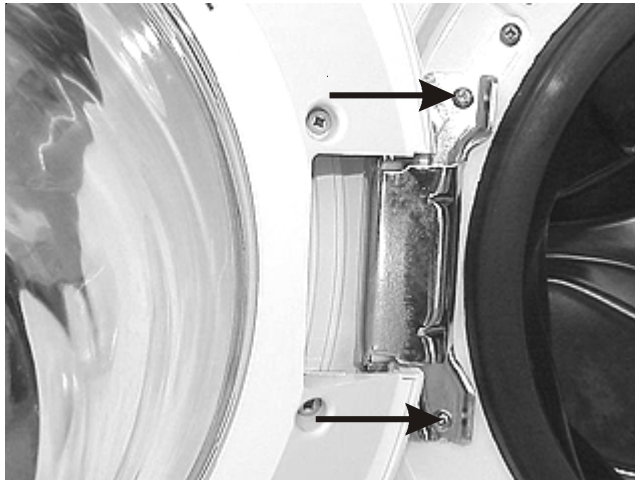

2. Lift the door and hinge up to disengage the hinge tab from the washer front and remove the door and hinge.

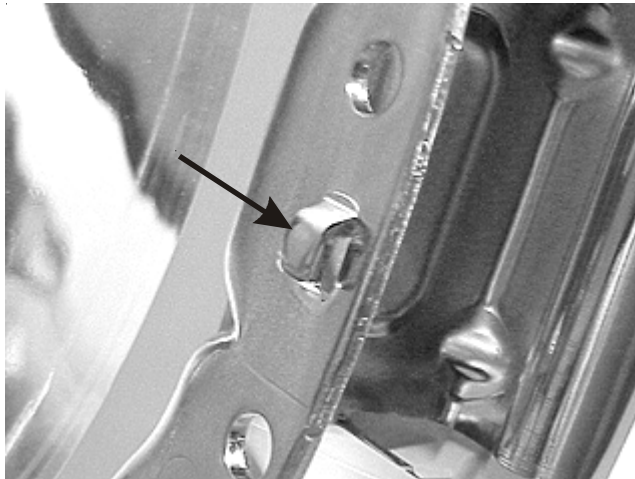

### Disassembling the door:

1. Remove the (4) screws holding the two half of the door together (2) at the hinge, (1) at the top and (1) at the bottom .

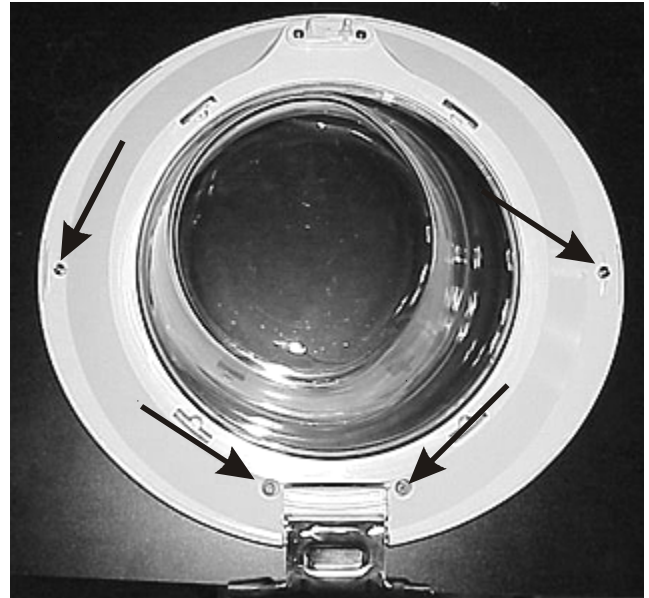

3. Using two flat bladed screwdrivers, place one in the cavity by the latch and one in cavity by the top screw and gently pry the cover off.

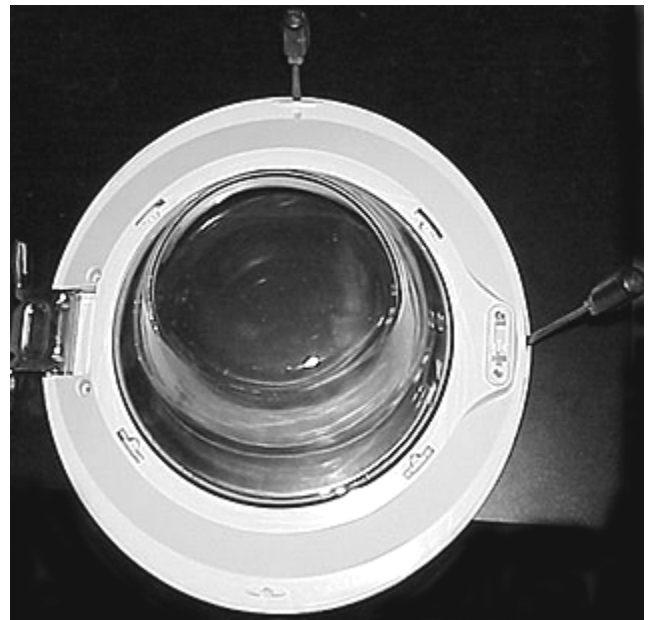

4. Remove the hinge by removing the (2) screws holding the hinge to the inner door panel.

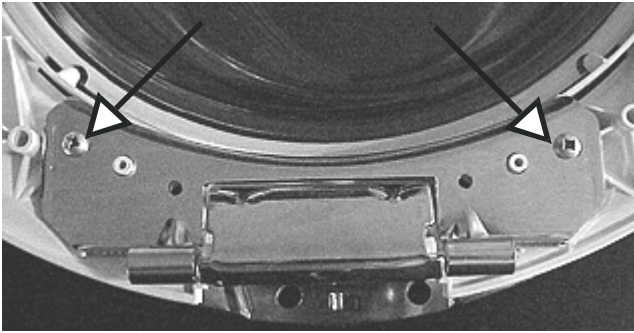

4. The glass is held in place by four molded tabs in the rear door cover. To remove the glass, grab the edge of the cover by the tab and twist it away from the glass.



5. Reinstall the glass into door frame by pressing into place. Note locating notches on glass which ensures correct position.

**To remove door strike:**

1. Open loading door.

2. Remove (2) screws which secure strike to inner door panel.



**Removing the door safety switch:**

1. Disconnect the laundry center from the electrical supply.
2. Remove top panel and front service panel.
3. Reaching in from the top, unplug the three connectors from the door switch.





4. Reach up from the bottom and hold the switch while removing the two screws from the front. Then drop the switch assembly out the bottom.

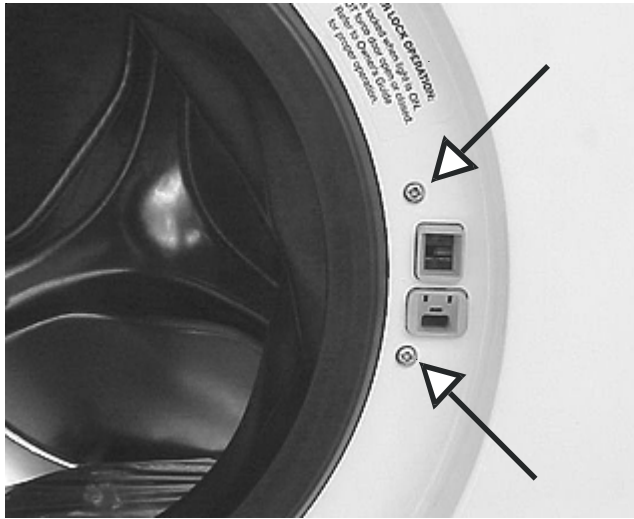

**NOTE:** The connectors can be disconnected from the bottom, but it is more difficult.

#### Removing the bellows (door boot):

1. If the machine is positioned in such a way that it would be difficult to move, you will be better off leaving it where it is. However, if it is possible, it is easier to do this job if the machine can be leaned back against a wall protect the wall with cloth or rug). By leaning it back, the tubs will hang back from the front panel and you will have increased space to work. If leaning it back is not possible, then a 6 or 8 inch block of wood can be wedge between the front panel and the tub to hold the tub back out of the way.

2. The boot is attached to a lip around the perimeter of the opening on the front panel with a wire spring clamp. Insert a small screwdriver between the spring and the boot at the six o'clock position. Gently pull down and out on the spring. Continue to work the wire clamp off the boot.



3. Once the boot is loose from the front panel, push it into the opening of the tub and out of the way.



At this point, if the machine is not leaning back, take your block of wood and while pushing back on the tub through the opening, wedge the block between the front panel and the tub about ten inches to the bottom - right of the opening. This will afford you more space to work with the boot.

4. The boot is still attached to the water inlet duct that is located just inside the front panel at the upper left corner from the opening. This is where the water, soap, bleach and fabric softener enter the tub. To remove (and later on, reattach) the clamp holding this in place on the end of the duct make a tool from a three inch piece of 3/8 inch soft copper tubing by flattening one end somewhat, so that it can be slipped over the twisted ends of the clamp.



Twist the tube counterclockwise to open the wire clamp. Remove the clamp and pull the boot free from the duct.

5. Using both hands, grab onto the boot at the top of the opening to the tub and pull downward and toward you with slow steady pressure. As the boot is pulled free from the outer lip of the tub (at the top), the coiled spring that holds the boot from the groove

behind the lip around the opening to the front shell will become visible. You can either continue pulling on the boot until it comes off or you can hook the spring (with a piece of coat hanger fashioned into a hook) and pull it off and then pull the boot off separately.

#### Reinstalling or replacing the boot:

1. The boot has a lip that will have to be folded into the groove behind the lip on the front tub shell. To start, examine the boot and locate the groove in front of the lip that corresponds to the similar lip and tab on the tub shell.
2. Using some liquid dishwasher soap sparingly lubricate this groove on the boot to make it easier to slip onto the lip of the tub shell.



3. Once the groove in the boot is lubricated with soap, locate the arrow that is located on the top of the boot (located to the right of the extrusion that slips over the duct). This arrow must point up when the boot is installed.

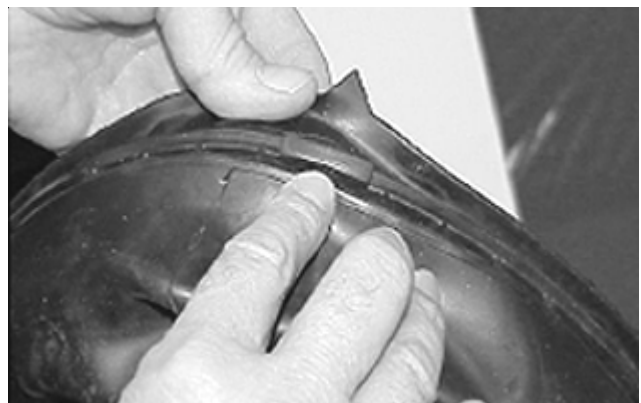

4. With the boot in one hand and with the other hand spreading the lip and groove (on the boot near the arrow), force the lip into the groove behind the lip at the top of the opening on the tub shell.



5. With one hand holding the boot so it does not slip off, use the other hand to continue spreading the lip and groove of the boot further to the right. In this way you continue this action 360 degrees around until the boot is mounted onto the front tub.



6. Installing the spring. Included in the replacement boot kit is a set of three spacers.

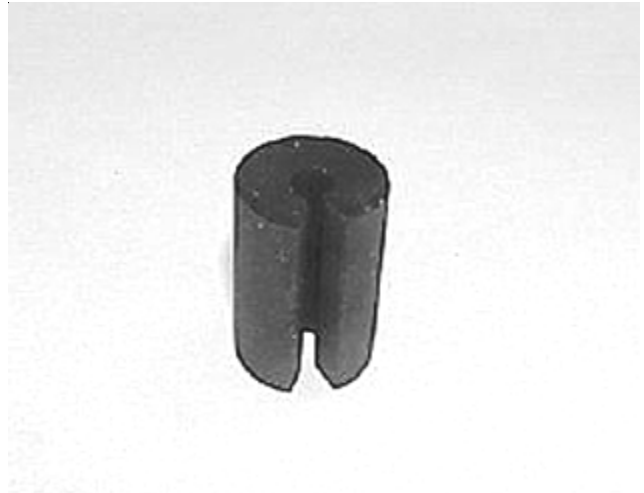

These spacers are to be used to hold the spring in place in the groove on the outside perimeter of the boot. As it will take both hands to stretch this spring into place, these spacers will prevent the spring from popping out when you let go of it to use both hands to stretch it further around the boot. Begin by pushing the spring down into the groove just forward from where the boot contacts the front tub shell at about the 12 o'clock position. While holding the spring in place with one hand, use the other to tightly wedge the spacer above it, between the spring (in its groove) and the weight ring above it.



7. Working to the right, push the spring down into the groove. Once the spring has been installed about 90 degrees around the opening from the first spacer,



8. Continue working your way around until you reach 180 degrees from the first spacer. Install the third spacer.
9. The spring will be extremely tight now.

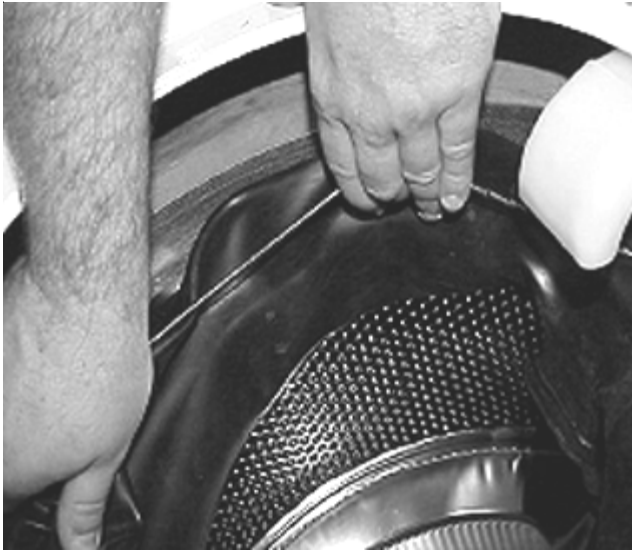

Once you have gone more than half way around, the spring will be easier to roll into the rest of the groove. When you have the spring in place, make sure to remove the three spacers.

10. Replace the boot extrusion back onto the duct and pull it up over the ridge on the duct near the top of the opening.



Reinstall the clamp in such a way that the clamp sits between the ridges on the extrusion and above the ridge on the duct. Snap the clamp closed with the copper tubing tool.

11. Before attaching the new boot to the front panel, clean the surface of the front panel with alcohol or household cleaner. This step is needed to ensure the new boot will lay flat against the front panel.
12. Remount the boot onto the front panel making sure the boot is not wrinkled. If large wrinkles exist, this may pool water in the boot and dribble onto the floor when the door is opened. If this is the case, pull it loose from the front panel and remount it slightly more clockwise or counter clockwise as needed.



13. Insert the wire spring clamp into the groove at the top of the boot. Work the clamp into the groove all the way around the boot making sure the clamp is oriented to the 6 o'clock position. Close the door to assure proper sealing of the boot to the door. Run the washer to check for leaks.



### Removing the water inlet duct:

1. Disconnect the laundry center from the electrical supply.
2. Remove the top panel and detergent dispenser cavity.
3. Disconnect the boot from the duct.
4. Remove the two screws holding the duct to the front panel.



5. Pull the duct to the rear and disconnect the inlet hose.

### Removing the detergent dispenser solenoid assembly:

1. Disconnect the laundry center from the electrical supply.
2. Remove the top panel from the washer.
3. Unplug the wires and disconnect the hoses from the dispenser solenoid assembly.

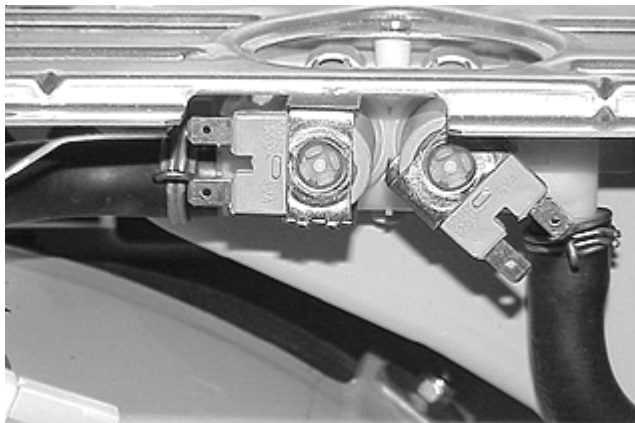

4. Remove the two screws holding the solenoid assembly to the detergent dispenser cavity and pull the assembly back.

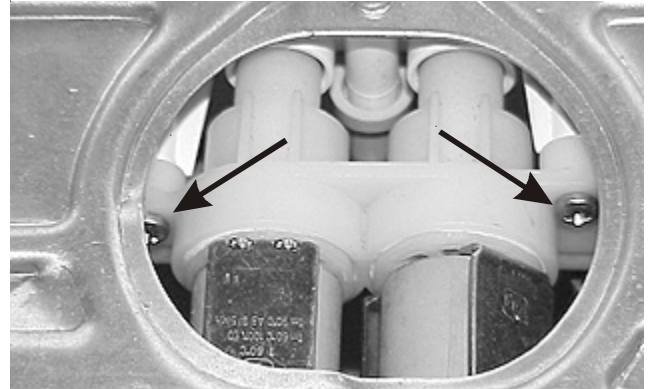

### Removing the detergent cavity assembly:

1. Disconnect the laundry center from the electrical supply.
2. Remove the top panel and the top panel front mounting brackets.
3. Remove the washer section upper front panel.
4. Disconnect the vent hose.

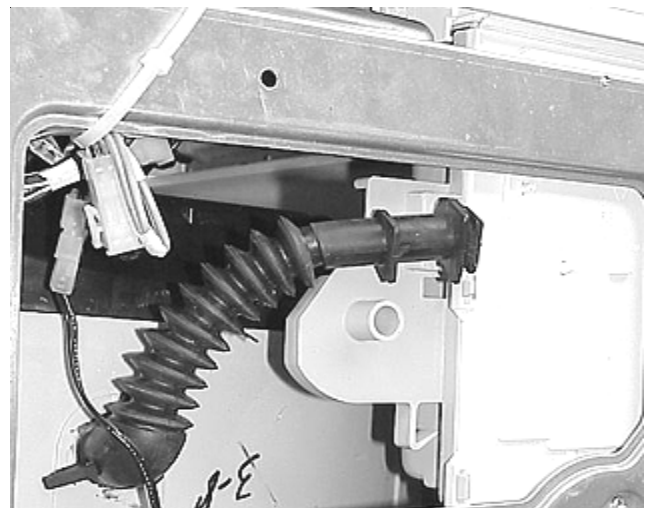

5. Remove the two screws securing the suspension spring retainers.
6. Remove the suspension spring retainers.



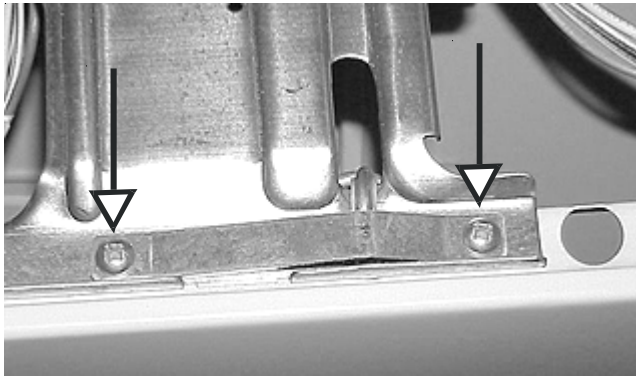

7. Remove the detergent dispenser solenoid assembly.

8. Remove the one screw from dispenser assembly.

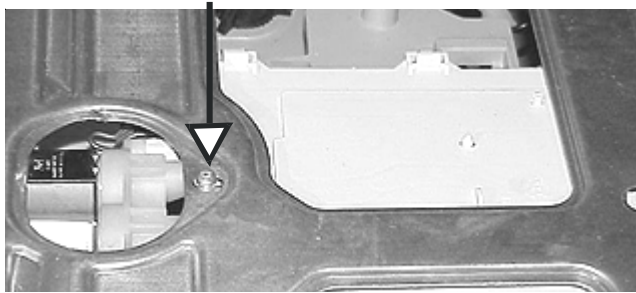

9. Push to release catches on upper front corners and the center of dispenser assembly and push dispenser rearward.

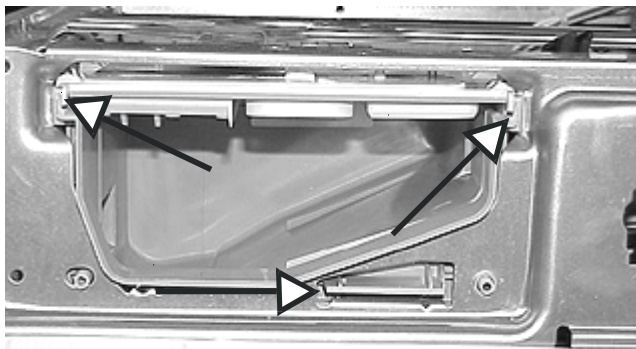

10. Remove the four screws (two on each side) securing the control mounting bracket to the washer cabinet.

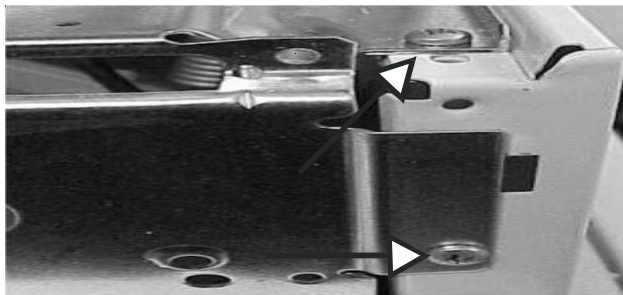

11. Lift upward on the control mounting bracket, reach in and pull out the dispenser.



#### Removing the pressure switch:

1. Disconnect the laundry center from the electrical supply.
2. Remove the top panel.
3. Disconnect the wiring and the hose from the pressure switch.
4. Remove the one screw holding pressure switch to the top brace.

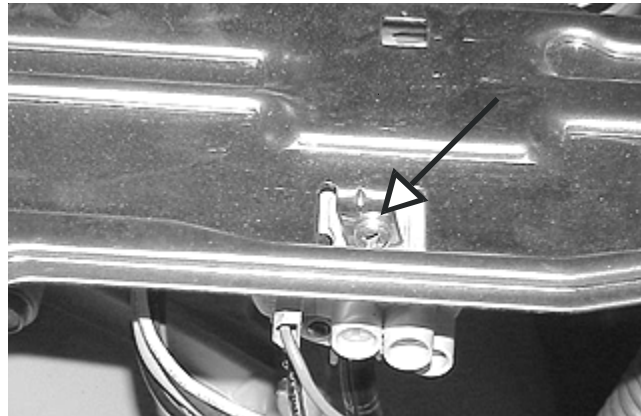

#### Removing the suspension springs:

1. Disconnect the laundry center from the electrical supply.
2. Remove the top panel.
3. Remove the two screws holding the suspension spring retainers to the control mounting panel.

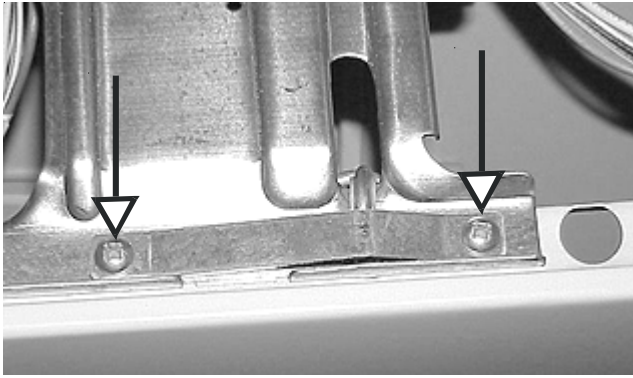

4. Remove the spring retainer and reinstall the two screws.
5. Detach the spring from the control mounting plate by grasping the tub assembly on the lower tub reinforcement area and lifting (4:00 and 7:00 position approx.) while guiding the top end of the spring with the other hand.
6. Rotate the spring to release it from the tub.

**Removing the water inlet valve:**

1. Disconnect the laundry center from the electrical supply and turn off the water supply.
2. Remove the dryer access panel and the washer top panel.
3. Disconnect the two inlet hoses.
4. Unplug the wiring harness and disconnect the outlet hose.

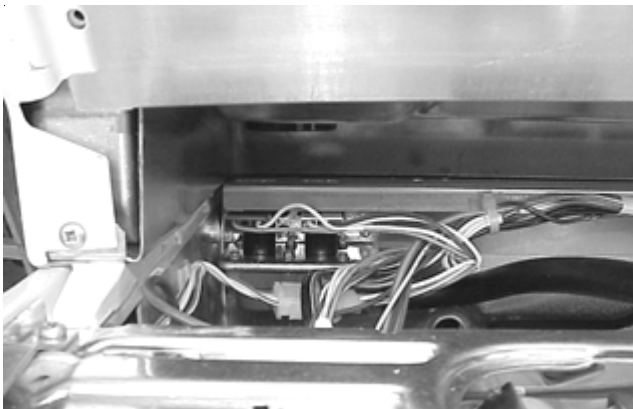

5. Remove the two screws securing the valve to the rear reinforcement bracket.

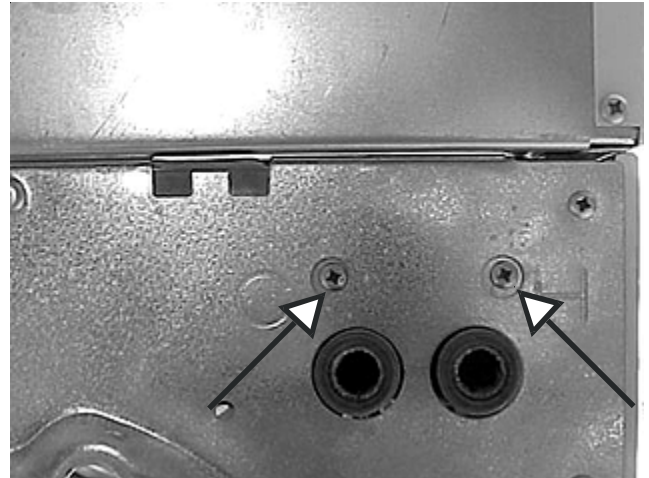

**Removing the drain pump assembly:**

1. Disconnect the laundry center from the electrical supply.
2. Remove the front access panel from the washer.
3. Release the tab securing motor cover to pump and slide the cover back and off.

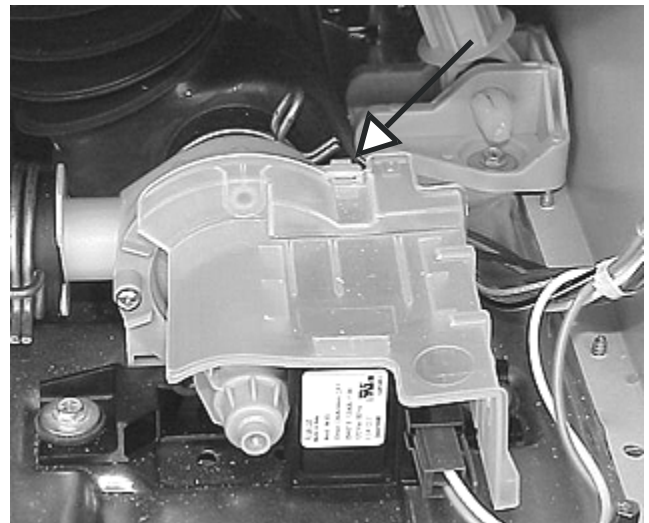

4. Disconnect electrical harness plug from pump motor.
5. Remove drain hose from drain and empty any remaining water in hose. Use a large pot or pan.
6. Disconnect the hoses from the pump.

- Remove two 5/16" hex head screws securing the drain motor and pump assembly to the cabinet base and lift the assembly out.

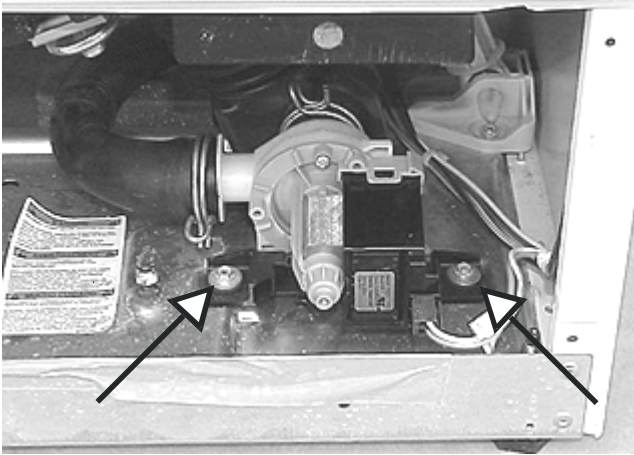

**Disassembling the drain pump:**

- Disconnect the laundry center from the electrical supply.
- Remove the drain pump from the washer.
- The check valve is located in the output connection of the pump. To remove the check valve lift it off its tab.

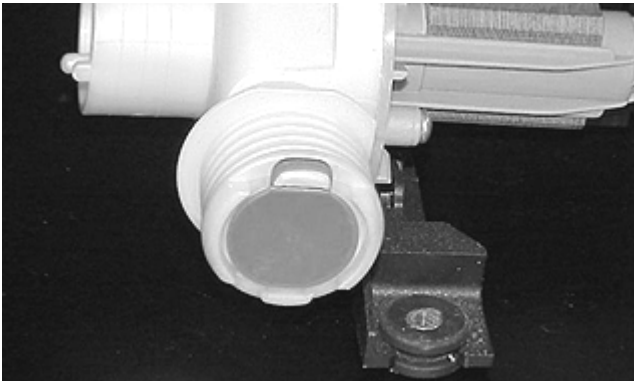

- To remove the rear pump housing, remove three screws locking the housings together and pull the housings apart. (Do not twist.)

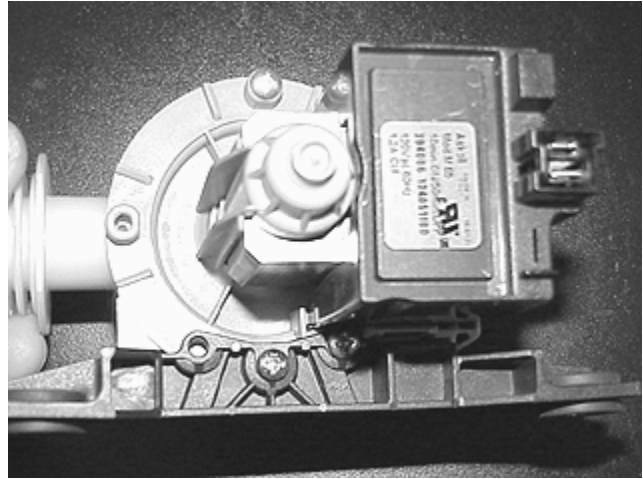

**To remove the air bell:**

- Disconnect the laundry center from the electrical supply.
- Remove the front access panel from the washer.
- Remove drain hose from drain and empty any remaining water in hose. Use a large pot or pan.
- Remove clamp securing air bell to sump hose and remove connecting tube from air bell.

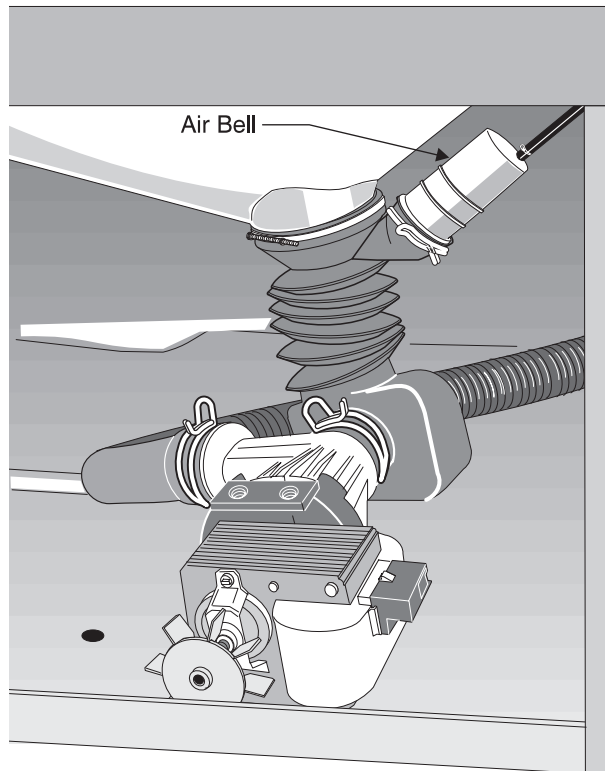



NOTE: Seal air connecting tube to air bell and air bell to sump hose using waterproof glue such as p/n 5364709100. DO NOT plug air connecting tube opening.

#### Removing the back service panel:

1. Disconnect the laundry center from the electrical supply and turn off the water supply.
2. Disconnect the water inlet hoses and remove the top panel.
3. Remove the sixteen screws holding the back panel to the top brace, sides and bottom.



3. Unplug the two electrical plugs, remove the two screws holding the mounting bracket to the base and pull back and up to release the tab.

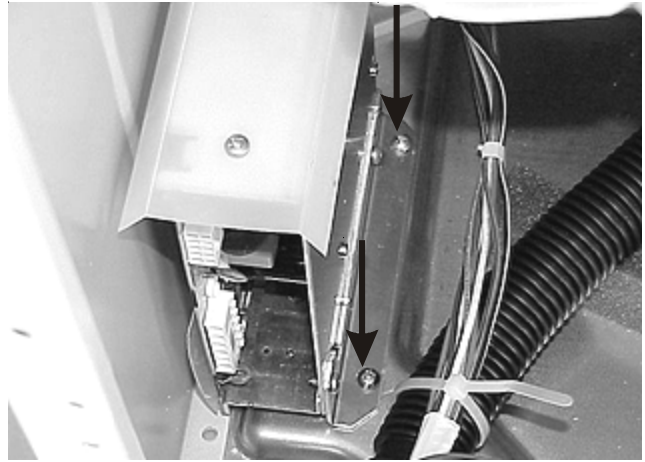

4. To remove the mounting bracket remove the three screws, two on the side and one in the front, holding the bracket to the assembly.

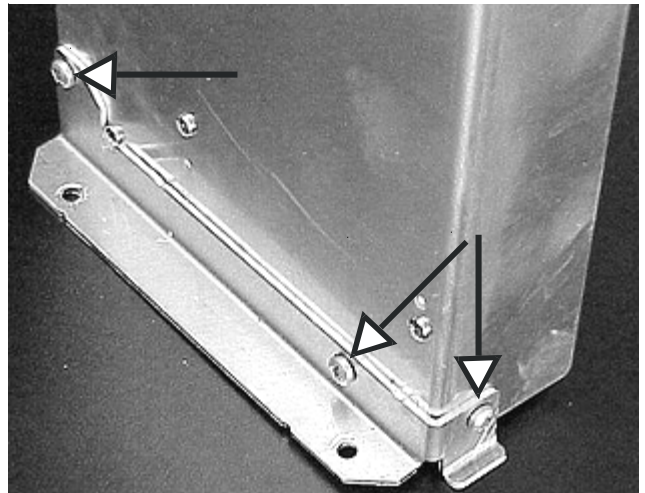

5. To remove the top plastic shield, remove the two screws holding the shield to the speed control board assembly.

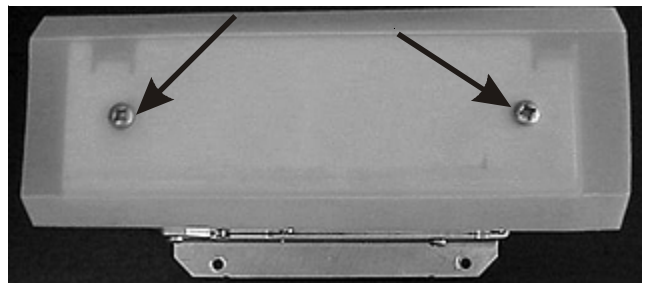

#### Removing the speed control board assembly:

1. Disconnect the laundry center from the electrical supply and turn off the water supply.
2. Remove the rear service panel.

### Drive belt:

The drive belt (6 rib flat Poly-V) is used to transmit power from the motor pulley to the tub. The belt is constructed of a material that stretches, which makes belt tension adjustments unnecessary.

### To remove or replace the drive belt:

1. Disconnect the laundry center from the electrical supply.
2. Remove rear service panel.
3. Remove belt by turning tub drive pulley and rolling belt off pulley. The belt is elastic and is designed to "give" enough to remove and install in this manner.

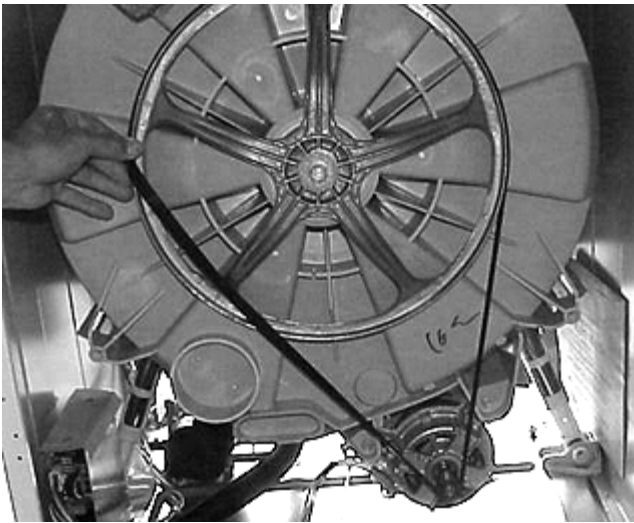

4. Reverse procedure to reinstall, making sure that belt tracks in the center of the tub pulley. Adjust tracking, if required, by moving belt on motor pulley.

### Removing the drive motor:

1. Disconnect the laundry center from the electrical supply.
2. Remove rear service panel.
3. Remove belt by turning tub drive pulley and rolling belt off pulley. The belt is elastic and is designed to "give" enough to remove and install in this manner.
4. Disconnect the wiring harness connector block.

5. Remove motor mounting bolts.

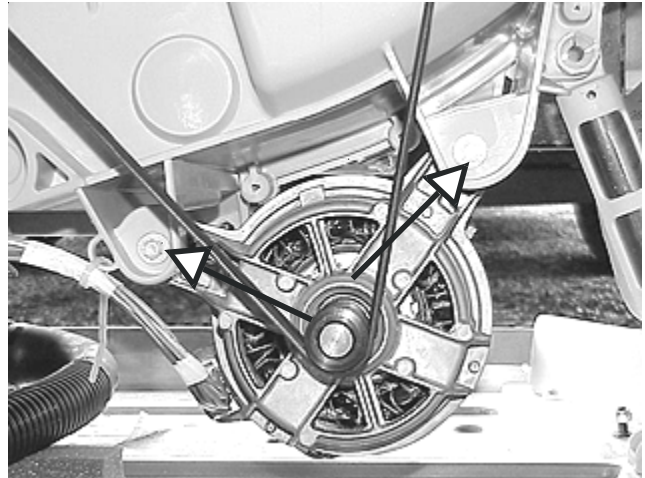

6. Slide motor to front while supporting to remove.

7. Reverse procedure to reinstall, making sure that belt tracks in the center of the large pulley. Adjust by moving the belt on the motor pulley if required.

### Removing the large pulley:

1. Disconnect the laundry center from the electrical supply and turn off the water supply.
2. Remove the rear service panel and remove belt.
3. Using a 9/16" wrench, remove the bolt in the center of the pulley by holding the pulley and turning the bolt counter clockwise.

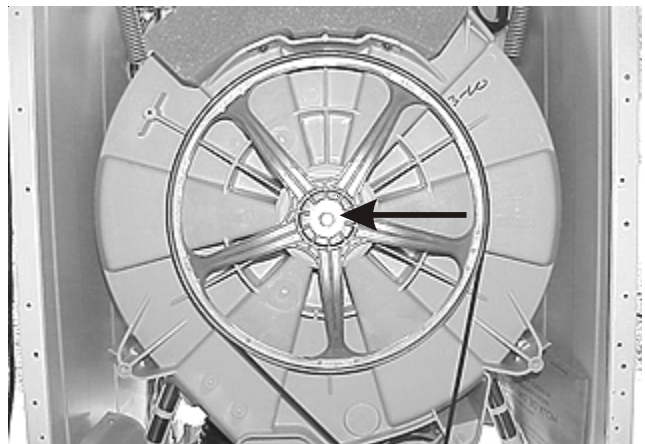

### Removing the rear counter weight:

1. Disconnect the laundry center from the electrical supply and turn off the water supply.
2. Remove the top panel and the rear service panel.



- Using a 7/16" wrench remove the two bolts holding the weight to the back half of the outer tub.

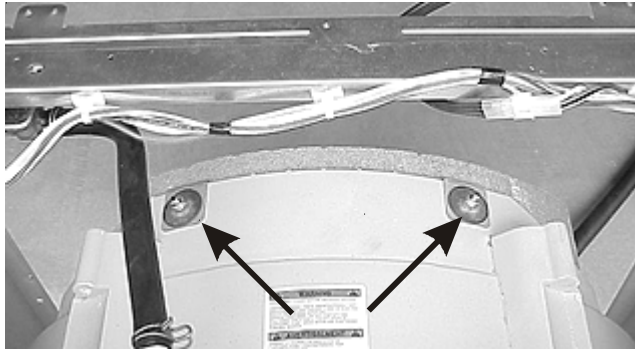

### Removing the air shock absorber:

- Disconnect the laundry center from electrical supply and turn off the water supply.
- Remove the front and the rear service panel.
- Remove air shock securement pins by depressing locking tab while pulling pin to remove. This procedure is much easier if a deep 1/2", 6 point socket (or 13 millimeter, 6 point) is used to compress the locking tab of the plastic pin. Push the socket onto the tapered end of the pin as far as it will go to compress the locking tab.

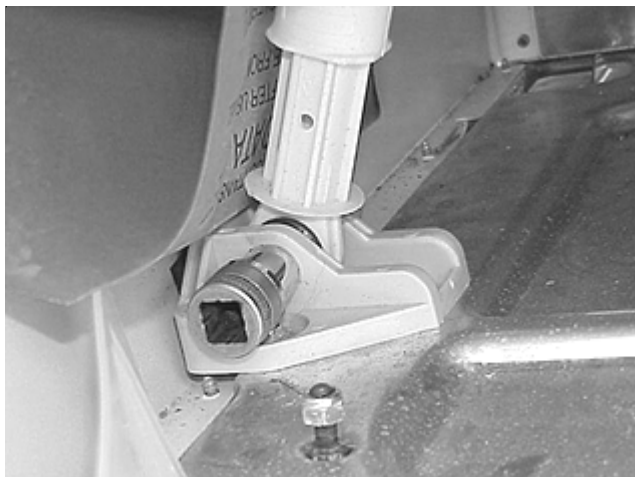

- Use pliers to grasp head of pin and pull to remove. As the pin is removed, the socket will drop free.
- When replacing the air shock, make sure to position it with the bell end facing downward.
- Lubricate the securement pins with Sil-Glide® before installing.

### Removing the outer tub:

- Disconnect the electrical supply and gas (if gas dryer) from the laundry center.
- Shut off the water supply, disconnect the water supply hoses from water valve and move the laundry center away from the walls.
- Remove dryer section from top of section washer.
- Remove the washer section top panel.
- Remove rear access panel from washer section.
- Disconnect the motor wiring harness connector block. Remove wire tie to free harness from tub.
- Remove pressure fill tube from water level control.
- Remove the washer section front access panel.
- Loosen clamp securing sump hose from tub and remove bellows style hose from tub.
- Remove wire spring clamp from air bell.
- Remove the two air shock upper securement pins.
- Pull upper end of air shocks free from tub and position shocks upright away from tub for clearance.
- Protect floor and carefully lay washer on its back.
- Remove the vent hose
- Pull outer lip of boot from flange on front panel and disconnect the boot from the fill tube.
- Remove one screw of the suspension spring retaining strap and loosen the other one. Pivot strap out of the way to permit access to spring. Remove suspension springs from washer cabinet and then from outer tub.
- Carefully lift cabinet to clear tub assembly and set aside.

### Removing the spin basket and rear tub half:

- Disconnect the laundry center from the electrical supply.
- Remove outer tub assembly.

- Remove the screws (23) securing the outer tub halves together. Rotate tub assembly so that front opening is face down.
- Remove belt by turning tub drive pulley and rolling belt off pulley. The belt is elastic and is designed to "give" enough to remove and install in this manner.
- Remove large pulley from shaft.
- Remove the drive motor.
- Separate outer tub halves. **CAUTION: Use caution in handling the spin basket. The outer surface is very sharp!** The replacement rear outer tub half comes with new bearings, water seal, and tub seal between halves already installed.
- Reverse procedure to reassemble using illustration below to show outer tub screw tightening sequence.

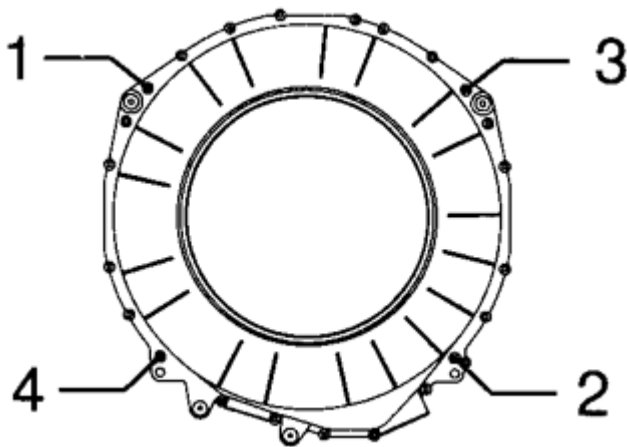

#### Removing the front counterweight:

- Remove the outer tub.
- Using a 7/16" wrench, remove the bolts holding the counterweight to the front half of the outer tub.

#### Removing the spin basket vanes:

There are three plastic vanes mounted to the spin basket to aid in the washing action during the wash cycle. The vanes are secured by a screw and a tab bent into place on the outside of the spin basket.

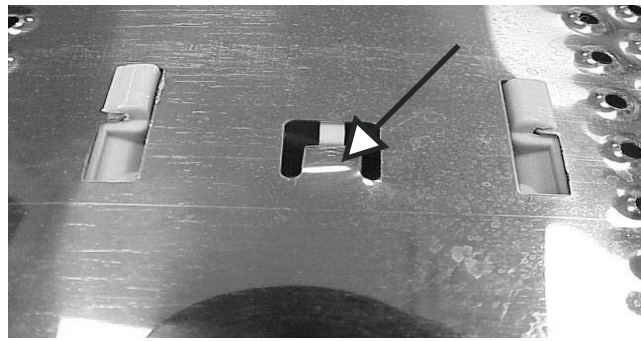

- Remove the screw securing the vane to the spin basket.
- Insert a 1/8" shafted punch in to the fifth hole at the top of the vane.

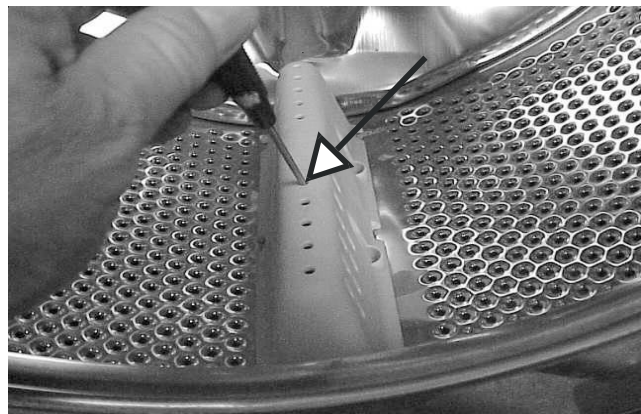

- Push the tab down to release the vane from the tub.
- Slide vane forward toward door opening until it stops.
- Pull vane upwards to disengage tabs on vane from slots in spin basket.
- Reverse procedure to replace. If screw hole on spin basket is stripped, drive screw into other hole on vane to secure.

#### Removing the spacers between the dryer section and the washer section:

- Disconnect the electrical supply and gas (if gas dryer) from the laundry center.
- Remove the dryer section.

3. Remove the screw holding the spacer to the washer section side panel.

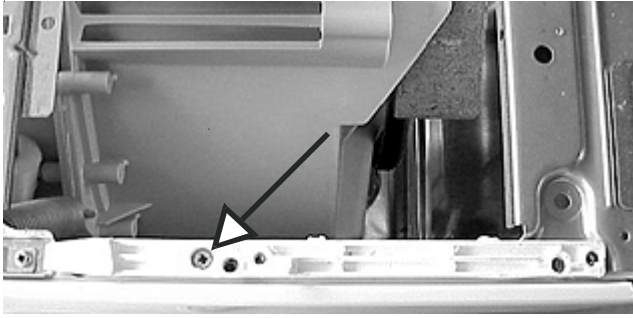

**Removing the mounting brackets:**

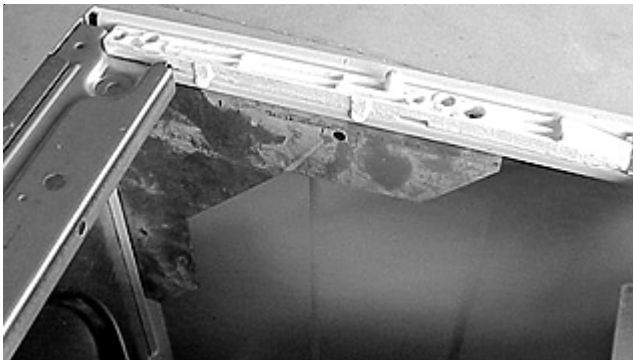

1. Disconnect the electrical supply and gas (If gas dryer) from the laundry center.
2. Remove the dryer section.

3. Remove the spacer and disconnect the wiring harness from the bracket.

4. Remove the two screws from the top holding the bracket to the side panel.

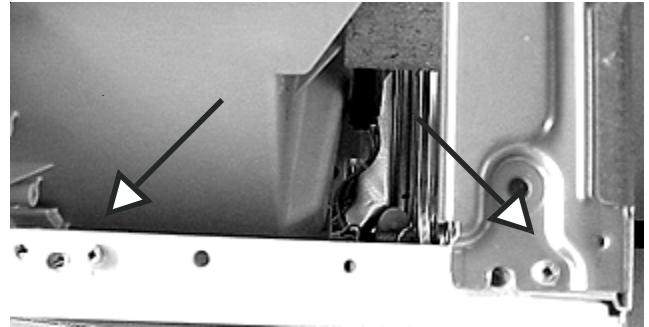

5. Remove the three top side screws from the washer section back panel and drop the bracket down.

