



ELECTROLUX HOME PRODUCTS NORTH AMERICA

SERVICE MANUAL

TOP LOAD WASHERS

***2.7 & 3.0 Cu. Ft.
Tubs***

Frigidaire

TAPPAN

W White-Westinghouse

Gibson

Kelvinator 

5995377099

November 2002

SAFE SERVICING PRACTICES - ALL APPLIANCES

To avoid personal injury and/or property damage, it is important that **Safe Servicing Practices** be observed. The following are some limited examples of safe practices:

1. **DO NOT** attempt a product repair if you have any doubts as to your ability to complete it in a safe and satisfactory manner.
2. Before servicing or moving an appliance:
 - Remove the power cord from the electrical outlet, trip the circuit breaker to the OFF position, or remove the fuse.
 - Turn off the gas supply.
 - Turn off the water supply.
3. Never interfere with the proper operation of any safety device.
4. **USE ONLY REPLACEMENT PARTS CATALOGED FOR THIS APPLIANCE. SUBSTITUTIONS MAY DEFEAT COMPLIANCE WITH SAFETY STANDARDS SET FOR HOME APPLIANCES.**
5. **GROUNDING:** The standard color coding for safety ground wires is **GREEN**, or **GREEN** with **YELLOW STRIPES**. Ground leads are not to be used as current carrying conductors. It is **EXTREMELY** important that the service technician reestablish all safety grounds prior to completion of service. Failure to do so will create a hazard.
6. Prior to returning the product to service, ensure that:
 - All electrical connections are correct and secure
 - All electrical leads are properly dressed and secured away from sharp edges, high-temperature components, and moving parts
 - All non-insulated electrical terminals, connectors, heaters, etc. are adequately spaced away from all metal parts and panels
 - All safety grounds (both internal and external) are correctly and securely connected
 - All panels are properly and securely reassembled

ATTENTION!!!

This service manual is intended for use by persons having electrical and mechanical training and a level of knowledge of these subjects generally considered acceptable in the appliance repair trade. Electrolux Home Products cannot be responsible, nor assume any liability, for injury or damage of any kind arising from the use of this manual.

SAFE SERVICING PRACTICES	2
QUICK REFERENCE SHEET	7 - 9
Serial nameplate location	7
Serial number breakdown	7
Tech sheet location	7
Specification	8
Connecting drive motor for bench check	9
SAMPLE WIRING DIAGRAM	10
SAMPLE TIMER CHART	11
SECTION A - OPERATING INSTRUCTIONS	12 - 14
Before operating your washer	12
Operating steps	12
Cycle selection	12
Whites cycle	12
Extra rinse cycle	12
Colors cycle	12
Knits & delicates cycle	13
Soak & prewash cycle	13
Soak	13
Prewash	13
Power scrub option	13
Automatic extra rinse option	13 - 14
Controls	13
Agitate/spin speeds	14
Wash/rinse temperature	14
Precision temp control	14
Load size	14
Energy saving tips	14
SECTION B - OWNERS GUIDE	15 - 29
Safety information	15 - 16
For your safety	15
Product registration	15
Important safety instructions	15
Prevent fire	15
Protect children	15
Prevent injury	16
Washing procedures	17 - 19
Sorting laundry	17
Prepare items for washing	17
Pretreat stains and heavy soil	17
Adding detergent	18
Adding liquid bleach	18
Adding laundry	18
Adding liquid fabric softener	18
For models with a removable dispenser	19
For models without a fabric softener dispenser	19
Set cycle selector knob and washer controls	19
Start the washer	19
Remove items when the cycle is completed	19
Stain removal	19 - 21
Safe stain removal procedures	19
For successful stain removal	20
Stain removal chart	20 - 21
Common washing problems	22 - 23
Care and cleaning	24

Inside	24
Outside	24
Winterizing instructions	24
Avoid service checklist	25 - 26
Sample warranty USA	27
Service information (Canada)	28
Sample warranty Canada	29
SECTION C - INSTALLATION INSTRUCTIONS	30 - 33
Full size automatic washer	30
Pre-installation requirements	30
Tools required for installation	30
Electrical requirement	30
Circuit	30
Power supply	30
Outlet receptacle	30
Grounding requirements	30
Water supply requirements	30
Drain requirements	31
Rough-in dimensions	31
Location of your washer	31
Do not install your washer	31
Unpacking	31
Installation	32
Replacement parts	33
United States	33
Canada	33
SECTION D - PARTS LOCATION AND THEIR FUNCTION	34 - 42
Timer	34
Speed combination switch	34
Sample timer cycle chart	35
Pressure switch assembly	36
Wash cycle options switch	36
Wash/rinse temperature switch	36
Auto temp system	37
The end of cycle signal switch	37
The end of cycle signal	37
Lid lock assembly	38
Softener dispenser	38
Agitator	38
Bleach dispenser	38
Water inlet valve	39
Valve operation	39
Drain pump	40
The motor	40
Transmission	40
Spin basket or inner tub	41
Splash tub cover	42
Outer tub	42
Leg and dome assembly	42
Snubber	42
Base	42
SECTION E - ELECTRICAL OPERATION	43 - 46
Option switch circuits	43
Line switch circuit	44
Fill circuit	44 - 45
During the wash cycle	44

Spray rinse during the first pump cycle	45
During the rinse cycle	46
Drive motor circuit	47 - 50
Motor in agitation cycle	47 - 48
Motor in spin cycle	49 - 50
SECTION F - TROUBLESHOOTING FLOW CHARTS	51 - 61
Washer completely inoperative	52
Timer does not advance	52
Washer does not drain	53
Drive motor operates in spin but not in agitation	53
Drive motor does not turn	54
Drive motor operates in agitation but not in spin	55
Slow water fill	55
Drive motor cycles off and on rapidly when the speed switch set to normal	56
Drive motor cycles off and on rapidly when the speed switch set to gentle	56
Drive motor cycles off and on rapidly when the speed switch set to ex. gentle	57
Auto temp control does not control the wash water temperature within specifications	57
Water fill does not turn off	58
Incorrect water level	58
Washer will not fill in any setting of the temperature selector sw	59
Washer will not fill in wash cycle, but will fill in rinse with the temp switch set to cold/cold	60
Washer will only fill with cold water in the wash cycle, with the temp switch set to warm/cold	60
Water temperature is too hot or too cold in the wash cycle with the temp sw. set to warm/warm	61
Washer will only fill with hot water in the wash cycle, with the temp switch set to warm/cold but does fill with cold water in the rinse cycle	61
SECTION G - TEARDOWN	62 - 79
Removing the knobs	62
Timer knob (some models)	62
Timer knob (some models)	62
Timer skirt (some models)	62
Timer skirt (some models)	63
All other knobs	63
Raising the top	63
Removing the rear panel from console	63
Removing the timer (some models)	64
Removing the timer (some models)	64
Removing the speed switch, option switch or temp switch	64
Removing the end of cycle signal	65
Removing the end of cycle signal switch	65
Removing the pressure switch assembly	66
Removing the electronic moisture sensor control	66
Removing the front closure	66
Removing the console	67
Removing the end caps	67
Removing the console's front panel	68
Removing the lid lock assembly	68
Removing the lid hinges	68
Removing the lid spring	69
Removing the lid	69
Removing the water inlet nozzle assembly	69
Removing the bleach dispenser	69
Replacing the top	70

Removing the top hinges _____	70
Removing the water inlet valve _____	70
Alternate water valve attachment _____	70
Removing the ATC sensor _____	71
Removing the front panel _____	71
Removing the drain pump _____	71
Disassembling the drain pump _____	72
Removing the softener dispenser _____	72
Removing the mechanism cap _____	72
Reinstalling the mechanism cap _____	73
Removing the agitator _____	73
Removing the drive hub _____	73
Removing the splash tub cover _____	74
Removing the spin basket _____	74
Removing the trunnion _____	74
Removing the top half of the tub seal _____	75
Removing the bottom half of the tub seal _____	75
Removing the outer tub _____	75
Removing the tub bearing _____	75
Removing the drive belt _____	76
Removing the transmission pulley _____	76
Removing the transmission _____	76
Replacing the vertical springs _____	76
Removing the idler pulley assembly _____	77
Removing the snubber _____	77
Removing the drive motor shield _____	77
Removing the start capacitor _____	78
Removing the drive motor _____	78
Removing the leg and dome assembly _____	79
Removing the base _____	79

QUICK REFERENCE SHEET

1. Serial nameplate location:

On the under side of the lid, in the top right-hand corner.



2. Serial number breakdown.

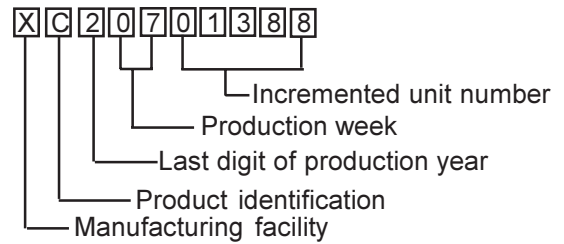

3. Tech sheet location

Inside the console

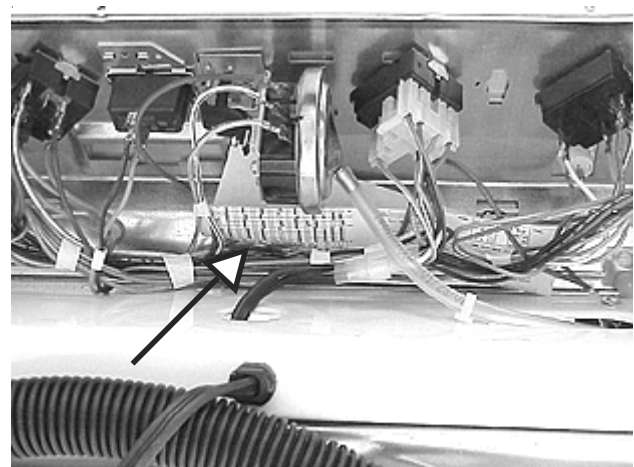

Specifications

Washer	2.7 Cu. Ft. tub	3.0 Cu. Ft. tub
Transmission		
Agitate Speed Oscillations Per Minute (High)	71 - 77	71 - 77
Agitate Speed Oscillations Per Minute (Low)	47 - 51	47 - 51
Agitate Speed Oscillations Per Minute (Gentle)	33 - 37	33 - 37
Spin Speed R.P.M. (High Speed)	600 - 640	600 - 640
Spin Speed R.P.M. (Low Speed)	390 - 420	390 - 420
Oil Capacity (Ounces)	32	32
Motor		
Motor HP @ 120V, 60Hz. (Min OP - 100V Internal Thermal Overload Protection, Capacitor Start (189 - 210 Mfd., 135 Volt)	1/2 & 3/4	1/2 & 3/4
One Speed (RPM)	1725	1725
Two Speed (RPM)	1150/1725	1150/1725
Three Speed (RPM)	840/1150/1725	840/1150/1725
Agitate		
Agitate Wattage - Full Load (High Speed) Max.	750	950
Agitate Wattage - Full Load (Low Speed) Max.	450	475
Agitate Wattage - Full Load (Ex. Low Speed) Max.		475
Spin		
Full Spin Wattage - No Load (High Speed)	300 - 660	300 - 660
Full Spin Wattage - No Load (Low Speed)	250 - 575	250 - 575
Spin Wattage - No Load (High Speed) Max. After 10 Sec.	800	800
Spin Wattage - No Load (High Speed) Max. After 10 Sec.	700	700
Full Spin Wattage - Full Load (High Speed)	300 - 660	300 - 660
Full Spin Wattage - Full Load (Low Speed)	250 - 575	250 - 575
Spin Wattage - Full Load (High Speed) Max. After 10 Sec.	900	900
Spin Wattage - Full Load (High Speed) Max. After 10 Sec.	700	700
Tub Capacity / Water Usage		
Capacity (Cu. Ft.)	2.7	3.0
Water Level (Inches) Measured from tub bottom		
Large	10.8 - 13.0	13.5 - 15.2
Small	4.3 - 6.6	5.5 - 7.8
Water Supply		
Pressure (P.S.I.) Minimum/Maximum	30/120	30/120
Water Flow Rate (G.P.M.)	3 - 14.6	3 - 14.6
Drain Pumpout		
G.P.M. @ 36" (Min.)	12	12
G.P.M. @ 96" (Min.)	7	7
Agitator Clearance		
Agitator Bottom to Tub	.050 - .300	.050 - .300
Component resistance - Ohms +/- 10% @ 77°F		
Motor		
4 Pole Main Winding (High Speed)	2.4	2.4
6 Pole Main Winding (Low Speed) If 2 Speed Motor	1.5	1.5
Fill Valve		
Hot Water Solenoid	880	880
Cold Water Solenoid	880	880
Timer Motor	2322	2322
Pump Motor - Ohms +/- 7% @ 68°F	12	12
ATC - Ohms +/- 2% @ 77°F	50000	50000

Connecting drive motor for bench check

Two Speed

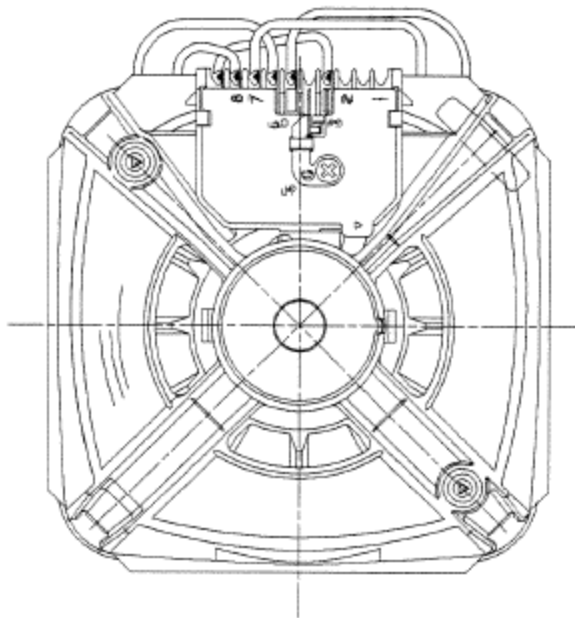

ROTATION GIVEN VIEWING LEAD END

ROTATION	SPEED	L1	L2	7
CCW	HI	3	6,1	5
CCW	LO	3	2,1	5
CW	HI	3	6,5	1
CW	LO	3	2,5	1

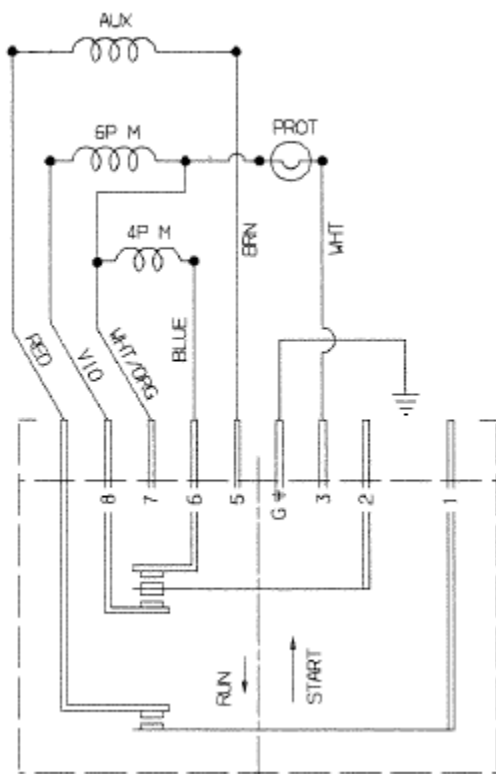

Three Speed

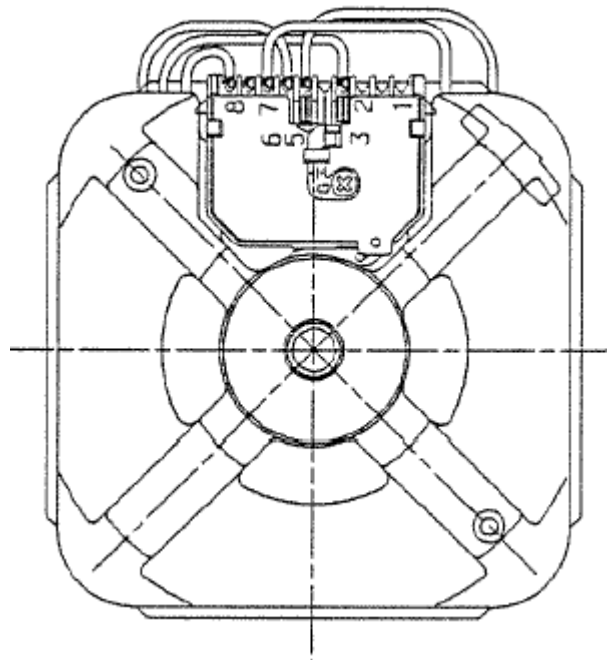

ROTATION GIVEN VIEWING LEAD END

ROTATION	SPEED	L1	L2	7	8
CCW	HI	3	6,1	5	--
CCW	LO	3	2,1	5	W/OR
CCW	EX. LO	3	2,1	5	W/V
CW	HI	3	6,5	1	--
CW	LO	3	2,5	1	W/OR
CW	EX. LO	3	2,5	1	W/V

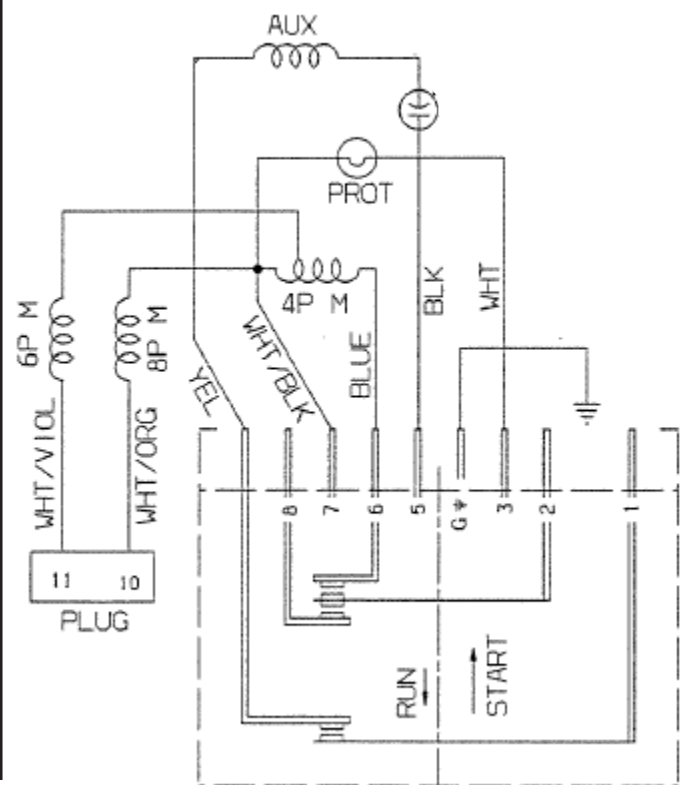

SAMPLE WIRING DIAGRAM

Caution: Disconnect Electrical Current Before Servicing

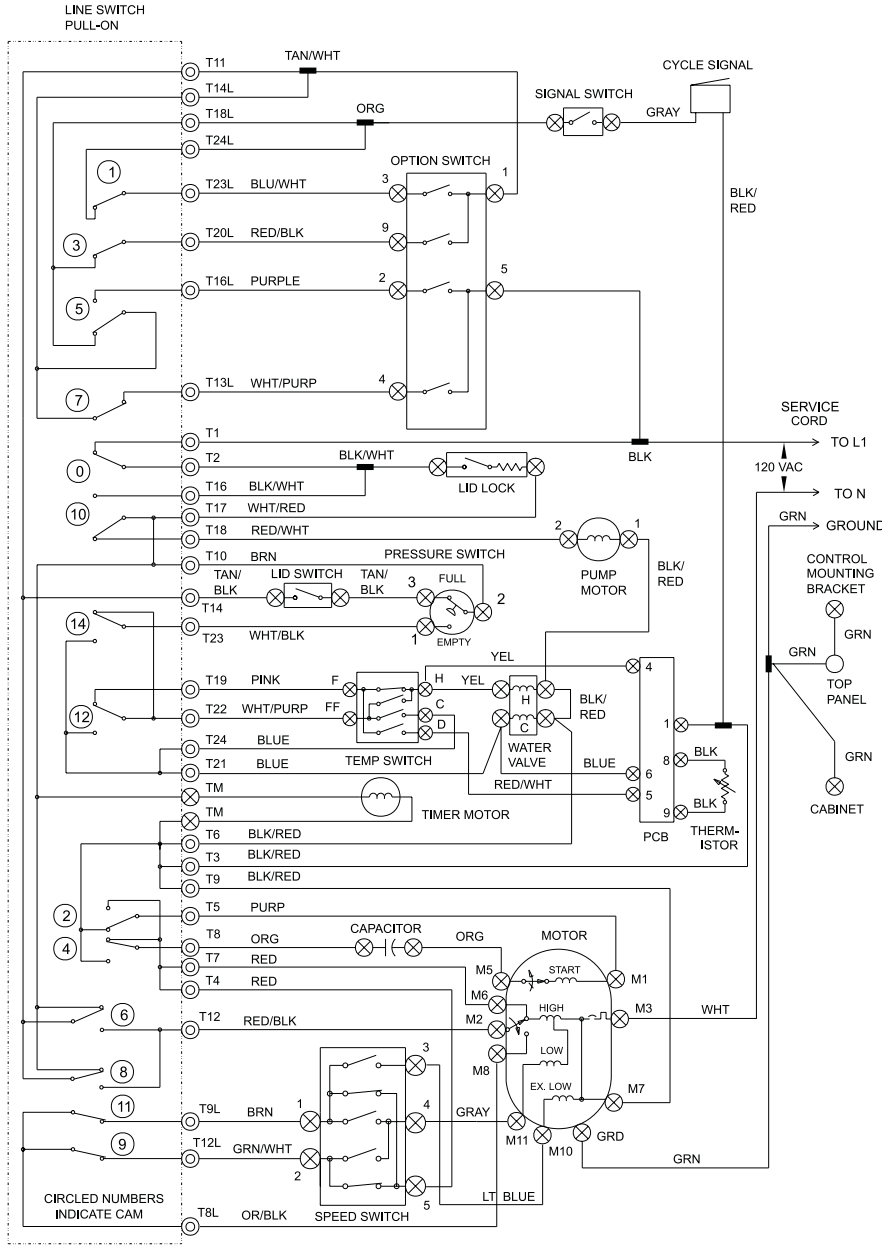

WIRING CODES	
⊙	PLUG IN TIMER TERMINAL
⊗	QUICK DISCONNECT TERMINAL
○	SCREW TERMINAL
+	CONNECTION
+	NO CONNECTION
⊗	MOTOR SWITCH
⊞	SPLICE
⊞	MOTOR PROTECTOR
⊞	CHASSIS (CABINET) GROUND

SPEED SWITCH CIRCUIT					
AGIT/SPIN	1-5	1-4	2-4	2-5	1-3
N/F	X			X	
G/F		X			X
G/S		X	X		
EG/S			X		X

N=NORMAL F=FAST EG=EXTRA GENTLE
G=GENTLE S=SLOW

TEMPERATURE SWITCH CIRCUIT				
WASH/RINSE	F-H	FF-H	FF-C	F-D
H/C	X			
W/C	X		X	
C/C			X	
W/W		X	X	
R/C/C			X	X
R/W/C	X			X
R/W/W		X		X

H=HOT R=REGULATED
C=COLD W=WARM

WASHER TIMER

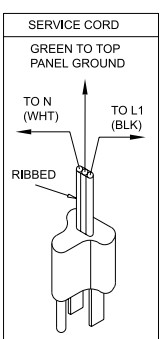

DETAIL FOR SPRAY SUBINTERVAL AND SPIN MOTOR CONTROL CIRCUITS.

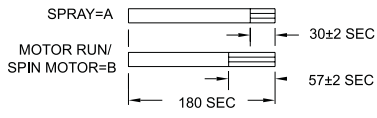

OPTION SWITCH					
POS	OPTION	1-9	1-3	5-4	5-2
1	POWER SCRUB/ EXTRA RINSE			X	X
2	EXTRA RINSE	X		X	
3	POWER SCRUB		X		X
4	OFF	X	X		

X=SWITCH CLOSED

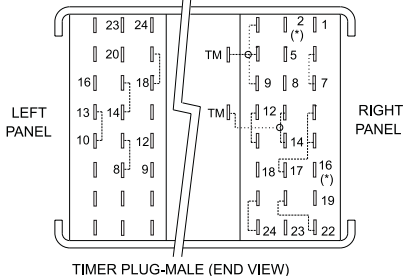

TIMER PLUG-MALE (END VIEW)

SAMPLE TIMER CYCLE CHART

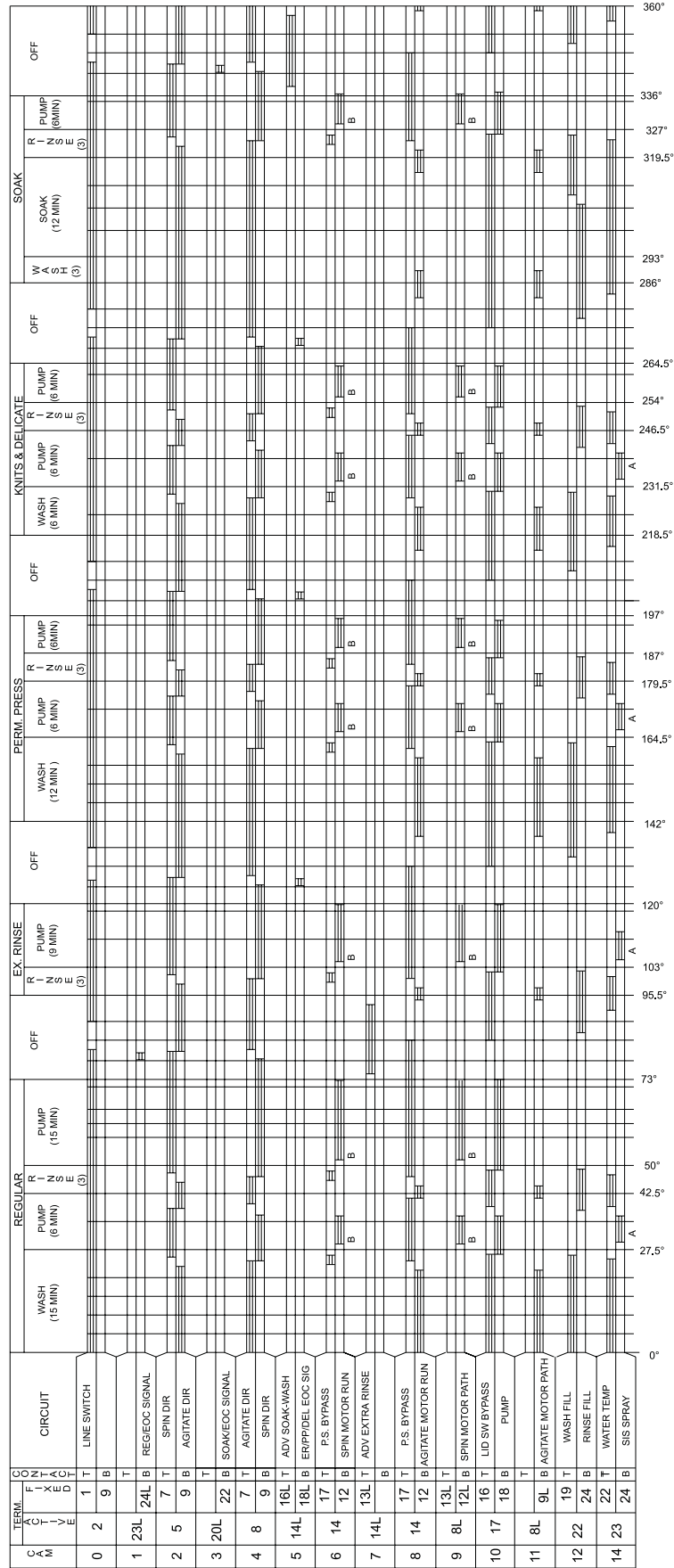

SECTION A - OPERATING INSTRUCTIONS

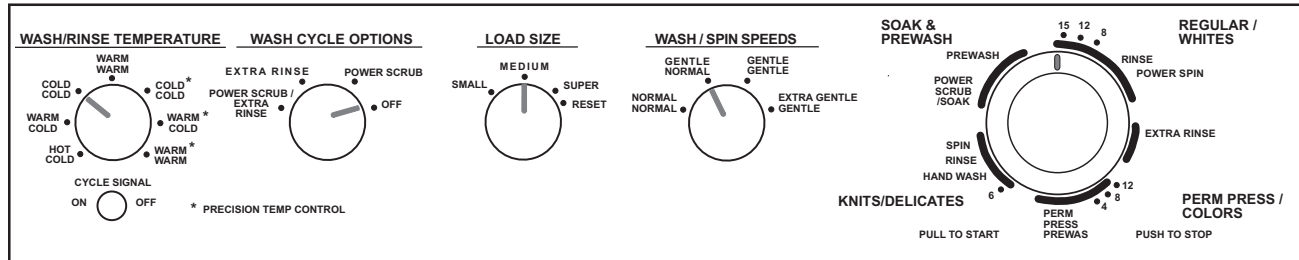

Versión en español

Si desea obtener una copia en español de estas Instrucciones de Funcionamiento, sírvase escribir a la dirección que se incluye a continuación. Solicite la P/N 134108600.

Spanish Owner's Guides
Electrolux Home Products
P. O. Box 212378
Augusta, GA 30917

Before Operating Your Washer

Read your washer Owner's Guide. It has important safety and warranty information. It also has many suggestions for best washing results.

⚠ WARNING To reduce the risk of fire, electric shock, or injury to persons, read the IMPORTANT SAFETY INSTRUCTIONS in your washer Owner's Guide before operating this appliance.

Operating Steps

Read Washing Procedures in your Owner's Guide. It explains these operating steps in detail.

1. Sort laundry into loads that can be washed together.
2. Prepare items for washing.
3. Pretreat stains and heavy soil.
4. Add the measured amount of detergent to wash tub.
5. If desired, add liquid bleach to Bleach Dispenser.
6. Add laundry load to wash tub.
7. If desired, add liquid fabric softener to Fabric Softener Dispenser.
8. Set cycle selector and washer controls according to type, size, and soil level of each load.

9. Close lid and pull cycle selector knob to start washer.

10. Remove items at end of cycle. A signal will sound at the end of the cycle when the **End of Cycle Signal** is turned on. Wait about 1 minute for safety lid lock to release.

Cycle Selection

Always follow instructions on fabric care labels.

The Whites, Colors, and Knits & Delicates cycles provide a spray rinse during the first spin, followed by a deep rinse and final spin.

Whites Cycle

Provides up to 15 minutes of wash agitation for most fabrics. **Power Spin** provides 12 minutes of spin at a selected speed for maximum removal of water. This conserves energy by reducing drying time.

Extra Rinse Cycle

- Use Extra Rinse to remove excess dirt and detergent from heavily soiled loads. Extra Rinse provides 3 minutes of rinse agitation, then a 9 minute spin.
- Select **Automatic Extra Rinse** under **Wash Cycle Options** to automatically advance to Extra Rinse after the Whites cycle is completed.
- Select **Automatic Power Scrub/Extra Rinse** under **Wash Cycle Options** to automatically advance to Extra Rinse after the Soak & Prewash and Whites cycles are completed.

Colors Cycle

Provides 12 minutes of wash agitation for light weight cottons, 8 minutes of wash agitation for items with a no-iron finish or 4 minutes of wash agitation for knits.

Knits & Delicates Cycle

Provides 6 minutes of wash agitation for delicate items or 3 minutes of wash agitation for hand washables.

Soak & Prewash Cycle

Soak

- Use Soak to treat heavily soiled or stained items. Soak provides 3 minutes of agitation and 12 minutes of soaking time. The load then advances into the Prewash portion of the cycle.
- Use the amount of detergent recommended for a normal wash cycle. If desired, use bleach or a soaking agent for colorfast items.
- The Soak water temperature is the same as the rinse water temperature selected.
- Select the Agitate/Spin Speed appropriate for the items being soaked.
- Select Wash Cycle Option **OFF** if advancing into the Whites cycle is not desired.
- Follow Soak with a complete wash cycle using the normal amount of detergent.

Prewash

- Use Prewash when soaking is not necessary. Prewash helps remove protein-based stains such as milk, grass and blood. It also helps loosen soils before washing. Prewash provides 3 minutes of wash agitation.
- Use the amount of detergent recommended for a normal wash cycle.
- The Prewash water temperature is the same as the wash water temperature selected. To avoid setting protein stains, select cold water.
- Select the Agitate/Spin Speed appropriate for the items being prewashed.
- Select Wash Cycle Option **OFF** if advancing into the Whites cycle is not desired.
- Follow Prewash with a complete wash cycle using the normal amount of detergent.

Power Scrub Option

Select **Power Scrub** to automatically advance a load

from the Soak or Prewash setting into the Whites wash and Extra Rinse cycles.

1. **Add the measured amount of detergent to wash tub, then add wash load.**
2. **Select appropriate Wash/Rinse Temperature, Load Size, and Agitate/Spin Speed.**
3. **Select Power Scrub under Wash Cycle Options.**
 - To use a cycle other than Whites after the Soak or Prewash settings, select **OFF** and manually advance cycle selector to cycle desired.
4. **Fill fabric softener dispenser with the recommended amount of LIQUID detergent.** Add water to bring liquid level to fill line on dispenser cap.
 - When selecting Power Scrub, the fabric softener dispenser must be filled with diluted liquid detergent at the beginning of the Soak or Prewash setting. The detergent for the Whites cycle will then be dispensed after the spin in Prewash.
 - **DONOT** use powdered detergent in the dispenser.
 - Clean the fabric softener dispenser thoroughly after each use. Fabric softener and liquid detergent should not be mixed.
5. **Set the cycle selector at Soak or Prewash and pull knob to start.** The washer will provide Soak or Prewash as selected. It then automatically advances to the full Whites and Extra Rinse cycles.

Automatic Extra Rinse Option

Select **Automatic Extra Rinse** or **Power Scrub/Extra Rinse** to provide an extra rinse at the end of the Whites cycle.

Controls

Always follow instructions on fabric care labels.

AGITATE/SPIN SPEEDS offers three agitation speeds and four combinations of agitation and spin speeds for any cycle. The following chart suggests agitate/spin speeds for basic fabric types.

Fabric Type	Agitate/Spin Speed
Regular	Normal/Normal
Perm Press	Normal/Normal
Knits	Gentle/Normal
Delicates / Washable woolens	Gentle/Gentle
Hand washables	Extra Gentle/Gentle

WASH/RINSE TEMPERATURE sets water temperatures for washing and rinsing. Select wash water temperature according to fiber content, soil level and type of detergent. A cold water rinse saves energy and reduces wrinkling.

Precision Temp Control

The normal temperature of warm and cold wash water can be affected by the hot water heater setting and seasonally low ground water temperatures in some geographic areas. Since detergents work best in wash water at a minimum of 65° F, select a **Precision Temp** to regulate the temperature of the warm and cold wash water in any cycle.

Wash water in the **Precision Temp Warm/Cold** and **Precision Temp Warm/Warm** settings is regulated to approximately 90° F. and the wash water in the **Precision Temp Cold/Cold** setting is regulated to approximately 70° F. Rinse water temperatures are not regulated.

- When small wash loads cannot be avoided, use lower water levels.
- Select the appropriate cycle and time for each load. Shorten wash times for lightly soiled loads.
- To reduce drying time, select a fast spin speed to remove more water from heavy items such as towels and jeans.
- Use warm water to wash most loads. Limit hot water washes to heavily soiled and white loads. Use cold water for lightly soiled items and rinsing.
- Operate the washer in early morning and late evening when utility demands are low.
- Follow proper laundry procedures to avoid rewashing.

The following chart suggests wash/rinse temperatures for some typical wash loads.

<u>Fabric Type</u>	<u>Wash/Rinse Temperature</u>
Heavily soiled white/colorfast cotton, perm press	Hot/Cold
Lightly soiled white/colorfast cotton, perm press	Warm/Cold *
Noncolorfast fabrics, knits, delicates, hand washables	Cold/Cold *
Washable woolens	Warm/Warm *
* unregulated or Precision Temp Control	

LOAD SIZE sets the amount of wash and rinse water for the wash load. Select a water level appropriate for the load size. There should be enough water for items to move freely.

- To increase water level after the wash cycle begins, turn the Load Size control to Reset and hold. When water begins to enter the tub, turn the control to the desired setting.

Energy Saving Tips

- Wash full loads. Oversize loads use extra energy. Undersize loads waste energy.

SECTION B - OWNERS GUIDE

Product Registration

Thank you for choosing this washer. This owner's guide will explain proper operation and care.

Record Your Model and Serial Numbers

Record below the model and serial numbers found on the washer serial plate located on the underside of the washer lid. Keep these numbers for future reference.

Model Number _____

Serial Number _____

Date of Purchase _____

Register Your Product

The self-addressed **PRODUCT REGISTRATION CARD** should be filled in completely, signed and returned.

This Owner's Guide provides general operating instructions for your washer. It also contains information about features for several other models. Your washer may not have every feature included here.

Use the washer **only** as instructed in this Owner's Guide and the **Operating Instructions** card included with your washer.

FOR YOUR SAFETY

Do not store or use gasoline or other flammable vapors or liquids in the vicinity of this or any other appliance.

Important Safety Instructions

Read all instructions before using this washer.

⚠ WARNING To reduce the risk of fire, electrical shock, or injury to persons when using this washer, comply with the basic warnings listed below.

⚠ Failure to comply with these warnings could result in serious personal injuries.

Prevent Fire

⚠ WARNING Do not wash items that have been previously cleaned in, soaked in, or spotted with gasoline, cleaning solvents, kerosene, cooking oils,

waxes, etc. Do not store these items on or near the washer. These substances give off vapors or chemical reactions that could ignite or explode.

⚠ WARNING Do not put oily or greasy rags or clothing on top of the washer. These substances give off vapors that could ignite the materials.

⚠ WARNING Do not add gasoline, cleaning solvents, or other flammable or explosive substances to the wash water. These substances give off vapors that could ignite or explode.

⚠ WARNING Under certain conditions, hydrogen gas may be produced in a hot water system that has not been used for 2 weeks or more. **HYDROGEN GAS IS EXPLOSIVE.** If the hot water system has not been used for such a period, before using the washer, turn on all hot water faucets and let the water flow from each for several minutes. This will release any accumulated hydrogen gas. Hydrogen gas is flammable; do not smoke or use an open flame during this time.

⚠ Failure to comply with these warnings could result in fire, explosion, serious bodily injury and/or damage to the rubber or plastic parts of the washer.

Protect Children

⚠ WARNING Do not allow children to play on or in the washer. Close supervision of children is necessary when the washer is used near children. As children grow, teach them the proper, safe use of all appliances.

⚠ WARNING Destroy the carton, plastic bag and other packing materials after the washer is unpacked. Children might use them for play. Cartons covered with rugs, bedspreads or plastic sheets can become airtight chambers.

⚠ WARNING Keep laundry products out of children's reach. To prevent personal injury, observe all warnings on product labels.

⚠ WARNING Before the washer is removed from service or discarded, remove the washer lid to prevent accidental entrapment.

⚠ Failure to comply with these warnings could result in serious personal injuries.

⚠ WARNING **Avoid fire hazard or electrical shock. Do not use an adaptor plug or extension cord or**

remove grounding prong from electrical power cord. Failure to follow this warning can cause serious injury, fire or death.

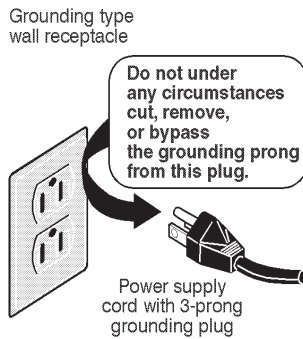

CORRECT
Use this way **ONLY**

⚠ WARNING Do not use or mix liquid chlorine bleach with other household chemicals such as toilet cleaners, rust removers, acid or products containing ammonia. These mixtures can produce dangerous fumes which can cause serious injury or death.



Note: The instructions appearing in this Owner's Guide are not meant to cover every possible condition and situation that may occur. Common sense and caution must be practiced when installing, operating and maintaining any appliance.

Prevent Injury

⚠ WARNING To prevent shock hazard and assure stability during operation, the washer must be installed and electrically grounded by a qualified service person in accordance with local codes. Installation instructions are packed in the washer for installer's reference. Refer to **INSTALLATION INSTRUCTIONS** for detailed grounding procedures. If the washer is moved to a new location, have it checked and reinstalled by a qualified service person.

⚠ WARNING To prevent personal injury or damage to the washer, the electrical power cord of the washer

must be plugged into a properly grounded and polarized 3-prong outlet. **The third grounding prong must never be removed. Never ground the washer to a gas pipe. Do not use an extension cord or an adaptor plug.**

⚠ WARNING Follow package directions when using laundry products. Incorrect usage can produce poisonous gas--resulting in serious injury or death.

- **Do not** combine laundry products for use in 1 load unless specified on the label.
- **Do not** mix chlorine bleach with ammonia or acids such as vinegar.

⚠ WARNING To prevent serious personal injury and damage to the washer:

- **All repairs and servicing must be performed by an authorized servicer** unless specifically recommended in this Owner's Guide. Use only authorized factory parts.
- **Do not** tamper with controls.
- **Do not** install or store the washer where it will be exposed to the weather.

⚠ WARNING ALWAYS disconnect the washer from the electrical supply before attempting any service or cleaning. Failure to do so can result in electrical shock or injury.

⚠ WARNING To prevent injury, do not reach into the washer while parts are moving. Before loading, unloading or adding items, push in the cycle selector knob and allow the tub to coast to a complete stop before reaching inside.

⚠ Failure to comply with these warnings could result in serious personal injuries.

⚠ This washer is equipped with an electrical overload protector. The motor will stop if it becomes overheated. The washer will automatically restart after a cool down period of up to 30 minutes, if the washer has not been manually turned off during this time.

SAVE THESE INSTRUCTIONS

Washing Procedures

- Follow the guidelines below for preparing the wash load.
- Read the **Operating Instructions** card for operating your specific model.
- **Always read and follow fabric care and laundry product labels.**

⚠ WARNING To reduce the risk of fire, electrical shock, or injury to persons, read **Important Safety Instructions**, before operating this washer.

1. Sort laundry into loads that can be washed together.

Sort items by recommended water temperatures, wash time, and agitate/spin speeds.

- Separate white, light, and colorfast items from dark and noncolorfast items.
- Separate items which shed lint from items which attract lint. Permanent press, synthetic, knit and corduroy items will pick up lint from towels, rugs and chenille bedspreads.
- Separate heavily soiled items from lightly soiled items.
- Separate lacy, sheer and loosely knit items from sturdy items.

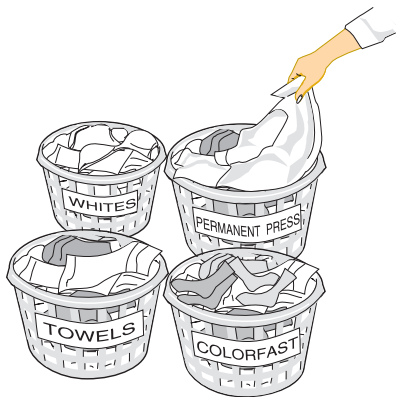

Sort laundry into loads that can be washed together.

2. Prepare items for washing.

- Empty pockets.

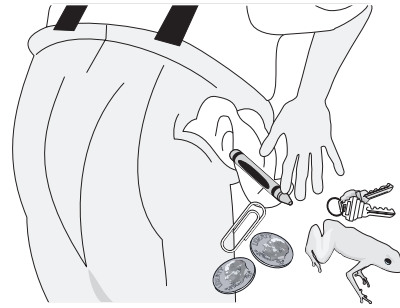

Empty pockets.

- Brush off lint and dirt. Shake out rugs and beach towels.
- Close zippers, fasten hooks, tie strings and sashes, and remove nonwashable trims and ornaments.
- Remove pins, decorative buttons, belt buckles, and other objects which could be damaged. This also helps protect other items in the wash load.
- Mend rips and tears to prevent further damage during washing.
- Place delicate items such as bras, shoulder pads, hosiery, and belts in a mesh bag to prevent tangling during the wash cycle.

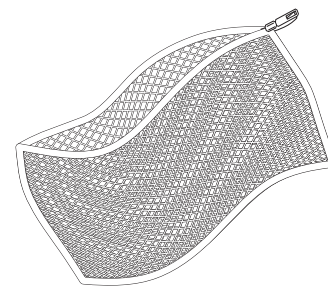

Place delicate items in a mesh bag.

- Turn knit items inside out to prevent pilling.

3. Pretreat stains and heavy soil. See **Stain Removal**.

- ### 4. Add a measured amount of detergent to the wash tub before adding the laundry load.
- Follow detergent manufacturer's directions. The

amount required depends on type of detergent, load size and soil level, and water hardness.

5. If desired, add liquid bleach to Bleach Dispenser (some models).

- Before adding the wash load, add liquid bleach to bleach dispenser located in left front corner under the lid:
 - 3/4 cup (180 ml) for small loads
 - 1 cup (240 ml) for large loads
 - 1-1/4 cups (300 ml) for extra-large loads.
- Then add 1 cup (240 ml) water to flush the dispenser.

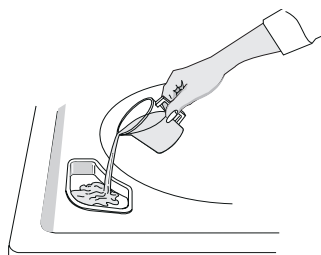

Bleach Dispenser (some models)

- Do not use powdered bleach in the bleach dispenser.

For models without a bleach dispenser, dilute the recommended amount of liquid chlorine bleach in 1 quart (.95 L) water. Add it to wash water after a few minutes of agitation. **Do not pour bleach directly on wash load.**

6. Add laundry load to washer.

- Dry load level should not be higher than top row of holes in wash tub.

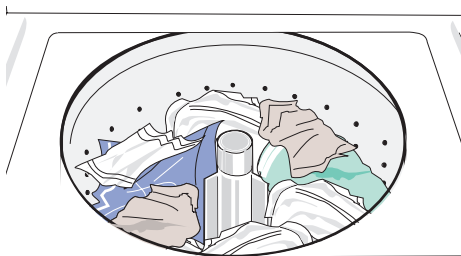

Do not load items above top row of holes in wash tub.

Do not overload washer.

- Do not put items on top of agitator or wrap them around it. Load items evenly.

- Combine large and small items in a load. Load large items first. Large items should not be more than half the total wash load.
- When washing a single heavy item, add 1 or 2 towels to balance the load.

7. If desired, add liquid fabric softener to Fabric Softener Dispenser (some models).

For models with a built-in dispenser

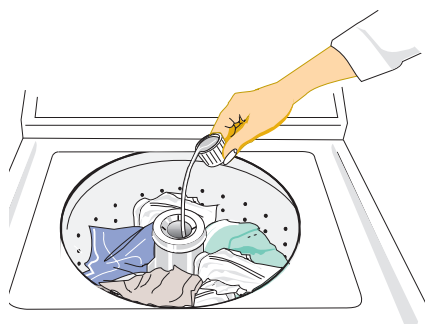

Built-In Fabric Softener Dispenser (some models)

1. Add liquid softener to the dispenser, following fabric softener label directions.
2. Add water to bring liquid level to fill line on dispenser cap.
3. Remove the dispenser from the agitator after each use. Rinse both cap and cup with warm water. Replace dispenser in the agitator.

NOTE: To separate cap from cup, put thumb into dispenser and push against side of cup.

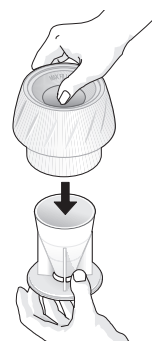

Built-In Fabric Softener Dispenser (some models)

After cleaning, push cap and cup firmly together. Replace dispenser by lining up the ribs and grooves and snapping it into position.

Fabric softener will be flushed from area under the built-in fabric softener dispenser when Large Load Water Level is selected. If a build-up of fabric softener occurs, clean with hot water. **DO NOT REMOVE SERVICE CAP.**

For models with a removable dispenser:

1. Attach fabric softener dispenser to top of agitator by pressing down gently.
2. Add softener to the dispenser, following fabric softener label directions.



Removable Fabric Softener Dispenser
(some models)

3. Add water to bring liquid level to top of the peg in the center of the cup.
4. Remove the dispenser from the agitator after each use. Rinse both lid and bowl thoroughly with warm water. Reassemble and place dispenser on agitator or store it nearby.

For models without a fabric softener dispenser, follow fabric softener label directions. Add diluted fabric softener to the final rinse. **Do not pour fabric softener directly on the wash load**

8. Set cycle selector knob and washer controls according to type, size, and soil level of each load, and detergent used.

9. Start the washer.

Close the washer lid and pull out the cycle selector knob. Washer will fill with the lid open. The tub will not agitate or spin unless the lid is closed.

- To stop the washer, push in the cycle selector knob.
- Do not stop and restart washer during a spin when using the fabric softener dispenser.
- To change a cycle, push in the cycle selector knob. Turn it clockwise to the desired setting. Pull out the knob to restart the washer.

10. Remove items when the cycle is completed.

For your safety, the lid locks when the tub is spinning. It will remain locked for about 1 minute after the tub stops spinning.

- To open the lid during a spin, push in the cycle selector knob and wait about 1 minute for the lid lock to release. Do not force open the locked lid.

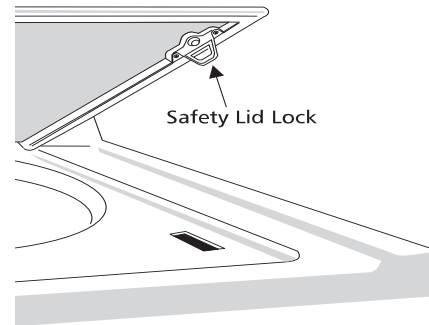

Place washed items in automatic dryer, line dry, or dry flat as directed by fabric care label. Excess wrinkling, color transfer or odors may develop in items left in the washer after the cycle has ended.

⚠ WARNING To avoid serious personal injury, do not operate washer if safety lid lock is missing or damaged.

Stain Removal

Safe Stain Removal Procedures

⚠ WARNING To reduce the risk of fire or serious injury to persons or property, comply with the basic warnings listed below:

- Read and comply with all instructions on stain removal products.
- Keep products in their original labeled containers and out of children's reach.
- Thoroughly wash any utensil used.
- Do not combine stain removal products, especially ammonia and chlorine bleach. Dangerous fumes may result.

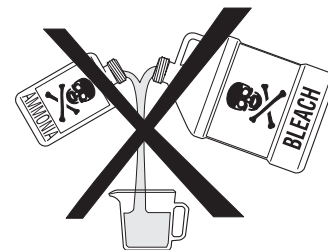

Do not combine stain removal products.

- Never wash items which have been previously cleaned in, washed in, soaked in or spotted with gasoline, dry cleaning solvents or other flammable or explosive substances because they give off vapors that could ignite or explode.
- Never use highly flammable solvents, such as gasoline, inside the home. Vapors can explode on contact with flames or sparks.
- Use cold water on unknown stains because hot water can set stains.
- Check care label instructions for treatments to avoid on specific fabrics.

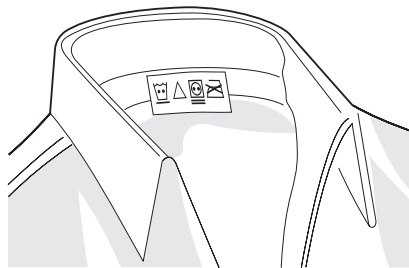

Follow fabric care label instructions.

For successful stain removal:

- Remove stains promptly.
- Determine the kind of stain, then follow recommended treatment in the stain removal chart on the next page.
- To pretreat stains, use a prewash product, liquid detergent, or a paste made from granular detergent and water.
- Check for colorfastness by testing stain remover on an inside seam.
- Rinse and wash items after stain removal.

Stain Removal

STAIN	TREATMENT
Adhesive tape, chewing gum, rubber cement.	Apply ice. Scrape off excess. Place stain face down on paper towels. Saturate with prewash stain remover or nonflammable dry cleaning fluid.
Baby formula, dairy products, egg.	Use product containing enzymes to pretreat or soak stains. Soak for 30 minutes or more. Wash.
Beverages (coffee, tea, soda, juice, alcoholic beverages).	Pretreat stain. Wash using cold water and bleach safe for fabric.
Blood.	Rinse with cold water. Rub with bar soap. Or, pretreat or soak with product containing enzymes. Wash using bleach safe for fabric.
Candle wax, crayon.	Scrape off surface wax. Place stain face down between paper towels. Press with warm iron until wax is absorbed. Replace paper towels frequently. Treat remaining stain with prewash stain remover or nonflammable dry cleaning fluid. Hand wash to remove solvent. Wash using bleach safe for fabric.
Chocolate.	Pretreat or soak in warm water using product containing enzymes. Wash using bleach safe for fabric.
Collar or cuff soil, cosmetics.	Pretreat with prewash stain remover or rub with bar soap.
Dye transfer on white fabric.	Use packaged color remover. Wash using bleach safe for fabric.
Grass.	Pretreat or soak in warm water using product containing enzymes. Wash using bleach safe for fabric.

STAIN	TREATMENT
Grease, oil, tar (butter, fats, salad dressing, cooking oils, car grease, motor oils).	Scrape residue from fabric. Pretreat. Wash using hottest water safe for fabric. For heavy stains and tar, apply nonflammable dry cleaning fluid to back of stain. Replace towels under stain frequently. Rinse thoroughly. Wash using hottest water safe for fabric.
Ink.	Some inks may be impossible to remove. Washing may set some inks. Use prewash stain remover, denatured alcohol or nonflammable dry cleaning fluid.
Mildew, scorch.	Wash with chlorine bleach if safe for fabric. Or, soak in oxygen bleach and hot water before washing. Badly mildewed fabrics may be permanently damaged.
Mud.	Brush off dry mud. Pretreat or soak with product containing enzymes.
Mustard, tomato.	Pretreat with prewash stain remover. Wash using bleach safe for fabric.
Nail polish.	May be impossible to remove. Place stain face down on paper towels. Apply nail polish remover to back of stain. Repeat, replacing paper towels frequently. Do not use on acetate fabrics.
Paint, varnish.	WATER BASED: Rinse fabric in cool water while stain is wet. Wash. Once paint is dry, it cannot be removed. OIL BASED AND VARNISH: Use solvent recommended on can label. Rinse thoroughly before washing.
Perspiration.	Use prewash stain remover or rub with bar soap. Rinse. Wash using nonchlorine bleach in hottest water safe for fabric.
Rust, brown or yellow discoloration.	For spots, use rust remover safe for fabric. For discoloration of an entire load, use nonchlorine bleach. Do not use chlorine bleach because it may intensify discoloration.
Shoe polish.	LIQUID: Pretreat with a paste of granular detergent and water. PASTE: Scrape residue from fabric. Pretreat with prewash stain remover or nonflammable dry cleaning fluid. Rinse. Rub detergent into dampened area. Wash using bleach safe for fabric.
Urine, vomit, mucus, feces.	Pretreat or soak in product containing enzymes. Wash using bleach safe for fabric.

Common Washing Problems

Many washing problems involve poor soil and stain removal, residues of lint and scum, and fabric damage. For satisfactory washing results, follow these suggestions provided by The Soap and Detergent Association.

PROBLEM	POSSIBLE CAUSES	SOLUTIONS	PREVENTIVE MEASURES
Blue stains	<ul style="list-style-type: none"> • Detergent or liquid fabric softener did not dissolve or disperse. 	<ul style="list-style-type: none"> • If caused by detergent, mix 1 cup (240 ml) white vinegar with 1 quart (.95 L) water in a plastic container. Soak item 1 hour. Rinse. • If caused by fabric softener, rub stains with bar soap. Wash. 	<ul style="list-style-type: none"> • Add detergent before wash load. Then start washer. • Dilute fabric softener with water.
Discoloration, graying	<ul style="list-style-type: none"> • Not enough detergent. • Wash water temperature too low. • Incorrect sorting. 	<ul style="list-style-type: none"> • Rewash with correct amount of detergent and hottest water safe for fabric. Add bleach safe for fabric. 	<ul style="list-style-type: none"> • Sort items by soil level and color. • Use correct amount of detergent, hottest water and bleach safe for fabric.
Greasy, oily stains	<ul style="list-style-type: none"> • Not enough detergent. • Undiluted liquid fabric softener poured directly on fabric. 	<ul style="list-style-type: none"> • Treat with prewash stain remover or liquid detergent. • Increase detergent and water temperature. Rewash. • Rub fabric softener stains with bar soap. 	<ul style="list-style-type: none"> • Use correct amount of detergent and hottest water safe for fabric. • Do not pour liquid fabric softener directly on fabric. See package directions or Washing Procedures for proper diluting.
Holes, tears, or snags	<ul style="list-style-type: none"> • Incorrect use of chlorine bleach. • Unfastened zippers, hooks, buckles. • Rips, tears and broken threads. • Overloading the washer. • Degradation of fabric. 	<ul style="list-style-type: none"> • May be irreversible if rips, tears and seams cannot be mended. 	<ul style="list-style-type: none"> • Never pour chlorine bleach directly on fabric. • Check condition of items before washing. See Washing Procedures for preparing and loading the wash load.
Lint	<ul style="list-style-type: none"> • Incorrect sorting. • Tissues left in pocket. • Overloading the washer. • Not enough detergent. • Undissolved detergent has left residue. • Static cling is attracting lint. • Load washed too long. 	<ul style="list-style-type: none"> • Reduce load size. Rewash using correct water temperature, water level, and amount of detergent. • Add nonprecipitating water conditioner to wash water. • Add liquid fabric softener to final rinse. • Dry load in dryer. • Remove lint with lint brush or roller. 	<ul style="list-style-type: none"> • See Washing Procedures for sorting and preparing the wash load. • Do not overload washer. • Use correct amount of detergent, water temperature and water level.

Common Washing Problems

Many washing problems involve poor soil and stain removal, residues of lint and scum, and fabric damage. For satisfactory washing results, follow these suggestions provided by The Soap and Detergent Association.

PROBLEM	POSSIBLE CAUSES	SOLUTIONS	PREVENTIVE MEASURES
Pilling (Fibers break off, ball up and cling to fabric)	<ul style="list-style-type: none"> •Pilling is normal with synthetic and permanent press fabrics. This is due to abrasion from normal wear. 	<ul style="list-style-type: none"> •Use a lint brush or shaver to remove pills. 	<ul style="list-style-type: none"> •Use fabric softener in the washer to lubricate fibers. •When ironing, use spray starch or fabric finish on collars and cuffs. •Turn items inside out to reduce abrasion.
Residue or powder on dark items; Stiff, harsh fabrics.	<ul style="list-style-type: none"> •Undissolved detergent. •Some nonphosphate granular detergents can combine with hard water minerals to form a residue. 	<ul style="list-style-type: none"> •Reduce load size. •Add dissolved detergent to tub . Rewash load. •Mix 1 cup (240 ml) white vinegar to 1 gallon (3.8 L) warm water in plastic container. Soak item. Rinse and rewash. 	<ul style="list-style-type: none"> •Increase water temperature using hottest water safe for fabric. •Do not overload washer. •Use liquid detergent or use nonprecipitating water conditioner with nonphosphate granular detergent.
Wrinkling	<ul style="list-style-type: none"> •Overloading the washer. 	<ul style="list-style-type: none"> •Reduce load size. •Rinse in cold water with liquid fabric softener. 	<ul style="list-style-type: none"> •Do not overload washer. •Remove items from washer as soon as cycle is completed. •Use liquid fabric softener.
Yellow buildup of body soil on synthetic fabrics	<ul style="list-style-type: none"> •Agitation time too short. •Wash water temperature too low. •Not enough detergent. 	<ul style="list-style-type: none"> •Soak in detergent booster or product containing enzymes. •Wash in hot water (120°F/ 49°C) using full permanent press cycle. Increase detergent. Add bleach safe for fabric. •Or, treat with color remover. 	<ul style="list-style-type: none"> •Wash synthetics frequently using water at least 100°F (37°C) and correct water level.
Yellow or brown rust stains	<ul style="list-style-type: none"> •Iron or manganese in water supply, water pipes, or water heater. 	<ul style="list-style-type: none"> •To restore discolored load of whites, use rust remover safe for fabric. Do not use chlorine bleach to remove rust stains. It may intensify discoloration. 	<ul style="list-style-type: none"> •Use nonprecipitating water softener. •Before washing, run hot water for a few minutes to clear lines. •Drain water heater occasionally. •For an ongoing problem, install an iron filter in your water supply system.

Care and Cleaning

CAUTION Use care with laundry products. They can damage finish on the washer.



Inside

- Remove items from the washer as soon as the cycle ends. Excess wrinkling, color transfer, and odors may develop in items left in the washer.
- Dry the washer top, the area around the lid opening, and the underside of the lid. These areas should always be dry before the lid is closed.
- Before cleaning the washer interior, **unplug the electrical power cord** to avoid electrical shock hazards.
- When extremely soiled items have been washed, a dirty residue may remain on the tub. Remove this by wiping the tub with a nonabrasive household cleanser. Rinse thoroughly with water.
- The agitator or tub may become stained from fabric dye. Clean these parts with a nonabrasive household cleanser. This prevents dye transfer to future loads.

Outside

- When washing is completed, wipe top and sides of washer with a damp cloth. Turn water faucets off to prevent pressure build-up in the hoses.
- As needed, clean the cabinet with mild soap and water. **Never use harsh, gritty or abrasive cleansers.** If top or lid becomes stained, clean with diluted chlorine bleach [1/2 cup (120 ml) in 1 quart (.95 L) water]. Rinse several times with clear water.
- Remove glue residue from tape or labels with a mixture of warm water and mild detergent. Or, touch residue with the sticky side of the tape or label.

- **Before moving the washer**, place a strip of cardboard or thin fiberboard under the front leveling legs to prevent floor damage.



Follow Winterizing Instructions for cold weather care.

Winterizing Instructions

If the washer is stored in an area where freezing can occur or moved in freezing temperatures, follow these winterizing instructions to prevent damage to the washer:

1. Turn off water supply faucets.
2. Disconnect hoses from water supply and drain water from hoses.
3. Plug electrical cord into a properly grounded electrical outlet.
4. Add 1 gallon nontoxic recreational vehicle (RV) antifreeze to empty wash tub. Close lid.
5. Set cycle selector knob at a spin setting. Pull out knob and let washer spin for 1 minute to drain out all water. Not all of the RV antifreeze will be expelled.
6. Push in knob, unplug electrical power cord, dry tub interior, and close lid.
7. Store washer in an upright position.
8. To remove antifreeze from washer after storage, run empty washer through a complete cycle using detergent. **Do not add wash load.**

Avoid Service Checklist Before calling for service, review this list. It may save both time and expense. The list includes common concerns that are not the result of defective workmanship or materials in this washer.

OCCURRENCE	POSSIBLE CAUSE	SOLUTION
NOISE		
"Clunking" or gear sounds.	A certain amount of "clunking" or gear sounds are normal in a heavy-duty washer.	This is normal.
Rattling and clanking noise.	Foreign objects such as coins or safety pins may be in tub or pump.	Stop washer and check tub. If noise continues after washer is restarted, objects may be in pump. Call your authorized servicer.
	Belt buckles and metal fasteners are hitting wash tub.	To prevent unnecessary noise and damage to tub, fasten fasteners and turn items inside out.
Squealing sound or hot rubber odor.	Washer is overloaded.	Do not overload washer. Stop washer and reduce load.
Thumping sound.	Heavy wash loads may produce a thumping sound.	This is usually normal. If sound continues, washer is probably out of balance. Stop washer and redistribute wash load.
Vibrating noise.	Washer is not resting firmly on floor.	Move washer so it rests firmly on floor. Adjust leveling legs. See INSTALLATION INSTRUCTIONS for details.
	Shipping bolt and block have not been removed during installation.	See INSTALLATION INSTRUCTIONS for removing shipping bolt and block.
	Wash load unevenly distributed in tub.	Stop washer and rearrange wash load.
OPERATING		
Washer does not start.	Electrical power cord may not be plugged in or connection may be loose.	Make sure plug fits tightly in wall outlet.
	House fuse blown, circuit breaker tripped, or a power outage has occurred.	Reset circuit breaker or replace fuse. Do not increase fuse capacity. If problem is a circuit overload, have it corrected by a qualified electrician. If problem is a power outage, call local electric company.
	Water supply faucets are not turned on.	Turn on water supply faucets.
	Cycle selector is not in correct position.	Move indicator clockwise slightly. Pull out knob.
	Motor is overheated.	Washer motor will stop if it becomes overheated. It will automatically restart after a cool down period of up to 30 minutes (if washer has not been manually turned off).

OCCURRENCE	POSSIBLE CAUSE	SOLUTION
Washer won't spin.	Lid is not completely closed.	Close lid completely.
Residue left in tub.	Heavily soiled items.	Wipe tub with a nonabrasive household cleanser, then rinse. Shake or brush excess dirt and sand from items before washing.
Wash load too wet after spin.	Washer is overloaded.	Do not overload washer. See Washing Procedures.
	Load is out of balance.	Rearrange load to allow proper spinning.
	Drain hose is kinked.	Straighten drain hose.
Water does not enter washer or it enters slowly.	Water supply is not adequate in area.	Check another faucet in the house. Wait until water supply and pressure increase.
	Water supply faucets are not completely open.	Fully open hot and cold faucets.
	Water is being used elsewhere in the house.	Water pressure must be at least 30 psi (260 kPa). Avoid running water elsewhere while washer is filling.
	Water inlet hoses are kinked.	Straighten hoses.
Water level does not cover load.	Improper water level selection (for models with water level/load size control).	Select higher water level/load size.
	Washer is overloaded.	Do not overload washer. When control is set at highest fill level, dry load level should not be higher than top row of circular holes in wash tub.
Warm or hot water is not hot enough.	Hot water heater is set too low or is a distance from washer.	Measure hot water temperature at nearby faucet with candy or meat thermometer. Water temperature should be at least 130°F (70°C). Adjust water heater as necessary.
	Hot water is being used elsewhere in the house.	Avoid using hot water elsewhere before or during washer use. There may not be enough hot water available for proper cleaning. If problem persists, your hot water system may be unable to support more than 1 use at a time.
Water in washer does not drain or drains slowly.	Drain hose is kinked or clogged.	Clean and straighten the drain hose.
Water leaks.	Fill hose connection at faucet or washer.	Check and tighten hose connections. Install rubber sealing washers provided.
	House drain pipes are clogged.	Unclog drain pipes. Contact plumber if necessary.
	Oversudsing.	Use less detergent.
Incorrect wash and rinse temperatures.	Hot and cold water hoses are	Connect hot water hose to hot water faucet and cold water hose to cold water faucet.
Water is entering washer but tub does not fill.		Standpipe must be a minimum of 33" (83.82 cm) high to prevent siphoning. See INSTALLATION INSTRUCTIONS.

FRIGIDAIRE GALLERY TOP LOAD WASHER WARRANTY (UNITED STATES)

SAMPLE WARRANTY ALWAYS USE THE WARRANTY
SUPPLIED WITH PRODUCTS

Your Frigidaire product is protected by this warranty

	WARRANTY PERIOD	FRIGIDAIRE, THROUGH ITS AUTHORIZED SERVICERS, WILL:	THE CONSUMER WILL BE RESPONSIBLE FOR:
FULL ONE-YEAR WARRANTY	One year from original purchase date.	Pay all costs for repairing or replacing any parts of this appliance which prove to be defective in materials or workmanship.	Costs of service calls that are listed under NORMAL RESPONSIBILITIES OF THE CONSUMER.*
LIMITED 2ND - 5TH YEAR WARRANTY	Second through fifth years from original purchase date.	Provide a replacement for a defective or malfunctioning part found in the washer transmission (illustrated below).	Costs for labor and replacement parts other than defective transmission parts.
FULL 25-YEAR INNER WASH BASKET WARRANTY (Excluding Alaska)	25 years from original purchase date.	Provide a replacement and in-home service labor, without charge, for an inner wash basket (illustrated below) that breaks due to defective materials or workmanship.	Costs of service calls that are listed under NORMAL RESPONSIBILITIES OF THE CONSUMER.*
LIMITED WARRANTY (Applicable to the State of Alaska)	Time periods listed above.	All of the provisions of the full and limited warranties above and the exclusions listed below apply.	Costs of the technician's travel to the home and any costs for pick up and delivery of the appliance required because of service.

Your appliance is warranted by Frigidaire Home Products, a division of White Consolidated Industries, Inc. We authorize no person to change or add to any of our obligations under this warranty. Our obligations for service and parts under this warranty must be performed by Frigidaire or an authorized Frigidaire servicer.

***NORMAL RESPONSIBILITIES OF THE CONSUMER**

This warranty applies only to products in ordinary household use, and the consumer is responsible for the items listed below:

1. Proper use of the appliance in accordance with instructions provided with the product.
2. Proper installation by an authorized servicer in accordance with instructions provided with the appliance and in accordance with all local plumbing, electrical and/or gas codes.
3. Proper connection to a grounded power supply of sufficient voltage, replacement of blown fuses, repair of loose connections or defects in house wiring.
4. Expenses for making the appliance accessible for servicing, such as removal of trim, cupboards, shelves, etc., which are not a part of the appliance when it was shipped from the factory.
5. Damages to finish after installation.
6. Replacement of light bulbs and/or fluorescent tubes (on models with these features).

EXCLUSIONS

This warranty does not cover the following:

1. CONSEQUENTIAL OR INCIDENTAL DAMAGES SUCH AS PROPERTY DAMAGE AND INCIDENTAL EXPENSES RESULTING FROM ANY BREACH OF THIS WRITTEN OR ANY IMPLIED WARRANTY.
Note: Some states do not allow the exclusion or limitation of incidental or consequential damages, so this limitation or exclusion may not apply to you.
2. Service calls which do not involve malfunction or defects in workmanship or material, or for appliances not in ordinary household use. The consumer shall pay for such service calls.
3. Damages caused by services performed by servicers other than Frigidaire or its authorized servicers; use of parts other than genuine Frigidaire Home Products parts; obtained from persons other than such servicers; or external causes such as abuse, misuse, inadequate power supply or acts of God.
4. Products with original serial numbers that have been removed or altered and cannot be readily determined.

Keep your bill of sale, delivery slip, or some other appropriate payment record. The date on the bill establishes the warranty period should service be required. If service is performed, it is in your best interest to obtain and keep all receipts. This written warranty gives you specific legal rights. You may also have other rights that vary from state to state. Service under this warranty must be obtained by contacting Frigidaire Home Products:

IF YOU NEED SERVICE

800 • 944 • 9044
Frigidaire Home Products
P.O. Box 212378
Augusta, GA 30917



Service Information (Canada)

To avoid unnecessary cost and inconvenience, make a few simple checks before calling for service. Common occurrences and their solutions can be found in the Avoid Service Checklist. Be sure you have followed the instructions in this manual.

If you are unable to locate the cause of a problem, call for service. Insist on factory service by an authorized FRIGIDAIRE HOME PRODUCTS PARTS AND SERVICE depot.

FRIGIDAIRE HOME PRODUCTS PARTS AND SERVICE

All Frigidaire appliances are backed by FRIGIDAIRE HOME PRODUCTS PARTS AND SERVICE, one of Canada's largest parts and service networks.

The Frigidaire reputation means you can enjoy complete professional service from one of our hundreds of trained technicians across the country. Ask your Frigidaire dealer for details about the Extended Service Plan offered by FRIGIDAIRE HOME PRODUCTS PARTS AND SERVICE to all purchasers of Frigidaire appliances in Canada.

FRIGIDAIRE HOME PRODUCTS PARTS AND SERVICE

7075 Ordan Drive
Mississauga, Ontario
L5T 1K6

Place the name, address and telephone number of your service depot in the spaces below.

Product and feature specifications as described or illustrated are subject to change without notice.



**WARRANTY (CANADA)
GALLERY AUTOMATIC WASHERS AND DRYERS**

WARRANTOR:

Frigidaire Home Products
7075 Ordan Drive
Mississauga, Ontario
L5T 1K6

For service under this warranty, contact your local dealer/retailer, authorized FRIGIDAIRE HOME PRODUCTS PARTS AND SERVICE depot, or:

FRIGIDAIRE HOME PRODUCTS PARTS & SERVICE

7075 Ordan Drive
Mississauga, Ontario
L5T 1K6
Tel.: (905) 565-9200
Fax: (905) 565-0937

WARRANTY PERIOD:

For the first two years after purchase by the original consumer/owner:

Lifetime washer, after purchase by the original consumer/owner:

Top load automatic washers only: transmission for the third through tenth year after purchase by the original consumer/owner:

WARRANTOR WILL THROUGH ITS AUTHORIZED SERVICE DEPOT:

Pay all costs to repair or replace any defective parts.

Pay all costs (excluding labour to install) of a polypropylene washer basket and/or polypropylene tub.

Pay all costs (excluding labour to install) to replace any defective transmission.

WARRANTY APPLIES TO:

- a) Products purchased and installed in Canada for personal single family household use.
- b) Defects resulting or arising out of the manufacturing process.
- c) Products bearing legible manufacturer's model and serial numbers.
- d) Replacement parts only for the remainder of the original warranty.

WARRANTY DOES NOT APPLY TO:

- a) Transportation damage.
- b) Supply and replacement of porcelain, fuses, glass and light bulbs.
- c) Parts and service supplied or obtained from other than FRIGIDAIRE HOME PRODUCTS PARTS AND SERVICE or FRIGIDAIRE HOME PRODUCTS PARTS AND SERVICE authorized depots.
- d) Damage or failure as the result of abuse, improper or commercial use.

CONSUMER/OWNER RESPONSIBILITY:

- a) To provide proof of the original date of purchase by means of a bill of sale or payment record verifying purchase date.
- b) To pay all costs to make the appliance readily accessible for service.
- c) To ensure proper power supply and connection of the appliance to same.
- d) Proper installation, control setting and care of finish.

This warranty is in addition to any statutory warranties contained in any applicable legislation. The terms and conditions of this warranty are not intended to exclude or limit your rights under those statutes. The warrantor however reserves the right to charge transportation and travelling costs for distances in excess of 48 kilometres (30 miles) from the nearest FRIGIDAIRE HOME PRODUCTS PARTS AND SERVICE authorized service depot. This warranty plus the statutory warranties mentioned are the only warranties given to the consumer/owner for this product.

SECTION C - INSTALLATION INSTRUCTIONS

Full Size Automatic Washer

Before beginning installation, carefully read these instructions. This will simplify the installation and ensure the washer is installed correctly and safely. Leave these instructions near the washer after installation for future reference.

NOTE: The electrical service to the washer must conform with local codes and ordinances and the latest edition of the National Electrical Code, ANSI/NFPA 70, or in Canada, CSA 22.1 Canadian Electrical Code Part 1.

PRE-INSTALLATION REQUIREMENTS

Tools Required for Installation:

1. 3/8 in. socket with ratchet.
2. Channel-lock adjustable pliers.
3. Carpenter's level.

ELECTRICAL REQUIREMENTS

CIRCUIT - Individual, properly polarized and grounded 15 amp. branch circuit fused with 15 amp. time delay fuse or circuit breaker.

POWER SUPPLY - 2 wire, with ground, 120 volt, single phase, 60 Hz, Alternating Current.

OUTLET RECEPTACLE - Properly grounded 3-prong receptacle to be located so the power supply cord is accessible when the washer is in an installed position.

GROUNDING REQUIREMENTS

⚠ WARNING Improper connection of the equipment grounding conductor can result in a risk of electrical shock. Check with a licensed electrician if you are in doubt as to whether the appliance is properly grounded.

1. The washer **MUST** be grounded. In the event of a malfunction or breakdown, grounding will reduce the risk of electrical shock by a path of least resistance for electrical current.
2. Since your washer is equipped with a power supply cord having an equipment-grounding conductor and a grounding plug, the plug **MUST** be plugged into an appropriate, copper wired receptacle that is properly installed and grounded in accordance with all local codes and ordinances or in the absence of local codes, with the National Electrical Codes, ANSI/NFPA 70 (latest edition). If in doubt, call a licensed electrician. **DO NOT** cut off or alter

the grounding prong on the power supply cord. In situations where a two-slot receptacle is present, it is the owner's responsibility to have a licensed electrician replace it with a **properly grounded** three prong grounding type receptacle.

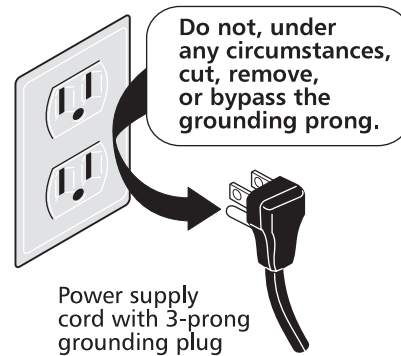

3. For added personal safety, connect a separate ground wire (No. 18 minimum) from a top panel hinge screw on the rear of the washer to a grounded cold water pipe. **DO NOT** ground to a gas supply pipe or hot water pipe.
4. Grounded cold water pipe **MUST** have metal continuity to electrical ground and **MUST** register no more than 25 ohms resistance. It **MUST** not be interrupted by plastic, rubber, or other electrical insulating connectors such as hoses, fittings, washers, gaskets (including water meter or pump). Any electrically insulated connector should be jumped with a length of No. 4 copper wire securely clamped to bare metal at both ends with a UL approved ground clamp.
5. If a grounded water pipe is not available, a ground rod **MUST** be used and register no more than 25 ohms resistance when in the ground. Drive the rod into the ground outside the dwelling and connect a grounding wire (12 AWG or heavier) between the grounding screw and the grounding rod. It may take more than one ground rod to not exceed 25 ohms resistance to ground.

WATER SUPPLY REQUIREMENTS

Hot and cold water faucets **MUST** be installed within 42 inches (107 cm) of your washer's water inlet. The faucets **MUST** be 3/4 inch (1.9 cm) garden hose type so inlet hoses can be connected. Water pressure **MUST** be between 10 and 120 pounds per square inch (maximum unbalance pressure, hot vs. cold, 10 psi.) Your water department can advise you of your water pressure. The hot water temperature should be about 140 degrees F (60 degrees C).

DRAIN REQUIREMENTS

1. Drain capable of eliminating 17 gallons (64.3 L) per minute.
2. A standpipe diameter of 1-1/4 in. (3.18 cm) minimum.
3. The standpipe height above the floor should be:
Minimum height: 33 in. (83.82 cm)
Maximum height: 96 in. (244 cm)
2. In an area where it will come in contact with curtains or drapes.
3. In an area (garage or garage-type building) where gasoline or other flammables are kept or stored (including automobiles).
4. On carpet. Floor **MUST BE SOLID** with a maximum slope of 1 in. (2.54 cm). To ensure vibration or movement does not occur, **REINFORCEMENT** of the floor may be necessary.

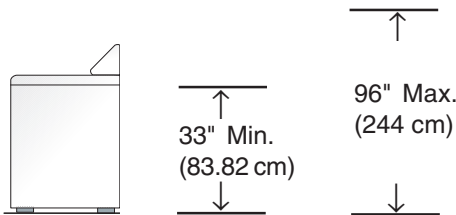

NOTE: For installations requiring a longer drain hose, have a qualified technician install a longer drain hose, P/N 131461201, available from an authorized parts distributor. For drain systems in the floor, install a syphon break kit, available from your local hardware store.

IMPORTANT MINIMUM INSTALLATION CLEARANCES

When installed in alcove: Sides = 0" (0 cm), Rear = 0" (0 cm), Top = 20" (50.8 cm).

When installed in closet: Sides = 0" (0 cm), Rear = 0" (0 cm), Top = 20" (50.8 cm), Front = 1" (2.54 cm).

Closet door ventilation required: 2 louvered openings each 60 square inches (387 cm²) — 3 inches (7.6 cm) from bottom and top of door.

UNPACKING

1. Using the four shipping carton corner posts (two on each side), carefully lay the washer on its left side and remove foam shipping base.
2. Using a ratchet with 3/8" socket, remove the mechanism shipping bolt and plastic spacer block from the center of the base.

NOTE: If the washer is to be transported at a later date, the tub blocking pad, shipping bolt, and plastic spacer block should be retained.

ROUGH-IN DIMENSIONS

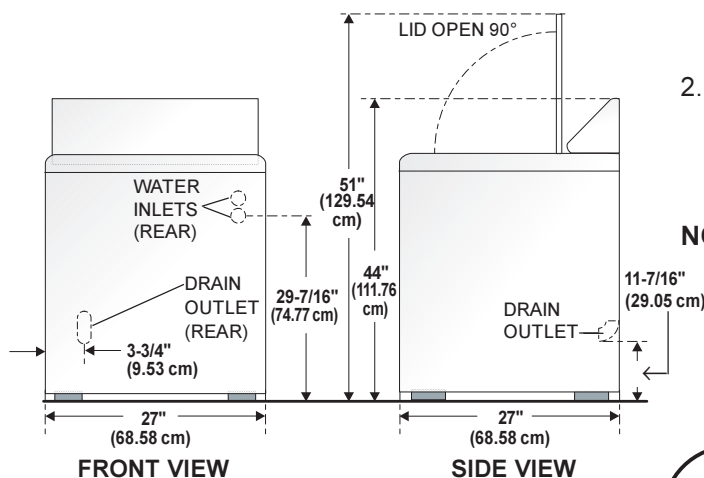

LOCATION OF YOUR WASHER

DO NOT INSTALL YOUR WASHER:

1. In an area exposed to dripping water or outside weather conditions. The ambient temperature should never be below 60 degrees F (15.6 degrees C) for proper washer operation.

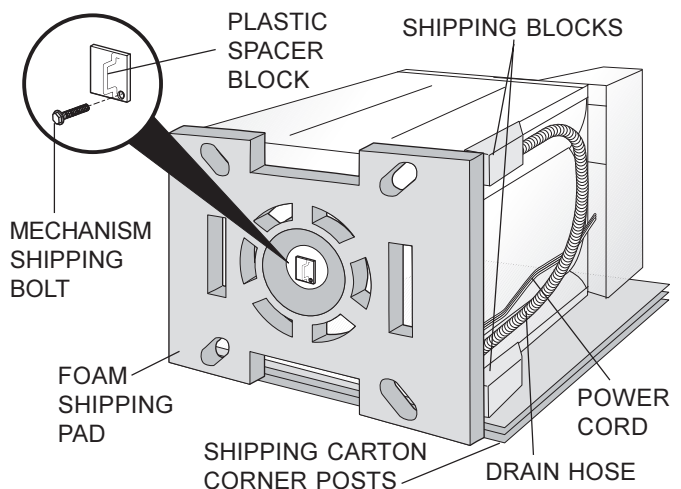

3. Return the washer to an upright position.
4. Remove the tape holding the lid shut and open the lid.
5. Remove the foam tub blocking pad.
6. Remove the inlet hoses and enclosure package from the tub.
7. From the back of the washer, remove only the **WIRE** shipping clips that secure the drain hose to the left side of the washer backsheet. **DO NOT REMOVE THE PLASTIC CLAMPS** on the right side of the washer. These clamps form a standpipe to prevent water siphoning.
8. Carefully move the washer to within 4 feet of the final location for the start of the installation.

INSTALLATION

1. Run some water from the hot and cold faucets to flush the water lines and remove particles that might clog up the water valve screens.
2. Remove the inlet hoses and rubber washers from the plastic bag and install the rubber washers in each end of the inlet hoses.

3. Carefully connect the inlet hose marked "HOT" to the bottom outlet of the water valve. Tighten by hand, then tighten another 2/3 turn with pliers. Carefully connect the other inlet hose to the top outlet of the water valve. Tighten by hand, then tighten another 2/3 turn with pliers.



⚠ CAUTION DO NOT CROSS THREAD OR OVERTIGHTEN THESE CONNECTIONS.

4. Determine which water faucet is the **HOT** water faucet and carefully connect the bottom inlet hose to the **HOT** water faucet, tighten by hand, then tighten another 2/3 turn with pliers. Carefully connect the top inlet hose to the **COLD** water faucet, tighten by hand, then tighten another 2/3 turn with pliers.

⚠ CAUTION DO NOT CROSS THREAD OR OVERTIGHTEN THESE CONNECTIONS.

Turn the water on and check for leaks at both connections.

5. Carefully move the washer to its final location.

6. To ensure the washer is level and solid on all four legs, open the lid, grasp the top panel and tilt the washer forward so the rear legs are off the ground. Gently set the washer back down to allow the rear legs to self adjust. Place a level on top of the washer. Check it side to side, then front to back. Screw the front leveling legs up or down to ensure the washer is resting solid on all four legs (no rocking of the washer should exist).

NOTE: Keep the leg extension at a minimum to prevent excessive vibration. The farther out the legs are extended the more the washer will vibrate.

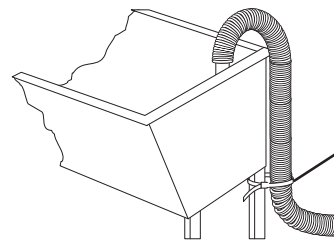
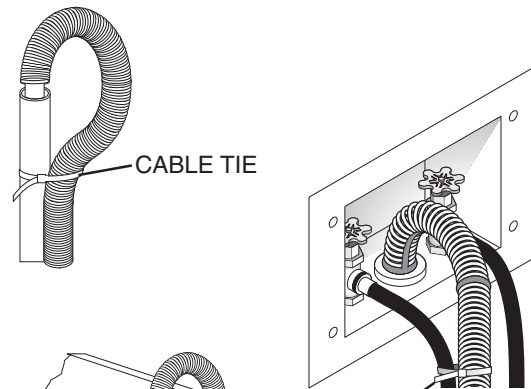

7. Form a "U" shape on the end of the drain hose with the hose pointed toward the drain. Place the formed end in a laundry tub or a standpipe and secure with a cable tie provided in the enclosure package.

NOTE: The standpipe inside diameter must be 1-1/4" (3.18 cm) minimum. There must be an air gap around the drain hose in the standpipe. A snug hose fit can cause a siphoning action.

8. Plug the power cord into a grounded outlet.

NOTE: Check to ensure the power is off at a circuit breaker/fuse box before plugging the power cord into an outlet.

9. Turn on the power at a circuit breaker/fuse box.
10. Read the Operating Instructions and Owner's Guide provided with the washer. They contain valuable and helpful information that will save you time and money.

11. Run the washer through a complete cycle. Check for water leaks and proper operation.
12. If your washer does not operate, please review the "Avoid Service Checklist" located in your Owner's Guide before calling for service.
13. Place these instructions in a location near the washer for future reference.

NOTE: A wiring diagram is located inside the washer console.

REPLACEMENT PARTS

UNITED STATES

If replacement parts are needed for your washer, contact the source where you purchased your washer or call

1-800-944-9044 for the Frigidaire Company Authorized Parts Distributor nearest you.

CANADA

If replacement parts are needed for your washer, contact your local dealer/retailer or call (905) 565-9200 for the authorized Frigidaire Parts and Service depot nearest you.

⚠ WARNING Destroy the carton and plastic bags after the washer is unpacked. Children might use them for play. Cartons covered with rugs, bedspreads, or plastic sheets can become airtight chambers causing suffocation. Place all materials in a garbage container or make materials inaccessible to children.

⚠ WARNING The instructions in this manual and all other literature included with this washer are not meant to cover every possible condition and situation that may occur. Good safe practice and caution **MUST** be applied when installing, operating and maintaining any appliance.

Maximum benefits and enjoyment are achieved when all the Safety and Operating instructions are understood and practiced as a routine with your laundering tasks.

SECTION D - PARTS LOCATION AND THEIR FUNCTION

Timer

The timer is located in the console and controls electrical power to the components of the washer.

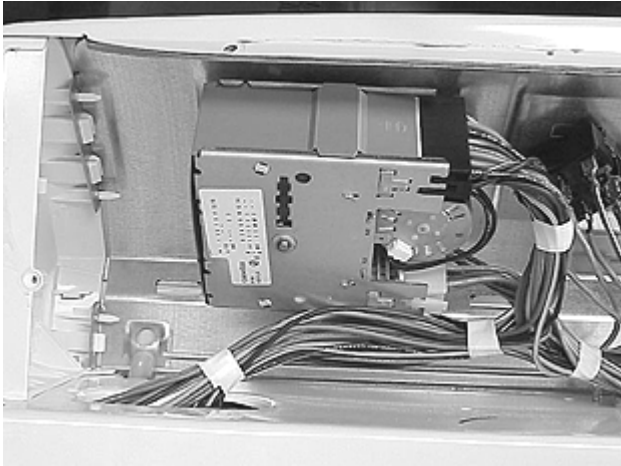

The timer is made up of a motor driven spool that advances one increment a minute whenever electrical power is applied to the motor.

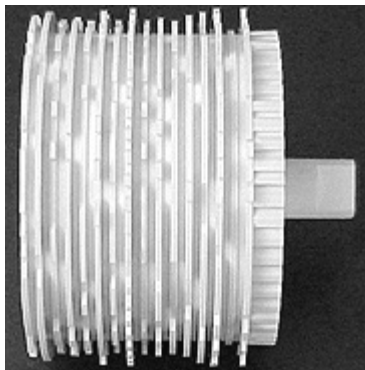

The spool has 14 cams that open and close the 24 contacts and supply electric power to components at the correct time in the cycle.

To help determine when each set of contacts are closed, a timer cycle chart is provided with each washer. (A sample timer cycle chart is shown on the following page.) The first column of the chart is titled CAM. In this column are numbers 0 to 14 that equate to the number of cams starting at the rear of the timer. The next two columns are titled TERM for terminals and are identified as ACTIVE and FIXED. The active terminals are the terminals that are moved by the cams, the fixed terminals are the ones that the do not move. The active terminals are usually the terminals that have

power applied to them with the fixed terminals connected to the components that power is being applied to. The next column is titled CONTACT and identified as T for the top contacts of the fixed terminals and B for the bottom contacts of the fixed terminals. The next column is titled CIRCUIT and indicates the circuit controlled by the cam, terminals and contacts. For example, CAM 10, ACTIVE terminal 17, FIXED terminal 18, and CONTACT B controls the drain pump circuit at specific times. Each circuit has a horizontal line extending across the timer chart. The remaining columns make up the wash cycles and are connected by vertical lines below to the step time in minutes and the step number. When the boxes formed by the horizontal lines from the circuit and the vertical lines step time are filled in, this indicates that electrical power is applied to that circuit at that time in the cycle.

IMPORTANT NOTE: Only the cam number and contact are called out on the schematic and wiring diagram.

Speed combination switch

The speed combination switch is located in the console and allows the user to select combinations of agitation and spin speeds. When a speed combination is set, depending on the model, two of either 3 or 5 sets of contacts close completing the circuit to one of the motor's run windings.

SPEED SWITCH CIRCUIT					
AGIT/SPIN	1-5	1-4	2-4	2-5	1-3
N/F	X			X	
G/F		X		X	
G/S		X	X		
EG/S			X		X

N=NORMAL F=FAST EG=EXTRA GENTLE
G=GENTLE S=SLOW

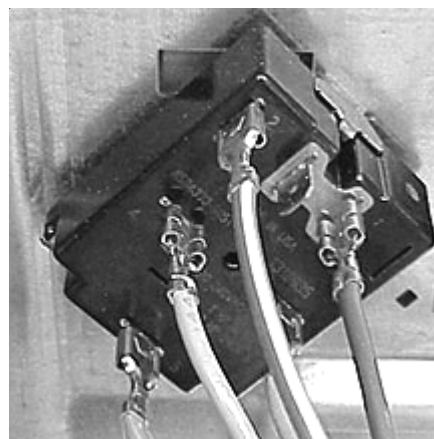

SAMPLE TIMER CYCLE CHART

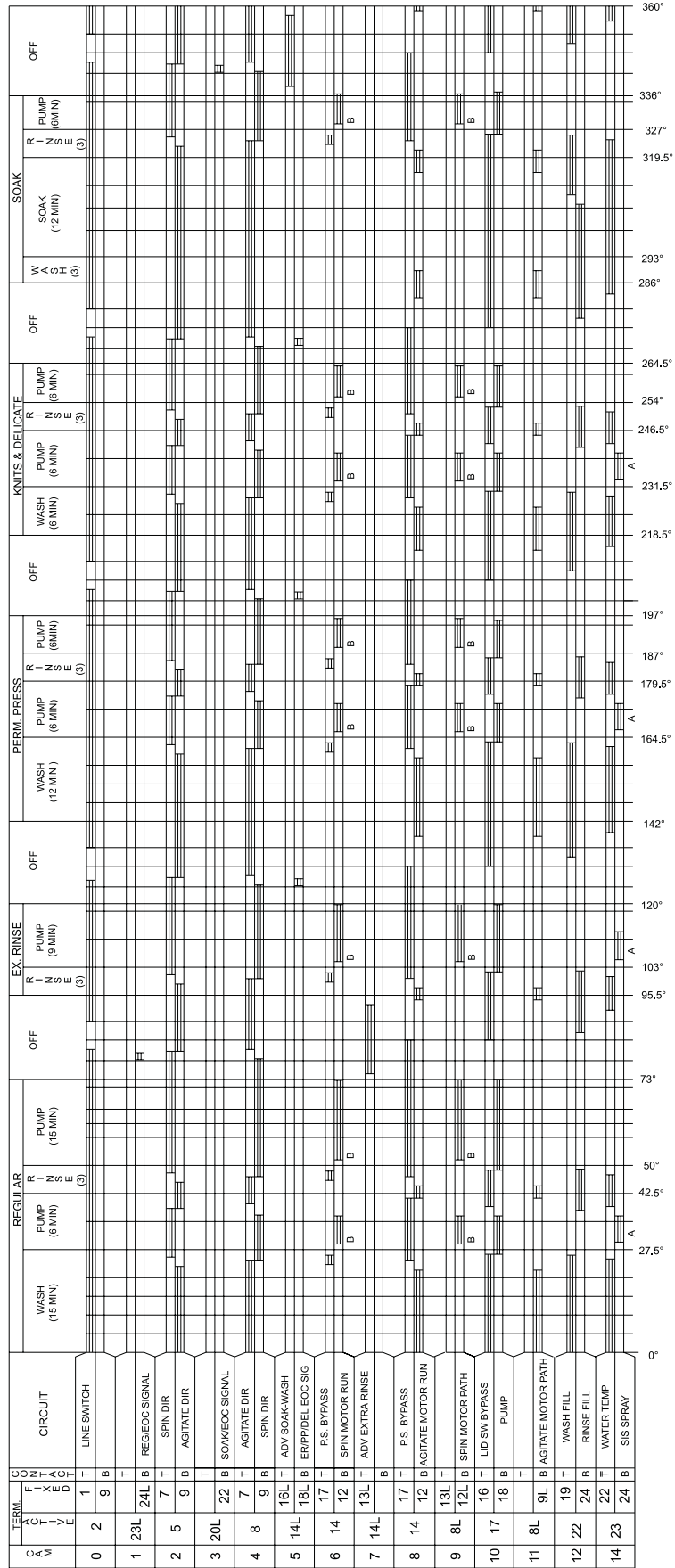

Pressure switch assembly

The pressure switch is located in the console.

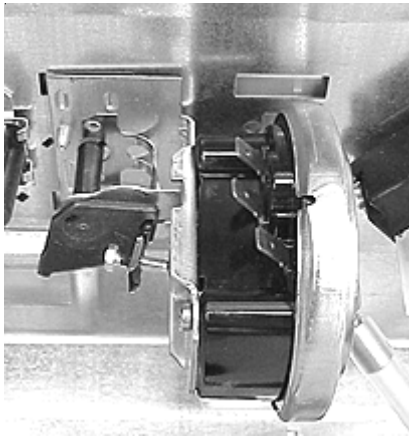

It is made up of a knob and gear assembly that allows the user to adjust the water level in the tub, an adjustable pressure switch and plastic tubing that connects the pressure switch to the outer tub. When the tub does not have water in it, the air in the plastic tubing is at atmospheric pressure and the spring in the pressure switch holds contacts 1 to 2 closed, completing the circuit to the water valves. As water enters the tub the air in the tube is compressed. When pressure in the tube exceeds the pressure of the spring in the pressure switch, the contact of the pressure switch changes from 1 to 2 to 2 to 3 turning off the water valves and supplying power to the motor circuit.

Wash cycle options switch (some models)

The wash cycle options cycle switch is located in the console.

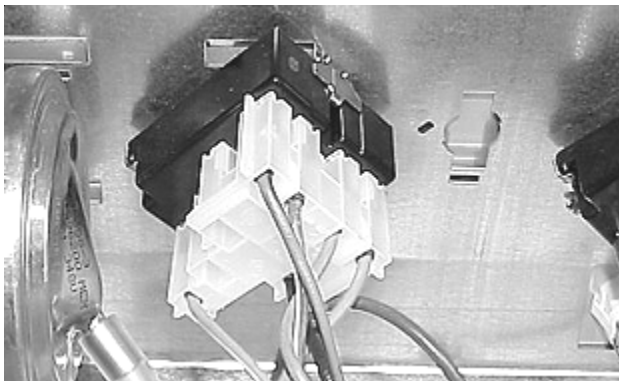

OPTION SWITCH					
POS	OPTION	1-9	1-3	5-4	5-2
1	POWER SCRUB/ EXTRA RINSE			X	X
2	EXTRA RINSE	X		X	
3	POWER SCRUB		X		X
4	OFF	X	X		

X=SWITCH CLOSED

The wash cycle options feature allows the user to set combinations of POWER SCRUB, REGULAR WASH AND EXTRA RINSE cycles and have the cycles run continuously. The contacts of the switch bypass the OFF position between these cycles so the timer advances from one cycle to another without stopping.

Wash/rinse temperature switch

The wash/rinse temperature switch is located in the console.

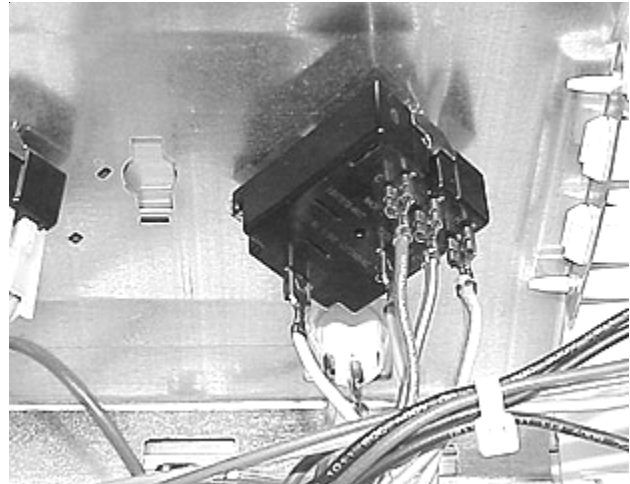

The wash/rinse temperature switch allows the user to select the water temperature in the wash and rinse cycles. The switch controls the water temperature by supplying power to the hot and cold solenoids of the water valve, and in some models, the auto temperature control.

The switch has 2 input terminals that receive power from the timer. Two output terminals (on models without the auto temp feature) are connected to the hot and cold solenoids of the water valve. If the model has the auto temp feature the switch has a third output terminal supplying power to the auto temp control.

TEMPERATURE SWITCH CIRCUIT				
WASH/RINSE	F-H	FF-H	FF-C	F-D
H/C	X			
W/C	X		X	
C/C			X	
W/W		X	X	
R C/C			X	X
R W/C	X			X
R W/W		X		X

H=HOT R=REGULATED
C=COLD
W=WARM

Auto temp system

The auto temp system is made up of the auto temp control, mounted to the left end cap of the console and a positive thermal sensor connected in the water hose between the water valve and the water inlet.

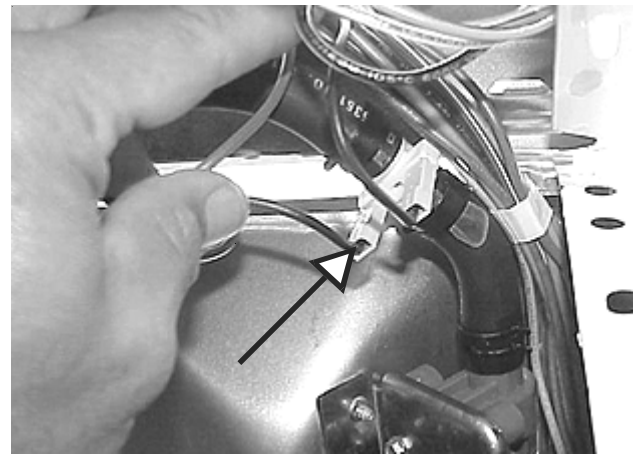
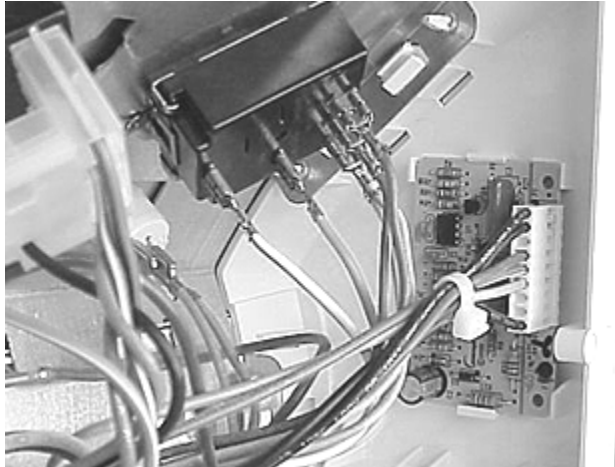

When the temp selector switch is set to regulated cold/ cold, electrical power is supplied to the cold water solenoid by contacts FF and C of the temperature selector switch. The auto temperature control cycles the hot water solenoid using the information received from the sensor to control the wash water temperature to 70 +/- 5 degrees F.

End of cycle signal switch

The end of cycle signal switch is located in the console.

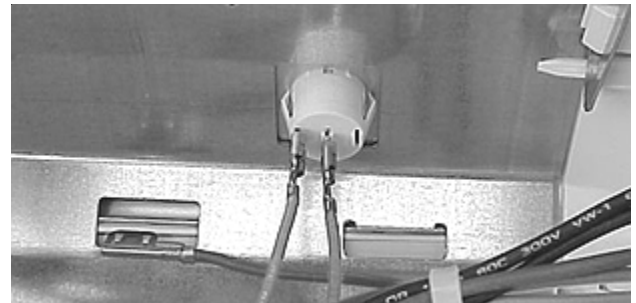
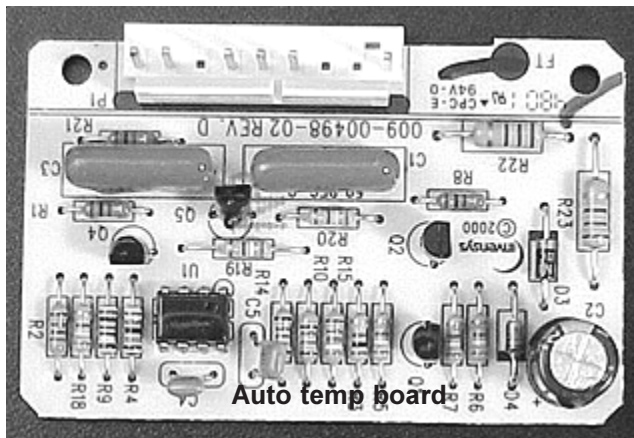

The switch controls power to the end of cycle signal which allows the user to turn end of cycle signal off or on.

End of cycle signal

The end of cycle signal is mounted to the control mounting panel in the console.

When the temperature selector switch is set to regulated warm/warm, electrical power is supplied to the hot water solenoid by contacts FF and H of the temperature selector switch. The auto temperature control cycles the cold water solenoid using the information received from the sensor to control the wash water temperature to 90 +/- 5 degrees F.

When the temperature selector switch is set to regulated warm/cold, electrical power is supplied to the hot water solenoid by contacts F and H of the temperature selector switch. The auto temperature control cycles the cold water solenoid using the information received from the sensor to control the wash water temperature to 90 +/- 5 degrees F.

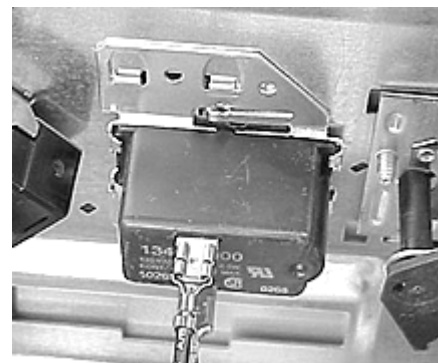

When the cycle is over and the lid is unlocked the signal sounds for 3 to 5 seconds to notify the user that the cycle is complete.

Lid lock assembly

The lid lock assembly is a safety device that removes power from the motor circuits when the lid is lifted during agitation and locks the lid to prevent it from being opened during the spin cycle. The lid lock assembly is mounted to the bottom of the top panel and locks the lid by moving a locking arm through the lid strike.

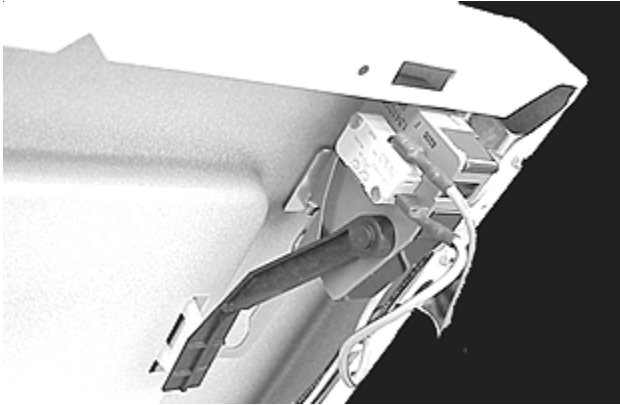

Softener dispenser

The softener dispenser is mounted on the top of the agitator on 2.7 cu. ft. models and in the agitator on 3.0 cu. ft. models.



The liquid fabric softener remains in the dispenser during the wash cycle. During the first spin cycle, the softener moves from the dispenser to the outer cavity of the dispenser or agitator and is held in place by centrifugal force until the end of the spin cycle.

The softener is then dispensed into the tub during the rinse fill portion of the wash cycle.

Agitator

The agitator is located in the center of the inner tub

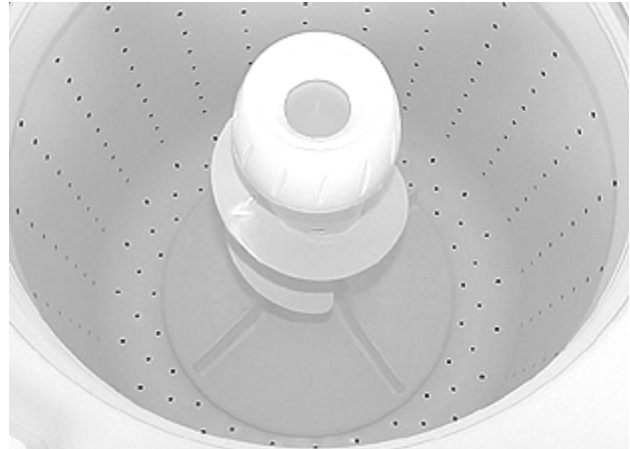

The agitator is driven by the shaft of the transmission and rotates back and forth to move the clothes through the water. Some models are equipped with dual action agitators where the bottom half of the agitator moves back and forth and the top rotates in one direction.

Bleach dispenser

The bleach dispenser has two parts. One part is mounted in the top panel where liquid bleach is added.

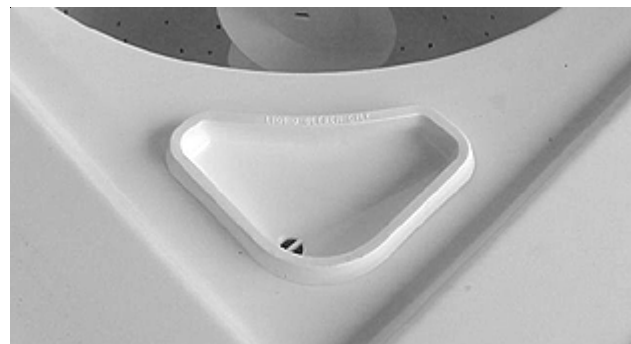

The second part is molded into the splasher shield and dispenses the bleach between the tub and the spin basket. The spin basket prevents the bleach from getting on the clothes until the bleach is mixed with the fill water.

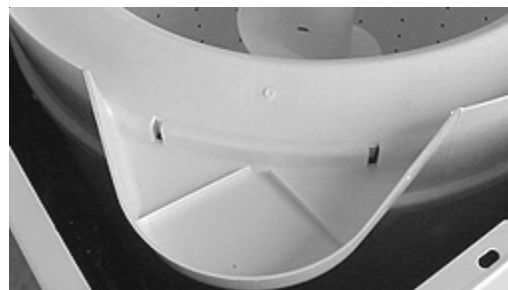

Water inlet valve

The water valve is mounted to the rear panel under the main top in the right-hand side.

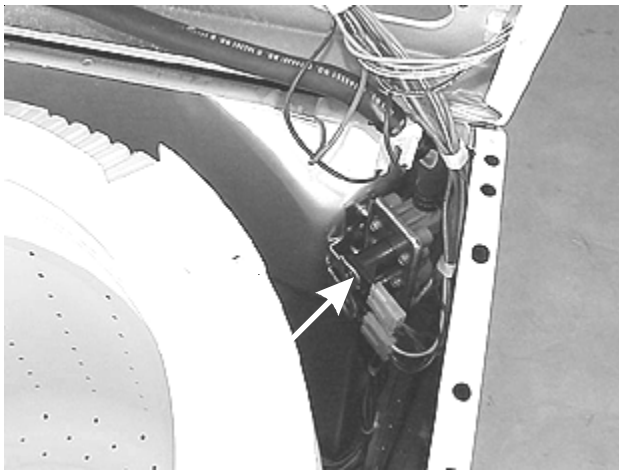

The water inlet valve is actually two solenoid operating valves in one body - a hot water valve and a cold water valve that discharge into a common mixing chamber. The flow of water out of the chamber is controlled by a molded in flow washer capable of maintaining a flow rate of 3.0 - 14.6 gallons per minute, with incoming water pressure of 30 to 120 P.S.I. The inlet valve is controlled by the timer and water temperature selector switch, individually or together, to provide hot, cold, or warm water for washing and cold or warm water for rinsing. The temperature of the warm mixture will be dependent upon the temperature and pressure of the hot and cold water supply lines or the auto temp control.

Valve operation

Both inlet solenoid valves are identical in construction and operation. The valve body provides an air passage with a large orifice and seat where the water can be stopped. The outlet of the valve body empties into the mixing chamber. A moveable rubber diaphragm operates against the valve seat to start and stop the flow of water. The diaphragm is operated by water pressure. It has a small bleed orifice outside the seat contact area, and a large main orifice at its center. The armature of the solenoid serves to open and close the main orifice. The armature operates within a closed metal tube (valve guide) which is sealed by the outer edge of the diaphragm to the valve body. A coil spring holds the armature down against the diaphragm main orifice when the solenoid is not energized.

The following line drawings and text explains basic valve operation.

When the valve is in a closed position, the solenoid is not energized. Water has bled through the diaphragm bleed orifice placing incoming line pressure on top of the diaphragm. The bottom of the diaphragm is essentially at atmospheric pressure (open to the outlet) and the pressure differential holds the valve shut.

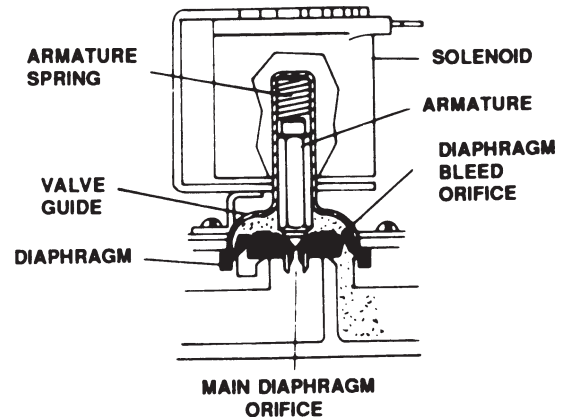

Water Valve Closed

When the solenoid is energized, the resulting magnetic field pulls the armature up into the valve guide. The armature spring is compressed by this action. When the armature moves up, it allows the water on the top of the diaphragm to drain through the main orifice.

The diaphragm bleed orifice is much smaller than the main orifice and will not admit enough water to maintain pressure on the top side of the diaphragm. Thus, as the pressure on the top of the diaphragm is reduced to almost zero, the pressure on the bottom lifts the diaphragm off the valve seat, allowing a full flow of water.

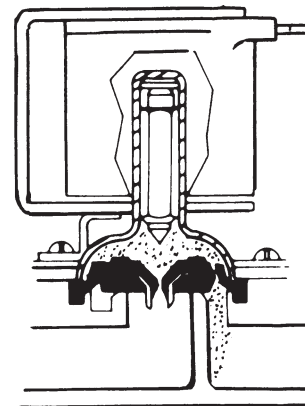

Solenoid Activated

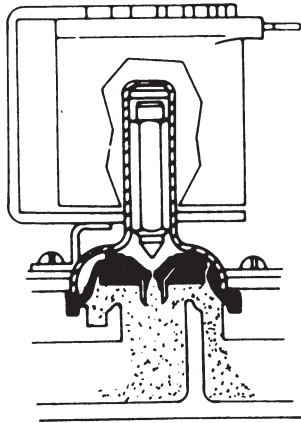

Water Valve Open and Diaphragm Up

When the solenoid is de-energized, the armature drops down, closing the diaphragm main orifice. Water continues to flow through the diaphragm bleed orifice, equalizing the pressure and allowing the spring to push the diaphragm down against the valve seat.

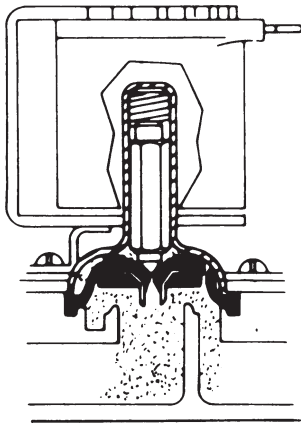

Water Valve Closing

Drain pump

The drain pump is mounted in the left front corner of the washer base.

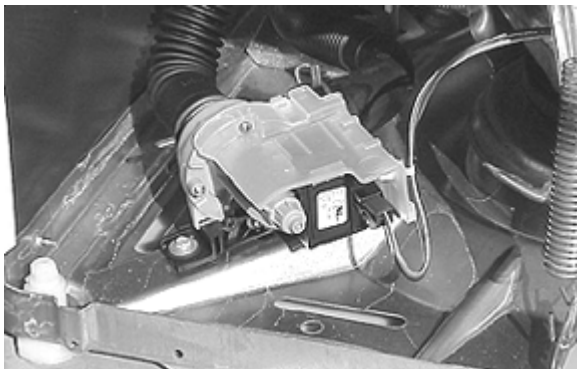

It operates on 120 VAC and is controlled by the timer. The pump out specifications of the drain pump vary from 12 G.P.M with a 3 foot standpipe height to 7 G.P.M. with a 8 foot standpipe height.

The motor

The motor is mounted to transmission mounting plate, which is part of the leg and dome assembly, and is located at the right front under the tub.

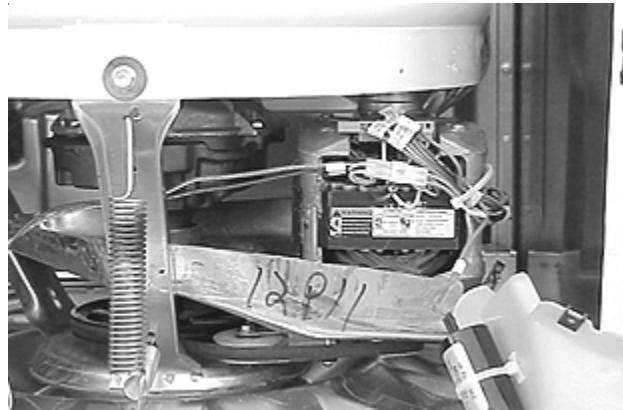

The motor is a capacitor start, bi-directional motor. Depending on the model, it is either 1/2 or 3/4 HP with from 1 to 3 speeds. The motor drives the transmission by a belt. When the motor turns clockwise the transmission agitates. When the motor turns counterclockwise the transmission spins.

Transmission

The top of the transmission is centered in the outer tub by a bearing and seal assembly. The bottom of the transmission mounts to the transmission mounting plate by bolts through the bearing block .

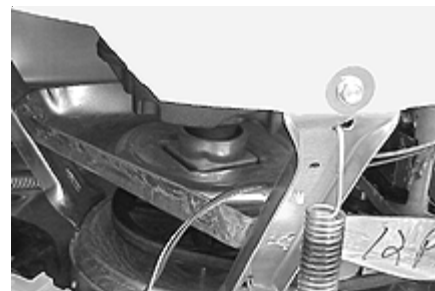

The agitator shaft of the transmission is connected to the agitator. When the pulley on the transmission is turned clockwise the gears inside the transmission cause the shaft to oscillate back and forth. Simultaneously, the one-way bearing located at the base of the transmission locks to prevent turning of the transmission and spin basket.

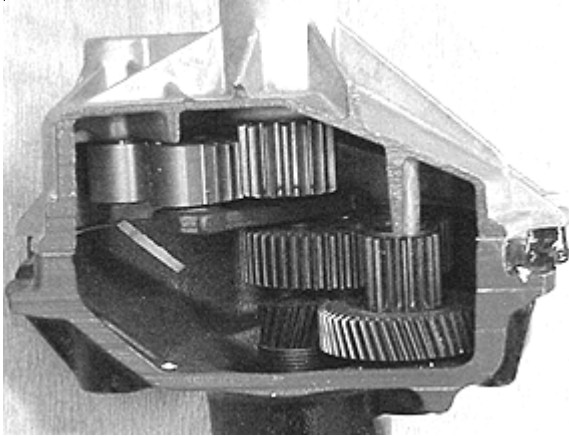

The spin basket is fastened to the spin shaft of the transmission. When the pulley on the transmission is turned counterclockwise, a small spring inside the transmission tightens around the input shaft causing the transmission and spin basket to turn. Simultaneously, the one-way bearing located at the base of the transmission slips to allow turning of the transmission and the spin basket.

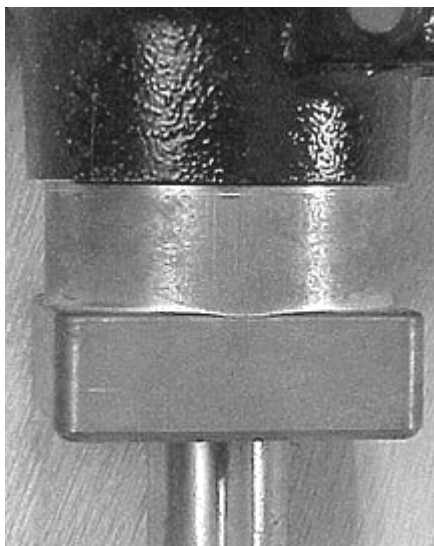

Spin basket or inner tub

The spin basket is mounted to the top of the transmission.

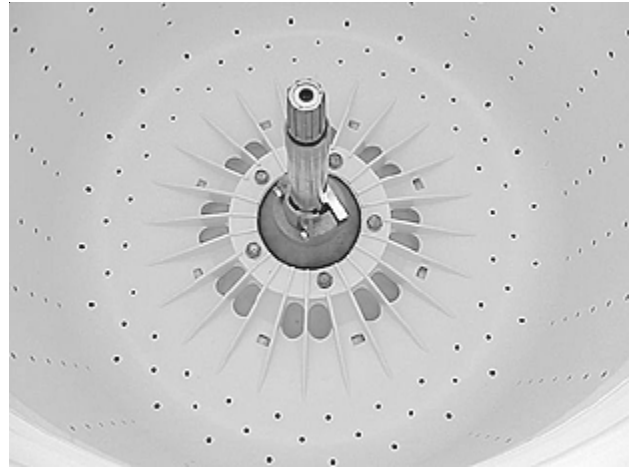

The spin basket holds the clothes. During the wash cycle the movement of the agitator draws water up through the lint screen filter in the bottom of the spin basket and forces it out the holes in the side and the bottom. As the water circulates lint is trapped on the under side of the filter screen. During the drain cycle the water is drawn down through the filter screen flushing the lint out the drain. Because of the one way bearing at the bottom of the transmission and the movement of the agitator, the spin basket rotates or indexes during the agitation cycle. Molded into the top of the spin basket is a liquid filled ring that works as a counter balance during the spin cycle to reduce vibration.



Splash tub cover

The splash tub cover snaps to the top of the outer tub and prevents water from splashing out over the outer tub.



Outer tub

The outer tub holds the water and is mounted to the three legs of the leg and dome assembly.



Leg and dome assembly

The leg and dome assembly rests on the snubber and is held down and centered by six springs.



The leg and dome assembly supports the outer tub, transmission and drive motor.

Snubber

The snubber is located between the leg and dome assembly and the base.

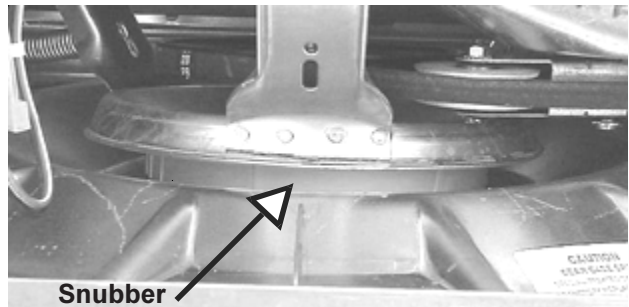

The snubber allows the leg and dome assembly to move while the base remains stationary.

Base

The base is made of heavy metal that is embossed for strength.



The base supports the complete weight of the washer, clothes and water.

SECTION E - ELECTRICAL OPERATION

When power is applied to the washer, L1 is connected to terminal 5 of the option switch and terminal T1 of the timer (the line switch).

Option switch circuits (some models)

If the option switch is set to the **OFF** position, the contacts between terminals 5 and 2, and 5 and 4 are open.

If the option switch is set to **Extra Rinse**, the contacts between terminals 5 and 4 are closed connecting L1 to terminal T13L of the timer. Terminal T13L is closed to terminal T14L of the timer during the off position between **Regular Wash** and **Extra Rinse**. This allows the timer to advance between **Regular Wash** and **Extra Rinse** without being reset.

If the option switch is set to **Power Scrub**, the contacts between terminals 5 and 2 are closed connecting L1 to terminal T16L of the timer. Terminal T16L is closed to timer terminal T14L during the off position between **Prewash** and **Regular Wash**. This allows the timer to advance between **Prewash** and **Regular Wash** without being reset.

If the option switch is set to **Power Scrub/Extra Rinse**, the contacts between terminals 5 and 2 and terminals 5 and 4 are closed connecting L1 to terminals T13L and T16L of the timer. This allows the timer to be started at **Prewash** and run through **Extra Rinse** without being reset.

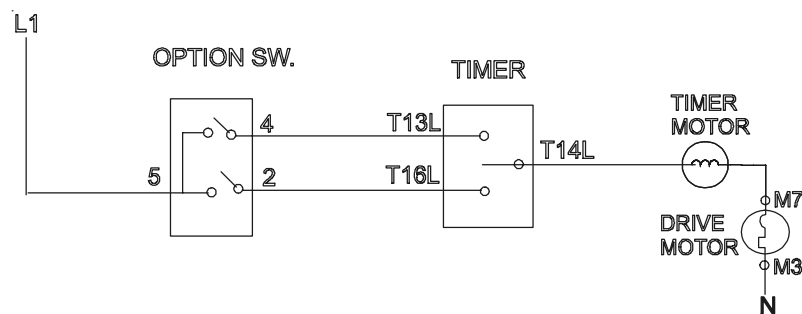

The other contacts in the option switch, 1 to 3 and 1 to 9, are used to control the end of cycle signal after **Prewash** and **Regular Wash**. When the option switch is set to **OFF**, both sets of contacts are closed and the end of cycle signal will sound after **Prewash** and **Regular Wash**.

When the option switch is set to **Power Scrub**, contacts 1 to 3 are closed. The end of cycle signal will not sound at the end of **Prewash** but will sound at the end of **Regular Wash**.

When the option switch is set to **Extra Rinse**, contacts 1 to 9 are closed. The end of cycle signal will not sound at the end of **Regular Wash** but will sound at the end of **Prewash**.

When the option switch is set to **Power Scrub/Extra Rinse**, both sets of contacts are open. The end of cycle signal will not sound at the end of **Prewash** or **Regular Wash**.

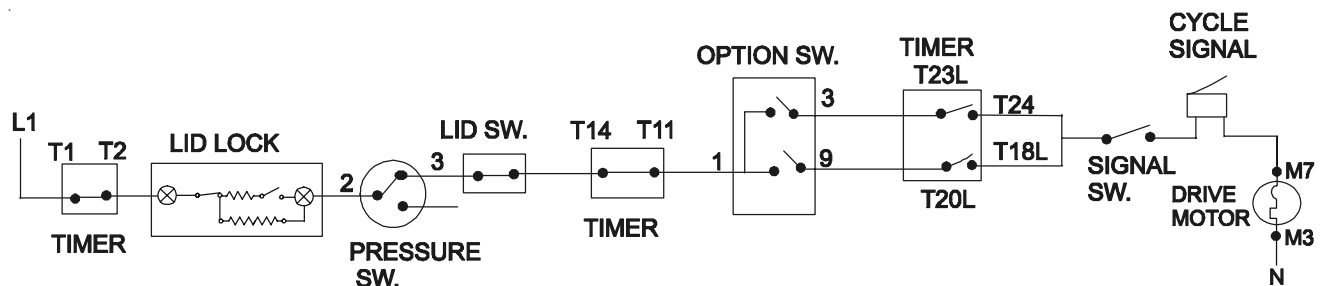

Line switch circuit

The line switch, formed by the contacts between terminals T1 and T2 of the timer, controls power to the washer. The contacts of the line switch are controlled by pulling the timer knob out to close and pushing the timer knob in to open.

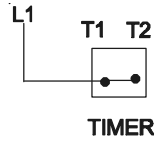

Fill circuit

At the start of the **Wash Cycle**, power passes through terminals T1 and T2 (the line switch) of the timer to terminal T16 of the timer. During the **Fill Cycle**, T16 is connected to terminal T17 of the timer. Terminal T17 is connected internally in the timer to terminal T10 of the timer. Terminal T10 is connected to terminal 2 of the pressure switch. When the tub does not have water in it, terminal 2 of the pressure switch is closed to terminal 1 of the pressure switch. From terminal 1 of the pressure switch, power is applied to terminal T23 of the timer. Terminal T23 is closed to terminal T22 of the timer. Terminal T22 provides two outputs, one to terminal FF of the temp switch and the other to terminal F of the temp switch through terminal T19 of the timer.

During the wash cycle when temp switch is set to:

- Hot / Cold** Contacts F to H of the temp switch are closed and power is applied to the hot solenoid.
- Warm / Cold** Contacts F to H and FF to C of the temp switch are closed and power is applied to both the hot and cold solenoids.
- Cold / Cold** Contacts FF to C of the temp switch are closed and power is applied to the cold solenoid.
- Warm / Warm** Contacts FF to H and FF to C of the temp switch are closed and power is applied to both the hot and cold solenoids.
- Reg Cold / Cold** Contacts FF to C and F to D of the temp switch are closed, FF to C applies power to the cold solenoid and F to D applies power to terminal 5 of the automatic temperature control. The hot solenoid is then cycled as needed by power from terminal 4 of the automatic temperature control to raise the incoming water temperature to around 70°F.
- Reg Warm / Cold** Contacts F to H and F to D of the temp switch are closed, F to H applies power to the hot solenoid and F to D applies power to terminal 5 of the automatic temperature control. The cold solenoid is then cycled, as needed, by power from terminal 6 of the automatic temperature control to lower the incoming water temperature to around 90°F.
- Reg Warm / Warm** Contacts FF to H and F to D of the temp switch are closed, FF to H applies power to the hot solenoid and F to D applies power to terminal 5 of the automatic temperature control. The cold solenoid is then cycled, as needed, by power from terminal 6 of the automatic temperature control to lower the incoming water temperature to around 90°F.

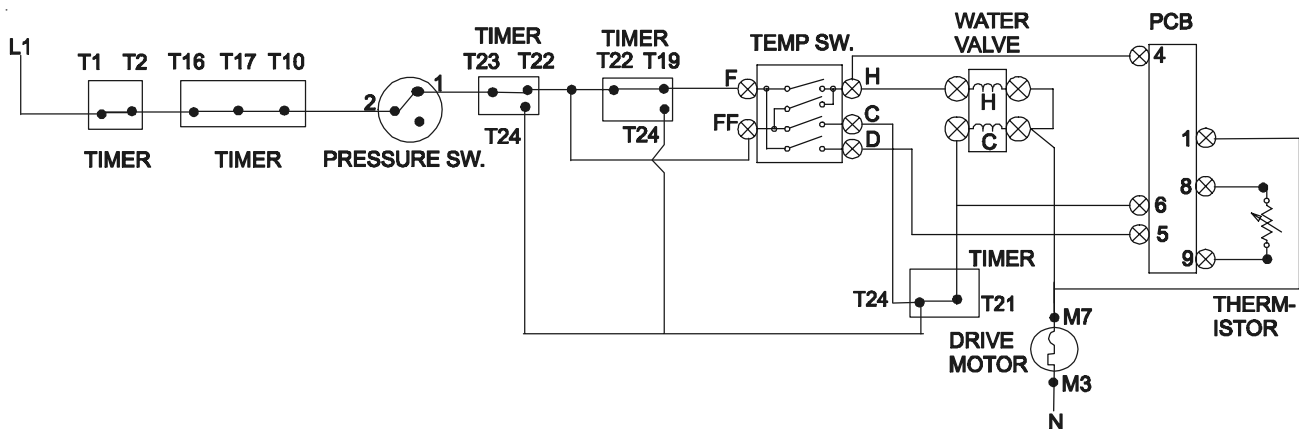

Spray rinse during the first pump cycle with the temp switch set to:

All settings other than Warm / Warm Timer contact T23 swings from T22 to T24. Terminal T24 provides power through T21 to the cold water solenoid.

Warm / Warm Timer contact T23 swings from T22 to T24. Terminal T24 provides power through T21 to the cold water solenoid and power to terminal C of the temp switch. With contacts FF to H and FF to C of the temp switch closed, power is applied to the hot solenoid giving a warm spray rinse.

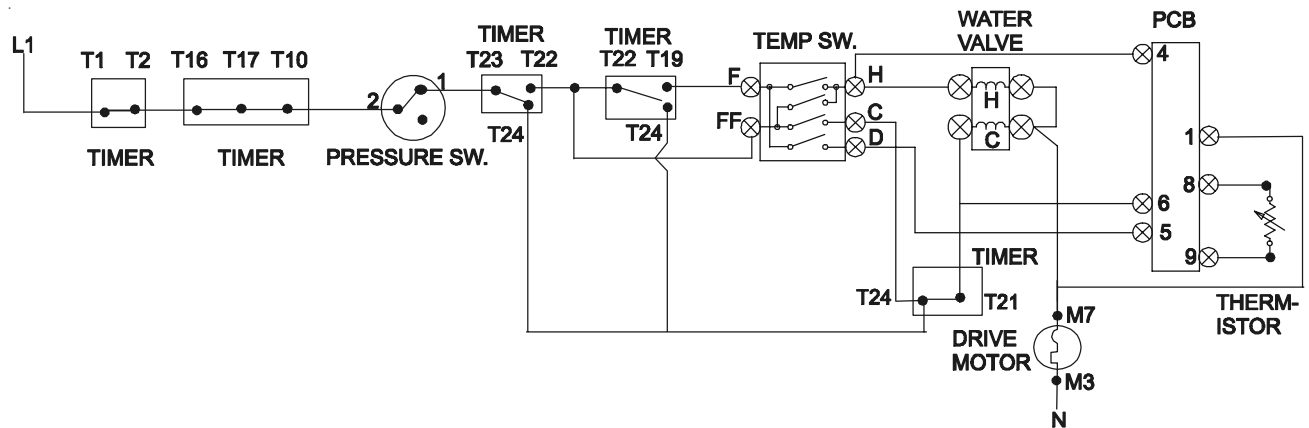

During the rinse cycle with temp switch set to:

All settings other than Warm / Warm Timer contact T23 swings from T24 to T22 and timer contact T22 is closed to T24. Terminal T24 provides power through T21 to the cold water solenoid.

Warm / Warm Timer contact T23 swings from T24 to T22 and timer contact T22 is closed to T24. Terminal T24 provides power through T21 to the cold water solenoid and power to terminal C of the temp switch. With contacts FF to H and FF to C of the temp switch closed, power is applied to the hot solenoid giving a warm rinse.

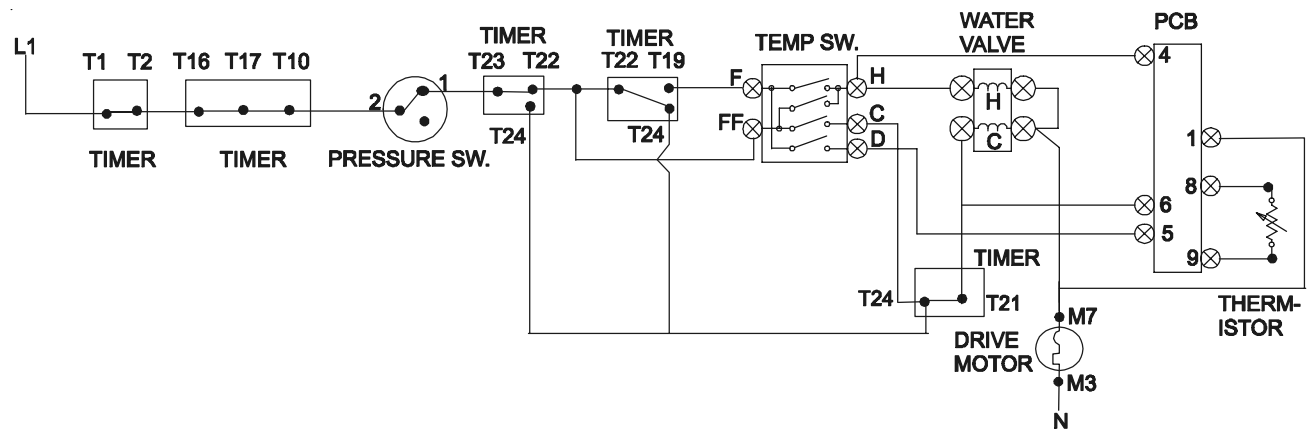

Timer Motor Circuit

When the line switch is closed there are two possible paths for current flow, through contacts T16 and T17 of the timer or through the contacts of the lid lock. The contacts in the timer are in parallel with the contacts of the lid lock switch and the bimetal heater. The lid lock switch circuit and the lid lock heater circuit have resistance. When the washer is in the wash cycle contacts T16 to T17 of the timer are closed. Current follows the path of least resistance through contacts T16 to T17 to terminal TM of the timer. Terminal TM supplies power to the winding of the timer motor and the circuit is completed through the thermal fuse in the drive motor to neutral. When the washer is in the spin cycle, the contacts between terminals T16 and T17 of the timer are open and the current flows to the timer motor through the lid lock.

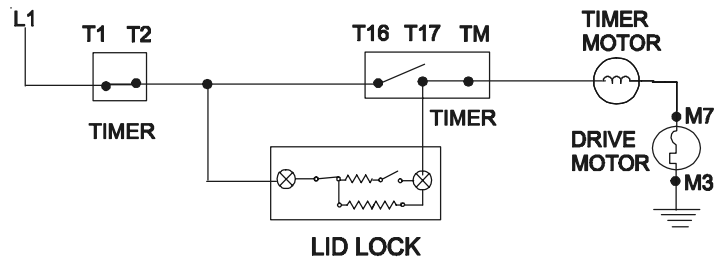

Drain Pump Motor Circuit

During pump out, current flows through the line switch, the lid lock, contacts T17 and T18 of the timer, the winding of the pump motor and the thermal fuse of the main motor to neutral.

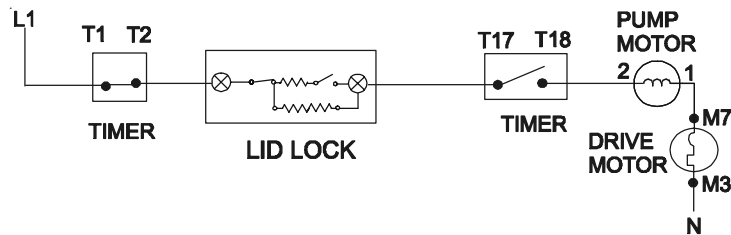

Drive motor circuit

Motor in agitation cycles

Current flows from L1 through contact T1 to T2 of the timer to terminal T16 of the timer. T16 is closed to terminal T17 of the timer and T17 is connected internally in the timer to terminal T10 of the timer. T10 supplies power to terminal 2 of the pressure switch. When the water fill has satisfied the pressure switch, terminal 2 of the pressure switch is closed to terminal 3 of the pressure switch. Terminal 3 of the pressure switch is connected to one side of the lid switch, when the lid is down the lid switch is closed supplying power to terminal T14 of the timer. T14 is closed to terminal T12 of the timer that supplies power to terminal M2 of the drive motor. M2 is connected in the motor to the run centrifugal switch. When the motor is not running, the output terminal of the run centrifugal switch is connected to one end of the high speed run winding and to terminal M6 of the motor. The other end of the high speed run winding is connected internally in the motor through the thermal fuse terminal to terminal M3 of the motor. Terminal M3 is connected to neutral allowing current flow through the high speed run winding. Terminal M6 of the motor is connected to terminals T7 and T4 of the timer. During agitation T7 is closed to timer terminal T8 which is connected to one end of the start capacitor. The other end of the start capacitor is connected to motor terminal M5. Terminal M5 is connected to the start winding through the start winding centrifugal switch. The other end of the start winding is connected to terminal M1 of the motor. Terminal M1 of the motor is connected through timer contacts T9 to T5 to terminal M7 of the motor. Terminal M7 of the motor is connected through the motor thermal fuse to terminal M3 of the motor which is connected to neutral. Current now flows through the start capacitor (that changes the phase of the current) through the start winding to neutral and the motor starts to turn.

Agitation cycle - motor not running

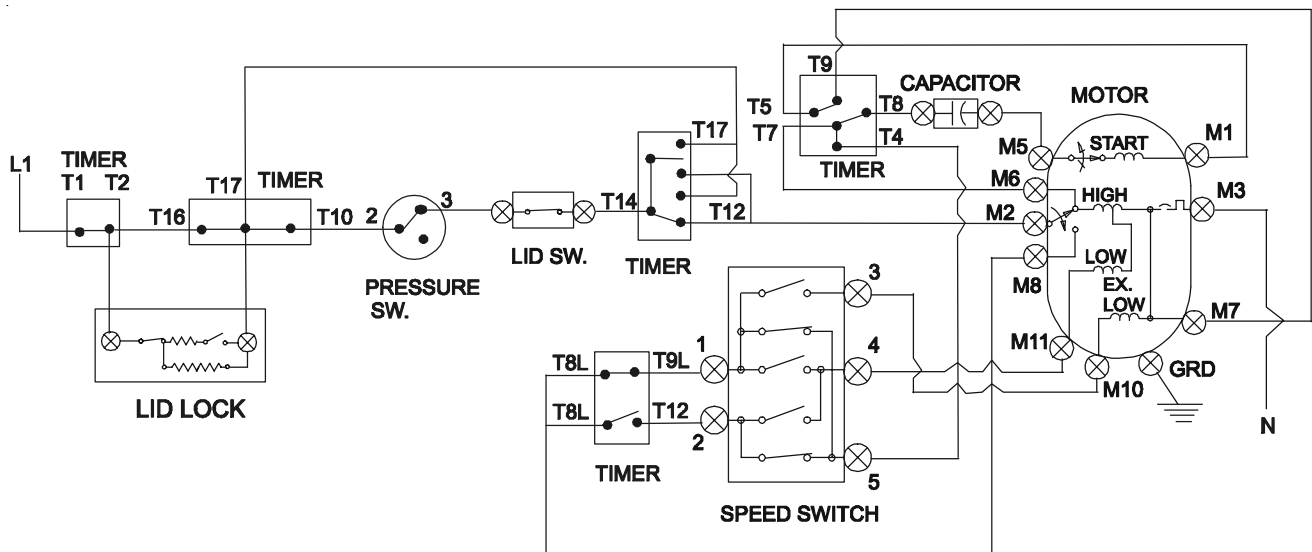

When the motor reaches approximately 80 percent of its normal run speed, the start winding centrifugal switch opens removing power from the start winding. The run winding centrifugal switch changes from motor terminal M6 to motor terminal M8. M8 is connected to terminal T8L of the timer. During agitation, T8L is closed to terminal T9L of the timer that supplies power to Terminal 1 of the speed switch. If the speed switch is set to **Normal**, terminal 1 of the speed switch is connected to terminal 5 of the speed switch that supplies power to terminal T4 of the timer. Terminal T4 of the timer is connected to terminal M6 that supplies power to the high speed run winding. If the speed switch is set to **Gentle**, terminal 1 of the speed switch is connected to terminal 4 of the speed switch that supply power to terminal M11 of the motor. Terminal M11 supplies power to the low speed run winding. If the speed switch is set to **Extra Gentle**, terminal 1 of the speed switch is connected to terminal 3 of the speed switch that supplies power to terminal M10 of the motor. Terminal M10 supplies power to the extra low speed run winding.

Agitation cycle - motor running

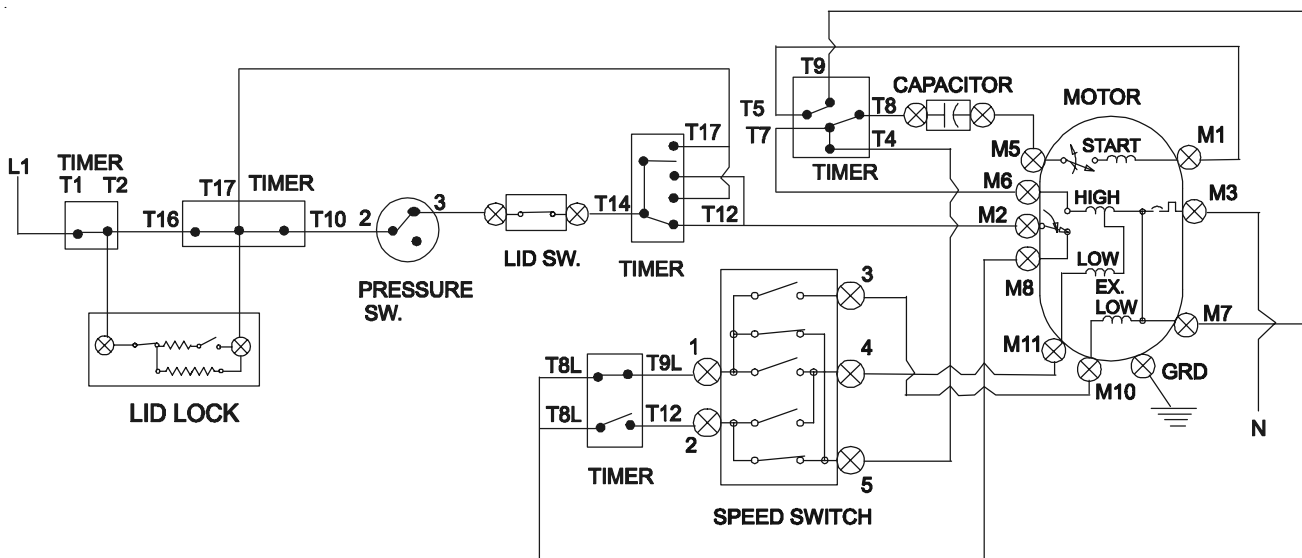

Note: The drive motor always starts at high speed, then changes to the speed switch setting.

Motor in spin cycle

Current flows from L1 through contact T1 to T2 of the timer to the lid lock. When the lid is closed, the lid lock arm closes a set of contacts inside the lid lock applying power through the lid lock bimetal element. As current flows through the bimetal element in the lid lock, it forces the locking arm to engage the lid strike. This provides power to terminal T17 of the timer. Terminal T17 is closed to terminal T14 of the timer. T14 is closed to terminal T12 of the timer that supplies power to terminal M2 of the drive motor. M2 is connected in the motor to the run centrifugal switch. When the motor is not running, the output terminal of the run centrifugal switch is connected to one end of the high speed run winding and to terminal M6 of the motor. The other end of the high speed run winding is connected internally in the motor through the thermal fuse to terminal M3 of the motor. Terminal M3 is connected to neutral allowing current flow through the high speed run winding. Terminal M6 of the motor is connected to terminals T7 and T4 of the timer. During spin, T7 is closed to terminal T5 of the timer, which is connected to terminal M1 of the motor. Terminal M1 is connected to one end of the start winding. The other end of the start winding is connected to motor terminal M5 through the start winding centrifugal switch. Terminal M5 of the motor is connected to one end of the start capacitor. The other end of the start capacitor is connected to terminal T8 of the timer. T8 is closed to terminal T9 of the timer which is connected to terminal M7 of the motor. Terminal M7 of the motor is connected through the motor thermal fuse to terminal M3 of the motor that is connected to neutral. Current now flows through the start winding, the start capacitor (that changes the phase of the current) to neutral and the motor starts to turn.

Spin cycle - motor not running

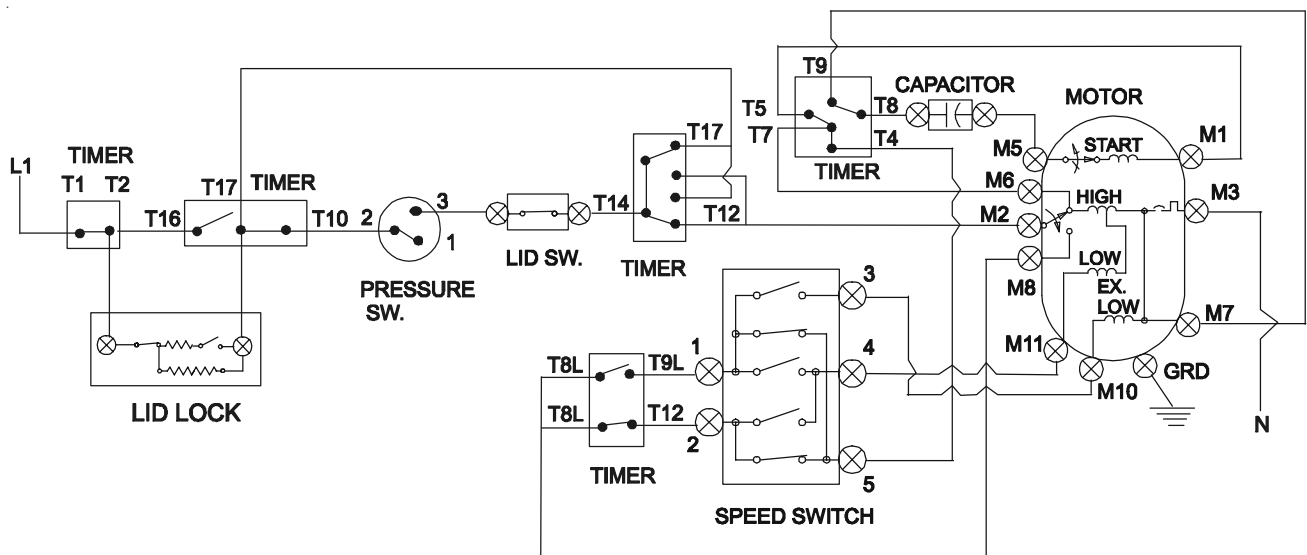

Note: The drive motor always starts at high speed then changes to the speed switch setting.

When the motor reaches approximately 80 percent of its normal run speed the start winding centrifugal switch opens, removing power from the start winding. The run winding centrifugal switch changes from motor terminal M6 to motor terminal M8. M8 is connected to terminal T8L of the timer. During spin, T8L is closed to terminal T12 of the timer that supplies power to terminal 2 of the speed switch. If the speed switch is set to **Normal/Fast** or **Gentle/Fast**, terminal 2 of the speed switch is connected to terminal 5 of the speed switch that supplies power to terminal T4 of the timer. Terminal T4 of the timer is connected to terminal M6 of the motor that supplies power to the high speed run winding. If the speed switch is set to **Gentle/Slow** or **Extra Gentle/ Slow**, terminal 2 of the speed switch is connected to terminal 4 of the speed switch that supplies power to terminal M11 of the motor. Terminal M11 supplies power to the low speed run winding.

Spin cycle - motor running

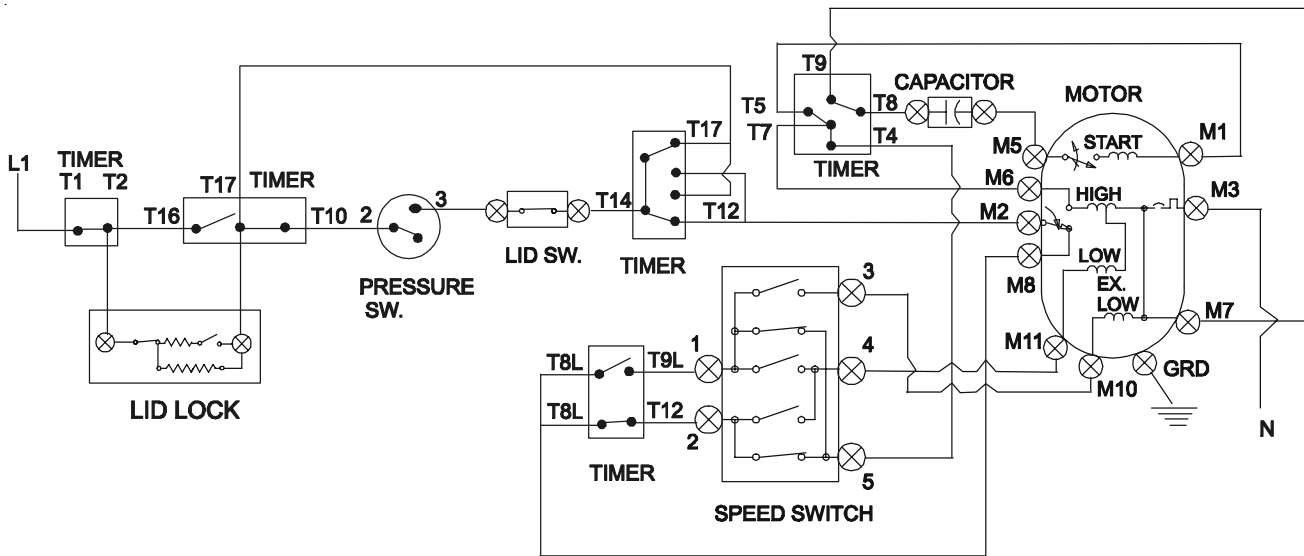

SECTION F - TROUBLESHOOTING FLOW CHARTS

NOTE: Always check the wiring and pin/plug connectors before replacing any component.

Washer completely inoperative.	Page 52
Timer does not advance.	Page 52
Washer does not drain.	Page 53
Drive motor operates in spin but not in agitation.	Page 53
Drive motor does not turn.	Page 54
Drive motor operates in agitation but not in spin.	Page 55
Slow water fill.	Page 55
Drive motor cycles off and on rapidly when the speed switch set to Normal .	Page 56
Drive motor cycles off and on rapidly when the speed switch set to Gentle .	Page 56
Drive motor cycles off and on rapidly when the speed switch set to ExGentle .	Page 57
Auto temp control does not control the wash water temperature within specification.	Page 57
Water fill does not turn off.	Page 58
Incorrect water level.	Page 58
Washer will not fill in any setting of the temperature selector switch.	Page 59
Washer will not fill in wash cycle, but will fill in rinse with the temp switch set to cold/cold.	Page 60
Washer will only fill with cold water in the wash cycle, with the temp switch set to warm/cold.	Page 60
Water temperature is too hot or too cold in the wash cycle with the temp sw. set to warm/warm.	Page 61
Washer will only fill with hot water in the wash cycle, with the temp switch set to warm/cold but does fill with cold water in the rinse cycle.	Page 61

Washer completely inoperative.

Note: Always check wiring to the components.

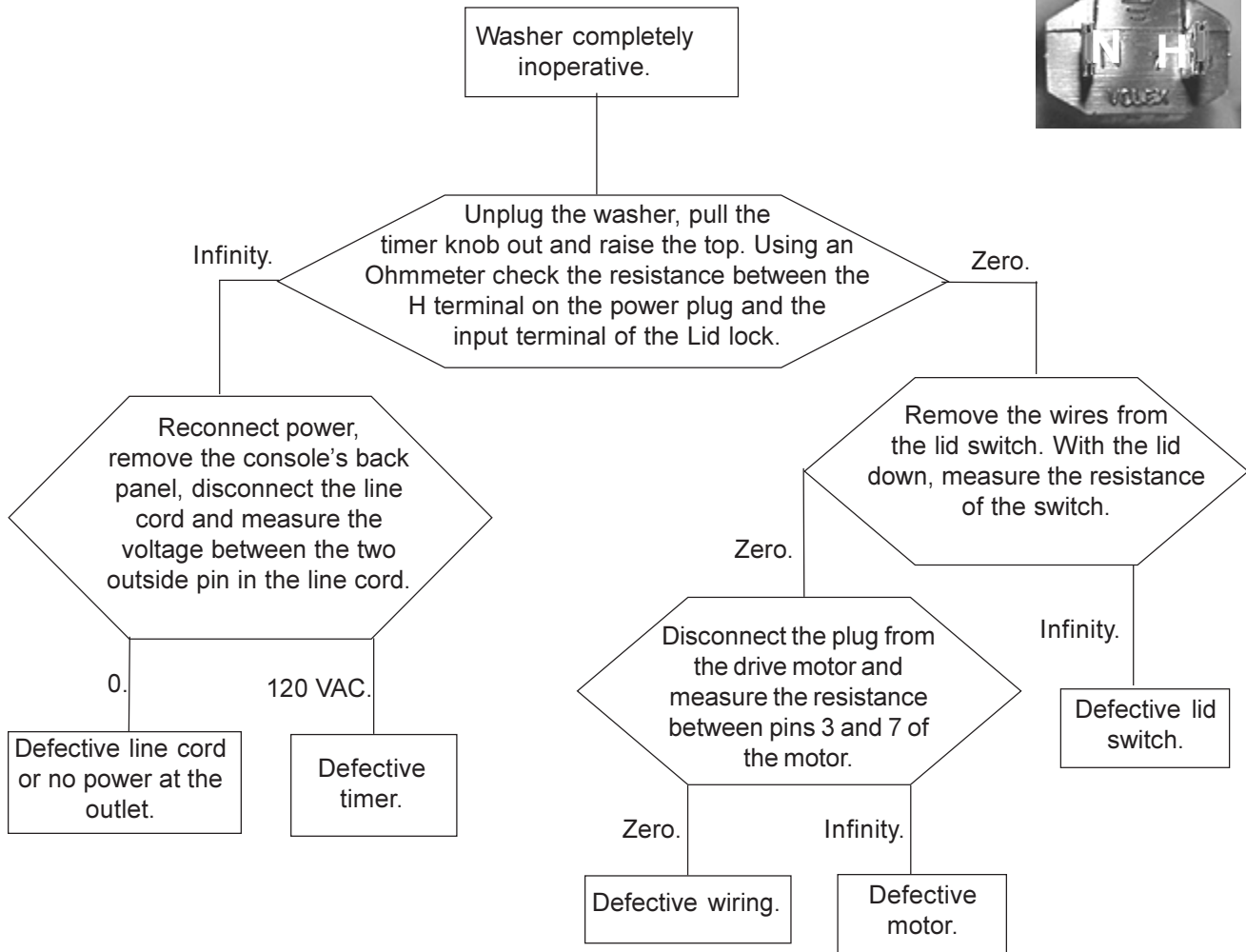

Timer does not advance.

Note: Always check wiring to the components.

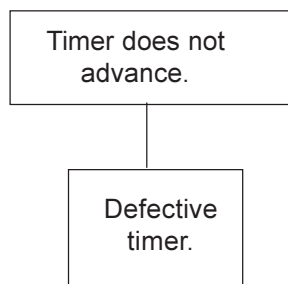

Washer does not drain.

Note: Always check wiring to the components.

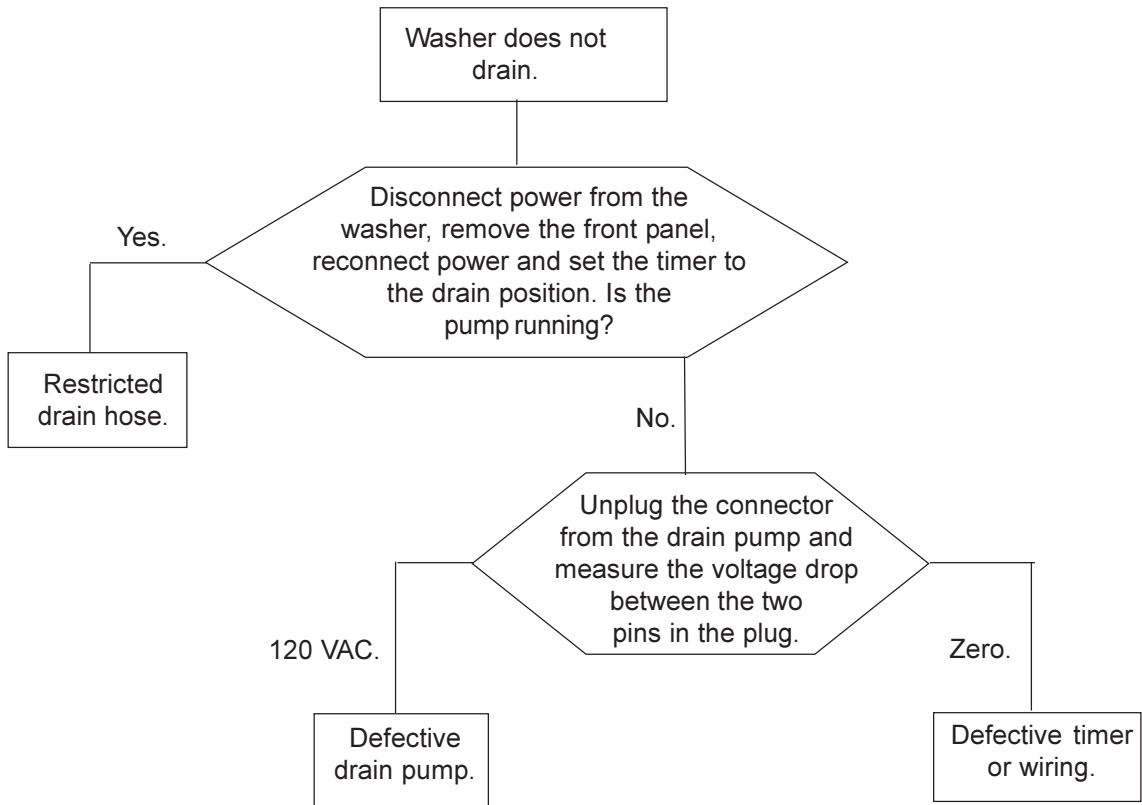

Drive motor operates in spin but not in agitation.

Note: Always check wiring to the components.

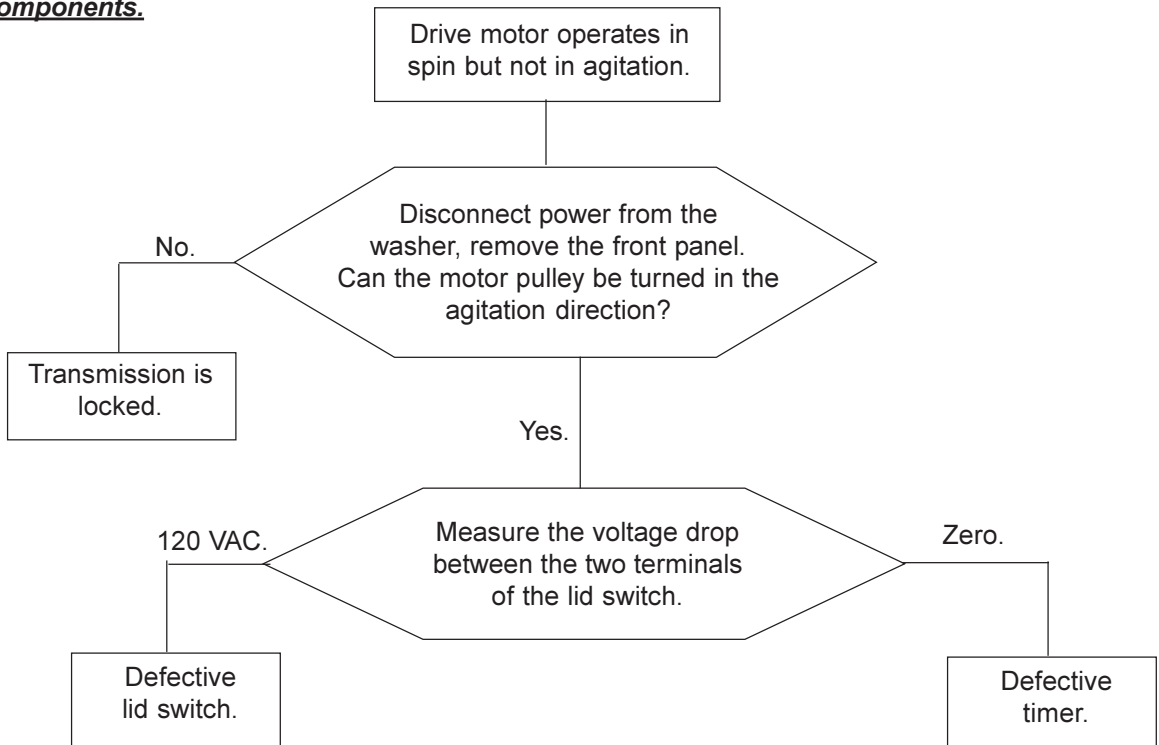

Drive motor does not turn.

Note: Always check wiring to the components.

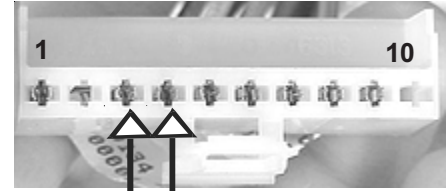
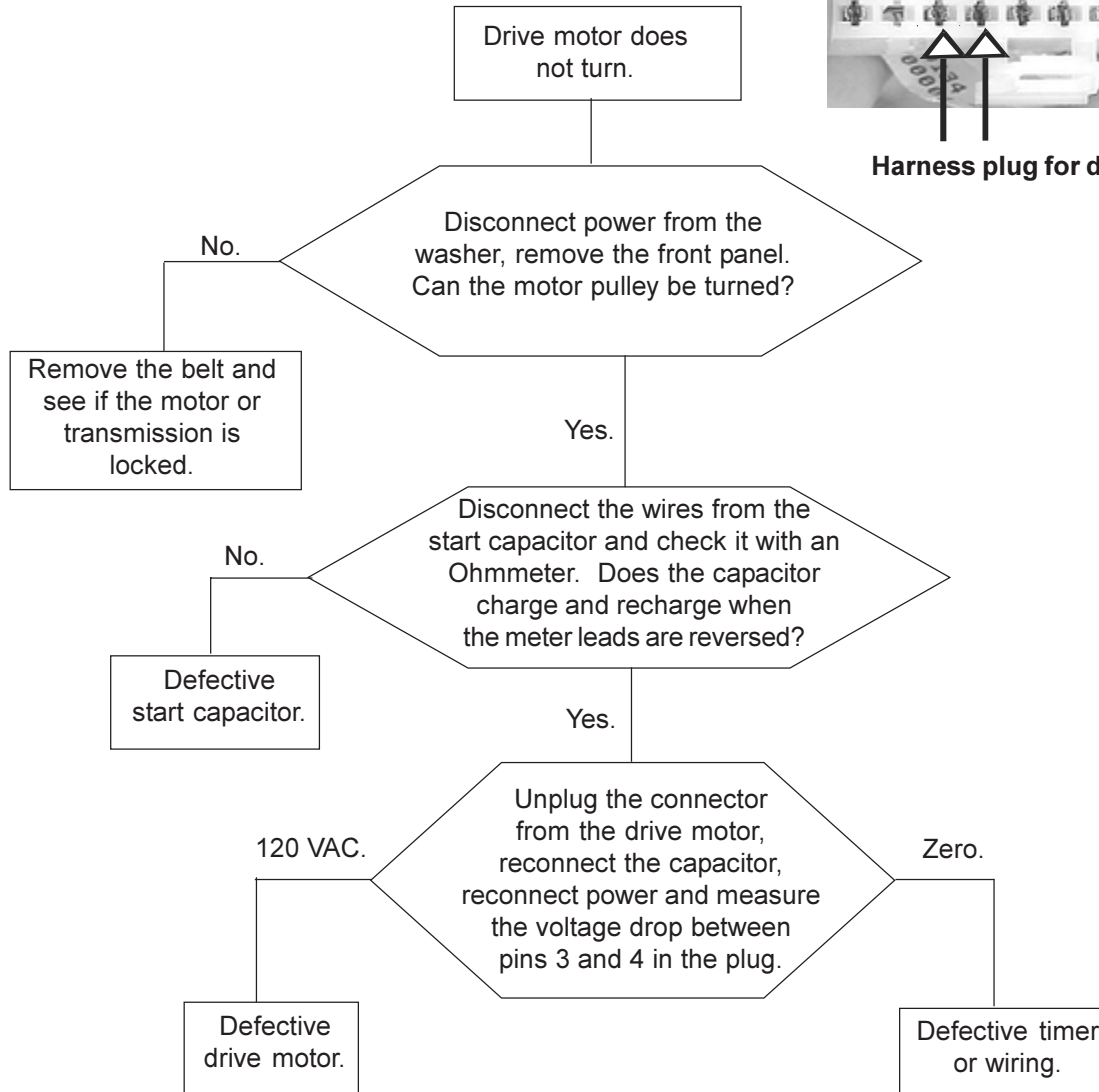

Harness plug for drive motor

Drive motor operates in agitation but not in spin.

Note: Always check wiring to the components.

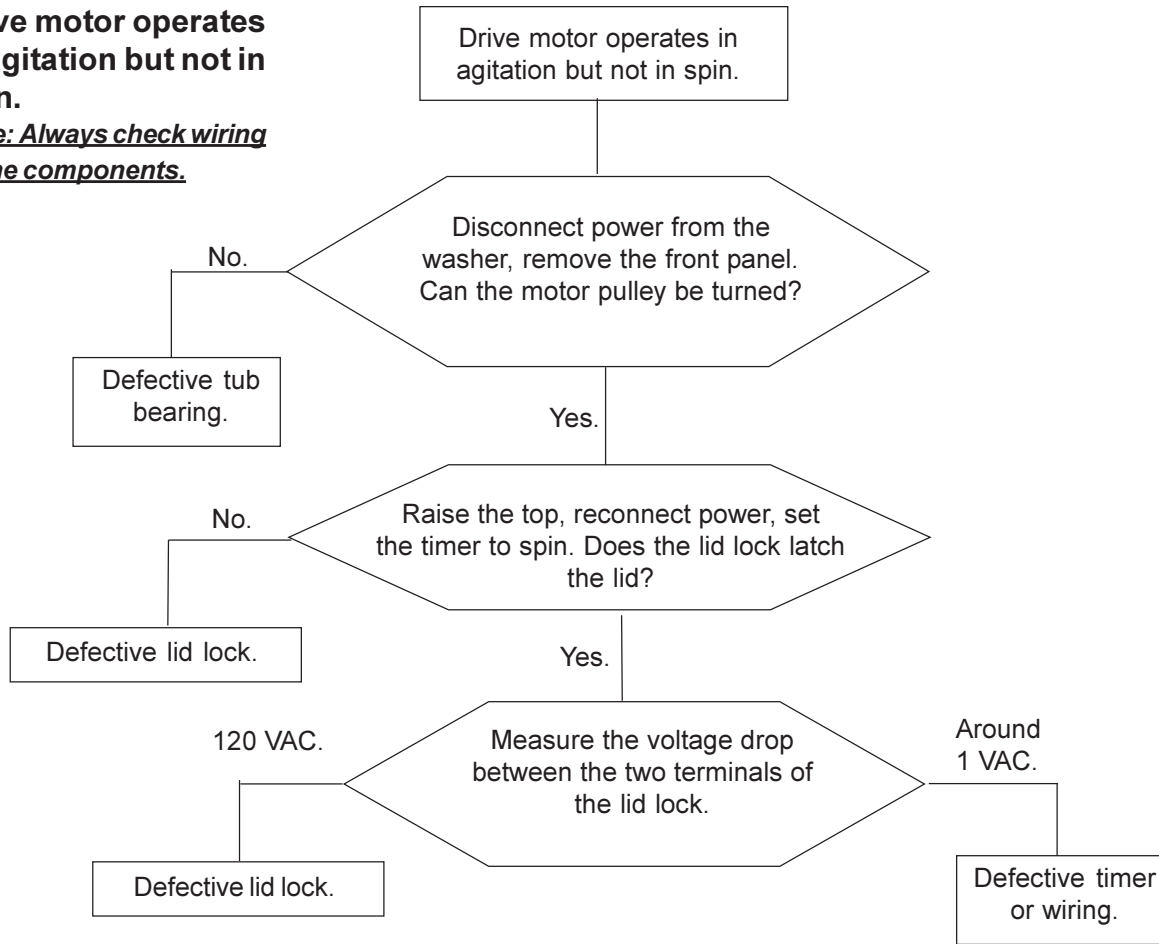

Slow water fill.

Note: Always check wiring to the components.

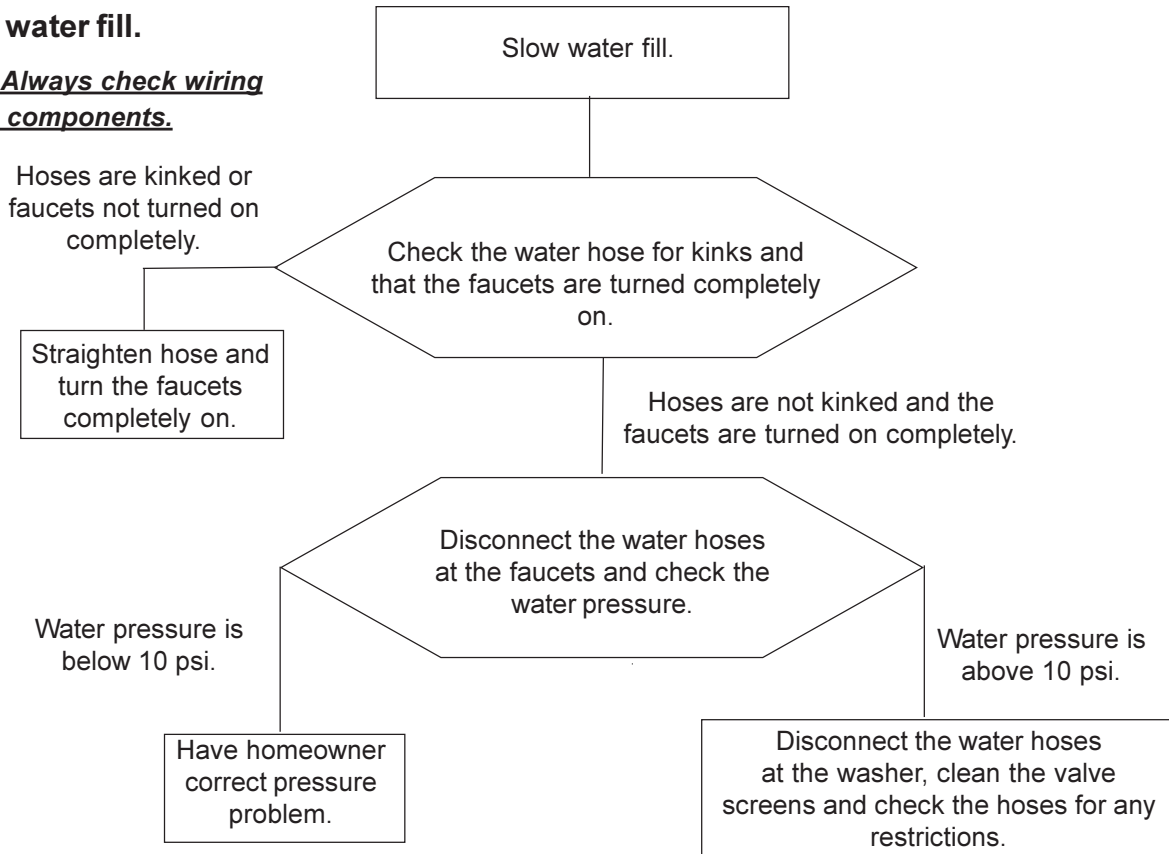

Drive motor cycles off and on rapidly when the speed switch is set to Normal.

Note: Always check wiring to the components.

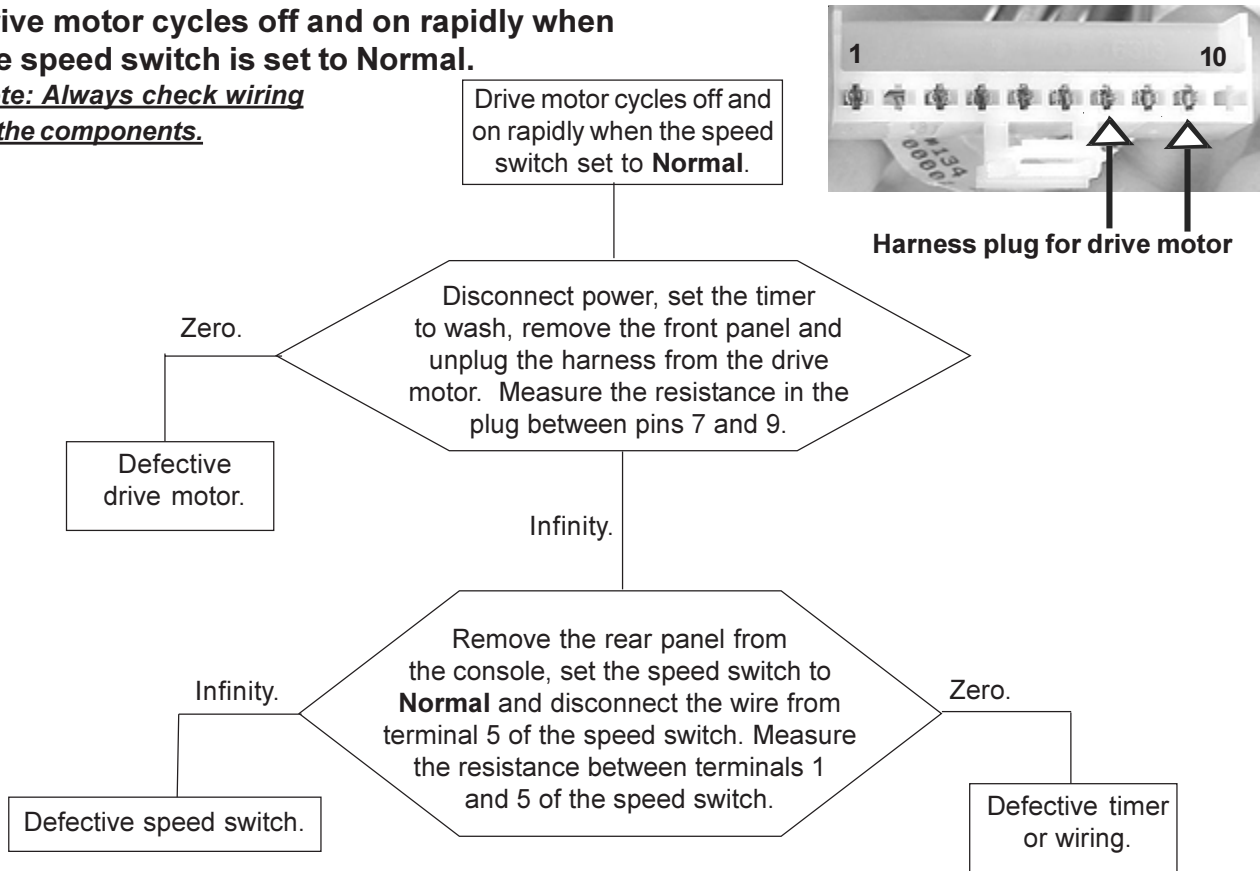

Drive motor cycles off and on rapidly when speed switch is set to Gentle.

Note: Always check wiring to the components.

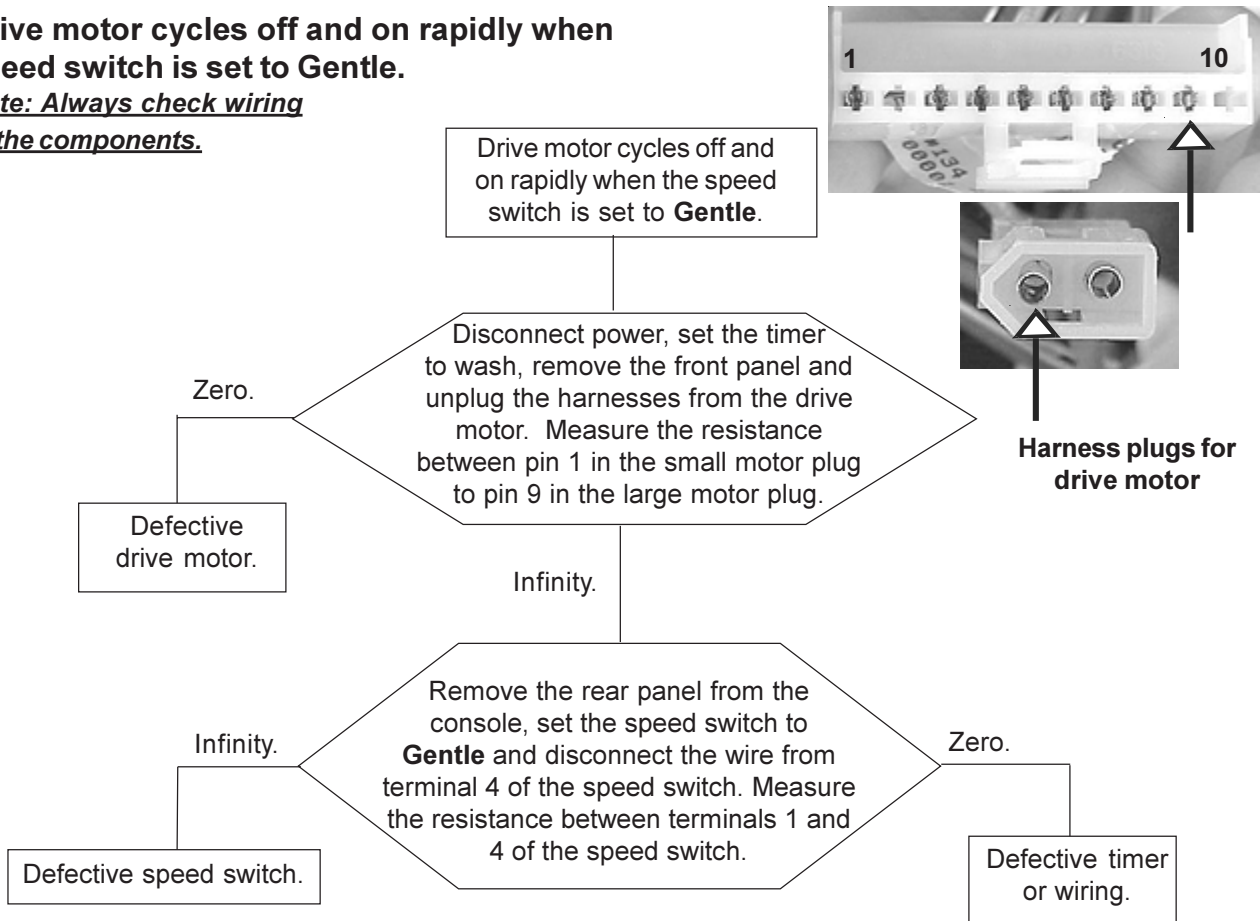

Drive motor cycles off and on rapidly when speed switch is set to ExGentle.

Note: Always check wiring to the components.

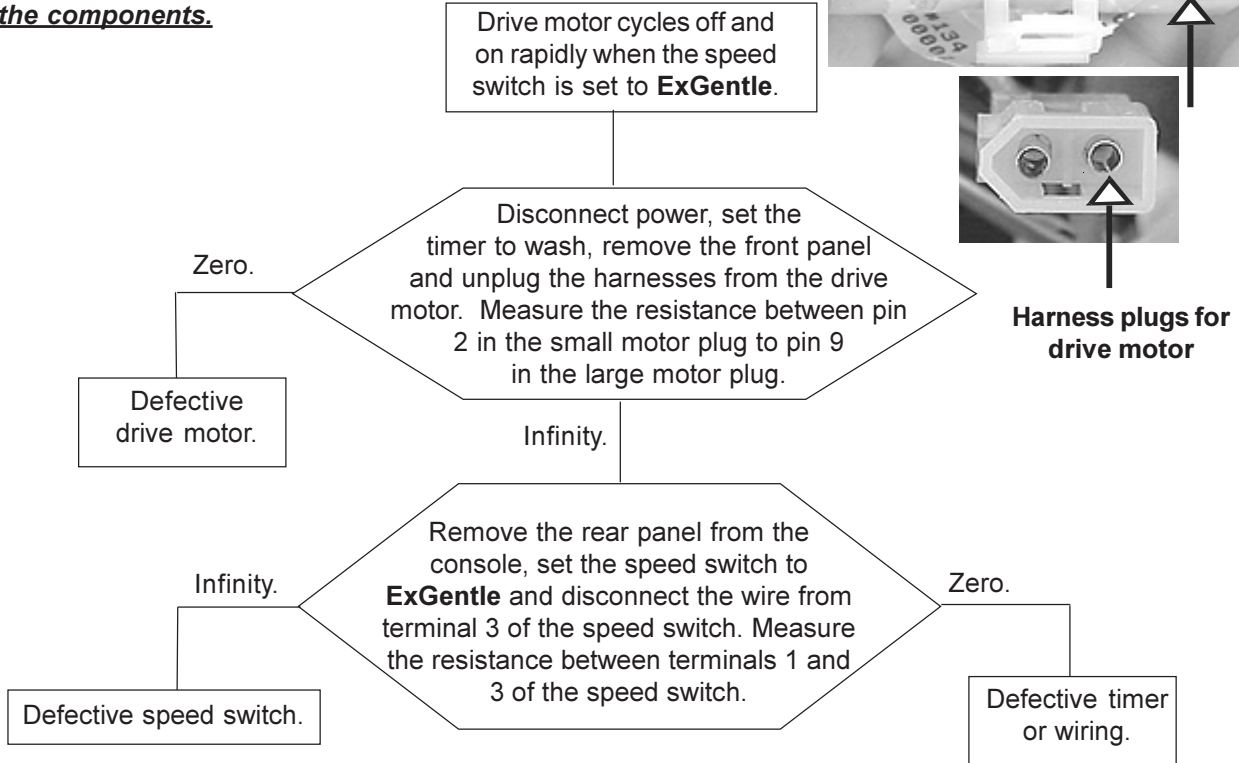

Auto Temp Control does not control the wash water temperature within specifications.

Note: Always check wiring to the components.

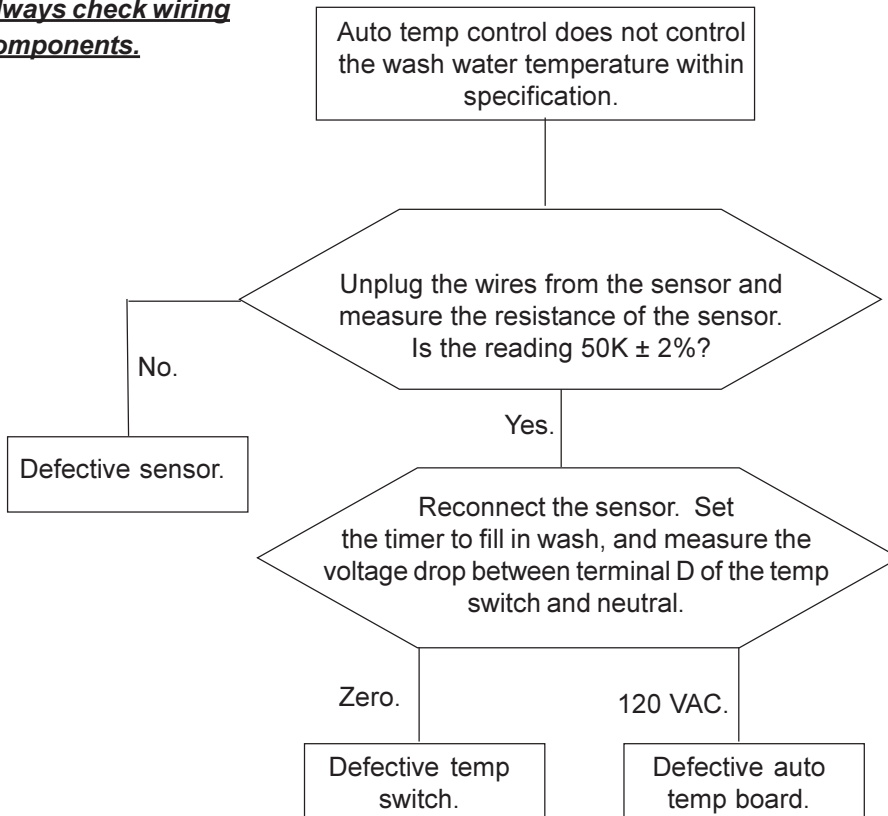

Water fill does not turn off.

Note: Always check wiring to the components.

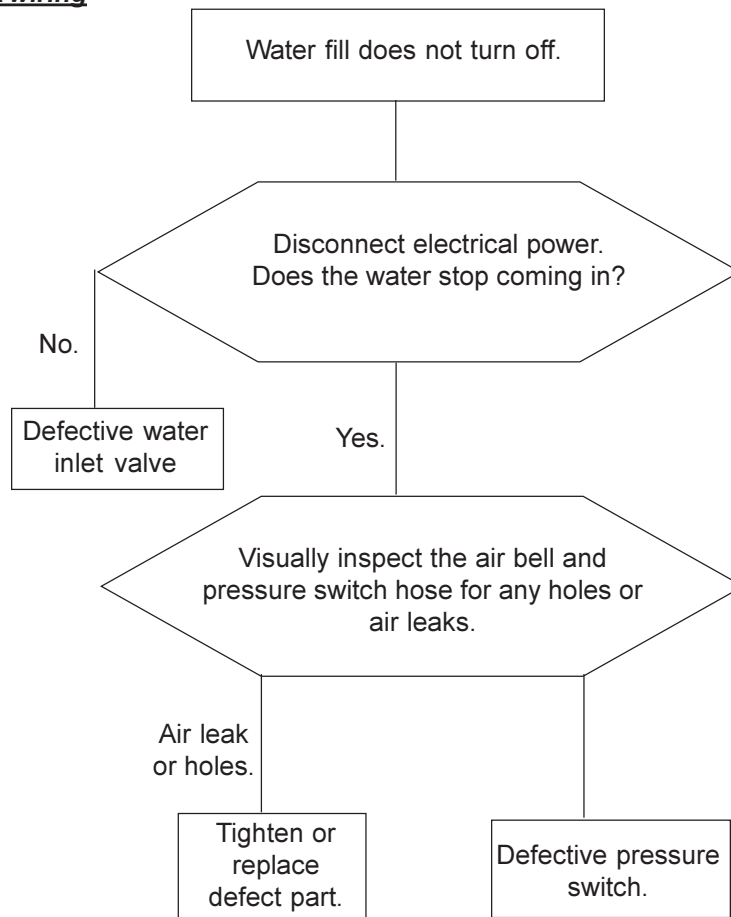

Incorrect water level.

Note: Always check wiring to the components.

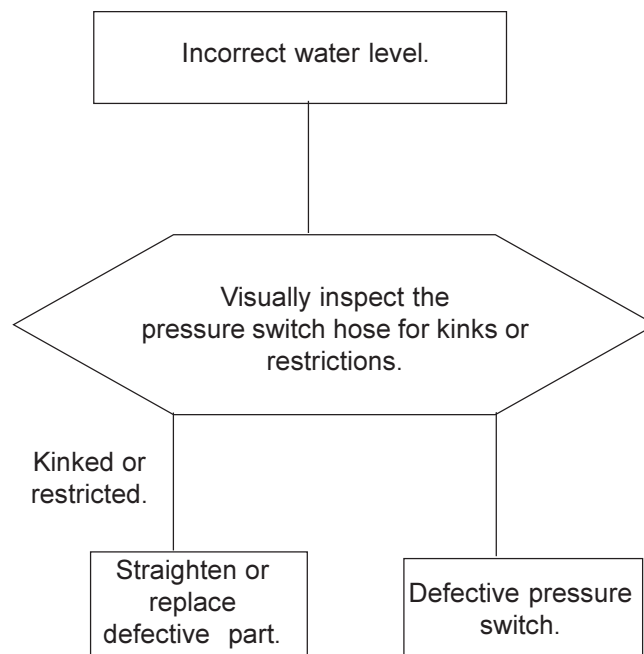

Washer will not fill in any setting of the temp switch.

Note: Always check wiring to the components.

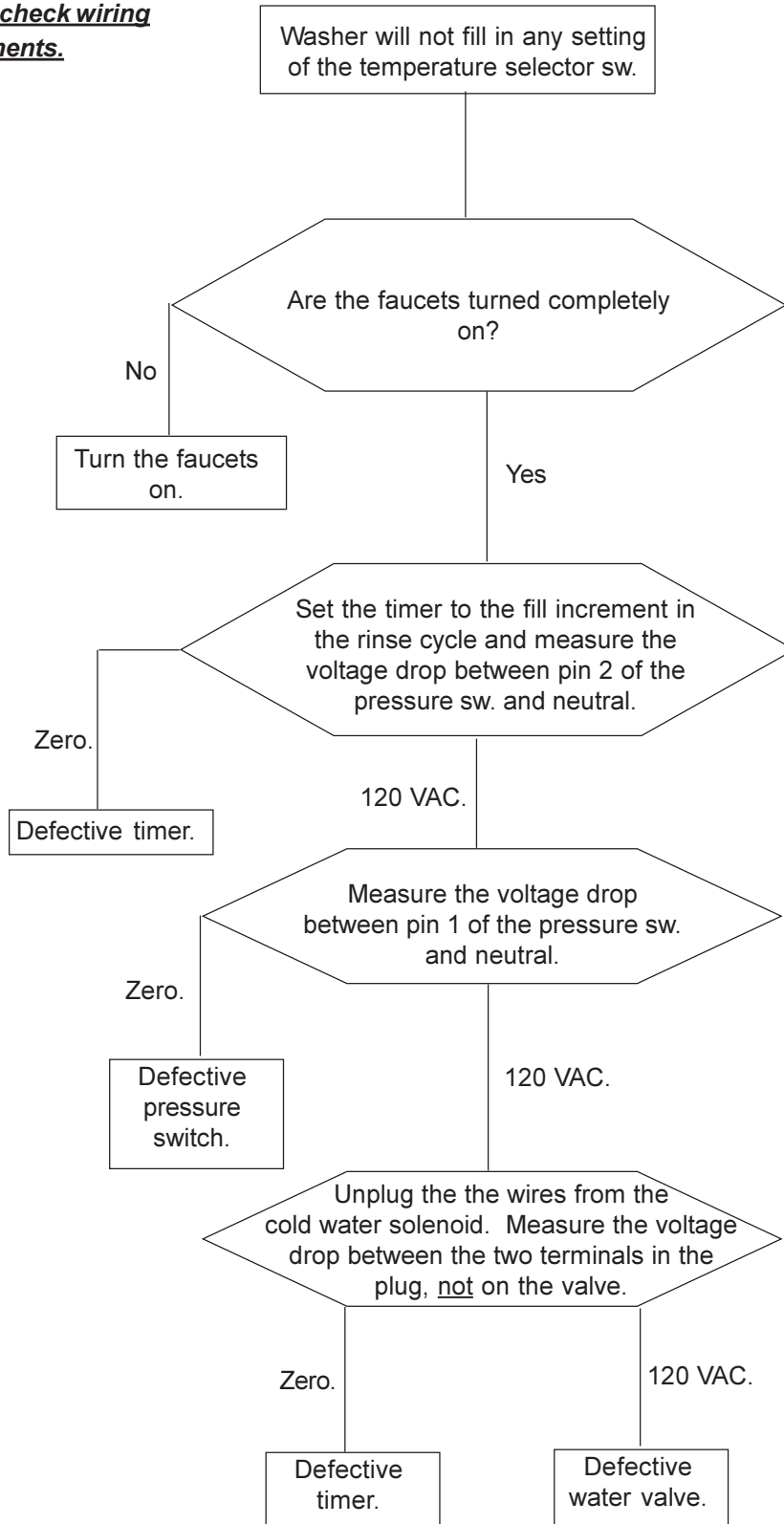

Washer will not fill in wash cycle, but will fill in rinse with the temp switch set to Cold/Cold.

Note: Always check wiring to the components.

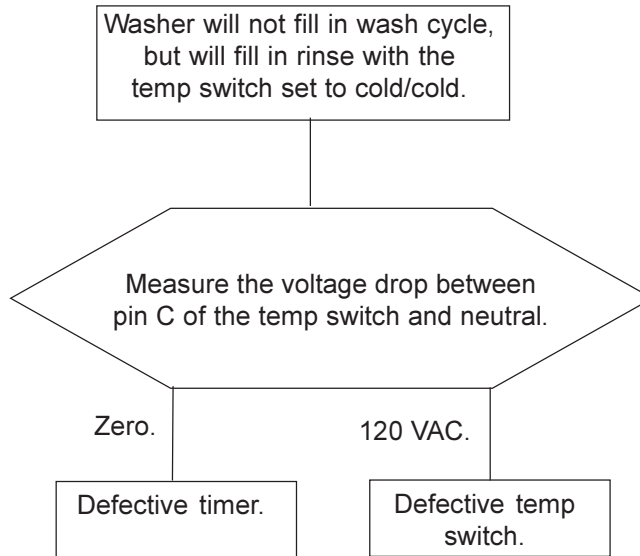

Washer will only fill with cold water in the wash cycle, with the temp switch set to Warm/Cold.

Note: Always check wiring to the components.

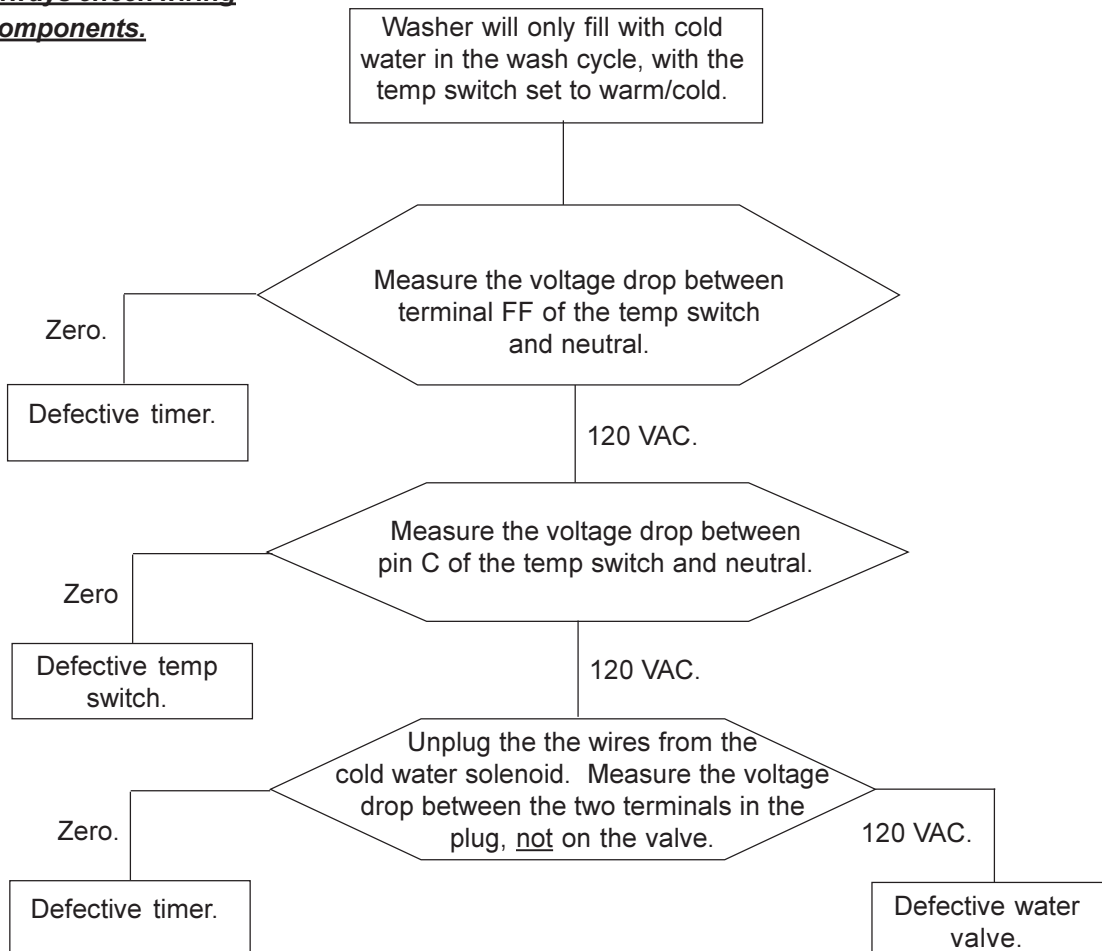

Water temperature is too hot or too cold in the wash cycle with the temp switch set to Warm/Warm.

Note: Always check wiring to the components.

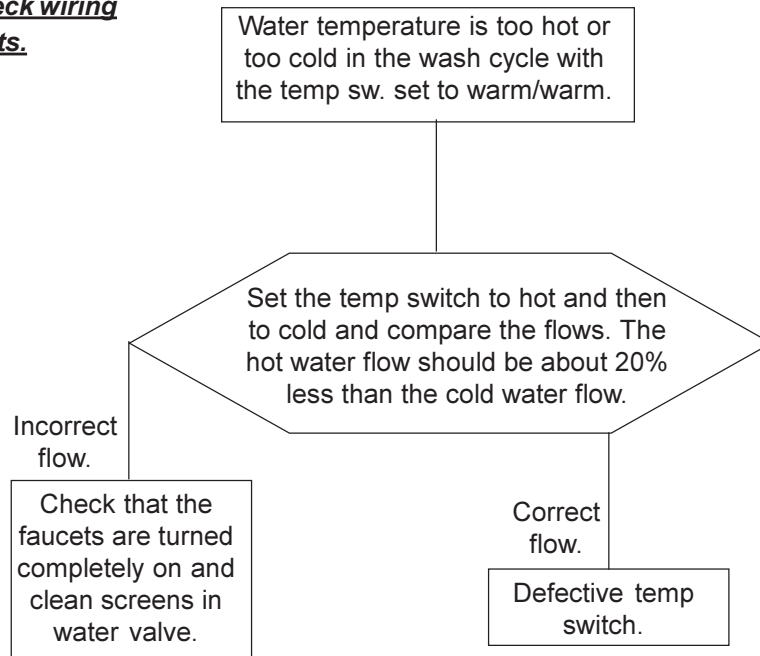

Washer will only fill with hot water in the wash cycle, with the temp switch set to Warm/Cold, but does fill with cold in the rinse cycle.

Note: Always check wiring to the components.

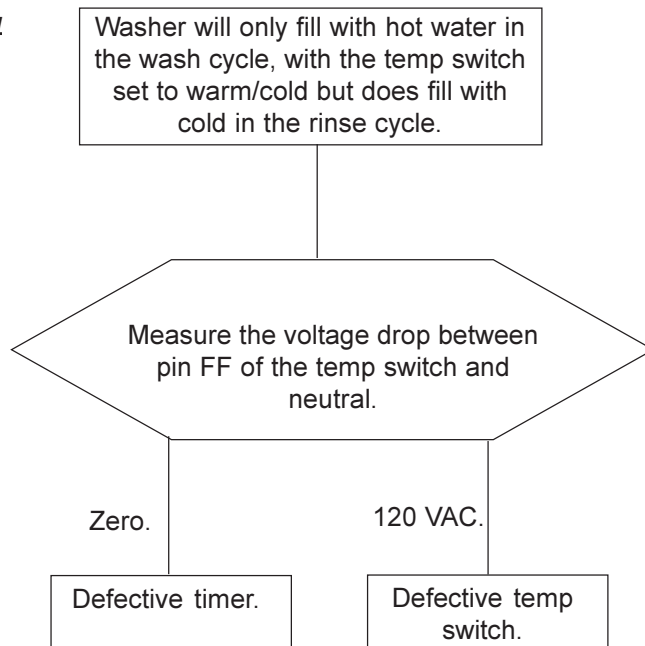

SECTION G - TEARDOWN

This section will describe how to remove components from a top load washer. Unless stated, the procedure will be the same on all top load washers. Unless stated, reverse the procedure to reinstall the component.

⚠ WARNING Always remove electrical power from the washer when working in an area where electrical power is present.

Removing the knobs:

Timer knob: (some models)

1. The timer knob is threaded to the shaft. To remove the timer knob push the knob in, to the off position, and turn the knob counter clockwise.

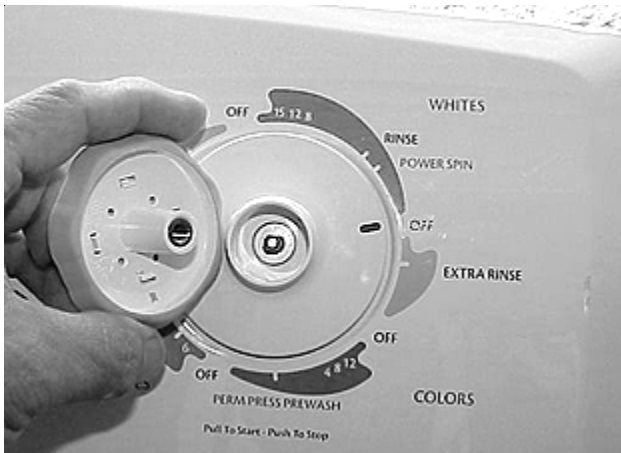

Timer knob: (some models)

1. The timer knob is held on the shaft by a locking rod that extends to the rear of the timer. To remove the knob, disconnect power, remove the rear panel of the console and using a small screwdriver pull the locking rod backward to release the knob.

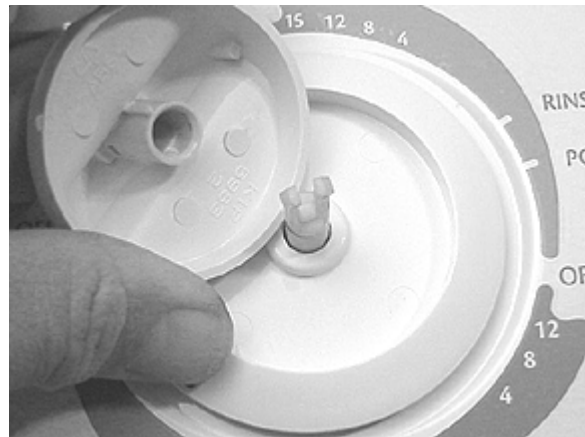
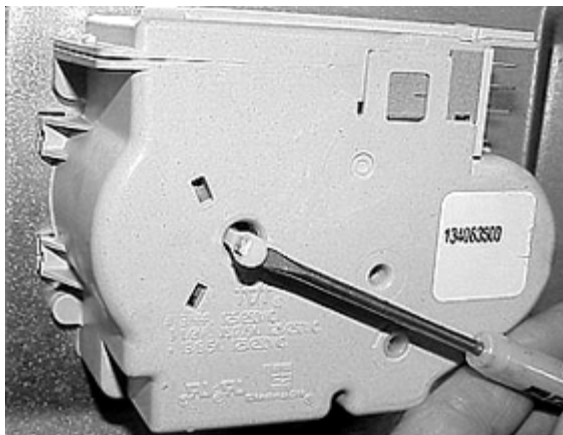

Timer skirt: (some models)

1. Remove the timer knob and the washer around the timer shaft between the knob and the skirt.

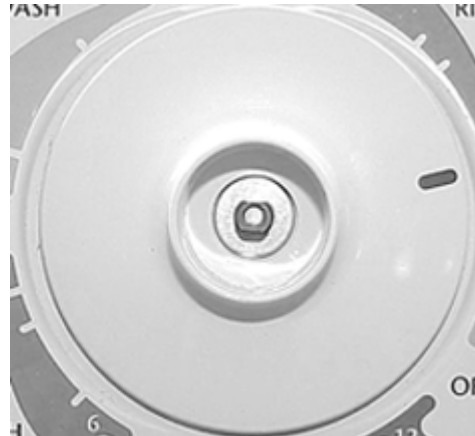

2. Pull the skirt straight off.

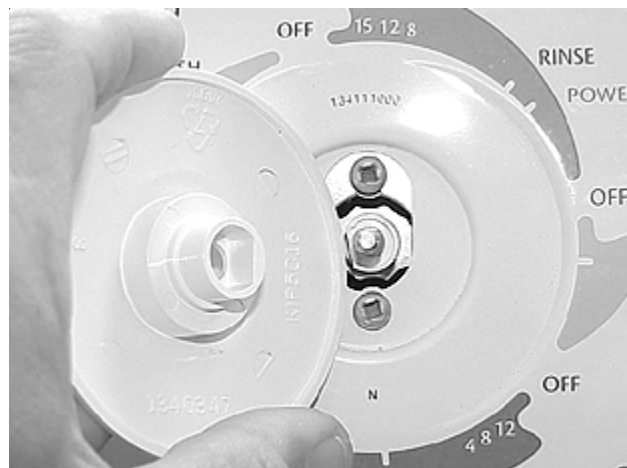

Timer skirt: (some models)

1. Remove the timer knob and pull the skirt straight off



All other knobs:

1. The shafts of the knobs are D shaped and pull straight off.

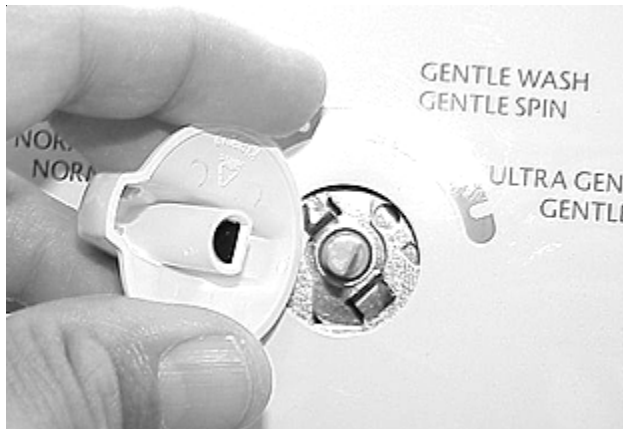

Raising the top:

1. The top is held in the rear by hinges and slots

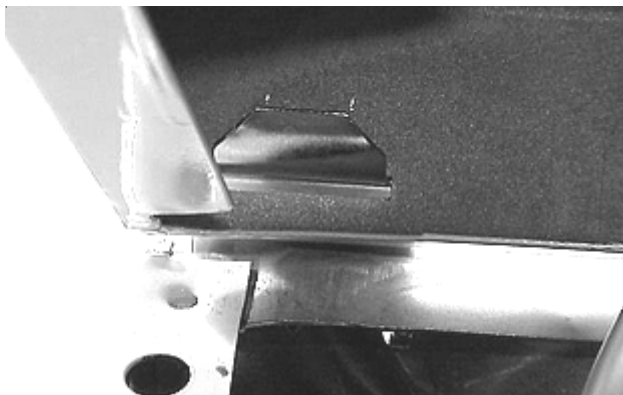

and in front by two spring loaded clips.

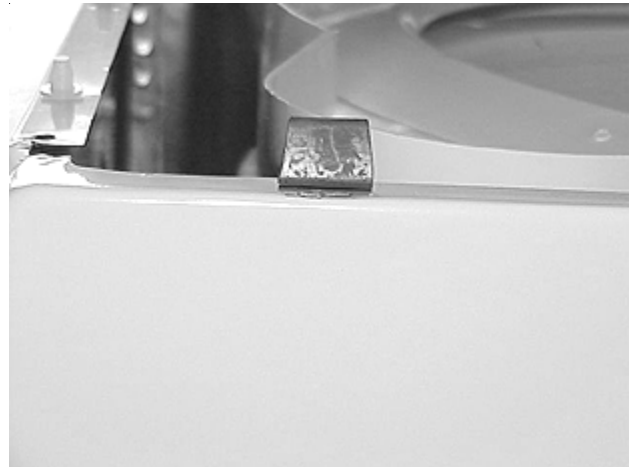

2. Insert a flat object, such as a putty knife, between top and front panel to release the clip and lift up on the top.



Removing the rear panel from console:

1. Disconnect the washer from electrical supply.
2. Remove the four screws holding the panel to the console and the two screws holding the panel to the top.

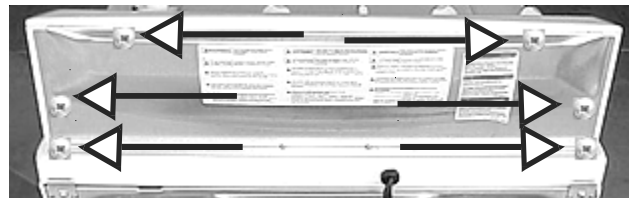

Removing the timer: (some models)

1. Disconnect the washer from electrical supply.
2. Remove the rear panel from the console and the timer knob and skirt.
3. Unplug the two wiring harnesses from the timer.



4. Remove the two screws holding timer to the console panel and pull the timer out the rear.

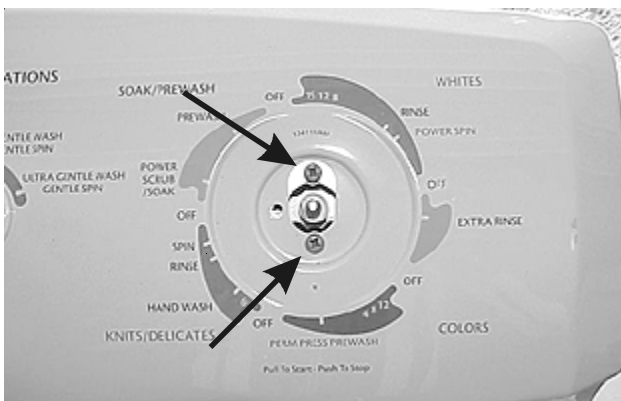

Removing the timer: (some models)

1. Disconnect the washer from electrical supply.
2. Remove the rear panel from the console and the timer knob and skirt.
3. Unplug the wiring harness from the timer.

4. Remove the screw holding the timer to the console front panel.

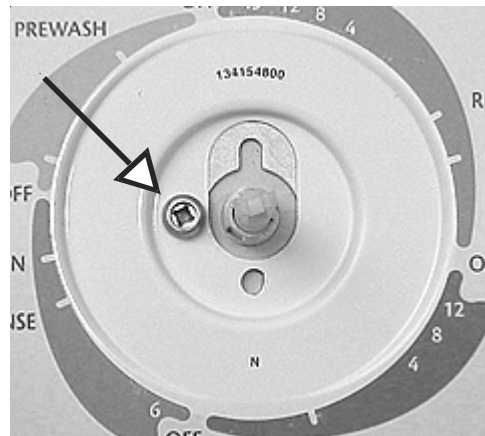

5. From the rear of the console lift timer locking tab and slide the timer to the right to release it from the control mounting plate and pull back on the timer.

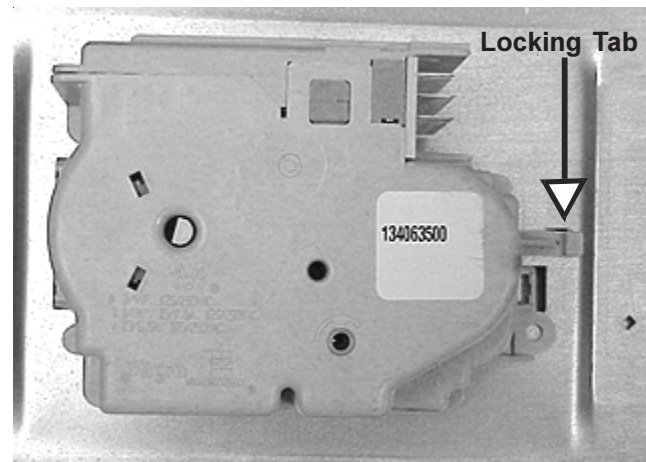

Removing the speed switch, option switch or temp switch:

1. Disconnect the washer from electrical supply.
2. Remove the knob from the switch and the rear panel from the console.
3. Disconnect and mark the wires from the switch.

4. The switch is held to control mounting panel by two spring loaded ramping tabs and a locking tab.

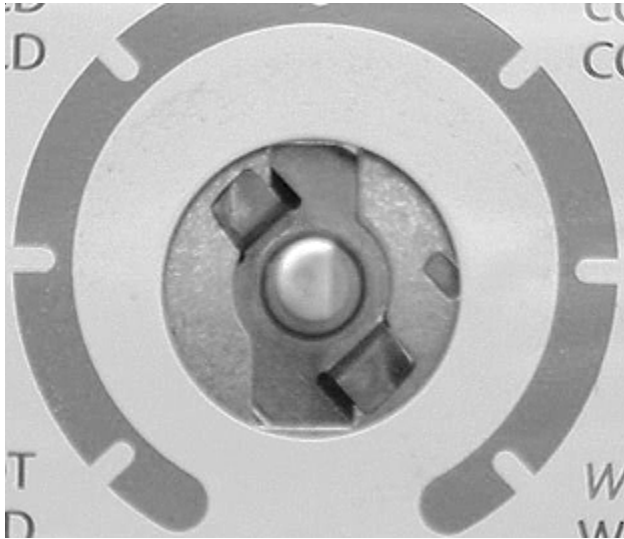

3. The end of cycle signal is held to the control mounting plate by four tabs and a locking pin.

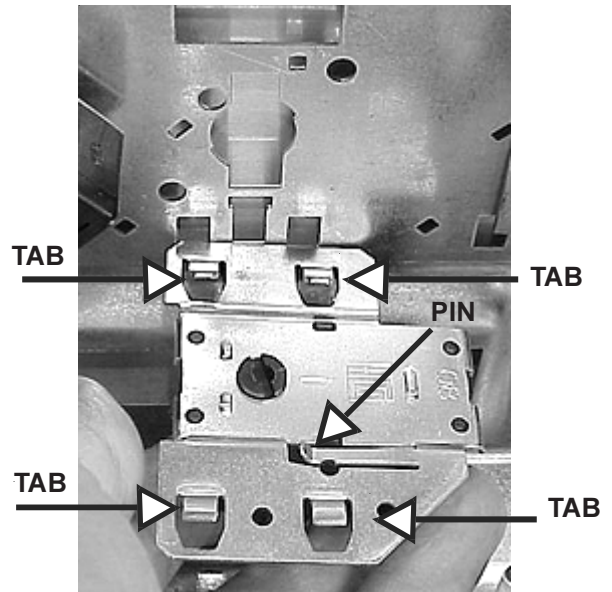

4. Lift the locking pin with a small screwdriver and slide the end of cycle signal down to release the tabs.



5. Use a small screwdriver to lift the locking tab, turn the switch about 1/8 of a turn counter clockwise and pull back on the switch.

Removing the end of cycle signal:

1. Disconnect the washer from electrical supply and remove the rear panel from the console.
2. Disconnect the wires from the end of cycle signal.

Removing the end of cycle signal switch:

1. Disconnect the washer from electrical supply and remove the rear panel from the console.
2. Disconnect the wires from the end of cycle signal switch.

- Squeeze the tabs on the side of the switch and push the switch out the front.

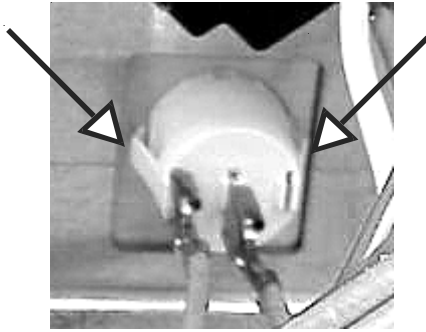

Removing the pressure switch assembly:

- Disconnect the washer from electrical supply.
- Remove the back panel from the console, disconnect the wires from the pressure switch and disconnect the pressure hose.

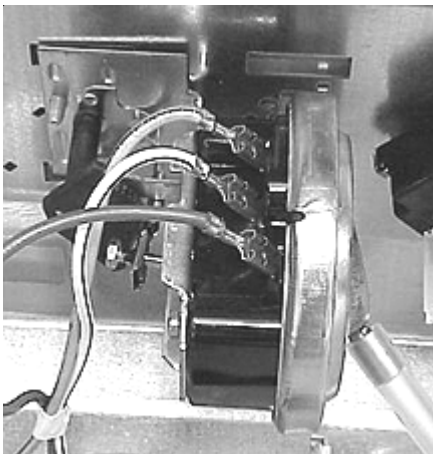

- The pressure switch assembly is held to the control mounting plate by a tab and a screw.

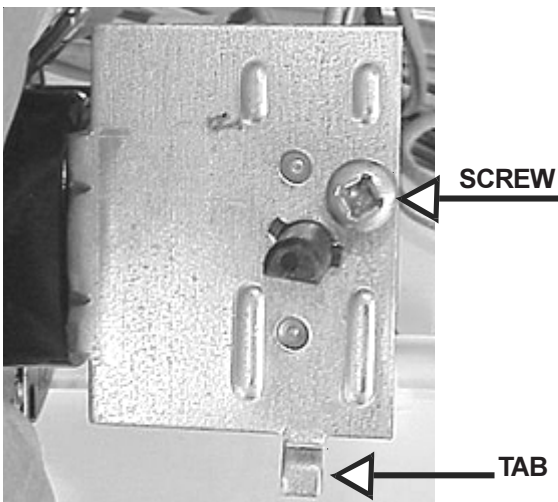

- Remove the pressure switch knob, remove the screw and lift the assembly up

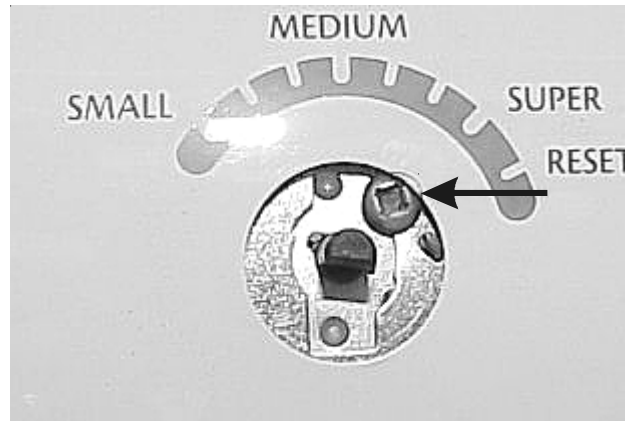

Removing the electronic moisture sensor control:

- Disconnect the washer from electrical supply.
- Remove the back panel from the console and unplug the harness from the electronic moisture sensor control.
- Push up on the top tab to release the control.

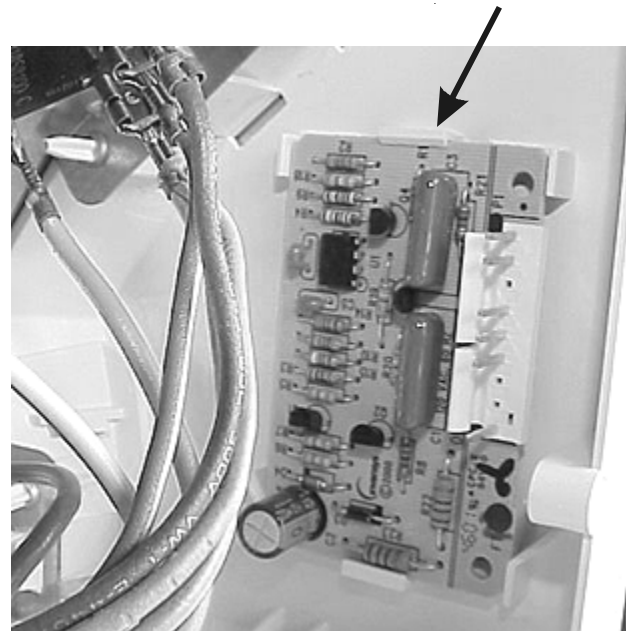

Removing the front closure:

- Disconnect the washer from electrical supply.
- Remove the back panel from the console.

3. With a small screwdriver, release the two tabs in the center and the two tabs on each end that hold the front closure to the end caps and console mounting panel.

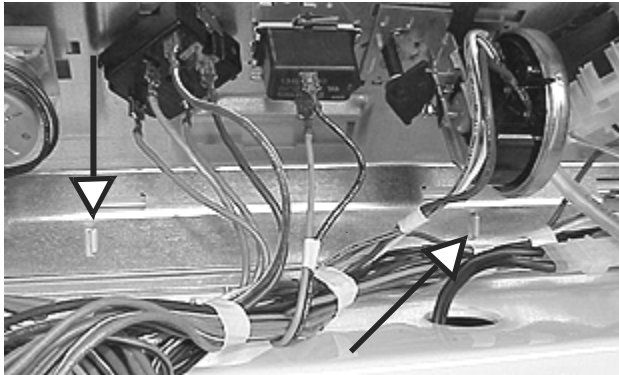

3. The console is held to the top panel by three slotted tabs molded into each end cap and two screws behind the front closure. Remove the two screws, slide the console forward and lift up.

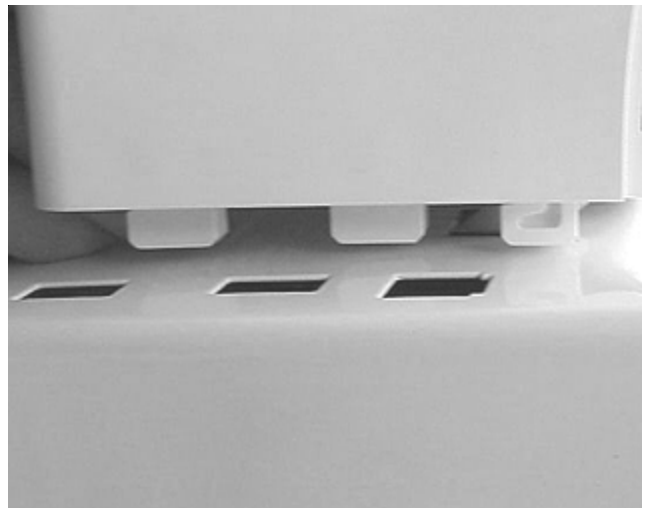
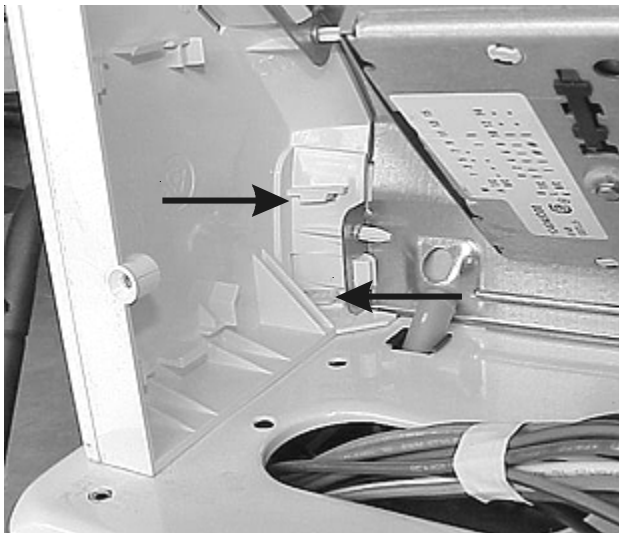

Removing the console:

1. Disconnect the washer from electrical supply.
2. Remove the back panel and skirt from the console and disconnect the components from the console.

Removing the end caps:

1. Disconnect the washer from electrical supply.
2. Disengage the console from the top.
3. Release the two tabs at the top and one tab at the front.

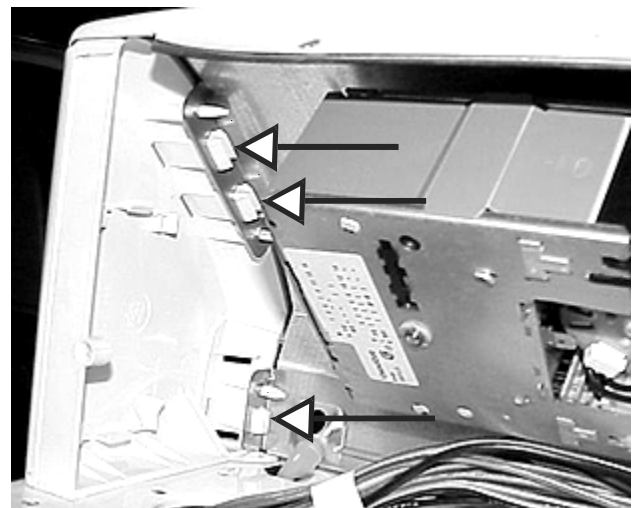

Removing the console's front panel:

1. Disconnect the washer from electrical supply.
2. Remove the knobs and front closure from the console.
3. Remove the lower screw holding the timer and roll the top of the panel forward to disengage bottom tabs of the panel.

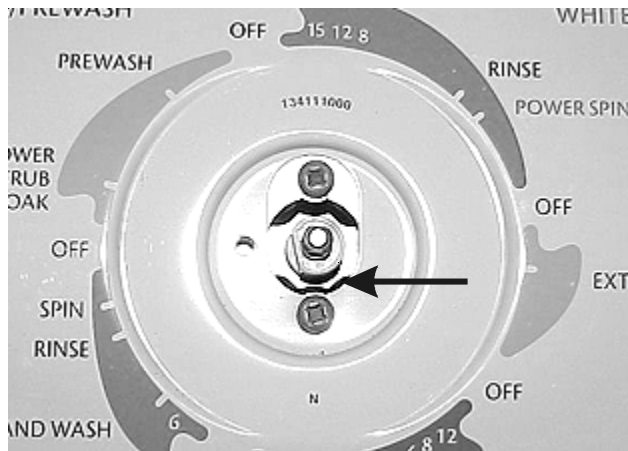

Removing the lid lock assembly:

1. Disconnect the washer from electrical supply.
2. Raise the top and disconnect the wires from the lid lock assembly.
3. Remove the two screws holding the lid lock assembly to the top and slide the assembly away from the top.

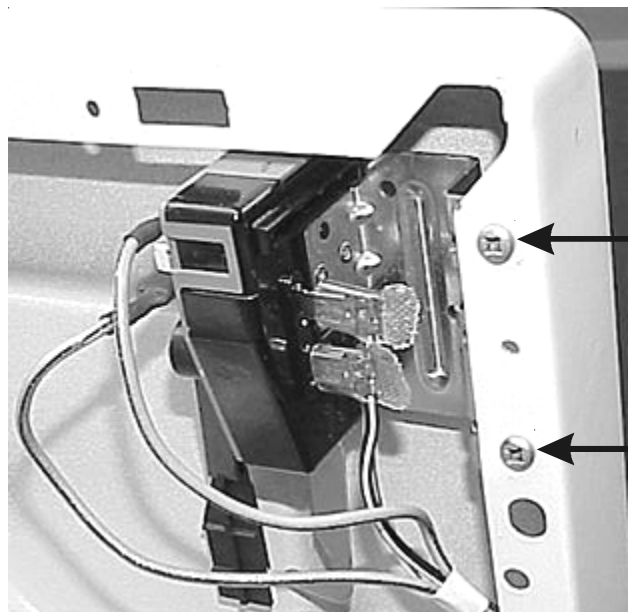

Removing the lid hinges:

1. Disconnect the washer from electrical supply.
2. Raise the top and remove the spring if removing the left hand hinge.
3. Remove the two screws holding the hinge to the lid.

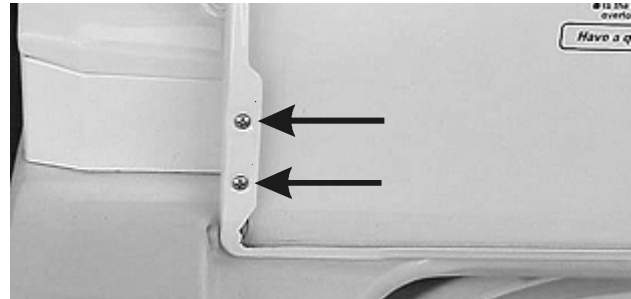

4. Pull the hinge in and rotate the end of the hinge counter clockwise while pulling.



Removing the lid spring:

1. Disconnect the washer from electrical supply.
2. Raise the top, raise the lid, unhook the spring from the top and turn the other end of the spring out of the lid hinge.



Removing the lid:

1. Disconnect the washer from electrical supply.
2. Remove the hinges and lift the lid off.



Removing the water inlet nozzle assembly:

1. Disconnect the washer from electrical supply.
2. Raise the top, disconnect the hose from the water valve.



Note: If equipped with ATC, disconnect wires from ATC.

3. Remove the one screw holding the nozzle to the top.

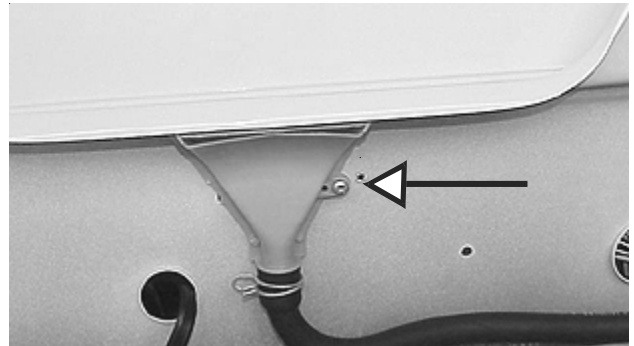

Removing the bleach dispenser:

1. The bleach dispenser is snapped into the top. Place a screwdriver underneath the front corner and pop the dispenser out.



Replacing the top:

1. Disconnect the washer from electrical supply.
2. Remove the console and disconnect the ground wire.
3. Raise the top, unfasten the lid lock assembly, the wiring to the lid lock assembly and nozzle assembly from the top.
4. Remove the lid and the dispenser top.
5. Disconnect the line cord, pull the wiring and pressure hose through the opening in the top and lift the top off the hinges.

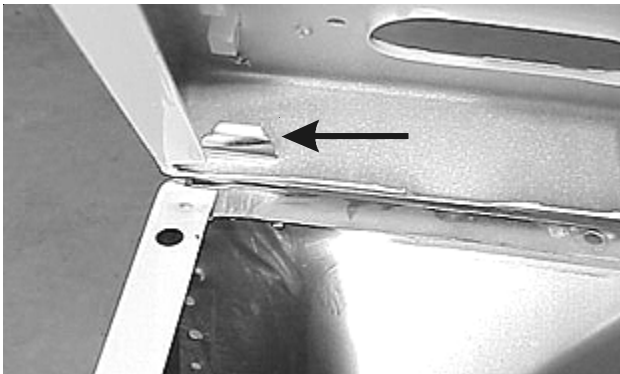

Removing the top hinges:

1. Gain access to the rear of the washer, remove the one screw holding the hinge to the rear panel and pull and rotate the hinge up.

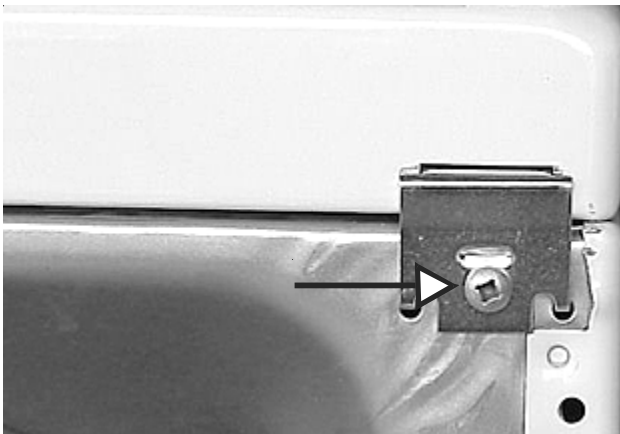

Removing the water inlet valve:

1. Disconnect the washer from electrical supply, turn the water off and raise the top.

2. Disconnect the wiring and hoses from the valve.

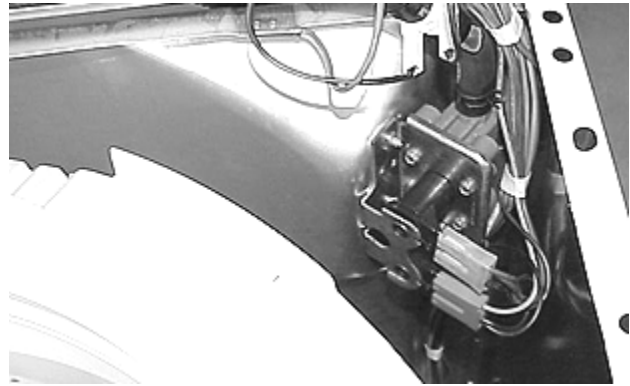

3. Gain access to the rear of the washer and remove the two screws holding the valve to the rear panel.

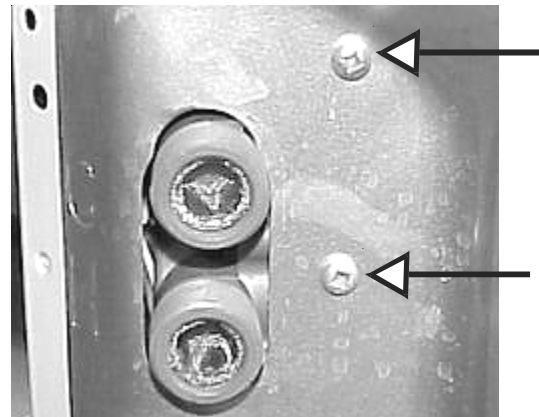

Alternate water valve attachment:

3. Gain access to the rear of the washer and remove one screw holding the valve to the rear panel.

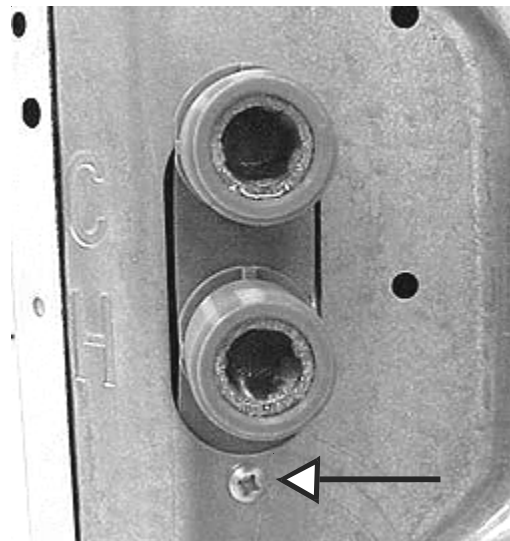

Removing the ATC sensor:

1. Disconnect the washer from electrical supply and raise the top.
2. Unplug the wiring harness from the sensor and remove the water inlet assembly.

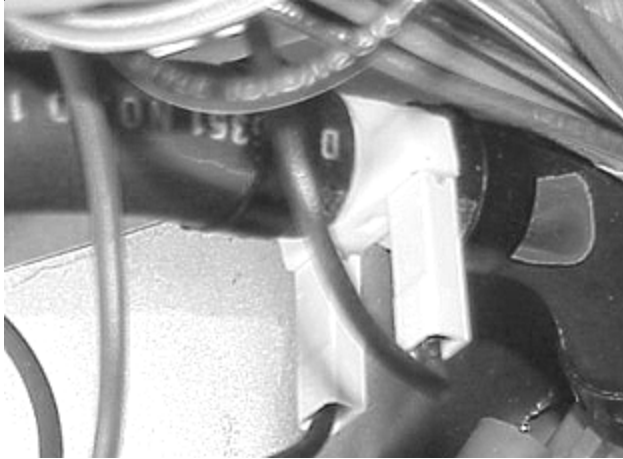

Removing the front panel:

1. Disconnect the washer from electrical supply and raise the top.
2. Remove the two screws at the bottom of the panel and slide the panel down to release the tabs from the side panels.



Removing the drain pump:

Note: There will be water in the pump so have a pan or towels to catch it before disconnecting the pump.

1. Disconnect the washer from electrical supply and remove the front panel.
2. Unplug the wiring from the drain pump and remove the one screw holding the drain pump shield to the pump (if equipped). Release the tab and pull the shield back.

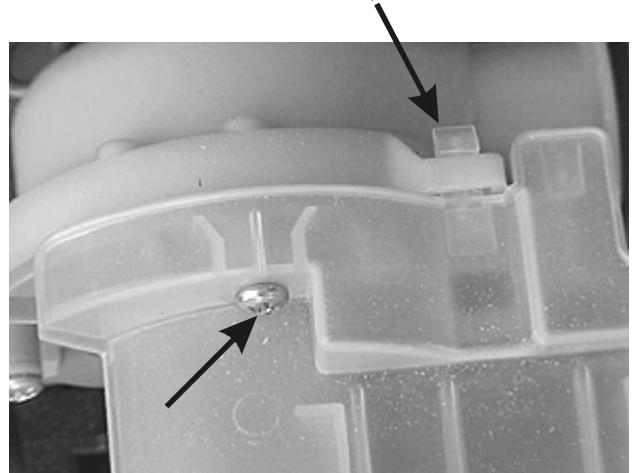

3. Disconnect the hoses and remove the two screws holding the pump to the washer base.

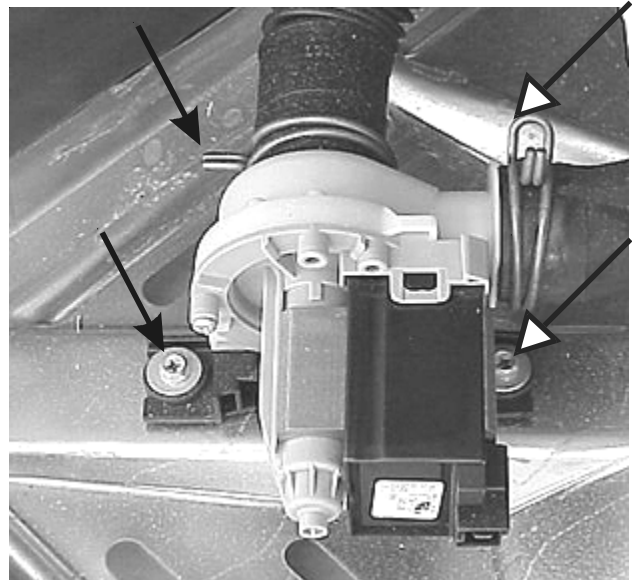

2. Remove the mechanism cap by placing a cloth between pliers jaws and grasping the handle on the cap. Pull upward firmly until cap pops out.



Reinstalling the mechanism cap:

1. Wipe the mechanism cap o-ring and sealing surface inside the upper agitator with a dry cloth to remove any foreign material that might prevent a proper seal. Do not wash out the agitator mechanism or contaminate it with any liquid. Reinstall the mechanism cap by placing one side of the cap under the plastic ridge at the level of the upper agitator softener holes. Push the cap firmly downward. Using a padded instrument such as a rubber coated pliers handle or a cushioned hammer handle, work around the cap edge using light vertical blows until seated. Excessive force may crack the cap.

Then check the installation by:

- a. Making sure the o-ring is properly seated in the groove on the cap before installation.
- b. Looking for the black o-ring through the softener holes in the upper agitator. The cap is not properly installed if any black can be seen.
- c. Check that the entire edge of the mechanism cap is under the four plastic ridges on the inside of the upper agitator.

Removing the agitator:

1. Raise the top, remove the softener dispenser and lift the cap out.
2. Using a 1/2" socket remove the bolt from the center of the agitator shaft and lift the agitator off.

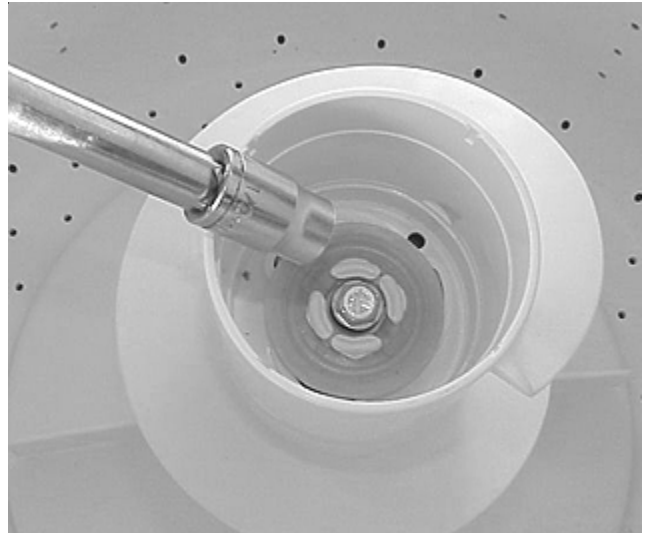

Removing the drive hub:

1. The drive hub is forced on the transmission shaft by the bolt that holds the agitator to the transmission shaft.
2. Place a screwdriver between transmission shaft and the drive hub and force the drive hub off.

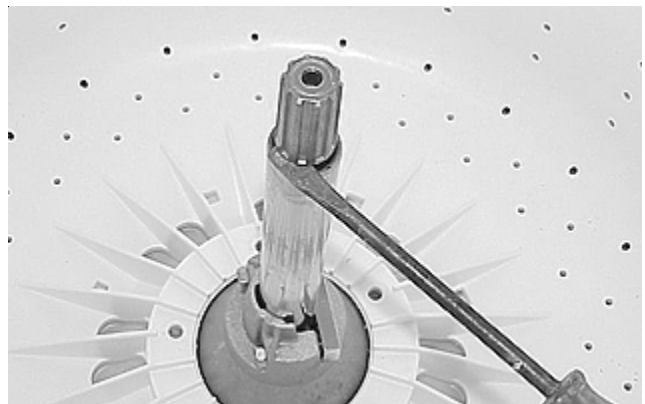

Removing the splash tub cover:

1. Disconnect the washer from electrical supply.
2. Raise the top and remove the front panel.
3. Unsnap the pressure hose from the cover.

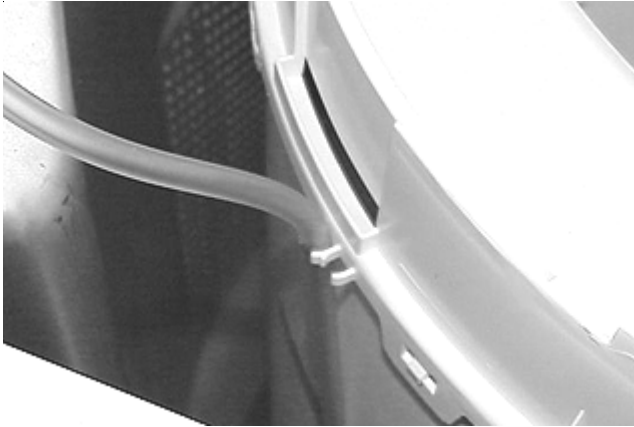

4. Using a screwdriver unsnap the cover from the tub and lift it off.



Removing the spin basket:

1. Disconnect the washer from electrical supply.
2. Remove the agitator and the splash tub cover.
3. Using a 1/2" socket remove the five bolts holding the spin basket to the trunnion.

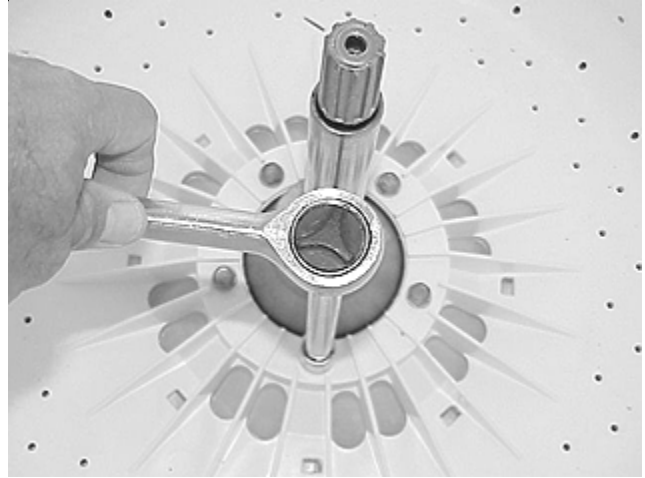

Removing the trunnion:

1. Disconnect the washer from electrical supply.
2. Remove the agitator, splash tub cover and spin basket.
3. Using a 1/2" socket loosen the two bolts holding the lockplate to the agitator shaft and lift the trunnion off the shaft.

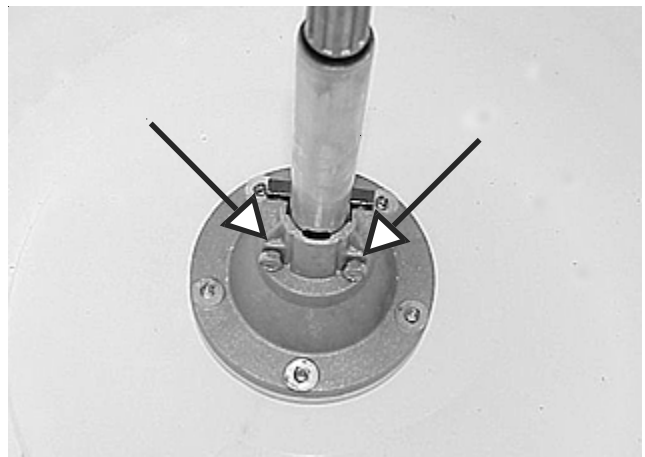

Removing the top half of the tub seal:

1. Disconnect the washer from electrical supply.
2. Remove the agitator, spin basket and trunnion.
3. Push down on the brass ring to release the rubber seal and pull the seal and brass ring off the shaft.



Removing the bottom half of the tub seal:

1. Disconnect the washer from electrical supply.
2. Remove the agitator, spin basket, trunnion and top half of the tub seal
3. Place your thumbs on the bottom seal towards you and your fingers on the other side. Push down and in with your thumbs and pull in and up with your fingers to pop the seal out.



Removing the outer tub:

1. Disconnect the washer from electrical supply.
2. Remove the agitator, spin basket, trunnion and top half of the tub seal.
3. Disconnect the drain hose, drive motor shield and the pressure switch hose.
4. Using a 1/2" socket remove the three bolts holding the tub to the leg and dome assembly, and lift the tub over the transmission shaft.

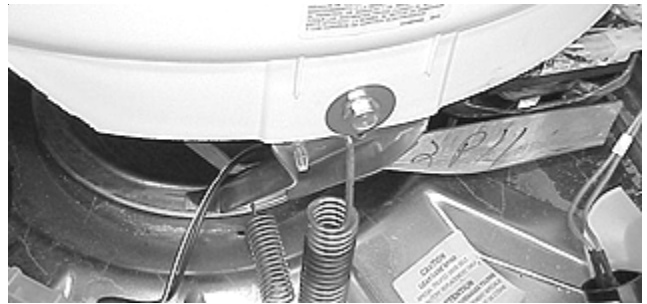

Removing the tub bearing:

1. Disconnect the washer from electrical supply.
2. Remove the agitator, spin basket, trunnion, top half of the tub seal and tub.
3. Turn the tub over and remove two screws holding the bearing to the tub.

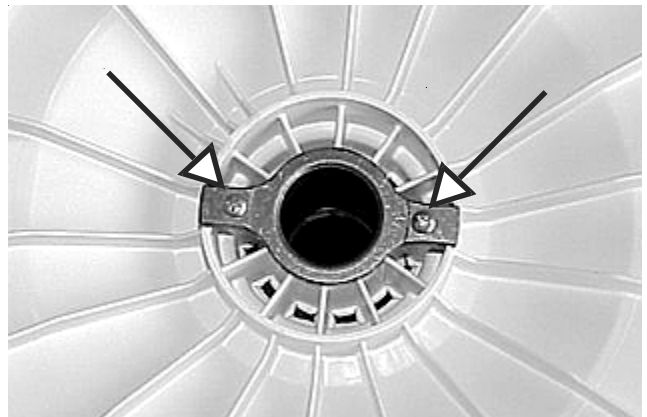

Removing the drive belt:

1. Disconnect the washer from electrical supply and remove the front panel.
2. Check the setting of idler pulley spring.

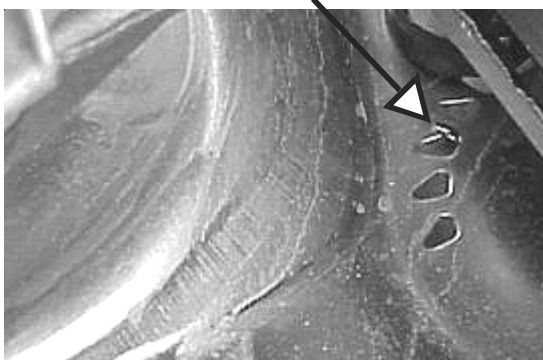

3. Push in on the idler pulley and turn the belt off.



Removing the transmission pulley:

1. Disconnect the washer from electrical supply, remove the front panel and the drive belt.
2. Using a 3/8" socket, loosen the locking screw of the transmission pulley and drop the pulley off the shaft.

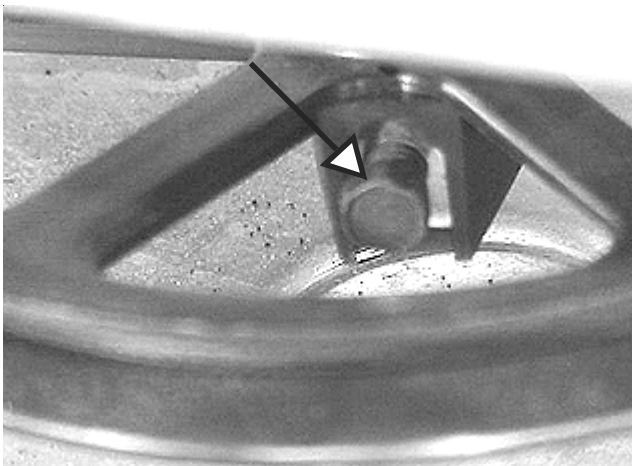

Removing the transmission:

1. Disconnect the washer from electrical supply, remove the front panel and the drive belt.
2. Remove the agitator, spin basket, trunnion, tub and transmission pulley.
3. Using a 3/8" socket remove the two bolts holding the transmission bearing block to the transmission mounting plate and remove transmission.

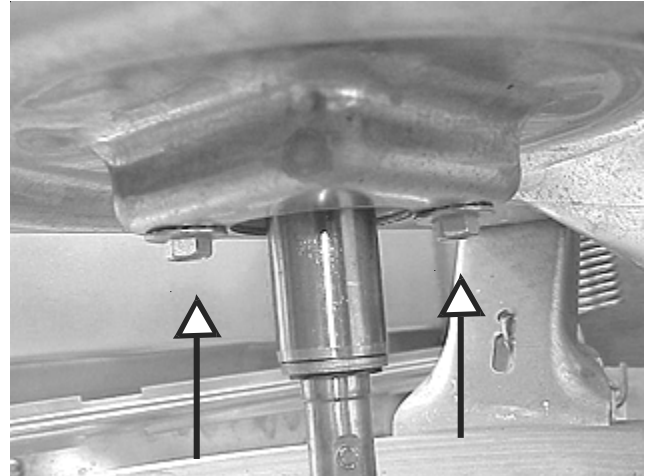

Replacing the vertical springs:

1. Disconnect the washer from electrical supply and remove the front panel.
2. The three vertical springs are not the same. The springs are identified by two them being painted. The spring without the paint goes in the left rear across from the motor.



Removing the idler pulley assembly:

1. Disconnect the washer from electrical supply, remove the front panel and the drive belt.
2. Release the front vertical and horizontal springs.
3. Release the small “C” clip from the transmission stud and allow the assembly to drop down.

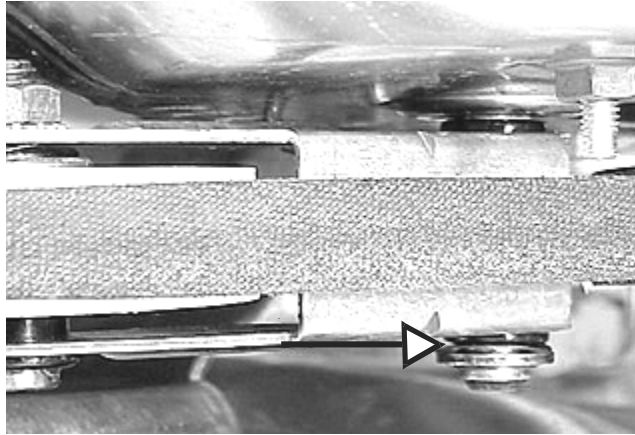

Note: The “C” clip is very small and hard to find if dropped.

Removing the snubber:

1. Disconnect the washer from electrical supply and remove the front panel.
2. Make a wire hook to pull the snubber out with.



Caution: Never place your hands or fingers under the leg and dome assembly while it is raised.

3. Release the front vertical and horizontal springs.
4. Place a 2” by 4” between the bottom rim of the leg and dome assembly and the base and raise the leg and dome assembly.

Note: It is a good idea to be prepared with some sort of supports (like 3/4 inch pieces of wood) to slide between the lower edge of the assembly and the base to help support it if it were to slide off of your pry-bar.

5. Pull the snubber out with the wire hook.

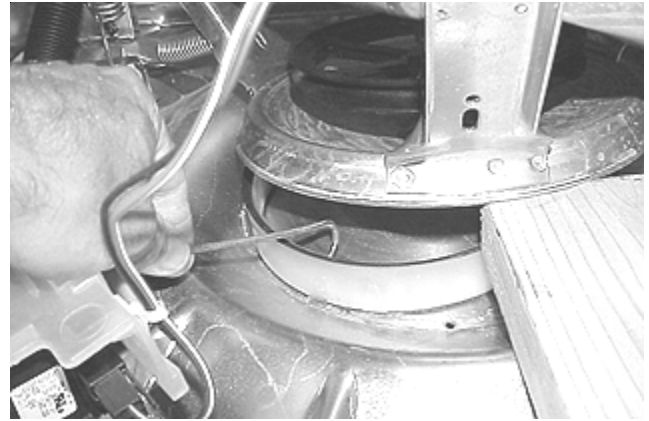

Reinstalling the snubber:

Before reinstalling the snubber the base must be wiped out whether the snubber is replaced or not. A cloth wetted with denatured (camp stove) alcohol or rubbing alcohol will clean any residue, such as soap, or fabric softener off of the base and will also cut any waxes or oils that may have been missed by the factory, during assembly. An old cloth work glove would work well also. Make sure that the snubber area is wiped out well.

Note : Never oil the base to stop snubber noise.

Inspect the teflon strips on upper and lower edges of the snubber they must be perfectly smooth and undamaged in any way.

Note: The arrow on the side of the snubber. When reinstalling or replacing the part, the arrow must be pointing upward.

Removing the drive motor shield:

1. Disconnect the washer from electrical supply and remove the front panel.
2. Disconnect the wires from the capacitor, remove the two screws holding the shield to the tub and rotate the shield down and out.

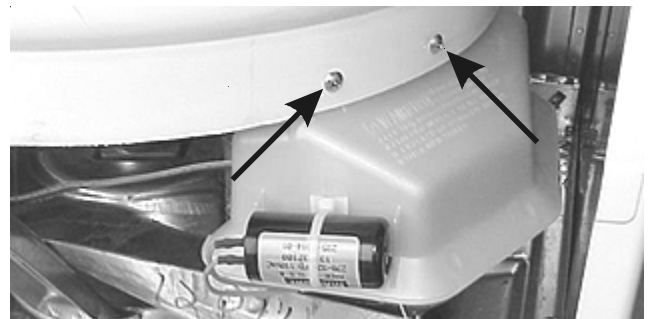

Removing the start capacitor:

1. Disconnect the washer from electrical supply and remove the front panel.
2. Disconnect the wires from the capacitor and remove the drive motor shield.
3. Release the strap plastic rivet to release the capacitor from the shield.

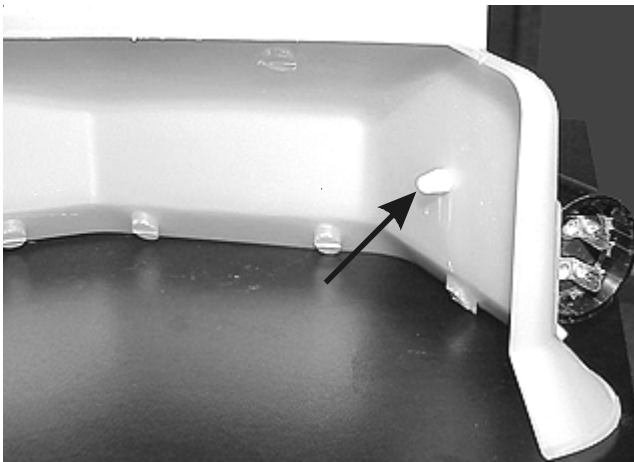

4. Remove the drive belt and (depending on the model) disconnect the wiring harness or harnesses from the drive motor.



5. Using a 3/8" wrench, remove the four nuts from the motor studs, lift the motor up, tip it back and pull the motor out the front.

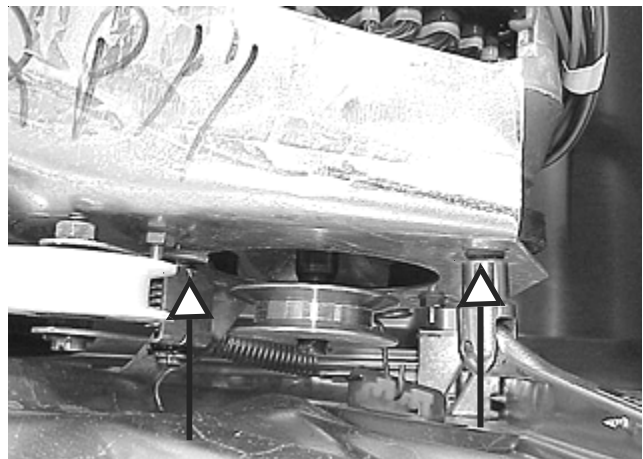

Removing the drive motor:

1. Disconnect the washer from electrical supply and remove the front panel.
2. Remove the front vertical and horizontal springs, disconnect the wires from the capacitor and remove the drive motor shield.
3. Remove the bolt from the front leg, raise the tub, reinsert the bolt so that the bottom of the tub rests on the bolt to raise the tub.

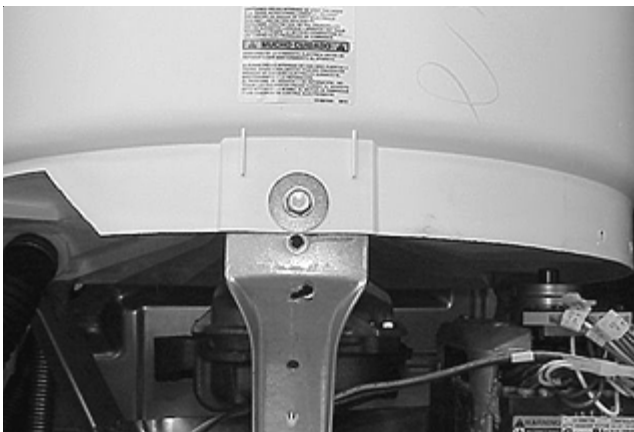

Removing the leg and dome assembly:

1. Disconnect the washer from electrical supply, remove the front panel and disconnect the front vertical and horizontal springs.
2. Remove the three bolts holding the leg and dome assembly to the tub.
3. Remove the drive belt and the transmission pulley.
4. Disconnect the tub drain and the pressure switch hoses.
5. Remove the two bearing block bolts holding the transmission to the transmission mounting plate and lift the tub assembly and transmission out of the washer.

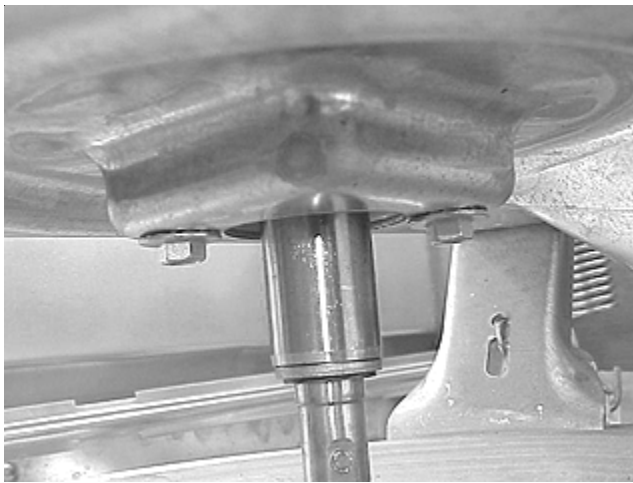

6. Unplug the wiring harnesses from the drive motor and drain pump.
7. Release the plastic rivets holding the wiring harness to the legs and the two rear horizontal and vertical springs.



8. Lift the leg and dome assembly out of the washer.
9. Remove the drive motor and the idler pulley.

Removing the base:

1. Disconnect the washer from electrical supply and remove the front panel.
2. Remove the drain pump and disconnect the pressure switch hose.
3. Unplug the wiring harness from the drive motor and remove the plastic rivets holding the wiring harness to the leg and dome assembly.
4. Remove the three vertical and horizontal springs holding the leg and dome assembly to the base.
5. Lift the tub and the leg and dome assembly out of the washer.
6. Remove the snubber.
7. Remove the three screws from each side and the one screw in back holding the panels to the base.

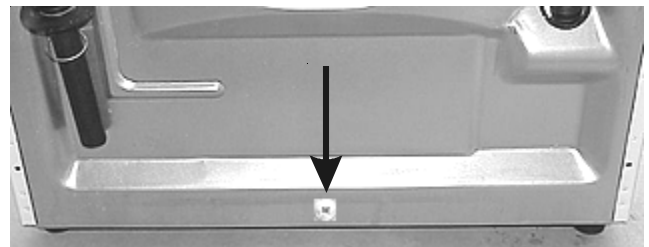
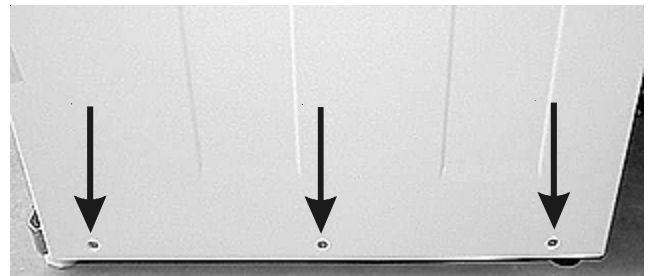

8. Slide the base out the front.

