

GE 24inch Front Load Washer

Models:

WCVH4800KWW

WCVH4815KMS

(MS = Metallic Silver)

Service Guide --- 31-9195



imagination at work

GWS 11/12/09

IMPORTANT SAFETY NOTICE

The information in this presentation is intended for use by individuals possessing adequate backgrounds of electrical, electronic, & mechanical experience. Any attempt to repair a major appliance may result in personal injury & property damage. The manufacturer or seller cannot be responsible for the interpretation of this information, nor can it assume any liability in connection with its use.

WARNING

To avoid personal injury, disconnect power before servicing this product. If electrical power is required for diagnosis or test purposes, disconnect the power immediately after performing the necessary checks.

RECONNECT ALL GROUNDING DEVICES

If grounding wires, screws, straps, clips, nuts, or washers used to complete a path to ground are removed for service, they must be returned to their original position & properly fastened.

GE Factory Service Employees are required to use safety glasses with side shields, cut resistant (Dyneema®) gloves & steel toe shoes for all repairs.



Dyneema® Cut Resistant Glove



Steel Toe Shoes



Plano Safety Glasses

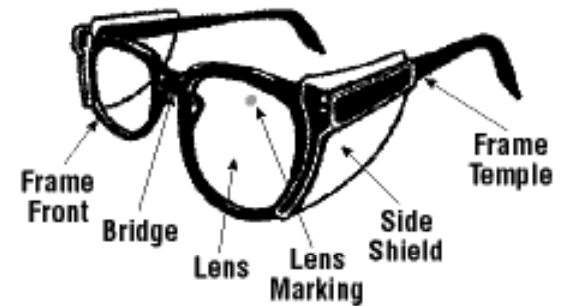

Prescription Safety Glasses

Safety Glasses must be compliant with ANSI Z87.1-2003

Warranty

For The Period Of:	We Will Replace:
One Year From the date of the original purchase	Any part of the washer which fails due to a defect in materials or workmanship. During this limited one-year warranty , Mabe will also provide, free of charge , all labour and related service costs to replace the defective part.

What Is Not Covered (in Canada):

- Service trips to your home to teach you how to use the product.
- Improper installation, delivery or maintenance.
- Failure of the product if it is abused, misused, or used for other than the intended purpose or used commercially.
- Damage after delivery.
- Replacement of house fuses or resetting of circuit breakers.
- Damage to the product caused by accident, fire, floods or acts of God.
- Incidental or consequential damage caused by possible defects with this appliance.
- Product not accessible to provide required service.

EXCLUSION OF IMPLIED WARRANTIES—Your sole and exclusive remedy is product repair as provided in this Limited Warranty. Any implied warranties, including the implied warranties of merchantability or fitness for a particular purpose, are limited to one year or the shortest period allowed by law.

Nomenclature

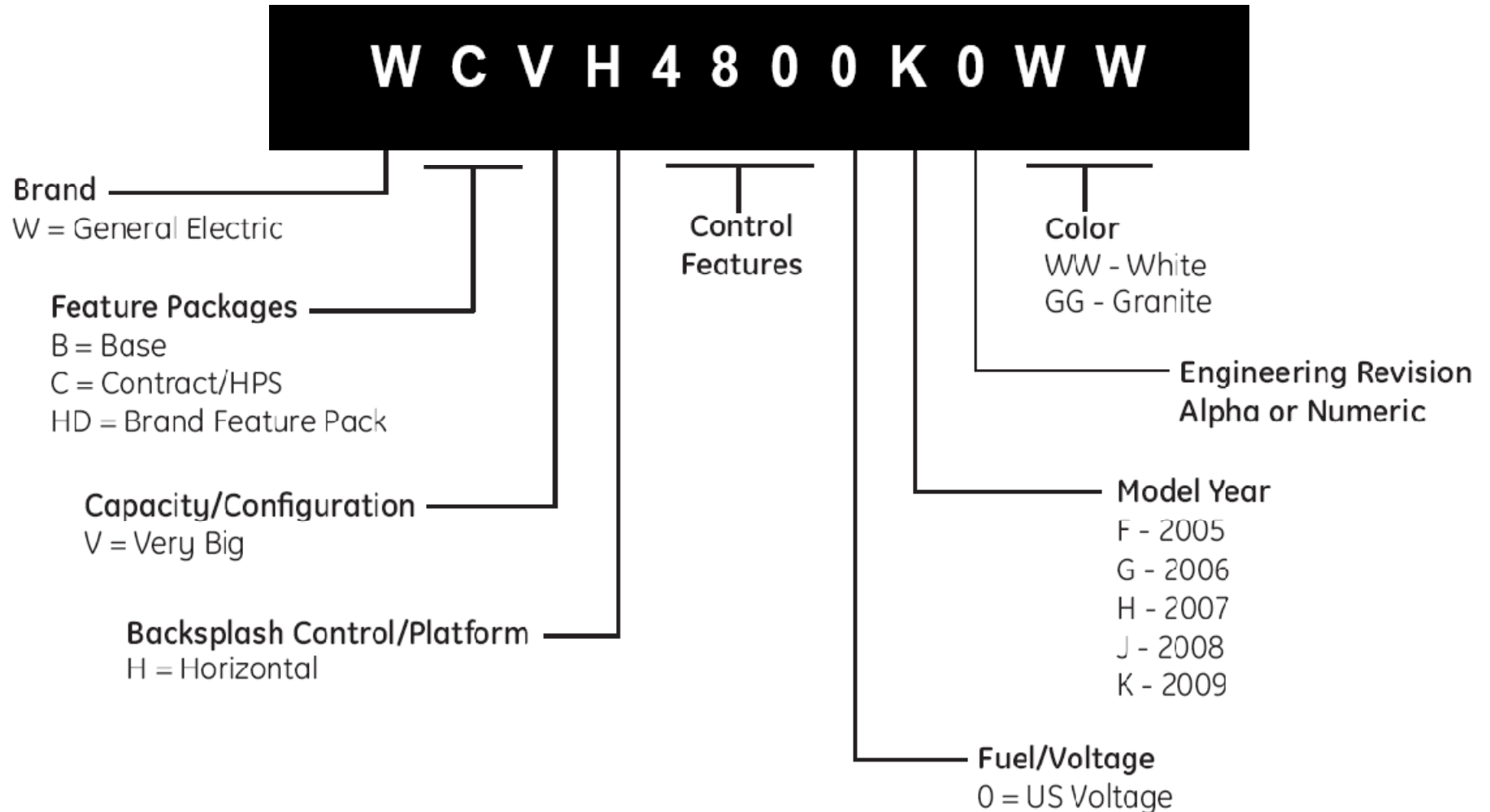

Model / Serial Number Plate



- Model / Serial plate located behind door on upper left side & also on the rear of the machine to the left of the water valves.

NOTE: Touch up Paint for Metallic Silver Models – WR97X10124

Mini-Manual



- Mini-Manual is in a plastic envelope and taped to dispenser assembly under washer top.

Demo Mode

To enter DEMO Mode:

1. Unplug the washer.
2. Open the door.
3. Wait 30 seconds.
4. Restore power to washer.
5. Press Start / Pause 4 times with 30 seconds of applying power.

In demo mode, the only components that will function are the control LEDs. No other components will operate. The count down display will run much faster than normal.

To exit DEMO mode:

Same procedure as entering demo mode.

NOTE: Removing power from machine will not exit demo mode.

Control Panel Selections



BASKET CLEAN --- To clean drum and reduce odor.

NOTE: Basket Clean is a special cycle used to clean the washer drum and reduce odor. DO NOT add garments to this cycle. Remove detergent cup and add one cup of bleach or other commercially available product manufactured for this purpose, such as Tide® Washing Machine Cleaner.

Basket Clean - Cycle Definition

- Customer adds 1 cup of bleach into the basket
- Customer activates the Basket clean Cycle
- One cleaning cycle with bleach followed by 2 rinse cycles and final spin
- Total cycle time 1 hour 26 minutes

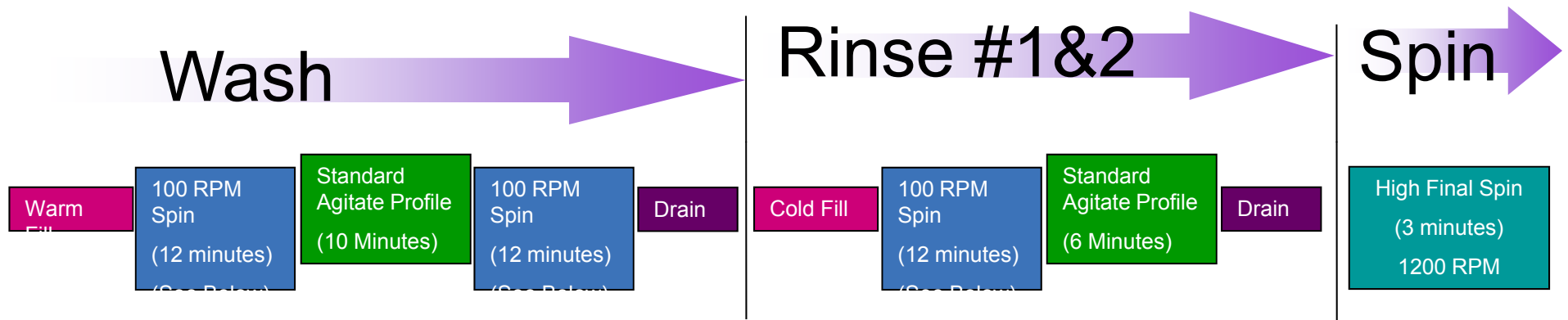

100 RPM Profile

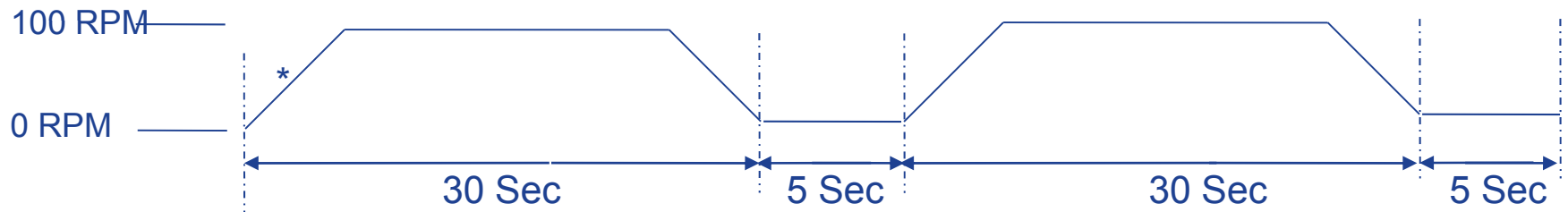

* Ramp up to 100rpm and down from 100RPM as fast as possible

Wash Cycle Defaults

- When a cycle is initially set, the default cycle settings are displayed.
- The following table displays the default selections for each cycle.

No.	Cycles	Soil	Spin	Temp	Extra Rinse	Signal	Delay Start	Default cycle time
1	Whites/Heavy Duty	Heavy	High	Hot	N/A	On/Off	N/A	1:15
2	Colors/Normal	Normal	High	Warm	N/A	On/Off	N/A	56
3	Wrinkle Free	Normal	Mid	Warm	N/A	On/Off	N/A	52
4	Active Wear	Normal	Mid	Warm	N/A	On/Off	N/A	50
5	Delicates	Normal	Low	Warm	N/A	On/Off	N/A	40
6	Hand Wash	Normal	Low	Warm	N/A	On/Off	N/A	32
7	Speed Wash	Light	High	Warm	N/A	On/Off	N/A	30
8	Rinse/Spin	N/A	High	N/A	N/A	On/Off	N/A	19
9	Drain/Spin	N/A	High	N/A	N/A	On/Off	N/A	14
10	Basket Clean	N/A	N/A	N/A	N/A	On/Off	N/A	1:26

NOTE: Washer incorporates an adaptive fill algorithm which fills with only the amount of water to match the load size.

Wash Cycle Options

- Depending upon the selected wash cycle, not all of the wash cycle selections shall be accessible.
- The following table outlines allowable cycle ranges.

No	Cycles	Soil	Spin	Temp	Extra Rinse	Signal	Delay Start
1	Whites/Heavy Duty	All	All	All	Selectable	On/Off	Selectable
2	Colors/Normal	All	All	Tap Cold, Cold, Warm, Hot	Selectable	On/Off	Selectable
3	Wrinkle Free	Extra Light, Light, Normal, Heavy	No Spin, Low, Medium, High	Tap Cold, Cold, Warm, Hot	Selectable	On/Off	Selectable
4	Active Wear	Extra Light, Light, Normal, Heavy	No Spin, Low, Medium, High	Tap Cold, Cold, Warm, Hot	Selectable	On/Off	Selectable
5	Delicates	Extra Light, Light, Normal, Heavy	No Spin, Low, Medium	Tap Cold, Cold, Warm	Selectable	On/Off	Selectable
6	Hand Wash	Extra Light, Light, Normal	No Spin, Low	Tap Cold, Cold, Warm	N/A	On/Off	Selectable
7	Speed Wash	Extra Light, Light, Normal	No Spin, Low, Medium, High	Tap Cold, Cold, Warm	Selectable	On/Off	Selectable
8	Rinse/Spin	N/A	All	N/A	Selectable	On/Off	Selectable
9	Drain/Spin	N/A	All	N/A	N/A	On/Off	Selectable
10	Basket Clean	N/A	N/A	N/A	N/A	On/Off	N/A

NOTE: Washer incorporates an adaptive fill algorithm which fills with only the amount of water to match the load size.

Spin Speeds

Speed	RPM
No Spin	0
Low	400 +/- 50 RPM
Medium	650 +/- 50 RPM
High	1200 +/- 50 RPM
Extra High	1400 +/- 50 RPM

Cycle / Time Chart

	Wash												Rinse1						Rinse2				Spin						Reverse		DISPLAY									
	Filling		Wash		Drain		Spin1		Spin2		Stop		Filling		Rinse		Drain		Spin1		Spin2		Stop																	
	Min	Sec	Min	Sec	Min	Sec	Min	Sec	Min	Sec	Min	Sec	Min	Sec	Min	Sec	Min	Sec	Min	Sec	Min	Sec	Min	Sec	Min	Sec	Min	Sec	Min	Sec	Hour	Min								
White/Heavy duty	2	0	37	0	1	0	2	17	2	15	0	30	2	0	3	0	1	0	2	17	2	15	0	30	2	0	3	0	1	0	2	17	8	18	0	30	1	0	1	15
colors/normal	2	0	18	0	1	0	2	17	2	15	0	30	2	0	3	0	1	0	2	17	2	15	0	30	2	0	3	0	1	0	2	17	8	18	0	30	1	0	0	56
wrinkle free	2	0	16	0	1	0	2	17	2	15	0	30	2	0	3	0	1	0	2	17	2	15	0	30	2	0	3	0	1	0	2	17	6	12	0	30	1	0	0	52
Active Wear	2	0	15	0	1	0	2	17	1	45	0	30	2	0	3	0	1	0	2	17	1	45	0	30	2	0	3	0	1	0	2	17	6	12	0	30	1	0	0	50
Delicate	2	0	13	0	1	0	2	17	0	30	0	30	2	0	3	0	1	0	2	17	0	30	0	30	2	0	3	0	1	0	2	17	2	10	0	30	0	0	0	40
Handwash	2	0	14	0	1	0	0	0	0	0	0	0	2	0	2	0	1	0	0	0	0	0	0	0	2	0	2	0	1	0	2	17	1	30	0	30	0	0	0	32
speed wash	2	0	7	0	1	0	2	17	0	0	0	30	1	0	2	0	1	0	2	17	0	0	0	30	1	0	2	0	1	0	2	17	3	12	0	30	0	0	0	30
Basket clean	2	0	34	0	1	0	0	0	0	0	0	0	2	0	18	0	1	0	0	0	0	0	0	0	2	0	18	0	1	0	2	17	4	12	0	30	0	0	1	26
Rinse+Spin																							2	0	3	0	1	0	2	17	8	18	0	30	1	0	0	19		
Drain + Spin																									1	0	2	17	8	18	0	30	1	0	0	14				

Out of Balance Mode

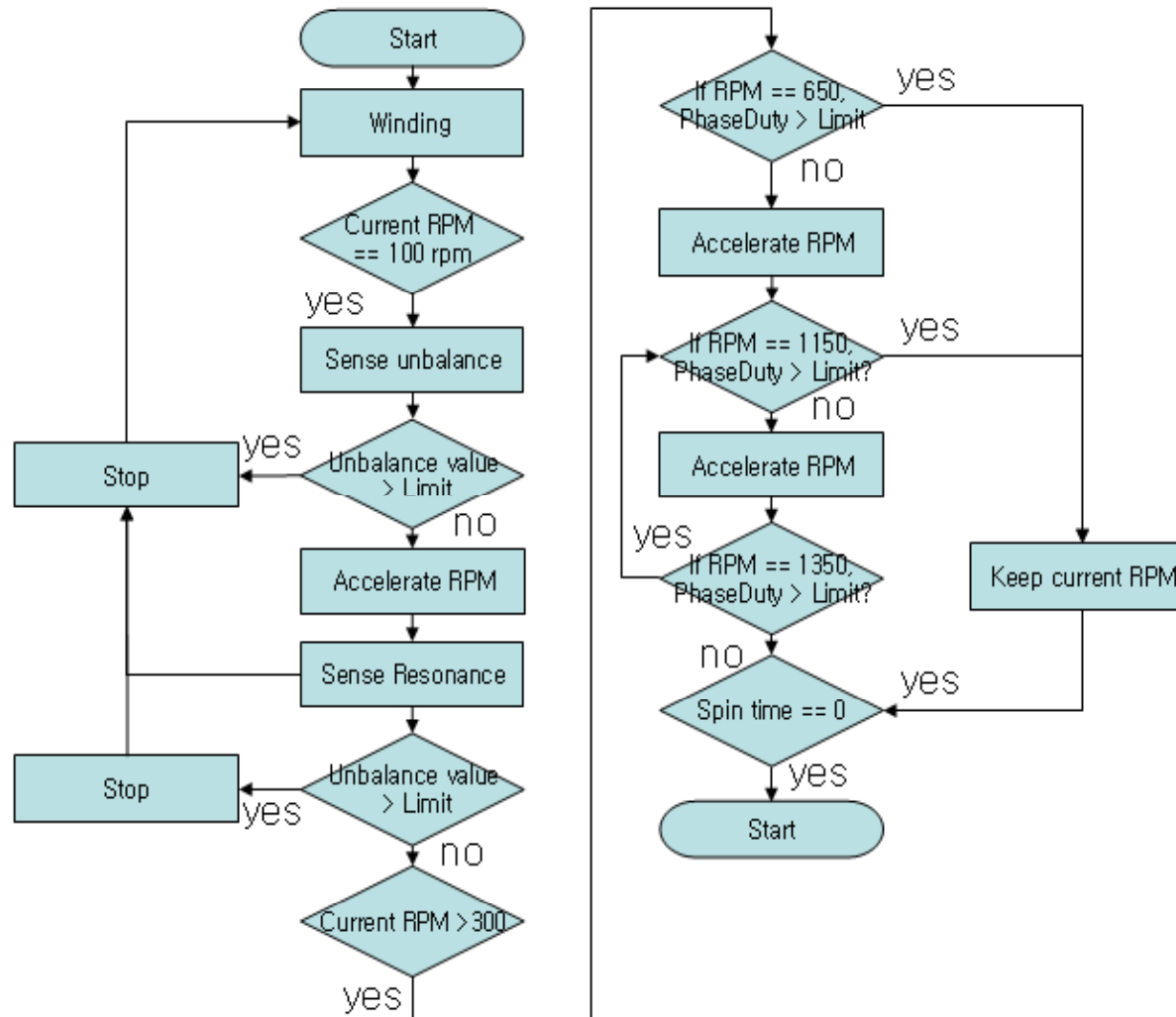

- Sensing unbalance uses RPM fluctuation so that it can check to take balance or not.
- Sensing Resonance use duty data of motor control so that it can check to take balance or not.

Out of Balance Mode

1. Before spinning, control will initiate a short agitate cycle to re-distribute clothes.
2. Spin cycle begins. At @ 100RPM, control will sense for an unbalanced load.
3. If an unbalance is sensed, the control will go back to step #1, add time to timer and try again. If no unbalance is sensed, accelerate to @ 300RPM.
4. At @ 300RPM, control will again sense for an unbalanced load.
5. If an unbalance is sensed, the control will go back to step #1, add time to timer and try again. If no unbalance is sensed, accelerate to @ 650RPM.

NOTE: Control will keep trying steps 1 through 5 until it is successful in accelerating past 300RPM or until a total of 12 minutes for the middle spins or 34 minutes for the last spin has been added to the timer. At the 12 or 34 minute point, the control will quit trying and move to the next cycle or stop operation if it was the last spin.

6. At @ 650RPM, if OoB phase is greater than set limit, the control will finish out the the spin cycle at this speed. If it is within limits, it will accelerate to @ 1150RPM.
7. At @ 1150RPM, if OoB phase is greater than set limit, the control will finish out the the spin cycle at this speed. If it is within limits, it will accelerate to @ 1350RPM.
8. At @ 1350RPM, if the OoB phase is above the set limit, it will de-accelerate to @ 1150RPM and continue at that speed until cycle times out.

NOTE: Control will execute the above scenario for each spin in wash cycle.
If 34 minutes needs to be added to timer after the final spin the control will log an “UE” error code to the service mode.

Dispenser Drawer



- Remove detergent insert (left side) for powder detergent.
- Liquid bleach only. (right side)
- Press down on tab in softener compartment to release drawer for removal.

Dispenser Drawer



View of dispenser with drawer removed.

Machine Top



To lift washer top, first remove two large Phillips screws from both rear corners.

Machine Top



After removing screws, slide top to the rear @ one inch.
Lift top from washer.

Top Component View

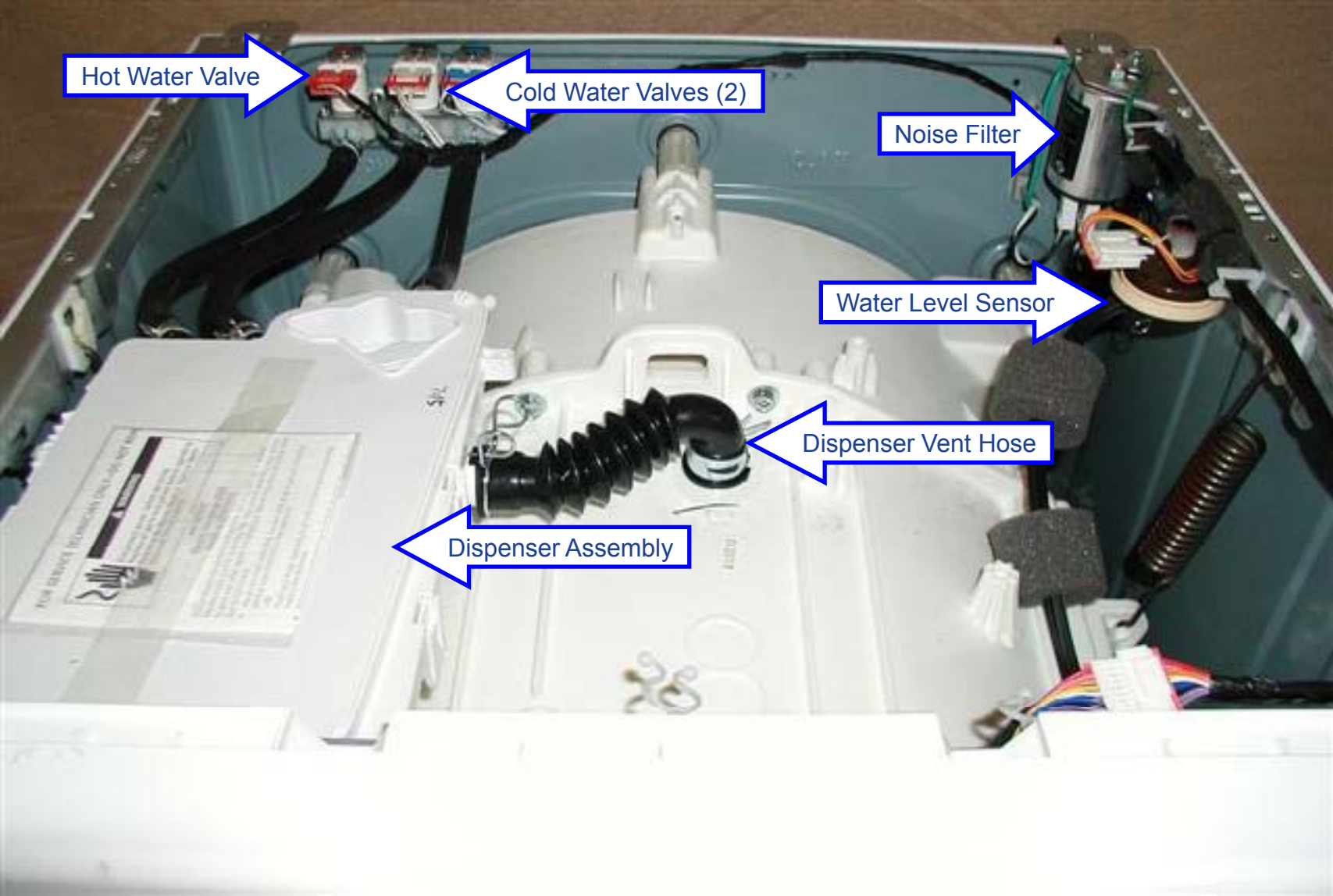

Water Valves

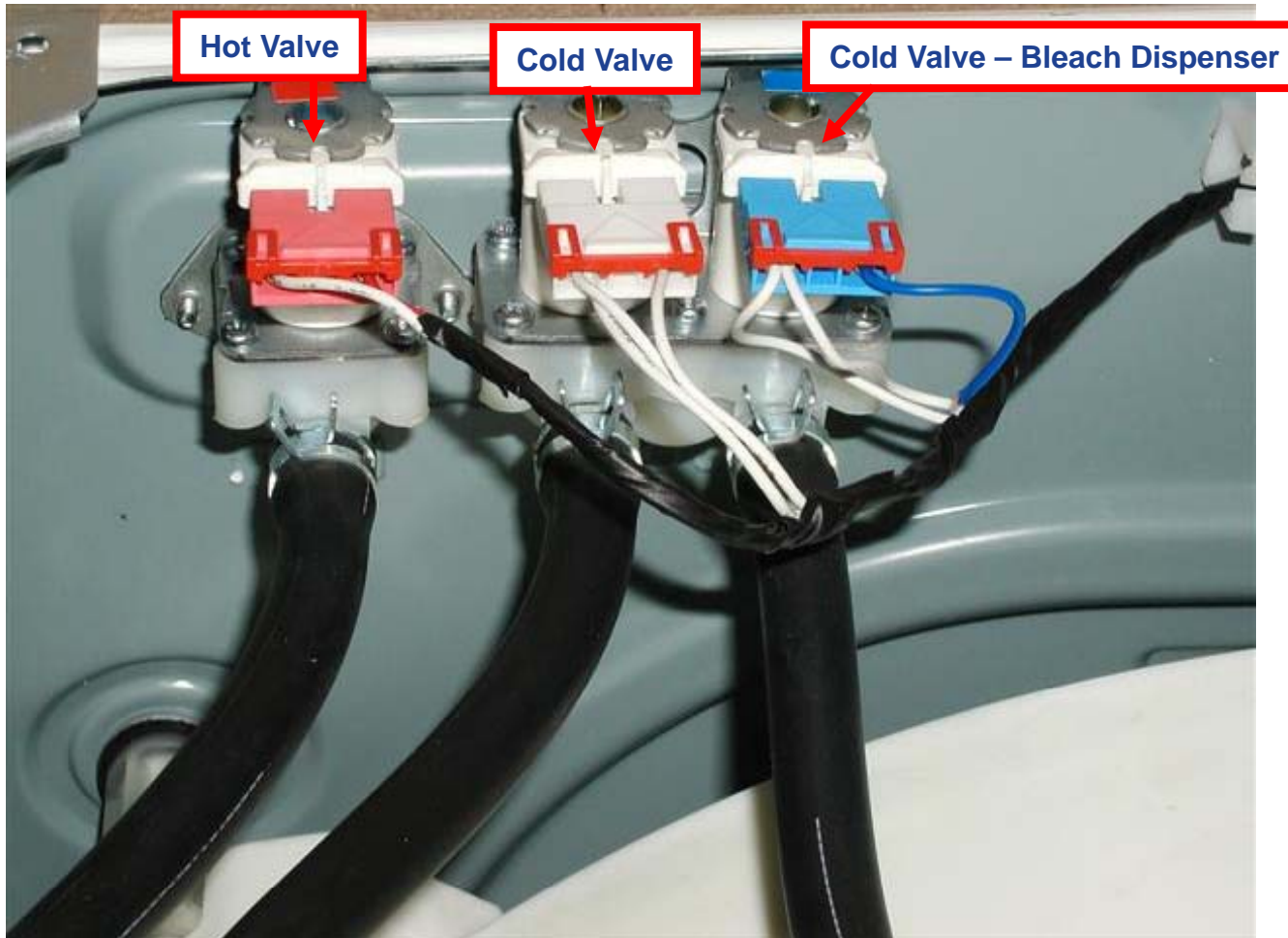

Flow Rates:

- Hot & Cold Valves --- 2.6 gal/min.
- Bleach Valve --- 1.1 gal/min.

Water Valves



- Hot water valve is a single valve and the cold water is a double valve assembly.
- Secured to the rear of the machine with Phillips screws.

Water Temperature Selections

Temperature	Temperature Setting
Tap Cold	No control
Cold	60°F +/- 5°F
Warm	90°F +/- 5°F
Hot	110°F +/- 5°F
Sanitize	153°F +/- 5°F

- Water temperature selections and approximate corresponding temperatures.
- Temperatures are maintained by thermistor feedback to main control board and by the control activating the appropriate water valve.

Water Level Sensor

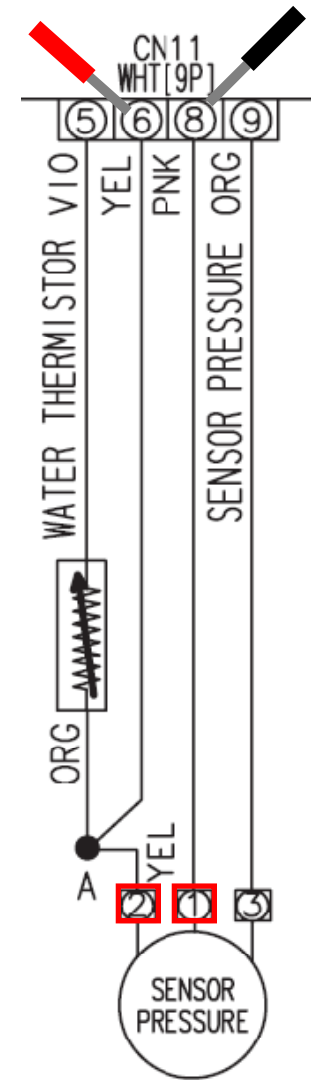

- Sensor frequency can be read at the pink & Yellow wires to the sensor (pins 1 & 2).

OR

- The control will read out frequency on the display in the t05 test.

Water Level Sensor

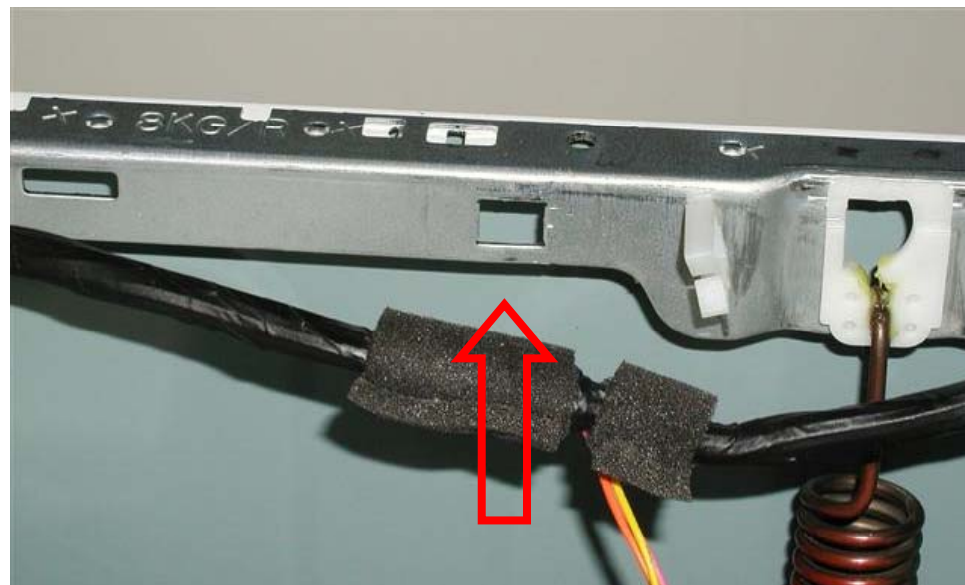
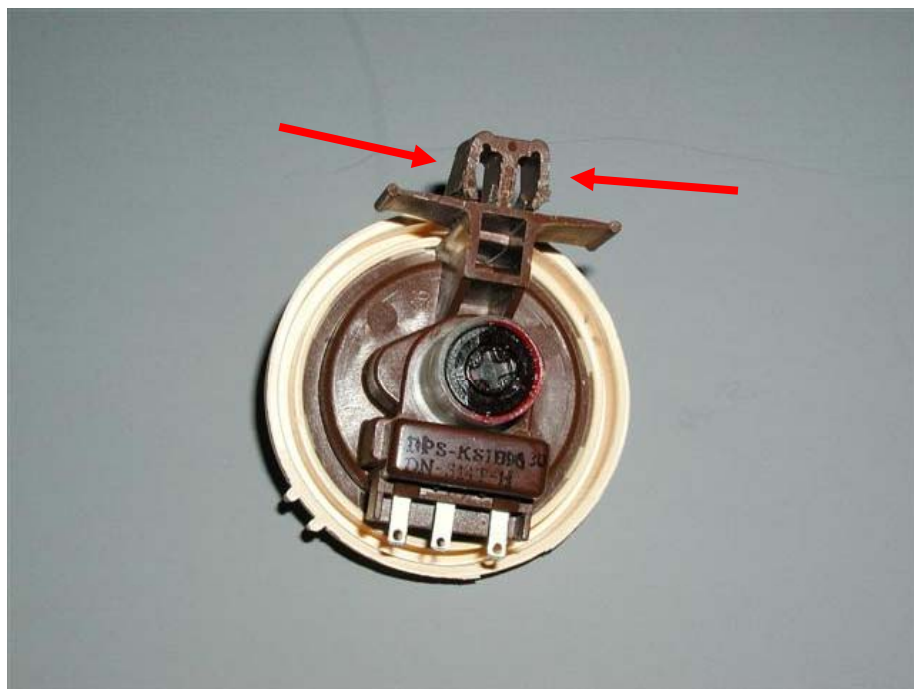

- To remove sensor, reach up behind frame with a pair of needle nose pliers and squeeze two tabs holding sensor behind frame opening.

Water Level Sensor

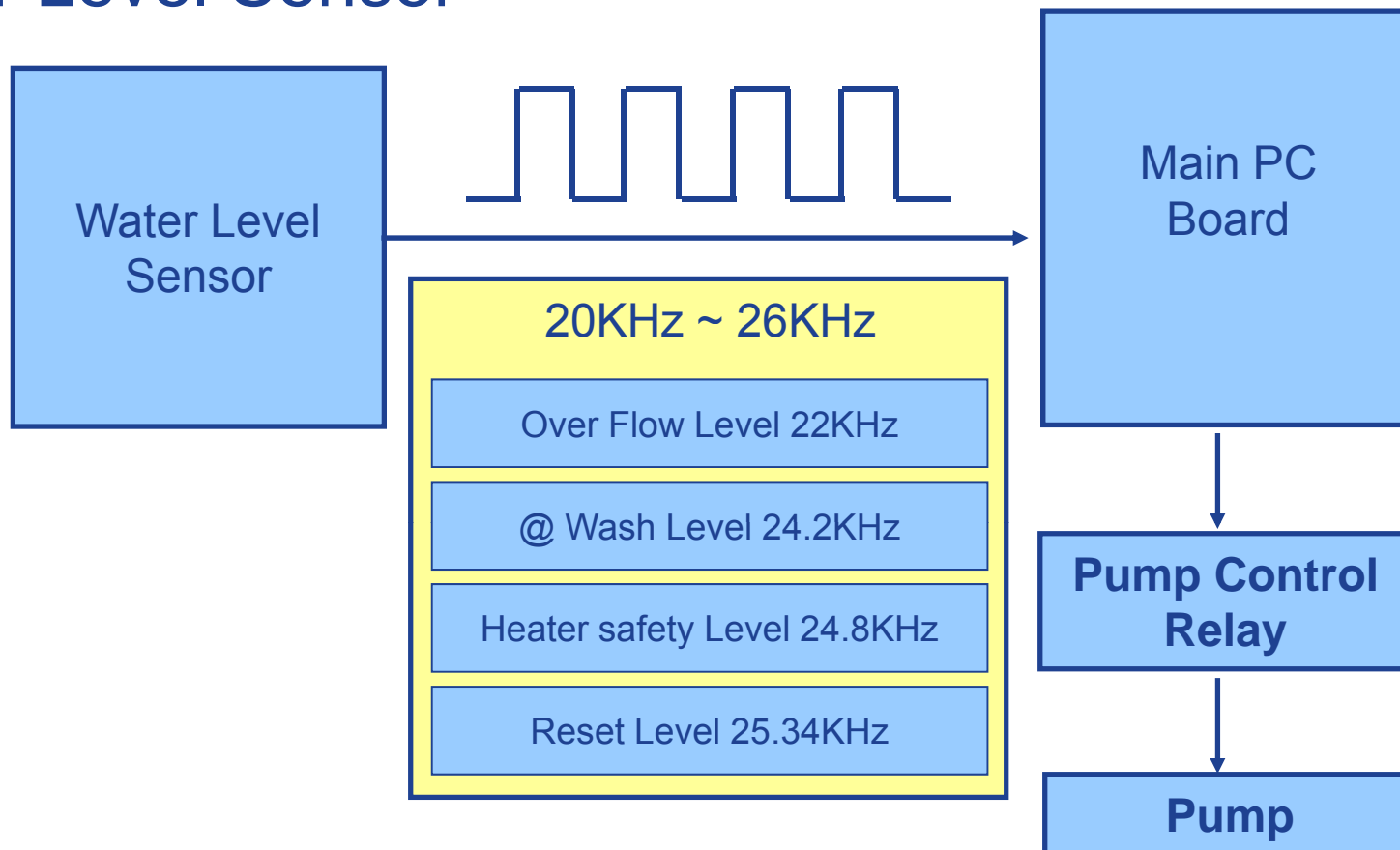

- Sensor frequency will vary depending upon water level.
- Drain pump will be activated when main PC board detects frequency under 22KHz. **(Flood Protection)**
- In **flood protection mode**, pump will run until reset level is reached.
- **Flood protection** is active even in the idle mode, as long as door is closed.

Water Level Sensor – Approximate Water Levels

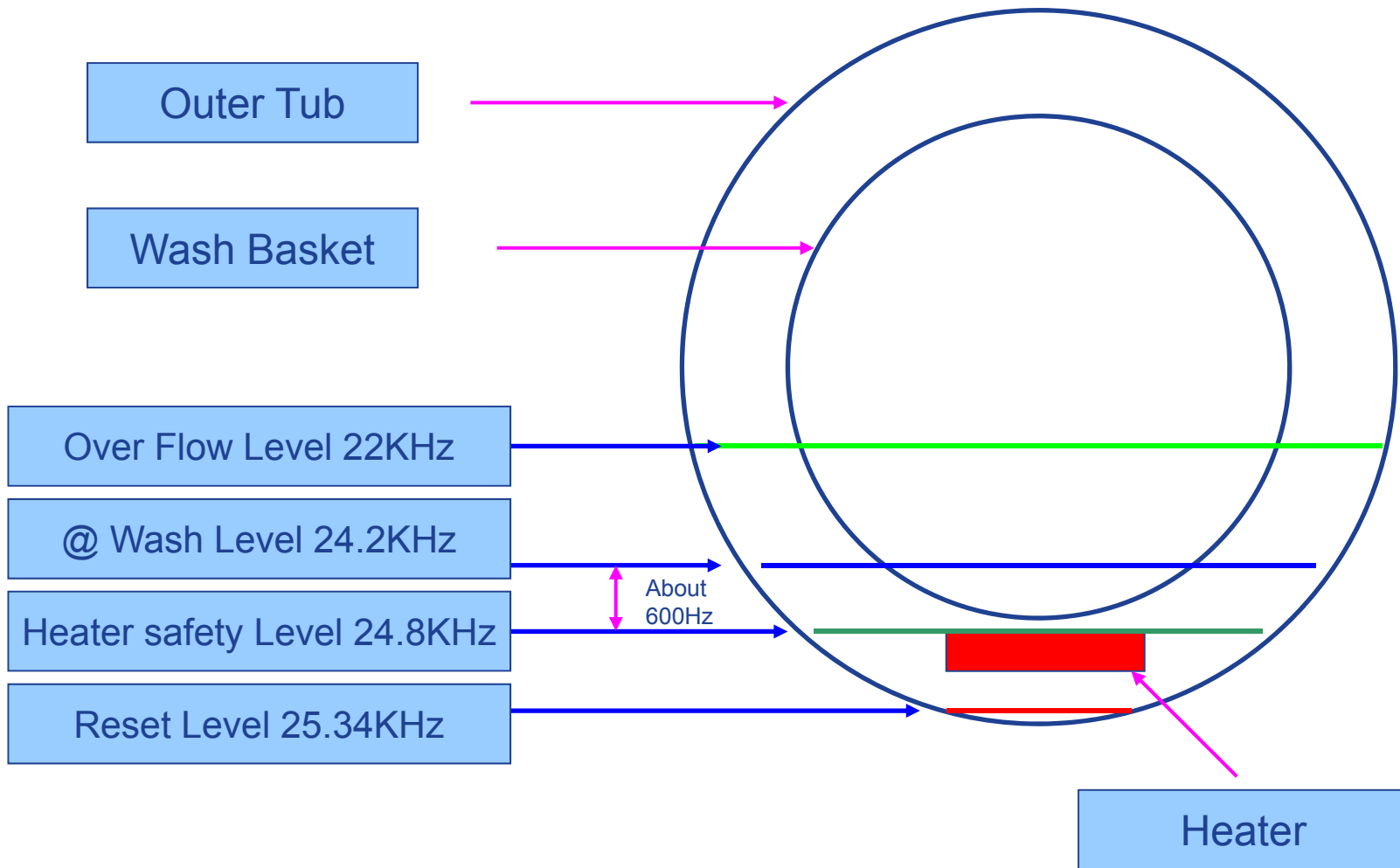

Noise Filter

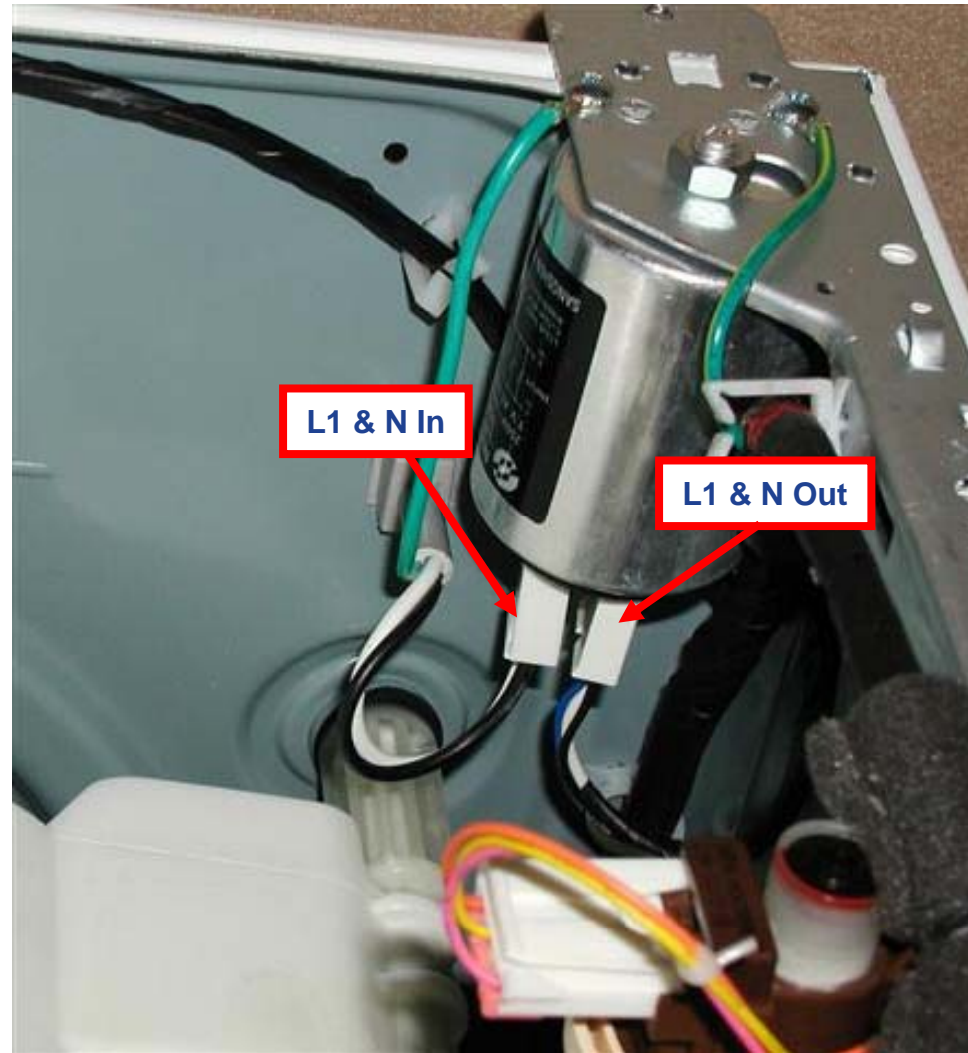

- The noise filter is held to the right, rear corner of the frame with a bolt and a threaded shaft.

Drain Pump Clean Out



- Pry open pump access door on front of washer to access the pump drain hose and filter assembly.

Drain Pump Clean Out



- Rotate hose cap approximately $\frac{1}{4}$ turn counter-clockwise to release cap from frame.
- Pull hose out and extend about 6 inches.

Drain Pump Clean Out



- Have the appropriate container at the ready.
- Pull cap from drain hose.
- Allow water to drain from the pump before opening filter assembly.

Drain Pump Clean Out



- Unscrew filter assembly from pump and clean debris as needed.

Drain Pump



To remove drain pump:

- Remove washer top, control panel and washer front.
- Drain water from pump assembly.
- Remove single Phillips screw securing pump to washer front frame.
- Push pump back through opening in frame.

Drain Pump

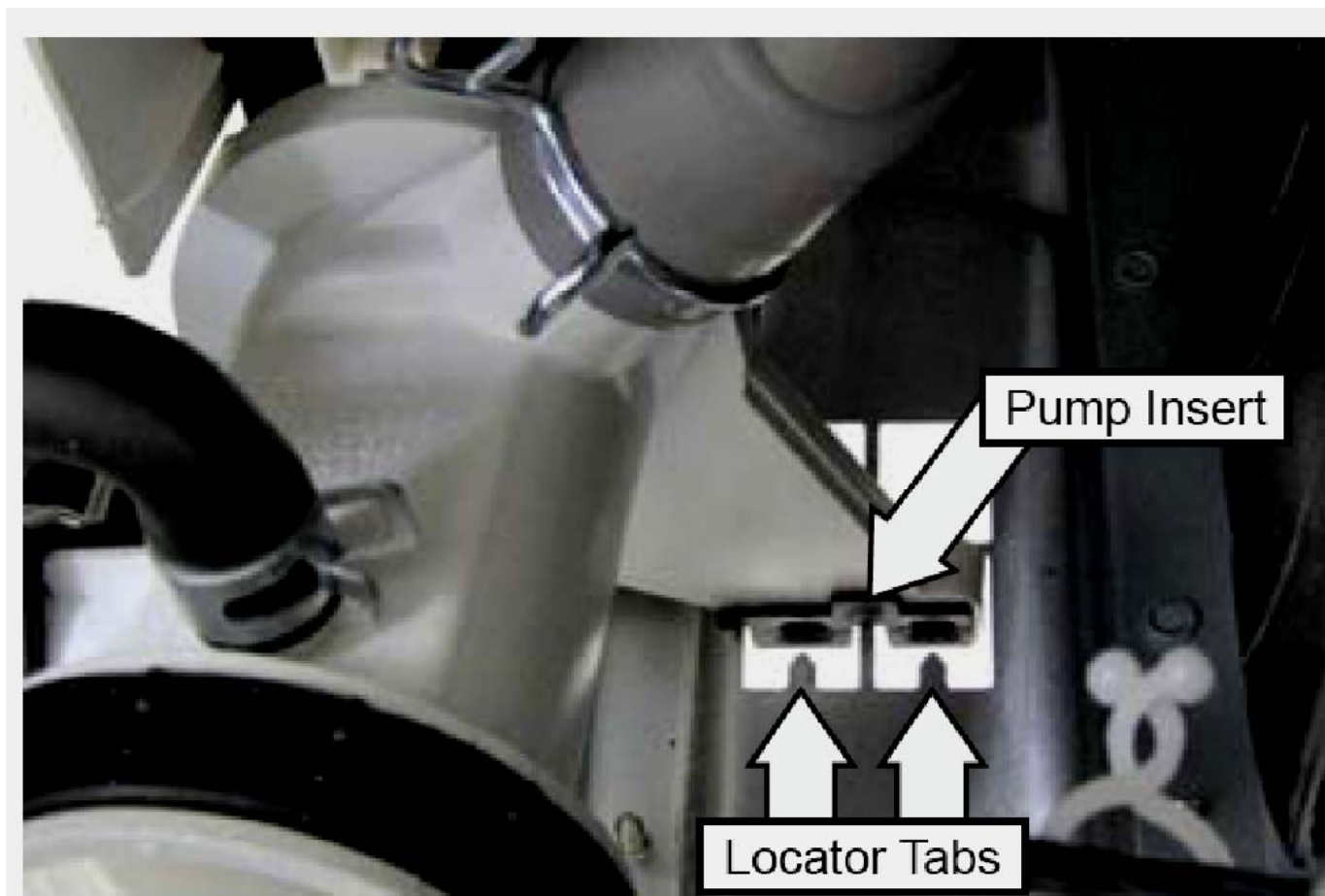

- Lift rear of pump to disengage locator tabs at bottom of washer.

Drain Pump

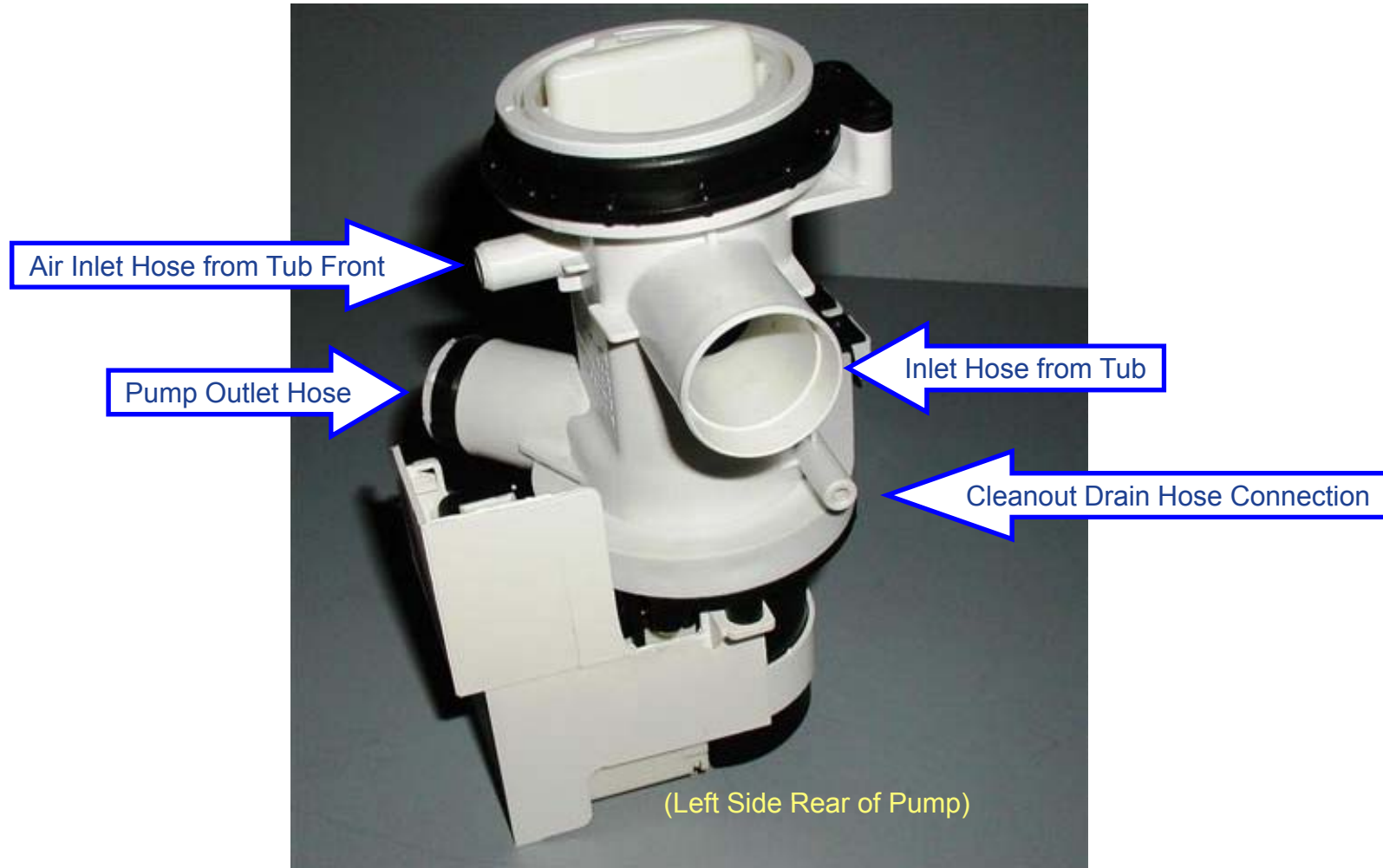

- Remove the four hoses connected to pump & lift out from washer frame.
NOTE: Air inlet port helps reduce cavitations noise.

Drain Pump



NOTE: Pump outlet port incorporates a check / one way valve to prevent drain water from re-entering pump from drain hose or house drain system.

Control Panel



To remove control panel assembly from washer:

- After lifting off washer top, remove 2 Phillips screws securing panel at the top of the frame.
- Disconnect single connector to main PCB board.

Control Panel



- Next, remove 2 Phillips screws from behind dispenser drawer.
- Lift panel assembly from washer.

Control Panel

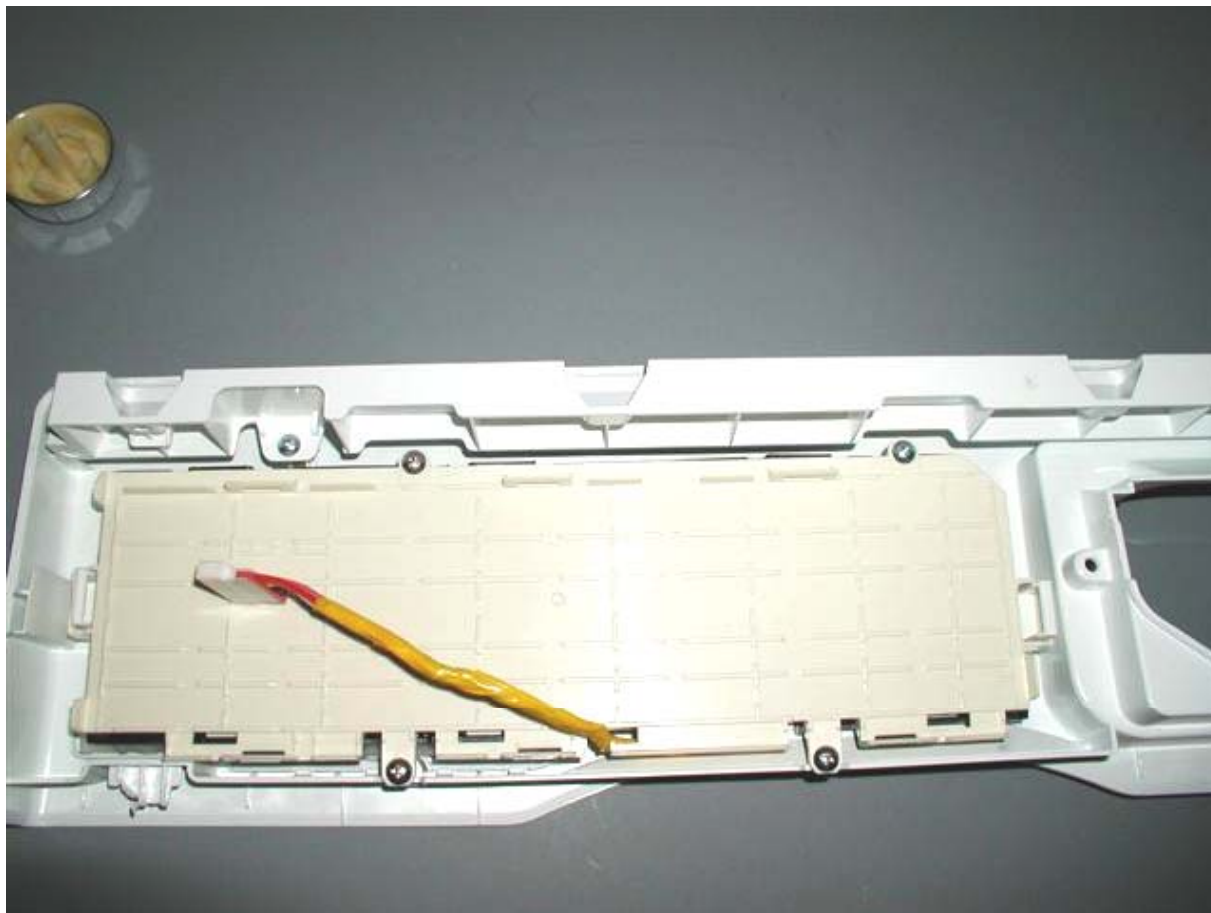

To separate control board from housing assembly:

- Pull off knob & remove 4 Phillips screws securing board to housing.
- Lift control board from plastic housing.

Control Panel



- Interconnect Cable comes with the control board when ordered or can be ordered as a separate component.

Door

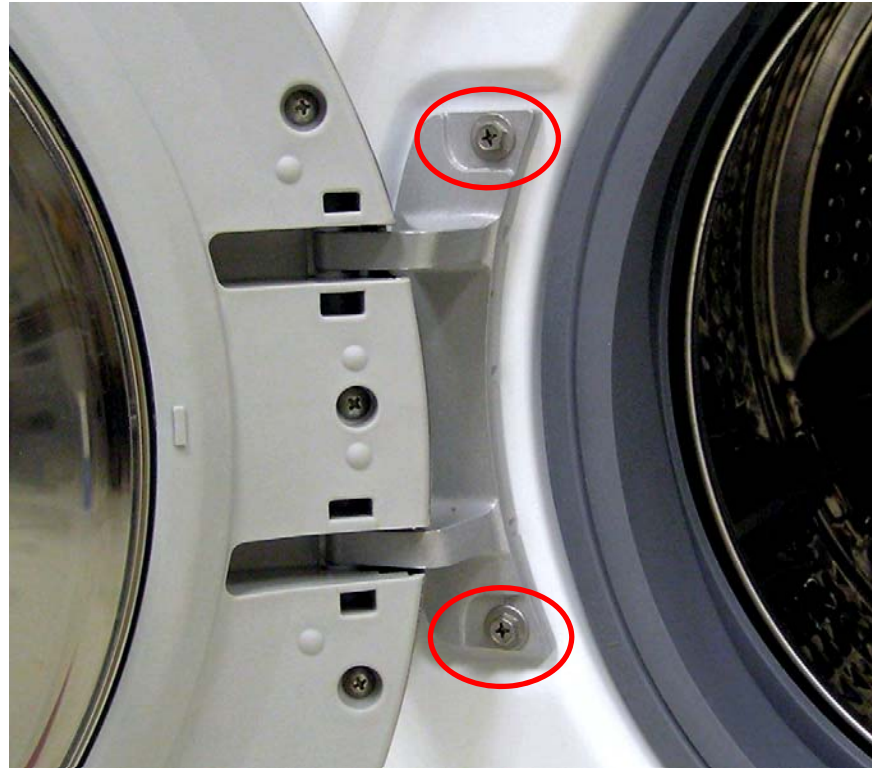

The door hinge is attached to the front panel with 2 Phillips screws and 3 hooks that engage 3 cutouts in the front panel.

To remove the door components:

- Remove the 2 Phillips screws that hold the hinge to the front panel.
- Grasp the door and lift the hinge 1/4" to disengage it from the front panel.
- Door can be further disassembled into individual components.

Door Lock Assembly

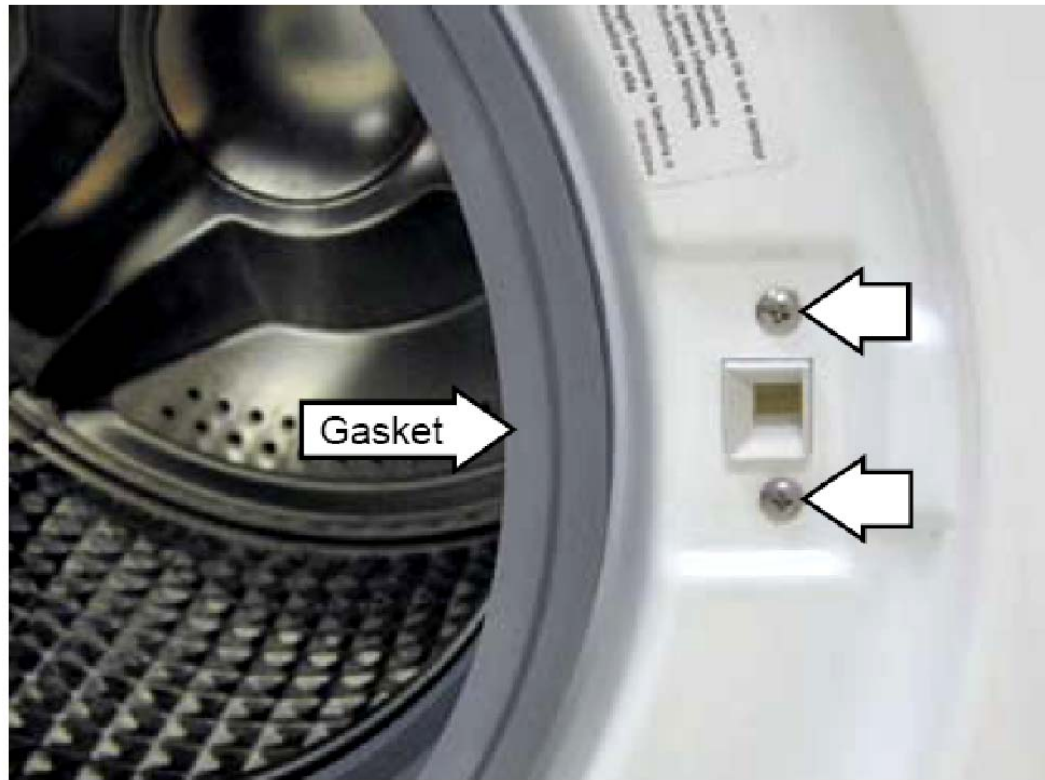

- The door lock assembly is held to the front panel with 2 Phillips screws.
- The door lock is accessed from the front of the washer when the right side of the gasket is partially pulled back.

Door Lock Assembly



To remove the door lock assembly:

- Use long nosed pliers to grasp the wire loop at the spring location and expand it to clear the gasket.
- Remove the spring and wire from the gasket.

Door Lock Assembly

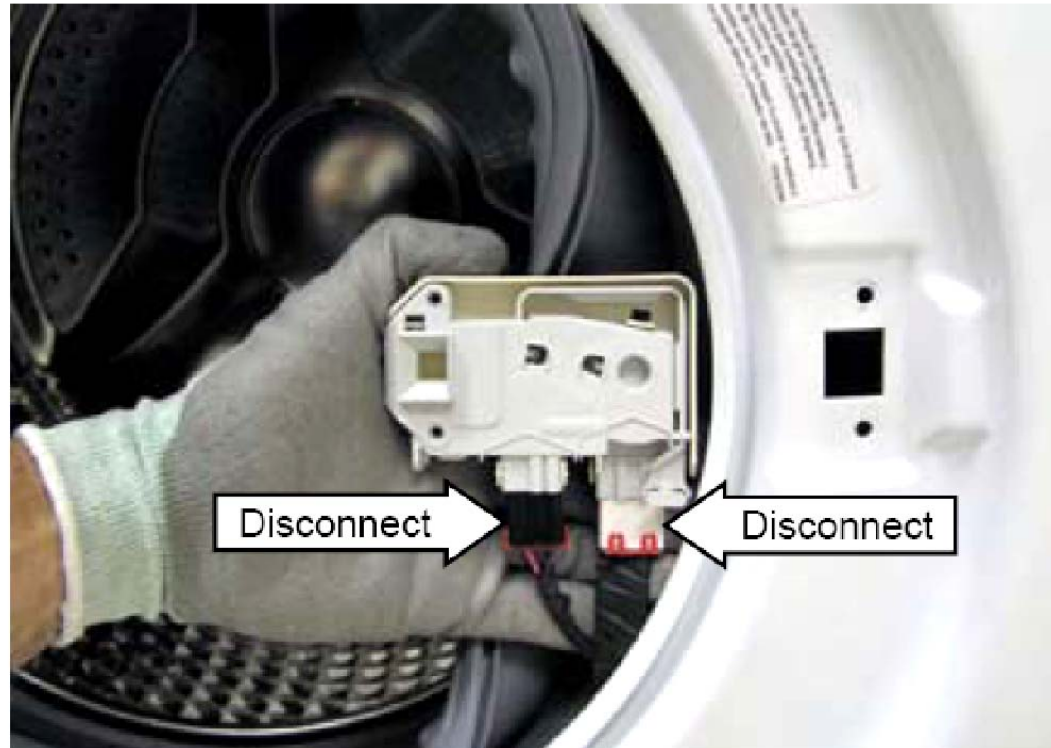

- Pull the right side of the gasket away from the front panel.
- Remove the 2 Phillips screws that hold the door lock to the front panel.
- Pull the door lock to the opening and disconnect the 2 wire harnesses.

Door Lock Assembly

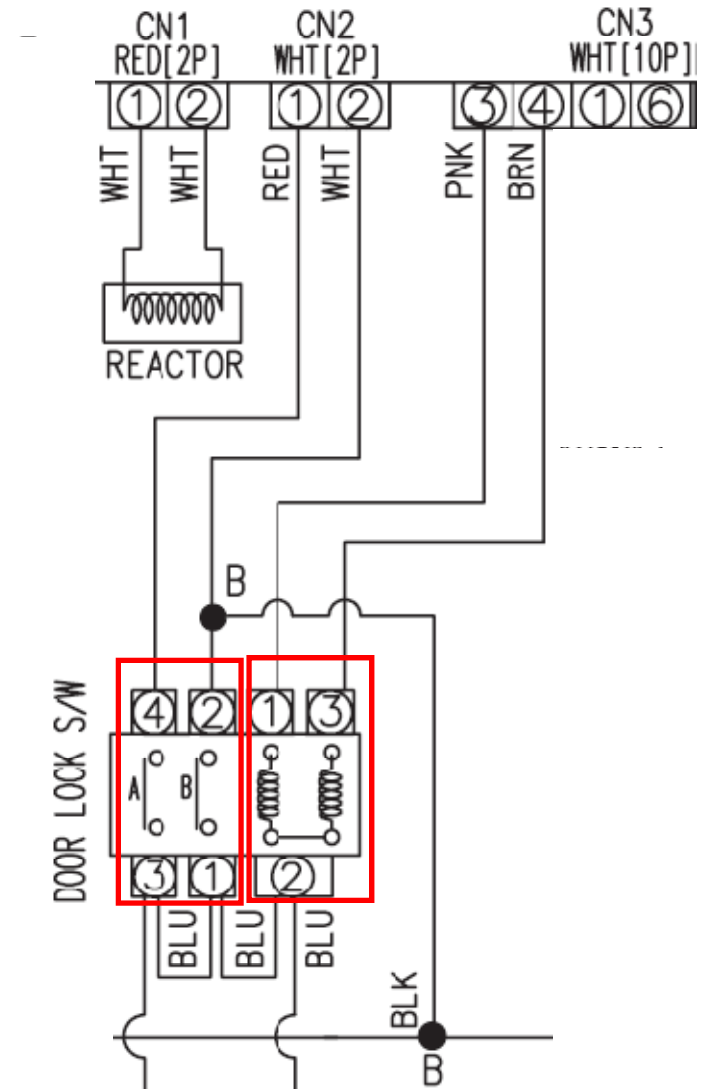
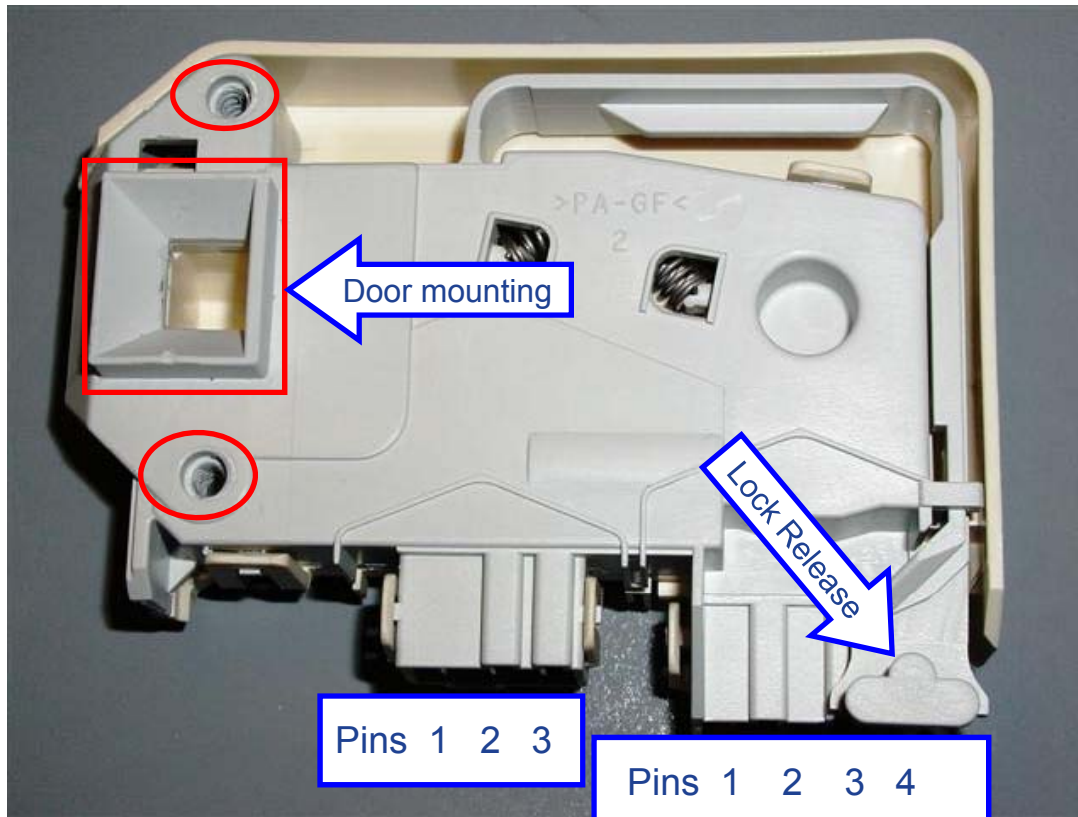

- Switch "A" (Pins 3 & 4) is closed when the door is closed.
- **Cycle will not start should this not occur.**

Door Lock Release

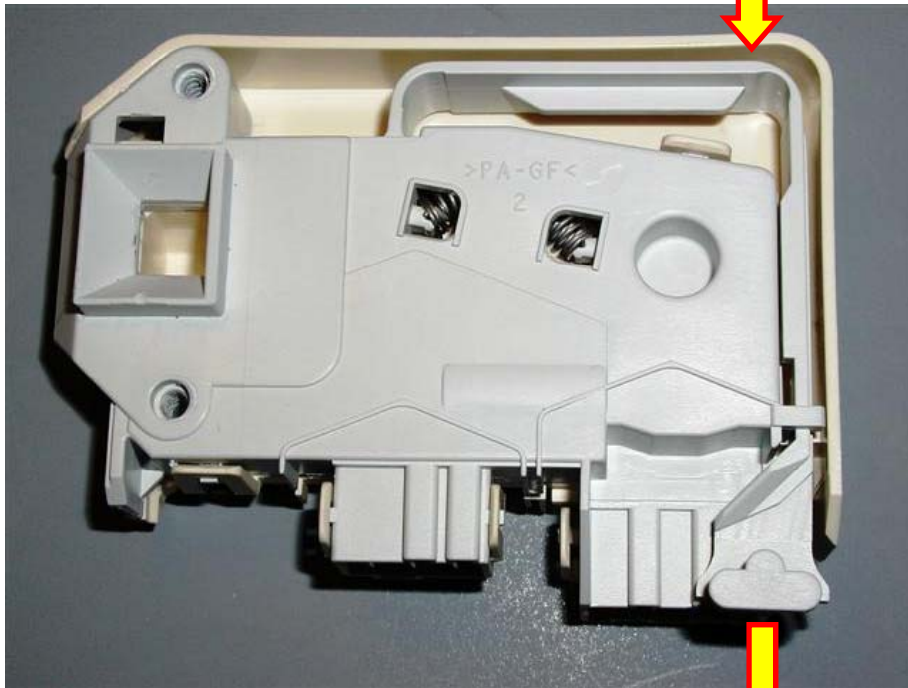

- To release door should a system failure occur:
- Remove washer top, remove control panel, remove two Phillips screws securing top of front panel & pull front panel a few inches outward at top.
- Reach down from the top with the back of your hand against the front panel.
- With you index finger between the front panel and lock mechanism, push down on the horizontal part of the lock release as you pull open the door.

Door Sensing Switch



- The door sensing switch provides feedback to the main control board as to the status of the washer door.
- **If the switch fails to close, cycle will not start.**

Door Sensing Switch Removal

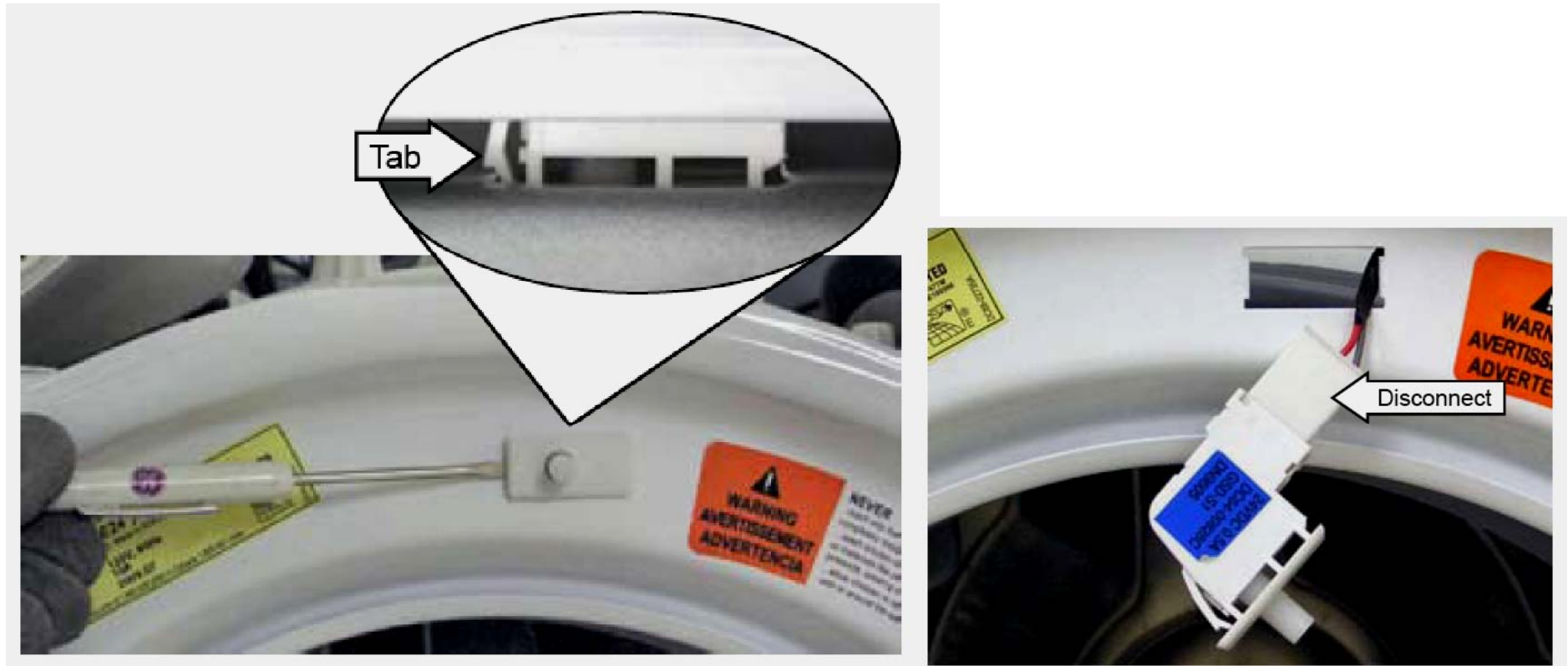

To remove the door sensing switch:

- Open the door.
- Using a small flat blade screwdriver, carefully pry out the left side of the switch to locate the locking tab.
- Press the locking tab in and pull the switch from the front panel.
- Disconnect the switch wire harness.

Rear Cover

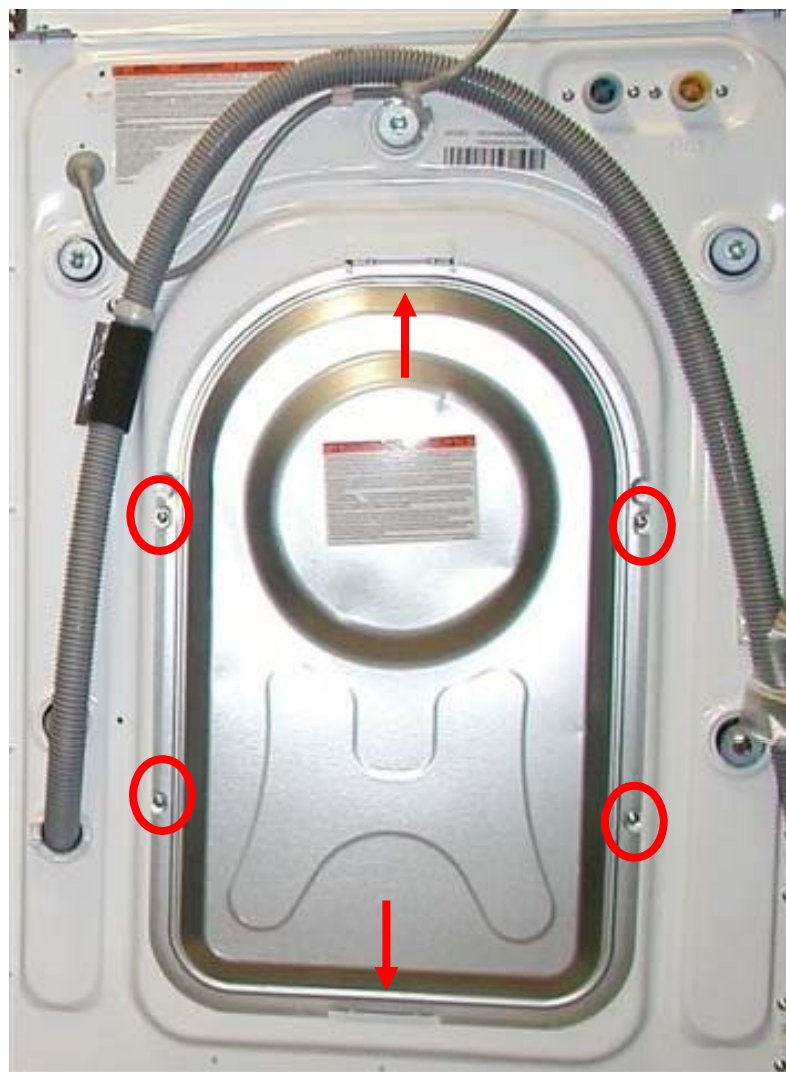

- To remove rear cover, first take out four Phillips screws.
- Then flex cover top to bottom to release from tabs.

Rear Component View

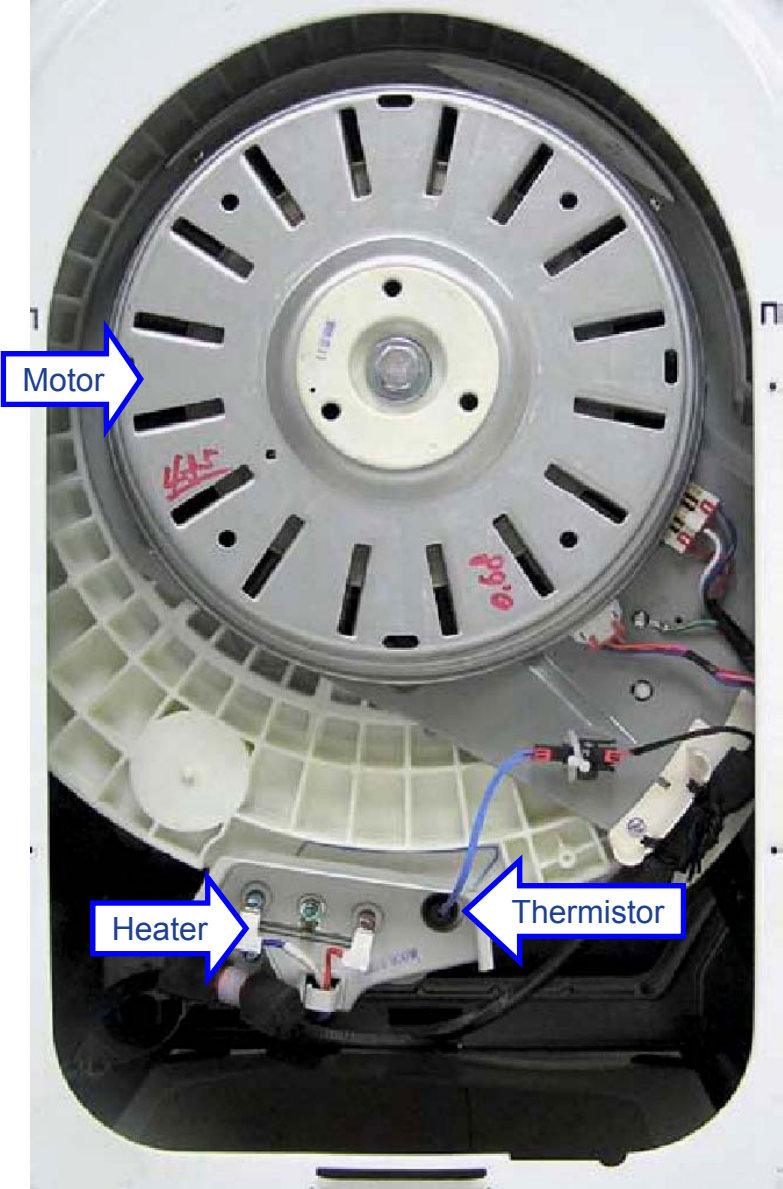

Motor Assembly

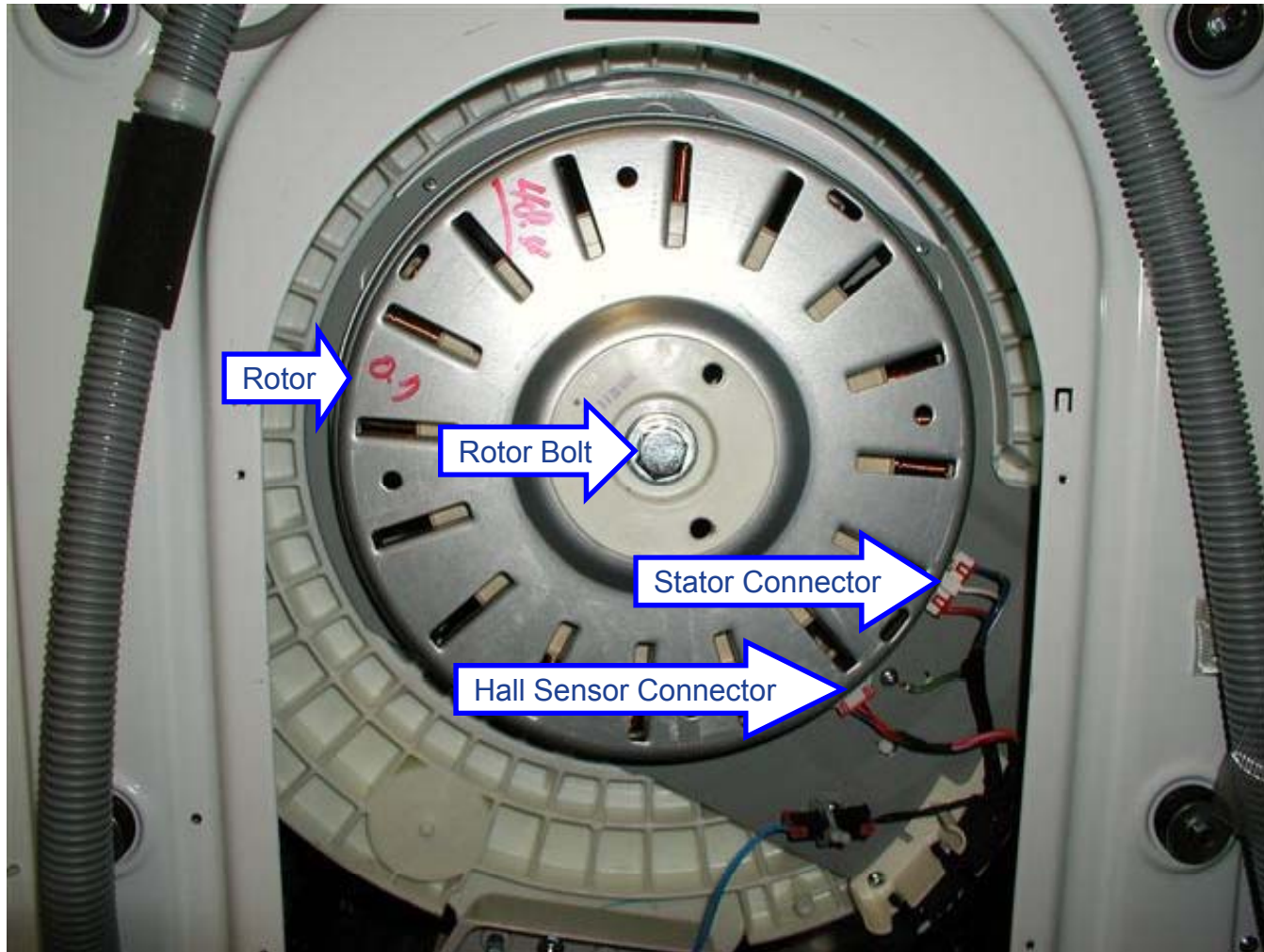

WARNING: The rotor is not grounded. Unplug the washer before servicing to avoid electrical shock.

Rotor Bolt



- Remove the rotor Bolt using a 19mm (WX05X15000) socket and socket wrench or impact gun.
- **Note:** Use a rubber mallet, if needed, to tap the wrench to break the bolt free.
- Pull the rotor away from the drive shaft.
- **When re-tightening bolt should be snug + a quarter turn.**

Rotor Bolt

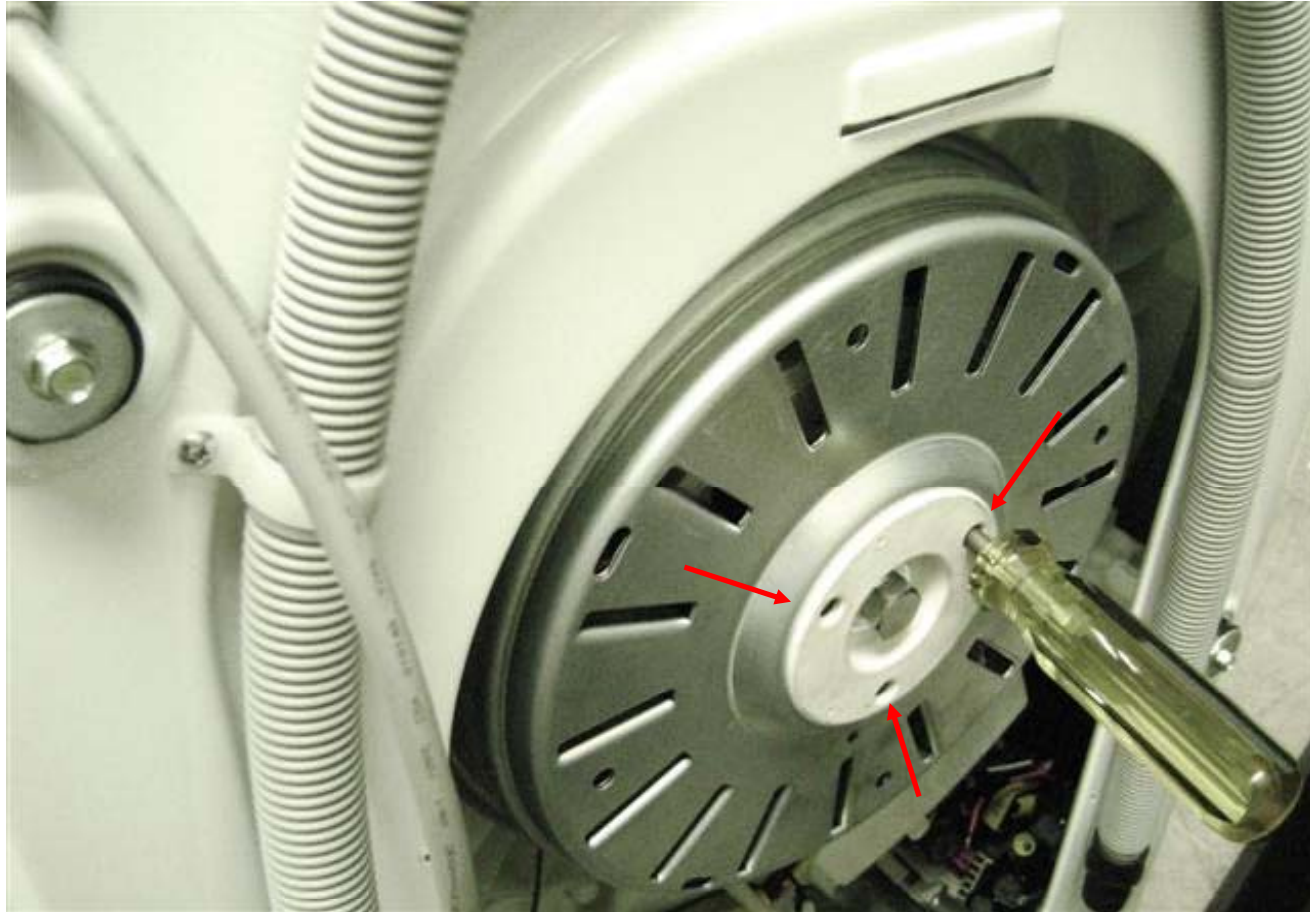

If necessary, to lock the rotor in place while removing rotor bolt, utilize a large Phillips screwdriver inserted into one of the three round openings as shown.

Motor Assembly

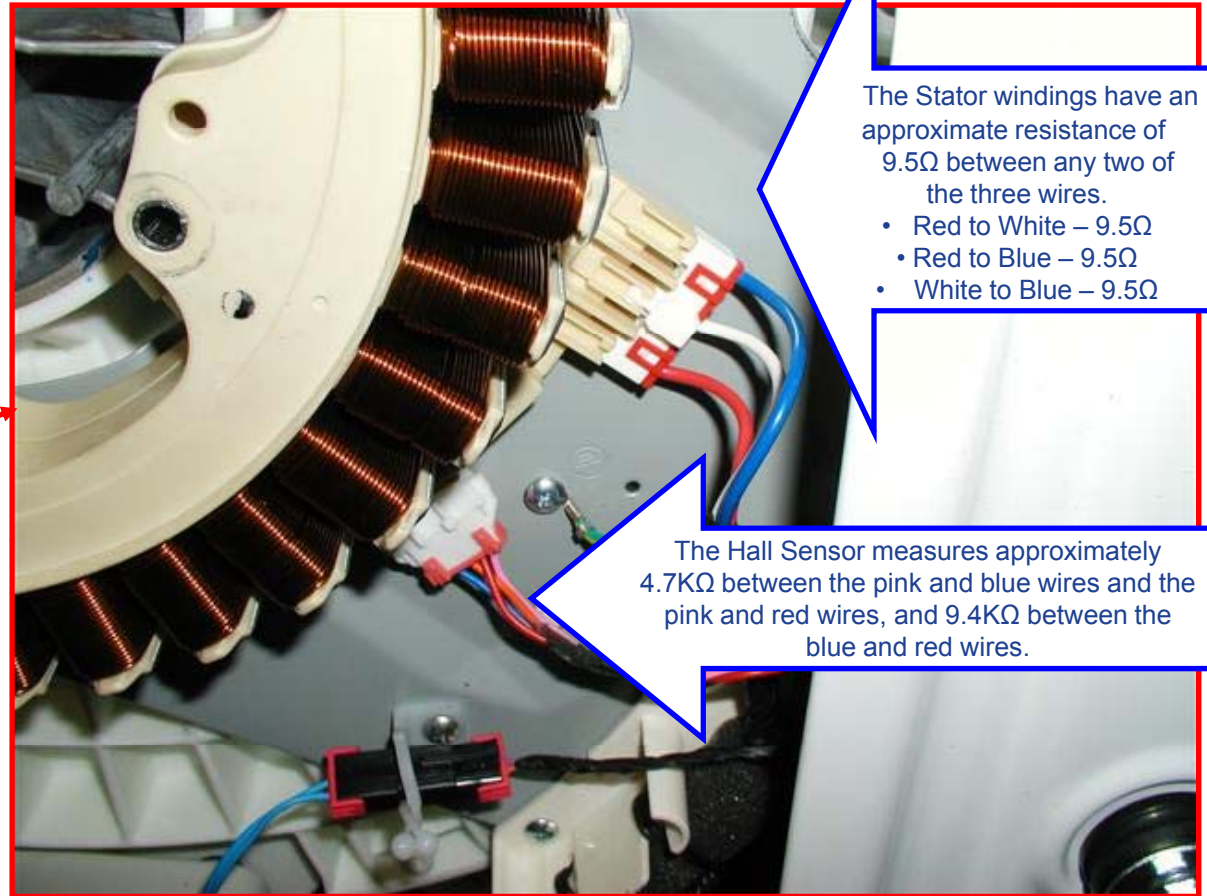
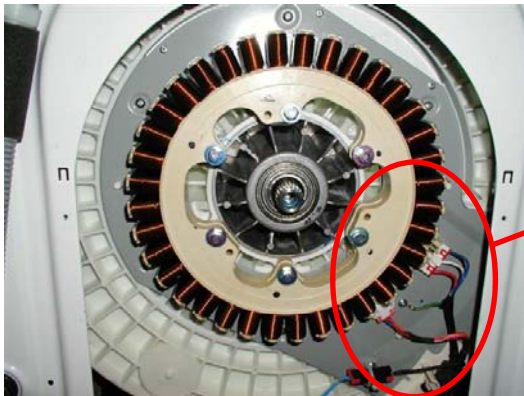

The Stator windings have an approximate resistance of 9.5Ω between any two of the three wires.

- Red to White – 9.5Ω
- Red to Blue – 9.5Ω
- White to Blue – 9.5Ω

The Hall Sensor measures approximately $4.7K\Omega$ between the pink and blue wires and the pink and red wires, and $9.4K\Omega$ between the blue and red wires.

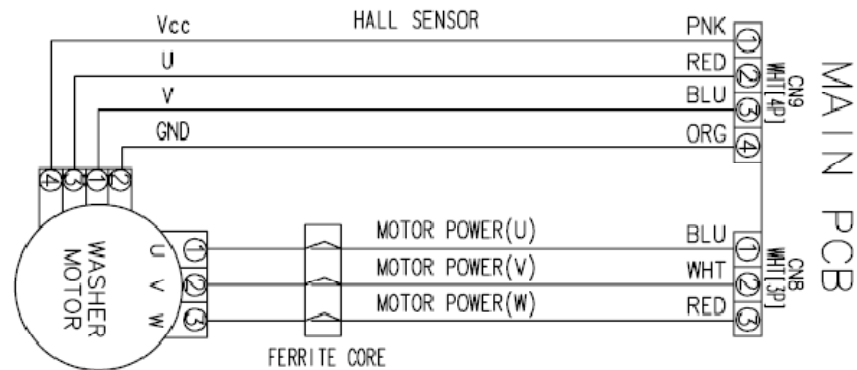

Motor Assembly

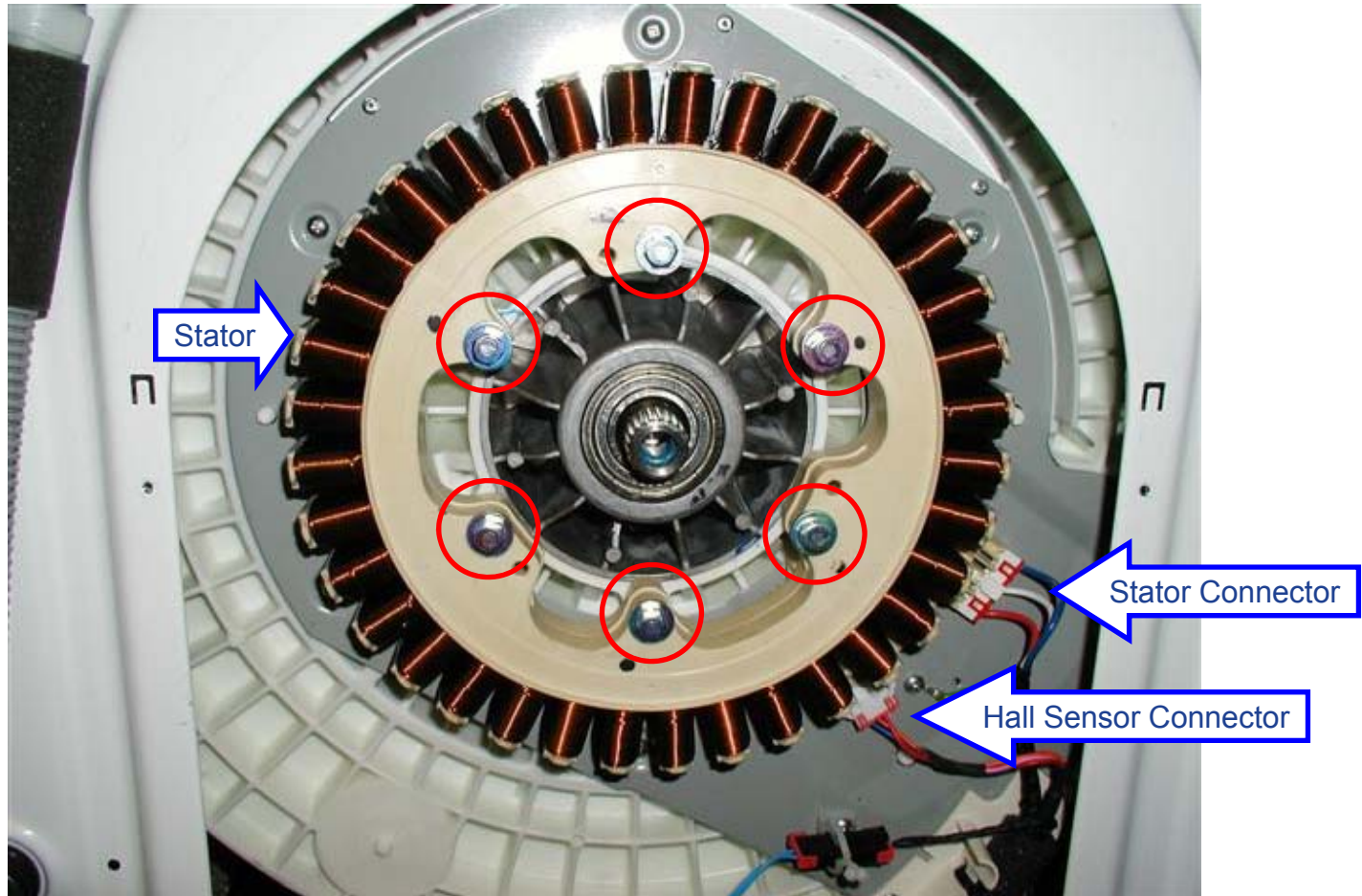

- To remove stator, start by removing wiring to stator and Hall Sensor.
- Remove the six 10-mm hex head screws and washers that hold the stator in place.
- Carefully pull the stator away from the outer tub.

Motor Assembly

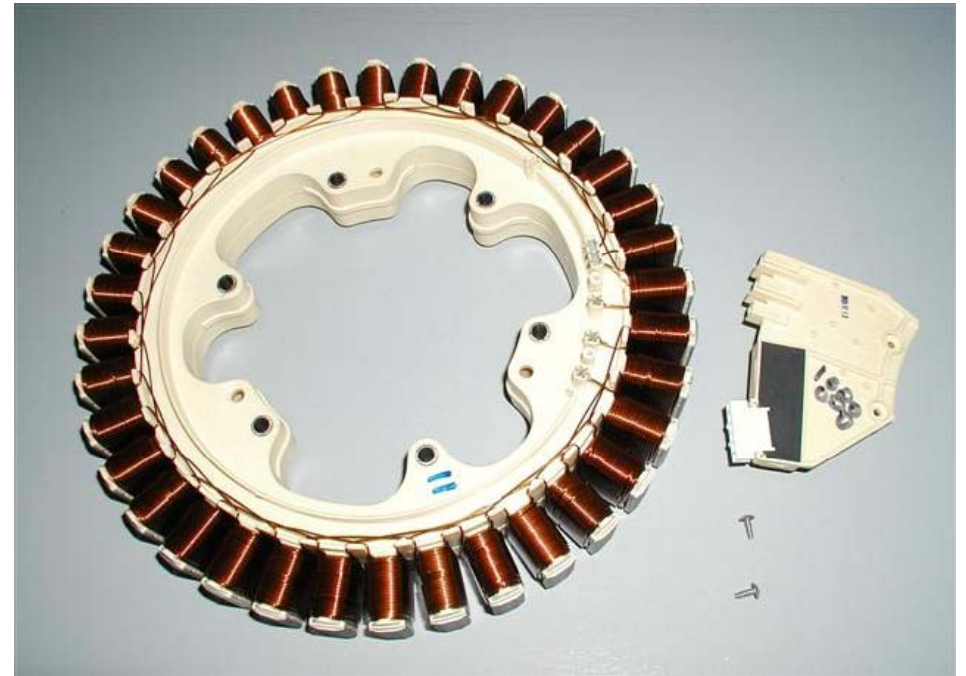
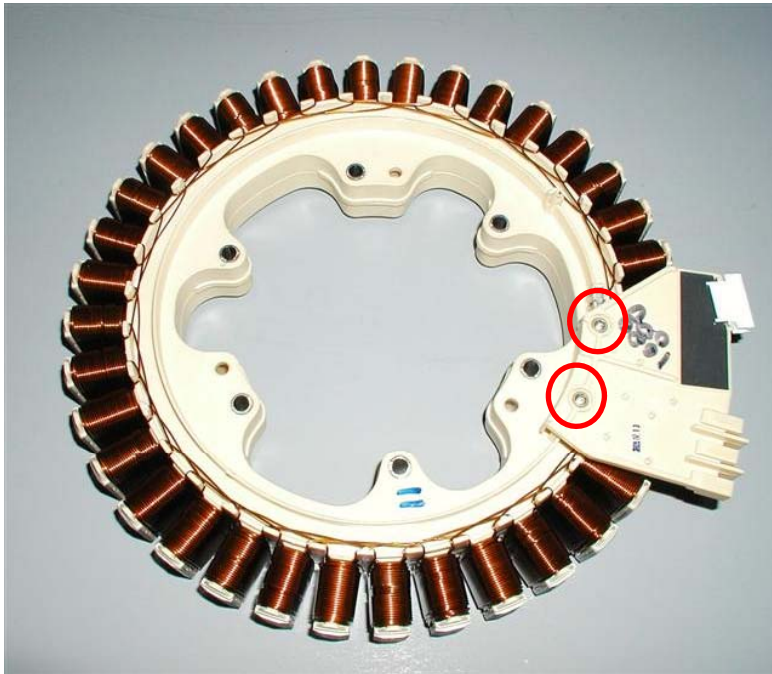

- Stator and Hall Sensor are separate components.
- To separate Sensor from the Stator, remove two small Phillips screws securing components.
- Pull Sensor straight up to disengage.

Motor Assembly / Hall Sensor

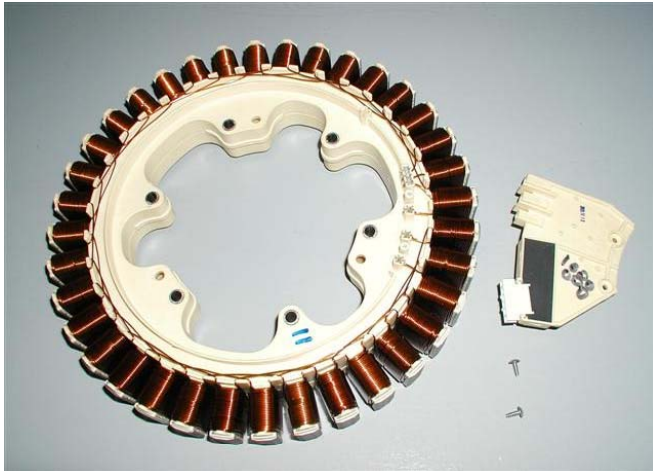

- The Hall effect sensor measures the motor rpm.
- The Hall sensor measures approximately 4.7K Ω between the pink and blue wires and the pink and red wires, and 9.4K Ω between the blue and red wires.
- If the sensor has failed, the motor will not operate.
- The Hall sensor is part of the stator assembly. It is also available as a separate part.

Motor Assembly

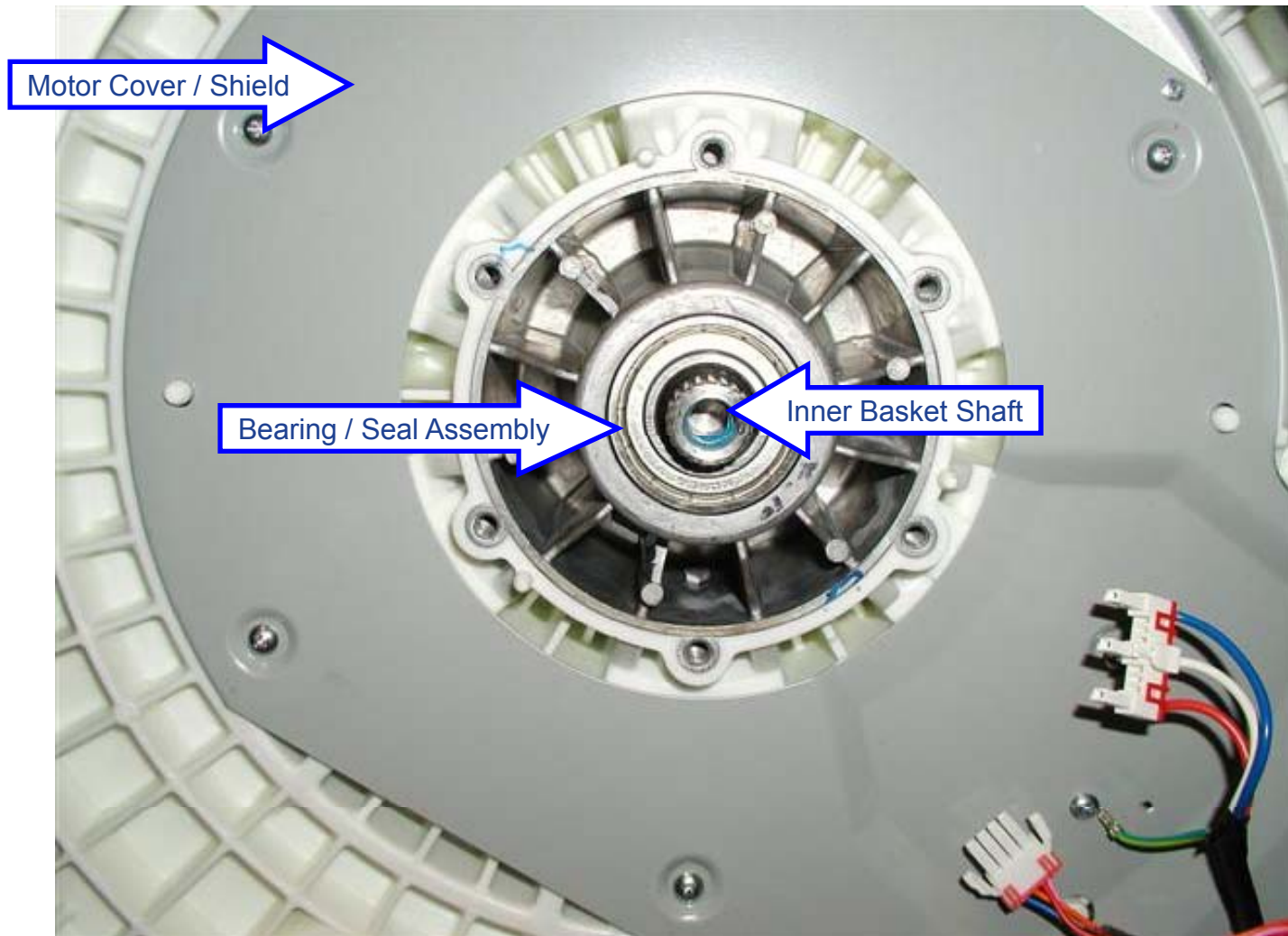

- Bearing / Seal Assembly comes as part of the lower outer tub assembly.

Front Panel



- The front panel is hung on 3 hooks attached to the bottom of the cabinet and held in place with 4 Phillips-head screws.
- The door lock and door sensing switch are attached to the front panel.
- The washer top and control panel must be removed in order to remove the front panel

Front Panel



Note: The following step will require raising the front of the washer approximately 2 inches. It may be helpful to use prop block WX05X10016), to safely raise the washer.

- Raise the front of the washer approximately 2 inches.
- Remove the 2 Phillips-head/10-mm hex-head screws (1 on each side), that attach the front panel to the right and left-side hooks.

Front Panel



- Remove washer top, control panel, wire harness from door sensing switch, wire and spring securing gasket to front panel and door lock switch from front panel.
- Remove two large Phillips screws securing front panel to frame.
- Lift front panel from 3 hooks at bottom and remove from washer.

Front Component View

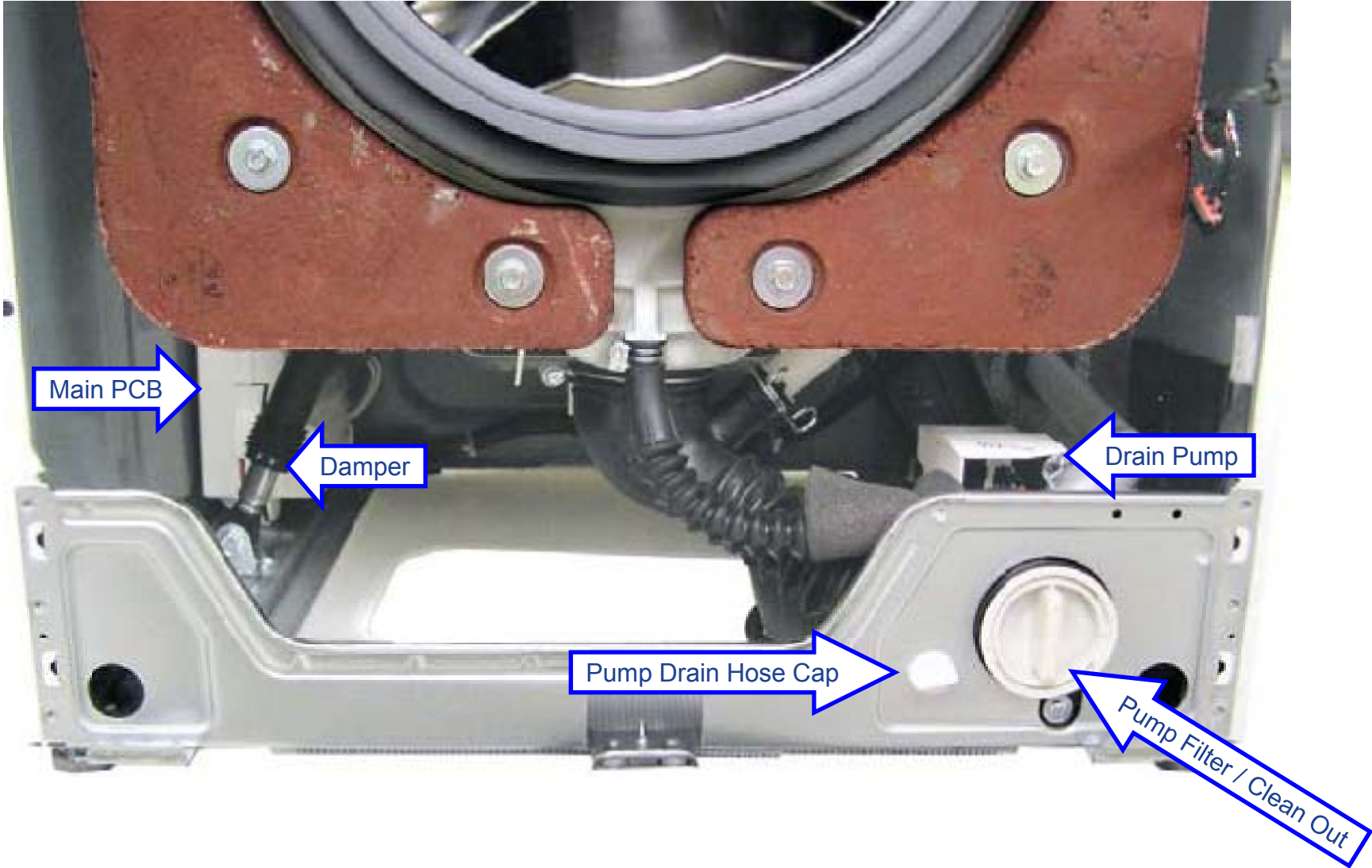

Damper Shock Assemblies



- Each of the two dampers are attached to the outer tub with a 10-mm hex head screw and secured to 2 flanges in the bottom of the cabinet with a 13-mm hex head bolt.

Heater Assembly

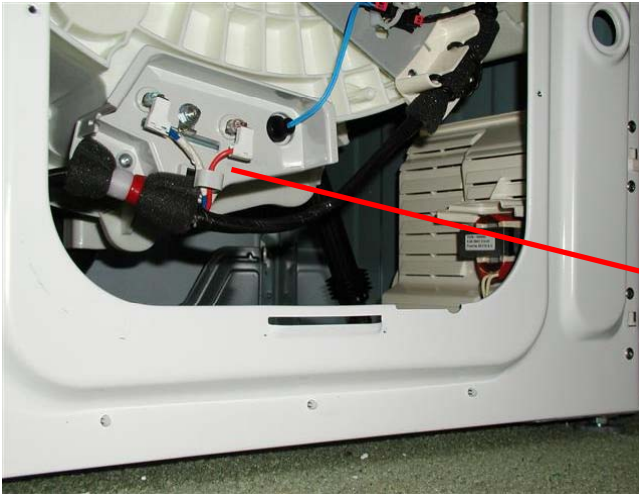

(Rear of Machine)



- The heater assembly is held in place by a bracket attached to the outside of the outer tub and a 10-mm nut which compresses a rubber gasket to the tub opening.
- When the 10-mm hex nut is tightened, it squeezes the rubber gasket between 2 mounting plates to seal the heater assembly to the opening of the tub.
- The hex nut is set from the factory at 35 - 40 in. lbs of torque.
- The wire terminal under hex nut is unused.

Heater Assembly



Heating Element Specifications:

- 120 VAC
- 900 Watts
- Approximately 7.5 Amps
- Approximately 16Ω

Heater Assembly Removal



- Loosen the 10-mm hex nut until it is flush with the end of the stud.
- Push inward on the 10-mm hex nut to relax the rubber gasket.
- Remove the 10-mm hex nut from the heater shield.
- Maneuver the heater shield from the heater terminals and remove thermistor wire harness from the hole in the shield.
- Grasp and pull the heater straight out from the outer tub.

Heater Algorithm

- Heater operation follows the algorithm to the right.
- Heater is operational only during the sanitize cycle.
- Timer does not pause to allow heater to heat the wash water to the sanitize temperature (@ 153° F).

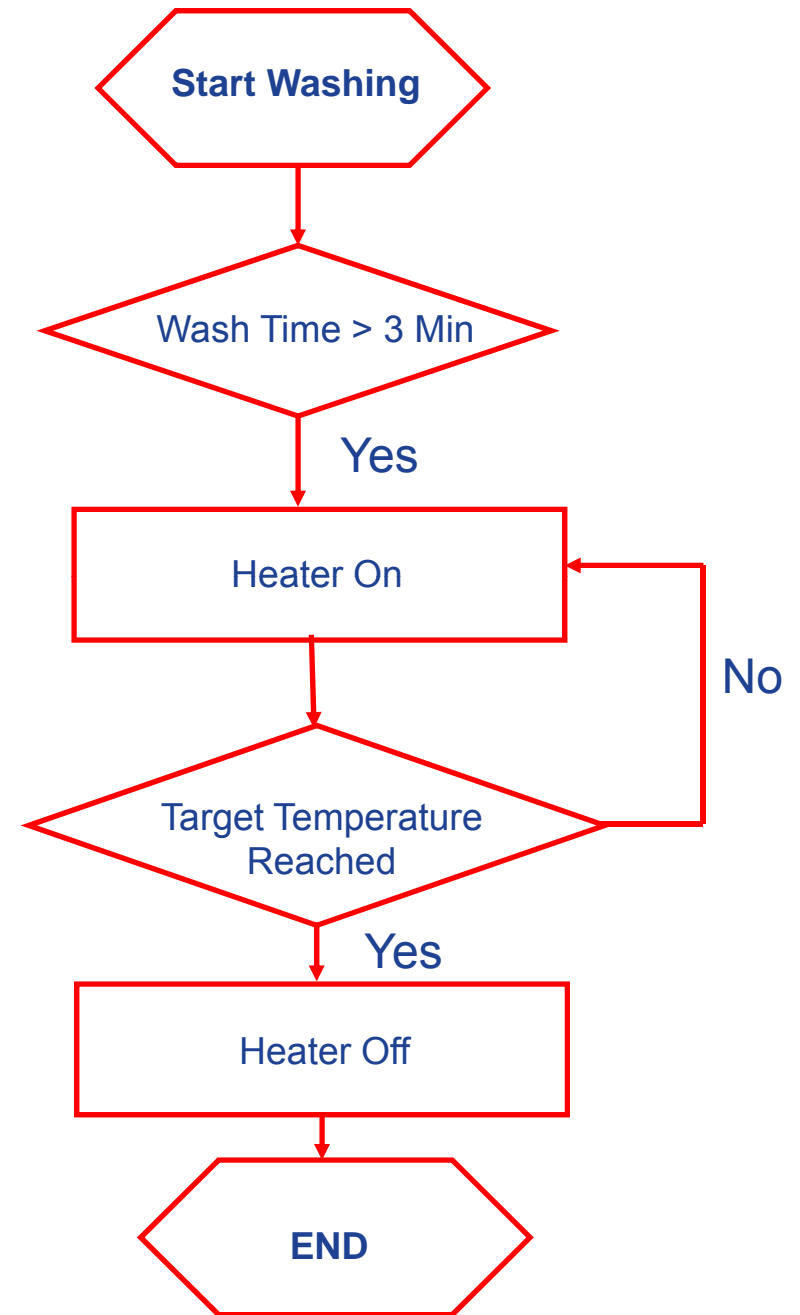

Thermistor

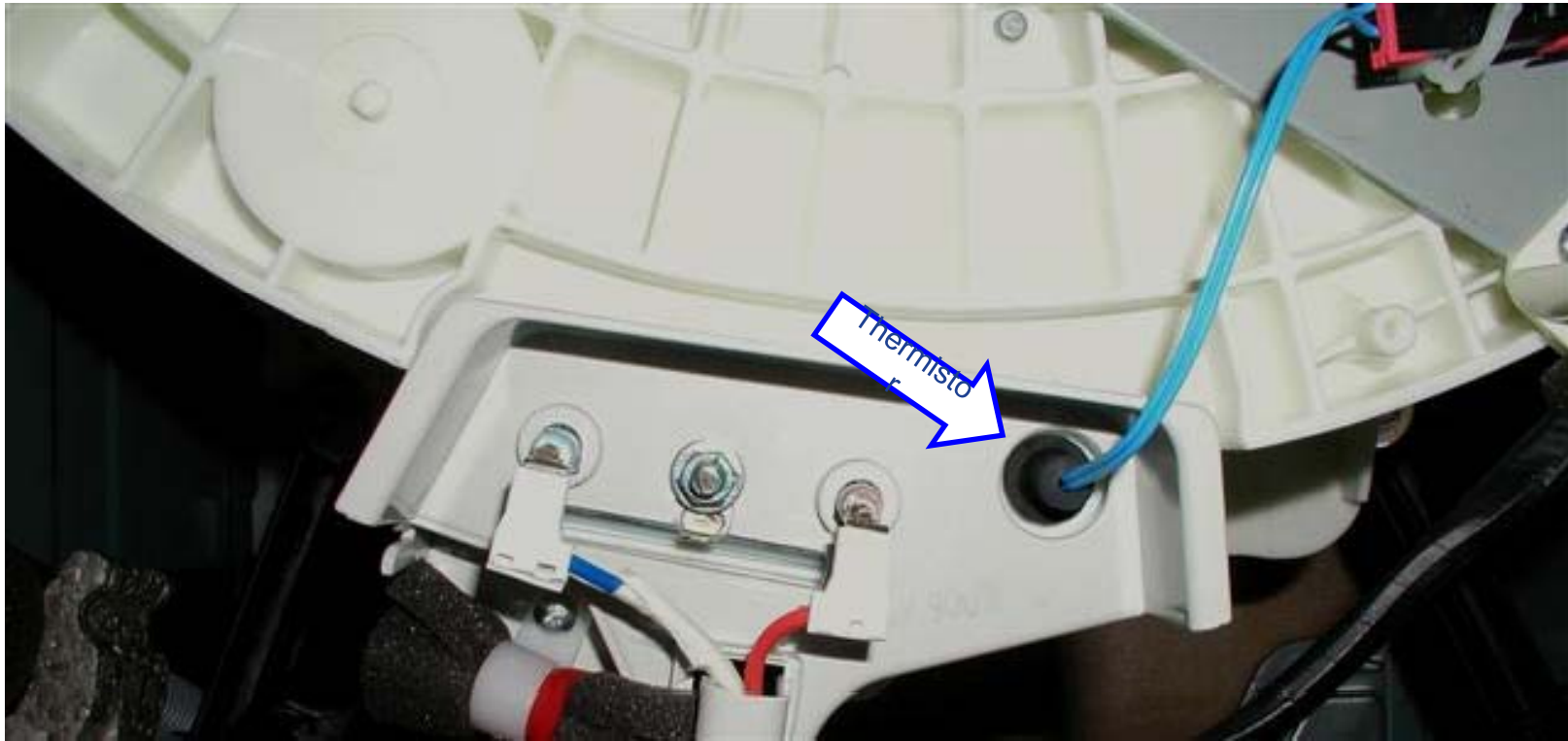

- The control uses a water temperature sensor (thermistor) to regulate the wash water temperature.
- The thermistor has a negative temperature coefficient (as temperature increases, resistance decreases).
- The thermistor is inserted in a grommet that is located below the motor, and is accessed from the rear of the washer.

Thermistor Testing



- Thermistor can be checked at it's disconnect plug for resistance.
- It should read approximately 14K Ω at room temperature.

Thermistor Removal



- To remove thermistor, disconnect the thermistor wiring harness.
- Grasp and pull the thermistor straight out from the grommet.
- Thermistor – WH12X10447 Grommet – WH01X10490

Thermistor Temperature / Resistance Chart

TEMP (°F)	MIN (KΩ)	AVG (KΩ)	MAX (KΩ)
14	54.874	58.722	62.57
23	42.961	45.778	48.596
32	33.9	35.975	38.05
41	26.977	28.516	30.055
50	21.616	22.763	23.91
59	17.421	18.279	19.137
68	14.128	14.772	15.417
77	11.497	11.981	12.464
86	9.421	9.786	10.15
95	7.772	8.047	8.322
104	6.444	6.653	6.861
113	5.365	5.523	5.68
122	4.489	4.608	4.726
131	3.767	3.856	3.945
140	3.178	3.243	3.308
149	2.681	2.744	2.808
158	2.273	2.332	2.392
167	1.934	1.99	2.045
176	1.653	1.704	1.755
185	1.416	1.464	1.511
194	1.218	1.262	1.305
203	1.053	1.093	1.133
212	0.913	0.95	0.987

Main PC Board

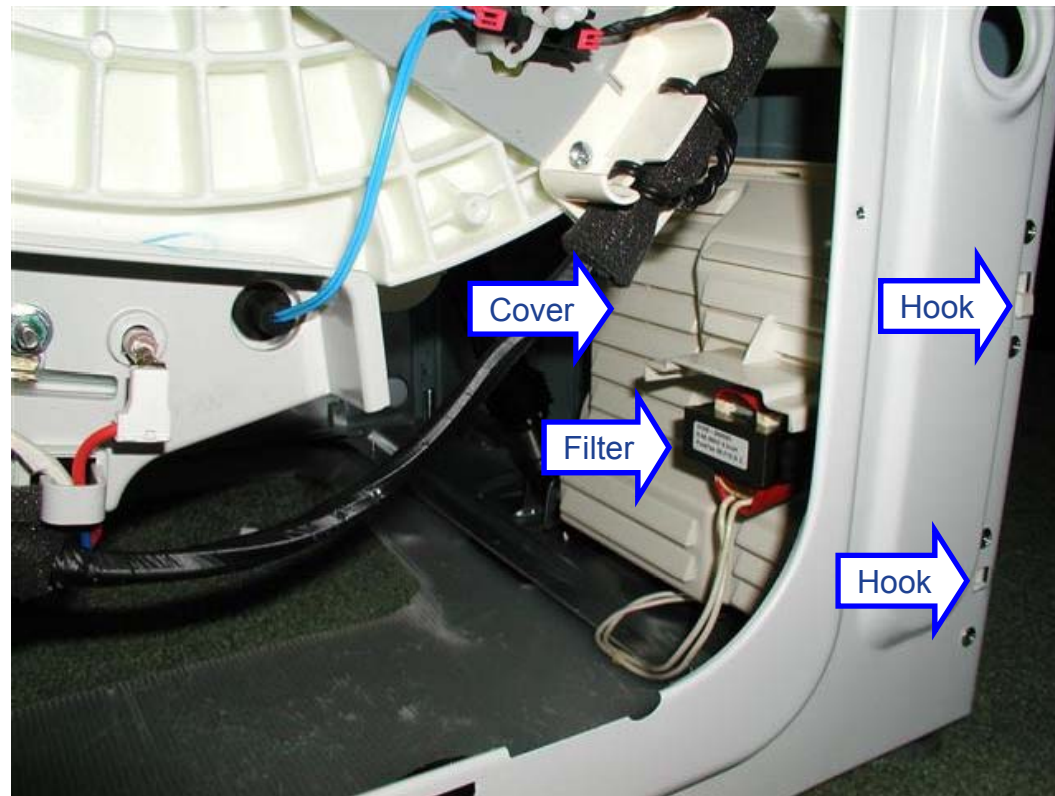

- The main PCB receives commands from the control board and controls washer operation.
- The main PCB is enclosed in a protective housing and cover, located inside the cabinet, under the left side of the outer tub.
- The right-side of the protective housing is attached to the rear of the cabinet with 2 hooks and 4 Phillips-head screws.
- A line filter (Reactor) is attached to the protective housing cover with 2 Phillips-head screws.

Main PC Board



To remove the Main PCB:

- Remove the 4 Phillips-head screws that attach the main PCB to the rear of the cabinet.
- Lift up the main PCB to unhook it from the rear of the cabinet and to clear the post from the cutout in the bottom of the cabinet.

Main PC Board



- Rotate the main PCB 90° clockwise and maneuver it out from the cabinet.

Main PC Board



- Pry open cover to access components and plug connections.

Main PC Board

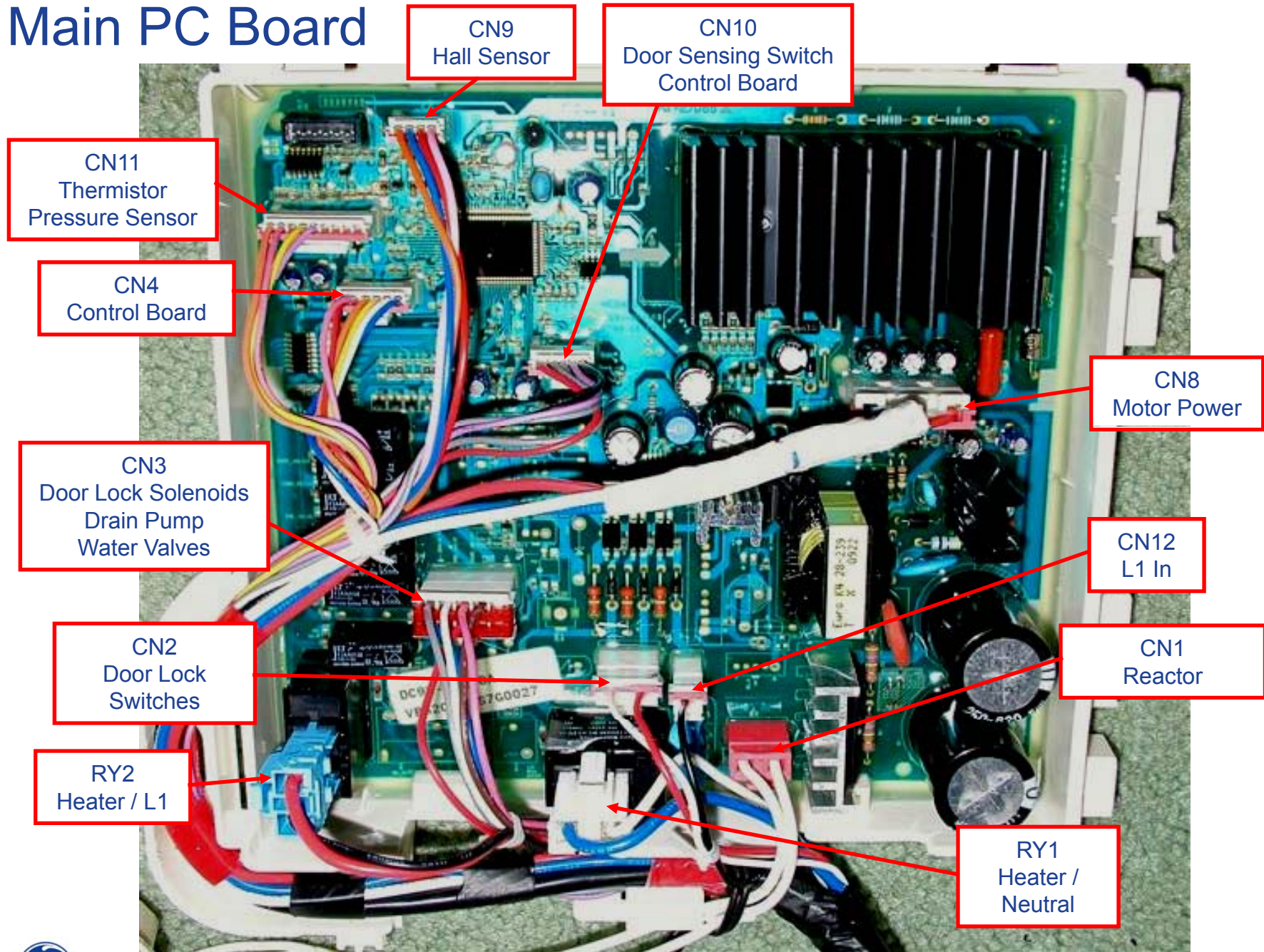

Tub Gasket

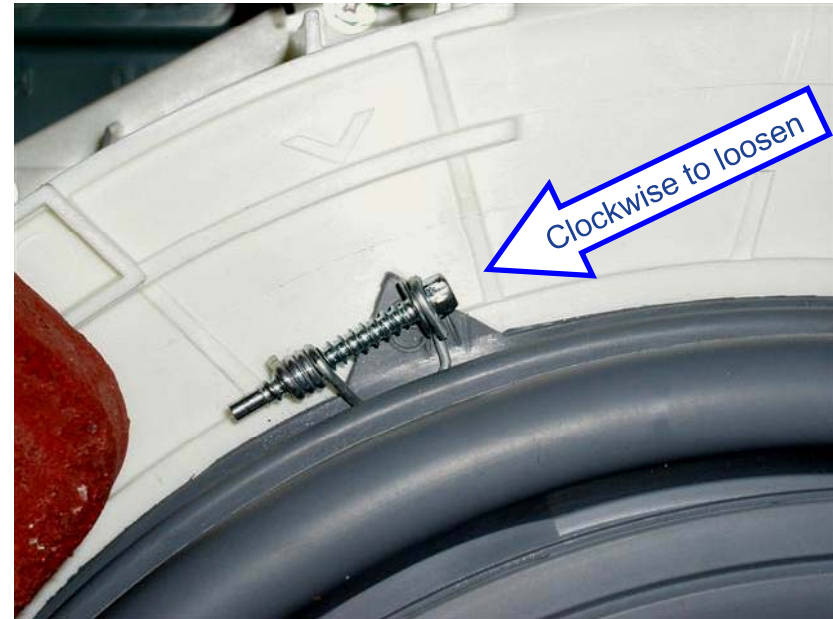

- The front of the tub gasket is secured to the front panel flange by a spring and wire located in the lower fold of the gasket.
- The back of the tub gasket is attached to the outer tub lip with a wire and bolt gasket clamp.
- Turn the 7-mm bolt **clockwise** to loosen the clamp that secures the tub gasket to the outer tub lip.

Tub Gasket

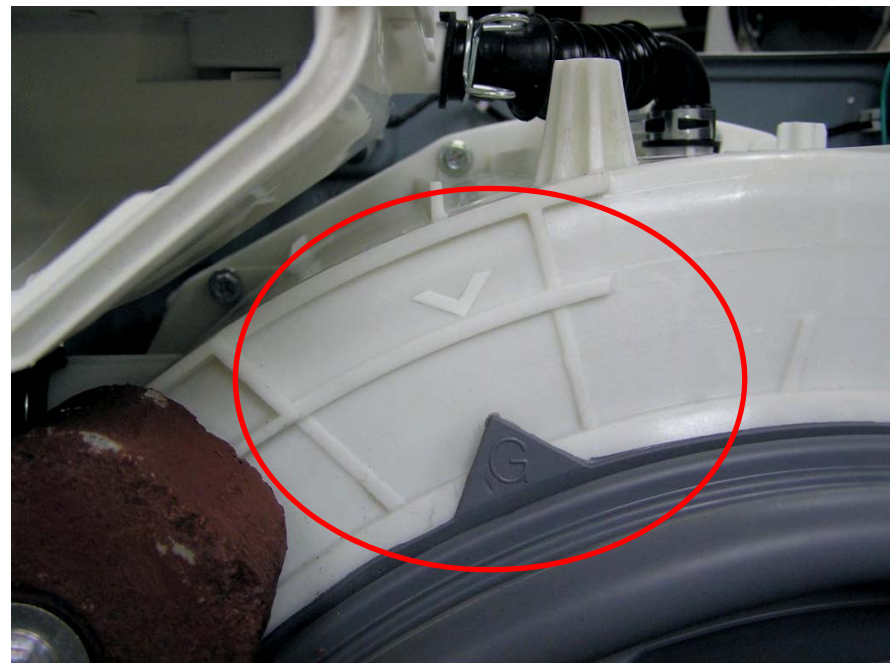

- After removing clamps, pull the tub gasket from the outer tub lip.

Note: When installing the tub gasket on the outer tub, align the tab on the gasket with the arrow located on the front of the outer tub before installing and tightening the clamp bolt.

Outer Tub Assembly



- The outer tub assembly is constructed in two halves and contains the wash basket.
- The bearing and seal assembly is part of the outer tub rear half.
- The outer tub assembly is supported by 2 suspension springs and 2 dampers.
- Each spring is located between the top of the tub assembly and a cabinet top brace, one on each side.
- Washer stabilization is achieved by the use of 2 dampers that are located between the bottom of the tub assembly and chassis, 1 on each side.

Outer Tub Assembly Removal

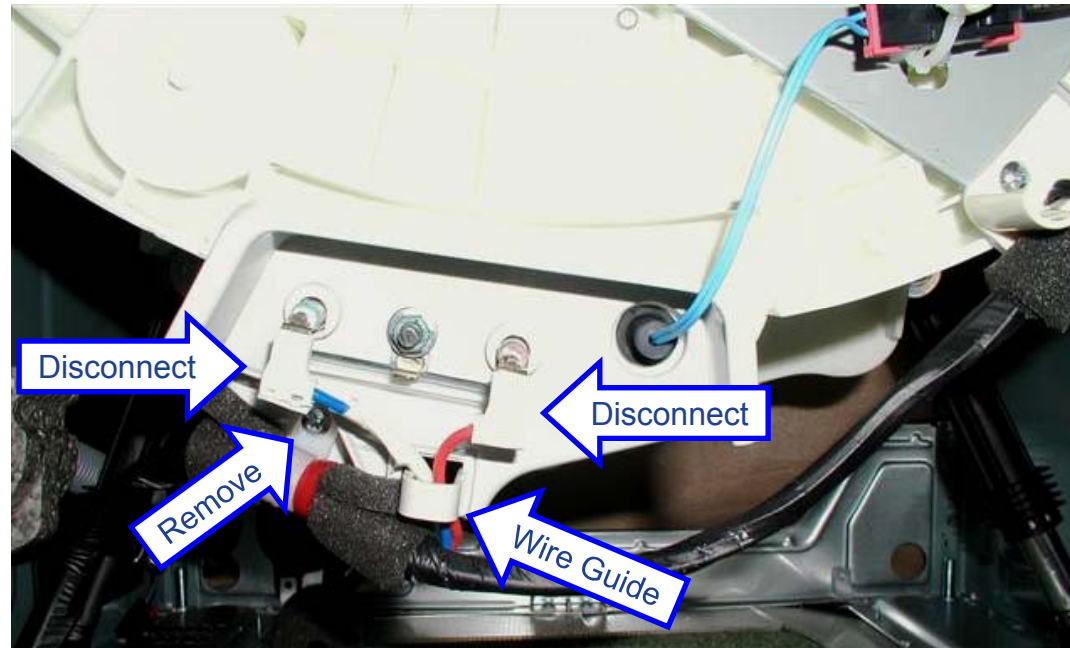

WARNING: The outer tub assembly is heavy and requires two people to remove it from the washer cabinet. Care should be taken when removing and installing the outer tub assembly.

- After removing the top cover, control panel, front panel and back cover, drain the washer using the pump drain hose.
- Disconnect the blue and red wires from the heater. Remove both wires from the wire guide.
- Remove the Phillips-head screw that attaches the motor wire harness clamp to the heater shield.

Outer Tub Assembly Removal

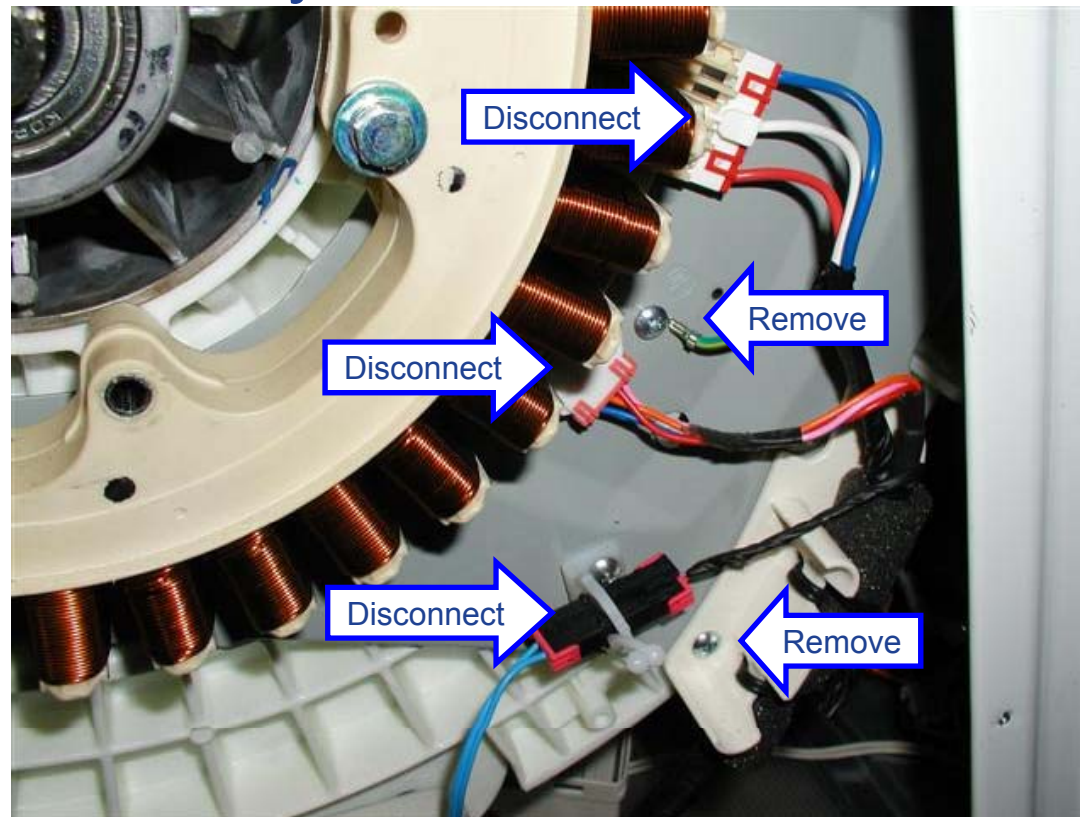

- Disconnect the thermistor wire harness.
- Disconnect the stator and Hall sensor wire harnesses from the motor.
- Remove the Phillips-head screw that attaches the ground screw to the motor cover.
- Remove the Phillips-head screw from the motor harness support, then slide the support up and pull it out from the motor cover.

Outer Tub Assembly Removal



- Remove the dispenser vent hose from the outer tub:
 - a. Squeeze the clamp and slide it back.
 - b. Carefully break the vent hose loose by inserting a small flat-blade screwdriver under the hose to break the seal.
 - c. Remove the hose.

Note: When installing the dispenser vent hose, ensure the notch cutout is engaged with the right side tab on the tub inlet.

Outer Tub Assembly Removal



- Remove the dispenser from the front and left side braces, then remove the dispenser outlet hose from the dispenser.
- Place the dispenser assembly over the left rear corner of the washer.

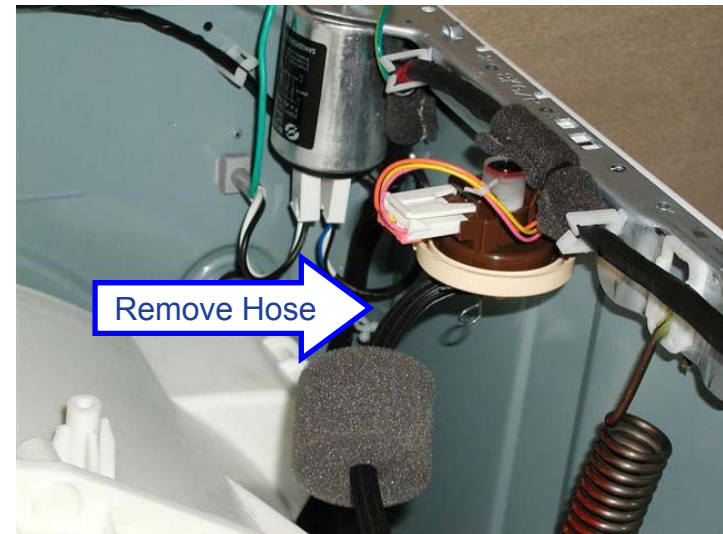

- Remove the pressure sensor hose from the pressure sensor.

Outer Tub Assembly Removal

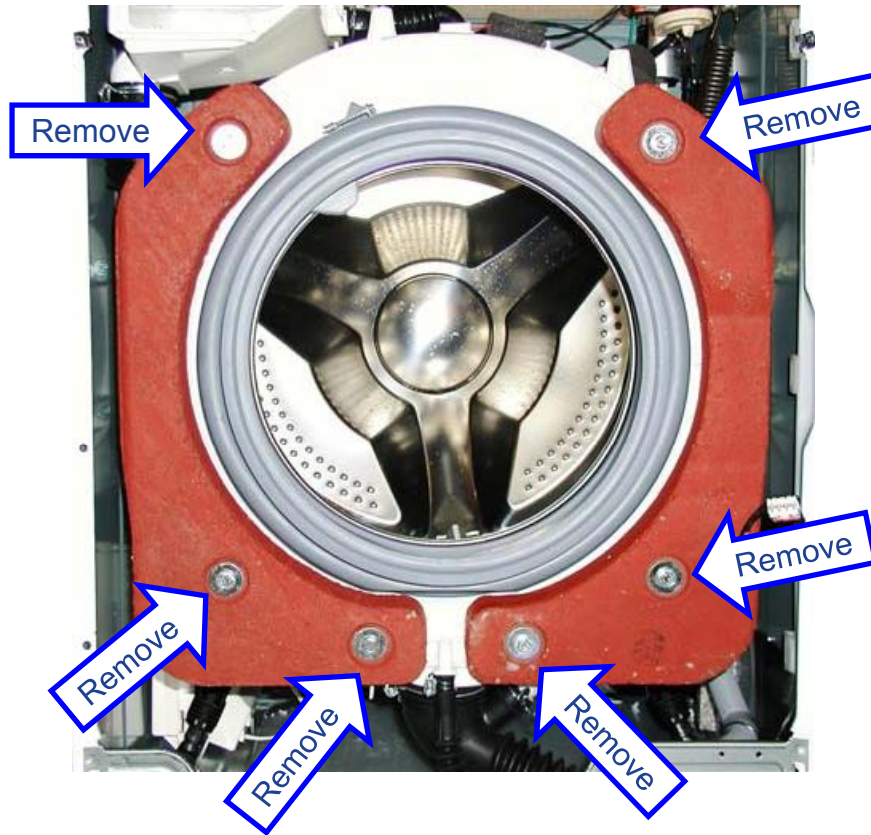

Remove the three 10-mm hex head bolts and washers that attach each of the 2 counterweights to the front of the outer tub.

Outer Tub Assembly Removal

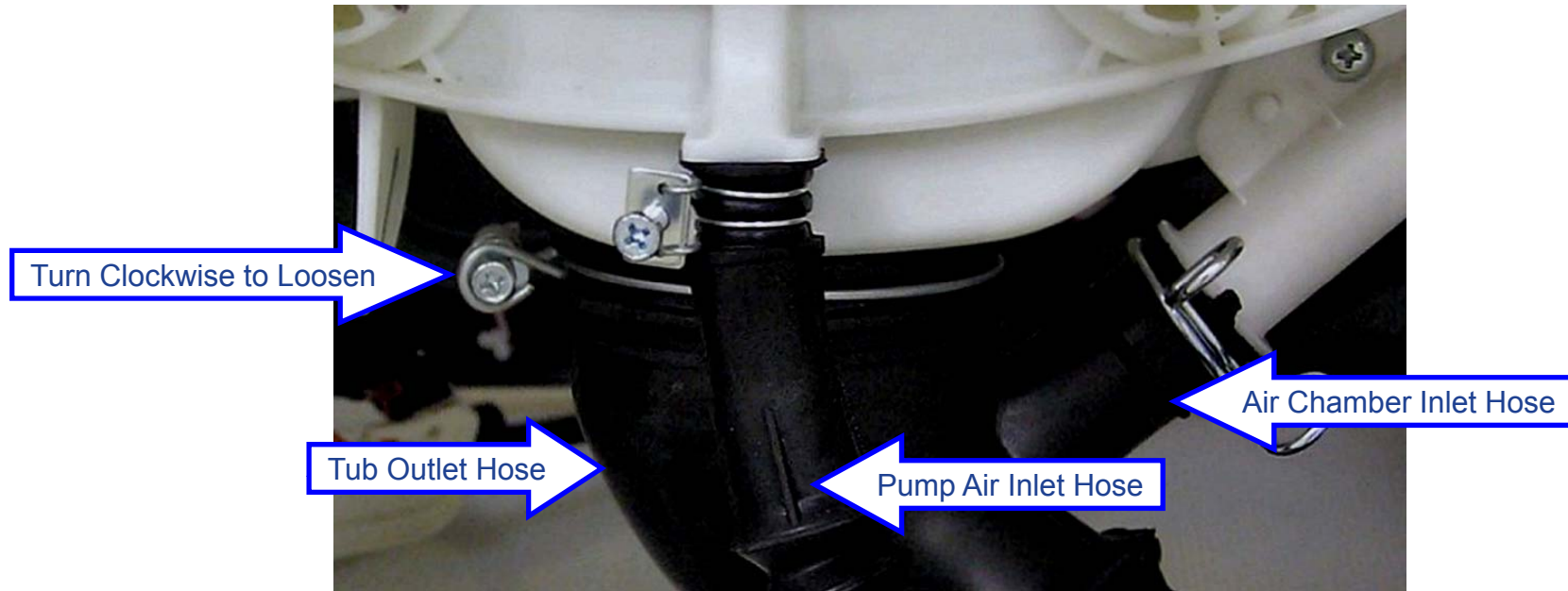

- Turn the Phillips-head clamp screw **clockwise** to loosen the clamp that secures the tub outlet hose to the outer tub.
- Remove the tub outlet, air chamber inlet and pump air inlet hoses from the tub.

Note: The Phillips-head clamp screw on the tub outlet hose uses reverse rotation to tighten or loosen the hose. It is necessary to turn the Phillips head clamp screw **clockwise** to loosen the clamp.

Outer Tub Assembly Removal

- Remove the 10-mm hex head screw and washer from the top of each damper.
- Lift the rear of the tub assembly to maintain a level position, then pull each damper straight out from the outer tub.
- Position the dampers parallel to the bottom of the washer.



Outer Tub Assembly Removal



- Lift the outer tub assembly up, then release the 2 suspension springs from the slotted plastic inserts in the cabinet top braces.
- Carefully remove the tub assembly out the front of the cabinet, then place the tub assembly on a protective surface with the air chamber at the 2 o'clock position, as shown below.

Outer Tub Assembly Removal

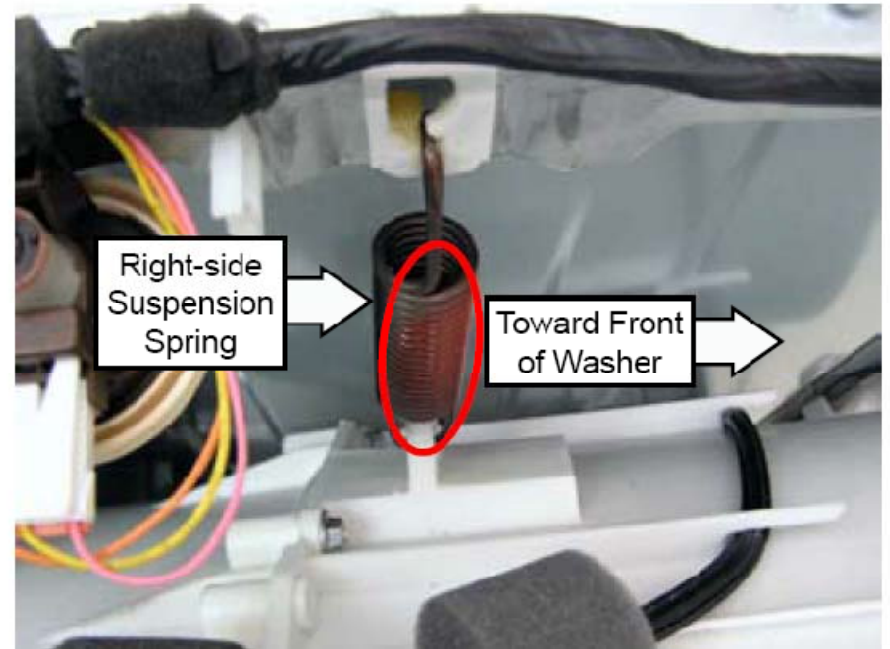
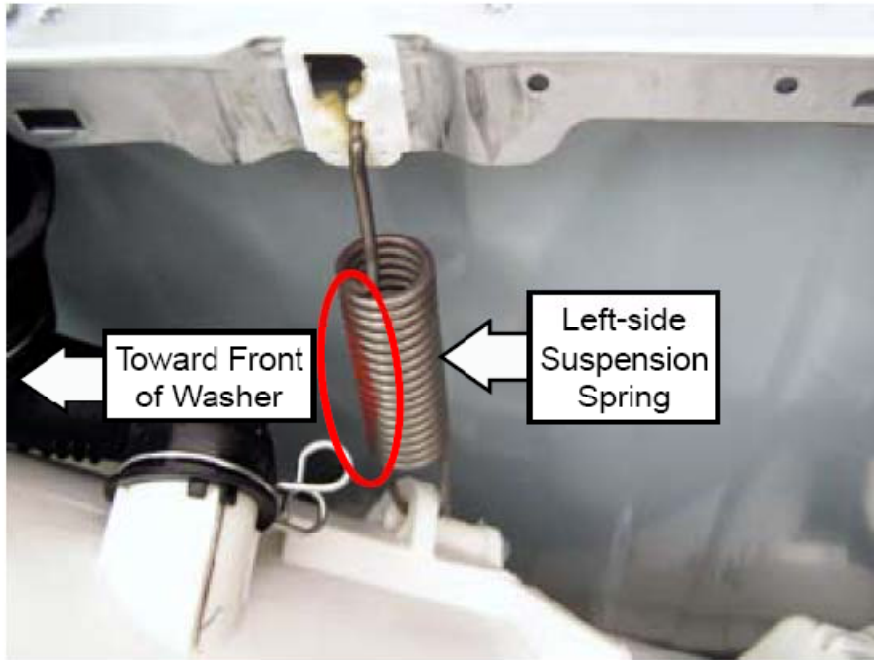

Note: When re-installing the outer tub assembly, install each suspension spring with the red paint facing toward the front of the washer.

Wash Basket



- The wash basket is contained inside the outer tub.
- To remove the wash basket it will become necessary to separate the outer tub halves.

Wash Basket

To remove the wash basket:

- After removing the motor assembly, suspension components, counter weights and gasket, remove the tub assembly from the washer cabinet.
- Carefully position the tub assembly, motor side down, on a clean, protective surface.
- Remove the single 10-mm hex head screw, located near the dispenser inlet, that faces the tub rear.
- Remove the fifteen 10-mm hex head screws that hold the tub front and tub rear together.

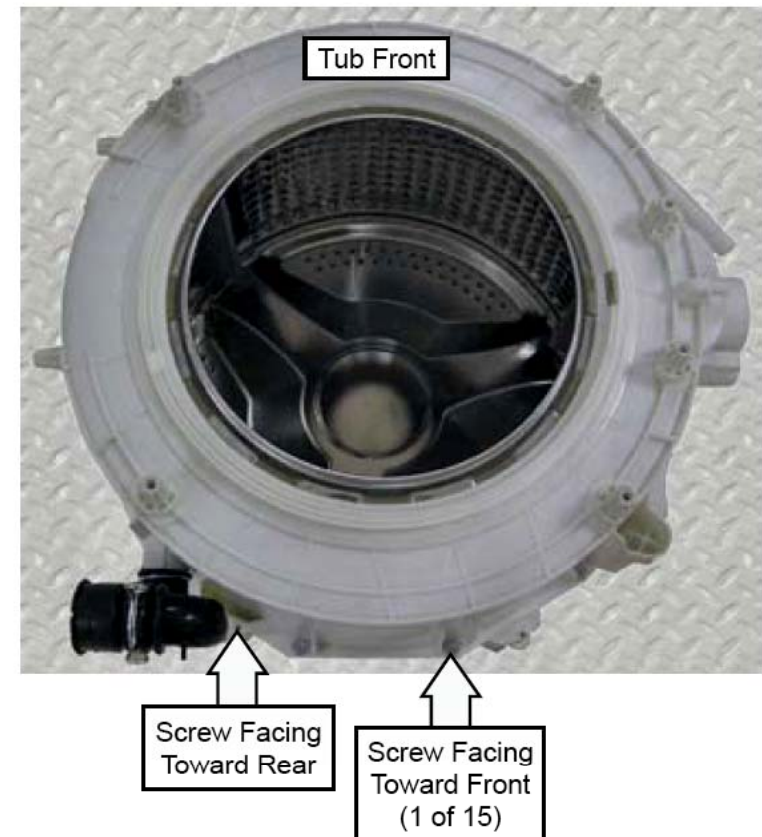

Wash Basket



- Separate and remove the tub front from the tub rear.
- Pull the wash basket out from the tub rear.
- Wash basket can be ordered as a complete assembly.

Service Mode

TO ENTER SERVICE MODE: Press (while unit is in idle):
Signal – Extra Rinse – Signal – Extra Rinse

TO EXIT SERVICE MODE: Press Power Button or no button pressed
for 15 minutes.

General Navigation

- Upon entering the service mode, the SSD shall display the first test number t01.
- Rotating the knob counter-clockwise (CCW) decrement the test number in the display.
- Rotating the knob clockwise (CW) increment the test number in the display.
- Once the test number is selected, pressing **Start/Pause** will begin the selected test.

Service Mode Selections

1. t01 Software version number test (UI, MC)
Check the software version.
2. t02 Error codes
Check for any error codes reported by the controls.
3. t03 User interface test
Verifies all LEDs operate correctly.
4. t04 Water valve and dispenser test
Verifies operation of the individual water valves
5. t05 Water level sensor test
Fills to overflow water level, then pumps out water.
6. t06 Drain Pump test
Test drain pump.
7. t07 Heater and Thermistor test
Test the heater and thermistor. The estimated temperature by fahrenheit is displayed to SSD.
8. t08 Tumble test
Verifies washer tumbles (i.e., Wash Cycle).
9. t09 Spin test
Verifies washer spins. Note: No out of balance detection will be performed here, so the washer will spin up regardless of the out of balance that is placed in the drum.

Service Mode Sequences

Service mode test		Sequence	
T01	Version Display	Enter	Display software version
		Power	Returns to service mode screen
T02	Error Codes	Enter	Displays error codes
		Start/Pause	Clears highlighted error code from machine
		Power	Returns to service mode screen
T03	User interface test	Enter	Turn all remaining LED
		Power	Returns to service mode screen
		Enter	Display "U"
T04	Water valve and dispenser test	Soil Button On	Turn on cold water valve and All Soil Level LEDs turn On
		Soil Button Off	Turn off cold water valve and All Soil Level LEDs turn Off
		Temp Button On	Turn on hot water valve and All Temp LEDs turn On
		Temp Button Off	Turn off hot water valve and All Temp LEDs turn Off
		Spin Button On	Turn on bleach valve and All Spin speed LEDs turn On
		Spin Button Off	Turn off bleach valve and All Spin speed LEDs turn Off
		Signal Button On	Turn on bleach valve + cold valve together and signal LED turns on
		Signal Button Off	Turn off bleach valve + cold valve together and Signal LED turns Off
		Power	Returns to service mode screen

T05	Water level sensor test	Enter	Turn on the cold water valve, the water level frequency continue updating on SSD
		Power	Drain and return to service mode screen
T06	Drain Pump test	Enter	Turn on the drain pump
		Power	Returns to service mode screen
T07	Heater and Thermistor test	Enter	On entry, the control will display the estimated temperature (0 F) turn on the cold valve and heater is turn on The water temperature sensor test displays the water temperature trend in the display, if the sensor is reading falling temperature from the baseline it will blink the numbers in the display, if it senses raising temperatures it will solid the numbers in the display.
		Power	Returns to service mode screen
T08	Tumble test	Enter	Unit tumbles
		Power	Returns to service mode screen
T09	Spin test	Enter	Displays "estimated" and "current" rpm
		Power	Returns to service mode screen

Error Codes

Error Code	Description	Action
E00	no errors	
4E	Water valve problem	<ul style="list-style-type: none"> • Check whether the faucet is closed, the water supply has been suspended or is frozen. • Check whether the filter net in the water supply hose connector is clogged by dirt. • Check whether the cold water is connected. The display will show 4E when the hot water only is connected.
5E	Drain pump problem	<ul style="list-style-type: none"> • The water does not drain due to a clogged drain hose. • Check whether the drain hose is frozen. • Clean the filter of debris. • Check integrity of pump motor. Replace if necessary
OE	Overflow level was reached	<ul style="list-style-type: none"> • Check valve for any signs of leaks. • Check integrity of water level sensor. Replace if necessary.
HE	Heater relay error	<ul style="list-style-type: none"> • Replace the main pcb.
HE1	Heater problem	<ul style="list-style-type: none"> • Check integrity of main pcb. Replace if necessary.
1E	Pressure sensor error	<ul style="list-style-type: none"> • Check integrity of pressure sensor. Replace if necessary.
LE	Leakage error	<ul style="list-style-type: none"> • Check integrity of tub.
9E1	Under voltage error	<ul style="list-style-type: none"> • Measure AC outlet voltage; ensure correct range(120V to 132V AC)
9E2	Over voltage error	<ul style="list-style-type: none"> • Check electrical connections at the motor drive. • Check harness integrity between main control and motor drive. • Unplug the unit, wait 30 seconds and restart the unit. • If the fault persists and re-appear, replace the main pcb. • If the fault persists and re-appear, replace the trans reactor or harness. • If the fault persists and re-appear, replace the motor drive.

3E1	Motor start up failure	<ul style="list-style-type: none"> • Measure AC outlet voltage;ensure correct range(120V to 132V AC)
3E2	Over current error	<ul style="list-style-type: none"> • Check electrical connections at the motor drive.
3E3	Hall sensor error (input the hall sensor under 30 in the running state)	<ul style="list-style-type: none"> • Check harness integrity between main control and motor drive. • Unplug the unit, wait 30 seconds and restart the unit. • If the fault persists and re-appear, replace the motor drive. • If the fault persists and re-appear, replace the main pcb or harness.
3E4	IPM over heating error	<ul style="list-style-type: none"> • Check integrity of main pcb. Replace if necessary.
tE	Water thermistor error	<ul style="list-style-type: none"> • Check integrity of thermister. Replace if necessary.
dE	Door open error	<ul style="list-style-type: none"> • The door is not close. - Please close the door again as the until will not function correctly when the door is left open • Check the door DC switch. Replace if necessary.
dE1	Door lock error	<ul style="list-style-type: none"> • The door is not close. - Please close the door again as the until will not function correctly when the door is left open. • If the fault persists and re-appear, replace the door lock switch.
dE3	Door un lock error	<ul style="list-style-type: none"> • The door is not close. - Please close the door again as the until will not function correctly when the door is left open. • If the fault persists and re-appear, replace the door lock switch. • If the fault persists and re-appear, replace the main pcb.
bE2	Button error	<ul style="list-style-type: none"> • Check the button operation. • If the fault persists and re-appear, replace the sub pcb.
AE	Communication error between Main and Sub PBA	<ul style="list-style-type: none"> • Check the integrity of the wiring between main and sub pcb. • Clear the fault and run the cycle. If fault persists and re-appears, replace the main pcb.
SF	System Failure error	<ul style="list-style-type: none"> • Replace main PBA.
DE2	Door Protection	<ul style="list-style-type: none"> • The door is on and off frequently by pushing the start button in the short time.
UE	Out of Balance error	<ul style="list-style-type: none"> • Machine was unsuccessful in recovering from an out of balance condition during the final spin and 34 minutes was added to the cycle timer.

Schematic

WIRE DRAWING

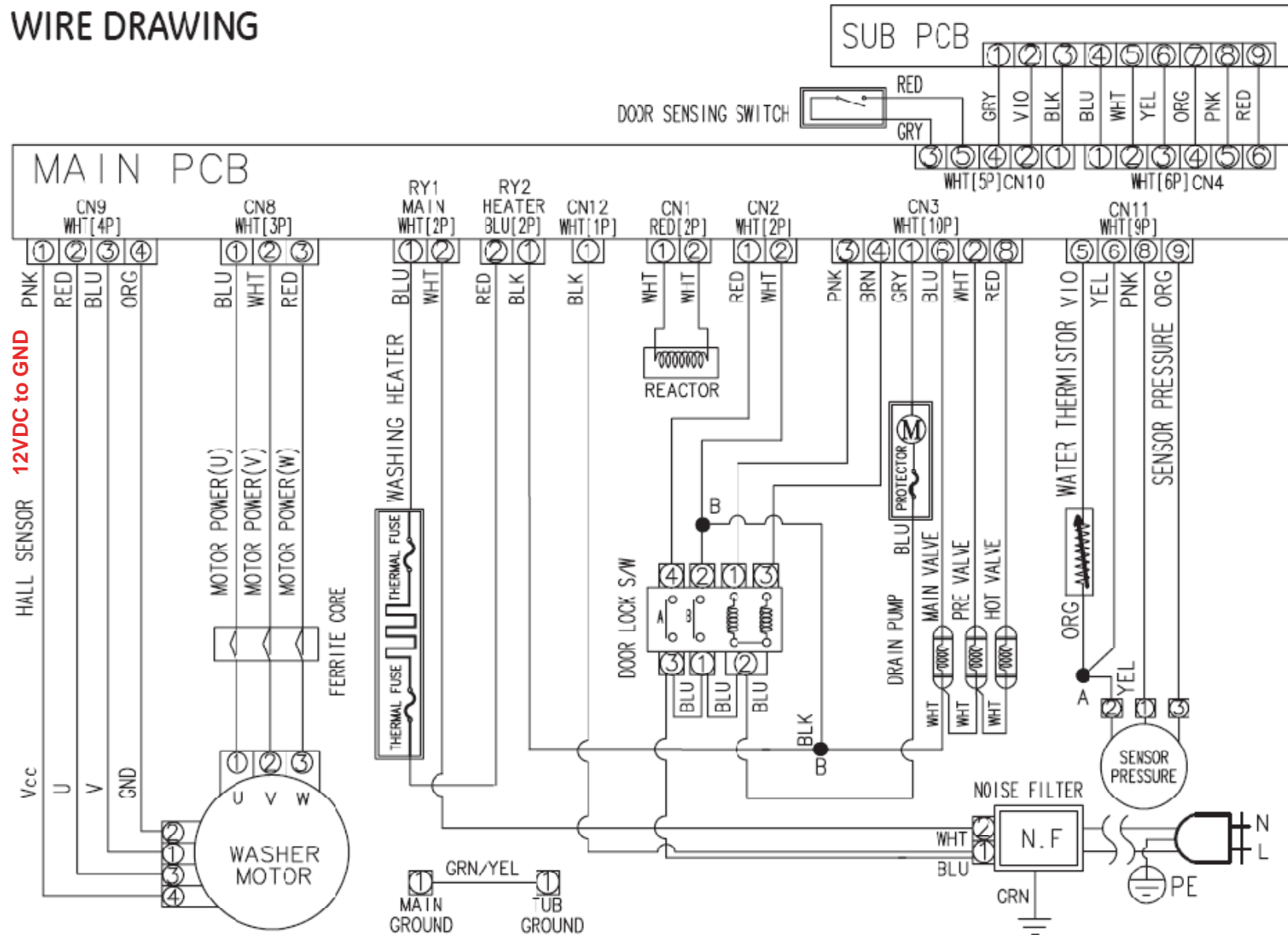

END OF
PRESENTATION
THANK YOU FOR YOUR
ATTENTION

