

# Profile Washer

WPRE6100

WPRE8100



GE imagination at work

# Profile Warranty

## GE Washer Warranty.



All warranty service provided by our Factory Service Centers, or an authorized Customer Care® technician. To schedule service, on-line, 24 hours a day, visit us at [ge.com](http://ge.com), or call **800.GE.CARES** (800.432.2737). Please have serial number and model number available when calling for service.

Staple your receipt here.  
Proof of the original purchase date is needed to obtain service under the warranty.

---

### For The Period Of: We Will Replace:

---

#### One Year

From the date of the original purchase

**Any part** of the washer which fails due to a defect in materials or workmanship. During this **limited one-year warranty**, GE will also provide, **free of charge**, all labor and related service costs to replace the defective part.

---

#### Second through Fifth Year

From the date of the original purchase

**The suspension rod and spring assembly, and main electronic control board**, if any of these parts should fail due to a defect in materials or workmanship. GE will also replace the **washer lid or cover**, if they should rust under operating conditions. During this **additional four-year limited warranty**, you will be responsible for any labor or related service costs.

---

#### Second through Tenth Year

From the date of the original purchase

**The shaft and tube assembly\* and outer washer tub**, if any of these parts should fail due to a defect in materials or workmanship. During this **additional nine-year limited warranty**, you will be responsible for any labor or related service costs.

---

#### Lifetime of Product

From the date of the original purchase

**The washer basket**, if it should fail due to a defect in materials or workmanship. During this **product lifetime limited warranty**, you will be responsible for any labor or related service costs.

---

\* **NOTE:** Includes Mode Shifter.



GE imagination at work

# ATC

- Tap Cold = temperature from cold tap
  - Cold = 62°F
  - Cool = 70°F
  - Colors = 80°F
  - Warm = 95°F
  - Hot = 125°F
- 
- The min fill is 9 gals. & the max is 22 gals.
  - The Thermistor is located in the outlet of the Fill Funnel & will measure 50K $\Omega$  at room temp.
  - The ATC is disabled while the lid is up.
  - The control will de-energize the Water Valve after 45 minutes if the Pressure Switch has not been tripped.

ATC Thermistor

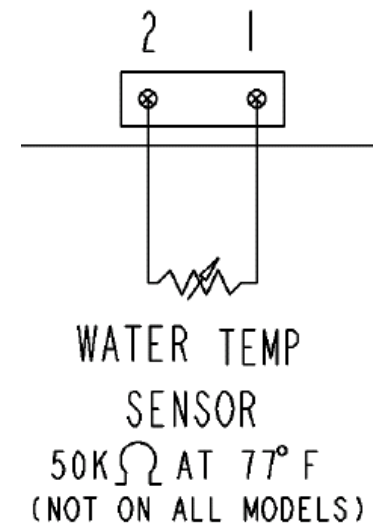
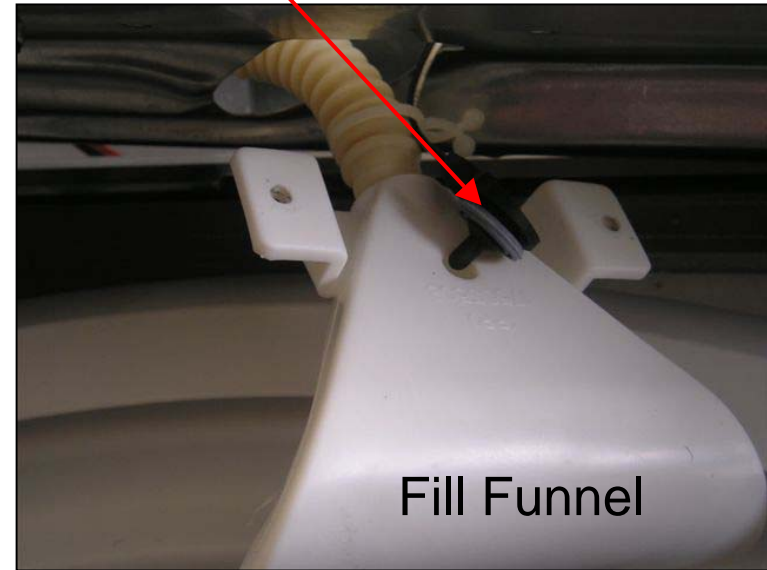

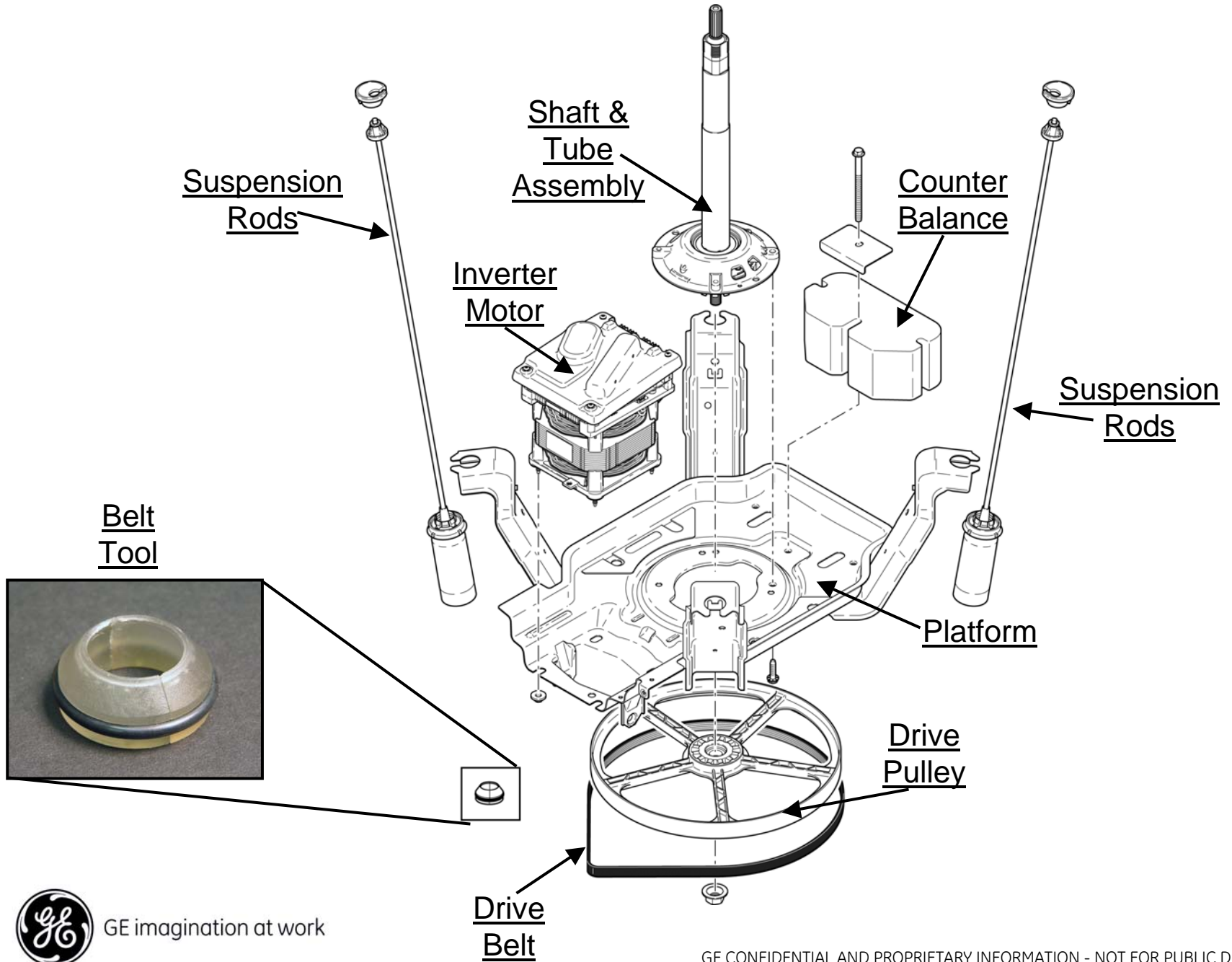

## Mode Shifter Operation - Agitate

- The control energizes the Mode Shifter for the duration of the agitate cycle.
- To ensure agitate of the Mode Shifter to the basket, the control energizes the Mode Shifter & rotates the basket for a short sequence called the Mode Shifter Agitate Program (approx. 18 sec.).
- The Inverter initially outputs (PWM) 135VDC to the Mode Shifter.
- After agitate, the Inverter outputs (PWM) a hold-in voltage of 30VDC.
- There is a normal “clunk” sound at the start of agitation.
- During agitation, there is a normal “swooshing” or “zipping” sound.
- The Mode Shifter will de-energize when washer is paused during agitation.
- If the washer was agitating & the power is disrupted, the control will stop the motor & run the Mode Shifter Agitate Program when power is restored.



## Mode Shifter Operation - Spin

- To spin, the control de-energizes the Mode Shifter (approx. 15 sec.).
- One second after the end of the agitate cycle, the motor will agitate (short, fast strokes) again for 10 sec. to redistribute any unbalance in the basket.
- The control will then de-energize the Mode Shifter & rotate the agitator shaft in a short sequence called – Mode Shifter Spin Program (approx. 30 sec.).
- If the washer was spinning & power is disrupted, the control will re-initiate spin after running the Mode Shifter Spin Program when power is restored.

**NOTE:** It is NORMAL for the washer to continue making sounds for approx. 15 seconds after the washer has paused or turned off; as the Mode Shifter unlocks the basket.



# Fuse Assembly

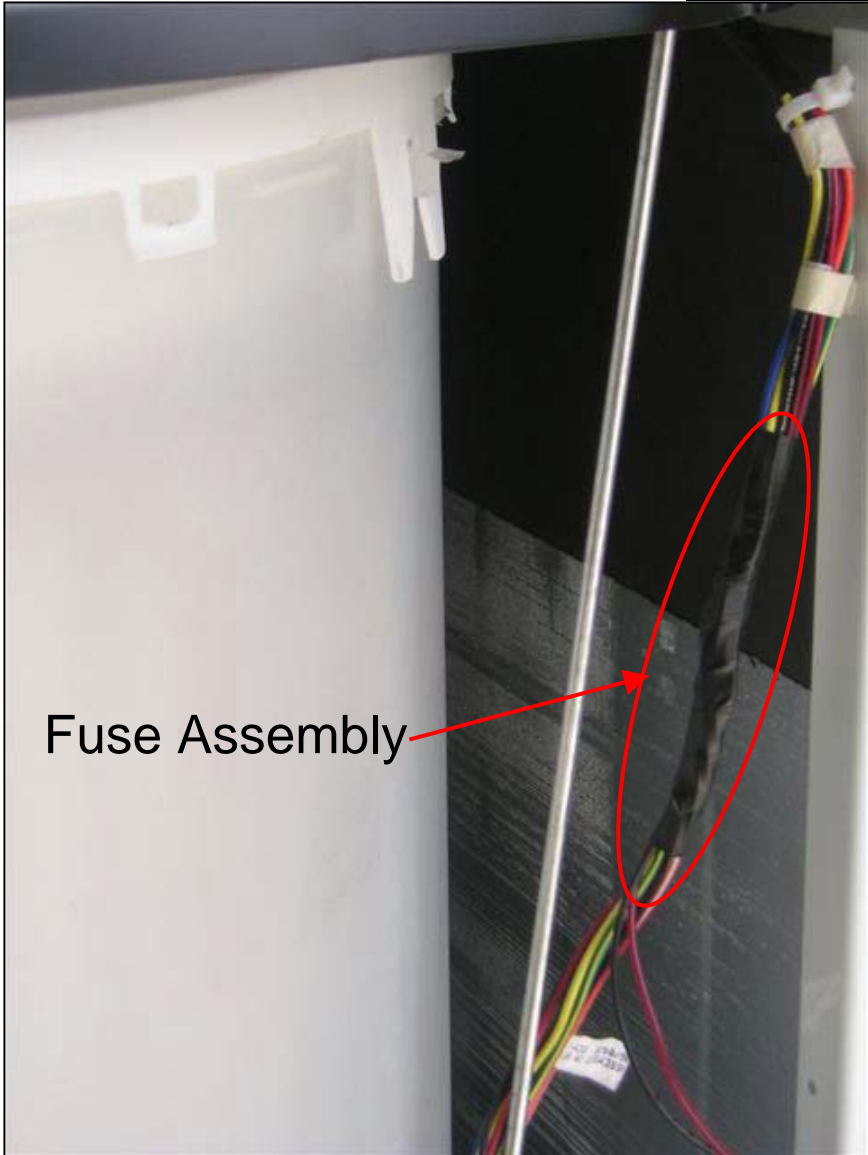

Fuse Assembly

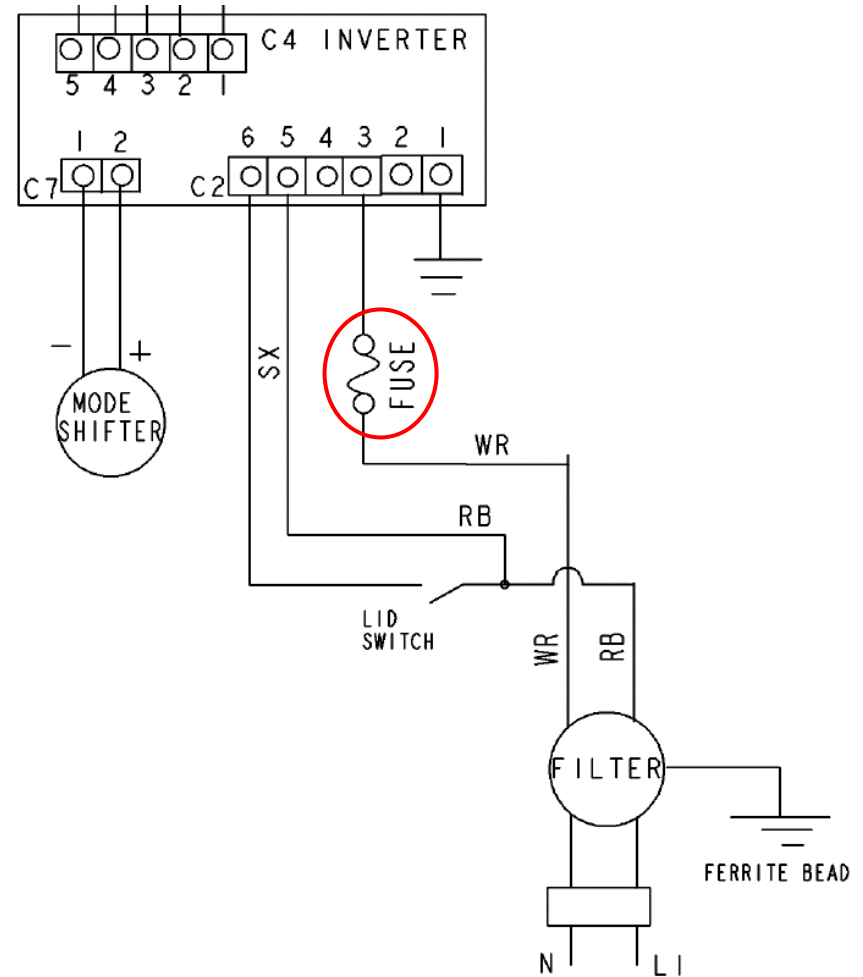

➤ Fuse is on **N** side of line.



# Harness Fuse Kit

## PREPARE EXISTING HARNESS FOR KIT:

1. Disconnect power to washer.
2. Remove front panel.
3. Identify fuse and heat shrink assembly in harness and remove insulation tape on it.
4. Remove fuse assembly from the harness by cutting the wire at both ends of heat shrink ONLY.
5. Strip 1/2" insulation on cut wire for splicing.

## INSTALL NEW FUSE KIT:

1. Splice new fuse assembly to harness with the closed end splices provided in kit as shown. Figure 1
2. Firmly crimp the splices with standard crimp tool.
3. Tape the installed fuse assembly to the main harness. Fully cover the fuse assembly including the splices on both ends, with electrical tape. Make certain both connectors are completely insulated with tape to avoid moisture issues. Figure 2

## KIT CONTENTS:

- Harness Fuse with Leads
- Closed Splice Connectors

## TOOLS AND MATERIALS REQUIRED:

- Crimp Tool
- Electrical Tape
- Wire Cutters

- UL requirement
- If inverter fails (brake resistor)
- If motor exceeds 10A

WH49X10041

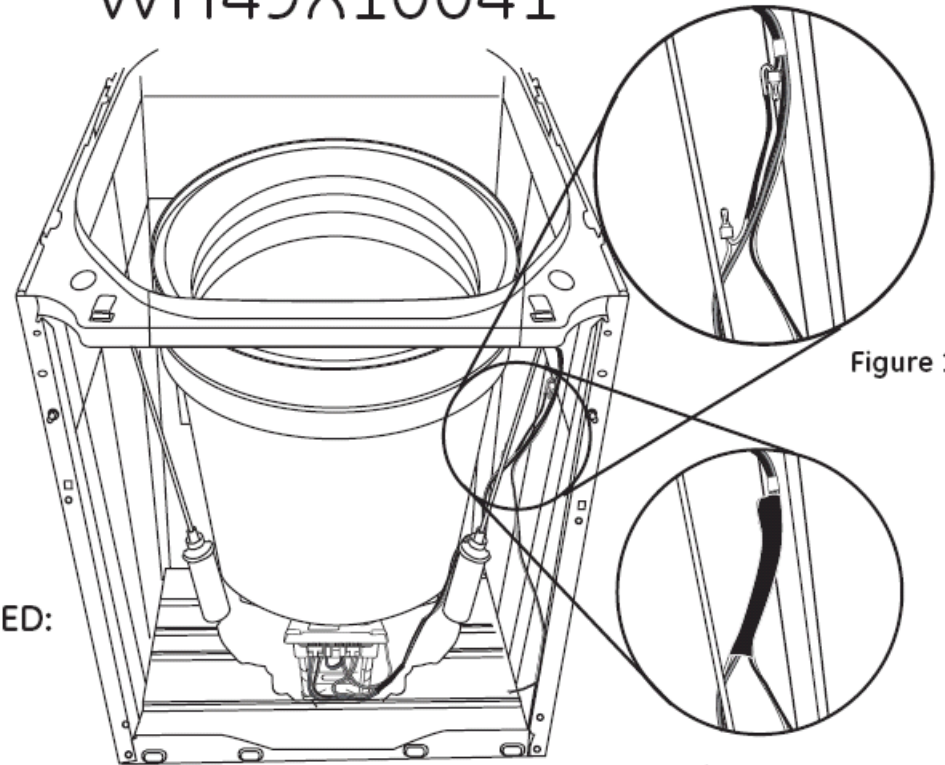

Figure 1

Figure 2





# Inverter/Motor Testing

Voltage readings:

- C2 Pin 1 = **Gnd**
  - C2 Pin 3 = **N**
  - C2 Pin 5 = **L1**
  - C2 Pin 6 = **L1** (Lid Switch)
  - C7 Pin 1 to Pin 2 = 135VDC
  - C7 Pin 1 to Pin 2 = 30VDC
  - C4 Pin 5 to Pin 1 = 9VDC\*
  - C4 Pin 5 to Pin 2 = 9VDC\*
  - C4 Pin 5 to Pin 3 = 9VDC\*
  - C4 Pin 5 to Pin 4 = 9VDC\*
- If you can get washer to go to high spin in Field Service Mode - the board, inverter, & motor are OK.

**\*NOTE:** Place washer in Field Service Mode & test for high speed spin.

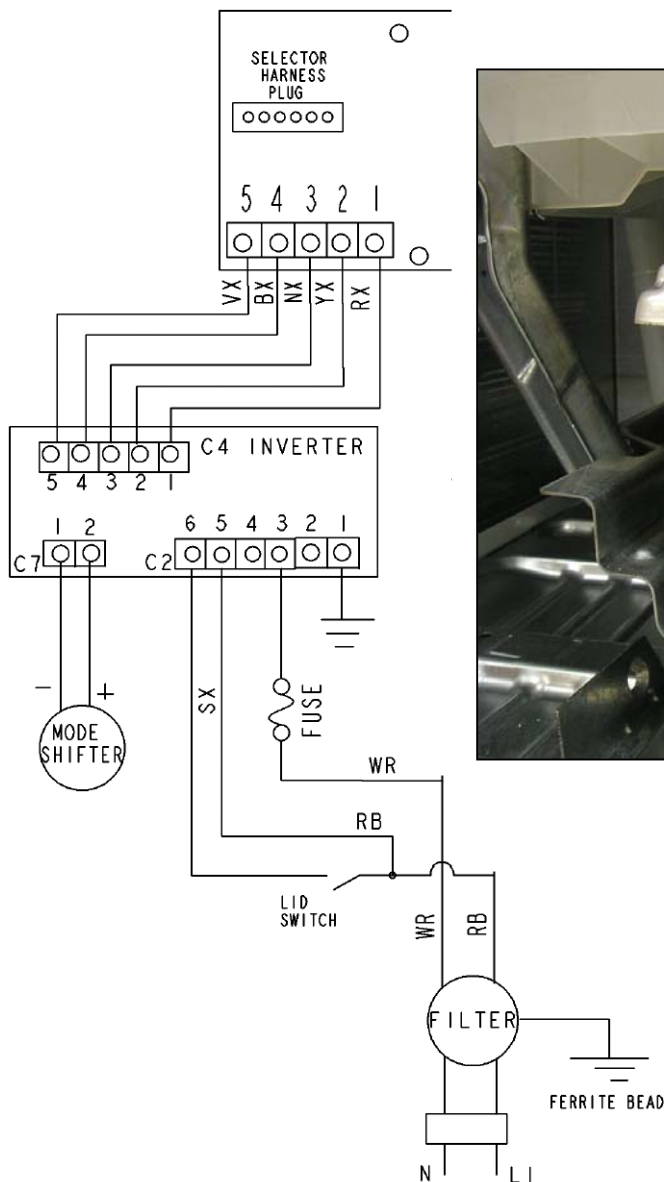

GE imagination at work

# Motor Inverter Signal LED Errors

- Motor/Control error condition – LED is on for .25 seconds & off for .25 seconds during a 6 second period:
  - ❖ Excessive Brake Time – 1 flash indicates basket has not stopped in a specified time.
  - ❖ Broken Coupling/Slipping Belt – 2 flashes indicates the main control senses one instance where shaft speed exceeds 1000rpm, 2 seconds after the shaft was brought to a stop (this will cause washer not to agitate or spin).
  - ❖ Inverter ROM – 3 flashes indicates the ROM software is defective.
  - ❖ Mode Shifter – 4 flashes indicates the Mode Shifter circuit has failed (motor will continue to operate as normal).
  - ❖ Locked Rotor – 6 flashes indicates the motor is in a locked rotor condition. The motor attempts to start & if it fails, it will sit idle for 15 seconds, then retry (3 times) & if it fails to start will set the Error.
  - ❖ Lid Error – 7 flashes indicates main control has detected a failed lid switch.
  - ❖ Motor Over Temp – 8 flashes indicates the motor is overheated (motor will move in shorter strokes & have lower spin speeds).
  - ❖ Brake Error – 9 flashes indicates the brake resistor circuit has failed (the Inverter will limit max spin speed to 50rpm).
- To clear errors, the lid switch is opened & closed 5 or more times in any 12 seconds within the first 30 seconds of power-up (this will not occur if washer is in either agitate or spin).
- Critical Errors are #1, #2, & #7 – they will prevent Motor/Inverter from operating.



# Mode Shifter Coil Testing

- Remove C7 from inverter.
- Place meter leads into connector to read Ohms.
- Meter should read approx.  $98\Omega$ .

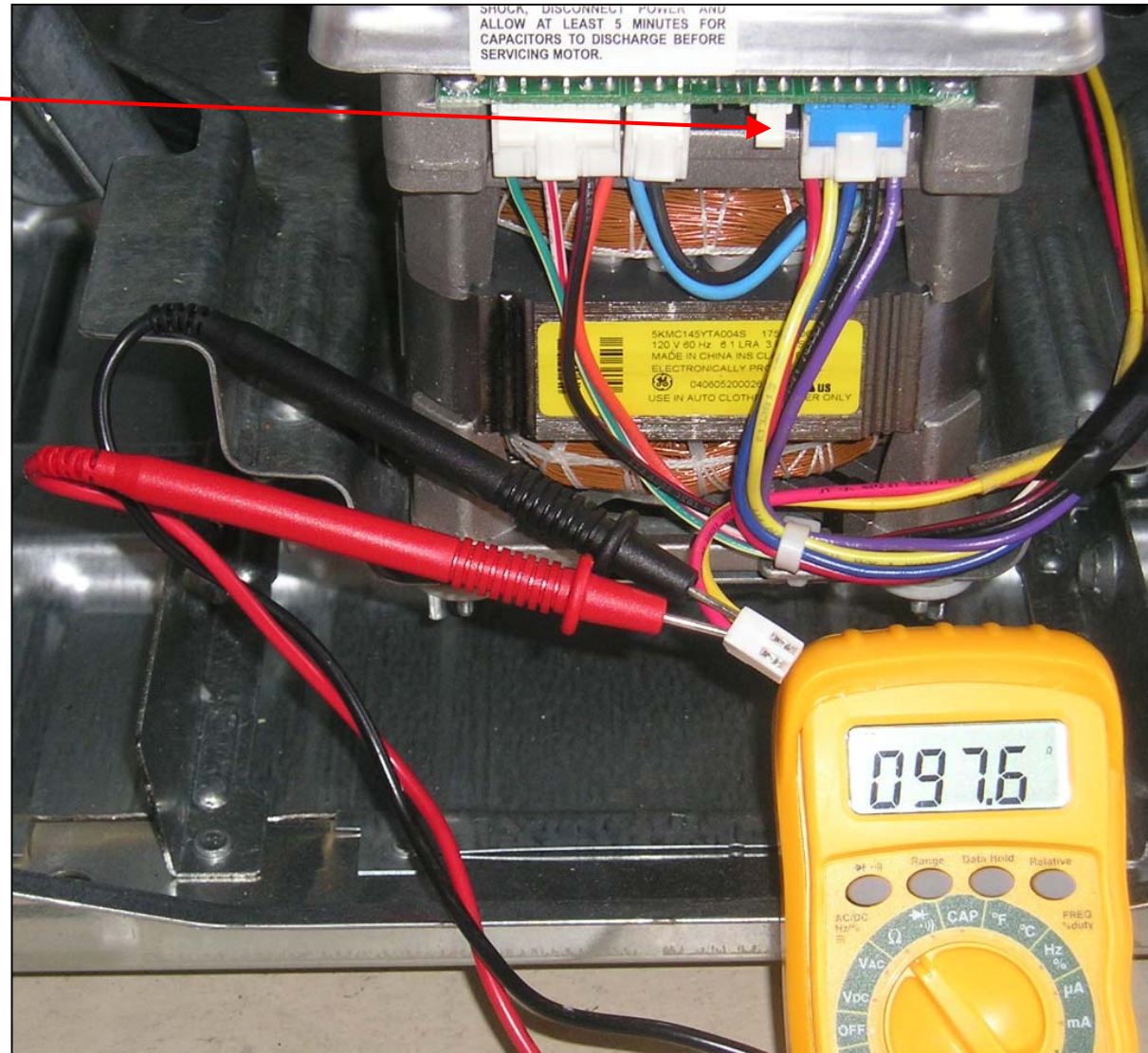
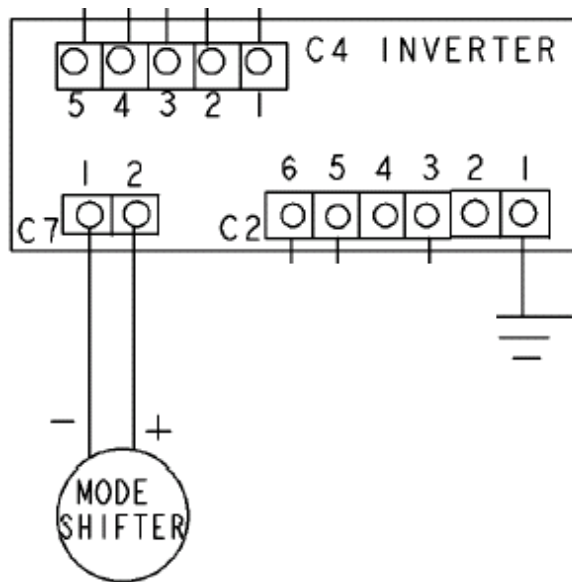

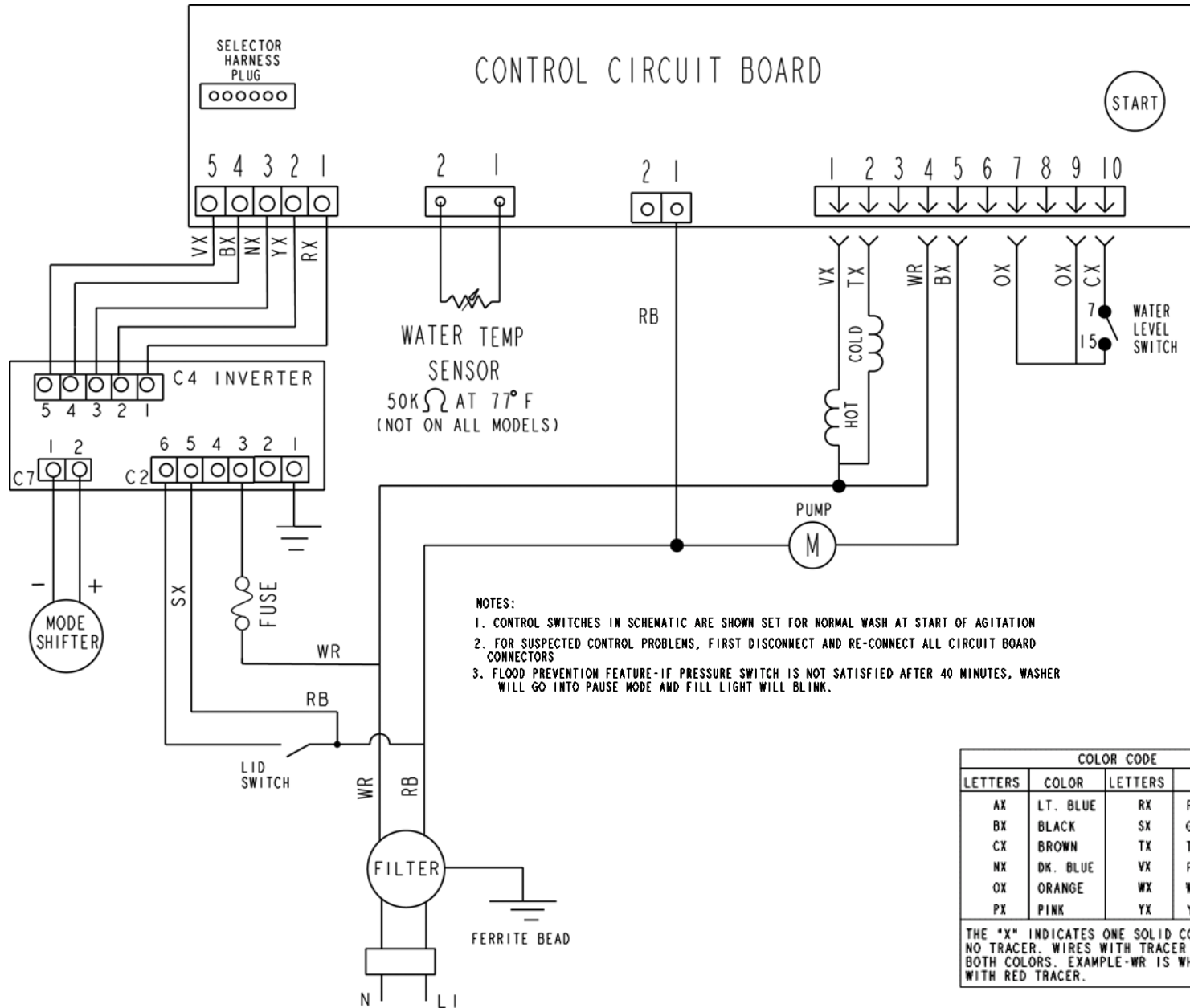

COLOR CODE			
LETTERS	COLOR	LETTERS	COLOR
AX	LT. BLUE	RX	RED
BX	BLACK	SX	GRAY
CX	BROWN	TX	TAN
NX	DK. BLUE	VX	PURPLE
OX	ORANGE	WX	WHITE
PX	PINK	YX	YELLOW

THE "X" INDICATES ONE SOLID COLOR-NO TRACER. WIRES WITH TRACER SHOW BOTH COLORS. EXAMPLE-WR IS WHITE WITH RED TRACER.