

# Improved GE Top Load Washers For 2012

## New Model Numbers

**GTWN5950D**  
**GTWN5550D**  
**GTWN5450D**  
**GTWN5250D**  
**GHWN4250D**  
**GLWN2800D**  
**GCWP1805D**  
**HTWP1200D**

**GTWN5750D**  
**GTWN5350D**  
**GHWN5250D**  
**GCWN4950D**  
**GTWN4250D**  
**GTWN2800D**  
**GCWP1800D**

**GLWN5550D**  
**GTWN5650D**  
**GLWN5250D**  
**GTWN4950D**  
**GCWN2800D**  
**GTWP2250D**  
**GTWP1800D**



## IMPORTANT SAFETY NOTICE

The information in this presentation is intended for use by individuals possessing adequate backgrounds of electrical, electronic, & mechanical experience. Any attempt to repair a major appliance may result in personal injury & property damage. The manufacturer or seller cannot be responsible for the interpretation of this information, nor can it assume any liability in connection with its use.

## WARNING

To avoid personal injury, disconnect power before servicing this product. If electrical power is required for diagnosis or test purposes, disconnect the power immediately after performing the necessary checks.

## RECONNECT ALL GROUNDING DEVICES

If grounding wires, screws, straps, clips, nuts, or washers used to complete a path to ground are removed for service, they must be returned to their original position & properly fastened.

GE Factory Service Employees are required to use safety glasses with side shields, safety gloves & steel toe shoes for all repairs.



**Dyneema<sup>®</sup> Cut Resistant Glove**



**Electrically Rated Glove and Dyneema<sup>®</sup> Cut Resistant Glove Keeper**



**Plano Type Safety Glasses**



**Steel Toe Work Boot**



**Brazing Glasses**

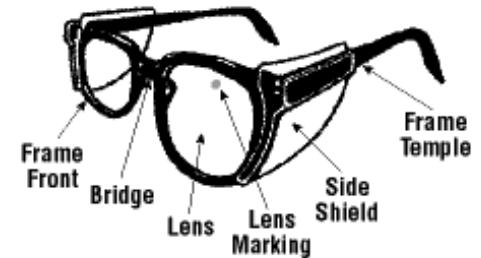

**Prescription Safety Glasses**

**Safety Glasses must be ANSI Z87.1-2003 compliant**

# Getting the Job Done Ergonomically.

GE Factory Service Employees are required to use safety glasses with side shields, safety gloves & steel toe shoes for all repairs.

## Posture

Proper Posture and body position can keep you from injuring your back, arms, shoulders and knees! **Keep Wrist Neutral! Not bent!**



**Horizontal reach!**

Do work close to the body.



**Keep the work close!**

Reduce reach distance and use ergo assist devices.



**Keep Wrist Neutral!**

Not bent!



**Twist and Shout!**

Do not twist at the waist.



**Butts Up!**

Keep your back straight and bend at the knees.

# Program Overview



So what does the 2012 AP1 VA Upgrade Program include?

- Capacity Increase
- A New Look for the backsplash, one knob control with button modifiers.
  - - New to AP1 platform
- Major Components affected:

- Balance Ring - **Taller**
- Tub Cover - **Taller**
- Rod & Spring Suspension System - **Longer**
- Platform - **Shorter**
- Shaft & Tube Assembly - **Shorter**
- Infusor - **Holes**
- Counterweight - **Larger**
- Motor drip shield
- New Backsplash



- Matching Dryer with new control and updated appearance.

# 2012 Top Load Washers

## New Features

New platform for ease of motor removal

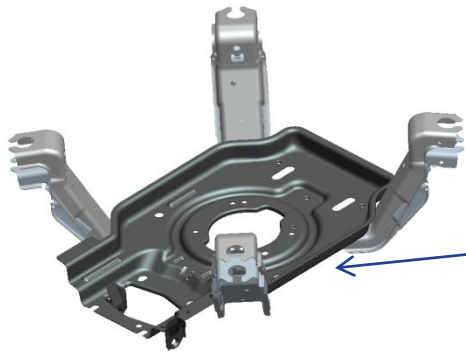

Current

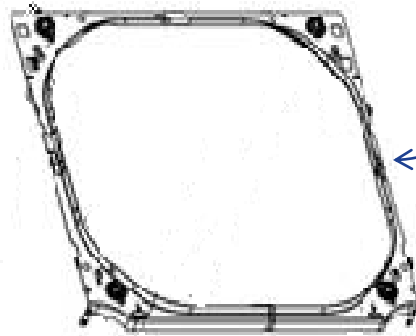

New

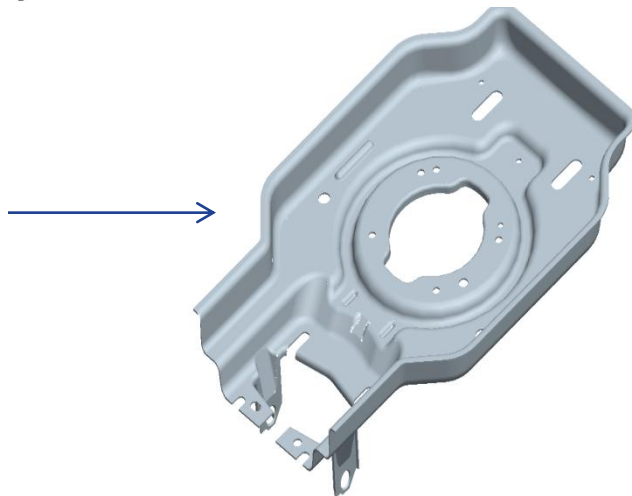

Unit will have the new one piece frame to replace this current three piece frame

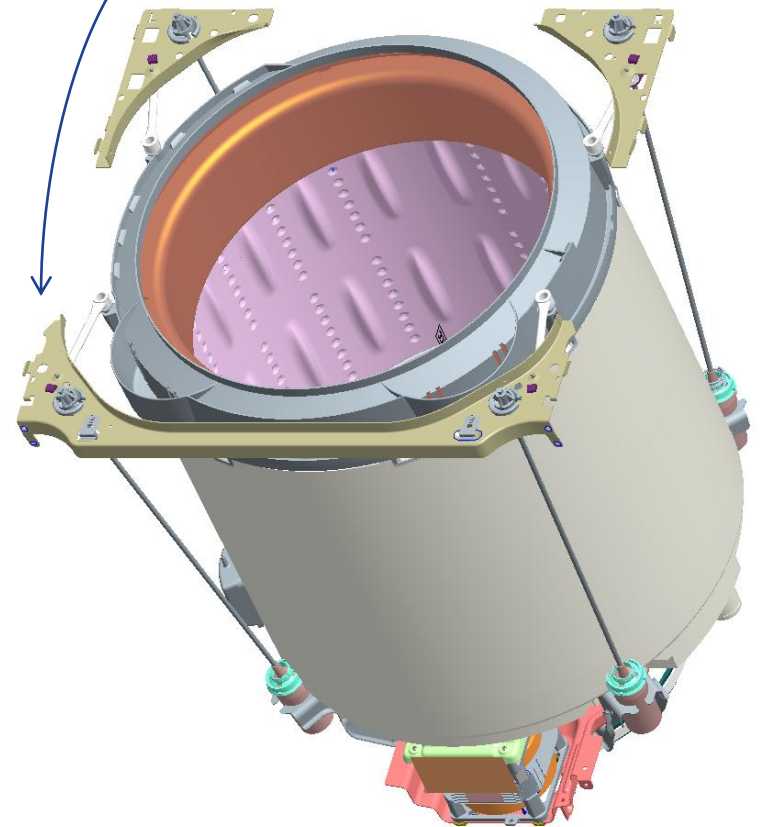

# Controls Overview

## Control Highlights

- Replaces Current Backsplash
- DSM Capable- (Demand Side Mgr.)
- “Smart” Appliance-(preset settings, prompt for delay start during peak electric usage)
- Allows User Delay wash Cycle
- Eco Mode –Limits options...Temp reduction, Longer spin time for more moisture, etc.
- Retain Current Temperatures with LED Spacing
- Backsplash Increases Height by ~0.5”
- Wash Performance Improvements- Allows for a better turnover rate.

## New Parts Introduced

1. Backsplash
2. Control Board
3. Control Interface
4. Center Knob
5. Harness
6. Pressure Sensor



# Subwasher Overview

## Current Production

## Phase 1



Clearance to cover maintained.  
Tub cover and balance ring grow  
by 1.5"

-Platform legs get 1.5" shorter  
-Suspension rods get 1.5" longer

Clearance to pan maintained

## Subwasher Design Change Details:

### \* Performance Adjustments

- New balance ring design Taller
- New Tub Cover
- Suspension modifications
- Counterweight Redesign
- Shipping rod bracket modifications

### \* Motor Serviceability:

- Platform Modifications makes it easier to remove the motor
- Washer Tub Rib Removal



# Subwasher Overview

## Motor Mounting

Slots cut in the platform for easy motor removal.

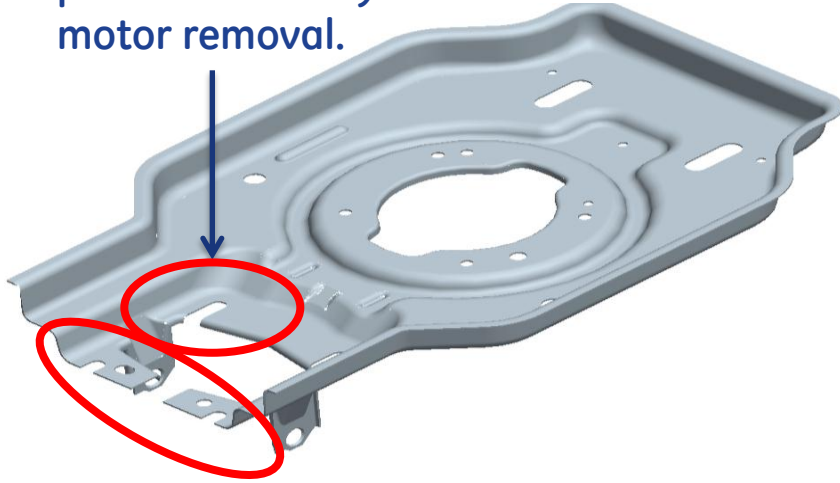

Shorter platform legs (1.5")

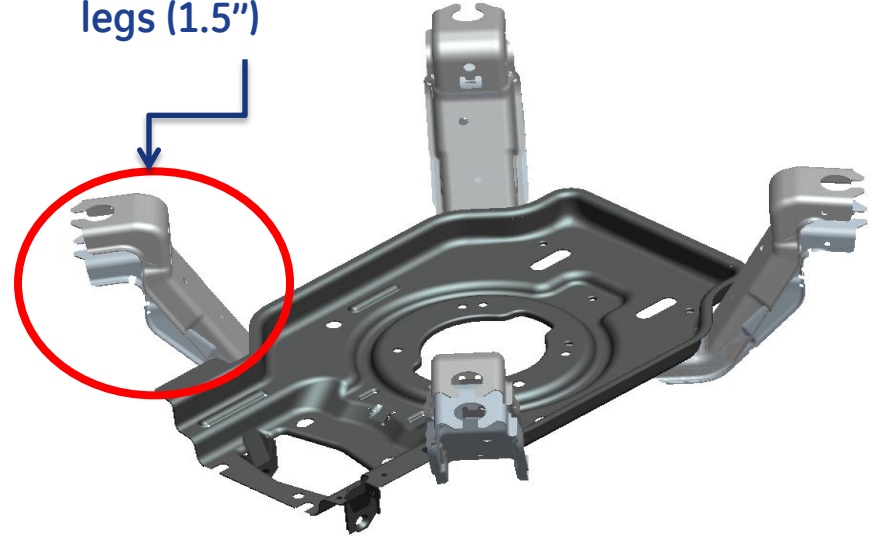

To remove the motor, disconnect harness, loosen and or remove the nuts from the mounting. Slide the motor forward and roll out toward the front.

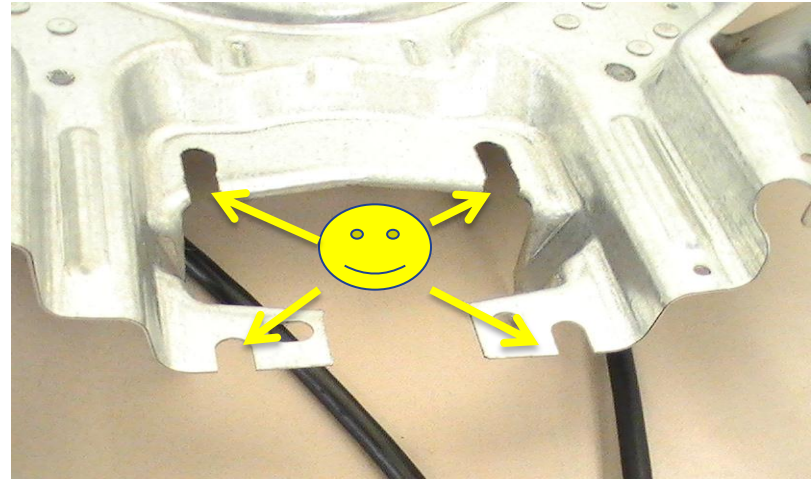

# Components Overview

## Pressure Sensor

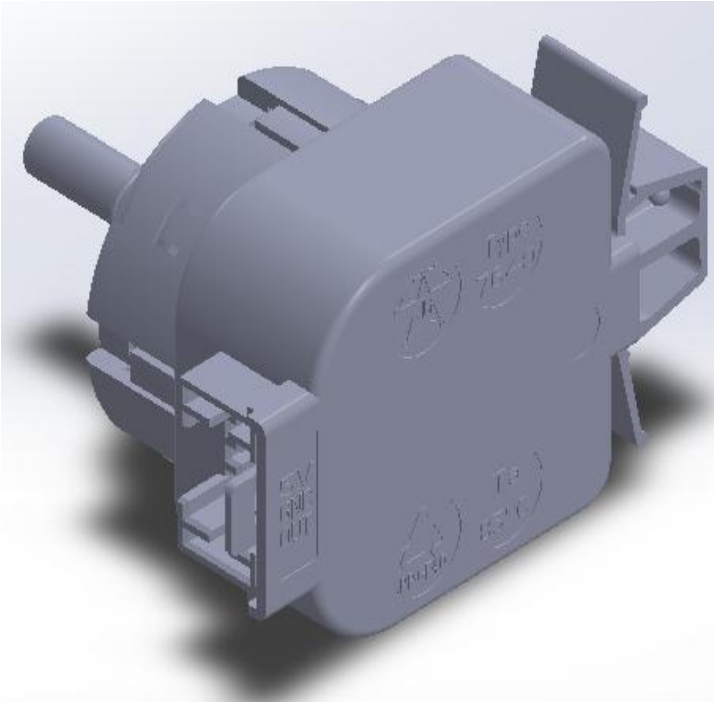

### Pressure Sensor

For models equipped with a pressure sensor the pressure sensor status will be determined by reading the pressure sensor's frequency.

If the pressure sensor's frequency is outside of the "Valid Values" then an error condition is set. The error condition will be logged in Service mode.

If Pressure Sensor Error occurs during cycle, the cycle will be canceled and the control should go to Idle.

If a cycle is started during a pressure sensor error, it will not fill and it will cancel the cycle.

# Components Overview

## Pressure Sensor

<b>Frequency VS. Water Level in inches</b>	
<b>Water level in inches</b>	<b>Frequency in Hz</b>
<b>2</b>	<b>1380</b>
<b>3</b>	<b>1374</b>
<b>4</b>	<b>1366</b>
<b>5</b>	<b>1358</b>
<b>6</b>	<b>1350</b>
<b>7</b>	<b>1342</b>
<b>8</b>	<b>1334</b>
<b>9</b>	<b>1325</b>
<b>10</b>	<b>1316</b>
<b>11</b>	<b>1307</b>
<b>12</b>	<b>1299</b>
<b>13</b>	<b>1292</b>
<b>14</b>	<b>1282</b>
<b>14.5</b>	<b>1278</b>
<b>15</b>	<b>1274</b>
<b>15.5</b>	<b>1270</b>

# Components Overview

## Pressure Sensor

There are 2 ways to test the Pressure Sensor.

1. Use a Hertz meter to read the Hertz at specified water levels.

For testing at the pressure sensor, the pin out is as follows:

- 1 = Ground
- 2 = Signal
- 3 = 5V

With that, you would want to test between pins 1, White Wire & 2, Red Wire to measure the signal.

2. Put the control into the service mode and turn the knob to the COLD water valve test. As the water level increases from Empty to Low Level, from low level to high level, and then to overflow level, three different indicator lights will come on above the Temp button. Service mode is entered by holding down the START button and turning the KNOB 180 degrees counting 8 clicks.

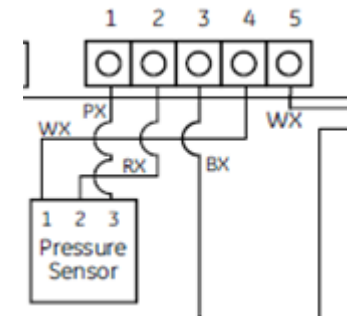
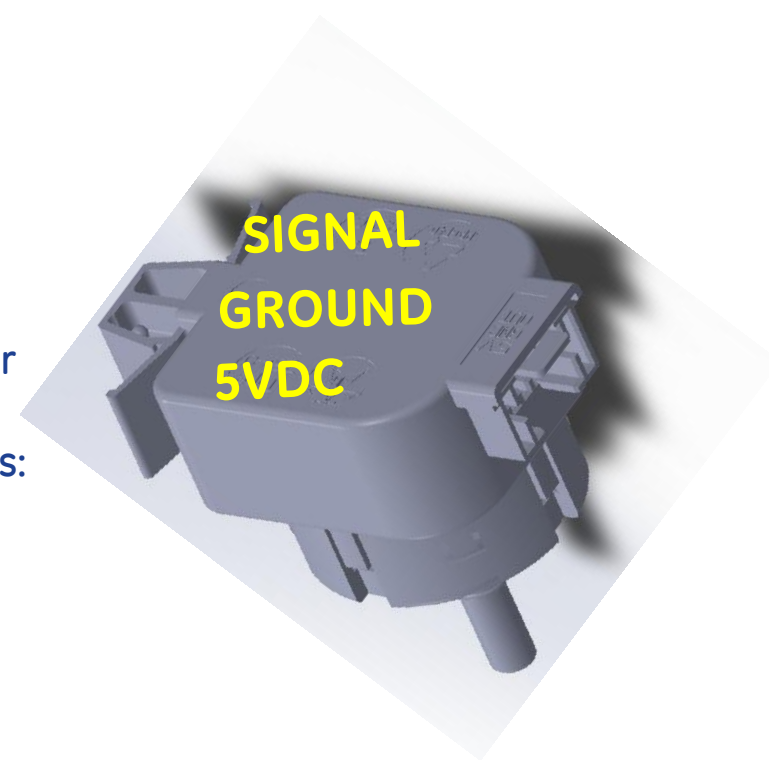

# Components Overview

## Pressure Sensor



When the low water level is sensed by pressure sensor, the cold water temp indicator light will illuminate.



Approximately between 3<sup>rd</sup> and 4<sup>th</sup> sidewall hole from the bottom.

# Components Overview

## Pressure Sensor



When the HIGH water level is sensed by pressure sensor, the COLD and COOL water temp indicator light will illuminate.



Approximately between 2<sup>nd</sup> and 3<sup>rd</sup> sidewall hole from the top.

# Components Overview

## Pressure Sensor



When the OVERFLOW water level is sensed by pressure sensor, the COLD, COOL, and colors water temp indicator light will illuminate.



Approximately between 1st and 2nd sidewall hole from the top. (When this level is reached, water fill will stop and drain pump will come on.)

# User Selected Load Size & Total Gallons Used

Gallons to Close Lower Pressure Switch	User Selected Load Size	Total Gallons for Load Size
	Agitator Model	
8.47	Small	10
9.90	Medium	12
	Medium Large	14
11.71	Large	16
	X Large	18
	XX Large	20
>11.71	Super	21
	Pulsator Model	
7.61	Small	10
9.04	Medium	11
	Medium Large	12
10.85	Large	13
	X Large	14
	XX Large	15
>10.85	Super	15.50



# Asymmetric Stroke Wash Profile

- Unequal CW and CCW impeller rotation
- Unequal Reverse direction is used to minimize out of balance.
- Unequal reverse rotation improves wash performance.

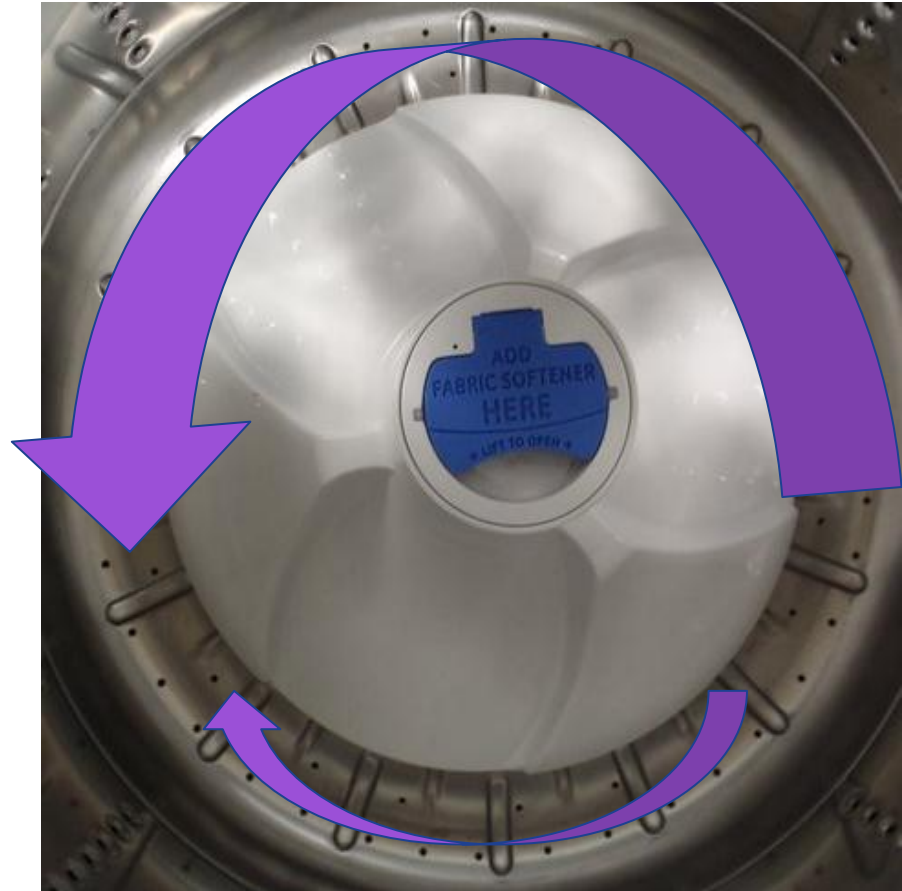

# Importance

- Turnover is a major driver of wash performance
- Turns clothes much quicker than equal stroke
  - Turns 5 flags in a 16lb load in approximately 4-6 minutes, compared to current production turnover time of approximately 12-14 minutes

# Diagnosing Hydrowave Washer Serial Communication faults

## Serial communication loss symptoms:

If communication is lost during First Fill, the Wash Basket will remain motionless. Approximately every 20 seconds the Control Board will flash the Fill Light and Beep twice. However, an OPEN Lid Switch can cause these same symptoms. LID flashing in the display is also an indication of communication lose. Determine which has occurred, either lost serial communication or a Lid Switch OPEN, by checking the Motor light. A 10-Flash error on the Motor indicates lost communication. If you see a steady ½ second-ON ½ second-OFF Motor light flash, this indicates a Lid Switch OPEN. A 7-Flash error on the Motor light indicates Lid Switch NOT OPEN.

If communication is lost during either the Main Wash or Spin cycles, the Mode Shifter will disengage and the Wash Basket will remain motionless. The Motor will display a 10-Flash error code indicating lost communication. If communication is restored, the cycle will continue.

If the Pressure Switch and or the pressure sensor does not close or gets to the proper reading within approximately 5 minutes during Drain, the Control Board will time out and shut down with NO lights illuminated. There will be NO error flash code on the Motor. However, the Control Board will display the Slow Pump error code in Service Mode.



# Diagnosing Hydrowave Washer Serial Communication faults

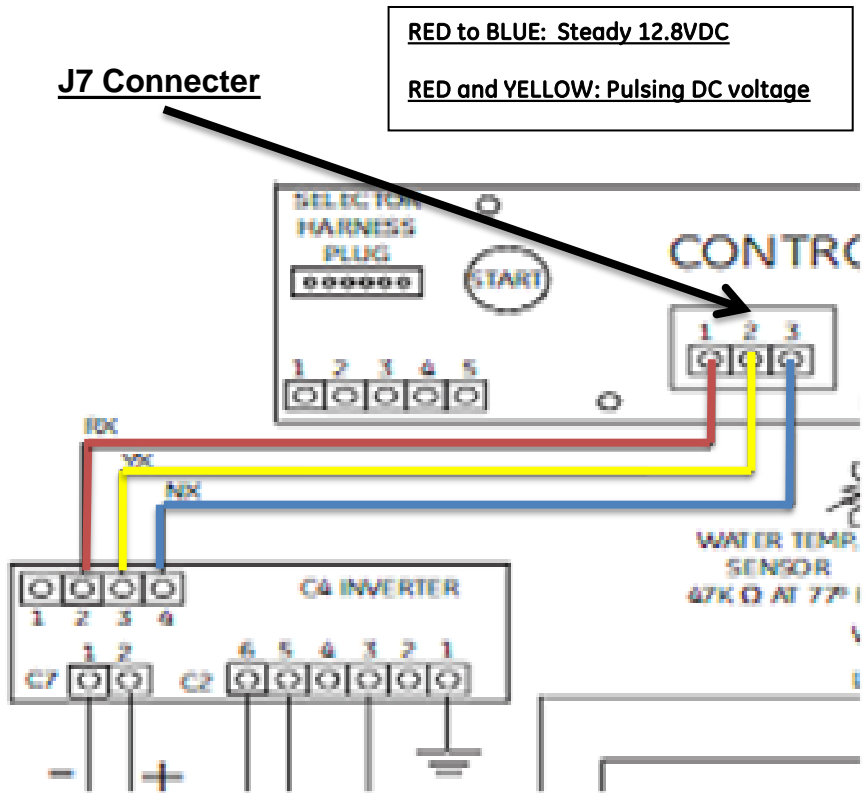

Communication voltages are sent from the Control Board to the Motor. Test for these steady and pulsing serial voltages at the Control Board **J7 Connector**.

Check for approximately **12.8 VDC** steady from **RED to BLUE**. The BLUE wire is DC ground. Check for the **pulsing DC** communication voltage from the **RED and YELLOW**. This is a pulsing, not a steady, voltage.

**If either voltage absent at the Control Board J7 Connector, replace the Control Board.**

If the steady and pulsing voltages are OK at the Control Board J7 Connector, disconnect the communication harness at the Motor and check the Motor harness connector for the same voltages found at the Control Board.

**If voltages are OK at the Motor harness connector, replace the Motor.**

# Field Service Mode

Press Start button while rotating Cycle Selection knob 180 degrees (8 positions) and then release the button.

The 7-segment display (SSD) will show t1 (Test No. 1). For units that do not have the 7-segment displays, status LED lights will be lit for the various test functions. See Test No. table below.

Rotate the knob clockwise to various positions (detents) per the table below to perform the functional tests.

Once the test number is selected, press the Start button to start the test.

In Test 4, press Start button to see the error code (see Error Code table). Press Start button again to delete the error code and to see if additional errors are recorded.

Termination of service mode can be accomplished by removing power to the washer (press Power button or disconnect power cord) or by waiting 30 minutes.



# Field Service Mode

Test No.	SSD	Soak LED	Wash LED	Rinse LED	Spin LED	Test Function
1	t1				On	LED & Lid Check
2	t2			On		Model Number
3	t3			On	On	EEPROM Version
4	t4		On			Error Codes
5	t5		On		On	Hot Water Valve Check
6	t6		On	On		Software Version
7	t7		On	On	On	Cold Water Valve Check
8	t8	On				Low Agitation Check
9	t9	On			On	High Speed Agitation Check
10	tA	On		On		Drain Pump Check
11	tb	On		On	On	Spin Check
12	tC	On	On			Model Configuration
13	td	On	On		On	Clearing EEPROM

# Field Service Mode

## Test 2 Model ID Number

The model ID number will be displayed on the SSD and on the Soil LEDs as a binary number. Use the Error Code table to translate the model number.

## Test 7 Cold Water Valve Check

The pressure sensor is also tested. The cold water will be turned on when the test is started.

When the water level reaches the lower pressure sensor level, the Cold Temp LED will light.

When the water level reaches the upper pressure sensor level, the Cool Temp LED will light.

When the water level reaches overflow pressure sensor level, the Colors Temp LED will light, the water will be shut off, and the drain pump will turn on. The 7-segment display will show a "C".



# Update Test 7 Cold Water Valve Check

## OLD Test 7 Wording

### Test 7 Cold Water Valve Check

The pressure sensor is also tested. The cold water will be turned on when the test is started.

When the water level reaches the lower pressure sensor level, the Cold Temp LED will light.

When the water level reaches the upper pressure sensor level, the Cool Temp LED will light.

When the water level reaches overflow pressure sensor level, the Colors Temp LED will light, the water will be shut off, and the drain pump will turn on. The 7-segment display will show a "C".

## New Test 7 Wording

The cold water will be turned on when the test is started. The 7-segment display will show a "C". The pressure sensor is also tested. When the water level reaches the lower pressure sensor level, the Cold Temp LED will light. The water will be shut off at the max fill level.



# Field Service Mode

## Test 12 Model Configuration

Test begins by pressing the Start button and all LEDs will blink.

To change the model number press and hold Spin and Temperature buttons for 3 seconds.

Use Soil button to increment the model number. Use Temp button to decrement the model number.

SSD will display the updated model number. The Soil LEDs will show the model ID number in binary form, as shown in the Error Code table. Press and hold Start button to save this data. Two validation beeps will sound and this mode will be exited.

## Test 13 Clearing EEPROM

Note: Starting this test will delete the consumer's My Cycle.

Pressing start button will restore the default EEPROM values. "EP" will be displayed on the seven-segment display. After a validation beep, the control will reset to Normal Wash Mode.

# Field Service Mode Duel Function LED Pattern

Depending on if you are in TEST 4 for Error Codes or if you are in TEST C for Model ID the same LED light s will light.

Example: Test C Model ID# 4 will light the soil LED light.

Test 4 for error code overflow will also light the Soil LED light.

Test No.	SSD	Soak LED	Wash LED	Rinse LED	Spin LED	Test Function
1	t1				On	LED & Lid Check
2	t2			On		Model Number
3	t3			On	On	EEPROM Version
4	t4		On			Error Codes
5	t5		On		On	Hot Water Valve Check
6	t6		On	On		Software Version
7	t7		On	On	On	Cold Water Valve Check
8	t8	On				Low Agitation Check
9	t9	On			On	High Speed Agitation Check
10	tA	On		On		Drain Pump Check
11	tb	On		On	On	Spin Check
12	tC	On	On			Model Configuration
13	td	On	On		On	Clearing EEPROM

Error Codes	None	Thermistor	Drain Pump	Stuck Button	Overflow	No Fill	Pressure Sensor
SSD	E0	E1	E2	E3	E4	E5	E6

LED Pattern	Soil LED Heavy								On	On	On	On	On
	Soil LED Normal					On	On	On	On				On
	Soil LED Light				On	On		On	On		On	On	
	Soil LED Ex Light		On		On		On		On		On	On	
	Model ID #		1	2	3	4	5	6	7	8	9	10	11



# Procedure for Programming WH12X10542 Control

When replacing the control, the washer will not function until the replacement control has been programmed.

1. After installing the new control, reconnect power to the washer to power up the control.
2. The new control will now display:
  - Models with a 2-digit display: " - - "
  - Models with only LEDs:

Soil LEDs			
Extra Light	Light	Normal	Heavy
ON	ON	ON	ON

# Procedure for Programming WH12X10542 Control

3. Set the appropriate Model ID # per the table below.

Press "Soil" button to increment Model ID #.

Press "Temp" button to decrement.

- Model ID # will show on the 2-digit display.
- For model having only LEDs, the Soil LEDs will indicate the Model ID # per the table below.

Washer Model Number	Model ID #	Display Type	Display
GTAN5250 GLWN5250	1	LED Model	Soil → Extra Light LED: ON
GHWN5250	2	Two Digit Display	2
GMAN5650 GTWN5450 GTWN5650	3	Two Digit Display	3
GTWN5350	4	LED Model	Soil → Normal LED: ON
GTWN5250	5	LED Model	Soil → Extra Light: ON Soil → Normal: ON
GLWN5550 GRWN5550 GTWN5950	6	Two Digit Display	6
GTAN5550 GTWN5550 GTWN5750 GTWN5850	7	Two Digit Display	7

4. Press and hold the Start button until two validation beeps are heard (around 3 seconds).

5. Press the Power button to reset the control.

6. The washer is now ready for use.

# Procedure for Programming WH12X10542 Control

If an error is made in programming the control, enter Field Service Mode as shown by the instruction on the backside or in the mini manual. Use Test 2 to view the model ID # and Test 12 to change the model ID number.

# ATC Temperature vs. Resistance Ohms

Temp C	Temp F	Resistance Ohms
5.0	41.0	125970
10.0	50.0	99045
15.0	59.0	78380
20.0	68.0	62415
25.0	77.0	50000
30.0	86.0	40289
35.0	95.0	32647
40.0	104.0	26598
45.0	113.0	21784
50.0	122.0	17932
55.0	131.0	14834
60.0	140.0	12329
65.0	149.0	10295

# Schematic Mini Manual

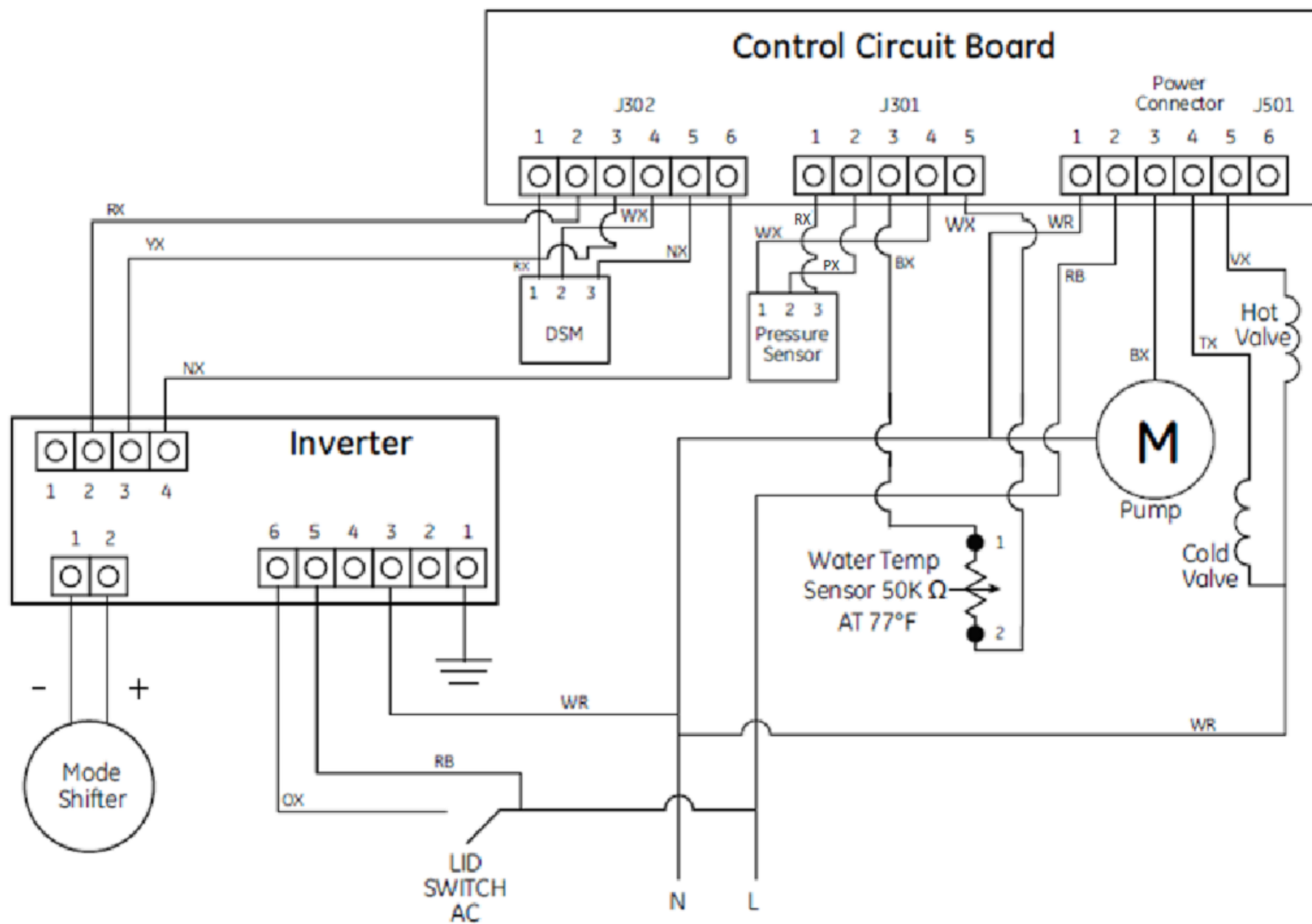

# Frequently Asked Questions

## FAQ

---

**Q:** What is the difference between Heavy and Light settings?

**A:** For Whites and Colors, the wash agitation time is increased by 6 minutes and for Permanent Press, by 12 minutes. (Times are approximate)

**Q:** What is the difference between Regular and Pulsed?

**A:** Regular means the washer will continuously agitate during the wash cycle. Pulsed provides a more gentle wash cycle by including pause periods during the wash cycle.

**Q:** Which cycle is best for heavily soiled items?

**A:** Whites or Colors cycles have the greatest wash intensity. This cycle provides the best overall cleaning . Permanent Press should be used for wrinkle-free and permanent press items.

**Q:** How can I reduce linting?

**A:** Sort wash loads by fabric type and whether they collect lint (velveteen, corduroy) or produce lint (terry cloth, chenille). Wash small loads for a shorter amount of time.

**Q:** How much detergent do I use?

**A:** For best performance, always follow the detergent manufacturer's instructions on usage. Many detergents are concentrated, so consult the product label and follow the clearly marked lines on the detergent measuring cups. Excessive detergent can negatively impact the wash performance.

